

# REPORT DOCUMENTATION PAGE

Form Approved  
OMB No. 0704-0188

Public reporting burden for this collection of information is estimated to average 1 hour per response, including the time for reviewing instructions, searching existing data sources, gathering and maintaining the data needed, and completing and reviewing the collection of information. Send comments regarding this burden estimate or any other aspect of this collection of information, including suggestions for reducing this burden, to Washington Headquarters Services, Directorate for Information Operations and Reports, 1215 Jefferson Davis Highway, Suite 1204, Arlington, VA 22202-4302, and to the Office of Management and Budget, Paperwork Reduction Project (0704-0188), Washington, DC 20503.

|   |  |                                  |   |   |                                  |
|---|--|----------------------------------|---|---|----------------------------------|
| 1. AGENCY USE ONLY (Leave blank)  |  | 2. REPORT DATE<br>15 November 00 | 3. REPORT TYPE AND DATES COVERED<br>Final, 16 May 00 – 15 November 00 |   |                                  |
| 4. TITLE AND SUBTITLE<br>A High Capacity Advanced Fuel Filtration System  |  |                                  | 5. FUNDING NUMBERS<br>N00167-00-C-0066                                |   |                                  |
| 6. AUTHORS<br>Chang-Wei Jen   |  |                                  |   |   |                                  |
| 7. PERFORMING ORGANIZATION NAME(S) AND ADDRESS(ES)<br>Mechanical Solutions, Inc.<br>1719 Route 10 E, Suite 205<br>Parsippany, NJ 07054  |  |                                  | 8. PERFORMING ORGANIZATION<br>REPORT NUMBER<br>MSI TR-8002            |   |                                  |
| 9. SPONSORING/MONITORING AGENCY NAME(S) AND ADDRESS(ES)<br>NSWC, Carderock Division<br>9500 MacArthur Boulevard<br>West Bethesda, MD 20817-5700   |  |                                  | 10. SPONSORING/MONITORING AGENCY<br>REPORT NUMBER                     |   |                                  |
| 11. SUPPLEMENTARY NOTES   |  |                                  | 20001124 105  |   |                                  |
| 12a. DISTRIBUTION/AVAILABILITY STATEMENT<br>Approved for public release; distribution unlimited   |  |                                  | 12b. DISTRIBUTION CODE  |   |                                  |
| 13. ABSTRACT (Maximum 200 words)<br>Report developed under SBIR contract for Topic Number N00-039. This project demonstrated the feasibility of an innovative design that combines a water-selective, cross-flow filtration (CFF), and a high capacity spiral-wound membrane element design into an integrated and individually contained filter cartridge. The filtration unit is composed of the individually contained cartridges (module). The modular design makes the upgrade and down-grade of the system capacity very flexible. Several potential hydrophobic membranes were tested, and the most suitable ones for the application were identified. Parametric studies of various water and solids content levels in JP-8 were performed through a bench-scale model for the candidate filter media. The filtration effect of the candidate filter media on the FSII contained in JP-8 has also been investigated. The test results lay a good foundation for the development of a prototype in Phase II. |  |                                  |   |   |                                  |
| 14. SUBJECT TERMS<br>SBIR Report<br>Filtration<br>Spiral-Wound<br>Water-Selective   |  |                                  | 15. NUMBER OF PAGES<br>46   |   |                                  |
|   |  |                                  | 16. PRICE CODE  |   |                                  |
| 17. SECURITY CLASSIFICATION OF REPORT<br>Unclassified   |  |                                  | 18. SECURITY CLASSIFICATION OF THIS PAGE                              | 19. SECURITY CLASSIFICATION OF ABSTRACT<br>Unclassified | 20. LIMITATION OF ABSTRACT<br>UL |

NSN 7540-01-280-5500

Computer Generated

STANDARD FORM 298 (Rev 2-89)  
Prescribed by ANSI Std Z39-18  
298-102

## TABLE OF CONTENTS

|  | Page |
|--|------|
| LIST OF FIGURES  | 3    |
| LIST OF TABLES   | 3    |
| LIST OF TEST DATA  | 3    |
| LIST OF ABBREVIATIONS  | 4    |
| <b>SECTION I</b>   |      |
| I.1. INTRODUCTION  |      |
| I.1.1 Background   | 5    |
| I.1.2 Objectives   | 6    |
| I.2. SUMMARY   | 6    |
| I.3. CONCLUSIONS   | 6    |
| <b>SECTION II</b>  |      |
| II.1 OUTLINE OF MSI'S PROPOSED METHOD  | 7    |
| II.1.1 Mechanisms of Water-Selective Membrane  | 9    |
| II.1.2 Cross-Flow Filtration   | 11   |
| II.1.3 Spiral-Wound Membrane Element   | 12   |
| II.2. FILTER CARTRIDGE DESIGN  | 13   |
| II.2.1 Hydrophilic Membrane Selection  | 13   |
| II.2.2 Test of FSII Rejection in the Selected Membrane   | 15   |
| II.2.3 Fabrication of Spiral-Wound Cartridge   | 16   |
| II.2.4 Spiral-Wound Cartridge Hydraulic Performance Evaluation   | 17   |
| II.3 TEST LOOP DESIGN  | 18   |
| II.4 QUALIFICATION METHODS FOR TEST RESULTS  | 19   |
| II.5. RESULTS AND DISCUSSION   | 19   |
| II.5.1 Water Separation Performance Evaluation   | 19   |
| II.5.2 Water Separation in JP-8+100  | 20   |
| II.5.3 Investigation of FSII Concentration Level in Feed and Permeate<br>Under the Effect of Various Water Content in Feed | 21   |
| II.5.4 Overall Dimension and Weight Estimation   | 22   |
| APPENDIX A - Test Procedures for Anti-Icing Additive (FSII)  | 31   |
| APPENDIX B - Test Data and Charts  | 33   |
| APPENDIX C - Calculation of Filter Cartridge and System Weight of Proposed 4000 GPM<br>Fuel Filtration Unit                | 43   |

## **LIST OF FIGURES**

1. Dead-End Filtration with Cake Formation vs. Cross-Flow Cake-Free Filtration
  2. Proposed High Capacity Advanced Filtration System
  3. Measuring Surface Energy
  4. Liquid Drop on Solid Surface Showing the Contact Angle
  5. Fuel Oil Passing Through an Oil Wettable Hydrophobic Membrane
  6. Wettability Pressure for a Typical Hydrophobic Membrane
  7. Spiral-Wound Membrane Element/Cartridge
  8. Surface Filtration vs. Depth Filtration
  9. Setup for FSII Rejection Test
  10. Permeate Tube for Bench-Scale Filter Cartridge
  11. End Cap for Bench-Scale Spiral-Wound Cartridge
  12. Filter Cartridge and Housing for Bench-Scale Model
  13. Filter Cartridge and Permeate Tube for Bench-Scale Model
  14. Bench-Scale Test Loop
  15. P & ID of Bench-Scale Test Loop
  16. Feed vs. Permeate
  17. Arrangement of a 4000 GPM Unit
- 
- B-1 Effect of Tricot Thickness on Flux
  - B-2 Effect of Permeate Tube Opening Area on Flux
  - B-3 Effect of Water Concentration in Feed on Flux
  - B-4 Gore Membrane vs. Tetratex Membrane
  - B-5 Effect of Dust in Feed on Flux
  - B-6 Effect of Water Concentration in Feed on FSII Concentrations in Permeate

## **LIST OF TABLES**

1. Test of Various Hydrophobic Membranes
2. Test of FSII Rejection

## **LIST OF TEST DATA**

- B-1 Effect of Tricot Thickness on Flux (Single Tricot)
- B-2 Effect of Tricot Thickness on Flux (Double Tricot)
- B-3 Effect of Permeate Tube Opening Area on Flux (Double Tricot, 2X Opening Area)
- B-4 Water Separation Test (0.5% water)
- B-5 Water Separation Test (1% water)
- B-6 Water Separation Test (3% water)
- B-7 Water Separation Test (5% water)
- B-8 Tetratex Membrane Water Separation Test (5% water)
- B-9 Solid Separation Test (5% water)

## LIST OF ABBREVIATIONS

|                     |                                    |
|---------------------|------------------------------------|
| ASTM                | American Society of Test Methods   |
| CFF                 | Cross-Flow Filtration              |
| COTS                | Commercial-of-the-shelf            |
| CPVC                | Chlorinated Polyvinyl Chloride     |
| FSII                | Fuel System Icing Inhibitor        |
| Ft <sup>2</sup>     | Square Feet                        |
| Ft <sup>3</sup>     | Cubic Feet                         |
| GPM                 | Gallons per Minute                 |
| GPM/Ft <sup>2</sup> | Gallons per Minute per Square Feet |
| HAZMAT              | Hazardous Material                 |
| Lbs                 | Pounds                             |
| mg/liter            | Milligrams per Liter               |
| P&ID                | Process and Instrument Diagram     |
| PES                 | Polyethersulphone                  |
| PTFE                | Polytetrafluoroethylene            |
| PVDF                | Polyvinylidene Fluoride            |
| PPM                 | Part per Million                   |
| PPS                 | Polyphenylene sulfide              |
| psi                 | Pounds per Square Inch             |
| UV                  | Ultra Violet                       |
| µm                  | Micron                             |

## I.1 INTRODUCTION

### I.1.1 Background

In order to protect engines and ensure their performance, filtration for particle removal and water separation are essential in all fuel oil systems. The largest problem for all filtration has always been fouling. This not only generates hazardous material (HAZMAT), but also creates a maintenance problem. The problem gets even more challenging when there is very limited space for the filtration system. In Naval applications (unlike land-based units), over-sizing of the filtration system cannot serve as a satisfactory compensation for poor filtration effectiveness. The appropriate solution is to have an efficient filtration system.

The filtration in a conventional shipboard fuel oil system out of a service tank is usually done in a two-stage process [1], first by filter/coalescing elements followed by separator elements. The filter/coalescing element is a depth filter, in which contaminants are collected on its surface or trapped through its depth. In the meantime, water is coalesced through the drag force of the hydrophilic material that forms the depth, such as cotton packages or synthetic fibers in which micro-sized water droplets are coalesced by the highly hydrophilic fibers to form a bigger water globule. The water globule is then separated from the oil by the Teflon coated separator elements.

The depth filters are functional through dead-end pressure feed, in which the fuel oil is pushed through the oil filter by the system pumping pressure. They are usually very effective in function, but not necessarily efficient in terms of operation. The dead-end pressure feed design is prone to plugging due to cake formation as shown in Figure 1.

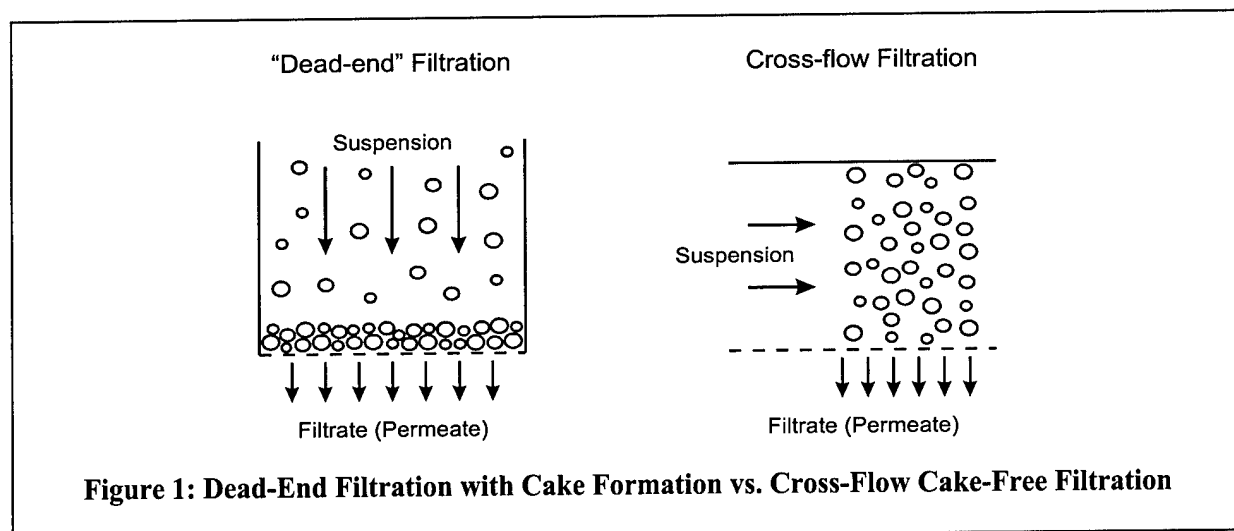

The other disadvantage of the depth filter element is its low surface-to-volume ratio (packing density), i.e. the membrane area of a cylindrical element is only its outside surface. For a high capacity application, the penalty for elements with low packing density is a heavy and bulky filtration unit. This is especially intolerable in a shipboard environment.

The modern oil filter design usually has cellulose media blended with synthetic media in the filter to trap dirt throughout its depth. This design improves the efficiency of the filter significantly. However, problems usually arise when filters are allowed to dry. In such a situation, particles are usually cemented inside the flow passage, which greatly reduces the flux rate during subsequent operation. Most of the time, the solution is to replace the oil filters whenever they are dry even if they are relatively new.

Besides the disadvantages mentioned above, maintenance is also a problem for the current shipboard fuel filtration units. Each filter vessel houses many coalescing and separator elements. To replace all the elements inside the filter vessels is a cumbersome and hazardous job. Workers need to wear body-protection gear to prevent attack from the volatile fuel oil fumes.

One other issue relevant to the Navy's need is to increase the sortie rate in the new CVNX class of aircraft carriers. A key fact to achieving this faster operation rate is to fuel aircraft at a faster rate, which can be done by increasing the fuel filtration capacity. Therefore the Navy needs a fuel filtration unit that can double the current capacity to 4000 GPM, can reduce the size and weight by half, and is maintainable at no risk to the health of technicians.

### **I.1.2 Objectives**

The goal of Phase I of this project was to demonstrate the feasibility of an innovative fuel filter design that combines a water-selective membrane, cross-flow filtration, and a high capacity spiral-wound membrane element design into an integrated and totally contained filter cartridge. The primary objective set for Phase I was to construct and evaluate a workable bench-scale model to demonstrate the feasibility of this design. The secondary objective was to lay the foundation for the development of a prototype in Phase II.

### **I.2 SUMMARY**

The concept of using a water-selective membrane for fuel and water separation in combination with the spiral-wound filter cartridge design in fuel filtration was proven to be feasible through tests using a bench-scale model. A Teflon (PTFE) membrane with a 0.1  $\mu\text{m}$  pore size was chosen as the best candidate to be used in the Phase II full size prototype development. A conservative flux rate of 0.75 GPM/ft<sup>2</sup> is set as the design criteria for the prototype development in Phase II based on the bench-scale test of the 0.1  $\mu\text{m}$  PTFE membrane. Based on the design criteria, it is achievable to design a fuel filtration unit with a capacity of 4000 GPM, which has double capacity of the current design, at a weight and volume that is half that of the current system aboard aircraft carriers.

### **I.3 CONCLUSIONS**

From all the tests performed, the following conclusions can be reached based on the test results:

1. The concept of using a water-selective membrane for fuel and water separation in combination with the spiral-wound filter cartridge design in fuel filtration was proven to be feasible.

2. A flux rate of 0.5 - 1 GPM/Ft<sup>2</sup> can be achieved and can be used as a design criterion in the Phase II full size filtration unit design.
3. A 4000 GPM system can be designed with twenty 8" x 40" spiral-wound cartridges.
4. The development of a 4000 GPM system which will have a weight and volume that is half that of the current 2000 GPM system is achievable.
5. PTFE membranes with 0.1 µm pore size rating are the best choice for the application of water and fuel oil separation and should be used in the Phase II full size prototype design.
6. The fuel quality will surpass the requirement of 5 PPM for water based on ASTM D 3240 and 2 mg/liter for sediment based on ASTM D 5452.
7. The fuel flux rate will decrease with the increase of water content in the fuel. This is especially obvious when water content is below 1%.
8. The fuel flux rate will decrease with the increase of solids content in the fuel. If the solids level is high in the application (above 100 PPM), a prefilter is recommended in the system.
9. The FSII in the fuel will not be depleted by filtering through the 0.1 µm PTFE membranes when there is no water in the fuel.
10. The FSII is soluble in the water and will be separated with the water by the 0.1 µm PTFE membranes when water is present, only the undissolved FSII will pass through the membrane. The content of FSII may need to be replenished to meet the required range of 0.15% to 0.20% v/v after going through the filtration unit.
11. The Phase I project met all of its goals and expectations. The design concept has been proven to be feasible and effective. Funding for a vigorous Phase II project appears to be justified.

Some of the conclusions made above are based on the test results of the application of 0.1 µm PTFE membranes in the JP-8 fuel with 5% water content and 100 mg/liter equal mixture of ISO 12103 fine and coarse grade test dust. It is very unlikely that the JP-5 fuel from the service tanks, which has been processed through centrifugal purifiers, will have a fuel quality worse than this tested fuel quality. Therefore, the above conclusions should be reasonable if not conservative.

## **II.1 OUTLINE OF MSI'S PROPOSED METHOD**

MSI has conceived of a novel approach, which will provide a water-selective filter element that will simplify the current two-stage filtration and separation process into a single process. It will be a cross-flow, surface filtration technique, which will minimize the build up of a surface cake layer, and eliminate the passage blockage of depth filtering encountered in the dry condition. In addition, the filter element takes advantage of a spiral-wound membrane cartridge design, which

will maximize filtrate flow capacity in a given volume to facilitate high capacity applications. The proposed design is a systematic modular design, in which each module is a totally contained element cartridge with its own housing. The cartridge replacement will be simple and easy, and there will be no concern for direct human contact with fuel oil fumes. The modular design also makes the system very flexible to either upgrade or down-grade in capacity. Figure 2 shows the layout of MSI's proposed high capacity advanced filtration system.

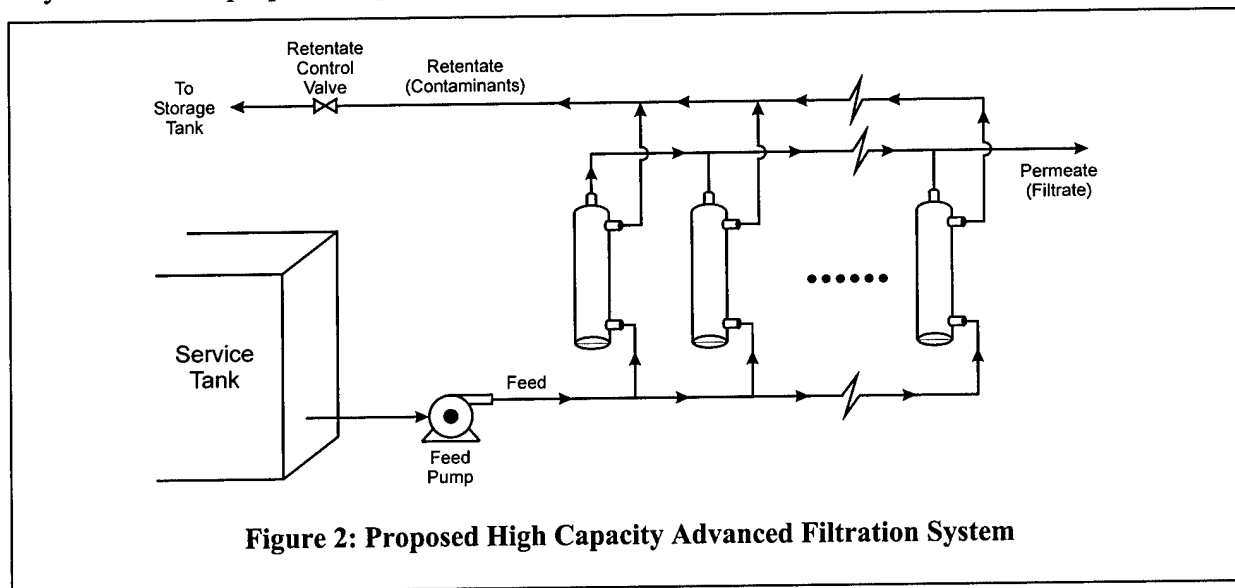

**Figure 2: Proposed High Capacity Advanced Filtration System**

An explanation of MSI's innovative design concept is shown below.

- 1) Fuel oil from the service tank is fed to the feed manifold by the feed pump; the flow enters the filter cartridge at one end.
- 2) The fluid channel in spiral-wound membrane elements is formed by spacers. A spacer has a given thickness and mesh-pattern, which will promote turbulence on the membrane surface to enhance cleaning of the surface filtration membrane.
- 3) A cross-flow is formed by the axial flow, which sweeps the membrane surface with high shear motion and simultaneously is pressured against the oil-wetted and hydrophobic membrane surface.
- 4) Oil (also called permeate or filtrate) will penetrate into the membrane pores, driven by the applied fuel pump pressure, leaving water droplets and debris trapped outside the membrane to be removed by the shear force.
- 5) The permeate being driven by the trans-membrane pressure will travel to the permeate tube which also serves as the core of the spiral-wound membrane element.
- 6) All the collected permeate is piped to the permeate manifold, and then supplied to the fueling stations on the flight and hangar decks.
- 7) The separated debris and water droplets (also called retentate or concentrate) are piped to the retentate manifold, and then connected to a waste tank or cycled back to the service tank depending on the processing design.
- 8) The membrane elements are designed as totally contained filter cartridges, and are connected to the feed, permeate, and retentate lines through three quick-disconnect connections. Therefore, replacing a cartridge will be a simple job, and no tools are needed.

## II.1.1 Mechanisms of Water-Selective Membrane

The function of water-selectivity can be accomplished by taking advantage of the different susceptibility to surface wetting (wettability) in different materials. "Wetting" is a term from surface science. It involves consideration of the forces of inter-molecular behavior of phase boundaries and interfaces, which is a substantial subject area. The discussion below will only touch the relevant basic concepts concerning liquid droplets and substrate surfaces.

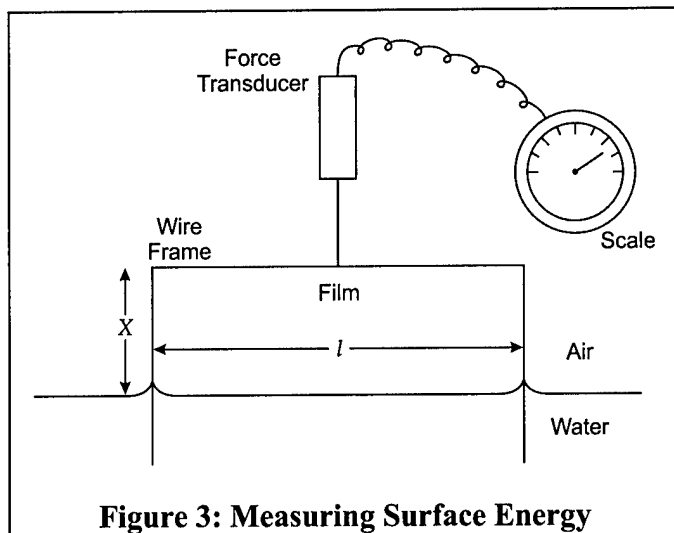

**Figure 3: Measuring Surface Energy**

a distance  $dx/2$  through the interface. In such an instance, an amount of work  $w$  is done, given by (remembering that interfaces form on each side of the film)  $w = f \cdot l \cdot dx$ . This may also be written in terms of the area ( $A$ ) of film  $w = f \cdot dA$ , in which  $f$  has a unit of energy per unit area, and  $w$  is the maximum useful work done by the interface, known as the surface free energy. The term  $f$  can be equally thought of as a surface tension with units of N/m or a surface free energy (sometimes simply called surface energy) with units of  $J/m^2$ . The two quantities are identical, i.e. a measurement of surface tension is equivalent to a measurement of surface energy. The level of surface tension depends on the strength of intermolecular forces. To give an idea, the typical surface tension of water is  $72.5 \cdot 10^{-3}$  N/m, and of hydrocarbon fluids such as n-octane is  $21.6 \cdot 10^{-3}$  N/m, n-decane is  $23 \cdot 10^{-3}$  N/m.

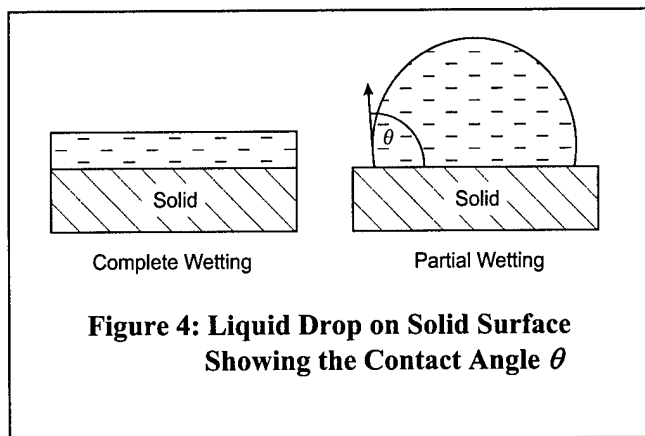
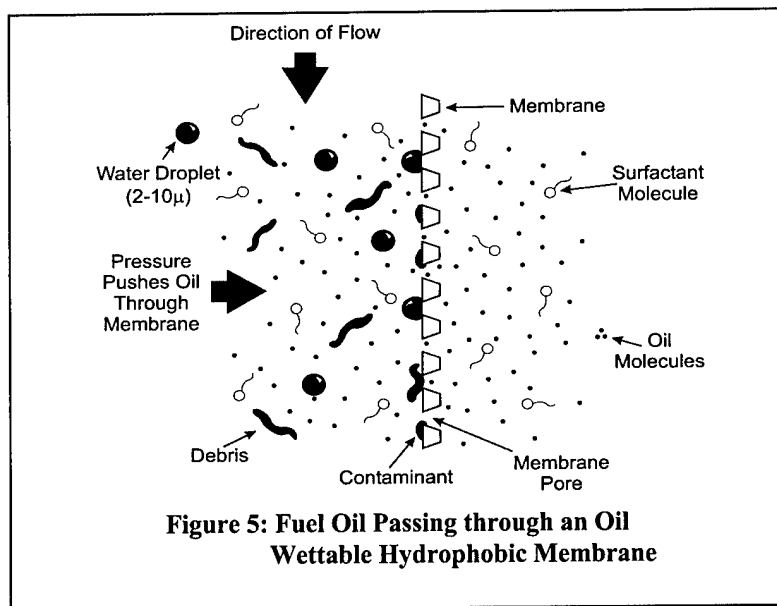

**Figure 4: Liquid Drop on Solid Surface Showing the Contact Angle  $\theta$**

To quantify the wettability between liquid droplets and substrate surfaces, two measurements are commonly used, i.e. surface tension (interfacial tension) and contact angles [2,3]. The concept of surface tension is depicted in Figure 3. When a rectangular wire frame of width  $l$  is pulled a distance  $X$  through a liquid interface (e.g. air/water interface), a thin film of liquid may be formed. If the frame is attached to a sensitive spring balance or force transducer, a force or tension is detected acting along the width of the frame. Suppose that the force is  $f$  per unit length, when the frame is pulled

When a drop of liquid is placed on a solid, the liquid either spreads to form a thin, more or less uniform film or remains as a discrete drop as shown in Figure 4. The former behavior is generally described as complete wetting, and the latter as incomplete or partial wetting. The external measure of the degree of wetting is the contact angle,  $\theta$ , i.e. the angle formed between planes tangent to the surfaces of the solid and the liquid at the wetted perimeter. A zero contact angle ( $\theta = 0$ ) is

the condition for complete wetting of a solid by a liquid (e.g. water on clean glass). Conversely, complete non-wetting dictates an angle of  $180^\circ$ , and this is only possible for a liquid in a liquid. Typical values cited from Table 1 of [3] are, a contact angle between water and Teflon (PTFE) is  $112^\circ$ , while between n-octane and PTFE the contact angle is  $30^\circ$ , and between n-decane and PTFE it is  $40^\circ$ . If the contact angle is greater than  $90^\circ$ , the liquid drop moves easily about the surface and, in such a case, will not enter a sufficiently small diameter capillary made of the solid such as a membrane pore. The surface of such a solid is called hydrophobic.



The concept of MSI's water-selective filter is to use a hydrophobic membrane for water separation. Most hydrophobic membranes are wettable by fuel oil, such as Teflon membranes. This can be realized by reviewing the contact angles between PTFE and the liquids described in the last paragraph. As shown in Figure 5, in MSI's proposed system an influx of fuel oil together with undissolved water is fed through a hydrophobic membrane. Since the membrane is oil-wettable, oil will pass into

the narrow pore, leaving water trapped on the membrane surface. Because of the capillary pressure (water wettability pressure) resistance, water will not pass through the membrane pore unless the trans-membrane (feed minus permeate) pressure can overcome the capillary pressure. Figure 6 shows the relation between water wettability pressure and membrane pore size based on

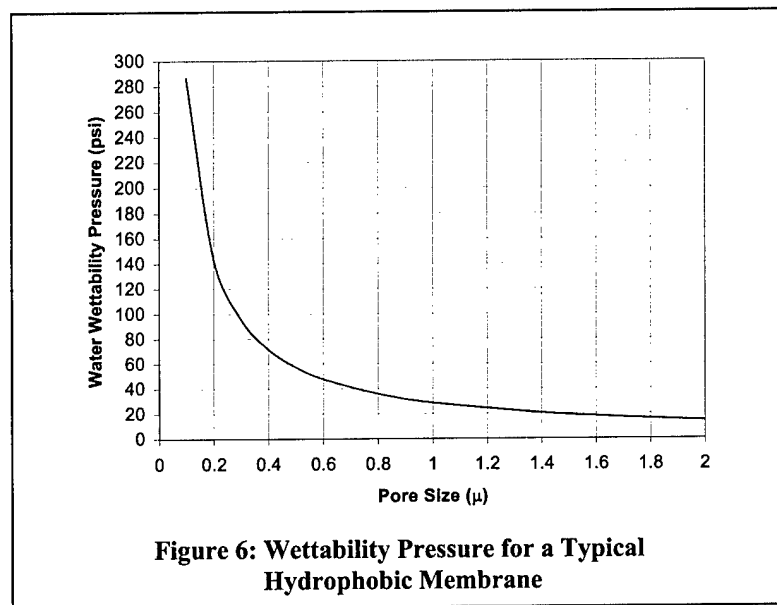

water mixed with Alkanes (C14-C18) using a PTFE membrane. From Figure 6, a membrane pore size can be determined for a given oil/water separation application. For instance, a membrane pore size of  $1 \mu\text{m}$  would be a good choice for a trans-membrane pressure of 30 psi or less. The typical size of an undissolved water droplet in fuel oil is 2-10  $\mu\text{m}$  (free or emulsified), and therefore using a  $1 \mu\text{m}$  membrane would guarantee separation of the water mixed in the oil.

## II.1.2 Cross-Flow Filtration (CFF)

The feed flow in this design is driven within the filter in an axial direction relative to the filter surface as shown in Figure 7A. Since the flow is in parallel with the filter surface and at the same time is being pressurized against the filter surface, it forms CFF. There are three main factors which rule the performance of a CFF filter. They are: 1) pore size; 2) the generated shear force at the surface of the medium; and 3) the deposit layer (secondary membrane) and the control of its formation.

Contrary to intuition, the operational capacity and life of fine-porous filter media is often higher than the capacity of otherwise permeable, more open media. This is because large pores facilitate penetration of small particles inside the pores, and therefore large pores promote internal clogging, since small particles enter the pore and become trapped inside. This fact explains the paradoxical behavior of media during CFF. More open media usually yield - after a certain initial time - a lower filtrate flux because of a higher degree of internal clogging. Per the report of Murkes and Carlsson [4], media with a pore size of 0.1-2  $\mu\text{m}$  give a higher filtrate capacity than media with pore sizes on the order of 10  $\mu\text{m}$  and higher. In addition to this (and this case is consistent with intuition), pores which are too large cannot retain the very small particles and the filtrate may then not be as particle-free. These are the reasons that the pore size of the proposed filter will be rated at no greater than 2  $\mu\text{m}$ .

Flow velocity is of fundamental importance to the performance of a cross-flow filter. Should the flow velocity become zero, the cross-flow stops and the dead-end filtration (with its various drawbacks) starts. The cake layer, which forms on the filter media at zero velocity, becomes thinner when the flow velocity parallel to the medium increases. The thickness of the cake layer in a flow channel is determined by the shear force on the membrane surface which is roughly in direct proportion to the feed viscosity and the feed flow velocity. Therefore, higher velocity entails a thinner deposit layer, a lower permeate resistance, and therefore a higher filtrate flux.

In almost every filtration process, a "secondary membrane" often called a "dynamic membrane" will be created. The remaining question then is how to control and optimize the "system" which includes this layer. The contaminants, which constitute the secondary membrane, first fill up the pores and then form a very thin cake of constant thickness. The period of pore filling (the transition time) may be very short. In fact, based on evidence from micrographs, immediately upon the filter's first use the particles begin to enter the pores to a limited extent (although the pores are usually not totally entered). This is why a typical CFF system usually goes through a rapid flux drop at the beginning of its use for filtration. Following this, the flux is stabilized at a relatively satisfactory level, and remains almost constant with a very slow decline as the process continues. This is unlike dead-end filtration, in which the flux rate drops rapidly from very beginning until the filter is completely plugged. The rate of flux drop depends on the selection of membrane pore size and the contents of any contaminants, and therefore it is important to choose the right pore size as a function of the type of contaminants in the particular service, in order to control the formation of the deposit layer. Also, unlike dead-end filtration, the surface dynamics of CFF does not force any gelatinous contaminants to extrude through the filter membrane's pores, which (when it occurs) often compromises the filtration performance.

### II.1.3 Spiral-Wound Membrane Element

Spiral-wound membrane elements are the most efficient design as far as the surface-to-volume ratio is concerned (Figure 7A). The design allows for optimum membrane surface area to produce good permeate flow for the size of equipment required. By taking advantage of the standard polymeric piping size available on the market, it is common for the spiral-wound membranes to be housed in polymeric pipes and made as totally contained disposable cartridges. This disposable design has also been well accepted by the industry.

For a typical membrane cartridge of 4" (Schedule 40 pipe) in diameter, with a nominal length of 40" (4" x 40"), the membrane area is about 50 ft<sup>2</sup>. The membrane area for a 6" x 40" membrane cartridge is about 120 ft<sup>2</sup>, and for a 8" x 40" membrane cartridge is about 280 ft<sup>2</sup>. Note that for a 40" length cartridge, the membrane length is about 3 ft, with the end caps serving as the inlet and outlet chambers, giving a nominal overall length of roughly 40" as shown in Figure 7B.

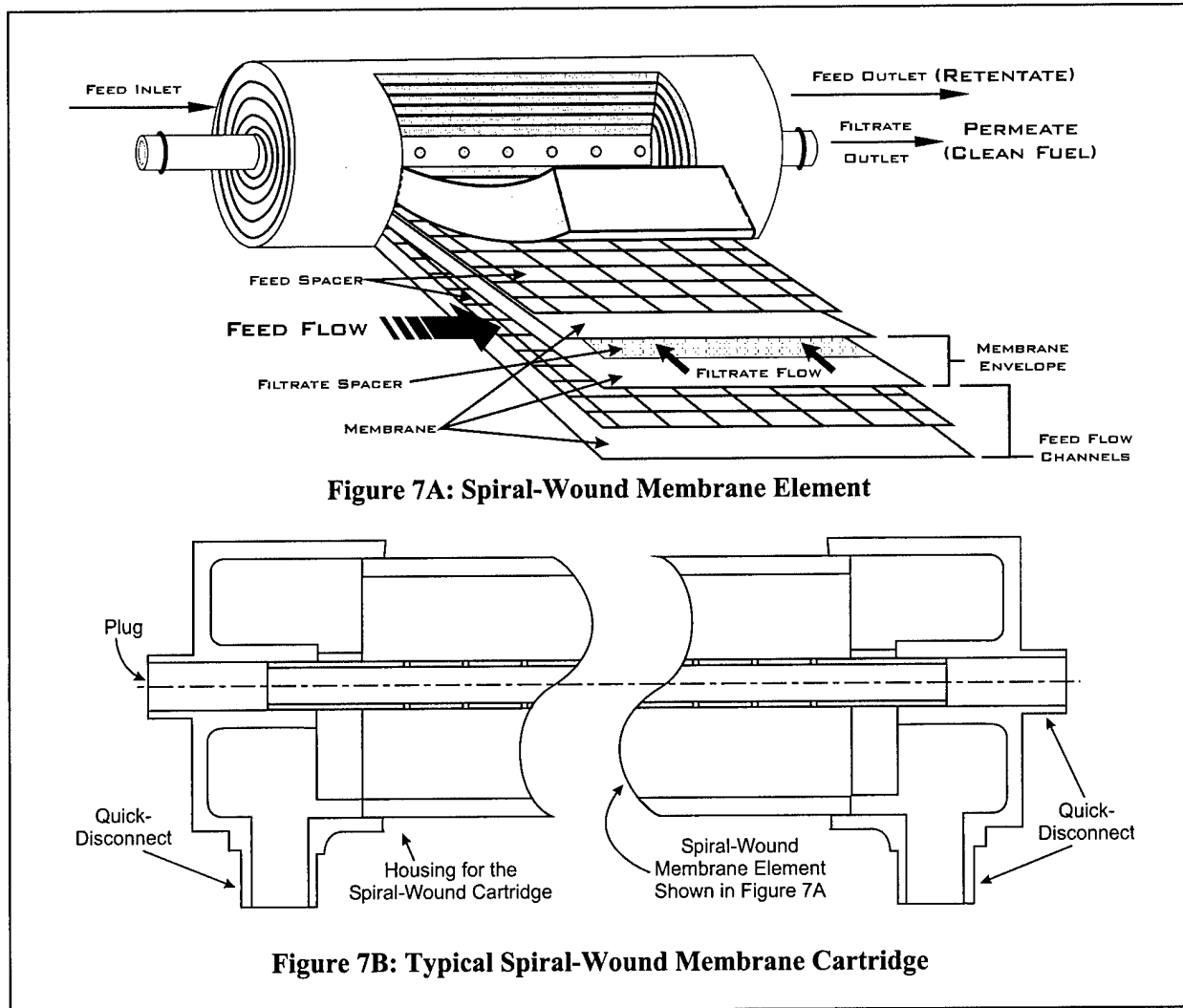

The most commonly available standard polymeric piping materials are PVC (Polyvinyl chloride), CPVC (Chlorinated polyvinyl chloride) and polypropylene. The PVC material is

compatible with kerosene, and therefore it is very likely that it is compatible with JP-5, which is a kerosene-type jet fuel.

Besides having a high surface-to-volume ratio, the other major advantage of the spiral-wound design is the enhanced cleaning due to turbulent flow at the membrane surface, and surface filtration. The turbulent flow is promoted by the mesh spacers between the layers of membrane envelopes as shown in Figure 7A. This feature combined with cross-flow dramatically reduces fouling, enhancing machine performance and membrane life.

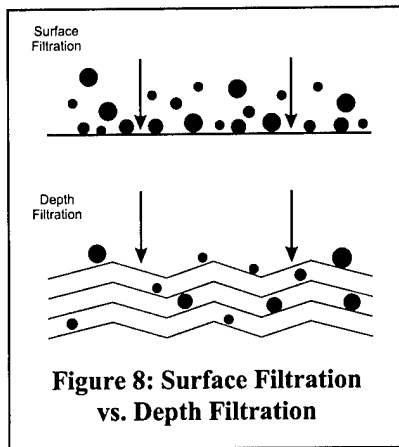

The filtration performed by the spiral-wound polymeric membrane is surface filtration (Figure 8) as opposed to depth filtration, which is currently used in the two-stage fuel oil filtration system. In a depth cartridge filter, the feed flows through the thick wall of the filter where the particles are trapped throughout the complex openings in the media. The filter may be constructed of cotton, cellulose, synthetic yarns, or “blown” micro-fibers such as polypropylene.

Depth filters are commonly used in dead-end filtration design, because the function of their thick walls serves for both particle separation and dirt-holding. This design not only greatly degrades the filtration efficiency over time, but also creates problems when left dry. Under dry conditions, the particles left in the flow passages tend to cement to the filter material and blind the passages. Once this happens, the filters cannot be salvaged.

## II.2 FILTER CARTRIDGE DESIGN

### II.2.1 Hydrophobic Membrane Selection

Several hydrophobic membranes have been acquired from different manufacturers. A test was performed on these acquired membranes in order to pick the most suitable one for the application. The purpose of the test is to determine the degree of hydrophobicity of the membranes in a jet fuel-water-membrane surface system in terms of water breakthrough pressure, at which water starts to bleed through membrane pores. Naturally, the more hydrophobic the membrane surface is, the greater repellent force it has between the membrane surface and water drops, i.e., the higher the water breakthrough pressure will be. The goal is to find a membrane having a high water breakthrough pressure (greater than 50 psi) in the micro-pore size range (0.1 – 1  $\mu\text{m}$ ). All samples were tested following the same procedure shown as follows:

- 1) cut the membrane sample into a 45 mm diameter test coupon,
- 2) wet the coupon with JP-8 jet fuel,
- 3) place the coupon in the stirred cell,
- 4) add 150 ml of JP-8 and 3 ml (2%) of water to the cell

- 5) connect compressed air to the cell through an air regulator and increase the air pressure gradually to the desired pressure setting,
- 6) open the air valve to let the air push the fluid through the membrane until nothing more will pass through it,
- 7) collect the fluid (permeate) that has been pushed through the membrane using a clean glass beaker,
- 8) close the air valve,
- 9) observe the permeate to check if any water exists in the permeate.

Note that the filtration system under development is for the application of shipboard Aviation fuel, which is JP-5. Because JP-5 is not immediately available for testing, JP-8, which has very similar physical and chemical properties to JP-5, is used instead in this Phase I project.

The test results are listed in Table 1 in descending order if the water breakthrough pressure.

| No. | Type of membrane, Manufacturer  | Water Breakthrough Pressure |
|-----|---|-----------------------------|
| 1   | 0.1 $\mu\text{m}$ , PTFE with Polyphenylene Sulfide (PPS) backing, Gore | > 50 psi                    |
| 2   | 0.1 $\mu\text{m}$ , PTFE with Hela backing, Gore                        | > 50 psi                    |
| 3   | 0.1 $\mu\text{m}$ , PTFE with Polyester backing, Tetratex               | > 50 psi                    |
| 4   | 0.22 $\mu\text{m}$ , PTFE with Polyester backing, Tetratex              | 50 psi                      |
| 5   | 0.1-0.2 $\mu\text{m}$ , PVDF with polypropylene backing, Sepro          | 20 psi                      |
| 6   | 0.45 $\mu\text{m}$ , Acrylic Copolymer, Pall                            | 20 psi                      |
| 7   | 0.3 $\mu\text{m}$ , PVDF, Osmonics                                      | < 20 psi                    |
| 8   | 0.45 $\mu\text{m}$ , Polyethersulfone (PES), Pall                       | < 20 psi                    |

Table 1: Test of Various Hydrophobic Membranes

Note that all the tests done above are based on visual inspection except for the first test. In the first test, 250 ml of permeate (filtered jet fuel) was collected at 50 psi. The 250 ml permeate was then passed through the Aqua Glo test pads (ASTM D3240), and was confirmed to have a water content less than 1 PPM. This test also confirmed the visual inspection. Free water usually shows up as beads. Even a very tiny bead can be spotted in clean fuel if checked carefully.

The test results show that PTFE (Teflon) membranes from both Gore and Tetratex have the best hydrophobicity. PTFE, which has the lowest surface energy (18 dyne/cm) of all polymeric materials, not surprisingly showed the best hydrophobicity. PVDF, which has a typical surface energy of 25 dyne/cm, is an intrinsic hydrophobic material. It is usually considered the next best hydrophobic material after PTFE. However, the water breakthrough pressure of PVDF seems to be much lower than that of PTFE (shown in our test). This is probably because of the effect of the fuel oil. It is expected that the water breakthrough pressure would be high if PVDF was tested with water alone. However when PVDF is wetted with fuel oil, the hydrophobicity is

compromised. Therefore, the PVDF membrane may not be a good candidate for our application as a water-selective membrane for water and fuel oil separation.

The Acrylic Copolymer membrane shows better hydrophobicity than all other samples of comparable pore size except for PTFE membranes (note that PVDF membrane shows equal trans-membrane pressure, but the pore size is rated smaller). However, the membrane seems to swell in the water/oil mixture observed during the test. This membrane is probably only good for air filtration, and is not suited for the liquid environment.

A membrane with a water breakthrough pressure around 20 psi may be used in a carefully designed fuel oil filtration system. For more practical applications, it is desirable to have a water breakthrough pressure of at least 40 psi. In such a case, there will be a good range for the adjustment of the trans-membrane pressure for various operating conditions. It is common to have a trans-membrane pressure between 30 and 40 psi in a spiral-wound membrane cartridge application. Based on the test results, the 0.1  $\mu\text{m}$  PTFE membranes are the most suitable choice.

### II.2.2 Test of FSII Rejection in the Selected Membrane

The purposes of the tests are 1) to check the content of the FSII in the JP-8 that was acquired from NAWC, Lakehurst, 2) to evaluate the amount of rejection of FSII for mixed with JP-8 fuel passing through the 0.1  $\mu\text{m}$  PTFE (Teflon) membrane that was proposed to use in designed spiral-wound cartridges.

A B/2 anti-icing additive (FSII) test kit was used in the tests. Following the test procedures attached in Appendix A, the FSII content in the JP-8 from Lakehurst was identified to be 0.12% by volume based on the JP-5 reading of the refractometer in the test kit. Note that the same test has been repeated several times and the results were all consistent. The typical FSII level in JP-8 is around 0.15% v/v. and between 0.15 to 0.20% is acceptable.

The test setup for the second test purpose is shown as in Figure 9 and two separate tests were performed.

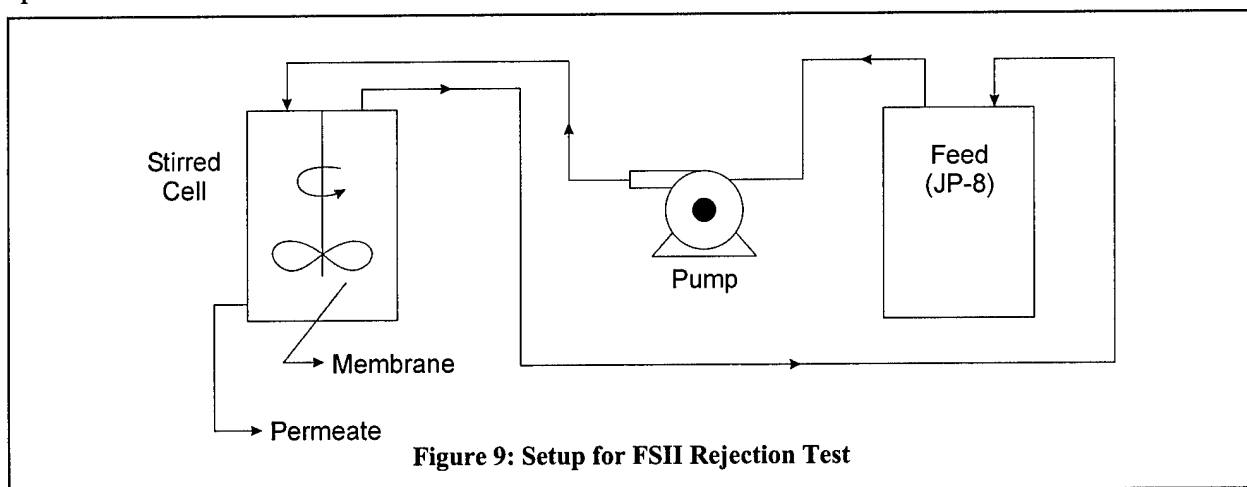

The test procedures for the tests are shown as follows:

- a) Cut the 0.1  $\mu\text{m}$  PTFE membrane of Gore to a coupon with a diameter of 65 mm. Place the coupon onto the membrane holder of the stirred cell used for the test

For Test 1:

- b) Add approximately 0.1 ml of FSII into a bottle, which contains 500 ml of JP-8 fuel (the FSII content is 0.12% v/v.).
- c) Shake the bottle rigorously for 5 minutes, then let the bottle sit for 2 minutes. Check the bottom of the bottle to make sure that there are no settled droplets (FSII).
- d) Filter 250 ml of the mixed JP-8 fuel through the 0.1  $\mu\text{m}$  PTFE membrane.
- e) Measure the FSII content of the feed and permeate using the same B/2 anti-icing additive test kit mentioned above.

For Test 2:

- f) Add approximately 0.4 ml of FSII into a bottle, which contains 500 ml of JP-8 fuel (the FSII content is 0.12% v/v.).
- g) Repeat Steps c) to e).

The test results are shown in Table 2. Both tests showed that a small percentage (approx. 5-6%) of the FSII was stripped off in the filtration process using the 0.1  $\mu\text{m}$  PTFE membrane. Based on this, depletion of the FSII in jet fuel during the filtration process through the 0.1  $\mu\text{m}$  PTFE membrane should not be a concern. In order not to complicate the test, the effect of water on FSII in JP-8 was not evaluated. Since FSII may be soluble to water, it may be retained (totally or partially depending on water level) with water when water is separated from jet fuel. The water effect was evaluated and shown in II.5.

|   | Test 1 | Test 2 |
|---|--------|--------|
| Feed                                    | 0.132% | 0.210% |
| Permeate                                | 0.125% | 0.197% |
| Difference between<br>Feed and Permeate | 5.30%  | 6.19%  |

Table 2: Test of FSII Rejection

### II.2.3 Fabrication of Spiral -Wound Cartridge

The parts need for the bench-scale membrane cartridge fabrication have been designed and fabricated. The drawings for the permeate tubes and end caps are shown in Figures 10 and 11. Miscellaneous parts used in the bench-scale cartridges such as spacers for the feed and permeate passages, shrink fit tube to hold the wounded membrane leaves, "O" rings, "U" cups and Epoxy are all COTS items. The housing material is PVC and is designed to be reusable.

Two spiral-wound cartridges were created using the Gore membranes with Hylar backing. The Hylar backing is chemically compatible with jet fuel. There is a slight difference in the construction of the permeate envelope between the two cartridges. The first one has a single layer of tricot, which is an epoxy coated polyester woven substrate commonly used to carry the

permeate flow to the permeate tube inside the permeate envelope. The second cartridge has double layers of tricot. The purpose is to compare the flux rate between the two different structures. Since the flux rate is expected to be high, the flow passage created by a single layer of tricot may cause high flow resistance to the permeate flow and thus affect the flux rate. On the other hand, cartridges using double layers of tricot to reduce permeate flow resistance will slightly reduce the membrane area and will also increase cost. The diameter of the two created test cartridges is 1.5". This yields a membrane area of roughly 4.5 ft<sup>2</sup>. The feed channels in the spiral wound cartridge are formed with a 0.045" thick Nylon screen layer from Naltex. The pattern configuration of this screen is a symmetrical diamond shape with eight strands per inch.

The epoxy adhesive used for making the cartridges is from 3M (Scotch-Weld, 2216 B/A), which is claimed to be compatible with jet fuel. Several epoxy samples were also received from other vendors. In order to select an optimum adhesive for this project, all epoxy samples are under various evaluation tests, such as a soaking test with jet fuel, viscosity test, peeling test, working time test, and curing schedule test.

Figure 12 shows the completed filter cartridge and its housing. The black surface is a PVC heat-shrink tube that wraps around the spiral-wound cartridge to keep it in shape. Figure 13 is a close up at one end to show the end cap, "U" cup seal, and "O" ring seals of the cartridge. The "U" cup seals against the cartridge housing to isolate the feed flow from the retentate flow, and the "O" ring isolates the feed flow from the permeate flow. Figure 13 also shows a permeate tube without membranes. The holes on the tubes are connected with permeate envelopes for permeate passage.

Figure 12 also shows the filter housing, which was created using a 2" diameter, Sch 40 PVC pipe with a machined end cap installed at one end. The end cap has two ports connecting to it. The one at the center is the permeate outlet port and the one located off center is the retentate outlet port. Feed is piped into the housing at the opposite end of the permeate port.

Quality control (QC) tests were performed on the two cartridges by wetting the cartridges in the jet fuel and introducing compressed air (1 psi) to the permeate tube to check if there are any leaks through the epoxy bonding lines in the cartridges or if there are any pin-holes on the membranes. Both cartridges passed the QC tests.

#### **II.2.4 Spiral-wound Cartridge Hydraulic Performance Evaluation**

A test was performed on the two cartridges described above. The purpose of this test is to compare the flux rate between the two different structures. Since the flux rate is expected to be high, the flow passage created by a single layer of tricot may cause high flow resistance to the permeate flow and thus affect the flux rate. The JP-8 acquired from Navair at Lake Hurst was used in the test. All test data and charts are attached in Appendix B. Test B-1 was done on the cartridge with a single layer of Tricot and Test B-2 was done on the cartridge with double layers of Tricot. Note that the trans-membrane pressure was calculated based on the average of the feed and retentate pressure minus the permeate pressure, which is zero (atmospheric pressure). The flux in terms of GPM per square foot of membrane area was calculated based on the

measured permeate flow rate divided by the membrane area of the tested cartridge, which was around 4.5 ft<sup>2</sup> (there will be a minor difference between cartridges).

The chart shown in Figure B-1 was created (based on the results of Tests B-1 and B-2) to compare the permeate flow rate as a function of trans-membrane pressure of the two different permeate envelopes. Based on the test results, it is clear that the double tricot layer design has a higher flow rate. This confirmed our original concern that the system flux rate may be high enough to encounter resistance from the narrow passage created by a single layer of Tricot. The chart in Figure B-1 shows the diverging of the two curves with the increase of the pressure. This makes sense because the flow resistance is in proportion to the flow velocity, which is directly controlled by the trans-membrane pressure.

Test B-3 was done on the cartridge which is similar to the one used in Test B-2 except the opening area in the permeate tube has been doubled. The results of Tests B-2 and B-3 were plotted and shown in Figure B-2. Figure B-2 shows that the flux rate from both tests were almost identical. This means that the opening area in the permeate tube is sufficient and does not cause any flow restriction for the cartridge used in Test B-2. Therefore doubling the opening area in the permeate tube did not change the flux rate. Based on the three tests discussed above, the cartridge design in Test B-2 will be used as the reference for future filter cartridge designs.

### **II.3 TEST LOOP DESIGN AND SETUP**

The test loop was designed and the setup is shown in Figure 14. The process and instrument diagram (P&ID) of the test loop is shown in Figure 15. To ensure minimum flow resistance in the loop, the piping size was maintained at 3/4" wherever it was possible. Two flow meters are included in the setup, one for the feed flow and the other for the retentate flow. Pressure gauges are located at the inlet and outlets of the filter housing. The completed test loop has been hydro tested to ensure the system has no leakage and can withstand a test pressure up to 75 psi.

It is expected that the temperature will increase significantly with a centrifugal pump circulating the process fluid in a closed-loop containing a small volume of jet fuel (10 gal - 20 gal). Therefore a water-cooled heat exchanger is included in this test loop to keep the temperature constant. A 30-gallon cone-shaped tank is used in the loop. The fluid is pumped out from the bottom of the tank. Therefore any water or contaminant settlement will be cycled back to the test system and the test cartridge will constantly "see" the water and contaminants during the test.

Since the test fluid is jet fuel, static electricity could be an issue during the test. Precautions were made to ground all test components to prevent any unexpected discharge. The motor to drive the pump has an explosion-proof rating. From our previous experience, high amounts of static electricity are likely to accumulate on the outside of the PVC housings when a very high feed rate is experienced. This static electricity was probably generated by the turbulence or friction of fluid on the housing and cartridge surfaces due to high velocities, especially at the housing entrance. Since static electricity is a big concern in the design and operation of a jet fuel filtration system, a pre-test run was performed to ensure there was no static electricity problem in the test loop.

The pre-test shows that static electricity was not observed when the feed flow rate was less than 6 GPM, but significantly increased when the feed rate was higher than 10 GPM. The 1.5" OD X 20" (in length) spiral cartridge with the 2" diameter PVC housing is normally designed for handling feed rates from 2 GPM to 5 GPM. Therefore, static electricity should not be generated under the normal running conditions. This test loop is ready for performance testing.

## **II.4 QUALIFICATION METHODS FOR TEST RESULTS**

To ensure the effectiveness of the designed filtration system, the quality of the filtered fuel shall be investigated following recognized standard test procedures. The two major concerns for fuel quality are the solids and water content. The acceptable criteria for the fuel quality are 1) less than 5 PPM for water content and 2) less than 2 mg/liter for sediment.

The standard test procedures described in ASTM D 5452-98, which is specified by MIL-DTL-5624T will be used as the test method for particulate contamination. The method is a gravimetric method which measures the mass of the particulate contaminants removed by a given filtration system in a given volume of feed flow.

ASTM D 3240, which describes the standard test method for undissolved water in aviation turbine fuels, will be followed. This method uses a standard test pad (coated with sodium fluorescent dye) to test the sample. The test pad is then compared to a known standard, while both are illuminated by the same source of UV light. Standard test pads are available on the market, which will cover a test range from 0 to 60 ppm of undissolved water.

Real fuel oil samples supplied by the Navy has been used in the Phase I test. The content of water and Arizona test dust (ISO 12103) were used as parameters in the test. One other significant parameter that was used in the test was trans-membrane pressure. Benchmark tests were performed based on the chosen parameters for the proposed filtration system. The flux rate and the effectiveness of solids and water separation are documented and discussed in the next section.

## **II.5 RESULTS AND DISCUSSION**

### **II.5.1 Water Separation Performance Evaluation**

The Gore 0.1 $\mu$ m PTFE membrane filter cartridge with double layers of Tricot for the permeate envelope (the one used in Test B-3) was used for the water separation performance evaluation. Consecutive tests were carried out with different levels of water content in the feed starting from 0.5% (5,000 PPM), then 1%, 3%, until 5% (50,000 PPM). The tests were labeled as Test B-4 to Test B-7 respectively and the results are attached to the back of this report. Since a cone-shaped tank was used in the test loop and the feed was pumped to the system from the tank bottom, it is guaranteed that any separated (settled) water would be circulated back to the system to maintain the water content at the designated testing level. The circulating pump in the test loop is a centrifugal pump running at 3550 RPM. The high shear force of the centrifugal pump would keep the water emulsified in the tested JP-8. This would make the water separation much more difficult and could truthfully challenge the tested filter cartridge. In each test, the FSII content in

the feed and permeate was measured. The water content in the feed was also checked using an Aqua-Glo water detection kit (ASTM D3240) in each test.

The results of Tests B-3 to B-7 were charted as shown in Figure B-3. The results showed that the flux rate had the most noticeable change when the water content of the feed was changed from no water (0%) to 0.5% of water. When the water content was above 1% (between 1% and 5%), the flux rate change was insignificant. When emulsified water droplets exist in JP-8, they are not able to penetrate into the hydrophobic membrane of the filter cartridge, and they tend to deposit on the membrane surface under the feed pressure. Most of the deposited water droplets will be carried away (to prevent blocking of the membrane pores) by the shear force created by the cross-flow in this spiral-wound filter cartridge design. However, a thin layer of deposits (mostly water) will form on the membrane surface causing the flux rate to decrease. This explained why there was a significant difference of the flux rate between the feed with water and without water. When the water content in the feed was increased, the thickness of the thin layer of water on the membrane surface would increase accordingly. However, the shear resistance of the flow boundary layer (composed of the thin layer of water) is the highest on the membrane surface, and the resistance reduces dramatically with the increase of the distance away from the membrane surface. Therefore the flux rate will not change significantly when the water content in the feed is above a certain level. This explains why the flux rate did not have any significant difference when the water content in the feed was above 1%.

The water content check in the permeate of all four tests ranged from 1 to 2.5 PPM, which were all within the acceptable level of less than 5 PPM based on the Aqua-Glo water detection kit (ASTM D3240).

All tests performed so far were on Gore 0.1  $\mu\text{m}$  PTFE membrane cartridges. A Tetratex 0.1  $\mu\text{m}$  PTFE membrane cartridge was created using the same design as the Gore cartridge. The Tetratex membrane has a polyester backing which is chemically compatible with jet fuel. Test B-8 was performed on the Tetratex cartridge using the same feed as in Test B-7. A chart was created in Figure B-4 to compare the performance between the Gore and the Tetratex membrane cartridges using the same feed, which contained 5% water. The comparison showed that the Tetratex cartridge had a better flux rate than the Gore cartridge. Note that although both membranes were Teflon membranes, the two membranes had different backing materials and bonding that might affect the flux rate. More Teflon membranes with different backing materials and bonding methods should be tested to find the optimum membrane design for this application. This shall be one of the tasks in the Phase II project.

## **II.5.2 Solids Separation Performance Evaluation**

The effect of dust in the feed was also investigated using the Tetratex 0.1  $\mu\text{m}$  PTFE membrane filter cartridge with double layers of Tricot for the permeate envelope. The Tetratex cartridge and the feed with 5% water from Test B-8 were used for the solid separation test. Test B-9 was performed with the addition of 50 mg/liter coarse grade Arizona test dust (ISO 12103-A4), which has a solid particle size distribution from 1 to 200  $\mu\text{m}$  by volume. Test 10 was a continuation test of Test 9 with the addition of another 50 mg/liter fine grade Arizona test dust (ISO 12103-A2), which has a solid particle size distribution from 1 to 120  $\mu\text{m}$  by volume. This

made the total dust content in Test B-10 accumulated up to 100 mg/liter. Note that the flux rate was reduced by about 10% from 0 to 50 mg/liter and remained the same from 50 to 100 PPM based on the trans-membrane pressure of 13 psi. In each test, the running condition was maintained for at least one hour, therefore the flux rate should have been stabilized.

Figure B-5 compares the test results without solids and with 100 mg/liter solids (both tests with 5% water) in the feed as a function of trans-membrane pressure. The flux rate was reduced by about 15% at the trans-membrane pressure of 30 psi. This phenomenon is similar to the separated water droplets, in which solids tend to deposit on the membrane surface under the feed pressure. Most of the deposited solids will be carried away by the shear force created by the cross-flow in this spiral-wound filter cartridge design.

Figure 16 shows the feed versus permeate based on the JP-8 feed with 5% water and 100 PPM test dust passing through a 0.1  $\mu\text{m}$  PTFE membrane.

For feed with high solid-lading conditions, it is a common practice to add a fine-meshed strainer in line with the feed before entering the cartridges. The idea is similar to adding a strainer before a pump suction line for mechanical protection. We may incorporate a strainer into our design depending on the feed quality.

### **II.5.3 Investigation of FSII Concentration Level in Feed and Permeate Under the Effect of Various Water Content in Feed.**

The content of the deicing agent, FSII, was checked in both the feed and the permeate samples in Test B-3 (no water added in the feed) using the B/2 anti-icing additive test kit. The test results showed that the deicing agent concentration in both the feed and permeate were 0.105% (v/v). This means that there was no or negligible FSII depletion during the filtration process under the condition of no water in the tested JP-8 fuel. Note that all the FSII measurements will be percentage in volume and the v/v symbol will be neglected in the rest of the report.

In Test B-4 (0.5% water in the feed), 0.05% of FSII was added to the feed along with 0.5% of water at the beginning of the test. The FSII level in the feed was measured to be 0.118%. The FSII level measured in the permeate of Test B-4 was only 0.068%. Apparently, the measured FSII concentration in the feed is lower than the expected level, which should be about 0.15% (0.05% + 0.105%). This is because FSII is totally soluble in water. When a small amount of water was added to the feed, FSII is extracted from the fuel to the water. This same principle affects the B/2 anti-icing additive test kit for measuring water content in fuel. To measure the FSII content in the feed, 2 ml of water are required to be added in a 160 ml-sample of the feed. If water is added to the feed, then the total volume of water in the sample would be greater than 2 ml since excess water is carried over from the feed. As a result, the FSII is diluted in the sample, showing a lower measured number using the B/2 anti-icing additive test kit.

FSII as a deicer functions such that it is completely soluble in water to prevent the water from freezing. Since FSII has a much higher solubility in water than fuel, it would be separated by the hydrophobic membrane once it dissolves in water. Only the undissolved part of the FSII passes through the membrane. Therefore when there is a high content of water in the system, FSII has

to be replenished in order to meet the minimum requirement of the fuel spec. This can also be observed in the rest of the tests. As the water content in the feed was increased, all FSII in the fuel eventually dissolved in the water of the feed. Therefore, the FSII contents in the feed show lower numbers as the water contents went up in the feed. The FSII content measurement in the permeate was even less and eventually undetectable when the water content in the feed was 3% and higher. The FSII concentration in the permeate as a function of water concentration in the feed was plotted and shown in Figure B-6.

## II.5.4 Overall Dimension and Weight Estimation

The typical trans-membrane pressure for spiral-wound cartridge applications are in the range of 30 to 50 psi. Based on the test results of the application of 0.1  $\mu\text{m}$  PTFE membranes in the JP-8 fuel with 5% water content and 100 mg/liter equal mixture of ISO 12103 fine and coarse grade test dust, the fuel flux rate is around 0.75 GPM/Ft<sup>2</sup> at the trans-membrane pressure of 30 psi. It is unlikely for the JP-5 fuel from the service tanks, which has been processed through centrifugal purifiers, to have worse quality than this tested fuel quality. Using the flux rate of 0.75 GPM/Ft<sup>2</sup>, which is at the lower end of the typical operating range of trans-membrane pressure for spiral-wound cartridges, as the design criteria will be justified.

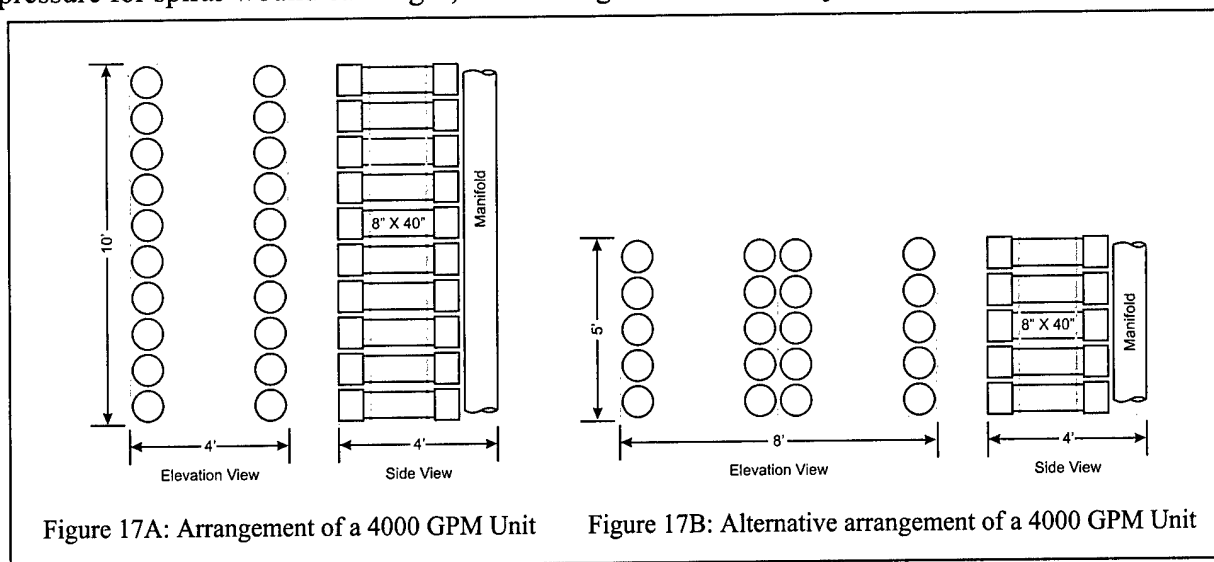

Based on the flux rate of 0.75 GPM/Ft<sup>2</sup>, the membrane area required for a 4000 GPM capacity fuel filtration unit is 5350 Ft<sup>2</sup> (4000 GPM / 0.75 GPM/Ft<sup>2</sup>). The system will be designed using spiral-wound filter cartridges. Assuming 8" x 40" cartridges are used for the design. A typical 8" x 40" cartridge has a membrane area of 280 Ft<sup>2</sup>, and therefore it takes 20 cartridges (5350 Ft<sup>2</sup> / 280 Ft<sup>2</sup>) to achieve the required capacity of 4000 GPM. The arrangement of the 20 cartridges can be as shown in Figure 16A, which gives an overall dimension of 10' x 4' x 4' (160 Ft<sup>3</sup>). An alternative arrangement is shown in Figure 16B, which gives an overall dimension of 5' x 8' x 4' (160 Ft<sup>3</sup>). Based on the arrangement of Figure 16, the overall dry weight of the unit is estimated around 5000 Lbs, and the overall wet weight is around 7500 Lbs. The current 2000 GPM filter unit aboard the aircraft carrier service weighs 10,500 Lbs dry and 22,500 lbs wet and has a volume of 340 Ft<sup>3</sup>. Comparing the proposed 4000 GPM unit design to the current design, the

capacity has been doubled and the weight and volume of the unit is only half that of the current unit. The calculation of the cartridge and system weight estimation is attached in Appendix C.

#### REFERENCES:

1. NSTM Chapter 542, S9086-SP-STM-010, 542-6.2 "Filter/Separator for Mogas & JP-5 Systems"
2. Israelachvili, J. N., "Intermolecular and Surface Forces", *Academic Press, 1985*
3. Tadros, Th. F., "Surfactants", *P. 220-285, Academic Press, 1984*
4. Murkes, J., Carlsson, C. G., "Crossflow Filtration", *John Wiley & Sons, 1988*

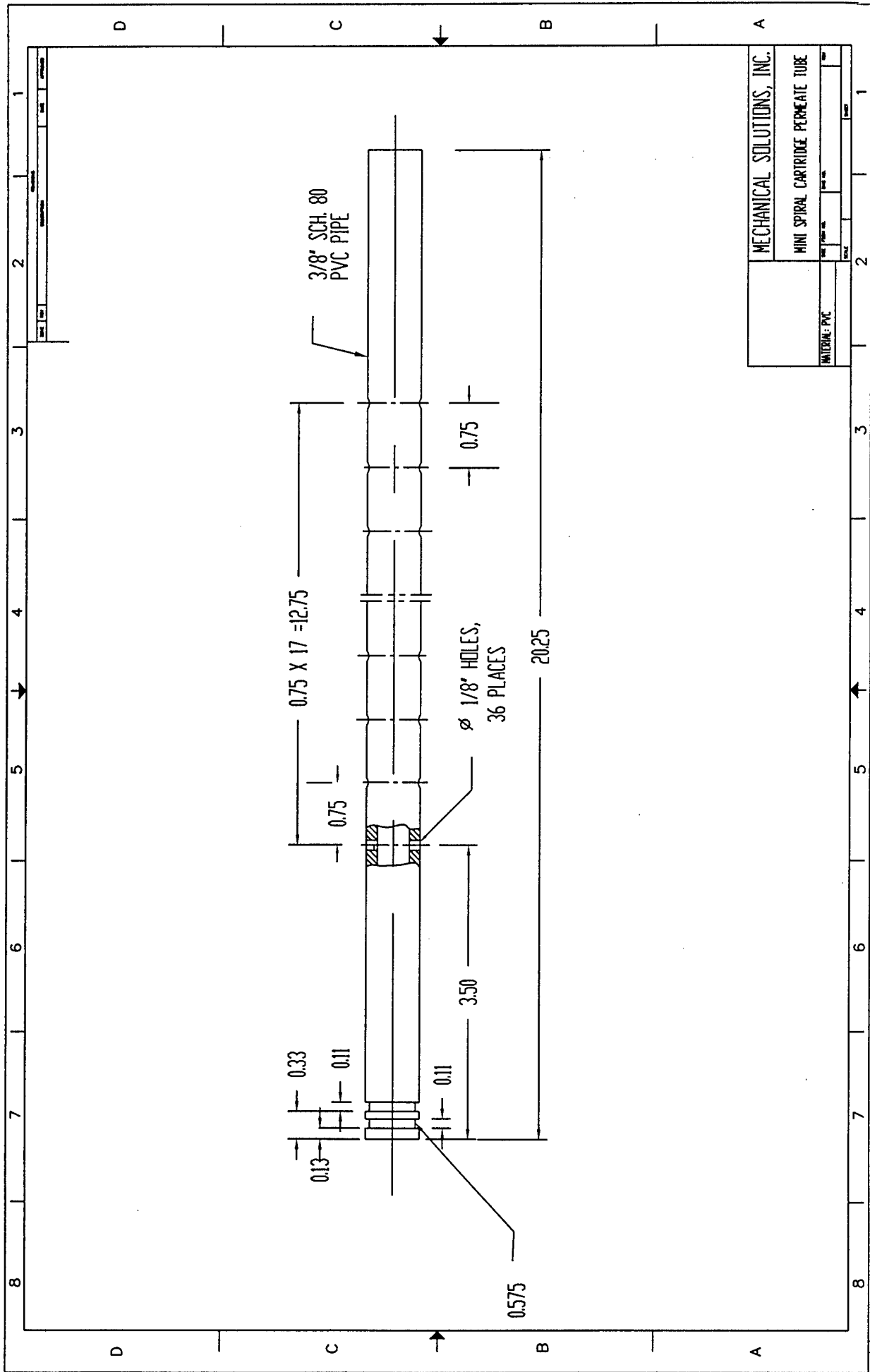

Figure 10: Permeate Tube for Bench-Scale Filter Cartridge

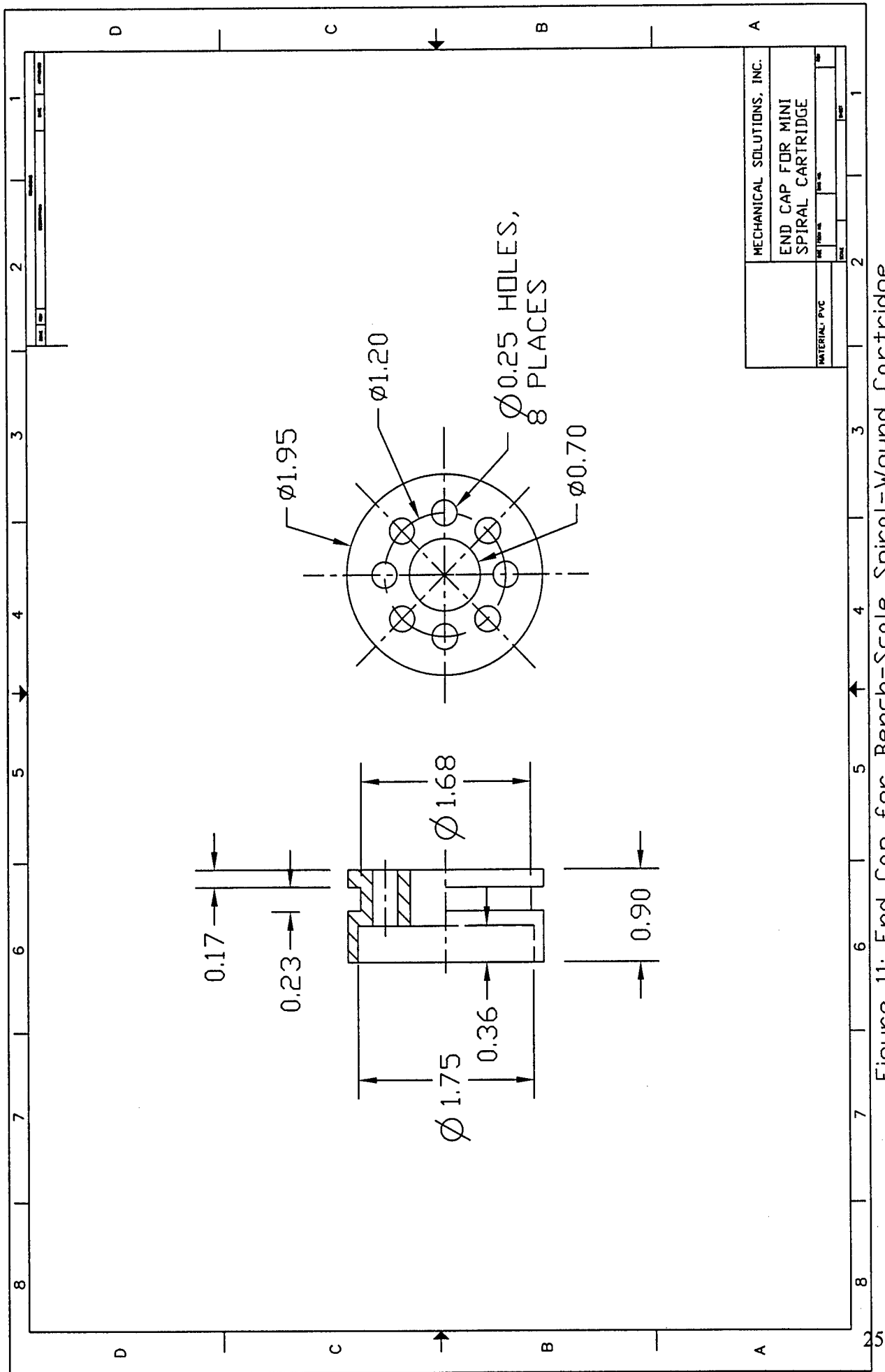
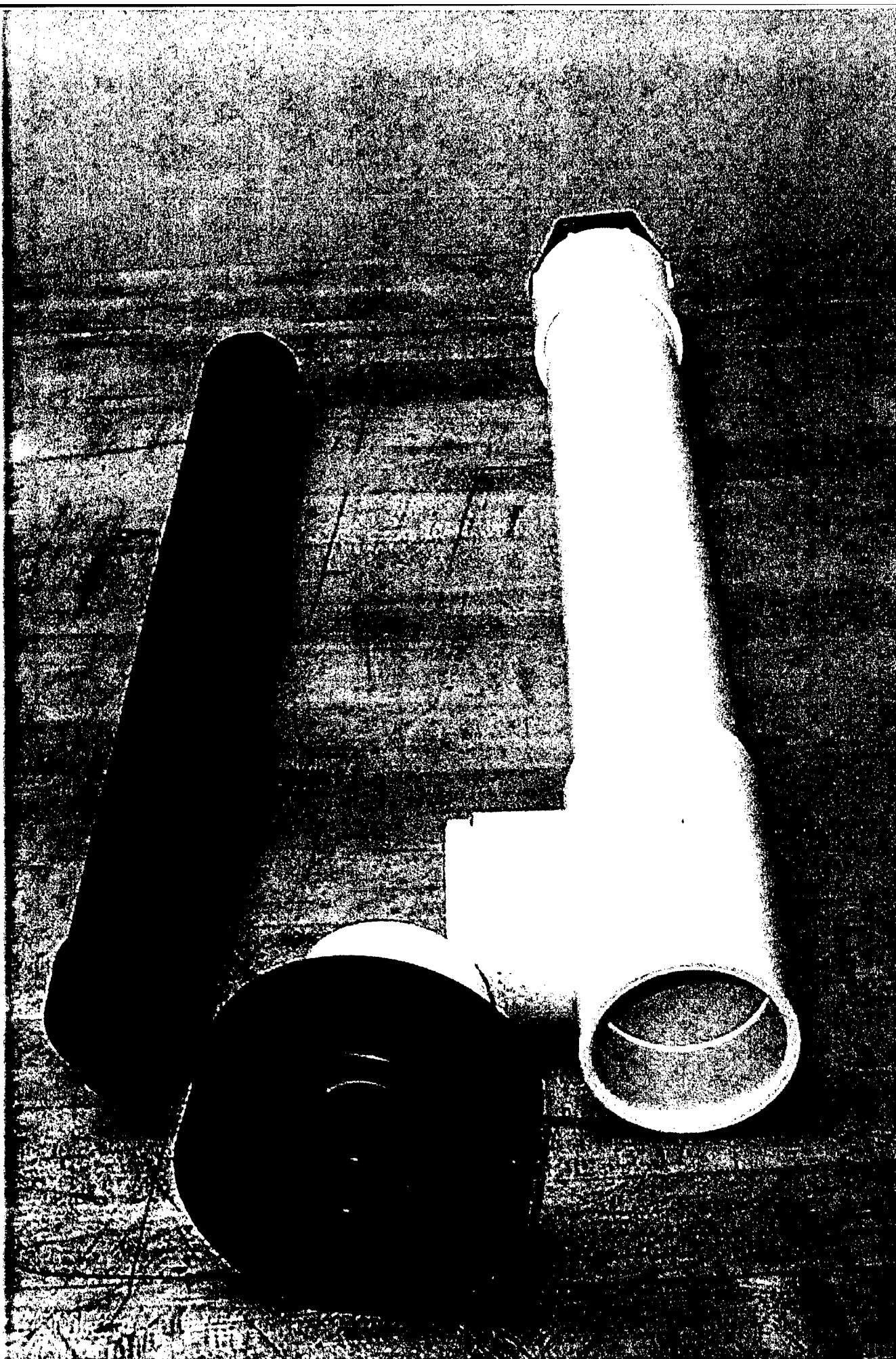
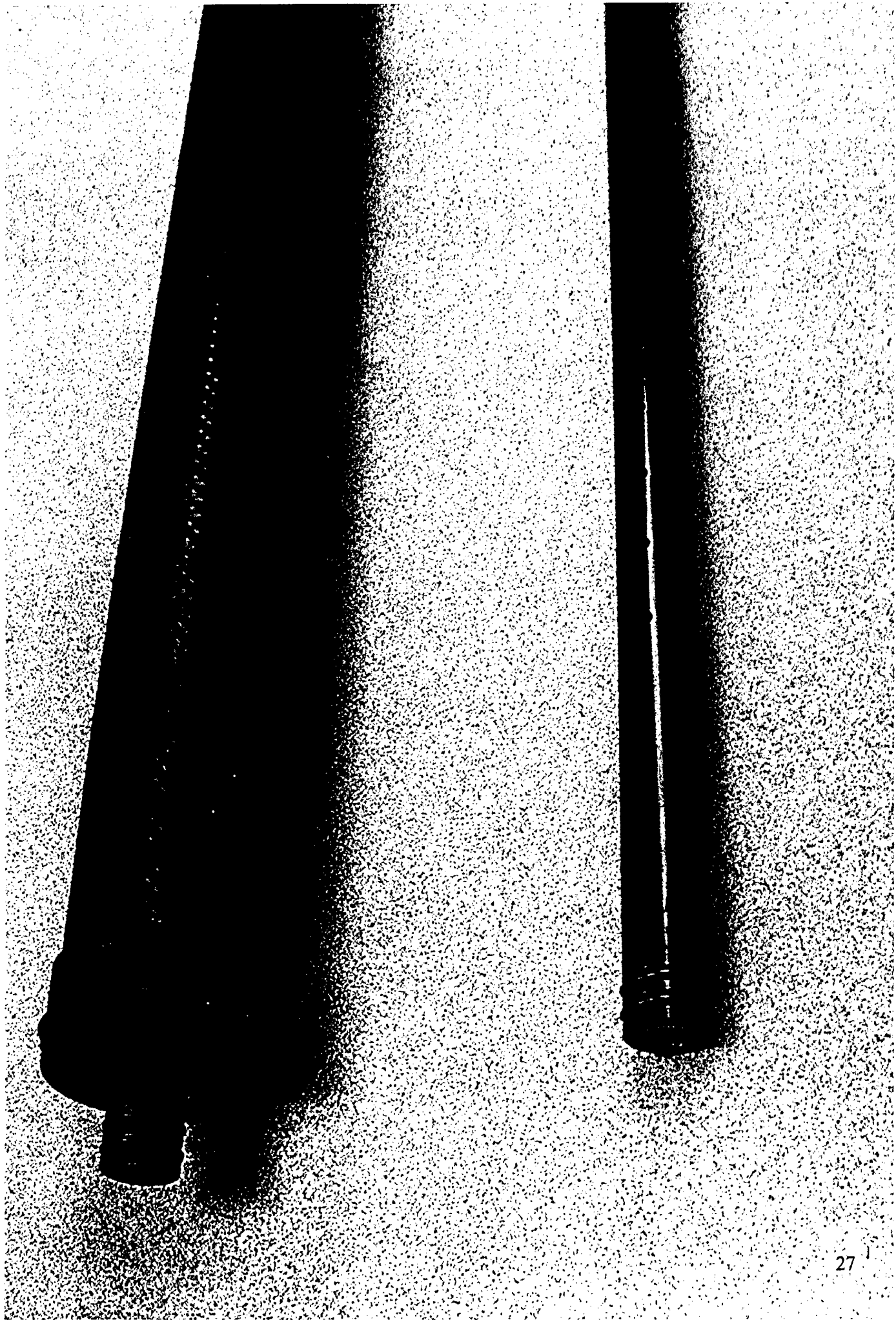

Figure 11: End Cap for Bench-Scale Spiral-Wound Cartridge



**Figure 12: Filter Cartridge and Housing**



**Figure 13: Filter Cartridge and Permeate Tube**

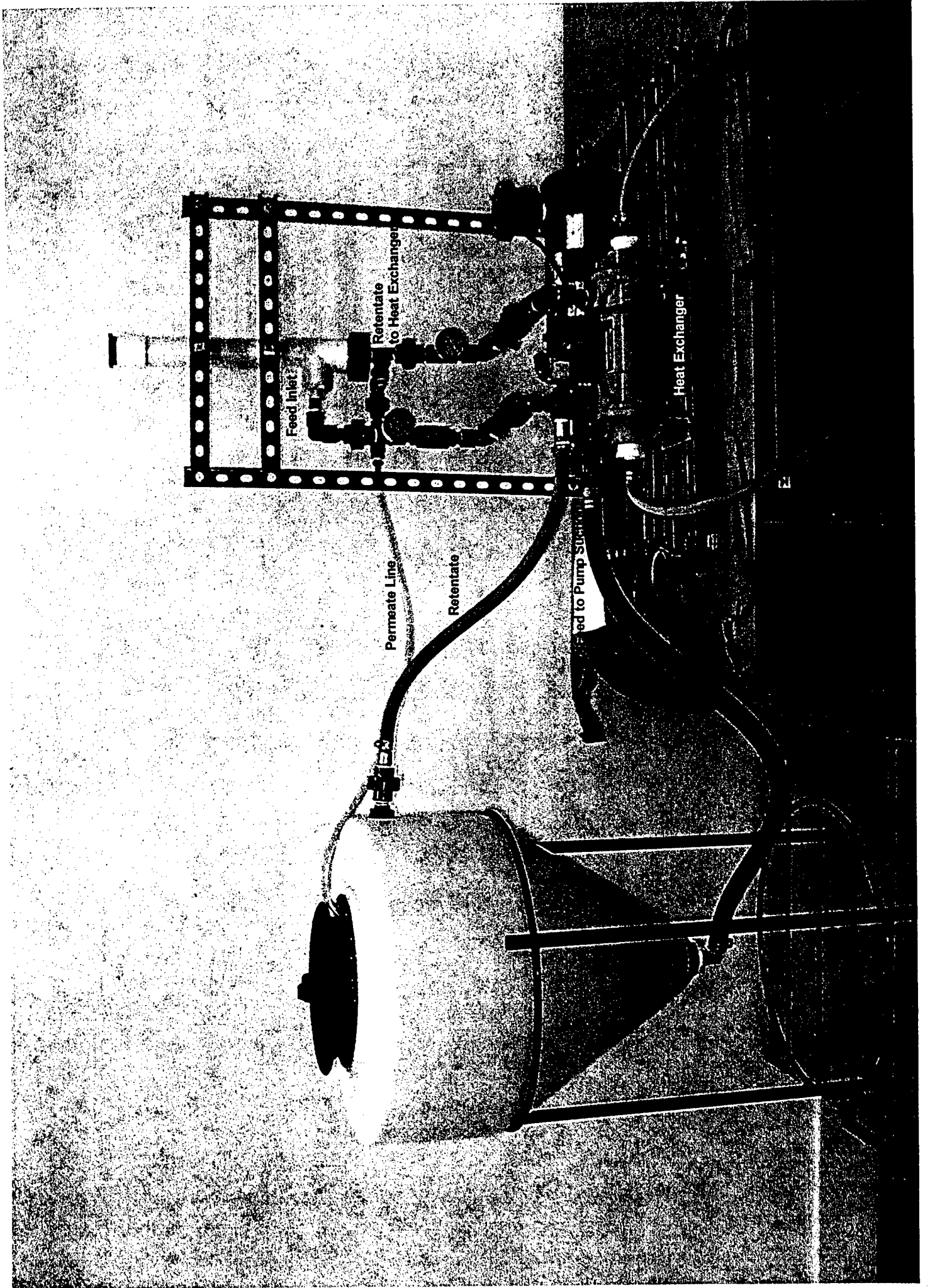
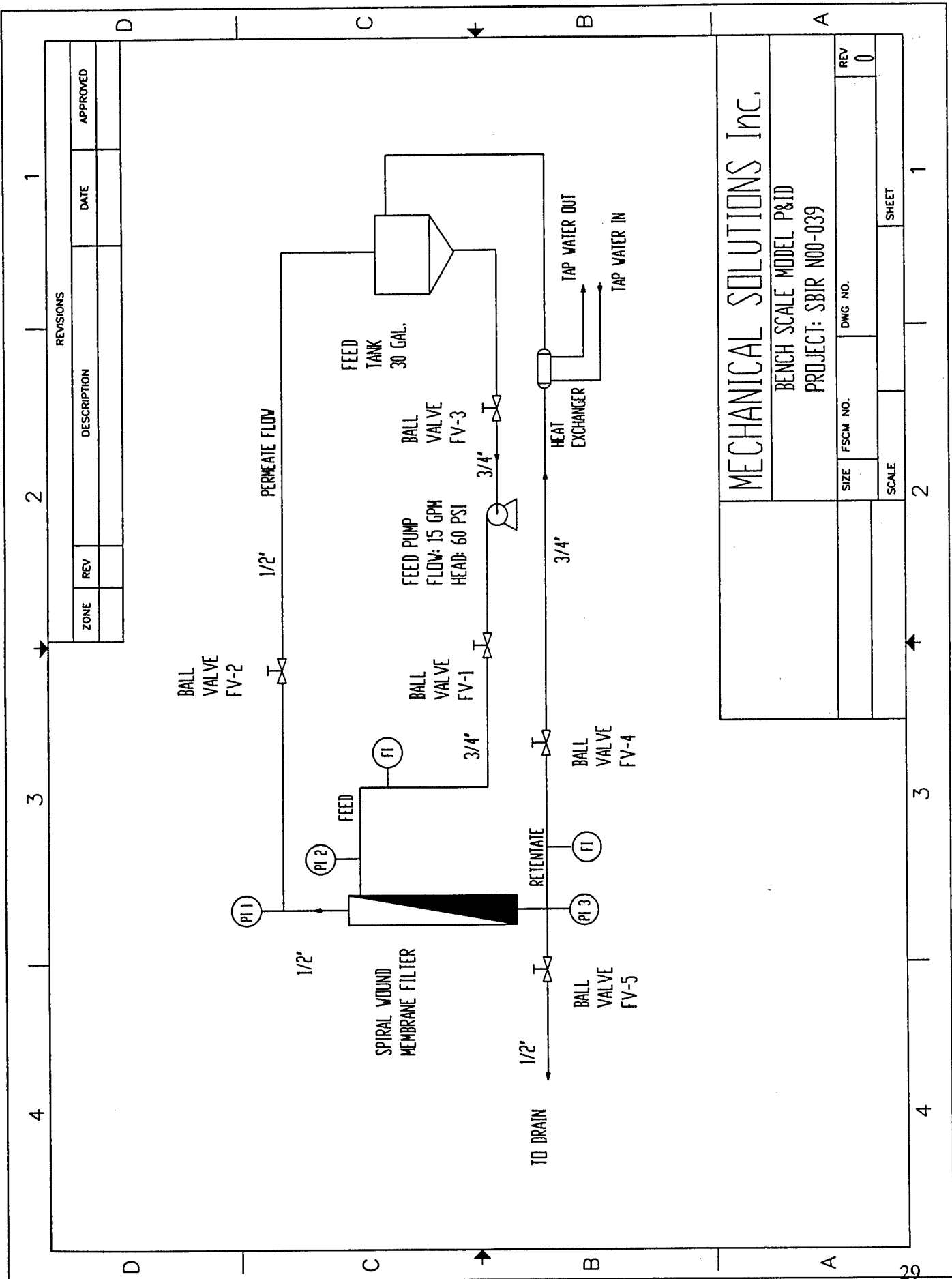

Figure 14: Bench-Scale Test Loop



| REVISIONS |     |             |      |
|-----------|-----|-------------|------|
| ZONE      | REV | DESCRIPTION | DATE |
|           |     |             |      |
|           |     |             |      |

|                           |          |         |       |
|---------------------------|----------|---------|-------|
| MECHANICAL SOLUTIONS INC. |          |         |       |
| BENCH SCALE MODEL P&ID    |          |         |       |
| PROJECT: SBIR N00-039     |          |         |       |
| SIZE                      | FSCM NO. | DWG NO. | REV   |
|                           |          |         | 0     |
| SCALE                     |          |         | SHEET |
|                           |          |         | 1     |

Figure 15: P&ID of Bench-Scale Test Loop

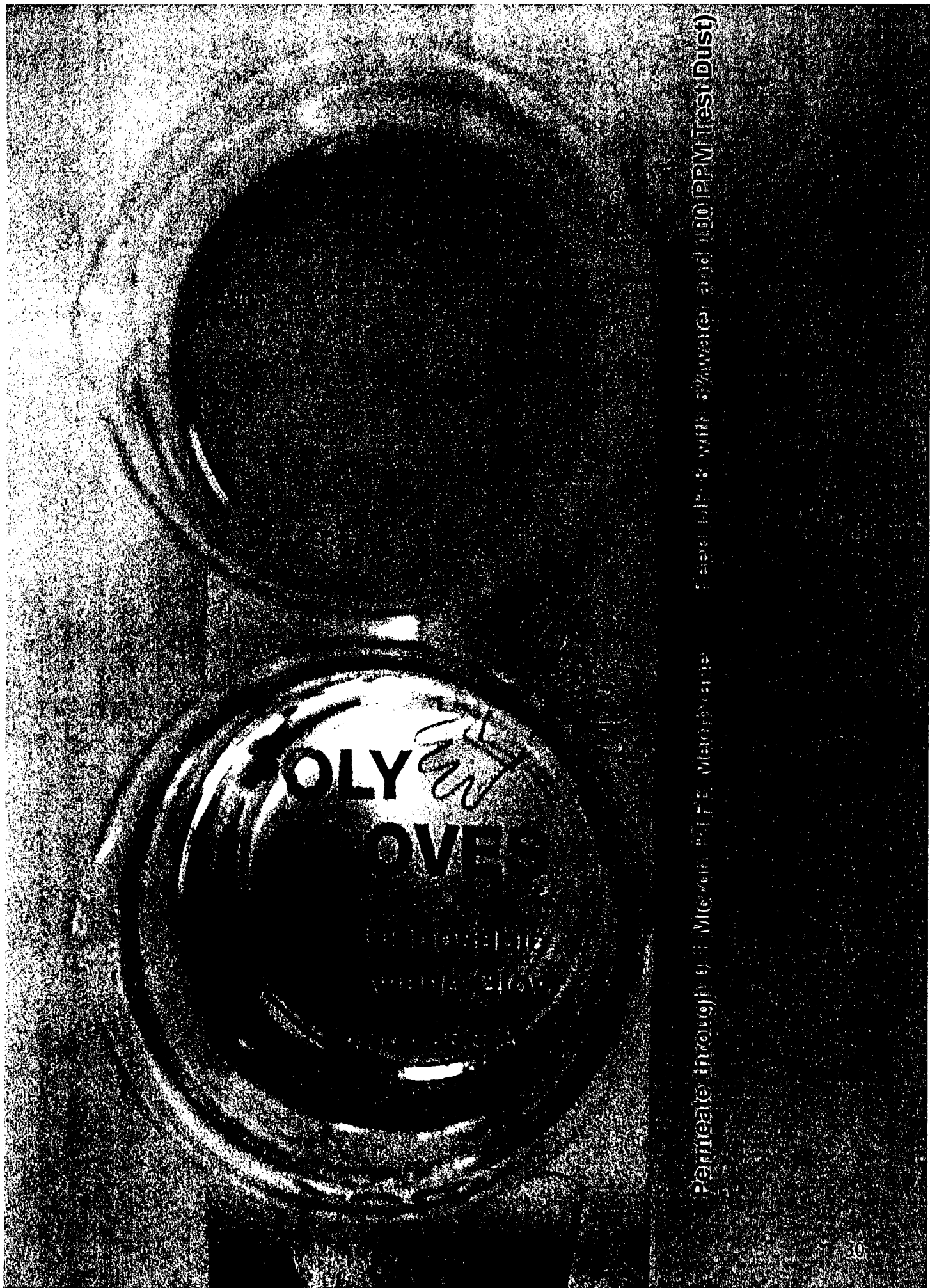

Permeate through 0.1 Micron PTFE Membrane Feed BP 8 with 5% water and 100 PPM Test Dust

Figure 16: Feed vs. Permeate

APPENDIX A - Test Procedures for Anti-Icing Additive (FSII)

## IMPORTANT INSTRUCTIONS

This test kit provides the necessary equipment for determining the percent volume (%v.) of anti-icing additive (AIA, also known as FSII), such as PRIST®, for example, in jet turbine engine fuels.

### Test Method

1. In a clean and dry container procure a pint sample of the fuel to be tested.
2. Set up the apparatus; and fill an aluminum dish one half full of water; tap water is satisfactory. See Fig. 1.
3. With the graduated cylinder transfer **exactly 160 ml.** of the fuel (from Step 1) to the separatory funnel. (Some kits may have instead of the graduated cylinder, a separatory funnel with a line marking the 160 ml. capacity. Fill to that line if the kit is so equipped.)
4. By one of the piston pipets add **exactly 2 ml.** of water to the separatory funnel from the aluminum dish supply. Cap the funnel and shake vigorously for 3 minutes. Then place it in the ring stand.
5. Open the cover of the refractometer's window, make certain it is clean, and apply several drops of water to it, from the aluminum dish supply. Close the cover and through the eye-piece observe the location of the shadow line in the viewer. Remove the plastic rod from the instrument's base, and adjust the set screw (in the base) so that the shadow line intersects the zero line of the scale. See Fig. 2 for a typical condition of a correctly zeroed instrument. Clean cover and window.
6. **Carefully** rotate the separatory funnel's drain cock so that a trickle of fluid can be taken in a clean dry aluminum dish. Two to three drops will be sufficient.
7. Using the same technique as in Step 5, transfer the fluid from the aluminum dish to the refractometer's window, close the cover and observe the position of the shadow line. Fig. 3 shows a typical test result for a JP-4 fuel treated with AIA (FSII) at a .1%v. Your test may show differently as the fuel may have a different %v. of additive, but the reading(s) will be accurate and reflect the fuel's condition.
8. Properly dispose of the liquids, wash the apparatus in soap and water and dry all items. Treat the refractometer as an optical instrument and avoid damage to the lens and window elements.



Figure 1

**REPORT ANY OFF-SPECIFICATION RESULTS TO PROPER AUTHORITIES AT ONCE.**

**(The reverse side offers some possible solutions when off-specifications fuels are involved.)**

© TM PPG Industries, Inc.

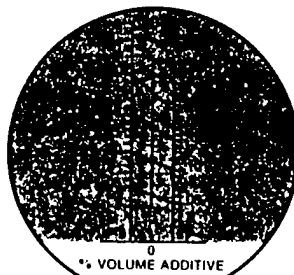
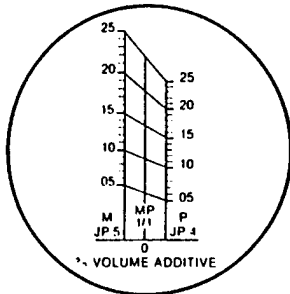

Figure 2

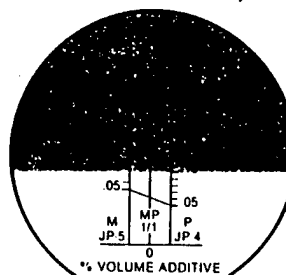

Figure 3

APPENDIX B - Test Data and Charts

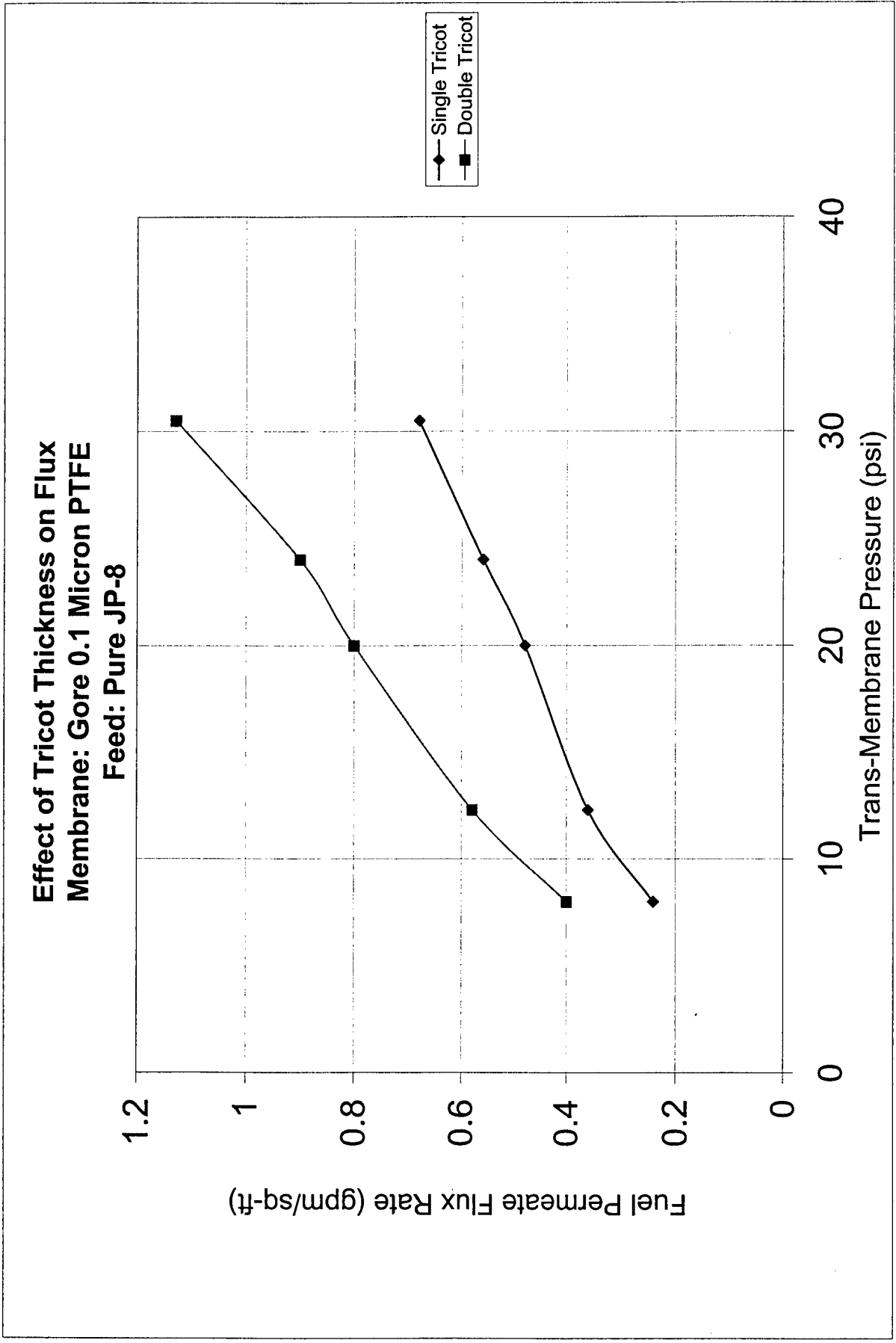

Figure B-1

**Effect of Permeate Tube Opening Area on Flux**  
**Membrane: Gore 0.1 Micron PTFE**  
**Feed: Pure JP-8**

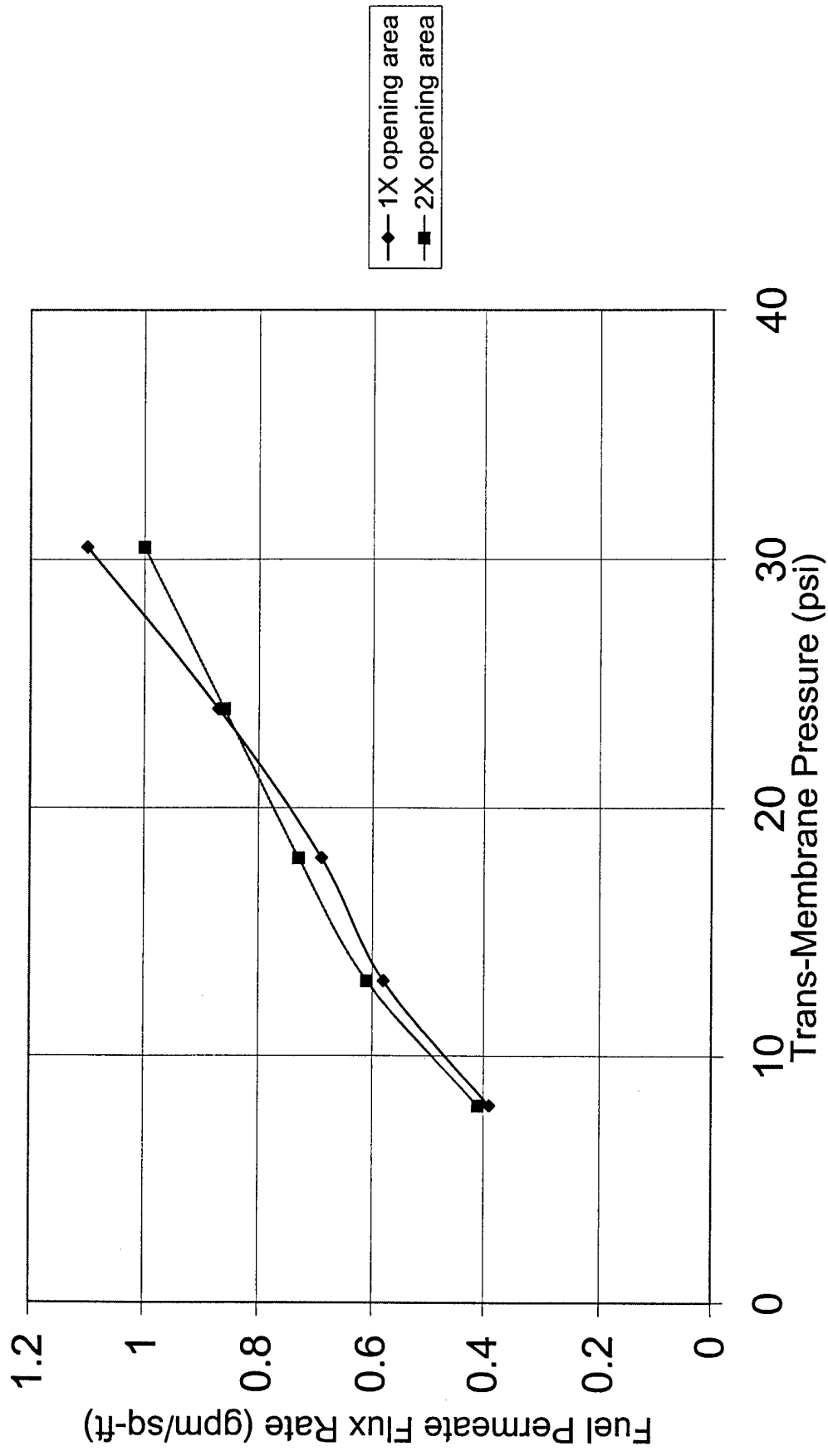

Figure B-2

**Effect of Water Concentration in Feed on Flux**  
**Membrane: Gore 0.1 Micron PTFE**  
**Feed: JP-8 with Water**

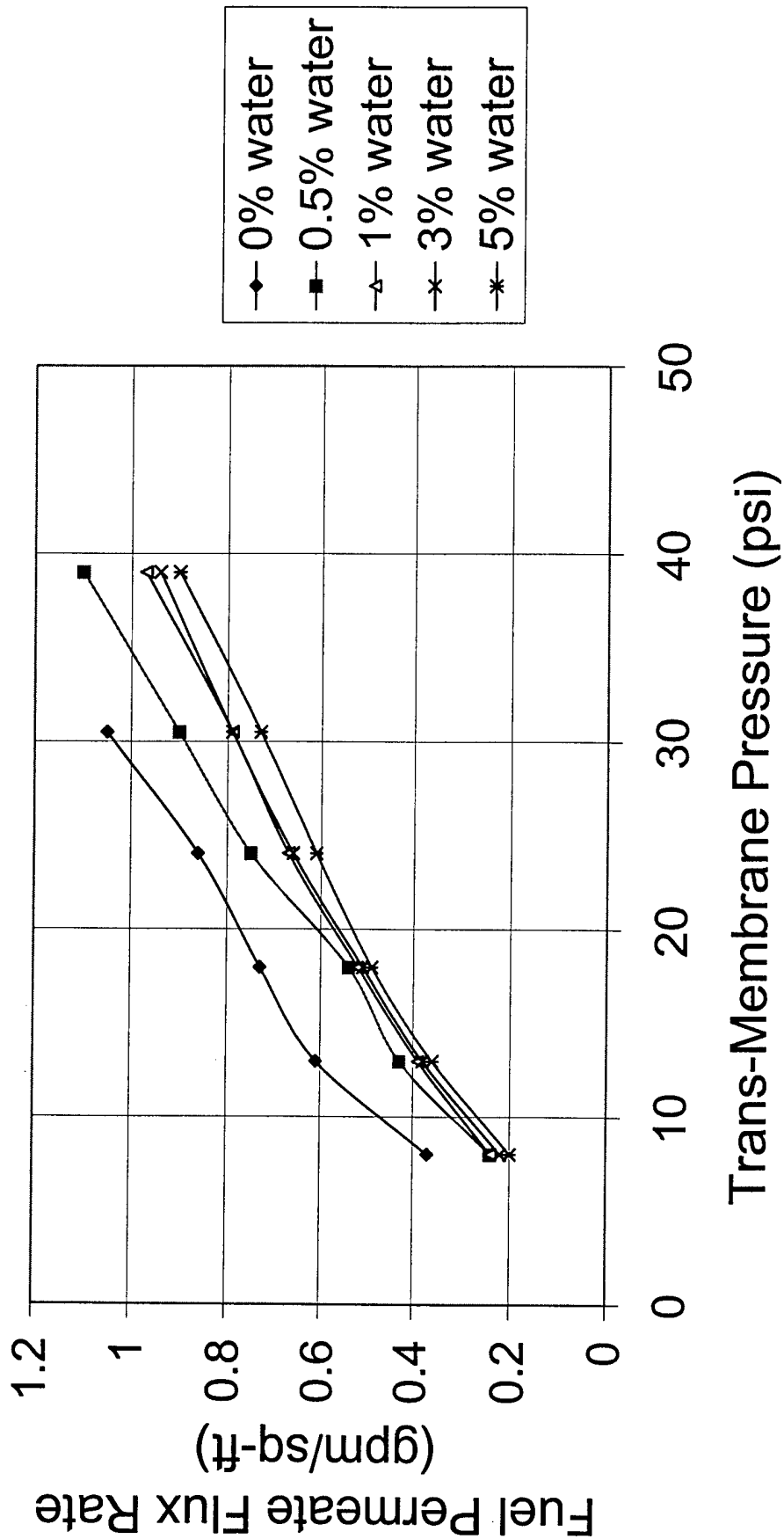

Figure B-3

# Gore Membrane vs. Tetratex Membrane

## Feed: JP-8 fuel with 5% water (v/v)

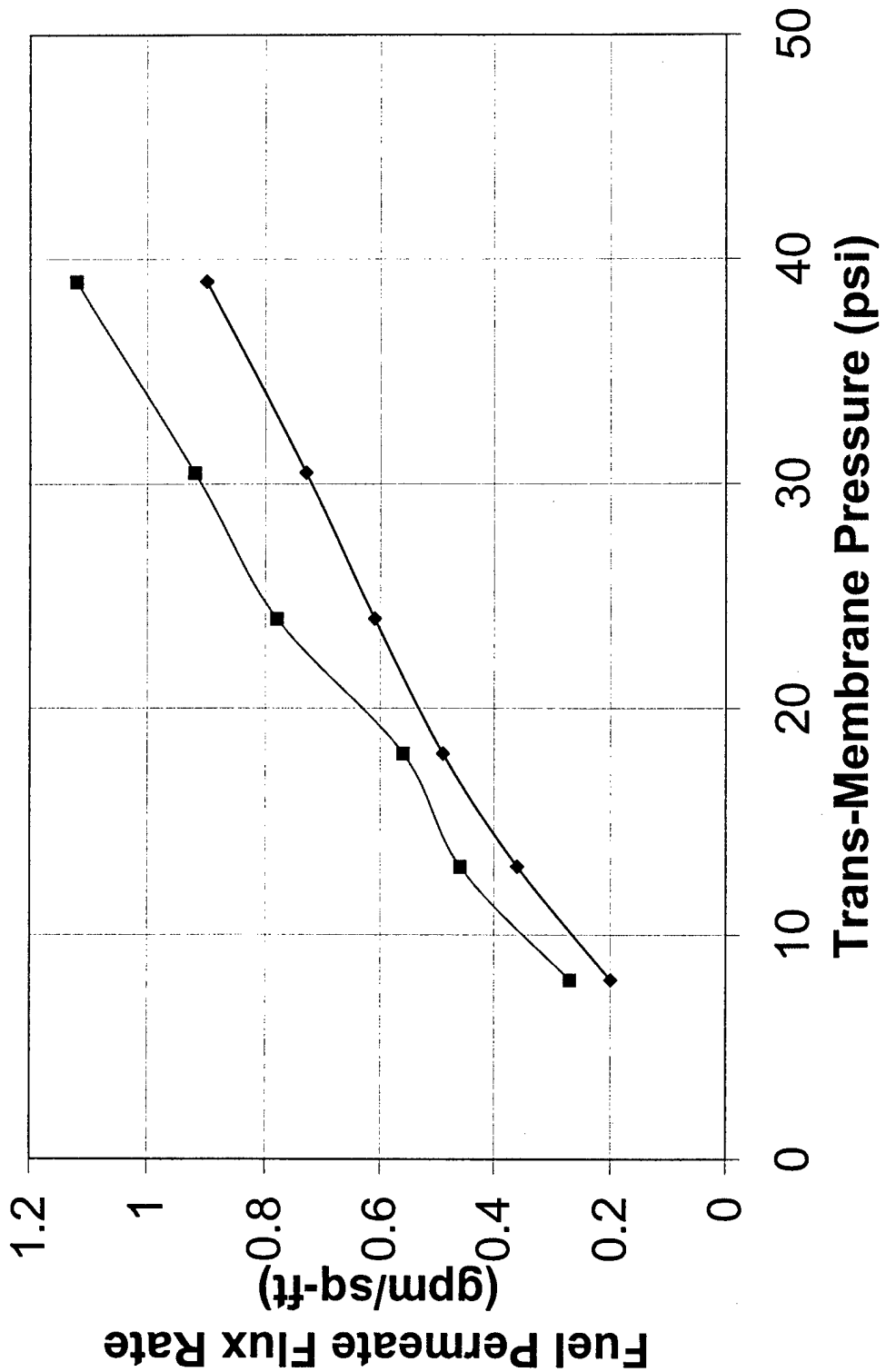

Figure B-4

**Effect of Dust in Feed on Flux**  
**Membrane: Tetratex 0.1 Micron PTFE**  
**Feed: JP-8 Fuel**

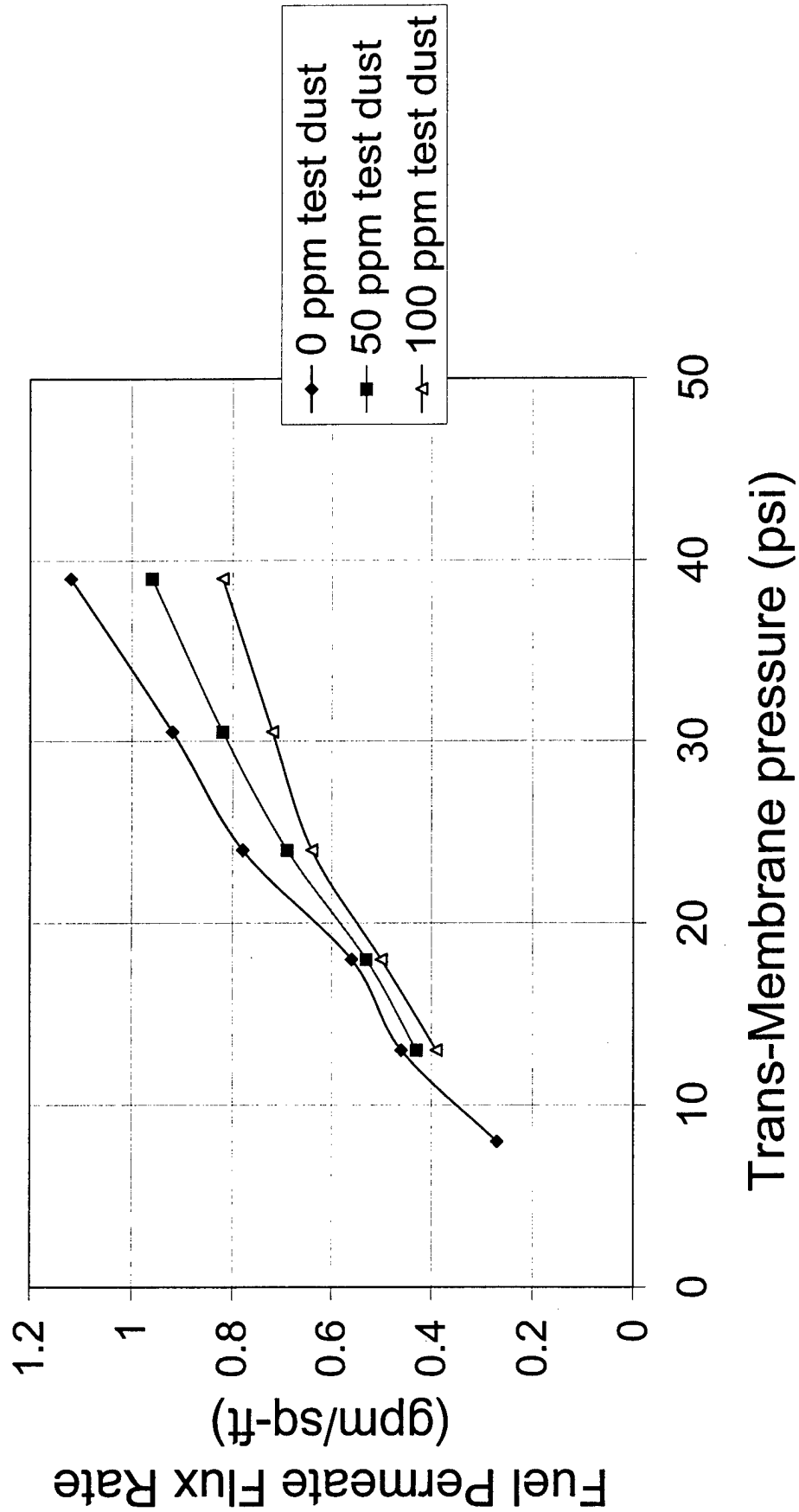

Figure B-5

**Effect of Water Concentrations in Feed  
on FSII Concentrations in Permeate**  
**Membrane: 0.1 Micron PTFE**  
**Feed: JP-8 Fuel**

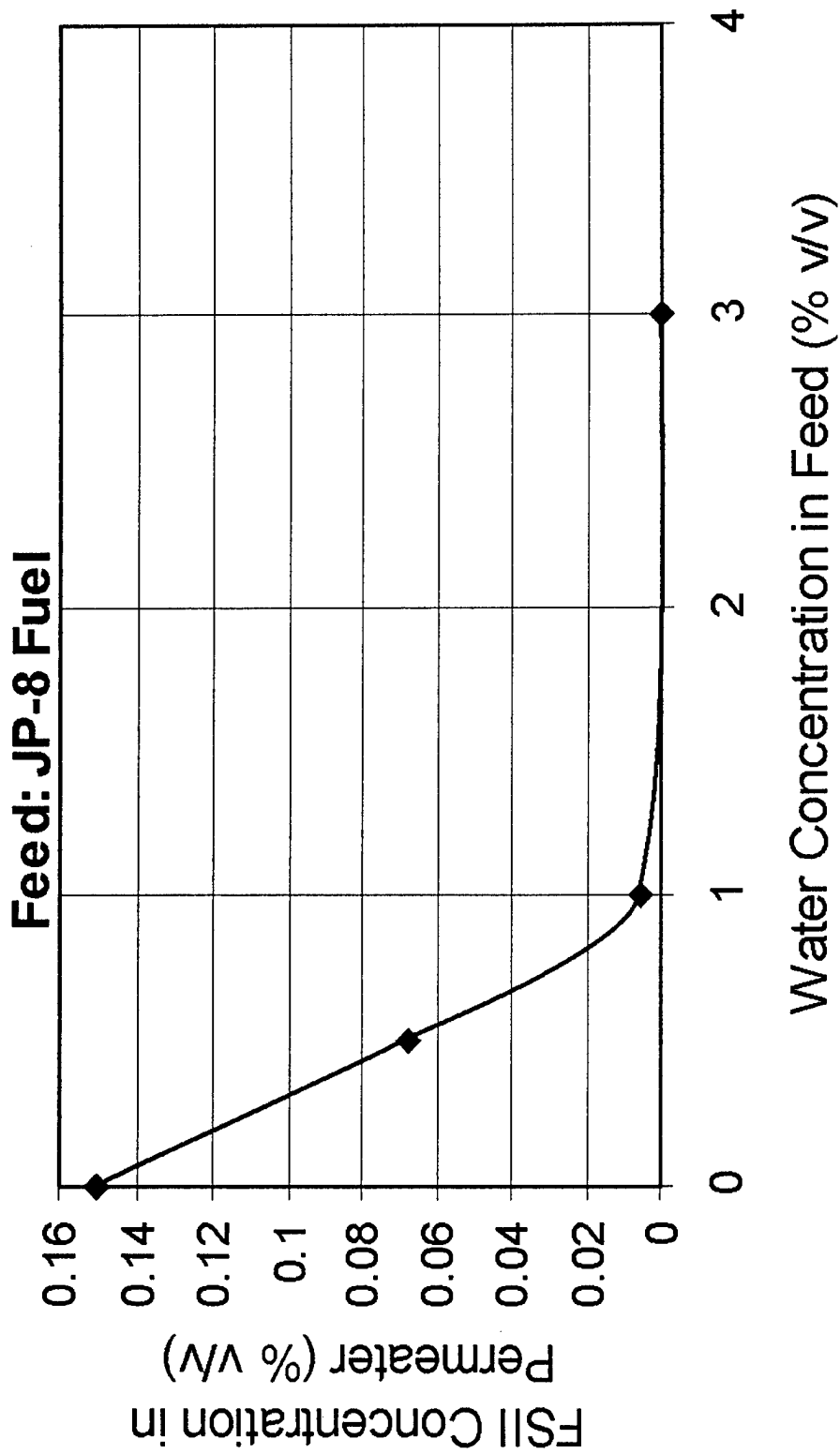

Figure B-6

| Feed Rate (gpm) | Feed P (psi) | Retentate P (psi) | Trans P (psi) | Perm. Rate (gpm) | Flux (gpm/sq-ft) | Permeate P (psi) |
|-----------------|--------------|-------------------|---------------|------------------|------------------|------------------|
| 4               | 9            | 8                 | 8.5           | 1.2              | 0.25             | 0                |
| 5               | 14           | 10.5              | 12.3          | 1.7              | 0.35             | 0                |
| 6               | 22           | 18                | 20            | 2.3              | 0.48             | 0                |
| 6               | 28           | 24                | 26            | 2.9              | 0.60             | 0                |
| 5               | 34           | 31.5              | 32.8          | 3.5              | 0.73             | 0                |

Membrane: Gore 0.1  $\mu$ m PTFE, Feed: JP-8, Membrane Area: 4.8 ft<sup>2</sup>

Test B-1: Effect of Tricot Thickness on Flux (Single Tricot)

| Feed Rate (gpm) | Feed P (psi) | Retentate P (psi) | Trans P (psi) | Perm. Rate (gpm) | Flux (gpm/sq-ft) | Permeate P (psi) |
|-----------------|--------------|-------------------|---------------|------------------|------------------|------------------|
| 4               | 10.5         | 6                 | 8.3           | 1.9              | 0.41             | 0                |
| 5               | 16           | 10                | 13            | 2.8              | 0.61             | 0                |
| 6               | 22           | 14                | 18            | 3.3              | 0.72             | 0                |
| 6               | 28           | 21.5              | 24.8          | 4.3              | 0.93             | 0                |
| 6               | 34           | 27                | 30.5          | 5.2              | 1.13             | 0                |

Membrane: Gore 0.1  $\mu$ m PTFE, Feed: JP-8, Membrane Area: 4.6 ft<sup>2</sup>

Test B-2: Effect of Tricot Thickness on Flux (Double Tricot)

| Feed Rate (gpm) | Feed P (psi) | Retentate P (psi) | Trans P (psi) | Perm. Rate (gpm) | Flux (gpm/sq-ft) | Permeate P (psi) |
|-----------------|--------------|-------------------|---------------|------------------|------------------|------------------|
| 4               | 10           | 6                 | 8             | 1.8              | 0.41             | 0                |
| 5               | 16           | 10                | 13            | 2.7              | 0.61             | 0                |
| 5.5             | 22           | 14                | 18            | 3.2              | 0.73             | 0                |
| 6               | 28           | 20                | 24            | 3.8              | 0.86             | 0                |
| 6               | 34           | 27                | 30.5          | 4.3              | 0.98             | 0                |

Membrane: Gore 0.1  $\mu$ m PTFE, Feed: JP-8, Membrane Area: 4.4 ft<sup>2</sup>, Permeate Tube Outlet Opening Area: 2X of Test 2

Test B-3: Effect of Permeate Tube Opening Area on Flux (Double Tricot, 2X Opening Area)

| Feed Rate (gpm) | Feed P (psi) | Retentate P (psi) | Trans P (psi) | Perm. Rate (gpm) | Flux (gpm/sq-ft) | Permeate P (psi) |
|-----------------|--------------|-------------------|---------------|------------------|------------------|------------------|
| 4.0             | 10           | 5                 | 7.5           | 1.06             | 0.24             | 0                |
| 5.0             | 16           | 10                | 13            | 1.90             | 0.43             | 0                |
| 5.5             | 22           | 14                | 18            | 2.38             | 0.54             | 0                |
| 5.5             | 28           | 20                | 24            | 3.43             | 0.78             | 0                |
| 6.0             | 34           | 27                | 30.5          | 4.12             | 0.94             | 0                |
| 6.0             | 44           | 34                | 39            | 4.44             | 1.01             | 0                |

Membrane: Gore 0.1  $\mu$ m PTFE, Membrane Area: 4.4 ft<sup>2</sup> Feed: JP-8 with 0.5% water

Test B-4: Water Separation Test (0.5% water)

| Feed Rate (gpm) | Feed P (psi) | Retentate P (psi) | Trans P (psi) | Perm. Rate (gpm) | Flux (gpm/sq-ft) | Permeate P (psi) |
|-----------------|--------------|-------------------|---------------|------------------|------------------|------------------|
| 4.5             | 10           | 5                 | 7.5           | 1.06             | 0.24             | 0                |
| 5.0             | 16           | 10                | 13            | 1.72             | 0.39             | 0                |
| 5.2             | 22           | 14                | 18            | 2.30             | 0.52             | 0                |
| 5.5             | 28           | 20                | 24            | 2.96             | 0.67             | 0                |
| 5.5             | 34           | 26                | 30            | 3.49             | 0.79             | 0                |
| 6.0             | 44           | 33                | 38.5          | 4.28             | 0.97             | 0                |

Membrane: Gore 0.1  $\mu$ m PTFE, Membrane Area: 4.4 ft<sup>2</sup> Feed: JP-8 with 1% water

Test B-5: Water Separation Test (1% water)

| Feed Rate (gpm) | Feed P (psi) | Retentate P (psi) | Trans P (psi) | Perm. Rate (gpm) | Flux (gpm/sq-ft) | Permeate P (psi) |
|-----------------|--------------|-------------------|---------------|------------------|------------------|------------------|
| 5               | 10           | 5                 | 7.5           | 0.98             | 0.22             | 0                |
| 5               | 16           | 10                | 13            | 1.66             | 0.38             | 0                |
| 5               | 22           | 14                | 18            | 2.26             | 0.51             | 0                |
| 6               | 28           | 20                | 24            | 2.91             | 0.66             | 0                |
| 6               | 34           | 26                | 30            | 3.49             | 0.79             | 0                |
| 6.5             | 44           | 33                | 38.5          | 4.12             | 0.94             | 0                |

Membrane: Gore 0.1  $\mu$ m PTFE, Membrane Area: 4.4 ft<sup>2</sup> Feed: JP-8 with 3% water

Test B-6: Water Separation Test (3% water)

| Feed Rate (gpm) | Feed P (psi) | Retentate P (psi) | Trans P (psi) | Perm. Rate (gpm) | Flux (gpm/sq-ft) | Permeate P (psi) |
|-----------------|--------------|-------------------|---------------|------------------|------------------|------------------|
| 5               | 10           | 5                 | 7.5           | 0.9              | 0.20             | 0                |
| 5.5             | 16           | 10                | 13            | 1.59             | 0.36             | 0                |
| 6               | 22           | 14                | 18            | 2.14             | 0.49             | 0                |
| 6.5             | 28           | 20                | 24            | 2.69             | 0.61             | 0                |
| 6.5             | 34           | 26                | 30            | 3.22             | 0.73             | 0                |
| 6.5             | 44           | 33                | 38.5          | 3.96             | 0.90             | 0                |

Membrane: Gore 0.1  $\mu$ m PTFE, Membrane Area: 4.4 ft<sup>2</sup> Feed: JP-8 with 5% water

Test B-7: Water Separation Test (5% water)

| Feed Rate (gpm) | Feed P (psi) | Retentate P (psi) | Trans P (psi) | Perm. Rate (gpm) | Flux (gpm/sq-ft) | Permeate P (psi) |
|-----------------|--------------|-------------------|---------------|------------------|------------------|------------------|
| 5.0             | 10           | 5                 | 7.5           | 1.11             | 0.27             | 0                |
| 5.0             | 16           | 10                | 13            | 1.90             | 0.46             | 0                |
| 5.5             | 22           | 14                | 18            | 2.48             | 0.60             | 0                |
| 6.0             | 28           | 20                | 24            | 3.20             | 0.78             | 0                |
| 6.3             | 34           | 26                | 30            | 3.79             | 0.92             | 0                |
| 6.5             | 44           | 33                | 38.5          | 4.60             | 1.12             | 0                |

Membrane: Tetratex 0.1  $\mu$ m PTFE, Membrane Area: 4.1 ft<sup>2</sup> Feed: JP-8 with 5% water

Test 8: Tetratex Membrane Water Separation Test (5% water)

| Solid Content | Feed P (psi) | Retentate P (psi) | Trans P (psi) | Perm. Rate (gpm) | Flux (gpm/sq-ft) | Permeate P (psi) |
|---------------|--------------|-------------------|---------------|------------------|------------------|------------------|
| 0 PPM         | 16           | 10                | 13            | 1.82             | 0.44             | 0                |
| 0 PPM         | 20           | 18                | 19            | 2.54             | 0.62             | 0                |
| 0 PPM         | 16           | 16                | 16            | 2.14             | 0.52             | 0                |
| 50 PPM        | 16           | 10                | 13            | 1.63             | 0.40             | 0                |
| 50 PPM        | 28           | 24                | 26            | 2.70             | 0.66             | 0                |
| 50 PPM        | 44           | 33                | 38.5          | 3.90             | 0.95             | 0                |
| 100 PPM       | 16           | 10                | 13            | 1.63             | 0.40             | 0                |
| 100 PPM       | 28           | 24                | 26            | 2.85             | 0.70             | 0                |
| 100 PPM       | 44           | 33                | 38.5          | 3.40             | 0.83             | 0                |

Membrane: Tetratex 0.1  $\mu$ m PTFE, Membrane Area: 4.1 ft<sup>2</sup> Feed: JP-8 with 5% water

Test 9: Solid Separation Test (5% water)

APPENDIX C - Calculation of Filter Cartridge and System Weight  
of Proposed 4000 GPM Fuel Filtration Unit

## Calculation of Filter Cartridge and System Weight

### Calculation of Cartridge Weight:

Use Sch 80 PVC Pipe for the 8 x 40 Filter Cartridge  
Assuming each cartridge length is 4 Ft

$$\begin{aligned} \text{WTunit} &:= 8.25 \quad \text{Lb/Ft} && \text{Sch 80 PVC Pipe Unit Weight} \\ &&& \text{(8" Gage 12 SS Tube Unit Weight is 8.93 Lb/Ft)} \\ \text{Lcart} &:= 4 \quad \text{Feet} && \text{Length per Cartridge} \\ \text{WThsg} &:= \text{WTunit} \cdot \text{Lcart} \\ \text{WThsg} &= 33 \quad \text{Lb} && \text{Weight per Housing} \end{aligned}$$

For a Mini Cartridge, Membrane Area & Weight

$$\begin{aligned} \text{Amini} &:= 4.5 \quad \text{Ft}^2 \\ \text{WTmini} &:= 0.75 \quad \text{Lb} && \text{Measured from Mini Cartridge} \end{aligned}$$

For an 8 x 40 Cartridge, Membrane Area

$$\begin{aligned} \text{A8} &:= 280 \quad \text{Ft}^2 \\ \text{WT8} &:= \frac{\text{A8}}{\text{Amini}} \cdot \text{WTmini} \\ \text{WT8} &= 46.67 \quad \text{Lb} \end{aligned}$$

Each 8 x 40 Membrane Cartridge Weight

$$\begin{aligned} \text{WTdry1} &:= \text{WThsg} + \text{WT8} \\ \text{WTdry1} &= 79.67 \quad \text{Lb} && \text{Weight of Each Dry Cartridge} \\ \text{WTdry20} &:= \text{WTdry1} \cdot 20 \\ \text{WTdry20} &= 1.59 \cdot 10^3 && \text{Weight of 20 Dry Cartridges} \end{aligned}$$

Estimate of Wet Cartridge Weight:

Volume for Fluid in each 8 x 40 Cartridge

$$\begin{aligned} \text{Dia} &:= 8 \quad \text{in} \\ \text{Length} &:= 40 \quad \text{in} \\ \text{V8} &:= \frac{\pi \cdot \text{Dia}^2}{4} \cdot \text{Length} \cdot \frac{1}{12^3} \quad \text{Ft}^3 \\ \text{Vol} &:= \text{V8} \cdot 80 \% && \text{Assuming 20\% of the volume is occupied by membrane} \\ \text{Vol} &= 0.93 \quad \text{Ft}^3 \end{aligned}$$

Max Specific Weight of JP5 at 15°C is 0.85

$$\text{SpCwt} := 0.85$$

$$\text{Dwater} := 62.4 \quad \text{Lb/Ft}^3 \quad \text{Water Density}$$

$$\text{WTjp5} := \text{SpCwt} \cdot \text{Dwater} \cdot \text{Vol}$$

$$\text{WTjp5} = 49.37 \quad \text{Lb}$$

$$\text{WTwet1} := \text{WTdry1} + \text{WTjp5}$$

$$\text{WTwet1} = 129.04 \quad \text{Lb} \quad \text{Weight of Each Wet Cartridge}$$

$$\text{WTwet20} := \text{WTwet1} \cdot 20$$

$$\text{WTwet20} = 2.58 \cdot 10^3 \quad \text{Weight of 20 Wet Cartridges}$$

#### Calculation of Steel Frame, Piping & Fitting Weight:

$$\text{Lo} := 72 \quad \text{Ft} \quad \text{Overall Steel Frame Length for a 10' x 4' x 4'}$$

$$\text{WTunit} := 9.8 \quad \text{Lb/Ft} \quad \text{Unit Weight of 4 x 4 x 3/8L is 9.8 Lb/Ft}$$

$$\text{WTframe} := \text{WTunit} \cdot \text{Lo}$$

$$\text{WTframe} = 705.6 \quad \text{Steel Frame Weight}$$

$$\text{Lperm} := 30 \quad \text{Ft} \quad \text{Permeate Manifold Length}$$

$$\text{Lret} := 30 \quad \text{Ft} \quad \text{Retentate Manifold Length}$$

$$\text{Lfeed} := 10 \quad \text{Ft} \quad \text{Feed Manifold Length}$$

$$\text{WT8} := 28.55 \quad \text{Lb/Ft} \quad \text{Unit Weight of 8" Sch 40 Pipe}$$

$$\text{WT12} := 49.56 \quad \text{Lb/Ft} \quad \text{Unit Weight of 12" Sch 40 Pipe}$$

$$\text{WTman} := \text{Lperm} \cdot \text{WT8} + \text{Lret} \cdot \text{WT8} + \text{Lfeed} \cdot \text{WT12}$$

$$\text{WTman} = 2.21 \cdot 10^3 \quad \text{Lb} \quad \text{Total Mainfold Weight}$$

$$\text{WTfit} := 500 \quad \text{Lb} \quad \text{Estimate of Misc. Fitting Weight}$$

$$\text{WTdryframe} := \text{WTframe} + \text{WTman} + \text{WTfit}$$

$$\text{WTdryframe} = 3.41 \cdot 10^3 \quad \text{Total Dry Weight of Frame, Piping & Fitting}$$

$$\text{WTdry} := \text{WTdry20} + \text{WTdryframe}$$

$$\text{WTdry} = 5.01 \cdot 10^3 \quad \text{Lb} \quad \text{Total Dry System Weight}$$

### Estimate of Wet Piping & Fitting Weight

D8 := 7.981 in Diameter of 8" Sch 40 Pipe

D12 := 12 in Diameter of 12" Sch 40 Pipe

$$\text{Vol8} := \pi \cdot \frac{D8^2}{4} \cdot \frac{1}{12^2} \cdot (L_{\text{perm}} + L_{\text{ret}})$$

Vol8 = 20.84 Ft<sup>3</sup> Permeate and Retentate Manifold Volume

$$\text{Vol12} := \pi \cdot \frac{D12^2}{4} \cdot \frac{1}{12^2} \cdot L_{\text{feed}}$$

Vol12 = 7.85 Ft<sup>3</sup> Feed Manifold Volume

$$\text{Volman} := \text{Vol8} + \text{Vol12}$$

Volman = 28.7 Ft<sup>3</sup> Total Manifold Volume

$$\text{WTmanjp5} := \text{SpWt} \cdot \text{Dwater} \cdot \text{Volman}$$

WTmanjp5 = 1.52 · 10<sup>3</sup> Lb Total JP5 Weight in Manifold

$$\text{WTwet} := \text{WTwet20} + \text{WTdryframe} + \text{WTmanjp5}$$

WTwet = 7.52 · 10<sup>3</sup> Lb **Total Wet System Weight**