

# REPORT DOCUMENTATION PAGE

AFRL-SR-BL-TR-00-

06001

Public reporting burden for this collection of information is estimated to average 1 hour per response, including gathering and maintaining the data needed, and completing and reviewing the collection of information. Send collection of information, including suggestions for reducing this burden, to Washington Headquarters Services, Directorate for Information Operations and Reports, 1215 Jefferson Avenue, Washington, DC 20540-6001, and to the Office of Management and Budget, Paperwork Reduction Project (0704-0188), Washington, DC 20503-2975.

1. AGENCY USE ONLY (Leave blank)		2. REPORT DATE Sept. 5, 2000	3. REPORT TYPE AND DATES COVERED Final Technical Report; 1/1/1998-03/31/1999	
4. TITLE AND SUBTITLE Aeroelasticity and Aeroservoelasticity of Uninhabited Long Endurance Aircraft			5. FUNDING NUMBERS F49620-98-0131	
6. AUTHORS Peretz P. Friedmann				
7. PERFORMING ORGANIZATION NAME(S) AND ADDRESS(ES) University of California Mechanical and Aerospace Engineering Department 48-121 Engineering IV Los Angeles, CA 90095-1597			8. PERFORMING ORGANIZATION REPORT NUMBER	
9. SPONSORING/MONITORING AGENCY NAME(S) AND ADDRESS(ES) Air Force Office of Scientific Research AFOSR/NA 801 N. Randolph Street, Room 732 Arlington, VA 22203-1977			10. SPONSORING/MONITORING AGENCY REPORT NUMBER	
11. SUPPLEMENTARY NOTES				
12a. DISTRIBUTION/AVAILABILITY STATEMENT  Approved for public release; distribution unlimited			12b. DISTRIBUTION CODE	
13. ABSTRACT (Maximum 200 words)  This report describes the research that has been conducted on the above referenced grant during the last nine-month period. The principal accomplishments during this time period are listed below: <ul style="list-style-type: none"> <li>• Collected typical data such as wing mass and stiffness distributions, geometric information and bending and torsional frequencies on HALE type vehicles such as Global Hawk, Darkstar, U-2, etc. and used it to develop an ordering scheme, utilizing non-dimensional parameters, for this class of vehicles.</li> <li>• Developed simple structural dynamic/aeroelastic model for HALE type vehicles with isotropic wings undergoing moderate deflections in bending (normal to wing plane and chordwise), and torsion, and rigid body motion (plunge, pitch and fore and aft motion) using one mode for each elastic degree of freedom.</li> <li>• Developed procedure for coupling the unsteady aerodynamic loads obtained from CFD with the structural dynamic model.</li> <li>• Established fundamental scaling aeroelastic relations for testing this class of vehicles in a conventional wind tunnel.</li> </ul>				
14. SUBJECT TERMS  Aeroelasticity, aeroservoelasticity			15. NUMBER OF PAGES 6	
			16. PRICE CODE	
17. SECURITY CLASSIFICATION OF REPORT unclassified	18. SECURITY CLASSIFICATION OF THIS PAGE unclassified	19. SECURITY CLASSIFICATION OF ABSTRACT unclassified	20. LIMITATION OF ABSTRACT UL	

20001117 111

NSN 7540-01-280-5500

Computer Generated

STANDARD FORM 298 (Rev 2-89)

Prescribed by ANSI Std Z39-18  
298-102

**FINAL REPORT ON AFOSR GRANT F49620-98-1-0131**

**Title: Aeroelasticity and Aeroservoelasticity of  
Uninhabited Long-Endurance Aircraft**

**Period: 1/1/98-3/31/99**

**Amount: \$60,000. -**

**Grant Monitor: Major Brian Sanders, Ph. D.  
AFOSR /NA  
801 N. Randolph Street, Room 732  
Arlington, VA 22203-1977  
Phone: (703) 696-7259**

**Principal  
Investigator: Professor Peretz P. Friedmann  
University of California  
48-121 Eng IV  
Mechanical and Aerospace Engineering  
Department, Box 951597  
Los Angeles, CA 90095-1597  
Phone 310-825-6041**

**DTIC QUALITY INSPECTED 4**

## **BACKGROUND AND OBJECTIVES**

This was a limited research grant initiated for a nine-month period, starting from January 1, 1998. Subsequently a six-month, no cost extension was granted ending on 3/31/1999. The proposal that served as the basis of the grant was aimed at the development of aeroelastic and aeroservoelastic models for uninhabited long endurance aircraft (ULA). However, due to the limited period of the funding it was decided, between the Principal Investigator (Professor P. Friedmann) and the grant monitor (Major Brian Sanders), to redirect this activity towards the development of aeroelastic and aeroservoelastic scaling laws of high altitude long endurance air-vehicles (HALE). The objectives of this modified activity are provided below.

### **Objectives and Technical Relevance**

The principal thrust of our activity was to conduct fundamental research on a new class of vehicles where geometrical and aerodynamic nonlinearities influence aeroelastic behavior. Due to the nine-month time limit it was decided to focus on the development of simple aeroelastic model for HALE type airvehicle capable of capturing the interactions between geometrically nonlinear flexible deformations and rigid body dynamics. An important part of this activity consisted of the collection of typical data for HALE type vehicles and its application to the development of ordering scheme suitable for this class of vehicles. Such ordering scheme is important for the development of reduced order models needed for aeroservoelastic studies. Another objective was the development of a procedure for coupling the structural dynamic model with the unsteady aerodynamic loads obtained from computational aerodynamics. The aeroelastic model will be used in combination with our two-pronged approach, to develop aeroelastic-scaling laws for this class of vehicles.

## **AEROELASTIC MODEL FOR A GENERIC HALE TYPE VEHICLE**

### **HALE Vehicles Fundamental Characteristics**

This class of vehicles has large aspect ratio flexible wings, which can be described by geometrically nonlinear, moderate deflection beam theory. The vehicles have a small fuselage (relative to conventional aircraft), and perform mild maneuvers. A typical vehicle in this category is shown in Fig. 1. These vehicles fly at high altitude (40,000-100,000 ft.) and operate at low Reynolds numbers (order of magnitude less than conventional aircraft). The unsteady aerodynamic environment of airfoils operating in this low Reynolds number range is characterized by flow with intermittent separation. There is a strong potential for interaction between flexible aircraft modes and rigid body vehicle modes, in these vehicles. The uninhabited nature of these vehicles implies high authority control systems, which can interact with vehicle flexibility. Additional control systems capable of modifying aero-structural interactions will also be present on this class of vehicles providing an opportunity for constructive uses of vehicle flexibility (or aeroelasticity) to enhance vehicle performance.

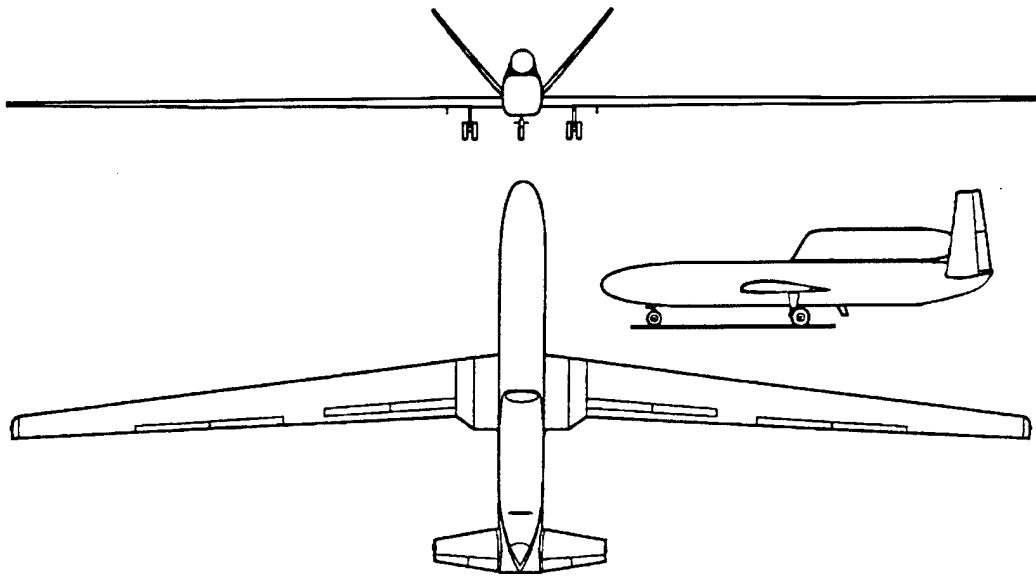

Figure 1. Typical HALE Vehicle (Similar to Global Hawk).

### **Basic Kinematic and Structural Assumptions**

Wings undergo moderate deflections, which imply small strains and moderate deflections. Wings built of composite materials, represented by anisotropic structural model, transverse shear and out of plane warping are included. Wings have moderate amounts of pre-twist and coupled chord-wise bending, out of plane of the wing bending, twist and axial deformation. A one dimensional, geometrically nonlinear beam theory is used to describe the span-wise structural dynamic behavior, and a separate linear two dimensional cross sectional analysis is used to generate the composite structural cross sectional constants

### **Structural Dynamic Model**

Based on these assumptions we have developed a finite element model for high aspect ratio composite wings undergoing moderate deflections. This model includes, shear, warping, and composite construction (material anisotropy). It is suitable for the modeling of wings having arbitrary multicell cross-sections. This finite element model consists of a 23 degree of freedom geometrically nonlinear beam type finite element that describes the spanwise properties of the wing, shown in Fig. 2. This is combined with a separate two dimensional finite element model consisting of quadrilateral element, that computes the

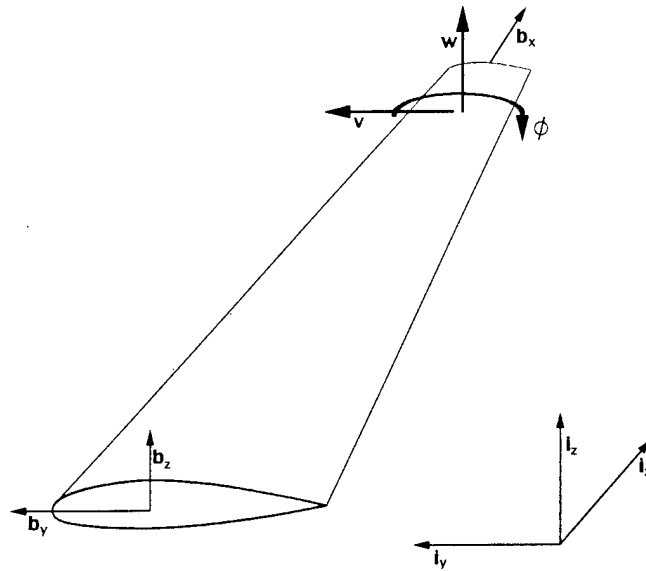

Figure 2. Typical large aspect ratio HALE wing.

cross-sectional constants of the composite multicell wing section. This analysis is described in detail in Ref. 1.

### Aeroelastic Model

The aeroelastic model is obtained by coupling this structural dynamic model with CFD based loads which are obtained from the unsteady solution of the Navier Stokes equations for a two dimensional airfoil. These loads are applied on the large aspect ration wing in a modified strip theory manner.

### ACCOMPLISHMENTS

The principal accomplishments during this time period are listed below:

- Collected typical data such as wing mass and stiffness distributions, geometric information and bending and torsional frequencies on HALE type vehicles such as Global Hawk, Darkstar, U-2, etc. and used it to develop an ordering scheme, utilizing non-dimensional parameters, for this class of vehicles.
- Developed simple structural dynamic/aeroelastic model for HALE type vehicles with isotropic wings undergoing moderate deflections in bending (normal to wing plane and chordwise), and torsion, and rigid body motion (plunge, pitch and fore and aft motion) using one mode for each elastic degree of freedom.
- Developed procedure for coupling the unsteady aerodynamic loads obtained from CFD with the structural dynamic model.

- Established fundamental aeroelastic scaling laws for testing of this class of vehicles, which operate at very low Reynolds numbers and high altitudes, in a conventional wind tunnel. Part of this material is included in a recent paper that will be published in October 2000 [Ref. 2].

## REFERENCES

1. Yuan, K. A., and Friedmann, P. P., "Aeroelasticity and Structural Optimization of Composite Helicopter Rotor Blades with Swept Tips," NASA CR 4665, 1995.
2. Friedmann, P. P. and Presente, E., "Active Control of Flutter in Subsonic Flow and Its Aeroelastic Scaling," to be published in the Journal of Guidance Control and Dynamics, Vol. 23, No. 5, September-October 2000.