

LOAN DOCUMENT

PHOTOGRAPH THIS SHEET

①

DTIC ACCESSION NUMBER

LEVEL

INVENTORY

2 Parts

Bioventing Pilot Test Work Plan

DOCUMENT IDENTIFICATION

Mar 94

DISTRIBUTION STATEMENT A
Approved for Public Release
Distribution Unlimited

DISTRIBUTION STATEMENT

ACCESSION BY	
NTIS	GRAM <input type="checkbox"/>
DTIC	TRAC <input type="checkbox"/>
UNANNOUNCED	
JUSTIFICATION	
BY	
DISTRIBUTION/	
AVAILABILITY CODES	
DISTRIBUTION	AVAILABILITY AND/OR SPECIAL
A-1	

DISTRIBUTION STAMP

DATE ACCESSIONED

DATE RETURNED

20001122 050

DATE RECEIVED IN DTIC

REGISTERED OR CERTIFIED NUMBER

PHOTOGRAPH THIS SHEET AND RETURN TO DTIC-FDAC

H
A
N
D
L
E

W
I
T
H

C
A
R
E

PART I

**Bioventing Pilot Test Work Plan Addendum
IRP Site 43, Building 1200 Former Diesel UST
Edwards AFB, California**

PART II

**Draft Bioventing Pilot Test Interim Results Report
IRP Site 43, Building 1200 Former Diesel UST
Edwards AFB, California**

Prepared For

**Air Force Center for Environmental Excellence
Brooks AFB, Texas**

and

Edwards AFB, California

ES

Engineering-Science, Inc.

March 1994

9404 Genesee Avenue, Suite 140
La Jolla, California 92037

ES ENGINEERING-SCIENCE

DEFENSE TECHNICAL INFORMATION CENTER REQUEST FOR SCIENTIFIC AND TECHNICAL REPORTS

Title AFCEE Collection

1. Report Availability (Please check one box)

- This report is available. Complete sections 2a - 2f.
- This report is not available. Complete section 3.

2a. Number of Copies Forwarded

1 each

2b. Forwarding Date

July/2000

2c. Distribution Statement (Please check ONE box)

DoD Directive 5230.24, "Distribution Statements on Technical Documents," 18 Mar 87, contains seven distribution statements, as described briefly below. Technical documents MUST be assigned a distribution statement.

- DISTRIBUTION STATEMENT A: Approved for public release. Distribution is unlimited.
- DISTRIBUTION STATEMENT B: Distribution authorized to U.S. Government Agencies only.
- DISTRIBUTION STATEMENT C: Distribution authorized to U.S. Government Agencies and their contractors.
- DISTRIBUTION STATEMENT D: Distribution authorized to U.S. Department of Defense (DoD) and U.S DoD contractors only.
- DISTRIBUTION STATEMENT E: Distribution authorized to U.S. Department of Defense (DoD) components only.
- DISTRIBUTION STATEMENT F: Further dissemination only as directed by the controlling DoD office indicated below or by higher authority.
- DISTRIBUTION STATEMENT X: Distribution authorized to U.S. Government agencies and private individuals or enterprises eligible to obtain export-controlled technical data in accordance with DoD Directive 5230.25, Withholding of Unclassified Technical Data from Public Disclosure, 6 Nov 84.

2d. Reason For the Above Distribution Statement (in accordance with DoD Directive 5230.24)

2e. Controlling Office

HQ AFCEE

2f. Date of Distribution Statement Determination

15 Nov 2000

3. This report is NOT forwarded for the following reasons. (Please check appropriate box)

- It was previously forwarded to DTIC on (date) and the AD number is
- It will be published at a later date. Enter approximate date if known.
- In accordance with the provisions of DoD Directive 3200.12, the requested document is not supplied because:

Print or Type Name

Laura Peña

Signature

Laura Peña

Telephone

210-536-1431

(For DTIC Use Only)

AQ Number MOI-01-0331

PART I

**BIOVENTING PILOT TEST WORK PLAN ADDENDUM
IRP SITE 43, BUILDING 1200 FORMER DIESEL UST
EDWARDS AFB, CALIFORNIA**

and

PART II

**DRAFT BIOVENTING PILOT TEST INTERIM RESULTS REPORT
IRP SITE 43, BUILDING 1200 FORMER DIESEL UST
EDWARDS AFB, CALIFORNIA**

Prepared for

Air Force Center for Environmental Excellence

Brooks AFB, Texas

and

Edwards AFB, California

March 1994

**Engineering-Science, Inc.
9404 Genesee Avenue, Suite 140
La Jolla, California 92037**

CONTENTS

PART I

BIOVENTING PILOT TEST WORK PLAN ADDENDUM FOR IRP SITE 43, BUILDING 1200 FORMER DIESEL UST EDWARDS AFB, CALIFORNIA

	Page
1.0 INTRODUCTION	I-1
2.0 SITE DESCRIPTION	I-1
2.1 Site Location and History	I-1
2.2 Site Geology	I-1
2.3 Site Contaminants	I-3
3.0 SITE-SPECIFIC ACTIVITIES	I-3
3.1 Site 43 Pilot Test Layout and Construction	I-3
3.2 Handling of Drill Cuttings	I-5
3.3 Soil and Soil Gas Sampling	I-5
3.4 Blower System	I-5
3.5 <i>In Situ</i> Respiration Test and Air Permeability Tests	I-5
3.6 Installation of an Extended (One-Year) Bioventing Pilot Test System	I-5
4.0 EXCEPTIONS TO PROTOCOL PROCEDURES	I-6
5.0 BASE SUPPORT REQUIREMENTS	I-6
6.0 PROJECT SCHEDULE	I-7
7.0 POINTS OF CONTACT	I-7
8.0 REFERENCES	I-8

FIGURES

Figure		Page
1.1	Location Map IRP Site 43, Building 1200 Former Diesel UST Site	I-2
1.2	Proposed Vent Well/Vapor Monitoring Point Locations IRP Site 43, Building 1200 Former Diesel UST Site	I-4

PART I

PART I

BIOVENTING PILOT TEST WORK PLAN ADDENDUM IRP SITE 43, BUILDING 1200 FORMER DIESEL UST EDWARDS AFB, CALIFORNIA

1.0 INTRODUCTION

This addendum modifies the existing "Bioventing Pilot Test Work Plan for Portions of Site 16 and Site 21, Edwards AFB, California", dated March 1993. This addendum provides site-specific information for the third bioventing pilot test to be conducted at Edwards AFB.

2.0 SITE DESCRIPTION

2.1 Site Location and History

Building 1200 is located between Wolfe Avenue to the northwest and the main taxi way to the southeast. Building 1200 houses the flightline manager operations facility. The Building 1200 former underground storage tank (UST) area is located to the west of Building 1200, within IRP Site 43. The former 165-gallon diesel UST was used to store fuel for an emergency generator located adjacent to Building 1200. The former diesel tank location, with respect to Building 1200, is shown in Figure 1.1.

Site information provided by Edwards AFB was limited to results of soil samples collected during tank removal. The information provided did not include: (1) the tank removal date, (2) the nature of backfill and native material, (3) the extent of contamination left in place, and (4) the soil boring logs and analytical results from site investigation borings for a nearby groundwater monitoring well.

During a recent site visit, standing water from lawn irrigation was observed. Instructions were given to base personnel to discontinue site irrigation at least two weeks prior to conducting the pilot test so that potentially saturated soils would have adequate time to dry out.

2.2 Site Geology

Soils at this site are believed to be similar to those at Site 16. Soils encountered during tank removal and sampling at Site 16 included silty sand, gravelly sand, and clay lenses. Bedrock was not encountered within the first 10.8 feet below ground surface (bgs). Weathered granite bedrock is anticipated at approximately 20 to 35 feet

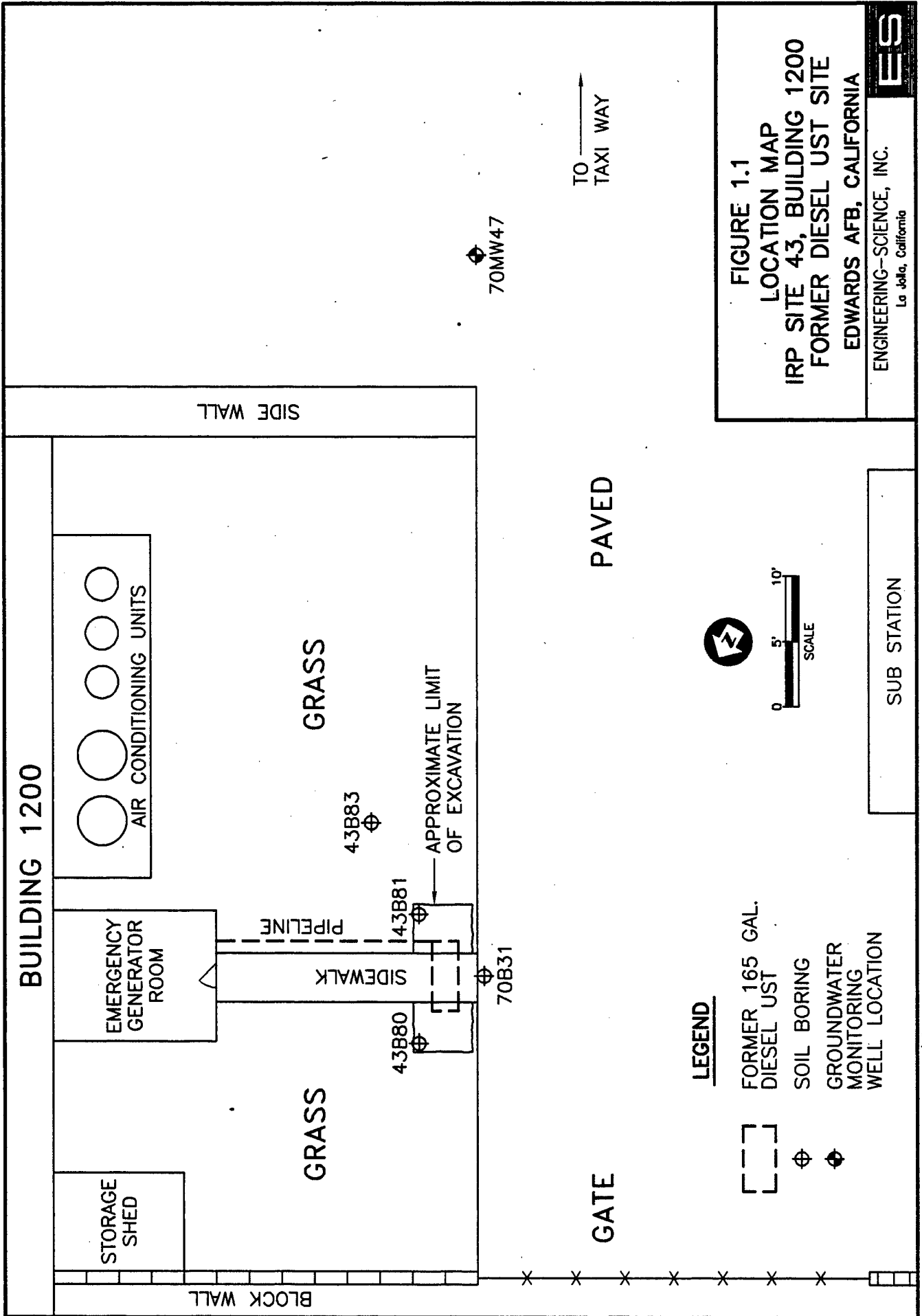

BUILDING 1200

STORAGE SHED

EMERGENCY GENERATOR ROOM

AIR CONDITIONING UNITS

BLOCK WALL

SIDE WALL

GRASS

GRASS

SIDEWALK

PIPELINE

43B80

43B83

43B81

APPROXIMATE LIMIT OF EXCAVATION

70B31

70MW47

GATE

PAVED

TO TAXI WAY

LEGEND

FORMER 165 GAL. DIESEL UST

SOIL BORING

GROUNDWATER MONITORING WELL LOCATION



SUB STATION

FIGURE 1.1

LOCATION MAP
IRP SITE 43, BUILDING 1200
FORMER DIESEL UST SITE

EDWARDS AFB, CALIFORNIA

ENGINEERING-SCIENCE, INC.

La Jolla, California



bgs at Site 43. Depth to groundwater is approximately 33 feet bgs based on recent measurements in well 70-MW-47.

2.3 Site Contaminants

The primary contaminants documented in soils at the site are petroleum hydrocarbons in the diesel range (TPH-d), as detected by EPA Method 8015 Modified for Diesel. Soil samples collected at two and six feet below the former tank bottom had the following hydrocarbon concentrations (Earth Technology, 1991):

Sample No.	Depth (ft bgs)	EPA 8015M for Diesel (mg/kg)	EPA 602 in (mg/kg)			
			Benzene	Toluene	Ethyl Benzene	Xylenes
S1	6.0	22,620	ND	1.19	3.333	20.6
S2	10.8	277.8	ND	ND	ND	ND

Sample analytical results from four nearby soil borings and a groundwater monitoring well were not available at the time of this writing.

3.0 SITE-SPECIFIC ACTIVITIES

Site specific activities will include: (1) siting and construction of a central air injection well (VW) and three vapor monitoring points (MPs); (2) an air permeability test, (3) an *in situ* respiration test; and (4) the implementation of an extended (one-year) bioventing pilot test.

3.1 Site 43 Pilot Test Layout and Construction

A general description of criteria used for siting a central VW and vapor MPs are included in the protocol document (Hinchee et al., 1992). Figure 1.2 illustrates the proposed locations of the central VW and MPs within Site 43. The final locations of the VW and MPs may vary slightly from the proposed locations if significant fuel contamination is not observed in the boring for the central VW. Soils in this area are expected to be oxygen-depleted (<2 percent O₂) due to high hydrocarbon levels, and increased biological activity should be stimulated by oxygen-rich soil gas injection during pilot test operations.

Due to the relatively shallow depth of contamination expected at the test area, and the experience that ES has had with bioventing in this soil type, the potential radius of venting influence around the central VW is expected to be 20 to 40 feet. Three vapor MPs (MPA, MPB, and MPC) will be located within a 20-foot radial distance of the central VW. A background MP will not be installed at this site. Background levels of oxygen and carbon dioxide obtained during the Site 16 pilot test will be used to determine if inorganic or natural carbon sources are contributing to oxygen uptake during the *in situ* respiration test at Site 43, since soil types are expected to be similar.

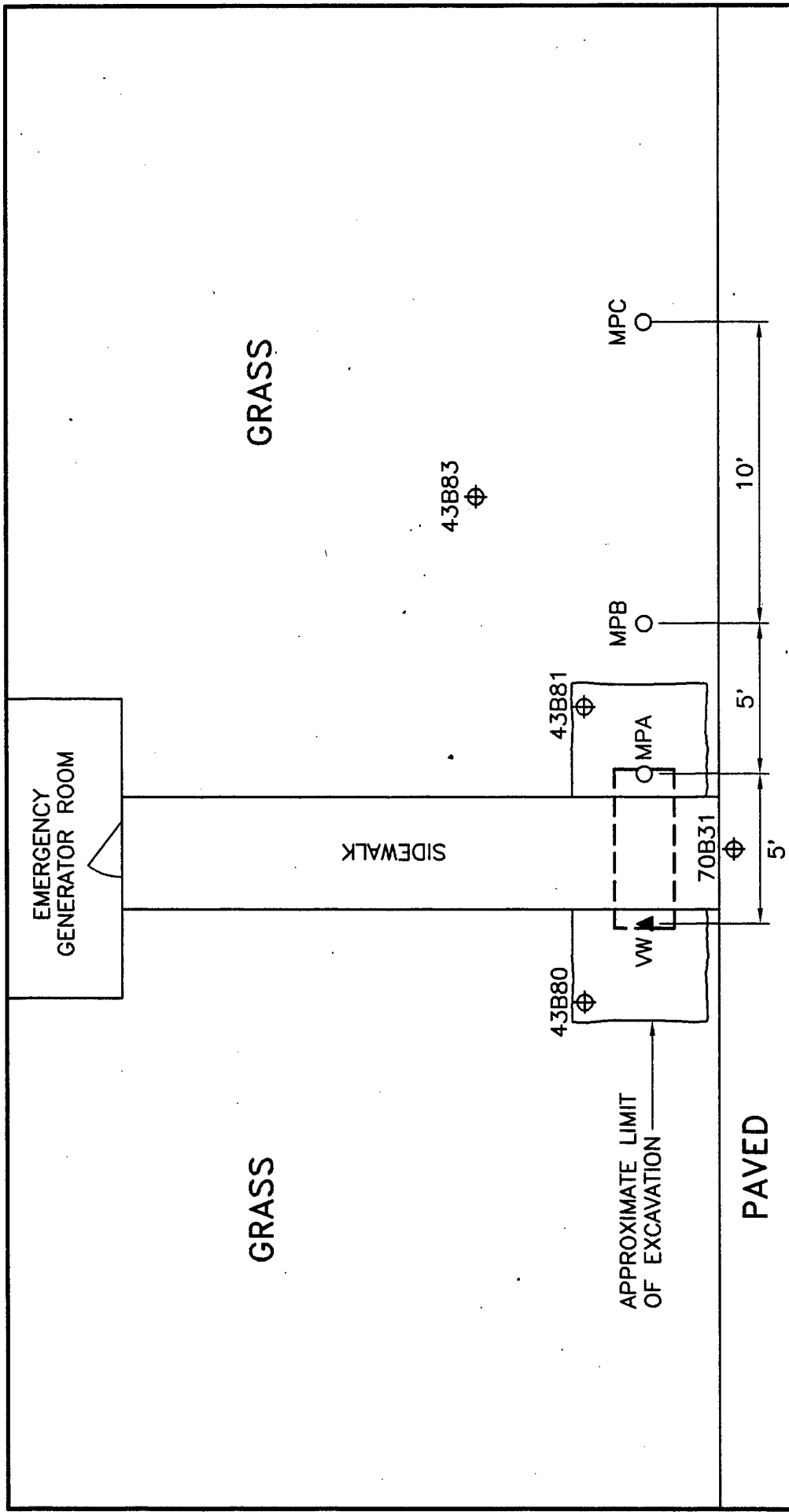
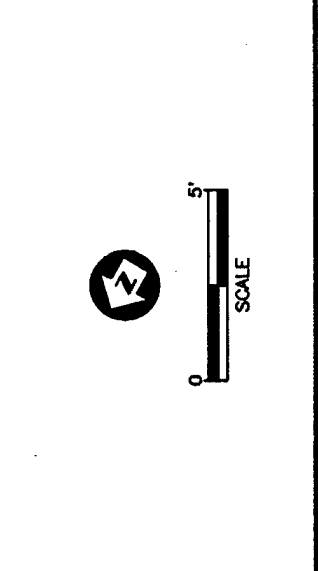

FIGURE 1.2
PROPOSED VENT WELL/VAPOR
MONITORING POINT LOCATIONS
IRP SITE 43, BUILDING 1200
FORMER DIESEL UST SITE
EDWARDS AFB, CALIFORNIA
ENGINEERING-SCIENCE, INC.
 La Jolla, California



LEGEND	
[---]	FORMER 165 GAL. DIESEL UST
⊕	SOIL BORING
▲	VENT WELL
○	MONITORING POINT

Additional details on *in situ* respiration test procedures are found in Section 5.7 of the protocol document (Hinchee et al., 1992).

The VW and MPs will be constructed as described in Section 3.1, and as shown in Figures 3.2 and 3.3 of the March 1993 Bioventing Pilot Test Work Plan. It should be noted that the VW and MPs will be constructed above the groundwater table. Boreholes advanced into the groundwater will be backfilled to the groundwater table.

3.2 Handling of Drill Cuttings

Drill cuttings from all borings will be screened in the field with a total hydrocarbon vapor analyzer (see protocol document, Section 4.5.2). Cuttings with field evidence of petroleum contamination (e.g., discoloration, petroleum odor, above-background PID readings) will be collected in U.S. Department of Transportation (DOT) approved containers. These containers will be labeled and placed in the Edwards AFB hazardous material storage area. These drill cuttings will become the responsibility of Edwards AFB and will be analyzed, handled, and disposed of by Edwards AFB in accordance with the current procedures for on-going remedial investigations. Cuttings without field evidence of petroleum contamination will be segregated from contaminated soils, containerized, and labeled. These cuttings will be transported to a location designated by the base point of contact.

3.3 Soil and Soil Gas Sampling

Soil and soil gas sampling procedures will be followed, as described in the March 1993 Bioventing Pilot Test Work Plan, with the exception of soil sample shipment to Pace Analytical Laboratories (formerly ES Laboratory) in Novato, California.

3.4 Blower System

A 1-horsepower regenerative blower, capable of injecting up to 30 standard cubic feet per minute (scfm) at 40 inches of water, will be used to conduct the initial air permeability test and *in situ* respiration test. A schematic of a typical air injection system used for pilot testing is shown in Figure 3.7 of the March 1993 Bioventing Pilot Test Work Plan. The maximum power requirement anticipated for this pilot test is a 230-volt, single-phase, 30-amp service. Additional details on power supply requirements are described in Section 5.0, Base Support Requirements.

3.5 *In Situ* Respiration Test and Air Permeability Tests

In situ respiration and air permeability tests, as described in Sections 3.6 and 3.7 of the March 1993 Bioventing Pilot Test Work Plan, will be conducted at Site 43.

3.6 Installation of an Extended (One-Year) Bioventing Pilot Test System

A bioventing system for the extended (one-year) pilot test will be installed at the test site following the initial pilot test. It is requested that the base provide a power pole with a 230-volt, single-phase, 30-amp breaker box with one 230-volt receptacle and two 110-volt receptacles. Depending on the availability of a base electrician, a base electrician or a licensed electrician subcontracted to ES will assist in the final wiring of the blower to the breaker box. A 1 horsepower regenerative blower will be housed in a small, prefabricated shed to provide protection from the weather. The shed will be painted "Marble Cream" as requested by the base. The shed will be located next to

Building 1200. The blower will be connected to the VW using a 2-inch diameter PVC pipe buried in a trench approximately 6 inches bgs.

The system will be operated for one year. After six months, ES personnel will conduct an *in situ* respiration test to monitor the long-term performance of this bioventing system. Weekly system checks will be performed by Edwards AFB personnel. If required, any major maintenance of the blower unit will be performed by ES personnel. Detailed blower system information and a maintenance schedule will be included in the operation and maintenance (O&M) manual provided to the base. More detailed information regarding the extended pilot test procedures can be found in the protocol document (Hinchee et al., 1992).

4.0 EXCEPTIONS TO PROTOCOL PROCEDURES

The procedures that will be used to construct the VW and MPs, and to measure soil permeability to air and *in situ* respiration rates, are described in Sections 4 and 5, respectively, of the protocol document (Hinchee et al., 1992). No exceptions to the protocol document procedures are anticipated.

5.0 BASE SUPPORT REQUIREMENTS

The following base support is needed prior to arrival of the drilling subcontractor and the ES pilot test team:

- Obtaining a base excavation permit.
- Confirmation of an available power source and installing a 230-volt, 30-amp, single-phase breaker box with one 230-volt receptacle and two 110-volt receptacles located within 50 feet of the VW.
- Provision of any paperwork required to obtain gate passes and security badges for approximately three ES employees, two drillers, and an electrician (if a base electrician is not available). Vehicle passes will be needed for one truck and trailer, and a drill rig. ES will provide, in advance, social security numbers of the field team and drillers, as well as license plate numbers of vehicles to be used on the flightline.
- Provision of keys to the on-site groundwater monitoring wells.

During initial testing, the following base support is needed:

- Twelve square feet of desk space and a telephone in a building located as close to the site as practical.
- Use of a facsimile machine for transmitting 15 to 20 pages of test results.
- A decontamination pad where the driller can clean the augers between borings.
- Acceptance of responsibility for drill cuttings and decontamination water generated from VW and MP borings, including drum sampling to determine hazardous waste status. (If ES transfers custody of drums to another contractor working on the base, assistance in arranging this transfer will also be needed.)

During the one-year extended pilot tests, base personnel will be required to perform the following activities:

- Check the blower system once per week to ensure that it is operating and to record the air injection pressure and temperature. ES will provide a brief training session for this procedure and a maintenance procedures manual with data collection sheets.
- If the blower stops working, notify: Mr. Larry Dudus of ES San Diego at (619) 453-9650, Mr. Chris Pluhar of ES Pasadena at (818) 585-6324, or Mr. Sam Taffinder of AFCEE at (800) 821-4528, ext. 230.
- Arrange site access for an ES technician to conduct *in situ* respiration tests approximately six months and one year after the initial pilot test.

6.0 PROJECT SCHEDULE

The following schedule is contingent upon timely approval of this pilot test work plan.

<u>Event</u>	<u>Date</u>
Draft Test Work Plan to AFCEE/Edwards AFB	14 June 1993
Approval to Proceed	2 September 1993
Begin Initial Pilot Test	8 September 1993
Final Test Work Plan/Interim Results Report	29 February 1994
Second Respiration Test	March 1994
Final Respiration Test and Soil Sampling	September 1994

7.0 POINTS OF CONTACT

Mr. Steve Daneke
70 North Wolfe Avenue
Edwards AFB, CA 93524-6225
(805) 277-1401

Major Ross Miller/Mr. Sam Taffinder
AFCEE/EST
2504 "D" Drive, Suite 3
Brooks AFB, TX 78235-5103
(800) 821-4528, ext. 282, 230

Mr. Larry Dudus
Engineering-Science, Inc.
9404 Genesee Avenue, Suite 140
La Jolla, CA 92307

(619) 453-9650
FAX (619) 453-9652

Mr. Doug Downey
Engineering-Science, Inc.
1700 Broadway, Suite 900
Denver, CO 80290
(303) 831-8100
FAX (303) 831-8208

8.0 REFERENCES

- Engineering-Science, Inc. *Field Sampling Plan for AFCEE Bioventing*. Denver, Colorado. 1992.
- Hinchee, R.E., Ong, S.K., Miller, R.N., Downey, D.C., and Frandt, R. *Test Plan and Technical Protocol for a Field Treatability Test for Bioventing*. January 1992.
- The Earth Technology Corporation. *Underground Tank Removal Soil Sampling Report Field Note Work Sheet and Soil Sample Analysis Table*. 1991.

PART II

CONTENTS

PART II

DRAFT BIOVENTING PILOT TEST INTERIM RESULTS REPORT IRP SITE 43, BUILDING 1200 FORMER DIESEL UST EDWARDS AFB, CALIFORNIA

	Page
1.0 INTRODUCTION	II-1
2.0 IRP SITE 43, BUILDING 1200 FORMER DIESEL UST	II-1
2.1 Pilot Test Design and Construction	II-1
2.1.1 Air Injection Vent Well	II-1
2.1.2 Monitoring Point	II-5
2.1.3 Blower Unit	II-5
2.2 Soil and Soil Gas Sampling Results	II-5
2.2.1 Soil Sampling Results	II-5
2.2.2 Soil Gas Sampling Results	II-8
2.3 Pilot Test Results	II-8
2.3.1 Exceptions to Test Protocol Procedures	II-8
2.3.2 Initial Soil Gas Chemistry	II-10
2.3.3 <i>In Situ</i> Respiration Rates	II-10
2.3.4 Air Permeability	II-10
2.3.5 Oxygen Influence	II-10
2.3.6 Potential Air Emissions	II-14
2.4 Recommendations	II-14
3.0 REFERENCES	II-14

APPENDIX A

Operation and Maintenance Manual

APPENDIX B

Geologic Boring Logs and Chain of Custody Forms

FIGURES

Figure		Page
2.1	Record Drawing Vent Well/Vapor Monitoring Point Locations IRP Site 43, Building 1200 Former Diesel UST Site	II-2
2.2	Geologic Cross-Section A-A' IRP Site 43, Building 1200 Former Diesel UST Site	II-3
2.3	Record Drawing Air Injection Vent Well Construction Details IRP Site 43, Building 1200 Former Diesel UST Site	II-4
2.4	Record Drawing Monitoring Point Construction Details IRP Site 43, Building 1200 Former Diesel UST Site	II-6
2.5	Record Drawing Blower System for Air Injection IRP Site 43, Building 1200 Former Diesel UST Site	II-7
2.6	Respiration Test, ED3-VW IRP Site 43, Building 1200 Former Diesel UST Site	II-13

TABLES

Table		Page
2.1	Soil and Soil Gas Laboratory Analytical Results IRP Site 43, Building 1200 Former Diesel UST Site	II-9
2.2	Initial Soil Gas Chemistry IRP Site 43, Building 1200 Former Diesel UST Site	II-11
2.3	Oxygen Utilization Rates IRP Site 43, Building 1200 Former Diesel UST Site	II-12
2.4	Influence of Air Injection Vent Well on Monitoring Point Oxygen Levels, IRP Site 43, Building 1200 Former Diesel UST Site	II-15

PART II

DRAFT BIOVENTING PILOT TEST INTERIM RESULTS REPORT IRP SITE 43, BUILDING 1200 FORMER DIESEL UST EDWARDS AFB, CALIFORNIA

1.0 INTRODUCTION

The purpose of this Part II report is to describe the results of the initial pilot test at the Building 1200 former diesel underground storage tank (UST) at IRP Site 43, and to make specific recommendations for extended testing, which will determine the long-term impact of bioventing on site contaminants. An initial bioventing pilot test was completed at the Building 1200 former diesel UST site during 7 September through 15 September 1993. Descriptions of the history, geology, and contaminants at the site are contained in Part I, the Bioventing Pilot Test Work Plan Addendum.

While the initial pilot test was being conducted at the Building 1200 former diesel UST site, the six-month respiration test was performed at IRP Sites 16 and 21. Respiration test data from these two sites was sent to the Air Force Center for Environmental Excellence (AFCEE). A copy was also forwarded to Edwards AFB.

2.0 IRP SITE 43, BUILDING 1200 FORMER DIESEL UST

2.1 Pilot Test Design and Construction

Installation of an air injection vent well (VW) and a vapor monitoring point (MP) at the Building 1200 former diesel UST site (designated ED3) was completed on 8 September 1993. Drilling services were provided by Tonto Environmental Drilling of Fontana, California. Well installation and soil sampling were directed by Mr. Chris Pluhar and Mr. Tom Blaney, geologists with Engineering-Science, Inc. The following sections describe the final design and installation of the bioventing pilot test system at this site.

One VW (ED3-VW), one MP (ED3-MPA), and a blower unit were installed at the site. Figures 2.1 and 2.2, respectively, depict the location of, and a hydrogeologic cross section for, the VW and MP completed at the site.

2.1.1 Air Injection Vent Well

The air injection VW was installed following procedures described in the Air Force Center for Environmental Excellence (AFCEE) bioventing protocol document (Hinchee et al., 1992). Figure 2.3 shows construction details for ED3-VW.

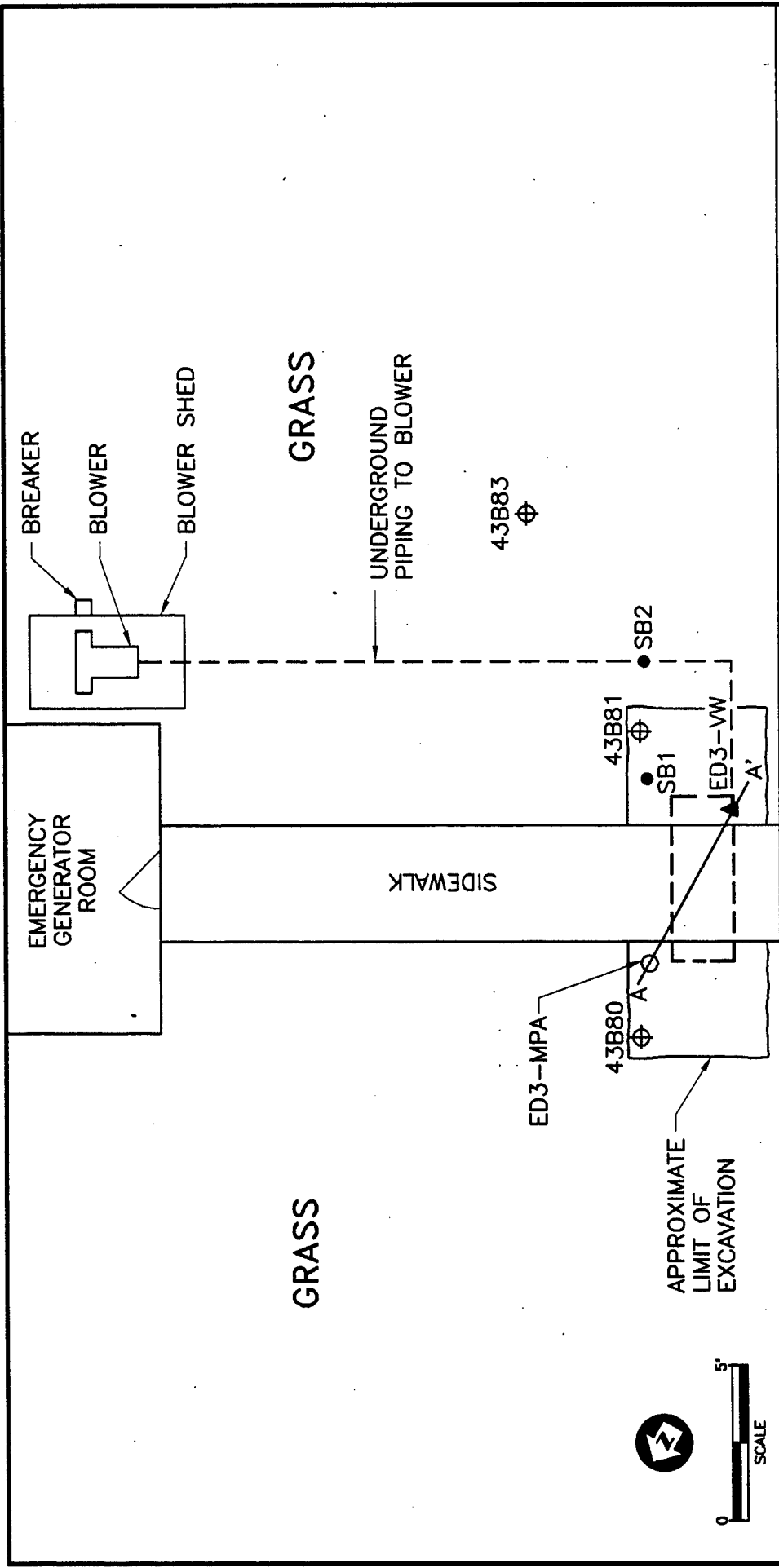

FIGURE 2.1
RECORD DRAWING VENT WELL/VAPOR
MONITORING POINT LOCATIONS
IRP SITE 43, BUILDING 1200
FORMER DIESEL UST SITE
EDWARDS AFB, CALIFORNIA
ENGINEERING-SCIENCE, INC.
 La Jolla, California

LEGEND	
[---]	FORMER 165 GAL. DIESEL UST
⊕	PREVIOUS SOIL BORING
▲	VENT WELL
○	MONITORING POINT
●	SOIL BORING
A-A'	GEOLOGIC CROSS SECTION LOCATION

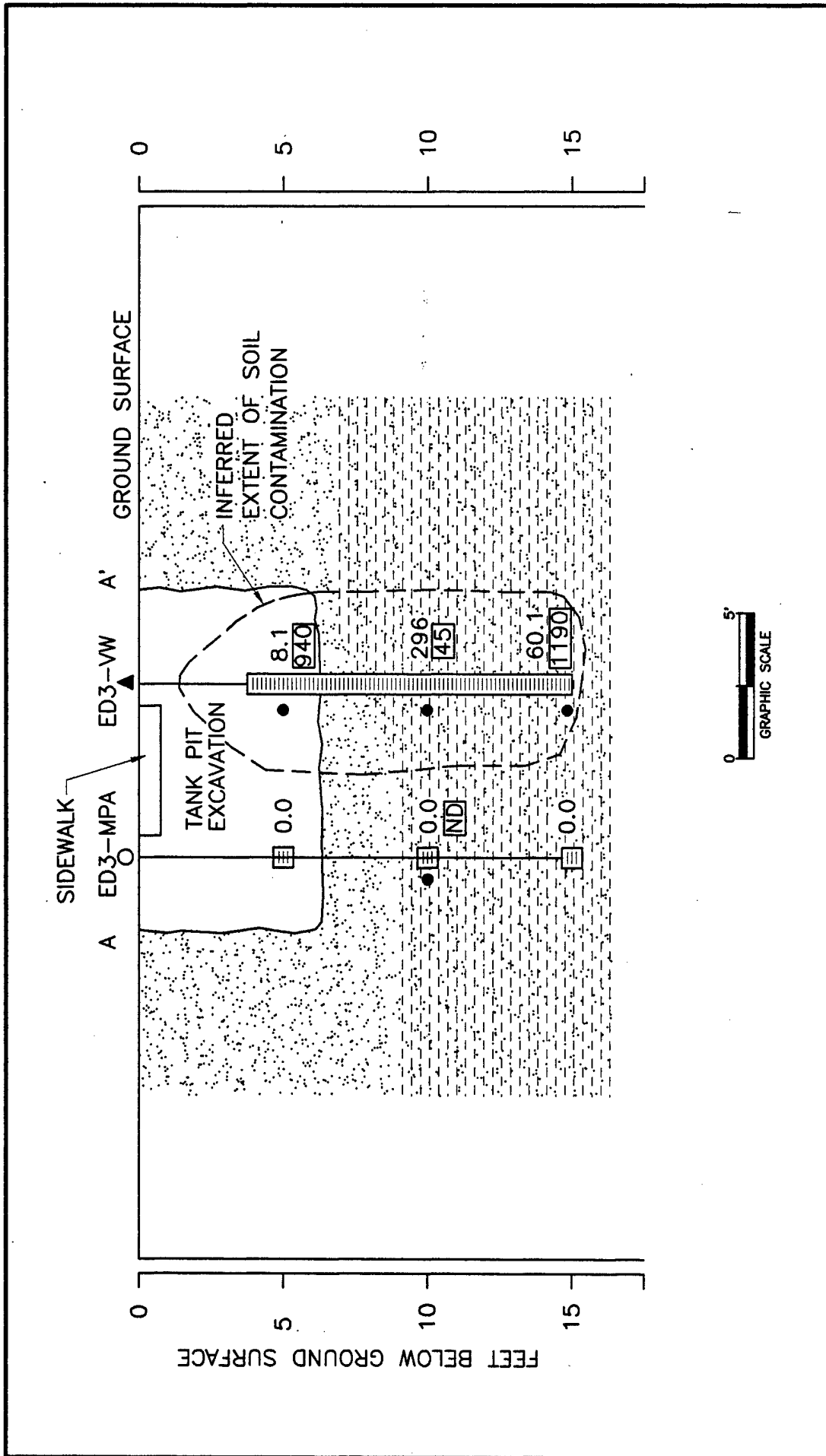

FIGURE 2.2
GEOLOGIC CROSS-SECTION A-A'
IRP SITE 43, BUILDING 1200
FORMER DIESEL UST SITE
EDWARDS AFB, CALIFORNIA
ENGINEERING-SCIENCE, INC.
 La Jolla, California

LEGEND

	0.0	FIELD PID READINGS (PPMV)	NOT DETECTED
	ND	LABORATORY RESULTS FOR TOTAL RECOVERABLE PETROLEUM HYDROCARBONS BY EPA 418.1 (MG/KG)	VENT WELL SCREENED INTERVAL

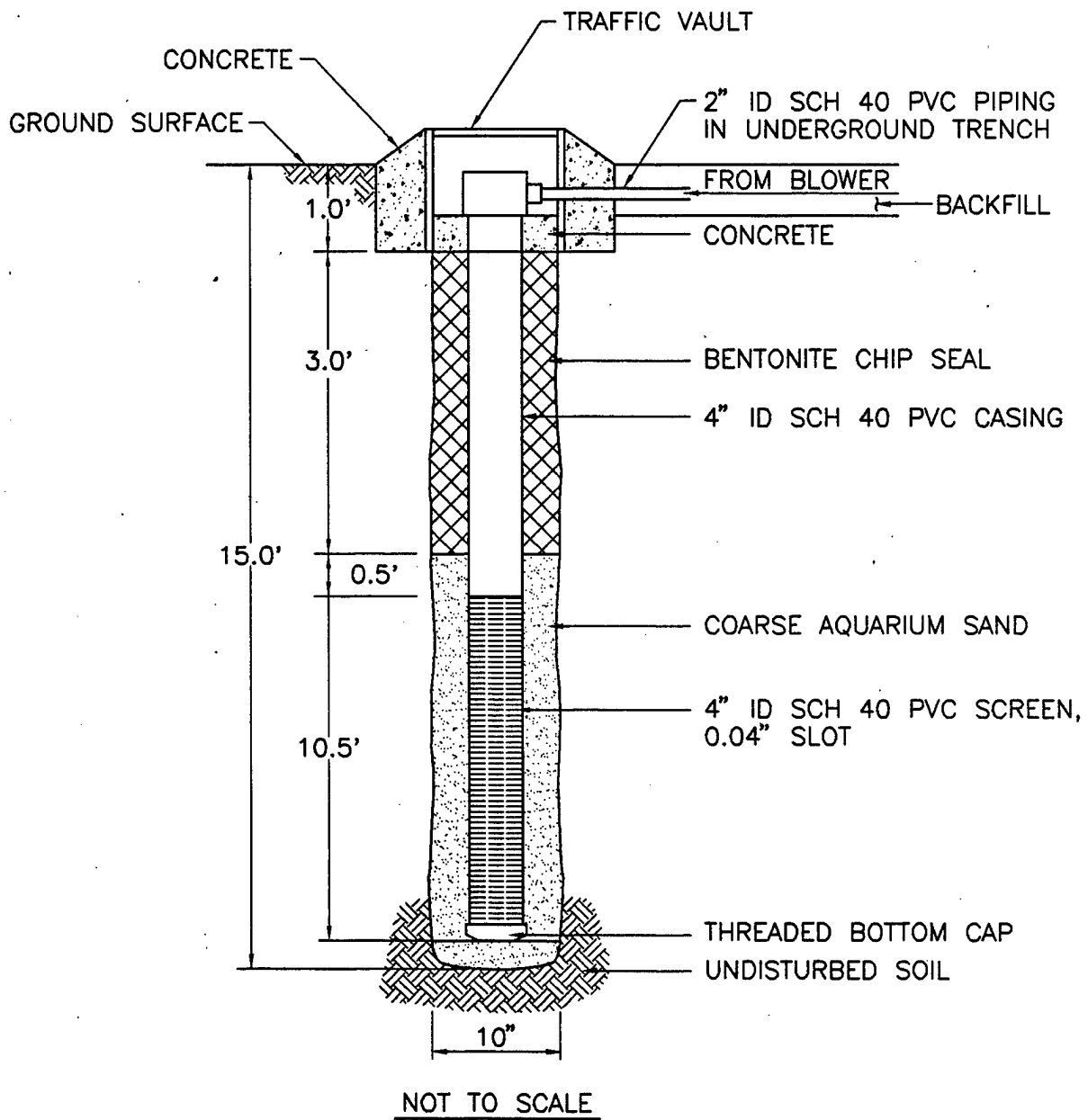

FIGURE 2.3
RECORD DRAWING
AIR INJECTION VENT WELL
CONSTRUCTION DETAILS
IRP SITE 43, BUILDING 1200
FORMER DIESEL UST SITE
EDWARDS AFB, CALIFORNIA

ENGINEERING-SCIENCE, INC.
 La Jolla, California

ES

The VW was installed through the former tank bed in hydrocarbon-contaminated soil. The VW was constructed using 4-inch diameter, Schedule 40 polyvinyl chloride (PVC) casing, with 10 feet of 0.02 inch slotted PVC screen installed from 4.5 to 14.5 feet below ground surface (bgs) and a PVC end cap from 14.5 to 15 feet bgs. The annular space between the well casing and borehole was filled with coarse aquarium silica sand from 15 feet bgs to just above the well screen. Approximately three feet of bentonite chips were placed above the sand and hydrated in place. The top of the well was completed with a flush-mounted metal well vault set in a 2.5 x 2.5 x .5 foot concrete pad. The well casing was finished with a tee fitting, approximately six inches bgs. This fitting is connected to a 2-inch diameter, Schedule 40 PVC pipe, which runs underground for about 20 feet to the blower. The PVC pipe connects to the blower piping at a galvanized steel union located inside the blower shed.

2.1.2 Monitoring Point

The MP screens were installed at 5, 10, and 15 foot depths. The MP was constructed as shown in Figures 2.2 and 2.4. The MP monitoring interval was constructed using a 6-inch section of 1-inch diameter 0.02-inch slotted PVC well screen, and a 0.25-inch diameter Schedule 80 PVC riser pipe extending to the ground surface. At the top of each riser, a ball valve and a 3/16-inch hose barb were installed. The top of the MP was completed with a flush-mounted metal well vault set in a concrete base. Thermocouples were installed at the five and 15 foot depths to measure soil temperature variations.

2.1.3 Blower Unit

A portable 1/6-horsepower Gast® rotary vane blower unit was used for the initial pilot test. For the extended pilot test, a 1-horsepower Gast® regenerative blower was installed in a small shed located adjacent to Building 1200, next to the emergency generator and the building's air conditioning units. The fixed unit is energized by a 115-volt, single-phase, 20-amp power line from within Building 1200. The configuration, instrumentation, and specifications for this blower system are shown in Figure 2.5. The blower is currently injecting air at a flow rate of approximately 40 cubic feet per minute (cfm) for the extended pilot test. After blower installation and start-up, ES engineers provided an operation and maintenance (O&M) manual, including maintenance instructions, equipment specifications, and monitoring forms, to base personnel. A copy of the O&M manual is provided in Appendix A.

2.2 Soil and Soil Gas Sampling Results

2.2.1 Soil Sampling Results

Soils at this site consist primarily of sand and silty sand. Groundwater was not encountered during drilling operations, which reached a total depth of 15 feet bgs. Groundwater in a nearby well was encountered at 31.4 feet bgs at the time of drilling.

During drilling, the areal extent of contamination was found to be very small. Several borings were drilled in search of contamination. Two of these borings, SB1 and SB2, were subsequently abandoned and backfilled (Figure 2.1). SB2 was abandoned due to the absence of contamination. SB1, although contaminated, was abandoned due to its close proximity (five feet) to the much more contaminated VW.

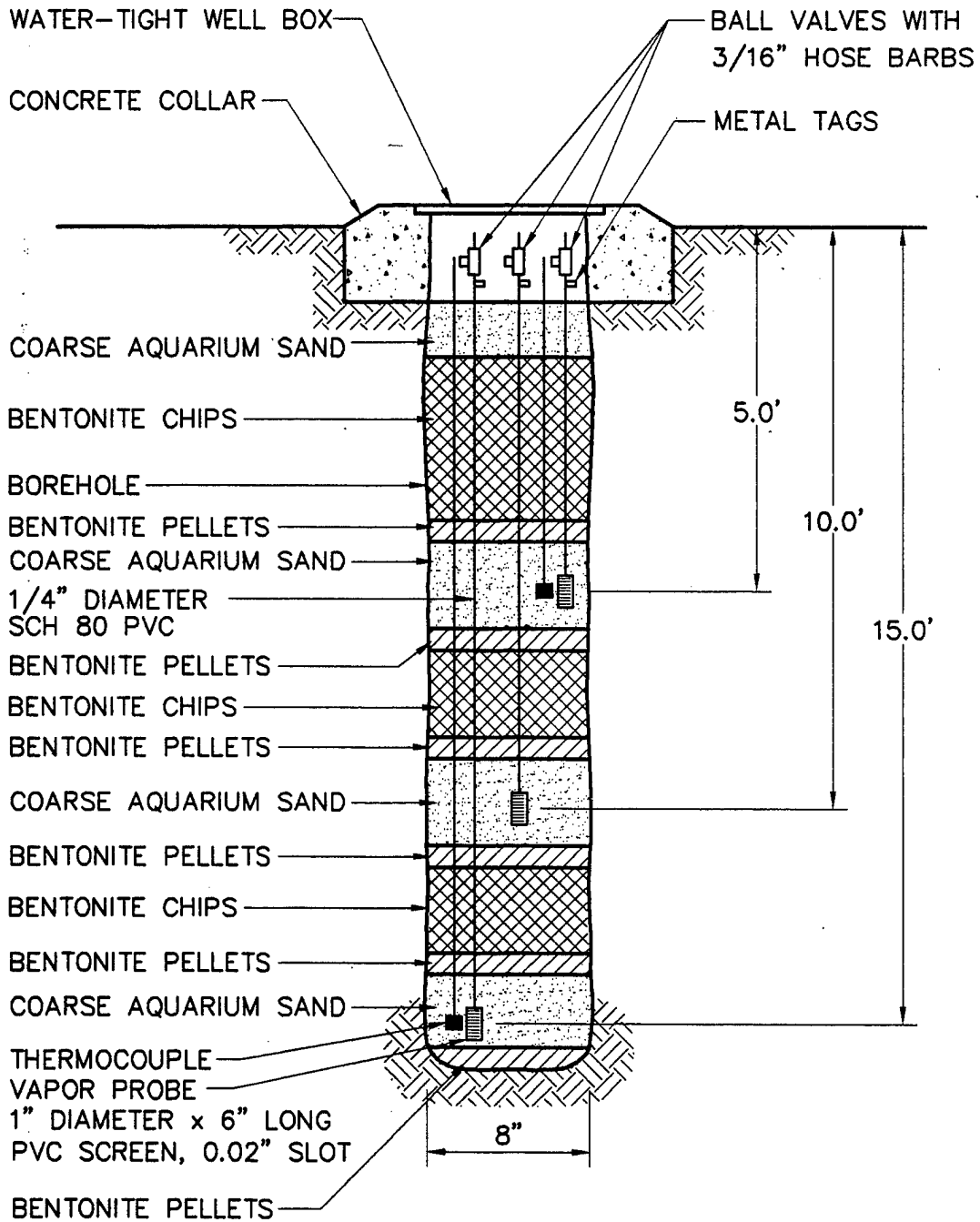
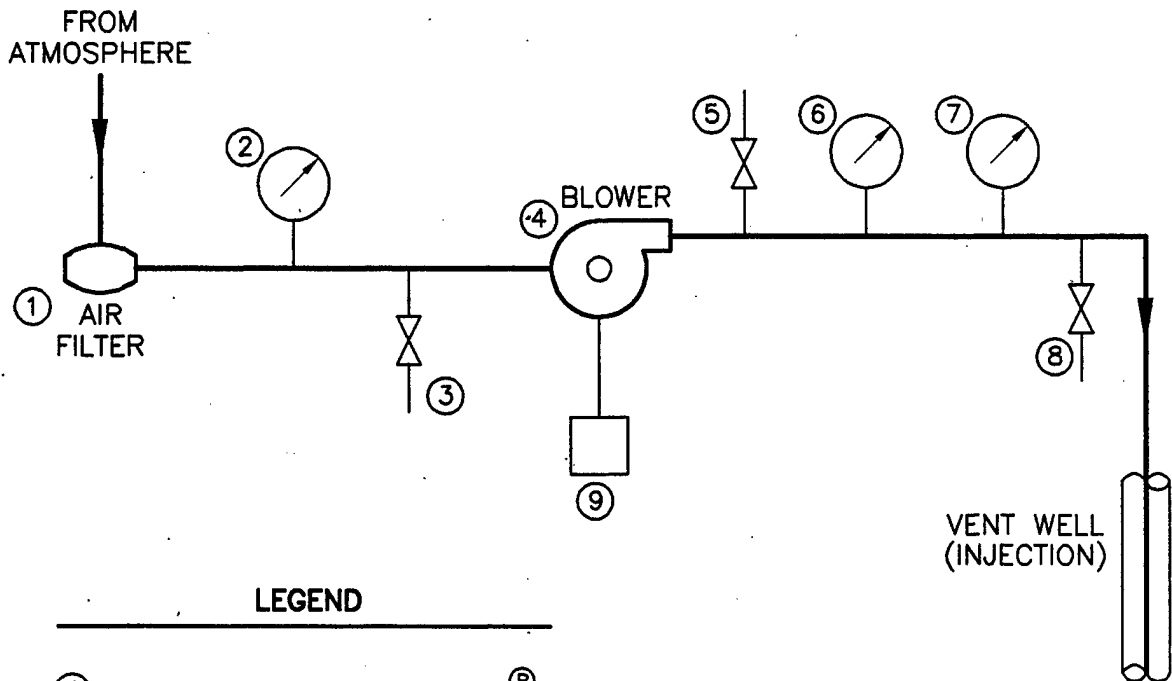

FIGURE 2.4
RECORD DRAWING
MONITORING POINT
CONSTRUCTION DETAILS
IRP SITE 43, BUILDING 1200
FORMER DIESEL UST SITE
EDWARDS AFB, CALIFORNIA

ENGINEERING-SCIENCE, INC.
 La Jolla, California





LEGEND

- ① INLET AIR FILTER - GAST[®] AJ126D
- ② VACUUM GAUGE (-60-0 IN H₂O) - GAST[®] AJ497
- ③ VACUUM RELIEF VALVE SET TO RELEASE AT 30 IN H₂O VACUUM
GAST[®] AG258
- ④ BLOWER - GAST[®] 1HP R4110N-50
- ⑤ MANUAL PRESSURE RELIEF (BLEED) VALVE - 1 1/2" GATE
- ⑥ PRESSURE GAUGE (0-60 IN H₂O) - GAST[®] AJ496
- ⑦ TEMPERATURE GAUGE (0°-250° F) - ASHCROFT[®] 30EI 60R 025 0°/250°F
- ⑧ PRESSURE RELIEF VALVE, SET TO RELEASE AT 30 IN H₂O PRESSURE
GAST[®] AG258
- ⑨ BREAKER BOX - 20 AMP

FIGURE 2.5

**RECORD DRAWING
BLOWER SYSTEM
FOR AIR INJECTION
IRP SITE 43, BUILDING 1200
FORMER DIESEL UST SITE
EDWARDS AFB, CALIFORNIA**

ENGINEERING-SCIENCE, INC.
La Jolla, California



The VW and SB1 showed evidence of contamination, whereas MPA and SB2, each seven feet from the vent well, did not show evidence of contamination (see Table 2.1 and Figure 2.2). Hydrocarbon odor and staining of the soil was encountered from two to 15 feet bgs in the VW, and from six to nine feet bgs in SB1. Field measurements using a photoionization detector (PID) indicated volatile hydrocarbons in both of these borings as well.

More detailed hydrogeologic information regarding the site can be found in the hydrogeologic cross section (Figure 2.2) and the geologic boring logs (Appendix B).

Soil samples for laboratory analysis were collected using an 18-inch split-spoon sampler with 2-inch diameter brass liners. Soil samples were collected from ED3-VW at 5, 10, and 15 feet bgs and from ED3-MPA at 10 feet bgs.

Soil samples were shipped via Federal Express® to Pace Laboratory in Novato, California, for chemical and physical analysis. Soil samples were analyzed for total recoverable petroleum hydrocarbons (TRPH); benzene, toluene, ethylbenzene, and xylenes (BTEX); iron; alkalinity; Total Kjeldahl Nitrogen (TKN); moisture content; and grain-size distribution. The results of these analyses are provided in Table 2.1. Chain-of-custody forms are provided in Appendix B.

2.2.2 Soil Gas Sampling Results

Soil gas samples were collected from ED3-VW and ED3-MPA at 15 feet. Soil gas samples were collected using 3-liter Tedlar® bags and a vacuum chamber. After the samples were collected in the Tedlar® bags, they were transferred to 1-liter SUMMA® canisters and shipped to the laboratory.

Soil gas samples were shipped via Federal Express® to Air Toxics, Inc., in Rancho Cordova, California, for total volatile hydrocarbon (TVH) and BTEX analysis. The TVH analyses were referenced to jet fuel (Molecular Weight = 156) since there is no suitable analysis for diesel. The results of these analyses are provided in Table 2.1. Chain-of-custody forms are provided in Appendix B.

2.3 Pilot Test Results

2.3.1 Exceptions to Test Protocol Procedures

Procedures described in the protocol document and the site-specific work plan (Part I) were used to complete the pilot test at this site.

Several exceptions were made to the protocol document as a result of limited contamination. During drilling and installation of the VW and MP, four borings were drilled in search of contamination. Two of these were later abandoned and backfilled with bentonite. The VW and MPA were installed in the remaining boreholes. Only one monitoring point, MPA, was installed instead of the three called for in the workplan and protocol document due to the limited area of contamination.

The respiration test was run in the VW because MPA was outside the apparent zone of contamination. In addition, a small (1 cfm) blower, instead of a blower with a larger flow rate, was used to run the air permeability test.

Table 2.1

**Soil and Soil Gas Laboratory Analytical Results
IRP Site 43, Building 1200 Former Diesel UST
Edwards AFB, California**

Analyte (Units) ^a	Sample Location - Depth (Feet Below Ground Surface)			
	ED3-MPA-15	ED3-VW		
Soil Gas Hydrocarbons				
TVH ^b (ppmv)	76	690		
Benzene (ppmv)	ND(0.002)	ND(0.023)		
Toluene (ppmv)	0.006	ND(0.023)		
Ethylbenzene (ppmv)	ND(0.002)	0.18		
Xylenes (ppmv)	ND(0.002)	0.95		
Soil Hydrocarbons				
TRPH ^c (mg/kg)	ED3-MPA-10	ED3-VW-5	ED3-VW-10	ED3-VW-15
	ND(5.4)	940	45	1190
Benzene (mg/kg)	ND(0.0006)	ND(0.29)	ND(0.0006)	ND(0.27)
Toluene (mg/kg)	ND(0.0006)	ND(0.29)	ND(0.0006)	ND(0.27)
Ethylbenzene (mg/kg)	ND(0.0006)	0.37	ND(0.0006)	ND(0.27)
Xylenes (mg/kg)	ND(0.0006)	1.6	ND(0.0008)	1.1
Soil Inorganics				
Iron (mg/kg)	12,400	14,300	NA	NA
Alkalinity (mg/kg as Ca CO ₃ ^d)	230	770	NA	NA
pH (Units)	9.3	8.5	NA	NA
TKN ^e (mg/kg)	27	280	NA	NA
Phosphates (mg/kg)	150	560	NA	NA
Soil Physical Parameters				
Moisture (% wt)	7.4	13	8.2	9.0
Gravel (%)	5.8	2.0	NA	NA
Sand (%)	79.3	65.0	NA	NA
Silt (%)	6.3	15.9	NA	NA
Clay (%)	8.6	17.1	NA	NA

^a ppmv = Parts Per Million, Volume Per Volume; mg/kg = Milligrams Per Kilogram

^b TVH = Total Volatile Hydrocarbons.

^c TRPH = Total Recoverable Petroleum Hydrocarbons by EPA 418.1.

^d Ca CO₃ = Calcium Carbonate

^e TKN = Total Kjeldahl Nitrogen

ND = None Detected. Detection limits are in parentheses.

NA = Not Analyzed

2.3.2 Initial Soil Gas Chemistry

Prior to initiating air injection for the respiration test, the VW and MP were purged and initial oxygen, carbon dioxide, and TVH concentrations were measured using portable gas analyzers, as described in the protocol document.

Table 2.2 summarizes the initial soil gas chemistry at the site. The results indicate that biological fuel degradation has depleted the oxygen supply in the vadose zone. The VW and MPA contained oxygen levels of 4.8 to 8.1 percent. Carbon dioxide was present at elevated concentrations, ranging from 7.8 to 14.1 percent.

2.3.3 *In Situ* Respiration Rates

An *in situ* respiration test was conducted at the site according to protocol document procedures. A 1-cfm pump was used to inject air into the VW for 22 hours. Helium, at a concentration of between 2.5 and 4 percent was injected for use as a tracer gas. Oxygen concentrations at the VW were increased to 20 percent. After air injection ceased, changes in soil gas composition were monitored over time. Oxygen, carbon dioxide, TVH, and helium were measured over a period of 121 hours following the air injection period. The observed rate of oxygen utilization was then used to estimate the aerobic fuel degradation rate at the site using procedures outlined in Section 5.7 of the protocol document. Figure 2.6 presents the results of *in situ* respiration testing at the site, and Table 2.3 provides a summary of the observed oxygen utilization rate.

At IRP Site 43, an estimated 100 milligrams (mg) of fuel per kilogram (kg) of soil can be degraded each year. This value was calculated for the VW, the only contaminated point, using the observed oxygen utilization rate and an estimated air-filled porosity of 0.07 liter per kilogram of soil and a conservative ratio of 3.5 mg of oxygen consumed for every 1 mg of fuel biodegraded. Oxygen decrease during the respiration test was steady. The oxygen utilization rate observed in the contaminated soil at the VW was approximately 0.0007 percent per minute (%/min). This low rate of oxygen utilization was partially the result of vent well dilution, since the upper portion of the screened interval was not in contaminated soil.

2.3.4 Air Permeability

An air permeability test was conducted at the site according to protocol document procedures. Air was injected into the VW for approximately 22 hours at a rate of approximately 1 cfm. This injection rate was not sufficient to cause pressure responses in the monitoring points. However, as discussed below, oxygen influence was achieved and, therefore, soil permeability is high enough to allow remediation of soils within a 7-foot radius of the VW with this low flow rate.

2.3.5 Oxygen Influence

The depth and radius of oxygen influence in the subsurface resulting from air injection into the central VW during pilot testing is the primary design parameter for full-scale bioventing systems. Optimization of full-scale and multiple VW systems requires pilot testing to determine the volume of soil that can be oxygenated at a given flow rate and VW screen configuration.

Table 2.2

Initial Soil Gas Chemistry
 IRP Site 43, Building 1200 Former Diesel UST
 Edwards AFB, California

Sample Location	Depth (ft bgs)	O ₂ (percent)	CO ₂ (percent)	TVH-Field (ppmv) ^a	TVH-Lab (ppmv) ^b	Temperature (°F)
ED3-VW	4-14	8	7.8	240	690	NA
ED3-MPA-5	5	4.8	14.1	115	NA	80.2
ED3-MPA-10	10	6.9	16	110	NA	NA
ED3-MPA-15	15	8.1	11.9	125	76	69.3

^a Total hydrocarbon analyzer field screening results.

^b Laboratory results referenced to Jet Fuel (Molecular Weight = 156)

NA = Not Analyzed

Table 2.3
Oxygen Utilization Rates
IRP Site 43, Building 1200 Former Diesel UST
Edwards AFB, California

Location	O ₂ Loss ^a (percent)	Test Duration (min.)	O ₂ Utilization ^a Rate (percent/min)	Hydrocarbon Degradation Rate (mg/kg/yr)
VW	5.2	7,237	0.0007	100

^a Value based on linear regression (Figure 2.6).

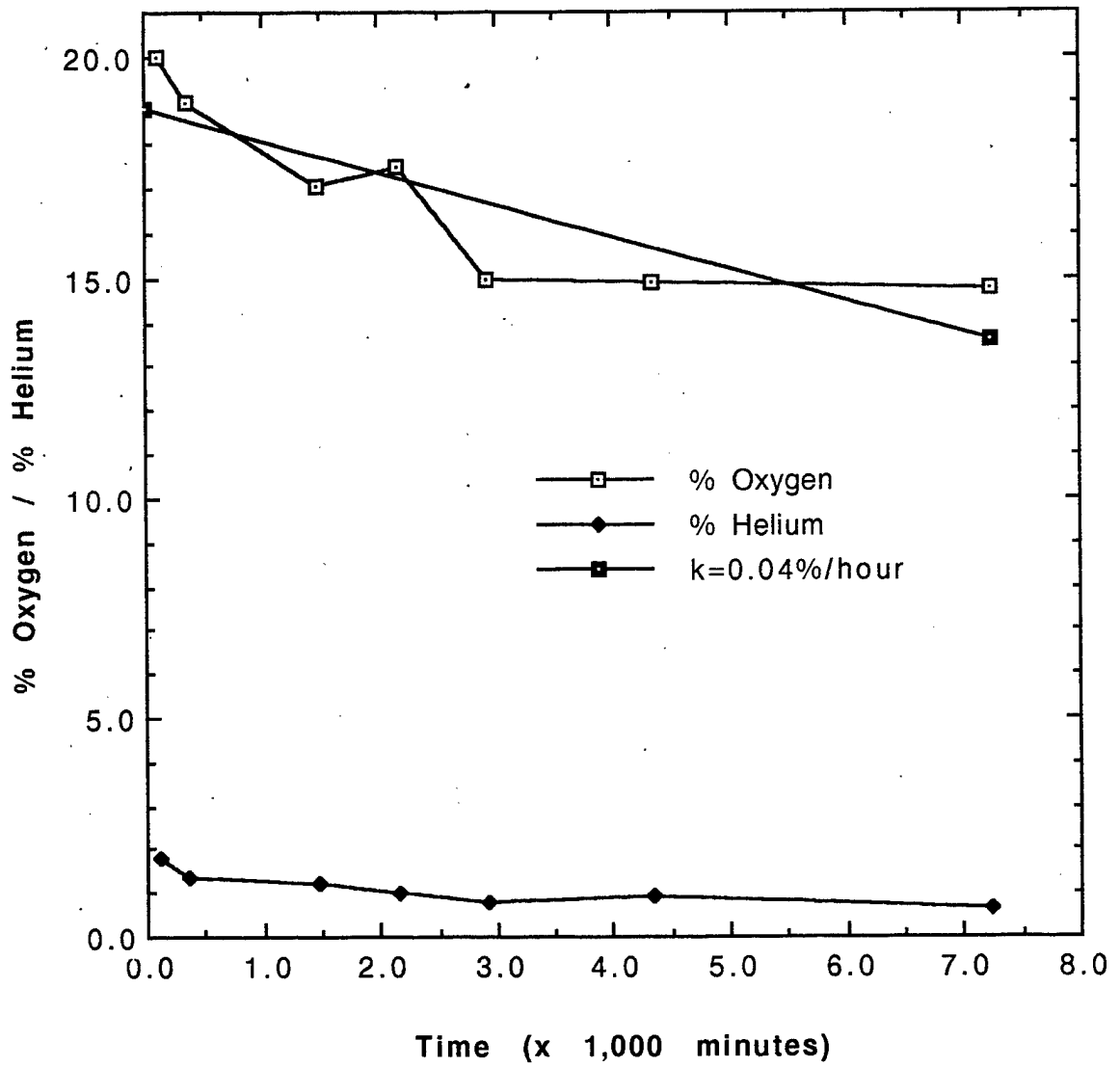

FIGURE 2.6
Respiration Test
ED3-VW
 IRP Site 43, Building 1200
 Former Diesel UST Site
 Engineering-Science, Inc. **ES**

Table 2.4 describes the change in soil gas oxygen levels that occurred after 22 hours of air injection during the air permeability test at the site. The air injection flow rate of 1 cfm produced an increase in soil gas oxygen levels at a distance of at least seven feet from the central VW. Based on oxygen influence during the test, it is anticipated that the radius of influence for a long-term bioventing system at this site will exceed seven feet at all depths.

2.3.6 Potential Air Emissions

Site contamination consists of diesel fuel, a compound of relatively low volatility. Soil samples had maximum field head space readings of 296 ppm. Maximum soil concentrations of BTEX compounds detected were 1.6 mg/kg for xylenes and 0.37 mg/kg for ethylbenzene, whereas benzene was not detected in any sample. Maximum TVH in the soil gas analyzed was 690 ppmv. The long-term potential for air emissions from bioventing operations at this site is low. Initial emissions should be minimal as accumulated vapors will move slowly outward from the air injection point, and will be biodegraded as they move horizontally through the soil.

2.4 Recommendations

Initial bioventing tests at this site indicate that oxygen had been depleted in the contaminated soils, and that air injection is an effective method of stimulating aerobic fuel biodegradation. AFCEE has recommended that air injection continue at this site to determine the long-term radius of oxygen influence and the effects of time, available nutrients, and changing temperatures on fuel biodegradation rates.

A 1-horsepower regenerative blower has been installed at the site for continuous air injection. In March 1994, ES will return to the site to sample and analyze the soil gas, and conduct a repeat respiration test. In September 1994, a final respiration test will be conducted, and soil and soil gas samples will be collected from the site to determine the degree of remediation achieved during the first year of *in situ* treatment.

3.0 REFERENCES

- Engineering-Science, Inc. *Field Sampling Plan for AFCEE Bioventing*. Denver, Colorado. 1992.
- Hinchee, R.E., Ong, S.K., Miller, R.N., Downey, D.C., and Frandt, R. *Test Plan and Technical Protocol for a Field Treatability Test for Bioventing*. January 1992.

Table 2.4

Influence of Air Injection Vent Well on Monitoring Point Oxygen Levels
IRP Site 43, Building 1200 Former Diesel UST
Edwards AFB, California

Sample Location	Distance from VW (ft)	Depth (ft. bgs)	Initial O ₂ (percent)	Final O ₂ ^a (percent)
ED3-MPA-5	7	5	4.8	14.2
ED3-MPA-10	7	10	6.9	19
ED3-MPA-15	7	15	8.1	14.2

^a Readings taken after 22 hours of air injection during air permeability test.

NS = Not Sampled

APPENDIX A

APPENDIX A
OPERATION & MAINTENANCE MANUAL

**REGENERATIVE BLOWER
OPERATION AND MAINTENANCE MANUAL
FOR EXTENDED TESTING SYSTEM AT
EDWARDS AIR FORCE BASE
BUILDING 1200, IRP SITE 43**

Prepared for

**Air Force Center for Environmental Excellence
Brooks AFB, Texas
USAF Contract F33615-90-D-4014, Delivery Order 14**

January 1994

Prepared by

**Engineering-Science, Inc.
DESIGN ■ RESEARCH ■ PLANNING
199 South Los Robles Avenue ■ P.O. Box 7056 ■ Pasadena, CA 91109**

**REGENERATIVE BLOWER
OPERATIONS AND MAINTENANCE MANUAL
FOR EXTENDED TESTING SYSTEM AT
EDWARDS AIR FORCE BASE,
BUILDING 1200, IRP SITE 43**

Prepared for:

**AIR FORCE CENTER FOR ENVIRONMENTAL EXCELLENCE
BROOKS AFB, TEXAS**

USAF CONTRACT F33615-90-D-4014, DELIVERY ORDER 14

JANUARY 1994

Prepared by:

**Engineering-Science, Inc.
199 South Los Robles Avenue
Pasadena, California**

SECTION 1

INTRODUCTION

This document has been prepared by Engineering-Science, Inc., to support the bioventing initiative contract awarded by the Air Force Center for Environmental Excellence. The contract involves the conducting of bioventing pilot tests at 35 sites on 23 Air Force Bases across the United States.

At most sites, bioventing systems will be installed upon completion of the bioventing pilot tests for the purpose of extended pilot testing. These systems will operate for a one year period to provide further information as to the feasibility of the technology at each site, and to provide interim remedial action.

The Operations and Maintenance Manual has been created for sites at which blowers have been installed for extended pilot testing. Basic maintenance of these systems is the responsibility of the base. The manual is to be used by base personnel to guide and assist them in operating and maintaining the blower system. Section 2 provides a synopsis of the blower system configuration. Section 3 of this document describes the blower. Section 4 details the maintenance requirements and provides maintenance schedules. Section 5 describes the system monitoring that is required to forecast system maintenance needs and provide data for the extended pilot test.

SECTION 2

BLOWER SYSTEM CONFIGURATION SUMMARY

System Type injection

Blower regenerative

Blower Model R4110N-50

Motor (Horsepower) 1.0

Knock-Out Chamber none

Sampling Port none

Inlet Temperature Gauge (range) not applicable

Inlet Vacuum Gauge (range) -60" - 0" H₂O

Inlet Filter (part no.) AJ134E

Outlet Temperature Gauge (range) 0°-250° F

Outlet Pressure Gauge (range) 0" - 60" H₂O

Pressure/Vacuum Relief Valve Set @ (give unit of measure) 30" H₂O

SECTION 3

BIOVENTING SYSTEM OPERATION

3.1 PRINCIPLE OF OPERATION

Bioventing is the forced injection of fresh air, or withdrawal of soil gas, to enhance the supply of oxygen for *in situ* bioremediation. Either a pressure (air injection) or vacuum (vapor extraction) blower unit is used to inject or withdraw air into or from the soil, thereby supplying fresh air with 20.8 percent oxygen to the contaminated soils. Once oxygen is provided to the subsurface, existing bacteria will proceed with the breakdown of fuel residuals.

An injection blower system has been installed at Edwards Air Force Base Building 1200, IRP Site 43.

3.2 SYSTEM DESCRIPTION

3.2.1 Blower System

A Gast series R4 blower powered by a one horsepower direct-drive motor is the workhorse of this bioventing system. This blower is rated at a flow rate of 92 standard cubic feet per minute (scfm) at open flow; however, the actual performance of the blower will vary with changing site conditions. As installed at Building 1200, the blower was producing an estimated flow rate of 40 scfm at a pressure of 5 inches of water with much of the flow being released at the bleed off valve, which was completely open. This was necessary because the contaminated area was very limited and only a very low flow rate was required to aerate the entire contaminated soil volume. The system includes an air filter to remove any particulates which are entrained in the air stream, and several valves and monitoring gauges which are described in the next section. A schematic of the blower system installed at Building 1200 is shown on the figure in Attachment A. Corresponding blower performance curves, and relevant service information are also provided in Appendix A.

3.2.2 Monitoring Gauges

The bioventing system is equipped with vacuum, pressure, and temperature gauges. Gauges have been installed on the air injection system at the following locations: a vacuum gauge in the inlet piping, a pressure and a temperature gauge in the outlet piping. The temperature gauge is used to monitor the outlet temperature to determine the change in temperature across the blower. Ambient air temperature can be estimated and used as the inlet temperature since an inlet temperature gauge is not present. See the figure in the attachment for the locations of the gauges installed on the blower system.

SECTION 4

SYSTEM MAINTENANCE

Although the motor and blower are relatively maintenance free, periodic system maintenance is required for proper operation and long life. Recommended maintenance procedures and schedules are described in detail in the instruction manuals included in Attachments A and B and briefly summarized in this section.

Filter inspection must be performed with the system turned off. To re-start the motor, open the manual air dilution valve to protect the motor from excessive strain, start motor, and slowly close dilution valve. If the handle has been removed from the manual air dilution valve, do not open the valve or otherwise change the setting (it has been pre-set for a specific flow rate) before re-starting the blower.

4.1 BLOWER/MOTOR

The blower and motor are relatively maintenance free and should not require any periodic maintenance during the 1-year extended testing period. Both blower and motor have sealed bearings and do not require lubrication.

4.2 AIR FILTER

To avoid damage caused by passing solids through the blower, an air filter has been installed in-line before the blower. The filter element is paper and is accompanied by a polyurethane foam prefilter. The filter should be checked weekly for the first 2 months of operation. Afterward, a facility employee should determine the best schedule for filter replacement. The polyurethane prefilters can be washed with lukewarm water and a mild detergent. Paper filter elements should never be washed, but should be disposed of and replaced as necessary. When the pressure or vacuum drop across the blower is above 25 inches of water, a dirty filter element should be suspected, and cleaning or replacement should be performed.

To remove the filter, loosen the wing nut, lift the metal top off the air filter, and lift the air filter from the metal housing. Remove the polyurethane prefilter (if applicable) and wash before replacing. When replacing the filter, be careful that the rubber seals remain in place.

The filter element is manufactured by Gast Manufacturing Corp. in Benton Harbor, Michigan. Their telephone number is (616) 926-6171. Additional filters can also be obtained through Engineering-Science, Inc., in Pasadena, California. The ES contact is Mr. Chris Pluhar. He can be reached at (818) 585-6324. The filter model number

is AJ126D, and the number for the replacement element is AJ134E. It is recommended that at least one spare air filter be kept at the site, four spare filters were supplied with the blower system.

4.3 MAINTENANCE SCHEDULE

The following maintenance schedule is recommended for this system. The filter should be checked once per month and washed or replaced as necessary (see Section 5.2). During the initial months of operation more frequent monitoring is recommended to ensure that any startup problems are quickly corrected. A daily drive-by inspection is recommended during the initial 2 weeks of operation to ensure that the blower system is still operating with no unusual sounds. Data collection sheets that can be used to record maintenance activities are included in Attachment B.

4.4 TROUBLESHOOTING

<u>Symptoms</u>	<u>Possible Diagnosis</u>	<u>Possible Remedy</u>
Excess Vibration	Impeller damaged by foreign material Impeller contaminated by foreign material	Replace impeller Clean impeller, install adequate filtration
Abnormal Sound	Motor bearing failed Impeller rubbing against cover or housing	Replace bearings Repair blower, check clearances
Increase in Sound	Foreign material can coat or destroy muffler foam	Replace foam muffler elements, trap or filter foreign material
Blown Fuse	Electrical wiring problem	Have qualified person check fuse capacity and wiring
Unit Very Hot	Running at too high a pressure or vacuum	Install or adjust relief valves

4.5 MAJOR REPAIRS

Blowers systems are very reliable when properly maintained. Occasionally, a motor or blower will develop a serious problem. If a blower system fails to start, and a qualified electrician verifies that power is available at the blower or starter, the ES Site Manager, Chris Pluhar, should be called at (818) 585-6324. ES is responsible for major repairs during the first year of operation.

SECTION 5

SYSTEM MONITORING

5.1 BLOWER PERFORMANCE MONITORING

To monitor the blower performance, vacuum, pressure, and temperature will be measured. These data should be recorded weekly on a data collection sheet (provided in Attachment B). All measurements should be taken at the same time while the system is running. Because the system is loud, hearing protection should be worn at all times.

5.1.1 Vacuum/Pressure

With hearing protection in place, open the blower enclosure and record all vacuum and pressure readings directly from the gauges (in inches of water or psi). Record the measurements on a data collection sheet (Attachment B).

5.1.2 Flow Rate

The flow rate through the vent well and soils can be calculated when the inlet vacuum and outlet pressure of the blower are known. This pressure change across the blower (vacuum + pressure) can be compared to the performance curves for the blower in Attachment A to determine the approximate flow rate.

5.1.3 Temperature

With hearing protection in place, open the blower enclosure and record the temperature readings directly from the gauges in degrees Fahrenheit (°F). Record the measurements on a data collection sheet (provided in Attachment B). The temperature change can be converted to degrees Celsius (°C) using the formula $^{\circ}\text{C} = (^{\circ}\text{F} - 32) \times 5/9$.

5.2 MONITORING SCHEDULE



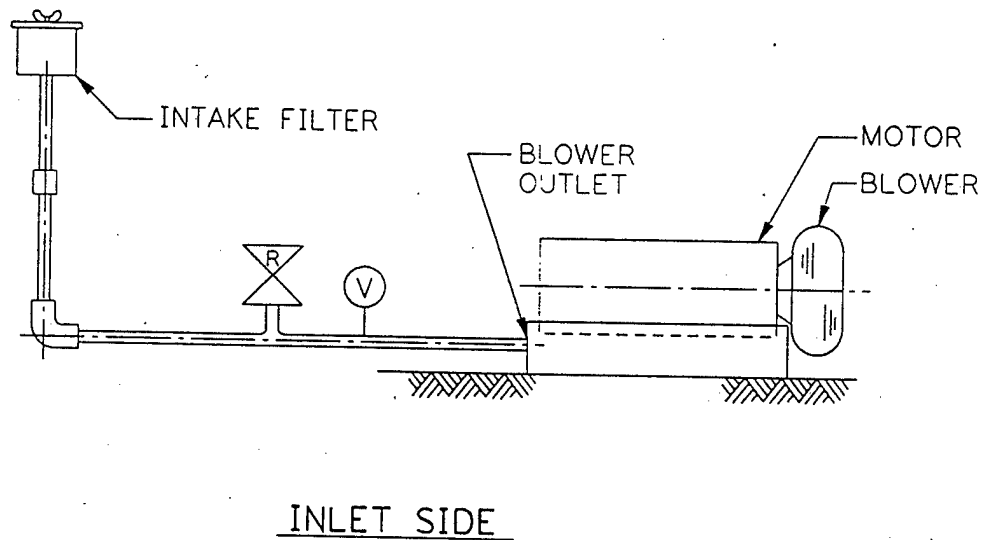
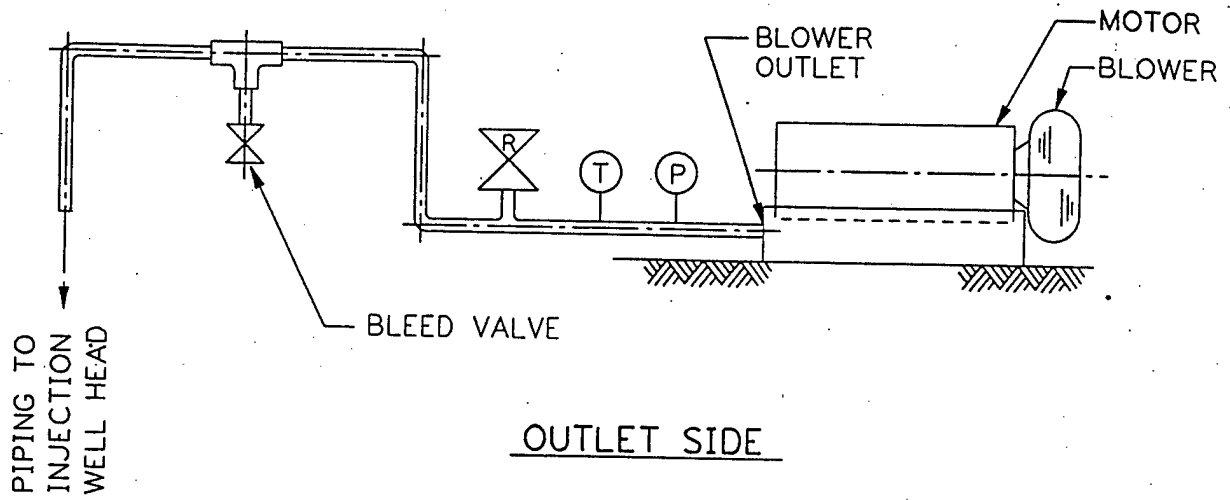

The following monitoring schedule is recommended for this system. During the initial months of operation, more frequent monitoring is recommended to ensure that any start up problems are quickly corrected. Data collection sheets have been provided to assist your data collection and are included in Attachment B.

Monitoring Item	Monitoring Frequency
Vacuum/Pressure	Daily during first week, then once per week.
Temperature	Daily during first week, then once per week.
Filter	Weekly during first two months, then as necessary.

ATTACHMENT A



LEGEND

- 
 TEMPERATURE GAUGE (1/4" NPT)
- 
 PRESSURE GAUGE (1/4" NPT)
- 
 VACUUM GAUGE (1/4" NPT)
- 
 PRESSURE OR VACUUM RELIEF VALVE

NOT TO SCALE

REGENERATIVE BLOWER
SYSTEM FOR AIR
INJECTION

ENGINEERING-SCIENCE, INC.
Pasadena, California





70-6100
F2-205/8/92
Rev. E

Post Office Box 97
Benton Harbor, MI. 49023-0097
Ph: 616/926-6171
Fax: 616/925-8288

INSTALLATION AND OPERATING INSTRUCTIONS FOR GAST HAZARDOUS DUTY REGENAIR BLOWERS

This instruction applies to the following models ONLY: R3105N-50, R4110N-50, R4310P-50, R4P115N-50, R5125Q-50, R5325R-50, R6130Q-50, R6P155Q-50, R6350R-50, R6P355R-50 and R7100R-50.

Gast Authorized Service Facilities are Located in the locations listed below

Gast Manufacturing Corporation
505 Washington Avenue
Carlstadt, N. J. 07072
Ph: 201/933-8484
Fax: 201/933-5545

Gast Manufacturing Corporation
2550 Meadowbrook Road
Benton Harbor, MI. 49022
Ph: 616/926-6171
Fax: 616/925-8288

Brenner Fiedler & Associates
13824 Bentley Place
Cerritos, CA. 90701
Ph: 310/404-2721
Ph: 800/843-5558
Fax: 310/404-7975

Wainbee Limited
215 Brunswick Blvd.
Pointe Claire, Quebec
Canada H9R 4R7
Ph: 514/697-8810
Fax: 514/697-3070

Wainbee Limited
5789 Coopers Ave.
Mississauga, Ontario
Canada L4Z 3S6
Ph: 416/243-1900
Fax: 416/243-2336

Japan Machinery
Central PO Box 1451
Toyko 100-91, Japan
Ph: 813 3573-5421
Fax: 813 3571-7896

Gast Manufacturing Co. Ltd.
Halifax Road, Cressex Estate
High Wycombe, Bucks HP12 3SN
England
Ph: 44 494 523571
Fax: 44 494 436588

OPERATING AND MAINTENANCE INSTRUCTIONS

SAFETY

This is the safety alert symbol. When you see this symbol personal injury is possible. The degree of injury is shown by the following signal words:

- ⚠ DANGER** Severe injury or death will occur if hazard is ignored.
- ⚠ WARNING** Severe injury or death can occur if hazard is ignored.
- ⚠ CAUTION** Minor injury or property damage can occur if hazard is ignored.

Review the following information carefully before operating.

GENERAL INFORMATION

This instruction applies to the following models ONLY: R3105N-50, R4110N-50; R4310P-50, R4P115N-50, R5125Q-50, R5325R-50, R6130Q-50, R6P155Q-50, R6350R-50, R6P355R-50 and R7100R-50. These blowers are intended for use in Soil Vapor Extraction Systems. The blowers are sealed at the factory for very low leakage. They are powered with a U.L. listed electric motor Class 1 Div. 1 Group D motors for Hazardous Duty locations. Ambient temperature for normal full load operation should not exceed 40° C (105° F). For higher ambient operation, contact the factory.

Gast Manufacturing Corporation may offer general application guidance; however, suitability of the particular blower and/or accessories is ultimately the responsibility of the user, not the manufacturer of the blower.

INSTALLATION

- ⚠ DANGER** Models R5325R-50, R6130Q-50, R6350R-50, R5125Q-50, R6P155Q-50, R6P355R-50 AND R7100R-50 use Pilot Duty Thermal Overload Protection. Connecting this protection to the proper control circuitry is mandated by UL674 and NEC501. Failure to do so could/ may result in a EXPLOSION. See pages 3 and 4 for recommended wiring schematic for these models.

- ⚠ WARNING** Electric shock can result from bad wiring. A qualified person must install all wiring, conforming to all required safety codes. Grounding is necessary.

- ⚠ WARNING** This blower is intended for use on soil vapor extraction equipment. Any other use must be approved in writing by Gast Manufacturing Corp. Install this blower in any mounting position. Do not block the flow of cooling air over the blower and motor.

PLUMBING - Use the threaded pipe ports for connection only. They will not support the plumbing. Be sure to use the same or larger size pipe to prevent air flow restriction and overheating of the blower. When installing fittings, be sure to use pipe thread sealant. This protects the threads in the blower housing and prevents leakage. Dirt and chips are often found in new plumbing. Do not allow them to enter the blower.

NOISE - Mount the unit on a solid surface that will not increase the sound. This will reduce noise and vibration. We suggest the use of shock mounts or vibration isolation material for mounting.

ROTATION - The Gast Regenair Blower should only rotate clockwise as viewed from the electric motor side. The casting has an arrow showing the correct direction. Confirm the proper rotation by checking air flow at the IN and OUT ports. If needed reverse rotation of three phase motors by changing the position of any two of the power line wires.

OPERATION

- ⚠ WARNING** Solid or liquid material exiting the blower or piping can cause eye damage or skin cuts. Keep away from air stream.

- ⚠ WARNING** - Gast Manufacturing Corporation will not knowingly specify, design or build any blower for installation in a hazardous, combustible or explosive location without a motor conforming to the proper NEMA or U. L. standards. Blowers with standard TEFC motors should never be utilized for soil vapor extraction applications or where local state and/or Federal codes specify the use of explosion-proof motors (as defined by the National Electric Code, Articles 100,500 c1990).

- ⚠ CAUTION** Attach blower to solid surface before starting to prevent injury or damage from unit movement. Air containing solid particles or liquid must pass through a filter before entering the blower. Blowers must have filters, other accessories and all piping attached before starting. Any foreign material passing through the blower may cause internal damage to the blower.

- ⚠ CAUTION** Outlet piping can burn skin. Guard or limit access. Mark "CAUTION Hot Surface. Can Cause Burns". Air temperature increases when passing through the blower. When run at duties above 50 in. H₂O, metal pipe may be required for hot exhaust air. The blower must not be operated above the limits for continuous duty. Only models R3105N-50, R4110N-50 and R4310P-50 can be operated continuously with no air flowing through the blower. Other units can only be run at the rating shown on the model number label. Do not Close off inlet (for vacuum) to reduce extra air flow. This will cause added heat and motor load. Blower exhaust air in excess of 230°F indicates operation in excess of rating which can cause the blower to fail.

ACCESSORIES...Gast pressure gauge AJ496 and vacuum gauges AJ497 or AE134 show blower duty. The Gast pressure/vacuum relief valve, AG258, will limit the operating duty by admitting or relieving air. It also allows full flow through the blower when the relief valve closes.

SERVICING

⚠ WARNING To retain their sealed construction they should be serviced by Gast authorized service centers ONLY. These models are sealed at the factory for very low leakage.

⚠ WARNING Turn off electric power before removing blower from service. Be sure rotating parts have stopped. Electric shock or severe cuts can result. Inlet and exhaust filters attached to the blower may need cleaning or replacement of the elements. Failure to do so will result in more pressure drop, reduced air flow and hotter opera-

tion of the blower. The outside of the unit requires cleaning of dust and dirt. The inside of the blower also may need cleaning to remove foreign material coating the impeller and housing. This should be done at a Gast Authorized Service Center. This buildup can cause vibration, failure of the motor to operate or reduced flow.

KEEP THIS INFORMATION WITH THIS BLOWER. REFER TO IT FOR SAFE INSTALLATION, OPERATION OR SERVICE.

MOTOR WIRING DIAGRAM FOR R4110N-50 & R3105N-50

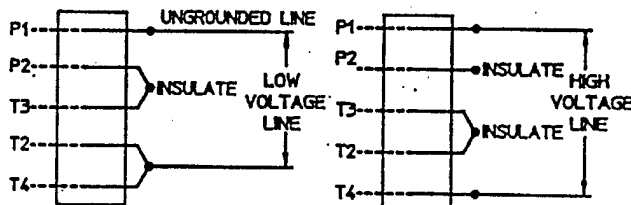

>> * WARNING
THIS MOTOR IS THERMALLY PROTECTED AND WILL AUTOMATICALLY RESTART WHEN PROTECTOR RESETS. ALWAYS DISCONNECT POWER SUPPLY BEFORE SERVICING.

MOTORS WIRING DIAGRAM FOR R4310P-50

TO REVERSE ROTATION, INTERCHANGE THE EXTERNAL CONNECTIONS TO ANY TWO LEADS.

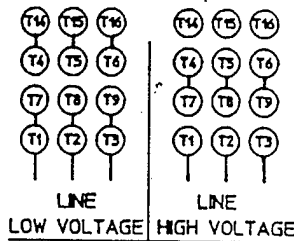

>> * WARNING
THIS MOTOR IS THERMALLY PROTECTED AND WILL AUTOMATICALLY RESTART WHEN PROTECTOR RESETS. ALWAYS DISCONNECT POWER SUPPLY BEFORE SERVICING.

MOTORS WIRING DIAGRAM FOR R5325R-50, R6350R-50, R6P355R-50, & R7100R-50

TO REVERSE ROTATION, INTERCHANGE THE EXTERNAL CONNECTIONS TO ANY TWO LEADS.

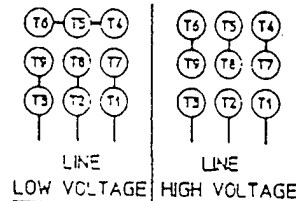
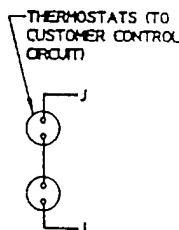

Oilless Regenerative Blowers, Motor Mounted to 92 cfm



REGENAIR® R4 Series

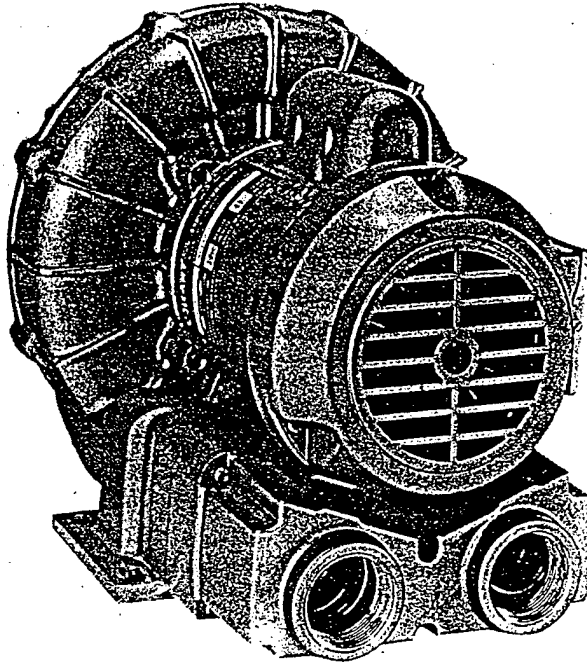

MODEL R4110-2
52" H₂O MAX. PRESSURE, 92 CFM OPEN FLOW

PRODUCT FEATURES

- Oilless operation
- TEFC motor mounted
- Can be mounted in any plane
- Rugged construction/low maintenance
- Can be operated blanked-off

COMMON MOTOR OPTIONS

- 115/208-230V, 60 Hz; 110/220-240V, 50 Hz, single phase
- 208-230/460V, 60 Hz; 190-230/380-415V, 50 Hz, three phase
- 575V, 60 Hz, three phase

RECOMMENDED ACCESSORIES

- Pressure gauge AJ496
- Filter AG338
- Muffler AJ121D
- Relief valve AG258

Various brand name motors are used on any model at the discretion of Gast Mfg. Corp.

Important Notice:

Pictorial and dimensional data is subject to change without notice.

Product Dimensions Metric (mm) U.S. Imperial (inches)

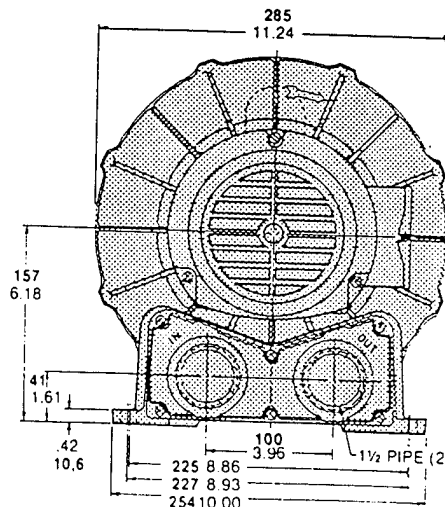
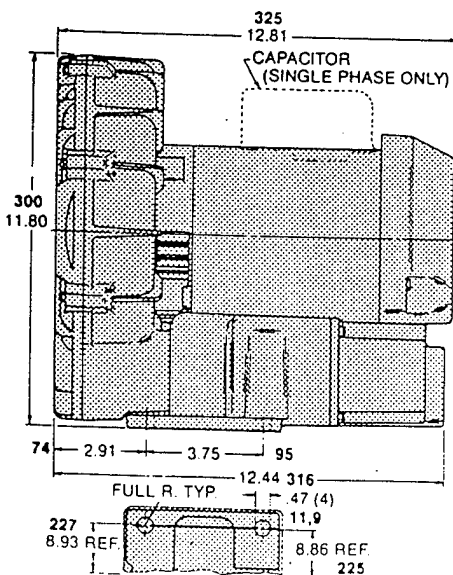

Product Specifications

Model Number	Motor Specs	Full Load Amps	HP	RPM	Max Pressure		Max Flow		Net Wt.	
					"H ₂ O	mbar	cfm	m ³ h	lbs.	kg
R4110-2	110/220-240-50-1	9.0/4.5-5.7	0.6	2850	38	95	74	126	41	18,6
	115/208-230-60-1	9.8/5.2-4.9	1.0	3450	52	130	92	156		
R4310A-2	190-220/380-415-50-3	2.6-3.3/1.3-1.4	0.6	2850	38	95	74	126	41	18,6
	208-230/460-60-3	3.4-3.2/1.6	1.0	3450	52	130	92	156		

Product Performance (Metric U.S. Imperial) Black line on curve is for 60 cycle performance.
Blue line on curve is for 50 cycle performance.

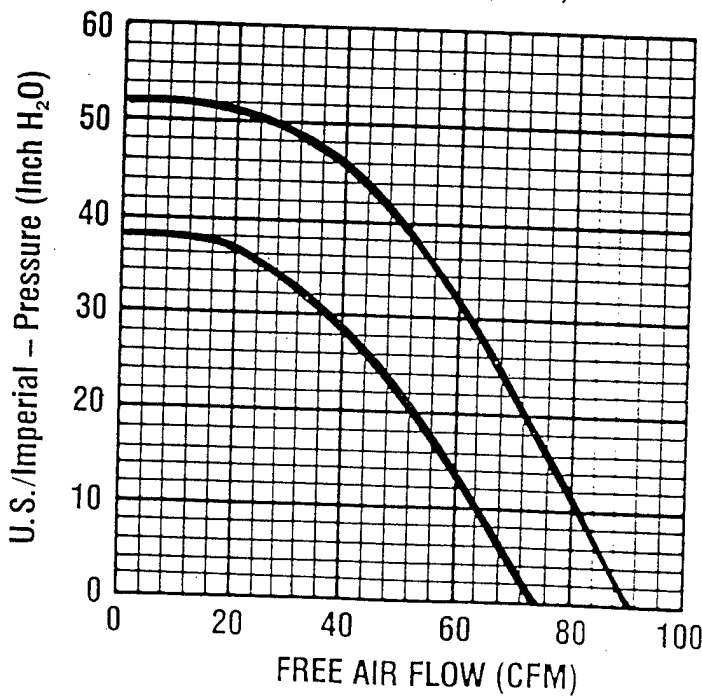
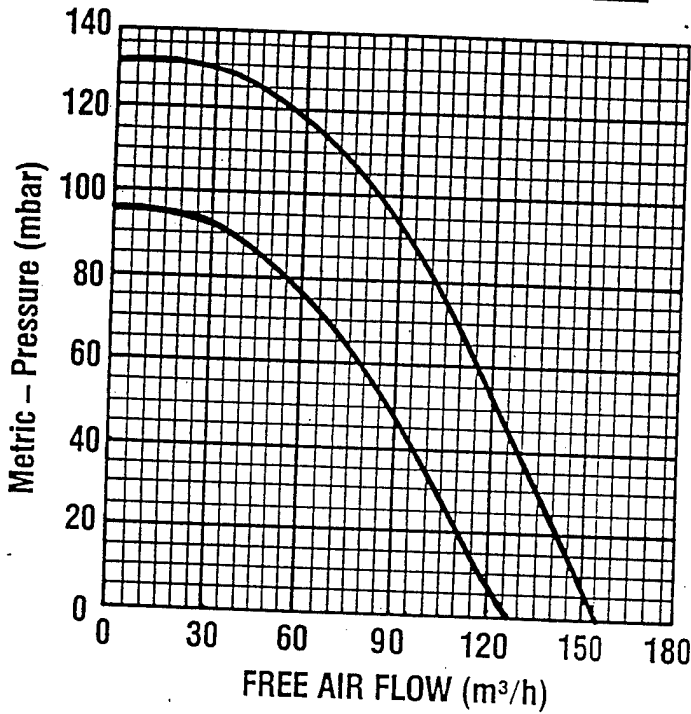



MANUFACTURING CORPORATION

P. O. BOX 97, BENTON HARBOR, MICHIGAN 49022
PHONE 616-926-6171

70-6300
F2-105
6/88

Blower Relief Valve Operating Instructions (AG258)

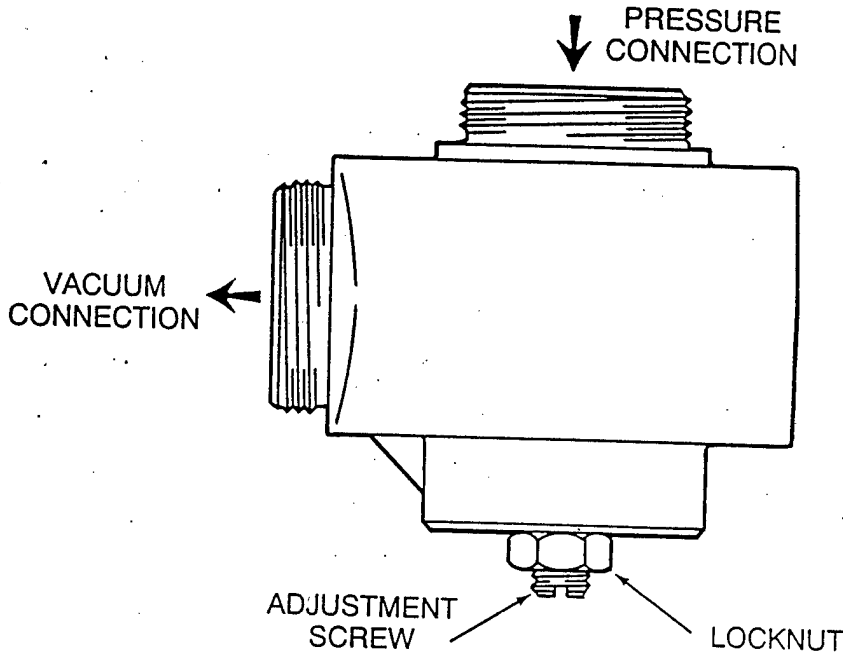

Operating the Regenair Regenerative blowers with more than 1 HP motors and insufficient air flow can result in damage to the blower caused by excessive heating of the air passing through the blower.

The AG258 blower relief valve can be adjusted to limit the pressure and/or vacuum level and maintain adequate air flow through the blower to prevent damage from excessive heat.

The adjusting of the relief valve is accomplished by loosening the lock nut on the adjusting screw and turning the adjusting screw with the blade of a screwdriver. Turning the adjusting screw clockwise will increase the relief valve setting and counter clockwise will decrease the setting. Hold the screwdriver in place when retightening the lock nut. The use of the Gast pressure (AE133) or vacuum (AE134) gauge will provide an accurate setting.

The valve is position sensitive. The recommended installation position is with the adjusting screw positioned vertically down. Final adjustments to change the setting up to 15 inches of water may be made by rotating the valve up to 20 degrees from vertical.

CAUTION: For units with air flows exceeding 200 CFM two relief valves should be used in parallel to provide proper cooling to the blower.

All components of the valve are made of corrosion resistant metal. In normal operation the only maintenance required is cleaning the valve with Gast Flushing Solvent (AH255A). Often the valve need not be disassembled to clean. Particular attention should be given to cleaning the small hole through the center of the piston. If this becomes clogged the valve will not function properly. A pin or small diameter wire may be used to clean the blocked hole.

WARNING: WHEN INSTALLING THE PRESSURE/VACUUM RELIEF VALVE, ALL POWER SOURCES TO THE ELECTRIC MOTOR AND ANY ACCESSORY DEVICES SHOULD BE DISCONNECTED AND ALL ROTATING PARTS SHOULD BE AT A STANDSTILL OR BODILY INJURY COULD RESULT.

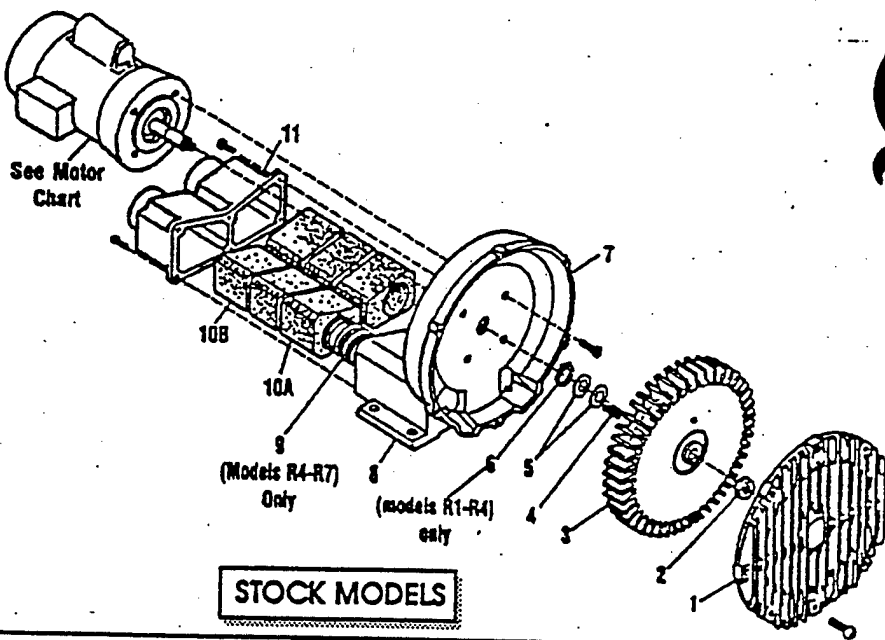

STOCK MODELS

Name	R1	R2	R3	R4	R5	R6	R6P	R6PP/R6PS	R7
Cover	AJ101A	AJ101B	AJ101C	AJ101D	AJ101EQ	AJ101F	AJ101K	(2)AJ101KA	AJ101G
Topnut	BC187	BC187	BC181	BC181	BC181	BC181	BC181	(2)BC182	BC183
Impeller	AJ102A	AJ102BQ	AJ102C	AJ102D	AJ102E	AJ102ER	AJ102K	(2)AJ102KA	AJ102GA
Square Key	AH212C	AH212	AB136A	AB136D	AB136	AB136	AB136	(2)AB136	AC628
Shim Spacer (s)	AJ132	AE686-3	AJ109	AJ109	AJ109	AJ116A	AJ116A	AJ116A	AJ110
Retaining Ring	AJ145	AJ145	AJ149	AJ149	AJ109	AJ116A	AJ116A	AJ116A	AJ110
Housing	AJ103A	AJ103BQ	AJ103C	AJ103DR	AJ103E	AJ103F	AJ103K	AJ103KD	AJ103GA
Muffler Box					AJ104E	AJ104F			
Spring				AJ113DR	AJ113DQ	AJ113FQ	AJ113FQ		
A Foam	(4)AJ112A	(4)AJ112B	(4)AJ112C	(4)AJ112DS	(4)AJ112ER	(6)AJ112F	(8)AJ112K		AJ113G
B Foam		(2)AJ112BQ	(2)AJ112CQ	(2)AJ112DR	(2)AJ112EQ				(8)AJ112GA
Muffler Extension/ Adapter Plate	AJ106H	AJ106BQ	AJ106CQ	AJ106DQ	AJ106EQ	AJ106EQ	AJ104K		AJ104GA
Kit	K396	K396							K395

MOTOR CHART

EGENAIR MODEL NUMBER	MOTOR NUMBER	MOTOR SPECIFICATIONS		PHASE
		60 HZ VOLTS	50 HZ VOLTS	
2102	J111X	115/208-230	110/220-240	1
2102C	J112X	115		1
2103	J311X	115/208-230	110/220	1
2105	J411X	115/208-230	110/220	1
303A	J310	208-230/460	220/380-415	3
303F	J313	208-230	220	3
3105-1/R3105-12	J411X	115/208-230	110/220-240	1
3305A-1/R3305A-13	J410	208-230/460	220/380-415	3
510-2	J611AX	115/208-230	110/220-240	1
510A-2	J610	208-230/460	220/380-415	3
5125-2	J811X	115/208-230		1
5325A-2	J810X	208-230/460	220/380-415	3
525-2	J811X	115/208-230		1
525A-2	J810X	208-230/460	220/380-415	3
5335A-2	J910X	208-230/460	220/380-415	3
550J-2	J1013	230		1
550A-2	J1010	208-230/460	220/380-415	3
5P335A	J910X	208-230/460	220/380-415	3
5P350A	J1010	208-230/460	220/380-415	3
5355A	J1110A	208-230/460	220/380-415	3
5DOA-2*	J1210B	208-230/460	220/380-415	3
5PP/R6PS3110M	JD1100	208-230/460	220/380-415	3

* No lubrication needed at start up. Bearings lubricated at factory.

* Motor is equipped with alemite fitting. Clean tip of fitting and apply grease gun. Use 1 to 2 strokes of high quality ball bearing grease.

Consistency	Type	Typical Grease
Medium	Lithium	Shell Dolum R

Hours of service per year	Suggested Relube Interval
5,000	3 years
Continual Normal Application	1 year
Seasonal service motor idle for 6 months or more	1 year beginning of season
Continuous-high ambient, dirty or moist applications.	6 months

60 HZ FLOW DATA (CFM)

All performance figures relate to stock models. A few high pressure units may be available. Consult your local distributor.

Regenair Model Number	P R E S S U R E						Maximum Pressure "H ₂ O"
	0"H ₂ O	20"H ₂ O	40"H ₂ O	60"H ₂ O	80"H ₂ O	100"H ₂ O	
R1	26	14					28
R2	42	26					38
R3105-1	52	38	14				42
R3105-12	52	36	23				55
R3305A-13	52	36	23				55
R4	90	70	50				52
R5	145	130	100				65
R6125-2	200	180					35
R6325A-2	200	180	152				40
R6335A-2	205	175	155	135			70
R6350A-2	200	180	150	130	110	80	105
R6P335A	290	250					30
R6P350A	300	260	230	200			60
R6P355A	300	260	230	200	160		90
R7100A-2	420	380	340	310	280	230	115
R6PP311OM	485	452	420	380	330		95
R6PS311OM	265	258	252	244	236	226	170

Regenair Model Number	V A C U U M						Maximum Vacuum "H ₂ O"
	0"H ₂ O	20"H ₂ O	40"H ₂ O	60"H ₂ O	80"H ₂ O		
R1	25	14					26
R2	40	22					34
R3105-1	50	34	9				40
R3105-12	51	34	20				50
R3305A-13	51	34	20				50
R4	82	62	39				48
R5	140	115	90	50			60
R6125-2	190	155	125				45
R6325A-2	190	155	125				45
R6335A-2	190	150	125	100			75
R6350A-2	190	180	150	100	70		90
R6P335A	270	230					37
R6P350A	280	240	210	170			70
R6P355A	280	240	210	170	100		86
R7100A-2	410	350	300	250	170		90
R6PP311OM	470	425	375	320	220		80
R6PS311OM	240	225	210	195	175	130	

This number indicates the maximum static pressure differential recommended (with cooling air still flowing through unit). In general, units 1hp or less can be dead headed. Check with local representative or distributor to verify which models apply.

Operation of the blower above the recommended maximum duty will cause premature failure due to the build up of heat damaging the components.

Performance data was determined under the following conditions:

- 1) Unit in a temperature stable condition.
- 2) Test conditions: Inlet air density at 0.075lbs. per cubic foot. (20°C(68°F), 29.92 in. Hg(14.7PSIA)).
- 3) Normal performance variations on the resistance curve within +/- 10% of supposed data can be expected.
- 4) Specifications subject to change without notice.
- 5) All performance at 60Hz operation.

Accessories for GAST REGENAIR® Blowers

GAUGES – To monitor the system performance so as not to exceed maximum duties. Using two (one on each side of the filter) is a great way to know when the filter needs servicing.

FILTERS – The impeller of a blower passes very close to the housing. It is always wise to have an inlet or in-line filter to ensure troublefree life.

MUFFLERS – Designed to reduce noise by 5-8 dbA and remove high frequency sound associated with all blowers.

RELIEF VALVES – By setting a relief valve at a given pressure/vacuum you can be assured that no harm will come to the blower or products in your application from excessive duties.

FITTINGS – Gast has a complete line of male hose barbs, tees, common elbows and close nipples for easy hook-up.

HORIZONTAL SWING TYPE CHECK VALVE – Designed to prevent back-wash of fluids that would enter the blower. Also prevents air back-streaming if needed. They can be mounted with their discharge either vertical or horizontal. Valve will open with 3" of water pressure.

In-line Filters (for vacuum)

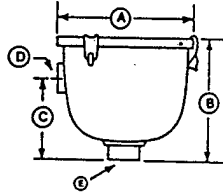

Model No.	R1	R2	R3	R4	SDR4, R5	SDR5, SDR6, R6, R6P	SDR6P, R6PP, R6PS, R7
Part No.	AJ151A	AJ151B	AJ151C	AJ151D	AJ151E	AJ151G	AJ151H
Dim. A	5.93"	7.38"	7.38"	7.38"	8.75"	8.00"	14.00"
Dim. B	4.50"	6.81"	6.81"	6.81"	10.25"	10.25"	26.50"
Dim. C	2.75"	4.62"	4.62"	4.62"	5.00"	5.50"	18.13"
Dim. D	1" FPT	1" FPT	1 1/4" FPT	1 1/2" FPT	2" FPT	2 1/2" FPT	3" MPT
Dim. E	1" FPT	1" FPT	1 1/4" FPT	1 1/2" FPT	2" FPT	2 1/2" FPT	3" MPT
Replacement Element	AJ135D	AJ135E	AJ135E	AJ135E	AJ135F	AJ135G	AJ135C
Micron	10	10	10	10	10	10	10

MPT = Male Pipe Thread
FPT = Female Pipe Thread

Inlet Filters (for pressure units only)

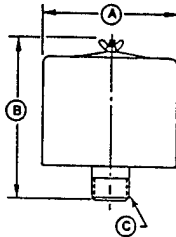

Model No.	R1 & R2	R3	R4, R5 & SDR4	SDR5, R6, SDR6, R6P	R6PP, R6PS, SDR6P, R7
Part No.	AJ126B	AJ126C	AJ126D	AJ126F	AJ126G
Dim. A	6.00"	6.00"	6.00"	10.63"	10.00"
Dim. B	4.62"	7.12"	7.25"	4.81"	13.12"
Dim. C	1" MPT	1 1/4" MPT	1 1/2" MPT	2" FPT	2 1/2" MPT
Replacement Element	AJ134B	AJ134C	AJ134E	AG340	AJ135A
Micron	10	10	10	25	10

MPT = Male Pipe Thread
FPT = Female Pipe Thread
All are heavy-duty for high amounts of particulates.
Inlet filters for REGENAIR® blowers are drip-proof when mounted as shown.

Mufflers

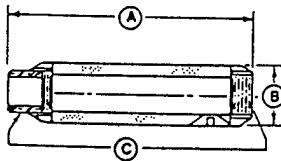

Model No.	R1 & R2	R3	R4, R5, SDR4, SDR5	R6, SDR6P, SDR6, R6P, R6PP, R6PS	R7
Part No.	AJ121B	AJ121C	AJ121D	AJ121F	AJ121G
Dim. A	7.46"	7.94"	12.75"	17.05"	17.44"
Dim. B	2.38"	2.62"	3.25"	3.63"	4.25"
Dim. C	1" NPT	1 1/4" NPT	1 1/2" NPT	2" NPT	2 1/2" NPT

Horizontal Swing Type Check Valve

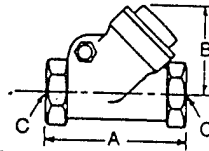

Model No.	R1 & R2	R3	R4, R5, SDR4 & SDR5	R6, R6P, R6PP, R6PS, SDR6 & SDR6P	R7
Part No.	AH326B	AH326C	AH326D	AH326F	AH326G
Dim. A	3.57	4.19	4.50	5.25	8
Dim. B	2.32	2.69	2.94	3.82	5.07
Dim. C	1" NPT	1 1/4" NPT	1 1/2" NPT	2" NPT	2 1/2" NPT

Fittings

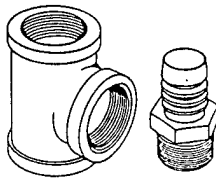

Pipe Size	1"	1 1/4"	1 1/2"	2"	2 1/2"
Tee	BA415	BA431	BA432	BA433	BA434
Common Elbow	BA220	BA244	BA230	BA247	BA248
Nipple	BA752	BA809	BA783	BA810	BA813
Plastic Male Pipe Hose Barb	AJ117A	AJ117B	-	-	-
Hose I.D.	1.25	1.25	-	-	-
Metal Male Pipe Hose Barb	AJ117D	AJ117F	AJ117C	AJ117G	AJ117H
Hose I.D.	1.00	1.25	1.50	2.50	3.00

Relief Valve

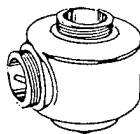

- Pressure/Vacuum Relief Valve, 1 1/2" NPT, Adjustable 30 – 170 in. H₂O, 200 cfm max.

Part #AG258

- Silencer for Relief Valve

Part #AJ121D

Pressure-Vacuum Gauge



- Pressure Gauge, Part #AJ496, 2 3/8" Dia., 1/4" NPT, 0-60 in. H₂O and 0-150 mbar
- Pressure Gauge, Part #AE133, 2 3/8" Dia., 1/4" NPT, 0-160 in. H₂O and 0-400 mbar
- Pressure Gauge, Part #AE133A, 2 3/8" Dia., 1/4" NPT, 0-200 in. H₂O
- Vacuum Gauge, Part #AJ497, 2 3/8" Dia., 1/4" NPT, 0-60 in. H₂O and 0-150 mbar
- Vacuum Gauge, Part #AE134, 2 3/8" Dia., 1/4" NPT, 0-160 in. H₂O and 0-400 mbar

ATTACHMENT B

APPENDIX B

APPENDIX B

GEOLOGIC LOGS AND CHAIN OF CUSTODY FORMS

Blows/Ft	PID (ppm)	ID#/Recov.	DEPTH (ft)	SAMPLES	SYMBOLS	MATERIALS DESCRIPTION
8/20/28	0.0	100%	5			SAND (SW): light yellowish brown (10 YR 6/4); coarse to fine grained, little silt; no odor.
28/50/ 50-4"	0.0	100% ED3MPA-10'	10	☒		SAND (SW): brown (10 YR 5/3); coarse to fine grained, little silt, little gravel; no odor.
15/31/ 50-5"	0.0	80%	15			SAND (SM): brown (10 YR 5/3); coarse to fine grained, some silt; more consolidated than soils above; no odor.
			20			Total depth of boring = 15 feet. No groundwater encountered during drilling.

PROJECT	Edwards Air Force Base	DRILLING COMPANY	Tonto Environmental Drilling
LOCATION	IRP Site 43, Near Building 1200	DATE DRILLED	09/08/93
JOB NUMBER	DE268.23.04	SURFACE ELEVATION	
GEOLOGIST	Chris Pluhar/Tom Blaney	TOTAL DEPTH OF HOLE	15 Feet
DRILL RIG	Hollow Stem Auger	WATER LEVEL	

Blows/Ft	PTD (ppm)	Recovery %	DEPTH (ft)	SAMPLES	SYMBOLS	MATERIALS DESCRIPTION
5/10/20	0.0	100%	5			SAND (fill): brown (10 YR 5/3); coarse to fine grained, little silt; no odor.
	12.2					Same as above, except strong odor and different color.
						Contamination extends from 6' to 9'.
22/26/33	0.0	100%	10			SAND (SM): pale brown (10 YR 6/3); coarse to fine grained, some silt; no odor.
26/74	0.0	50%	15			SAND (SM): pale brown (10 YR 6/3); coarse to fine grained, some silt; no odor.
						Total depth of boring = 15 feet. No groundwater encountered during drilling.

PROJECT	Edwards Air Force Base	DRILLING COMPANY	Tonto Environmental Drilling
LOCATION	IRP Site 43, Near Building 1200	DATE DRILLED	09/08/93
JOB NUMBER	DE268.23.04	SURFACE ELEVATION	
GEOLOGIST	Chris Pluhar/Tom Blaney	TOTAL DEPTH OF HOLE	15 Feet
DRILL RIG	Hollow Stem Auger	WATER LEVEL	

Blows/Ft	PIU (ppm)	Recovery %	DEPTH (ft)	SAMPLES	SYMBOLS	MATERIALS DESCRIPTION
10/17/17	0.0	100%	5			SAND (SW): brown (10 YR 5/3); coarse to fine grained, little silt; no odor.
18/23/35	0.0	100%	10			SAND (SM): pale brown (10 YR 6/3); coarse to fine grained; some silt.
<p><i>Total depth of boring = 10 feet. No groundwater encountered during drilling.</i></p>						

PROJECT <u>Edwards Air Force Base</u>	DRILLING COMPANY <u>Tonto Environmental Drilling</u>
LOCATION <u>IRP Site 43, Near Building 1200</u>	DATE DRILLED <u>09/08/93</u>
JOB NUMBER <u>DE268.23.04</u>	SURFACE ELEVATION _____
GEOLOGIST <u>Chris Pluhar</u>	TOTAL DEPTH OF HOLE <u>10 Feet</u>
DRILL RIG <u>Hollow Stem Auger</u>	WATER LEVEL _____

Blows/Ft	PID (ppm)	ID#/Recov.	DEPTH (ft)	SAMPLES	SYMBOLS	MATERIALS DESCRIPTION
						Contamination begins to appear; heavy staining.
7/11/93	8.1	ED3-VW-5' 100%	5	☒		SAND (SM): brown (10 YR 5/3); coarse to fine grained, some silt; some odor.
21/32/37	296	ED3-VW-10' 67%	10	☒		SAND (SM): same as above; strong odor, some staining.
9/23/50	60.1	ED3-VW-15' 67%	15	☒		SAND (SM): same as above; no odor, no staining. Total depth of boring = 15 feet. No groundwater encountered during drilling.
			20			

PROJECT	Edwards Air Force Base	DRILLING COMPANY	Tonto Environmental Drilling
LOCATION	IRP Site 43, Near Building 1200	DATE DRILLED	09/08/93
JOB NUMBER	DE268.23.04	SURFACE ELEVATION	
GEOLOGIST	Chris Pluhar/Tom Blaney	TOTAL DEPTH OF HOLE	15 Feet
DRILL RIG	Hollow Stem Auger	WATER LEVEL	

