

LOAN DOCUMENT

PHOTOGRAPH THIS SHEET

①

DTIC ACCESSION NUMBER

LEVEL

INVENTORY

2 Parts
Bioventing Pilot Test Work Plan for Site 13115
DOCUMENT IDENTIFICATION
Dec 94

DISTRIBUTION STATEMENT A
Approved for Public Release
Distribution Unlimited

DISTRIBUTION STATEMENT

ACCESSION FOR	
NTIS	GRAM <input checked="" type="checkbox"/>
DTIC	TRAC <input type="checkbox"/>
UNANNOUNCED	<input type="checkbox"/>
JUSTIFICATION	
BY	
DISTRIBUTION/	
AVAILABILITY CODES	
DISTRIBUTION	AVAILABILITY AND/OR SPECIAL
A-1	

DISTRIBUTION STAMP

DATE ACCESSIONED

DATE RETURNED

20001127 004

DATE RECEIVED IN DTIC

REGISTERED OR CERTIFIED NUMBER

PHOTOGRAPH THIS SHEET AND RETURN TO DTIC-FDAC

H
A
N
D
L
E

W
I
T
H

C
A
R
E

PART I

**Bioventing Pilot Test Work Plan for
Site 13115
Heating Oil UST Site
Marine Corps Base Camp Pendleton, California**

PART II

**Draft Bioventing Pilot Test Interim
Results Report for
Site 13115
Heating Oil UST Site
Marine Corps Base Camp Pendleton, California**

Prepared For

**Air Force Center for Environmental Excellence
Brooks AFB, Texas**

and

**ACS Environmental Security
MCB Camp Pendleton, California**

Parsons ES

Parsons Engineering Science, Inc.

December 1994

9404 Genesee Avenue, Suite 140
La Jolla, California 92037

DEFENSE TECHNICAL INFORMATION CENTER REQUEST FOR SCIENTIFIC AND TECHNICAL REPORTS

Title AFCEE Collection

1. Report Availability (Please check one box)

- This report is available. Complete sections 2a - 2f.
- This report is not available. Complete section 3.

2a. Number of Copies Forwarded

1 each

2b. Forwarding Date

July/2000

2c. Distribution Statement (Please check ONE box)

DoD Directive 5230.24, "Distribution Statements on Technical Documents," 18 Mar 87, contains seven distribution statements, as described briefly below. Technical documents MUST be assigned a distribution statement.

- DISTRIBUTION STATEMENT A: Approved for public release. Distribution is unlimited.
- DISTRIBUTION STATEMENT B: Distribution authorized to U.S. Government Agencies only.
- DISTRIBUTION STATEMENT C: Distribution authorized to U.S. Government Agencies and their contractors.
- DISTRIBUTION STATEMENT D: Distribution authorized to U.S. Department of Defense (DoD) and U.S. DoD contractors only.
- DISTRIBUTION STATEMENT E: Distribution authorized to U.S. Department of Defense (DoD) components only.
- DISTRIBUTION STATEMENT F: Further dissemination only as directed by the controlling DoD office indicated below or by higher authority.
- DISTRIBUTION STATEMENT X: Distribution authorized to U.S. Government agencies and private individuals or enterprises eligible to obtain export-controlled technical data in accordance with DoD Directive 5230.25, Withholding of Unclassified Technical Data from Public Disclosure, 6 Nov 84.

2d. Reason For the Above Distribution Statement (in accordance with DoD Directive 5230.24)

2e. Controlling Office

HQ AFCEE

2f. Date of Distribution Statement Determination

15 Nov 2000

3. This report is NOT forwarded for the following reasons. (Please check appropriate box)

- It was previously forwarded to DTIC on (date) and the AD number is
- It will be published at a later date. Enter approximate date if known.
- In accordance with the provisions of DoD Directive 3200.12, the requested document is not supplied because:

Print or Type Name
Laura Peña
Telephone
210-536-1431

Signature
Laura Peña

(For DTIC Use Only)
AQ Number M01-01-0348

PART I

**Bioventing Pilot Test Work Plan for
Site 13115
Heating Oil UST Site
Marine Corps Base Camp Pendleton, California**

PART II

**Draft Bioventing Pilot Test Interim
Results Report for
Site 13115
Heating Oil UST Site
Marine Corps Base Camp Pendleton, California**

Prepared For

**Air Force Center for Environmental Excellence
Brooks AFB, Texas**

and

**ACS Environmental Security
MCB Camp Pendleton, California**

Parsons ES

Parsons Engineering Science, Inc.

December 1994

9404 Genesee Avenue, Suite 140
La Jolla, California 92037

CONTENTS

PART I BIOVENTING PILOT TEST WORK PLAN SITE 13115 HEATING OIL UST MARINE CORPS BASE CAMP PENDLETON, CALIFORNIA

	Page
1.0 INTRODUCTION	I-1
2.0 SITE DESCRIPTION	
2.1 Site Location and History	I-3
2.2 Site Geology	I-3
2.3 Site Contaminants	I-3
3.0 SITE-SPECIFIC ACTIVITIES	I-6
3.1 Location and Construction of Vent Wells and Vapor Monitoring Points	I-6
3.2 Handling of Drill Cuttings	I-9
3.3 Soil and Soil Gas Sampling	I-9
3.3.1 Soil Samples	I-9
3.3.2 Soil Gas Samples	I-11
3.4 Blower System	I-11
3.5 <i>In-Situ</i> Respiration Test	I-11
3.6 Air Permeability Test	I-13
3.7 Air Emissions Monitoring	I-13
3.8 Installation of Extended (One-Year) Pilot Test Bioventing System	I-13
4.0 EXCEPTIONS TO PROTOCOL PROCEDURES	I-14
5.0 BASE SUPPORT REQUIREMENTS	I-14
6.0 PROJECT SCHEDULE	I-15
7.0 POINTS OF CONTACT	I-15
8.0 REFERENCES	I-16

FIGURES

Figure	Description	Page
1.1	MCB Camp Pendleton Location Map	I-2
2.1	Site Location Map and Proposed Vent Well/Vapor Monitoring Point Location, Site 13115 Heating Oil UST	I-4
2.2	Geological Cross section A-A, Site 13115 Heating Oil UST	I-5
3.1	Proposed Deep Air Injection Vent Well Construction Details, Site 13115 Heating Oil UST	I-7
3.2	Proposed Shallow Air Injection Vent Well Construction Details, Site 13115 Heating Oil UST	I-8
3.3	Proposed Monitoring Point Construction Details, Site 3115 Heating Oil UST	I-10
3.4	Blower System Instrumentation Diagram for Air Injection, Site 13115 Heating Oil UST	I-12

PART I

**BIOVENTING PILOT TEST WORK PLAN FOR
SITE 13115 HEATING OIL UST SITE
MARINE CORPS BASE CAMP PENDLETON, CALIFORNIA**

1.0 INTRODUCTION

This Pilot Test Work Plan presents the scope of an *in-situ* bioventing pilot test for the treatment of fuel-contaminated soils at the Building 13115 heating oil underground storage tank (UST) site, located in Area 13 on Marine Corp Base (MCB) Camp Pendleton. Camp Pendleton is located almost entirely in northern San Diego County (Figure 1.1), approximately halfway between Los Angeles and San Diego. MCB Camp Pendleton is located on the Pacific Coast between the cities of San Clemente (in southern Orange County) to the north, Oceanside to the south, and Fallbrook to the east. Constructed in 1942, the Base is primarily used for amphibious training. Other important Base activities include a Marine Corps Air Station and several artillery and bombing ranges. Background information on MCB Camp Pendleton and on Building 13115 is derived from *MCB Camp Pendleton, California, Underground Storage Tank Draft Site Assessment Report* (Jacobs Engineering, IT Corp., CH2M Hill. April 1993).

Bioventing tests have three primary objectives: (1) to assess the potential for supplying oxygen throughout the contaminated soil interval, (2) to determine the rate at which indigenous microorganisms will degrade fuel in the soil when stimulated by oxygen-rich soil gas, and (3) to evaluate the potential for sustaining these rates of biodegradation until fuel contamination is remediated to concentrations below regulatory standards.

The pilot test will be conducted in two phases. The initial pilot test phase will include installation of a vent well (VW) and three vapor monitoring points (MPs), followed by an *in-situ* respiration test and an air permeability test. The initial pilot test will determine important design parameters such as air permeability, radius of influence, biodegradation rates, and potential air emission quantities. It is anticipated that the duration of this initial testing will be approximately two weeks. If initial testing proves successful, an extended (one-year) testing phase will be initiated which will determine the longer term application of this remedial technology to degrade hydrocarbons at the site.

If bioventing is determined to be feasible at this site, pilot test data could be used to design and implement a full-scale remediation system (if necessary), and to estimate the time required for site cleanup. Since testing will take place within the



PARSONS ENGINEERING SCIENCE, INC. <small>OFFICES IN PRINCIPAL CITIES</small>  <small>9404 GENESEE AVENUE • SUITE 140 LA JOLLA, CA 92037 • (619) 453-9650</small>	DESIGNED BY:	FIGURE 1.1 MCB CAMP PENDLETON LOCATION MAP MCP CAMP PENDLETON, CALIFORNIA
	LD	
	DRAWN BY:	
	MSB	
	DATE:	
	12/12/94	

most contaminated soil at the site, an added benefit of pilot testing is that a significant amount of the fuel contamination should be biodegraded during the extended (one-year) pilot tests.

Additional background information on the development and recent success of bioventing technology is found in the *Test Plan and Technical Protocol for a Field Treatability Test for Bioventing* (Hinchee et. al., 1992). This protocol document will also serve as the primary reference for pilot test well designs and the detailed procedures which will be used during the tests.

2.0 SITE DESCRIPTION

2.1 Site Location and History

Building 13115 is located near the southern boundary of MCB Camp Pendleton in Area 13, west of Vandergrift Boulevard, approximately three miles north of the Vandergrift gate. This two story, former barracks now houses administrative offices. Constructed on concrete pilings, Building 13115 sits approximately two feet above the ground surface.

A 1,000-gallon, single-walled concrete bottle-neck UST was installed in 1943. The tank stores heating oil for the building's furnace. In October 1986, this tank failed an integrity test. In late 1991 and early 1992, site characterization activities were performed by IT Corporation. Characterization activities included drilling and sampling nine borings, which ranged in depth from 20 to 56 feet below the ground surface (bgs). Soil samples for laboratory analysis were collected at five-foot intervals. Groundwater was not encountered at the site. The location of the heating oil tank and previous site characterization borings are shown in Figure 2.1.

2.2 Site Geology

Soils encountered during previous investigations were very dense sands, silty and clayey sands, silt and clay of the Santiago formation which is part of the La Jolla Group (Jacobs Engineering et. al. 1993). The La Jolla Group ranges in composition from moderate deepwater fine grain siltstones to sandy beach and continental sandstone and conglomerate of middle Eocene age. A geologic cross section of the site is presented on Figure 2.2. The cross section was developed from the boring logs of previous investigations and from the cross sections contained in the Underground Storage Tank Draft Site Assessment Report.

2.3 Site Contamination

Site contamination consists of heating oil that leaked from the 1,000 gallon concrete UST or associated piping, which is still in use at the site. Soil samples collected during the site assessment were analyzed for total recoverable petroleum hydrocarbons (TRPH) by EPA 418.1 only. The sample from 19 feet bgs in boring B13115-3 had the highest TRPH concentration of 12,619 mg/kg. Soil sample locations and results are shown on Figure 2.2.

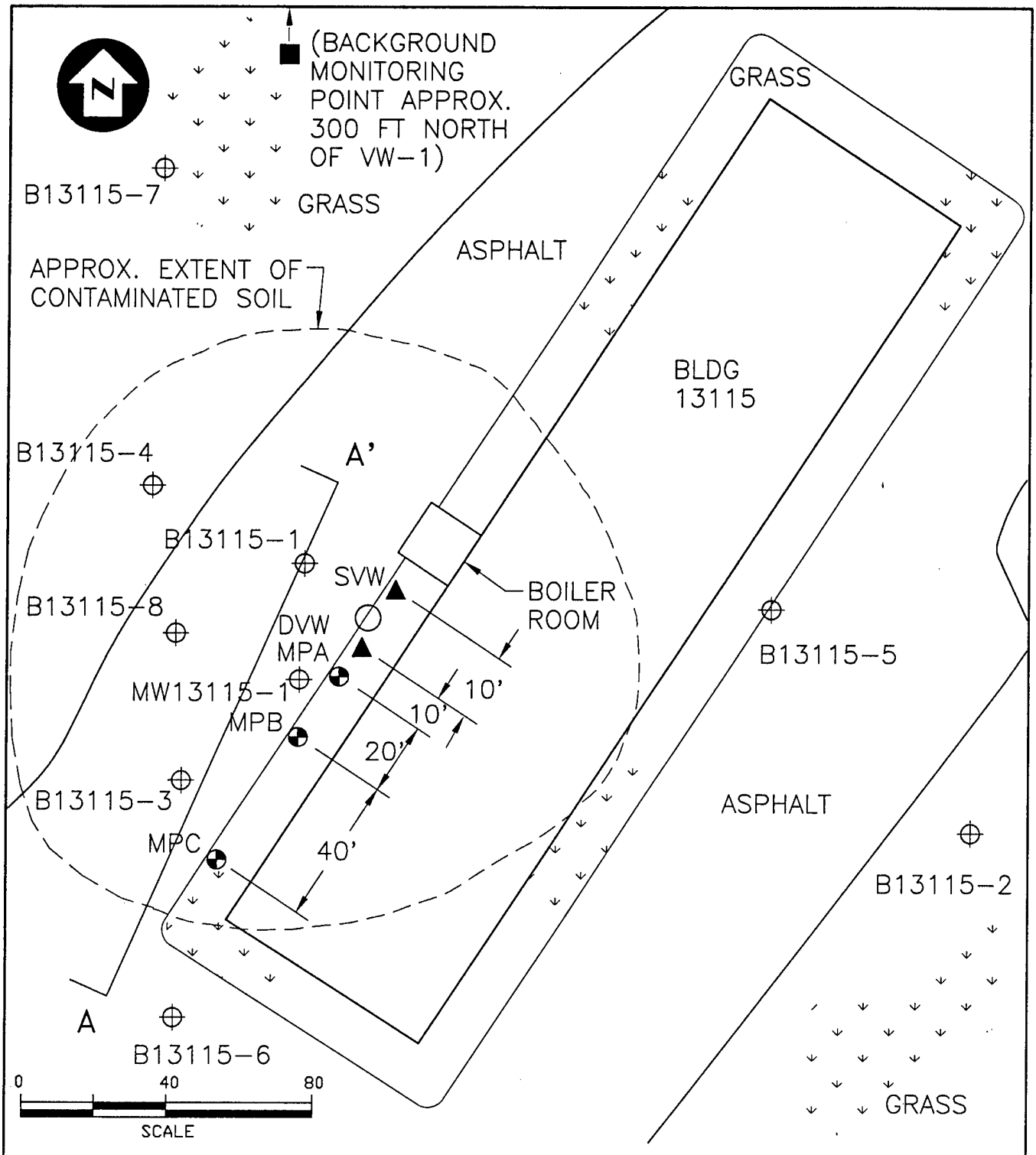

LEGEND

- ▲ PROPOSED DEEP & SHALLOW VENT WELL
- ⊕ EXISTING SOIL BORING
- ⊙ PROPOSED VAPOR MONITORING POINT
- 1000 GALLON HEATING OIL UST
- PROPOSED BACKGROUND MONITORING POINT
- A-A' CROSS SECTION

PARSONS ENGINEERING SCIENCE, INC.

OFFICES IN PRINCIPAL CITIES



9404 GENESEE AVENUE • SUITE 140
LA JOLLA, CA 92037 • (619) 453-9650

DESIGNED BY:

LD

DRAWN BY:

MSB

DATE:

12/13/94

FIGURE 2.1

SITE LOCATION MAP AND PROPOSED VENT
WELL/VAPOR MONITORING POINT LOCATION
SITE 13115 - HEATING OIL UST
MCB CAMP PENDLETON, CALIFORNIA

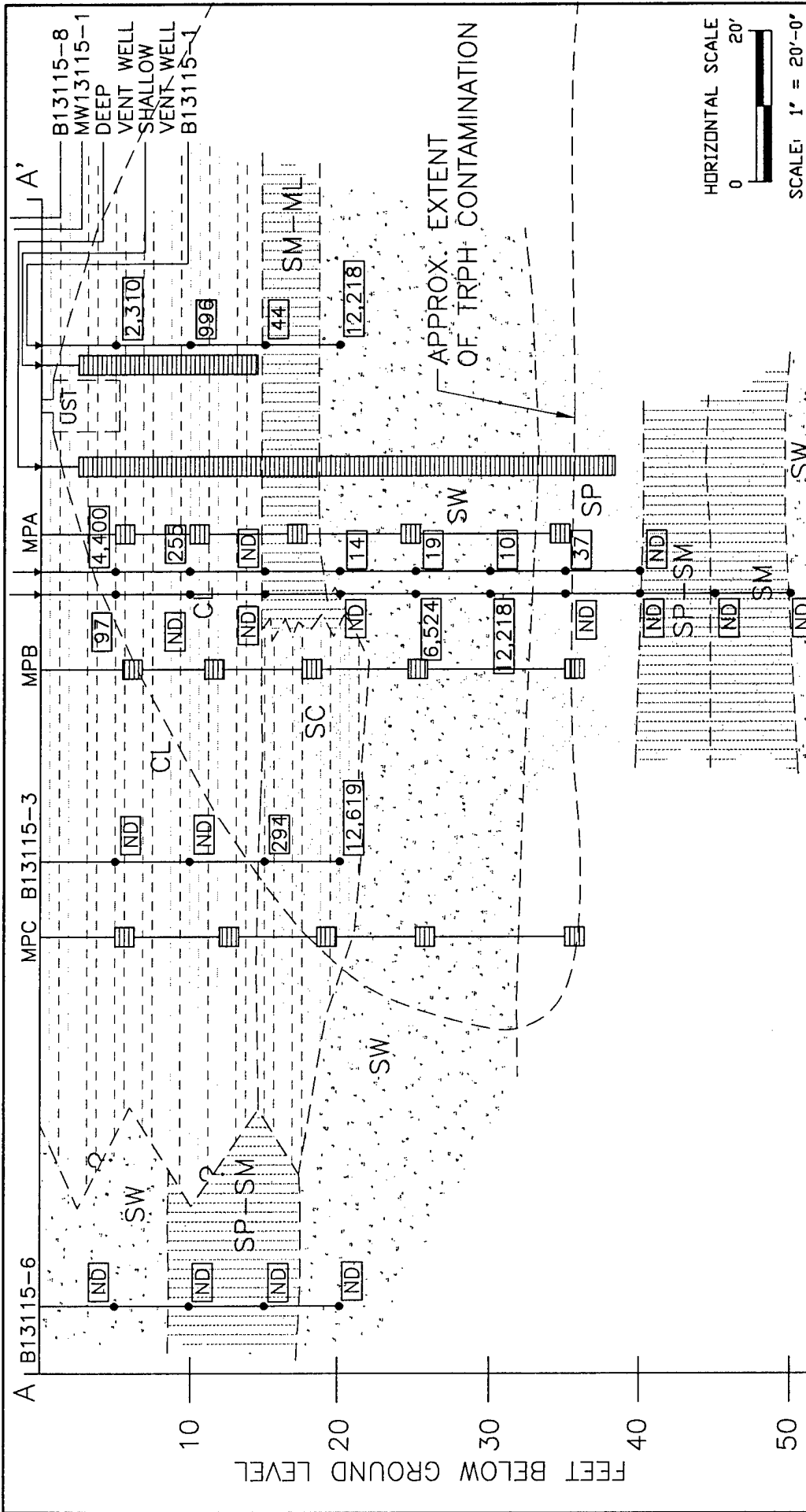

FIGURE 2.2
 GEOLOGIC CROSS SECTION A-A'
 SITE 13115 - HEATING OIL UST
 MCB CAMP PENDLETON, CALIFORNIA

DESIGNED BY:	LD
DRAWN BY:	MSB
DATE:	12/13/94

PARSONS ENGINEERING SCIENCE, INC.
 OFFICES IN PRINCIPAL CITIES

9404 GENESEE AVENUE • SUITE 140
 LA JOLLA, CA 92037 • (619) 453-9650

PARSONS

C:\CAD\722406\CAMPEN\FIG2-2DP.DWG CAD 4

3.0 SITE-SPECIFIC ACTIVITIES

The purpose of this section is to describe the bioventing test that will be performed by ES, at Building 13115. Activities at the site will include: (1) siting and construction of a central air injection VW system, and four vapor MPs; (2) an air permeability test; (3) an *in-situ* respiration test; and (4) the implementation of an extended (one-year) bioventing pilot test. Soil and soil gas sampling procedures are described below. In addition, the blower configuration that will be used to inject ambient air into contaminated soils through the VW is also discussed in this section. No dewatering or groundwater treatment will take place during the pilot test. Pilot test activities will be confined to the remediation of unsaturated soils.

3.1 Location and Construction of Vent Wells and Vapor Monitoring Points

A general description of criteria for siting a VW and MPs are included in the protocol document. Because of the site geology, a two well VW system will be constructed. Figure 2.1 and 2.2 indicate the proposed locations of the VW system and MPs at this site. The final locations of the VW system and MPs may vary slightly from the proposed locations if significant fuel contamination is not observed in the boring for the VWs. The VW system will be located in the area of highest detected fuel contamination (based on previous site investigation sampling data). This area is expected to have TPH concentration of up to 12,000 mg/kg. Soils in this area are expected to be oxygen-depleted (<2 percent O₂) and increased biological activity should be stimulated by oxygen-rich soil gas ventilation during extended pilot test operations.

Based on previous site characterization information, soil contamination extends radially, approximately 80 feet from the heating oil UST. The radius of venting influence in the sandier soil around the VW is estimated to be 60 feet. The venting radius in the clay near the surface will be somewhat less. Three MPs will be located within a 70 foot radius of the VW system in contaminated soil if possible. A fourth MP will be located approximately 300 feet north of the VW system. This background MP will be used to measure background levels of oxygen and carbon dioxide at the base, and to determine whether inorganic or natural carbon sources are contributing to oxygen uptake during the *in-situ* respiration test. Additional details of the *in-situ* respiration test are found in Section 5.7 of the protocol document.

A single vent well screened through the contaminated soil interval would direct most of the airflow through the sandier soil below 15 feet bgs. This would leave the majority of the clay from the ground surface to 15 feet bgs unaffected by air injection. To more effectively deliver oxygen through the clay, ES will use a 2 well VW system. One VW will be screened through the entire zone of soil contamination. A second VW will be screened through the clay only.

Construction diagrams for the VWs are shown in figures 3.1 and 3.2. A cross section of the VWs is shown on Figure 2.2. The VWs will be constructed of four-inch ID Schedule 40 PVC, with an interval of 0.04-inch slotted screen set at a depth of approximately six feet bgs or at the top of the contaminated soil interval. The screen of the deep VW will extend 36 feet to the base of contamination as determined by previous site characterization work. The screen of the shallow VW

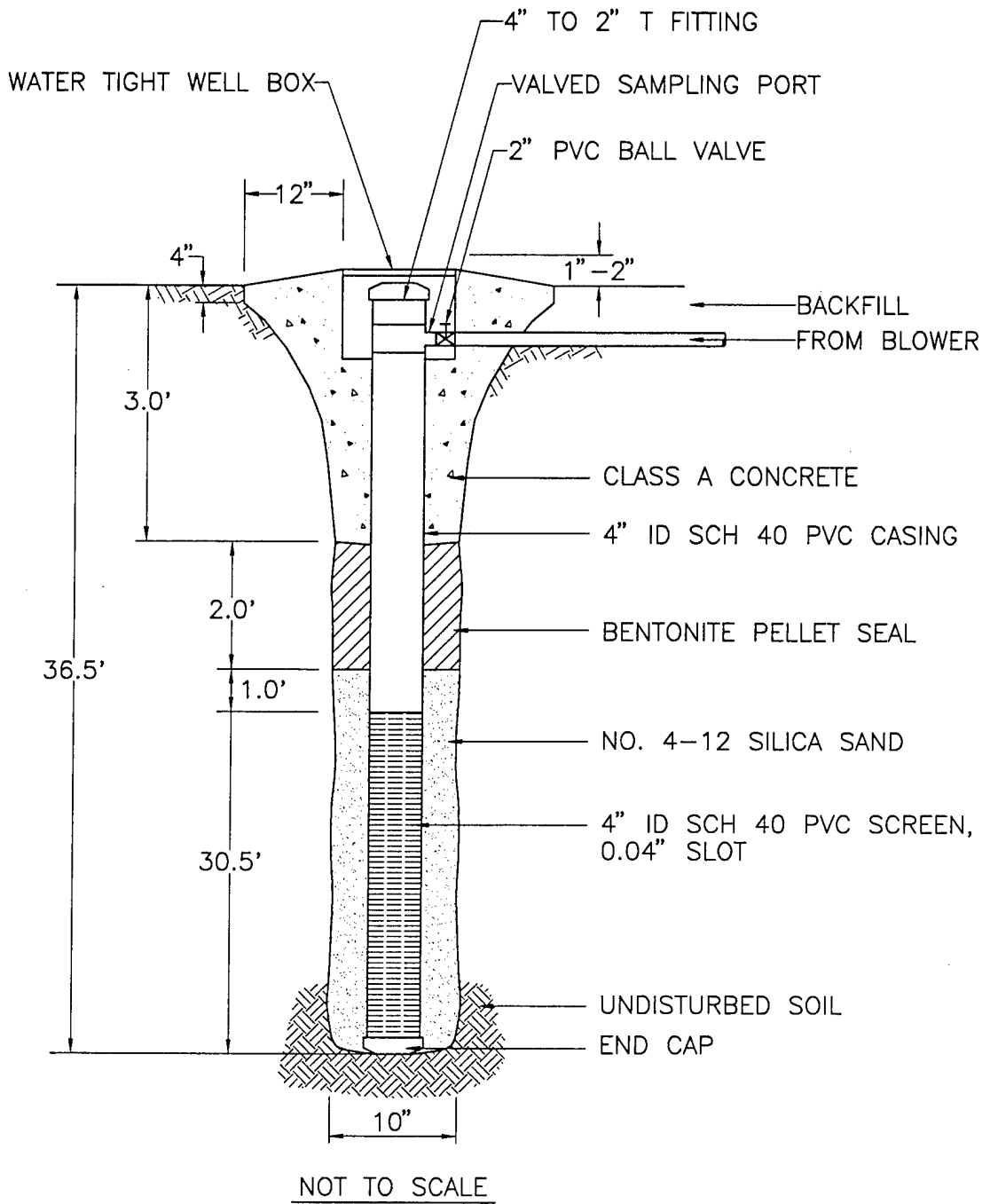

PARSONS ENGINEERING SCIENCE, INC.

OFFICES IN PRINCIPAL CITIES



9404 GENESEE AVENUE • SUITE 140
LA JOLLA, CA 92037 • (619) 453-9650

DESIGNED BY:

LD

DRAWN BY:

MSB

DATE:

12/13/94

FIGURE 3.1

PROPOSED DEEP AIR INJECTION
VENT WELL CONSTRUCTION DETAIL
SITE 13115 - HEATING OIL UST
MCB CAMP PENDLETON, CALIFORNIA

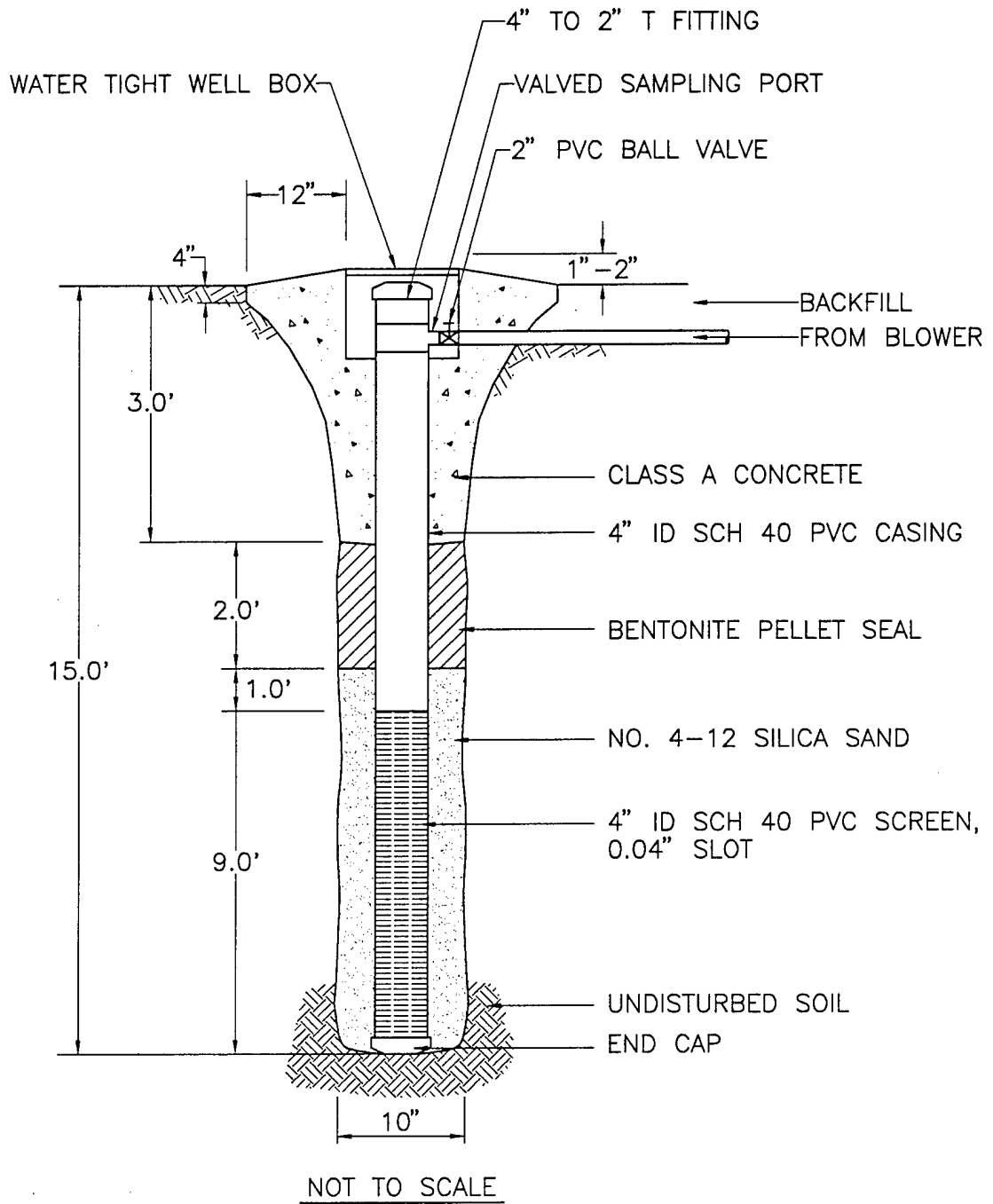

PARSONS ENGINEERING SCIENCE, INC.

OFFICES IN PRINCIPAL CITIES



9404 GENESEE AVENUE • SUITE 140
LA JOLLA, CA 92037 • (619) 453-9650

DESIGNED BY:

LD

DRAWN BY:

MSB

DATE:

12/13/94

FIGURE 3.2
PROPOSED SHALLOW AIR INJECTION
VENT WELL CONSTRUCTION DETAIL
SITE 13115 - HEATING OIL UST
MCB CAMP PENDLETON, CALIFORNIA

will extend to 15 feet bgs, the base of the clay. A GasTech™ Total Hydrocarbon Vapor Analyzer (THVA) will be used to collect field OVA readings for soil samples collected during drilling activities. This platinum catalyst combustion detector is calibrated with hexane, which provides a conservative reading representative of total volatile hydrocarbon (TVH) vapors present. Flush-threaded PVC casing and screen will be installed without using organic solvents or glues. The filter pack will consist of clean, 4-12 grain size (or equivalent) silica sand, and will be placed in the annular space of the screened interval. A two-foot-thick layer of bentonite pellets, hydrated in place with potable water, will be placed directly over the filter pack. This layer will prevent the Type A concrete from saturating the filter pack. The concrete will be tremied into the annular space above the bentonite pellets to a depth of one foot bgs, thus producing an air-tight seal above the screened interval. A complete seal is critical to prevent injected air from short-circuiting to the surface during the bioventing test.

A typical, multi-depth MP installation for this site is shown in Figure 3.3 and in Figure 2.2. Oxygen and carbon dioxide soil gas concentrations will be monitored via vapor monitoring screens placed at depth intervals of 6 feet, 12 feet, 18 feet, 25 feet and 35 feet bgs which correspond to the different soil types encountered during previous investigations. Multi-depth monitoring will assess whether the entire soil profile is receiving oxygen and will be used to measure fuel biodegradation rates at all monitored depths. The annular space between the vapor monitoring screen filter packs will be sealed with bentonite chips completely hydrated in place to isolate the monitoring intervals. As with the VWs, several inches of bentonite pellets will be used directly above and below the filter pack intervals for seals. In the vapor monitoring point closest to the VWs, thermocouples will be installed at the deepest and shallowest vapor monitoring screens to measure soil temperatures. Additional details on VW and MP construction are found in Section 4 of the protocol document.

3.2 Handling of Drill Cuttings

Drill cuttings will be collected in U.S. Department of Transportation (DOT) approved containers. These containers will be labeled, then placed in the area designated by the base point-of-contact. Final disposition of drill cuttings will be the responsibility of MCB Camp Pendleton, or their designated contractor.

3.3 Soil and Soil Gas Sampling

3.3.1 Soil Samples

Three soil samples will be collected from the pilot test area during the installation of the VW and MPs. Sampling procedures will follow those outlined in the protocol document. A total hydrocarbon vapor analyzer (THVA) will be used during drilling to screen soil samples for determining intervals of high fuel contamination. One sample will be collected from the most contaminated interval of each soil type. These soil samples will be analyzed for Total Recoverable Petroleum Hydrocarbons (TRPH); Benzene, Toluene, Ethylbenzene, and Xylenes (BTEX); and soil moisture, pH, grain-size distribution, alkalinity, total iron, and nutrients, including Total Kjeldahl Nitrogen (TKN) and total phosphorous.

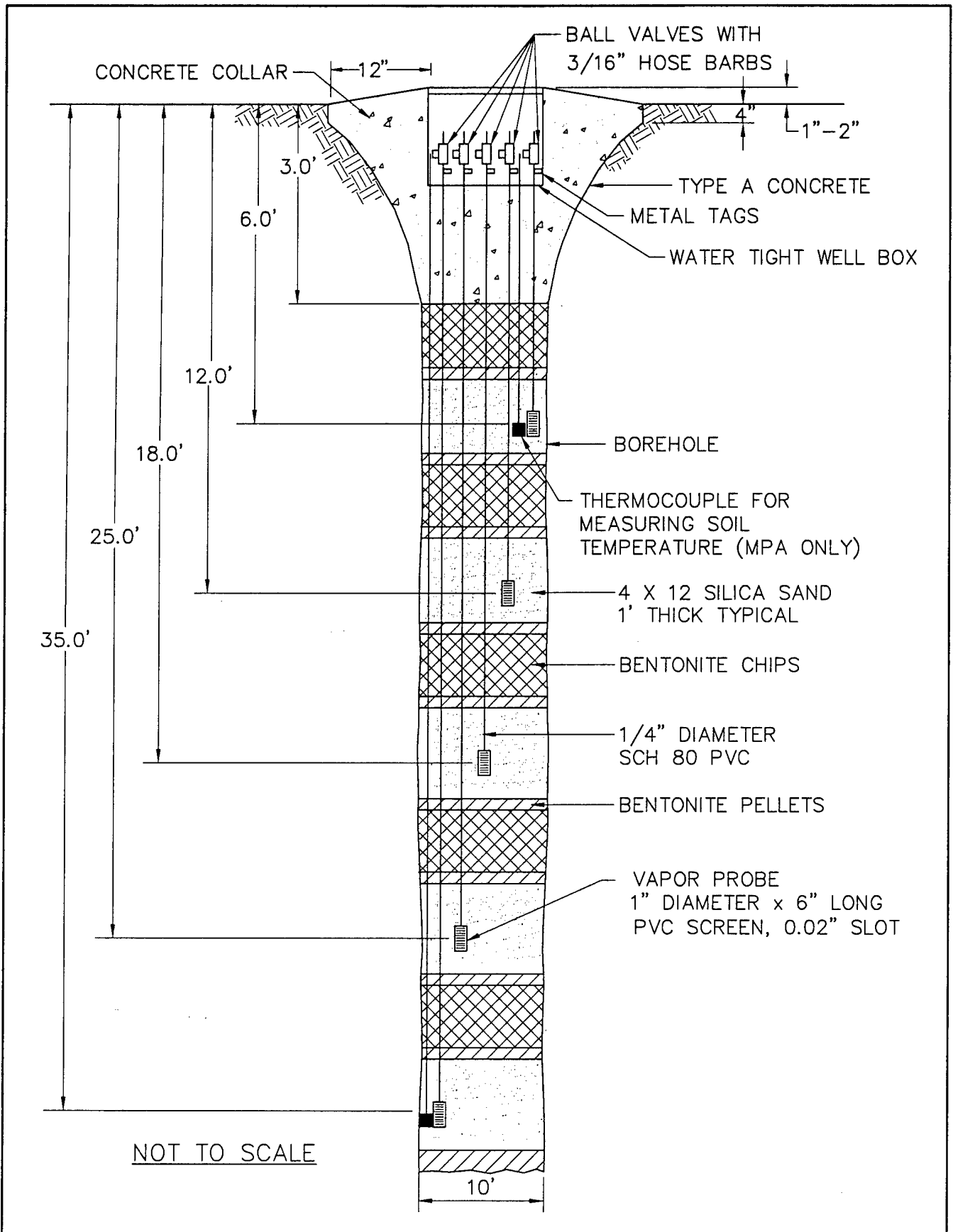

PARSONS ENGINEERING SCIENCE, INC.

OFFICES IN PRINCIPAL CITIES



9404 GENESEE AVENUE • SUITE 140
LA JOLLA, CA 92037 • (619) 453-9650

DESIGNED BY:

LD

DRAWN BY:

MSB

DATE:

12/13/94

FIGURE 3.3
PROPOSED MONITORING POINT
CONSTRUCTION DETAIL
SITE 13115 - HEATING OIL UST
MCB CAMP PENDLETON, CALIFORNIA

An additional soil sample will be collected from representative soils in the background MP and analyzed for Total Kjeldahl Nitrogen (TKN) in order to characterize the non-contaminated, baseline soil nutrient conditions.

Soil samples will be collected using a split-spoon sampler containing brass tube liners. Sample tube ends will be sealed with Teflon sheets and held in place by plastic caps. Soil samples will be labelled following the nomenclature specified in the Section 5 of the protocol document, wrapped in plastic, and placed in a cooler for shipment. A chain-of-custody form will be completed, and the cooler will be shipped to Pace Laboratory in Huntington Beach, California, for analysis. This laboratory has been audited by the Air Force and meets all quality assurance/quality control (QA/QC) and certification requirements for the State of California.

3.3.2 Soil Gas Samples

During the pilot test, initial soil gas samples will be collected in SUMMA canisters, in accordance with the Bioventing Field Sampling Plan (ES, 1992). These samples will be collected from the VW, and from the MPs closest to and furthest from the VW (i.e., MPA and MPC). The soil gas samples will be used to predict potential air emissions, to determine the reduction in BTEX and Total Volatile Hydrocarbons (TVH) during the one-year tests, and to detect any migration of these vapors from the source areas.

Soil gas sample canisters will be placed in a small cooler and packed with foam pellets to prevent excessive movement during shipment. In order to prevent condensation of hydrocarbons, samples will not be preserved on ice. A chain-of-custody form will be completed, and the cooler will be shipped to the Air Toxics, Inc., laboratory in Folsom, California, where the samples will be analyzed by EPA method TO-3.

3.4 Blower Systems

A 1-horse power regenerative blower, capable of injecting 50 standard cubic feet per minute (scfm) at 40 inches of water will be used to conduct the initial air permeability test.



A schematic diagram of a typical air injection system used for pilot testing is shown on Figure 3.4. The maximum power requirement anticipated for this pilot test is 230-volt, single-phase, 30-amp service. Additional power supply requirement details are described in Section 5.0, Base Support Requirements.

3.5 In-Situ Respiration Tests

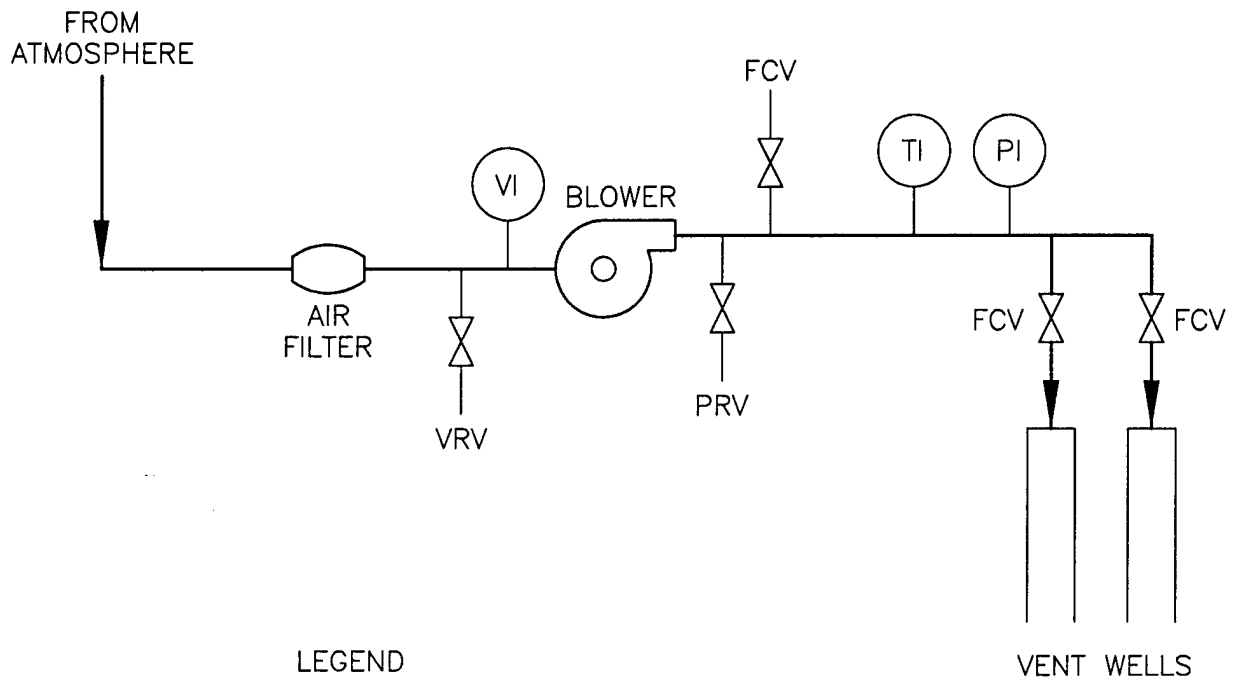
The objective of *in-situ* respiration tests is to determine the rate at which soil bacteria degrade petroleum hydrocarbons in the presence of oxygen. Respiration tests will be performed at MP screens, where bacterial biodegradation of hydrocarbons is indicated by low oxygen levels and elevated carbon dioxide concentrations in the soil gas. The test will be conducted in the MP screens with the highest TVH levels and lowest oxygen levels. Small 1 scfm pumps will inject air into selected MP screen intervals containing low oxygen levels (<2%). A 20-hour air injection period will be used to oxygenate local contaminated soils. At the end of the 20-hour air injection period, the air supply will be cut off, and oxygen and



LEGEND

-  PRESSURE INDICATOR
-  TEMPERATURE INDICATOR
-  VACUUM INDICATOR
- FCV FLOW CONTROL VALVE
- FRV PRESSURE RELIEF VALVE
- VRV VACUUM RELIEF VALVE

PARSONS ENGINEERING SCIENCE, INC.

OFFICES IN PRINCIPAL CITIES



9404 GENESEE AVENUE • SUITE 140
LA JOLLA, CA 92037 • (619) 453-9650

DESIGNED BY:

LD

DRAWN BY:

MSB

DATE:

12/13/94

FIGURE 3.4
BLOWER SYSTEM
INSTRUMENTATION DIAGRAM FOR AIR INJECTION
SITE 13115 – HEATING OIL UST
MCB CAMP PENDLETON, CALIFORNIA

carbon dioxide levels will be monitored for the following 48 to 72 hours. The decline in oxygen concentrations over time will be used to estimate rates of bacterial degradation of fuel residuals. Helium, an inert gas, will be injected at a concentration to two to four percent into every MP screen that is being used for respiration testing. The helium will be used as a tracer gas and levels will be monitored during the respiration test to identify possible system leaks or short circuits to the surface. Additional details on the *in-situ* respiration test are found in Section 5.7 of the protocol document

3.6 Air Permeability Tests

The objective of air permeability tests is to determine the areal extent of the subsurface soils (radius of influence) that can be oxygenated using one air injection VW. Air will be injected into the deep VW using a 1-horse power blower unit. Pressure response will be measured for 4 to 6 hours at each MP with differential pressure gauges to determine the regional influenced by the unit. Oxygen will also be monitored in the MPs over a period of 20 hours to verify that oxygen levels in the soil increase as the result of air injection. If, after 20 hours, oxygen levels in the clay do not increase, air flow from the blower will be diverted from the deep VW to the shallow VW soil. Oxygen concentrations will be monitored over the next few days and flow rates will be adjusted accordingly to ensure sufficient oxygen is being delivered through both clay and sandier soils.

3.7 Air Emissions Monitoring

Soil gas will not be extracted from the site during either the initial or extended pilot test. The proposed bioventing system will use a low rate (<30 scfm) of air injection to provide oxygen for enhanced biodegradation. Because these soils are contaminated with low-volatility heating oil, the potential for volatile emissions is very low. Because horizontal permeability is generally greater than vertical permeability, the injected air will tend to move outward rather than upward. This will promote *in-situ* biodegradation of fuel vapor as it moves slowly outward from the center of the spill.

If some upward movement of injected air does occur, it will be highest during the first day of air injection when the initial soil gas volume is displaced. ES will carefully monitor the air in the breathing zone during the first day of testing. A photoionization detector (PID) will be used to detect any emissions exceeding ambient conditions. The PID will be calibrated with isobutylene to detect BTEX compounds at the 1 ppmv level. This level of detection is consistent with the most conservative OSHA standards. Any sustained PID reading in excess of 1 ppmv will require an immediate reduction in air injection rates.

3.8 Installation of Extended (One-Year) Pilot Test Bioventing System

The extended (one-year) bioventing pilot test system will be installed at Building 13115 UST site if the initial pilot tests successfully demonstrate the feasibility of providing oxygen throughout the contaminated soil profile. Continued air injection would determine the long-term radius of oxygen influence, and the effects of time, available nutrients, and changing temperatures on fuel biodegradation rates. As part of extended pilot test systems, a fixed blower unit will be installed in the boiler room

located near the heating oil UST. A 2-inch diameter PVC pipe will be buried approximately 6 inches underground and will run from the blower to the vent well. The blower will deliver air to the vent wells at a total flow rate of approximately 30 scfm. A system will be operated for one year. Every six months, ES personnel will conduct *in-situ* respiration tests to monitor the long-term performance of the bioventing system. In addition, subsurface soil and soil gas samples will be collected after one year at locations as close as possible to the original MP/VW soil and soil gas sample locations in order to assess the degree of remediation achieved during the first year of *in-situ* treatment. Weekly system checks will be performed by MCB Camp Pendleton personnel. If required, major maintenance of the blower unit will be performed by ES San Diego personnel. Detailed blower system information, and a maintenance schedule, will be included in the operation and maintenance (O&M) manual provided to the base. More detailed information regarding the test procedures are included in the protocol document.

4.0 EXCEPTIONS TO PROTOCOL PROCEDURES

Procedures used to construct MP and VWs, measure soil permeability to air, and measure *in-situ* respiration rates, are described in Sections 4 and 5, respectively, of the protocol document. An expected exception to the protocol document is the use of two VWs.

5.0 BASE SUPPORT REQUIREMENTS

To prevent further site contamination, ES recommends the base pump out the heating oil from the UST immediately.

The following base support is needed prior to arrival of the drilling subcontractor and the ES pilot test team:

- Coordinating this work plan with local regulatory agencies and advising if any additional permits or information are required.
- Obtaining a base digging permit.
- Confirmation of an available power source, and the installation of a 230-volt, 30-amp, single-phase breaker box with one 230-volt receptacle and two 110-volt receptacles located in or near the boiler room.
- Provision of any paperwork required to obtain gate passes and security badges for approximately three ES employees, three drillers, and an electrician (if a base electrician is not available). Vehicle passes will be needed for approximately three to four vehicles.
- Provision of keys to the boiler room.

During initial testing, the following base support is needed:

- Acceptance of responsibility for drill cuttings from VW and MP borings, including any drum sampling to determine hazardous waste status. (If ES transfers custody of drums to another contractor working on the base, assistance in arranging this transfer will also be needed).

During the one-year extended pilot tests, base personnel will be required to perform the following activities:

- Check the blower system once per week to ensure that it is operating, and to record the air injection pressure and temperature, and to change the air filter as needed. ES will provide a brief training session for this procedure and a maintenance procedures manual with data collection sheets.
- If the blower stops working, notify: Mr. Larry Dudus of ES San Diego at (619) 453-9650, Mr. Chris Pluhar of ES Pasadena at (818) 585-6324, or Mr. Patrick Haas of AFCEE at (210) 536-4314.
- Arrange site access for an ES technician to conduct *in-situ* respiration tests approximately six months and one year after the initial pilot test.

6.0 PROJECT SCHEDULE

The following schedule is contingent upon approval of this pilot test work plan and completion of base support requirements.

<u>Event</u>	<u>Date</u>
Draft Pilot Test Work Plan to AFCEE MCB Camp Pendleton	July 6, 1994
Approval to Proceed	August 25, 1994
Begin Initial Pilot Test	September 8, 1994
Interim Results Report	December, 1994
Respiration Test	February 1995
Final Respiration Test and Soil Sampling	October 1995

7.0 POINTS OF CONTACT

Mr. Tom DeCosta
ACS Environmental Security
Bldg 22165 Box 555008
Camp Pendleton, CA 92055-5008
(619) 725-9742

Mr. Patrick Haas
AFCEE/ERT
8001 Arnold Dr.
Brooks AFB, TX 78235-5325
(210)536-4314 FAX (210) 536-4330

Mr. Larry Dudus
Parsons Engineering Science, Inc.
9404 Genesee Ave., Suite 140
La Jolla, CA 92037
(619) 453-9650
FAX (619) 453-9652

Mr. Doug Downey
Parsons Engineering Science, Inc.
1700 Broadway, Suite 900
Denver, CO 80290
(303) 831-8100
FAX (303) 831-8208

8.0 REFERENCES

Engineering-Science, Inc., 1992. *Field Sampling Plan for AFCEE Bioventing*, Denver, Colorado.

Hinchee, R.E., Ong, S.K., Miller, R.N., Downey, D.C., Frandt, R., January 1992. *Test Plan and Technical Protocol for a Field Treatability Test for Bioventing*.

Jacobs Engineering, IT Corp. CH2M Hill, April 1993. *MCB Camp Pendleton, California underground storage tank draft site assessment report*.

CONTENTS

PART II

DRAFT BIOVENTING PILOT TEST INTERIM TEST RESULTS REPORT SITE 13115 HEATING OIL UST MARINE CORPS BASE CAMP PENDLETON, CALIFORNIA

	Page
1.0 INTRODUCTION	II-1
2.0 SITE 13115 HEATING OIL UST	II-1
2.1 Pilot Test Design and Construction	II-1
2.1.1 Air Injection Vent Well	II-1
2.1.2 Monitoring Points	II-6
2.1.3 Blower Unit	II-6
2.2 Soil and Soil Gas Sampling Results	II-10
2.2.1 Soil Sampling Results	II-10
2.2.2 Soil Gas Sampling Results	II-10
2.3 Pilot Test Results	II-12
2.3.1 Exceptions to Test Protocol Procedures	II-12
2.3.2 Initial Soil Gas Chemistry	II-12
2.3.3 <i>In-Situ</i> Respiration Rates	II-12
2.3.4 Air Permeability	II-18
2.3.5 Oxygen Influence	II-20
2.3.6 Potential Air Emissions	II-20
2.4 Recommendations	II-21
3.0 REFERENCES	II-22
APPENDIX A O&M MANUAL	
APPENDIX B GEOLOGIC BORING LOGS AND CHAIN-OF-CUSTODY FORMS	

CONTENTS

PART II

DRAFT BIOVENTING PILOT TEST INTERIM TEST RESULTS REPORT SITE 13115 HEATING OIL UST MARINE CORPS BASE CAMP PENDLETON, CALIFORNIA

	Page
1.0 INTRODUCTION	II-1
2.0 SITE 13115 HEATING OIL UST	II-1
2.1 Pilot Test Design and Construction	II-1
2.1.1 Air Injection Vent Well	II-1
2.1.2 Monitoring Points	II-6
2.1.3 Blower Unit	II-6
2.2 Soil and Soil Gas Sampling Results	II-10
2.2.1 Soil Sampling Results	II-10
2.2.2 Soil Gas Sampling Results	II-10
2.3 Pilot Test Results	II-12
2.3.1 Exceptions to Test Protocol Procedures	II-12
2.3.2 Initial Soil Gas Chemistry	II-12
2.3.3 <i>In-Situ</i> Respiration Rates	II-13
2.3.4 Air Permeability	II-14
2.3.5 Oxygen Influence	II-14
2.3.6 Potential Air Emissions	II-20
2.4 Recommendations	II-22
3.0 REFERENCES	II-23
APPENDIX A O&M MANUAL	
APPENDIX B GEOLOGIC BORING LOGS AND CHAIN-OF-CUSTODY FORMS	

FIGURES

Figure	Description	Page
2.1	Record Drawing, Vent Well/Vapor Monitoring Point Locations, Site 13115 Heating Oil UST	II-2
2.2	Geologic Cross Section A-A, Site 13115 Heating Oil UST	II-3
2.3	Record Drawing, Deep Air Injection Vent Well - VW1 Construction Details, Site 13115 Heating Oil UST	II-4
2.4	Record Drawing, Shallow Air Injection Vent Well - VW2 Construction Details, Site 13115 Heating Oil UST	II-5
2.5	Record Drawing Blower and Piping System Diagram, Site 13115 Heating Oil UST	II-7
2.6	Record Drawing, Monitoring Point Construction Details, Site 13115 Heating Oil UST	II-8
2.7	Blower System Instrumentation Diagram for Air Injection, Site 13115 Heating Oil UST	II-9
2.8	Respiration Test CP1-VW1, Site 13115 Heating Oil UST	II-15
2.9	Respiration Test CP1-VW2, Site 13115 Heating Oil UST	II-16
2.10	Respiration Test CP1-MPA-16, Site 13115 Heating Oil UST	II-17
2.11	Respiration Test CP1-MPA-23, Site 13115 Heating Oil UST	II-18
2.12	Respiration Test CP1-MPA-30, Site 13115 Heating Oil UST	II-19

TABLES

Table	Description	Page
2.1	Soil and Soil Gas Laboratory Analytical Results, Site 13115 Heating Oil UST	II-11
2.2	Initial Soil Gas Chemistry, Site 13115 Heating Oil UST	II-13
2.3	Oxygen Utilization Rates, Site 13115 Heating Oil UST	II-20
2.4	Pressure Response (inches of water) During Air Permeability, Site 13115 Heating Oil UST	II-21
2.5	Influence of Air Injection Vent Well on Monitoring Point Oxygen Levels, Site 13115 Heating Oil UST	II-22

PART II

DRAFT

BIOVENTING PILOT TEST INTERIM RESULTS REPORT SITE 13115 HEATING OIL UST MARINE CORPS BASE CAMP PENDLETON, CALIFORNIA

1.0 INTRODUCTION

The purpose of this Part II report is to describe the results of the initial pilot test at Building 13115 and to make specific recommendations for extended testing which will determine the long-term impact of bioventing on site contamination. A description of the site history and contaminants detected during previous investigations is described in Part I, the Bioventing Pilot Test Work Plan.

2.0 SITE 13115 HEATING OIL UST

At the time the Bioventing Pilot Test Work Plan was written, the leaking heating oil UST at Building 13115 was still in service. The UST has since been emptied, locked, and is no longer in service. Fuel for the boiler is currently being supplied by an aboveground tank located north of the boiler room.

2.1 Pilot Test Design and Construction

Installation of two air injection vent wells (VW1 and VW2) and four vapor monitoring points (MPs) at Building 13115 (designated CP1) was completed on September 9, 1994. Drilling services were provided by California Pacific Drilling of Moreno Valley, California. Well installation and soil sampling were directed by Parsons Engineering Science, Inc. (Parsons ES) geologists Mr. Larry Dudus and Mr. Christer Loftenius. The following sections describe the design and installation of the bioventing pilot test system at this site.

Two VWs (CP1-VW1 and CP1-VW2), four MPs (CP1-MPA, CP1-MPB, CP1-MPC, and CP1-MPBG) and a blower unit were installed at the site. Figures 2.1 and 2.2, respectively, depict the location of, and a geologic cross section for, the VWs and MPs completed at the site. The background MP (CP1-MPBG) was installed approximately 400 feet northeast of the site.

2.1.1 Air Injection Vent Well

An air injection vent well (CP1-VW1) was installed following procedures described in the Air Force Center for Environmental Excellence (AFCEE) bioventing protocol document (Hinchee et. al., 1992). Previous site characterizations detected the presence of a silt and clay layer from ground surface to approximately 15 feet below ground surface (bgs). To help insure adequate air flow through this silty clay layer, an additional well (CP1-VW2) was installed. Well CP1-VW2 is screened through the silty clay layer only. Figures 2.3 and 2.4 show construction details for CP1-VW1 and CP1-VW2, respectively.

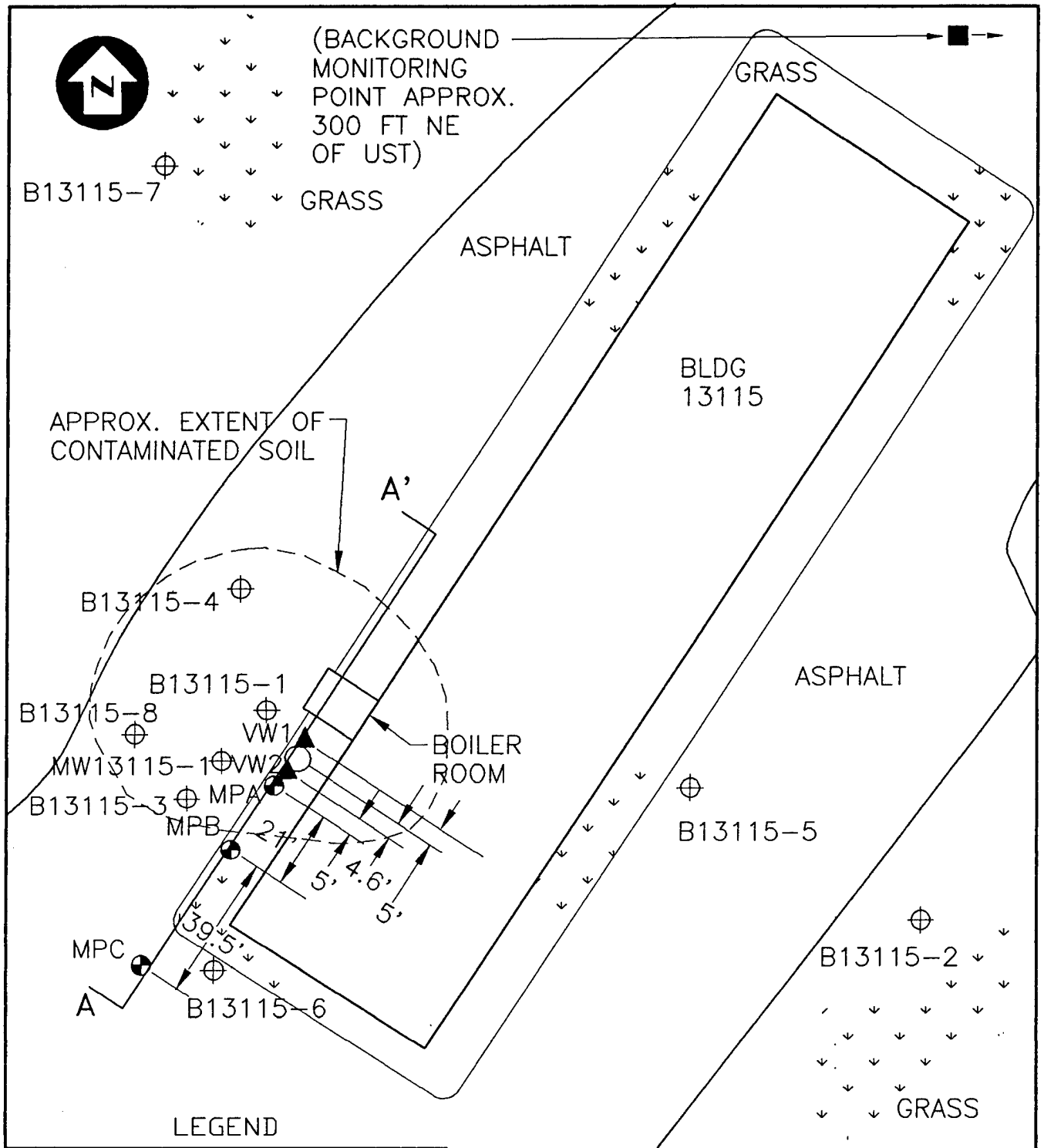

- LEGEND**
- ▲ VENT WELL
 - ⊕ VAPOR MONITORING POINT
 - BACKGROUND MONITORING POINT
 - ⊙ EXISTING SOIL BORING
 - 1000 GALLON HEATING OIL UST
 - A-A' CROSS SECTION

PARSONS ENGINEERING SCIENCE, INC.
 OFFICES IN PRINCIPAL CITIES

PARSONS 9404 GENESEE AVENUE • SUITE 140
 LA JOLLA, CA 92037 • (619) 453-9650

DESIGNED BY:
LD

DRAWN BY:
MSB

DATE:
12/14/94

FIGURE 2.1
RECORD DRAWING VENT WELL/VAPOR
MONITORING POINT LOCATIONS
SITE 13115 - HEATING OIL UST
MCB CAMP PENDLETON, CALIFORNIA

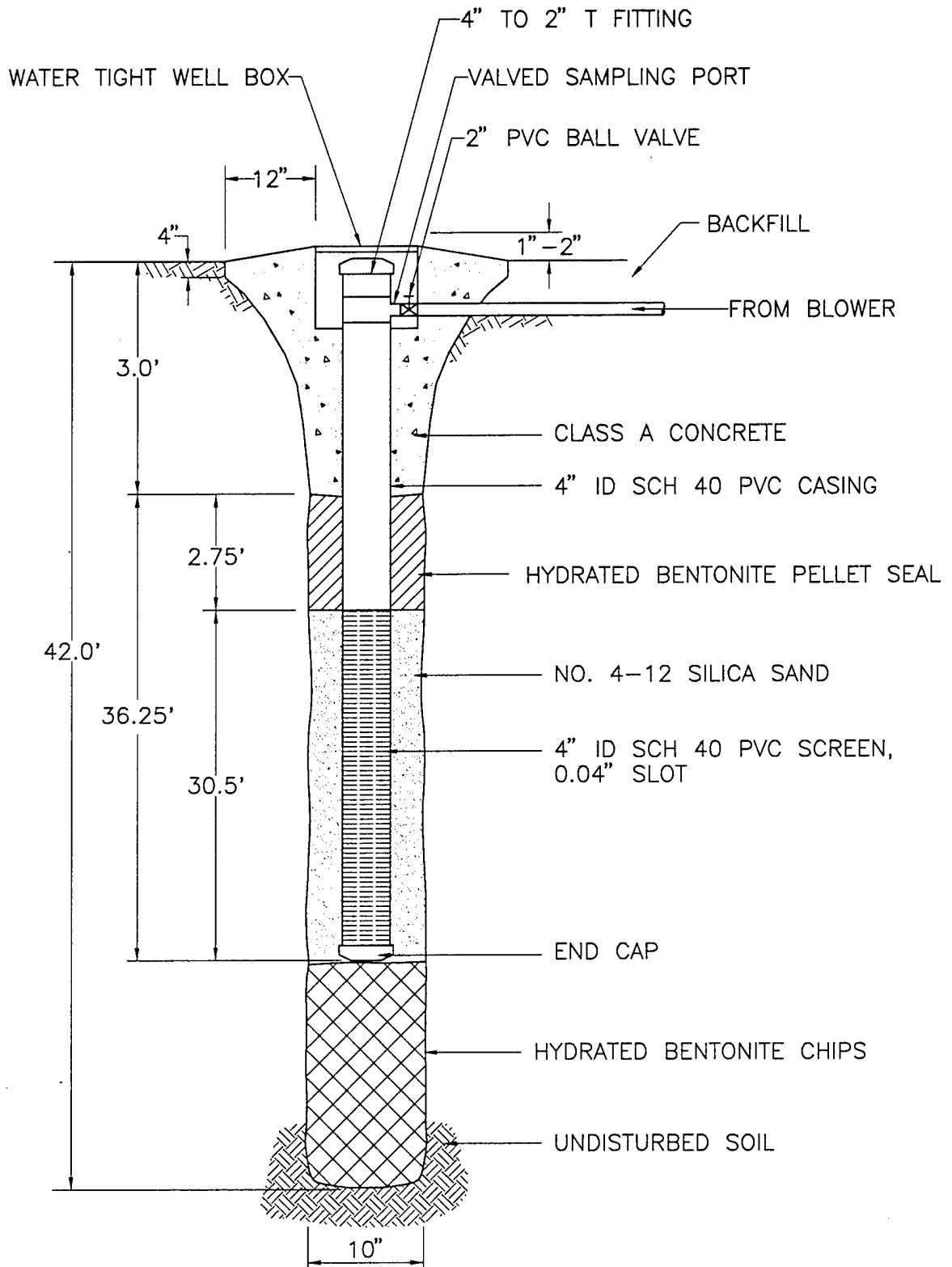

PARSONS ENGINEERING SCIENCE, INC.

OFFICES IN PRINCIPAL CITIES



9404 GENESEE AVENUE • SUITE 140
LA JOLLA, CA 92037 • (619) 453-9650

DESIGNED BY:

LD

DRAWN BY:

MSB

DATE:

12/14/94

FIGURE 2.3
RECORD DRAWING DEEP AIR INJECTION
VENT WELL-VW1 CONSTRUCTION DETAILS
SITE 13115 - HEATING OIL UST
MCB CAMP PENDLETON, CALIFORNIA

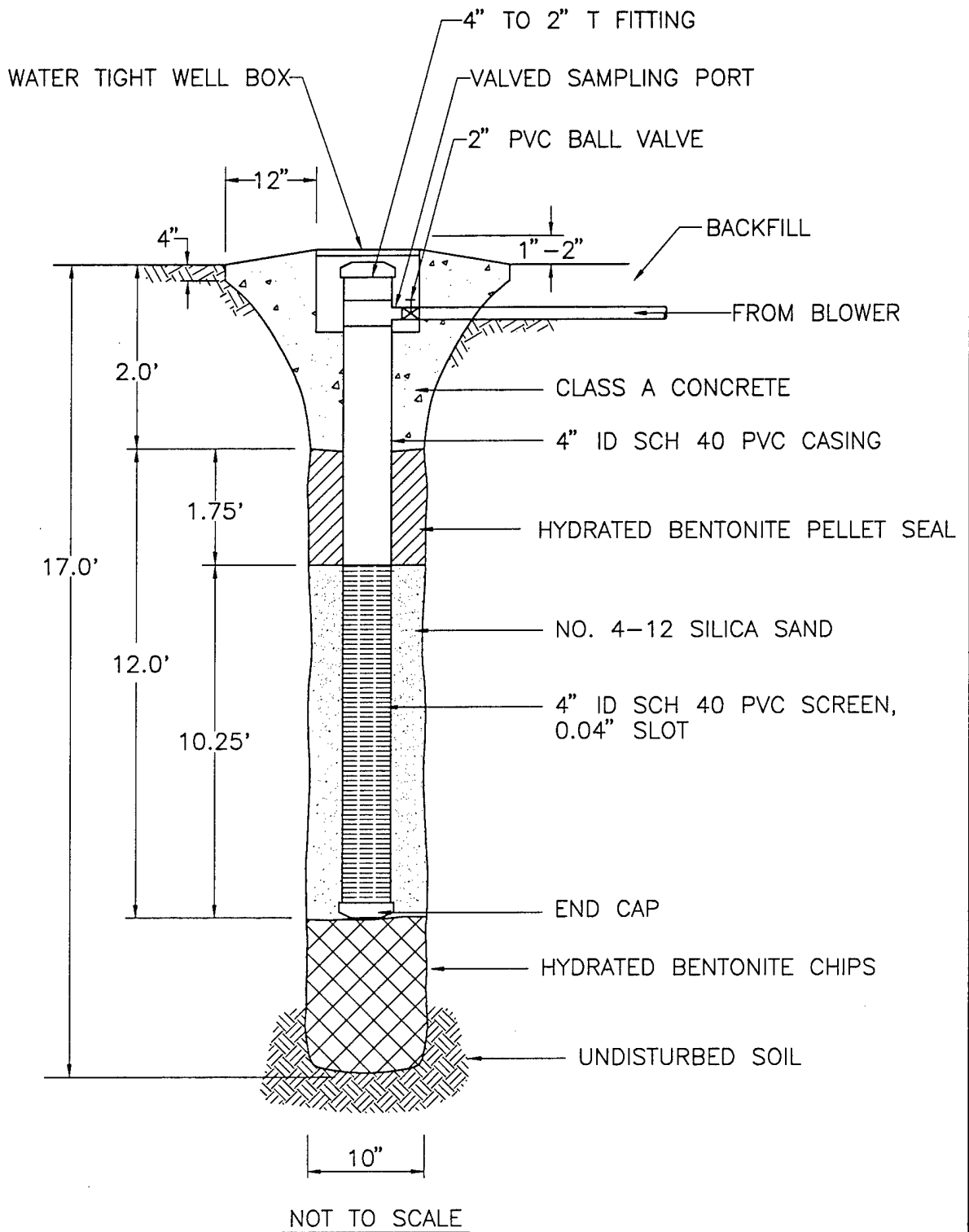

PARSONS ENGINEERING SCIENCE, INC.

OFFICES IN PRINCIPAL CITIES



9404 GENESEE AVENUE • SUITE 140
LA JOLLA, CA 92037 • (619) 453-9650

DESIGNED BY:

LD

DRAWN BY:

MSB

DATE:

12/14/94

FIGURE 2.4

RECORD DRAWING SHALLOW AIR INJECTION
VENT WELL-VW2 CONSTRUCTION DETAILS
SITE 13115 - HEATING OIL UST
MCB CAMP PENDLETON, CALIFORNIA

The VWs were located as close to the center of contamination as possible without risking damage during UST removal which is planned in the near future. The VWs were constructed using 4-inch diameter Schedule 40 polyvinyl chloride (PVC) casings with 0.04-inch slotted PVC screen. The screen in CP1-VW1 was installed from 5.9 to 35.9 feet bgs. The screen in CP1-VW2 was installed from 4 to 14 feet bgs. The annular spaces between the well screen and borehole were filled with 4 x 12 silica sand. Bentonite pellets were placed above the sand and hydrated in place. The top of the wells were completed with flush-mounted metal well vaults set in concrete pads designed in accordance with San Diego County requirements.

The well casing tops were finished with 4-inch by 2-inch PVC T fittings. The fittings were attached to 2-inch diameter Schedule 40 PVC pipe. Inside the well vaults, PVC ball valves were installed in the 2-inch pipe just after the T fittings. Small-valved sampling ports were installed between the ball valves and each of the well heads. The 2-inch PVC pipe was installed underground and extends from the well heads to a valve box located next to the stairs behind Building 13115 (Figure 2.5). From the valve box, a single 2-inch PVC pipe continues above ground under the stairs and into the boiler room where the blower is housed. The PVC pipe is connected to a galvanized steel pipe at the blower with a rubber Fernco® connector.

2.1.2 Monitoring Points

Screens for CP1-MPA, CP1-MPB, and CP1-MPC were installed at 7, 16, 23, and 30 feet bgs. The MPs were located 14.6, 35.6, and 74.1 feet away from CP1-VW1, respectively. Screen intervals for the background MP were installed at 7, 13, 20, and 27 feet bgs. These intervals differed from the other three MPs to correspond closely with site lithology. The background MP was located approximately 300 feet northeast of CP1-VW1. The MPs were constructed as shown in Figures 2.2 and 2.6. Each MP monitoring interval was constructed using a 6-inch section of 1-inch diameter 0.02-inch slotted PVC well screen and a 0.25-inch diameter Schedule 80 PVC riser pipe extending to the ground surface. At the top of each riser, a ball valve and a 3/16-inch hose barb were installed. The top of each MP was completed with a flush-mounted metal well vault set in a concrete base. Thermocouples were installed at the 7- and 30-foot depths at CP1-MPA to measure soil temperature.

2.1.3 Blower Unit

A 1-horsepower Gast® regenerative blower unit was used for both the initial and the extended pilot tests. For the extended pilot test, the blower was installed in the boiler room located behind Building 13115. The fixed unit is plugged into a 120-volt outlet in the boiler room. The configuration, instrumentation, and specifications for this blower system are shown in Figure 2.7. The blower is currently injecting air at a total flow rate of approximately 20 standard cubic feet per minute (scfm) into CP1-VW1 and approximately 5 scfm into CP1-VW2 for the extended pilot test. After blower installation and start-up, Parsons ES engineers provided an operation and maintenance manual, equipment specifications, and monitoring forms, to base personnel. A copy of the O&M manual is provided in Appendix A.



ASPHALT

CONCRETE

NEW ABOVE
GROUND
STORAGE TANK

BLOWER

SIDEWALK

2" PVC PIPING

VW1

STAIRS

UST

VALVE BOX

VW2

2" PVC PIPING
(UNDERGROUND)

MPA

FLOW
RATE
PORTS

LARGE
EUCALYPTUS
TREE

DIRT

BLDG
13115

LEGEND

- ▲ VENT WELL
- ⊕ VAPOR MONITORING POINT
- 1000 GALLON HEATING OIL UST
- 2-INCH DIA. PVC PIPING
- - - 2-INCH DIA. PVC PIPING (UNDERGROUND)
- ⊗ PVC BALL OR GATE VALVE

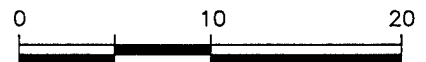

PARSONS ENGINEERING SCIENCE, INC.

OFFICES IN PRINCIPAL CITIES



9404 GENESEE AVENUE • SUITE 140
LA JOLLA, CA 92037 • (619) 453-9650

DESIGNED BY:

LD

DRAWN BY:

MSB

DATE:

12/7/94

FIGURE 2.5
RECORD DRAWING BLOWER AND
PIPING SYSTEM DIAGRAM
SITE 13115 - HEATING OIL UST
MCB CAMP PENDLETON, CALIFORNIA

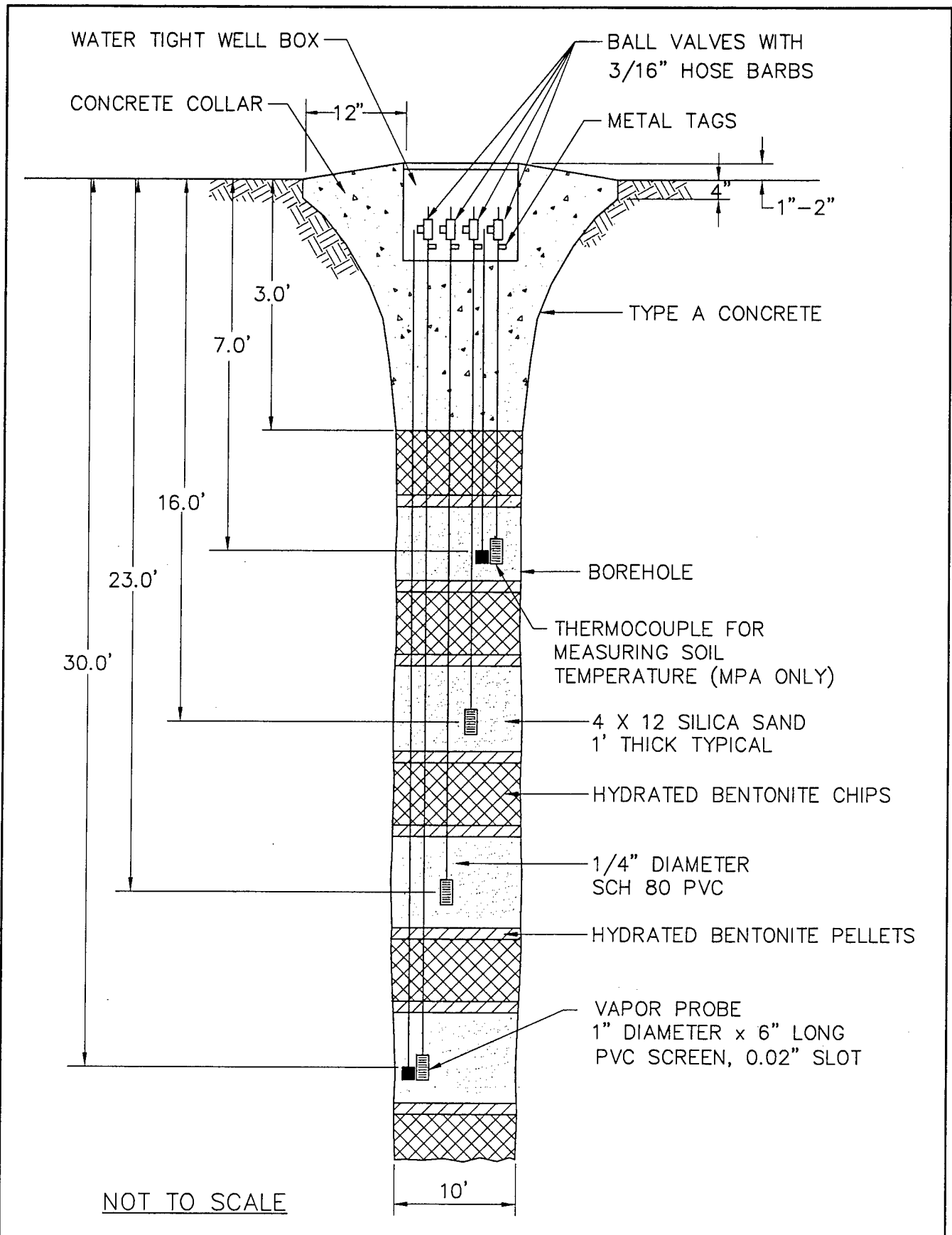

PARSONS ENGINEERING SCIENCE, INC.

OFFICES IN PRINCIPAL CITIES



9404 GENESEE AVENUE • SUITE 140
LA JOLLA, CA 92037 • (619) 453-9650

DESIGNED BY:

LD

DRAWN BY:

MSB

DATE:

12/14/94

FIGURE 2.6







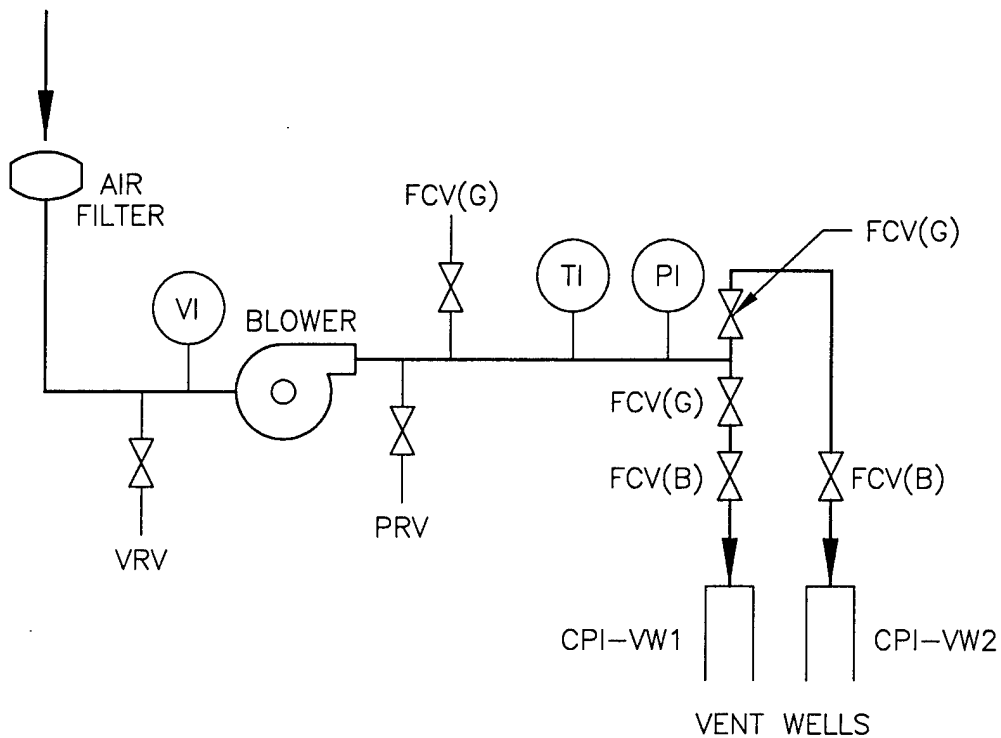

RECORD DRAWING MONITORING POINT
CONSTRUCTION DETAILS

SITE 13115 - HEATING OIL UST
MCB CAMP PENDLETON, CALIFORNIA

FROM
ATMOSPHERE



LEGEND

-  INLET AIR FILTER GAST[®] AJ 126D
-  VRV VACUUM RELIEF VALVE GAST[®] AG 258 SET TO RELEASE AT 30 IN H₂O VACUUM
-  VI VACUUM GAUGE (-60 - 0 IN H₂O) GAST[®] AJ 497
-  BLOWER GAST[®] 1HP R4110N -50
-  PRV PRESSURE RELIEF VALVE GAST[®] AG 258 SET TO RELEASE AT 40 IN H₂O PRESSURE
-  FCV(G) FLOW CONTROL VALVE (GATE)
-  TI TEMPERATURE GAUGE (0 - 250°F) ASHCROFT[®] 30E 160R 025
-  PI PRESSURE GAUGE (0 - 60 IN H₂O) GAST[®] AJ 496
-  FCV(B) FLOW CONTROL VALVE (BALL)

PARSONS ENGINEERING SCIENCE, INC.

OFFICES IN PRINCIPAL CITIES



9404 GENESEE AVENUE • SUITE 140
LA JOLLA, CA 92037 • (619) 453-9650

DESIGNED BY:

LD

DRAWN BY:

MSB

DATE:

12/14/94

FIGURE 2.7
BLOWER SYSTEM
INSTRUMENTATION DIAGRAM FOR AIR INJECTION
SITE 13115 - HEATING OIL UST
MCB CAMP PENDLETON, CALIFORNIA

2.2 Soil and Soil Gas Sampling Results

2.2.1 Soil Sampling Results

Sediments encountered beneath the site range from clays to fine gravels (Figure 2.2). Sediments encountered between the ground surface and 15 feet bgs consist of finer sediments ranging from clays to silty sands. A clay layer, up to 7 feet thick is found near the UST. This clay layer pinches out to the south near boring B13115-6. A silt layer, approximately 5 feet thick, is found between 10 to 15 feet bgs. The most abundant sediment type encountered beneath the site is well to poorly graded sands. The sands were encountered approximately 15 feet below the ground surface (bgs) down to a depth of 40 feet bgs. Up to 10-foot-thick lenses of silty sand and silt occur within the sands. Between 30 and 35 feet bgs the sand is underlain by a layer of sand and gravel approximately 5 feet thick. No ground water was encountered at the site.

Soil samples for laboratory analysis were collected at CP1-VW1-20, CP1-VW2-10 and CP1-MPA-30 using 18-inch split-spoon samplers with 2-inch diameter brass liners. Soil samples were shipped via Federal Express® to Pace laboratory in Huntington Beach, California, for chemical and physical analysis. Soil samples were analyzed for Total Recoverable Petroleum Hydrocarbons (TRPH) by EPA 418.1; Benzene, Toluene, Ethylbenzene and Xylenes (BTEX) by EPA 8020; iron; alkalinity; phosphates; pH; Total Kjeldahl Nitrogen (TKN); moisture content; and grain-size distribution. The results of these analyses are provided on Table 2.1. Chain-of-custody forms are provided in Appendix B.

Field evidence of hydrocarbon contamination was encountered from about 5 feet bgs to 35 feet bgs in CP1-VW1 and from 5 feet bgs to 16 feet bgs, the total depth of CP1-VW2. Both borings are located approximately 5 feet from the UST. Soils at these depths had moderate to strong hydrocarbon odors and had GasTech® hydrocarbon analyzer head space readings of up to 200 ppmv. However, no signs of soil staining or discoloration were observed. Soil from CP1-MPA had weak to moderate hydrocarbon odors from about 6 to 30 feet bgs. There was no field evidence of contamination in CP1-MPB or CP1-MPC. Analytical results ranged from 27.1 mg/kg for TRPH and non-detect for BTEX in CP1-VW2-10 to 9260 mg/kg for TRPH and non-detect, 1300 mg/kg, 160 mg/kg and 1400 mg/kg for BTEX, respectively, in CP1-VW1-20.

2.2.2 Soil Gas Sampling Results

Soil gas samples were collected from CP1-VW1, CP1-MPA-30, CP1-MPC-30 using 3-liter Tedlar® bags and a vacuum chamber. After the samples were collected in the Tedlar® bags, they were transferred to 1-liter SUMMA® canisters and shipped to the laboratory.

Soil gas samples were shipped via Federal Express® to Air Toxics, Inc., in Folsom, California for analysis by EPA TO-3 for Total Volatile Hydrocarbons (TVH) and BTEX. The TVH analyses were referenced to jet fuel (Molecular Weight = 156) as there is no suitable analysis for the volatile fraction of heating oil. The results of these analyses are provided on Table 2.1. Chain-of-custody forms are

Table 2.1

**Soil and Soil Gas Laboratory Analytical Results
Site 13115 Heating Oil UST
Marine Corps Base Camp Pendleton, California**

Analyte (Units) ^a	Sample Location - Depth (Feet Below Ground Surface)			
	CP1-VW1	CP1-MPA-30	CP1-MPC-30	
Soil Gas Hydrocarbons				
TVH ^b (ppmv)	360	860	170	
Benzene (ppmv)	0.28	0.74	ND(0.003)	
Toluene (ppmv)	0.99	2.5	0.066	
Ethylbenzene (ppmv)	1.7	1.9	0.047	
Xylenes (ppmv)	3.6	6.5	0.14	
Soil Hydrocarbons				
TRPH ^c (mg/kg)	9260	27.1	893	--
Benzene (mg/kg)	ND (0.058)	ND (0.059)	ND (0.050)	--
Toluene (mg/kg)	1.300	ND (0.059)	ND (0.050)	--
Ethylbenzene (mg/kg)	0.160	ND (0.059)	ND (0.050)	--
Xylenes (mg/kg)	1.400	ND (0.120)	ND (0.100)	--
Soil Inorganics				
Iron (mg/kg)	906	7280	1880	--
Alkalinity (mg/kg as Ca CO ₃ ^d)	150	80	120	--
pH (Units)	8.75	7.59	6.77	--
TKN ^e (mg/kg)	ND(40)	ND(40)	180	ND (40)
Phosphates (mg/kg)	33	71	33	--
Soil Physical Parameters				
Moisture (% by wt)	14.7	17.0	0	--
Gravel (%)	0.1	0.0	6.8	--
Sand (%)	85.7	41.5	77.2	--
Silt (%)	10.9	37.1	11.2	--
Clay (%)	3.4	21.4	4.8	--

^a ppmv = parts per million by volume; mg/kg = milligrams per kilogram.

^b TVH = Total Volatile Hydrocarbons by TO-3.

^c TRPH = Total Recoverable Petroleum Hydrocarbons by EPA 418.1.

^d Ca CO₃ = Calcium Carbonate.

^e TKN = Total Kjeldahl Nitrogen.

ND = Not Detected. Detection limits are in parentheses.

-- = Not Analyzed.

provided in Appendix B. TVH concentrations ranged from 170 ppmv in CP1-MPC-30 to 860 ppmv at CP1-MPA-30. Benzene, Toluene, Ethylbenzene, and Total Xylenes concentrations ranged from non-detect, 0.066 ppmv, 0.047 ppmv, and 0.14 ppmv, respectively, in CP1-MPC-30 to 0.74 ppmv, 2.5 ppmv, 1.9 ppmv and 6.5 ppmv, respectively, in CP1-MPA-30.

2.3 Pilot Test Results

2.3.1 Exceptions to Test Protocol Procedures

Procedures described in the protocol document and the site-specific work plan (Part I) were used to complete the pilot test at this site. An exception to the protocol document included the addition of a second VW as previously described. Exceptions to the Part I work plan included adjusting the depths of the MP screened interval in accordance with lithologies and contamination distribution encountered during drilling.

2.3.2 Initial Soil Gas Chemistry

Prior to initiating air injection for the respiration test, the VWs and MPs were purged, and initial oxygen, carbon dioxide, and TVH concentrations were measured using portable gas analyzers, as described in the protocol document.

Table 2.2 summarizes the initial soil gas chemistry at the site. The results strongly indicate that biological fuel degradation has depleted the oxygen supply in the vadose zone near the UST. The zone of depleted oxygen extends from the Heating Oil UST to the soil south of CP1-MPA. Thirty feet from the UST, at CP1-MPB-30, oxygen concentration is still relatively low at 2.2 percent. Oxygen concentrations in the 7-, 16-, and 23-foot depths at CP1-MPB and throughout CP1-MPC were between 10 and 16.5 percent. Carbon dioxide was present at elevated concentrations ranging from 2.5 to 13 percent throughout the site. Carbon dioxide is a by-product of fuel biodegradation.

Despite location about 5 feet from the UST and the presence of hydrocarbon odor during drilling, initial oxygen concentration in CP1-VW2 was relatively high at 17.5 percent. This relatively high oxygen concentration (compared to CP1-VW1) could be due to the top of the well screen being less than 4 feet bgs and in contact with near-surface soil gas with high oxygen concentration. An undetected leak at the well head may also be contributing to the high oxygen concentration.

A background MP (CP1-MPBG) was installed approximately 400 feet northeast of the site. Oxygen concentrations in the background MP ranged from 15.5 to 19.1 percent. Carbon dioxide concentrations ranged from 1.6 to 5.0 percent. The 13- and 20-foot zones of CP1-MPBG had oxygen concentrations below 18 percent; therefore, an *in situ* respiration test was conducted in these two background MPs according to protocol document guidelines. The test was conducted to determine if oxygen uptake is due to factors other than fuel biodegradation.

Table 2.2
Initial Soil Gas Chemistry
Site 13115 Heating Oil UST
Marine Corps Base Camp Pendleton, California

Sample Location	Depth (ft bgs)	O ₂ (percent)	CO ₂ (percent)	TVH-Field (ppmv) ^a	TVH-Lab (ppmv) ^b	Temperature (°F)
CP1-VW1	5.9-35.9	2.6	12.0	1,900	360	--
CP1-VW2	3.75-14	17.5	2.5	44	--	--
CP1-MPA-7 ^c	7	--	--	--	--	72.6
CP1-MPA-16	16	0.0	12.0	1,200	--	--
CP1-MPA-23	23	0.0	13.0	2,600	--	--
CP1-MPA-30	30	0.0	13.0	8,000	860	68.6
CP1-MPB-7	7	12.8	7.0	130	--	--
CP1-MPB-16	16	10.0	7.5	56	--	--
CP1-MPB-23	23	11.2	6.5	120	--	--
CP1-MPB-30	30	2.2	10.5	160	--	--
CP1-MPC-7	7	16.5	2.8	100	--	--
CP1-MPC-16	16	10.0	7.2	100	--	--
CP1-MPC-23 ^d	23	--	--	--	--	--
CP1-MPC-30	30	10.0	6.3	180	170	--
CP1-MPBG-7	7	19.1	1.6	140	--	--
CP1-MPBG-13	13	16.8	4.2	80	--	--
CP1-MPBG-20	20	15.5	5.0	80	--	--
CP1-MPBG-27 ^d	27	--	--	--	--	--

- ^a Total volatile hydrocarbon field screening results.
^b Laboratory results referenced to Jet Fuel (Molecular Weight = 156)
^c No sample due to water in probe.
^d No sample due to tight formation.
-- = Not Analyzed

2.3.3 In Situ Respiration Rates

An *in situ* respiration test was conducted at the site according to protocol document procedures. Air was injected into CP1-MPA-16, CP1-MPA-23, CP1-MPA-30, and CP1-VW1 for 20 hours using 1-scfm air pumps. Due to the temporary presence of water from bentonite hydration during probe installation, a respiration test was not conducted in CP1-MPA-7. A dilution chamber was used to inject helium into the MPs at a concentration between 3 and 4 percent.

During the air injection period, oxygen concentrations in CP1-VW1, CP1-VW2, CP1-MPA-16, CP1-MPA-23, and CP1-MPA-30 were increased to at least 19.0 percent. After air injection ceased, changes in soil gas composition were monitored over time. Oxygen, carbon dioxide, TVH, and helium were measured over a period of approximately 187 hours following the air injection period. The observed rates of

oxygen utilization were then used to estimate the aerobic fuel degradation rates at the site using procedures outlined in Section 5.7 of the protocol document. Figures 2.8 through 2.12 present the results of *in situ* respiration testing at the site, and Table 2.3 provides a summary of the observed oxygen utilization rates. The oxygen utilization rates observed in contaminated soils were very consistent and ranged from 0.019 percent per hour (%/hr) to 0.023 %/hr. Helium levels remained relatively constant when compared to oxygen utilization, indicating that MP leaks or diffusion were not contributing to oxygen loss.

A respiration test was also conducted in background points CP1-MPBG-13 and CP1-MPBG-20. Oxygen concentrations were increased to 20.5 percent by air injection as described above. The points were monitored for approximately 7 days. During this time, oxygen concentrations in CP1-MPBG-13 and CP1-MPBG-20 decreased 1 and 1.3 percent, respectively. Due to this very low rate of background oxygen utilization, respiration rates observed in CP1-VW1 and CP1-MPA are attributed to biological breakdown of petroleum hydrocarbons and not inorganic or natural carbon sources.

An estimated 40 to 170 milligrams (mg) of fuel per kilogram (kg) of soil can be biodegraded each year. The fuel consumption rates were calculated using the observed oxygen utilization rate in CP1-VW1, CP1-VW2, CP1-MPA-16, CP1-MPA-23, and CP1-MPA-30, estimated air-filled porosities of 0.213 and 0.05 liters of air/kg of soil for silty clay and sandy soils, respectively, and a conservative ratio of 3.5 mg of oxygen consumed for every 1 mg of fuel biodegraded.

2.3.4 Air Permeability

An air permeability test was conducted at the site according to protocol document procedures. During the test, the majority of the air flow was through the pressure relief valve. With the pressure relief valve set at 30 inches of water, the flow rate was measured at approximately 4 scfm. Air was injected into CP1-VW1 for approximately 20 hours at a rate of approximately 4 scfm. The pressure responses at CP1-VW2 and each MP are listed on Table 2.4. The pressure measured at most MPs continued to rise slightly for the first 3 hours. A minimum radius of pressure influence of 74.1 feet was observed at all depths in CP1-MBC except for 7 feet bgs. There was no observed pressure increase at 7 feet bgs in CP1-MPB or CP1-MPC, however, a slight pressure increase was observed in CP1-MPA-7, 14.6 feet from CP1-VW1.

The dynamic method of determining air permeability, as detailed in the protocol document, was used to calculate air permeability. Permeability values ranged from 5 to 12 darcys. However, these calculated permeabilities seem high compared to the physical appearance of soil samples. Lower permeability readings were associated with the tighter soils observed above 15 feet bgs and in a silt lens at CP1-MPA-30.

2.3.5 Oxygen Influence

The depth and radius of oxygen influence in the subsurface, resulting from air injection into the central VW during pilot testing, is the primary design parameter for full-scale bioventing systems. Optimization of full-scale and multiple VW systems requires pilot testing to determine the volume of soil that can be oxygenated at a given flow rate and VW screen configuration.

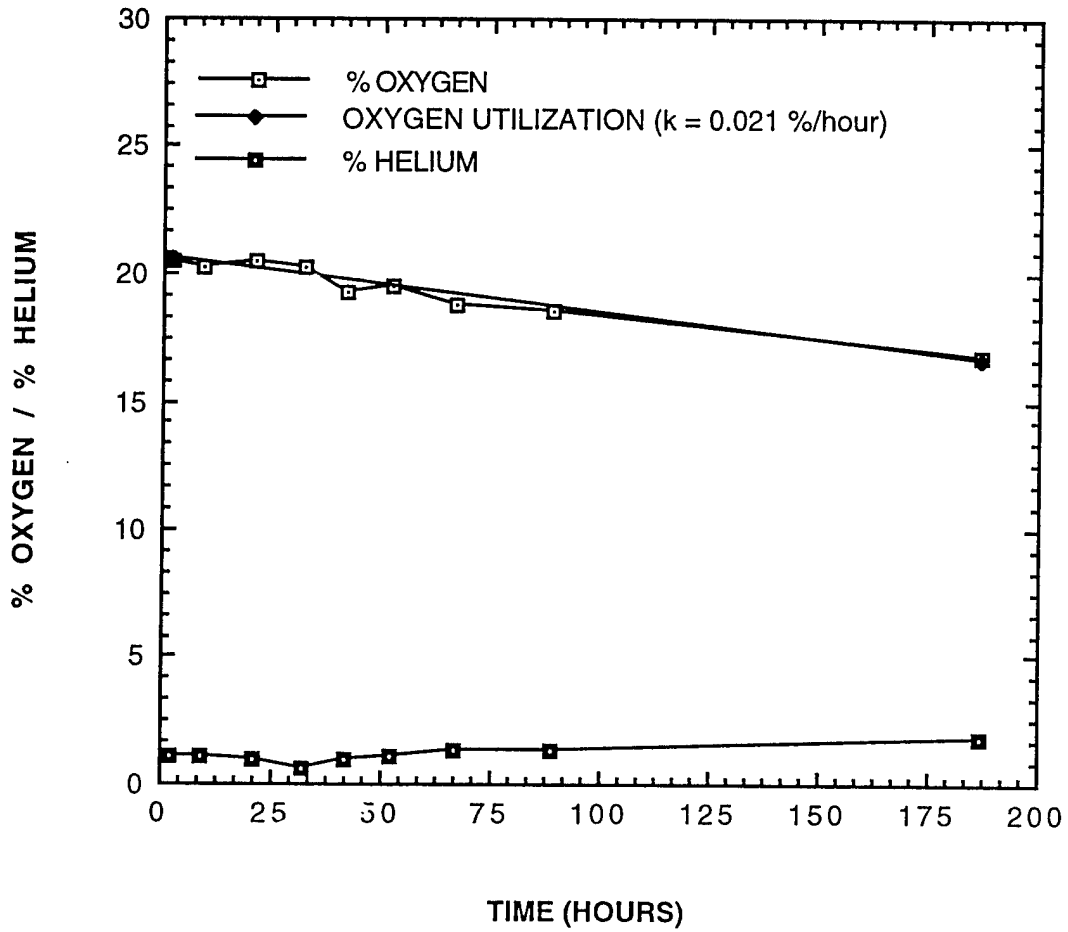

PARSONS ENGINEERING SCIENCE, INC.

OFFICES IN PRINCIPAL CITIES



9404 GENESEE AVENUE • SUITE 140
LA JOLLA, CA 92037 • (619) 453-9650

DESIGNED BY:

LD

DRAWN BY:

MSB

DATE:

12/14/94

FIGURE 2.8
RECORD DRAWING RESPIRATION TEST
CPI-VW1
SITE 13115 - HEATING OIL UST
MCB CAMP PENDLETON, CALIFORNIA

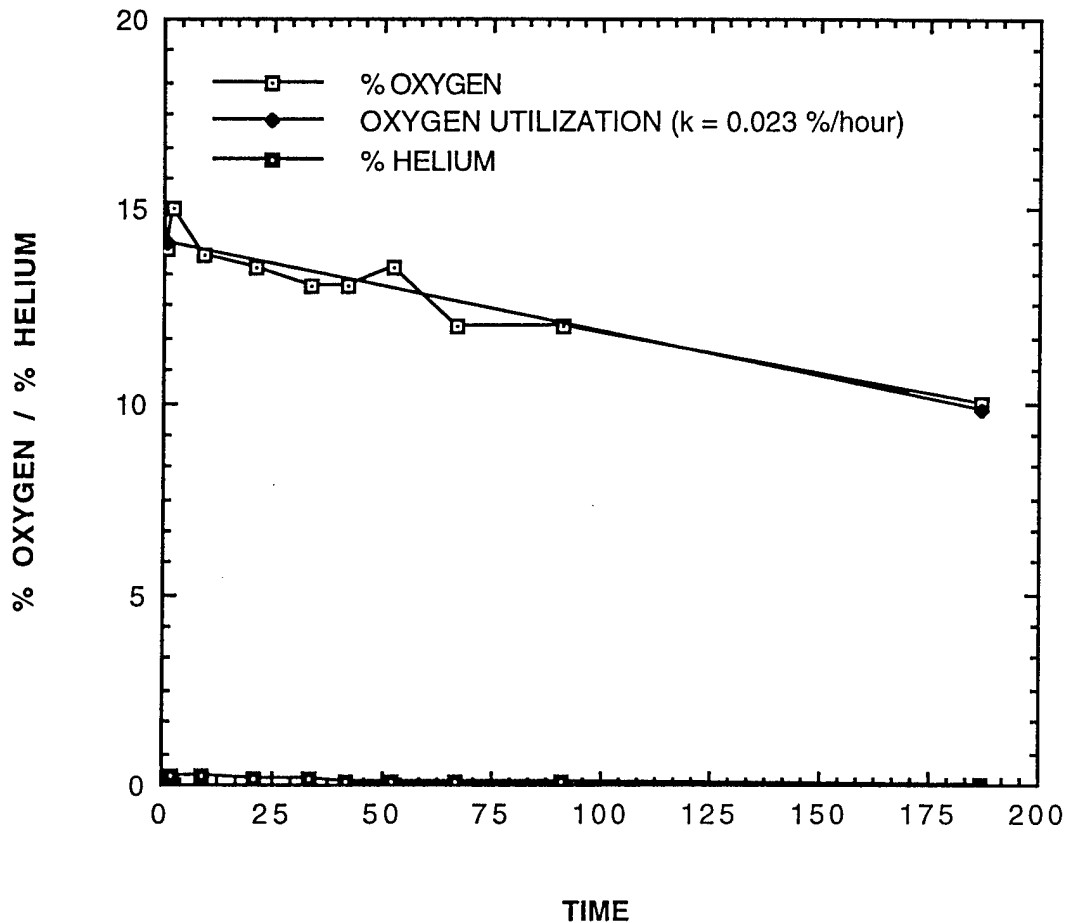

PARSONS ENGINEERING SCIENCE, INC.

OFFICES IN PRINCIPAL CITIES



9404 GENESEE AVENUE • SUITE 140
LA JOLLA, CA 92037 • (619) 453-9650

DESIGNED BY:

LD

DRAWN BY:

MSB

DATE:

12/14/94

FIGURE 2.9
RECORD DRAWING RESPIRATION TEST
CPI-VW2
SITE 13115 - HEATING OIL UST
MCB CAMP PENDLETON, CALIFORNIA

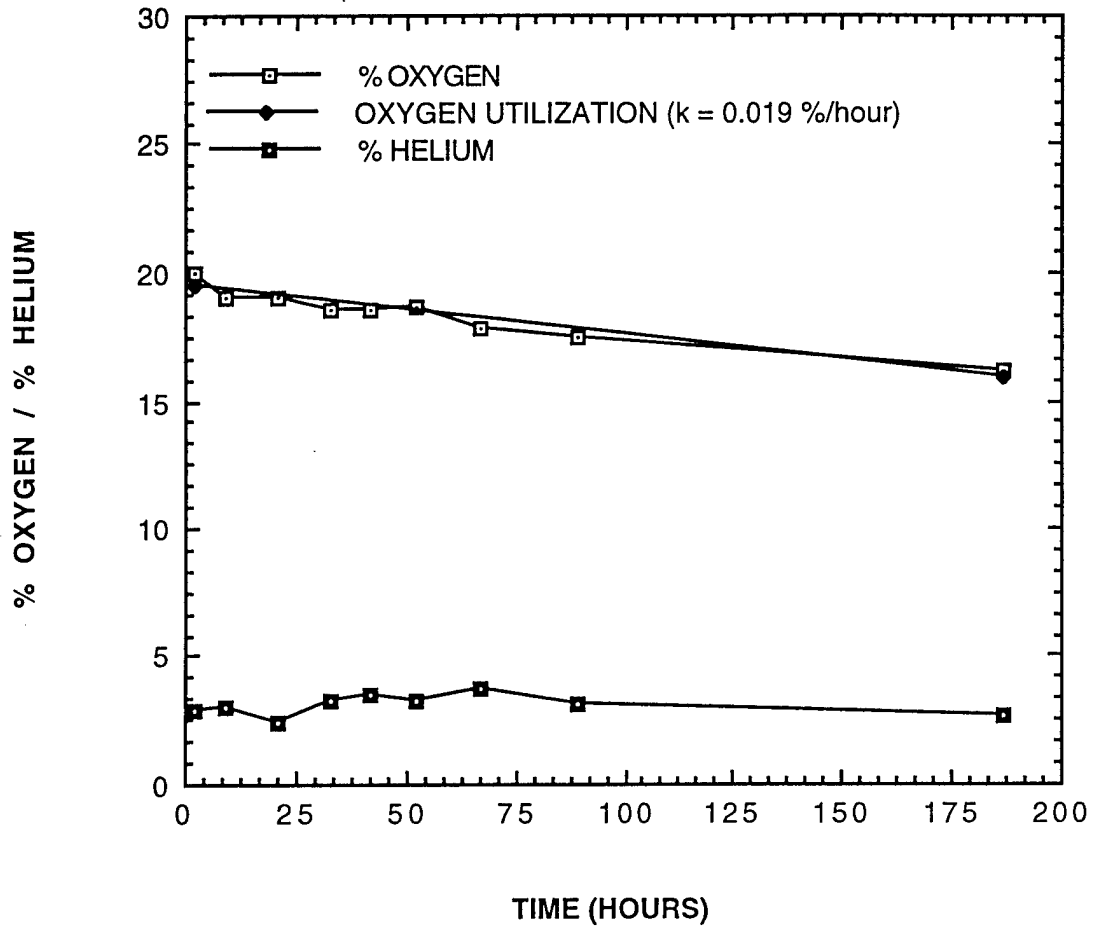

PARSONS ENGINEERING SCIENCE, INC.

OFFICES IN PRINCIPAL CITIES



9404 GENESEE AVENUE • SUITE 140
LA JOLLA, CA 92037 • (619) 453-9650

DESIGNED BY:

LD

DRAWN BY:

MSB

DATE:

12/14/94

FIGURE 2.10
RECORD DRAWING RESPIRATION TEST
CPI-MPA-16
SITE 13115 - HEATING OIL UST
MCB CAMP PENDLETON, CALIFORNIA

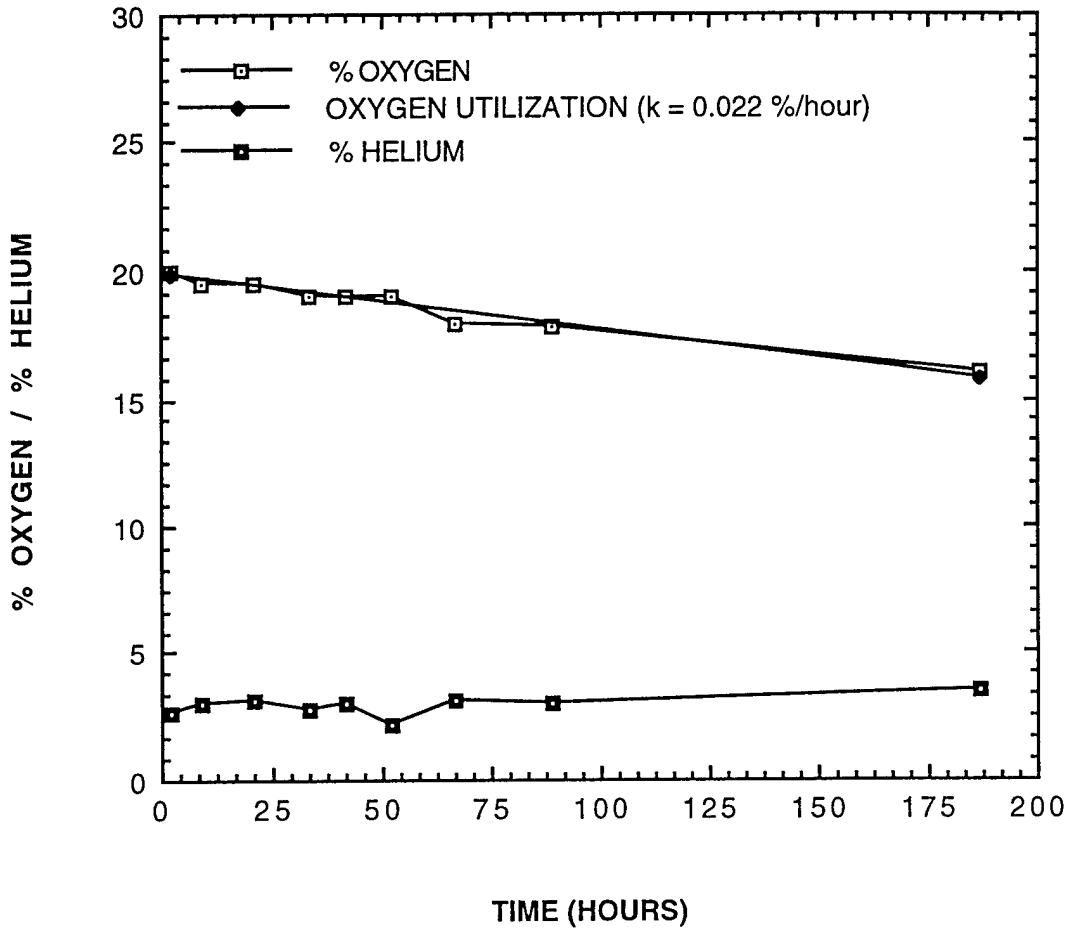

PARSONS ENGINEERING SCIENCE, INC.

OFFICES IN PRINCIPAL CITIES



9404 GENESEE AVENUE • SUITE 140
LA JOLLA, CA 92037 • (619) 453-9650

DESIGNED BY:

LD

DRAWN BY:

MSB

DATE:

12/14/94

FIGURE 2.11
RECORD DRAWING RESPIRATION TEST
CPI-MPA-23
SITE 13115 - HEATING OIL UST
MCB CAMP PENDLETON, CALIFORNIA

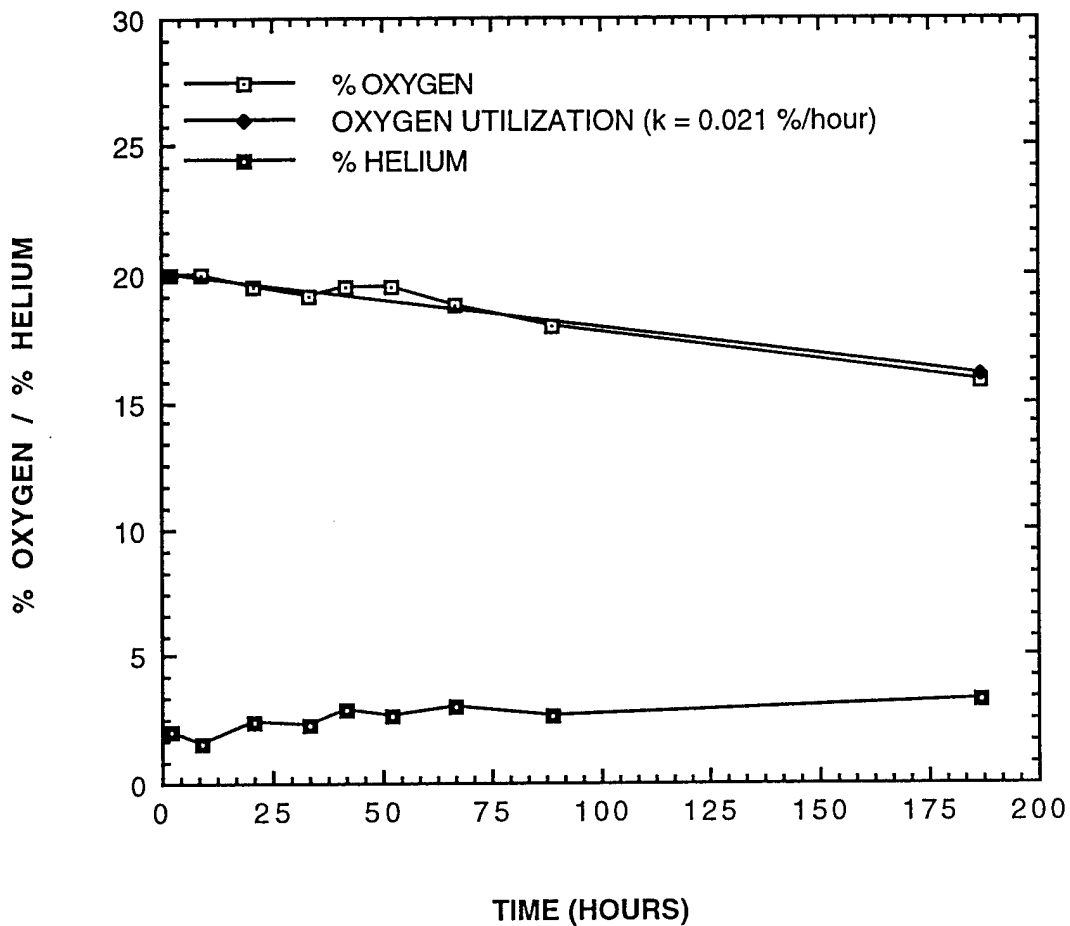

PARSONS ENGINEERING SCIENCE, INC.

OFFICES IN PRINCIPAL CITIES



9404 GENESEE AVENUE • SUITE 140
LA JOLLA, CA 92037 • (619) 453-9650

DESIGNED BY:

LD

DRAWN BY:

MSB

DATE:

12/14/94

FIGURE 2.12
RECORD DRAWING RESPIRATION TEST
CPI-MPA-30
SITE 13115 - HEATING OIL UST
MCB CAMP PENDLETON, CALIFORNIA

Table 2.3
Oxygen Utilization Rates
Site 13115 Heating Oil UST
Marine Corps Base Camp Pendleton, California

Location	O ₂ Loss ^a (percent)	Test Duration (hr)	O ₂ Utilization ^a Rate (percent/hr)	Hydrocarbon Degradation Rate (mg/kg/yr)
CP1-VW-1	4.0	186	0.021	40
CP1-VW-2	4.0	186	0.023	170
CP1-MPA-16	3.8	186	0.019	30
CP1-MPA-23	4.0	186	0.022	40
CP1-MPA-30	3.2	186	0.021	140

^a Value based on linear regression.

Table 2.5 describes the change in soil gas oxygen levels that occurred after 30 days of air injection at the site. This air injection period at 4 scfm produced increases in soil gas oxygen levels at a distance of at least 35.6 feet from the central VW at all depths in CP1-MPB. Oxygen concentration at CP1-MPC, 74.1 feet from CP1-VW1, increased slightly at 7 feet bgs, but decreased slightly at 16 and 30 feet bgs. This decrease is most likely a result of soil gas with lower oxygen concentration being displaced outward as air is being injected into CP1-VW1.

The zone of oxygen influence appears to be beyond the known limit of contamination in the sandier soils below 15 feet bgs. The zone of oxygen influence in the silty clay above 15 feet bgs is less certain. CP1-MPA-7 could not be sampled due to residual probe construction water. CP1-MPB-7 and CP1-MPC-7 had oxygen increases of 1 percent after 30 days of air injection. This slight increase is within the limit of field equipment error. Therefore, to insure adequate oxygenation of sandy and clayey zones, the flow control valves to CP1-VW2 were opened slightly. Currently, air is being injected into CP1-VW1 and CP1-VW2 at approximately 4 scfm and 2 scfm respectively. These flow rates and the tendency of oxygen-rich soil gas to diffuse into areas of oxygen-deficient soil gas, even in clay-rich zones, should provide sufficient oxygen to all heating oil related contaminated soil at the site.

2.3.6 Potential Air Emissions

Site contamination consists of heating oil fuel, a compound of relatively low volatility. Soil samples had maximum field head space readings of 200 ppmv. The maximum TVH concentration determined by laboratory analysis was 860 ppmv. Maximum BTEX concentrations of 0.74, 2.5, 1.9, and 6.5 ppmv, respectively, were detected. The long-term potential for air emissions from full scale bioventing operations at this site is low. Initial emissions should be minimal because accumulated vapors will move slowly outward from the air injection point and will

Table 2.4

**Pressure Response (inches of water) During Air Permeability Test
Site 13115 Heating Oil UST
Marine Corps Base Camp Pendleton, California**

Elapsed Time (Minutes)	Location and Depth (ft. bgs)													
	CP-VW2		CP1-MPA				CP1-MPB				CP1-MPC			
	7	16	23	30	7	16	23	30	7	16	23	30		
0	0.0	0.0	0.0	0.0	0.0	0.0	0.0	0.0	0.0	0.0	0.0	0.0	0.0	
1	0.0	0.0	0.0	0.0	0.0	0.0	0.0	0.0	0.0	0.0	0.0	0.0	0.0	
2	0.0	0.05	0.1	0.1	0.1	0.0	0.0	0.0	0.05	0.0	0.1	0.0	0.1	
3	0.1	0.05	0.2	0.2	0.3	0.0	0.0	0.0	0.0	0.0	0.1	0.0	0.1	
4	0.1	0.05	0.2	0.3	0.3	0.0	0.0	0.0	0.0	0.0	0.1	0.0	0.0	
5	0.1	0.05	0.2	0.3	0.4	0.0	0.0	0.0	0.05	0.0	0.1	0.0	0.0	
6	0.1	0.05	0.2	0.3	0.4	0.0	0.0	0.0	0.0	0.0	0.1	0.0	0.0	
7	0.1	0.05	0.2	0.4	0.5	0.0	0.0	0.0	0.0	0.0	0.0	0.0	0.0	
8	0.1	0.05	0.2	0.4	0.5	0.0	0.0	0.0	0.0	0.0	0.0	0.0	0.0	
9	0.1	0.05	0.3	0.4	0.5	0.0	0.0	0.0	0.0	0.0	0.0	0.0	0.0	
10	0.1	0.05	0.3	0.4	0.6	0.0	0.0	0.0	0.0	0.0	0.0	0.0	0.0	
12	0.1	0.05	0.3	0.4	0.6	0.0	0.0	0.0	0.0	0.0	0.0	0.0	0.0	
14	0.1	0.05	0.3	0.4	0.6	0.0	0.0	0.0	0.0	0.0	0.1	0.0	0.0	
16	0.1	0.05	0.3	0.4	0.6	0.0	0.05	0.1	0.05	0.0	0.1	0.0	0.0	
18	0.1	0.05	0.4	0.5	0.7	0.0	0.1	0.2	0.2	0.0	0.1	0.0	0.05	
20	0.1	0.05	0.4	0.5	0.7	0.0	0.1	0.2	0.2	0.0	0.1	0.0	0.05	
22	0.1	0.05	0.4	0.5	0.8	0.0	0.2	0.2	0.2	0.0	0.2	0.0	0.05	
24	0.1	0.05	0.3	0.5	0.8	0.0	0.2	0.2	0.3	0.0	0.1	0.1	0.1	
26	0.1	0.05	0.4	0.6	0.9	0.0	0.2	0.3	0.3	0.0	0.2	0.2	0.1	
28	0.1	0.05	0.4	0.6	0.9	0.0	0.3	0.3	0.4	0.0	0.2	0.3	0.1	
30	0.1	0.05	0.4	0.6	0.9	0.0	0.3	0.3	0.4	0.0	0.2	0.4	0.1	
33	0.1	0.05	0.4	0.6	0.9	0.0	0.3	0.3	0.5	0.0	0.1	0.5	0.1	
36	0.1	0.05	0.5	0.6	1.0	0.0	0.2	0.2	0.3	0.0	0.15	0.7	0.05	
39	0.1	0.05	0.5	0.7	1.0	0.0	0.2	0.2	0.3	0.0	0.15	0.75	0.1	
42	0.1	0.05	0.5	0.7	1.0	0.0	0.2	0.25	0.3	0.0	0.15	0.75	0.1	
45	0.1	0.05	0.5	0.7	1.0	0.0	0.05	0.2	0.3	0.0	0.15	0.95	0.1	
48	0.1	0.05	0.5	0.7	1.0	0.05	0.2	0.25	0.35	0.0	0.2	1.1	0.15	
51	0.1	0.05	0.5	0.75	1.1	0.0	0.25	0.25	0.35	0.0	0.2	1.1	0.15	
54	0.1	0.05	0.5	0.75	1.1	0.0	0.2	0.25	0.35	0.0	0.15	1.05	0.10	
57	0.1	0.05	0.5	0.75	1.1	0.0	0.2	0.25	0.35	0.0	0.15	0.5	0.15	
60*	0.1	0.05	0.5	0.75	1.1	0.0	0.25	0.25	0.35	0.0	0.20	0.0	0.15	
75	0.1	0.05	0.4	0.7	0.9	0.0	0.3	0.35	0.45	0.0	0.25	0.0	0.15	
90	0.2	0.05	0.4	0.8	1.3	0.05	0.25	0.35	0.45	0.0	0.15	0.0	0.1	
105	0.2	0.05	0.4	0.8	1.4	0.05	0.2	0.25	0.4	0.0	0.15	0.0	0.1	
120	0.2	0.0	0.4	0.8	1.4	0.05	0.25	0.3	0.45	0.0	0.15	0.0	0.05	
150	0.2	0.4	0.5	0.9	1.5	0.05	0.25	0.35	0.50	0.0	0.20	0.4	0.15	
180	0.2	0.9	0.5	0.9	1.5	0.05	0.27	0.35	0.5	0.0	0.15	0.55	0.15	
240	0.2	0.05	0.45	0.9	1.5	0.05	0.25	0.35	0.5	0.0	0.15	<0	0.15	
480	0.05	0.05	0.2	0.45	1.2	0.0	0.0	0.05	0.15	<0	<0	<0	<0	
1200	0.05	0.05	0.2	0.60	1.2	0.0	0.0	0.05	0.15	<0	<0	1.6	<0	

* Collected soil gas samples.

Table 2.5

**Influence of Air Injection Vent Well on Monitoring Point Oxygen Levels
Site 13115 Heating Oil UST
Marine Corps Base Camp Pendleton, California**

Sample Location	Distance from VW1 (ft)	Depth (ft. bgs)	Initial O ₂ ^a (percent)	Final O ₂ ^b (percent)
CP1-VW-2	9.6	3.75-16	17.5	16.0
CP1-MPA-16	14.6	16	0.0	20.1
CP1-MPA-23	14.6	23	0.0	20.0
CP1-MPA-30	14.6	30	0.0	20.5
CP1-MPB-7	35.6	7	12.8	13.8
CP1-MPB-16	35.6	16	10.0	17.5
CP1-MPB-23	35.6	23	11.2	12.0
CP1-MPB-30	35.6	30	2.2	18.2
CP1-MPC-7	74.1	7	16.5	17.6
CP1-MPC-16	74.1	16	10.0	8.8
CP1-MPC-30	74.1	30	10.0	6.2

^a Initial site readings.

^b Readings after 31 days of air injection.

be biodegraded as they move horizontally through the soil. During the air permeability test, air was injected at 4 scfm. Health and safety hydrocarbon-analyzer air monitoring of the breathing zone at the site indicated that total hydrocarbon concentrations did not increase above 1 ppmv during the initial days of the test. The initial day of bioventing generally produces the highest potential for emissions as the first pore volume of soil gas is replaced.

2.4 Recommendations

Field observations and analytical results tend to indicate the extent of contamination has been greatly over estimated. Figures from previous reports show heating oil contamination extending to the southern end of the building, approximately 80 feet from the UST. However, previous site investigation borings appear to be closer to the UST than indicated on investigation report figures. Location of VWs and MPs were based on these figures. As a result, it appears that CP1-MPB and CP1-MPC are outside the zone of contamination. At a distance from the UST of approximately 10 feet, CP1-MPA maybe on the edge of the contaminated soil.

Initial bioventing tests at this site indicate that oxygen had been depleted in the contaminated soils, and that air injection is an effective method of stimulating aerobic fuel biodegradation. However, the observed biodegradation rates were lower than expected. The lower than expected biodegradation may be due, in part, to the majority of MPs being located out of the zone of significant soil

contamination. AFCEE has recommended that air injection continue at this site to determine the long-term radius of oxygen influence and the effects of time, available nutrients, and changing temperatures on fuel biodegradation rates.

AFCEE has also recommended the installation of another MP, closer to the UST, in a zone of greater contamination at 15 to 20 feet bgs. Additional soil samples will be collected and analyzed for TRPH, BTEX, moisture, nutrients and salinity. A respiration test will be conducted in this MP. Depending on the results of the sample analysis and the respiration test, the limited addition of moisture and/or nutrients (to the new MP only) will be considered as a means to increase the bioremediation rate.

A 1-horsepower regenerative blower has been installed at the site for continuous air injection. In February 1995, Parsons ES will return to the site to conduct a repeat respiration test. In October 1995, a final respiration test will be conducted, and soil and soil gas samples will be collected from the site to determine the degree of remediation achieved during the first year of *in situ* treatment.

3.0 REFERENCES

- Engineering-Science, Inc. 1992. *Field Sampling Plan for AFCEE Bioventing*. Denver, Colorado.
- Hinchee, R.E., Ong, S.K., Miller, R.N., Downey, D.C., Frandt, R., 1992. *Test Plan and Technical Protocol for a Field Treatability Test for Bioventing*, January.
- Jacobs Engineering, IT Corp. CH₂M Hill, April 1993. Marine Corps Base Camp Pendleton, California. Underground Storage Tank Draft Site Assessment Report.

APPENDIX A
O&M MANUAL

**REGENERATIVE BLOWER
OPERATIONS AND MAINTENANCE MANUAL
FOR EXTENDED TESTING SYSTEM AT
MARINE CORPS BASE CAMP PENDLETON
BUILDING 13115**

Prepared for:

**AIR FORCE CENTER FOR ENVIRONMENTAL EXCELLENCE
BROOKS AFB, TEXAS
AND
ACS ENVIRONMENTAL SECURITY
MCB CAMP PENDLETON, CALIFORNIA**

USAF CONTRACT F33615-90-D-4014, DELIVERY ORDER 14

OCTOBER 1994

Prepared by:

**PARSONS ENGINEERING SCIENCE, INC.
9404 Genesee Avenue, Suite 140
San Diego, California 92037**

SECTION 1

INTRODUCTION

This document has been prepared by Parsons Engineering Science, Inc., to support the bioventing initiative contract awarded by the Air Force Center for Environmental Excellence (AFCEE). The contract involves the conducting of bioventing pilot tests at approximately 135 sites on 38 Air Force Bases across the United States. As part of AFCEES program of technology transfer, several pilot tests are being conducted at military installations other than air force bases.

At most sites, bioventing systems will be installed upon completion of the bioventing pilot tests for the purpose of extended pilot testing. These systems will operate for a one year period to provide further information as to the feasibility of the technology at each site, and to provide interim remedial action.

The Operations and Maintenance Manual has been created for sites at which blowers have been installed for extended pilot testing. Basic maintenance of these systems is the responsibility of the base. The manual is to be used by base personnel to guide and assist them in operating and maintaining the blower system. Section 2 provides a synopsis of the blower system configuration. Section 3 of this document describes the blower. Section 4 details the maintenance requirements and provides maintenance schedules. Section 5 describes the system monitoring that is required to forecast system maintenance needs and provide data for the extended pilot test.

SECTION 2

BLOWER SYSTEM CONFIGURATION SUMMARY

System Type	injection
Blower	regenerative
Blower Model	R4110N-50
Motor (Horsepower)	1.0
Knock-Out Chamber	none
Sampling Port	none
Inlet Temperature Gauge (range)	not applicable
Inlet Vacuum Gauge (range)	-60" - 0" H ₂ O
Inlet Filter (part no.)	AJ134E
Outlet Temperature Gauge (range)	0°-250° F
Outlet Pressure Gauge (range)	0" - 60" H ₂ O
Pressure/Vacuum Relief Valve Set @ (give unit of measure)	30" H ₂ O

SECTION 3

BIOVENTING SYSTEM OPERATION

3.1 PRINCIPLE OF OPERATION

Bioventing is the forced injection of fresh air, or withdrawal of soil gas, to enhance the supply of oxygen for *in situ* bioremediation. Either a pressure (air injection) or vacuum (vapor extraction) blower unit is used to inject or withdraw air into or from the soil, thereby supplying fresh air with 20.8 percent oxygen to the contaminated soils. Once oxygen is provided to the subsurface, existing bacteria will proceed with the breakdown of fuel residuals.

An injection blower system has been installed at MCB Camp Pendleton, Building 13115.

3.2 SYSTEM DESCRIPTION

3.2.1 Blower System

A Gast series R4 blower powered by a one horsepower direct-drive motor is the workhorse of this bioventing system. This blower is rated at a flow rate of 92 standard cubic feet per minute (scfm) at open flow; however, the actual performance of the blower will vary with changing site conditions. As installed at Building 13115, the blower was producing an estimated flow rate of 65 scfm at a pressure of 28 inches of water. It has been reduced to 30 scfm and should remain at this flow rate. The system includes an air filter to remove any particulates which are entrained in the air stream, and several valves and monitoring gauges which are described in the next section. A schematic of the blower system installed at Building 13115 is shown on the figure in Attachment A. Corresponding blower performance curves, and relevant service information are also provided.

3.2.2 Monitoring Gauges

The bioventing system is equipped with vacuum, pressure, and temperature gauges. Gauges have been installed on the air injection system at the following locations: a vacuum gauge in the inlet piping, a pressure and a temperature gauge in the outlet piping. The temperature gauge is used to monitor the outlet temperature to determine the change in temperature across the blower. Ambient air temperature can be estimated and used as the inlet temperature since an inlet temperature gauge is not present. See the figure in the attachment for the locations of the gauges installed on the blower system.

SECTION 4

SYSTEM MAINTENANCE

Although the motor and blower are relatively maintenance free, periodic system maintenance is required for proper operation and long life. Recommended maintenance procedures and schedules are described in detail in the instruction manuals included in Attachments A and B and briefly summarized in this section.

Filter inspection must be performed with the system turned off. To re-start the motor, open the manual air dilution valve to protect the motor from excessive strain, start motor, and slowly close dilution valve.

4.1 BLOWER/MOTOR

The blower and motor are relatively maintenance free and should not require any periodic maintenance during the 1-year extended testing period. Both blower and motor have sealed bearings and do not require lubrication.

4.2 AIR FILTER

To avoid damage caused by passing solids through the blower, an air filter has been installed in-line before the blower. The filter element is paper and is accompanied by a polyurethane foam prefilter. The filter should be checked weekly for the first 2 months of operation. Again, a facility employee should determine the best schedule for filter replacement. The polyurethane prefilters can be washed with lukewarm water and a mild detergent. Paper filter elements should never be washed, but should be disposed of and replaced as necessary. When the inlet vacuum is above 25 inches of water, a dirty filter element should be suspected, and cleaning or replacement should be performed.

To remove the filter, loosen the wing nut, lift the metal top off the air filter, and lift the air filter from the metal housing. Remove the polyurethane prefilter (if applicable) and wash before replacing. When replacing the filter, be careful that the rubber seals remain in place.

The filter element is manufactured by Gast Manufacturing Corp. in Benton Harbor, Michigan. Their telephone number is (616) 926-6171. Additional filters can also be obtained through Parsons ES in La Jolla, California. The Parsons ES contact is Mr. Larry Dudus. He can be reached at (619) 453-9650. The filter model number is AJ126D, and the number for the replacement element is AJ134E. It is recommended that at least one spare air filter be kept at the site, four spare filters were supplied with the blower system.

4.3 MAINTENANCE SCHEDULE

The following maintenance schedule is recommended for this system. The filter should be checked once per month and washed or replaced as necessary (see Section 5.2). During the initial months of operation more frequent monitoring is recommended to ensure that any start-up problems are quickly corrected. A daily drive-by inspection is recommended during the initial 2 weeks of operation to ensure that the blower system is still operating with no unusual sounds. Data collection sheets that can be used to record maintenance activities are included in Attachment B.

4.4 TROUBLESHOOTING

<u>Symptoms</u>	<u>Possible Diagnosis</u>	<u>Possible Remedy</u>
Excess Vibration	Impeller damaged by foreign material Impeller contaminated by foreign material	Replace impeller Clean impeller, install adequate filtration
Abnormal Sound	Motor bearing failed Impeller rubbing against cover or housing	Replace bearings Repair blower, check clearances
Increase in Sound	Foreign material can coat or destroy muffler foam	Replace foam muffler elements, trap or filter foreign material
Blown Fuse	Electrical wiring problem	Have qualified person check fuse capacity and wiring
Unit Very Hot	Running at too high a pressure or vacuum	Install or adjust relief valves

4.5 MAJOR REPAIRS

Blowers systems are very reliable when properly maintained. Occasionally, a motor or blower will develop a serious problem. If a blower system fails to start, and a qualified electrician verifies that power is available at the blower, the Parsons ES Site Manager, Larry Dudus, should be called at (619) 453-9650. Parsons ES is responsible for major repairs during the first year of operation.

SECTION 5

SYSTEM MONITORING

5.1 BLOWER PERFORMANCE MONITORING

To monitor the blower performance, vacuum, pressure, and temperature will be measured. These data should be recorded weekly on a data collection sheet (provided in Attachment B). All measurements should be taken at the same time while the system is running. Because the system is loud, hearing protection should be worn at all times.

5.1.1 Vacuum/Pressure

With hearing protection in place, open the boiler room door where the blower is housed and record all vacuum and pressure readings directly from the gauges (in inches of water or psi). Record the measurements on a data collection sheet (Attachment B).

5.1.2 Flow Rate

The flow rate through the vent well and soils can be calculated when the inlet vacuum and outlet pressure of the blower are known and if the flow through the air bleed valve is known. The pressure change across the blower (vacuum + pressure) can be compared to the performance curves for the blower in Attachment A to determine the approximate flow rate.

5.1.3 Temperature

With hearing protection in place, open the boiler room door where the blower is housed and record the temperature readings directly from the gauges in degrees Fahrenheit (°F). Record the measurements on a data collection sheet (provided in Attachment B). If required the temperature change can be converted to degrees Celsius (°C) using the formula $^{\circ}\text{C} = (^{\circ}\text{F} - 32) \times 5/9$.

5.3 MONITORING SCHEDULE

The following monitoring schedule is recommended for this system. During the initial months of operation, more frequent monitoring is recommended to ensure that any start up problems are quickly corrected. Data collection sheets have been provided to assist your data collection and are included in Attachment B.

Monitoring Item

Monitoring Frequency

Vacuum/Pressure

Once per week.

Temperature

Once per week.







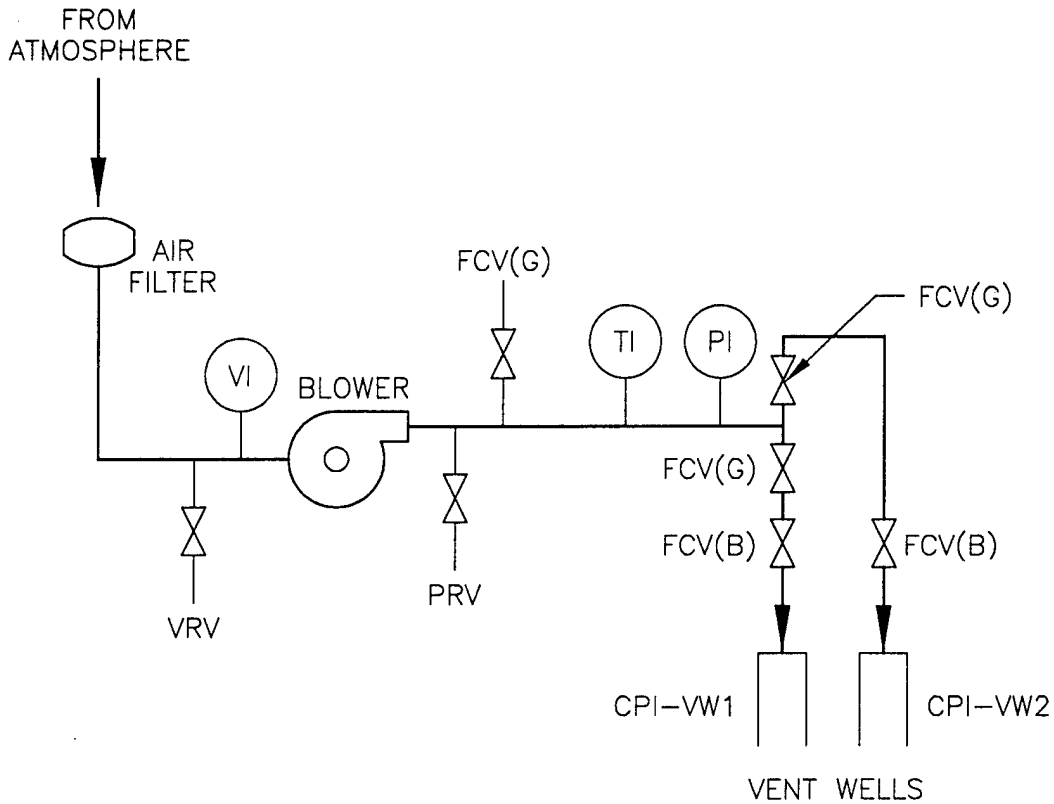

Air Filter

Clean as needed.

ATTACHMENT A



LEGEND

-  INLET AIR FILTER GAST® AJ 126D
-  VRV VACUUM RELIEF VALVE GAST® AG 258 SET TO RELEASE AT 30 IN H2O VACUUM
-  VI VACUUM GAUGE (-60 - 0 IN H2O) GAST® AJ 497
-  BLOWER GAST® 1HP R4110N -50
-  PRV PRESSURE RELIEF VALVE GAST® AG 258 SET TO RELEASE AT 40 IN H2O PRESSURE
-  FCV(G) FLOW CONTROL VALVE (GATE)
-  TI TEMPERATURE GAUGE (0 - 250°F) ASHCROFT® 30E 160R 025
-  PI PRESSURE GAUGE (0 - 60 IN H2O) GAST® AJ 496
-  FCV(B) FLOW CONTROL VALVE (BALL)

PARSONS ENGINEERING SCIENCE, INC.

OFFICES IN PRINCIPAL CITIES



9404 GENESEE AVENUE • SUITE 140
LA JOLLA, CA 92037 • (619) 453-9650

DESIGNED BY:

LD

DRAWN BY:

MSB

DATE:

12/7/94

BLOWER SYSTEM
INSTRUMENTATION DIAGRAM FOR AIR INJECTION
SITE 13115 - HEATING OIL UST
MCB CAMP PENDLETON, CALIFORNIA

ATTACHMENT B



Post Office Box 97
Benton Harbor, MI. 49023-0097
Ph: 616/926-6171
Fax: 616/925-8288

70-6100
F2-205/8/92
Rev. E

INSTALLATION AND OPERATING INSTRUCTIONS FOR GAST HAZARDOUS DUTY REGENAIR BLOWERS

This instruction applies to the following models ONLY: R3105N-50, R4110N-50, R4310P-50, R4P115N-50, R5125Q-50, R5325R-50, R6130Q-50, R6P155Q-50, R6350R-50, R6P355R-50 and R7100R-50.

Gast Authorized Service Facilities are Located in the locations listed below

Gast Manufacturing Corporation
505 Washington Avenue
Carlstadt, N. J. 07072
Ph: 201/933-8484
Fax: 201/933-5545

Gast Manufacturing Corporation
2550 Meadowbrook Road
Benton Harbor, MI. 49022
Ph: 616/926-6171
Fax: 616/925-8288

Brenner Fiedler & Associates
13824 Bentley Place
Cerritos, CA. 90701
Ph: 310/404-2721
Ph: 800/843-5558
Fax: 310/404-7975

Wainbee Limited
215 Brunswick Blvd.
Pointe Claire, Quebec
Canada H9R 4R7
Ph: 514/697-8810
Fax: 514/697-3070

Wainbee Limited
5789 Coopers Ave.
Mississauga, Ontario
Canada L4Z 3S6
Ph: 416 243-1900
Fax: 416 243-2336

Japan Machinery
Central PO Box 1451
Toyko 100-91, Japan
Ph: 813 3573-5421
Fax: 813 3571-7896

Gast Manufacturing Co. Ltd
Halifax Road, Cressex Estate
High Wycombe, Bucks HP12 3SN
England
Ph: 44 494 523571
Fax: 44 494 436588

SERVICING

⚠ WARNING To retain their sealed construction they should be serviced by Gast authorized service centers ONLY. These models are sealed at the factory for very low leakage.

⚠ WARNING Turn off electric power before removing blower from service. Be sure rotating parts have stopped. Electric shock or severe cuts can result. Inlet and exhaust filters attached to the blower may need cleaning or replacement of the elements. Failure to do so will result in more pressure drop, reduced air flow and hotter operation of the blower.

The outside of the unit requires cleaning of dust and dirt. The inside of the blower also may need cleaning to remove foreign material coating the impeller and housing. This should be done at a Gast Authorized Service Center. This buildup can cause vibration, failure of the motor to operate or reduced flow.

KEEP THIS INFORMATION WITH THIS BLOWER. REFER TO IT FOR SAFE INSTALLATION, OPERATION OR SERVICE.

MOTOR WIRING DIAGRAM FOR R4110N-50 & R3105N-50

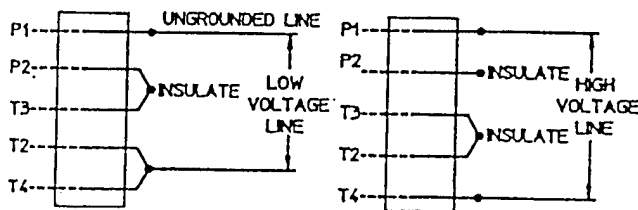

>> * WARNING
THIS MOTOR IS THERMALLY PROTECTED AND WILL AUTOMATICALLY RESTART WHEN PROTECTOR RESETS. ALWAYS DISCONNECT POWER SUPPLY BEFORE SERVICING.

MOTORS WIRING DIAGRAM FOR R4310P-50

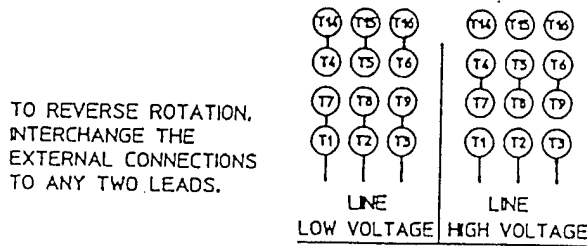

TO REVERSE ROTATION, INTERCHANGE THE EXTERNAL CONNECTIONS TO ANY TWO LEADS.

>> * WARNING
THIS MOTOR IS THERMALLY PROTECTED AND WILL AUTOMATICALLY RESTART WHEN PROTECTOR RESETS. ALWAYS DISCONNECT POWER SUPPLY BEFORE SERVICING.

MOTORS WIRING DIAGRAM FOR R5325R-50, R6350R-50, R6P355R-50, & R7100R-50

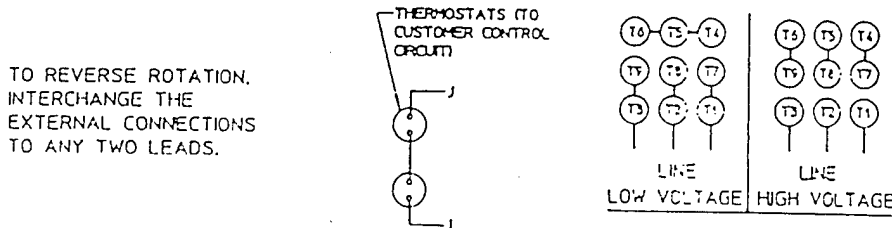

TO REVERSE ROTATION, INTERCHANGE THE EXTERNAL CONNECTIONS TO ANY TWO LEADS.

LINE LOW VOLTAGE HIGH VOLTAGE

REGENAIR® R4 Series

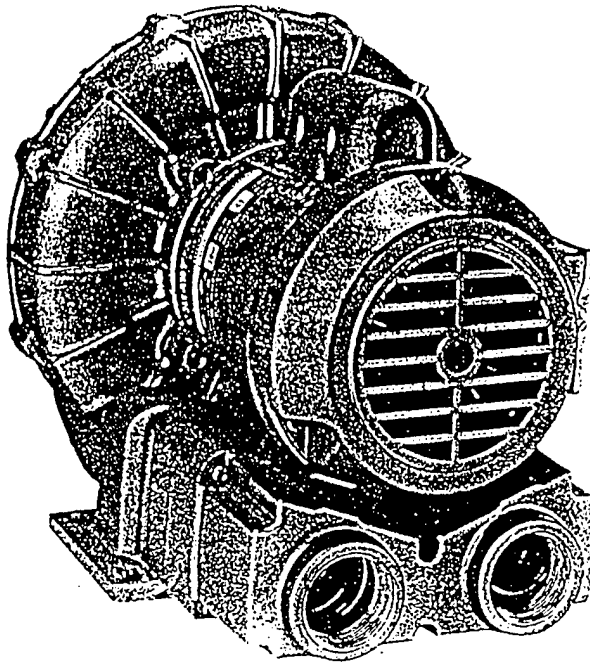

MODEL R4110-2
52" H₂O MAX. PRESSURE, 92 CFM OPEN FLOW

PRODUCT FEATURES

- Oilless operation
- TEFC motor mounted
- Can be mounted in any plane
- Rugged construction/low maintenance
- Can be operated blanked-off

COMMON MOTOR OPTIONS

- 115/208-230V, 60 Hz; 110/220-240V, 50 Hz, single phase
- 208-230/460V, 60 Hz; 190-230/380-415V, 50 Hz, three phase
- 575V, 60 Hz, three phase

RECOMMENDED ACCESSORIES

- Pressure gauge AJ496
- Filter AG338
- Muffler AJ121D
- Relief valve AG258

Various brand name motors are used on any model at the discretion of Gast Mfg. Corp.

Important Notice:

Pictorial and dimensional data is subject to change without notice.

Product Dimensions Metric (mm) U.S. Imperial (inches)

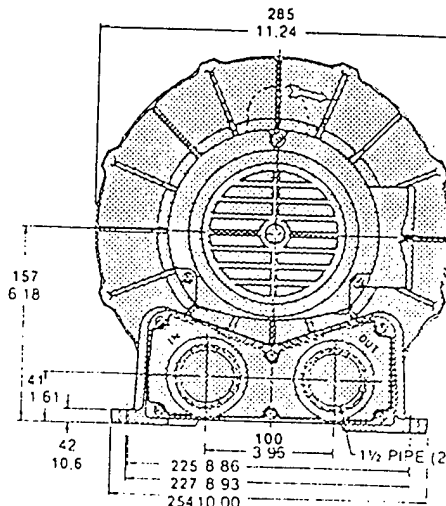
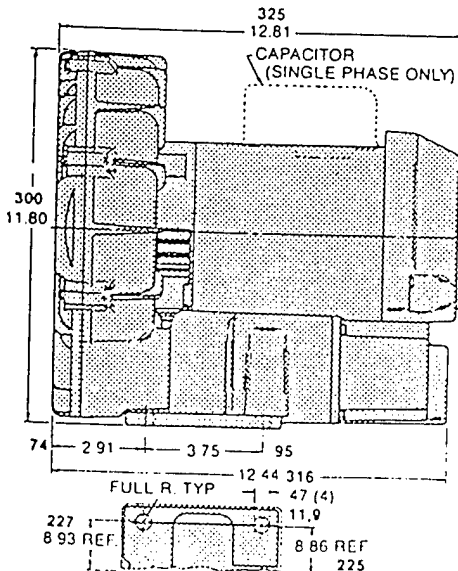

Product Specifications

Model Number	Motor Specs	Full Load Amps	HP	RPM	Max Pressure		Max Flow		Net Wt.	
					"H ₂ O	mbar	cfm	m ³ /h	lbs.	kg
R4110-2	110/220-240-50-1	9.0/4.5-5.7	0.6	2850	38	95	74	126	41	18,6
	115/208-230-60-1	9.8/5.2-4.9	1.0	3450	52	130	92	156		
R4310A-2	190-220/380-415-50-3	2.6-3.3/1.3-1.4	0.6	2850	38	95	74	126	41	18,6
	208-230/460-60-3	3.4-3.2/1.6	1.0	3450	52	130	92	156		

Product Performance (Metric U.S. Imperial) Black line on curve is for 60 cycle performance.
Blue line on curve is for 50 cycle performance.

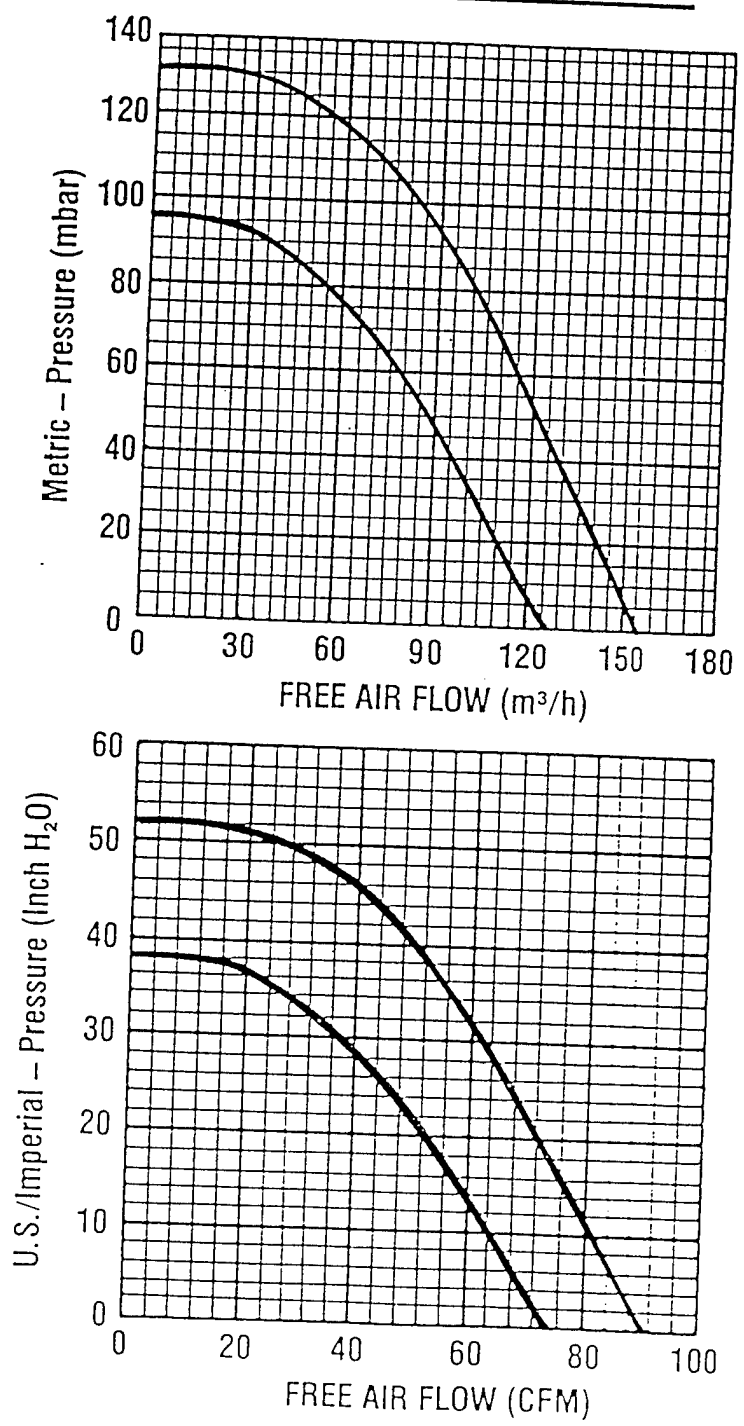

1st Q

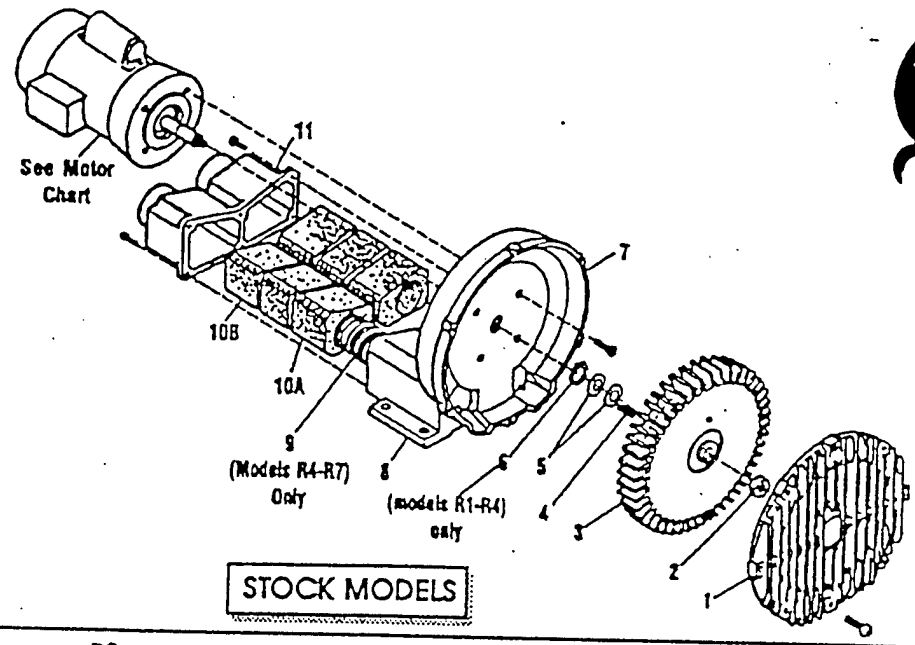

STOCK MODELS

Name	R1	R2	R3	R4	R5	R6	R6P	R6PP/R6PS	R7
Cover	AJ101A	AJ101B	AJ101C	AJ101D	AJ101EQ	AJ101F	AJ101K	(2)AJ101KA	AJ101G
Mount	BC187	BC187	BC181	BC181	BC181	BC181	BC181	(2)BC182	BC183
Impeller	AJ102A	AJ102BQ	AJ102C	AJ102D	AJ102E	AJ102FR	AJ102K	(2)AJ102KA	AJ102GA
Square Key	AH212C	AH212	AB136A	AB136D	AB136	AB136	AB136	(2)AB136	AC628
Spinn Spacer (s)	AJ132	AE686-3	AJ109	AJ109	AJ109	AJ116A	AJ116A	AJ116A	AJ110
Retaining Ring	AJ145	AJ145	AJ149	AJ149	AJ109	AJ116A	AJ116A	AJ116A	AJ110
Housing	AJ103A	AJ103BQ	AJ103C	AJ103DR	AJ103E	AJ103F	AJ103K	AJ103KD	AJ103GA
Muffler Box					AJ104E	AJ104F			
Spring				AJ113DR	AJ113DQ	AJ113FQ	AJ113FQ		
Adaptor	(4)AJ112A	(4)AJ112B	(4)AJ112C	(4)AJ112DS	(4)AJ112ER	(6)AJ112FI	(8)AJ112K		AJ113G
Blowam		(2)AJ112BQ	(2)AJ112CQ	(2)AJ112DR	(2)AJ112EQ				(8)AJ112GA
Muffler Extension/Adapter Plate	AJ106H	AJ106BQ	AJ106CQ	AJ106DQ	AJ106EQ	AJ106FQ	AJ104K		AJ104GA
Mount	K396	K396							K395

MOTOR CHART

EQUIPMENT MODEL NUMBER	MOTOR NUMBER	MOTOR SPECIFICATIONS			PHASE
		60 HZ VOLTS	50 HZ VOLTS		
102	J111X	115/208-230	110/220-240		1
102C	J112X	115			1
103	J311X	115/208-230	110/220		1
105	J411X	115/208-230	110/220		1
303A	J310	208-230/460	220/380-415		3
303F	J313	208-230	220		3
305-1/R3105-12	J411X	115/208-230	110/220-240		1
305A-1/R3305A-13	J410	208-230/460	220/380-415		3
110-2	J611AX	115/208-230	110/220-240		1
310A-2	J610	208-230/460	220/380-415		3
112-2	J811X	115/208-230			1
325A-2	J810X	208-230/460	220/380-415		3
125-2	J811X	115/208-230			1
335A-2	J810X	208-230/460	220/380-415		3
335A-2	J910X	208-230/460	220/380-415		3
150J-2	J1013	230			1
350A-2	J1010	208-230/460	220/380-415		3
350A	J910X	208-230/460	220/380-415		3
350A	J1010	208-230/460	220/380-415		3
355A	J1110A	208-230/460	220/380-415		3
100A-2	J1210B	208-230/460	220/380-415		3
360R6PS3110M	JD1100	208-230/460	220/380-415		3

* No lubrication needed at start up. Bearings lubricated at factory.

* Motor is equipped with alemite fitting. Clean tho of fitting and apply grease gun. Use 1 to 2 strokes of high quality ball bearing grease.

Consistency	Type	Typical Grease
Medium	Lithium	Shell Datum R

Hours of service per year	Suggested Relube Interval
5,000	3 years
Continual normal operation	1 year
Seasonal service motor idle for 3 months or more	1 year beginning of season
Continuous high ambient duty or most applications	6 months

60 HZ FLOW DATA (CFM)

All performance figures relate to stock models. A few high pressure units may be available. Consult your local distributor.

Regenair Model Number	P R E S S U R E						Maximum Pressure "H ₂ O"
	0"H ₂ O	20"H ₂ O	40"H ₂ O	60"H ₂ O	80"H ₂ O	100"H ₂ O	
R1	26	14					28
R2	42	26					38
R3105-1	52	38	14				42
R3105-12	52	36	23				55
R3305A-13	52	36	23				55
R4	70	70	50				52
R5	145	130	100				65
R6125-2	200	180					35
R6325A-2	200	180	152				40
R6335A-2	205	175	155	135			70
R6350A-2	200	180	150	130	110	80	105
R6P335A	290	250					30
R6P350A	300	260	230	200			60
R6P355A	300	260	230	200	160		90
R7100A-2	420	380	340	310	280	230	115
R6PP3110M	485	452	420	380	330		95
R6PS3110M	265	258	252	244	236	226	170

Regenair Model Number	V A C U U M						Maximum Vacuum "H ₂ O"
	0"H ₂ O	20"H ₂ O	40"H ₂ O	60"H ₂ O	80"H ₂ O		
R1	25	14					26
R2	40	22					34
R3105-1	50	34	9				40
R3105-12	51	34	20				50
R3305A-13	51	34	20				50
R4	82	62	39				48
R5	140	115	90	50			60
R6125-2	190	155	125				45
R6325A-2	190	155	125				45
R6335A-2	190	150	125	100			75
R6350A-2	190	180	150	100	70		90
R6P335A	270	230					37
R6P350A	280	240	210	170			70
R6P355A	280	240	210	170	100		86
R7100A-2	410	350	300	250	170		90
R6PP3110M	470	425	375	320	220		80
R6PS3110M	240	225	210	195	175	130	

This number indicates the maximum static pressure differential recommended (with cooling air still flowing through unit). In general, units 1hp or less can be dead headed. Check with local representative or distributor to verify which models apply.

Operation of the blower above the recommended maximum duty will cause premature failure due to the build up of heat damaging the components.

Performance data was determined under the following conditions:

- 1) Unit in a temperature stable condition.
- 2) Test conditions: Inlet air density of 0.075 lbs. per cubic foot. (20°C (68°F), 29.92 in. Hg (14.7PSIA)).
- 3) Normal performance variations on the resistance curve within +/- 10% of sub-rated data can be expected.
- 4) Specifications subject to change without notice.
- 5) All performance at 60-Hz operation.

APPENDIX B
GEOLOGIC LOGS AND CHAIN OF CUSTODY FORMS

Recovery (%)	TIP Background	TVH (ppm)	Blows/6"	Sample ID	DEPTH (ft)	USCS	SYMBOLS	MATERIALS DESCRIPTION
					0-4.5'	SM	[Symbol: Vertical lines]	SILTY SAND (SM): fill material, logged from drill cuttings
90	0.0	25	6/10/17		4.5-6.0'	CL	[Symbol: Horizontal lines]	4.5'-6.0' CLAY (CL): medium to high plasticity, dry, iron filled vertical fractures, weak to moderate petroleum odor, moderately hard, olive gray (5Y 5/3).
60	0.0	2	28/50-5"		6.0-9.5'	ML	[Symbol: Diagonal lines /]	9.5'-11.0' CLAYEY SILT (ML): low plasticity, moderately hard, dry, no fractures, weak hydrocarbon odor, light olive gray (5Y 6/2).
100	0.0	180	26/50		11.0-14.5'	ML	[Symbol: Diagonal lines /]	CLAYEY SILT (ML): Same as above.
					14.5-19.5'	SP	[Symbol: Dotted pattern]	14.5'-16.0' SAND (SP): fine to medium grained, 80% fine to poorly graded, dry, strong hydrocarbon odor, olive gray (5Y 5/2).
60	0.0	140	30/50-5"		19.5-24.5'	SP	[Symbol: Dotted pattern]	19.5'-21.0' SAND (SP): Same as above.
100	0.0	100	24/50		24.5-26.0'	SM-SP	[Symbol: Vertical lines]	24.5'-26.0' SILTY SAND AND POORLY GRADED SAND INTERLAYED (SM-SP): in 2" to 4" layers, SM fine grained, slightly to low plasticity fines, SP fine to medium grained, dry, strong hydrocarbon odor, trace of schist gravel, olive gray (5Y 5/2).
100	0.0	200	30/50		26.0-31.0'	SP-SM	[Symbol: Vertical lines]	31.0'-32.5' SAND WITH SILT (SP-SM): poorly graded, 90% fine to coarse grained sand, trace gravel, subangular schist clasts, 10% slightly plastic fines, dry, strong hydrocarbon odor, pale yellow (5Y 3/3).
100	0.0	0	44/50-3"		32.5-40.0'	SW-GW	[Symbol: Circles]	WELL GRADED SAND (SW) TO WELL GRADED GRAVEL (GW): 50% fine to coarse sand, 50% fine to coarse gravel, angular, dry, light olive gray (5Y 6/2) to very dark gray (5Y 3/1).
100	0.0	0	28/50		40.0-42.0'	SM	[Symbol: Vertical lines]	SAND WITH SILT (SP-SM): poorly sorted, 90% fine to medium sand, 10% slightly plastic fines, subangular, dry, no hydrocarbon odor, pale yellow (5Y 7/3).
					42.0-45.0'			TD at 42' bgs

All TVH readings were taken with a GasTech Tracetechlor meter.

Project	Camp Pendleton	Drill Company	Cal Pac
Location	Bldg 13115 Heating oil UST	Date Drilled	9/6/94
Job Number	722406.58040	Surface Elevation	Not Surveyed
Geologist	C. Loftenius	TOTAL DEPTH OF HOLE	42 feet bgs
Drill Rig	B-53 Hollow Stem Auger To 42'	Water Level	No Groundwater Encountered

Recovery (%)	TIP Background	TVH (ppm)	Blows/8"	Sample ID	DEPTH (ft)	USCS	SYMBOLS	MATERIALS DESCRIPTION
								SILTY SAND (SM): fill material, logged from soil cuttings.
100	0.0	46	7/9/18		5			4.5'-6.0' SANDY CLAY (CL): low to medium plasticity fines, moderately soft, dry, strong hydrocarbon odor, gray (5Y 5/1).
60	0.0	--	30/50-5"		10			9.5'-11.0' SANDY SILT (ML): 85% low plasticity fines, 15% fine sand, moderately soft, dry, light olive gray (5Y 6/2).
100	0.0	140	30/50		15			14.5'-15.0' SANDY SILT (ML): Same as above. 15.0'-16.0' SAND (SP): poorly graded, fine to medium grained, angular, dry, strong PHC odor, pale yellow (5Y 7/3). TD at 16' bgs.
					20			All TVH readings were taken with a GasTech Tracetehtor meter.

Project	Camp Pendleton	Drill Company	Cal Pac
Location	Bldg 13115 Heating oil UST	Date Drilled	9/6/94
Job Number	722406.58040	Surface Elevation	Not Surveyed
Geologist	C. Loftenius	TOTAL DEPTH OF HOLE	16 feet bgs
Drill Rig	B-53 Hollow Stem Auger To 16'	Water Level	No Groundwater Encountered

Recovery (%)	TIP Background	TVH (ppm)	Blows/8"	Sample ID	DEPTH (ft)	USCS	SYMBOLS	MATERIALS DESCRIPTION
						SM		SILTY SAND (SM): fill material, logged from soil cuttings.
90	0	70	12/28/50		5	CL		SILTY CLAY (CL): observed in drill cuttings, light olive gray
80	0	0	34/50-5"		10	ML		6.0'-7.5' CLAYEY SILT (ML): low plasticity, dry hard, pale olive (5Y 6/3), weak hydrocarbon odor, vertical fractures with black coating occur, coating has hydrocarbon odor.
100	0	0	28/50		15			12.0'-13.5' CLAYEY SILT (ML): same as above with 5% fines, no fractures.
100	0	0	32/50-5"		20	SP		16.0'-17.5' SAND (SP): poorly graded, 90% fine to medium grained sand, 10% coarse sand, coarse sand consists of shale to schist clasts, otherwise quartz grains, subangular to angular, dry, weak hydrocarbon odor, white (5Y 8/1).
100	0	160	40/60		25	SW		22.0'-23.5' SAND (SW): well graded, 90% fine to coarse sand, 10% fine gravel, angular, gravel clasts consist of black schist, hydrocarbon odor, light gray (5Y 7/1).
100	0	0	30/50-5"		30	ML		29.0'-30.0' SAND (SW): same as above.
					35			30.0'-30.5' CLAYEY SILT (ML): slightly to low plasticity fines, hard, dry, no hydrocarbon odor, light yellowish brown (2.5Y 6/3).
					35			34.0'-35.5' CLAYEY SILT (ML): same as above with 20% coarse subangular granite gravel clasts.
					40			TD at 35.5' bgs

All TVH readings were taken with a GasTech Tracetechnor meter.

Project	Camp Pendleton	Drill Company	Cal Pac
Location	Bldg 13115 Heating oil UST	Date Drilled	9/8/94
Job Number	722406.58040	Surface Elevation	Not Surveyed
Geologist	C. Loftenius	TOTAL DEPTH OF HOLE	35.5 feet bgs

Recovery (%)	TIP Background	TVH (ppm)	Blows/ft	Sample ID	DEPTH (ft)	USCS	SYMBOLS	MATERIALS DESCRIPTION
					5	SM		SILTY SAND (SM): fill material, logged from soil cuttings.
100	0	0	21/28/35		5	CL		SANDY CLAY (CL): observed in drill cuttings.
70	0	2	30/50-5"		10	SM		6.0'-6.5' SILTY SAND (SM): 70% fine to coarse sand, 30% slightly plastic fines, angular, dry, no hydrocarbon odor, light gray (5Y 7/2). 6.5'-7.5' SILTY SAND (SM): 80% fine to coarse sand, 15% non plastic fines, light gray (5Y 7/2).
100	0	2	35/58		15	ML		12.0'-13.5' SANDY SILT (ML): 65% slightly plastic fines, 35% fine sand, angular, dry, no hydrocarbon odor, roots occur in horizontal fractures, moderately hard, light gray (5Y 7/2).
100	0	0	30/56		20	SP		16.0'-17.5' SAND (SP): poorly graded, fine to medium grained sand, trace fines, subangular to angular, dry, no hydrocarbon odor, light gray (5Y 7/2).
90	0	0	50/50-5"		25	SP		22.0'-23.5' SAND (SP): same as above, poorly graded, 95% fine to coarse sand, 5% fine gravel, gravel clasts consist of schist.
80	0	0	36/50-5"		30	SW		29.0'-30.5' SAND WITH GRAVEL (SW): well graded, 85% fine to coarse sand, 10% fine gravel, 5% low plasticity fines, angular, gravel clasts consist of shale or schists, dry, no hydrocarbon odor, light gray (5Y 7/2).
					35	SM		34.0'-35.5' SILTY SAND (SM): 60% fine sand, 40% slightly plastic fines, angular, moderately hard, dry, no hydrocarbon odor, light gray (5Y 7/2). TD at 35.5' bgs
					40			All TVH readings were taken with a GasTech Tracetehtor meter.

Project <u>Camp Pendleton</u>	Drill Company <u>Cal Pac</u>
Location <u>Bldg 13115 Heating oil UST</u>	Date Drilled <u>9/7/94</u>
Job Number <u>722406.58040</u>	Surface Elevation <u>Not Surveyed</u>
Geologist <u>C. Loftenius</u>	TOTAL DEPTH OF HOLE <u>35.5 feet bgs</u>

Recovery (%)	TIP Background	TVH (ppm)	Blows/6"	Sample ID	DEPTH (ft)	USCS SYMBOLS	MATERIALS DESCRIPTION
							Asphalt
						SM	SILTY SAND (SM): fill material, logged from soil cuttings, olive (5Y 5/6).
						CL	SANDY CLAY (CL): 60% medium plasticity fines, 40% fine to medium sand, dry, moderately hard, no hydrocarbon odor, logged from soil cuttings, dark gray (5Y 7/1).
100	0	0	26/33/34		5	SM	
						SP	SILTY SAND (SM): 80% fine to medium sand, 20% low to medium plasticity, fines, subangular, dry, no hydrocarbon odor, logged from soil cuttings, light olive gray (5Y 6/2).
60	0	0	31/50		10		6.0'-7.5' SAND (SP): poorly graded, fine to coarse grained, trace fines, dry subangular, no hydrocarbon odor, light gray (5Y 7/2).
						ML	12.0'-13.5' SANDY SILT (ML): 60% slightly to low plasticity fines, 40% fine sand, angular, dry, moderately hard, no hydrocarbon odor, light olive gray (5Y 6/2).
100	0	0	36/50		15		
						SP	16.0'-17.5' SAND (SP): poorly graded, fine to medium grained sand, trace fines, dry, subangular, 90% quartz sand, no hydrocarbon odor, light gray (5Y 7/2).
100	0	0	31/50		20		
						SP	22.0'-23.5' SAND (SP): same as above, trace fine gravel, schist gravel clasts.
						SP	29.0'-30.5' SAND (SP): same as above.
100	0	0	36/50-5"		30		
						GW	34.0'-35.5' SANDY GRAVEL (GW): well graded, 70% fine to coarse gravel, 30% fine to coarse sand, trace fines, subangular to angular, gravel clasts consist of a mica schist, dry, no odor, friable, light olive gray (5Y 6/2).
25	0	0	50-5"		35		
							Total Depth = 35.5' bgs
							All TVH readings taken with a GasTech Tracetector meter.

Project	Camp Pendleton	Drill Company	Cal Pac
Location	Bldg 13115 Heating oil UST	Date Drilled	9/8/94
Job Number	722406.58040	Surface Elevation	Not Surveyed
Geologist	C. Loftenis	TOTAL DEPTH OF HOLE	35.5 feet bgs

Recovery (%)	TIP Background	TVH (ppm)	Blows/6"	Sample ID	DEPTH (ft)	USCS	SYMBOLS	MATERIALS DESCRIPTION
					0			SAND (SP): fill material, light gray (2.5Y 7/2), logged from drill cuttings.
					5			SANDY SILT (ML): logged from drill cuttings, light gray (5Y 7/2).
80	0	0	40/50-5"		10			9.0'-9.5' SANDY SILT (ML): 85% fine grained sand, 15% slightly plastic fines, subangular, dry, moderately hard, no hydrocarbon odor, pale olive (5Y 6/3).
100	0	0	29/50		15			9.5'-10.0' SAND (SP): poorly sorted, 100% fine to medium sand, dry, friable, no hydrocarbon odor, light gray (5y 7/2).
					15			13.0'-14.5' Same as above.
100	0	0	31/50		20			19.0'-20.5' SAND (SW): well graded, 95% fine to medium sand, quartz, 5% plastic fines, trace fine gravel, angular, dry, friable, no hydrocarbon odor, light gray (5Y 7/2).
100	0	0	27/40/50-4"		27			27.0'-27.5' SAND WITH COARSE GRAVEL AND SILT (SW-SM): 80% fine to coarse sand, 10% non-plastic fines, trace fine gravel, angular, dry, no hydrocarbon odor, friable, light gray (5Y 7/2).
					28			27.5'-28.5' SILT WITH SAND (ML): 90% slightly plastic fines, 10% fine sand, dry, moderately hard, no hydrocarbon odor, pale olive (5Y 6/4).
					30			TD at 30' bgs
					35			All TVH readings were taken with a GasTech Tracetehtor meter.

Project	Camp Pendleton	Drill Company	Cal Pac
Location	Bldg 13115 Heating oil UST	Date Drilled	9/8/94
Job Number	722406.58040	Surface Elevation	Not Surveyed
Geologist	C. Loftenius	TOTAL DEPTH OF HOLE	30 feet bgs
Sample	B-53 Hollow Stem Auger To 30'	water level	No Groundwater Encountered

CHAIN OF CUSTODY RECORD

740 909 680

PROJECT NO.		PROJECT NAME		NO. OF CONTAINERS		ANALYTICAL METHOD		REMARKS	
722406 58080		Camp Penetration, #10 venting Building 13115		1		Total Kjeldahl Nitrogen (TKN) vs EPA Method E351.2		Normal Turnaround Time 153670	
RELINQUISHED BY (SIGNATURE)		DATE		RECEIVED BY (SIGNATURE)		DATE		PRESERVATIVES	
<i>[Signature]</i>		9-8-94		<i>[Signature]</i>		9-8-94		None	
		TIME 1425				TIME 1425			
RELINQUISHED BY (SIGNATURE)		DATE		RECEIVED BY (SIGNATURE)		DATE		SEND RESULTS TO:	
<i>[Signature]</i>		9-9-94		<i>[Signature]</i>		9-9-94		RUC @ 108m temp. Mr Larry Budw's Engineering Science Inc. ES Denver	
		TIME 1425				TIME 1428			
RELINQUISHED BY (SIGNATURE)		DATE		RECEIVED BY (SIGNATURE)		DATE		SEND RESULTS TO:	
<i>[Signature]</i>		9-9-94		<i>[Signature]</i>		9-9-94		RUC @ 108m temp. Mr Larry Budw's Engineering Science Inc. ES Denver	
		TIME 1425				TIME 1428			