

LOAN DOCUMENT

PHOTOGRAPH THIS SHEET

0

INVENTORY

2 Part's

Bioventing Pilot Test Work Plan for ...

DOCUMENT IDENTIFICATION

Oct 93

DTIC ACCESSION NUMBER

LEVEL

DISTRIBUTION STATEMENT A

Approved for Public Release
Distribution Unlimited

DISTRIBUTION STATEMENT

[Empty box for Distribution Statement]

DATE ACCESSIONED

[Empty box for Date Returned]

DATE RETURNED

[Empty box for Registered or Certified Number]

REGISTERED OR CERTIFIED NUMBER

ACCESSION FOR	
NTIS	GRAM
DTIC	TRAC
UNANNOUNCED	
JUSTIFICATION	
BY	
DISTRIBUTION/	
AVAILABILITY CODES	
DISTRIBUTION	AVAILABILITY AND/OR SPECIAL
A-1	

DISTRIBUTION STAMP

20001127 007

DATE RECEIVED IN DTIC

PHOTOGRAPH THIS SHEET AND RETURN TO DTIC-FDAC

H
A
N
D
L
E

W
I
T
H

C
A
R
E

20001127 007

PART I

**Bioventing Pilot Test Work Plan for
Site FT-01 and Site SS-18
Little Rock AFB, Arkansas**

PART II

**Draft Interim Pilot Test Results Report for
Site FT-01 and Site SS-18
Little Rock AFB, Arkansas**

Prepared For

**Air Force Center for Environmental Excellence
Brooks AFB, Texas**

and

Little Rock AFB, Arkansas

ES

Engineering-Science, Inc.

October 1993

1700 BROADWAY, SUITE 900
DENVER, COLORADO 80290

ENGINEERING-SCIENCE

DEFENSE TECHNICAL INFORMATION CENTER REQUEST FOR SCIENTIFIC AND TECHNICAL REPORTS

Title AFCEE Collection

1. Report Availability (Please check one box)

- This report is available. Complete sections 2a - 2f.
- This report is not available. Complete section 3.

2a. Number of Copies Forwarded

1 each

2b. Forwarding Date

July/2000

2c. Distribution Statement (Please check ONE box)

DoD Directive 5230.24, "Distribution Statements on Technical Documents," 18 Mar 87, contains seven distribution statements, as described briefly below. Technical documents MUST be assigned a distribution statement.

- DISTRIBUTION STATEMENT A: Approved for public release. Distribution is unlimited.
- DISTRIBUTION STATEMENT B: Distribution authorized to U.S. Government Agencies only.
- DISTRIBUTION STATEMENT C: Distribution authorized to U.S. Government Agencies and their contractors.
- DISTRIBUTION STATEMENT D: Distribution authorized to U.S. Department of Defense (DoD) and U.S. DoD contractors only.
- DISTRIBUTION STATEMENT E: Distribution authorized to U.S. Department of Defense (DoD) components only.
- DISTRIBUTION STATEMENT F: Further dissemination only as directed by the controlling DoD office indicated below or by higher authority.
- DISTRIBUTION STATEMENT X: Distribution authorized to U.S. Government agencies and private individuals or enterprises eligible to obtain export-controlled technical data in accordance with DoD Directive 5230.25, Withholding of Unclassified Technical Data from Public Disclosure, 6 Nov 84.

2d. Reason For the Above Distribution Statement (in accordance with DoD Directive 5230.24)

2e. Controlling Office

HQ AFCEG

2f. Date of Distribution Statement Determination

15 Nov 2000

3. This report is NOT forwarded for the following reasons. (Please check appropriate box)

- It was previously forwarded to DTIC on (date) and the AD number is
- It will be published at a later date. Enter approximate date if known.
- In accordance with the provisions of DoD Directive 3200.12, the requested document is not supplied because:

Print or Type Name

Laura Peña

Telephone

210-536-1431

Signature

Laura Peña

(FOR DTIC USE ONLY)

AQ Number

M01-01-0346

PART I
BIOVENTING PILOT TEST WORK PLAN FOR
SITE FT-01 AND SITE SS-18
LITTLE ROCK AFB, ARKANSAS

Prepared for:

Air Force Center for Environmental Excellence
Brooks AFB, Texas

and

Little Rock AFB, Arkansas

Prepared by:

Engineering-Science, Inc.
1700 Broadway, Suite 900
Denver, Colorado 80290

October 1993

**BIOVENTING PILOT TEST WORK PLAN FOR
SITE FT-01 AND SITE SS-18
LITTLE ROCK AFB, ARKANSAS**

Prepared for:

**Air Force Center for Environmental Excellence
Brooks AFB, Texas**

and

Little Rock AFB, Arkansas

Prepared by:

**Engineering-Science, Inc.
1700 Broadway, Suite 900
Denver, Colorado 80209**

October 1993

CONTENTS

PART I - BIOVENTING PILOT TEST WORK PLAN FOR SITE FT-01 AND SITE SS-18 LITTLE ROCK AFB, ARKANSAS

	<u>Page</u>
1.0 Introduction	I-1
2.0 Site Description	I-2
2.1 Site FT-01, Fire Protection Training Area	I-2
2.1.1 Site History and Location	I-2
2.1.2 Site Geology.....	I-2
2.1.3 Site Contaminants	I-2
2.2 Site SS-18, Jet Fuel Release	I-5
2.2.1 History and Location.....	I-5
2.2.2 Site Geology.....	I-5
2.2.3 Site Contaminants	I-5
3.0 Pilot Test Activities	I-5
3.1 Bioventing Test Design for Site FT-01.....	I-7
3.2 Site SS-18.....	I-9
3.3 Background Well	I-14
3.4 Handling of Drill Cuttings	I-14
3.5 Soil and Soil Gas Sampling	I-14
3.5.1 Soil Samples.....	I-14
3.5.2 Soil Gas Samples	I-16
3.6 Blower System	I-16
3.7 In Situ Respiration Tests	I-16
3.8 Air Permeability Tests	I-18
3.9 Potential For Air Emissions.....	I-18
3.10 Extended Pilot Test Bioventing System	I-18
4.0 Exceptions to Protocol Procedures.....	I-19
5.0 Base Support Requirements	I-19
6.0 Project Schedule.....	I-20
7.0 Points of Contact	I-20
8.0 References.....	I-20

FIGURES

<u>No.</u>	<u>Title</u>	<u>Page</u>
2.1	Sites FT-01 and SS-18 Site Locations	I-3
2.2	Site FT-01 Soil Gas Sample Locations Fire Protection Training Area	I-4

CONTENTS (Continued)

FIGURES (Continued)

<u>No.</u>	<u>Title</u>	<u>Page</u>
2.3	Site SS-18 Soil Gas Sample Locations Jet Fuel Release	I-6
3.1	Site FT-01 Proposed Vent Well/Monitoring Point Locations	I-8
3.2	Site FT-01 Proposed Injection Vent Well Construction Detail	I-10
3.3	Site FT-01 Proposed Monitoring Point Construction Detail	I-11
3.4	Site SS-18 Proposed Vent Well/Monitoring Point Locations	I-12
3.5	Site SS-18 Proposed Injection Vent Well Construction Detail	I-13
3.6	Site SS-18 Proposed Monitoring Point Construction Detail	I-15
3.7	Blower System Instrumentation Diagram for Air Injection	I-17

PART I

**BIOVENTING PILOT TEST WORK PLAN FOR
SITE FT-01 AND SITE SS-18
LITTLE ROCK AFB, ARKANSAS**

1.0 INTRODUCTION

This work plan presents the scope of multiphase bioventing pilot tests for *in situ* treatment of fuel-contaminated soils at Site FT-01, fire training area, and Site SS-18 at Little Rock Air Force Base (AFB), Arkansas. The pilot tests will be performed by Engineering-Science, Inc. (ES). The three primary objectives of the proposed pilot tests are: 1) to assess the potential for supplying oxygen throughout the contaminated soil interval, 2) to determine the rate at which indigenous microorganisms will degrade fuel when supplied with oxygen-rich soil gas, and 3) to evaluate the potential for sustaining these rates of biodegradation until fuel contamination is remediated to concentrations below regulatory standards.

The pilot tests will be conducted in two phases. A vent well (VW) and vapor monitoring points (MPs) will be installed during site investigation activities. The initial test phase at each site will also include an *in situ* respiration test, an air permeability test, and installation of a blower system for air injection. This initial testing is expected to take approximately 2 weeks. If the initial phase is successful, the second phase will begin immediately. During the second phase, the bioventing systems will be operated and monitored over a 1-year period.

Based on existing site characterization work, sites FT-01 and SS-18 appear to have very clayey soils with low permeability. Due to this low permeability, ES will perform the initial phase test at Site FT-01. If successful, the initial phase of testing will be performed at the second site, SS-18.

If bioventing proves to be an effective means of remediating soil contamination at these sites, pilot test data may be used to design full-scale remediation systems and to estimate the time required for site cleanup. An added benefit of the pilot testing at Site FT-01 and Site SS-18 is that a significant amount of the fuel contamination should be biodegraded during the 1-year pilot test, as the testing will take place within the most contaminated soils at the sites. Additional background information on the development and recent success of the bioventing technology is found in the document entitled *Test Plan and Technical Protocol for a Field Treatability Test for Bioventing* (Hinchee et al., 1992). This protocol document will serve as the primary reference for pilot test well designs and the detailed procedures to be used during the test.

2.0 SITE DESCRIPTION

2.1 Site FT-01, Fire Protection Training Area

2.1.1 Site History and Location

Site FT-01 is located within a semi-restricted area south of the eastern taxiway (Figure 2.1). The area is fenced on the west and north by restricted runway operation areas. Unrestricted access can only be gained on foot from the east side.

Site FT-01 has been used at the Base for fire training exercises since 1955. From 1955 to approximately 1970, fuel, waste solvents, hydraulic oils, and other combustible materials (up to 2,000 gallons per exercise) were poured on mock-up airplanes and burned. During this period, burning was conducted on the west side of the asphalt road which transects the site (Figure 2.2). In 1970, burning activities were moved to the east side of the asphalt road. At this time the burn materials became limited to contaminated jet fuel only. Approximately 600 gallons of jet fuel were used per exercise, which were usually conducted on a bimonthly basis. The Base stopped open burning during their fire training exercises in 1990, but continues to use the area east of the asphalt road for training purposes. Only the current burn area shows visual signs of surface contamination. (CDM Federal Programs Corporation 1993).

2.1.2 Site Geology

Because the bioventing technology is applied to the unsaturated soils, this section primarily addresses soils above the shallow aquifer. Depth to bedrock (Atoka shale) at Site FT-01 ranges from 10 to 20 feet below ground surface (bgs). Light olive-gray to brownish, moist clay comprises the unconsolidated deposits above the Atoka Formation. These clays also contain high percentages of silt and sand (CDM Federal Programs Corporation, 1992).

The inferred potentiometric gradient suggests that groundwater flow direction is to the east/northeast. During well installation, groundwater was encountered at depths ranging from 5 to 27 feet bgs. Based on groundwater level monitoring results, the depth to groundwater fluctuates throughout the year. ES anticipates the water levels in the vicinity of the proposed bioventing system installation will be approximately 10 feet bgs during the summer months.

2.1.3 Site Contaminants

Thirty-four soil gas samples were collected at Site FT-01 during November 1991 (Figure 2.2). Several soil gas samples contained elevated concentrations of total volatile petroleum hydrocarbons (TVH). The TVH concentrations ranged from 21 to 42,000 micrograms per liter ($\mu\text{g/L}$), and measurable levels of toluene, ethylbenzene, and xylenes were also detected in some of the samples. Benzene was not detected in any of the samples. Toluene was detected in sample 3-2 (240 $\mu\text{g/L}$), and ethylbenzene was detected at 760 $\mu\text{g/L}$ and 180 $\mu\text{g/L}$ in samples 3-1 and 5-2,

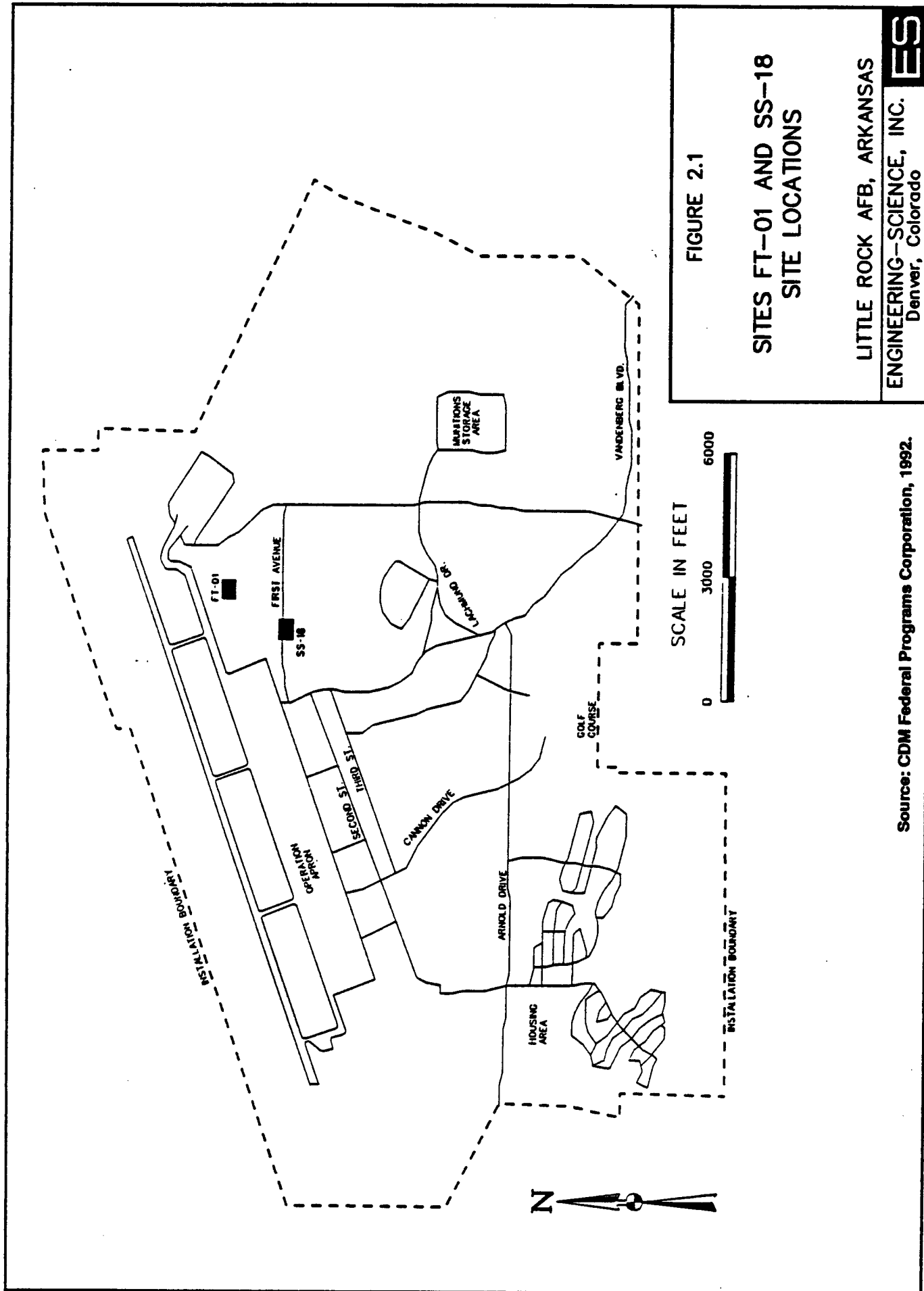

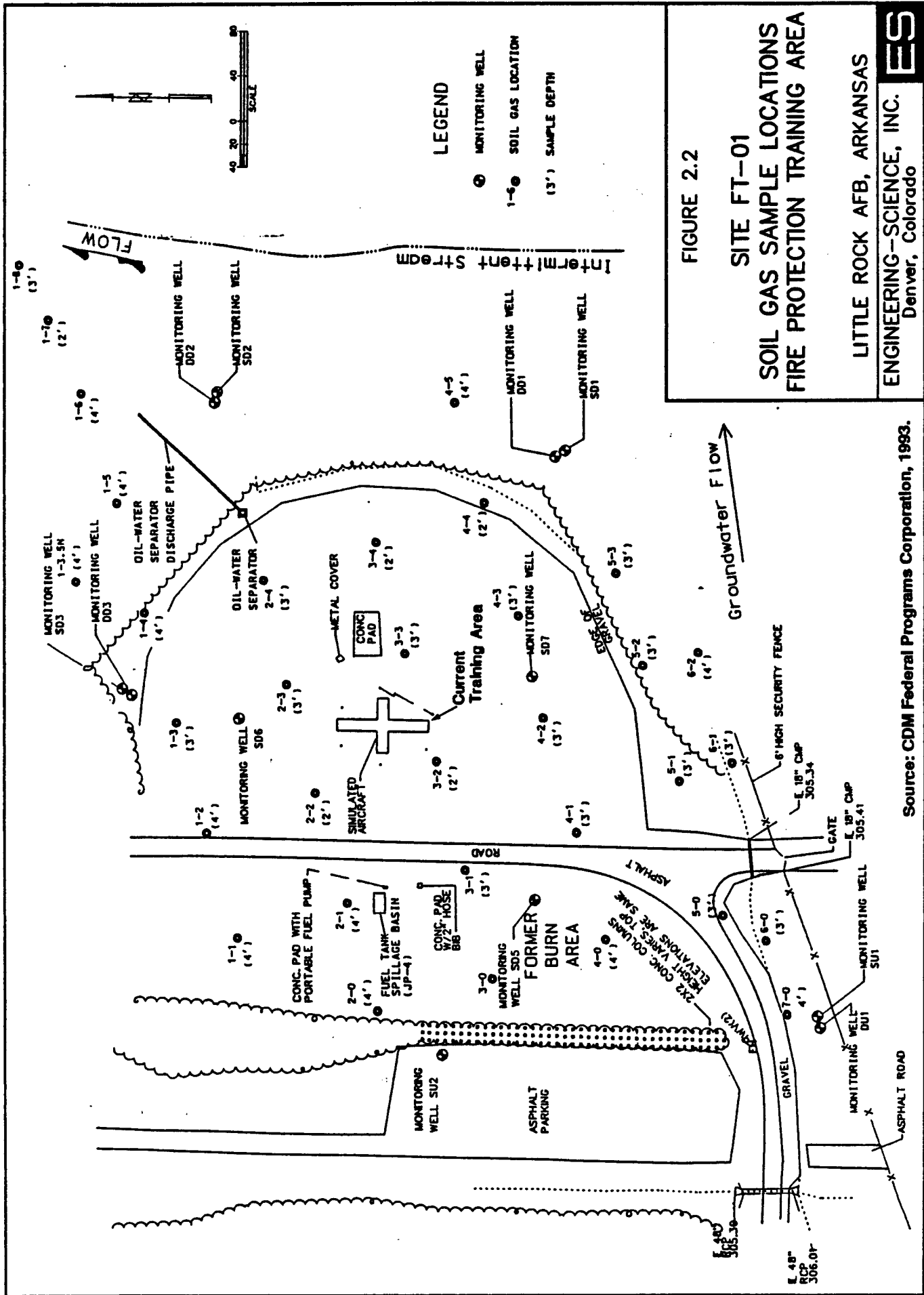

Source: CDM Federal Programs Corporation, 1993.

respectively (Figure 2.2). Total xylenes were detected at concentrations ranging from 3 to 530 $\mu\text{g}/\text{L}$ in six samples (CDM Federal Programs Corporation, 1993).

Soil sampling showed total recoverable petroleum hydrocarbons (TRPH) concentrations ranging from 68 to 1600 milligrams per kilogram (mg/kg). Ethylbenzene, toluene, and xylenes were detected at concentrations of 43, 82, and 480 $\mu\text{g}/\text{kg}$ respectively (CDM Federal Programs Corporation, 1993).

2.2 Site SS-18, Jet Fuel Release

2.2.1 History and Location

Site SS-18 is located approximately 0.25 mile south-southwest of site FT-01, and immediately south of First Avenue (Figure 2.1). Two 10-inch underground jet fuel (JP-4) pipelines intersect the site. The dual pipelines transfer fuel from the bulk fuel storage area to the flight line hydrant system north of the site. In 1987, large pools of JP-4 fuel were observed in low-lying areas to the north and south of the valve vaults located approximately 200 feet south of First Street (Figure 2.3). The spill appeared to be the result of a failure to close valves during a routine pipeline cleaning. An estimated 2,000-gallons of JP-4 was recovered from a drainage ditch along the south side of First Street and from a pond located south of the two valve vaults. An Installation Restoration Program (IRP) Stage 1 investigation soil gas survey of the vadose zone indicated that the contamination was limited to a narrow area within 50 to 100 feet on either side of the roads leading north and south from First Street (CDM Federal Programs Corporation 1992).

2.2.2 Site Geology

The geology of Site SS-18 is similar to that of Site FT-01 (Section 2.1.2), with the addition of larger cobbles and more shallow bedrock. Bedrock is encountered at a depth of approximately 5 feet bgs, above which groundwater is encountered (CDM Federal Programs Corporation 1992).

2.2.3 Site Contaminants

Twenty-six (26) soil gas samples were collected from 22 sampling locations at site SS-18 during November 1991 (Figure 2.3). Thirteen samples contained significant TVH contamination. A maximum TVH concentration of 3,200 $\mu\text{g}/\text{L}$ was detected in sample 1-5, located approximately 115 feet north of First Street. Soil sampling yielded TRPH concentrations ranging from 73 to 2063 mg/kg. Xylenes (0.21 to 0.52 mg/kg) and 2-butanone (0.13 to 0.24 mg/kg) were also detected in soil samples. Groundwater samples contained benzene (37 $\mu\text{g}/\text{L}$) and TRPH (2 mg/L). Contamination is believed to be limited to a narrow area within 50 to 100 feet on either side of the roads leading north and south from First Street. However, the contamination appears to be more concentrated in the area north of First Street (CDM Federal Programs Corporation 1992).

3.0 PILOT TEST ACTIVITIES

The purpose of this section is to describe the pilot test activities to take place at Site FT-01 and Site SS-18. The proposed locations and construction details for the

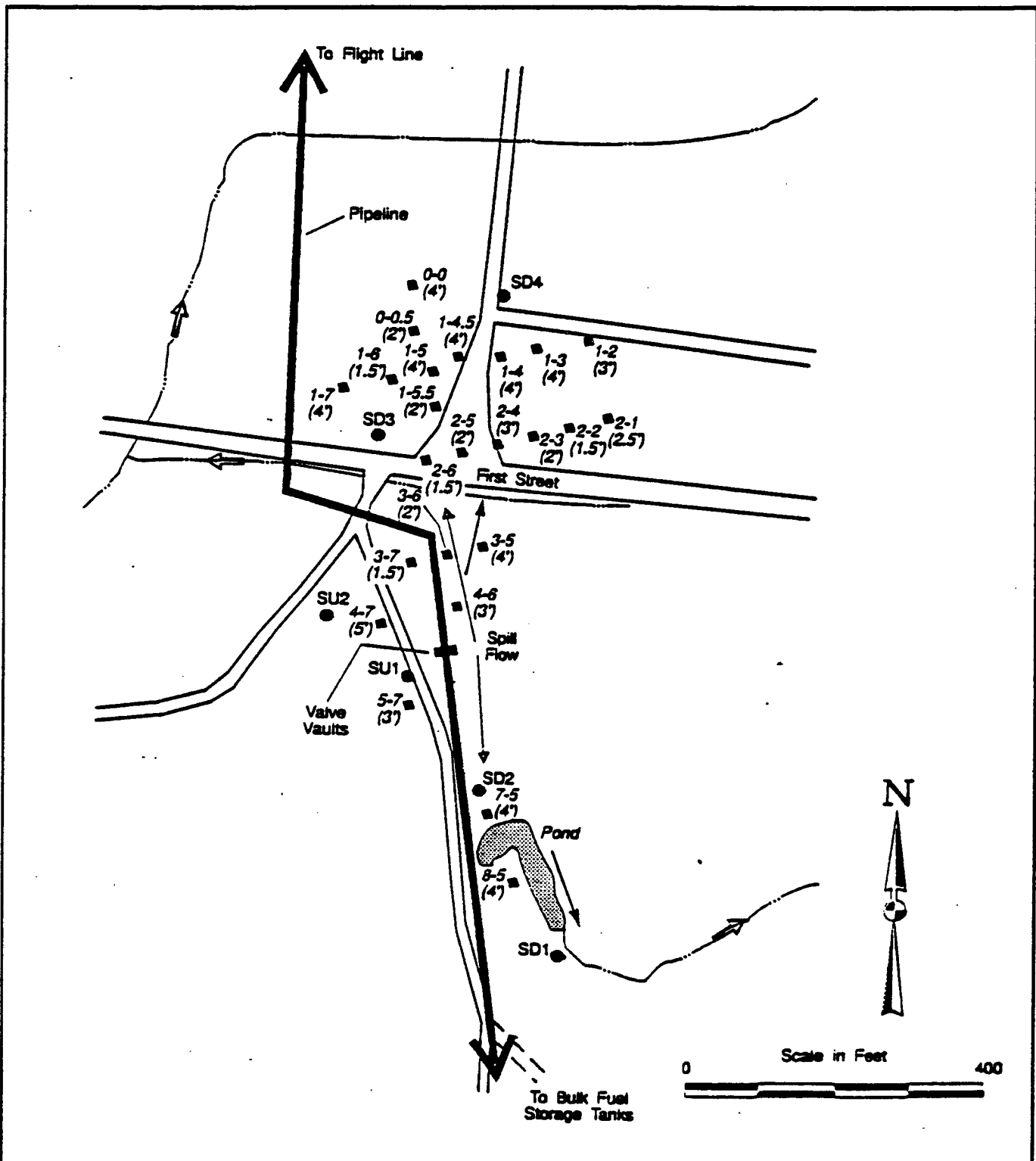

LEGEND

- General direction of groundwater flow as determined by USGS
- Monitoring Well
- Soil Gas Location (Sample Depth)
- Drainage

FIGURE 2.3

SITE SS-18
SOIL GAS SAMPLE LOCATIONS
JET FUEL RELEASE

LITTLE ROCK AFB, ARKANSAS

ENGINEERING-SCIENCE, INC.
 Denver, Colorado

Source: CDM Federal Programs Corporation, 1982.

central VWs and vapor MPs are discussed. Criteria for locating a suitable background well position are outlined. Soil and soil gas sampling procedures and the blower configuration that will be used to inject air (oxygen) into contaminated soils are also discussed in this section. Finally, a brief description of the pilot test procedures is provided.

The bioventing technology is intended to remediate contamination only in the unsaturated zone. Therefore, pilot test activities will be confined mainly to unsaturated soils. The central VWs may be completed to a depth of 10 feet below the anticipated groundwater level at the time of installation. This is to provide oxygen to the deepest levels of the unsaturated zone, in case the groundwater table recedes due to pressurization or natural fluctuation. Because groundwater and bedrock are so shallow at these sites, the installation and first phase of pilot testing will occur during the summer months, when groundwater is anticipated to be at its lowest. Also, during the extended pilot testing, ES realizes that some of the screened interval may be below the water table. This will not harm the system and will allow the system to work in the capillary fringe during the dry season. No dewatering will take place during the pilot tests.

Existing monitoring wells will not be used as primary air injection wells. However, monitoring wells which have a portion of their screened interval above the water table may be used as vapor MPs or to measure the composition of background soil gas. Additionally, before beginning drilling, a soil gas survey will be performed to locate the most contaminated and therefore most oxygen depleted area of the sites.

3.1 Bioventing Test Design for Site FT-01

A general description of criteria for siting a central VW and vapor MPs is included in the protocol document (Hinchee et al., 1992). Figure 3.1 illustrates the proposed locations of the central VW and MPs at this site. The final locations of these wells may vary slightly from the proposed locations if significant fuel contamination is not observed in the boring for the central VW. Soils in this area are expected to be TRPH contaminated and oxygen depleted (<2%), and biological activity should be stimulated by oxygen-rich soil gas ventilation during pilot test operations.

Due to the relatively shallow depth of contamination at this site and the potential for low-permeability soils, the potential radius of venting influence around the central VW is expected to be 20 to 30 feet. Three vapor MPs (MPA, MPB, and MPC) will be located within a 25-foot radius of the central VW.

The VW will be constructed of 4-inch-diameter Schedule 40 polyvinyl chloride (PVC) casing, with a 10-foot interval of 0.04-inch slotted screen set at 4 to 14 feet bgs. Flush-threaded PVC casing and screen with no organic solvents or glues will be used. The filter pack will be clean, well-rounded silica sand with a 6-9 grain size and will be placed in the annular space to 1 foot above the screened interval. A 3-foot layer of bentonite will be placed directly over the filter pack. The first 6 inches of bentonite will consist of bentonite pellets hydrated in place with potable water. This layer of pellets will prevent the addition of bentonite slurry from saturating the filter

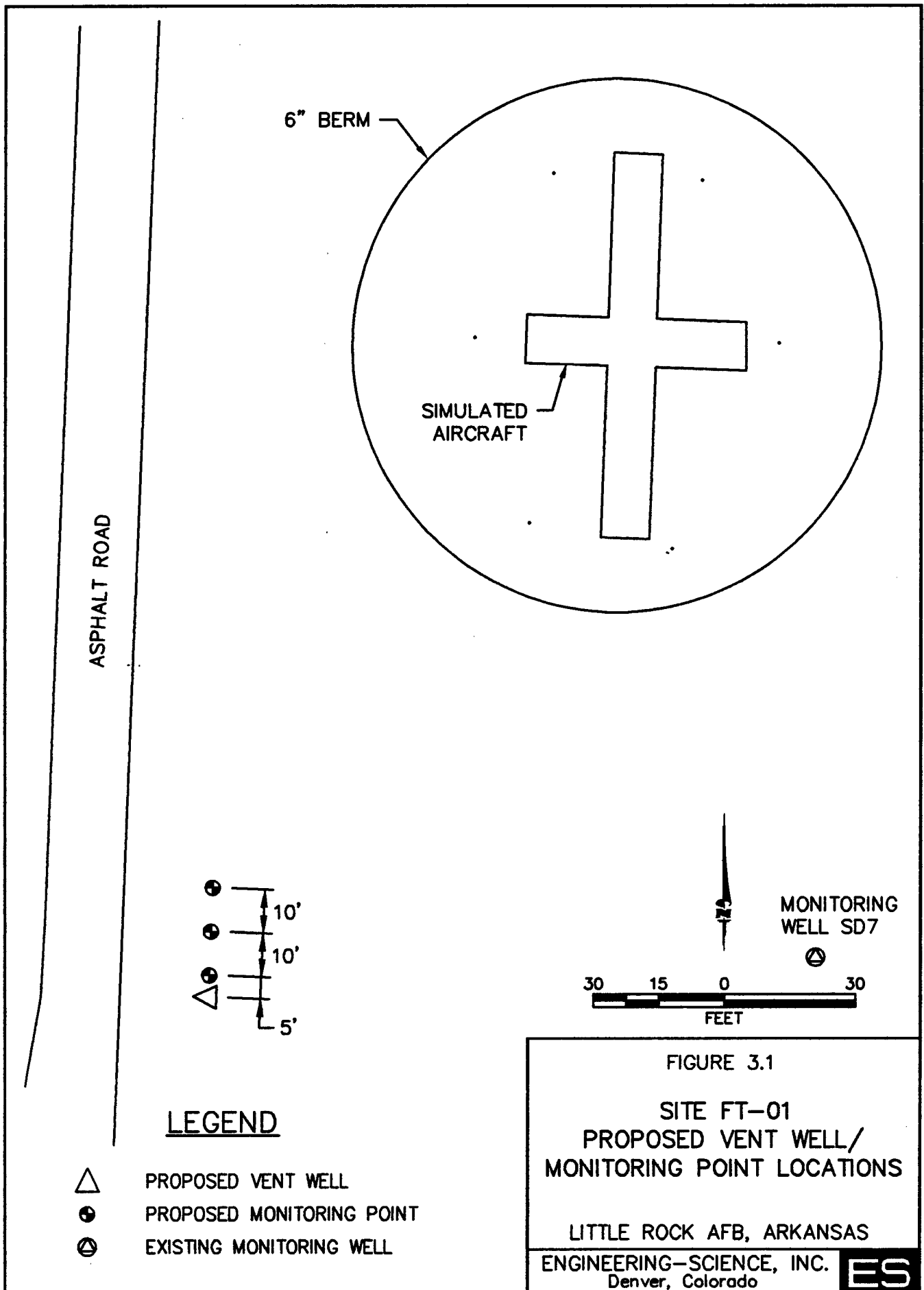

ASPHALT ROAD

6" BERM

SIMULATED AIRCRAFT

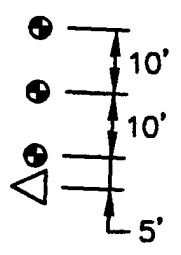

LEGEND

- △ PROPOSED VENT WELL
- PROPOSED MONITORING POINT
- ⊙ EXISTING MONITORING WELL

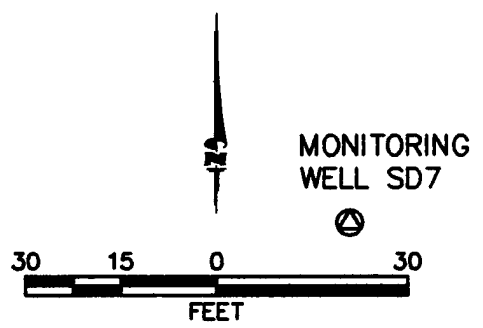

FIGURE 3.1
 SITE FT-01
 PROPOSED VENT WELL/
 MONITORING POINT LOCATIONS
 LITTLE ROCK AFB, ARKANSAS
 ENGINEERING-SCIENCE, INC.
 Denver, Colorado **ES**

pack. The remaining 30 inches of bentonite will be fully hydrated and mixed aboveground, and the slurry will be tremmied into the annular space to produce an air-tight seal above the screened interval. The borehole will then be completed to the ground surface with a bentonite/cement grout. A complete seal is critical to prevent injected air from short-circuiting to the surface during the bioventing test. Figure 3.2 illustrates the proposed central VW construction detail for this site.

A typical multi-depth vapor MP installation for this site is shown in Figure 3.3. Soil gas oxygen and carbon dioxide concentrations will be monitored at depths of 4 to 5 feet, and 7 to 8 feet at each location. Multi-depth monitoring will confirm that the entire soil profile is receiving oxygen and will be used to measure fuel biodegradation rates at the two depths. The annular spaces between the two screened MP intervals will be sealed with bentonite to isolate the monitoring intervals. However, if groundwater levels remain high, only the upper MP will be used for monitoring during initial pilot testing. As with the central VW, several inches of bentonite pellets will be used to shield the filter pack from rapid infiltration of bentonite slurry additions. Thermocouples will be installed at both depths on MPA to measure soil temperature. Additional details on VW and MP construction are presented in Section 4 of the protocol document (Hinchee et al., 1992).

3.2 Site SS-18

Figure 3.4 illustrates the proposed locations of the central VW and MPs at this site. The final location of these wells may vary slightly from the proposed location if significant fuel contamination is not observed in the boring for the central VW. Soils in this area are expected to have an average TRPH concentration exceeding 1,000 mg/kg, and to be oxygen depleted (<2%). Biological activity should be stimulated by oxygen-rich soil gas ventilation during pilot test operations.

Due to the relatively shallow depth of contamination at this site and the potential for low-permeability soils, the potential radius of influence around the central VW is expected to be 20 to 30 feet. Three vapor MPs (MP1, MP2, and MP3) will be located within a 25 feet radius of the central VW.

The VW will be constructed of 4-inch-diameter Schedule 40 PVC, with a 10-foot interval of 0.04-inch slotted screen set at 4 to 14 feet bgs. Flush-threaded PVC casing and screen with no organic solvents or glues will be used. The filter pack will be clean, well-rounded silica sand with a 6-9 grain size and will be placed in the annular space to one foot above the screened interval. A 3-foot layer of bentonite will be placed directly over the filter pack. The first 6 inches of bentonite will consist of bentonite pellets hydrated in place with potable water. This layer of pellets will prevent the rapid addition of bentonite slurry from saturating the upper portion of the filter pack. The remaining 30 inches of bentonite will be fully hydrated and mixed aboveground, and then tremmied into the annular space to produce an air-tight seal above the screened interval that will prevent injected air from short-circuiting to the surface during the bioventing test. The well will be completed to the ground surface with a bentonite/cement grout. Figure 3.5 illustrates the proposed central VW construction for this site.

2" DIAMETER SCH 40
PVC HEADER SLOPED
TO WELL

← FROM BLOWER

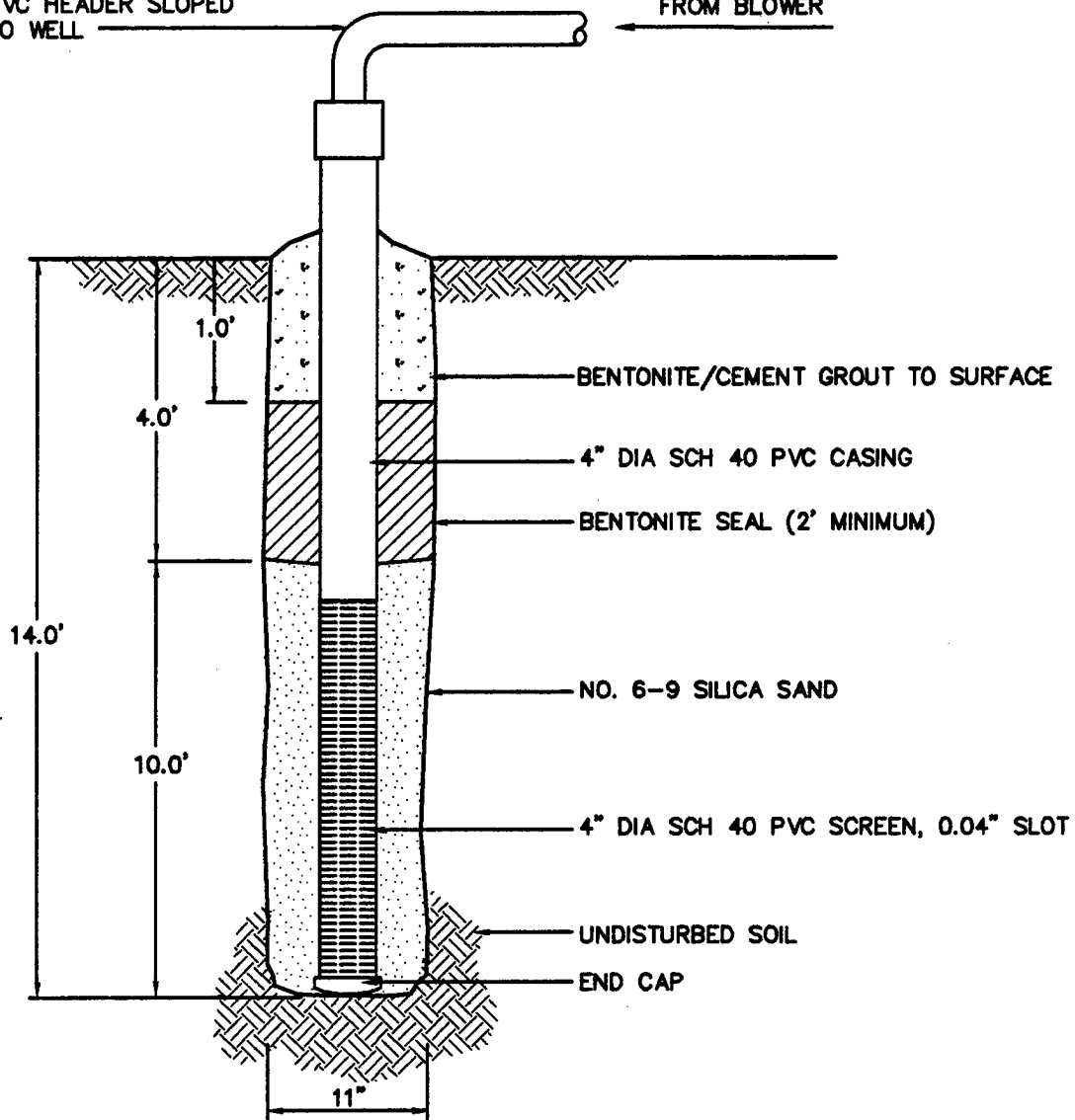

NOT TO SCALE

FIGURE 3.2

SITE FT-01
PROPOSED INJECTION VENT WELL
CONSTRUCTION DETAIL

LITTLE ROCK AFB, ARKANSAS

ENGINEERING-SCIENCE, INC.
Denver, Colorado

ES

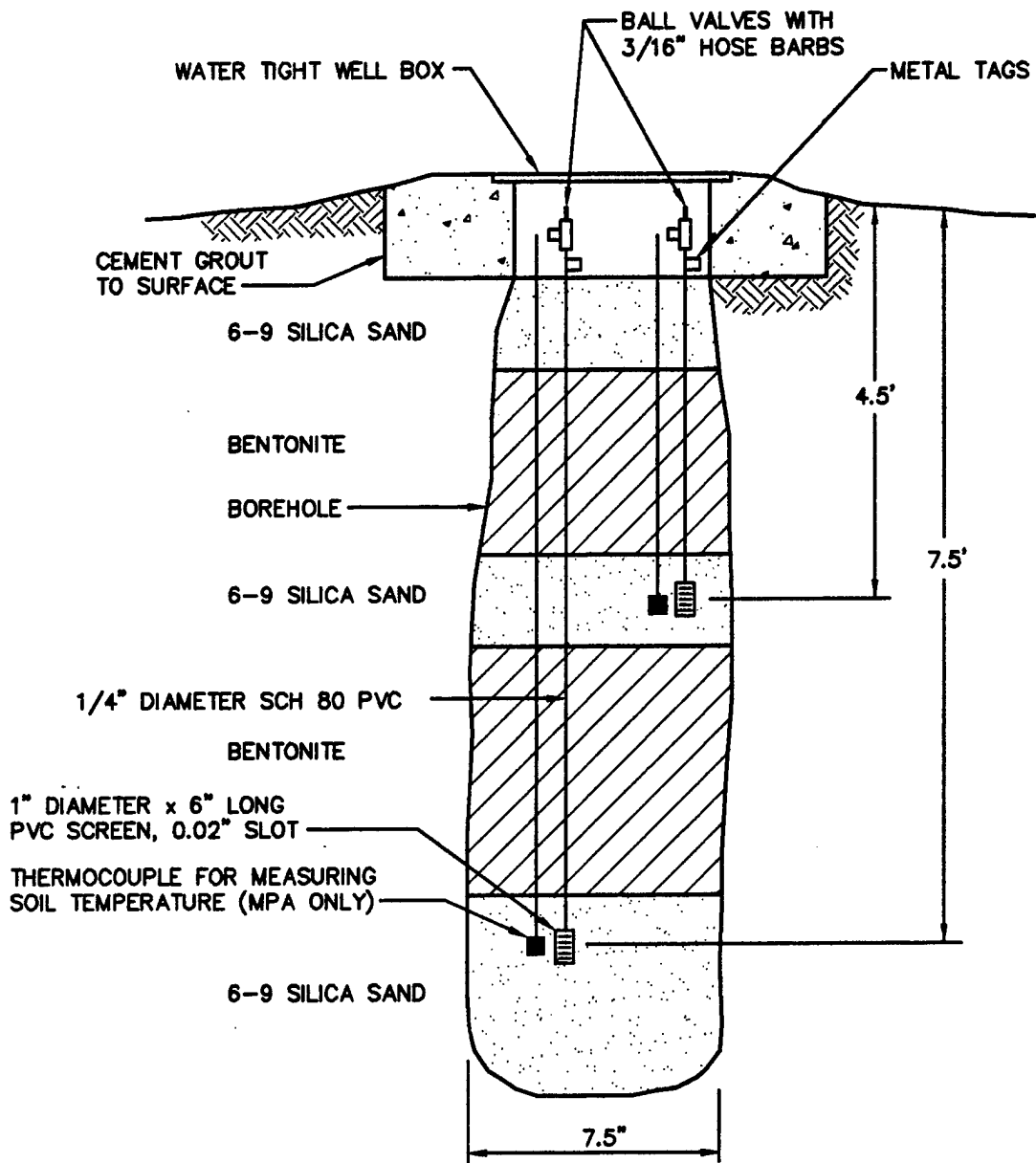

FIGURE 3.3

SITE FT-01
 PROPOSED MONITORING POINT
 CONSTRUCTION DETAIL

LITTLE ROCK AFB, ARKANSAS

ENGINEERING-SCIENCE, INC.
 Denver, Colorado



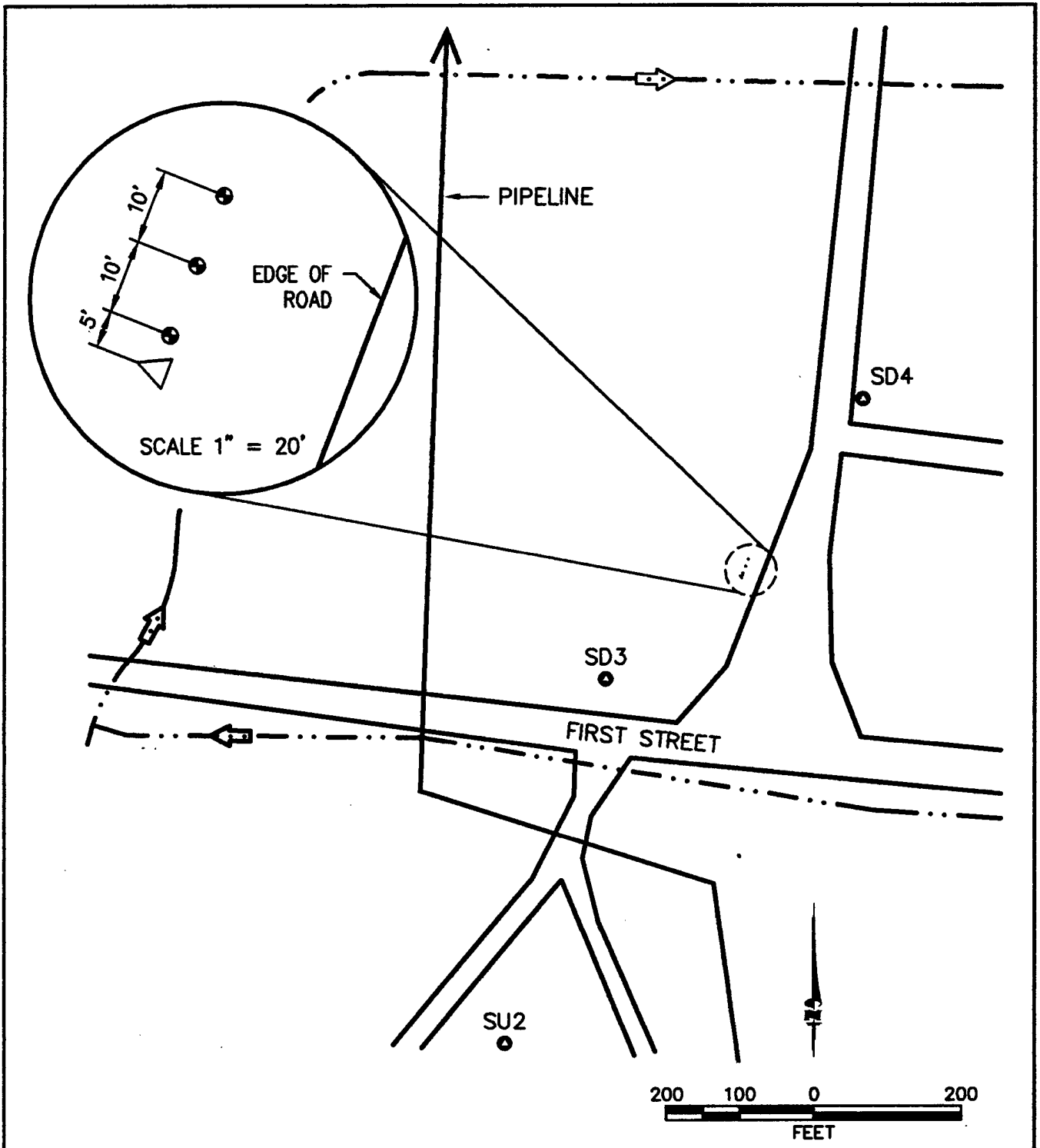

LEGEND

- △ PROPOSED VENT WELL
- PROPOSED MONITORING POINT
- EXISTING MONITORING WELL

FIGURE 3.4
 SITE SS-18
 PROPOSED VENT WELL/
 MONITORING POINT LOCATIONS
 LITTLE ROCK AFB, ARKANSAS
 ENGINEERING-SCIENCE, INC.
 Denver, Colorado **ES**

2" DIAMETER SCH 40
PVC HEADER SLOPED
TO WELL

FROM BLOWER

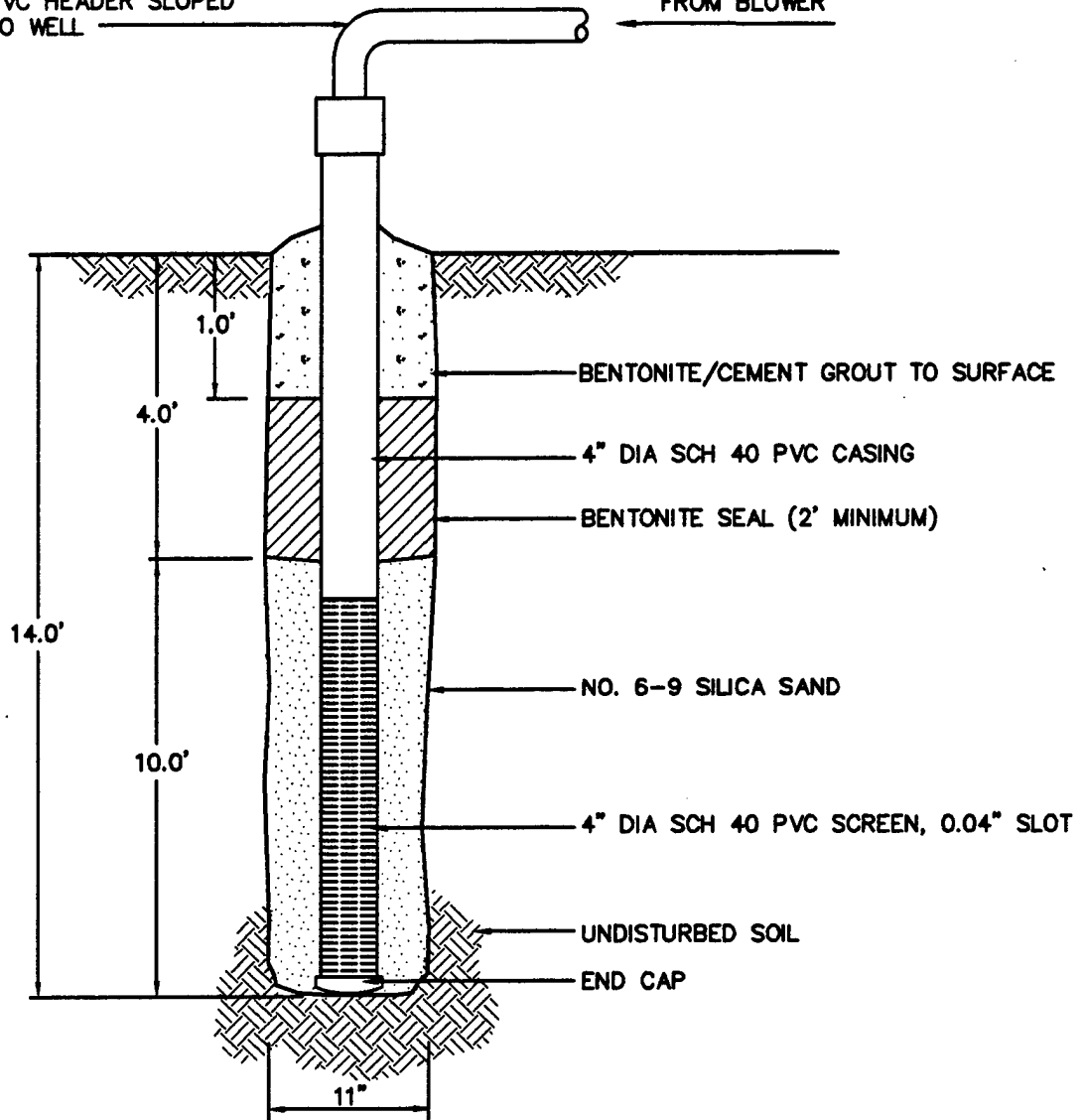

NOT TO SCALE

FIGURE 3.5

SITE SS-18
PROPOSED INJECTION VENT WELL
CONSTRUCTION DETAIL

LITTLE ROCK AFB, ARKANSAS

ENGINEERING-SCIENCE, INC.
Denver, Colorado

ES

A typical multi-depth vapor MP installation design for this site is shown in Figure 3.6. Soil gas oxygen and carbon dioxide concentrations will be monitored at depth intervals of 4 to 5 feet, and 7 to 8 feet at each location. If groundwater levels remain high, only the upper MPs will be used for initial testing. Multi-depth monitoring will confirm that the entire soil profile is receiving oxygen, and will be used to measure fuel biodegradation rates at each depth. The annular spaces between the two monitoring intervals in each MP will be sealed with bentonite to isolate the intervals. As in the central VW, several inches of bentonite pellets will be used to shield the filter pack from rapid infiltration of bentonite slurry additions. Thermocouples will be installed at both depths on MP1 to measure soil temperature. Additional details on VW and MP construction are provided in Section 4 of the protocol document. If auger refusal is encountered or contamination is extremely shallow, a horizontal trench system may be used.

3.3 Background Well

The construction of an additional vapor MP may be required to measure background levels of oxygen and carbon dioxide and to determine if natural carbon sources are contributing to oxygen uptake during the *in situ* respiration test described in Section 3.7. This background well would be installed in an area of uncontaminated soil and in the same stratigraphic formation as the VWs and MPs to be installed at Sites FT-01 and SS-18. The background well would be similar in construction to the MPs (Figures 3.3 and 3.6), and would be screened at 2 depths. ES will require some assistance from Little Rock AFB in selecting an appropriate location for the proposed background well.

Existing monitoring well, SU2, has been identified as a potential background well because it is partially screened above the water table (3-13 feet bgs) and located in an apparently uncontaminated area. If initial soil gas samples indicate that this well does not contain hydrocarbon contamination, and the samples contain oxygen in excess of 15 percent, this well may be selected as a background MP.

3.4 Handling of Drill Cuttings

Drill cuttings from all VW and MP borings will be collected in U.S. Department of Transportation (DOT) approved containers. The containers will be labeled and placed in the Little Rock AFB hazardous materials storage area. These drill cuttings will become the responsibility of Little Rock AFB, and will be analyzed, handled, and disposed of in accordance with the current procedures for ongoing remedial investigations. This project is expected to generate less than two 55-gallon drums of cuttings.

3.5 Soil and Soil Gas Sampling

3.5.1 Soil Samples

Three soil samples will be collected from each pilot test area during the installation of the VW and MPs. Sampling procedures will follow those outlined in the protocol document. One sample will be collected from the most contaminated interval of each VW boring, and one sample will be collected from the interval of highest apparent contamination in each of the borings for the two MPs closest to the

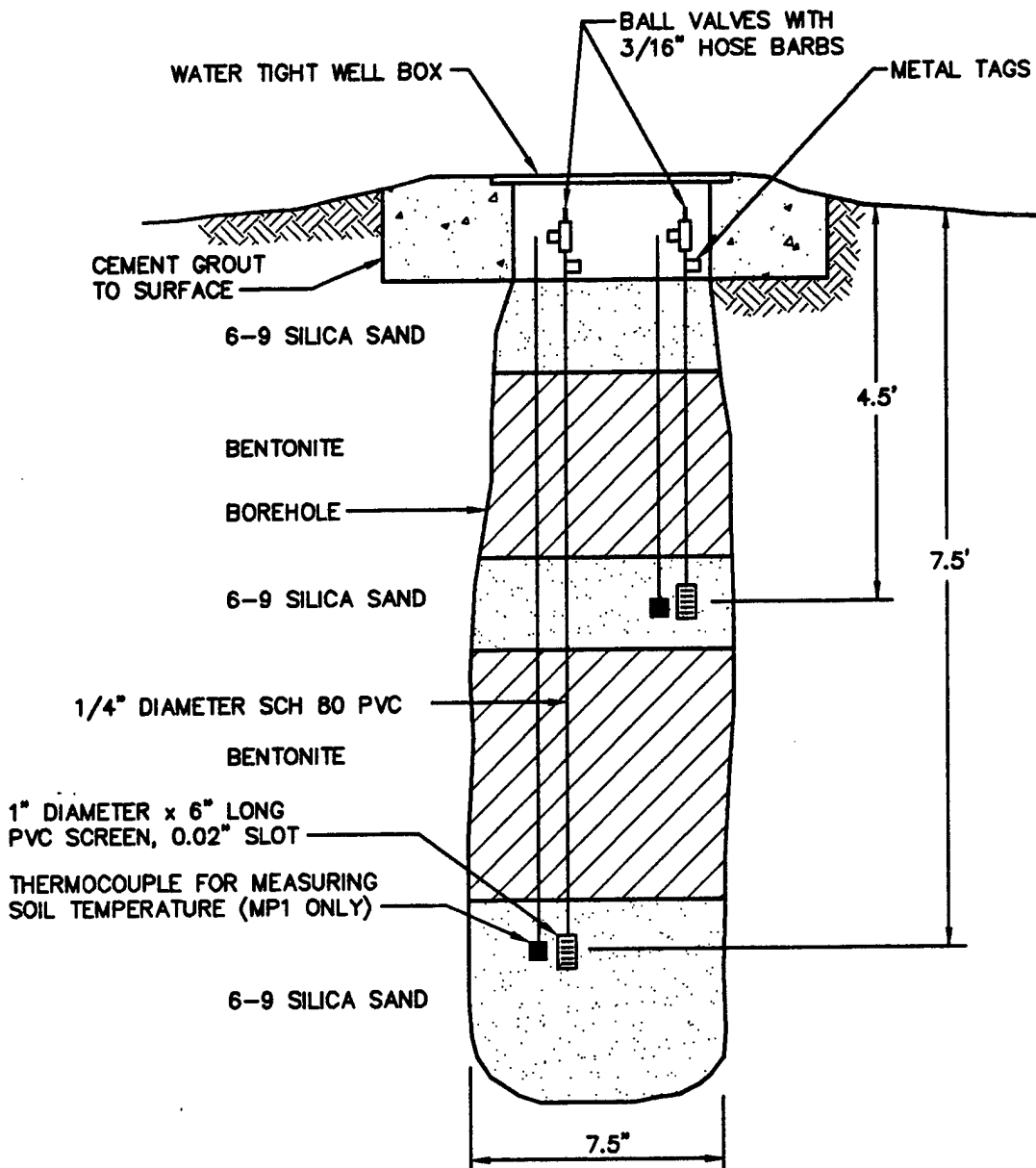

FIGURE 3.6

SITE SS-18
 PROPOSED MONITORING POINT
 CONSTRUCTION DETAIL

LITTLE ROCK AFB, ARKANSAS

ENGINEERING-SCIENCE, INC.
 Denver, Colorado



VW. Soil samples will be analyzed for TRPH, benzene, toluene, ethylbenzene, and xylenes (BTEX), soil moisture, pH, particle sizing, alkalinity, total iron, and nutrients. One sample will be collected from the background MP boring and analyzed for total Kjeldahl nitrogen (TKN).

Samples for TRPH and BTEX analysis will be collected using a split-spoon sampler containing brass tube liners. Soil samples collected in the brass tubes for TRPH and BTEX analyses will be immediately trimmed, and the ends will be sealed with aluminum foil or Teflon® fabric held in place by plastic caps. Soil samples collected for physical parameter analyses will be placed in glass sample jars or other appropriate sample containers specified in the base sample handling plan. Soil samples will be labelled following the nomenclature specified in the protocol document (Section 5), wrapped in plastic, and placed in a cooler for shipment. A chain-of-custody form will be filled out, and the cooler will be shipped to the ES laboratory in Berkeley, California, for analysis. This laboratory has been audited by the Air Force and meets all quality assurance/quality control and certification requirements for the State of California.

3.5.2 Soil Gas Samples

A total hydrocarbon vapor analyzer will be used during auguring to screen split-spoon soil samples for intervals of high fuel contamination. Initial and final soil gas samples will be collected in SUMMA® canisters, in accordance with the bioventing field sampling plan (Engineering-Science, Inc., 1992), from the VWs and from the MPs closest to and furthest from the VWs. Additionally, these soil gas samples will be used to predict potential air emissions, to determine the reduction in BTEX and TVH during the 1-year test, and to detect any migration of these vapors from the source area.

Soil gas sample canisters will be placed in a small cooler and packed with foam pellets to prevent excessive movement during shipment. Samples will not be sent on ice in order to prevent condensation of hydrocarbons. A chain-of-custody form will be filled out, and the cooler will be shipped to the Air Toxics, Inc. laboratory in Rancho Cordova, California for analysis.

3.6 Blower System

A 3-horsepower positive-displacement blower capable of injecting air at a flow rate of 20 to 40 standard cubic feet per minute (scfm) at a pressure of 8 pounds per square inch will be used to conduct the initial air permeability tests and *in situ* respiration tests. Figure 3.7 is a schematic of a typical air injection system used for pilot testing. The maximum power requirement anticipated for this pilot test is 230-volt, single-phase, 30-amp service. Additional details on power supply requirements are described in Section 5.0, Base Support Requirements.

3.7 In Situ Respiration Tests

The objective of the *in situ* respiration tests is to determine the rate at which soil bacteria degrade petroleum hydrocarbons. Respiration tests will be performed at every vapor MP where bacterial biodegradation of hydrocarbons is indicated by low oxygen levels and elevated carbon dioxide concentrations in the soil gas. Using a

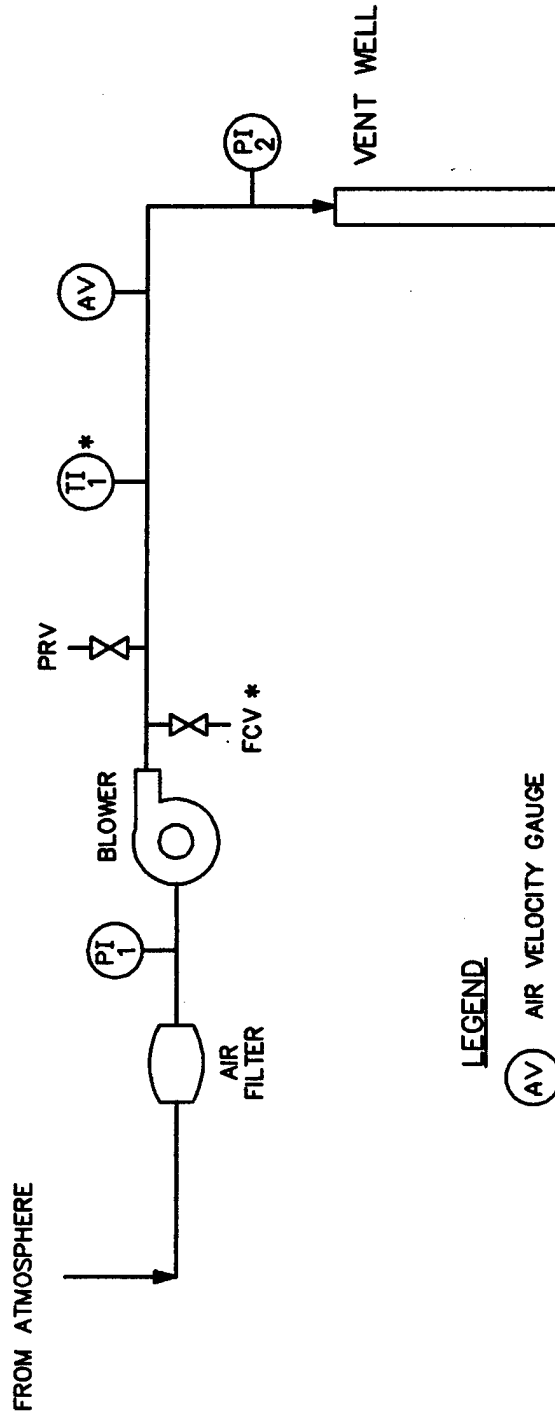

LEGEND

- (AV) AIR VELOCITY GAUGE
- (PI₁) PRESSURE INDICATOR
- (TI₁) TEMPERATURE INDICATOR
- FCV FLOW CONTROL VALVE
- PRV PRESSURE RELIEF VALVE
- * OPTIONAL

FIGURE 3.7

**BLOWER SYSTEM
INSTRUMENTATION DIAGRAM
FOR AIR INJECTION**

LITTLE ROCK AFB, ARKANSAS

ENGINEERING-SCIENCE, INC.
Denver, Colorado

ES

1-scfm pump, air will be injected into each MP depth interval containing low levels (<2%) of oxygen. A 20-hour air injection period will be used to oxygenate local contaminated soils. At the end of the 20-hour air injection period, the air supply will be cut off, and oxygen and carbon dioxide levels will be monitored for the following 48 to 72 hours. The decline in oxygen and increase in carbon dioxide concentrations over time will be used to estimate rates of bacterial degradation of fuel residuals. Helium will also be injected at one or two MPs to determine whether there are leaks in the monitoring points, allowing oxygen to escape. Additional details on the *in situ* respiration test procedures are provided in Section 5.7 of the protocol document (Hinchee et al., 1992).

3.8 Air Permeability Tests

The objective of the air permeability tests is to determine the extent of the subsurface that can be oxygenated using the VW. Air will be injected into the 4-inch-diameter VW using the blower unit, and pressure response will be measured at each MP with differential pressure gauges to determine the region influenced by the unit. Oxygen will also be monitored in the MPs to ascertain whether oxygen levels in the soil increase as the result of air injection. One air permeability test lasting 4 to 8 hours will be performed at each site.

3.9 Potential for Air Emissions

The potential for air emissions is considered low for these sites. Little or no free product remains at these sites, and due to the age of the spills, BTEX concentrations in soil gas are generally less than 1 part per million, volume per volume (ppmv). During initial air injection, health and safety monitoring will ensure that breathing zone hydrocarbon concentrations do not exceed 1 ppmv. Due to the tight soil conditions, low injection rates, and low BTEX levels in the soil, the potential for measurable emissions is very low.

3.10 Extended Pilot Test Bioventing System

If initial testing shows adequate soil permeability and oxygen transport, extended bioventing systems will also be installed at Site FT-01 and Site SS-18. At each site, the base will be requested to provide a power pole with a 230-volt, single-phase, 30-amp breaker box, one 230-volt receptacle, and two 115-volt receptacles. Depending on the availability of a base electrician, a base electrician or a licensed electrician subcontracted to ES will assist in wiring the blowers to line power. The blowers will be 1.5-hp, rotary-vane blowers capable of injecting air at 5 pounds per square inch (psi) and 14 cfm. The blowers will be provided with vacuum, pressure, and temperature gauges, and air filters, pressure relief, and flow control valves (see Figure 3.7). The blowers will be housed in small, prefabricated sheds to provide protection from the weather.

The systems will be in operation for 1 year, and every 6 months ES personnel will conduct *in situ* respiration tests to monitor the long-term performance of this bioventing system. Weekly system checks will be performed by Little Rock AFB personnel. If required, major maintenance of the blower unit may be performed by ES personnel. Detailed blower system information and a maintenance schedule will

be included in the operation and maintenance (O&M) manual provided to the base. More detailed information regarding the test procedures can be found in the protocol document.

4.0 EXCEPTIONS TO PROTOCOL PROCEDURES

The procedures that will be used to measure the air permeability of the soil and *in situ* respiration rates are described in Sections 4 and 5 of the protocol document (Hinchee et al., 1992). No exceptions to the protocol procedures are anticipated.

5.0 BASE SUPPORT REQUIREMENTS

The following base support is needed prior to the arrival of the drilling subcontractor and the ES pilot test team:

- Assistance in obtaining drilling and digging permits.
- Assistance in selecting a suitable location for the background well. The background well location should be in an area with no fuel contamination and with similar stratigraphy to that of Site FT-01 and Site SS-18. Preferably, 110-volt receptacle power will be available within 150 feet of the background well location.
- Installation of power poles at Site FT-01 and Site SS-18. Each pole should include a 230-volt, 30-amp, single-phase service and a breaker box with one 230-volt receptacle and two 115-volt receptacles. The poles should be located within 10 feet of the proposed central VW location at each site.
- Provision of any paperwork required to obtain gate passes and security badges for approximately three ES employees, two drillers, and an electrician (if a base electrician is not available). Vehicle passes will be needed for one truck and a drill rig.

During the initial testing, the following base support is needed:

- A decontamination area where the driller can clean augers between borings.
- Acceptance of responsibility by Little Rock AFB for drill cuttings from VW and MP borings, including any drum sampling to determine hazardous waste status.
- Twelve square feet of desk space and a telephone in a building located as close to the site as practicable.
- The use of a facsimile machine for transmitting 15 to 20 pages of test results.

During the 1-year extended pilot test, base personnel will be required to perform the following activities:

- Check the blower system once per week to ensure that it is operating and to record the air injection pressure and temperature. Change air filters when required. ES will provide a brief training session on these procedures and an O&M manual.

- If the blower stops working, notify Ms. Gail Saxton or Mr. Doug Downey, ES-Denver, at (303) 831-8100, or Mr. Sam Taffinder, AFCEE, at (210) 536-4366.
- Arrange site access for an ES technician to conduct *in situ* respiration tests approximately 6 months and 1 year after the initial pilot test.

6.0 PROJECT SCHEDULE

The following schedule is contingent upon timely approval of this pilot test work plan.

<u>Event</u>	<u>Date</u>
Draft Test Work Plan to AFCEE/Little Rock AFB	26 April 1993
Notice to Proceed	7 May 1993
Begin Initial Pilot Tests	19 July 1993
Complete Initial Pilot Tests	30 July 1993
Interim Results Report	29 October 1993
Second Respiration Tests	March 1994
Final Respiration Tests	September 1994

7.0 POINTS OF CONTACT

Bill Hood
314 CES/CEV
4001 Thomas Ave.
Jacksonville, AR 72099-5005
(501) 988-6762

Sam Taffinder
AFCEE/EST
2504 D Drive, Suite 3
Brooks AFB, TX 78235-5103
(210) 536-4366

Mr. Doug Downey
Engineering-Science, Inc.
1700 Broadway, Suite 900
Denver, CO. 80290
(303) 831-8100
Fax (303) 831-8208

8.0 REFERENCES

- CDM Federal Programs Corporation. 1992. *Site Investigation Report, POL Sites*. March. Lenexa, KS.
- CDM Federal Programs Corporation. 1993. *Remedial Investigation/Feasibility Study, Site FT-01*. January. Lenexa, KS.

Engineering-Science, Inc. 1992. *Field Sampling Plan for AFCEE Bioventing*. April.
Denver, CO

Hinchee, R.E., S.K. Ong, R.N. Miller, D.C. Downey, and R. Frandt. 1992. *Test Plan
and Technical Protocol for a Field Treatability Test for Bioventing*. January.

PART II
DRAFT INTERIM PILOT TEST RESULTS REPORT FOR
SITE FT-01 AND SITE SS-18
LITTLE ROCK AFB, ARKANSAS

Prepared for:

Air Force Center for Environmental Excellence
Brooks AFB, Texas

and

Little Rock AFB, Arkansas

Prepared by:

Engineering-Science, Inc.
1700 Broadway, Suite 900
Denver, Colorado 80290

October 1993

**DRAFT INTERIM PILOT TEST RESULTS REPORT FOR
SITE FT-01 AND SITE SS-18
LITTLE ROCK AFB, ARKANSAS**

Prepared for:

**Air Force Center for Environmental Excellence
Brooks AFB, Texas**

and

Little Rock AFB, Arkansas

Prepared by:

**Engineering-Science, Inc.
1700 Broadway, Suite 900
Denver, Colorado 80209**

October 1993

CONTENTS

PART II - DRAFT INTERIM PILOT TEST RESULTS REPORT FOR FT-01 AND SS-18 LITTLE ROCK AFB, ARKANSAS

	<u>Page</u>
1.0 Pilot Test Design and Construction	II-1
1.1 Site FT-01, Fire Training Area.....	II-1
1.1.1 Monitoring Point	II-4
1.2 Site SS-18, Spill Site 18	II-4
1.2.1 Air Injection Vent Well.....	II-4
1.2.2 Monitoring Points	II-4
1.2.3 Blower Unit	II-11
2.0 Pilot Test Soil and Soil Gas Sampling Results	II-11
2.1 Site FT-01, Fire Training Area.....	II-11
2.1.1 Sampling Results	II-11
2.1.2 Exceptions to Test Protocol Document Procedures.....	II-13
2.2 Site SS-18, Spill Site 18	II-13
2.2.1 Sampling Results	II-13
2.2.2 Exceptions to Test Protocol Document Procedures.....	II-15
3.0 Pilot Test Results	II-15
3.1 Site FT-01, Fire Training Area.....	II-15
3.2 Site SS-18, Spill Site 18	II-15
3.2.1 Initial Soil Gas Chemistry.....	II-15
3.2.2 Air Permeability	II-17
3.2.3 Oxygen Influence.....	II-17
3.2.4 <i>In Situ</i> Respiration Rates	II-17
3.2.5 Potential Air Emissions.....	II-26
4.0 Recommendations	II-26
4.1 Site FT-01, Fire Training Area.....	II-26
4.2 Site SS-18, Spill Site 18	II-26
5.0 References	II-27

Appendix A - Geologic Boring Logs, Chain-of-Custody Forms, Test Data, and Calculations

Appendix B - O&M Checklist

TABLES

<u>No.</u>	<u>Title</u>	<u>Page</u>
2.1	Soil Analytical Results, Site FT-01	II-14

TABLES

<u>No.</u>	<u>Title</u>	<u>Page</u>
2.2	Soil and Soil Gas Analytical Results, Site SS-18	II-16
3.1	Initial Soil Gas Chemistry, Site SS-18	II-18
3.2	Maximum Pressure Response, Air Permeability Test, Site SS-18	II-19
3.3	Influence of Air Injection at Vent Well on Monitoring Point Oxygen Levels, Site SS-18.....	II-20
3.4	Oxygen Utilization Rates, Site SS-18.....	II-25

FIGURES

<u>No.</u>	<u>Title</u>	<u>Page</u>
1.1	As-Built Boring and Monitoring Point Locations, Site FT-01	II-2
1.2	Hydrogeologic Cross Section, Site FT-01	II-3
1.3	As-Built Monitoring Point Construction Detail, Site FT-01	II-5
1.4	As-Built Exploratory Boring Locations, Site SS-18	II-6
1.5	As-Built Vent Well and Monitoring Point Locations, Site SS-18	II-7
1.6	Hydrogeologic Cross Section, Site SS-18.....	II-8
1.7	As-Built Injection Vent Well Construction Detail, Site SS-18.....	II-9
1.8	Typical As-Built Monitoring Point Construction Detail, Site SS-18	II-10
1.9	As-Built Extended Pilot Test Blower System for Air Injection, Site SS-18..	II-12
3.1	Respiration Test: Vent Well, Site SS-18	II-21
3.2	Respiration Test: Monitoring Point MPA-6.5, Site SS-18	II-22
3.3	Respiration Test: Monitoring Point MPB-4.5, Site SS-18.....	II-23
3.4	Respiration Test: Monitoring Point MPA-3.5, Site SS-18	II-24

PART II
DRAFT
INTERIM PILOT TEST RESULTS REPORT
FOR SITE FT-01 AND SITE SS-18
LITTLE ROCK AIR FORCE BASE, ARKANSAS

Initial bioventing pilot tests were completed by Engineering-Science, Inc. (ES) at Fire Training Site 1 (FT-01) and Spill Site 18 (SS-18) at Little Rock Air Force Base (AFB), Arkansas during the period of July 19 through 29, 1993. The purpose of this report is to describe the results of the initial pilot tests at FT-01 and SS-18 and to make specific recommendations for extended testing to determine the long-term impact of bioventing on site contaminants. Descriptions of the history, geology, and contamination at FT-01 and SS-18 are contained in Part I, the Bioventing Pilot Test Work Plan.

1.0 PILOT TEST DESIGN AND CONSTRUCTION

Installation of an air injection vent well (VW) and four vapor monitoring points (MPs) at SS-18 took place on July 22 and 23, 1993. Shallow groundwater prevented the installation of an air injection well at FT-01. One MP was installed at this site to determine if soil gas could be extracted from these wet soils. Drilling services were provided by Professional Service Industries, Inc. (PSI) of Oklahoma City, Oklahoma, and well installation and soil sampling was directed by Mr. Rusty Frishmuth, the ES site manager. The following sections describe the final design and installation of the bioventing systems at each site.

1.1 Site FT-01, Fire Training Area

Groundwater was encountered at approximately 4 feet at FT-01. Such shallow groundwater prevented the installation of an air injection bioventing system at the site. Shallow groundwater also precluded the possibility of constructing a horizontal injection system in a trench. One MP was installed at 4 feet to allow future monitoring of soil gas should the water level decline. Figures 1.1 and 1.2, respectively, depict the locations of and hydrogeologic cross section for the soil borings and the MP completed in the area. The borings that were not completed were abandoned by backfilling to the surface with bentonite chips. Analytical samples were taken from the site and analyzed in accordance with the work plan. Boring logs for the exploratory borings and MP borehole are included in Appendix A.

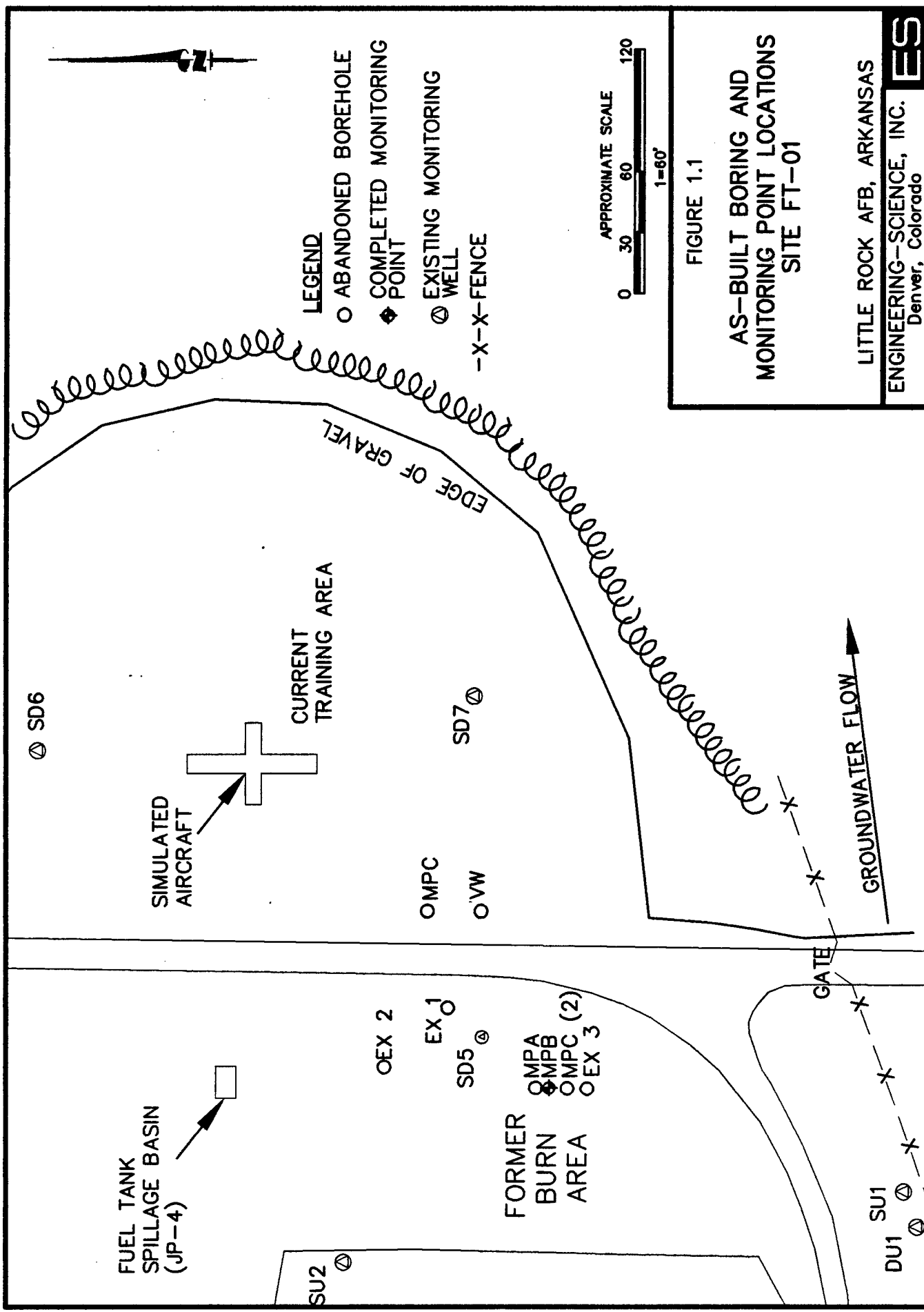

93DN0399, 08/17/93 at 10:30

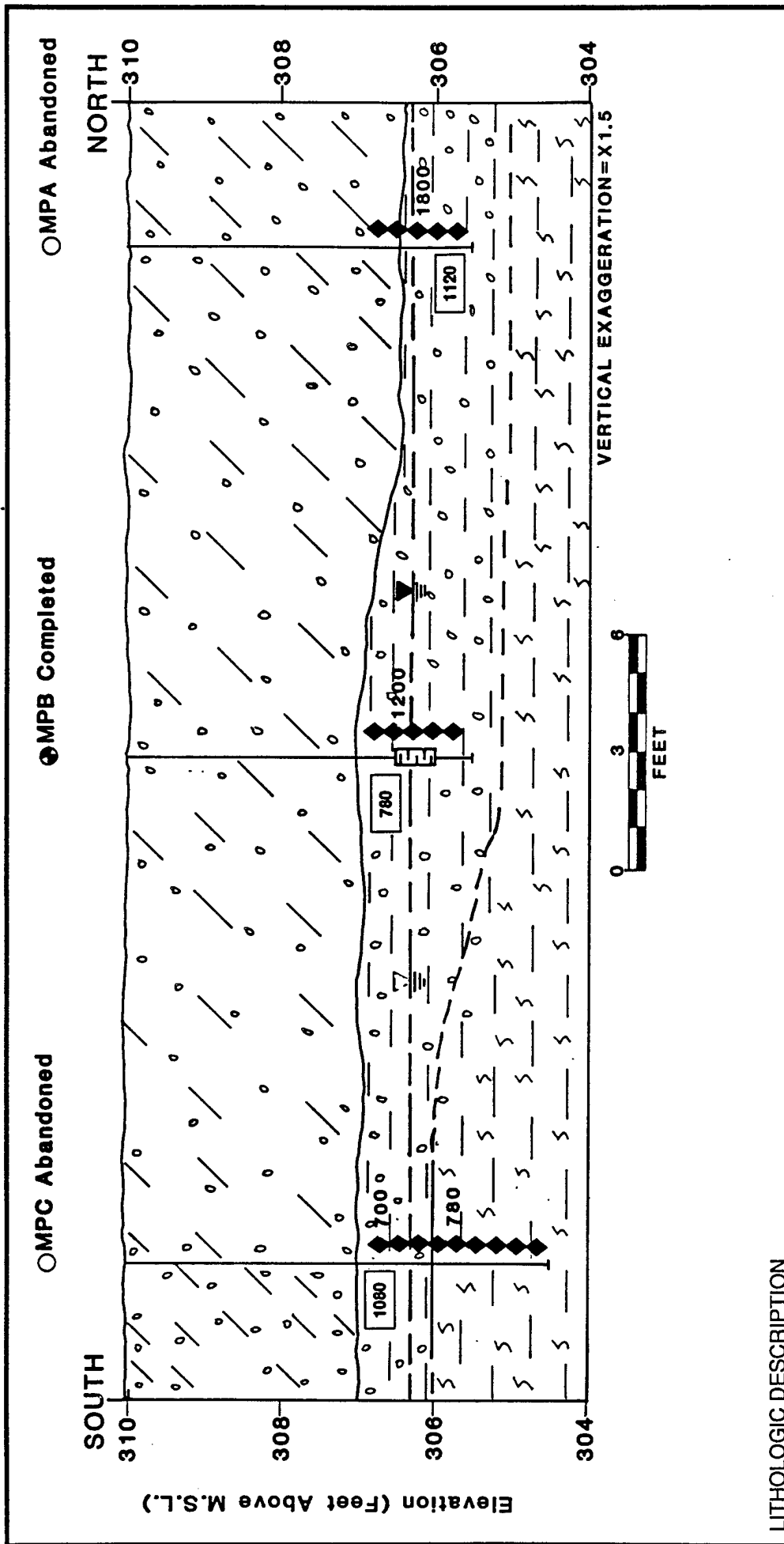

FIGURE 1.2

HYDROGEOLOGIC CROSS SECTION Site FT-01

LITTLE ROCK AFB, ARKANSAS

ENGINEERING-SCIENCE, INC.
Denver, Colorado

ES

LITHOLOGIC DESCRIPTION	
	SILTY CLAY
	GRAVELLY CLAY
	GRAVELLY LOAM

LEGEND	
	MONITORING POINT
	INJECTION VENT WELL
	FIELD SCREENING RESULTS FOR TOTAL VOLATILE HYDROCARBONS (ppmv)
	LABORATORY RESULTS FOR SOIL TOTAL PETROLEUM HYDROCARBONS (mg/kg)
	STATIC GROUNDWATER ELEVATION
	GEOLOGIC CONTACT, DASHED WHERE INFERRED
	MONITORING POINT SCREENED INTERVAL
	FUEL ODOR DETECTED DURING DRILLING

1.1.1 Monitoring Point

The MP screened interval was installed at a depth of 4 feet below ground surface (bgs). The MP at this site was constructed as shown in Figure 1.3. It was constructed using a 6-inch section of 1-inch-diameter polyvinyl chloride (PVC) well screen with a 0.25-inch PVC riser pipe extending to the ground surface. At the top of the riser, a ball valve and a 3/16-inch hose barb were installed. The top of the MP was completed with a flush-mounted metal well protector set in concrete. A thermocouple was not installed at this MP. Attempts to sample soil gas from this MP indicate that it is flooded with groundwater and is not currently suitable for sampling. The point will be monitored during subsequent site visits to determine if groundwater levels have receded enough to allow soil gas sampling.

1.2 Site SS-18, Spill Site 18

One VW, four MPs, and a blower unit were installed at SS-18. Figures 1.4, 1.5, and 1.6, respectively, depict the locations of and hydrogeologic cross section for the VW and MPs completed at the site. Also shown in Figure 1.4 are the locations of several exploratory borings installed at SS-18. These borings were used to locate an area of elevated hydrocarbon concentration in which to install the injection system. Exploratory borings were abandoned by backfilling to the surface with bentonite chips. Boring logs for the MPs and VW are included in Appendix A. The background MP for this site was installed approximately 170 feet north-northwest of the VW (Figure 1.4).

1.2.1 Air Injection Vent Well

The air injection VW was installed following procedures described in the Air Force Center for Environmental Excellence (AFCEE) bioventing protocol document (Hinchee et al., 1992). Figure 1.7 shows construction details for the VW. The VW was installed in contaminated soils with the screened interval extending from 3 to 10 feet bgs. The groundwater surface at this site was approximately 8 feet bgs during the pilot test. It is believed that 5 feet of screen above groundwater will be adequate to sufficiently oxygenate the soils at the site. The VW was constructed using 4-inch-diameter, Schedule 40 PVC casing, with 7 feet of 0.04-inch slotted PVC screen. The annular space between the well casing and borehole was filled with 8-12 silica sand from the bottom of the borehole to approximately 1 foot above the well screen. Two feet of granular bentonite was placed above the sand and hydrated in place. The top of the well was completed with a 4-inch-diameter PVC tee with a screw cap.

1.2.2 Monitoring Points

MP screens were installed at 4.5- and 7.5-foot depths at MPB. MP screens at MPA and MPC were installed at 3.5- and 6.5-foot depths after it was discovered that the 7.5-foot depth at MPB had become flooded with groundwater. The three MPs at this site were constructed as shown in Figure 1.8 with the exception of MPB which was constructed with screened intervals 1 foot deeper than the other two points. Each was constructed using 6-inch sections of 1-inch-diameter PVC well screen and 0.25-inch Schedule 80 PVC riser pipes extending to the ground surface. At the top of each riser,

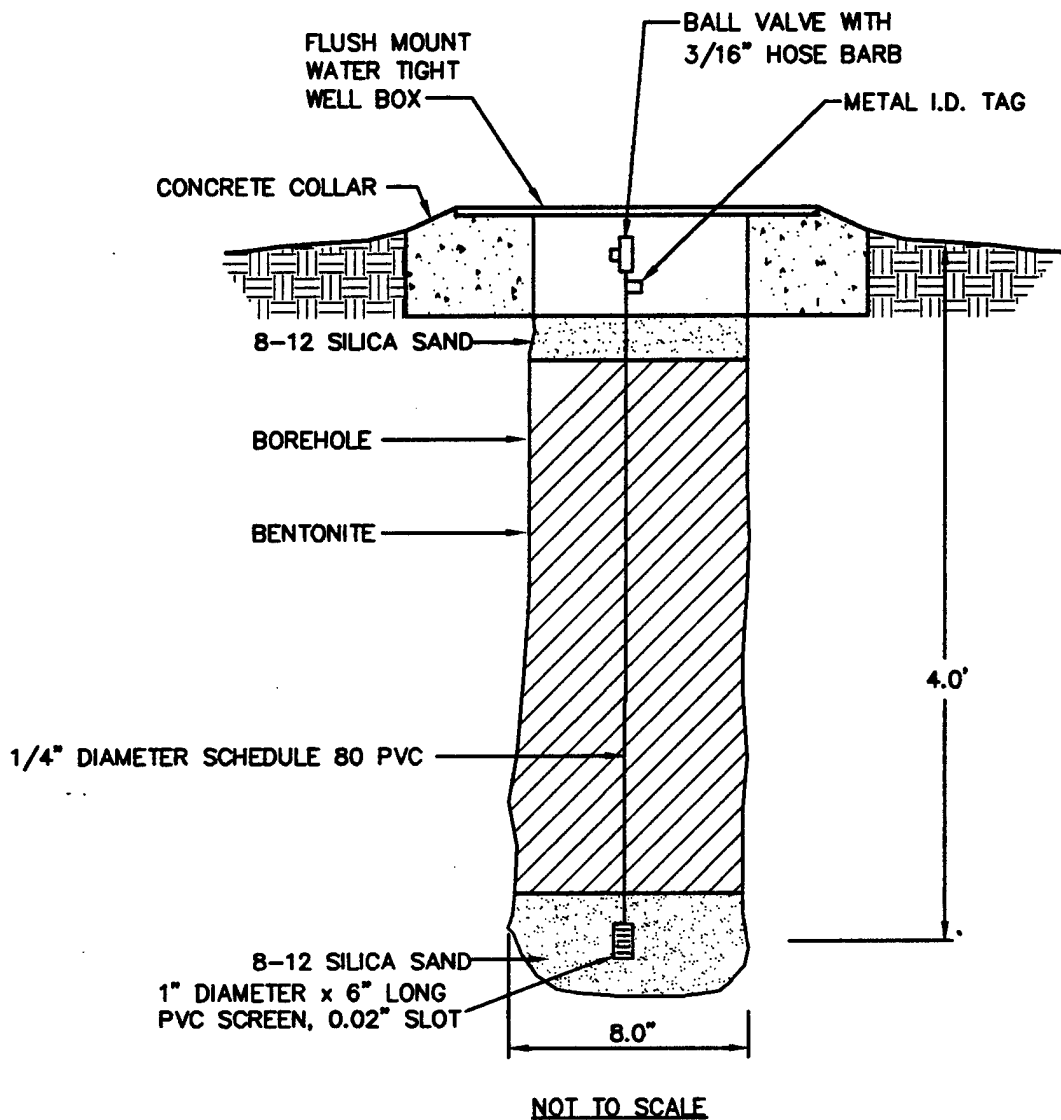
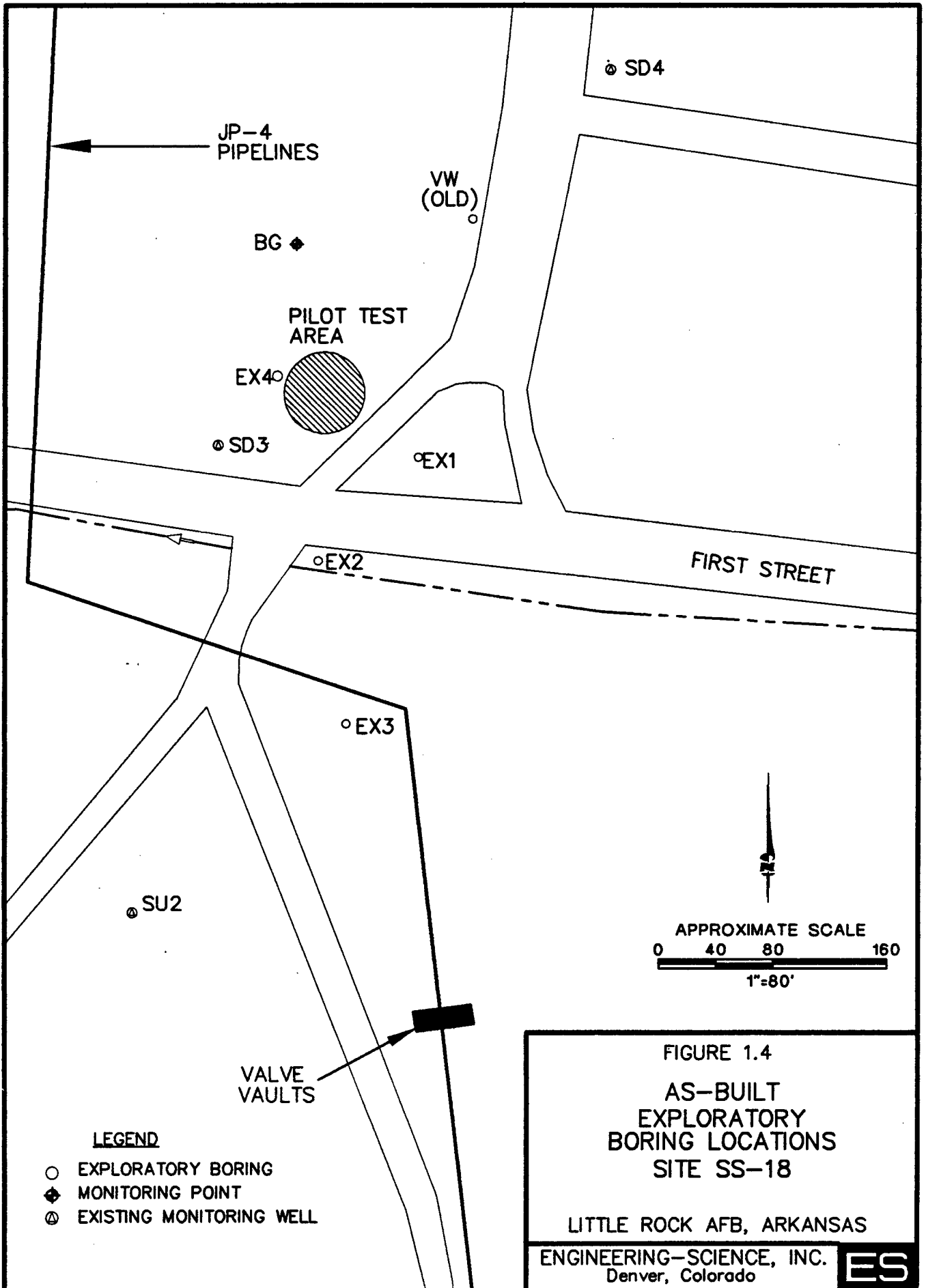
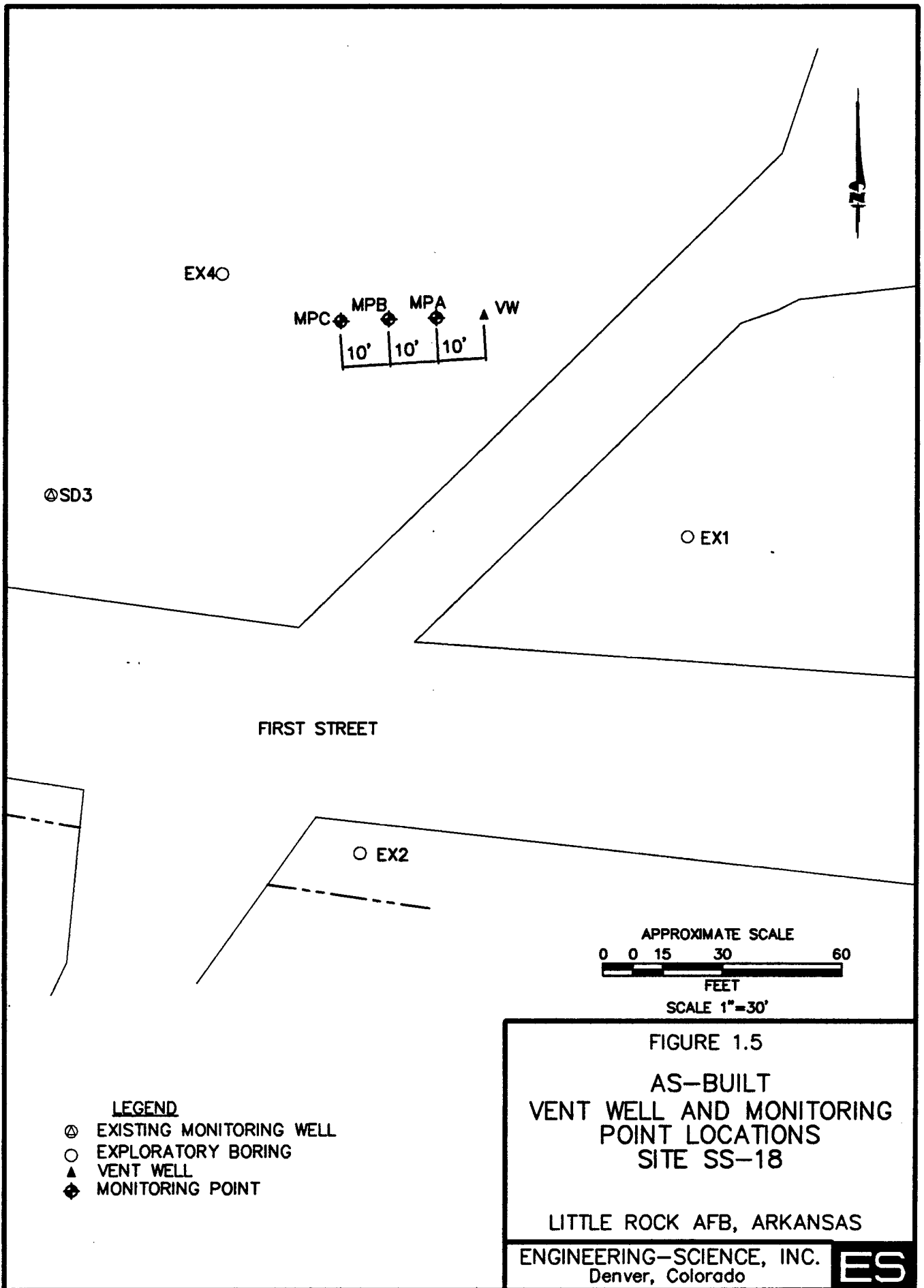

FIGURE 1.3
 AS-BUILT
 MONITORING POINT
 CONSTRUCTION DETAIL
 SITE FT-01

LITTLE ROCK AFB, ARKANSAS
 ENGINEERING-SCIENCE, INC.
 Denver, Colorado







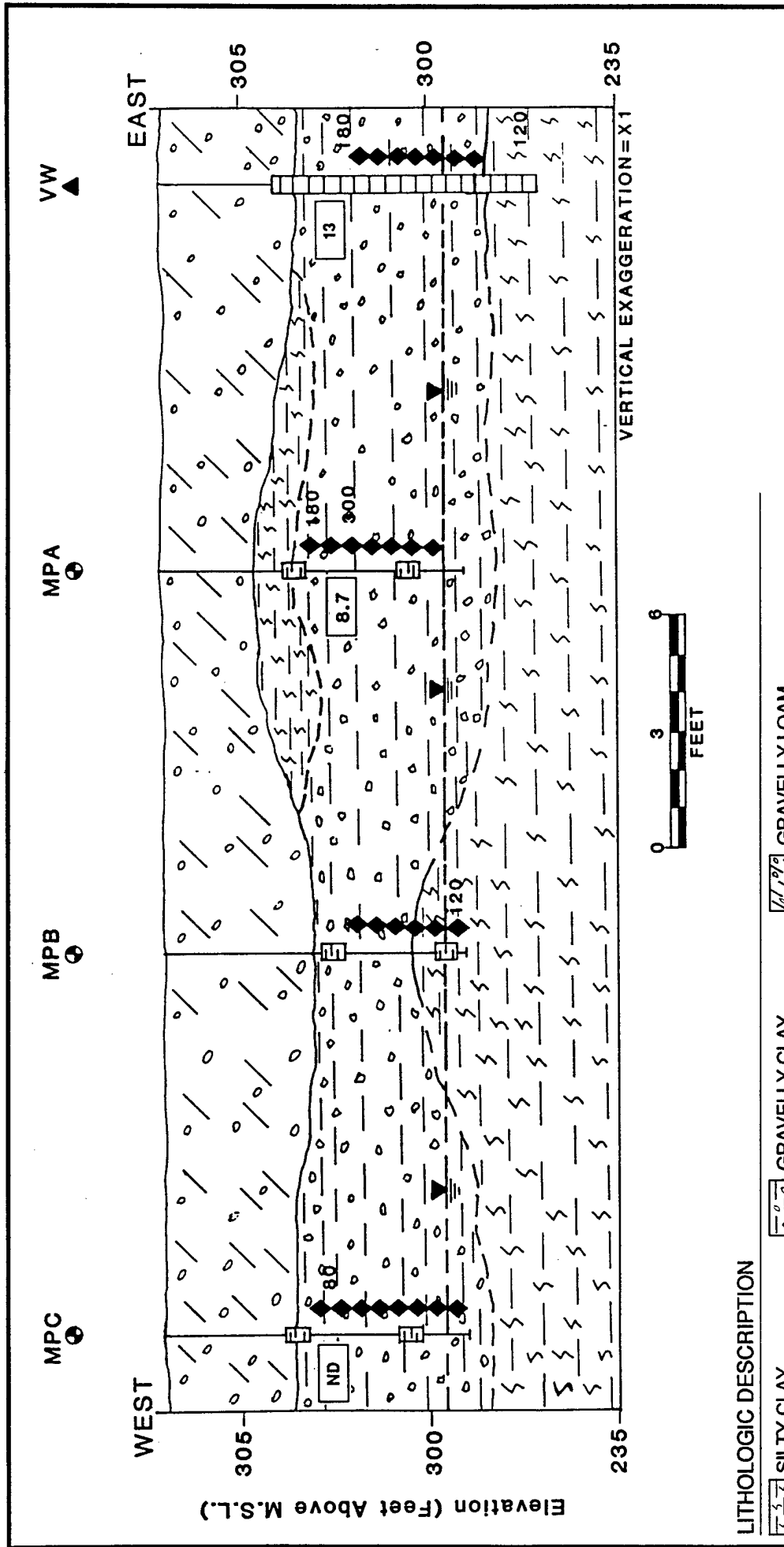

FIGURE 1.6

**HYDROGEOLOGIC
CROSS SECTION
Site SS-18**

LITTLE ROCK AFB, ARKANSAS













ENGINEERING-SCIENCE, INC.
Denver, Colorado

ES

LITHOLOGIC DESCRIPTION

-  SILTY CLAY
-  GRAVELLY CLAY
-  GRAVELLY LOAM

LEGEND

-  MPC ● MONITORING POINT (ENSR SOIL BORING)
-  MPB ● MONITORING POINT (ENSR SOIL BORING)
-  MPA ● MONITORING POINT (ENSR SOIL BORING)
-  VW ▲ VENT WELL (ENSR SOIL BORING)
-  80 ● FIELD SCREENING RESULTS FOR TOTAL VOLATILE HYDROCARBONS (ppmv)
-  8.7 ● LABORATORY RESULTS FOR SOIL TOTAL PETROLEUM HYDROCARBONS (mg/kg)
-  ◆ FUEL ODOR DETECTED DURING DRILLING
-  --- STATIC GROUNDWATER ELEVATION
-  --- GEOLOGIC CONTACT, DASHED WHERE INFERRED
-  □ MONITORING POINT
-  ▭ SCREENED WELL INTERVAL
-  ND NOT DETECTED

2" DIAMETER SCH 40
PVC HEADER SLOPED
TO WELL

FROM BLOWER

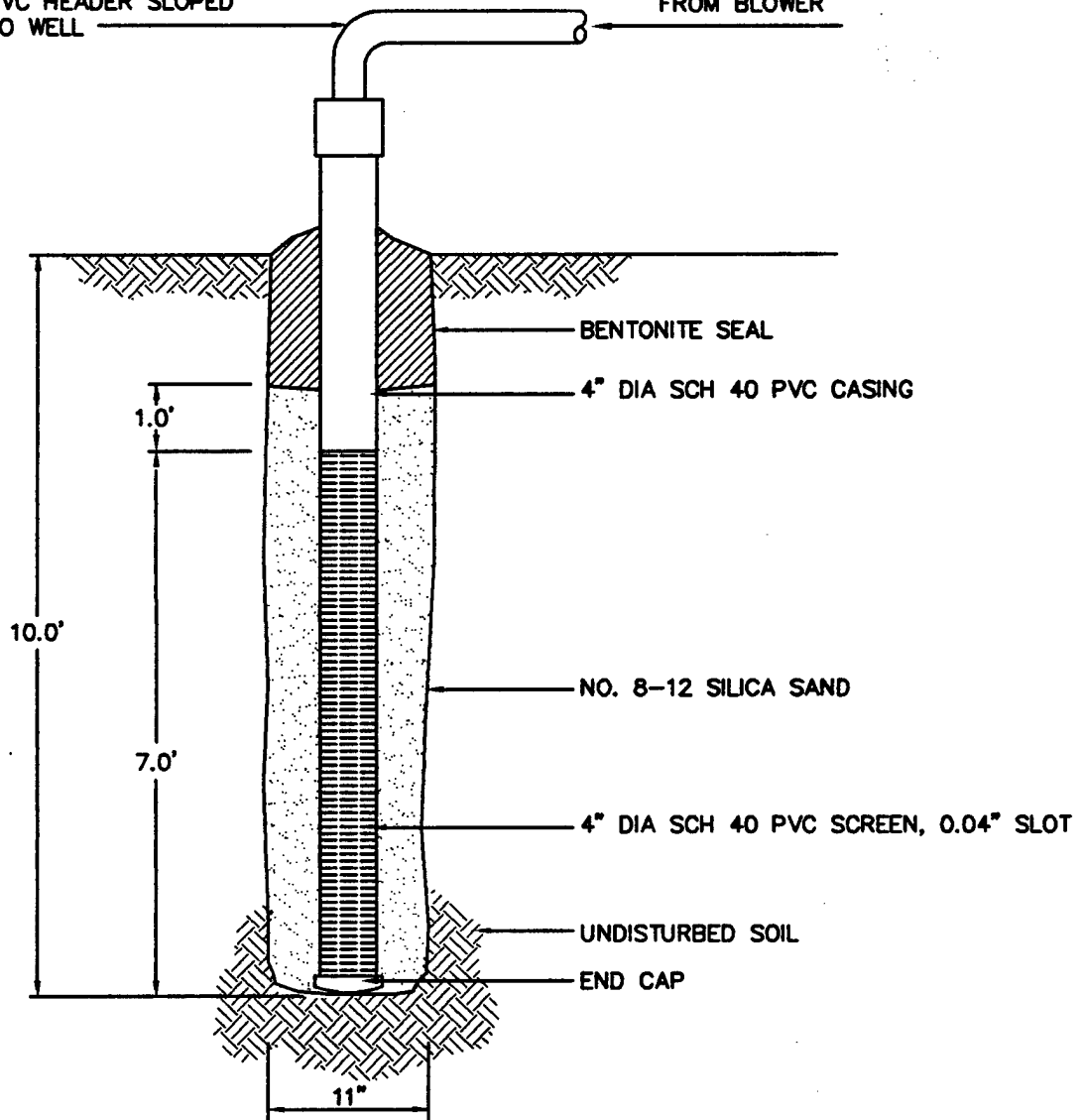

NOT TO SCALE

FIGURE 1.7

AS-BUILT INJECTION
VENT WELL
CONSTRUCTION DETAIL
SITE SS-18

LITTLE ROCK AFB, ARKANSAS

ENGINEERING-SCIENCE, INC.
Denver, Colorado

ES

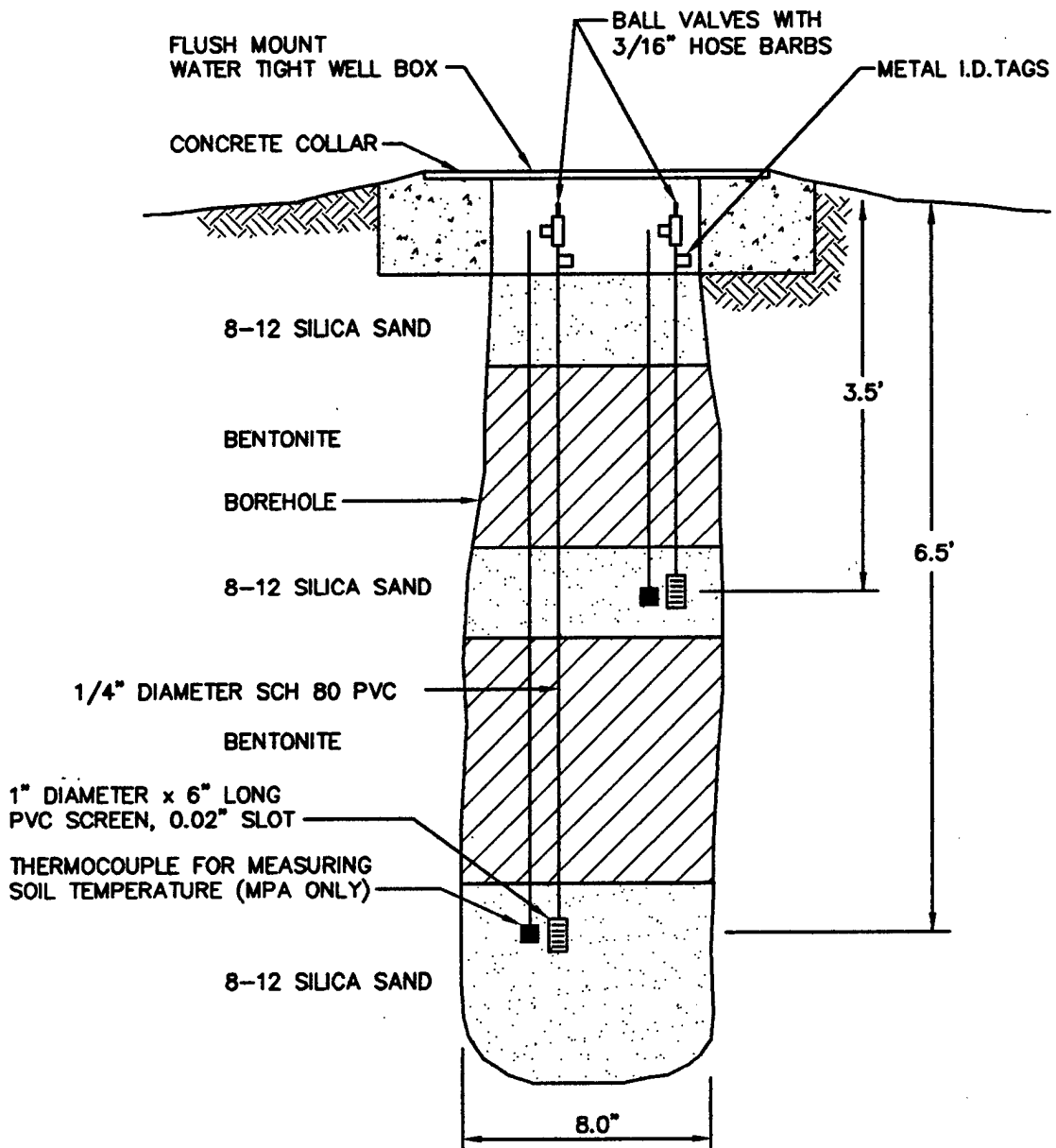

NOT TO SCALE

FIGURE 1.8

TYPICAL AS-BUILT
MONITORING POINT
CONSTRUCTION DETAIL
SITE SS-18

LITTLE ROCK AFB, ARKANSAS

ENGINEERING-SCIENCE, INC.
Denver, Colorado

ES

a ball valve and a 3/16-inch hose barb were installed. The top of each MP was completed with a flush-mounted metal well protector set in concrete. Thermocouples were installed at the 3.5- and 6.5-foot depths at MPA to measure soil temperature variations.

1.2.3 Blower Unit

A 3-horsepower Roots® positive displacement blower unit was used at site SS-18 for the initial pilot test, and a 1 horsepower Gast® regenerative blower unit was installed for the extended pilot test. For the initial pilot test, the blower was energized by 208-volt, single-phase, 30-amp power from a generator supplied by the Civil Engineering Squadron (CES) at Little Rock AFB. The extended pilot test unit will be energized by 208-volt, single-phase power supplied to the site by the Little Rock AFB CES. Power will be wired from an existing aboveground line approximately 500 feet to the north of the site. Once power is supplied, the blower will be configured to inject approximately 10 standard cubic feet per minute (scfm) for the extended pilot test. The configuration, instrumentation, and specifications for the extended pilot test unit are shown on Figure 1.9. Prior to departing from the site, ES engineers provided an operations and maintenance (O&M) briefing, checklist, and blower maintenance manual to plant personnel. A copy of the checklist is provided in Appendix B.

2.0 PILOT TEST SOIL AND SOIL GAS SAMPLING RESULTS

2.1 Site FT-01, Fire Training Area

2.1.1 Sampling Results

Soils at this site consist of gravelly silt and clay overlying shale bedrock (Figure 1.2). The bedrock was not encountered during drilling for this pilot test and is not shown on the figure. The general soil profile consists of gravelly loam in the upper 3 to 4 feet, gravelly clay from approximately 3 to 5 feet bgs, and silty clay below approximately 5 feet. Groundwater was encountered at 4 to 6 feet bgs in all borings at the site. The entire site is covered with approximately 3 inches of gravel. Logs for borings at the site are included in Appendix A.

Hydrocarbon contamination at this site appears to be confined to the gravelly clay layer. It is also believed that this layer is the source of the shallow groundwater found in the area. Contaminated soils were identified based on odor and volatile organic compound (VOC) field screening results. Contaminated soils were encountered in all three boreholes at FT-01 with the greatest contamination occurring in MPA. Soils in all three boreholes had a noticeable hydrocarbon odor.

Soil samples for laboratory analysis were collected from split- spoon samplers and placed in 4-ounce glass sample jars with Teflon seals. Soil samples were screened for VOCs using a photoionization detector (PID) to determine the presence of contamination and to select soil samples for laboratory analysis. Soil samples for laboratory analysis were collected from a depth of 3.5 feet from MPB and MPC, and from a depth of 4 feet from MPA. One additional soil sample was collected for drill cutting waste characterization. Soil gas samples could not be collected from this site due to shallow groundwater.

LEGEND

- ① INLET AIR FILTER - SOLBERG® F-18P-150
- ② VACUUM GAUGE (in H₂O)
- ③ 1-HP BLOWER - GAST® R4110N-50
- ④ MANUAL PRESSURE RELIEF (BLEED) VALVE
- ⑤ AUTOMATIC PRESSURE RELIEF VALVE
- ⑥ PRESSURE GAGE (in H₂O)
- ⑦ TEMPERATURE GAGE (°F)
- ⑧ BREAKER BOX - 208V/SINGLE PHASE/30 AMP TO BE INSTALLED BY LITTLE ROCK AFB PERSONNEL

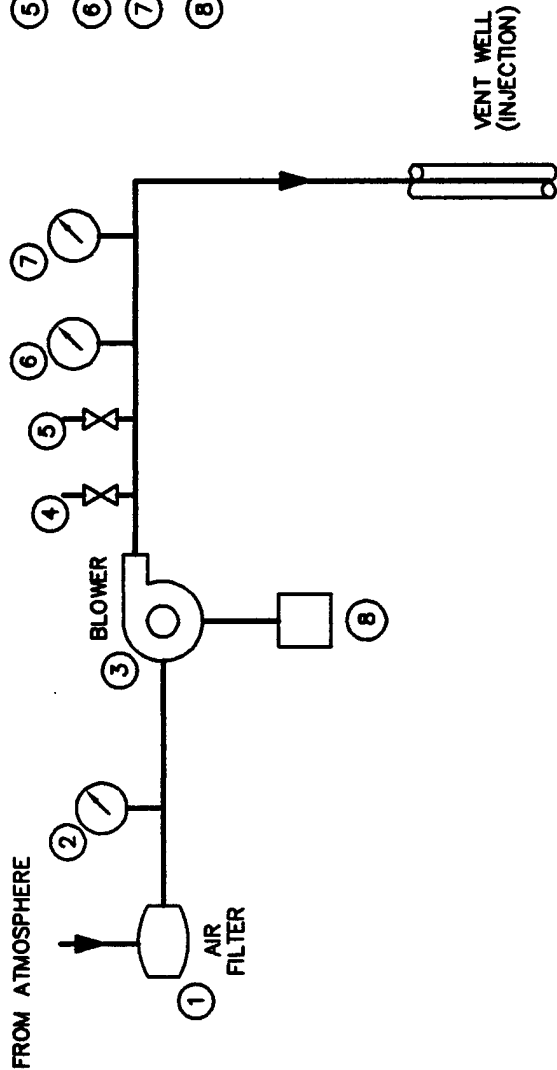

FIGURE 1.9

AS- BUILT
 EXTENDED PILOT TEST BLOWER
 SYSTEM FOR AIR INJECTION
 SITE SS-18

LITTLE ROCK AFB, ARKANSAS

ENGINEERING-SCIENCE, INC.
 Denver, Colorado



Soil samples were shipped via Federal Express® to the Pace, Inc. laboratory for chemical and physical analysis. Soil samples were analyzed for total recoverable petroleum hydrocarbons (TRPH); benzene, toluene, ethylbenzene and xylenes (BTEX); iron; alkalinity; total Kjeldahl nitrogen (TKN); and several physical parameters. One sample containing a composite of the drill cuttings from both FT-01 and SS-18 was analyzed for volatiles, BTEX, TRPH, and lead to characterize the soil for disposal. The results of these analyses are provided in Table 2.1.

Results for BTEX compounds in the soil samples appear low when compared to the concentrations of hydrocarbons at the site. This is a typical characteristic of JP-4 fuel and fuel residuals.

Analytical results for the composite sample of drill cuttings from both sites indicate very low concentrations of TRPH and moderate concentrations of lead in the cuttings [12 and 17 milligrams per kilogram (mg/Kg), respectively].

2.1.2 Exceptions To Test Protocol Document Procedures

Procedures described in the protocol document (Hinchee et al., 1992) were used during drilling operations at FT-01. During the drilling of the proposed VW at FT-01 groundwater was encountered at approximately 6 feet bgs. The water quickly rose to 4 feet, making the site no longer suitable for a bioventing system. Several exploratory borings were then completed in an attempt to both define the area of contamination and to find a location where deeper groundwater would permit the installation of a bioventing system (Figure 1.1). Groundwater was consistently encountered between 4 and 6 feet bgs in borings throughout the area. One MP was installed at a depth of 4 feet bgs. This point was later flooded by groundwater. It was then decided that bioventing testing site FT-01 should be abandoned. Boreholes were abandoned by backfilling to the surface with bentonite chips. Prior to abandoning the site, analytical soil samples were collected to provide additional information about the nature and extent of contamination at the site. These samples were collected and analyzed in accordance with the protocol document. Soil gas samples could not be collected at the site due to shallow groundwater. Should groundwater levels recede in the future, the one MP installed at the site may be used to sample soil gas.

2.2 Site SS-18, Spill Site 18

2.2.1 Sampling Results

Soils at this site consist of a gravelly loam to a depth of approximately 4 feet, gravelly clay from approximately 4 to 7 feet, and silty clay below 7 feet (Figure 1.6). The bedrock was not encountered during drilling for this pilot test and is not shown in the figure. Groundwater was encountered at 8 feet bgs in the VW and MP boreholes. Boring logs for the MPs and VW are included in Appendix A.

Based on sampling results, it is believed that the majority of the contamination at site SS-18 exists in a very narrow band just above groundwater. The soil samples from the site were taken approximately 2 feet above the water table and are not

TABLE 2.1
SOIL ANALYTICAL RESULTS
SITE FT-01
LITTLE ROCK AFB, ARKANSAS

Analyte (Units) ^{a/}	Sample Location-Depth (feet below ground surface)		
	MPA-4	MPB-3.5	MPC-3.5
<u>Soil Hydrocarbons</u>			
TRPH (mg/kg)	1120	780	1080
Benzene (mg/kg)	ND ^{b/}	ND	ND
Toluene (mg/kg)	ND	ND	ND
Ethylbenzene (mg/kg)	ND	ND	ND
Xylenes (mg/kg)	1.0	ND	ND
<u>Soil Inorganics</u>	<u>MPA-4</u>	<u>MPB-3.5</u>	<u>MPC-3.5</u>
Iron (mg/kg)	54,700	51,900	52,400
Alkalinity (mg/kg as CaCO ₃)	ND	ND	210
pH (units)	5.4	6.0	6.8
TKN (mg/kg)	630	660	830
Phosphates (mg/kg)	140	120	140
<u>Soil Physical Parameters</u>	<u>MPA-4</u>	<u>MPB-3.5</u>	<u>MPC-3.5</u>
Moisture (% wt.)	19	18	20
Gravel (%)	0.6	0.7	0.6
Sand (%)	15.5	22.5	15.5
Silt (%)	47.4	42.6	47.4
Clay (%)	36.5	34.2	36.5

a/ mg/kg=milligrams per kilogram; CaCO₃=calcium carbonate; TKN=total Kjeldahl nitrogen; TRPH=total recoverable petroleum hydrocarbons.

b/ ND=not detected.

representative of this narrow band. This may explain the very low concentrations of TRPH and BTEX. Soil gas samples indicate high concentrations of TVH and some BTEX compounds. This can be attributed to vapors migrating from the narrow area of contamination into less contaminated soils above the groundwater. The slight odor noted during drilling at the site is also probably due to vapors migrating from below.

Soil samples for laboratory analysis were collected from split-spoon samplers and placed in 4-ounce glass sample jars with Teflon seals. Soil samples were screened for VOCs using a PID to determine the presence of contamination and to select soil samples for laboratory analysis. Soil samples for laboratory analysis were collected from depths of 4.5 feet from MPA, 3.5 feet from MPC, and 4 feet from the VW. A background soil sample was collected from the background MP borehole at a depth of 3.5 feet. One additional soil sample was collected for drill cutting waste characterization. Soil gas samples were collected by extracting soil gas from the completed VW, and from depths of 6.5 feet from MPA and 3.5 feet from MPC.

Soil samples were shipped via Federal Express® to the Pace, Inc. laboratory for chemical and physical analysis. Soil samples from the MPs were analyzed for TRPH, BTEX, iron, alkalinity, TKN, and several physical parameters. The background soil sample was analyzed only for nutrients. One sample containing a composite of the drill cuttings from both FT-01 and SS-18 was analyzed for volatiles, BTEX, TRPH, and lead to characterize the soil for disposal. Soil gas samples were shipped via Federal Express® to Air Toxics, Ltd. in Folsom, California for TVH and BTEX analysis. The results of these analyses are provided in Table 2.2.

Analytical results for the composite sample of drill cuttings from both sites indicate very low concentrations of TRPH and lead in the cuttings (12 and 17 mg/kg, respectively). All other potential contaminants of concern were not detected.

2.2.2 Exceptions To Test Protocol Document Procedures

Procedures described in the protocol document (Hinchee et al., 1992) were used to complete treatability tests at SS-18 with three exceptions. A soil sample was collected from MPC instead of from MPB, the respiration test was performed prior to the permeability test, and MP and VW construction was completed using No. 8-12 sand instead of No. 6-9.

3.0 PILOT TEST RESULTS

3.1 Site FT-01, Fire Training Area

Due to shallow groundwater at site FT-01 a pilot test was not performed and an extended pilot test system was not installed.

3.2 Site SS-18, Spill Site 18

3.2.1 Initial Soil Gas Chemistry

Prior to initiating any air injection, all MPs were purged until oxygen levels had stabilized, and initial oxygen, carbon dioxide, and TVH concentrations were sampled using portable gas analyzers, as described in the technical protocol document (Hinchee et al., 1992). At all MP screened intervals and at the VW, microorganisms had

TABLE 2.2
SOIL AND SOIL GAS ANALYTICAL RESULTS
SITE SS-18
LITTLE ROCK AFB, ARKANSAS

Analyte (Units) ^{a/}	Sample Location-Depth (feet below ground surface)		
	VW 3-10	MPA-6.5	MPC-3.5
<u>Soil Gas Hydrocarbons</u>			
TVH (ppmv)	16,000	43,000	12,000
Benzene (ppmv)	ND ^{b/}	ND	ND
Toluene (ppmv)	ND	ND	ND
Ethylbenzene (ppmv)	5	14	7.2
Xylenes (ppmv)	14	16	17
<u>Soil Hydrocarbons</u>	<u>VW-4</u>	<u>MPA-4.5</u>	<u>MPC-3.5</u>
TRPH (mg/kg)	13	8.7	ND
Benzene (mg/kg)	ND	ND	ND
Toluene (mg/kg)	ND	ND	ND
Ethylbenzene (mg/kg)	0.50	1.1	0.0021
Xylenes (mg/kg)	0.50	1.7	0.017
<u>Soil Inorganics</u>	<u>VW-4</u>	<u>MPA-4.5</u>	<u>MPC-3.5</u>
Iron (mg/kg)	43,200	44,900	20,800
Alkalinity (mg/kg as CaCO ₃)	ND	ND	ND
pH (units)	6.1	6.0	6.1
TKN (mg/kg)	440	410	310
Phosphates (mg/kg)	160	120	140
<u>Soil Physical Parameters</u>	<u>VW-4</u>	<u>MPA-4.5</u>	<u>MPC-3.5</u>
Moisture (% wt.)	15	18	16
Gravel (%)	0.0	4.1	2.1
Sand (%)	18.8	14.7	16.1
Silt (%)	49.1	48.7	54.7
Clay (%)	32.0	32.5	27.1

a/ mg/kg=milligrams per kilogram, ppmv=parts per million, volume per volume; CaCO₃=calcium carbonate; TKN=total Kjeldahl nitrogen; TVH=total volatile hydrocarbons; TRPH=total recoverable petroleum hydrocarbons.

b/ ND=not detected.

depleted soil gas oxygen supplies, indicating significant soil or soil vapor contamination. Table 3.1 summarizes the initial soil gas chemistry.

3.2.2 Air Permeability

An air permeability test was conducted according to protocol document procedures. Air was injected into the VW for approximately 19 hours at a rate of approximately 16 scfm and an average pressure of 48 inches of water. The maximum pressure response at each MP are presented in Table 3.2. The pressure measured at the MPs increased slowly during the period of air injection. Due to the slow pressure response, the steady-state method of determining air permeability was selected. A soil gas permeability value of 2.3 darcys, typical for silty clay soils, was calculated for this site. A radius of pressure influence of at least 30 feet was observed at the 3.5- and 6.5-foot depths.

3.2.3 Oxygen Influence

The depth and radius of oxygen increase in the subsurface resulting from air injection into the central VW during pilot testing is the primary design parameter for full-scale bioventing systems. Optimization of full-scale and multiple VW systems requires pilot testing to determine the volume of soil that can be oxygenated at a given flow rate and VW screen configuration.

Table 3.3 presents the change in soil gas oxygen levels that occurred during the 19-hour air permeability test. This period of air injection at approximately 16 scfm produced changes in soil gas oxygen levels at all of the MP screened intervals. One point, MPB-7.5, was not available for sampling after it became flooded with groundwater. Based on measured changes in oxygen levels, it is anticipated that the radius of influence for a long-term bioventing system at this site will exceed 30 feet at all depths. Monitoring during the extended pilot test at this site will better define the effective treatment radius.

3.2.4 In Situ Respiration Rates

The *in situ* respiration test was performed by injecting a mixture of air (oxygen) and approximately 1.5 percent helium (inert tracer gas) into the VW and three MP screened intervals (MPA-6.5, MPB-4.5, and MPC-3.5) for an 18.5-hour period. Oxygen loss and other changes in soil gas composition over time were then measured at these points. One additional point, MPA-3.5, had elevated oxygen levels following the air injection at MPA-6.5 and was also monitored during the respiration test. Oxygen, TVH, carbon dioxide, and helium were measured for a period of 24 hours following air injection. The measured oxygen loss was then used to calculate the biological oxygen utilization rate. The results of *in situ* respiration testing at selected points at this site are presented in Figures 3.1 through 3.4. Additional results are included in Appendix A. Table 3.4 provides a summary of the oxygen utilization rates.

Because helium is a conservative, inert gas, the change in helium concentrations over time can be useful in determining the effectiveness of the bentonite seals between MP screened intervals. Figures 3.1 through 3.4 compare oxygen utilization

TABLE 3.1
INITIAL SOIL GAS CHEMISTRY
SITE SS-18
LITTLE ROCK AFB, ARKANSAS

Sample Location	Depth (ft)	O ₂ (%)	CO ₂ (%)	Field TVH (ppmv) ^{a/}	Lab TVH (ppmv) ^{b/}	Soil TRPH (mg/kg) ^{c/}	
MPA	3.5	0.0	10.0	520	NS ^{d/}	NS	
MPB	4.5	0.0	9.5	670	NS	NS	
MPC	3.5	0.0	10.0	1,600	12,000	ND ^{e/}	
MPA	6.5	0.0	10.5	1,000	43,000	NS	
MPB	7.5	Not Sampled - Interval Flooded by Groundwater					
MPC	6.5	0.0	11.0	1,400	NS	NS	
VW	3-10	0.0	9.5	2,600	16,000	13 ^{f/}	

a/ Field screening results for total volatile hydrocarbons (TVH), in parts per million, volume per volume (ppmv).

b/ Laboratory results.

c/ Laboratory soil results for total recoverable petroleum hydrocarbons (TRPH), in milligrams per kilogram (mg/kg).

d/ NS=not sampled.

e/ ND=not detected.

f/ Sample collected at a depth of 4 feet.

TABLE 3.2
MAXIMUM PRESSURE RESPONSE
AIR PERMEABILITY TEST
SITE SS-18
LITTLE ROCK AFB, ARKANSAS

	Distance from injection well (VW) (feet)					
	9 (MPA)		19.5 (MPB)		30.5 (MPC)	
Depth (feet)	3.5	6.5	4.5	7.5	3.5	6.5
Time (min)	565	565	565	NS ^{a/}	565	180
Max Press. (inches H ₂ O)	.93	1.05	.87	NS	.185	1.25

^{a/} NS = Not sampled, interval was flooded with groundwater.

TABLE 3.3
INFLUENCE OF AIR INJECTION AT VENT WELL
ON MONITORING POINT OXYGEN LEVELS
SITE SS-18
LITTLE ROCK AFB, ARKANSAS

MP	Distance From VW (ft)	Depth(ft)	Initial O ₂ (%)	Final O ₂ (%) ^{a/}
A	9	3.5	0.0	19.8
B	19.5	4.5	0.0	17.2
C	30.5	3.5	0.0	15.0
A	9	6.5	0.0	18.8
B	19.5	7.5	NS ^{b/}	NS
C	30.5	6.5	0.0	10.8

a/ Reading taken at end of 19-hour air permeability test.

b/ NS = Not sampled, interval flooded by groundwater.

Figure 3.1
 Respiration Test
 Oxygen and Helium Concentrations
 Site SS-18, VW
 Little Rock AFB, Arkansas

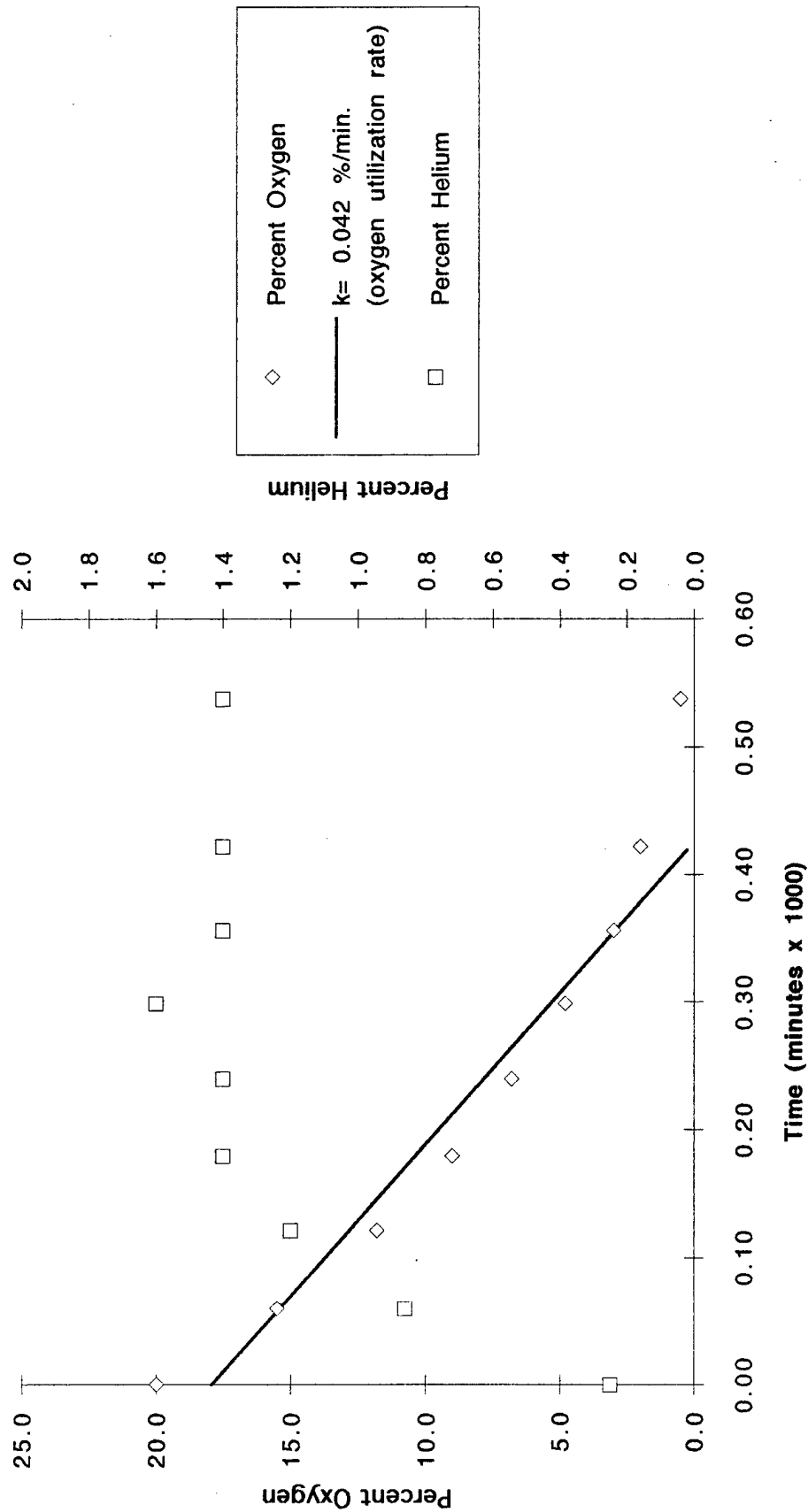

Figure 3.2
 Respiration Test
 Oxygen and Helium Concentrations
 Site SS-18, MPA-6.5
 Little Rock AFB, Arkansas

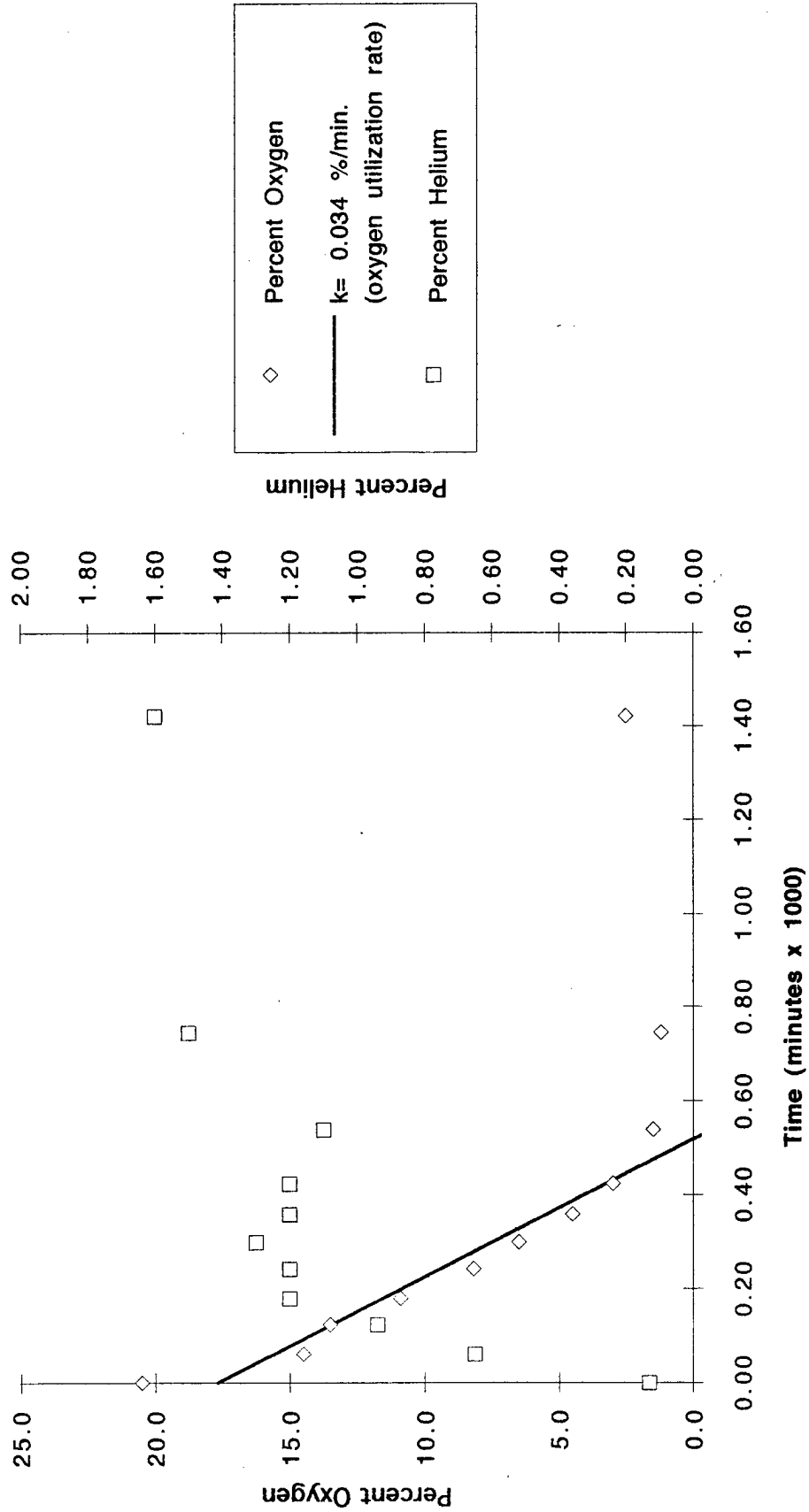

Figure 3.3
 Respiration Test
 Oxygen and Helium Concentrations
 Site SS-18, MPB-4.5
 Little Rock AFB, Arkansas

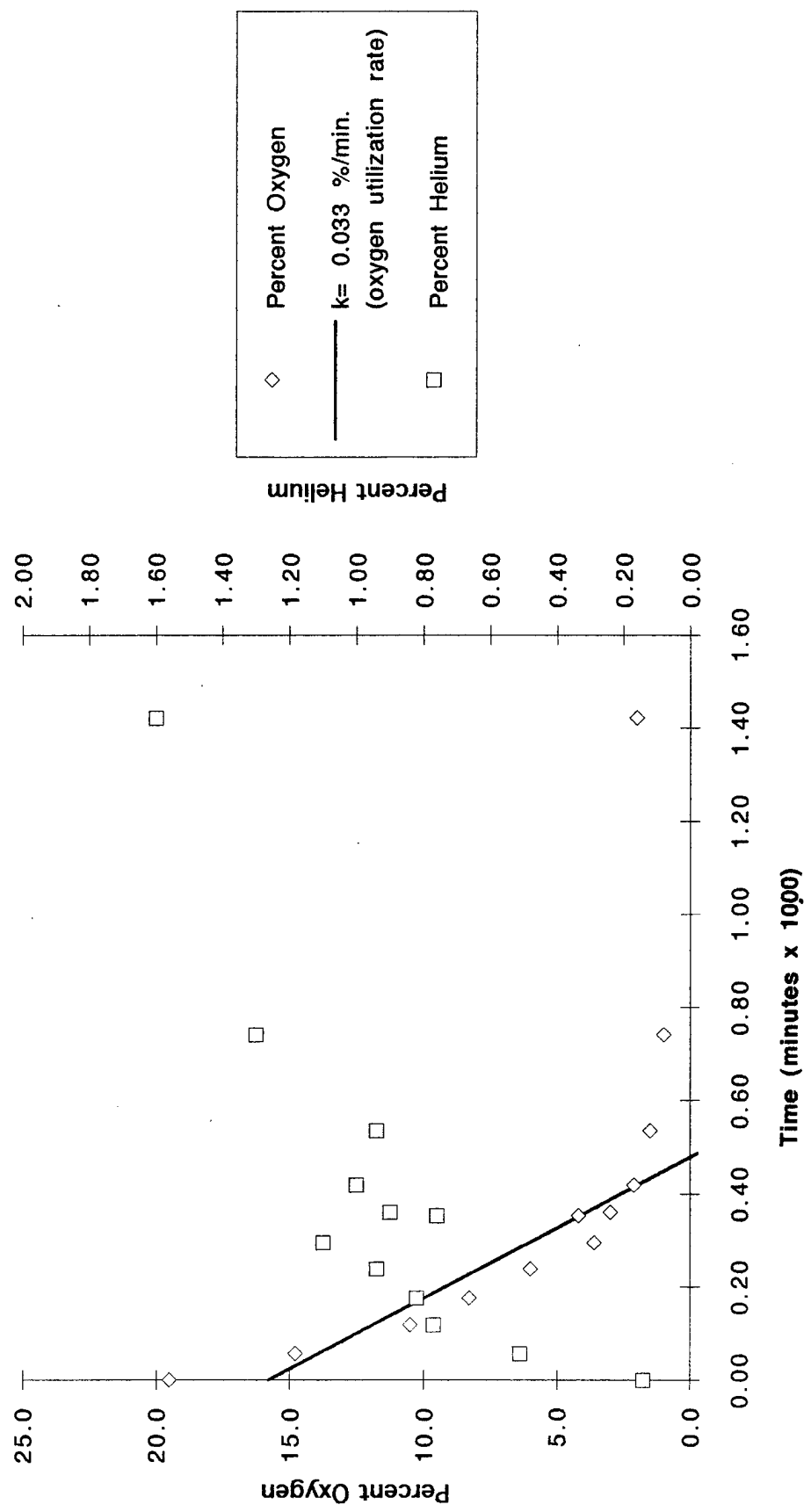

Figure 3.4
 Respiration Test
 Oxygen and Helium Concentrations
 Site SS-18, MPA-3.5
 Little Rock AFB, Arkansas

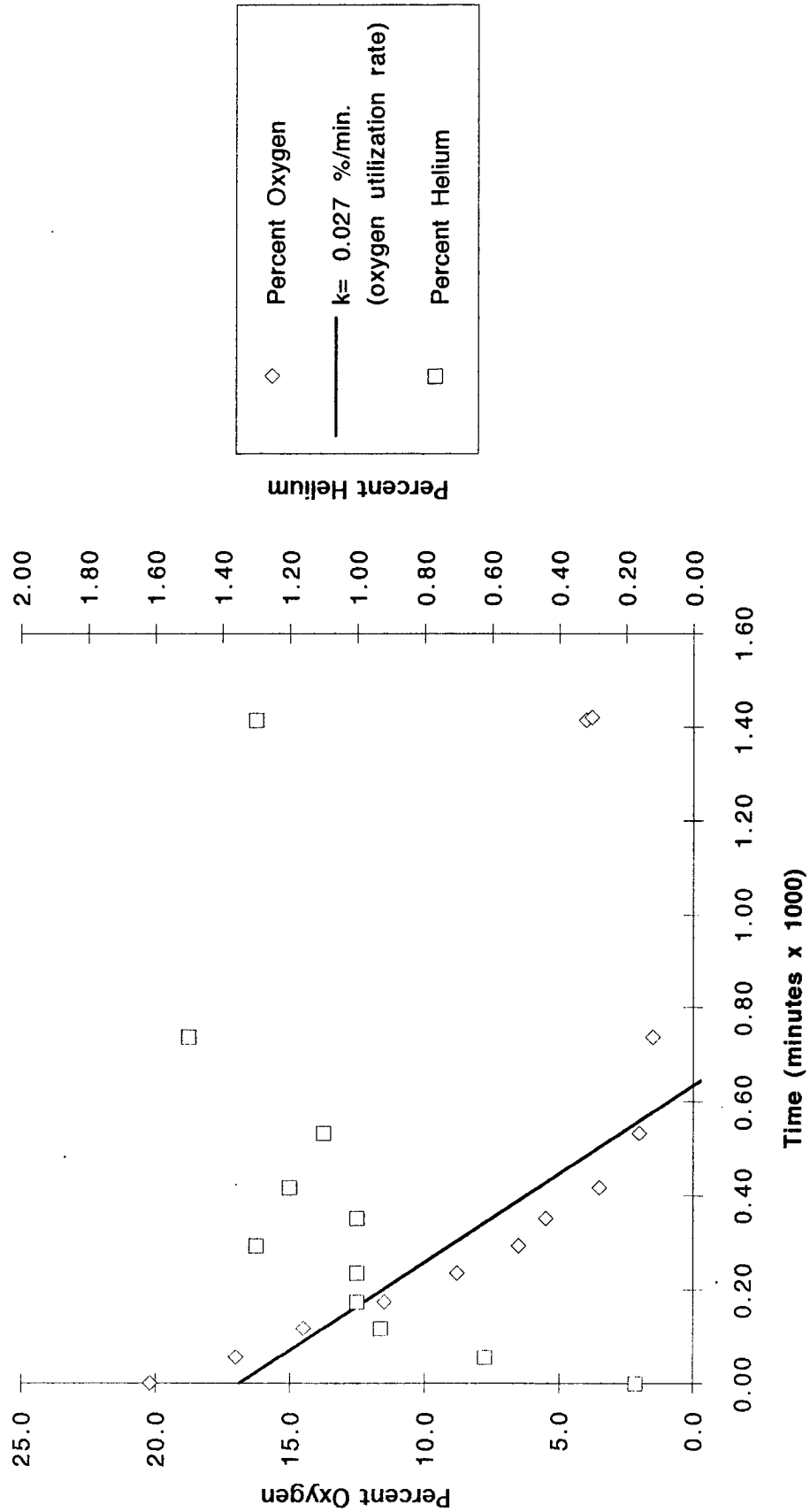

TABLE 3.4
OXYGEN UTILIZATION RATES
SITE SS-18
LITTLE ROCK AFB, ARKANSAS

Location	O ₂ Loss ^{a/} (%)	Test ^{b/} Duration (min)	O ₂ Utilization ^{c/} Rate (%/min)
MPA-3.5	18.7	734	0.0266
MPA-6.5	19.3	749	0.0341
MPB-4.5	18.5	734	0.0330
VW	19.5	533	0.0421

a/ Actual measured oxygen loss.

b/ Elapsed time from beginning of test to time when minimum oxygen concentration was measured.

c/ Values based on best-fit lines (Figures 3.1 through 3.4).

and helium retention at the VW, MPA-3.5, MPA-6.5, and MPB-4.5 respectively. Because the observed helium loss was negligible, and because helium will diffuse approximately three times faster than oxygen due to oxygen's greater molecular weight, the measured oxygen loss is the result of bacterial respiration and not due to faulty MP construction.

Results from this test indicate all of the MP screened intervals that were sampled had significant hydrocarbon contamination. All of these points had initial oxygen concentrations of 0 percent and initial TVH concentrations exceeding 520 parts per million, volume per volume (ppmv). Analytical soil gas sample collected from the VW, MPA-6.5, and MPC-3.5, had TVH concentrations of 16,000, 43,000, and 12,000 ppmv, respectively. Oxygen loss occurred at high rates, ranging from 0.027 percent per minute at MPA-3.5 to 0.042 percent per minute at the VW. At the VW, the oxygen dropped from 20.0 percent to 0.5 percent in 540 minutes.

Based on these oxygen utilization rates, an estimated 1,070 to 1,370 milligrams (mg) of fuel per kilogram (kg) of soil can be degraded each year at this site. This conservative estimate is based on an average air-filled porosity of approximately 0.02 liter per kg of soil, and a ratio of 3.5 mg of oxygen consumed for every 1 mg of fuel biodegraded. Fuel vapors above the water table will be rapidly degraded at these rates and oxygen supplied to the capillary fringe will begin to biodegrade this more concentrated fuel interval.

3.2.5 Potential Air Emissions

The long-term potential for air emissions from full-scale bioventing operations at this site is low because of the low injection rate. Emissions should be minimal because accumulated vapors will move slowly outward from the air injection point and will be biodegraded as they move horizontally through the soil.

4.0 RECOMMENDATIONS

4.1 Site FT-01, Fire Training Area

The shallow groundwater discovered during drilling at this site and the fact that most of the contamination is at or below the water table, does not allow the installation of a vertical or horizontal (trench) air injection system. A MP has been installed at a depth of 4 feet at the site. This MP was found to be below groundwater soon after construction. It is recommended that this MP be monitored during subsequent site visits by ES. If it appears that groundwater has receded, then the site can be reevaluated for potential installation of a bioventing pilot test system.

4.2 Site SS-18, Spill Site 18

Initial bioventing tests at this site indicate that oxygen has been depleted in the contaminated soils, and that air injection is an effective method of increasing aerobic fuel biodegradation. AFCEE has recommended that air injection continue at this site to determine the long-term radius of oxygen influence and the effect of time, available nutrients, and changing temperatures on fuel biodegradation rates.

A small, 1-horsepower regenerative blower has been installed at the site to continue air injection at a rate of approximately 10 scfm. The 314th CES electrical project to

supply power to the blower unit is scheduled to be completed by the end of 1993. Six months after the blower unit is brought on-line, ES will return to the site to sample and analyze the soil gas and conduct a respiration test. One year after blower startup, a final respiration test will be conducted, and soil and soil gas samples will be collected from the site to determine the degree of remediation achieved during the first year of *in situ* treatment.

Based on the results of the first year of pilot-scale bioventing, AFCEE will recommend one of three options:

1. Upgrade, if necessary, and continue operation of the bioventing system for full-scale remediation of the site. AFCEE can assist the base in obtaining regulatory approval for upgrading and continued operation.
2. If final soil sampling indicates significant contaminant removal has occurred, AFCEE may recommend additional sampling to confirm that cleanup criteria have been achieved.
3. If significant difficulties or poor results are encountered during bioventing at this site, AFCEE may recommend removal of the blower system and proper abandonment of the VW and MPs.

5.0 REFERENCES

Hinchee, R.E., S.K. Ong., R.N. Miller, D.C. Downey, and R. Frandt. 1992. *Test Plan and Technical Protocol for a Field Treatability Test for Bioventing*. Prepared for USAF Center for Environmental Excellence. May.

**APPENDIX A
GEOLOGIC BORING LOGS,
CHAIN-OF-CUSTODY FORMS,
TEST DATA, AND CALCULATIONS**

GEOLOGIC BORING LOG

BORING NO.: FT01-VW	CONTRACTOR: P.S.I.	DATE SPUD: 7/21/93
CLIENT: AFCEE	RIG TYPE: CME 75	DATE CMPL: 7/21/93
JOB NO: DE268.46.04	DRLG METHOD: HSA	ELEVATION:
LOCATION: LITTLE ROCK AFB	BORING DIA: 11"	TEMP: 98°F
GEOLOGIST: BR VANDERGLAS	DRLG FLUID: NONE	WEATHER: CLEAR, HUMID

COMMENTS

Depth (ft.)	Pro-file	USCS	Geologic Description	Samples		Sample Type	Blow Counts	Remarks TIP = Bkgnd/Reading(ppm)
				No.	Depth (ft)			
1								No odors
2			Light brown and olive gray loam with fine to medium gravel, damp			D	6	3' Recovery
3								
4								
5								
6			Brownish red and olive gray gravelly clay, fine to small gravel, very plastic, moist			D	7	Very slight odors 6" Recovery
7				FT01-VW:7	7	D	25	Slight odors 2' Recovery
8			Mottled brown and olive gray, brownish red silty clay, very firm, some small gravel					Headspace = 18 ppm Water hit @ 8.0 ft.
9			Light brown silty clay with some coarse sand, very moist			D	11 22	No odors Headspace = 48 ppñ
10			Olive gray to light gray shale, very firm (flaking), no odors				45	18" Recovery
								Total Depth = 10.0 ft.
11								
12								
13								
14								
15								

sl - slight	v - very	NO/NS - no odor/ no stain	fm - fine	<input checked="" type="checkbox"/> D SPLIT SPOON SAMPLE
tr - trace	kt - light	HSA - Hollow stem	m - medium	<input type="checkbox"/> CUTTINGS SAMPLE
sm - some	dk - dark	auger	crs - coarse	<input checked="" type="checkbox"/> S SHELBY TUBE SAMPLE
& - and	bf - buff	SSA - Solid stem	BH - Bore Hole	- - - EST. WATER TABLE
@ - at	brn - brown	auger	SAA - Same As Above	
w - with	blk - black		M.S.L. - Mean Sea Level	

GEOLOGIC BORING LOG

BORING NO.: FT01-MPC	CONTRACTOR: P.S.I.	DATE SPUD: 7/21/93
CLIENT: AFCEE	RIG TYPE: CME 75	DATE CMLP: 7/21/93
JOB NO: DE268.46.04	DRLG METHOD: HSA	ELEVATION:
LOCATION: LITTLE ROCK AFB	BORING DIA: 8"	TEMP: 85°F
GEOLOGIST: BR VANDERGLAS	DRLG FLUID: NONE	WEATHER: SUNNY
COMMENTS		

Depth (ft.)	Pro-file	USCS	Geologic Description	Samples		Sample Type	Blow Counts	Remarks TIP = Bkgnd/Reading(ppm)
				No.	Depth (ft)			
1						D	6 10	6" Recovery
							14	No odors
2			Light brown and olive gray loam with medium gravel			D	5	Slight odor
							3	6" Recovery
3							3	Headspace = 38 ppm
							3	Slight odor
4			Brownish red and olive gray gravelly clay, fine to medium gravel, plastic, moist			D	3	6" Recovery
							4	Headspace = 180 ppm
5							4	No odors
							7	9" Recovery
6			Mottled brownish red, gray, black, silty clay with trace gravel (small to medium), very firm, slightly damp			D	9	Total depth = 6.0 ft.
7								
8								
9								
10								
11								
12								
13								
14								
15								

sl - slight	v - very	NO/NS - no odor/ no stain	fm - fine	D SPLIT SPOON SAMPLE
tr - trace	kt - light	HSA - Hollow stem auger	m - medium	 CUTTINGS SAMPLE
sm - some	dk - dark	SSA - Solid stem auger	crs - coarse	S SHELBY TUBE SAMPLE
& - and	bf - buff		BH - Bore Hole	
@ - at	brn - brown		SAA - Same As Above	
w - with	blk - black		M.S.L. - Mean Sea Level	

- - - EST. WATER TABLE

GEOLOGIC BORING LOG

BORING NO.:	FT01-MPA(2)	CONTRACTOR:	P.S.I.	DATE SPUD:	7/23/93
CLIENT:	AFCEE	RIG TYPE:	CME 75	DATE CMPL:	7/23/93
JOB NO.:	DE268.46.04	DRLG METHOD:	HSA	ELEVATION:	
LOCATION:	LITTLE ROCK AFB	BORING DIA.:	8"	TEMP:	87°F
GEOLOGIST:	BR VANDERGLAS	DRLG FLUID:	NONE	WEATHER:	SUNNY, HUMID

COMMENTS

Depth (ft.)	Pro-file	USCS	Geologic Description	Samples		Sample Type	Blow Counts	Remarks TIP = Bkgnd/Reading(ppm)
				No.	Depth (ft)			
1								
2								
3								
4			Gray gravelly loam, increasing clay with depth Olive gray to dark brown gravelly clay, some large cobbles. damp to moist, odors	FT01-MPA	4-4.5	S		Log from cuttings 0-3.5' Headspace = 1800 ppm Total depth = 4.5 ft.
5								
6								
7								
8								
9								
10								
11								
12								
13								
14								
15								

sl - slight	v - very	NO/NS - no odor/ no stain	fm - fine	<input type="checkbox"/> D	SPLIT SPOON SAMPLE
tr - trace	kt - light	HSA - Hollow stem	m - medium	<input type="checkbox"/>	CUTTINGS SAMPLE
sm - some	dk - dark	auger	crs - coarse	<input type="checkbox"/> S	SHELBY TUBE SAMPLE
& - and	bf - buff	SSA - Solid stem	BH - Bore Hole	- - -	EST. WATER TABLE
@ - at	brn - brown	auger	SAA - Same As Above		
w - with	blk - black		M.S.L. - Mean Sea Level		

GEOLOGIC BORING LOG

BORING NO.: FT01-MPB(2)	CONTRACTOR: P.S.I.	DATE SPUD: 7/23/93
CLIENT: AFCEE	RIG TYPE: CME 75	DATE CMPL: 7/23/93
JOB NO: DE268.46.04	DRLG METHOD: HSA	ELEVATION: _____
LOCATION: LITTLE ROCK AFB	BORING DIA: 8"	TEMP: 85°F
GEOLOGIST: BR VANDERGLAS	DRLG FLUID: NONE	WEATHER: SUNNY, CALM, VERY HUMID

COMMENTS

Depth (ft.)	Pro-file	USCS	Geologic Description	Samples		Sample Type	Blow Counts	Remarks TIP = Bkgnd/Reading(ppm)
				No.	Depth (ft)			
1								
2								
3			Light gray gravelly loam with medium to coarse pebbles, increasing clay with depth, dry					No odors Log from cuttings 0-3'
4			Olive gray and dark brown gravelly clay, damp	FT01-MPB	3.5-4	S		No recovery splitspoon Headspace = 1200 ppm Total depth = 4.5 ft.
5								
6								
7								
8								
9								
10								
11								
12								
13								
14								
15								

sl - slight	v - very	NO/NS - no odor/ no stain	fm - fine
tr - trace	kt - light	HSA - Hollow stem auger	m - medium
sm - some	dk - dark	SSA - Solid stem auger	crs - coarse
& - and	bf - buff		BH - Bore Hole
@ - at	brn - brown		SAA - Same As Above
w - with	blk - black		M.S.L. - Mean Sea Level

D	SPLIT SPOON SAMPLE
	CUTTINGS SAMPLE
S	SHELBY TUBE SAMPLE
- - -	EST. WATER TABLE

GEOLOGIC BORING LOG

BORING NO.: FT01-MPC(2)	CONTRACTOR: P.S.I.	DATE SPUD: 7/23/93
CLIENT: AFCEE	RIG TYPE: CME 75	DATE CMPL: 7/23/93
JOB NO: DE268.46.04	DRLG METHOD: HSA	ELEVATION:
LOCATION: LITTLE ROCK AFB	BORING DIA: 8"	TEMP: 80°F
GEOLOGIST: BR VANDERGLAS	DRLG FLUID: NONE	WEATHER: SUNNY, HUMID
COMMENTS: NEXT TO EX 3 SOIL BORING WITH MP'S (OR MPC-(1))		

Depth (ft.)	Pro-file	USCS	Geologic Description	Samples		Sample Type	Blow Counts	Remarks TIP = Bkgnd/Reading(ppm)
				No.	Depth (ft)			
1								
2								
3			Light gray gravelly loam, increasing clay with depth, medium to coarse gravel, dry					Log from cuttings 0-3'
4			Olive gray and dark brown gravelly clay with fine pebbles / coarse sand	FT01-MPC	3.5-4	S		Headspace = 700 ppm No recovery splitspoon
5			Reddish brown silty clay, very firm, some fine to medium gravel, slightly damp			D		Headspace = 780 ppm Splitspoon to 5.5' Total depth = 5.5 ft.
6								
7								
8								
9								
10								
11								
12								
13								
14								
15								

sl - slight	v - very	NO/NS - no odor/ no stain	fm - fine	D SPLIT SPOON SAMPLE
tr - trace	kt - light	HSA - Hollow stem auger	m - medium	 CUTTINGS SAMPLE
sm - some	dk - dark	SSA - Solid stem auger	crs - coarse	S SHELBY TUBE SAMPLE
& - and	bf - buff		BH - Bore Hole	
@ - at	brn - brown		SAA - Same As Above	
w - with	blk - black		M.S.L. - Mean Sea Level	
				- - - EST. WATER TABLE

GEOLOGIC BORING LOG

BORING NO.: SS18-BGMP	CONTRACTOR: P.S.I.	DATE SPUD: 7/23/93
CLIENT: AFCEE	RIG TYPE: CME 75	DATE CMPL: 7/23/93
JOB NO: DE268.46.04	DRLG METHOD: HSA	ELEVATION:
LOCATION: LITTLE ROCK AFB	BORING DIA: 8"	TEMP: 90°F
GEOLOGIST: BR VANDERGLAS	DRLG FLUID: NONE	WEATHER: SUNNY, HUMID
COMMENTS		

Depth (ft.)	Pro-file	USCS	Geologic Description	Samples		Sample Type	Blow Counts	Remarks TIP = Bkgnd/Reading(ppm)
				No.	Depth (ft)			
1								
2								
3			Light reddish brown and gray gravelly loam, dry					Log from cuttings 0-3'
4			Reddish brown silty clay with some fine to coarse gravel fragments, plastic, damp	SS18-BGMP	3-4	D		6" Recovery Headspace = 0 ppm No odors
5						D		Headspace = 50 ppm 8" recovery No odors
6								Log from cuttings 6-7'
7			Light brown silty clay, damp					Total depth = 7.0 ft.
8								
9								
10								
11								
12								
13								
14								
15								

sl - slight	v - very	NO/NS - no odor/ no stain	fm - fine	<input checked="" type="checkbox"/> D	SPLIT SPOON SAMPLE
tr - trace	kt - light	HSA - Hollow stem auger	m - medium	<input type="checkbox"/>	CUTTINGS SAMPLE
sm - some	dk - dark	SSA - Solid stem auger	crs - coarse	<input checked="" type="checkbox"/> S	SHELBY TUBE SAMPLE
& - and	bf - buff	M.S.L. - Mean Sea Level	BH - Bore Hole		
@ - at	brn - brown		SAA - Same As Above		
w - with	blk - black				

- - - EST. WATER TABLE

GEOLOGIC BORING LOG

BORING NO.: SS18-MPA	CONTRACTOR: P.S.I.	DATE SPUD: 07/22/93
CLIENT: AFCEE	RIG TYPE: CME 75	DATE CMPL: 07/22/93
JOB NO: DE268.46.04	DRLG METHOD: HSA	ELEVATION:
LOCATION: LITTLE ROCK AFB	BORING DIA: 8"	TEMP: 87°F
GEOLOGIST: BR VANDERGLAS	DRLG FLUID: NONE	WEATHER: SUNNY, CALM
COMMENTS		

Depth (ft.)	Pro-file	USCS	Geologic Description	Samples		Sample Type	Blow Counts	Remarks TIP = Bkgmd/Reading(ppm)
				No.	Depth (ft)			
1								
2								
3			Light reddish brown gravelly loam, small to medium gravel, dry					No odors
4			Brown silty clay with fine to medium gravel			D		Log from cuttings 0-3.5' Headspace = 180 ppm
5						S		Odors Headspace = 300 ppm
6								
7								
8			Dark gray and brown sandy clay w/ many medium to large shaly pebbles and cobbles, damp					Odors Total depth = 8.0 ft.
9								
10								
11								
12								
13								
14								
15								

sl - slight	v - very	NO/NS - no odor/ no stain	fm - fine	<input type="checkbox"/> D	SPLIT SPOON SAMPLE
tr - trace	kt - light	HSA - Hollow stem auger	m - medium	<input type="checkbox"/>	CUTTINGS SAMPLE
sm - some	dk - dark	SSA - Solid stem auger	crs - coarse	<input type="checkbox"/> S	SHELBY TUBE SAMPLE
& - and	bf - buff		BH - Bore Hole		
@ - at	brn - brown		SAA - Same As Above		
w - with	blk - black		M.S.L. - Mean Sea Level		
					- - - EST. WATER TABLE

GEOLOGIC BORING LOG

BORING NO.:	SS18-MPB	CONTRACTOR:	P.S.I.	DATE SPUD:	07/21/93
CLIENT:	AFCEE	RIG TYPE:	CME 75	DATE CMPL:	07/22/93
JOB NO:	DE268.46.04	DRLG METHOD:	HSA	ELEVATION:	
LOCATION	LITTLE ROCK AFB	BORING DIA:	8"	TEMP:	87°F
GEOLOGIST	BR VANDERGLAS	DRLG FLUID:	NONE	WEATHER:	SUNNY, HUMID
COMMENTS	5' BOREHOLE (6.5" DIAMETER) OVERDRILLED TO CONSTRUCT MPB (EXP 5)				

Depth (ft.)	Pro-file	USCS	Geologic Description	Samples		Sample Type	Blow Counts	Remarks TIP = Bkgnd/Reading(ppm)
				No.	Depth (ft)			
1								
2								
3								
4			Light reddish brown loam with small to medium gravel Increasing clay content with depth					
5								
6								
7			Brown sandy clay with gravel, damp	No samples collected				Log from cuttings 0-6.5'
8			Brownish red, gray mottled silty clay, firm, small to medium gravel and pebbles, slightly damp			D		9" Recovery Headspace = 120 ppm Total depth = 8.0 ft.
9								
10								
11								
12								
13								
14								
15								

sl - slight	v - very	NO/NS - no odor/ no stain	fm - fine	<input type="checkbox"/> D	SPLIT SPOON SAMPLE
tr - trace	kt - light	HSA - Hollow stem auger	m - medium	<input type="checkbox"/>	CUTTINGS SAMPLE
sm - some	dk - dark	SSA - Solid stem auger	crs - coarse	<input type="checkbox"/> S	SHELBY TUBE SAMPLE
& - and	bf - buff		BH - Bore Hole		
@ - at	brn - brown		SAA - Same As Above		
w - with	blk - black		M.S.L. - Mean Sea Level		
					- - - EST. WATER TABLE

GEOLOGIC BORING LOG

BORING NO.: SS18-MPC	CONTRACTOR: P.S.I.	DATE SPUD: 07/22/93
CLIENT: AFCEE	RIG TYPE: CME 75	DATE CMPL: 07/22/93
JOB NO: DE268.46.04	DRLG METHOD: HSA	ELEVATION:
LOCATION: LITTLE ROCK AFB	BORING DIA: 8"	TEMP: 80°F
GEOLOGIST: BR VANDERGLAS	DRLG FLUID: NONE	WEATHER: SUNNY, CALM

Depth (ft.)	Pro-file	USCS	Geologic Description	Samples		Sample Type	Blow Counts	Remarks TIP = Bkgnd/Reading(ppm)
				No.	Depth (ft)			
1								
2								
3								
4			Light brown and gray loam with gravel, dry					Log from cuttings 0-3.5'
5						D		Odors observed ; 12" recovery ; Headspace = 80 ppm
6								Log from cuttings 5-6.5' Not as damp below 5'
7								
8			Brown coarse sandy clay, some gravel, fine to medium, damp to very damp, very plastic			D		3" Recovery Total Depth = 8.0 ft.
9								
10								
11								
12								
13								
14								
15								

sl - slight	v - very	NO/NS - no odor/ no stain	fm - fine	<input type="checkbox"/> D	SPLIT SPOON SAMPLE
tr - trace	kt - light	HSA - Hollow stem auger	m - medium	<input type="checkbox"/>	CUTTINGS SAMPLE
sm - some	dk - dark	SSA - Solid stem auger	crs - coarse	<input type="checkbox"/> S	SHELBY TUBE SAMPLE
& - and	bf - buff		BH - Bore Hole		
@ - at	brn - brown		SAA - Same As Above		
w - with	blk - black		M.S.L. - Mean Sea Level		
				- - -	EST. WATER TABLE

GEOLOGIC BORING LOG

BORING NO.: SS18-VW	CONTRACTOR: P.S.I.	DATE SPUD: 07/21/93
CLIENT: AFCEE	RIG TYPE: CME 75	DATE CMPL: 07/21/93
JOB NO: DE268.46.04	DRLG METHOD: HSA	ELEVATION:
LOCATION: LITTLE ROCK AFB	BORING DIA: 11 "	TEMP: 95°F
GEOLOGIST: BR VANDERGLAS	DRLG FLUID: NONE	WEATHER: SUNNY, CALM, HUMID
COMMENTS		

Depth (ft.)	Pro-file	USCS	Geologic Description	Samples		Sample Type	Blow Counts	Remarks TIP = Bkgnd/Reading(ppm)
				No.	Depth (ft)			
1			Brown loam with fine to medium gravel, very dry			D	16 25 30	6" Recovery, no odors
2						D	5 4	
3				Dark gray gravelly clay, dry to slightly damp				6
4			Brown to dark gray, fine sandy clay, slightly plastic, moist at 4' bgs	SS18VW	3-4.5	D	2	Strong odors in 1.5' recovery; Headspace =
5		1					120 ppm at 3"	
6		1					1.5' Recovery, stronger odors, very moist	
7			Fine to medium gravelly clay, plastic, not as moist			D	1	Headspace = 120 ppm
8				4	1.5' Recovery, slight to			
9				6	no odor at 7'; Headspace = 145 ppm, not as moist			
10			Mottled gray, brownish red, gravelly clay, some fine to medium gravel			D	2	
11				5				
12				9	No odors			
13						D	9	Headspace = 44 ppm
14								
15								
							5	
							9	No odors
							11	Total depth = 10.5 ft.

sl - slight	v - very	NO/NS - no odor/ no stain	fm - fine	<input type="checkbox"/> D	SPLIT SPOON SAMPLE
tr - trace	kt - light	HSA - Hollow stem auger	m - medium	<input type="checkbox"/>	CUTTINGS SAMPLE
sm - some	dk - dark	SSA - Solid stem auger	crs - coarse	<input type="checkbox"/> S	SHELBY TUBE SAMPLE
& - and	bf - buff		BH - Bore Hole		
@ - at	brn - brown		SAA - Same As Above		
w - with	blk - black		M.S.L. - Mean Sea Level		
				- - -	EST. WATER TABLE

GEOLOGIC BORING LOG

BORING NO.: SS18-VW(2)	CONTRACTOR: P.S.I.	DATE SPUD: 7/22/93
CLIENT: AFCEE	RIG TYPE: CME 75	DATE CMPL: 7/22/93
JOB NO: DE268.46.04	DRLG METHOD: HSA	ELEVATION:
LOCATION: LITTLE ROCK AFB	BORING DIA: 8"	TEMP: 88°F
GEOLOGIST: BR VANDERGLAS	DRLG FLUID: NONE	WEATHER: SUNNY, CALM
COMMENTS		

Depth (ft.)	Pro-file	USCS	Geologic Description	Samples		Sample Type	Blow Counts	Remarks TIP = Bkgnd/Reading(ppm)
				No.	Depth (ft)			
1								
2								
3								
4			Light reddish brown gravelly loam, fine to medium gravel, dry					Log from cuttings 0-3.5'
5			Fragments of shale mixed with unconsolidated material. Reddish brown and gray, gravelly clay, damp	SS18-VW	4-5	D		Slight odors Headspace = 180 ppm
6								
7								
8								
9			Brown gravelly clay, fine to medium gravel, damp to slightly damp					Log from cuttings 5-8.5'
10			Brownish red, gray, and light brown silty clay with some fine pebbles			D		Very slight odors Headspace = 120 ppm Total depth = 10.0 ft.
11								
12								
13								
14								
15								

sl - slight	v - very	NO/NS - no odor/ no stain	fm - fine	<input type="checkbox"/> D	SPLIT SPOON SAMPLE
tr - trace	kt - light	HSA - Hollow stem	m - medium	<input type="checkbox"/>	CUTTINGS SAMPLE
sm - some	dk - dark	auger	crs - coarse	<input type="checkbox"/> S	SHELBY TUBE SAMPLE
& - and	bf - buff	SSA - Solid stem	BH - Bore Hole		
@ - at	brn - brown	auger	SAA - Same As Above		
w - with	blk - black		M.S.L. - Mean Sea Level		
					- - - EST. WATER TABLE

Monitoring Point	Date	Days Elapsed (frac. days)	Time	Hrs elapsed (fractional days)	Respiration Test		Days Elapsed	Elapsed Time (min. x 1000)	O2% CO2%	Hydro-carbon	Helium	Comments	Trend of O2/	New x-values	New k
					Site SS-18	Little Rock AFB, AK									
VW	07/27/93	0.00	07:21	0.00	0.00	20.0	2.5	200	0.25				Time - VW		
VW	07/27/93	0.00	08:21	0.04	0.06	15.5	2.0	760	0.86				17.93076161	0	
VW	07/27/93	0.00	09:22	0.08	0.12	11.8	2.8	1000	1.2				0.262688264	0.42	
VW	07/27/93	0.00	10:20	0.12	0.18	9.0	3.7	1300	1.4						
VW	07/27/93	0.00	11:21	0.17	0.24	6.8	4.1	1600	1.4						
VW	07/27/93	0.00	12:20	0.21	0.30	4.8	4.8	2000	1.6						
VW	07/27/93	0.00	13:17	0.25	0.36	3.0	5.2	2200	1.4						
VW	07/27/93	0.00	14:23	0.29	0.42	2.0	5.7	2500	1.4						
VW	07/27/93	0.00	16:19	0.37	0.54	0.5	6.5	3100	1.4						
MPA-3.5	07/27/93	0.00	07:29	0.00	0.00	20.2	0.7	140	0.17				Trend of O2/	New x-values	New k
MPA-3.5	07/27/93	0.00	08:25	0.04	0.06	17.0	1.3	580	0.62				Time-MPA-3.5	x-values	0.0266
MPA-3.5	07/27/93	0.00	09:26	0.08	0.12	14.5	1.7	660	0.93				16.85266766	0	
MPA-3.5	07/27/93	0.00	10:23	0.12	0.17	11.5	2.5	970	1.0				-2.83495783	0.74	
MPA-3.5	07/27/93	0.00	11:24	0.16	0.24	8.8	3.2	1100	1.0						
MPA-3.5	07/27/93	0.00	12:23	0.20	0.29	6.5	3.8	1400	1.3						
MPA-3.5	07/27/93	0.00	13:21	0.24	0.35	5.5	3.9	1600	1.0						
MPA-3.5	07/27/93	0.00	14:26	0.29	0.42	3.5	4.5	2000	1.2						
MPA-3.5	07/27/93	0.00	16:22	0.37	0.53	2.0	5.0	2000	1.1						
MPA-3.5	07/27/93	0.00	19:45	0.51	0.74	1.5	6.0	2800	1.5						
MPA-3.5	07/28/93	1.00	07:04	-0.02	0.98	4.0	7.5	3500	1.3						
MPA-3.5	07/28/93	1.00	07:10	-0.01	0.99	3.8	7.5	3500	NS	Resample					
MPA-6.5	07/27/93	0.00	07:25	0.00	0.00	20.5	0.7	140	0.13				Trend of O2/	New x-values	New k
MPA-6.5	07/27/93	0.00	08:27	0.04	0.06	14.5	1.3	560	0.65				Time-MPA-6.5	x-values	0.03409
MPA-6.5	07/27/93	0.00	09:29	0.09	0.12	13.5	2.2	960	0.94				17.68782866	0	
MPA-6.5	07/27/93	0.00	10:25	0.13	0.18	10.9	2.8	1100	1.2				-0.72115311	0.54	
MPA-6.5	07/27/93	0.00	11:28	0.17	0.24	8.2	3.5	1600	1.2						
MPA-6.5	07/27/93	0.00	12:25	0.21	0.30	6.5	4.0	1800	1.3						
MPA-6.5	07/27/93	0.00	13:24	0.25	0.36	4.5	4.4	2200	1.2						
MPA-6.5	07/27/93	0.00	14:29	0.29	0.42	3.0	5.0	2600	1.2						
MPA-6.5	07/27/93	0.00	16:25	0.38	0.54	1.5	5.5	3100	1.1						
MPA-6.5	07/27/93	0.00	19:50	0.52	0.75	1.2	6.2	3500	1.5						
MPA-6.5	07/28/93	1.00	07:07	-0.01	0.99	1.42	2.5	4600	1.6						

MPB-4.5	07/27/93	0.00	07:32	0.00	0.00	0.00	0.00	0.00	19.5	0.8	420	0.14	Trend of O2/ Time-MPB-4.5	New x-values	k
MPB-4.5	07/27/93	0.00	08:29	0.04	0.04	0.06	0.06	14.8	1.5	1000	0.51	0.51	15.7770801	0	0.03297
MPB-4.5	07/27/93	0.00	09:31	0.08	0.08	0.12	0.12	10.5	2.2	1200	0.77	0.77	-2.02661026	0.54	
MPB-4.5	07/27/93	0.00	10:28	0.12	0.12	0.18	0.18	8.3	2.7	1500	0.82	0.82			
MPB-4.5	07/27/93	0.00	11:31	0.17	0.17	0.24	0.24	6.0	3.8	2000	0.94	0.94			
MPB-4.5	07/27/93	0.00	12:28	0.21	0.21	0.30	0.30	3.6	4.2	2200	1.1	1.1			
MPB-4.5	07/27/93	0.00	13:26	0.25	0.25	0.35	0.35	4.2	4.2	2400	0.76	0.76			
MPB-4.5	07/27/93	0.00	13:33	0.25	0.25	0.36	0.36	3.0	5.0	3000	0.90	0.90	Resample		
MPB-4.5	07/27/93	0.00	14:31	0.29	0.29	0.42	0.42	2.1	5.1	3000	1.0	1.0			
MPB-4.5	07/27/93	0.00	16:27	0.37	0.37	0.54	0.54	1.5	5.5	3400	0.94	0.94			
MPB-4.5	07/27/93	0.00	19:53	0.51	0.51	0.74	0.74	1.0	6.5	4000	1.3	1.3			
MPB-4.5	07/28/93	1.00	07:14	-0.01	0.99	1.42	1.42	2.0	8.2	4800	1.6	1.6			

Little Rock AFB – Site SS-18
Steady-state Equation – Air Injection

Enter data

Calculated data

$$k = \frac{Q \mu \ln (R_w / R_i)}{H \pi P_{atm} [1 - (P_w / P_{atm})^2]}$$

Where:

Q = Volumetric flow rate of vent well

scfm x (30.48 cm/ft)³ x (1 min/60 s) = cm³/s

μ = Viscosity of Air @ 18° C = g/cm s

P_{atm} = Ambient pressure @ 307 feet of elevation

inches H₂O x (3.61E-2 psia/in. H₂O) = psia

psia x (6.89476E4 g/cm s²)/psia = g/cm s²

R_w = Radius of Vent Well

inches x 2.54 cm/in = cm

H = Depth of Screen (length of screened interval)

feet x 30.48 cm/ft = cm

R_i = Maximum Radius of Venting Influence

feet x 30.48 cm/ft = cm

P_w = Absolute Pressure at Vent Well

inches H₂O x (3.61E-2 psia/in. H₂O) = psia

psia + psia = psia

psia x (6.89476E4 g/cm s²)/psia = g/cm s²

k = cm²

cm² x (1 m/100 cm)² = m²

m² x 1 darcy/(9.870E-13 m²) = darcys

Little Rock AFB

Biodegradation Rate Calculations

enter data

calculated data

Formula: $K_b = K_o \times 1/100\% \times A \times D_o \times C$ Where:

K_b = fuel biodegradation rate

K_o = O_2 utilization rate (%/min.)

A = volume of air/kg soil

D_o = O_2 density = 1340 mg/L

C = Carbon/ O_2 ratio for hexane mineralization = 1/3.5

Test Results:

MPA-5

K_o = max. observed rate

0.0266

%/min.

w = moisture content

18

%

Assume:

Soil properties for mixed grained sand Specify from

Table 1.4 (Ref. Foundation Engineering, Peck, Hanson, and Thornburn, John Wiley Press, 1974)

Porosity:

$n = 0.35$

Unit weight (dry):

$\gamma_d = 1.72$

Void ratio:

$e = n/(1-n) = 0.54$

Specific gravity:

G = 2.65

Calculate A = Air filled volume (V_a)/unit wt.

Solving for 1 liter of soil

a) $V_v = n \times 1 \text{ L}$

$V_v = 0.35$ liters V_v = void volume

b) $S_r = Gw/e$

$S_r = 0.88$ S_r = degree of saturation

c) $V_w = S_r \times V_v$

$V_w = 0.31$ liters V_w = volume of water

d) $V_a = V_v - V_w$

$V_a = 0.04$ liters V_a = volume of air

e) Bulk density = $\gamma_d + (V_w \times \gamma_w) = 2$ kg/l soil

f) $A = V_a/\text{Bulk density} = 0.02$ l air/kg soil

$K_b = K_o \times 1/100\% \times A \times D_o \times C \times 525,600 \text{ min/yr} = 1070$ mg TPH/year

Little Rock AFB

Biodegradation Rate Calculations

enter data

calculated data

Formula: $K_b = K_o \times 1/100\% \times A \times D_o \times C$ Where:

K_b = fuel biodegradation rate

K_o = O_2 utilization rate (%/min.)

A = volume of air/kg soil

D_o = O_2 density = 1340 mg/L

C = Carbon/ O_2 ratio for hexane mineralization = 1/3.5

Test Results:

MPA-5

K_o = max. observed rate

0.03409

%/min.

w = moisture content

18

%

Assume:

Soil properties for mixed grained sand Specify from

Table 1.4 (Ref. Foundation Engineering, Peck, Hanson, and Thornburn, John Wiley Press, 1974)

Porosity:

$n = 0.35$

Unit weight (dry):

$\%d = 1.72$

Void ratio:

$e = n/(1-n) = 0.54$

Specific gravity:

G = 2.65

Calculate A = Air filled volume (V_a)/unit wt.

Solving for 1 liter of soil

a) $V_v = n \times 1 \text{ L}$

$V_v = 0.35$ liters

V_v = void volume

b) $S_r = Gw/e$

$S_r = 0.88$

S_r = degree of saturation

c) $V_w = S_r \times V_v$

$V_w = 0.31$ liters

V_w = volume of water

d) $V_a = V_v - V_w$

$V_a = 0.04$ liters

V_a = volume of air

e) Bulk density = $\%d + (V_w \times \%w) = 2$ kg/l soil

f) $A = V_a/\text{Bulk density} = 0.02$ l air/kg soil

$K_b = K_o \times 1/100\% \times A \times D_o \times C \times 525,600 \text{ min/yr} = 1370$ mg TPH/year

**APPENDIX B
O&M CHECKLIST**

