

LOAN DOCUMENT

PHOTOGRAPH THIS SHEET

①

DTIC ACCESSION NUMBER

LEVEL

LEVEL

INVENTORY

Draft Bioventing Test Work Plan

DOCUMENT IDENTIFICATION

Dec 93

DISTRIBUTION STATEMENT A
Approved for Public Release
Distribution Unlimited

DISTRIBUTION STATEMENT

ACCESSION FOR	
NTIS	GRAM
DTIC	TRAC
UNANNOUNCED	
JUSTIFICATION	
BY	
DISTRIBUTION/	
AVAILABILITY CODES	
DISTRIBUTION	AVAILABILITY AND/OR SPECIAL
A-1	

DISTRIBUTION STAMP

DATE ACCESSIONED

DATE ACCESSIONED

DATE RETURNED

DATE RETURNED

REGISTERED OR CERTIFIED NUMBER

REGISTERED OR CERTIFIED NUMBER

20001127 011

DATE RECEIVED IN DTIC

PHOTOGRAPH THIS SHEET AND RETURN TO DTIC-FDAC

H
A
N
D
L
E

W
I
T
H

C
A
R
E

**DRAFT BIOVENTING TEST WORK PLAN AND
INTERIM TEST RESULTS FOR
FIRE TRAINING PIT 1 (FTA-06) AND
FIRE TRAINING PIT 2 (FTA-07)
K.I. SAWYER AFB, MICHIGAN**

Prepared For

**Air Force Center for Environmental Excellence
Brooks AFB, Texas**

and

**410th Support Group
K.I. Sawyer AFB, Michigan**

ENGINEERING-SCIENCE
ES

DEFENSE TECHNICAL INFORMATION CENTER REQUEST FOR SCIENTIFIC AND TECHNICAL REPORTS

Title
AFCEE Collection

1. Report Availability (Please check one box)

- This report is available. Complete sections 2a - 2f.
- This report is not available. Complete section 3.

2a. Number of Copies Forwarded

1 each

2b. Forwarding Date

July/2000

2c. Distribution Statement (Please check ONE box)

DoD Directive 5230.24, "Distribution Statements on Technical Documents," 18 Mar 87, contains seven distribution statements, as described briefly below. Technical documents MUST be assigned a distribution statement.

- DISTRIBUTION STATEMENT A: Approved for public release. Distribution is unlimited.
- DISTRIBUTION STATEMENT B: Distribution authorized to U.S. Government Agencies only.
- DISTRIBUTION STATEMENT C: Distribution authorized to U.S. Government Agencies and their contractors.
- DISTRIBUTION STATEMENT D: Distribution authorized to U.S. Department of Defense (DoD) and U.S. DoD contractors only.
- DISTRIBUTION STATEMENT E: Distribution authorized to U.S. Department of Defense (DoD) components only.
- DISTRIBUTION STATEMENT F: Further dissemination only as directed by the controlling DoD office indicated below or by higher authority.
- DISTRIBUTION STATEMENT X: Distribution authorized to U.S. Government agencies and private individuals or enterprises eligible to obtain export-controlled technical data in accordance with DoD Directive 5230.25, Withholding of Unclassified Technical Data from Public Disclosure, 6 Nov 84.

2d. Reason For the Above Distribution Statement (in accordance with DoD Directive 5230.24)

2e. Controlling Office

HQ AFCEE

2f. Date of Distribution Statement Determination

15 Nov 2000

3. This report is NOT forwarded for the following reasons. (Please check appropriate box)

- It was previously forwarded to DTIC on (date) and the AD number is
- It will be published at a later date. Enter approximate date if known.
- In accordance with the provisions of DoD Directive 3200.12, the requested document is not supplied because:

Print or Type Name

Laura Peña

Telephone

210-536-1431

Signature

Laura Peña

(For DTIC Use Only)

AC Number

M01-01-0342

PART I

**DRAFT BIOVENTING TEST WORK PLAN FOR
FIRE TRAINING AREA 1 (FTA-06) AND
FIRE TRAINING AREA 2 (FTA-07)
K.I. SAWYER AFB, MICHIGAN**

Prepared For:

**AIR FORCE CENTER FOR ENVIRONMENTAL EXCELLENCE
BROOKS AFB, TEXAS**

And

**410th SUPPORT GROUP
K.I. SAWYER AFB, MICHIGAN**

Prepared By:

**ENGINEERING-SCIENCE, INC.
290 ELWOOD DAVIS ROAD
LIVERPOOL, NEW YORK 13088
(315) 451-9560**

DECEMBER 1993

**DRAFT BIOVENTING TEST WORK PLAN FOR
FIRE TRAINING AREA 1 (FTA-06)
AND
FIRE TRAINING AREA 2 (FTA-07)
K.I. SAWYER AFB, MICHIGAN**

Prepared for

**Air Force Center for Environmental Excellence
Brooks AFB, Texas**

and

**410th Support Group
K.I. Sawyer AFB, Michigan**

by

**Engineering-Science, Inc
290 Elwood Davis Road
Liverpool, New York**

August 1993

TABLE OF CONTENTS

1.0 INTRODUCTION.....	1
2.0 SITE DESCRIPTION.....	2
2.1 Site Location and History.....	2
2.1.1 Fire Training Area 1 (FTA-06).....	2
2.1.2 Fire Training Area 2 (FTA-07).....	2
2.2 Site Geology.....	5
2.3 Site Contaminants.....	5
2.3.1 Contaminants for FTA-06.....	5
2.3.2 Contaminants for FTA-07.....	5
3.0 PILOT TEST ACTIVITIES	8
3.1 Introduction	8
3.2 Well Siting and Construction.....	8
3.2.1 Well Siting and Construction for FTA-06.....	8
3.2.2 Well Siting and Construction for FTA-07.....	10
3.3 Handling of Drill Cuttings.....	10
3.4 Soil and Soil Gas Sampling	10
3.4.1 Soil Sampling	10
3.4.2 Soil Gas Sampling	14
3.5 Blower System	14
3.6 Air Monitoring	14
3.7 In-Situ Respiration Test.....	16
3.8 Air Permeability Test.....	16
3.9 Installation of Extended Pilot Test Bioventing System	16
4.0 EXCEPTIONS TO PROTOCOL PROCEDURES.....	17
5.0 BASE SUPPORT REQUIREMENTS.....	17
6.0 PROJECT SCHEDULE.....	18
7.0 POINTS OF CONTACT	18
8.0 REFERENCES.....	19

LIST OF FIGURES

Figure 2.1 Area Location Map.....	3
Figure 2.2 Site Location Map.....	4
Figure 2.3 Location of Hydrogeologic Cross-Section.....	6
Figure 2.4 Hydrogeologic Cross-Section.....	7
Figure 3.1 Proposed Vent Well/Vapor Monitoring Point Locations at FTA-06.....	9
Figure 3.2 Central Injection Vent Well Construction Detail.....	11
Figure 3.3 Monitoring Point Construction Detail.....	12
Figure 3.4 Proposed Vent Well/Vapor Monitoring Point Locations at FTA-07.....	13
Figure 3.5 Schematic of Blower System.....	15

**DRAFT BIOVENTING TEST WORK PLAN FOR
FIRE TRAINING AREA 1 (FTA-06)
AND
FIRE TRAINING AREA 2 (FTA-07)
K.I. SAWYER AFB, MICHIGAN**

1.0 INTRODUCTION

This test work plan presents the scope of an *in-situ* bioventing pilot test for treatment of fuel contaminated soils within Fire Training Area 1 (FTA-06) and Fire Training Area 2 (FTA-07) on K.I. Sawyer AFB, Michigan. The pilot test has three primary objectives: 1) to assess the potential for supplying oxygen throughout the contaminated soil depth, 2) to determine the rate at which indigenous microorganisms will degrade fuel when stimulated by oxygen rich soil gas, and 3) to evaluate the potential for sustaining these rates of biodegradation until fuel contamination is remediated below regulatory standards.

Pilot testing will consist of two phases; an initial air permeability and *in-situ* respiration test which will take place in September of 1993, and an extended one year pilot test which will be used to determine the potential for bioventing remediation using natural nutrient levels. Testing will also provide an estimate of cold weather biodegradation rates. The initial and extended pilot test will serve as treatability studies under the CERCLA feasibility study process. If bioventing proves to be feasible at this site, pilot test data may be used to design a full scale remediation system and to estimate the time required for site cleanup.

The initial test will involve injection at a vent well with a regenerative blower to produce a radius of influence of approximately 60 feet. *In-situ* rates of fuel biodegradation and soil gas permeability will be determined during this short term test and a decision on how best to proceed with extended testing will be made.

Additional background information on the development and recent success of the bioventing technology is found in the document entitled *Test Plan and Technical Protocol For A Field Treatability Test For Bioventing* (Hinchee, et al. 1992). This protocol document is a supplement to the site-specific work plan, and it will also serve as the primary reference for pilot test vent well designs and detailed test objectives and procedures. Unless otherwise noted, test procedures outlined in the protocol document will be used during the pilot tests at FTA-06 and FTA-07.

2.0 SITE DESCRIPTION

2.1 Site Location and History

K.I. Sawyer AFB is located in the Upper Peninsula of Michigan, approximately 20 miles south of Marquette, Michigan (Figure 2.1). The main base consists of 5,278 acres comprised of runways and airfield operations, industrial operations, housing and recreational facilities, and undeveloped land.

2.1.1 Fire Training Area 1 (FTA-06)

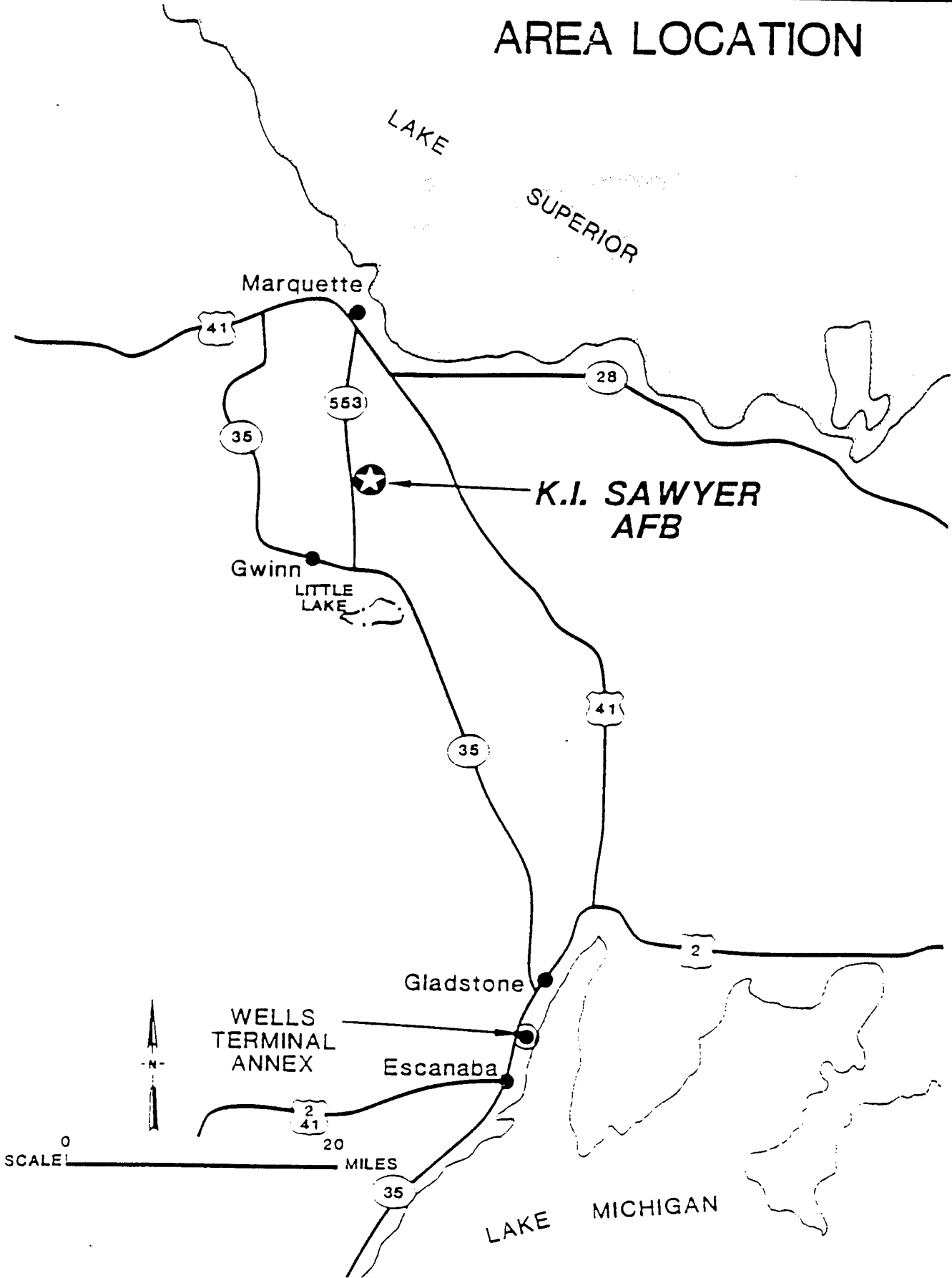
Fire Training Area 1 (FTA-06) is located at the northern end of the base, near the northern end of the taxiway (Figure 2.2). This site was activated in approximately 1958 and was used until the early 1970s. Fuel was stored in 55-gallon drums adjacent to (east of) FTA-06 prior to being emptied onto a soil covered area and ignited for training exercises. Extinguishing agents used were protein foam and carbon dioxide. Fuels included JP-4, AVGAS, and small quantities of hydraulic fluid, oils, and paint thinners-degreasers. Pre-wetting was not practiced routinely at this site. Unburned fuel collection and oil/water separation systems were not installed at the site. Burn frequency average four times per month, with fuel volumes of 300 to 2,000 gallons per training exercise. During the early 1970s fire protection training was moved to Fire Training Area 2 (FTA-07) described in the next section. The site of FTA-06 is level, and is in the clear zone off the north end of the runway.

In May 1993, three soil borings were installed in the FTA-06 source area. Preliminary data from these borings indicates the presence of significant petroleum contamination in the soils above the water table (CH2M Hill, 1993). The hydrocarbon soil contamination at this site is the target for bioventing treatment at this site.

2.1.2 Fire Training Area 2 (FTA-07)

Fire Training Area 2 (FTA-07) is located in the northeast portion of the Base, just east of the taxiway (Figure 2.2). Use of the site for fire training exercises began in the early 1970s. Initially, there was no unburned fuel recovery or prewetting of the site. Training exercises were conducted three to four times per month; during each exercise 300 to 500 gallons of JP-4 were burned. Drums of JP-4 were stored east of and adjacent to the site. Extinguishing agents included protein foam and carbon dioxide. In 1982, a concrete pad was constructed and a fuel-water-drain system installed. Drainage was piped to an oil-water separator. At the completion of each exercise, the liquid remaining on the pad was transferred to the oil-water separator and the fuel phase burned off. The water phase was discharged to a nearby underground leach bed. In 1990, fire training exercises were terminated at the site.

AREA LOCATION



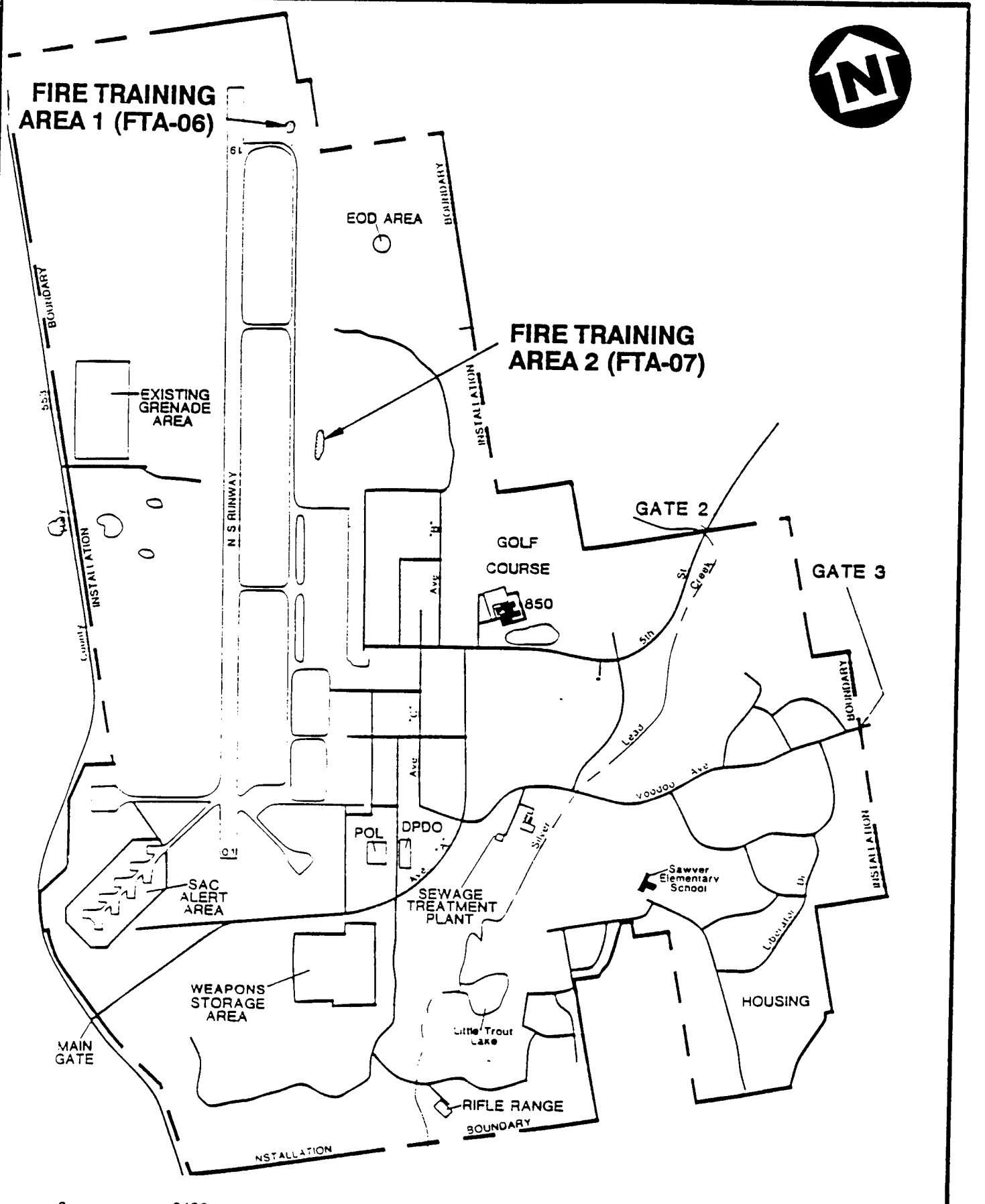
SOURCE: COMMERCIAL MAP

FIGURE 2.2



FIRE TRAINING AREA 1 (FTA-06)

FIRE TRAINING AREA 2 (FTA-07)



0 2400
SCALE FEET

**K.I. SAWYER AFB
FIRE TRAINING AREAS**

SOURCE: INSTALLATION DOCUMENTS

In September 1991, the U.S. Air Force removed underground storage tanks that were adjacent to FTA-07. These tanks had contained various petroleum products. About 500 cubic yards of soil were also excavated. Analyses made with a photoionization detector during the tank and soil removals indicated that contamination in the areas was the result of both the fire training exercises and the leakage of the storage tanks.

In May 1993, three soil borings were installed in the FTA-07 source area. Preliminary data from these borings indicates the presence of petroleum contamination in the soils above the water table (CH2M Hill, 1993). The hydrocarbon soil contamination at this site is the target for bioventing treatment at this site.

2.2 Site Geology

Because the bioventing technology is applied to the unsaturated soils, this section will primarily address soils above the shallow aquifer. Soils above the water table at this site consist largely of sandy loams and sand with some gravel and trace amounts of silt and clay. Bedrock is located at an average depth of 100 to 300 feet below ground surface. Groundwater is encountered at a depth of approximately 70 to 100 feet and flows in a southeasterly direction across the site at a gradient of approximately 0.01 feet per foot (ft/ft). Figures 2.3 and 2.4 illustrate a cross-section at the base. The northern portion of the cross-section runs within approximately 2,400 feet of the pilot test areas.

Due to the relatively homogeneous nature of the fine to coarse-grained sand, the permeability of soils to air flow should remain relatively constant across the site. Effective bioventing on this site is likely. Engineering-Science has completed initial bioventing testing at the K.I. Sawyer fuel storage area and we are confident that oxygen can be distributed at other sites on the base.

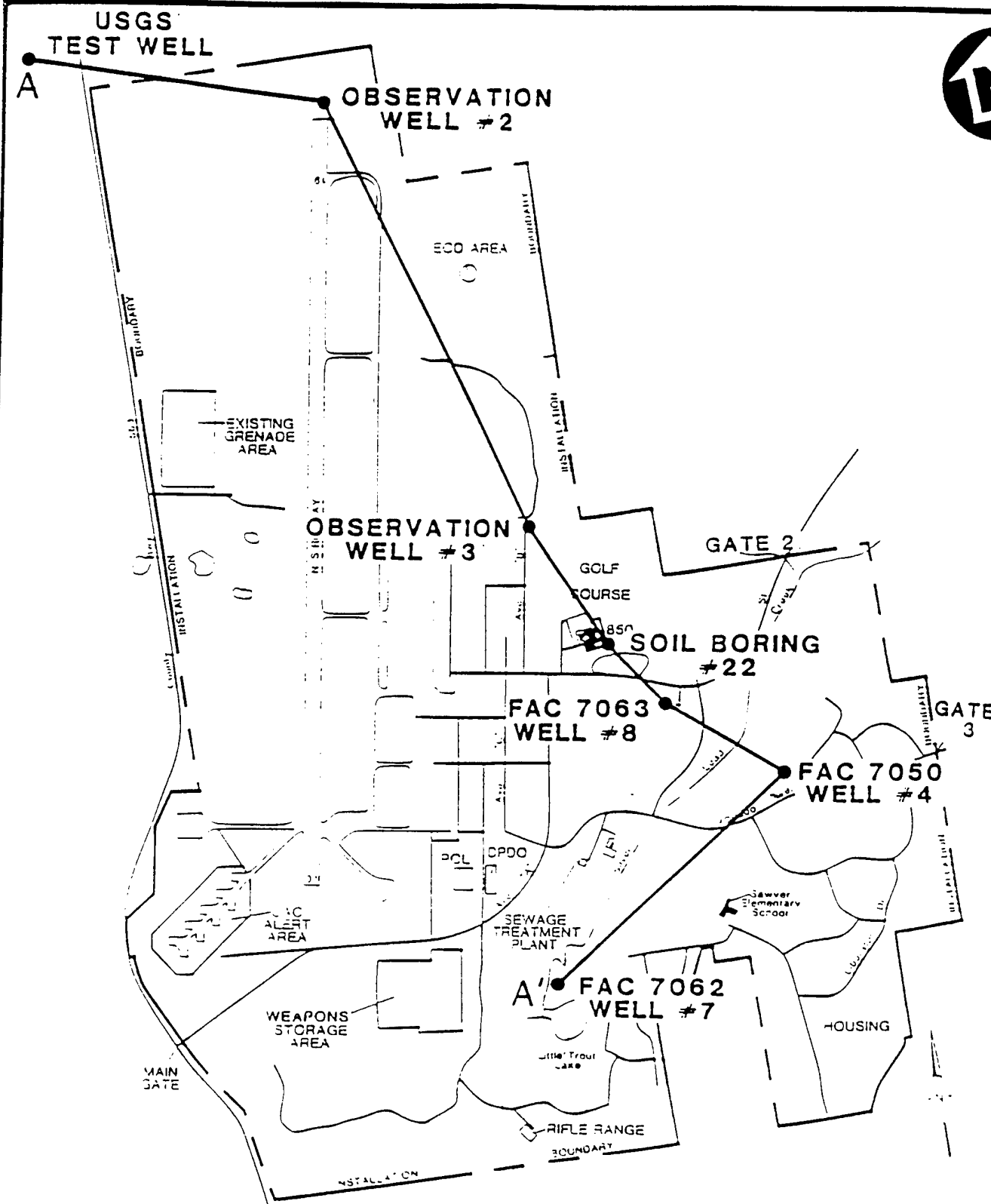
2.3 Site Contaminants

2.3.1 Contaminants for FTA-06

The primary contaminants in the FTA-06 source area are fuel residuals which have migrated to a depth of approximately 70 feet. The maximum depth to groundwater at this site is encountered at approximately 110 feet. Samples collected inside the source area and above the water table showed TPH concentrations from 180 to 14,000 mg/kg. The volatile organic compounds benzene, toluene, ethylbenzene, and total xylenes (BTEX) were detected in the soils above the water table along with trace amounts of chlorinated solvents such as trichloroethene and tetrachloroethene compounds (CH2M Hill, 1993).

2.3.2 Contaminants for FTA-07

The primary contaminants in the FTA-07 source area are fuel residuals which have migrated to a depth of approximately 70 feet where the maximum depth to groundwater is encountered. Samples collected inside the source area and above the water table showed TPH concentrations from nondetect to 4,500 mg/kg. Trace

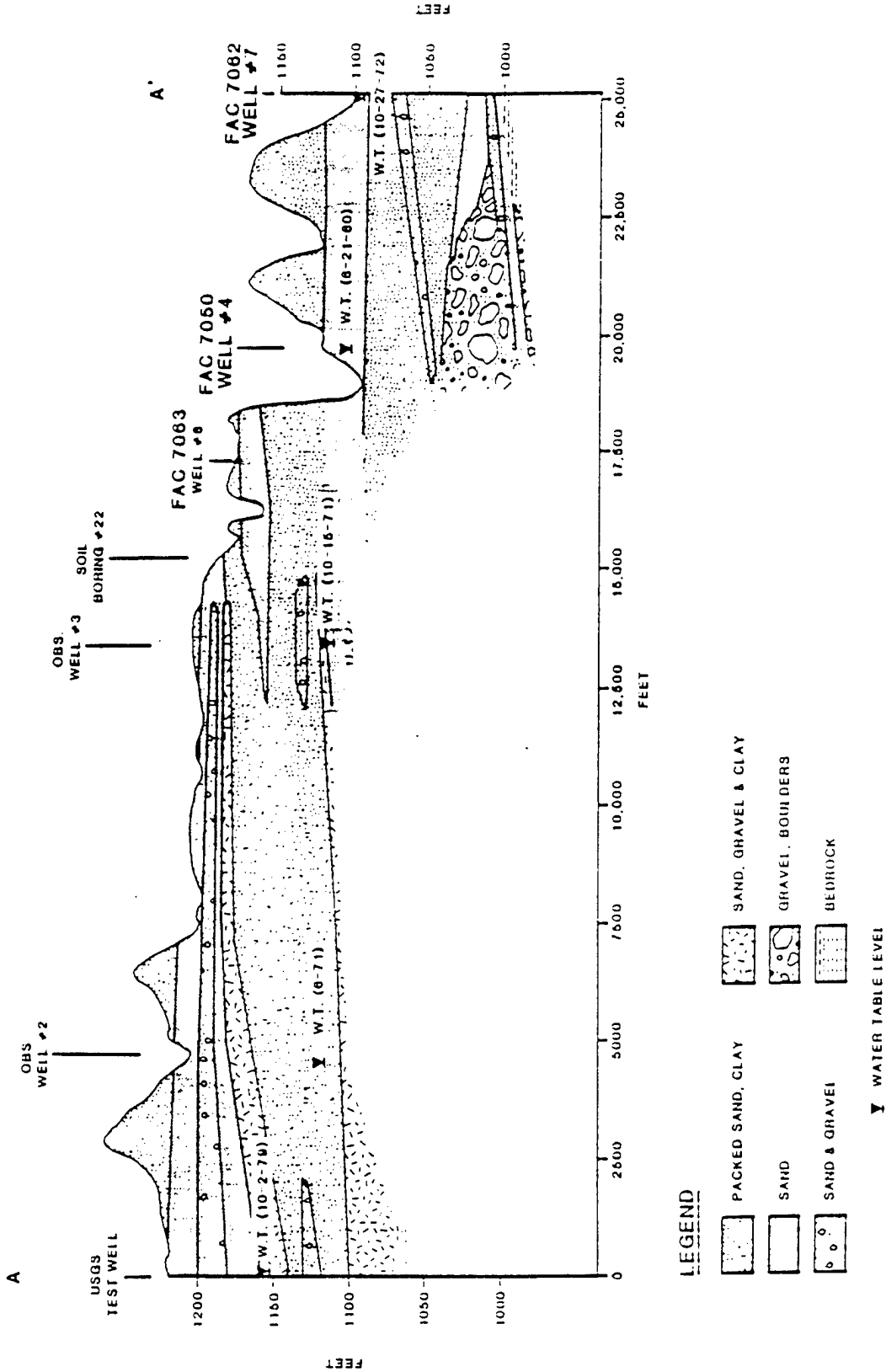


SCALE 0 2400 FEET

K.I. SAWYER AFB
**LOCATION OF
 HYDROGEOLOGIC
 CROSS-SECTION**

SOURCE: INSTALLATION DOCUMENTS

K.I. SAWYER AFB HYDROGEOLOGIC CROSS-SECTION



SOURCE: INSTALLATION DOCUMENTS

amounts of xylenes were also detected in the soils above the water table (CH2M Hill, 1993).

3.0 PILOT TEST ACTIVITIES

3.1 Introduction

The purpose of this section is to describe the work that will be performed by Engineering-Science, Inc. (ES) at FTA-06 and FTA-07. Activities that will be performed at each site include siting and construction of a central vent well (VW) and three vapor monitoring points (VMPs); an *in-situ* respiration test; an air permeability test; and the installation of an extended bioventing pilot test system. Soil and soil gas sampling procedures and blower configuration that will be used to inject air (oxygen) into contaminated soils are also discussed in this section. In an effort to be as cost effective as possible, a single VW will be completed to the depth of lowest seasonal groundwater at each site. Pilot test activities will be confined to unsaturated soils remediation; no dewatering will take place during the pilot tests. Existing monitoring wells will not be used as primary air injection or extraction wells. However, monitoring wells which have a portion of their screened interval above the water table may be used as VMPs or to measure the composition of background soil gas.

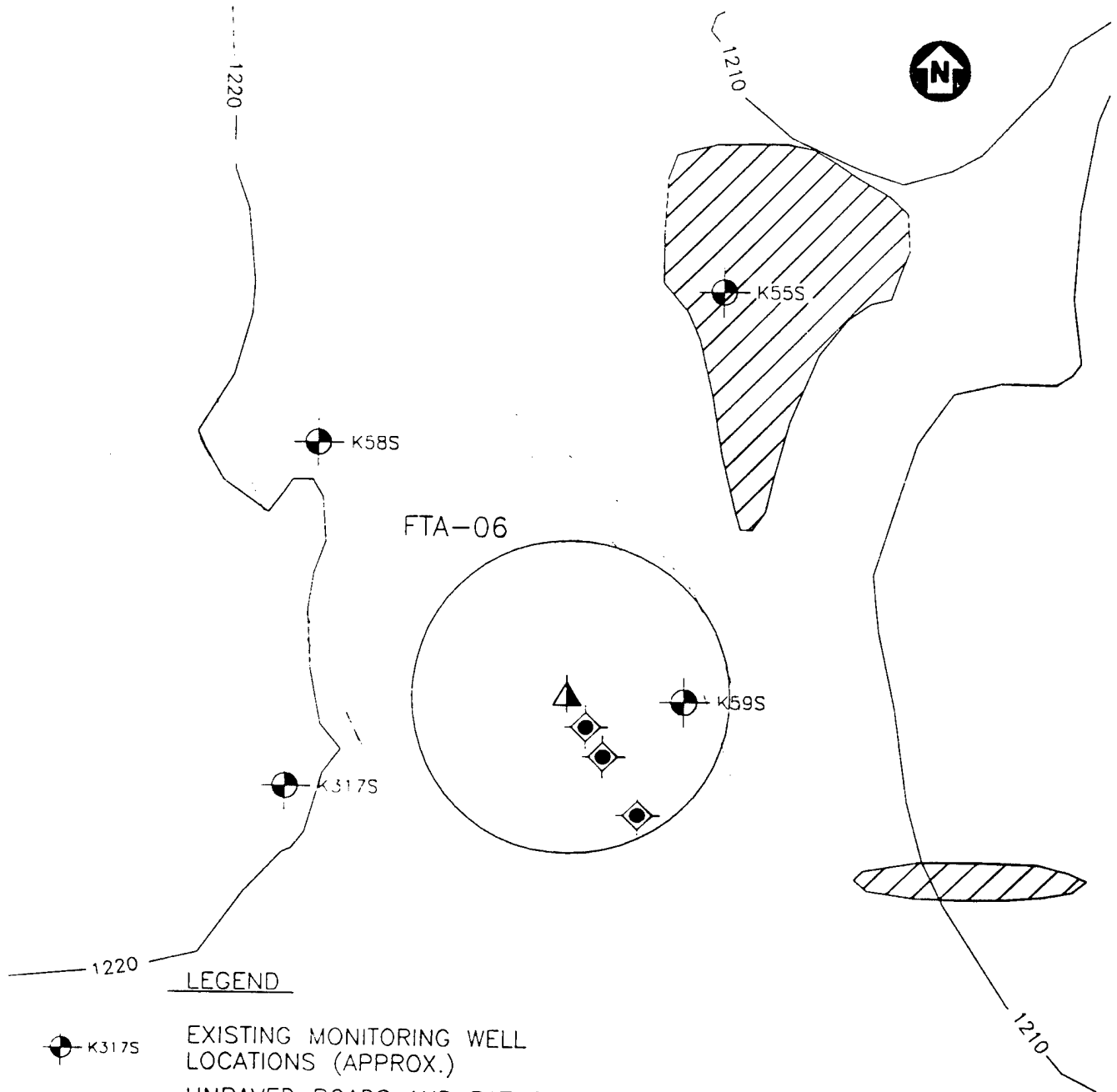
3.2 Well Siting and Construction

3.2.1 Well Siting and Construction for FTA-06







A general description of criteria for siting a single central VW and associated VMPs are included in the protocol document. Figure 3.1 illustrates the proposed location of the central VW and VMPs at FTA-06. The final location of the VW may vary slightly from the proposed location if significant fuel contamination is not observed in the boring for the central VW. Based on site investigation data, the VW will be located just off the center of the fire training area. The area is expected to have an average TPH concentration exceeding 5,000 mg/kg. Soils in this area are expected to be oxygen depleted (< 2%) and increased biological activity should be stimulated by oxygen-rich soil gas ventilation during full-scale operations.

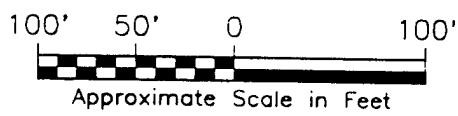
Due to the relatively deep depth of contamination at this site and the potential for moderate permeability soils, the radius of venting influence around the central air injection well in the pit is expected to exceed 60 feet. Three VMPs will be located within a 60-foot radius of the central VW. Background monitoring for this test will be conducted at the background vapor monitoring point installed for the POL Bulk Fuel Storage Area bioventing pilot test conducted in 1992.

The VW will be constructed of 4-inch diameter Schedule 40 PVC, with a 65 foot interval of 0.04 slotted screen set between 10 and 75 feet bgs. Flush-threaded PVC casing and screen will be used with no organic solvents or glues. The filter pack will be clean, well-rounded silica sand with a 6-9 grain size and will be placed in the annular space of the screened interval. A 7-foot layer of bentonite will be placed directly over the filter pack. The bentonite will consist of granular bentonite and/or




LEGEND

-  K317S EXISTING MONITORING WELL LOCATIONS (APPROX.)
-  UNPAVED ROADS AND PATHS
-  10' CONTOURS
-  FENCE LINE
-  VENT WELL
-  VAPOR MONITORING POINT



PROPOSED VENT WELL/
 VAPOR MONITORING POINT
 LOCATIONS FTA-06
 K.I.SAWYER AFB , MICHIGAN

ENGINEERING-SCIENCE
 DESIGN • RESEARCH • PLANNING
 290 ELWOOD DAVIS ROAD • LIVERPOOL, NEW YORK 13088 • 315/461-8600
 OFFICES IN PRINCIPAL CITIES



pellets placed in 6-inch lifts and hydrated in place with potable water to produce an air tight seal above the screened interval. A complete seal is critical to prevent injected air from short-circuiting to the surface during the bioventing test. Silica sand and cement grout will be placed over the pellets and extend to the ground surface. Figure 3.2 illustrates the proposed central VW construction details for this site.

A typical multi-depth VMP installation for this site is shown in Figure 3.3. Soil gas oxygen and carbon dioxide concentrations will be monitored at depth intervals of approximately 15 to 17 feet, 40 to 42 feet, and 70 to 72 feet at each location. Multi-depth monitoring will confirm that the entire soil profile is receiving oxygen and be used to measure fuel biodegradation rates at all depths. The annular space between these three monitoring points will be sealed with bentonite to isolate the monitoring intervals. Additional details on VW and monitoring point construction are found in Section 4 of the protocol document.

3.2.2 Well Siting and Construction for FTA-07

The methods used for well siting and construction for FTA-07 will be identical to those used for FTA-06. Figure 3.4 illustrates the proposed location of the central VW and VMPs at FTA-07.

3.3 Handling of Drill Cuttings

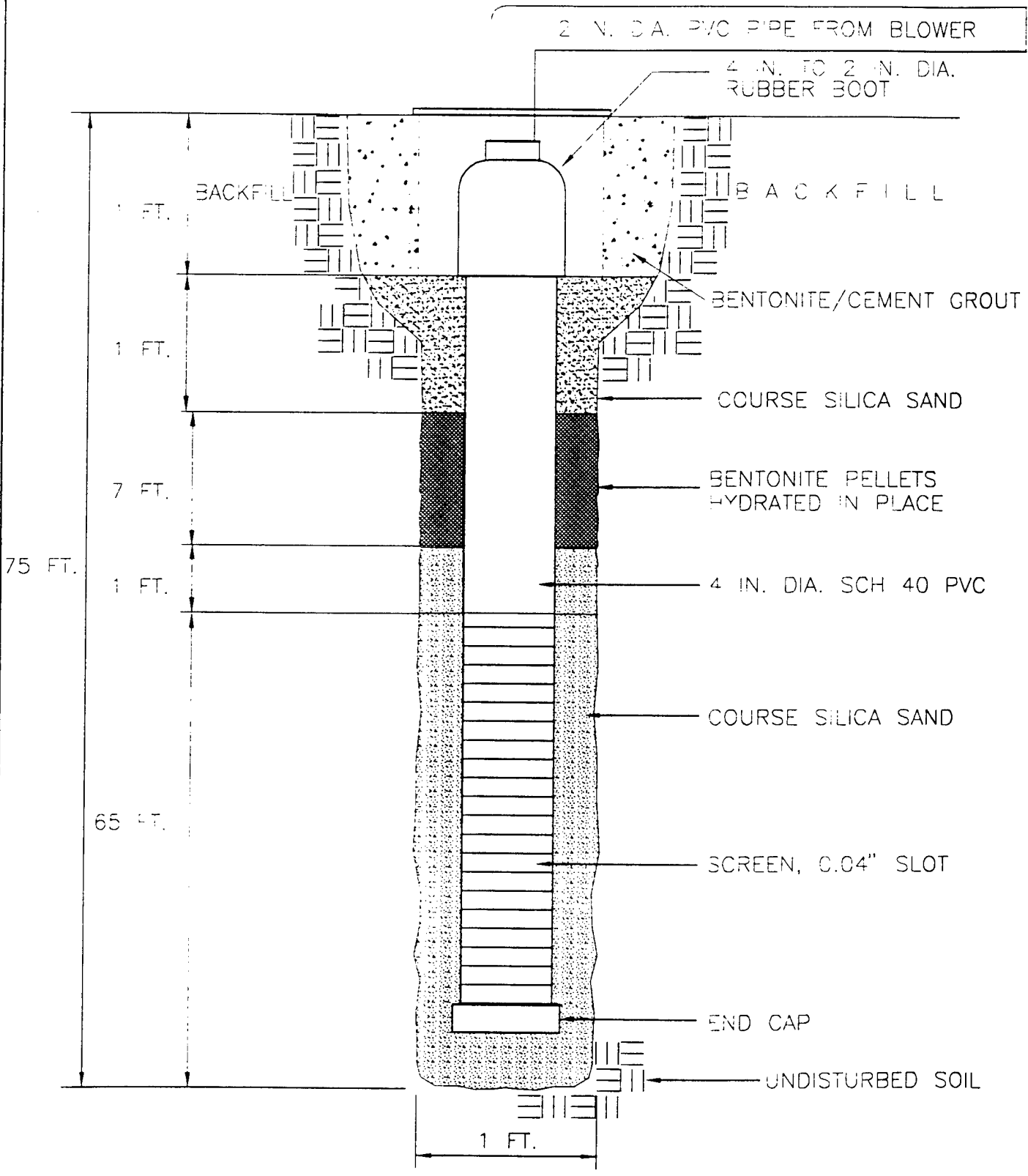
Drill cuttings from all borings will be screened in the field with a total hydrocarbon vapor analyzer (protocol document, Section 4.5.2). Cuttings above nondetect (ND) will be placed on and covered with plastic and left on-site to be transported by the base to the appropriate storage area. Cuttings below ND will be spread on the ground near the soil borings.

3.4 Soil and Soil Gas Sampling

3.4.1 Soil Sampling

Three soil samples will be collected from each pilot test area during the installation of the VWs and VMPs. One sample will be collected from the most contaminated interval of the central VW boring, and one sample will be collected from the interval of highest apparent contamination in each of the borings for two VMPs at each site. Soil samples will be analyzed for TPH, BTEX, soil moisture, pH, particle sizing, alkalinity, total iron and nutrients.

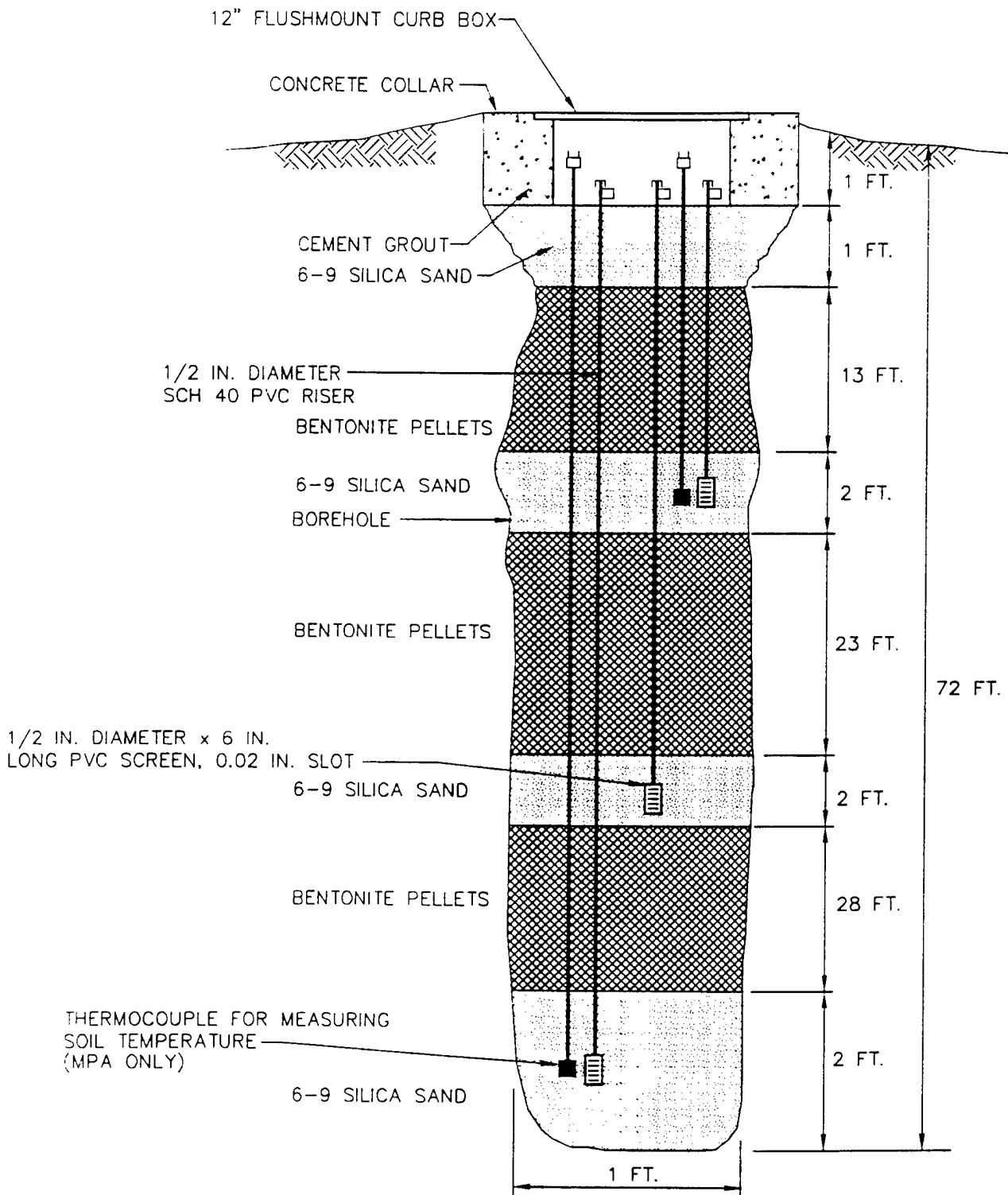
Samples will be collected using a split-spoon sampler containing brass tube liners. A photoionization detector or total hydrocarbon vapor analyzer will be used to insure that breathing zone levels of volatiles do not exceed 1 ppm during drilling and to screen split spoon samples for intervals of high fuel contamination. Soil samples collected in the brass tubes will be immediately trimmed and aluminum foil and a plastic cap placed over the ends. Soil samples will be labelled following the nomenclature specified in the protocol document (Section 5.5), wrapped in plastic, and placed in an ice chest for shipment. A chain of custody form will be filled out and the ice chest shipped to the ES laboratory in Berkeley, California, for analysis.



NOT TO SCALE

FIGURE 3.2
 INJECTION VENTING WELL
 CONSTRUCTION DETAIL
 FTA -06
 K.I. SAWYER AFB, MICHIGAN
 ENGINEERING-SCIENCE, INC.
 Syracuse, N.Y.





NOT TO SCALE

FIGURE 3.3

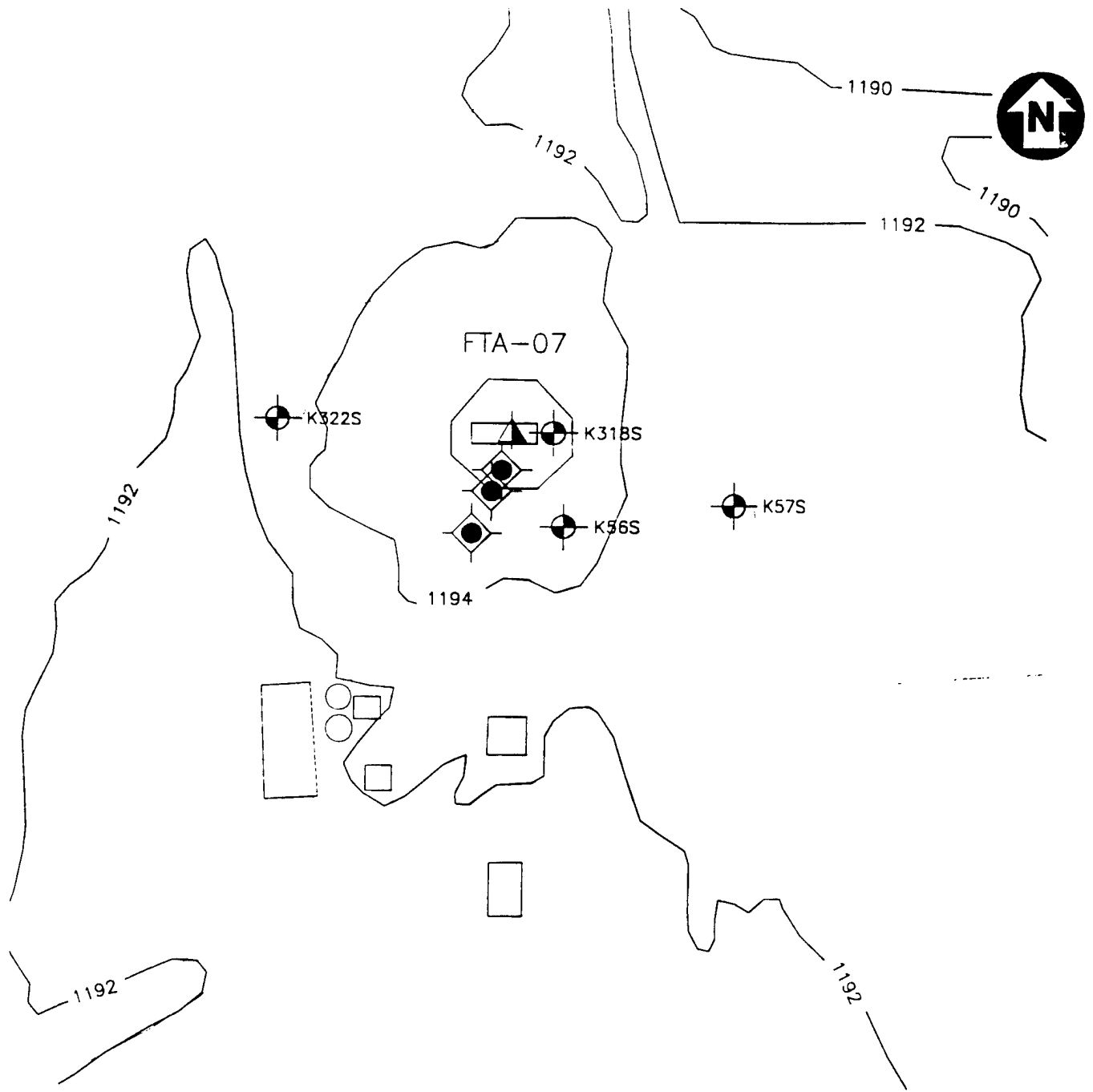
TYPICAL MONITORING POINT
CONSTRUCTION DETAIL

FTA - 06


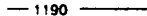


K.I. SAWYER A.F.B., MICHIGAN

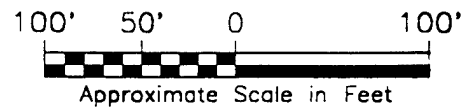
ENGINEERING-SCIENCE, INC.
Syracuse, New York





LEGEND

-  K56S EXISTING MONITORING WELL LOCATIONS (APPROXIMATE)
-  1190 CONTOURS
-  VENT WELL
-  VAPOR MONITORING POINTS



PROPOSED VENT WELL/
VAPOR MONITORING POINT
LOCATIONS FTA-07

K.I. SAWYER AFB, MICHIGAN

ENGINEERING-SCIENCE
DESIGN • RESEARCH • PLANNING

290 ELWOOD DAVIS ROAD • LIVERPOOL, NEW YORK 13088 • 315/461-6680
OFFICES IN PRINCIPAL CITIES



This laboratory has been audited by the U.S. Air Force and meets all quality assurance/quality control and certification requirements for the State of California.

3.4.2 Soil Gas Sampling

A total of six soil gas samples will be collected in SUMMA™ canisters in accordance with the *Bioventing Field Sampling Plan* (ES, 1992). The samples will be collected from the VW in FTA-06, from the VW in FTA-07 and from the VMPs closest to and furthest from the VW at each site. These soil gas samples will be used to predict potential air emissions, to determine the reduction in BTEX and total volatile hydrocarbons (TVH) during the 1-year test, and to detect any migration of these vapors from the source area.

Soil gas sample canisters will be placed in a small cooler and packed with foam pellets to prevent excessive movement during shipment. Samples will not be sent on ice to prevent condensation of hydrocarbons. A chain-of-custody form will be filled out, and the cooler will be shipped to the Air Toxics laboratory in Folsom, California for analysis.

3.5 Blower System

A 2.5-HP regenerative blower capable of injecting 30 - 90 scfm will be used to conduct the initial air permeability test at the two sites. This blower provides a wide range of flow rates and should develop sufficient pressure to move air through moderate permeability soils. Air injection will be used to provide oxygen to soil bacteria and to minimize emissions of volatiles to the atmosphere. If initial testing at either site indicates that less pressure is required to supply oxygen throughout the test volume, a smaller blower will be installed for extended testing.

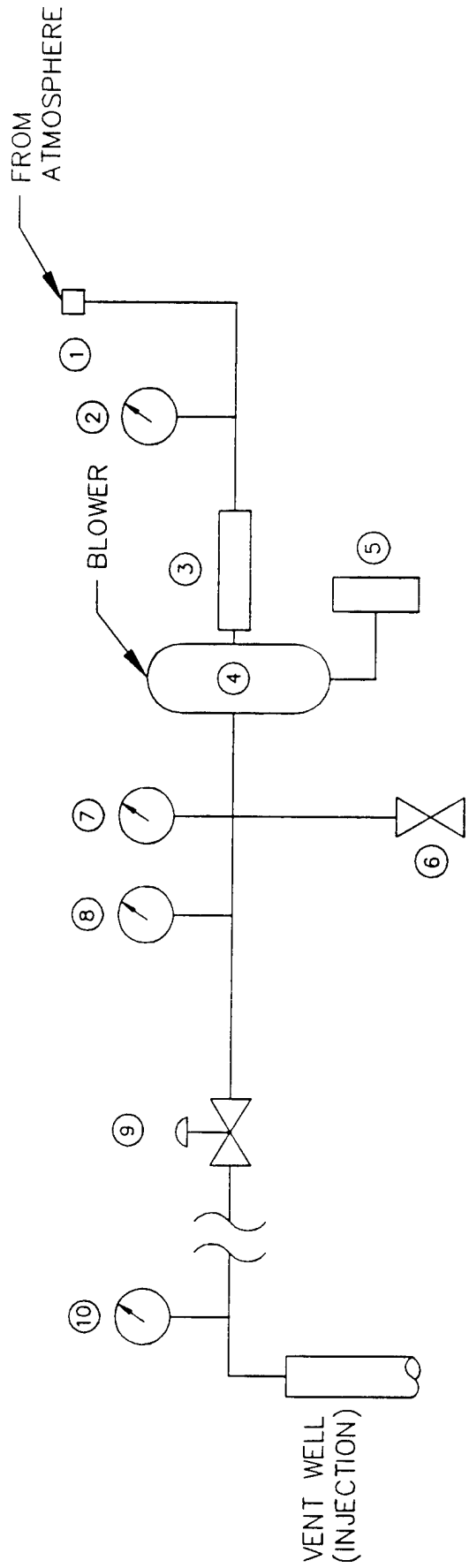
An extended pilot test will be performed if initial pilot testing is positive. The extended bioventing test will be initiated following a review of initial test data and regulatory approval. Figure 3.5 is a schematic of a typical air injection system that will be used for pilot testing at these sites.

The maximum power requirement anticipated for this pilot test is a 230-volt, single-phase, 30-amp service. Additional details on power supply requirements are described in Section 5.0, Base Support Requirements.

3.6 Air Monitoring

The bioventing technique will minimize total emissions of more volatile hydrocarbons to the atmosphere. This is accomplished by reducing air injection rates to supply only the minimum required oxygen to sustain the indigenous microorganisms. By supplying only the required oxygen for biodegradation, volatilization effects caused by excess air injection is minimized.

During all activities involving air injection, the air at the ground surface and at the breathing zone within a 20-foot radius of the injection well will be monitored for volatile hydrocarbons by use of a photoionization detector. Air monitoring will be done to ensure safe working conditions and to provide a rough estimate of volatilization losses, if they occur. More intense air monitoring is required during the



- ① INLET FILTER
- ② VACUUM GAUGE - INCHES OF H2O
- ③ DRIVE MOTOR
2.5 HP / 3450 RPM @ 60 Hz / 230 v / SINGLE PHASE / 15 A /
- ④ BLOWER - GAST R5125
145 SCFM @ 3450 RPM / REGENERATIVE
- ⑤ STARTER
230 v / 27 A / SINGLE PHASE / H1036 HEATER (10.8 A)
- ⑥ AUTOMATIC PRESSURE RELIEF VALVE - SET @ 6 psig
- ⑦ PRESSURE GAUGE (INCHES OF H2O)
- ⑧ THERMOMETER (FAHRENHEIT)
- ⑨ MANUAL PRESSURE RELIEF (BLEED) VALVE - 1 1/2" BALL
- ⑩ AIR VELOCITY MEASUREMENT PORT

SCHEMATIC OF BLOWER
SYSTEM FOR AIR INJECTION
FIRE TRAINING AREAS
K.I. SAWYER AFB, MICHIGAN
ENGINEERING-SCIENCE, INC.
Syracuse, New York



CREATED: 08/2/93

001250D:\0E268\SAWR35.DWG

first eight hours of the air permeability test because the potential for emission of the more volatile hydrocarbons is greatest at that time.

The potential for emissions at both sites is minimal because of the age of the fuel residuals (10 to 20 years). Fire training activities were terminated at FTA-06 in the early 1970s, and downward migration of contaminants at FTA-06 should have been eliminated with the installation of the concrete pad/drainage system in 1982. Flux emissions measured at a similar site at another Air Force base with similar aged contaminants and silty clay soils showed less than 5 grams of fuel hydrocarbons emitted to the atmosphere per hour of operation, or less than 0.26 pounds per day.

3.7 In-Situ Respiration Test

The objective of the *in-situ* respiration test is to determine the rate at which soil bacteria degrade petroleum hydrocarbons. Respiration tests will be performed at the three VMPs with the highest apparent fuel contamination at each site. Air will be injected into each VMP depth interval containing low levels (<2%) of oxygen. A 20 to 24-hour air injection period will be used to oxygenate local contaminated soil. At the end of the air injection period, the air supply will be cut off, and oxygen and carbon dioxide levels will be monitored for five days or until the oxygen level falls below 5 %, whichever is earlier. The decline in oxygen and increase in carbon dioxide concentrations over time will be used to estimate rates of bacterial degradation of fuel residuals.

Concurrent to the air injection period, a helium tracer will also be injected at the VMPs at a concentration of two to five percent. Helium levels will be monitored along with the oxygen and carbon dioxide levels to ensure that the VMPs do not leak. Additional details on the in-situ respiration test are found in Section 5.7 of the protocol document.

3.8 Air Permeability Test

The objective of the air permeability test is to determine the extent of the subsurface that can be oxygenated using one air injection VW. Air will be injected into the 4-inch-diameter VW using the blower unit, and pressure response will be measured at each VMP with differential pressure gauges to determine the region influenced by the unit. Oxygen will also be monitored in the VMPs to verify that oxygen levels in the soil increase as the result of air injection. One air permeability test lasting 4 to 8 hours will be performed.

3.9 Installation of Extended Pilot Test Bioventing System

Extended, 1-year bioventing pilot systems will also be installed at FTA-06 and FTA-07. The base will be requested to provide a power pole with a 230-volt, single-phase, 30-amp breaker box. Two 115-volt receptacles will also be required. Due to the isolated location of FTA-07, AFCEE is willing to assist the base with additional funds to bring power to the site. Depending on the availability of a base electrician, a base electrician or a licensed electrician subcontracted to ES will assist in wiring the blowers to line power. The blower will be housed in a small, prefabricated shed to provide protection from the weather.

The system will be in operation for 24-hours per day for 1 year. After 6 months and 12 months of operation, ES personnel will conduct *in-situ* respiration tests to monitor the long-term performance of this bioventing system. Weekly system checks will be performed by K.I. Sawyer AFB personnel. If required, major maintenance of the blower unit may be performed by ES personnel. Detailed blower system information and a maintenance schedule will be included in the operation and maintenance (O&M) manual provided to the base. More detailed information regarding the test procedures can be found in the protocol document.

4.0 EXCEPTIONS TO PROTOCOL PROCEDURES

The procedures that will be used to measure the air permeability of the soil and *in-situ* respiration rates are described in Sections 4 and 5 of the protocol document. No exceptions to this protocol are anticipated.

5.0 BASE SUPPORT REQUIREMENTS

The following base support is needed prior to the arrival of a driller and the ES test team:

- Confirmation of regulatory approval for the pilot tests.
- Assistance in obtaining a digging permit at each site.
- Provision of any paperwork required to obtain gate passes and security badges for approximately four ES employees and two drillers. Vehicle passes will be needed for two trucks and a drill rig.

During the initial three week pilot test the following base support is needed:

- Twelve square feet of desk space and a telephone in a building located as near to the site as practical.
- The use of a fax machine for transmitting 15 to 20 pages of test results.

Note: A generator supplied by either the base or ES will be used to supply power to the blower during the initial pilot tests.

Prior to and during the one year extended pilot test the following base support is needed:

- A breaker box within 10 feet of the proposed VW which can supply 230-volt, single-phase, 30-amp service for the extended pilot tests.
- Check the blower system at each site at least once a week to ensure that they are operating and to record the air injection pressure. ES will provide a brief training session on this procedure.
- Notify Mr. Richard Moravec or Mr. David Brown, ES-Syracuse, (315) 451-9560; or Mr. Patrick Haas of AFCEE, (210) 536-4331, if the blower or motor stop working.
- Arrange site access for an ES technician to conduct *in-situ* respiration tests approximately six months and one year after the initial pilot test.

6.0 PROJECT SCHEDULE

The following schedule is contingent upon timely approval of this pilot test work plan.

Event	Date
Draft Test Work Plan to AFCEE	13 August 1993
Submit Test Plan for Regulatory Approval	20 August 1993
Regulatory Approval To Proceed	3 September 1993
Begin Pilot Test	6 September 1993
Complete Initial Pilot Test	24 September 1993
Interim Results Report	5 November 1993
Six Month Respiration Test	March 1994
Final Respiration Test	September 1994

7.0 POINTS OF CONTACT

Mr. Mark Hansen
410 CES/CEV
K.I. Sawyer AFB, Michigan 49843-3200
(906) 372-2342

Lt. Colonel Ross Miller/Mr. Patrick Haas
AFCEE/EST
Brooks AFB, Texas 78235-5000
(210) 536-4331

Mr. Richard Moravec/Mr. David Brown
Engineering-Science, Inc
290 Elwood Davis Road, Suite 312
Liverpool, New York 13088
(315) 451-9560 Fax.(315) 451-9570

8.0 REFERENCES

- CH2M Hill, 1993. RI/FS Preliminary Laboratory Data sent to Teresa Buchholz, U.S. Army Corps of Engineers, Omaha, Nebraska. June.
- Engineering-Science, Inc. 1992. *Project Management Plan for AFCEE Bioventing*, Appendix D, Field Sampling Plan. Denver, Colorado. April.
- Hinchee, R.E., S.K. Ong, R.N. Miller, D.C. Downey, R. Frandt. 1992. *Test Plan and Technical Protocol for a Field Treatability Test for Bioventing*. Columbus, Ohio. January.

PART II

**DRAFT INTERIM TEST RESULTS FOR
FIRE TRAINING AREA 1 (FTA-06) AND
FIRE TRAINING AREA 2 (FTA-07)
K.I. SAWYER AFB, MICHIGAN**

Prepared For:

**AIR FORCE CENTER FOR ENVIRONMENTAL EXCELLENCE
BROOKS AFB, TEXAS**

And

**410th SUPPORT GROUP
K.I. SAWYER AFB, MICHIGAN**

Prepared By:

**ENGINEERING-SCIENCE, INC.
290 ELWOOD DAVIS ROAD
LIVERPOOL, NEW YORK 13088
(315) 451-9560**

DECEMBER 1993

TABLE OF CONTENTS

1.0 Pilot Test Design and Construction.....	II-1
1.1 Vent Well Construction	II-1
1.1.1 FTA-06 Vent Well Construction	II-1
1.1.2 FTA-07 Vent Well Construction	II-5
1.2 Soil Vapor Monitoring Points	II-5
1.2.1 FTA-06 Monitoring Points	II-5
1.2.2 FTA-07 Monitoring Points	II-9
1.3 Blower Unit Installation.....	II-9
2.0 Pilot Test Soil and Soil Gas Sampling Results.....	II-9
2.1 Soil and Soil Gas Sampling Results	II-9
2.1.1 FTA-06 Soil and Soil Gas Sampling Results	II-11
2.1.2 FTA-07 Soil and Soil Gas Sampling Results	II-11
2.2 Exceptions to Test Protocol Document Procedures.....	II-11
2.3 Field QA/QC Results.....	II-14
3.0 Pilot Test Results.....	II-14
3.1 Initial Soil Gas Chemistry.....	II-14
3.1.1 FTA-06 Initial Soil Gas Chemistry.....	II-14
3.1.2 FTA-07 Initial Soil Gas Chemistry.....	II-14
3.2 Air Permeability	II-17
3.2.1 FTA-06 Air Permeability	II-17
3.2.2 FTA-07 Air Permeability	II-17
3.3 Oxygen Influence.....	II-20
3.3.1 FTA-06 Oxygen Influence.....	II-20
3.3.2 FTA-07 Oxygen Influence.....	II-20
3.4 In-Situ Respiration Rates.....	II-20
3.4.1 FTA-06 In-Situ Respiration Rates	II-20
3.4.2 FTA-07 In-Situ Respiration Rates	II-27
3.5 Potential Air Emissions.....	II-32
4.0 Recommendations.....	II-32
5.0 References	II-32

LIST OF TABLES

Table 2.1 Soil and Soil Gas Laboratory Analytical Results FTA-06.....	II-12
Table 2.2 Soil and Soil Gas Laboratory Analytical Results FTA-07.....	II-13
Table 3.1 Initial Soil Gas Chemistry FTA-06	II-15
Table 3.2 Initial Soil Gas Chemistry FTA-07	II-16
Table 3.3 Maximum Pressure Response Air Permeability Test FTA-06.....	II-18
Table 3.4 Maximum Pressure Response Air Permeability Test FTA-07.....	II-19
Table 3.5 Influence of Air Injection at Vent Well on Monitoring Point Oxygen Levels FTA-06	II-21
Table 3.6 Influence of Air Injection at Vent Well on Monitoring Point Oxygen Levels FTA-07	II-22
Table 3.7 Oxygen Utilization Rates FTA-06.....	II-26
Table 3.8 Oxygen Utilization Rates FTA-07.....	II-31

LIST OF FIGURES

Figure 1.1 Injection Venting Well Construction Detail	II-2
Figure 1.2 Vent Well/Vapor Monitoring Point Locations FTA-06.....	II-3
Figure 1.3 Geologic Profile Bioventing Site 2 FTA-06	II-4
Figure 1.4 Vent Well/Vapor Monitoring Point Locations FTA-07	II-6
Figure 1.5 Geologic Profile Bioventing Site 3 FTA-07	II-7
Figure 1.6 Typical Monitoring Point Construction Detail FTA-06 and FTA-07.....	II-8

LIST OF FIGURES, CONTINUED

Figure 1.7 Schematic of Blomer System for Air Injection FTA-06 and
FTA-07..... II-10

Figure 3.1 Respiration Test Oxygen and Helium Concentrations Site
FTA-06, MPA-16..... II-23

Figure 3.2 Respiration Test Oxygen and Helium Concentrations Site
FTA-06, MPB-36..... II-24

Figure 3.3 Respiration Test Oxygen and Helium Concentrations Site
FTA-06, MPB-71..... II-25

Figure 3.4 Respiration Test Oxygen and Helium Concentrations Site
FTA-07, MPA-6..... II-28

Figure 3.5 Respiration Test Oxygen and Helium Concentrations Site
FTA-07, MPB-17..... II-29

Figure 3.6 Respiration Test Oxygen and Helium Concentrations Site
FTA-07, MPC-6..... II-30

**DRAFT INTERIM TEST RESULTS REPORT FOR
FIRE TRAINING AREA 1 (FTA-06) AND
FIRE TRAINING AREA 2 (FTA-07)
K.I. SAWYER AFB, MICHIGAN**

The purpose of this report is to describe the results of the initial soil-gas survey and bioventing pilot tests at former fire training areas FTA-06 and FTA-07 at K.I. Sawyer AFB, and to make specific recommendations for extended testing to determine the long-term impact of bioventing to remediate site contaminants. Descriptions of the site history, geology, and contaminants are contained in Part I, the Test Work Plan.

1.0 PILOT TEST DESIGN AND CONSTRUCTION

The areas of contamination at FTA-06 and FTA-07 were defined prior to the pilot testing based on prior activities at these areas and on soil analytical results from prior investigations. Therefore, a soil gas survey was not required to initially determine the locations of the pilot test vent wells and monitoring points within these areas.

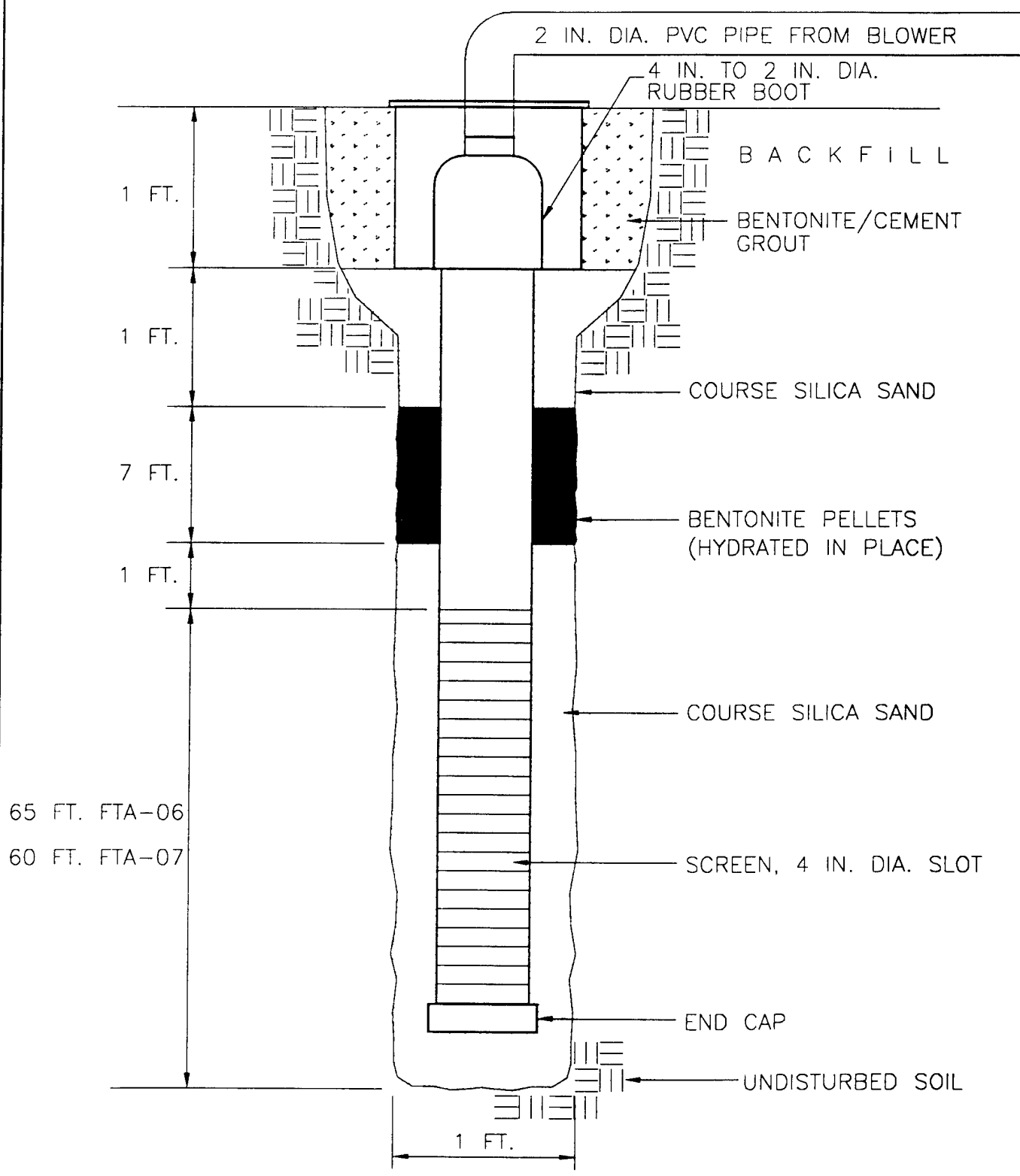
In accordance with the Test Work Plan, the vertical air injection vent wells (VW) and multiple-depth soil-vapor monitoring points (MPs) were installed at FTA-06 the week of September 13, 1993, and at FTA-07 the week of September 20, 1993. A 2.5-horsepower regenerative blower was installed at each VW to provide the necessary air for extended bioventing. Three MPs were installed at each site to monitor the testing. The following sections describe in detail the final design and installation of the bioventing systems.

1.1 Vent Well Construction

The VWs were constructed of 4-inch diameter Schedule 40 PVC with a slot size of 0.04 inches, as shown in Figure 1.1. The annular space between the well casing and the borehole was filled with 6-9 silica sand from the bottom of the boring to approximately 9 feet bgs. Granular bentonite was placed above the sand pack from 9 feet bgs to 2 feet bgs and hydrated in place with potable water. A one-foot layer of sand was placed over the bentonite. The VW was finished with a 1-foot layer of cement and a 12-inch flush-mount protective well cover. The well cover was cemented in place.

1.1.1 FTA-06 Vent Well Construction

The VW at FTA-06 was installed on September 14, 1993 and was located based on soil analytical results from a prior investigation at the site. Elevated hydrocarbon levels were measured in the headspace from soil samples collected during the installation of the vent well at FTA-06, and therefore it was located and constructed as per the Draft Work Plan. Figure 1.2 shows the location of the VW, while Figure 1.3 shows the vertical cross section in the vicinity of FTA-06.

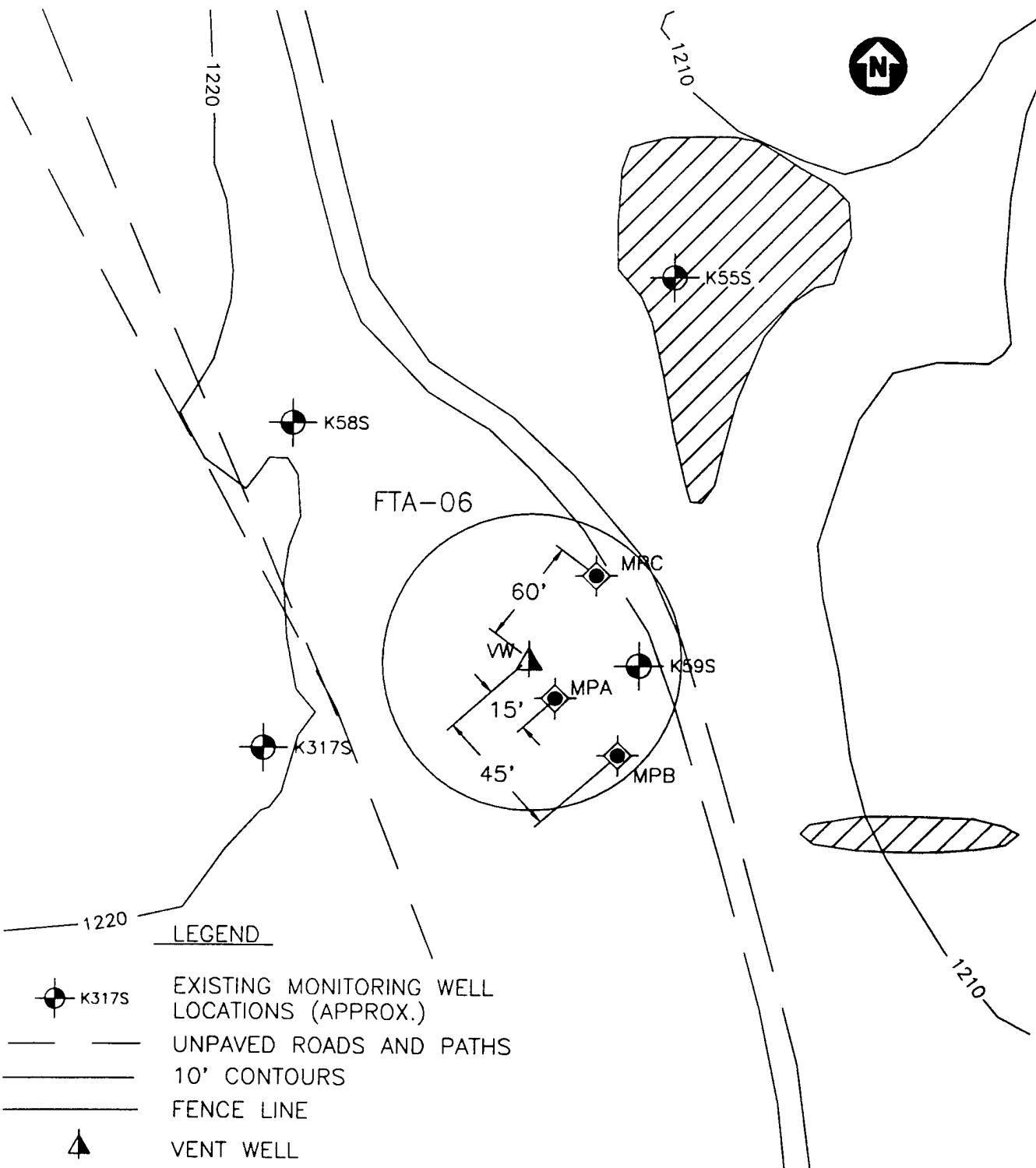


NOT TO SCALE



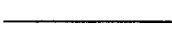



FIGURE 1.1
 INJECTION VENTING WELL
 CONSTRUCTION DETAIL
 FTA-06 & FTA-07
 K.I. SWAYER AFB, MICHIGAN

ENGINEERING-SCIENCE, INC.
 Syracuse, New York

ES



LEGEND

-  K317S EXISTING MONITORING WELL LOCATIONS (APPROX.)
-  UNPAVED ROADS AND PATHS
-  10' CONTOURS
-  FENCE LINE
-  VENT WELL
-  VAPOR MONITORING POINT

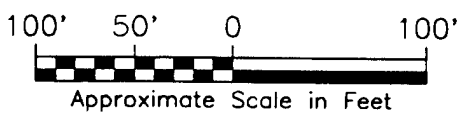
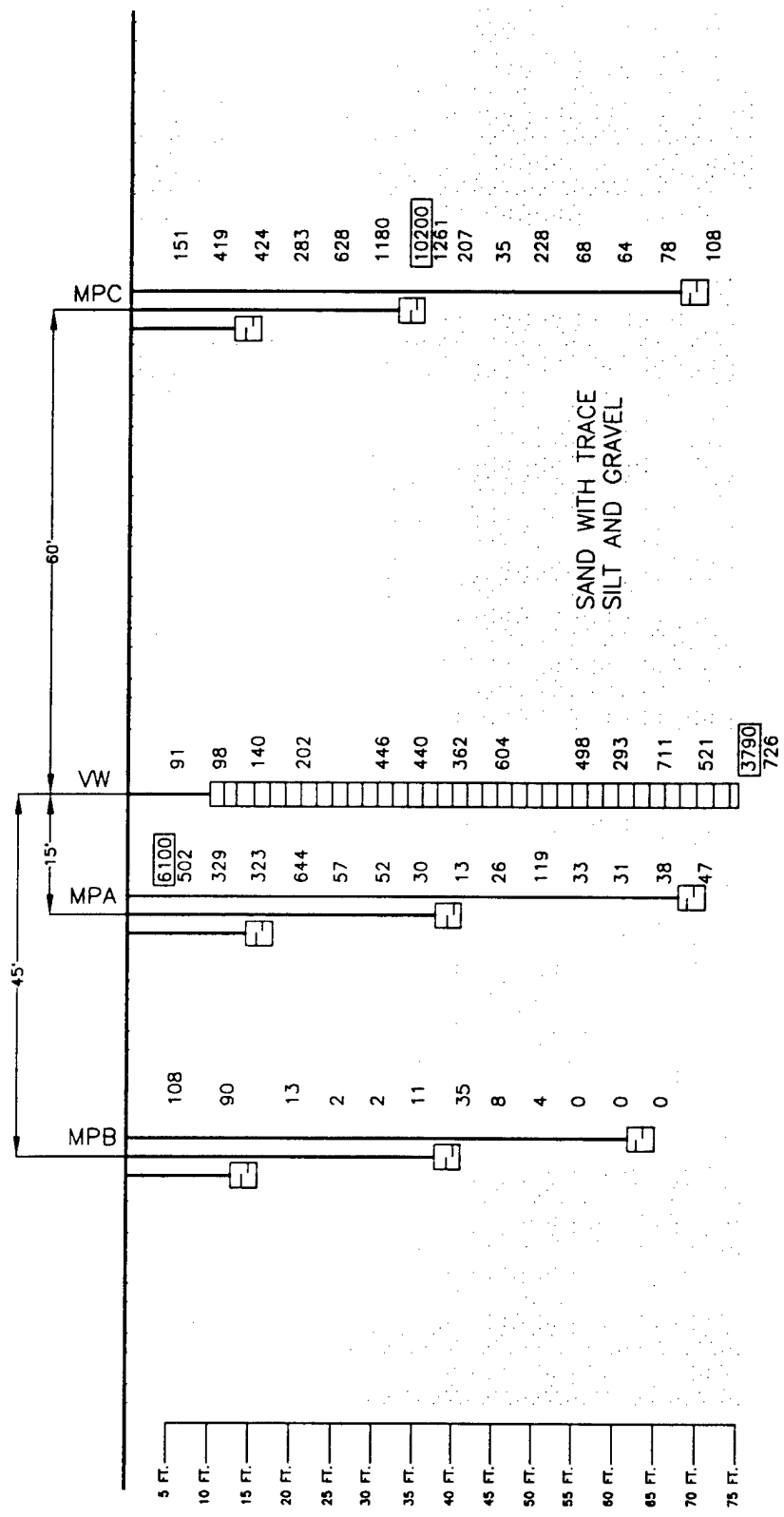


FIGURE 1.2
 VENT WELL/
 VAPOR MONITORING POINT
 LOCATIONS FTA-06
 K.I.SAWYER AFB , MICHIGAN

ENGINEERING-SCIENCE
 DESIGN • RESEARCH • PLANNING

290 ELWOOD DAVIS ROAD • LIVERPOOL, NEW YORK 13088 • 315/451-8580
 OFFICES IN PRINCIPAL CITIES





LEGEND

- MP SCREENED INTERVAL
- AIR INJECTION WELL
- SCREEN INTERVAL
- FIELD SCREENING RESULTS FOR TOTAL VOLATILE HYDROCARBONS (ppmv)
- LABORATORY RESULTS FOR SOIL TOTAL PETROLEUM HYDROCARBONS (PPM)
- VENT WELL
- MONITORING POINT

FIGURE 1.3
GEOLOGIC PROFILE
BIOVENTING SITE 2
FTA-06
 K.I. SAWYER AFB, MICHIGAN
 ENGINEERING-SCIENCE, INC.
 Syracuse, New York



The total depth of the VW was 75 feet below ground surface (bgs), with a screened interval from 10 to 75 feet bgs, as shown in Figure 1.1. Based on hydrocarbon levels measured in the headspace from soil samples collected during the installation of the vent well (Figure 1.3), significant contamination is present down to, and likely below, the 75-foot vent well depth. Contamination may be present down to the level of the groundwater, located at approximately 110 feet below ground surface. However, due to cost restrictions associated with the pilot test, the VW was extended to only 75 feet. It is likely that in this permeable soil the VW provides oxygen to a depth below the 75 foot depth.

1.1.2 FTA-07 Vent Well Construction

The VW at FTA-07 was installed on September 21, 1993. The originally planned VW location was based on soil analytical results from a prior investigation at the site. Test borings for the installation of the VW at FTA-07 were installed initially north (TB-1) and subsequently east (TB-2) of the concrete pad covering the area. However, no evidence of contamination was found in these borings, based on hydrocarbon levels measured at or near zero in the headspace from soil samples collected from these borings. Therefore, the vent well was ultimately installed through the concrete pad covering FTA-07, where elevated hydrocarbon levels were recorded. Figure 1.4 shows the location of the VW, while Figure 1.5 shows the vertical cross section in the vicinity of FTA-07. The total depth of the VW was 70 feet below ground surface (bgs), with a screened interval from 10 to 70 feet bgs, as shown in Figure 1.1. Based on hydrocarbon levels measured in the headspace from soil samples collected during the installation of the vent well (Figure 1.5), minimal contamination is present below the 70-foot vent well depth.

1.2 Soil Vapor Monitoring Points

Each soil vapor monitoring point included three discrete monitoring points, as shown in Figure 1.6. Each discrete monitoring point was constructed of a six-inch long piece of 1/2-inch diameter Schedule 40 PVC well screen with 0.02 slot size. The riser of each discrete point was constructed of 1/2-inch Schedule 80 PVC, which extended to approximately six inches bgs. The top of each discrete point riser was fitted with a 1/2-inch quarter turn ball valve and 3/16-inch hose barb to allow for connection of appropriate monitoring instruments.

Clean 6-9 silica sand was placed around each discrete point to provide a filter pack between the borehole wall and the point. Granular bentonite was placed both below and above each discrete point to provide an air tight seal between the points. The bentonite was placed in 12-inch lifts and hydrated in place to assure the proper seal. The top of each MP was completed with a 12-inch flush mounted protective well cover set in a concrete base.

1.2.1 FTA-06 Monitoring Points

Soil vapor monitoring points were installed at 15, 45, and 60 feet from the VW at FTA-06, as shown in Figures 1.2. The depths for the three discrete sample points at each MP is shown in Figure 1.2. Type K thermocouples with mini-connectors were

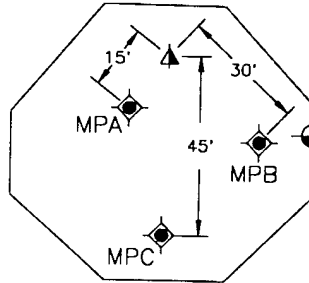


FTA-07

TB-1

1192

K322S



K318S

TB-2

K56S

K57S

1194



LEGEND

- K56S EXISTING MONITORING WELL LOCATIONS (APPROXIMATE)
- UNPAVED ROADS AND PATHS
- 1190 CONTOURS
- VENT WELL
- VAPOR MONITORING POINTS
- TB-1 TEST BORING LOCATION

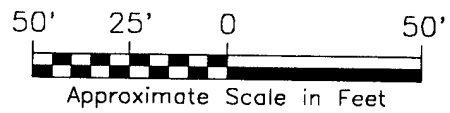


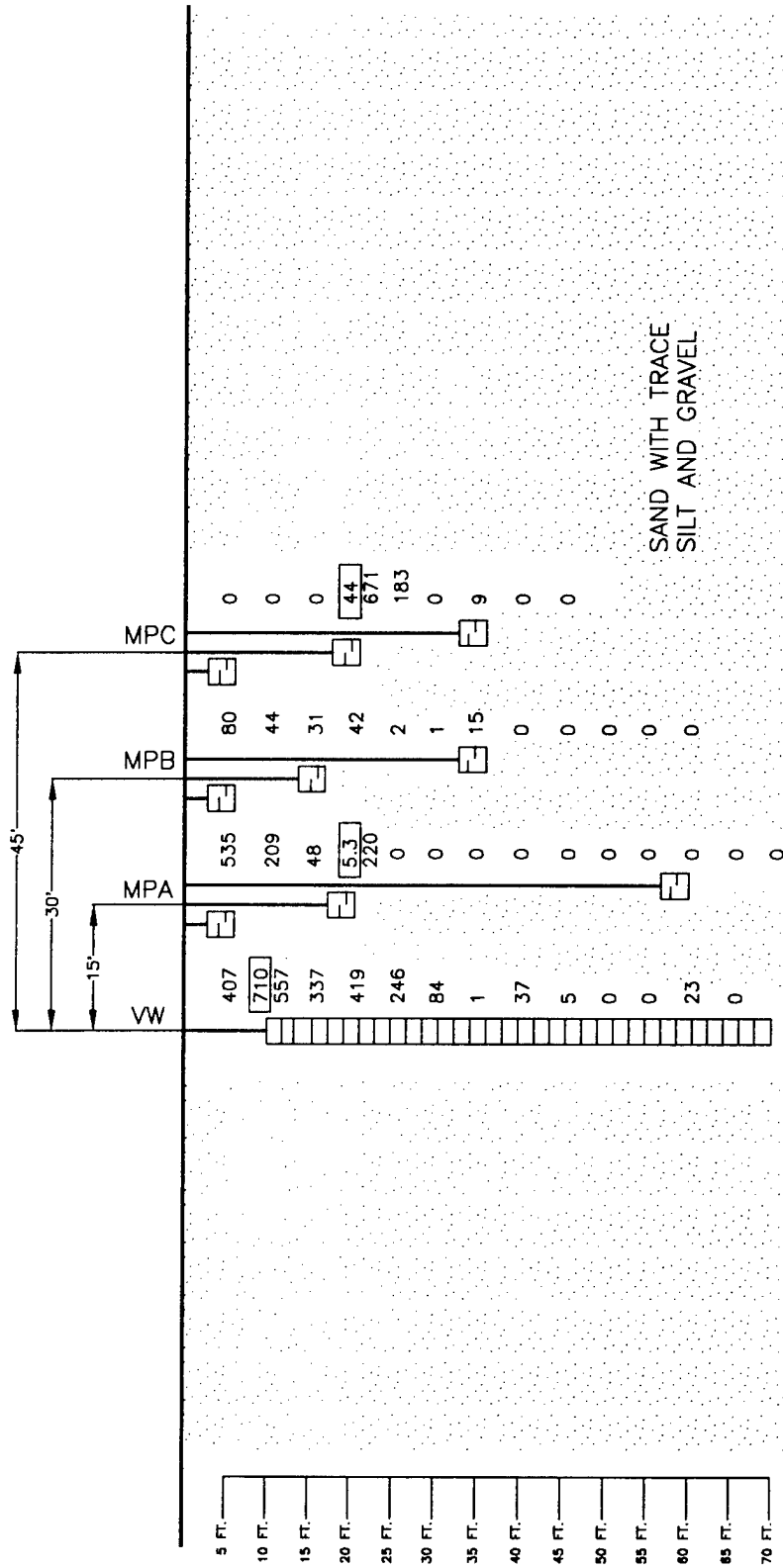
FIGURE 1.4
 VENT WELL/
 VAPOR MONITORING POINT
 LOCATIONS FTA-07

K.I. SAWYER AFB, MICHIGAN

ENGINEERING-SCIENCE
 DESIGN * RESEARCH * PLANNING

290 ELWOOD DAVIS ROAD • LIVERPOOL, NEW YORK 13088 • 315/451-9560
 OFFICES IN PRINCIPAL CITIES





LEGEND

MP SCREENED INTERVAL

AIR INJECTION WELL

SCREEN INTERVAL

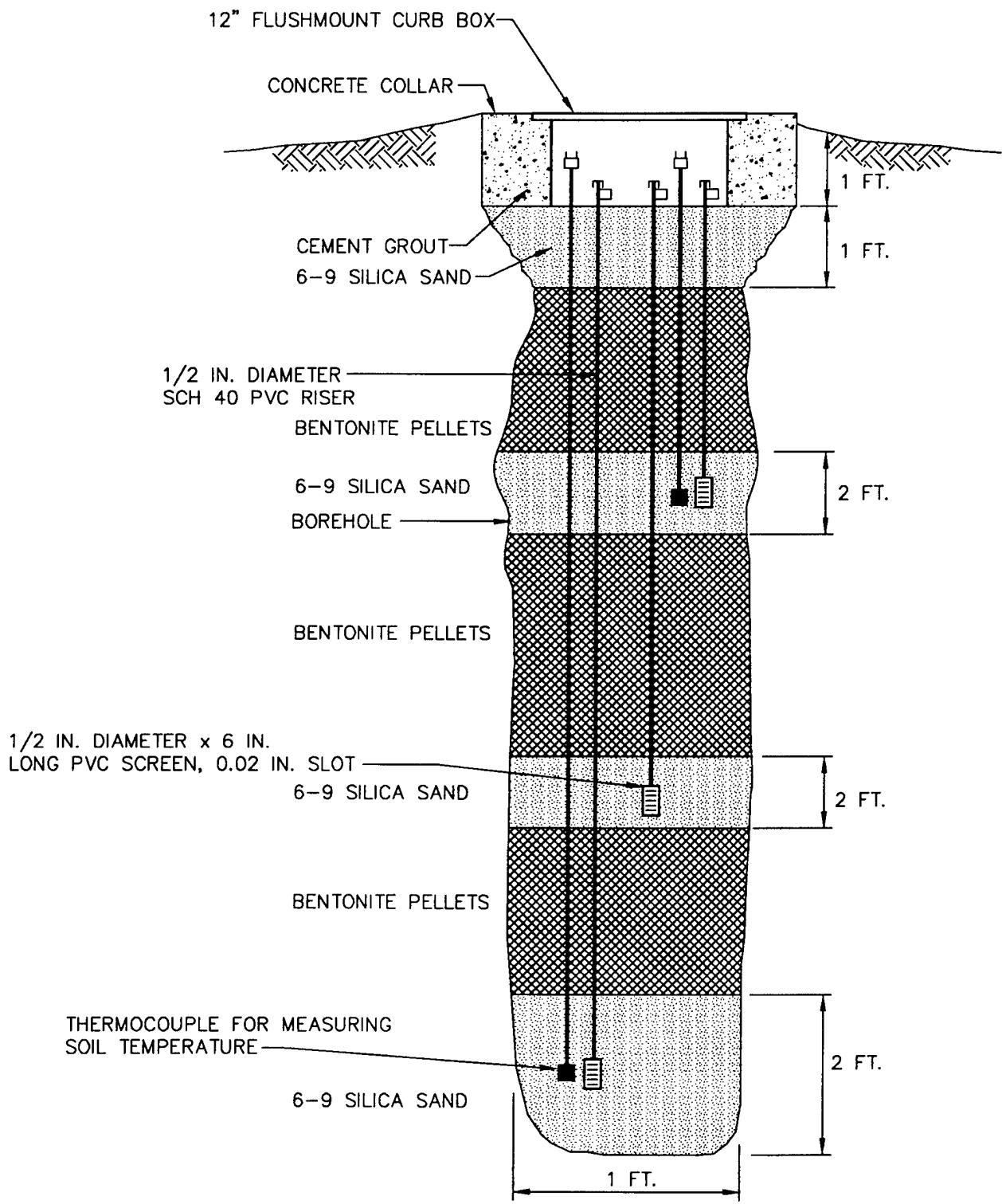
FIELD SCREENING RESULTS FOR TOTAL VOLATILE HYDROCARBONS (ppmv)

LABORATORY RESULTS FOR SOIL TOTAL PETROLEUM HYDROCARBONS (PPM)

VW VENT WELL
MPA MONITORING POINT

FIGURE 1.5
GEOLOGIC PROFILE
BIOVENTING SITE 3
FTA-07

K.I. SAWYER AFB, MICHIGAN
ENGINEERING-SCIENCE, INC.
Syracuse, New York



NOT TO SCALE

NOTE: SEE FIGURE 1.3 AND 1.5 FOR INDIVIDUAL MONITORING POINT DEPTHS.

FIGURE 1.6

TYPICAL MONITORING POINT CONSTRUCTION DETAIL

FTA - 06 AND FTA - 07
K.I. SAWYER A.F.B., MICHIGAN

ENGINEERING-SCIENCE, INC.
Syracuse, New York



installed at MPA-18 and MPA-71. These thermocouples were used to measure the temperature profile at the site.

1.2.2 FTA-07 Monitoring Points

Monitoring points for FTA-07 were located at 15, 30, and 45 feet from the VW, as shown in Figure 1.4. The monitoring points for FTA-07 were closer to the VW than for FTA-06 because the area of contamination was smaller. The depths of the monitoring points was reduced from what was originally planned based on the lack of evidence of contamination at the originally planned depths. The depths for the three discrete sample points at each MP is shown in Figure 1.5. Type K thermocouples with mini-connectors were installed at MPA-6 and MPA-60 at FTA-07. These thermocouples were used to measure the temperature profile at the site.

1.3 Blower Unit Installation

A 2.5-horsepower GAST R5125 regenerative blower unit was installed at each site for the initial and extended pilot tests. The blowers were installed in weather resistant enclosures and electrically wired through a start/stop switch for permanent 230-volt, 15-amp service.

Air from the blower is injected into the vent well via a four-inch PVC line connected to the blower's exhaust port. The amount of air injected into the ground can be controlled by adjusting the manual bleed-valve. A diagram of the blower system is presented in Figure 1.7.

K.I. Sawyer AFB personnel have been briefed on operation and maintenance of the system and have been provided with an O&M checklist and blower maintenance manual.

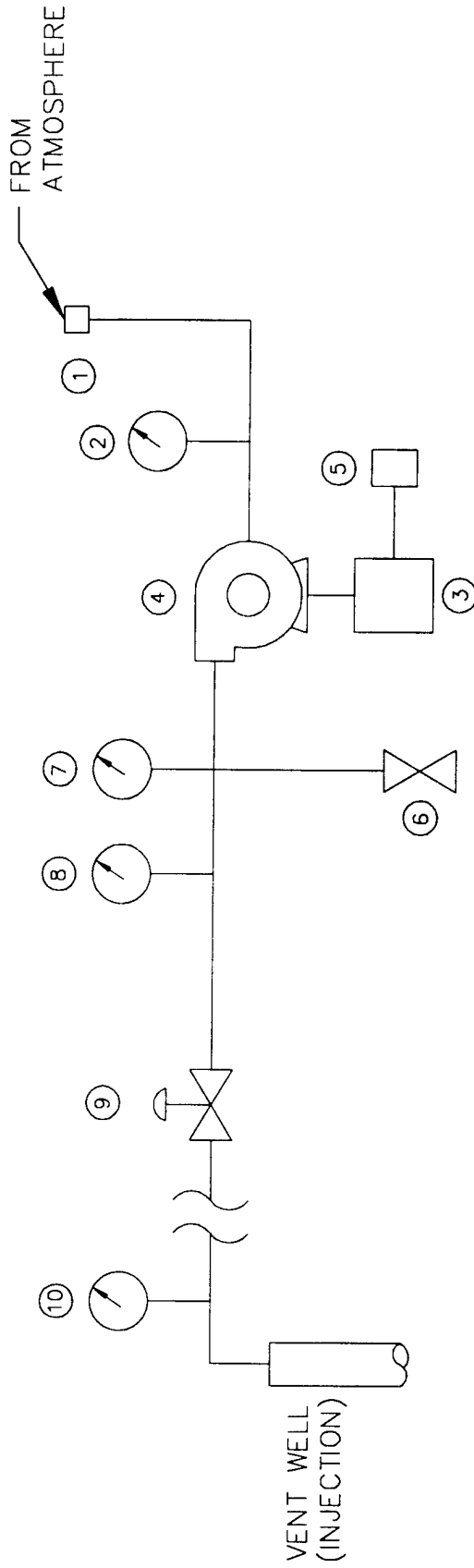
2.0 PILOT TEST SOIL AND SOIL GAS SAMPLING RESULTS

2.1 Soil and Soil Gas Sampling Results

Soils at both FTA-06 and FTA-07 generally consist of coarse to fine brown sands with traces of silt and gravel. This soil profile was consistent throughout the area investigated, down to a depth of approximately 75 feet. No groundwater was encountered in any of the borings.

Hydrocarbon contamination at these sites is due to former fire training exercises, resulting in soil contamination from the ground surface to the maximum depth explored (75 feet bgs). Contaminated soils collected by split spoons during the VW and MP installations were identified based on visual appearance, odor and photoionization detector (PID) screening.

Soil samples were collected for laboratory analysis in stainless steel split spoons during the VW and MP installations. Procedures for soil sample collection specified in the Protocol Document (Hinchee, et. al., 1992) were followed for all sample collections. The soil samples for laboratory analysis were placed on ice and shipped via Federal Express® to the PACE Inc., Laboratory in Novato, CA. Each soil sample was analyzed for total recoverable petroleum hydrocarbons (TRPH); benzene, toluene, ethylbenzene, and xylenes (BTEX); iron; alkalinity; total Kjeldahl



- ① INLET FILTER
- ② VACUUM GAUGE - INCHES OF H2O
- ③ DRIVE MOTOR
2.5 HP / 3450 RPM @ 60 Hz / 230 v / SINGLE PHASE / 15 A /
- ④ BLOWER - GAST R5125
145 SCFM @ 3450 RPM / REGENERATIVE
- ⑤ STARTER
230 v / 27 A / SINGLE PHASE / H1036 HEATER (10.8 A)
- ⑥ AUTOMATIC PRESSURE RELIEF VALVE - SET @ 6 psig
- ⑦ PRESSURE GAUGE (INCHES OF H2O)
- ⑧ THERMOMETER (FAHRENHEIT)
- ⑨ MANUAL PRESSURE RELIEF (BLEED) VALVE - 1 1/2" BALL
- ⑩ AIR VELOCITY MEASUREMENT PORT

FIGURE 1.7
SCHEMATIC OF BLOWER
SYSTEM FOR AIR INJECTION
FTA - 06 AND FTA - 07
K.I. SAWYER AFB, MICHIGAN

ENGINEERING-SCIENCE, INC.
Syracuse, New York



nitrogen (TKN); pH; total phosphorus; percent moisture; and grain-size distribution.

A background sample was also collected and analyzed for (TKN). This sample was collected from near the background boring located near the previously installed POL test site. With a detection limit of 20 mg/kg, TKN was not detected in this background sample.

Soil-gas samples were collected prior to performing the respiration and permeability tests. The samples were collected in laboratory-provided, evacuated Summa® canisters. Procedures for soil-gas sample collection specified in the Protocol Document (Hinchee, et. al., 1992) were followed for all sample collections. Soil gas samples were placed in a shipping box (without ice), and shipped via Federal Express® to Air Toxics, Inc., in Folsom, CA for total volatile hydrocarbon (TVH) and BTEX analysis using EPA Method TO-3.

2.1.1 FTA-06 Soil and Soil Gas Sampling Results

Soil samples were collected for analysis from the 75 to 77 feet interval from the VW, from the 5 to 7 feet interval in MPA, and from the 35 to 37 feet interval in MPC. These were the most heavily contaminated intervals encountered, based on soil sample headspace PID screening results. The results from analysis of the three samples collected are presented in Table 2.1.

Soil gas samples were collected from the VW, MPB-65, and from MPC-71. The results from analysis of the three soil-gas samples collected are presented in Table 2.1.

2.1.2 FTA-07 Soil and Soil Gas Sampling Results

Soil samples were collected for analysis from the 10 to 12 feet interval from the VW, from the 20 to 22 feet interval in MPA, and from the 20 to 2 feet interval in MPB. These were the most heavily contaminated intervals based on soil sample headspace PID screening results. The results from analysis of the three samples collected are presented in Table 2.2.

Soil gas samples were collected from the VW, MPA-6, and from MPC-21. The results from analysis of the three soil-gas samples collected are presented in Table 2.2.

2.2 Exceptions to Test Protocol Document Procedures

Based on hydrocarbon levels measured in the headspace from soil samples collected during the installation of the vent well (Figure 1.3), significant contamination is present down to, and likely below, the 75-foot vent well depth at FTA-06. Contamination may be present down to the level of the groundwater, located at approximately 110 feet below ground surface. However, due to cost restrictions associated with the pilot test, the VW was extended to only 75 feet. It is likely that the VW provides oxygen to a depth below the 75 foot depth of the VW.

No other exceptions to the Test Protocol Document procedures were taken during conduction of the permeability and respiration test.

TABLE 2.1
SOIL AND SOIL GAS LABORATORY ANALYTICAL RESULTS
FTA-06
K.I. Sawyer AFB, Michigan

Analyte (Units) ^a	Sample Location - Depth (feet below ground surface)			
		KIS2-VW	KIS2-MPB-65	KIS2-MPC-71
Soil Gas Hydrocarbons				
TPH (ppmv)		510	1600	1900
Benzene (ppmv)		0.86	9	16
Toluene (ppmv)		1.8	6.7	13
Ethylbenzene (ppmv)		0.19	0.45	0.94
Xylenes (ppmv)		2	1.9	3.9
Soil Hydrocarbons				
	Background	KIS2-VW-75	KIS2-MPA-5	KIS2-MPC-35
TRPH (mg/kg)	NA	3790	6100	10200
Benzene (mg/kg)	NA	ND	ND	1.7
Toluene (mg/kg)	NA	4.2	0.27	18
Ethylbenzene (mg/kg)	NA	4.9	1.4	17
Xylenes (mg/kg)	NA	24	4.4	79
Soil Inorganics				
Iron (mg/kg)	NA	2510	2430	3770
Alkalinity (mg/kg as CaCO ₃)	NA	190	ND	ND
pH (units)	NA	8.4	5.7	5.1
TKN (mg/kg)	ND (<20)	ND	51	65
Phosphorus (mg/kg)	NA	100	77	100
Soil Physical Parameters				
Soil Temp. (°F 6' & 60')	NA	55.5 & 45.5	NS	NS
Moisture (% wt.)	NA	3.4	4.4	9.6
Gravel (%)	NA	1.5	2.2	1
Sand (%)	NA	78.3	95.8	91
Silt (%)	NA	18.5	0.3	6.4
Clay (%)	NA	1.7	1.7	1.7

^aTRPH = total recoverable petroleum hydrocarbons; TPH = total petroleum hydrocarbons; mg/kg = milligrams per kilogram; ppmv = parts per million by volume; CaCO₃ = calcium carbonate; TKN = total kjeldahl nitrogen.
 ND - Not detected
 NS - Not sampled
 NA - Not analyzed

TABLE 2.2
SOIL AND SOIL GAS LABORATORY ANALYTICAL RESULTS
FTA-07
K.I. Sawyer AFB, Michigan

Analyte (Units) ^a	Sample Location – Depth (feet below ground surface)			
		KIS3-VW	KIS3-MPA-6	KIS3-MPC-21 & DUP
Soil Gas Hydrocarbons				
TPH (ppmv)		12	110	2400/2300
Benzene (ppmv)		ND	ND	9.4/9.1
Toluene (ppmv)		0.035	ND	19/18
Ethylbenzene (ppmv)		0.008	0.2	1.1/0.88
Xylenes (ppmv)		0.052	0.21	6.5/6.1
Soil Hydrocarbons				
	Background	KIS3-VW-10	KIS3-MPA-20	KIS3-MPC-20
TRPH (mg/kg)	NA	710	5.3	44
Benzene (mg/kg)	NA	ND	ND	ND
Toluene (mg/kg)	NA	1.4	ND	ND
Ethylbenzene (mg/kg)	NA	5.2	ND	ND
Xylenes (mg/kg)	NA	57	ND	ND
Soil Inorganics				
Iron (mg/kg)	NA	2250	2030	2340
Alkalinity (mg/kg as CaCO ₃)	NA	ND	190	240
pH (units)	NA	7.8	9.4	11
TKN (mg/kg)	ND (<20)	23	ND	ND
Phosphorus (mg/kg)	NA	300	570	470
Soil Physical Parameters				
Soil Temp. (°F 6' & 60')	NA	55.5 & 45.5	NS	NS
Moisture (% wt.)	NA	6.3	4.6	6.1
Gravel (%)	NA	0	0	2
Sand (%)	NA	87.4	95.4	89.8
Silt (%)	NA	11.7	3.7	6.5
Clay (%)	NA	0.9	0.9	1.7

^aTRPH = total recoverable petroleum hydrocarbons; TPH = total petroleum hydrocarbons; mg/kg = milligrams per kilogram; ppmv = parts per million by volume; CaCO₃ = calcium carbonate; TKN = total kjeldahl nitrogen.

ND – Not detected

NS – Not sampled

NA – Not analyzed

2.3 Field QA/QC Results

One field quality assurance/quality control (QA/QC) sample was collected at FTA-07 as part of the five percent collection requirement for QA/QC duplicate samples. The duplicate sample collected was for soil-gas hydrocarbons from KIS3-MPC-21 at FTA-07. The analytical results from the duplicate sample are included in Table 2.2. In general, good repeatability was shown by the duplicate sample.

3.0 PILOT TEST RESULTS

The pilot-test blower systems were installed at FTA-06 and FTA-07 the week of September 27, 1993. Respiration and permeability tests were performed at the two sites the week of September 27 and October 4, 1993. Results from the respiration and permeability tests are provided below.

3.1 Initial Soil Gas Chemistry

Prior to initiating any air injection, soil gas in the VW and all available MPs were monitored for TVH, oxygen, and carbon dioxide at FTA-06 and FTA-07. The VW and MPs were purged prior to monitoring. Soil gas monitoring was accomplished using portable gas analyzers as described in the Protocol Document (Hinchee et al., 1992).

3.1.1 FTA-06 Initial Soil Gas Chemistry

The results of the initial monitoring at FTA-06 are presented in Table 3.1. As shown in Table 3.1, the VW and all MPs had oxygen levels significantly lower than atmospheric (20.8 %) and carbon dioxide levels significantly higher than atmospheric (0.03 %). TVH readings ranged from 30 ppm to 4,500 ppm. These readings suggest that the indigenous microorganisms are depleting the naturally available oxygen supply and creating carbon dioxide, indicating significant biological activity. Initial soil gas readings taken on subsequent days showed significant differences. This is likely due to atmospheric pressure changes associated with the rapidly changing weather patterns observed at the site, which allow some air exchange between the atmosphere and subsurface soil gasses. This phenomenon was also observed at the POL site at K.I. Sawyer AFB.

3.1.2 FTA-07 Initial Soil Gas Chemistry

The results of the initial monitoring at FTA-07 are presented in Table 3.2. As shown in Table 3.2, all MPs had oxygen levels significantly lower than atmospheric (20.8 %) and carbon dioxide levels significantly higher than atmospheric (0.03 %). TVH readings ranged from 240 ppm to 600 ppm in the MPs. The vent well indicated atmospheric levels of oxygen and carbon dioxide and 0 TVH. This may be due to the fact that a significant portion of the VW is in relatively uncontaminated soil, as shown in Figure 1.5. The MP readings suggest that the indigenous microorganisms are depleting the naturally available oxygen supply and creating carbon dioxide, indicating significant biological activity. As with site FTA-06, initial soil gas readings taken from MPs on subsequent days showed significant differences.

TABLE 3.1
INITIAL SOIL GAS CHEMISTRY
FTA-06
K.I. Sawyer AFB, Michigan

Monitoring Point	Depth (feet)	O ₂ (%)*	CO ₂ (%)*	TVH (ppm)
Vent Well	10 to 75	20.1/5.2	0.7/8.7	200
KIS2-MPA-18	17.5 to 18	18/5.5	2.5/9.5	60
KIS2-MPA-41	40.5 to 41	16/6	2.9/8.5	60
KIS2-MPA-71	70.5 to 71	17.8/7.5	2.1/8	200
KIS2-MPB-16	15.5 to 16	20.8/19	0.7/1.8	30
KIS2-MPB-41	40.5 to 41	6/5.5	9.2/9.5	60
KIS2-MPB-65	64.5 to 65	1/0.5	12.2/13	1600
KIS2-MPC-16	15.5 to 16	12.5/20.5	5/1	2600
KIS2-MPC-36	35.5 to 36	21/18	0/2.1	160
KIS2-MPC-71	70.5 to 71	3/16	11/4	4500

* Duplicate readings were taken on two subsequent days.

TABLE 3.2
INITIAL SOIL GAS CHEMISTRY
FTA-07
K.I. Sawyer AFB, Michigan

Monitoring Point	Depth (feet)	O ₂ (%)*	CO ₂ (%)*	TVH (ppm)
Vent Well	10 to 70	20.5	0.25	0
KIS3-MPA-6	5.5 to 6	6/10.5	8/5.2	600
KIS3-MPA-20	20 to 20.5	16/14.3	3.5/2	240
KIS3-MPA-60	59.5 to 60	18.3/13	1.3/2.4	390
KIS3-MPB-6	5.5 to 6	6/9	9.5/6.6	460
KIS3-MPB-17	16.5 to 17	8.5/10.4	7.5/5.5	380
KIS3-MPB-36	35.5 to 36	8/10	8/5.3	440
KIS3-MPC-16	5.5 to 6	8.5/7	8.3/8.5	310
KIS3-MPC-36	20.5 to 21	17/14	2.9/4.2	600
KIS3-MPC-71	35.5 to 36	20/17	0.3/0.8	100

* Duplicate readings were taken on two subsequent days.

3.2 Air Permeability

3.2.1 FTA-06 Air Permeability

An air permeability test was conducted at FTA-06 on September 29, 1993. Air was injected into the VW for 40 minutes at a rate of approximately 150 cubic feet per minute (cfm) and a measured inlet pressure of less than one inch of water. Air pressure was measured with respect to time at MPA-18, MPA-41, MPA-71, MPB-16, MPB-41, and MPB-71. Steady state pressures were obtained within 35 minutes at all six monitored points. Table 3.3 provides maximum steady-state pressures at each of these points.

A second air permeability test was conducted at FTA-06 on September 29, 1993. Air was injected into the VW for 130 minutes at a rate of approximately 150 cfm and a measured inlet pressure of less than one inch of water. Air pressure was measured with respect to time at MPC-16, MPC-36, and MPC-71. Steady state pressures were obtained within 56 minutes at all three monitored points. Table 3.3 provides maximum steady-state pressures at each of these points.

Using the HyperVentilate® computer model and the data from the permeability tests, air permeability values were computed. Due to the gradual response and relatively long time required to reach steady state, the dynamic method of determining soil permeability was used (Hinchee et al., 1992). Using the HyperVentilate® model, computed air permeability values ranged from 25.7 to 186.3 darcys, with an average value of 111 darcys, typical values for coarse sands.

3.2.2 FTA-07 Air Permeability

An air permeability test was conducted at FTA-07 on October 1, 1993. Air was injected into the VW for 1425 minutes at a rate of approximately 150 cubic feet per minute (cfm) and a measured inlet pressure of 4 inches of water. Air pressure was measured with respect to time at MPC-6, MPC-21, and MPC-36. Steady state pressures were obtained within 75 minutes at all three monitored points. Table 3.4 provides maximum steady-state pressures at each of these points.

A second air permeability test was conducted at FTA-07 on October 2, 1993. Air was injected into the VW for 123 minutes at a rate of approximately 150 cfm and a measured inlet pressure of less than one inch of water. Air pressure was measured with respect to time at MPA-6, MPA-20, MPA-60, MPB-6, MPB-17, and MPB-36. Steady state pressures were obtained within 123 minutes at all six monitored points. Table 3.4 provides maximum steady-state pressures at each of these points.

Using computer modeling and the data from the permeability tests, air permeability values were computed. Due to the gradual response and relatively long time required to reach steady state, the dynamic method of determining soil permeability was used (Hinchee et al., 1992). Using the HyperVentilate® model, computed air permeability values ranged from 20.3 to 191.5 darcys, with an average value of 108.1 darcys.

TABLE 3.3
MAXIMUM PRESSURE RESPONSE
AIR PERMEABILITY TEST
FTA-06
K.I. Sawyer AFB, Michigan

Dist. from VW (feet) Monitoring Point	15			45			60		
	MPA			MPB			MPC		
Depth (feet)	18	41	71	16	41	65	16	36	71
Time (minutes)	35	35	25	35	35	15	56	56	56
Max. Pressure (inches of water)	0.95	1.15	1.10	0.78	0.80	0.69	0.48	0.44	0.43

Inlet conditions at the VW were 150 cfm at < 1" water.

TABLE 3.4
MAXIMUM PRESSURE RESPONSE
AIR PERMEABILITY TEST
FTA-07
K.I. Sawyer AFB, Michigan

Dist. from VW (feet)	15			30			45		
Monitoring Point	MPA			MPB			MPC		
Depth (feet)	6	20	60	6	17	36	6	21	36
Time (minutes)	60	123	85	70.5	80.5	123	38	38	75
Max. Pressure (inches of water)	0.93	1.80	2.33	0.56	0.94	1.80	0.60	0.79	0.69

Inlet conditions at the VW were 150 cfm at 4" water.

3.3 Oxygen Influence

The radius of oxygen influence in the subsurface resulting from air injection into the central VW is the primary design parameter for bioventing systems. Optimization of full-scale and multiple VW systems require pilot testing to determine the volume of soil that can be oxygenated at a given flow rate and vent well screen configuration.

3.3.1 FTA-06 Oxygen Influence

Table 3.5 presents the change in soil gas oxygen and carbon dioxide levels that occurred after 130 minutes of air injection at FTA-06. This period of air injection at 150 cfm resulted in a measured increase in soil gas oxygen 15 feet from the vent well. The permeability test was not run until an increase in oxygen was observed at the outer monitoring points. However, the dramatic drop in oxygen at the outer points indicates that oxygen depleted soil gas was being displaced outward from the center of contamination to at least 60 feet, indicating that the vent well will provide oxygen to at least 60 feet. This is supported by the oxygen influence results from FTA-07, as discussed below. The radius of influence will be confirmed during the six-month respiration test.

3.3.2 FTA-07 Oxygen Influence

Table 3.6 presents the change in soil gas oxygen and carbon dioxide levels that occurred after 1485 minutes of air injection at FTA-07. This period of air injection at 150 cfm resulted in a measured increase in soil gas oxygen 60 feet from the vent well. Based on the oxygen increase and the pressure response at the furthest monitoring point (MPC), the long-term radius of oxygen influence will exceed 60 feet when air is injected at 150 cfm.

3.4 In-Situ Respiration Rates

3.4.1 FTA-06 In-Situ Respiration Rates

In-situ respiration tests were performed at FTA-06 at MPA-16, MPB-36, and MPB-71. These points initially all showed depressed oxygen levels, elevated carbon dioxide levels, and high TVH readings, as shown in Table 3.1. A 3 to 4 percent helium in air mixture was injected into each of these points for approximately 20 hours. Oxygen, carbon dioxide, and TVH concentrations were then measured in the soil gas at each of the three discrete monitoring points. These readings were collected periodically for approximately 5 days following cessation of the air injection period. The measured oxygen losses were then used to calculate biological oxygen utilization rates. The results of the in-situ respiration testing at FTA-06 are presented in Figures 3.1 through 3.3. Table 3.7 provides a summary of the oxygen utilization rates.

Helium was used as a conservative, inert tracer gas during the respiration testing. As shown in Figures 3.1 through 3.3, helium levels at all three points dropped significantly throughout the respiration testing. This indicates that some of the oxygen decrease observed may have been due to diffusion.

TABLE 3.5
INFLUENCE OF AIR INJECTION AT VENT WELL
ON MONITORING POINT OXYGEN LEVELS
FTA-06
K.I. Sawyer AFB, Michigan

Dist. from VW (feet)	15			45			60		
Monitoring Point	MPA			MPB			MPC		
Depth (feet)	18	41	71	16	41	65	16	36	71
Initial % Oxygen	5.5	6	7.5	19	5.5	0.5	20.5	18	16
Final % Oxygen*	19	6.5	16	18.2	4.5	0	4	2	0.4
Initial % Carbon Dioxide	9.5	8.5	8	1.8	9.5	13	1	2.1	4
Final % Carbon Dioxide*	3.3	10.9	4.5	3.2	10	14	12	11.8	12.4

* After 130 minutes of air injection at 150 cfm and < 1" water.

TABLE 3.6
INFLUENCE OF AIR INJECTION AT VENT WELL
ON MONITORING POINT OXYGEN LEVELS
FTA-07
K.I. Sawyer AFB, Michigan

Dist. from VW (feet)	15			30			45		
Monitoring Point	MPA			MPB			MPC		
Depth (feet)	6	20	60	6	17	36	6	21	36
Initial % Oxygen	10.5	14.3	13	9	10.4	10	7	14	17
Final % Oxygen*	20.9	20.9	20.9	19.6	20	20.8	8	12	20
Initial % Carbon Dioxide	5.2	2	2.4	6.6	5.5	5.3	8.5	4.2	0.8
Final % Carbon Dioxide*	0.5	0	0	2.6	1.7	0.7	11.7	8.8	1.7

* After 1485 minutes of air injection at 150 cfm and 4" water.

Figure 3.1
 Respiration Test
 Oxygen and Helium Concentrations
 Site FTA-06, MPA-16
 K.I. Sawyer AFB, Michigan

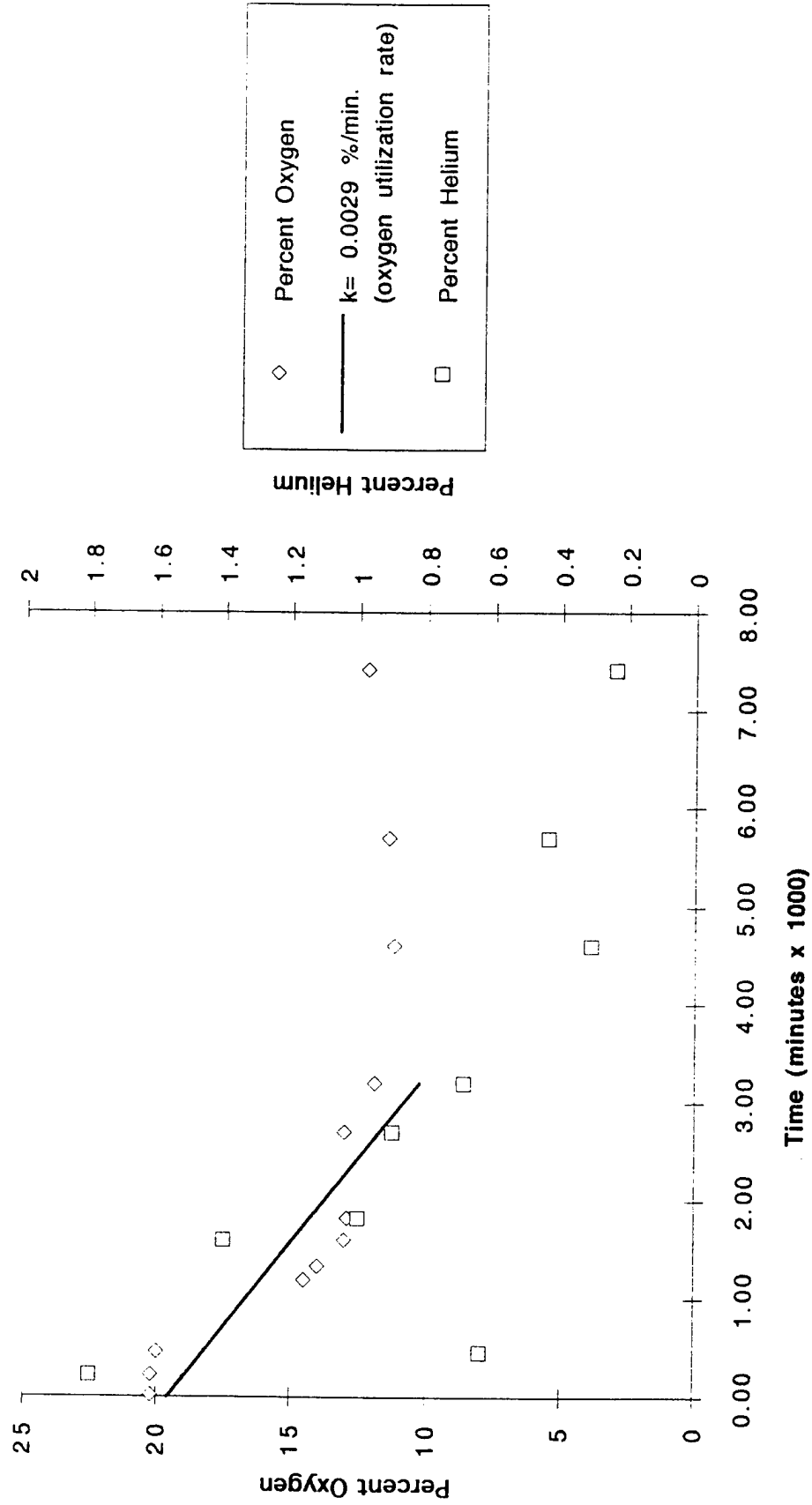


Figure 3.2
 Respiration Test
 Oxygen and Helium Concentrations
 Site FTA-06, MPB-36
 K.I. Sawyer AFB, Michigan

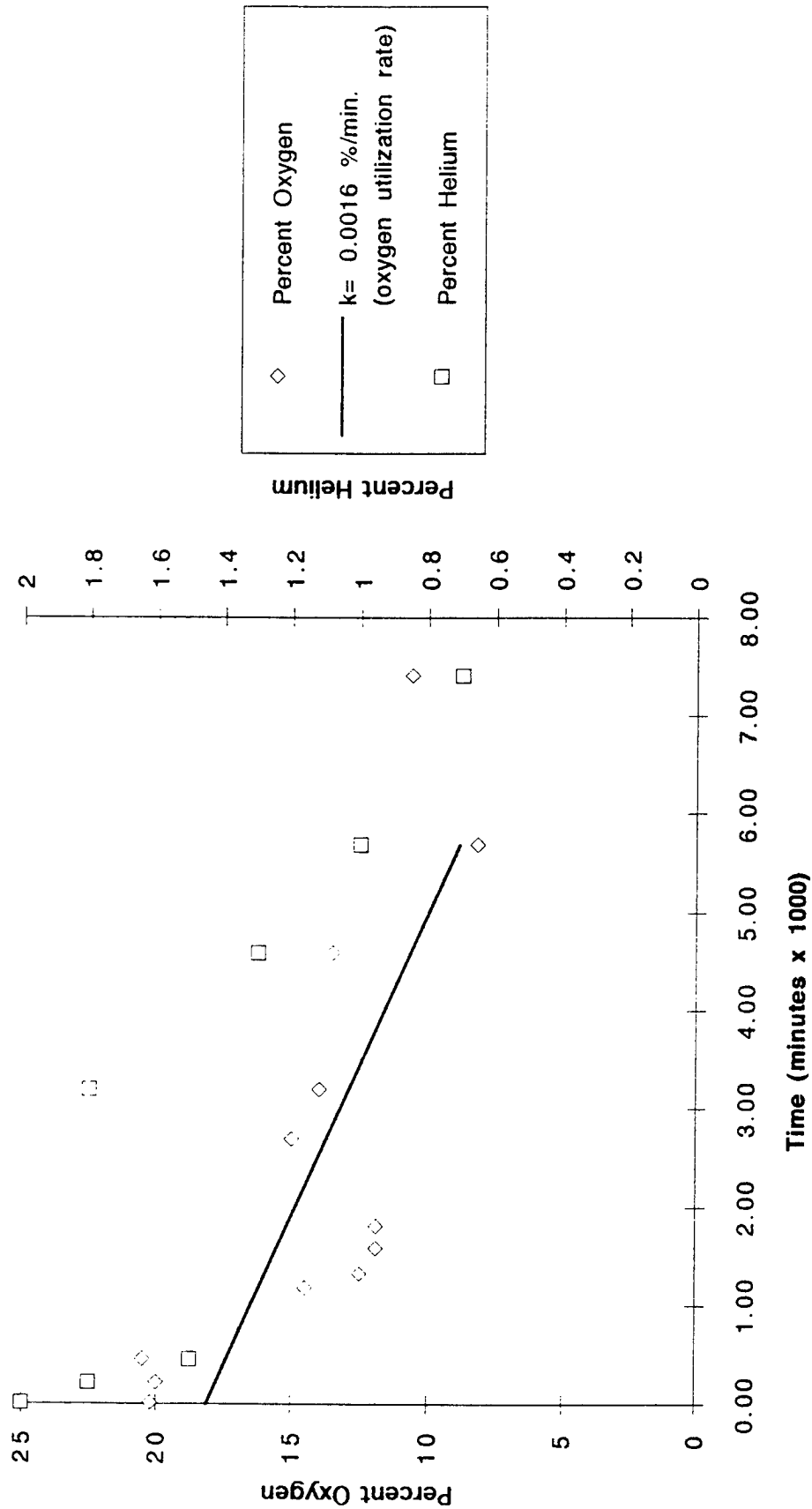


Figure 3.3
 Respiration Test
 Oxygen and Helium Concentrations
 Site FTA-06, MPB-71
 K.I. Sawyer AFB, Michigan

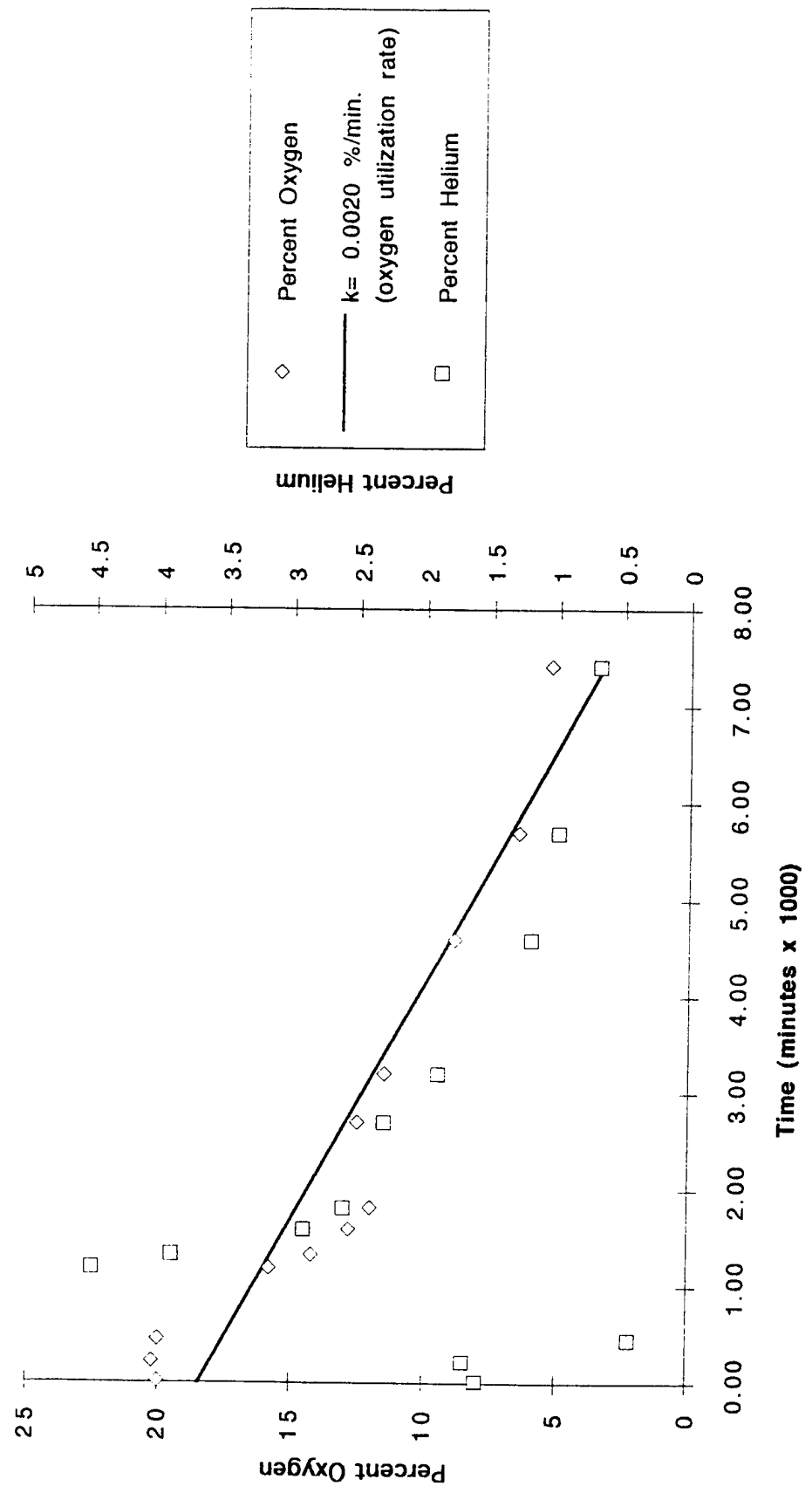


TABLE 3.7
OXYGEN UTILIZATION RATES
FTA-06
K.I. Sawyer AFB, Michigan

Monitoring Point	Oxygen Loss* (%)	Test Duration (min)	Oxygen Utilization Rate* (%/min)
KIS2-MPA-16	9.3	3210	0.0029
KIS2-MPB-36	9.3	5690	0.0016
KIS2-MPB-71	15.1	7420	0.002

*Values based on linear regression (Figures 3.1 through 3.3)

A significant interference in obtaining accurate respiration data at this site is the rapidly changing atmospheric pressure associated with the rapidly changing weather patterns observed at the site. These changes in air pressure result in movement of subsurface soil gasses, thus significantly impacting the measurements taken during the respiration testing. This also likely contributed to the observed decrease in helium over time.

Based on the oxygen utilization rates measured at MPA-16, MPB-36, and MPB-71, fuel degradation rates were calculated using calculated bulk densities and air-filled porosities, and a conservative ratio of 3.5 mg of oxygen consumed for every 1 mg of fuel biodegraded. Calculated soil bulk densities ranged from 1.8 to 1.9 kg/L. Calculated air-filled porosities ranged from 0.1 to 0.161 L/kg. The calculated fuel degradation rates for MPA-16, MPB-36, and MPB-71 were 880, 320, and 650 mg TPH/year, respectively.

3.4.2 FTA-07 In-Situ Respiration Rates

In-situ respiration tests were performed at FTA-07 at MPA-6, MPB-17, and MPC-6. These points initially all showed depressed oxygen levels, elevated carbon dioxide levels, and high TVH readings, as shown in Table 3.2. A 6 to 8 percent helium in air mixture was injected into each of these points for approximately 23 hours. Oxygen, carbon dioxide, and TVH concentrations were then measured in the soil gas at each of the three discrete monitoring points. These readings were collected periodically for approximately 5 days following cessation of the air injection period. The measured oxygen losses were then used to calculate biological oxygen utilization rates. The results of the in-situ respiration testing at FTA-07 are presented in Figures 3.4 through 3.6. Table 3.8 provides a summary of the oxygen utilization rates.

Helium was used as a conservative, inert tracer gas during the respiration testing. As shown in Figures 3.4 through 3.6, helium levels at all three points dropped significantly throughout the respiration testing. This indicates that some of the oxygen decrease observed may have been due to diffusion.

A significant interference in obtaining accurate respiration data at this site is the rapidly changing atmospheric pressure associated with the rapidly changing weather patterns observed at the site. These changes in air pressure result in the exchange of atmospheric 20.8 percent oxygen with subsurface soil gasses, thus significantly impacting the measurements taken during the respiration testing. This also likely contributed to the observed dilution of helium over time.

Based on the oxygen utilization rates measured at MPA-6, MPB-17, and MPC-6, fuel degradation rates were calculated using calculated bulk densities and air-filled porosities, and a conservative ratio of 3.5 mg of oxygen consumed for every 1 mg of fuel biodegraded. The calculated soil bulk density was 1.8 for all three points. Calculated air-filled porosities ranged from 0.139 to 0.15 L/kg. The calculated fuel degradation rates for MPA-6, MPB-17, and MPC-6 were 480, 140, and 4830 mg TPH/year, respectively.

Figure 3.4
 Respiration Test
 Oxygen and Helium Concentrations
 Site FTA-07, MPA-6
 K.I. Sawyer AFB, Michigan

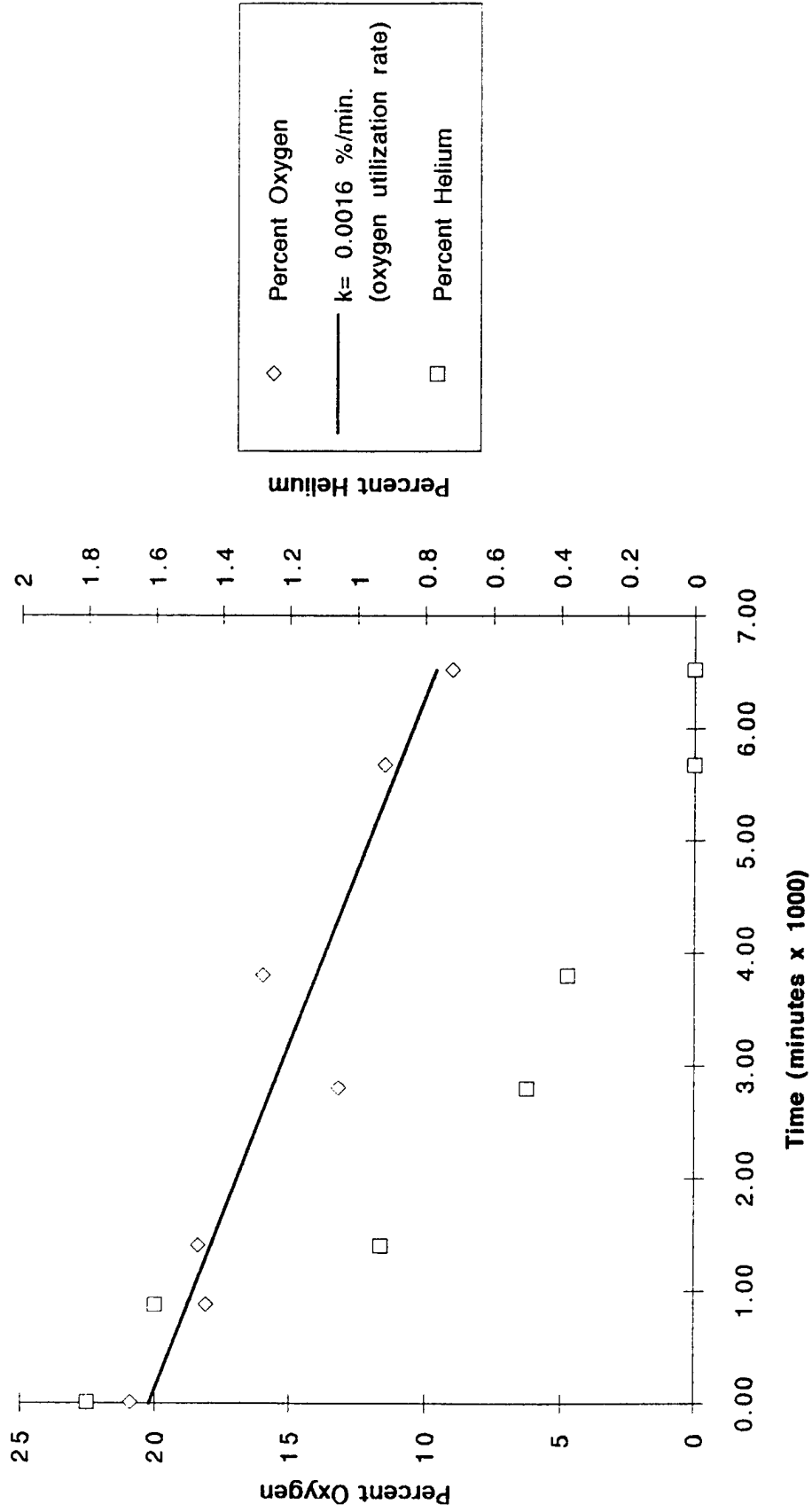


Figure 3.5
 Respiration Test
 Oxygen and Helium Concentrations
 Site FTA-07, MPB-17
 K.I. Sawyer AFB, Michigan

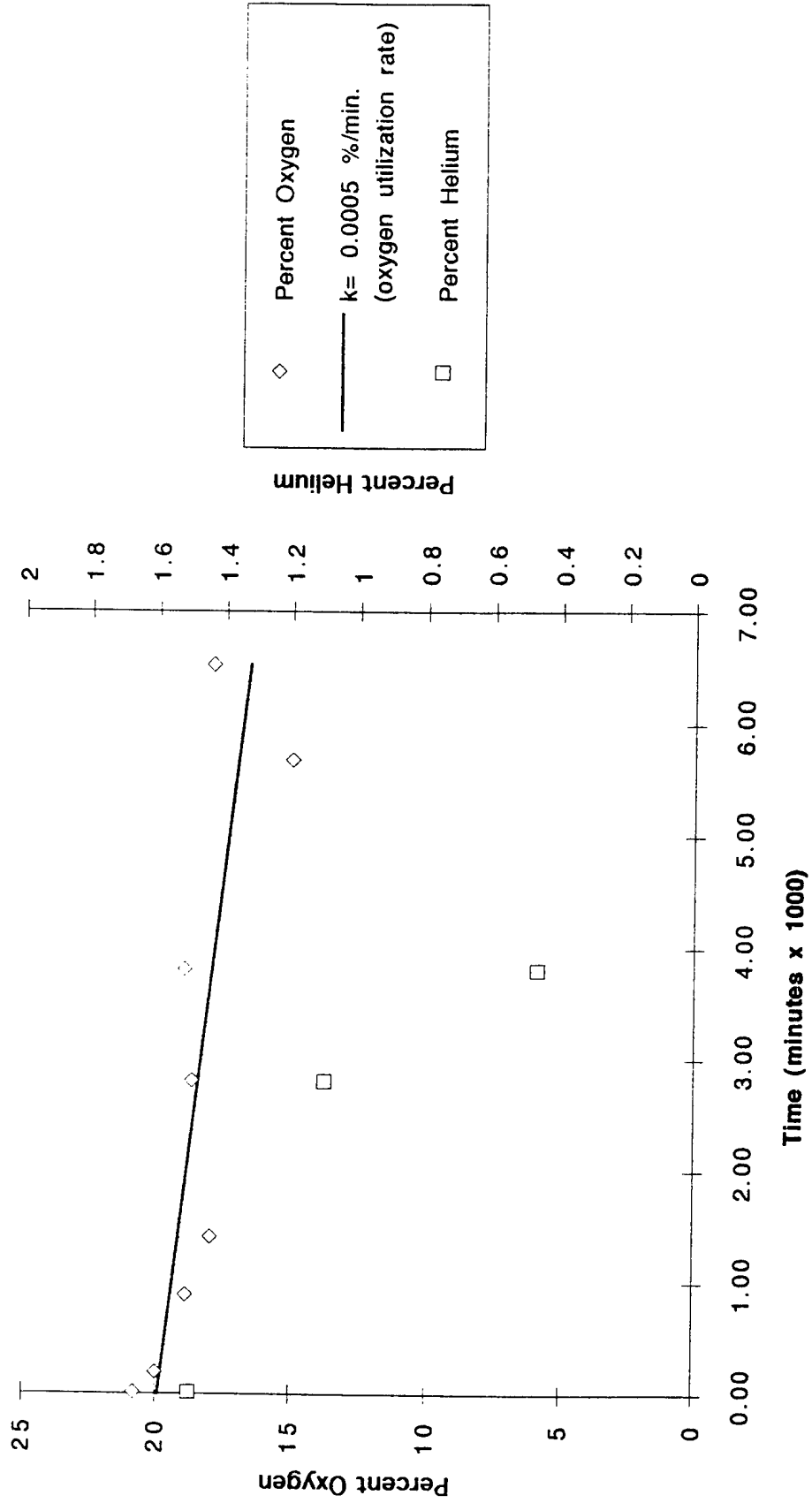


Figure 3.6
 Respiration Test
 Oxygen and Helium Concentrations
 Site FTA-07, MPC-6
 K.I. Sawyer AFB, Michigan

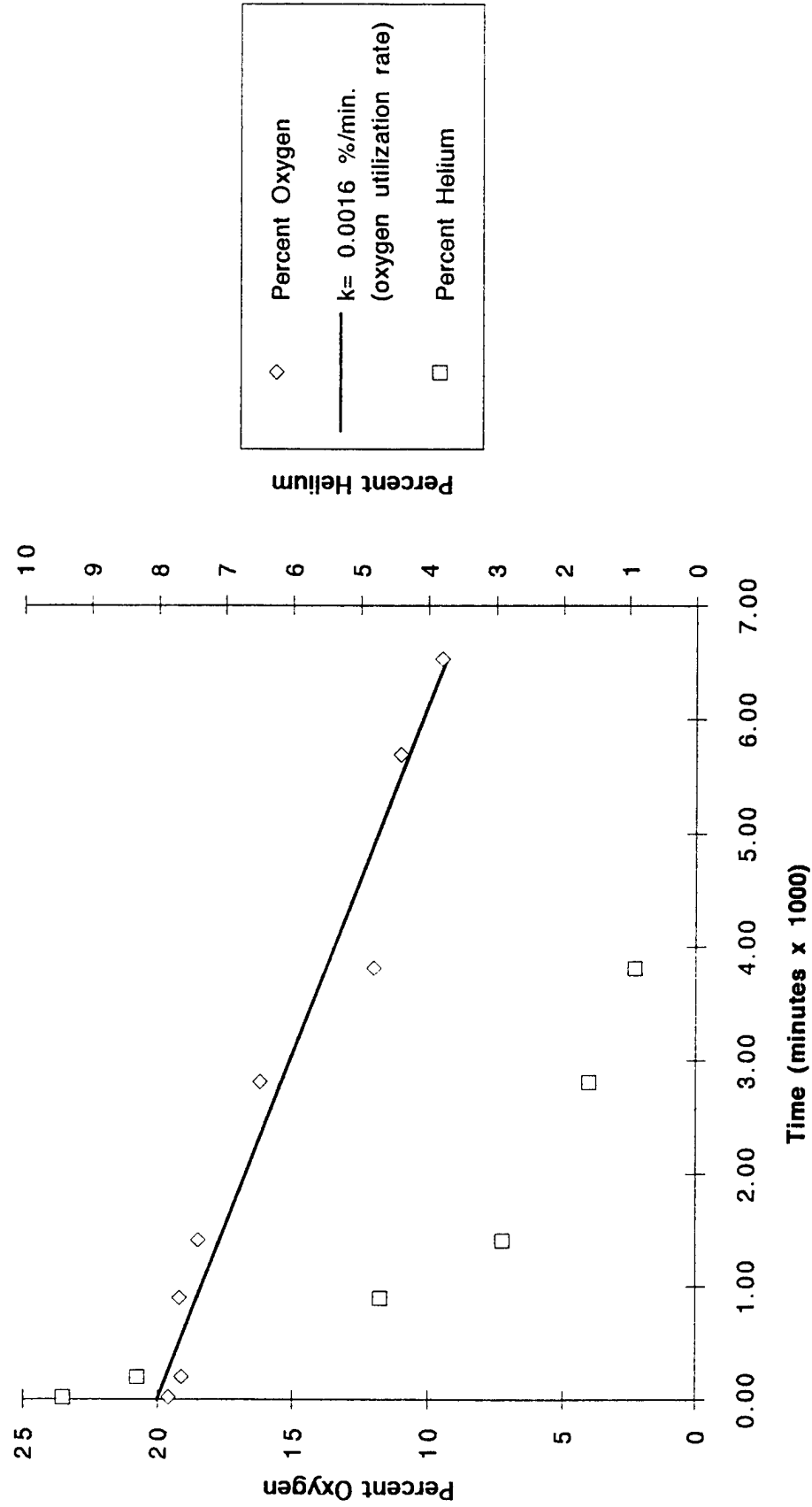


TABLE 3.8
OXYGEN UTILIZATION RATES
FTA-07
K.I. Sawyer AFB, Michigan

Monitoring Point	Oxygen Loss* (%)	Test Duration (min)	Oxygen Utilization Rate* (%/min)
KIS3-MPA-6	10.6	6520	0.0016
KIS3-MPB-17	3.3	6530	0.0005
KIS3-MPC-6	10.2	6530	0.0016

*Values based on linear regression (Figures 3.4 through 3.6)

3.5 Potential Air Emissions

The long-term potential for air emissions from full-scale bioventing operations at both FTA-06 and FTA-07 are considered to be low because of the age and type of the site contaminants (greater than five years, and jet fuel). Air emission tests performed at similar sites have demonstrated that air emissions from bioventing systems are minimal.

4.0 RECOMMENDATIONS

Initial bioventing testing at both FTA-06 and FTA-07 indicates that naturally occurring oxygen has been depleted in the pockets of contaminated soils, and that air injection will be an effective method of providing more uniform aerobic fuel biodegradation. AFCEE has recommended that air injection proceed at both sites to determine the long-term radius of oxygen influence and the effects of time, available nutrients and changing temperatures on fuel biodegradation rates. It is important to note that natural air exchanges (soil breathing) are also providing significant oxygen for natural biodegradation.

A 2.5 horsepower regenerative blower has been installed at each site to inject air at a rate of up to 150 cfm. This size blower was installed to allow for expansion of the bioventing system following conclusion of the one-year pilot test. For the extended pilot test, the bleed valves were opened on both systems to provide approximately 120 cfm of air into each VW. The blower at FTA-06 has been electrically connected and was turned on November 1, 1993 for the one-year extended test. The blower at FTA-07 has been electrically connected and was turned on October 8, 1993 for the one-year extended test. ES will return to the base at six months and one year after the one-year test period is begun to analyze the soil gas and conduct follow-up in-situ respiration tests. At the one year point, ES will also collect soil samples from the sites to determine the soil contamination levels after one year of in-situ treatment.

Based on the results of the first year of pilot-scale bioventing, AFCEE will recommend one of three options for the site:

1. Upgrade, if necessary, and continue operation of the bioventing system.
2. If the one year soil samples indicate that significant contamination removal has occurred. AFCEE may recommend additional soil sampling to confirm that the cleanup criteria has been achieved.
3. If significant difficulties or poor results are encountered during the bioventing pilot test, AFCEE may recommend removal of the blower system and proper abandonment of the VW and MPs.

5.0 REFERENCES

Engineering-Science, Inc. 1993. *Draft Bioventing Test Work Plan for Fire Training Pit 1 and Fire Training Pit 4 and Oil/Water Separator (FT-002)- Plattsburgh AFB, New York.* February.

Hinchee, R.E., Ong, S.K., Miller, R.N., Downey, D.C., Frandt, R. 1992. *Test Plan and Technical Protocol for a Field Treatability Test for Bioventing*. Columbus, Ohio. January.