

# LOAN DOCUMENT

PHOTOGRAPH THIS SHEET

①

DTIC ACCESSION NUMBER

LEVEL

INVENTORY

2 Part's

Bioreventing Pilot Test Work Plan for Site S-4

DOCUMENT IDENTIFICATION

Feb 93

**DISTRIBUTION STATEMENT A**  
Approved for Public Release  
Distribution Unlimited

DISTRIBUTION STATEMENT

|                    |                             |
|--------------------|-----------------------------|
| ACCESSION CODE     |                             |
| NTIS               | GRAM                        |
| DTIC               | TRAC                        |
| UNANNOUNCED        |                             |
| JUSTIFICATION      |                             |
| BY                 |                             |
| DISTRIBUTION/      |                             |
| AVAILABILITY CODES |                             |
| DISTRIBUTION       | AVAILABILITY AND/OR SPECIAL |
| A-1                |                             |

DISTRIBUTION STAMP

|  |
|--|
|  |
|--|

DATE ACCESSIONED

|  |
|--|
|  |
|--|

DATE RETURNED

|              |
|--------------|
| 20001127 014 |
|--------------|

DATE RECEIVED IN DTIC

|  |
|--|
|  |
|--|

REGISTERED OR CERTIFIED NUMBER

H  
A  
N  
D  
L  
E  
  
W  
I  
T  
H  
  
C  
A  
R  
E

PHOTOGRAPH THIS SHEET AND RETURN TO DTIC-FDAC

# **PART I**

**Bioventing Pilot Test Work Plan for  
Site S-4 and Site FC-2  
Kelly AFB, Texas**

# **PART II**

**Draft Interim Pilot Test Results Report for  
Site S-4 and Site FC-2  
Kelly AFB, Texas**

**Prepared For**

**Air Force Center for Environmental Excellence  
Brooks AFB, Texas**

**and**

**San Antonio Air Logistics Center/EMR  
Kelly AFB, Texas**

**ES**

**Engineering-Science, Inc.**

**February 1993**

1700 BROADWAY, SUITE 900  
DENVER, COLORADO 80290

**ES  
ENGINEERING-SCIENCE**

### DEFENSE TECHNICAL INFORMATION CENTER REQUEST FOR SCIENTIFIC AND TECHNICAL REPORTS

Title AFCEE Collection

**1. Report Availability** (Please check one box)

- This report is available. Complete sections 2a - 2f.
- This report is not available. Complete section 3.

**2a. Number of Copies Forwarded**

Each

**2b. Forwarding Date**

July/2000

**2c. Distribution Statement** (Please check ONE box)

DoD Directive 5230.24, "Distribution Statements on Technical Documents," 18 Mar 87, contains seven distribution statements, as described briefly below. Technical documents MUST be assigned a distribution statement.

- DISTRIBUTION STATEMENT A: Approved for public release. Distribution is unlimited.
- DISTRIBUTION STATEMENT B: Distribution authorized to U.S. Government Agencies only.
- DISTRIBUTION STATEMENT C: Distribution authorized to U.S. Government Agencies and their contractors.
- DISTRIBUTION STATEMENT D: Distribution authorized to U.S. Department of Defense (DoD) and U.S. DoD contractors only.
- DISTRIBUTION STATEMENT E: Distribution authorized to U.S. Department of Defense (DoD) components only.
- DISTRIBUTION STATEMENT F: Further dissemination only as directed by the controlling DoD office indicated below or by higher authority.
- DISTRIBUTION STATEMENT X: Distribution authorized to U.S. Government agencies and private individuals or enterprises eligible to obtain export-controlled technical data in accordance with DoD Directive 5230.25, Withholding of Unclassified Technical Data from Public Disclosure, 6 Nov 84.

**2d. Reason For the Above Distribution Statement** (in accordance with DoD Directive 5230.24)

**2e. Controlling Office**

HQ AFCEE

**2f. Date of Distribution Statement Determination**

15 Nov 2000

**3. This report is NOT forwarded for the following reasons.** (Please check appropriate box)

- It was previously forwarded to DTIC on ..... (date) and the AD number is .....
- It will be published at a later date. Enter approximate date if known. ....
- In accordance with the provisions of DoD Directive 3200.12, the requested document is not supplied because: .....

**Print or Type Name**

Laura Peña

**Telephone**

210-536-1431

**Signature**

Laura Peña

(For DTIC Use Only)

**AQ Number** M01-01-0339



DEPARTMENT OF THE AIR FORCE  
HEADQUARTERS AIR FORCE CENTER FOR ENVIRONMENTAL EXCELLENCE  
BROOKS AIR FORCE BASE TEXAS

25 Jul 94

MEMORANDUM FOR SA-ALC/EMR  
ATTN: Mr. Steve Escude

FROM: HQ AFCEE/ERT  
8001 Arnold Drive  
Brooks AFB TX 78235-5357

SUBJECT: Completion of One Year Bioventing Test, Site FC-2 Fire Training Area and Site S-4

The Air Force Center for Environmental Excellence (AFCEE) one-year bioventing test and evaluation projects at Site FC-2 and Site S-4 have been completed. For each site, Figure 1 provides general site information and Table 1 provides a summary of initial, six-month, and one-year fuel biodegradation rates measured at several monitoring points. Biodegradation rates have gradually decreased over the one-year pilot tests. These decreases are best explained by the reduction of contaminant levels as the bioventing continued. Table 2 provides a summary of initial and final soil and soil gas sampling results for total recoverable petroleum hydrocarbons (TRPH) and benzene, toluene, ethyl benzene, and xylenes (BTEX). Based on results from your sites and 108 other sites currently under operation, bioventing is cost-effectively remediating fuel contamination in a reasonable time frame. We recommend its application throughout FC-2, S-4, and at other sites on your installation using the criteria in the AFCEE Test Plan and Technical Protocol for a Field Treatability Test for Bioventing, May 1992, including Addendum One, February 1994.

The objective of the one year sampling effort was not to collect the large number of samples required for statistical significance. It was conducted to show relative reductions in TRPH and BTEX concentrations. Soil gas samples are somewhat similar to composite samples in that they are collected over a wider area. Thus, they provide a good indication of changes in soil gas profiles and volatile contaminant concentrations (see Addendum One to Test Plan and Technical Protocol for a Field Treatability Test for Bioventing - Using Soil Gas Surveys to Determine Bioventing Feasibility and Natural Attenuation Potential, February 1994). Soil samples, on the other hand, are discrete point samples subject to large variabilities over small distances/soil types. Given this variability, coupled with known sampling and analytical variabilities, a large number of samples would have to be collected to conclusively determine "real" changes in soil contamination. Because of the limited number of samples, these results should not be viewed as conclusive indicators of bioventing progress or evidence of the success or failure of this technology. In situ respiration tests are considered to be better indicators of hydrocarbon remediation than limited soil sampling.



Sampling results indicate that a reduction in BTEX has taken place in the soils within the treatment radius of the pilot vent well. All measurements indicate that fuel biodegradation is progressing at a significant rate. AFCEE recommends that the bioventing pilot system continue to operate while planning for an expansion of the system for full-scale remediation. System expansion to a full-scale bioventing system can be contracted through AFCEE. Please contact Jerry Hansen, AFCEE/ERT, DSN 240-4353, COM 210-536-4353, to discuss technical and contractual options for full-scale expansion.

Data from your base and many others indicate that BTEX compounds are preferentially biodegraded over TRPH. Since BTEX compounds represent the most toxic and mobile fuel constituents, a BTEX standard is a risk-based standard. We understand that the state of Texas uses a site specific risk based evaluation for determining cleanup requirements. Attachment 3 summarizes the BTEX/TRPH issue and a report to be sent under separate cover will assist you in negotiating for a BTEX cleanup standard.

In general, quantitative destruction of BTEX will occur over a one- to two-year bioventing period. Soil gas surveys and respiration tests can be used as BTEX destruction indicators. If a non-risk-based/TRPH cleanup is chosen, the pilot and full-scale systems should be operated until respiration rates approach background rates. We recommend that confirmatory soil sampling be conducted four-six months after background respiration rates are approached.

Because this is a streamlined test and evaluation project, our contract does not provide for additional reports to the base on pilot study results. The interim results report contains as-builts and initial data. This letter summarizes all data collected and provides next step recommendations. AFCEE is no longer responsible for the operation, maintenance, or monitoring of the Site FC-2 and Site S-4 bioventing systems. We are initiating a contract to extend monitoring at some sites beyond the initial one year test. Monitoring will include soil gas and respiration tests to document hydrocarbon degradation and will also include the collection of sufficient final soil samples to statistically demonstrate site cleanup. If you are interested, please call us.

The blowers and accessories are now base property and should continue to be used on these or other bioventing sites. Although current equipment is explosion proof, under no circumstances should it be used for soil vapor extraction unless appropriate explosion-proof wiring is provided. If the base does not want to keep the blowers or if you have further questions, please contact us .

On behalf of the AFCEE/ERT staff, I would like to thank you for your support of these bioventing test and evaluation projects. The information gained from each site will be invaluable in evaluating this technology and will promote its successful application on other DOD, government, and private sites. I have attached a customer satisfaction survey. Please take a few minutes to fill it out and tell us how we did. We look forward to hearing from you.



ROSS N. MILLER, Lt Col, USAF, BSC  
Chief, Technology Transfer Division

Attachments:

1. Site FC-2 Map and Data
2. Site S-4 Map and Data
3. "Using Risk-based Standards will Shorten Cleanup Time at Petroleum Contaminated Sites"
4. Survey
5. Addendum

cc:

AFCEE/ERD (Lt Hamel)  
HQ AFMC/CEVR  
HQ USAF/CEVR

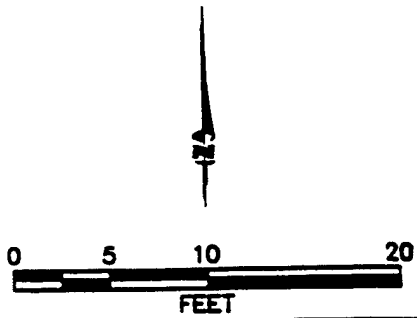
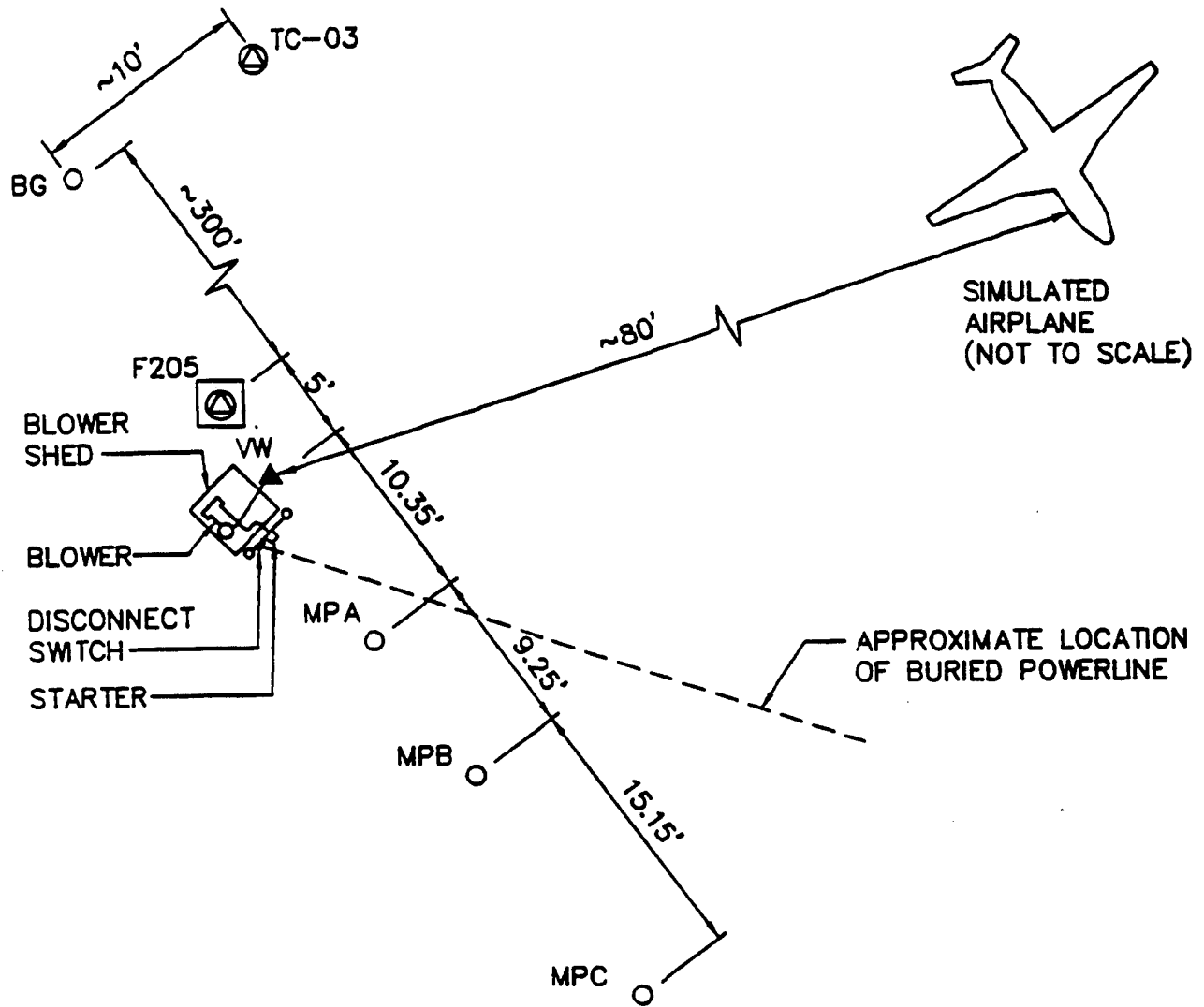

**LEGEND**

- ⊗ EXISTING GROUNDWATER MONITORING WELL
- VW ▲ CENTRAL VENT WELL (AIR INJECTION)
- MPA ○ MONITORING POINT

**FIGURE 1**

**SITE FC-2  
AS-BUILT SITE PLAN**

KELLY AFB, TEXAS

**ENGINEERING-SCIENCE, INC.**

Denver, Colorado

**TABLE 1**  
**SITE FC-2**  
**RESPIRATION AND DEGRADATION RATES**  
**KELLY AFB, TEXAS**

| Location - Depth<br>(feet bgs) | Initial = December 1992                   |   | 6 - Month = June 1993       |   | 1 - Year = January 1994                           |                             |   |                                     |                             |
|--------------------------------|---|---|-----------------------------|---|---|-----------------------------|---|-------------------------------------|-----------------------------|
|                                | K <sub>o</sub><br>(% O <sub>2</sub> /min) | Degradation<br>Rate<br>(mg/kg/year) <sup>a/</sup> | Soil<br>Temperature<br>(°C) | K <sub>o</sub><br>(% O <sub>2</sub> /min) | Degradation<br>Rate <sup>b/</sup><br>(mg/kg/year) | Soil<br>Temperature<br>(°C) | K <sub>o</sub><br>(% O <sub>2</sub> /min) | Degradation<br>Rate<br>(mg/kg/year) | Soil<br>Temperature<br>(°C) |
| MPA-4                          | NS <sup>d/</sup>                          | NS  | 18.0                        | NS  | NS  | 26.9                        | NS  | NS                                  | 16.7                        |
| MPA-13.5                       | 0.040                                     | 8100  | 24.9                        | 0.013                                     | 2600  | 26.4                        | 0.0058                                    | 1200                                | 26.4                        |
| MPB-9                          | 0.021                                     | 3500  | NS                          | 0.0039                                    | 480   | NS                          | 0.0023                                    | 180                                 | NS                          |
| MPB-13.5                       | 0.025                                     | 4200  | NS                          | 0.0019                                    | 230   | NS                          | 0.0083                                    | 650                                 | NS                          |
| MPC-13.5                       | 0.040                                     | 6700 <sup>d/</sup>                                | NS                          | 0.029                                     | 3600 <sup>d/</sup>                                | NS                          | 0.022                                     | 1700 <sup>d/</sup>                  | NS                          |

<sup>a/</sup> Milligrams hydrocarbons per kilogram soil per year.

<sup>b/</sup> Assumes moisture content of the soil is average of initial and final moistures.

<sup>c/</sup> Not Sampled.

<sup>d/</sup> Degradation rate calculated assuming MPC-13.5 soil moisture content the same as MPB-13.5.



BERMAN ROAD

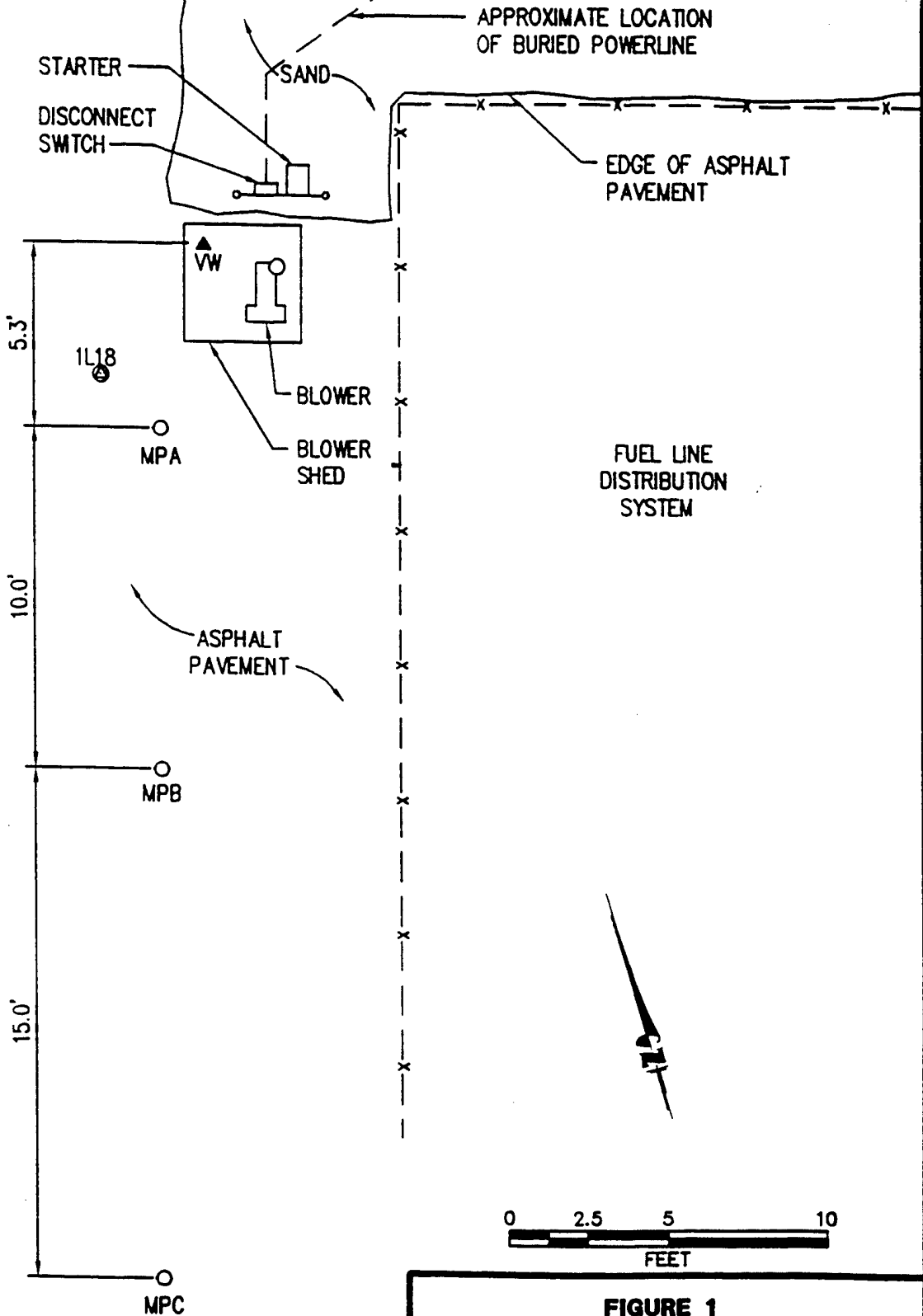

**LEGEND**

- VW▲ INJECTION VENT WELL
- MPC○ MONITORING POINT
- EXISTING GROUNDWATER MONITORING WELL
- X — FENCE

**FIGURE 1**

**SITE S-4  
AS-BUILT SITE PLAN**

KELLY AFB, TEXAS

**ENGINEERING-SCIENCE, INC.**

Denver, Colorado

**TABLE 1**  
**SITE S-4**  
**RESPIRATION AND DEGRADATION RATES**  
**KELLY AFB, TEXAS**

| Location - Depth, feet bgs | Initial = December 1992                   |   |                             | 6-Month = June 1993                       |   |                             | 1-Year = January 1994                     |                                     |                             |
|----------------------------|---|---|-----------------------------|---|---|-----------------------------|---|-------------------------------------|-----------------------------|
|                            | K <sub>o</sub><br>(% O <sub>2</sub> /min) | Degradation<br>Rate<br>(mg/kg/year) <sup>a/</sup> | Soil<br>Temperature<br>(°C) | K <sub>o</sub><br>(% O <sub>2</sub> /min) | Degradation<br>Rate <sup>b/</sup><br>(mg/kg/year) | Soil<br>Temperature<br>(°C) | K <sub>o</sub><br>(% O <sub>2</sub> /min) | Degradation<br>Rate<br>(mg/kg/year) | Soil<br>Temperature<br>(°C) |
| VW-7-17                    | .041                                      | 12000   | NS <sup>c/</sup>            | .0013                                     | 290   | NS                          | NS  | NS                                  | NS                          |
| MPA-5                      | NS  | NS  | 20.4                        | NS  | NS  | 27.4                        | NS  | NS                                  | 18.2                        |
| MPA-12.5                   | .046                                      | 1900  | 23.2                        | .0041                                     | 210   | 25.2                        | .0021                                     | 160                                 | 24.4                        |
| MPB-9                      | .033                                      | 9800 <sup>d/</sup>                                | NS                          | .0019                                     | 420 <sup>d/</sup>                                 | NS                          | .0011                                     | 160 <sup>d/</sup>                   | NS                          |
| MPB-12.5                   | .035                                      | 5500  | NS                          | .0054                                     | 900   | NS                          | .0026                                     | 430                                 | NS                          |
| MPC-9                      | NS  | NS  | NS                          | .0033                                     | 740 <sup>d/</sup>                                 | NS                          | .0018                                     | 260 <sup>d/</sup>                   | NS                          |
| MPC-12.5                   | .042                                      | 7900 <sup>d/</sup>                                | NS                          | .012                                      | 2200 <sup>d/</sup>                                | NS                          | NS  | NS                                  | NS                          |

<sup>a/</sup> Milligrams of hydrocarbons per kilogram of soil per year.

<sup>b/</sup> Assumes moisture content of the soil is average of initial and final moistures.

<sup>c/</sup> NS=Not Sampled.

<sup>d/</sup> Degradation rate calculated assuming MPB-9 and MPC-9 soil moisture content the same as VW.

<sup>e/</sup> Degradation rate calculated assuming MPC-12.5 soil moisture content the same as MPB-12.5.

**TABLE 2**  
**SITE S-4**  
**INITIAL AND 1-YEAR SOIL AND SOIL GAS ANALYTICAL RESULTS**  
**KELLY AFB, TEXAS**

| Analyte (Units) <sup>a/</sup> | Sample Location - Depth<br>(feet below ground surface) |                      |          |                      |          |                      |
|-------------------------------|--|----------------------|----------|----------------------|----------|----------------------|
|                               | VW (7-17)  |                      | MPA-12.5 |                      | MPC-12.5 |                      |
|                               | Initial <sup>b/</sup>                                  | 1-Year <sup>c/</sup> | Initial  | 1-Year               | Initial  | 1-Year <sup>d/</sup> |
| Soil Gas Hydrocarbons         |  |                      |          |                      |          |                      |
| TVH (ppmv)                    | 29500  | 23                   | 16,000   | 52                   | 64,000   | 1,200                |
| Benzene (ppmv)                | 130  | .044                 | 50       | 0.028                | 420      | <.10                 |
| Toluene (ppmv)                | 18.5   | .035                 | 7.7      | 0.410                | 39       | 2.20                 |
| Ethylbenzene (ppmv)           | 20.5   | .019                 | <3.5     | 0.140                | 45       | 0.75                 |
| Xylenes (ppmv)                | 17.5   | .041                 | <3.5     | 0.450                | 39       | 1.40                 |
| Soil Hydrocarbons             |  |                      |          |                      |          |                      |
|                               | VW-10  |                      | MPA-13   |                      | MPB-13   |                      |
|                               | Initial <sup>e/</sup>                                  | 1-Year <sup>f/</sup> | Initial  | 1-Year <sup>g/</sup> | Initial  | 1-Year               |
| TRPH (mg/kg)                  | 1600   | 131                  | 56       | 658.0                | 1,100    | 985.0                |
| Benzene (mg/kg)               | <.35   | <.08                 | <.42     | <.084                | <.76     | <.078                |
| Toluene (mg/kg)               | 11.0   | .41                  | 5.3      | 0.52                 | 110      | 1.9                  |
| Ethylbenzene (mg/kg)          | <.29   | <.08                 | <.35     | <.084                | <.63     | <.078                |
| Xylenes (mg/kg)               | 16.0   | .11                  | 11.0     | 2.6                  | 13.0     | 1.8                  |
| Moisture (%)                  | 13.9   | 22.0                 | 28.3     | 26.2                 | 21.0     | 20.5                 |

<sup>a/</sup> TVH = total volatile hydrocarbons; ppmv = parts per million, volume per volume;  
<sup>b/</sup> TRPH = total recoverable petroleum hydrocarbons; mg/kg = milligrams per kilogram.  
<sup>c/</sup> Initial soil gas samples collected on 12/14/92.  
<sup>d/</sup> 1-Year soil gas samples collected on 1/21/94.  
<sup>e/</sup> 1-Year soil gas for MPC was collected from MPC-9.  
<sup>f/</sup> Initial soil samples collected on 12/10/92 and 12/11/92.  
<sup>g/</sup> 1-Year soil sample for vent well collected on 5/18/94.  
<sup>h/</sup> 1-Year soil samples for monitoring points collected on 1/8/94.

**PART I**  
**BIOVENTING PILOT TEST WORK PLAN**  
**FOR**  
**SITE S-4 AND SITE FC-2**  
**KELLY AFB, TEXAS**

**Prepared for:**

**Air Force Center for Environmental Excellence**  
**Brooks AFB, Texas**

**and**

**San Antonio Air Logistics Center/EMR**  
**Kelly AFB, Texas**

**February 1993**

**by:**

**Engineering-Science, Inc.**  
**1700 Broadway, Suite 900**  
**Denver, Colorado**

**CONTENTS**  
**PART I - BIOVENTING PILOT TEST WORK PLAN FOR**  
**SITE S-4 AND SITE FC-2**  
**KELLY AFB, TEXAS**

|       |   | <u>Page</u> |
|-------|---|-------------|
| 1.0   | Introduction.....                           | I-1         |
| 2.0   | Site Description.....                       | I-2         |
| 2.1   | Site S-4.....                               | I-2         |
| 2.1.1 | Site History and Location .....             | I-2         |
| 2.1.2 | Site Geology.....                           | I-2         |
| 2.1.3 | Site Contaminants .....                     | I-2         |
| 2.2   | Site FC-2, Fire Control Training Area.....  | I-4         |
| 2.2.1 | History and Location .....                  | I-4         |
| 2.2.2 | Site Geology.....                           | I-4         |
| 2.2.3 | Site Contaminants .....                     | I-4         |
| 3.0   | Pilot Test Activities.....                  | I-7         |
| 3.1   | Bioventing Test Design For Site S-4.....    | I-7         |
| 3.2   | Site FC-2.....                              | I-9         |
| 3.3   | Background Well .....                       | I-13        |
| 3.4   | Handling of Drill Cuttings.....             | I-13        |
| 3.5   | Soil and Soil Gas Sampling .....            | I-16        |
| 3.5.1 | Soil Samples .....                          | I-16        |
| 3.5.2 | Soil Gas Samples .....                      | I-16        |
| 3.6   | Blower System .....                         | I-16        |
| 3.7   | <i>In Situ</i> Respiration Tests .....      | I-18        |
| 3.8   | Air Permeability Test.....                  | I-18        |
| 3.9   | Extended Pilot Test Bioventing System ..... | I-18        |
| 4.0   | Exceptions to Protocol Procedures .....     | I-19        |
| 5.0   | Base Support Requirements.....              | I-19        |
| 6.0   | Project Schedule.....                       | I-20        |
| 7.0   | Points of Contact.....                      | I-20        |
| 8.0   | References.....                             | I-20        |

**FIGURES**

| <u>No.</u> | <u>Title</u>  | <u>Page</u> |
|------------|---|-------------|
| 2.1        | Site S-4 Site Plan .....                                      | I-3         |
| 2.2        | Site FC-2 Site Plan and Profile Location Map.....             | I-5         |
| 2.3        | Site FC-2 Geologic Profile A-A'.....                          | I-6         |
| 3.1        | Site S-4 Proposed Vent Well/Monitoring Point Locations.....   | I-8         |
| 3.2        | Site S-4 Injection Vent Well Construction Detail.....         | I-10        |
| 3.3        | Site S-4 Monitoring Point Construction Detail .....           | I-11        |
| 3.4        | Site FC-2 Proposed Vent Well/Monitoring Point Locations ..... | I-12        |

## FIGURES

| <u>No.</u> | <u>Title</u>  | <u>Page</u> |
|------------|---|-------------|
| 3.5        | Site FC-2 Injection Vent Well Construction Detail .....       | I-14        |
| 3.6        | Site FC-2 Monitoring Point Construction Detail .....          | I-15        |
| 3.7        | Blower System Instrumentation Diagram for Air Injection ..... | I-17        |

**PART I**

**BIOVENTING PILOT TEST WORK PLAN FOR  
SITE S-4 AND SITE FC-2  
KELLY AFB, TEXAS**

**1.0 INTRODUCTION**

This work plan presents the scope of multiphase bioventing pilot tests for *in situ* treatment of fuel-contaminated soils at Site S-4 and Site FC-2 at Kelly Air Force Base (AFB), Texas. The pilot tests will be performed by Engineering-Science, Inc. (ES). The three primary objectives of the proposed pilot tests are: 1) to assess the potential for supplying oxygen throughout the contaminated soil interval, 2) to determine the rate at which indigenous microorganisms will degrade fuel when supplied with oxygen-rich soil gas, and 3) to evaluate the potential for sustaining these rates of biodegradation until fuel contamination is remediated to concentrations below regulatory standards.

The pilot tests will be conducted in two phases. A vent well (VW) and monitoring points (MPs) will be installed during site investigation activities. The initial test phase at each site will also include an *in situ* respiration test, an air permeability test, and installation of a blower system for air injection. This initial testing is expected to take approximately 2 weeks. During the second phase, the bioventing systems will be operated and monitored over a 1-year period.

If bioventing proves to be an effective means of remediating soil contamination at these sites, pilot test data may be used to design full-scale remediation systems and to estimate the time required for site cleanup. An added benefit of the pilot testing at Site S-4 and Site FC-2 is that a significant amount of the fuel contamination should be biodegraded during the 1-year pilot test, as the testing will take place within the most contaminated soils at the sites. Additional background information on the development and recent success of the bioventing technology is found in the document entitled *Test Plan and Technical Protocol for a Field Treatability Test for Bioventing* (Hinchee et al., 1992). This protocol document will serve as the primary reference for pilot test well designs and the detailed procedures to be used during the test.

## **2.0 SITE DESCRIPTION**

### **2.1 Site S-4**

#### **2.1.1 Site History and Location**

Site S-4 is located at the southeastern edge of Kelly AFB Zone 3, and extends off base across Berman Road into the Union Pacific Railroad yard and the Quintana Road residential area (Figure 2.1). Within Site S-4 are three underground storage tank (UST) facilities and associated underground pipelines. Two of these facilities remain open and active; the third (U/371) was removed after the detection of severe tank corrosion.

Tank facility U/371 was constructed in 1943, and contained five USTs and 2,000 feet of underground piping. In 1986 the facility was abandoned and the tanks were removed. U/371 was used to store and supply JP-4 jet fuel to aircraft facilities. Approximately 2,000 feet of JP-4 pipeline was taken out of service in 1982 after pressure tests revealed extensive leaks (NUS, 1990).

#### **2.1.2 Site Geology**

Because the bioventing technology is applied to the unsaturated soils, this section will primarily discuss soils above the shallow aquifer. Soils at Site S-4 consist of Quaternary alluvial deposits comprised of nonuniform layers of sand, gravel, silt, and clay. Groundwater is encountered at fluctuating depths of approximately 14 to 16 feet below ground surface (bgs) (NUS, 1990).

Due to the heterogeneous nature of these soils, the permeability of soils to the air flow may vary by orders of magnitude across the site. The key to effective bioventing at this site will be to maintain high levels of oxygen within the less permeable clay layers. Past ES experience with bioventing projects in similar alluvial soils has demonstrated that oxygen can be distributed throughout these deposits. Trilevel soil vapor MPs will be positioned in three locations to study the subsurface oxygen distribution pattern during the pilot test at this site.

#### **2.1.3 Site Contaminants**

Although the extent of contamination in the vicinity of the proposed bioventing site has not been fully defined, the site is known to be contaminated with JP-4 fuel. The likely sources of both the soil and groundwater contamination are releases from the UST facilities and from the underground JP-4 pipeline leaks. Benzene, toluene, ethylbenzene, and xylenes (BTEX) were detected in the capillary fringe at concentrations of up to 407 milligrams per kilogram (mg/kg), and at an average concentration of over 100 mg/kg. The proposed test site is located within an area of known free product influence and is expected to have a vertical interval of contamination from approximately 11 to 16 feet bgs, based on groundwater fluctuations and free product thickness measured in monitoring wells. Total petroleum hydrocarbon (TPH) concentrations in this interval are expected to be in excess of 1,000 mg/kg.

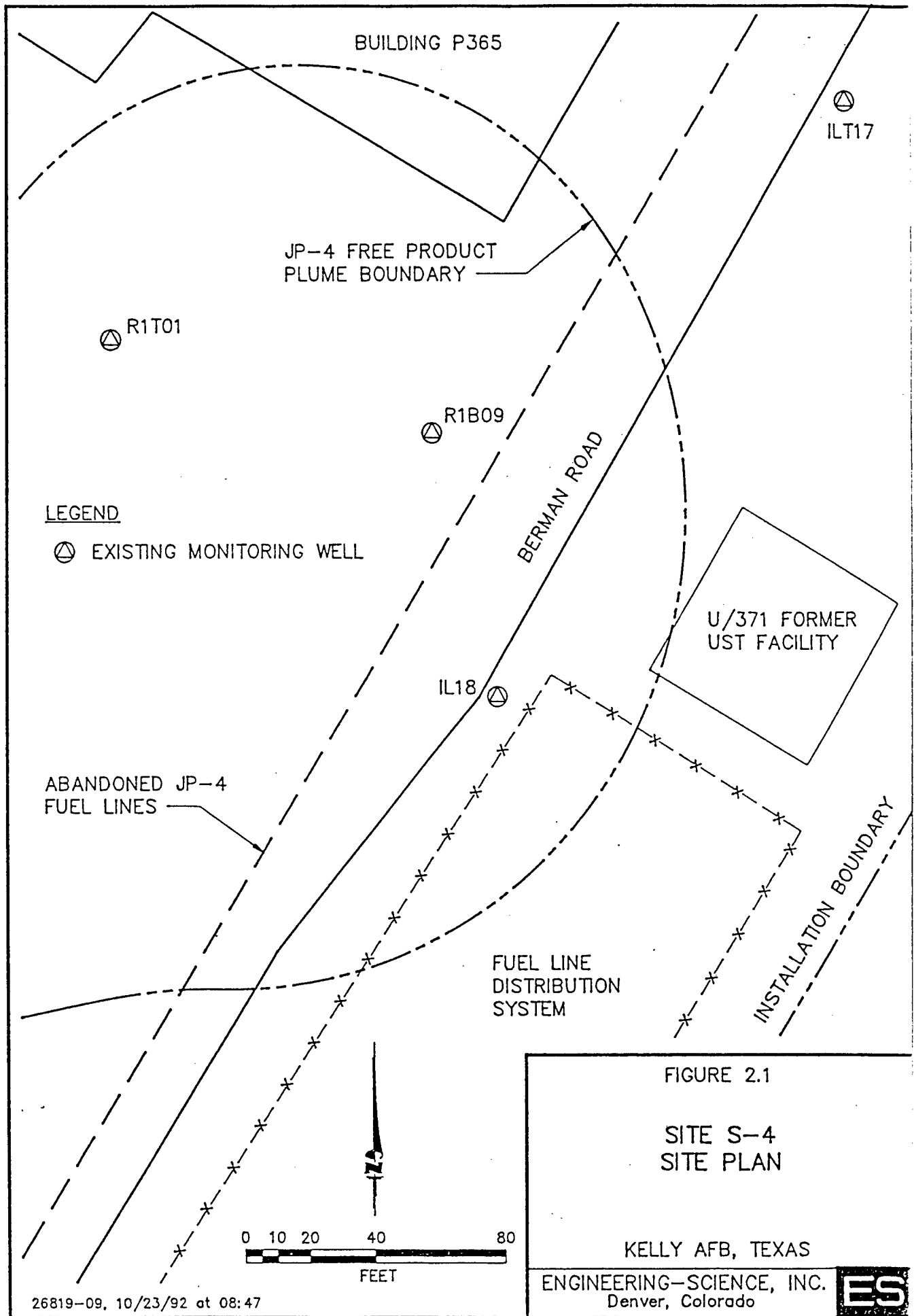

## 2.2 Site FC-2, Fire Control Training Area

### 2.2.1 History and Location

Site FC-2 consists of a circular area approximately 150 feet in diameter located northwest of the industrial waste sludge lagoon (Site SA-2) and approximately 100 feet north of Leon Creek (Figure 2.2). The earth-bermed area was used from the 1950s to 1981 for fire control training exercises. Waste petroleum, oil, and lubricant (POL) and fuel fires were set on a simulated airplane at the center of the site two to four times a year. The fires were extinguished with a water/protein mixture or an aqueous, film-forming foam. No containment system was used to prevent direct infiltration of fuels into the soils.

A Phase II study conducted in 1988 indicated that total recoverable petroleum hydrocarbons (TRPH) were detected at a maximum concentration of 10,000 mg/kg. A visible sheen of floating product was observed in monitoring well F202, located 120 feet southeast of the simulated airplane. Dissolved benzene was also found in the groundwater at F202 (Haliburton NUS, 1991). The resulting hydrocarbon contamination found at this site are the targets for the bioventing RA technology.

### 2.2.2 Site Geology

Eight to 22 feet of fill material is present over most of Site FC-2. This material is a poorly sorted, brown clay to clayey gravel with minor amounts of caliche, sand, and silt. Figure 2.3 illustrates the relationship between the fill material, the units of the alluvial aquifer, and the Navarro clay in cross-sectional view. The location of this profile is shown on the site map, Figure 2.2. Fill materials or undisturbed silts and clays are the surficial materials at the site. Below these materials, coarse-grained sands, gravels, or clayey-gravel (1 to 11 feet thick) exist. Groundwater is encountered at varying depths of approximately 15 to 18 feet, and generally flows south-southeasterly toward Leon Creek with a gradient of approximately 0.001 foot per foot (Haliburton NUS, 1992). The generally homogeneous fill material soils at this site appear to be well suited for the bioventing treatment.

### 2.2.3 Site Contaminants

The primary contaminants at this site are fuel residuals which have migrated to a depth of approximately 15 to 18 feet where shallow groundwater is encountered. Free product was observed in monitoring well F202, located 120 feet southeast of the simulated airplane (Figure 2.2). Laboratory analyses of soils for volatile organic compounds (VOCs) indicate that soils are most highly contaminated to the southeast of the simulated airplane. In the pilot test area, the highest VOC concentration was detected in borehole F2B06, where acetone was detected at 730 micrograms per kilogram ( $\mu\text{g}/\text{kg}$ ).

TPH concentrations were highest in shallow soils (within 7 feet of the ground surface) near the simulated airplane (3,100 and 4,600 mg/kg at borings F2S01 and F2S03 respectively). However, a sample from a 2-to 4-foot depth from boring F2B14, located away from the central site area, contained 3,200 mg/kg TPH. This high concentration away from the simulated airplane may be the result of past fuel spills or training exercises not involving the airplane.

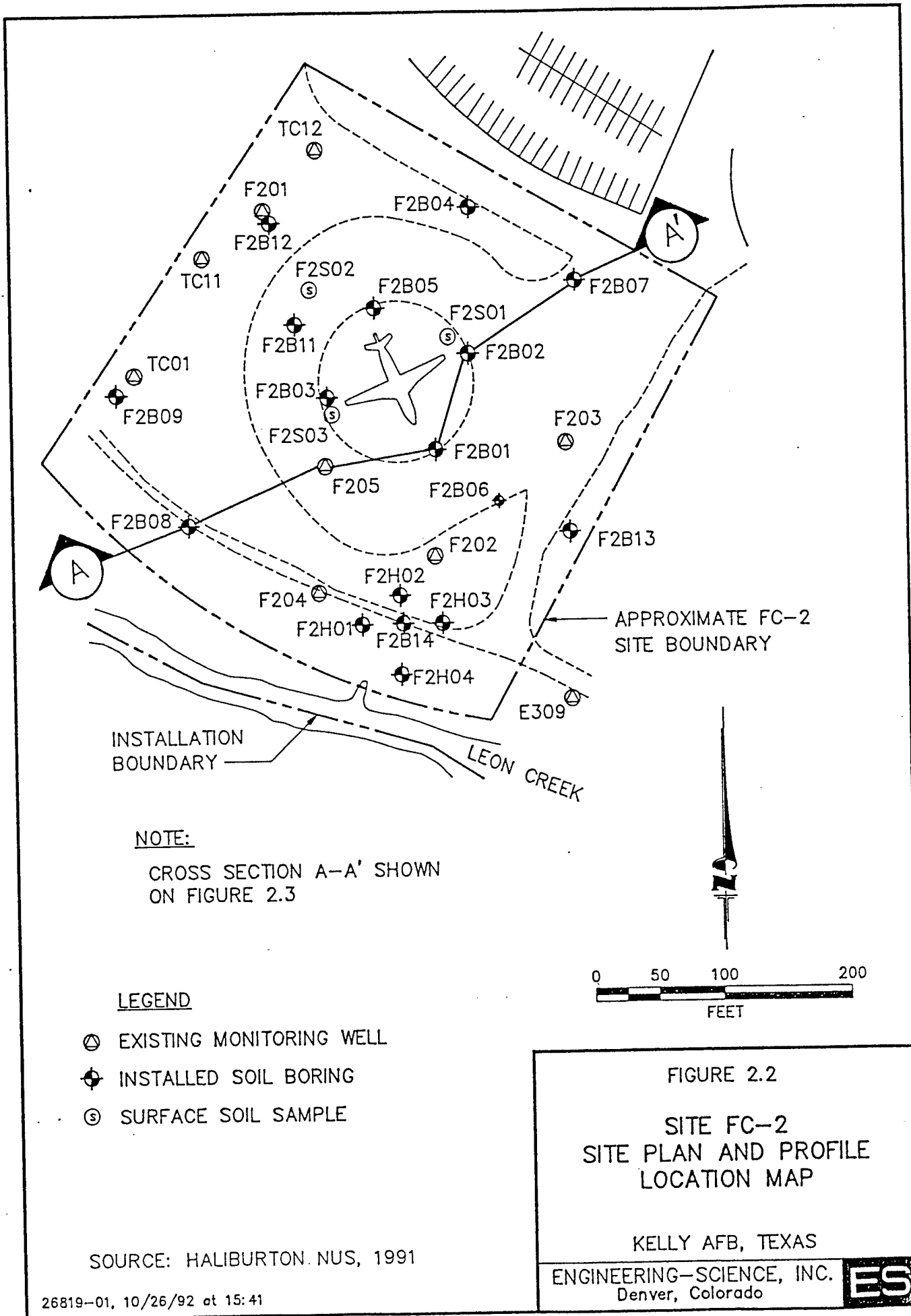

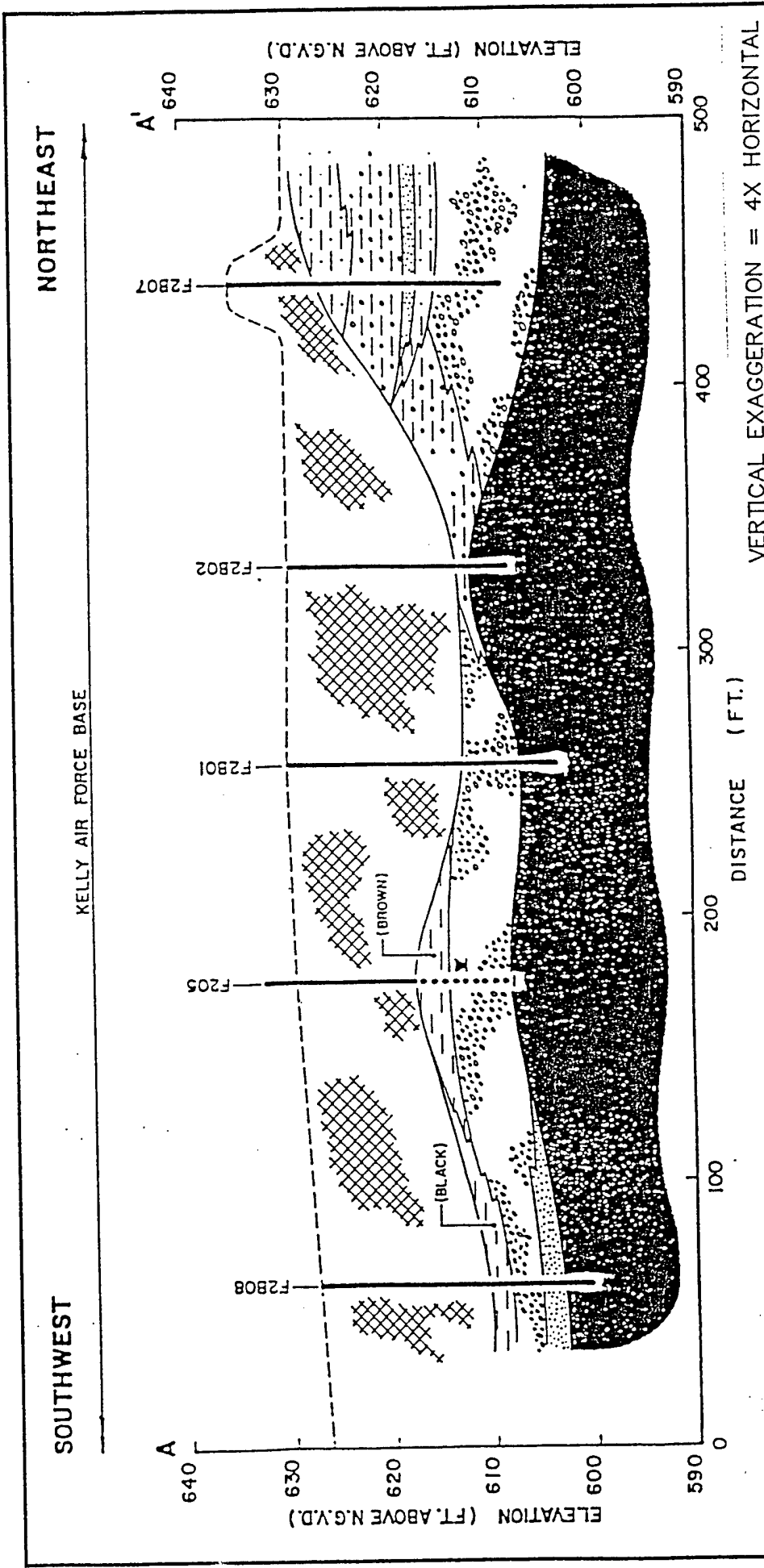

FIGURE 2.3

SITE FC-2

GEOLOGIC PROFILE A-A'

KELLY AFB, TEXAS

ENGINEERING-SCIENCE, INC.  
Denver, Colorado

**LEGEND**

|                   |               |                   |               |                   |                        |
|-------------------|---------------|-------------------|---------------|-------------------|------------------------|
| [Blank Box]       | SAND          | [Cross-hatch Box] | CLAYEY GRAVEL | [Dotted Box]      | NAVARRO CLAY           |
| [Dotted Box]      | GRAVEL        | [Cross-hatch Box] | CLAY          | [Dotted Box]      | TRANSITION ZONE (INT.) |
| [Cross-hatch Box] | FILL MATERIAL | [Cross-hatch Box] | CLAY (BLACK)  | [Cross-hatch Box] | NAVARRO CLAY (BROWN)   |
| [Cross-hatch Box] | CLAY (BROWN)  | [Cross-hatch Box] | CLAY          | [Cross-hatch Box] | CLAY                   |

SOURCE: HALIBURTON NUS, 1991  
26819-03, 10/23/92 at 07:49



Complex distribution patterns of TPH contamination were found southwest of the airplane. For example, F2S03, a surface-soil sample collected 50 feet southwest of the simulated airplane, contained 4,600 mg/kg TPH, whereas F2B03, located 20 feet northwest of F2S03, had a TPH concentration of only 9 mg/kg in soil samples from the 12- to 17-foot depth interval. However, well F205, located 40 feet south of F2S03 and sampled from 13 to 15 feet, contained 2,300 mg/kg TPH (Figure 2.2). These facts suggest that contamination is not spreading through the vadose zone as a "wetting front", but rather via complex and possibly discrete pathways.

### 3.0 PILOT TEST ACTIVITIES

The purpose of this section is to describe the pilot test activities to take place at Site S-4 and Site FC-2. The proposed locations and construction details for the central VWs and vapor MPs are discussed. Criteria for locating a suitable background well position are outlined. Soil and soil gas sampling procedures and the blower configuration that will be used to inject air (oxygen) into contaminated soils are also discussed in this section. Finally, a brief description of the pilot test procedures is provided.

The bioventing technology is intended to remediate contamination only in the unsaturated zone. Therefore, pilot test activities will be confined mainly to unsaturated soils. The central VWs may be completed to approximately 2 or 3 feet below the current groundwater table to provide oxygen to the deepest levels of the unsaturated zone, in case the groundwater table recedes due to pressurization or natural fluctuation. No dewatering will take place during the pilot tests. Existing monitoring wells will not be used as primary air injection or vapor monitoring wells. However, monitoring wells which have a portion of their screened interval above the water table may be used as vapor MPs or to measure the composition of background soil gas.

#### 3.1 Bioventing Test Design for Site S-4

A general description of criteria for siting a central VW and vapor MPs are included in the protocol document (Hinchee et al., 1992). Figure 3.1 illustrates the proposed locations of the central VW and MPs at this site. The final locations of these wells may vary slightly from the proposed locations if significant fuel contamination is not observed in the boring for the central VW. Soils in this area are expected to be TPH contaminated and oxygen depleted (< 2%), and biological activity should be stimulated by oxygen-rich soil gas ventilation during pilot test operations.

Due to the relatively shallow depth of contamination at this site and the potential for low permeability soils, the potential radius of venting influence around the central VW is expected to be 20 to 30 feet. Three vapor MPs (MPA, MPB, and MPC) will be located within a 30-foot radius of the central VW.

The VW will be constructed of 4-inch diameter Schedule 40 polyvinyl chloride (PVC), with a 10-foot interval of 0.04-inch slotted screen set at 7 to 17 feet bgs. Flush-threaded PVC casing and screen with no organic solvents or glues will be used. The filter pack will be clean, well-rounded silica sand with a 6-9 grain size and

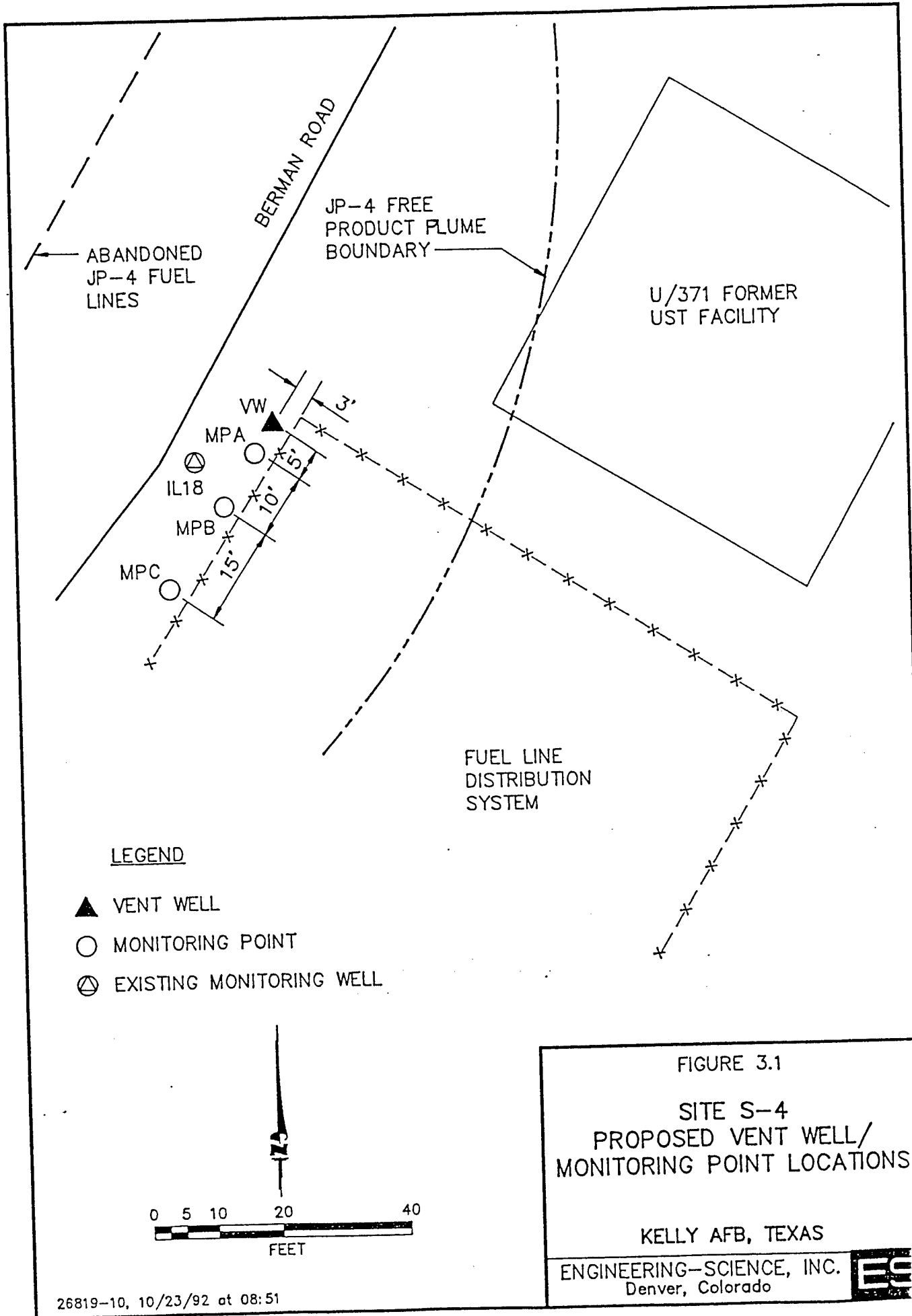

LEGEND

- ▲ VENT WELL
- MONITORING POINT
- ⊗ EXISTING MONITORING WELL

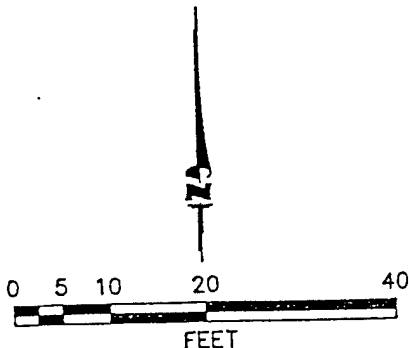



FIGURE 3.1  
 SITE S-4  
 PROPOSED VENT WELL/  
 MONITORING POINT LOCATIONS

KELLY AFB, TEXAS

ENGINEERING-SCIENCE, INC.  
 Denver, Colorado



will be placed in the annular space to one foot above the screened interval. A 5-foot layer of bentonite will be placed directly over the filter pack. The first 6 inches of bentonite will consist of bentonite pellets hydrated in place with potable water. This layer of pellets will prevent the addition of bentonite slurry from saturating the filter pack. The remaining 54 inches of bentonite will be fully hydrated and mixed aboveground, and the slurry will be tremmied into the annular space to produce an air-tight seal above the screened interval. The borehole will then be completed to the ground surface with a bentonite/cement grout. A complete seal is critical to prevent injected air from short-circuiting to the surface during the bioventing test. Figure 3.2 illustrates the proposed central VW construction detail for this site.

A typical multi-depth vapor MP installation for this site is shown in Figure 3.3. Soil gas oxygen and carbon dioxide concentrations will be monitored at depths of 7 feet, 10 feet, and 14 feet at each location. Multi-depth monitoring will confirm that the entire soil profile is receiving oxygen and be used to measure fuel biodegradation rates at the three depths. The annular spaces between the three screened MP intervals will be sealed with bentonite to isolate the monitoring intervals. As with the central VW, several inches of bentonite pellets will be used to shield the filter pack from rapid infiltration of bentonite slurry additions. Additional details on VW and MP construction are presented in Section 4 of the protocol document (Hinchee et al., 1992).

### 3.2 Site FC-2

Figure 3.4 illustrates the proposed locations of the central VW and MPs at this site. The final location of these wells may vary slightly from the proposed location if significant fuel contamination is not observed in the boring for the central VW. Based on site investigation data, the central VW should be located southwest of the simulated airplane, near monitoring well F205. This area is expected to have an average TPH concentration exceeding 1,000 mg/kg. Soils in this area are expected to be oxygen depleted (<2%), and biological activity should be stimulated by oxygen-rich soil gas ventilation during pilot test operations.

Due to the relatively shallow depth of contamination at this site and the potential for low permeability soils, the potential radius of influence around the central VW is expected to be 30 to 40 feet. Three vapor MPs (MPA, MPB, and MPC) will be located within a 40 feet radius of the central VW.

The VW will be constructed of 4-inch diameter Schedule 40 PVC, with a 12-foot interval of 0.04-inch slotted screen set at 7 to 19 feet bgs. Flush-threaded PVC casing and screen with no organic solvents or glues will be used. The filter pack will be clean, well-rounded silica sand with a 6-9 grain size and will be placed in the annular space to one foot above the screened interval. A 5-foot layer of bentonite will be placed directly over the filter pack. The first 6 inches of bentonite will consist of bentonite pellets hydrated in place with potable water. This layer of pellets will prevent the rapid addition of bentonite slurry from saturating the upper portion of the filter pack. The remaining 54 inches of bentonite will be fully hydrated and mixed aboveground, and then tremmied into the annular space to produce an air-tight seal above the screened interval. A complete seal is critical to

2" DIAMETER SCH 40  
PVC HEADER SLOPED  
TO WELL

← FROM BLOWER

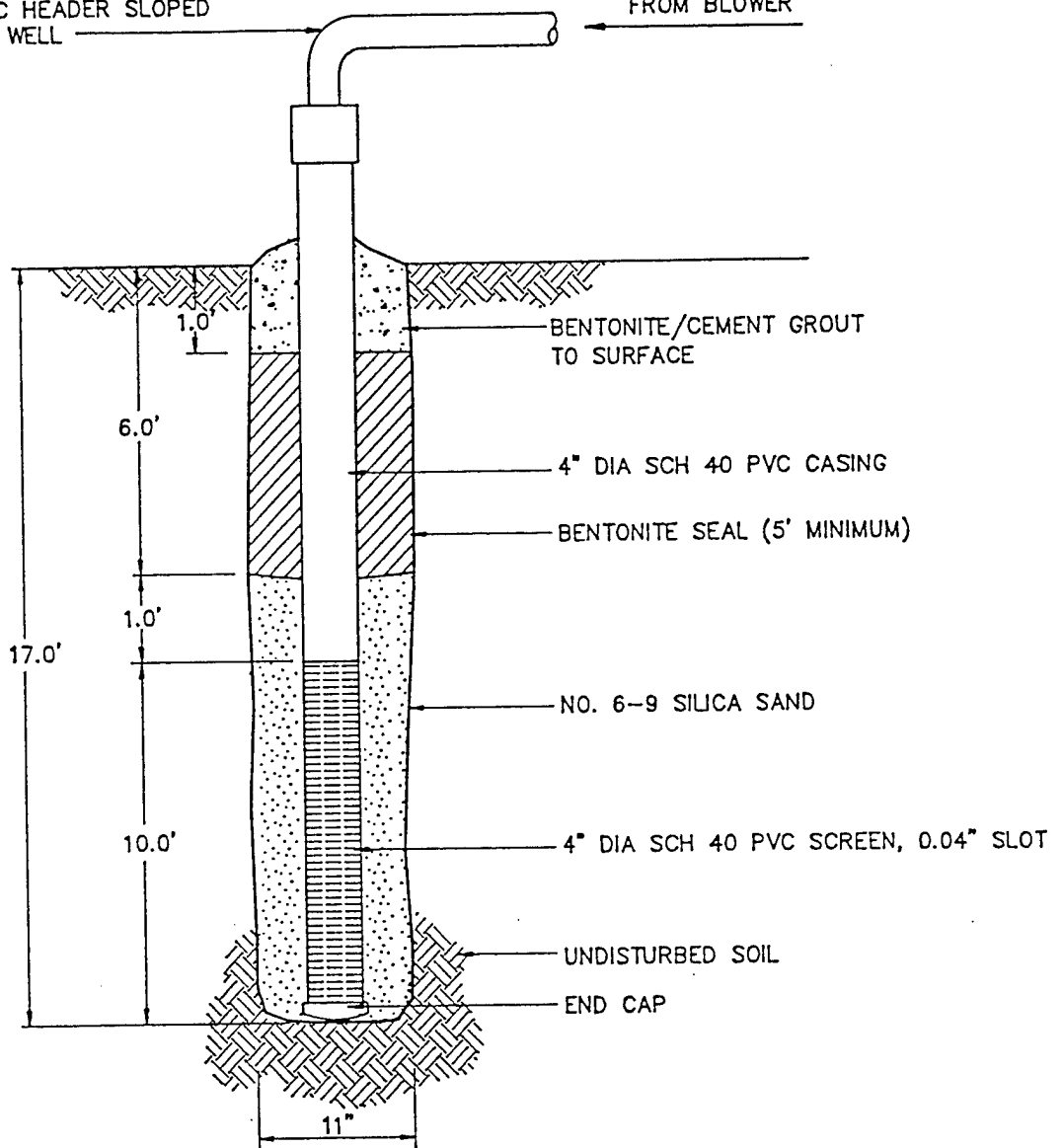

NOT TO SCALE

FIGURE 3.2  
SITE S-4  
INJECTION VENT WELL  
CONSTRUCTION DETAIL

KELLY AFB, TEXAS

ENGINEERING-SCIENCE, INC.  
Denver, Colorado



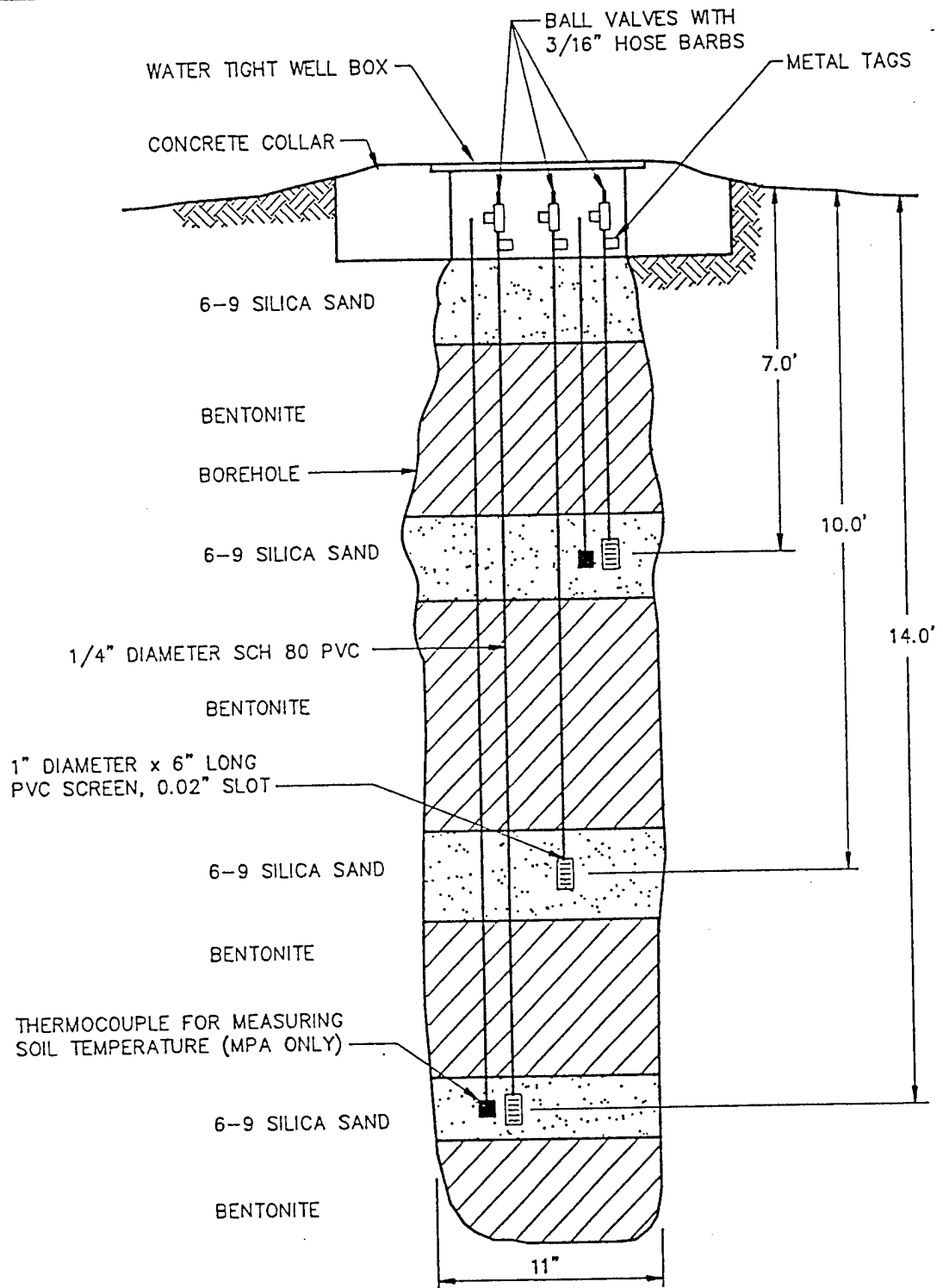

FIGURE 3.3

SITE S-4  
 MONITORING POINT  
 CONSTRUCTION DETAIL

KELLY AFB, TEXAS

ENGINEERING-SCIENCE, INC.  
 Denver, Colorado



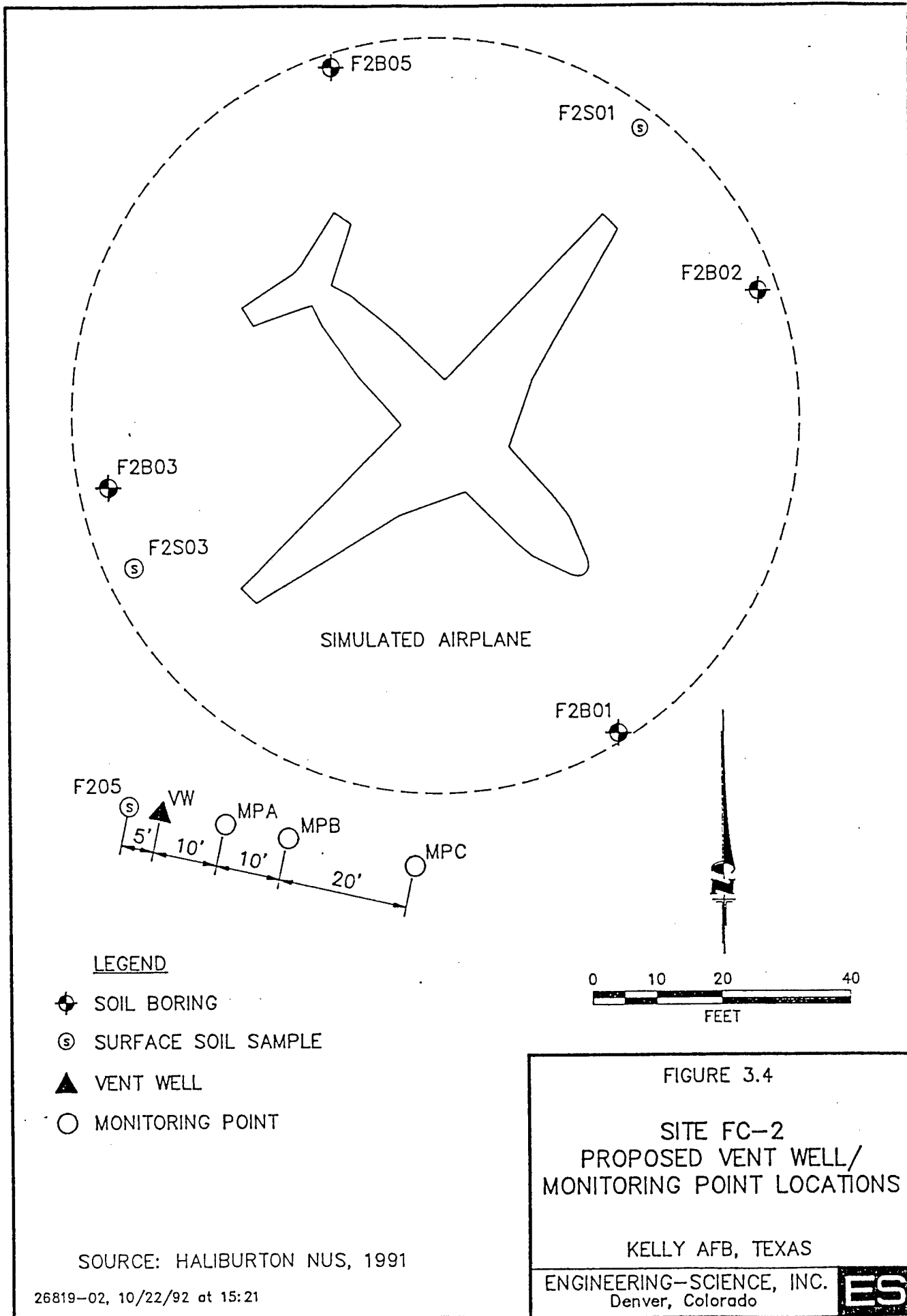

LEGEND

- ⊕ SOIL BORING
- ⊙ SURFACE SOIL SAMPLE
- ▲ VENT WELL
- MONITORING POINT

SOURCE: HALIBURTON NUS, 1991

26819-02, 10/22/92 at 15:21

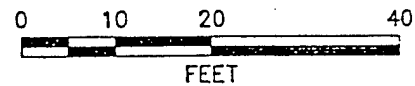

FIGURE 3.4

SITE FC-2  
PROPOSED VENT WELL/  
MONITORING POINT LOCATIONS

KELLY AFB, TEXAS

ENGINEERING-SCIENCE, INC.  
Denver, Colorado



prevent injected air from short-circuiting to the surface during the bioventing test. The well will be completed to the ground surface with a bentonite/cement grout. Figure 3.5 illustrates the proposed central vent well construction for this site.

A typical multi-depth vapor MP installation design for this site is shown in Figure 3.6. Soil gas oxygen and carbon dioxide concentrations will be monitored at depth intervals of 4 feet, 11 feet, and 16 feet at each location. Multi-depth monitoring will confirm that the entire soil profile is receiving oxygen, and will be used to measure fuel biodegradation rates at each depth. The annular spaces between the three monitoring intervals in each MP will be sealed with bentonite to isolate the intervals. As in the central VW, several inches of bentonite pellets will be used to shield the filter pack from rapid infiltration of bentonite slurry additions. Additional details on VW and MP construction are provided in Section 4 of the protocol document.

### 3.3 Background Well

The construction of an additional vapor MP may be required to measure background levels of oxygen and carbon dioxide and to determine if natural carbon sources are contributing to oxygen uptake during the *in situ* respiration test described in Section 3.7. This background well would be installed in an area of uncontaminated soil and in the same stratigraphic formation as the MPs to be installed at Site S-4 and FC-2. The background well would be similar in construction to the MPs (Figures 3.3 and 3.6), and would be screened at 2 or more depths. ES will require some assistance from Kelly AFB in locating an appropriate position for the proposed background well.

Existing groundwater monitoring wells located in areas with no fuel contamination may be suitable for use as background wells. These wells must have a portion of their screened interval above the water table, and initial soil gas samples must contain oxygen in excess of 15 percent to be used as background wells. Additional information regarding background wells may be found in Section 4.3 of the protocol document (Hinchee et al., 1992).

### 3.4 Handling of Drill Cuttings

Drill cuttings from all VW and MP borings will be collected in U.S. Department of Transportation (DOT) approved containers. The containers will be labeled and placed in the Kelly AFB hazardous materials storage area. These drill cuttings will become the responsibility of Kelly AFB, and will be analyzed, handled, and disposed of in accordance with the current procedures for ongoing remedial investigations. This project is expected to generate less than two 55-gallon drums of cuttings.

2" DIAMETER SCH 40  
PVC HEADER SLOPED  
TO WELL

FROM BLOWER

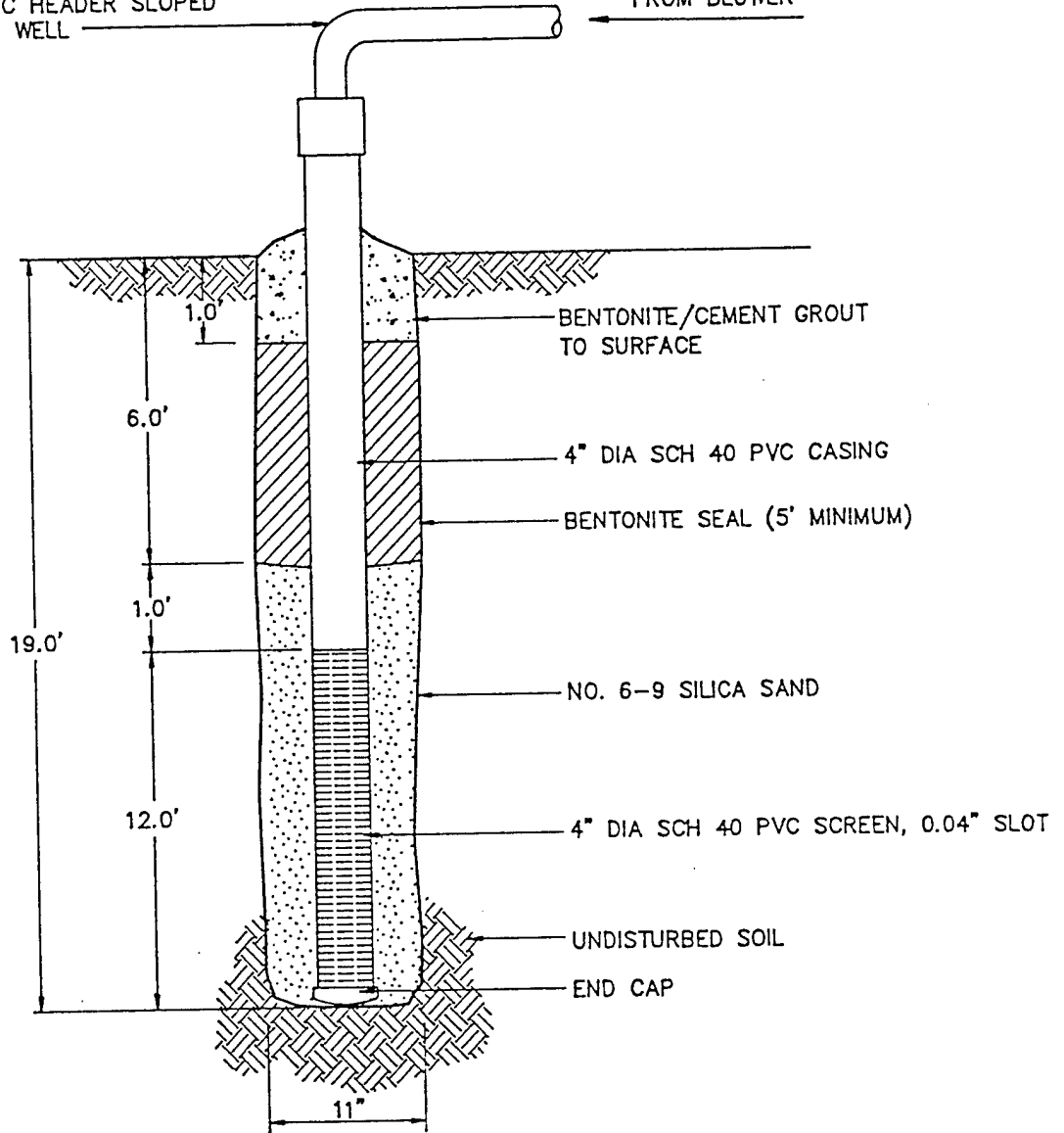

NOT TO SCALE

FIGURE 3.5  
SITE FC-2  
INJECTION VENT WELL  
CONSTRUCTION DETAIL

KELLY AFB, TEXAS

ENGINEERING-SCIENCE, INC.  
Denver, Colorado



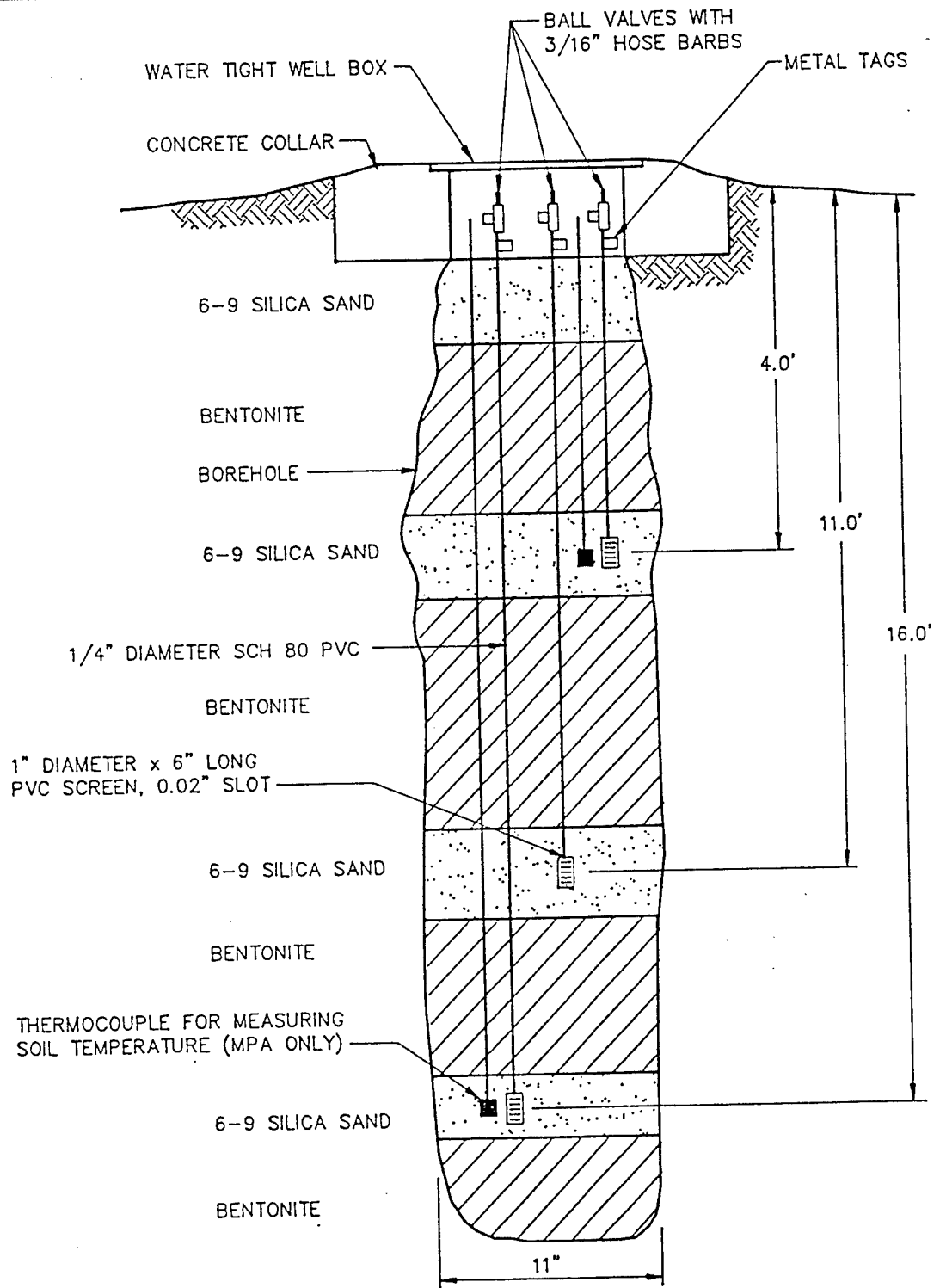

FIGURE 3.6  
 SITE FC-2  
 MONITORING POINT  
 CONSTRUCTION DETAIL

KELLY AFB, TEXAS

ENGINEERING-SCIENCE, INC.  
 Denver, Colorado



### 3.5 Soil and Soil Gas Sampling

#### 3.5.1 Soil Samples

Three soil samples will be collected from each pilot test area during the installation of the VW and MPs. Sampling procedures will follow those outlined in the protocol document. One sample will be collected from the most contaminated interval of each VW boring, and one sample will be collected from the interval of highest apparent contamination in each of the borings for the two MPs closest to the VW. Soil samples will be analyzed for total recoverable petroleum hydrocarbons (TRPH), BTEX, soil moisture, pH, particle sizing, alkalinity, total iron, and nutrients.

Samples for TRPH and BTEX analysis will be collected using a split-spoon sampler containing brass tube liners. Soil samples collected in the brass tubes for TRPH and BTEX analyses will be immediately trimmed, and the ends will be sealed with aluminum foil or Teflon® fabric held in place by plastic caps. Soil samples collected for physical parameter analyses will be placed in glass sample jars or other appropriate sample containers specified in the base sample handling plan. Soil samples will be labelled following the nomenclature specified in the protocol document (Section 5), wrapped in plastic, and placed in a cooler maintained at a temperature of 4 degrees centigrade for shipment. A chain-of-custody form will be filled out, and the cooler will be shipped to the ES laboratory in Berkeley, California, for analysis. This laboratory has been audited by the Air Force and meets all quality assurance/quality control and certification requirements for the State of California.

#### 3.5.2 Soil Gas Samples

A total hydrocarbon vapor analyzer will be used during augering to screen split-spoon soil samples for intervals of high fuel contamination. Initial and final soil gas samples will be collected in SUMMA® canisters in accordance with the Bioventing Field Sampling Plan (Engineering-Science, Inc., 1992) from the VW and from the MPs closest to and furthest from the VW. Additionally, these soil gas samples will be used to predict potential air emissions, to determine the reduction in BTEX and total volatile hydrocarbons (TVH) during the 1-year test, and to detect any migration of these vapors from the source area.

Soil gas sample canisters will be placed in a small cooler and packed with foam pellets to prevent excessive movement during shipment. Samples will not be sent on ice to prevent condensation of hydrocarbons. A chain-of-custody form will be filled out, and the cooler will be shipped to the Air Toxics laboratory in Rancho Cordova, California for analysis.

### 3.6 Blower System

A 2.5-horsepower positive-displacement blower capable of injecting air at a flow rate of 20 to 40 standard cubic feet per minute (scfm) at a pressure of 8 pounds per square inch will be used to conduct the initial air permeability tests and *in situ* respiration tests. Figure 3.7 is a schematic of a typical air injection system used for pilot testing. The maximum power requirement anticipated for this pilot test is a

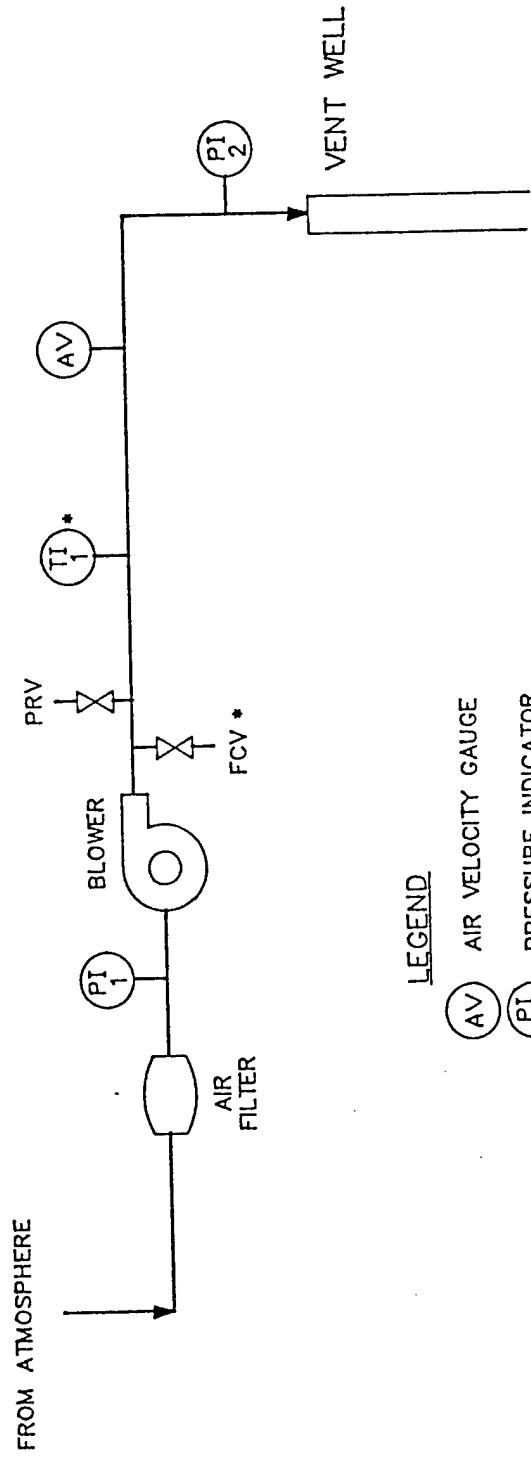

LEGEND

- (AV) AIR VELOCITY GAUGE
- (PI 1) PRESSURE INDICATOR
- (TI 1) TEMPERATURE INDICATOR
- FCV FLOW CONTROL VALVE
- PRV PRESSURE RELIEF VALVE
- \* OPTIONAL

FIGURE 3.7  
 BLOWER SYSTEM  
 INSTRUMENTATION DIAGRAM  
 FOR AIR INJECTION

KELLY AFB, TEXAS

ENGINEERING—SCIENCE, INC.  
 Denver, Colorado

**ES**

230-volt, single-phase, 30-amp service. Additional details on power supply requirements are described in Section 5.0, Base Support Requirements.

### 3.7 In Situ Respiration Tests

The objective of the *in situ* respiration tests is to determine the rate at which soil bacteria degrade petroleum hydrocarbons. Respiration tests will be performed at every vapor MP where bacterial biodegradation of hydrocarbons is indicated by low oxygen levels and elevated carbon dioxide concentrations in the soil gas. Using a 1 scfm pump, air will be injected into each MP depth interval containing low levels (<2%) of oxygen. A 20-hour air injection period will be used to oxygenate local contaminated soils. At the end of the 20-hour air injection period, the air supply will be cut off, and oxygen and carbon dioxide levels will be monitored for the following 48 to 72 hours. The decline in oxygen and increase in carbon dioxide concentrations over time will be used to estimate rates of bacterial degradation of fuel residuals. Helium will also be injected at one or two MPs to estimate oxygen diffusion rates in site soils. This estimated rate of diffusion will be used to separate oxygen diffusion and biodegradation components of the measured rate of oxygen consumption. Additional details on the *in situ* respiration test procedures are provided in Section 5.7 of the protocol document (Hinchee et al., 1992).

### 3.8 Air Permeability Tests

The objective of the air permeability tests is to determine the extent of the subsurface that can be oxygenated using the VW. Air will be injected into the 4-inch-diameter VW using the blower unit, and pressure response will be measured at each MP with differential pressure gauges to determine the region influenced by the unit. Oxygen will also be monitored in the MPs to ascertain whether oxygen levels in the soil increase as the result of air injection. One air permeability test lasting 4 to 8 hours will be performed at each site.

### 3.9 Extended Pilot Test Bioventing System

Extended, 1-year bioventing systems will also be installed at Site S-4 and Site FC-2. At each site, the base will be requested to provide a power pole with a 230-volt, single-phase, 30-amp breaker box, one 230-volt receptacle, and two 115-volt receptacles. Depending on the availability of a base electrician, a base electrician or a licensed electrician subcontracted to ES will assist in wiring the blowers to line power. The blowers will be housed in small, prefabricated sheds to provide protection from the weather.

The systems will be in operation for 1 year, and every 6 months ES personnel will conduct *in situ* respiration tests to monitor the long-term performance of this bioventing system. Weekly system checks will be performed by Kelly AFB personnel. If required, major maintenance of the blower unit may be performed by ES-San Antonio personnel. Detailed blower system information and a maintenance schedule will be included in the operation and maintenance (O&M) manual provided to the base. More detailed information regarding the test procedures can be found in the protocol document.

#### 4.0 EXCEPTIONS TO PROTOCOL PROCEDURES

The procedures that will be used to measure the air permeability of the soil and *in situ* respiration rates are described in Sections 4 and 5 of the protocol document (Hinchee et al., 1992). No exceptions to the protocol procedures are anticipated.

#### 5.0 BASE SUPPORT REQUIREMENTS

The following base support is needed prior to the arrival of the drilling subcontractor and the ES pilot test team:

- Assistance in obtaining drilling and digging permits.
- Assistance in finding a suitable location for the background well. The background well location should be in an area with no fuel contamination and with similar stratigraphy to that of Site S-4 and Site FC-2. Preferably, 110-volt receptacle power will be available within 150 feet of the background well location.
- Installation of power poles at Site S-4 and Site FC-2. Each pole should include a 230-volt, 30-amp, single-phase service and a breaker box with one 230-volt receptacle and two 115-volt receptacles. The poles should be located within 10 to 15 feet of the central VW location at each site.
- Provision of any paperwork required to obtain gate passes and security badges for approximately three ES employees, two drillers, and an electrician (if a base electrician is not available). Vehicle passes will be needed for one truck and a drill rig.

During the initial testing, the following base support is needed:

- A decontamination pad where the driller can clean augers between borings.
- Acceptance of responsibility by Kelly AFB for drill cuttings from VW and MP borings, including any drum sampling to determine hazardous waste status.
- Twelve square feet of desk space and a telephone in a building located as close to the site as practicable.
- The use of a facsimile machine for transmitting 15 to 20 pages of test results.

During the 1-year extended pilot test, base personnel will be required to perform the following activities:

- Check the blower system once per week to ensure that it is operating and to record the air-injection pressure and temperature. Change air filters and blower lubricants when required. ES will provide a brief training session on these procedures and an O&M manual.
- If the blower stops working, notify Mr. John Ratz or Mr. Doug Downey, ES-Denver, at (303) 831-8100, or Mr. Jerry Hansen, AFCEE, at (512) 536-4331.
- Arrange site access for an ES technician to conduct *in situ* respiration tests approximately 6 months and 1 year after the initial pilot test.

## 6.0 PROJECT SCHEDULE

The following schedule is contingent upon timely approval of this pilot test work plan.

| <u>Event</u>                            | <u>Date</u>      |
|---|------------------|
| Draft Test Work Plan to AFCEE/Kelly AFB | 28 October 1992  |
| Notice to Proceed                       | 11 November 1992 |
| Begin Initial Pilot Tests               | 7 December 1992  |
| Complete Initial Pilot Tests            | 22 December 1992 |
| Interim Results Report                  | 1 February 1993  |
| Second Respiration Tests                | June 1993        |
| Final Respiration Tests                 | December 1993    |
| Final Results Report                    | January 1994     |

## 7.0 POINTS OF CONTACT

Mr. Dennis Guadarrama/Mr. Bill Bright/Mr. Stephen Escude  
SA-ALC/EMR  
Bldg. 306, 307 Tinker Drive  
Kelly AFB, TX 78241-5000  
(512) 925-3100 ext. 297, 252, 333

Major Ross Miller/Mr. Jerry Hansen  
AFCEE/ESR  
Brooks AFB, TX 78235-5000  
(512) 536-4331

Mr. Doug Downey  
Engineering-Science, Inc.  
1700 Broadway, Suite 900  
Denver, CO. 80290  
(303) 831-8100  
Fax (303) 831-8208

## 8.0 REFERENCES

- Engineering-Science, Inc. 1992. *Field Sampling Plan for AFCEE Bioventing*.  
January.
- Haliburton NUS. 1991. *Zone 2 Remedial Investigation Report*.
- Hinchee, R.E., S.K. Ong, R.N. Miller, D.C. Downey, and R. Frandt. January 1992.  
*Test Plan and Technical Protocol for a Field Treatability Test for Bioventing*.
- NUS. 1990. *Contamination Source Evaluation Report*.

**PART II**  
**DRAFT**  
**INTERIM PILOT TEST RESULTS REPORT**  
**SITE S-4 AND SITE FC-2**  
**KELLY AFB, TEXAS**

**Prepared for:**  
**Air Force Center for Environmental Excellence**  
**Brooks AFB, Texas**  
**and**  
**San Antonio Air Logistics Center/EMR**  
**Kelly AFB, Texas**

**February 1993**

**Prepared by:**  
**Engineering-Science, Inc.**  
**1700 Broadway, Suite 900**  
**Denver, Colorado 80290**

## CONTENTS

### PART II - DRAFT INTERIM PILOT TEST RESULTS REPORT FOR SITE S-4 AND SITE FC-2 KELLY AFB, TEXAS

|   | <u>Page</u> |
|---|-------------|
| 1.0 Site S-4 .....                                      | II-1        |
| 1.1 Pilot Test Design and Construction .....            | II-1        |
| 1.1.1 Air Injection Vent Well .....                     | II-1        |
| 1.1.2 Monitoring Points .....                           | II-5        |
| 1.1.3 Blower Unit .....                                 | II-5        |
| 1.2 Pilot Test Soil and Soil Gas Sampling Results ..... | II-5        |
| 1.2.1 Sampling Results .....                            | II-5        |
| 1.2.2 Exceptions to Test Protocol Procedures .....      | II-8        |
| 1.3 Pilot Test Results .....                            | II-8        |
| 1.3.1 Initial Soil Gas Chemistry .....                  | II-8        |
| 1.3.2 Air Permeability .....                            | II-11       |
| 1.3.3 Oxygen Influence .....                            | II-11       |
| 1.3.4 <i>In Situ</i> Respiration Rates .....            | II-11       |
| 1.3.5 Potential Air Emissions .....                     | II-23       |
| 1.4 Recommendations .....                               | II-23       |
| 2.0 Site FC-2 .....                                     | II-24       |
| 2.1 Pilot Test Design and Construction .....            | II-24       |
| 2.1.1 Air Injection Vent Well .....                     | II-24       |
| 2.1.2 Monitoring Points .....                           | II-24       |
| 2.1.3 Blower Unit .....                                 | II-28       |
| 2.2 Pilot Test Soil and Soil Gas Sampling Results ..... | II-28       |
| 2.2.1 Sampling Results .....                            | II-28       |
| 2.2.2 Exceptions to Test Protocol Procedures .....      | II-31       |
| 2.3 Pilot Test Results .....                            | II-31       |
| 2.3.1 Initial Soil Gas Chemistry .....                  | II-31       |
| 2.3.2 Air Permeability .....                            | II-31       |
| 2.3.3 Oxygen Influence .....                            | II-35       |
| 2.3.4 <i>In Situ</i> Respiration Rates .....            | II-35       |
| 2.3.5 Potential Air Emissions .....                     | II-43       |
| 2.4 Recommendations .....                               | II-43       |
| 3.0 References .....                                    | II-44       |

APPENDIX A O&M Instructions

APPENDIX B Geologic Boring Logs and Chain-of-Custody Forms

## CONTENTS (Continued)

### TABLES

| <u>No.</u>        | <u>Title</u>   | <u>Page</u> |
|-------------------|--|-------------|
| <u>Site S-4:</u>  |  |             |
| 1.1               | Soil and Soil Gas Analytical Results .....   | II-9        |
| 1.2               | Initial Soil Gas Chemistry .....   | II-10       |
| 1.3               | Pressure Response During the Air Permeability Test .....                           | II-12       |
| 1.4               | Influence of Air Injection at Vent Well on<br>Monitoring Point Oxygen Levels ..... | II-13       |
| 1.5               | Oxygen Utilization Rates.....  | II-22       |
| <u>Site FC-2:</u> |  |             |
| 2.1               | Soil and Soil Gas Analytical Results .....   | II-32       |
| 2.2               | Initial Soil Gas Chemistry .....   | II-33       |
| 2.3               | Pressure Response During the Air Permeability Test .....                           | II-34       |
| 2.4               | Influence of Air Injection at Vent Well on<br>Monitoring Point Oxygen Levels ..... | II-36       |
| 2.5               | Oxygen Utilization Rates.....  | II-42       |

### FIGURES

| <u>No.</u>        | <u>Title</u>   | <u>Page</u> |
|-------------------|--|-------------|
| <u>Site S-4:</u>  |  |             |
| 1.1               | As-Built Site Plan.....  | II-2        |
| 1.2               | Hydrogeologic Cross Section .....                                      | II-3        |
| 1.3               | As-Built Injection Vent Well Construction Detail .....                 | II-4        |
| 1.4               | As-Built Monitoring Point Construction Detail.....                     | II-6        |
| 1.5               | As-Built Blower System for Air Injection.....                          | II-7        |
| 1.6               | Respiration Test, Vent Well.....                                       | II-15       |
| 1.7               | Respiration Test, MPA-12.5.....  | II-16       |
| 1.8               | Respiration Test, MPB-9.....   | II-17       |
| 1.9               | Respiration Test, MPB-12.5.....  | II-18       |
| 1.10              | Respiration Test, MPC-12.5.....  | II-19       |
| 1.11              | Respiration Test, Oxygen and Helium<br>Concentrations, MPA-12.5 .....  | II-20       |
| 1.12              | Respiration Test, Oxygen and Helium<br>Concentrations, Vent Well ..... | II-21       |
| <u>Site FC-2:</u> |  |             |
| 2.1               | As-Built Site Plan.....  | II-25       |
| 2.2               | Hydrogeologic Cross Section .....                                      | II-26       |
| 2.3               | As-Built Injection Vent Well Construction Detail .....                 | II-27       |
| 2.4               | As-Built Monitoring Point Construction Detail .....                    | II-29       |
| 2.5               | As-Built Blower System for Air Injection .....                         | II-30       |
| 2.6               | Respiration Test, MPA-13.5.....  | II-37       |
| 2.7               | Respiration Test, MPB-9.....   | II-38       |
| 2.8               | Respiration Test, MPB-13.5.....  | II-39       |
| 2.9               | Respiration Test, MPC-13.5.....  | II-40       |
| 2.10              | Respiration Test, Oxygen and Helium<br>Concentrations, MPA-13.5 .....  | II-41       |

**PART II**  
**DRAFT**  
**INTERIM PILOT TEST RESULTS REPORT**  
**SITE S-4 AND SITE FC-2**  
**KELLY AFB, TEXAS**

Initial bioventing pilot tests were completed at Site S-4 and Site FC-2 at Kelly Air Force Base (AFB), Texas during the period of 7 through 22 December 1992. The purpose of this Part II report is to describe the results of the initial pilot tests at Site S-4 and Site FC-2 and to make specific recommendations for extended testing to determine the long-term impact of bioventing on site contaminants. Descriptions of the history, geology, and contamination at each site are contained in Part I, the Bioventing Pilot Test Work Plan.

**1.0 SITE S-4**

**1.1 Pilot Test Design and Construction**

Installation of an air injection vent well (VW) and three vapor monitoring points (MPs) at Site S-4 began on 10 December 1992, and was completed on 11 December 1992. Drilling services were provided by Jones Environmental Drilling, Inc., of Corpus Christi, Texas. Well installation and soil sampling were directed by Mr. John Ratz, the Engineering-Science, Inc. (ES) site manager, and Mr. John Pawlik, the ES site geologist. The following sections describe the final design and installation of the bioventing system at this site.

One VW, three MPs (MPA, MPB, and MPC), and a blower unit were installed at Site S-4. Figures 1.1 and 1.2, respectively, depict the locations of and hydrogeologic cross sections for the VW and MPs completed at Site S-4. A background MP was not installed at Site S-4 because there were no areas of uncontaminated soil at the site accessible for drilling. Therefore, data from the background MP installed at Site FC-2 was also applied to Site S-4.

**1.1.1 Air Injection Vent Well**

The air injection VW was installed following procedures described in the Air Force Center for Environmental Excellence (AFCEE) bioventing protocol document (Hinchee et al., 1992). Figure 1.3 shows construction details for the VW. The VW was installed in gravelly clay that contained hydrocarbon contamination at all sampling locations. Groundwater was encountered at 13.5 feet below ground

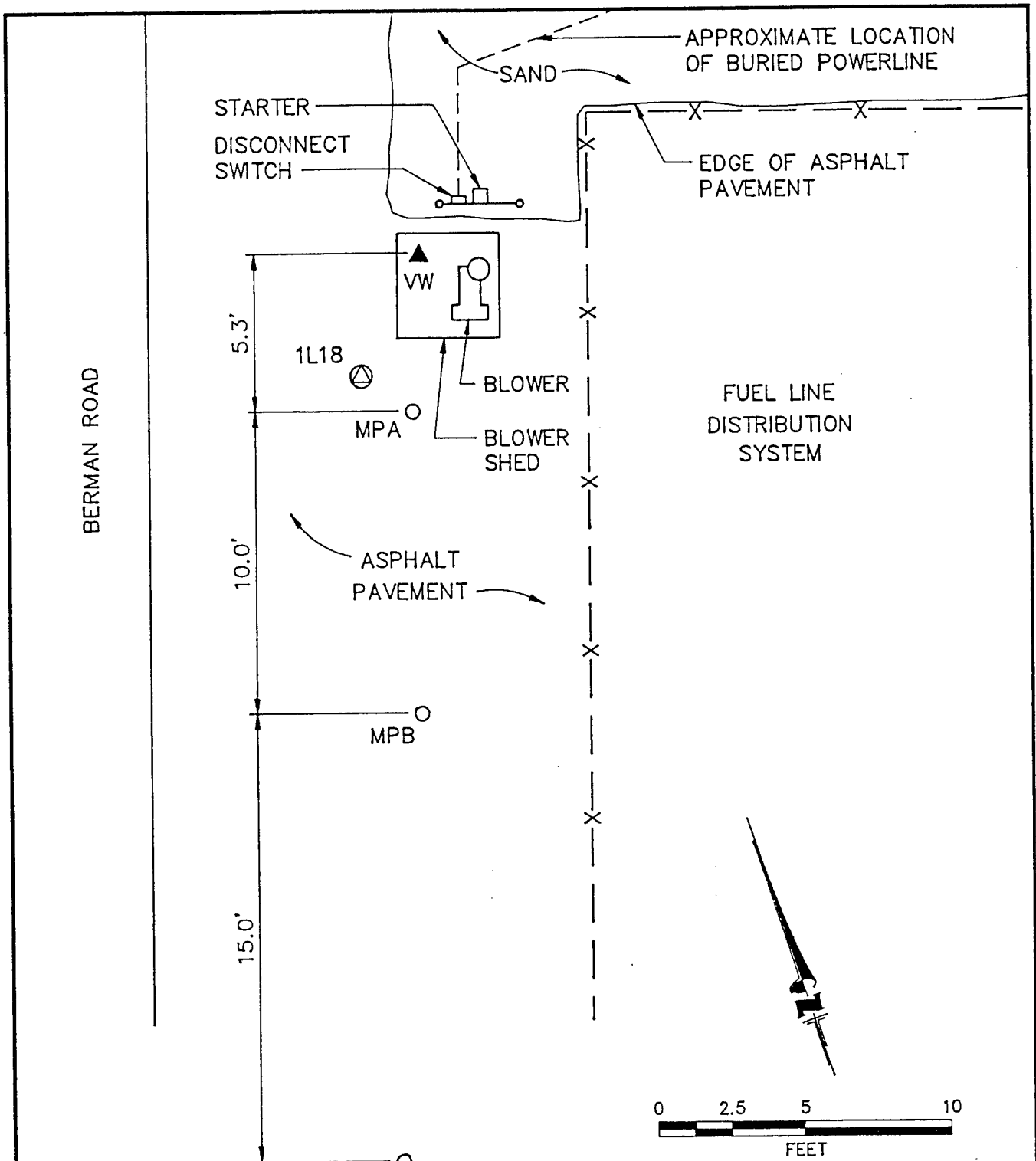

**LEGEND**

- VW ▲ INJECTION VENT WELL
- MPA ○ MONITORING POINT
- ⊗ EXISTING GROUNDWATER MONITORING WELL
- X— FENCE

FIGURE 1.1

**SITE S-4  
AS-BUILT SITE PLAN**

KELLY AFB, TEXAS

ENGINEERING-SCIENCE, INC.  
Denver, Colorado



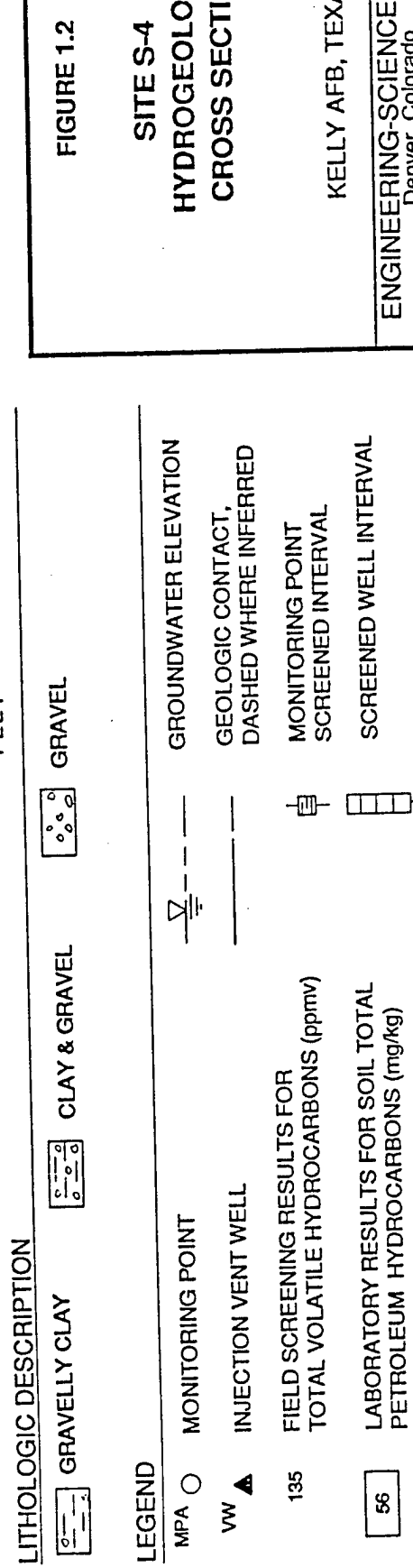
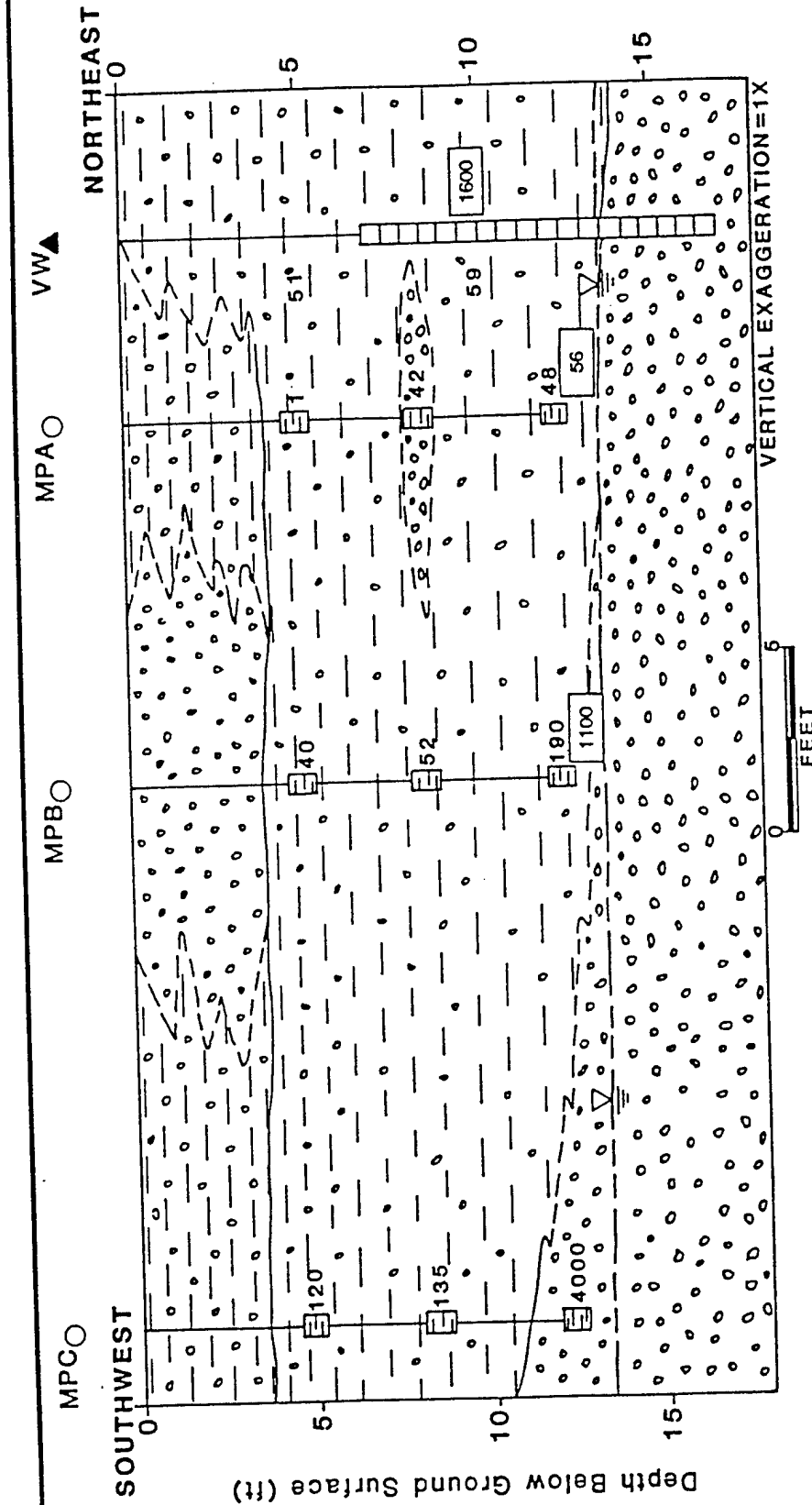

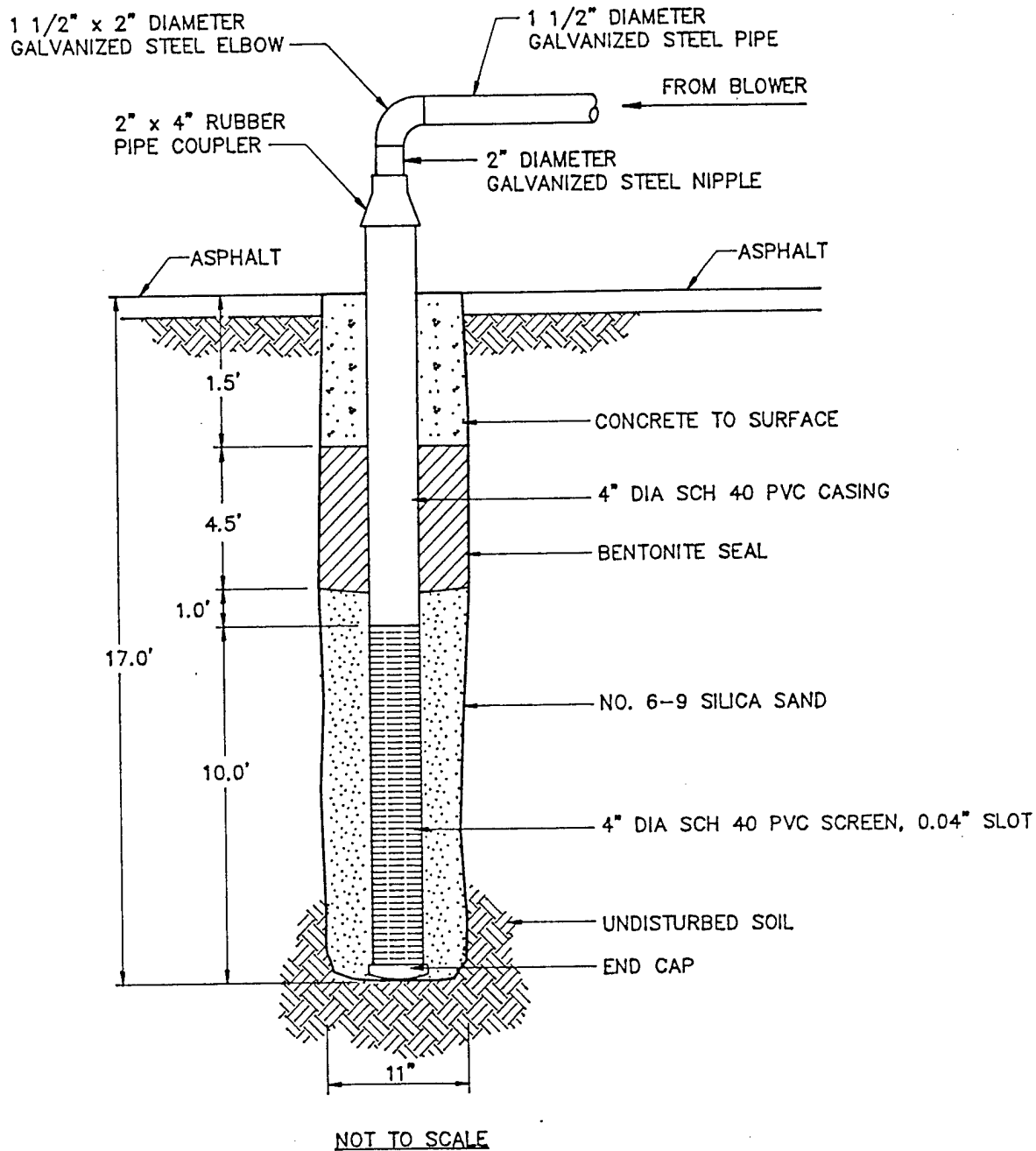

FIGURE 1.3  
 SITE S-4  
 AS-BUILT INJECTION VENT WELL  
 CONSTRUCTION DETAIL

KELLY AFB, TEXAS

ENGINEERING-SCIENCE, INC.  
 Denver, Colorado



surface (bgs). The VW was constructed using 4-inch-diameter, Schedule 40 polyvinyl chloride (PVC) casing, with 10 feet of 0.04-inch slotted PVC screen installed from 7 to 17 feet bgs. The annular space between the well casing and borehole was filled with 6-9 silica sand from the bottom of the borehole to approximately 1 foot above the well screen. Approximately 4.5 feet of granular bentonite was placed above the sand in 6-inch lifts, with each lift being hydrated in place. On top of the bentonite layer, approximately 1.5 feet of concrete was placed and was finished flush with the existing asphalt surface. The well casing was cut off approximately 6 inches above the surface, and the casing was connected to a galvanized steel header using a rubber pipe coupler.

### **1.1.2 Monitoring Points**

At Site S-4, the MP screens were installed at 5.25-, 8.75-, and 12.25-foot depths. The three MPs (MPA, MPB, and MPC) were constructed as shown in Figures 1.2 and 1.4. Each MP monitoring interval was constructed using a 6-inch section of 1-inch-diameter PVC well screen and a 0.25-inch-diameter schedule 80 PVC riser pipe extending to the ground surface. At the top of each riser, a ball valve and a 3/16-inch hose barb were installed. The top of each MP was completed with a flush-mounted metal well protector set in a concrete base. Thermocouples were installed at the 5.25- and 12.25-foot depths at MPA to measure soil temperature variations. The existing groundwater monitoring well IL18 (Figure 1.1) could not be used as a soil gas MP because the entire length of the screened interval was below the groundwater/free product surface.

### **1.1.3 Blower Unit**

During the initial pilot test, a portable 3-horsepower Roots® 22U-RAI positive-displacement blower unit was used. A 1-horsepower Gast® R4110-50 regenerative blower unit was installed at Site S-4 and connected to the air injection VW for the extended pilot test. The fixed unit is energized by 240-volt, single-phase, 30-amp line power from a newly installed underground power line and aboveground breaker provided by the base. The configuration, instrumentation, and specifications for this blower system are shown on Figure 1.5. The blower is currently transporting air at a flow rate of approximately 68 actual cubic feet per minute (acfm) for the extended pilot test. A portion of this flow is being bled off through the gate valve. After blower installation and startup, ES engineers provided an operation and maintenance (O&M) manual, including maintenance instructions, equipment specifications, and monitoring forms to base personnel. A copy of the O&M instructions is provided in Appendix A.

## **1.2 PILOT TEST SOIL AND SOIL GAS SAMPLING RESULTS**

### **1.2.1 Sampling Results**

Soils at this site primarily consist of gravelly clay with some interbedded limestone gravel and silt. Groundwater was encountered at a depth of approximately 13.5 feet bgs in the VW, and approximately 1 foot of free product was measured on the ground water surface. More detailed hydrogeologic information

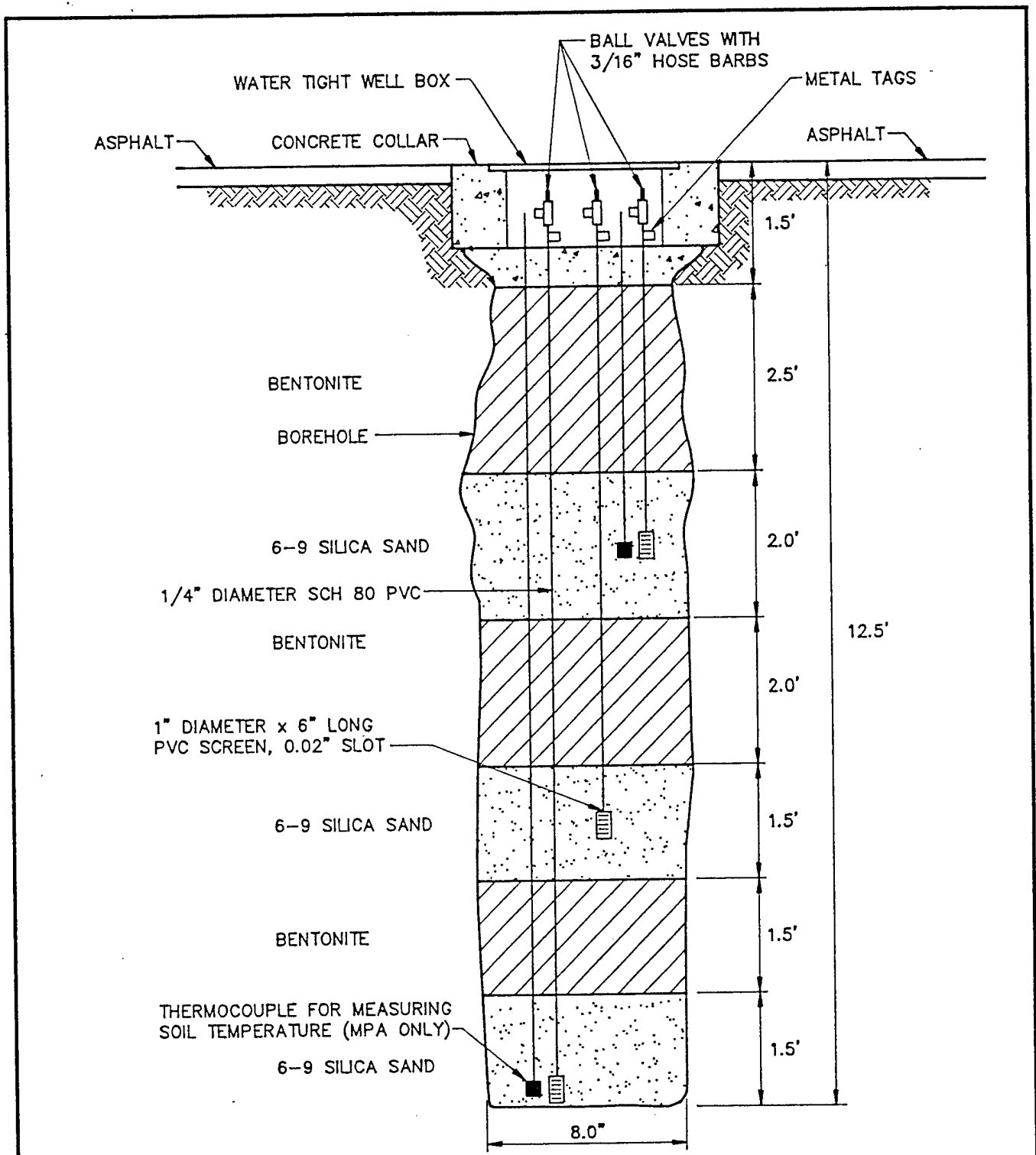

FIGURE 1.4  
 SITE S-4  
 AS-BUILT MONITORING POINT  
 CONSTRUCTION DETAIL  
 KELLY AFB, TEXAS  
 ENGINEERING-SCIENCE, INC.  
 Denver, Colorado

LEGEND

- ① INLET AIR FILTER - SOLBERG<sup>®</sup> AJ134E
- ② VACUUM GAUGE (0-60 in H<sub>2</sub>O)
- ③ BLOWER - GAST<sup>®</sup> 1HP R4110-50
- ④ PRESSURE GAUGE (0-100 in H<sub>2</sub>O)
- ⑤ AUTOMATIC PRESSURE RELIEF VALVE, SET TO RELEASE AT 58 IN H<sub>2</sub>O PRESSURE
- ⑥ TEMPERATURE GAUGE (0-250 °F)
- ⑦ MANUAL PRESSURE RELIEF (BLEED) VALVE - 1 1/2" GATE
- ⑧ STARTER - FURNAS<sup>®</sup> 14CSD33DA NEMA 3, NO START/STOP, OVERLOAD SET AT 6 AMPS
- ⑨ DISCONNECT SWITCH - 240V/SINGLE PHASE/30 AMP, FUSED DISCONNECT (GENERAL DUTY)
- ⑩ BREAKER BOX - 30 AMP

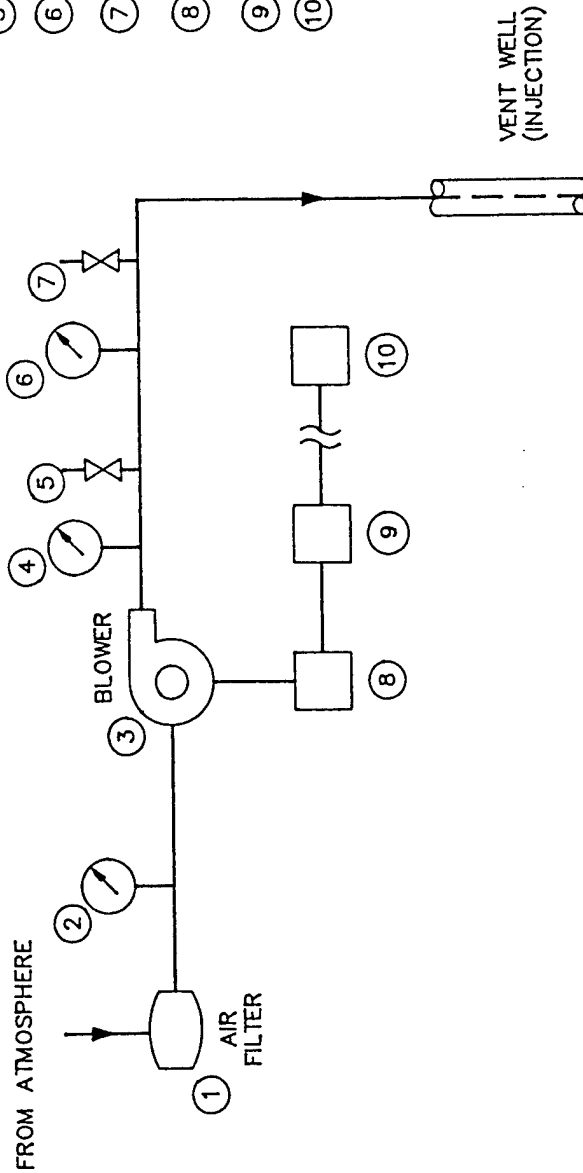

FIGURE 1.5

SITE S-4  
AS-BUILT BLOWER SYSTEM  
FOR AIR INJECTION

KELLY AFB, TEXAS

ENGINEERING-SCIENCE, INC.  
Denver, Colorado

**ES**

regarding Site S-4 can be found in the hydrogeologic cross section (Figure 1.2) and the geologic boring logs (Appendix B).

Contaminated soils were identified based on visual appearance, odor, and results of total hydrocarbon analyzer field screening for volatile organic compounds (VOCs). Heavily contaminated soils were encountered approximately 5 feet bgs in the VW and all MP boreholes. Contamination concentrations generally increased with depth (Figure 1.2).

Soil samples for laboratory analysis were collected from 18-inch split-spoon samplers with 2-inch-diameter brass liners. Soil samples were screened for VOCs using a hydrocarbon analyzer to determine the presence of contamination and to select soil samples for laboratory analysis. Soil samples for laboratory analysis were collected from MPA and MPB at a depth of 12.5 to 13 feet bgs, and from the VW at a depth of 10 feet bgs.

Soil gas samples were collected from the completed VW and at 12.5 feet bgs from MPA and MPC. Soil gas samples were collected using 3-liter Tedlar® bags and vacuum chambers. After the samples were collected with Tedlar® bags, they were transferred to 1-liter SUMMA® canisters and shipped to the laboratory.

Soil samples were shipped via Federal Express® to the ES Berkeley laboratory for chemical and physical analysis. Soil samples were analyzed for total recoverable petroleum hydrocarbons (TRPH); benzene, toluene, ethylbenzene and xylenes (BTEX); iron; alkalinity; total Kjeldahl nitrogen (TKN); and several physical parameters. Soil gas samples were shipped via Federal Express® to Air Toxics, Inc. in Rancho Cordova, California for total volatile hydrocarbon (TVH) and BTEX analysis. The TVH analyses were referenced to JP-4 jet fuel. The results of these analyses are provided in Table 1.1. Chain-of-custody forms are provided in Appendix B.

### **1.2.2 Exceptions to Test Protocol Procedures**

Procedures described in the protocol document (Hinchee et al., 1992) were used to complete the pilot test at Site S-4, with the following exception. Due to the widespread extent of fuel contamination at Site S-4, there were no suitable locations to install a background MP. Therefore, the data recovered from the background MP installed at Site FC-2 were also used as background data for Site S-4. The background MP at Site FC-2 was installed in gravelly clay soils similar to those found at Site S-4, and the background MP screens were set at approximately the same depths as the MP screens installed at Site S-4.

## **1.3 PILOT TEST RESULTS**

### **1.3.1 Initial Soil Gas Chemistry**

Prior to initiating air injection, all MPs and the VW were purged, and initial oxygen, carbon dioxide, and TVH concentrations were sampled using portable gas analyzers, as described in the technical protocol document (Hinchee et al., 1992). Table 1.2 summarizes the initial soil gas chemistry at Site S-4. The results strongly indicate that biological fuel degradation has depleted the oxygen supply in the

**TABLE 1.1**  
**SITE S-4**  
**SOIL AND SOIL GAS ANALYTICAL RESULTS**  
**KELLY AFB, TEXAS**

| <u>Analyte (Units)<sup>a/</sup></u>         | <u>Sample Location-Depth</u><br><u>(feet below ground surface)</u> |                 |                 |
|---|--|-----------------|-----------------|
|   | <u>VW-10</u>   | <u>MPA-13</u>   | <u>MPB-13</u>   |
| <u>Soil Hydrocarbons</u>                    |  |                 |                 |
| TRPH (mg/kg)                                | 1,600  | 56              | 1,100           |
| Benzene (mg/kg)                             | ND <sup>b/</sup>   | ND              | ND              |
| Toluene (mg/kg)                             | 11.0   | 5.3             | 11.0            |
| Ethylbenzene (mg/kg)                        | ND   | ND              | ND              |
| Xylenes (mg/kg)                             | 16.0   | 11.0            | 13.0            |
| <u>Soil Gas Hydrocarbons</u>                | <u>VW<sup>c/</sup></u>   | <u>MPA-12.5</u> | <u>MPC-12.5</u> |
| TVH (ppmv)                                  | 29,500   | 16,000          | 64,000          |
| Benzene (ppmv)                              | 130  | 5.0             | 420             |
| Toluene (ppmv)                              | 18.5   | 7.7             | 39              |
| Ethylbenzene (ppmv)                         | 20.5   | ND              | 45              |
| Xylenes (ppmv)                              | 17.5   | ND              | 39              |
| <u>Soil Inorganics</u>                      | <u>VW-10</u>   | <u>MPA-13</u>   | <u>MPB-13</u>   |
| Iron (mg/kg)                                | 19,900   | 19,500          | 8,730           |
| Alkalinity<br>(mg/kg as CaCO <sub>3</sub> ) | 370  | 540             | 580             |
| pH (units)                                  | 7.8  | 7.4             | 7.4             |
| TKN (mg/kg)                                 | 1,300  | 460             | 300             |
| Phosphates (mg/kg)                          | 660  | 690             | 510             |
| <u>Soil Physical Parameters</u>             | <u>VW-10</u>   | <u>MPA-13</u>   | <u>MPB-13</u>   |
| Moisture (% wt.)                            | 13.9   | 28.3            | 21.0            |
| Gravel (%)                                  | 54   | 11              | 26              |
| Sand (%)                                    | 26   | 17              | 20              |
| Silt (%)                                    | 11   | 30              | 23              |
| Clay (%)                                    | 9  | 42              | 31              |
| <u>Soil Temperature (°F)</u>                | <u>MPA-5</u>   | <u>MPA-12.5</u> |                 |
|   | 68.8   | 73.8            |                 |

a/ TRPH = total recoverable petroleum hydrocarbons; mg/kg = milligrams per kilogram; TVH = total volatile hydrocarbons; ppmv = parts per million, volume per volume; CaCO<sub>3</sub> = calcium carbonate; TKN = total Kjeldahl nitrogen, °F = degrees Fahrenheit.

b/ ND = not detected.

c/ Results averaged with duplicate sample.

**TABLE 1.2**  
**SITE S-4**  
**INITIAL SOIL GAS CHEMISTRY**  
**KELLY AFB, TEXAS**

| MP               | Depth (ft) | O <sub>2</sub> (%) | CO <sub>2</sub> (%) | Field TVH (ppmv) | Lab TVH (ppmv)   | TRPH (mg/kg) |
|------------------|------------|--------------------|---------------------|------------------|------------------|--------------|
| VW               | 7-17       | 0.0                | 11.2                | >20,000          | 30,000           | 1,600        |
| A                | 5          | 0.1                | 10.0                | >20,000          | NS <sup>a/</sup> | NS           |
| B                | 5          | 0.0                | 11.4                | 16,000           | NS               | NS           |
| C                | 5          | 1.0                | 7.8                 | >20,000          | NS               | NS           |
| A                | 9          | 0.0                | 11.2                | >20,000          | NS               | NS           |
| B                | 9          | 0.0                | 13.5                | >20,000          | NS               | NS           |
| C                | 9          | 1.2                | 11.0                | >20,000          | NS               | NS           |
| A                | 12.5       | 0.0                | 10.5                | >20,000          | 16,000           | 56           |
| B                | 12.5       | 0.0                | 12.1                | >20,000          | NS               | NS           |
| C                | 12.5       | 0.0                | 11.1                | >20,000          | 64,000           | NS           |
| BG <sup>b/</sup> | 4          | 18.6               | 0.6                 | 18               | NS               | NS           |
| BG               | 9          | 17.3               | 0.8                 | 29               | NS               | NS           |
| BG               | 13.5       | 16.3               | 2.7                 | 40               | 36               | NS           |

<sup>a/</sup>NS = not sampled

<sup>b/</sup>Background well at Site FC-2

vadose zone soils. Seven of the 10 sampling points at Site S-4 were under anaerobic conditions, and soil gas at the remaining three sampling points contained oxygen at low levels ranging from 0.1 percent to 1.2 percent. In contrast, the background MP, installed in uncontaminated soil approximately 300 feet northwest of Site FC-2, contained oxygen at levels ranging from 16.3 to 18.6 percent. Carbon dioxide was present at elevated concentrations, ranging from 7.8 to 13.5 percent, in all initial soil gas samples collected at Site S-4. The background MP carbon dioxide levels ranged from 0.6 to 2.7 percent. The high hydrocarbon concentrations in the soil gas possibly indicate the volatilization of fuel from the free product layer into the pore space of the vadose zone soils at Site S-4.

### 1.3.2 Air Permeability

An air permeability test was conducted at Site S-4 according to protocol document procedures. Air was injected into the VW for approximately 6 hours at a rate of approximately 48 acfm and an average pressure of approximately 0.8 pounds per square inch (psi). The pressure response at each MP is listed in Table 1.3. The pressure measured at all MPs achieved steady-state conditions within 5 minutes. Due to the rapid response and relatively short time to achieve steady-state conditions, the steady-state method of determining soil gas permeability was selected. As discussed in the technical protocol document (Hinchee et al., 1992), the dynamic method of determining soil gas permeability that is coded in the HyperVentilate<sup>®</sup> model is not appropriate for soils which reach steady state in less than approximately 10 minutes. Using the steady-state method, a soil gas permeability value of 20.2 darcys was calculated for this site. A radius of pressure influence of at least 30 feet was observed at all depths.

### 1.3.3 Oxygen Influence

The depth and radius of oxygen influence in the subsurface resulting from air injection into the central VW during pilot testing is the primary design parameter for full-scale bioventing systems. Optimization of full-scale and multiple VW systems requires pilot testing to determine the volume of soil that can be oxygenated at a given flow rate and VW screen configuration.

Table 1.4 describes the change in soil gas oxygen levels that occurred during a 6-hour air injection test at the site. This relatively brief air injection period at 48 acfm produced changes in soil gas oxygen levels at a distance of at least 30 feet from the central VW at all three monitored depth intervals. Significant increases in the oxygen concentration were measured at each MP interval. Based on measured pressure response, which is an indicator of long-term oxygen transport, it is anticipated that the radius of influence for a long-term bioventing system at this site will exceed 30 feet at all depths. Monitoring during the extended pilot test at this site will better define the effective treatment radius.

### 1.3.4 In Situ Respiration Rates

*In situ* respiration testing was performed at Site S-4 according to protocol document procedures. Air was injected into the VW and MP screens MPA-12.5, MPB-9, MPB-12.5, and MPC-12.5 for 16 hours at a rate of approximately 1 acfm per

TABLE 1.3  
SITE S-4  
PRESSURE RESPONSE DURING THE AIR PERMEABILITY TEST  
KELLY AFB, TEXAS

| Depth (ft)          | Pressure Response In MP (inches of water) |      |      |                  |      |      |
|---------------------|---|------|------|------------------|------|------|
|                     | MPA                                       |      | MPB  |                  | MPC  |      |
|                     | 5   | 12.5 | 5    | 12.5             | 5    | 12.5 |
| Elapsed Time (min.) |   |      |      |                  |      |      |
| 1.0                 | 5.1                                       | 6.2  | 1.2  | -- <sup>a/</sup> | --   | --   |
| 2.0                 | 6.5                                       | 6.9  | --   | 2.4              | 1.5  | --   |
| 3.0                 | --  | --   | --   | --               | --   | 1.6  |
| 4.0                 | 6.5                                       | 7.0  | 2.2  | 2.9              | --   | --   |
| 5.0                 | 6.5                                       | 7.0  | --   | --               | 2.0  | 2.1  |
| 6.0                 | 6.6                                       | 7.0  | --   | --               | --   | --   |
| 7.0                 | --  | --   | 2.45 | 3.2              | --   | 2.0  |
| 8.0                 | 6.5                                       | 6.8  | --   | --               | 2.05 | --   |
| 9.0                 | 6.5                                       | 7.0  | --   | --               | --   | --   |
| 90                  | 6.5                                       | 6.8  | 2.3  | 3.2              | 2.1  | 2.2  |
| 178                 | 6.5                                       | 6.9  | 2.35 | 3.25             | 2.15 | 2.25 |
| 235                 | 6.5                                       | 6.9  | 2.4  | 3.29             | 2.12 | 2.25 |

a/ -- denotes no reading taken at this time.

**TABLE 1.4**  
**SITE S-4**  
**INFLUENCE OF AIR INJECTION AT VENT WELL**  
**ON MONITORING POINT OXYGEN LEVELS**  
**KELLY AFB, TEXAS**

| MP | Distance<br>From VW (ft) | Depth(ft) | Initial O <sub>2</sub> (%) | Final O <sub>2</sub> (%) <sup>a/</sup> |
|----|--------------------------|-----------|----------------------------|--|
| A  | 5.3                      | 5         | 0.0                        | 20.8                                   |
| A  | 5.3                      | 9         | 0.0                        | 20.9                                   |
| A  | 5.3                      | 12.5      | 0.0                        | 20.9                                   |
| B  | 15.25                    | 5         | 0.2                        | 12.3                                   |
| B  | 15.25                    | 9         | 0.0                        | 14.8                                   |
| B  | 15.25                    | 12.5      | 0.4                        | 16.0                                   |
| C  | 30.35                    | 5         | 0.0                        | 17.8                                   |
| C  | 30.35                    | 9         | 0.6                        | 14.5                                   |
| C  | 30.35                    | 12.5      | 0.0                        | 15.0                                   |

a/ Duration of air injection=6 hours.

screened interval to deliver oxygen to contaminated soils. At the end of the 16-hour period, air injection ceased, and changes in soil gas composition were monitored over time. Oxygen, TVH, and carbon dioxide were measured over a period of 23.5 hours following the air injection period. The observed rates of oxygen utilization were then used to estimate the aerobic fuel degradation rates at Site S-4. Figures 1.6 through 1.10 present the results of *in situ* respiration testing at the site, and Table 1.5 provides a summary of the observed oxygen utilization rates.

A 3-percent mixture of helium in air was injected into the MPA-12.5 screened interval, and the loss of helium was measured for 23.5 hours following air injection. Because helium is a conservative, inert gas, the change in helium concentrations over time can be useful in determining if oxygen diffusion is responsible for a portion of the oxygen lost from each MP. Figure 1.11 compares oxygen utilization and helium retention at MPA-12.5. Helium and oxygen were lost at approximately the same rates during the early stages of the test at MPA-12.5. However, helium concentrations remained relatively constant after the initial 200 minutes of the test, while oxygen levels dropped to below 1 percent. Because the VW is only 5.3 feet from MPA-12.5 (Figure 1.1) and is screened in the same soil layer, helium was also present at the VW at the beginning of the *in situ* respiration test. Figure 1.12 illustrates the observed oxygen utilization and helium retention at the VW. Helium levels remained constant at approximately 1.4 percent throughout the test, while oxygen concentrations at the VW declined rapidly with time. Because the observed helium loss was significantly less than oxygen loss at both points, and because helium will diffuse approximately three times faster than oxygen, the measured oxygen loss can be primarily attributed to bacterial respiration rather than diffusion or faulty MP construction.

At Site S-4, an estimated 7,450 milligrams (mg) of fuel per kilogram (kg) of soil can be degraded each year. This value is the average of the fuel consumption rates calculated for every point at which a respiration test was conducted. The point-specific fuel consumption rates were calculated using observed oxygen utilization rates, estimated air-filled porosities, and a conservative ratio of 3.5 mg of oxygen consumed for every 1 mg of fuel biodegraded. Oxygen loss was rapid and linear at every sampling point during approximately the initial 400 minutes of the *in situ* respiration test. The oxygen utilization rates observed at Site S-4 ranged from 0.033 percent per minute (%/min) to 0.046 %/min (Table 1.5), demonstrating that hydrocarbon contamination is spread uniformly through the pilot test area. The air-filled porosities calculated for each sampling point ranged from 0.021 to 0.147 liter of air per kilogram of soil.

At all sampling points, the oxygen utilization rates appeared to decrease after the first 400 minutes of the test (Figures 1.6 through 1.10). This apparent decrease has been observed at other fuel spill sites where an oxygen source is in close proximity to contaminated soils. At Site S-4, an unpaved area of loose, sandy soil is located northeast of the pilot test area (Figure 1.1). The sand is apparently backfill material that was placed after the excavation and removal of the U/371 underground storage tank facility. Although the surface of the pilot test area is covered with asphalt, the unpaved area of sandy soil is a potential pathway for oxygen diffusion. As oxygen is

Figure 1.6  
 Respiration Test  
 Site S-4 : Vent Well  
 Kelly AFB, TX

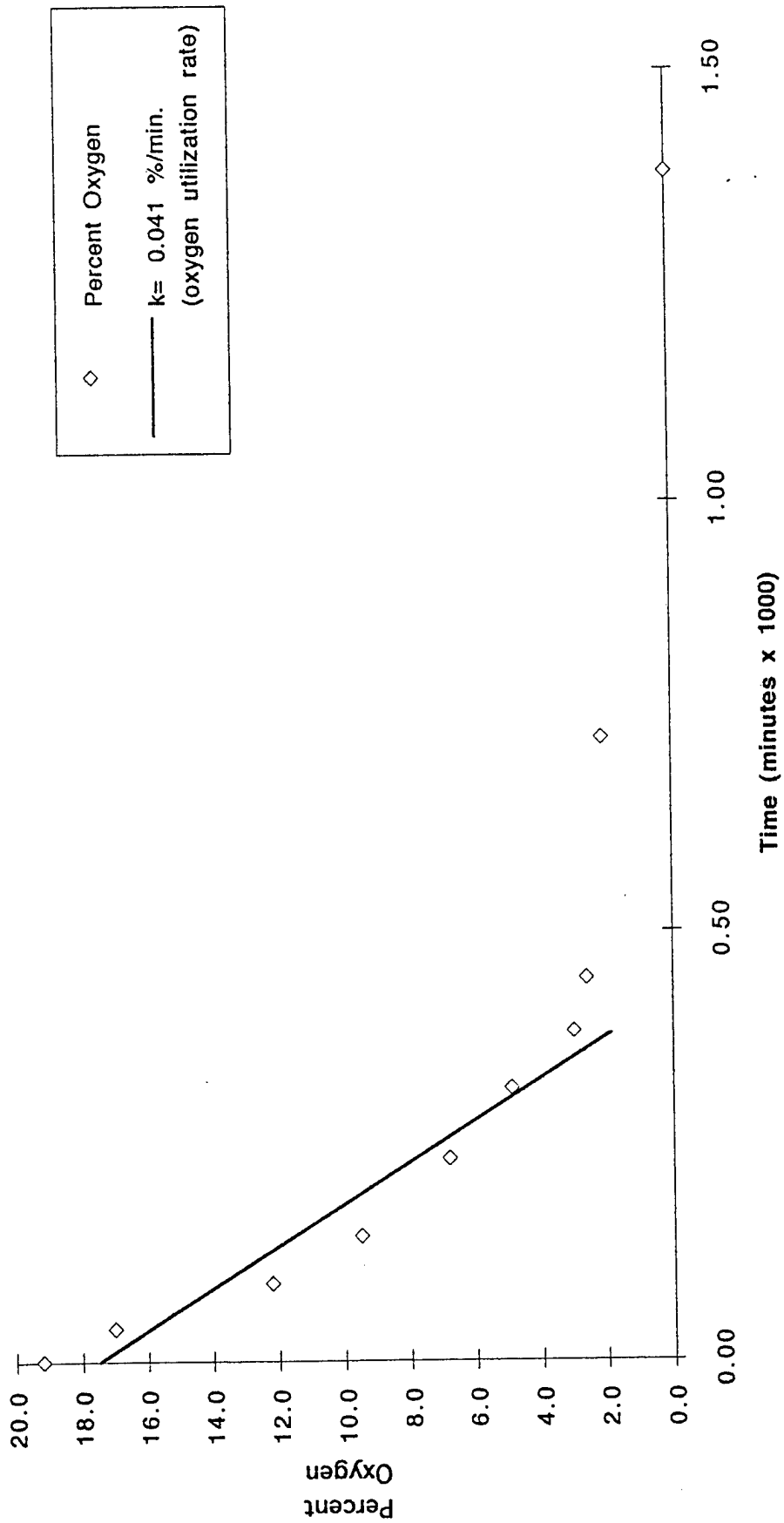

Figure 1.7  
Respiration Test  
Site S-4 : MPA-12.5  
Kelly AFB, TX

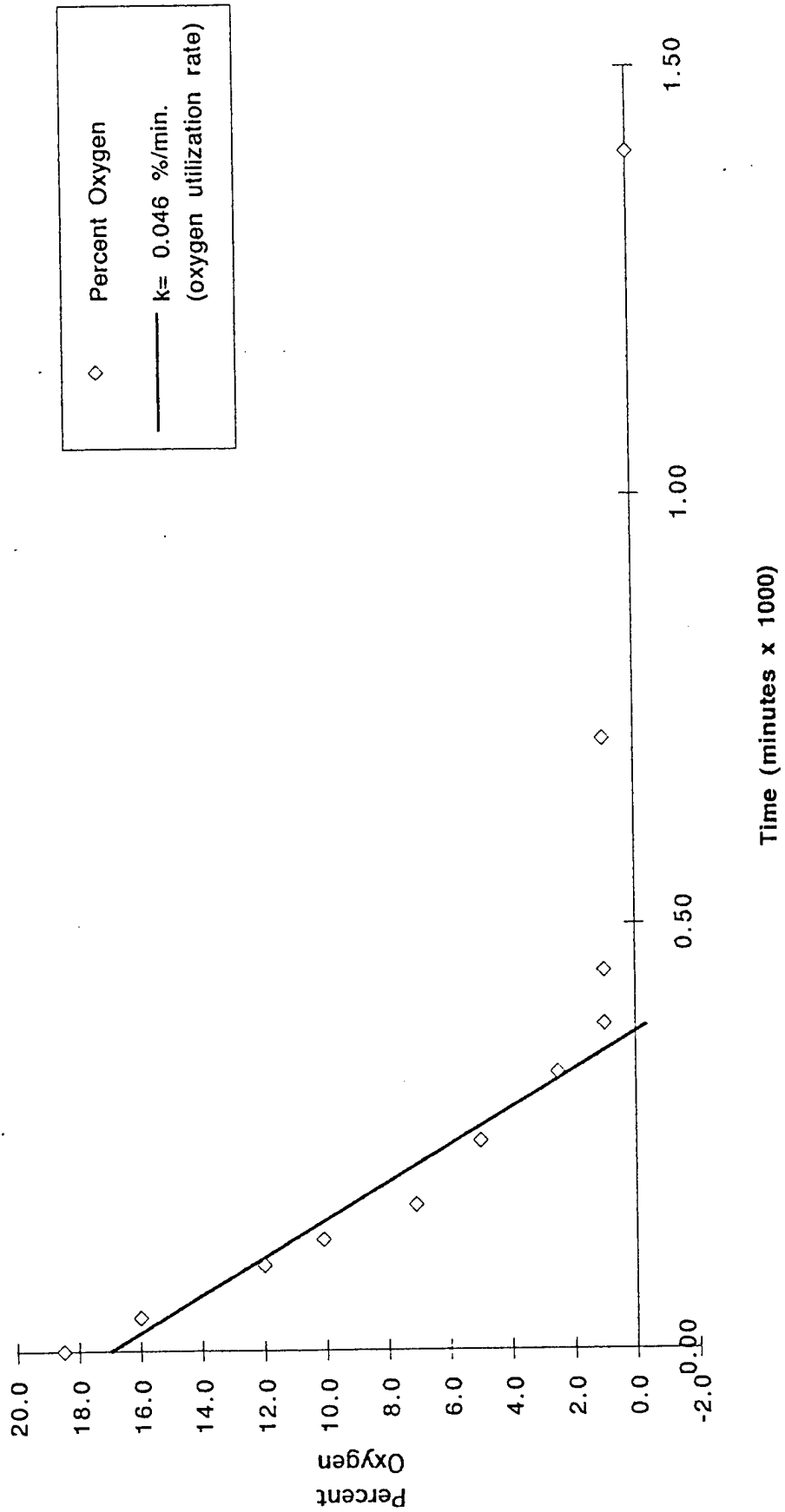

Figure 1.8  
Respiration Test  
Site S-4 : MPB-9  
Kelly AFB, TX

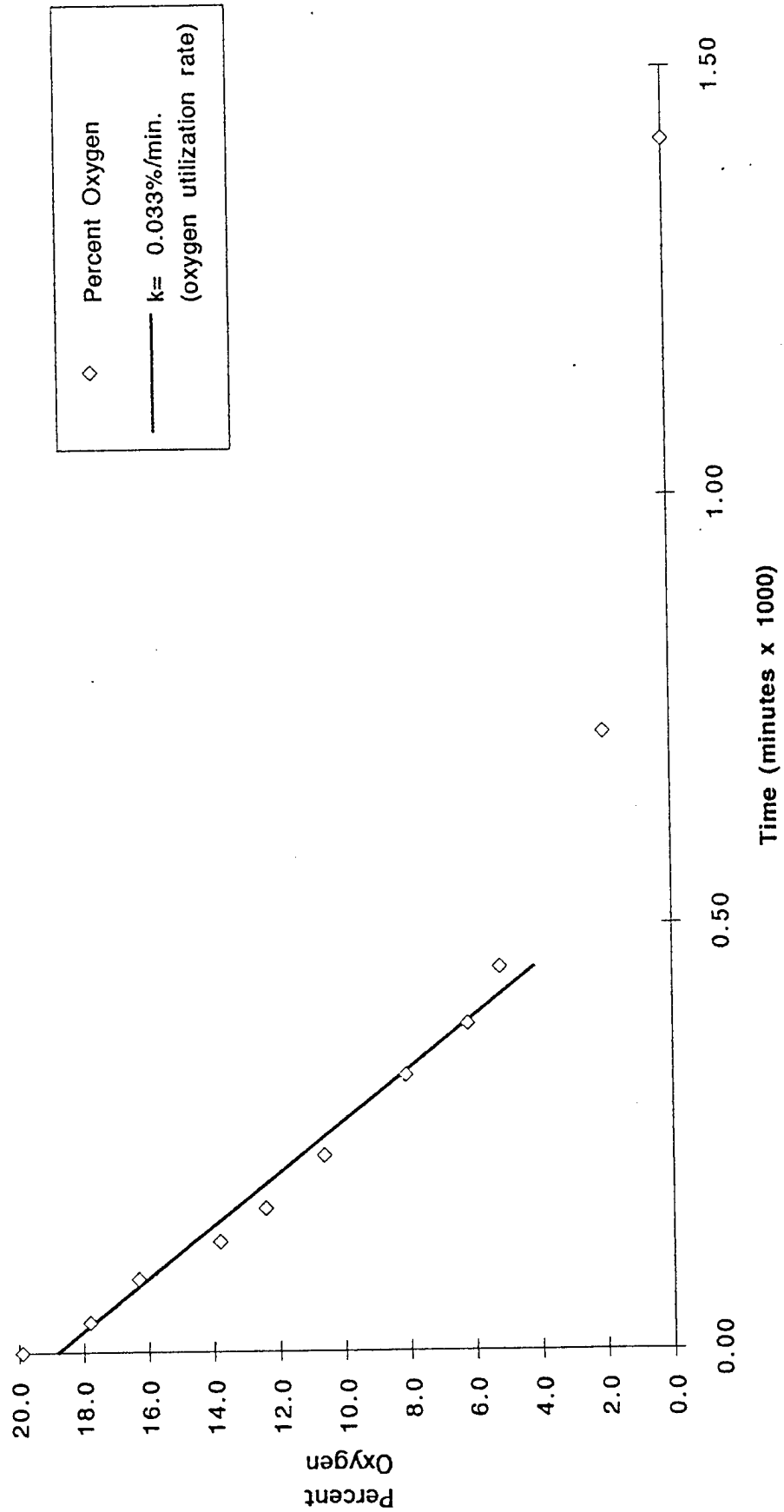

Figure 1.9  
 Respiration Test  
 Site S-4 : MPB-12.5  
 Kelly AFB, TX

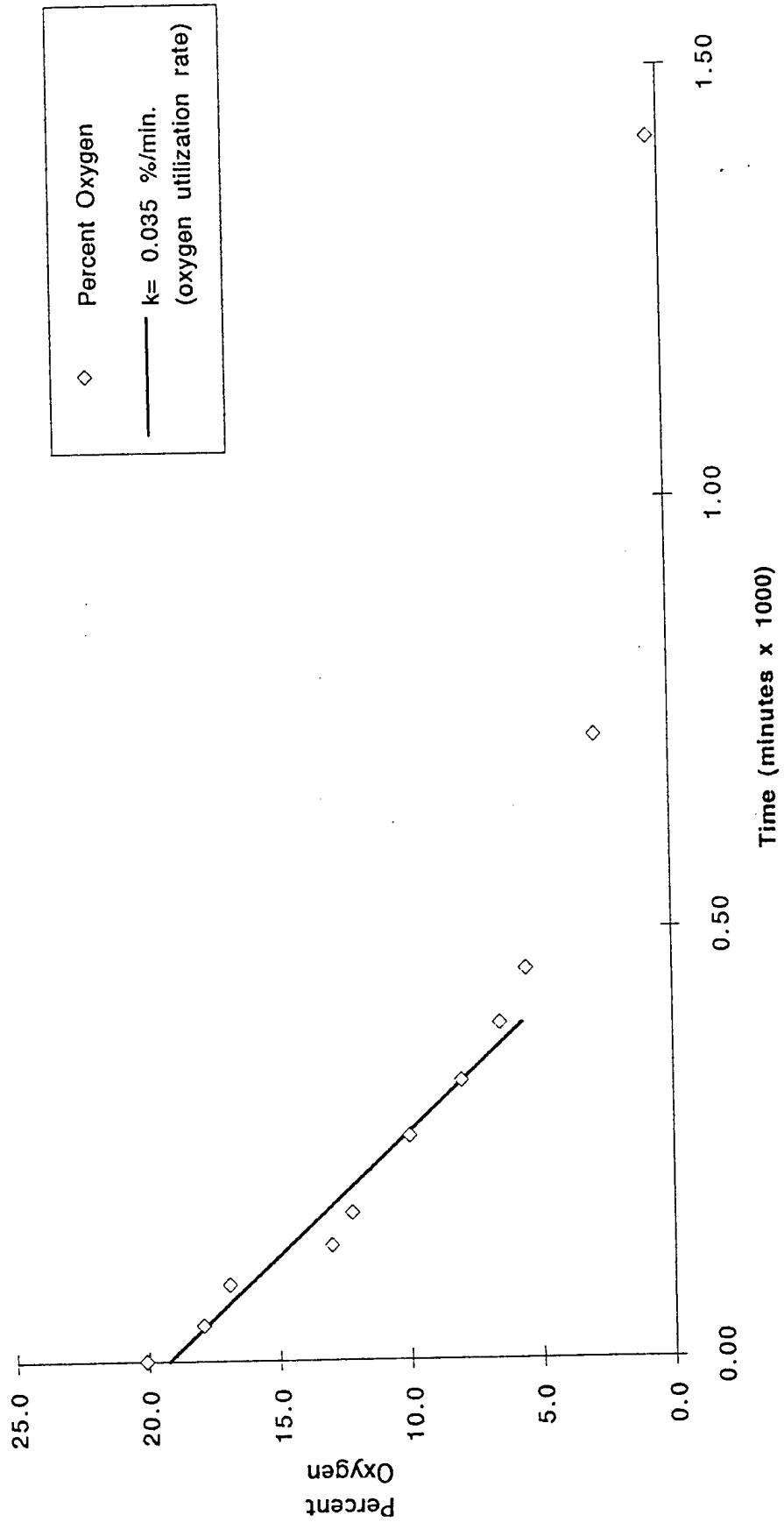

Figure 1.10  
Respiration Test  
Site S-4 : MPC-12.5  
Kelly AFB, TX

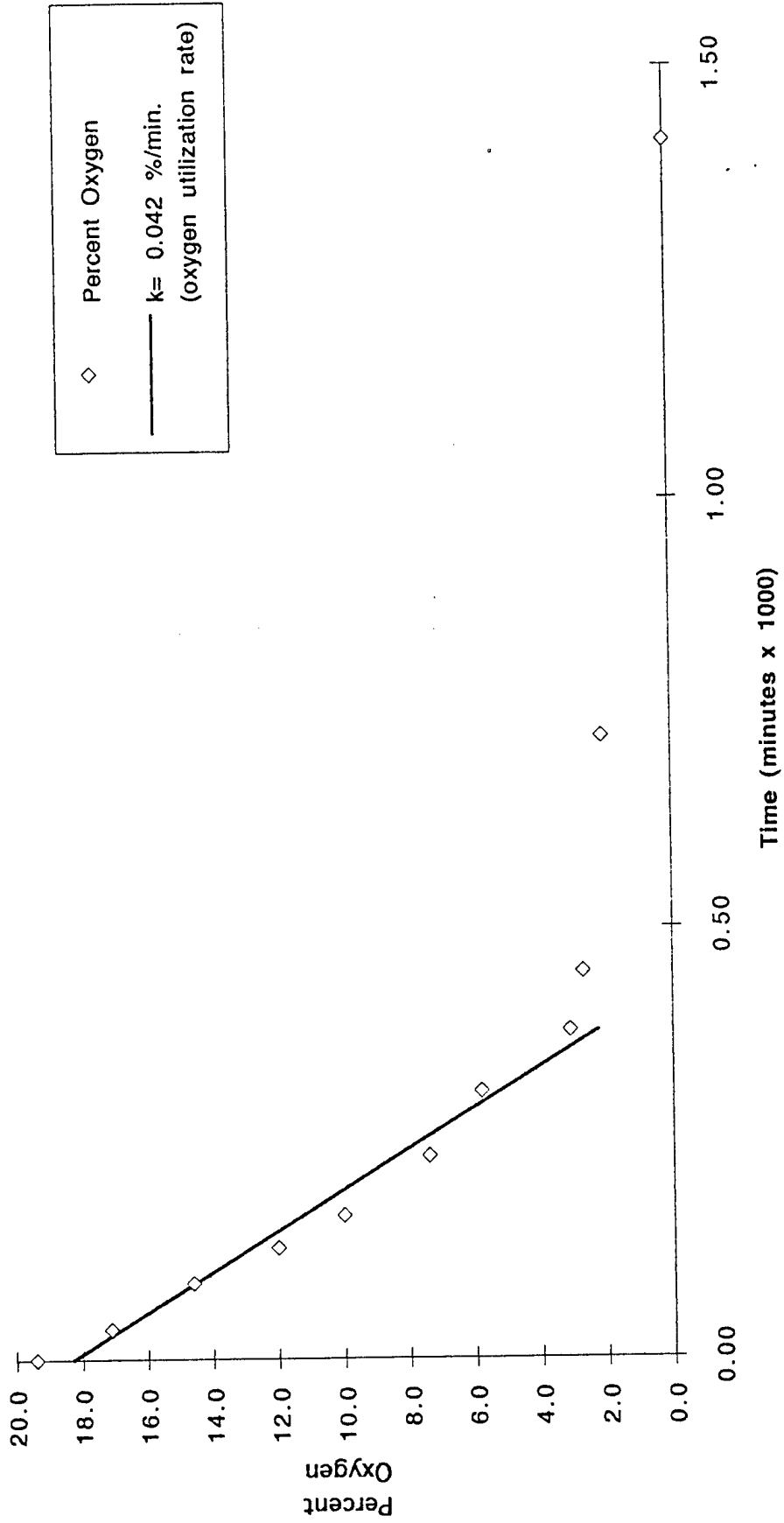

Figure 1.11  
 Respiration Test  
 Oxygen and Helium Concentrations  
 Site S-4 : MPA-12.5  
 Kelly AFB, TX

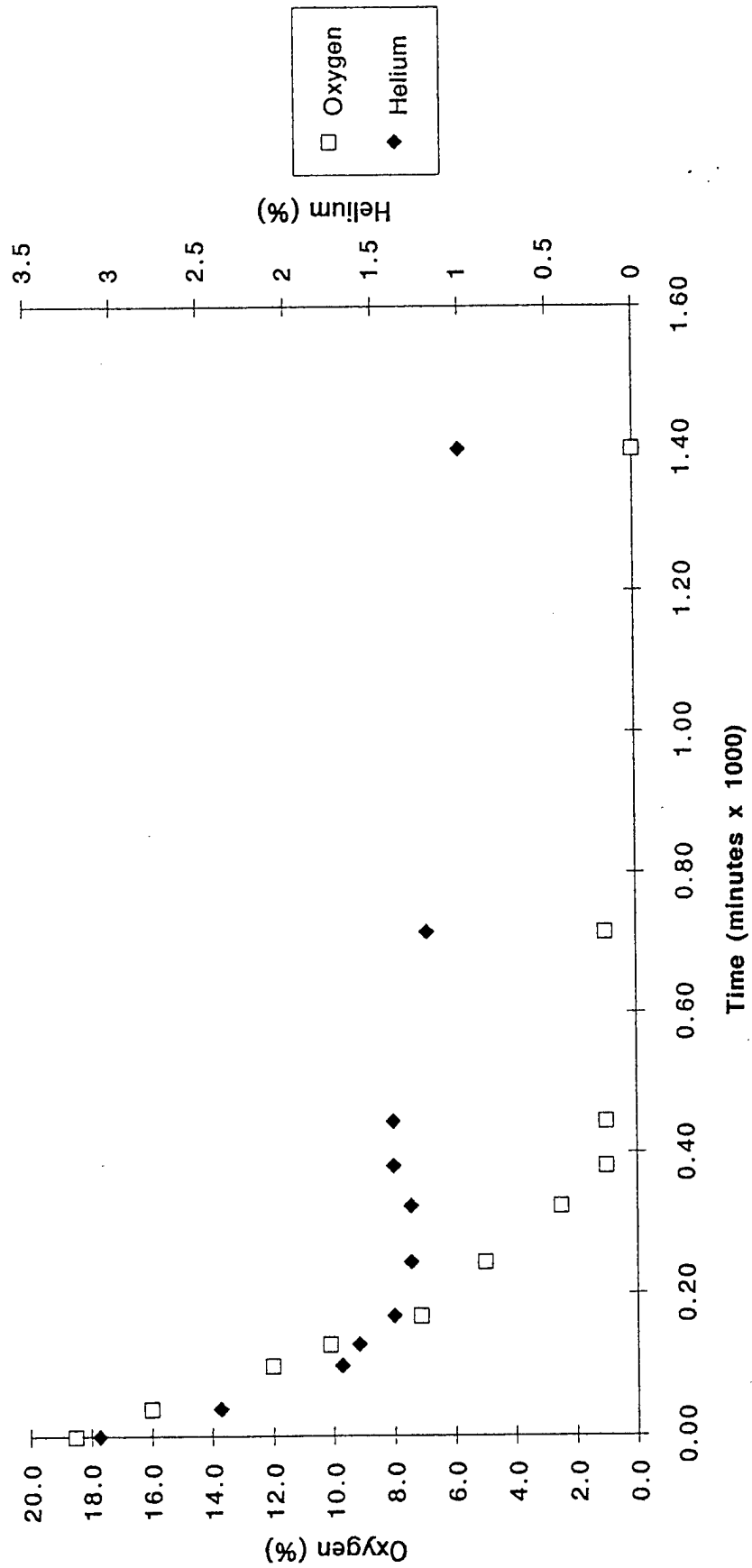
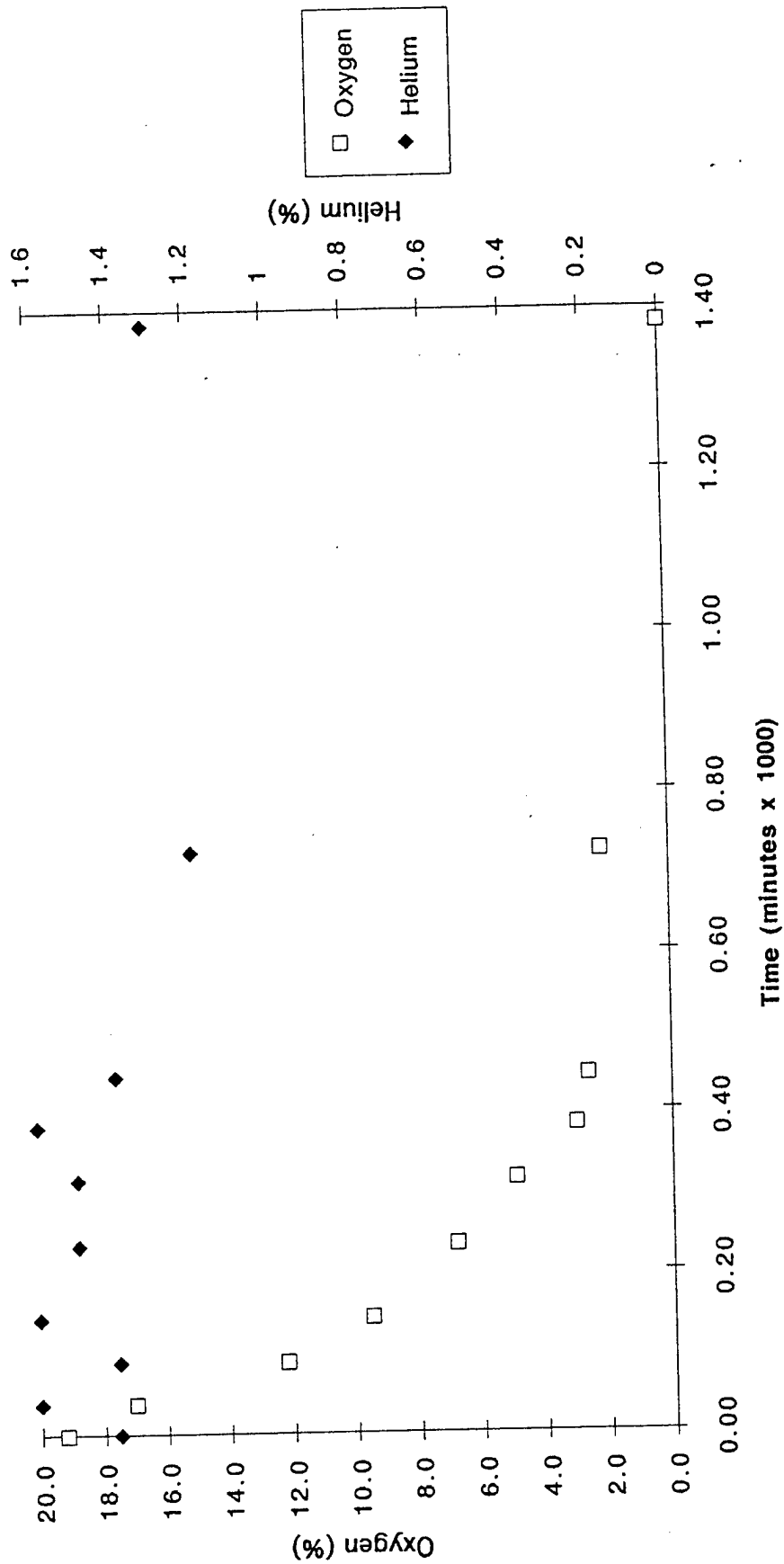

Figure 1.12  
 Respiration Test  
 Oxygen and Helium Concentrations  
 Site S-4: Vent Well  
 Kelly AFB, TX



**TABLE 1.5**  
**SITE S-4**  
**OXYGEN UTILIZATION RATES**  
**KELLY AFB, TEXAS**

| MP       | O <sub>2</sub> Loss <sup>a/</sup><br>(%) | Test<br>Duration<br>(min) | O <sub>2</sub> Utilization <sup>a/</sup><br>Rate<br>(%/min) |
|----------|--|---------------------------|---|
| VW       | 16.2                                     | 380                       | 0.041   |
| MPA-12.5 | 17.5                                     | 380                       | 0.046   |
| MPB-9    | 14.7                                     | 450                       | 0.033   |
| MPB-12.5 | 13.6                                     | 390                       | 0.035   |
| MPC-12.5 | 16.7                                     | 450                       | 0.042   |

<sup>a/</sup> Values based on linear regression (Figures 1.6 through 1.10).

rapidly consumed by fuel-degrading bacteria in contaminated soils, the oxygen diffusion gradient between the contaminated soil and the atmosphere becomes substantial. As a result, oxygen begins to diffuse from the atmosphere into the contaminated soils. This inward oxygen diffusion temporarily masks the actual bacterial oxygen uptake rates. Because fuel biodegradation generally consumes oxygen at a rate that exceeds diffusion, the oxygen concentrations soon return to zero in contaminated soils.

### 1.3.5 Potential Air Emissions

Soil concentrations of BTEX compounds detected were less than 30 mg/kg; however, the free product present at Site S-4 will continue to generate additional VOCs (Table 1.1). Thus, the long-term potential for air emissions from full-scale bioventing operations at this site is moderate. Initial emissions should be minimal because accumulated vapors will move slowly outward from the air injection point and will be biodegraded as they move horizontally through the soil. The large area of asphalt and concrete covering the site will also encourage horizontal movements and increased biodegradation. During the air permeability test, air was injected at 48 acfm. Health and safety hydrocarbon-analyzer air monitoring of the breathing zone at the site did not indicate that hydrocarbon concentrations had increased above 1 part per million, volume per volume (ppmv) during the test.

## 1.4 RECOMMENDATIONS

Initial bioventing tests at this site indicate that oxygen had been depleted in the contaminated soils, and that air injection is an effective method of stimulating aerobic fuel biodegradation. AFCEE has recommended that air injection continue at this site to determine the long-term radius of oxygen influence and the effect of time, available nutrients, and changing temperatures on fuel biodegradation rates.

A 1-horsepower regenerative blower has been installed at the site for continuous air injection. In June 1993, ES will return to the site to sample and analyze the soil gas and conduct a repeat respiration test. In December 1993, a final respiration test will be conducted, and soil and soil gas samples will be collected from the site to determine the degree of remediation achieved during the first year of *in situ* treatment. It is important to note that without some form of free product removal, soils will be subject to recontamination as groundwater levels rise.

Based on the results of the first year of pilot-scale bioventing, AFCEE will recommend one of three options:

1. Upgrade the pilot-scale system, if necessary, and continue operation of the bioventing system for full-scale remediation of the site. Evaluate the need for integrating bioventing with free product recovery. AFCEE can assist the base in obtaining regulatory approval for upgrading and continued operation.
2. If final soil sampling indicates significant contaminant removal has occurred, AFCEE may recommend additional sampling to confirm that cleanup criteria have been achieved.

3. If significant difficulties or poor results are encountered during bioventing at this site, AFCEE may recommend removal of the blower system and proper abandonment of the VW and MPs.

## **2.0 SITE FC-2**

### **2.1 Pilot Test Design and Construction**

Installation of an air injection VW and three MPs at Site FC-2 began on 9 December 1992, and was completed on 10 December 1992. Drilling services were provided by Jones Environmental Drilling, Inc., of Corpus Christi, Texas. Well installation and soil sampling were directed by Mr. John Ratz, the ES site manager, and Mr. John Pawlik, the ES site geologist. The following sections describe the final design and installation of the bioventing system at this site.

One VW, three MPs (MPA, MPB, and MPC), and a blower unit were installed at Site FC-2. Figures 2.1 and 2.2, respectively, depict the locations of and hydrogeologic cross sections for the VW and MPs completed at Site FC-2. A background MP for this site (BG) was placed approximately 10 feet west of existing groundwater monitoring well TC-03, located approximately 300 feet northwest of the VW. The location of the BG is shown on Figure 2.1.

#### **2.1.1 Air Injection Vent Well**

The air injection VW was installed following procedures described in the AFCEE bioventing protocol document (Hinchee et al., 1992). The VW was installed in gravelly clay that contained hydrocarbon contamination below 12 feet bgs. Groundwater was encountered at a depth of 15 feet bgs. Figure 2.3 shows construction details for the VW. The VW was constructed using 4-inch-diameter, Schedule 40 PVC casing, with 12 feet of 0.04-inch slotted PVC screen installed from 7 to 19 feet bgs. The annular space between the well casing and borehole was filled with 6-9 silica sand from the bottom of the borehole to approximately 1.5 feet above the well screen. Approximately 4 feet of granular bentonite was placed above the sand in 6-inch lifts, with each lift being hydrated in place. On top of the bentonite layer, approximately 1.5 feet of concrete was placed and was finished flush with the ground surface. The well casing was cut off approximately 2 feet above the surface, and the casing was connected to a galvanized steel header using a rubber pipe coupler.

#### **2.1.2 Monitoring Points**

The MP screens were installed at 4-, 9-, and 13.5-foot depths. The three MPs (MPA, MPB, and MPC) at Site FC-2 were constructed as shown in Figures 2.2 and 2.4. Each MP interval was constructed using a 6-inch section of 1-inch-diameter PVC well screen and a 0.25-inch-diameter PVC riser pipe extending to the ground surface. At the top of each riser, a ball valve and a 3/16-inch hose barb were installed. The top of each MP was completed with a flush-mounted metal well protector set in a concrete base. Thermocouples were installed at the 4- and 13.5-foot depths at MPA to measure soil temperature variations. The background MP

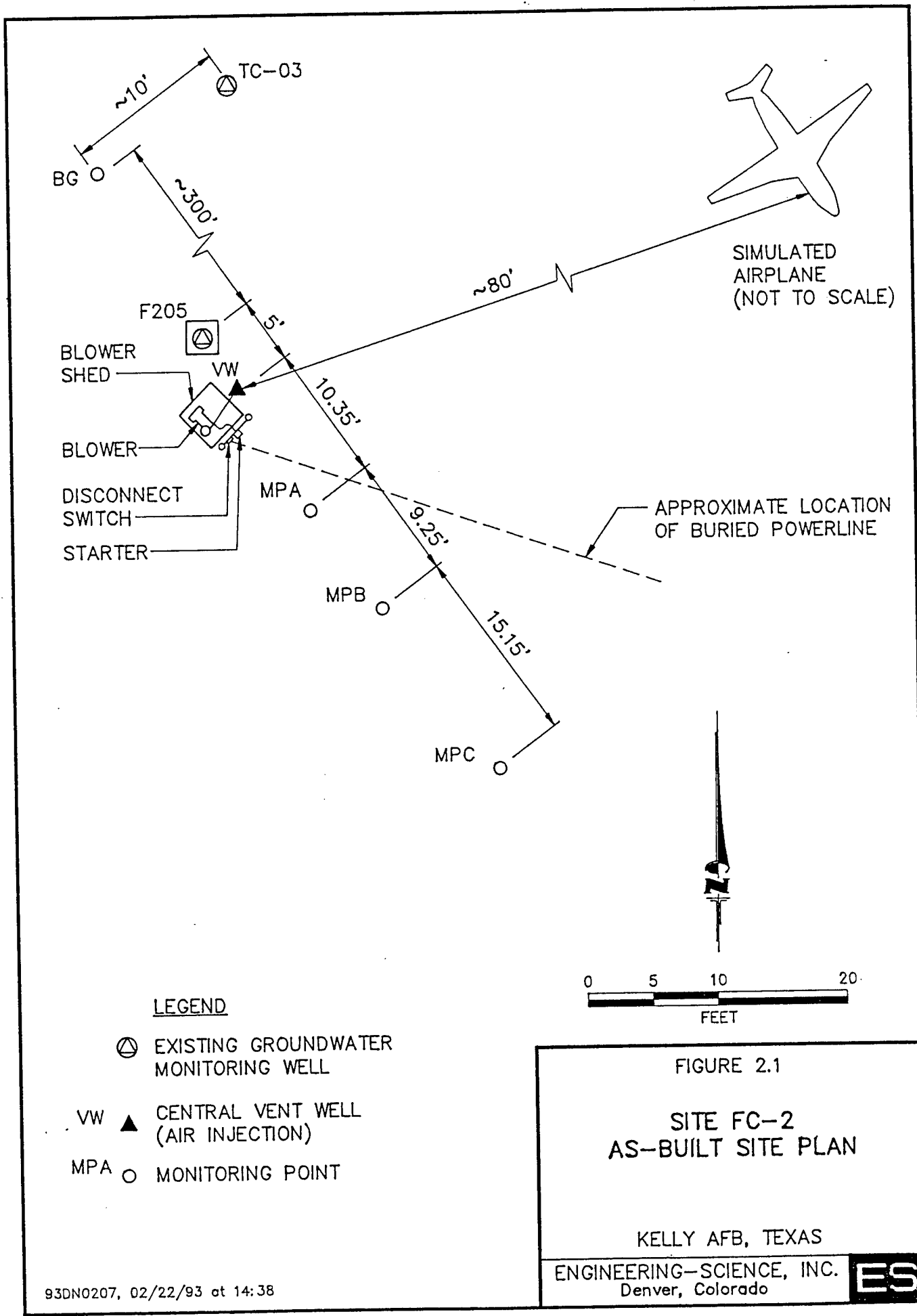

**LEGEND**

- ⊙ EXISTING GROUNDWATER MONITORING WELL
- VW ▲ CENTRAL VENT WELL (AIR INJECTION)
- MPA ○ MONITORING POINT

FIGURE 2.1  
**SITE FC-2  
 AS-BUILT SITE PLAN**  
 KELLY AFB, TEXAS  
 ENGINEERING-SCIENCE, INC.  
 Denver, Colorado **ES**

93DN0207, 02/22/93 at 14:38

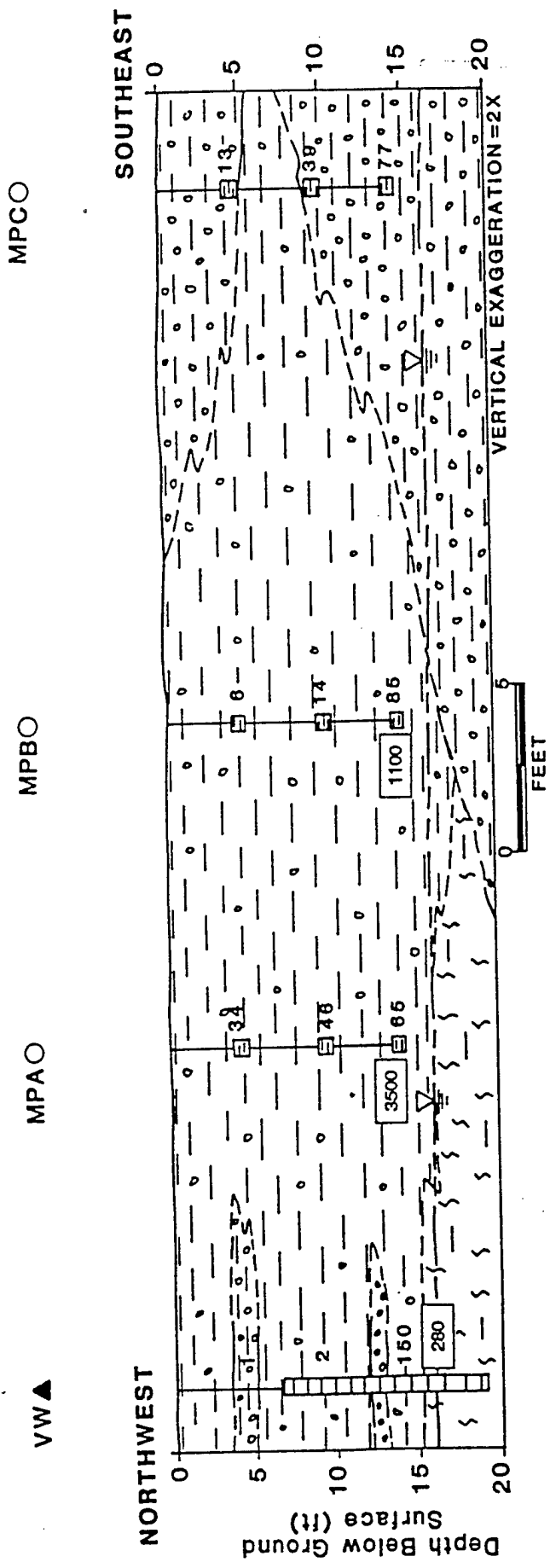

**LITHOLOGIC DESCRIPTION**

- GRAVELLY CLAY
- CLAY & GRAVEL
- GRAVEL
- SILT

**LEGEND**

- MPA ○ MONITORING POINT
- VW ▲ INJECTION VENT WELL
- 150 FIELD SCREENING RESULTS FOR TOTAL VOLATILE HYDROCARBONS (ppmv)
- 280 LABORATORY RESULTS FOR SOIL TOTAL PETROLEUM HYDROCARBONS (mg/kg)
- GROUNDWATER ELEVATION
- GEOLOGIC CONTACT, DASHED WHERE INFERRED
- MONITORING POINT SCREENED INTERVAL
- SCREENED WELL INTERVAL

FIGURE 2.2

**SITE FC-2  
HYDROGEOLOGIC  
CROSS SECTION**

KELLY AFB, TEXAS

ENGINEERING-SCIENCE, INC.  
Denver, Colorado

**ES**

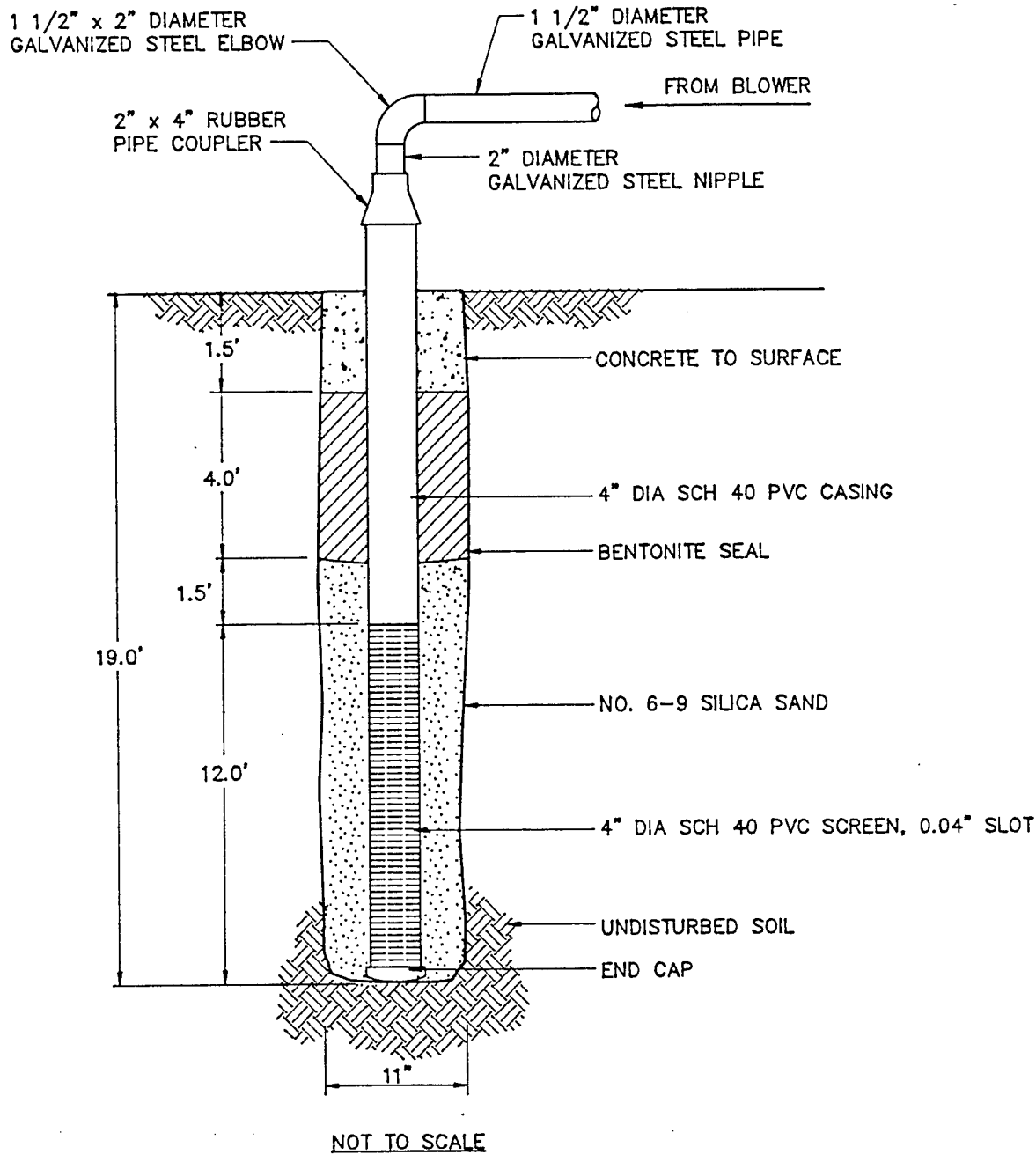

FIGURE 2.3  
 SITE FC-2  
 AS-BUILT INJECTION VENT WELL  
 CONSTRUCTION DETAIL

KELLY AFB, TEXAS

ENGINEERING-SCIENCE, INC.  
 Denver, Colorado



located near existing groundwater monitoring well TC-03 was also constructed as shown in Figure 2.4.

### **2.1.3 Blower Unit**

During the initial pilot test, a portable 3-horsepower Roots® 22U-RAI positive-displacement blower unit was used. A 2.5-horsepower Gast® R5125Q-50 regenerative blower unit was installed at Site FC-2 and connected to the air injection VW for the extended pilot test. The fixed unit is energized by 240-volt, single-phase, 30-amp line power from a newly installed underground power line and aboveground breaker provided by the base. The configuration and instrumentation for this system are shown on Figure 2.5. The blower is currently transporting air at a flow rate of approximately 114 acfm for the extended pilot test. A portion of this flow is being bled off through the gate valve. After blower installation and startup, ES engineers provided an O&M manual, including maintenance instructions, equipment specifications and monitoring forms, to base personnel. A copy of the O&M instructions is provided in Appendix A.

## **2.2 PILOT TEST SOIL AND SOIL GAS SAMPLING RESULTS**

### **2.2.1 Sampling Results**

Soils at this site primarily consist of gravelly clay with some gravel and silt. Groundwater was encountered at a depth of approximately 15.0 feet bgs in the VW. No free product was encountered at the VW or existing monitoring well F205 (Figure 2.1). More detailed hydrogeologic information regarding Site FC-2 can be found in the hydrogeologic cross section (Figure 2.2) and the geologic boring logs (Appendix B).

Contaminated soils were identified based on visual appearance, odor, and VOC field screening results. Heavily contaminated soils were encountered between 10 and 15 feet bgs in the VW and each MP borehole. Soils at these locations had a strong hydrocarbon odor.

Soil samples for laboratory analysis were collected from 18-inch split-spoon samplers with 2-inch-diameter brass liners. Soil samples were screened for VOCs using a photoionization detector (PID) to determine the presence of contamination and to select soil samples for laboratory analysis. Soil samples for laboratory analysis were collected from MPA at a depth of 14 feet bgs, from MPB at a depth of 14 feet bgs, and from the VW at a depth of 15 feet bgs.

Soil gas samples were collected from the completed VW, and at 13.5 feet bgs from MPA, MPC, and the background MP. Soil gas samples were collected using 3-liter Tedlar® bags and vacuum chambers. After the samples were collected in the Tedlar® bags, they were transferred into 1-liter SUMMA® canisters and shipped to the laboratory.

Soil samples were shipped via Federal Express® to the ES Berkeley laboratory for chemical and physical analysis. Soil samples were analyzed for TRPH, BTEX, iron, alkalinity, TKN, and several physical parameters. Soil gas samples were shipped via Federal Express® to Air Toxics, Inc. in Rancho Cordova, California for

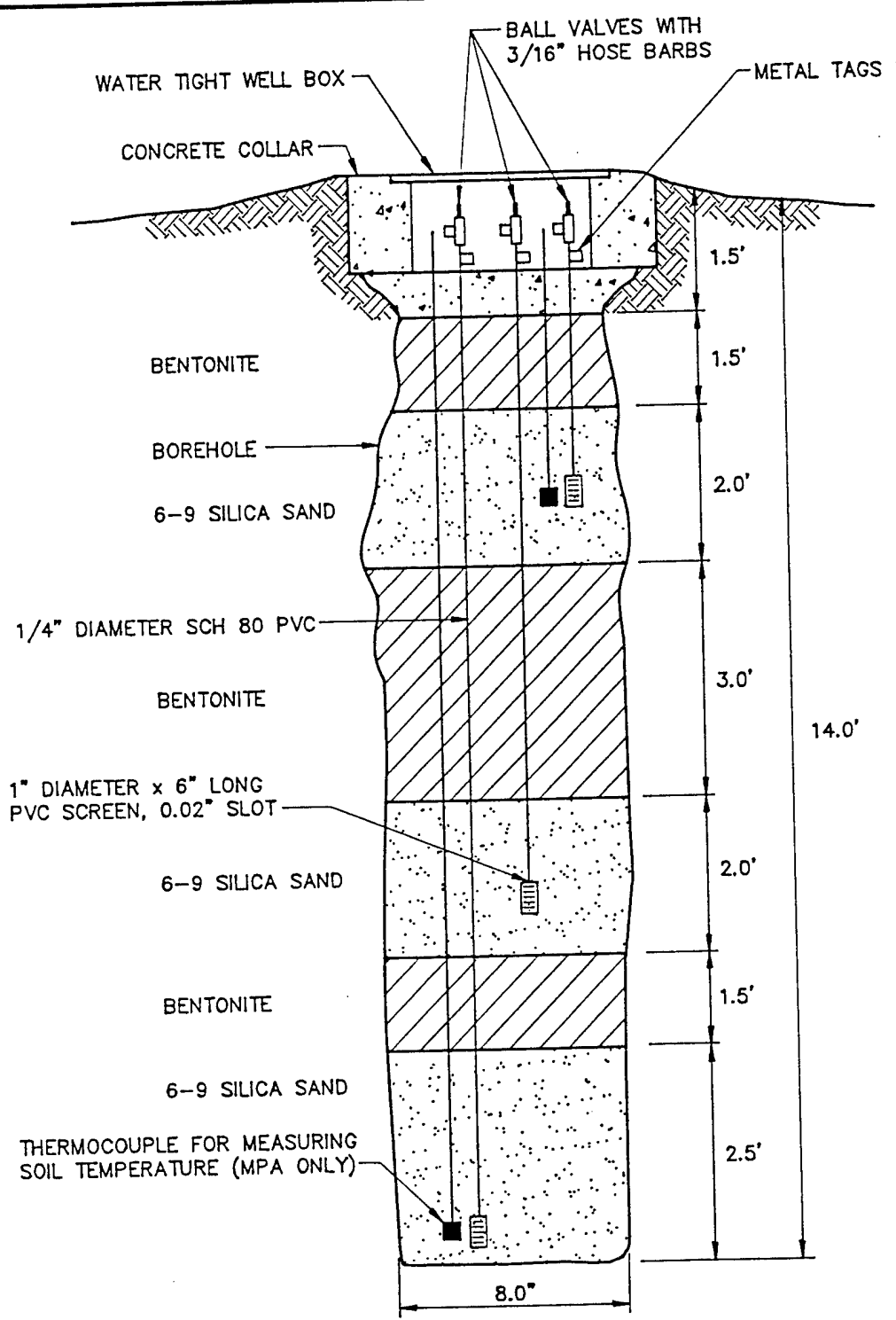

FIGURE 2.4  
 SITE FC-2  
 AS-BUILT MONITORING POINT  
 CONSTRUCTION DETAIL  
 KELLY AFB, TEXAS  
 ENGINEERING-SCIENCE, INC.  
 Denver, Colorado



LEGEND

- ① INLET AIR FILTER - SOLBERG® AJ134E
- ② VACUUM GAUGE (0-60 in H<sub>2</sub>O)
- ③ BLOWER - GAST® 2HP R5125Q-50
- ④ TEMPERATURE GAUGE (0-250 °F)
- ⑤ AUTOMATIC PRESSURE RELIEF VALVE, SET TO RELEASE AT 60 IN H<sub>2</sub>O PRESSURE
- ⑥ PRESSURE GAUGE (0-100 in H<sub>2</sub>O)
- ⑦ MANUAL PRESSURE RELIEF (BLEED) VALVE - 1 1/2" GATE
- ⑧ STARTER - FURNAS® 14CSE32DA NEMA 3, WITH START/STOP, OVERLOAD SET AT 13AMPS
- ⑨ DISCONNECT SWITCH - 240V/SINGLE PHASE/30 AMP, FUSED DISCONNECT (GENERAL DUTY)
- ⑩ POWER POLE DISCONNECT SWITCH - 600V/30 AMP

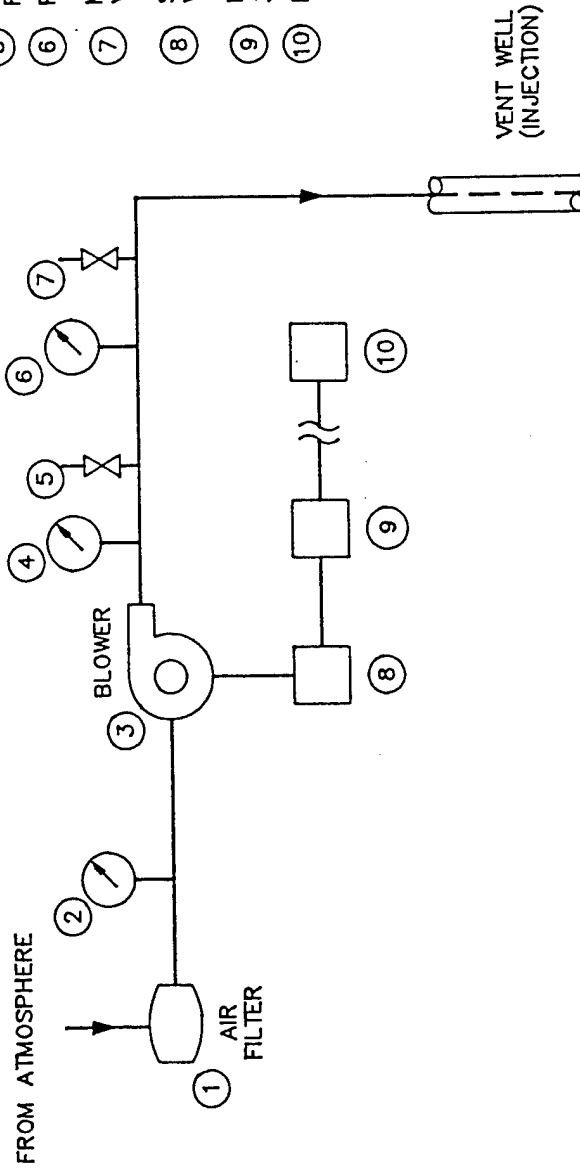

FIGURE 2.5

SITE FC-2  
AS-BUILT BLOWER SYSTEM  
FOR AIR INJECTION

KELLY AFB, TEXAS

ENGINEERING-SCIENCE, INC.  
Denver, Colorado

**ES**

TVH and BTEX analysis. TVH analyses were referenced to JP-4 jet fuel. The results of these analyses are provided in Table 2.1. Chain-of-custody forms are provided in Appendix B.

### **2.2.2 Exceptions To Test Protocol Procedures**

Procedures described in the protocol document (Hinchee et al., 1992) were used to complete treatability tests Site FC-2, with the following exception. A HNu® PID rather than a hydrocarbon analyzer was used to field screen the soil samples and monitor the breathing zone while drilling the borehole for the VW only. The hydrocarbon analyzer was used during drilling activity at the MPs, per the protocol document.

## **2.3 PILOT TEST RESULTS**

### **2.3.1 Initial Soil Gas Chemistry**

Prior to initiating any air injection, all MPs and the VW were purged, and initial oxygen, carbon dioxide, and TVH concentrations were sampled using portable gas analyzers, as described in the technical protocol document (Hinchee et al., 1992). Table 2.2 summarizes the initial soil gas chemistry at Site FC-2. The results strongly indicate that biological fuel degradation has depleted oxygen supplies in deep vadose zone soils at Site FC-2. Oxygen was depleted in highly contaminated areas, including the VW and the MP screened intervals 9 and 13.5 feet bgs. Points with little or no fuel contamination, such as the screens 4 feet bgs at MPA and MPB and at all depths of the background MP (installed in clean soils approximately 300 feet northwest of the contaminated pilot test area), contained oxygen ranging from 2.7 to 18.6 percent. In the pilot test area, carbon dioxide was present at elevated concentrations ranging from 2.7 to 10.9 percent. In contrast, the carbon dioxide levels at the background MP ranged from 0.6 to 2.7 percent.

### **2.3.2 Air Permeability**

An air permeability test was conducted at Site FC-2 according to protocol document procedures. Air was injected into the VW for approximately 23 hours at a rate of approximately 48 acfm and an average pressure of approximately 0.9 psi. The pressure response at each MP is listed in Table 2.3. The pressure measured at all MPs achieved steady-state conditions within 5 to 10 minutes, but the test was continued for a 23-hour period to assure steady-state conditions over an extended period of time and to demonstrate oxygen influence. Due to the rapid response and relatively short time to achieve steady-state conditions, the steady-state method of determining soil gas permeability was selected. As discussed in the technical protocol document (Hinchee et al., 1992), the dynamic method of determining soil gas permeability that is coded in the HyperVentilate® model is not appropriate for soils which reach steady state in less than about 10 minutes. Using the steady-state method, a soil gas permeability value of 14.7 darcys was calculated for this site. A radius of pressure influence of at least 35 feet was observed at the 4-, 9-, and 13.5-foot depths.

**TABLE 2.1**  
**SITE FC-2**  
**SOIL AND SOIL GAS ANALYTICAL RESULTS**  
**KELLY AFB, TEXAS**

| <u>Analyte (Units)<sup>a/</sup></u>         | <u>Sample Location-Depth</u><br><u>(feet below ground surface)</u> |                 |                 |
|---|--|-----------------|-----------------|
|   | <u>VW-15</u>   | <u>MPA-14</u>   | <u>MPB-14</u>   |
| <u>Soil Hydrocarbons</u>                    |  |                 |                 |
| TRPH (mg/kg)                                | 280  | 3,500           | 1,100           |
| Benzene (mg/kg)                             | ND <sup>b/</sup>   | ND              | ND              |
| Toluene (mg/kg)                             | 9.1  | 12.0            | 2.9             |
| Ethylbenzene (mg/kg)                        | ND   | ND              | ND              |
| Xylenes (mg/kg)                             | 11.0   | 40.0            | 15.0            |
| <u>Soil Gas Hydrocarbons</u>                | <u>VW</u>  | <u>MPA-13.5</u> | <u>MPC-13.5</u> |
| TVH (ppmv)                                  | 4,200  | 16,000          | 17,000          |
| Benzene (ppmv)                              | 14   | 58              | 43              |
| Toluene (ppmv)                              | 7.4  | 20              | 18              |
| Ethylbenzene (ppmv)                         | 7.0  | 24              | 24              |
| Xylenes (ppmv)                              | 5.4  | 19              | 22              |
| <u>Soil Inorganics</u>                      | <u>VW-15</u>   | <u>MPA-14</u>   | <u>MPB-14</u>   |
| Iron (mg/kg)                                | 18,300   | 10,600          | 11,200          |
| Alkalinity<br>(mg/kg as CaCO <sub>3</sub> ) | 350  | 410             | 1,500           |
| pH (units)                                  | 8.0  | 7.8             | 8.9             |
| TKN (mg/kg)                                 | 430  | 580             | 750             |
| Phosphates (mg/kg)                          | 1,200  | 510             | 650             |
| <u>Soil Physical Parameters</u>             | <u>VW-15</u>   | <u>MPA-14</u>   | <u>MPB-14</u>   |
| Moisture (% wt.)                            | 20.0   | 19.4            | 20.8            |
| Gravel (%)                                  | 30   | 21              | 8               |
| Sand (%)                                    | 26   | 27              | 15              |
| Silt (%)                                    | 22   | 29              | 28              |
| Clay (%)                                    | 22   | 23              | 49              |
| <u>Soil Temperature (°F)</u>                | <u>MPA-4</u>   | <u>MPA-13.5</u> |                 |
|   | 64.4   | 76.8            |                 |

a/ TRPH = total recoverable petroleum hydrocarbons; mg/kg = milligrams per kilogram; TVH = total volatile hydrocarbons; ppmv = parts per million, volume per volume; CaCO<sub>3</sub> = calcium carbonate; TKN = total Kjeldahl nitrogen, °F = degrees Fahrenheit.  
b/ ND = not detected.

**TABLE 2.2**  
**SITE FC-2**  
**INITIAL SOIL GAS CHEMISTRY**  
**KELLY AFB, TEXAS**

| MP               | Depth (ft) | O <sub>2</sub> (%) | CO <sub>2</sub> (%) | Field TVH (ppmv) | Lab TVH (ppmv)   | TRPH (mg/kg) |
|------------------|------------|--------------------|---------------------|------------------|------------------|--------------|
| VW               | 7-19       | 0.0                | 10.9                | 1,300            | 4,200            | 280          |
| A                | 4          | 2.7                | 7.2                 | 28               | NS <sup>a/</sup> | NS           |
| A                | 9          | 0.0                | 8.7                 | 620              | NS               | NS           |
| A                | 13.5       | 0.3                | 8.4                 | 1,500            | 16,000           | 3,500        |
| B                | 4          | 12.8               | 2.7                 | 24               | NS               | NS           |
| B                | 9          | 0.0                | 6.4                 | 310              | NS               | NS           |
| B                | 13.5       | 0.0                | 5.4                 | 760              | NS               | 1,100        |
| C                | 4          | 6.8                | 4.0                 | 1,300            | NS               | NS           |
| C                | 9          | 0.3                | 8.2                 | 1,700            | NS               | NS           |
| C                | 13.5       | 0.4                | 8.2                 | 3,800            | 17,000           | NS           |
| BG <sup>b/</sup> | 4          | 18.6               | 0.6                 | 18               | NS               | NS           |
| BG               | 9          | 17.3               | 0.8                 | 29               | NS               | NS           |
| BG               | 13.5       | 16.3               | 2.7                 | 40               | 36               | NS           |

a/NS = not sampled  
b/BG = background

**TABLE 2.3**  
**SITE FC-2**  
**PRESSURE RESPONSE DURING THE AIR PERMEABILITY TEST**  
**KELLY AFB, TEXAS**

| Depth (ft)          | Pressure Response In MP (inches of water) |      |      |      |      |                  |      |
|---------------------|---|------|------|------|------|------------------|------|
|                     | MPA                                       |      | MPB  |      | MPC  |                  |      |
|                     | 4   | 13.5 | 4    | 9    | 4    | 9                |      |
| Elapsed Time (min.) |   |      |      |      |      |                  |      |
| 1.0                 | 0.45                                      | 0.6  | 0.3  | 0.1  | 0.15 | -- <sup>a/</sup> | --   |
| 2.0                 | --  | 1.0  | --   | --   | --   | 0.1              | 0.05 |
| 3.0                 | 1.05                                      | 1.0  | 0.4  | --   | 0.30 | --               | --   |
| 4.0                 | 1.05                                      | 0.95 | --   | 0.35 | --   | 0.15             | 0.05 |
| 5.0                 | 1.05                                      | 0.89 | --   | --   | 0.35 | --               | --   |
| 6.0                 | 1.02                                      | --   | --   | 0.35 | 0.35 | --               | --   |
| 7.0                 | 1.04                                      | 1.0  | 0.4  | --   | --   | --               | --   |
| 8.0                 | --  | 1.0  | --   | 0.35 | 0.35 | --               | --   |
| 9.0                 | 1.02                                      | --   | 0.4  | 0.35 | 0.35 | --               | --   |
| 10.0                | --  | --   | --   | --   | --   | 0.2              | 0.15 |
| 15                  | 1.0                                       | 0.95 | 0.4  | 0.35 | 0.35 | --               | --   |
| 95                  | 1.04                                      | 0.95 | 0.4  | 0.45 | 0.4  | 0.23             | 0.15 |
| 135                 | 1.15                                      | 1.1  | --   | --   | --   | 0.29             | 0.18 |
| 165                 | 1.20                                      | 1.15 | 0.48 | 0.42 | 0.45 | 0.22             | 0.15 |
| 410                 | 1.27                                      | 1.23 | 0.44 | 0.38 | 0.33 | 0.24             | 0.18 |
| 1,400               | 1.11                                      | 1.08 | 0.40 | 0.32 | 0.30 | 0.20             | 0.18 |

a/ -- denotes no reading taken at this time.

### 2.3.3 Oxygen Influence

The depth and radius of oxygen influence in the subsurface resulting from air injection into the central VW during pilot testing is the primary design parameter for full-scale bioventing systems. Optimization of full-scale and multiple VW systems requires pilot testing to determine the volume of soil that can be oxygenated at a given flow rate and VW screen configuration.

Table 2.4 describes the change in soil gas oxygen levels that occurred during a 23-hour air injection test at the site. This air injection period at 48 acfm produced changes in soil gas oxygen levels at a distance of at least 35 feet from the central VW at all three monitored depth intervals. Oxygen level increases were measured at points near the VW (MPA and MPB), while decreases were measured further from the VW (MPC). The decreased oxygen levels observed at MPC, which originally contained oxygen, were the result of oxygen-deficient air from the more highly contaminated central portion of the site being forced outward by the injected air. The decrease in oxygen levels indicates significant air movement through the soils, and it is likely that oxygenated air will reach MPC with continuous injection. Based on measured pressure response, which is an indicator of long-term oxygen transport, it is anticipated that the radius of influence for a long-term bioventing system at this site will exceed 35 feet at all depths. Monitoring during the extended pilot test at this site will better define the effective treatment radius.

### 2.3.4 In Situ Respiration Rates

*In situ* respiration testing was performed at Site FC-2 according to protocol document procedures. Air was injected into MP screens MPA-13.5, MPB-9, MPB-13.5, and MPC-13.5 for 17.5 hours at a rate of approximately 1 acfm per screened interval to deliver oxygen to contaminated soils. At the end of the 17.5 hour period, air injection ceased and changes in soil gas composition were monitored over time. Oxygen, TVH, and carbon dioxide were measured over a period of 23 hours following the air injection period. The observed rates of oxygen utilization were then used to estimate the aerobic fuel degradation rates at Site FC-2. Figures 2.6 through 2.9 present the results of *in situ* respiration testing at the site, and Table 2.5 provides a summary of the observed oxygen utilization rates.

A 1.3-percent mixture of helium in air was injected into the MPA-13.5 screened interval, and then the loss of helium was measured for 23 hours following air injection. Because helium is a conservative, inert gas, the change in helium concentrations over time can be useful in determining if oxygen diffusion is responsible for a portion of the oxygen lost from each MP, or if leakage is occurring due to improper MP construction. Figure 2.10 compares oxygen utilization and helium retention at MPA-13.5. Helium levels remained constant at approximately 1 percent throughout the test, while oxygen concentrations at MPA-13.5 declined rapidly with time. Because the observed helium loss was negligible, and because helium will diffuse approximately three times faster than oxygen, the measured oxygen loss can be attributed to bacterial respiration rather than diffusion or faulty MP construction.

**TABLE 2.4**  
**SITE FC-2**  
**INFLUENCE OF AIR INJECTION AT VENT WELL**  
**ON MONITORING POINT OXYGEN LEVELS**  
**KELLY AFB, TEXAS**

| MP | Distance<br>From VW (ft) | Depth(ft) | Initial O <sub>2</sub> (%) | Final O <sub>2</sub> (%) <sup>a/</sup> |
|----|--------------------------|-----------|----------------------------|--|
| A  | 10.35                    | 4         | 0.1                        | 20.4                                   |
| A  | 10.35                    | 9         | 1.0                        | 17.4                                   |
| A  | 10.35                    | 13.5      | 1.0                        | 9.8                                    |
| B  | 19.60                    | 4         | 10.0                       | 18.8                                   |
| B  | 19.60                    | 9         | 0.3                        | 6.7                                    |
| B  | 19.60                    | 13.5      | 0.5                        | 8.7                                    |
| C  | 34.75                    | 4         | 0.8                        | 0.0                                    |
| C  | 34.75                    | 9         | 2.1                        | 0.2                                    |
| C  | 34.75                    | 13.5      | 0.7                        | 0.0                                    |

a/ Duration of air injection = 23 hours.

**TABLE 2.5**  
**SITE FC-2**  
**OXYGEN UTILIZATION RATES**  
**KELLY AFB, TEXAS**

| MP       | O <sub>2</sub> Loss <sup>a/</sup><br>(%) | Test<br>Duration<br>(min) | O <sub>2</sub> Utilization <sup>a/</sup><br>Rate<br>(%/min) |
|----------|--|---------------------------|---|
| MPA-13.5 | 11.5                                     | 280                       | 0.040   |
| MPB-9    | 15.6                                     | 750                       | 0.021   |
| MPB-13.5 | 12.1                                     | 500                       | 0.025   |
| MPC-13.5 | 11.1                                     | 280                       | 0.040   |

<sup>a/</sup> Values based on linear regression (Figures 2.6 through 2.9).

Figure 2.6  
Respiration Test  
Site FC-2 : MPA-13.5  
Kelly AFB, TX

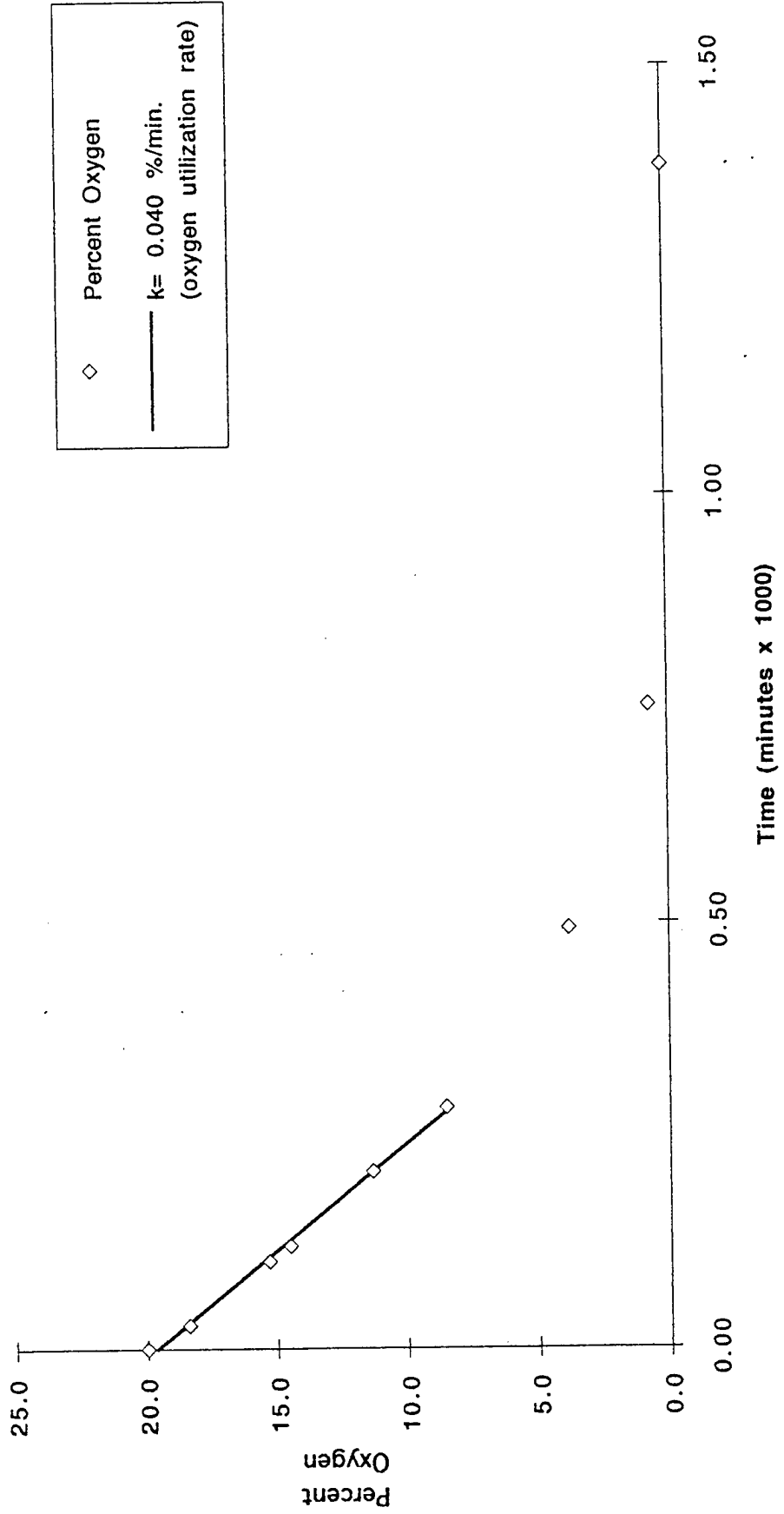

Figure 2.7  
Respiration Test  
Site FC-2 : MPB-9  
Kelly AFB, TX

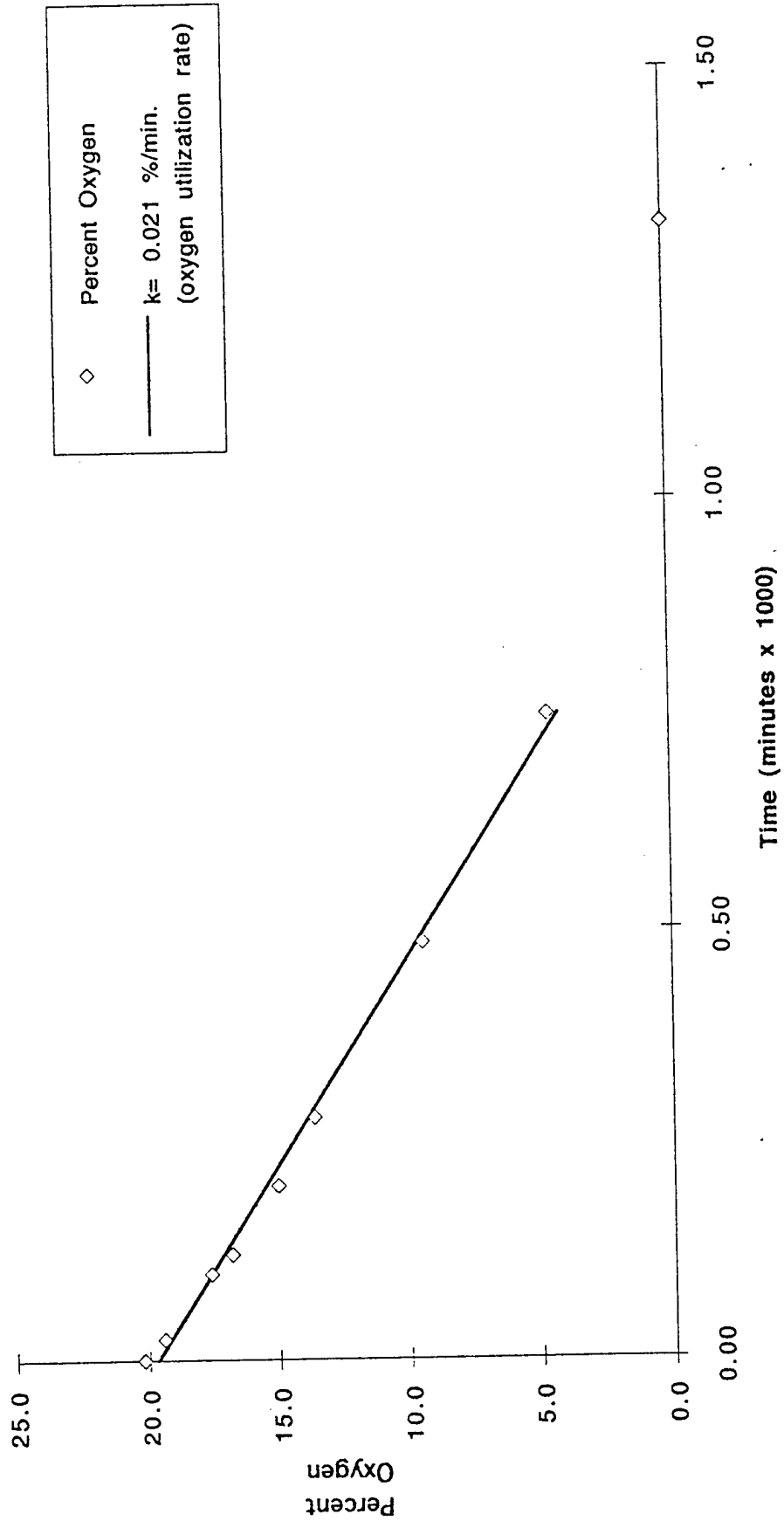

Figure 2.8  
Respiration Test  
Site FC-2 : MPB-13.5  
Kelly AFB, TX

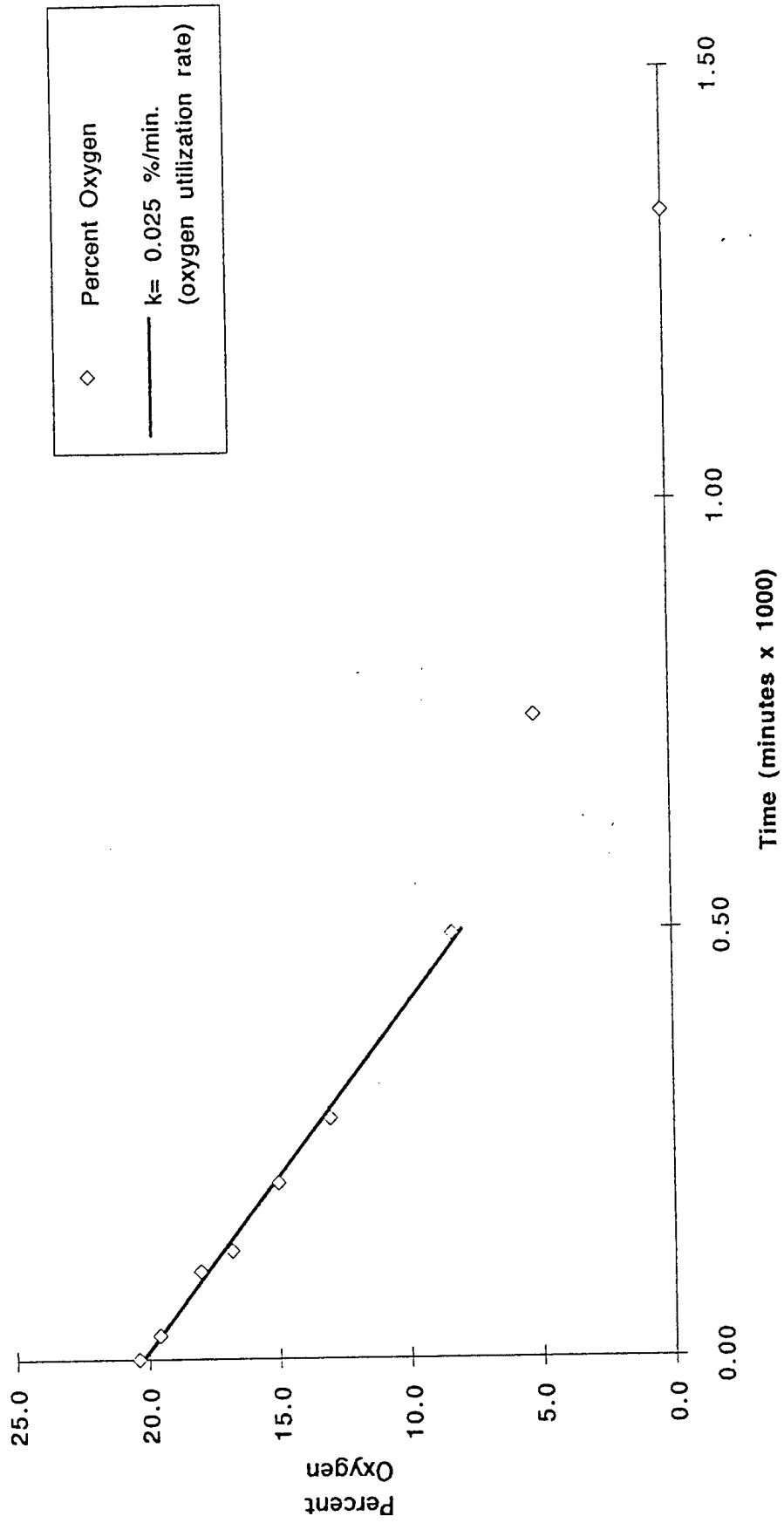

Figure 2.9  
Respiration Test  
Site FC-2 : MPC-13.5  
Kelly AFB, TX

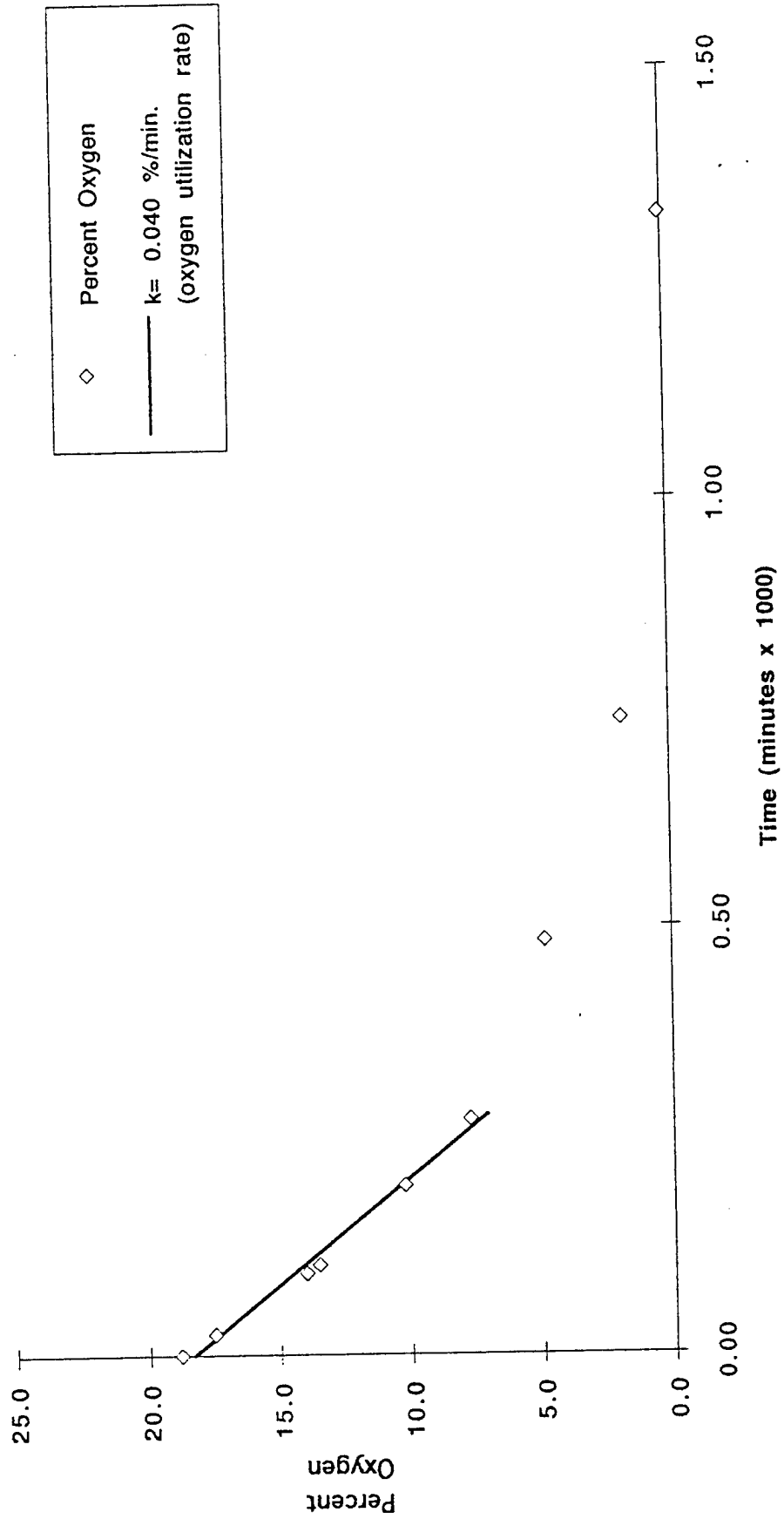
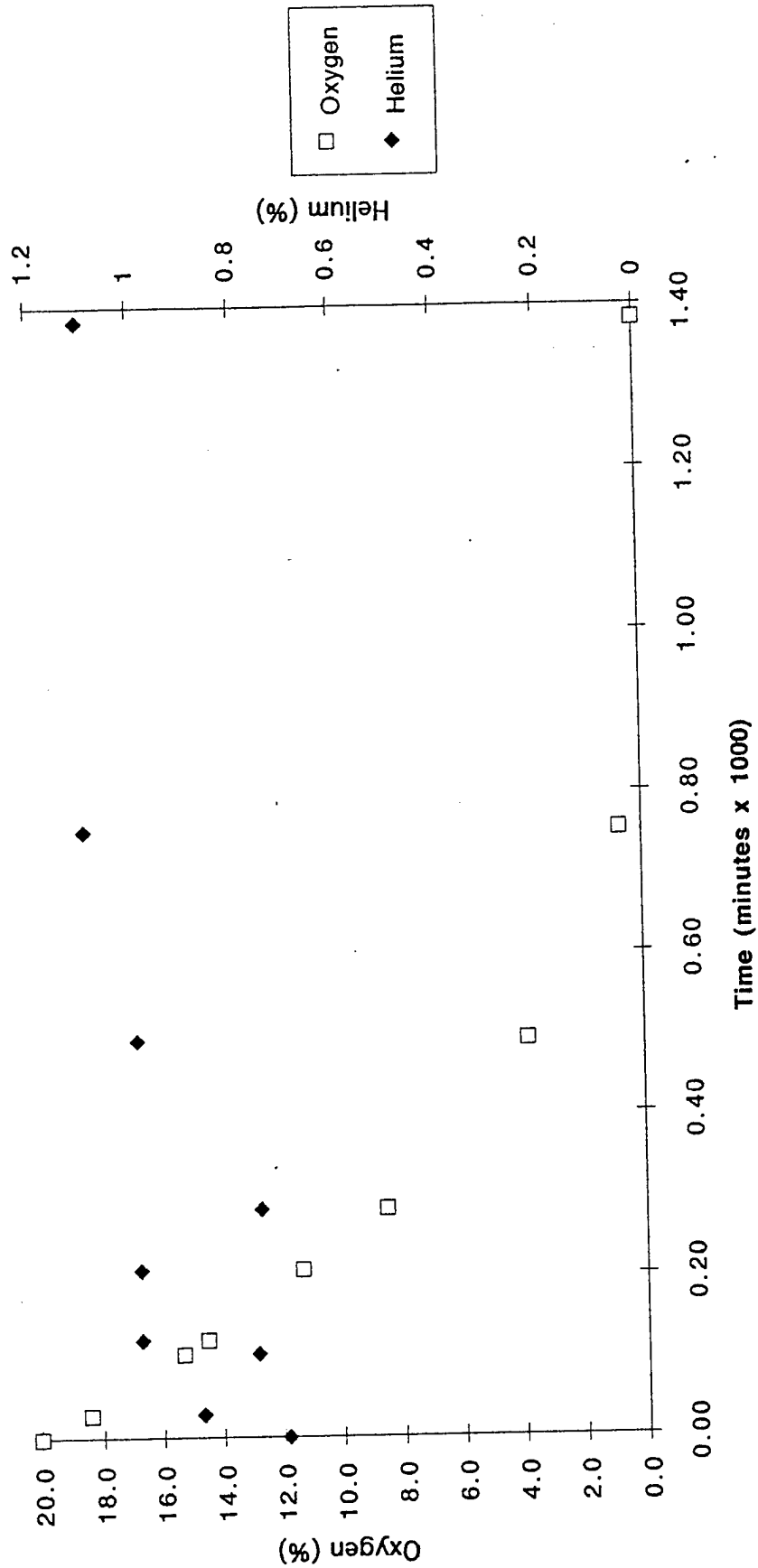

Figure 2.10  
 Respiration Test  
 Oxygen and Helium Concentrations  
 Site FC-2 : MPA-13.5  
 Kelly AFB, TX



At Site FC-2, an estimated 5,600 mg of fuel per kg of soil can be degraded each year. This value is the average of the fuel consumption rates calculated for every point at which a respiration test was conducted. The MP-specific fuel consumption rates were calculated using observed oxygen utilization rates, estimated air-filled porosities, and a conservative ratio of 3.5 mg of oxygen consumed for every 1 mg of fuel biodegraded. The air-filled porosity is calculated for each sampling point ranged from 0.083 to 0.1 liters of air per kilogram of soil.

Oxygen loss was rapid and linear at every MP during the early stages of the respiration test. Oxygen utilization rates observed at Site FC-2 ranged from 0.021 %/min to 0.040 %/min (Table 2.5). The oxygen utilization rates at MPA-13.5 and MPC-13.5 were approximately twice as great as those observed at MPB-9 and MPB-13.5. The difference in oxygen utilization rates is probably caused by differing contaminant concentrations at each location. At MPA-13.5, the laboratory TRPH concentration in the soil was 3,500 mg/kg (Table 2.1). In contrast, the laboratory TRPH concentration in a soil sample collected near MPB-13.5 was only 1,100 mg/kg. Because there is a smaller bacterial population available for fuel consumption at MPB, oxygen utilization rates are lower.

At all sampling points, the oxygen utilization rates appeared to decrease over time (Figures 2.6 through 2.9). This apparent decrease has been observed at other fuel spill sites where an oxygen source is in close proximity to contaminated soils. Site FC-2 is unpaved, and initial oxygen levels at the 4-foot MPs ranged from 2.7 to 12.8 percent (Table 2.2), suggesting the potential for oxygen diffusion from the surface. As oxygen is rapidly consumed by fuel-degrading bacteria in deeper contaminated soils, the oxygen diffusion gradient between the contaminated soil and the atmosphere becomes substantial. As a result, oxygen begins to diffuse from the atmosphere into the contaminated soils. This inward oxygen diffusion temporarily masks the actual bacterial oxygen uptake rates. Because fuel biodegradation generally consumes oxygen at a rate that exceeds diffusion, the oxygen concentrations soon return to zero in contaminated soils.

### **2.3.5 Potential Air Emissions**

Soil concentrations of BTEX compounds detected were less than 53 mg/kg (Table 2.1). Based on these BTEX concentrations, the long-term potential for air emissions from full-scale bioventing operations at this site is moderate. No benzene was detected in soil samples, although some benzene still exists in soil gas. Initial emissions should be minimal because accumulated vapors will move slowly outward from the air injection point and will be biodegraded as they move horizontally through the soil. During the air permeability test, air was injected at 48 acfm. Health and safety PID air monitoring of the breathing zone at the site did not indicate that hydrocarbon concentrations had increased above 1 ppmv during the test.

## **2.4 RECOMMENDATIONS**

Initial bioventing tests at this site indicate that oxygen has been depleted in the contaminated soils, and that air injection is an effective method of stimulating

aerobic fuel biodegradation. AFCEE has recommended that air injection continue at this site to determine the long-term radius of oxygen influence and the effect of time, available nutrients, and changing temperatures on fuel biodegradation rates.

A 2.5-horsepower regenerative blower has been installed at the site for continuous air injection. In June 1993, ES will return to the site to sample and analyze the soil gas and conduct a repeat respiration test. In December 1993, a final respiration test will be conducted, and soil and soil gas samples will be collected from the site to determine the degree of remediation achieved during the first year of *in situ* treatment.

Based on the results of the first year of pilot-scale bioventing, AFCEE will recommend one of three options:

1. Upgrade, if necessary, and continue operation of the bioventing system for full-scale remediation of the site. AFCEE can assist the base in obtaining regulatory approval for upgrading and continued operation.
2. If final soil sampling indicates significant contaminant removal has occurred, AFCEE may recommend additional sampling to confirm that cleanup criteria have been achieved.
3. If significant difficulties or poor results are encountered during bioventing at this site, AFCEE may recommend removal of the blower system and proper abandonment of the VW and MPs.

### 3.0 REFERENCES

Hinchee, R.E., S.K. Ong, R.N. Miller, D.C. Downey, and R. Frandt. 1992. *Test Plan and Technical Protocol for a Field Treatability Test for Bioventing*. Prepared for USAF Center for Environmental Excellence. May.

**APPENDIX A**  
**O&M INSTRUCTIONS**

## APPENDIX A

### OPERATION AND MAINTENANCE INSTRUCTIONS

#### 1.0 BLOWER/MOTOR MAINTENANCE

Gast® regenerative blowers have been installed at Site S-4 and Site FC-2. Model R4110-50 is in operation at Site S-4, and Model R5125Q-50 at Site FC-2. The blower performance curves for models R4110A-2 and R5125Q-2 have been included, and are identical to those of models R4110-50 and R5125Q-2, respectively. The blower and motor are relatively maintenance free. There is no lubrication required because the blower and motor have sealed bearings. If a blower system is in need of repair, please contact John Ratz of Engineering-Science, Inc. (ES) in Denver, Colorado at (303) 831-8100.

#### 2.0 FILTER MAINTENANCE

To avoid damage caused by passing solids through the blower, an air filter has been installed inline before the blower. By design, Gast® regenerative blowers are able to ingest small quantities of particles without damage. However, continuous ingestion of solids will damage or imbalance the impellers. The inline air filter will prevent solids from entering the blower and is rated at 99 percent efficiency to 10 microns.

The filter element is a polyester cloth and is cleanable and replaceable. The filter should be checked weekly for the first 2 months of operation. The air filter should be cleaned or replaced when the pressure difference across the filter reaches 15 to 20 inches of water. It will be the responsibility of Kelly Air Force Base (AFB) personnel to determine the best schedule for filter cleaning and/or replacement depending on the results of the initial observations.

The filter can be checked after turning off the blower system. To remove the filter, loosen the clamps, lift the metal top off of the air filter, and lift the air filter from the metal housing. When replacing the filter, be careful to ensure that the rubber seals remain in place. ES has provided Kelly AFB with a supply of air filters for the next year of blower operation. Should additional air filters be required, they can be ordered from Solberg Manufacturing, Inc. in Itasca, Illinois. Their phone number is (708) 773-1363. It is recommended that Kelly AFB keep a spare air filter at each site.

### 3.0 BLOWER PERFORMANCE MONITORING

To monitor the blower performance, vacuum, pressure, and temperature must be measured. These data should be recorded on the data collection sheets provided. All measurements will be taken at the same time while the system is running.

#### 3.1 Pressure/Vacuum

Open the shed roof and record the pressure and vacuum readings directly from the gauges in inches of water. Pressure readings are necessary to determine design parameters, and to verify that the blower is operating correctly. Vacuum readings are necessary to assure that the filter is clean. Record the measurements on the data collection sheet provided.

#### 3.2 Temperature

Open the shed roof and record the temperature readings directly from the gauges in degrees Fahrenheit. Record the measurements on the data collection sheet provided. Temperature readings are necessary to verify that the blower is operating correctly. The temperature should remain relatively constant with time. Should the temperature rise substantially in a short period of time, a problem may exist within the blower. Ambient air temperature fluctuations will affect the temperature readings but the temperature rise across the blower should not vary by more than 20°F.

### 4.0 MONITORING SCHEDULE

The following monitoring schedule is recommended for this system. During the initial months of operation, more frequent monitoring is recommended to ensure that any start up problems are quickly corrected. Data collection sheets have been provided for use by Kelly AFB personnel during data collection.

| <u>Monitoring Item</u>        | <u>Monitoring Frequency</u>   |
|-------------------------------|---|
| Blower vacuum and temperature | Weekly.   |
| Filter change                 | As required. When vacuum across filter exceeds 15 inches of H <sub>2</sub> O. |

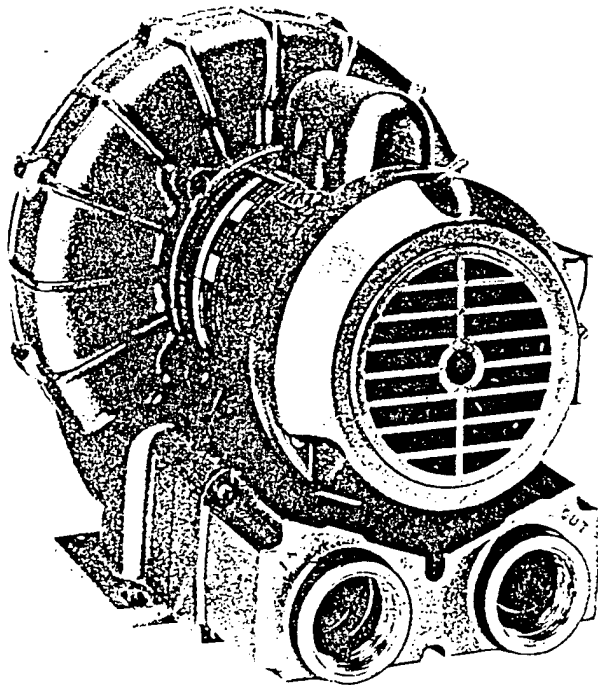

**MODEL R4110-2**  
48" H<sub>2</sub>O MAX. VAC., 88 CFM OPEN FLOW

### PRODUCT FEATURES

- Oilless operation
- TEFC motor mounted
- Can be mounted in any plane
- Rugged construction/low maintenance
- Can be operated blanked-off

### COMMON MOTOR OPTIONS

- 115/208-230V, 60 Hz; 110/220-240V, 50 Hz, single phase
- 208-230/460V, 60 Hz; 190-230 380-415V, 50 Hz, three phase
- 575V, 60 Hz, three phase

### RECOMMENDED ACCESSORIES

- Vacuum gauge AJ497
- Automotive-type filter AG337
- Muffler AJ121D
- Relief valve AG258

Various brand name motors are used on any model at the discretion of Gast Mfg. Corp.

### Important Notice:

Pictorial and dimensional data is subject to change without notice.

### Product Dimensions Metric (mm) U.S. Imperial (inches)

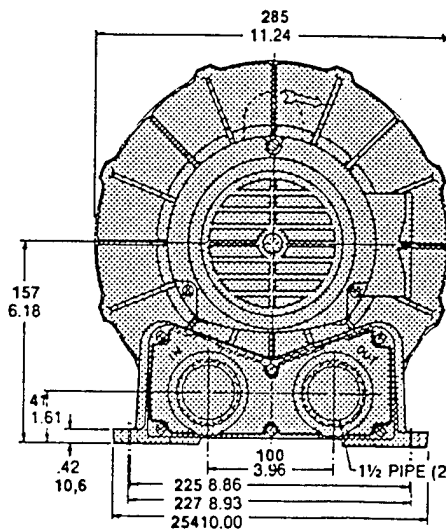
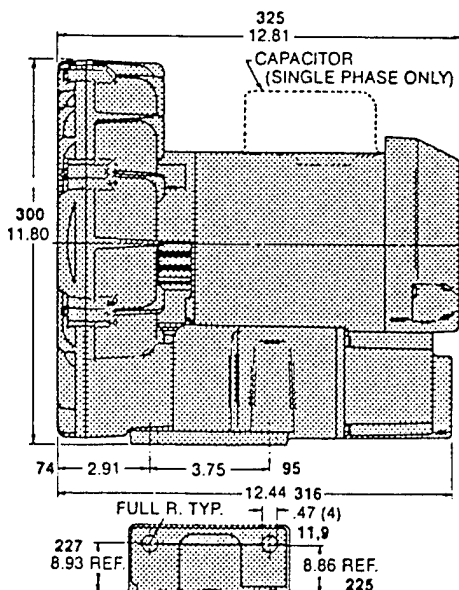

## Product Specifications

| Model Number | Hz | Motor Specs          | HP  | RPM  | Max Vac           |      | Max Flow |                  | Net Wt. |      |
|--------------|----|----------------------|-----|------|-------------------|------|----------|------------------|---------|------|
|              |    |                      |     |      | "H <sub>2</sub> O | mbar | cfm      | m <sup>3</sup> h | lbs.    | kg   |
| R4110-2      | 50 | 110/220-240-50-1     | 0.6 | 2850 | 34                | 924  | 72       | 122              | 41      | 18.6 |
|              | 60 | 115/208-230-60-1     | 1.0 | 3450 | 48                | 895  | 88       | 150              |         |      |
| R4310A-2     | 50 | 190-220/380-415-50-3 | 0.6 | 2850 | 34                | 924  | 72       | 122              | 41      | 18.6 |
|              | 60 | 208-230/460-3        | 1.0 | 3450 | 48                | 895  | 88       | 150              |         |      |

## Product Performance (Metric U.S. Imperial)

Black line on curve is for 60 cycle performance.  
Blue line on curve is for 50 cycle performance.

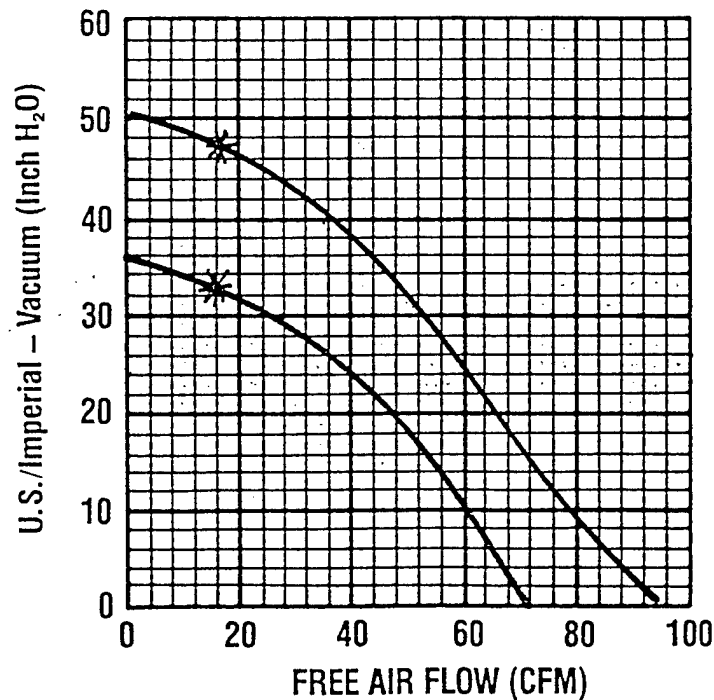
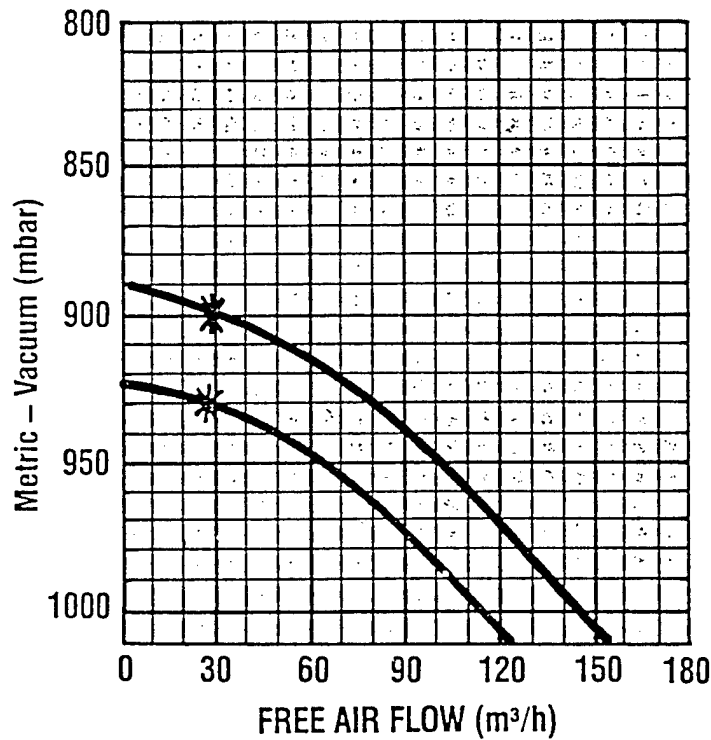

\*Maximum achievable static pressure under continuous operation.

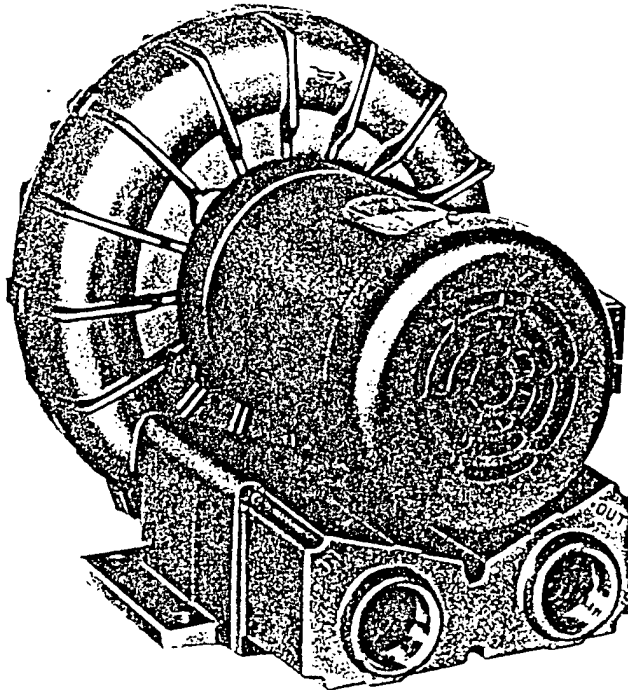

**MODEL R5325A-2**  
60" H<sub>2</sub>O MAX. VAC., 145 CFM OPEN FLOW

### PRODUCT FEATURES

- Oilless operation
- TEFC motor mounted
- Can be mounted in any plane
- Rugged construction-low maintenance

### COMMON MOTOR OPTIONS

- 115/208-230V, 60 Hz, single phase
- 208-230/460V, 60 Hz: 190-220/380-415V, 50 Hz, three phase
- 575V, 60 Hz, three phase

### RECOMMENDED ACCESSORIES

- Vacuum gauge AJ497
- Automotive-type filter AG337
- Muffler AJ121D
- Relief valve AG258

Various brand name motors are used on any model at the discretion of Gast Mfg. Corp.

### Important Notice:

Pictorial and dimensional data is subject to change without notice.

### Product Dimensions Metric (mm) U.S. Imperial (inches)

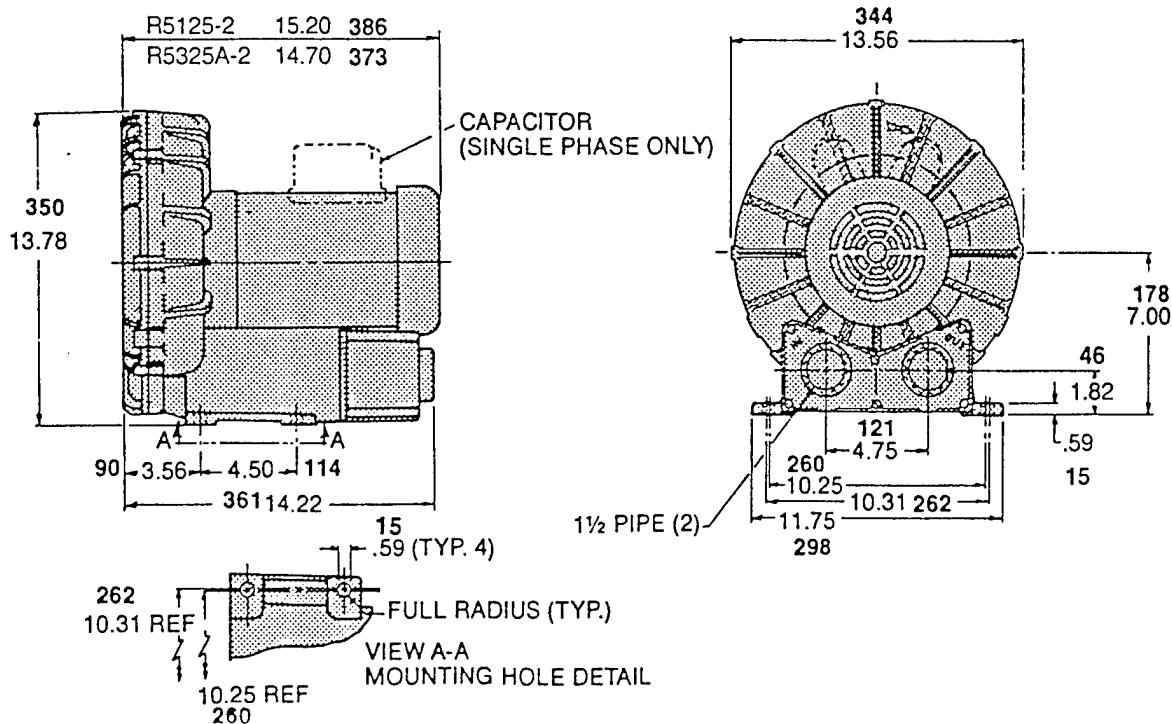

## Product Specifications

| Model Number | Hz | Motor Specs          | HP   | RPM  | Max Vac           |      | Max Flow |                  | Net Wt. |      |
|--------------|----|----------------------|------|------|-------------------|------|----------|------------------|---------|------|
|              |    |                      |      |      | "H <sub>2</sub> O | mbar | cfm      | m <sup>3</sup> h | lbs.    | kg   |
| R5325A-2     | 50 | 190-220/380-415-50-3 | 1.35 | 2850 | 47                | 897  | 120      | 204              | 65      | 29,5 |
|              | 60 | 208-230/460-3        | 2.5  | 3450 | 60                | 865  | 145      | 246              |         |      |
| R5125-2      | 60 | 115/208-230-60-1     | 2.5  | 3450 | 60                | 865  | 145      | 246              | 65      | 29,5 |

Product Performance (Metric U.S. Imperial) Black line on curve is for 60 cycle performance.  
Blue line on curve is for 50 cycle performance.

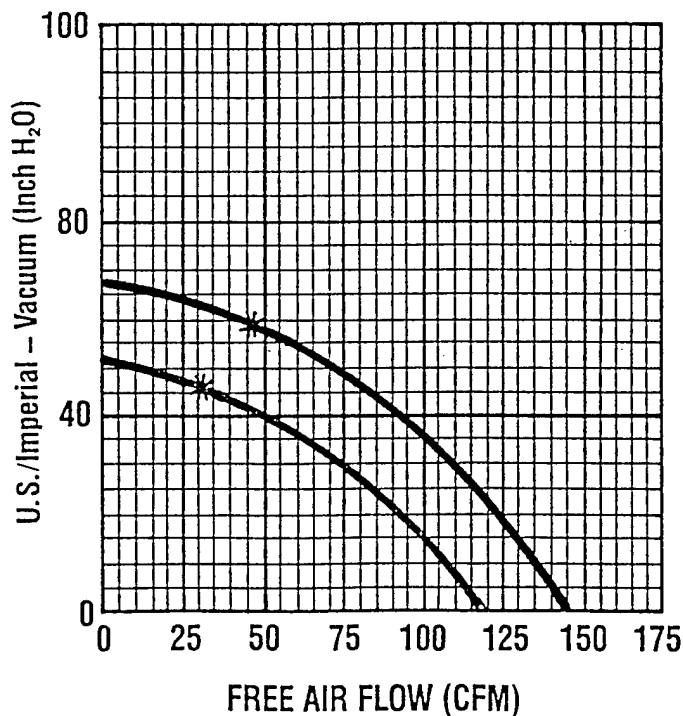
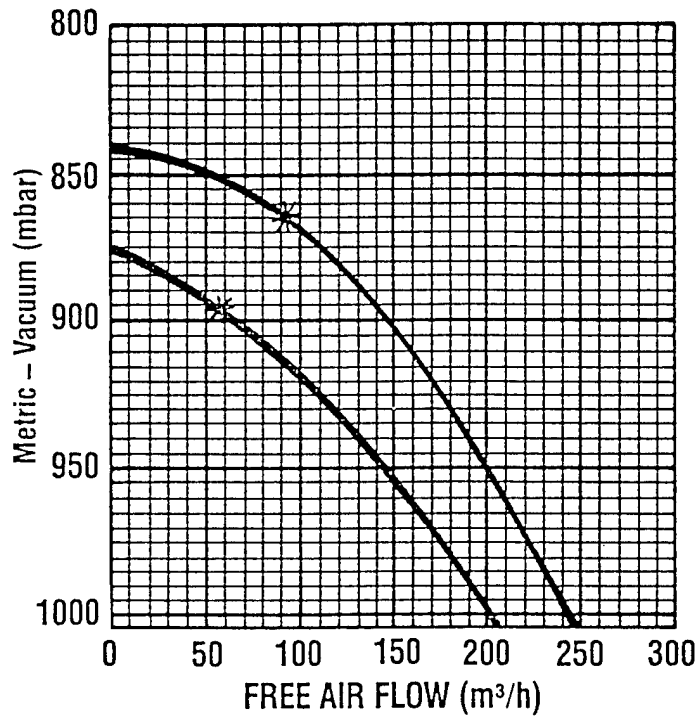

\*Minimum flow permissible through the unit for trouble-free, continuous operation.



**APPENDIX B**

**GEOLOGIC BORING LOGS**  
**AND**  
**CHAIN-OF-CUSTODY FORMS**

Client \_\_\_\_\_

Job No. \_\_\_\_\_

Sheet \_\_\_\_ of \_\_\_\_

Subject \_\_\_\_\_

By \_\_\_\_\_

Date \_\_\_\_\_

Checked \_\_\_\_\_

Rev. \_\_\_\_\_

S-4 MP CONSTRUCTION

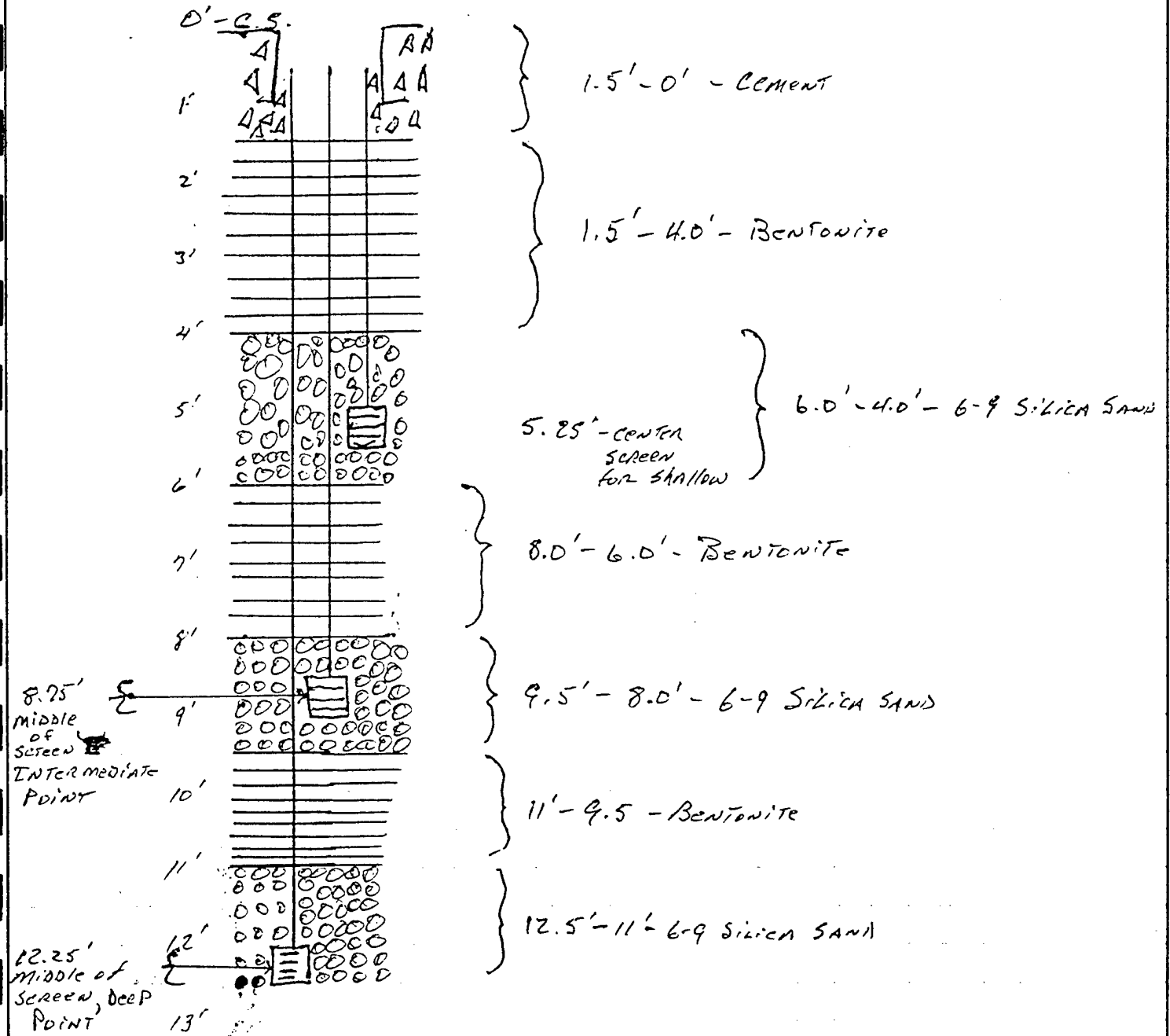

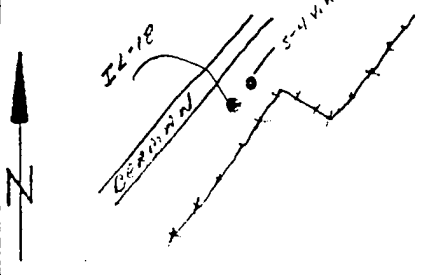

|                 |                           |                 |                                    |
|-----------------|---------------------------|-----------------|------------------------------------|
| WELL NUMBER     | S-4 Vent Well             | LOCATION        | Berman Road                        |
| DATE            | 12-10-92                  | WEATHER         | Clear, Temp. 70's                  |
| LOGGED BY       | J. PAULIK                 | DRILLED BY      | JOHN'S EQUIPMENT CO.               |
| DRILLING METHOD | 6.25" Hollow-Stem Access  | SAMPLING METHOD | 1.5' California Sampler            |
| GRAVEL PACK     | 17'-6' (10-9) SILICA SAND | SEAL            | 6-1.5' Bentonite<br>1.5'-0' Cement |

|        |                      |          |       |          |     |           |             |     |
|--------|----------------------|----------|-------|----------|-----|-----------|-------------|-----|
| CASING | TYPE Schedule 40 PVC | DIAMETER | 4"    | LENGTH   | 10' | HOLE DIA. | 11"         |     |
| SCREEN | TYPE Schedule 40     | SLOT     | 0.04" | DIAMETER | 4"  | LENGTH    | 10'         |     |
|        |                      |          |       |          |     |           | TOTAL DEPTH | 17' |

| MOISTURE CONTENT | SORTING | DENSITY | PLASTICITY   | SAMPLE NUMBER | TIP READING (PPM) | DEPTH | SAMPLE RECOVERY | PENETRATION RESISTANCE | LITHOLOGY/REMARKS  | WELL COMPLETION |
|------------------|---------|---------|--------------|---------------|-------------------|-------|-----------------|------------------------|--|-----------------|
|                  |         |         |              |               |                   | 0     |                 |                        | <p>Note: Samples were collected from selected intervals using a California Sampler. All other lithology descriptions are from cuttings.</p> <p>0'-3.5' - (cuttings) Clay, black, little to some fine gravel, limestone</p> |                 |
|                  |         |         |              |               | 1                 |       |                 |                        |  |                 |
|                  |         |         |              |               | 2                 |       |                 |                        |  |                 |
| Moist            |         |         | Soft Plastic |               |                   | 3     |                 |                        | <p>0.00'-0.67' - Clay, Gray, some black mottling, little to some silt, trace of fine limestone gravel.</p>   |                 |
| Moist            |         |         | Soft Plastic | 1             | 51                | 0.47  | 4               |                        |  |                 |
|                  |         |         |              |               |                   | 5     |                 | 6                      |  |                 |
| Moist            |         |         | Soft Plastic |               |                   | 6     |                 |                        | <p>5.0'-8.5' (cuttings) Clay, Gray, some black mottling, trace to little silt trace of fine limestone gravel.</p>  |                 |
|                  |         |         |              |               |                   | 7     |                 |                        |  |                 |
|                  |         |         |              |               |                   | 8     |                 |                        |  |                 |
| Moist            |         |         | Soft Plastic |               |                   | 9     |                 | 12                     | <p>0.00'-0.84' - Clay, gray to dark gray, little silt and fine limestone gravel.</p>   |                 |
|                  |         |         |              | 2             | 59                | 0.84  | 11              |                        |  |                 |
|                  |         |         |              |               |                   | 10    |                 | 6                      |  |                 |
| Moist            |         |         | Soft Plastic |               |                   | 11    |                 |                        | <p>10'-13.5' - (cuttings) Clay, same as above, becoming dark gray and sticky.</p>  |                 |
|                  |         |         |              |               |                   | 12    |                 |                        |  |                 |
|                  |         |         |              |               |                   | 13    |                 |                        |  |                 |
| SATURATED POOR   |         |         |              |               |                   | 14    |                 | 90                     | <p>0.00'-0.50' - Gravel, clean, fine to coarse, little clay and silt.</p>  |                 |
|                  |         |         |              | 3             |                   | 0.50  | 150             |                        |  |                 |
|                  |         |         |              |               |                   | 15    |                 |                        |  |                 |
|                  |         |         |              |               |                   | 16    |                 |                        |  |                 |
|                  |         |         |              |               |                   | 17    |                 |                        |  |                 |
|                  |         |         |              |               |                   | 18    |                 |                        |  |                 |
|                  |         |         |              |               |                   | 19    |                 |                        |  |                 |
|                  |         |         |              |               |                   | 20    |                 |                        |  |                 |

|             |           |        |             |
|-------------|-----------|--------|-------------|
| EXPLANATION | GROUT     | SAND   | SCREEN      |
|             | BENTONITE | CASING | WATER LEVEL |

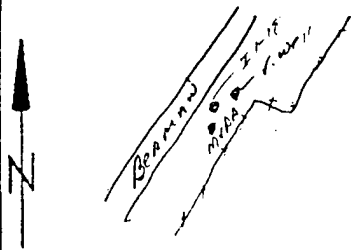

|                 |                           |                 |                           |
|-----------------|---------------------------|-----------------|---------------------------|
| WELL NUMBER     | ▶ 5-4 MPA                 | LOCATION        | ▶ BERMAN ROAD             |
| DATE            | ▶ 12-10-92                | WEATHER         | ▶ CLEAR, TEMP. 60'S       |
| LOGGED BY       | ▶ J. PAWLAK               | DRILLED BY      | ▶ JAMES ENVIK, DRLG.      |
| DRILLING METHOD | ▶ 4.25" Hollow-Stem Auger | SAMPLING METHOD | ▶ 1.5' California Sampler |
| GRAVEL PACK     | ▶ See Well Completion     | SEAL            | ▶ See Well Completion     |

|        |        |          |          |                  |
|--------|--------|----------|----------|------------------|
| CASING | ▶ TYPE | DIAMETER | LENGTH   | HOLE DIA. 8"     |
| SCREEN | ▶ TYPE | SLOT     | DIAMETER | LENGTH           |
|        |        |          |          | TOTAL DEPTH 125' |

| MOISTURE CONTENT | SORTING | DENSITY | PLASTICITY   | SAMPLE NUMBER | TIP READING (PPM) | DEPTH | SAMPLE RECOVERY | PENETRATION RESISTANCE | LITHOLOGY/REMARKS   | WELL COMPLETION |
|------------------|---------|---------|--------------|---------------|-------------------|-------|-----------------|------------------------|---|-----------------|
|                  |         |         |              |               |                   | 0     |                 |                        | <p>NOTE: Samples were collected from selected intervals using a California sampler. All other lithology descriptions are from cuttings.</p> <p>0'-3.5' - Clay, black and Gravel, fine to coarse.</p> <p>4.00'-0.10' - Gravel, limestone, fine to coarse.</p> <p>0.10'-0.52' - Clay, dark gray, tan mottled, little silt and fine gravel.</p> <p>5'-8' - (cuttings) Clay same as above.</p> <p>8.00'-0.33' - Gravel, chert and limestone, fine to coarse.</p> <p>0.10'-0.68' - Clay, black to dark gray, trace of silt, sticky.</p> <p>9.5'-11.5' (cuttings) same as above clay.</p> <p>0.00'-0.80' - Clay, dark gray, sticky, trace to little silt and fine gravel.</p> |                 |
| Moist            |         |         | Soft Plastic |               |                   |       |                 |                        |   |                 |
| Moist            |         |         | Soft Plastic | 1             | 1                 | 4     | 5               |                        |   |                 |
|                  |         |         |              |               |                   | 5     | 9               |                        |   |                 |
| Moist            |         |         | Soft Plastic |               |                   | 6     |                 |                        |   |                 |
| Moist Free       | Loose   |         |              | 2             | 42                | 8     | 9               |                        |   |                 |
| Moist to wet     |         |         | Soft Plastic |               |                   | 9     | 6               |                        |   |                 |
|                  |         |         |              |               |                   | 10    |                 |                        |   |                 |
|                  |         |         |              |               |                   | 11    |                 |                        |   |                 |
| Moist            |         |         | Soft Plastic | 3             | 48                | 12    | 3               |                        |   |                 |
|                  |         |         |              |               |                   | 13    | 4               |                        |   |                 |
|                  |         |         |              |               |                   | 14    | 10              |                        |   |                 |
|                  |         |         |              |               |                   | 15    |                 |                        |   |                 |
|                  |         |         |              |               |                   | 16    |                 |                        |   |                 |
|                  |         |         |              |               |                   | 17    |                 |                        |   |                 |
|                  |         |         |              |               |                   | 18    |                 |                        |   |                 |
|                  |         |         |              |               |                   | 19    |                 |                        |   |                 |
|                  |         |         |              |               |                   | 20    |                 |                        |   |                 |

|             |           |        |             |
|-------------|-----------|--------|-------------|
| EXPLANATION | GROUT     | SAND   | SCREEN      |
|             | BENTONITE | CASING | WATER LEVEL |

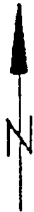

|                 |                                   |                 |                         |
|-----------------|-----------------------------------|-----------------|-------------------------|
| WELL NUMBER     | 5-4 MVP-B                         | LOCATION        | BERMAN ROAD             |
| DATE            | 12-11-92                          | WEATHER         | Clear, Temp. 60's       |
| LOGGED BY       | J. Pawlik                         | DRILLED BY      | Jones Envir. Drle.      |
| DRILLING METHOD | 4.25" Hollow-Stem Pipe            | SAMPLING METHOD | 1.5' California Sampler |
| GRAVEL PACK     | See Well Completion for 5-4 MVP-A | SEAL            |                         |

|        |      |          |          |           |                   |
|--------|------|----------|----------|-----------|-------------------|
| CASING | TYPE | DIAMETER | LENGTH   | HOLE DIA. | 8"                |
| SCREEN | TYPE | SLOT     | DIAMETER | LENGTH    | TOTAL DEPTH 12.5' |

| MOISTURE CONTENT | SORTING      | DENSITY | PLASTICITY                  | SAMPLE NUMBER | TIP READING (PPM) | DEPTH | SAMPLE RECOVERY | PENETRATION RESISTANCE | LITHOLOGY/REMARKS  | WELL COMPLETION                   |
|------------------|--------------|---------|-----------------------------|---------------|-------------------|-------|-----------------|------------------------|--|-----------------------------------|
|                  |              |         |                             |               |                   | 0     |                 |                        | <p>Note; Samples were collected from selected intervals using a California Sampler. All other lithology descriptions are from cuttings.</p> <p>0'-2.5' - (cuttings) Gravel, limestone, fine and coarse, little clay, brown to gray.</p> <p>0.00'-0.15' - GRAVEL, same as Above</p> <p>0.15'-0.49' - Clay, gray to dark gray, little to some silt, trace of fine gravel.</p> <p>5'-8.5' - Clay, same as Above</p> <p>0.00'-0.79' - Clay, gray to dark gray, little to some silt, trace of fine gravel.</p> <p>10'-11.5' (cuttings) Clay, dark gray, little silt and fine gravel.</p> <p>0.00'-1.5' - Clay, light gray, little to some fine gravel and silt.</p> | See Well Completion for 5-4 MVP-A |
| Moist            | Soft to Hard |         | Plastic to non-plastic      |               |                   | 1     |                 |                        |  |                                   |
| Moist            | Soft         |         | Plastic                     | 1             | 40                | 2     | 7               |                        |  |                                   |
|                  |              |         |                             |               |                   | 3     | 8               |                        |  |                                   |
|                  |              |         |                             |               |                   | 4     | 9               |                        |  |                                   |
| Moist            | Soft         |         | Plastic                     |               |                   | 5     |                 |                        |  |                                   |
|                  |              |         |                             |               |                   | 6     |                 |                        |  |                                   |
|                  |              |         |                             |               |                   | 7     |                 |                        |  |                                   |
|                  |              |         |                             |               |                   | 8     |                 |                        |  |                                   |
| Moist            | Soft         |         | Plastic                     | 2             | 52                | 9     | 4               |                        |  |                                   |
|                  |              |         |                             |               |                   | 10    | 5               |                        |  |                                   |
|                  |              |         |                             |               |                   | 11    | 6               |                        |  |                                   |
| Moist            | Soft         |         | Plastic                     |               |                   | 12    |                 |                        |  |                                   |
|                  |              |         |                             |               |                   | 13    | 5               |                        |  |                                   |
| Moist            | Soft         |         | Slightly Plastic to Plastic | 3             | 190               | 14    | 5               |                        |  |                                   |
|                  |              |         |                             |               |                   | 15    | 6               |                        |  |                                   |
|                  |              |         |                             |               |                   | 16    |                 |                        |  |                                   |
|                  |              |         |                             |               |                   | 17    |                 |                        |  |                                   |
|                  |              |         |                             |               |                   | 18    |                 |                        |  |                                   |
|                  |              |         |                             |               |                   | 19    |                 |                        |  |                                   |
|                  |              |         |                             |               |                   | 20    |                 |                        |  |                                   |

|             |           |        |             |
|-------------|-----------|--------|-------------|
| EXPLANATION | GROUT     | SAND   | SCREEN      |
|             | BENTONITE | CASING | WATER LEVEL |

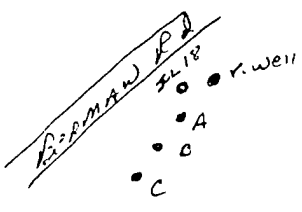

|                 |   |                 |                           |
|-----------------|---|-----------------|---------------------------|
| WELL NUMBER     | ▶ 5-4 MVPC                                | LOCATION        | ▶ BERMAN ROAD             |
| DATE            | ▶ 12-11-92                                | WEATHER         | ▶ Partly Cloudy, Temp 60° |
| LOGGED BY       | ▶ J. Pawlik                               | DRILLED BY      | ▶ Jones Envir. Dr. Co.    |
| DRILLING METHOD | ▶ 4.25" Hollow-stem Auger                 | SAMPLING METHOD | ▶ 1.5" Split-Spoon        |
| GRAVEL PACK     | ▶ See 5-4 MPA for Vapour Print Completion | SEAL            | ▶                         |

|        |        |          |          |           |                   |
|--------|--------|----------|----------|-----------|-------------------|
| CASING | ▶ TYPE | DIAMETER | LENGTH   | HOLE DIA. | 8"                |
| SCREEN | ▶ TYPE | SLOT     | DIAMETER | LENGTH    | TOTAL DEPTH 12.5' |

| MOISTURE CONTENT | SORTING | DENSITY | PLASTICITY               | SAMPLE NUMBER | TIP READING (PPH) | DEPTH | SAMPLE RECOVERY | PENETRATION RESISTANCE | LITHOLOGY/REMARKS  | WELL COMPLETION                    |
|------------------|---------|---------|--------------------------|---------------|-------------------|-------|-----------------|------------------------|--|------------------------------------|
|                  |         |         |                          |               |                   | 0     |                 |                        | Note: Samples were collected from selected intervals using a 1.5' split-spoon. All other lithology descriptions are from cuttings. | See well completion for 5-4 MVPC-A |
|                  |         |         |                          |               |                   | 1     |                 |                        |  |                                    |
| Moist            |         |         | Medium Silty Non Plastic |               |                   | 2     |                 |                        | 0'-3.5' - (cuttings) Clay, black and limestone gravel, fine to coarse  |                                    |
|                  |         |         |                          |               |                   | 3     |                 |                        |  |                                    |
| Moist            |         |         | Slightly Soft Plastic    | 1             | 170               | 4     | 0.60            | 4                      | 0.00'-0.60' - Clay, brown to black, little fine gravel, some silt.   |                                    |
|                  |         |         |                          |               |                   | 5     |                 | 4                      |  |                                    |
| Moist            |         |         | Slightly Soft Plastic    |               |                   | 6     |                 |                        | 5'-8' (cuttings) Clay same as above.   |                                    |
|                  |         |         |                          |               |                   | 7     |                 |                        |  |                                    |
| Moist            |         |         | Slightly Soft Plastic    | 2             | 135               | 8     |                 | 4                      | 0.00'-0.61' - Clay, gray to dark gray, little to some silt, little limestone gravel, fine.   |                                    |
|                  |         |         |                          |               |                   | 9     | 0.60            | 11                     |  |                                    |
|                  |         |         |                          |               |                   | 10    |                 |                        |  |                                    |
|                  |         |         |                          |               |                   | 11    |                 |                        |  |                                    |
| Moist            |         |         | Slightly Soft Plastic    | 3             | 1,000             | 12    | 0.60            | 20                     | 0.00'-0.15' - Clay same as above   |                                    |
|                  |         |         |                          |               |                   | 13    |                 | 15                     | 0.15'-0.80' - Chert and limestone gravel, fine to coarse, some silt, little clay.  |                                    |
| Sample for dense |         |         |                          |               |                   | 14    |                 |                        |  |                                    |
|                  |         |         |                          |               |                   | 15    |                 |                        |  |                                    |
|                  |         |         |                          |               |                   | 16    |                 |                        |  |                                    |
|                  |         |         |                          |               |                   | 17    |                 |                        |  |                                    |
|                  |         |         |                          |               |                   | 18    |                 |                        |  |                                    |
|                  |         |         |                          |               |                   | 19    |                 |                        |  |                                    |
|                  |         |         |                          |               |                   | 20    |                 |                        |  |                                    |

|             |        |             |        |
|-------------|--------|-------------|--------|
| EXPLANATION | GROUT  | SAND        | SCREEN |
| BENTONITE   | CASING | WATER LEVEL |        |

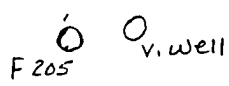

|  |   |
|--|---|
| WELL NUMBER ▶ FC-2 Vent Well               | LOCATION ▶ ADJACENT TO M.W. F205 FIRE TRAINING GROUND |
| DATE ▶ 12-9-92                             | WEATHER ▶ Clear, Temp. 60's                           |
| LOGGED BY ▶ J. Pawlik                      | DRILLED BY ▶ Jones Env. Drlg.                         |
| DRILLING METHOD ▶ 6.25" Hollow-stem Augers | SAMPLING METHOD ▶ 1.5' California Sampler             |
| GRAVEL PACK ▶ 19'-15.7' 6-9 silica sand    | SEAL ▶ 5.7'-1.5'-Bentonite<br>1.5'-0'-Cement          |

|                               |             |             |                 |
|-------------------------------|-------------|-------------|-----------------|
| CASING ▶ TYPE Schedule 40 PVC | DIAMETER 4" | LENGTH 9'   | HOLE DIA. 11"   |
| SCREEN ▶ TYPE Schedule 40     | SLOT 0.04"  | DIAMETER 4" | LENGTH 12.5'    |
|                               |             |             | TOTAL DEPTH 19' |

| MOISTURE CONTENT | SORTING | DENSITY | PLASTICITY             | SAMPLE NUMBER | TIP READING (PPL) | DEPTH | SAMPLE RECOVERY | PENETRATION RESISTANCE | LITHOLOGY/REMARKS   | WELL COMPLETION                          |
|------------------|---------|---------|------------------------|---------------|-------------------|-------|-----------------|------------------------|---|--|
|                  |         |         |                        |               |                   | 0     |                 |                        | NOTE: Samples were collected from selected intervals using a California <del>split</del> sampler. All other lithology descriptions are from cuttings. | +2' stick-up<br>Cement<br>TOP of B. Seal |
| Moist            |         | Soft    | Plastic                |               |                   | 1     |                 |                        |   |  |
|                  |         |         |                        |               |                   | 2     |                 |                        |   |  |
|                  |         |         |                        |               |                   | 3     |                 |                        | 0'-3.5'-(cuttings) Clay, black, little to some limestone gravel, little silt.   |  |
| Moist            |         | Hard    | Non-Plastic            | 1             | 1.35              | 4     | 9               | 17                     | 0.00'-1.35'- Clay, black and gravel, fine to coarse, limestone and chert.   | 5-40 ft<br>Pvc<br>4" dia                 |
|                  |         |         |                        |               |                   | 5     | 19              |                        |   |  |
|                  |         |         |                        |               |                   | 6     |                 |                        | 5'-8.5' (cuttings) Clay, black, little to some fine and coarse gravel, limestone, little silt.  | TOP of Gravel Pack                       |
| Moist            |         | Soft    | Plastic                |               |                   | 7     |                 |                        |   |  |
|                  |         |         |                        |               |                   | 8     |                 |                        |   |  |
| Moist            |         | Soft    | Plastic to Non-Plastic | 2             | 0.67              | 9     | 4               | 4                      | 0.00'-0.67'- Clay, black, trace to little silt and fine gravel, limestone.  |  |
|                  |         |         |                        |               |                   | 10    | 4               | 4                      |   |  |
|                  |         |         |                        |               |                   | 11    |                 |                        | 12'-13.5'-(cuttings)- This gravel bed AT 12', Clay, gray, some silt, little fine gravel.  |  |
| Moist            |         | Soft    | Slightly Plastic       |               |                   | 12    |                 |                        |   |  |
|                  |         |         |                        |               |                   | 13    |                 |                        |   |  |
| Moist            |         | Soft    | Slightly Plastic       | 3             | 150               | 14    | 7               | 15                     | 0.00'-0.47'- Clay, gray, some silt, little fine gravel, limestone   | 5-40<br>0.04"<br>Slot P<br>4" dia        |
|                  |         |         |                        |               |                   | 15    | 29              |                        |   |  |
|                  |         |         |                        |               |                   | 16    |                 |                        | 0.47'-1.50'- Silt, gray, some silt, trace to little fine gravel, trace of very fine-grained sand  |  |
|                  |         |         |                        |               |                   | 17    |                 |                        |   |  |
|                  |         |         |                        |               |                   | 18    |                 |                        |   |  |
|                  |         |         |                        |               |                   | 19    |                 |                        |   | PVC well cap<br>TD = 19'                 |
|                  |         |         |                        |               |                   | 20    |                 |                        |   |  |

|             |           |        |             |
|-------------|-----------|--------|-------------|
| EXPLANATION | GROUT     | SAND   | SCREEN      |
|             | BENTONITE | CASING | WATER LEVEL |

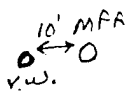
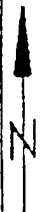

|                 |                          |                 |  |
|-----------------|--------------------------|-----------------|--|
| WELL NUMBER     | FC-2 MPA                 | LOCATION        | ADJACENT TO V. WELL FIRE TRAINING AREA |
| DATE            | 12-9-92                  | WEATHER         | Clear, Windy, Temp 90s                 |
| LOGGED BY       | J. Pawlik                | DRILLED BY      | Jones Environmental Co.                |
| DRILLING METHOD | 4.25" Hollow-Stem Augers | SAMPLING METHOD | 1.5' California Sampler                |
| GRAVEL PACK     | SEE Well Completion      | SEAL            | See Well Completion                    |

|        |      |          |          |           |                 |
|--------|------|----------|----------|-----------|-----------------|
| CASING | TYPE | DIAMETER | LENGTH   | HOLE DIA. | 8"              |
| SCREEN | TYPE | SLOT     | DIAMETER | LENGTH    | TOTAL DEPTH 14' |

| MOISTURE CONTENT | SORTING | DENSITY | PLASTICITY                  | SAMPLE NUMBER | TIP READING (FPL) | DEPTH | SAMPLE RECOVERY | PENETRATION RESISTANCE | LITHOLOGY/REMARKS   | WELL COMPLETION |
|------------------|---------|---------|-----------------------------|---------------|-------------------|-------|-----------------|------------------------|---|-----------------|
|                  |         |         |                             |               |                   | 0     |                 |                        | NOTE: Samples were collected from selective intervals using a California Sampler. All other lithology descriptions are from cuttings. | MANHOLE         |
|                  |         |         |                             |               |                   | 1     |                 |                        |   |                 |
|                  |         |         | Soft Plastic                |               |                   | 2     |                 |                        | 0' - 3.5' - (cuttings) Clay, black, some fine limestone gravel, plant roots.  |                 |
|                  |         |         |                             |               |                   | 3     |                 |                        |   |                 |
|                  |         |         | Med. Slightly Stiff Plastic | 1             | 34                | 4     | 12              | 12                     | 0.00' - 1.50' - Clay, black, some fine limestone gravel, trace of silt, plant parts.  |                 |
|                  |         |         |                             |               |                   | 5     | 14              |                        |   |                 |
|                  |         |         |                             |               |                   | 5     |                 |                        | 5' - 8.5' - Clay same as above.   |                 |
|                  |         |         | Med. Slightly Stiff Plastic |               |                   | 7     |                 |                        |   |                 |
|                  |         |         |                             |               |                   | 8     |                 |                        |   |                 |
|                  |         |         |                             |               |                   | 9     | 4               | 4                      | 0.00' - 0.70' - Clay, black, some silt, little limestone gravel.  |                 |
|                  |         |         | Soft Plastic                | 2             | 46                | 9     | 5               | 5                      |   |                 |
|                  |         |         |                             |               |                   | 10    | 7               |                        | 10' - 12.5' - (cuttings) Clay, same as above.   |                 |
|                  |         |         |                             |               |                   | 11    |                 |                        |   |                 |
|                  |         |         | Soft Plastic                |               |                   | 12    |                 |                        |   |                 |
|                  |         |         |                             |               |                   | 13    | 5               | 5                      | 0.00' - 0.80' - Clay, dark gray, some silt, trace to little fine gravel, trace of very fine-grained sand.                             |                 |
|                  |         |         | Soft Plastic                | 3             | 65                | 13    | 7               | 7                      |   |                 |
|                  |         |         |                             |               |                   | 14    | 8               | 8                      |   |                 |
|                  |         |         |                             |               |                   | 15    |                 |                        |   |                 |
|                  |         |         |                             |               |                   | 16    |                 |                        |   |                 |
|                  |         |         |                             |               |                   | 17    |                 |                        |   |                 |
|                  |         |         |                             |               |                   | 18    |                 |                        |   |                 |
|                  |         |         |                             |               |                   | 19    |                 |                        |   |                 |
|                  |         |         |                             |               |                   | 20    |                 |                        |   |                 |

|             |  |           |  |        |  |             |
|-------------|--|-----------|--|--------|--|-------------|
| EXPLANATION |  | GROUT     |  | SAND   |  | SCREEN      |
|             |  | BENTONITE |  | CASING |  | WATER LEVEL |



V. well MPA MPA  
 0 0 0  
 R 10' x 10' x 10'

|                 |                                  |                 |                                    |
|-----------------|----------------------------------|-----------------|------------------------------------|
| WELL NUMBER     | FC-2 MPA                         | LOCATION        | ADJACENT TO MPA FIRE TRAINING AREA |
| DATE            | 12-9-92                          | WEATHER         | CLAR, Temp 40's                    |
| LOGGED BY       | J. Paulik                        | DRILLED BY      | James Ennie, D.R.L.C.              |
| DRILLING METHOD | 4.25" Hollow-Stem Lucas          | SAMPLING METHOD | 1.5' California Sampler            |
| GRAVEL PACK     | See well completion for FC-2 MPA | SEAL            |                                    |

|             |          |          |                 |
|-------------|----------|----------|-----------------|
| CASING TYPE | DIAMETER | LENGTH   | HOLE DIA. 8"    |
| SCREEN TYPE | SLOT     | DIAMETER | LENGTH          |
|             |          |          | TOTAL DEPTH 14' |

| MOISTURE CONTENT | SORTING | DENSITY | PLASTICITY  | SAMPLE NUMBER | TIP READING (PPM) | DEPTH | SAMPLE RECOVERY | PENETRATION RESISTANCE | LITHOLOGY/REMARKS  | WELL COMPLETION   |
|------------------|---------|---------|-------------|---------------|-------------------|-------|-----------------|------------------------|--|---|
|                  |         |         |             |               |                   | 0     |                 |                        | <p>Note: Samples were collected from selected intervals using a California sampler. All other lithology descriptions are from cuttings.</p> <p>0' - 3.5' - (cuttings) Clay, black, some fine and coarse limestone gravel, trace of silt.</p> <p>0.00' - 0.65' - Clay, black, same as above</p> <p>5.0' - 8.5' - (cuttings) - Clay, black, some fine and coarse gravel, trace to little silt.</p> <p>8.00' - 1.24' - Clay, black, some fine and coarse limestone gravel, trace of silt.</p> <p>11' - 12.5' - (cuttings) Clay, same as above</p> <p>0.00' - 0.45' - Clay, same as above.</p> <p>0.45' - 1.50' - Clay, dark gray, little to some silt, little fine limestone gravel</p> | <p>Vegetation about well station<br/>                     Same as MPA</p> |
| Moist            |         |         | Egt Plastic |               |                   | 1     |                 |                        |  |   |
| Moist            |         |         | Egt Plastic | 1             | 6                 | 4     | 5               |                        |  |   |
| Moist            |         |         | Egt Plastic |               |                   | 5     | 11              |                        |  |   |
| Moist            |         |         | Egt Plastic |               |                   | 6     |                 |                        |  |   |
| Moist            |         |         | Egt Plastic |               |                   | 7     |                 |                        |  |   |
| Moist            |         |         | Egt Plastic |               |                   | 8     |                 |                        |  |   |
| Moist            |         |         | Egt Plastic | 2             | 14                | 9     | 4               |                        |  |   |
| Moist            |         |         | Egt Plastic |               |                   | 10    | 4               |                        |  |   |
| Moist            |         |         | Egt Plastic |               |                   | 11    | 8               |                        |  |   |
| Moist            |         |         | Egt Plastic |               |                   | 12    |                 |                        |  |   |
| Moist            |         |         | Egt Plastic | 3             | 85                | 13    | 4               |                        |  |   |
| Moist            |         |         | Egt Plastic |               |                   | 14    | 4               |                        |  |   |
| Moist            |         |         | Egt Plastic |               |                   | 15    | 6               |                        |  |   |
|                  |         |         |             |               |                   | 16    |                 |                        |  |   |
|                  |         |         |             |               |                   | 17    |                 |                        |  |   |
|                  |         |         |             |               |                   | 18    |                 |                        |  |   |
|                  |         |         |             |               |                   | 19    |                 |                        |  |   |
|                  |         |         |             |               |                   | 20    |                 |                        |  |   |

|             |           |        |             |
|-------------|-----------|--------|-------------|
| EXPLANATION | GROUT     | SAND   | SCREEN      |
|             | BENTONITE | CASING | WATER LEVEL |

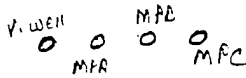

|                 |                                  |                 |                                    |
|-----------------|----------------------------------|-----------------|------------------------------------|
| WELL NUMBER     | FC-2 MPC                         | LOCATION        | ADJACENT TO MPC FIRE TRAINING AREA |
| DATE            | 12-9-92                          | WEATHER         | Clear, Temp. 70's                  |
| LOGGED BY       | J. Pawlik                        | DRILLED BY      | JONES FLOOR, DALS.                 |
| DRILLING METHOD | 4.75" Hollow-stem Augers         | SAMPLING METHOD | 2.0' Split-Spoon                   |
| GRAVEL PACK     | see well completion for FC-2 MPA | SEAL            |                                    |

| CASING           |         | TYPE              | DIAMETER                        |               | LENGTH            | HOLE DIA. |                 |                        |   |                                      |
|------------------|---------|-------------------|---------------------------------|---------------|-------------------|-----------|-----------------|------------------------|---|--------------------------------------|
| SCREEN           |         | TYPE              | SLOT                            |               | DIAMETER          | LENGTH    |                 |                        |   |                                      |
| MOISTURE CONTENT | SORTING | DENSITY           | PLASTICITY                      | SAMPLE NUMBER | TIP READING (PPM) | DEPTH     | SAMPLE RECOVERY | PENETRATION RESISTANCE | LITHOLOGY/REMARKS   | WELL COMPLETION                      |
|                  |         |                   |                                 |               |                   | 0         |                 |                        | <p>NOTE: Samples were collected every five feet using a 1.5' split-spoon. All other lithology descriptions are from cuttings.</p> <p>0'-3'-(cuttings) Clay, black and limestone gravel, fine and coarse.</p> <p>0.00'-0.66' - Clay, black and gravel, fine and coarse</p> <p>5'-8.5' (cuttings) Clay, black, little limestone gravel, fine, trace to little silt.</p> <p>0.00'-0.45' - Clay, dark gray to gray and gravel, fine and coarse, little silt</p> <p>10'-12.5' - Clay, same as above.</p> <p>0.00'-0.52' - Clay, black and gravel, fine and coarse, little silt</p> | Vapor panel installation same as MPA |
| Moist            |         | Soft to med stiff | Slightly plastic                |               |                   | 1         |                 |                        |   |                                      |
| Moist            |         | Soft              | Slightly plastic to med plastic | 1             | 13                | 2         | 5               |                        |   |                                      |
| Moist            |         | Soft              | Plastic                         |               |                   | 3         | 5               |                        |   |                                      |
| Moist            |         | Soft              | Plastic to med. plastic         | 2             | 39                | 4         | 3               |                        |   |                                      |
| Moist            |         | Soft              | Plastic to med-plastic          |               |                   | 5         | 4               |                        |   |                                      |
| Moist            |         | Soft              | Slightly plastic                | 3             | 99                | 6         | 5               |                        |   |                                      |
|                  |         |                   |                                 |               |                   | 7         |                 |                        |   |                                      |
|                  |         |                   |                                 |               |                   | 8         |                 |                        |   |                                      |
|                  |         |                   |                                 |               |                   | 9         |                 |                        |   |                                      |
|                  |         |                   |                                 |               |                   | 10        |                 |                        |   |                                      |
|                  |         |                   |                                 |               |                   | 11        |                 |                        |   |                                      |
|                  |         |                   |                                 |               |                   | 12        |                 |                        |   |                                      |
|                  |         |                   |                                 |               |                   | 13        | 7               |                        |   |                                      |
|                  |         |                   |                                 |               |                   | 14        | 8               |                        |   |                                      |
|                  |         |                   |                                 |               |                   | 15        |                 |                        |   |                                      |
|                  |         |                   |                                 |               |                   | 16        |                 |                        |   |                                      |
|                  |         |                   |                                 |               |                   | 17        |                 |                        |   |                                      |
|                  |         |                   |                                 |               |                   | 18        |                 |                        |   |                                      |
|                  |         |                   |                                 |               |                   | 19        |                 |                        |   |                                      |
|                  |         |                   |                                 |               |                   | 20        |                 |                        |   |                                      |

EXPLANATION

|  |           |  |        |  |             |
|--|-----------|--|--------|--|-------------|
|  | GROUT     |  | SAND   |  | SCREEN      |
|  | BENTONITE |  | CASING |  | WATER LEVEL |

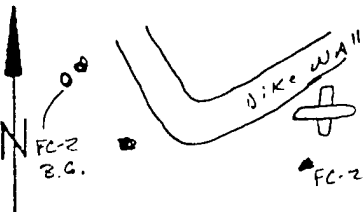

|                 |                                  |                 |                               |
|-----------------|----------------------------------|-----------------|-------------------------------|
| WELL NUMBER     | FC-2 BACKGROUND                  | LOCATION        | West of Fire Training Grounds |
| DATE            | 12-10-92                         | WEATHER         | Clear, Temp. 60's             |
| LOGGED BY       | J. Pawlik                        | DRILLED BY      | Jones Enwik. SPC.             |
| DRILLING METHOD | 4.75" Hollow-stem Augers         | SAMPLING METHOD | 1.5' Split-Spoon              |
| GRAVEL PACK     | see well completion for FC-2 MPA | SEAL            |                               |

|             |  |          |  |          |  |              |                 |
|-------------|--|----------|--|----------|--|--------------|-----------------|
| CASING TYPE |  | DIAMETER |  | LENGTH   |  | HOLE DIA. 8" |                 |
| SCREEN TYPE |  | SLOT     |  | DIAMETER |  | LENGTH       | TOTAL DEPTH 14' |

| MOISTURE CONTENT | SORTING | DENSITY | PLASTICITY                          | SAMPLE NUMBER | TIP READING (PPM) | DEPTH | SAMPLE RECOVERY | PENETRATION RESISTANCE | LITHOLOGY/REMARKS   | WELL COMPLETION |
|------------------|---------|---------|-------------------------------------|---------------|-------------------|-------|-----------------|------------------------|---|-----------------|
|                  |         |         |                                     |               |                   | 0     |                 |                        | <p>Note: Samples were collected every five feet using a 1.5' split-spoon. All other lithologic descriptions are from cuttings.</p> <p>0' - 3.5' (cuttings) Clay, dark brown, some silt and limestone rock.</p> <p>0.00' - 0.69' - Clay, dark brown and limestone gravel, fine.</p> <p>5' - 8.5' - (cuttings) Gravel to 6.5', 6.5' to 8.5' Clay, dark brown, some silt and fine gravel.</p> <p>0.00' - 0.62' - Gravel, limestone, fine and coarse, some clay, dark brown, little silt.</p> <p>10' - 12.5' (cuttings) gravel and clay, Clay begins at 11', Silty.</p> <p>0.00' - 1.62' - Clay, gray to dark gray, little silt, trace to little fine gravel.</p> |                 |
|                  |         |         |                                     |               |                   | 1     |                 |                        |   |                 |
| Moist            |         |         | Plastic to slightly plastic         |               |                   | 2     |                 |                        |   |                 |
|                  |         |         |                                     |               |                   | 3     |                 |                        |   |                 |
| Moist            |         |         | Slightly plastic to non-plastic     | 1             | 12                | 4     | 0.69            | 10                     |   |                 |
|                  |         |         |                                     |               |                   | 5     |                 | 9                      |   |                 |
|                  |         |         |                                     |               |                   | 6     |                 | 5                      |   |                 |
| Moist            |         |         | Stiff non-plastic to hard           |               |                   | 7     |                 |                        |   |                 |
|                  |         |         |                                     |               |                   | 8     |                 |                        |   |                 |
| Moist to clay    |         |         | Hard non-plastic                    | 2             | 16                | 9     | 0.62            | 36                     |   |                 |
|                  |         |         |                                     |               |                   | 10    |                 | 6                      |   |                 |
| Moist            |         |         | Hard to soft non-plastic to plastic |               |                   | 11    |                 |                        |   |                 |
|                  |         |         |                                     |               |                   | 12    |                 |                        |   |                 |
| Moist            |         |         | Slightly plastic to plastic         | 3             | 41                | 13    | 1.62            | 4                      |   |                 |
|                  |         |         |                                     |               |                   | 14    |                 | 5                      |   |                 |
|                  |         |         |                                     |               |                   | 15    |                 | 7                      |   |                 |
|                  |         |         |                                     |               |                   | 16    |                 |                        |   |                 |
|                  |         |         |                                     |               |                   | 17    |                 |                        |   |                 |
|                  |         |         |                                     |               |                   | 18    |                 |                        |   |                 |
|                  |         |         |                                     |               |                   | 19    |                 |                        |   |                 |
|                  |         |         |                                     |               |                   | 20    |                 |                        |   |                 |

Deeper gravel well installation same as MPA

EXPLANATION

|  |           |  |        |  |             |
|--|-----------|--|--------|--|-------------|
|  | GROUT     |  | SAND   |  | SCREEN      |
|  | BENTONITE |  | CASING |  | WATER LEVEL |







**AIR TOXICS LTD.**  
AN ENVIRONMENTAL ANALYTICAL LABORATORY

11325 SUNRISE GOLD CIRCLE, SUITE 'E'  
RANCHO CORDOVA, CA 95742  
(916) 638-9892 • FAX (916) 638-9917

## CHAIN OF CUSTODY RECORD

Page 1 of 1

PROJECT # DEZ68.19.09 PO # \_\_\_\_\_

REMARKS Please contact Gail Sexton or John Ritz if any questions, Engineering-Science, Inc. 1700 Broadway, Suite 900 Denver, CO 80290

COLLECTED BY (Signature) John Ritz

| FIELD SAMPLE I.D.# | SAMPLING MEDIA (Tenax, Canister etc.) | DATE/TIME     | ANALYSIS | VAC./PRESSURE | LAB I.D. # |
|--------------------|---------------------------------------|---------------|----------|---------------|------------|
| KY-FC-Z-VW         | Summa Canister                        | 12/12/92 145Z | T03      |               |            |
| KY-FC-Z-MPA-13.5   |                                       | 12/12/92 1536 |          |               |            |
| KY-FC-Z-MPC-13.5   |                                       | 12/12/92 1557 |          |               |            |
| KY-FC-Z-BG-13.5    |                                       | 12/13/92 1218 |          |               |            |
| KY-S-4-MPA-12.5    |                                       | 12/14/92 1443 |          |               |            |
| KY-S-4-MPC-12.5    |                                       | 12/14/92 1515 |          |               |            |
| KY-S-4-VW          |                                       | 12/14/92 1530 |          |               |            |
|                    |                                       |               |          |               |            |
|                    |                                       |               |          |               |            |
|                    |                                       |               |          |               |            |
|                    |                                       |               |          |               |            |

RELINQUISHED BY: DATE/TIME John Ritz 12/14/92 1700 RECEIVED BY: DATE/TIME \_\_\_\_\_  
FEDERAL EXPRESS

SHIPPER NAME \_\_\_\_\_ AIR BILL # \_\_\_\_\_ OPENED BY: DATE/TIME \_\_\_\_\_  
 TEMP(°C) \_\_\_\_\_

REMARKS \_\_\_\_\_

LAB USE ONLY

CONDITION

RECEIVED BY: DATE/TIME