

LOAN DOCUMENT

PHOTOGRAPH THIS SHEET

①

DTIC ACCESSION NUMBER

LEVEL

INVENTORY

Operation + Maintenance Manual for ...

DOCUMENT IDENTIFICATION

may 910

DISTRIBUTION STATEMENT A
Approved for Public Release
Distribution Unlimited

DISTRIBUTION STATEMENT

ACCESSION BY	
NTIS	GRAM <input checked="" type="checkbox"/>
DTIC	TRAC <input type="checkbox"/>
UNANNOUNCED JUSTIFICATION	
BY	
DISTRIBUTION/	
AVAILABILITY CODES	
DISTRIBUTION	AVAILABILITY AND/OR SPECIAL
A-1	

DISTRIBUTION STAMP

DATE ACCESSIONED

DATE RETURNED

20001121 046

DATE RECEIVED IN DTIC

REGISTERED OR CERTIFIED NUMBER

PHOTOGRAPH THIS SHEET AND RETURN TO DTIC-FDAC

H
A
N
D
L
E

W
I
T
H

C
A
R
E

**Operation and Maintenance Manual for
Bioventing Pilot Testing Systems
Spill Site No. 1, Building 457, and UST 702**



**Eaker Air Force Base
Blytheville, Arkansas**

Prepared For

**Air Force Center for Environmental Excellence
Brooks Air Force Base, Texas**

and

**Air Force Base Conversion Agency/OL-J
Eaker Air Force Base, Arkansas**

May 1996

 **PARSONS
ENGINEERING SCIENCE, INC.**

1700 Broadway, Suite 900 • Denver, Colorado 80290

AQ MOI-02-0284

DEFENSE TECHNICAL INFORMATION CENTER REQUEST FOR SCIENTIFIC AND TECHNICAL REPORTS

Title AFCEE Collection

1. Report Availability (Please check one box)	2a. Number of Copies Forwarded	2b. Forwarding Date

each July/2000

2c. Distribution Statement (Please check ONE box)

DoD Directive 5230.24, "Distribution Statements on Technical Documents," 18 Mar 87, contains seven distribution statements, as described briefly below. Technical documents MUST be assigned a distribution statement.

- DISTRIBUTION STATEMENT A: Approved for public release. Distribution is unlimited.
- DISTRIBUTION STATEMENT B: Distribution authorized to U.S. Government Agencies only.
- DISTRIBUTION STATEMENT C: Distribution authorized to U.S. Government Agencies and their contractors.
- DISTRIBUTION STATEMENT D: Distribution authorized to U.S. Department of Defense (DoD) and U.S DoD contractors only.
- DISTRIBUTION STATEMENT E: Distribution authorized to U.S. Department of Defense (DoD) components only.
- DISTRIBUTION STATEMENT F: Further dissemination only as directed by the controlling DoD office indicated below or by higher authority.
- DISTRIBUTION STATEMENT X: Distribution authorized to U.S. Government agencies and private individuals or enterprises eligible to obtain export-controlled technical data in accordance with DoD Directive 5230.25, Withholding of Unclassified Technical Data from Public Disclosure, 6 Nov 84.

2d. Reason For the Above Distribution Statement (in accordance with DoD Directive 5230.24)

2e. Controlling Office <u>HQ AFCEE</u>	2f. Date of Distribution Statement Determination <u>15 Nov 2000</u>
---	--

3. This report is NOT forwarded for the following reasons. (Please check appropriate box)

- It was previously forwarded to DTIC on (date) and the AD number is
- It will be published at a later date. Enter approximate date if known.
- In accordance with the provisions of DoD Directive 3200.12, the requested document is not supplied because:
.....
.....

Print or Type Name <u>Laura Peña</u>	Signature <u>Laura Peña</u>
Telephone <u>210-536-1431</u>	(For DTIC Use Only) AQ Number <u>MD-02-0284</u>

CONTENTS

	<u>Page</u>
SECTION 1 - INTRODUCTION	1-1
SECTION 2 - SYSTEM DESCRIPTION	2-1
2.1 Blower Systems	2-1
2.2 Monitoring and Flow Control Equipment	2-1
2.2.1 Monitoring Gauges	2-1
2.2.2 Flow Control Equipment	2-1
SECTION 3 - SYSTEM MAINTENANCE	3-1
3.1 Blowers/Motors	3-1
3.2 Air Filters	3-1
3.3 Maintenance Schedule	3-2
3.4 Major Repairs	3-2
SECTION 4 - SYSTEM MONITORING	4-1
4.1 Blower Performance Monitoring	4-1
4.2 Monitoring Schedule	4-1
4.3 Reporting Monitoring Results	4-1
APPENDIX A As-Built Blower System Instrumentation Diagrams	
APPENDIX B Regenerative Blower Information	
APPENDIX C Data Collection Sheets	

SECTION 1

INTRODUCTION

This Operations and Maintenance (O&M) Manual has been created as a guide for monitoring and maintaining the performance of the pilot-scale bioventing blower systems and vent well plumbing at Spill Site No. 1, Building 457, and underground storage tank (UST) 702, at Eaker Air Force Base (AFB), Arkansas.

Bioventing is the forced injection of fresh air, or withdrawal of soil gas, to enhance the supply of oxygen in subsurface soils for *in situ* bioremediation. A blower system is used to inject air into the soil, thereby supplying fresh atmospheric air (with approximately 20.8 percent oxygen) to contaminated soils. Once oxygen is provided to the subsurface, existing soil bacteria aerobically break down fuel residuals. Aerobic biodegradation is much more efficient than anaerobic biodegradation which occurs in oxygen depleted soils.

Parsons Engineering Science, Inc. (Parsons ES) has installed three air injection bioventing systems at Eaker AFB. The system at Spill Site No. 1 consists of an air injection blower, blower shed, six vent wells (VWs), five soil gas monitoring points (MPs), and associated piping at the site. The blower systems at Building 457 and UST 702 are similar to the Spill Site No. 1 system, but treat a smaller volume of contaminated soils. The system at Building 457 has two VWs and the system at UST 702 has one VW. Both of these smaller systems have three MPs. The blowers at these three sites were started in early April 1996 and the injection rates were optimized at each vent well to assure adequate aeration of contaminated soils to promote aerobic biodegradation.

Air Force Base Conversion Agency (AFBCA) personnel located at Eaker AFB are responsible for routine monitoring of the bioventing systems. If significant problems are encountered with the operation of these systems, Parsons ES should be notified so repairs can be made. Under the Extended Bioventing Project Option 1, Parsons ES is responsible for system repair for a 1-year period after system startup (i.e., until April 1997). Should the bioventing systems cease to operate or develop significant problems, please call the Parsons ES Site Manager, Mr. Dave Teets, at (303) 831-8100.

SECTION 2

SYSTEM DESCRIPTION

2.1 BLOWER SYSTEMS

Gast® regenerative blowers were installed at each of the three sites. A Gast® R5 blower powered by a 2-horsepower direct-drive motor was installed at Spill Site No. 1. Gast® R4P blowers with 1-horsepower direct-drive motors were installed at Building 457 and UST 702. The R5 blower is rated as having a flow rate of 110 standard cubic feet per minute (scfm) at a pressure of 40 inches of water, and the R4P blowers are rated as having a flow rate of 90 scfm at 30 inches of water. The actual performance of these blowers will vary with changing site conditions. As installed, the blower at Spill Site No. 1 was producing an estimated average flow rate of 26 actual cubic feet per minute (acfm) into each of six injection VWs at a pressure of 30.5 inches of water. The blower at Building 457 was producing an estimated flow rate of 15 acfm into each of two injection VWs at a pressure of 20 inches of water. The blower at UST 702 was producing an estimated flow rate 50 acfm into one VW at 30 inches of water. The blower systems at all three sites include an inlet air filter to remove any particulates which are entrained in the inlet air stream and several valves and monitoring gauges which are described in Section 2.2. Schematics of the pilot-scale blower systems installed at the three sites are provided in Appendix A. Corresponding blower performance curves and relevant service information are provided in Appendix B.

2.2 MONITORING AND FLOW CONTROL EQUIPMENT

2.2.1 Monitoring Gauges

The bioventing systems are equipped with vacuum, pressure, and temperature gauges, and air velocity measurement ports. Gauges have been installed on the air injection systems at the following locations: a vacuum gauge in the inlet piping and pressure and temperature gauges in the outlet piping.

2.2.2 Flow Control Equipment

Manual and automatic pressure relief valves (PRVs) and flow control valves (FCVs) have been installed on all three bioventing blower systems. Manual PRVs, or bleed valves, have been installed in the outlet piping, immediately following the blower. The bleed valves control the total system pressure and air flow out of the blower by releasing excess air flow to the atmosphere. Automatic PRVs installed immediately following the manual PRVs are used to protect the blower systems from burning out if pressures rise due to pipe blockage. The automatic PRV is set to bleed off flow at a preset pressure and thus prevent blower outlet pressure from ever exceeding the rated pressure. Manual FCVs have been installed in the

pipng leading to each VW to enable the flow rate to each VW to be adjusted individually. The FCVs and bleed valves have been set by Parsons ES personnel to deliver a calculated amount of air to each VW and should not be adjusted unless directed to do so by Parsons ES personnel.

The blower systems have also been equipped with flow measurement ports. These ports consist of brass bushings installed in the outlet piping leading to each VW. These bushings, which should be plugged during system operation, allow the insertion of a thermal anemometer for the measurement of air velocity. These ports are used by Parsons ES personnel to measure and control the flow of air into each individual vent well.

SECTION 3

SYSTEM MAINTENANCE

Although the blower systems installed at Spill Site No. 1, Building 457, and UST 702 are relatively maintenance free, periodic system maintenance is required for proper operation and long life. Recommended maintenance procedures and schedule are described in detail in the instruction manuals included in Appendix B and briefly summarized in this section.

Filter inspection must be performed with the systems turned off. Do not change the flow control valve settings (valves have been pre-set for a specific flow rate) before re-starting the blower.

3.1 BLOWERS/MOTORS

The blower and motor for each blower system are relatively maintenance free and should not require any maintenance during the operational period. For each system, both the blower and motor have sealed bearings and do not require lubrication.

3.2 AIR FILTERS

To avoid damage caused by passing solids through the blowers, air filters have been installed in-line before each blower. The paper filter elements contained within the filter assemblies are accompanied by polyurethane foam prefilters. The filters should be checked weekly for the first 2 months of operation. A facility employee should determine the best schedule for filter replacement based on the first 2 months of system monitoring. The polyurethane prefilters can be washed with lukewarm water and a mild detergent. Paper filter elements should never be washed, and should be disposed of and replaced as necessary. When the pressure or vacuum drop across the filter is 15 inches of water or greater, a dirty filter element should be suspected, and cleaning or replacement should be performed. Typical filter element replacement intervals range from 3 to 6 months.

To remove a filter, turn the system off by pushing the stop button on the starter, loosen the three clamps or the wing nut on the filter top, lift the metal top off the air filter, and lift the air filter element from the metal housing. Remove the polyurethane prefilter (if applicable) and wash before replacing.

The filter element is manufactured by Solberg Manufacturing, Inc. in Itasca, Illinois. Their telephone number is (708) 773-1363. Additional filters can also be obtained through Parsons ES. The Parsons ES contacts are Mr. Dave Teets and Mr. Craig Snyder at (303) 831-8100. The part number for the replacement filter element is 30P. Spare air filter elements have been placed inside the blower enclosures.

3.3 MAINTENANCE SCHEDULE

The following maintenance schedule is recommended for each blower system. During the initial few months of operation more frequent monitoring is recommended to ensure that any startup problems are quickly corrected. A daily drive-by inspection is recommended during the initial 2 weeks of operation to ensure that the blower system are still operating with no unusual sounds. Thereafter monitoring inspections every 2 weeks are recommended (see Section 4). Preprinted data collection sheets for recording maintenance activities are provided in Appendix C.

<u>Maintenance Item</u>	<u>Maintenance Frequency</u>
Filter	Check once every 2 weeks, wash or replace as necessary (see Section 3.3). Inlet vacuum exceeding 15 inches of water indicates that the filter requires cleaning or replacement.

3.4 MAJOR REPAIRS

Blower systems are very reliable when properly maintained. Occasionally, however, a motor or blower will develop a serious problem. If a blower system fails to start, and a qualified electrician verifies that power is available at the blower or starter, Parsons ES should be contacted to arrange for repairs. The Parsons ES contacts are Mr. Dave Teets and Mr. Craig Snyder at (303) 831-8100. Parsons ES is responsible for major repairs during the first year of operation.

SECTION 4

SYSTEM MONITORING

4.1 BLOWER PERFORMANCE MONITORING

To monitor blower performance, the vacuum, pressure, and temperature should be measured for each blower system. All vacuum and pressure readings can be read directly from the gauges (in inches of water) and temperature measured and recorded in degrees Fahrenheit (°F). These data should be recorded every 2 weeks on a data collection sheet (provided in Appendix C). In addition, the power usage for each system should be measured in accordance with Base requirements. All measurements should be taken at the same time while the systems are running. Because the systems are noisy, hearing protection should be worn at all times when working near the operating blowers.

4.2 MONITORING SCHEDULE

The following monitoring schedule is recommended for these systems. During the initial month of operation, more frequent monitoring is recommended to ensure that any start up problems are quickly corrected. Data collection sheets have been provided to assist your data collection and are included in Appendix C.

<u>Monitoring Item</u>	<u>Monitoring Frequency</u>
Vacuum/Pressure	Daily during first week, then once every 2 weeks.
Temperature	Daily during first week, then once every 2 weeks.
Power Usage	As required.

4.3 REPORTING MONITORING RESULTS

System monitoring data sheets should be faxed to the Parsons ES Site Manager, Mr. Dave Teets at (303) 831-8100, once every 2 months. However, if a significant change in the system temperature or pressure is noted (such as a significant drop or increase in pressure) please call Mr. Teets immediately. A significant change in system temperature or pressure may be indicative of a problem with the air delivery system or blower.

APPENDIX A
AS-BUILT
BLOWER SYSTEM INSTRUMENTATION DIAGRAMS

LEGEND

- ① INLET AIR FILTER - SOLBERG F-30P-150
- ② VACUUM GAUGE (IN H₂O)
- ③ BLOWER - GAST[®] 2.5HP R5125Q-50
- ④ MANUAL PRESSURE RELIEF (BLEED) VALVE 1 1/2" GATE
- ⑤ AUTOMATIC PRESSURE RELIEF VALVE
- ⑥ TEMPERATURE GAUGE - (°F)
- ⑦ PRESSURE GAUGE - (IN H₂O)
- ⑧ FLOW CONTROL VALVE - 1 1/2" GATE
- ⑨ FLOW MEASURING PORT FITTED WITH PLUG
- ⑩ STARTER
- ⑪ BREAKER BOX - 240V/SINGLE PHASE/40 AMP

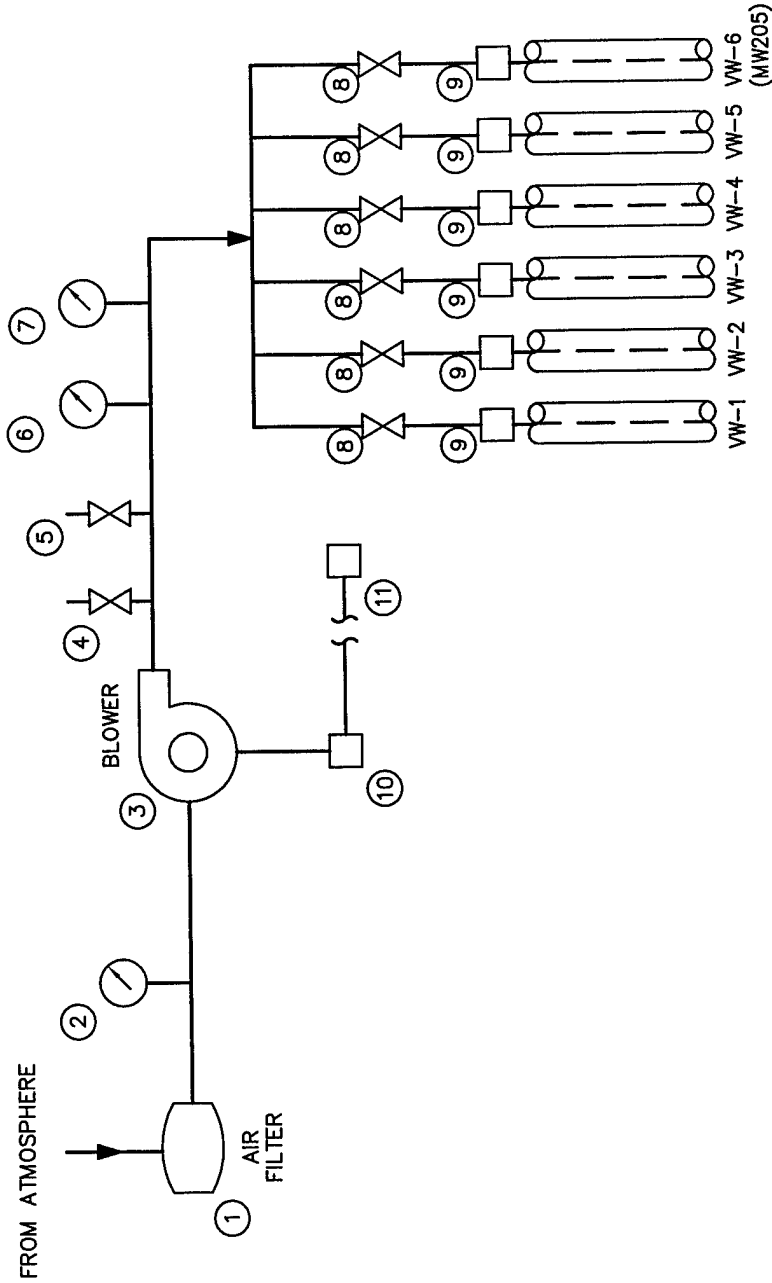

NO SCALE

FIGURE A.1
AS-BUILT BLOWER SYSTEM
INSTRUMENTATION
DIAGRAM FOR AIR INJECTION
SPILL SITE NO. 1

Eaker AFB, Arkansas

PARSONS
ENGINEERING SCIENCE, INC.

Denver, Colorado

LEGEND

- ① INLET AIR FILTER - SOLBERG F-30P-150
- ② VACUUM GAUGE (IN H₂O)
- ③ BLOWER - GAST® 1.0HP R4310P-50
- ④ MANUAL PRESSURE RELIEF (BLEED) VALVE
1 1/2" GATE
- ⑤ AUTOMATIC PRESSURE RELIEF VALVE
- ⑥ TEMPERATURE GAUGE - (°F)
- ⑦ PRESSURE GAUGE - (IN H₂O)
- ⑧ FLOW MEASURING PORT FITTED WITH PLUG
- ⑨ FLOW CONTROL VALVE - 1 1/2" GATE
- ⑩ STARTER
- ⑪ BREAKER BOX - 230V/THREE PHASE/40 AMP

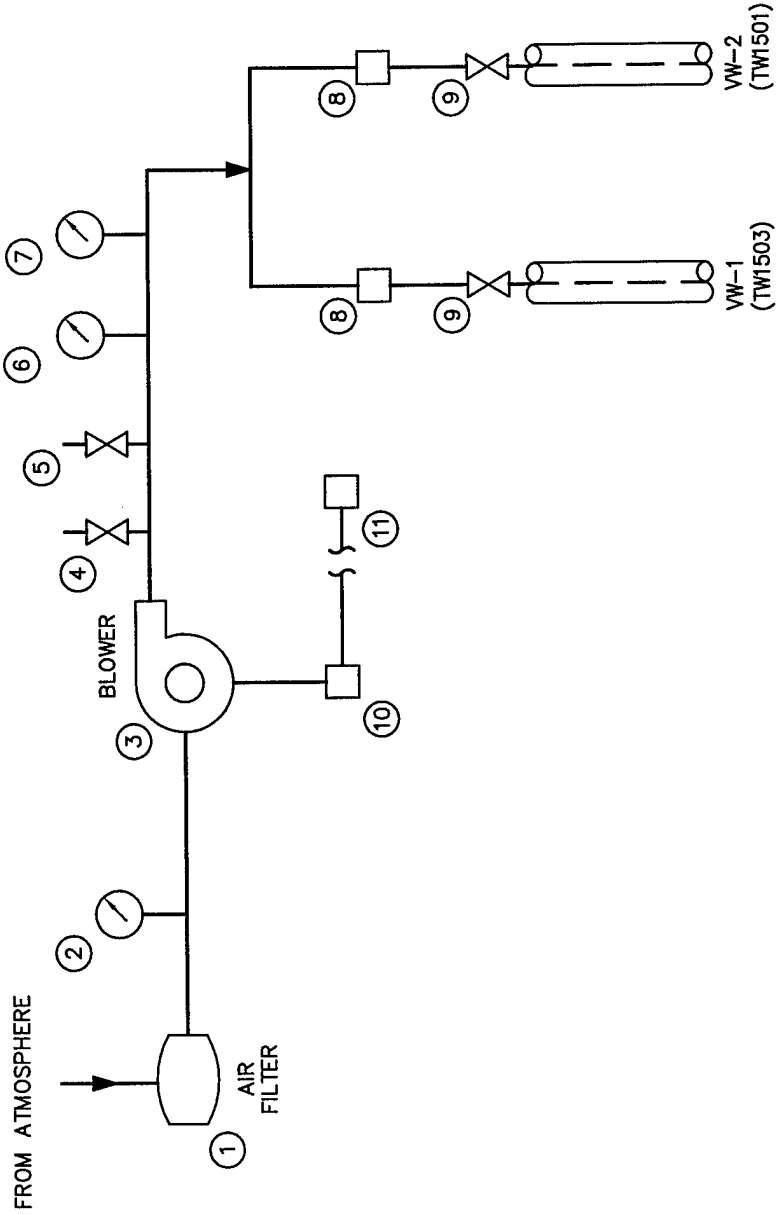

NO SCALE

FIGURE A.2
AS-BUILT BLOWER SYSTEM
INSTRUMENTATION
DIAGRAM FOR AIR INJECTION
BUILDING 457 AREA

Eaker AFB, Arkansas

PARSONS
ENGINEERING SCIENCE, INC.

Denver, Colorado

APPENDIX B
REGENERATIVE BLOWER INFORMATION

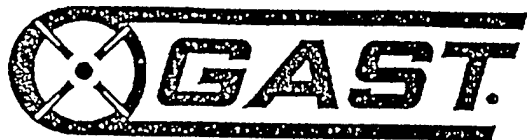

Post Office Box 97
Benton Harbor, Michigan 49023-0097
Ph: 616/926-6171
Fax: 616/925-8288

Maintenance Instructions for Gast Standard Regenerative Blowers

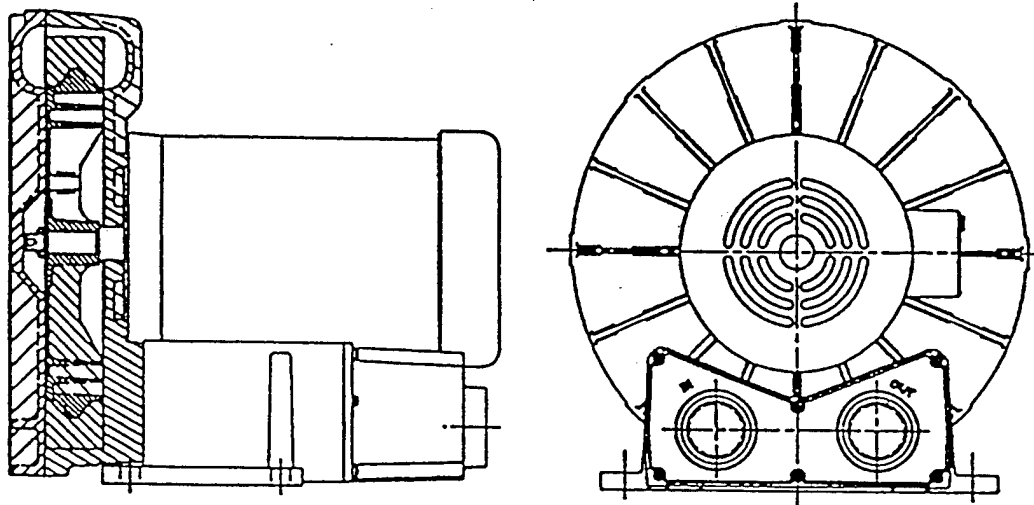

For original equipment manufacturers
special models, consult your local distributor

Gast Rebuilding Centers

Gast Mfg. Corp.
2550 Meadowbrook Rd.
Benton Harbor MI. 49022
Ph: 616/926-6171
Fax: 616/925-8288

Gast Mfg Corp.
505 Washington Avenue
Carlstadt, N. J. 07072
Ph: 201/933-8484
Fax: 201/933-5545

Brenner Fiedler. & Assoc.
13824 Bentley Place
Cerritos, CA. 90701
Ph: 213/404-2721
Fax: 213/404-7975

Wainbee, Limited
121 City View Drive
Toronto, Ont. Canada M9W 5A9
Ph: 416/243-1900
Fax: 416/243-2336

Wainbee, Limited
215 Brunswick Drive
Pointe Claire, P.Q. Canada H9R 4R7
Ph: 514/697-8810
Fax: 514/697-3070

Gast Mfg. Co. Limited.
Halifax Rd, Cressex Estate
High Wycombe, Bucks HP12 3SN
Ph. 44 494 523571
Fax: 44 494 436588

Japan Machinery Co. Ltd.
Central PO Box 1451
Tokyo 100-91 Japan
Ph: 813/3573-5421
Fax: 813/3571-7865

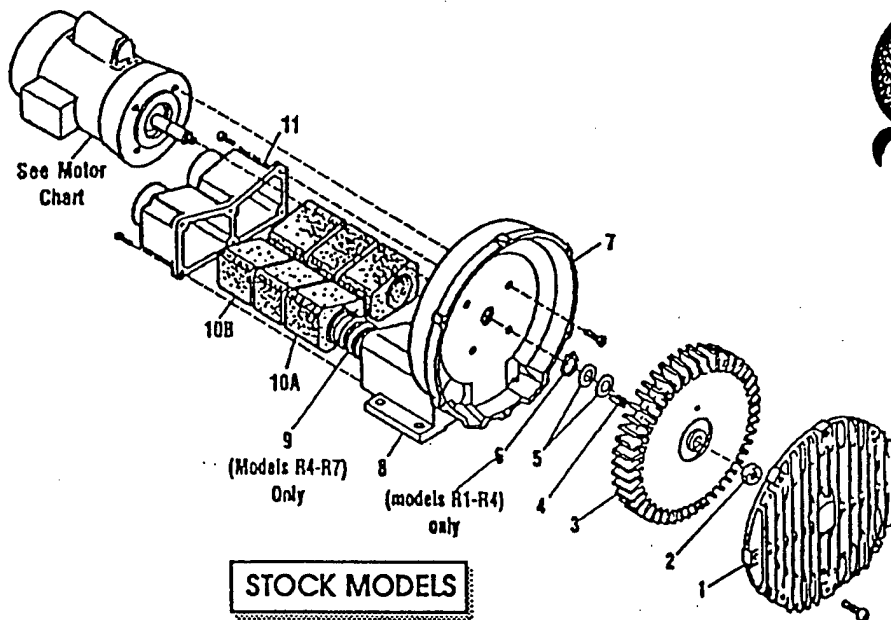

STOCK MODELS

Part Name	R1	R2	R3	R4	R5	R6	R6P	R6PP/R6PS	R7
#1 Cover	AJ101A	AJ101B	AJ101C	AJ101D	AJ101EQ	AJ101F	AJ101K	(2)AJ101KA	AJ101G
#2 Stopnut	BC187	BC187	BC181	BC181	BC181	BC181	BC181	(2)BC182	BC183
#3 Impeller	AJ102A	AJ102BQ	AJ102C	AJ102D	AJ102E	AJ102FR	AJ102K	(2)AJ102KA	AJ102GA
#4 Square Key	AH212C	AH212	AB136A	AB136D	AB136	AB136	AB136	(2)AB136	AC628
#5 Shim Spacer (s)	AJ132	AE686-3	AJ109	AJ109	AJ109	AJ116A	AJ116A	AJ116A	AJ110
#6 Retaining Ring	AJ145	AJ145	AJ149	AJ149					
#7 Housing	AJ103A	AJ103BQ	AJ103C	AJ103DR	AJ103E	AJ103F	AJ103K	AJ103KD	AJ103GA
#8 Muffler Box					AJ104E	AJ104F			
#9 Spring				AJ113DR	AJ113DQ	AJ113FQ	AJ113FQ		AJ113G
#10A Foam	(4)AJ112A	(4)AJ112B	(4)AJ112C	(4)AJ112DS	(4)AJ112ER	(6)AJ112F	(8)AJ112K		(8)AJ112GA
#10B Foam		(2)AJ112BQ	(2)AJ112CQ	(2)AJ112DR	(2)AJ112EQ				
#11 Muffler Extension/ Adapter Plate	AJ106H	AJ106BQ	AJ106CQ	AJ106DQ	AJ106EQ	AJ106EQ	AJ104K		AJ104GA
Shlm Kit	K396	K396							K395

MOTOR CHART

REGENAIR MODEL NUMBER	MOTOR NUMBER	MOTOR SPECIFICATIONS		PHASE
		60 HZ VOLTS	50 HZ VOLTS	
R1102	J111X	115/208-230	110/220-240	1
R1102C	J112X	115		1
R2103	J311X	115/208-230	110/220	1
R2105	J411X	115/208-230	110/220	1
R2303A	J310	208-230/460	220/380-415	3
R2303F	J313	208-230	220	3
R3105-1/R3105-12	J411X	115/208-230	110/220-240	1
R3305A-1/R3305A-13	J410	208-230/460	220/380-415	3
R4110-2	J611AX	115/208-230	110/220-240	1
R4310A-2	J610	208-230/460	220/380-415	3
R5125-2	J811X	115/208-230		1
R5325A-2	J810X	208-230/460	220/380-415	3
R6125-2	J811X	115/208-230		1
R6325A-2	J810X	208-230/460	220/380-415	3
R6335A-2	J910X	208-230/460	220/380-415	3
R6150J-2	J1013	230		1
R6350A-2	J1010	208-230/460	220/380-415	3
R6P335A	J910X	208-230/460	220/380-415	3
R6P350A	J1010	208-230/460	220/380-415	3
R6P355A	J1110A	208-230/460	220/380-415	3
R7100A-2*	J1210B	208-230/460	220/380-415	3
R6PP/R6PS3110M	JD1100	208-230/460	220/380-415	3

* No lubrication needed at start up. Bearings lubricated at factory.

* Motor is equipped with alermitte fitting. Clean tip of fitting and apply grease gun. Use 1 to 2 strokes of high quality ball bearing grease.

Consistency	Type	Typical Grease
Medium	Lithium	Shell Doltum R

Hours of service per year	Suggested Reube Interval
5,000	3 years
Continual Normal Application	1 year
Seasonal service motor idle for 6 months or more	1 year beginning of season 6 months

Continuous-high ambients, dirty or moist applications.



70-6100
F2-205/8/92
Rev. E

Post Office Box 97
Benton Harbor, MI. 49023-0097
Ph: 616/926-6171
Fax: 616/925-8288

INSTALLATION AND OPERATING INSTRUCTIONS FOR GAST HAZARDOUS DUTY REGENAIR BLOWERS

This instruction applies to the following models ONLY: R3105N-50, R4110N-50, R4310P-50, R4P115N-50, R5125Q-50, R5325R-50, R6130Q-50, R6P155Q-50, R6350R-50, R6P355R-50 and R7100R-50.

Gast Authorized Service Facilities are Located in the locations listed below

Gast Manufacturing Corporation
505 Washington Avenue
Carlstadt, N. J. 07072
Ph: 201/933-8484
Fax: 201/933-5545

Gast Manufacturing Corporation
2550 Meadowbrook Road
Benton Harbor, MI. 49022
Ph: 616/926-6171
Fax: 616/925-8288

Brenner Fiedler & Associates Wainbee Limited
13824 Bentley Place
Cerritos, CA. 90701
Ph: 310/404-2721
Ph: 800/843-5558
Fax: 310/404-7975

215 Brunswick Blvd.
Pointe Claire, Quebec
Canada H9R 4R7
Ph: 514/697-8810
Fax: 514/-697-3070

Wainbee Limited
5789 Coopers Ave.
Mississauga, Ontario
Canada L4Z 3S6
Ph: 416/243-1900
Fax: 416/243-2336

Japan Machinery
Central PO Box 1451
Toyko 100-91, Japan
Ph: 813 3573-5421
Fax: 813 3571-7896

Gast Manufacturing Co. Ltd.
Halifax Road, Cressex Estate
High Wycombe, Bucks HP12 3SN
England
Ph: 44 494 523571
Fax: 44 494 436588

OPERATING AND MAINTENANCE INSTRUCTIONS

SAFETY

This is the safety alert symbol. When you see this symbol personal injury is possible. The degree of injury is shown by the following signal words:

- ⚠ DANGER** Severe injury or death will occur if hazard is ignored.
- ⚠ WARNING** Severe injury or death can occur if hazard is ignored.
- ⚠ CAUTION** Minor injury or property damage can occur if hazard is ignored.

Review the following information carefully before operating.

GENERAL INFORMATION

This instruction applies to the following models ONLY: R3105N-50, R4110N-50, R4310P-50, R4P115N-50, R5125Q-50, R5325R-50, R6130Q-50, R6P155Q-50, R6350R-50, R6P355R-50 and R7100R-50. These blowers are intended for use in Soil Vapor Extraction Systems. The blowers are sealed at the factory for very low leakage. They are powered with a U.L. listed electric motor Class 1 Div. 1 Group D motors for Hazardous Duty locations. Ambient temperature for normal full load operation should not exceed 40° C (105° F). For higher ambient operation, contact the factory.

Gast Manufacturing Corporation may offer general application guidance: however, suitability of the particular blower and/or accessories is ultimately the responsibility of the user, not the manufacturer of the blower.

INSTALLATION

⚠ DANGER Models R5325R-50, R6130Q-50, R6350R-50, R5125Q-50, R6P155Q-50, R6P355R-50 AND R7100R-50 use Pilot Duty Thermal Overload Protection. Connecting this protection to the proper control circuitry is mandated by UL674 and NEC501. Failure to do so could/ may result in a EXPLOSION. See pages 3 and 4 for recommended wiring schematic for these models.

⚠ WARNING Electric shock can result from bad wiring. A qualified person must install all wiring, conforming to all required safety codes. Grounding is necessary.

⚠ WARNING This blower is intended for use on soil vapor extraction equipment. Any other use must be approved in writing by Gast Manufacturing, Corp. Install this blower in any mounting position. Do not block the flow of cooling air over the blower and motor.

PLUMBING - Use the threaded pipe ports for connection only. They will not support the plumbing. Be sure to use the same or larger size pipe to prevent air flow restriction and overheating of the blower. When installing fittings, be sure to use pipe thread sealant. This protects the threads in the blower housing and prevents leakage. Dirt and chips are often found in new plumbing. Do not allow them to enter the blower.

NOISE - Mount the unit on a solid surface that will not increase the sound. This will reduce noise and vibration. We suggest the use of shock mounts or vibration isolation material for mounting.

ROTATION - The Gast Regenair Blower should only rotate clockwise as viewed from the electric motor side. The casting has an arrow showing the correct direction. Confirm the proper rotation by checking air flow at the IN and OUT ports. If needed reverse rotation of three phase motors by changing the position of any two of the power line wires.

OPERATION

⚠ WARNING Solid or liquid material exiting the blower or piping can cause eye damage or skin cuts. Keep away from air stream.

⚠ WARNING - Gast Manufacturing Corporation will not knowingly specify, design or build any blower for installation in a hazardous, combustible or explosive location without a motor conforming to the proper NEMA or U. L. standards. Blowers with standard TEFC motors should never be utilized for soil vapor extraction applications or where local state and /or Federal codes specify the use of explosion-proof motors (as defined by the National Electric Code, Articles 100,500 c1990).

⚠ CAUTION Attach blower to solid surface before starting to prevent injury or damage from unit movement. Air containing solid particles or liquid must pass through a filter before entering the blower. Blowers must have filters, other accessories and all piping attached before starting. Any foreign material passing through the blower may cause internal damage to the blower.

⚠ CAUTION Outlet piping can burn skin. Guard or limit access. Mark "CAUTION Hot Surface. Can Cause Burns". Air temperature increases when passing through the blower. When run at duties above 50 in. H₂O, metal pipe may be required for hot exhaust air. The blower must not be operated above the limits for continuous duty. Only models R3105N-50, R4110N-50 and R4310P-50 can be operated continuously with no air flowing through the blower. Other units can only be run at the rating shown on the model number label. Do not Close off inlet (for vacuum) to reduce extra air flow. This will cause added heat and motor load. Blower exhaust air in excess of 230°F indicates operation in excess of rating which can cause the blower to fail.

ACCESSORIES ...Gast pressure gauge AJ496 and vacuum gauges AJ497 or AE134 show blower duty. The Gas pressure/vacuum relief valve, AG258, will limit the operating duty by admitting or relieving air. It also allows full flow through the blower when the relief valve closes.

SERVICING

⚠ WARNING To retain their sealed construction they should be serviced by Gast authorized service centers ONLY. These models are sealed at the factory for very low leakage.

⚠ WARNING Turn off electric power before removing blower from service. Be sure rotating parts have stopped. Electric shock or severe cuts can result. Inlet and exhaust filters attached to the blower may need cleaning or replacement of the elements. Failure to do so will result in more pressure drop, reduced air flow and hotter opera-

tion of the blower. The outside of the unit requires cleaning of dust and dirt. The inside of the blower also may need cleaning to remove foreign material coating the impeller and housing. This should be done at a Gast Authorized Service Center. This buildup can cause vibration, failure of the motor to operate or reduced flow.

KEEP THIS INFORMATION WITH THIS BLOWER. REFER TO IT FOR SAFE INSTALLATION, OPERATION OR SERVICE.

MOTOR WIRING DIAGRAM FOR R4110N-50 & R3105N-50

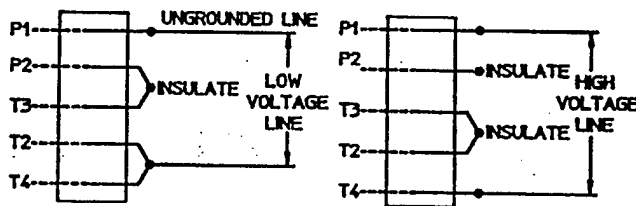

>>⚠ WARNING
THIS MOTOR IS THERMALLY PROTECTED AND WILL AUTOMATICALLY RESTART WHEN PROTECTOR RESETS. ALWAYS DISCONNECT POWER SUPPLY BEFORE SERVICING.

MOTORS WIRING DIAGRAM FOR R4310P-50

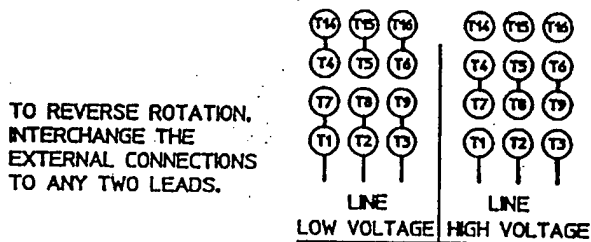

>>⚠ WARNING
THIS MOTOR IS THERMALLY PROTECTED AND WILL AUTOMATICALLY RESTART WHEN PROTECTOR RESETS. ALWAYS DISCONNECT POWER SUPPLY BEFORE SERVICING.

MOTORS WIRING DIAGRAM FOR R5325R-50, R6350R-50, R6P355R-50, & R7100R-50

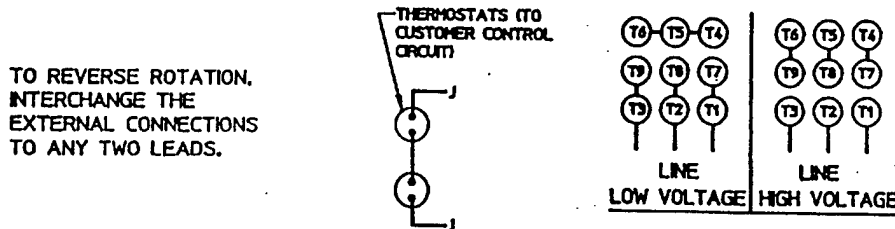

MOTOR WIRING DIAGRAM FOR R5125Q-50 & R4P115N-50

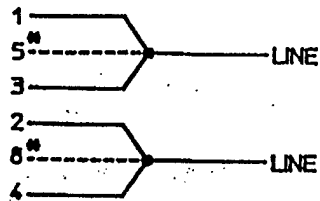

LOW VOLTAGE

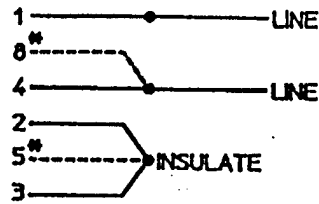

HIGH VOLTAGE

* R5125Q-50 BLOWERS PRODUCED AFTER SEPTEMBER 1992 (SER. NO. 0992) DO NOT HAVE MOTOR LEADS 5 & 8.

MOTOR WIRING DIAGRAM FOR R6130Q-50 & R6P155Q-50

CONNECT THERMOSTAT TO MOTOR PROTECTION CIRCUIT

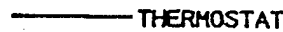
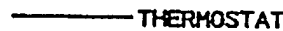

CONNECTION FOR THERMOSTAT MOTOR PROTECTION

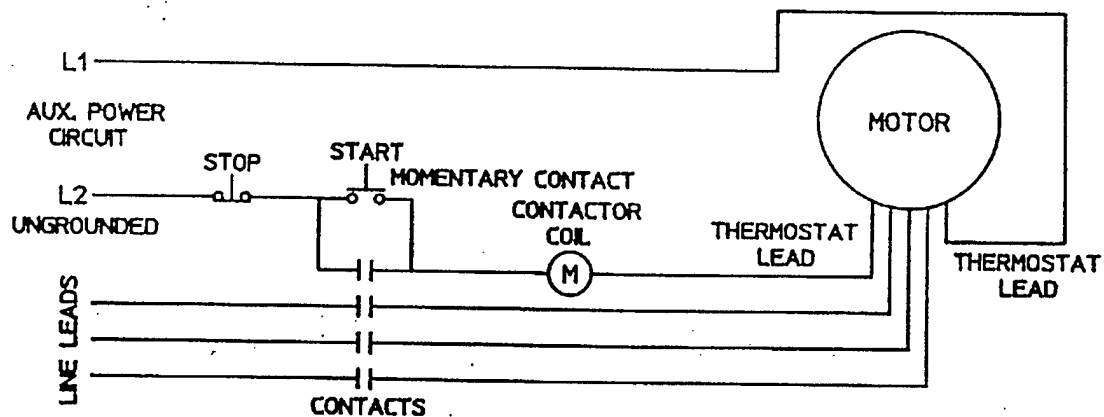

THERMOSTATS TO BE CONNECTED IN SERIES WITH CONTROL AS SHOWN. MOTOR FURNISHED WITH AUTOMATIC THERMOSTATS RATED A.C. 115-600V. 720VA

AK811 rev. E

SOIL VAPOR EXTRACTION PUMPS - REGENERATIVE BLOWERS

Product Specifications

Model Number	Phase	Hz	Motor Specifications			Max Vac		Max Pressure		Max Flow		Net. Wt.	
			Voltagess	HP	Full Load Amps	"H ₂ O mbar	"H ₂ O mbar	cfm m ³ /h	lbs kg				
R3105N-50	Single	50	110/220-240	.33	3-8/1.9-2.0	28	70	31	77	43	73	52	24
		60	115/208-230	0.5	5.2/2.9-2.6	40	100	43	107	53	90		
R4110N-50	Single	50	110/220-240	0.6	9.2/5.2-4.6	35	87	38	95	74	126	60	28
		60	115/208-230	1.0	11.4/6.2-5.6	48	120	51	127	92	156		
R4310P-50	Three	50	220/380	0.6	3.2/1.6	35	87	38	95	74	126	58	27
		60	208-230/460	1.0	3.4-3.3/1.65	48	120	51	127	92	156		
R4P115N-50	Single	50	110/220-240	1.0	15.2/7.6-8	40	100	45	112	112	190	79	36
		60	115/208-230	1.5	18.2/9.7-9.1	60	149	65	162	133	226		
R5125Q-50	Single	60	115/230	2.0	25/12.5	60	149	55	137	160	272	77	35
R5325R-50	Three	50	190-220/380-415	1.5	5.0-4.4/2.5-2.6	47	117	50	125	133	226	75	34
		60	208-230/460	2.0	6.0-5.6/2.8	60	149	65	162	160	272		
R6130Q-50	Single	50	220-240	2.5	14.7-13.5	65	162	75	187	182	309	129	59
		60	230	3.0	16.3	70	174	60	149	215	365		
R6340R-50	Three	50	190-220/380-415	3.0	14.4-13.4/7.2-6.8	65	162	75	187	180	306	112	51
		60	208-230/460	4.0	13-12/6	80	199	100	249	215	365		
R6P155Q-50	Single	50	220-240	4.0	20.8-19.1	65	162	80	199	235	399	243	110
		60	230	5.5	29.9	85	212	95	237	280	476		
R6P355R-50	Three	50	190-220/380-415	4.5	14.9-11/7.45-5.8	65	162	80	199	232	394	233	105
		60	208-230/460	6.0	20-18/9	85	212	100	249	280	476		
R7100R-50	Three	50	190-220/380-415	8.0	20.8-18.9/10.4-9.5	72	179	80	199	350	595	297	134
		60	208-230/460	10.0	26.5-24/12	90	224	90	224	420	714		

NOTICE: Performance specifications subject to change without notice.

VACUUM

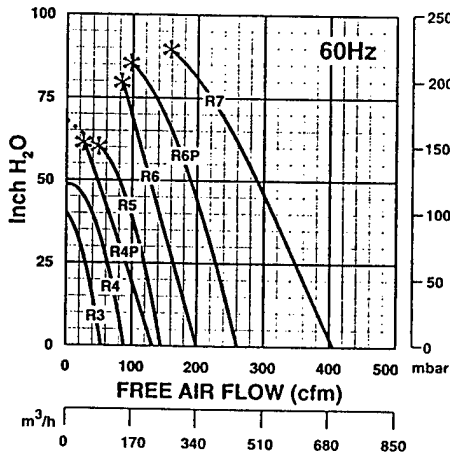
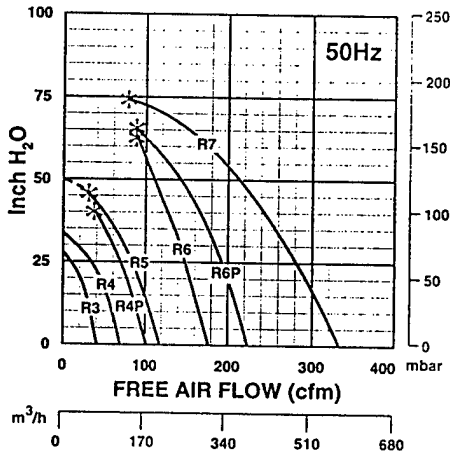

PRESSURE

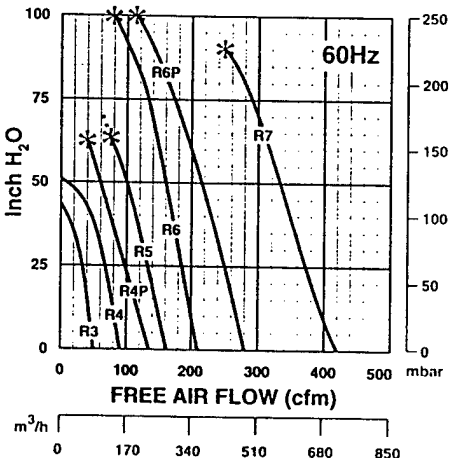
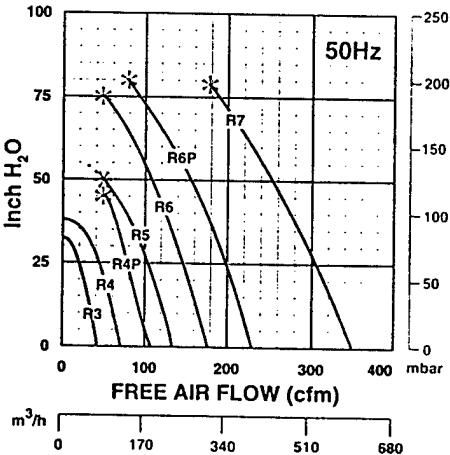

Free software identifies best Gast blowers for soil and groundwater remediation

Now you can size and select regenerative blowers and accessories for soil and groundwater remediation systems faster, easier and more accurately than ever before. Gast remediation system engineering software does the job and it is yours for the asking. The 3-1/2-inch IBM-compatible disk calculates performance when the blower is operating with both a vacuum and pressure load at the same time. The programs will also compensate for changes in performance from altitude and temperature, helping you identify the optimum Gast blowers for your application.

Call 1-800-952-4278 to receive your free remediation system engineering software.

SOIL VAPOR EXTRACTION PUMPS - REGENERATIVE BLOWERS

Model R3

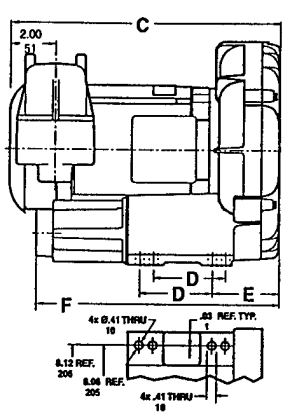

Models R6P, R7

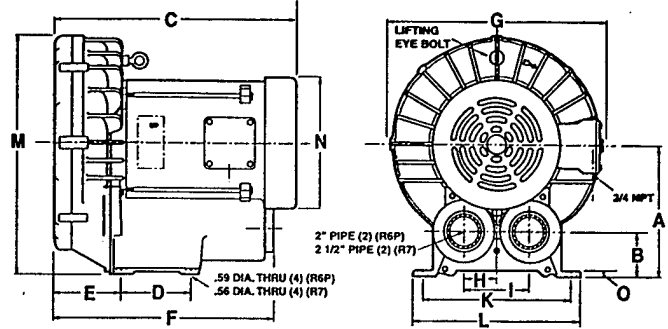

Models R4, R4P, R5, R6

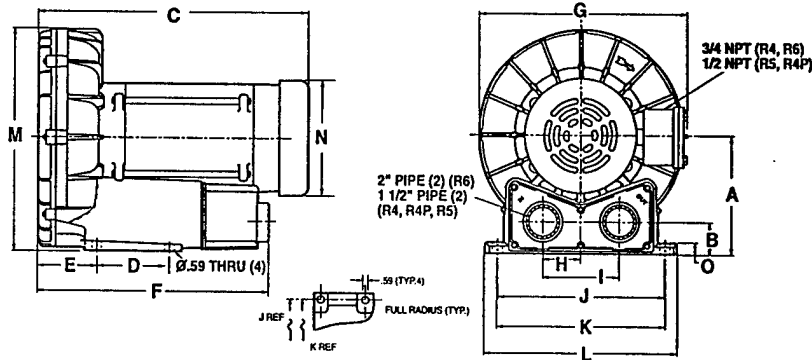

Product Dimensions Metric (mm) U.S. Imperial (inches)

Model	A	B	C	D	E	F	G	H	I	J	K	L	M	N	O
R3105N-50	131 5.17	35 1.37	310 12.20	83 3.25	80 3.03	281 11.06	324 12.75	49 1.94	99 3.88	205 8.06	206 8.12	238 9.38	258 10.15	-	13 .53
R4110N-50	157 6.18	43 1.68	389 15.30	95 3.75	72 2.85	316 12.44	313 12.31	50 1.98	101 3.96	225 8.86	227 8.93	254 10.00	293 11.73	175 6.88	11 .44
R4310P-50	157 6.18	43 1.68	356 14.03	95 3.75	72 2.84	316 12.44	313 12.31	50 1.98	101 3.96	225 8.86	227 8.93	254 10.00	293 11.73	175 6.88	11 .44
R4P115N-50	177 6.98	47 1.84	442 17.41	114 4.50	83 3.25	354 13.93	338 13.31	60 2.38	121 4.75	260 10.25	262 10.31	298 11.75	346 13.6	175 6.88	15 .60
R5125Q-50	178 7.00	46 1.82	445 17.50	114 4.50	91 3.58	361 14.22	344 13.56	60 2.38	121 4.75	260 10.25	262 10.31	298 11.75	350 13.78	173 6.81	15 .59
R5325R-50	178 7.00	46 1.82	423 16.66	114 4.50	91 3.58	361 14.22	344 13.56	60 2.38	121 4.75	260 10.25	262 10.31	298 11.75	350 13.78	183 7.19	15 .59
R6130Q-50	197 7.75	49 1.94	511 20.13	140 5.50	98 3.85	404 15.89	389 15.30	62 2.46	125 4.92	289 11.38	290 11.42	329 12.96	391 15.38	217 8.56	13 .52
R6340R-50	197 7.75	49 1.94	478 18.82	140 5.50	98 3.85	404 15.89	385 15.17	62 2.46	125 4.92	289 11.38	290 11.42	329 12.96	390 15.34	217 8.56	13 .52
R6P155Q-50	248 9.77	80 3.15	602 23.7	140 5.51	137 5.39	438 17.25	428 16.87	64 2.50	127 5.00	-	290 11.42	325 12.80	463 18.21	257 10.12	13 .50
R6P355R-50	248 9.77	80 3.15	554 21.80	140 5.51	137 5.39	438 17.25	428 16.87	64 2.50	127 5.00	-	290 11.42	325 12.80	463 18.21	257 10.12	13 .50
R7100R-50	274 10.79	92 3.64	577 22.72	216 8.50	212 8.33	545 21.46	457 18.00	100 3.94	200 7.88	-	375 14.76	410 16.14	509 20.02	257 10.12	14 .56

Notice: Specifications subject to change without notice.

Relief Valve

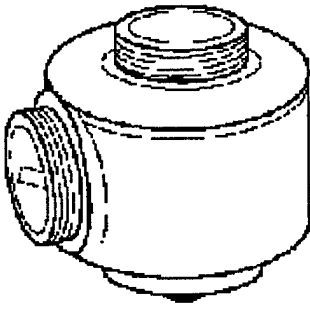

By setting a relief valve at a given pressure/vacuum, you can ensure excessive duties will not harm the blower or products in your application.

AG258	Relief valve	1½-inch NPT adjustable 30-200 inches H2O, vacuum or pressure, 200 CFM max
AG258F	Relief valve	2½-inch NPT adjustable 30-200 inches H2O, vacuum or pressure, 550 CFM max

[Print Form](#)

[Click Here for Catalog](#)

CONVERSION CHARTS

PRESSURE CONVERSION TABLE

Lbs. Per Sq. Inch	Atmospheres	Inches of Mercury	Millimeters of Mercury	Inches of Water	Meters of Water	Milli Bars	Kilopascals
1	.0680	2.036	51.71	27.73	.7037	69.0	6.895
14.70	1	29.92	760	407	10.33	1013.3	101.36
.4912	.0334	1	25.4	13.6	.3452	33.86	3.387
.0193	.001315	.03937	1	.5358	.0136	1.33	.13307
.0361	.00246	.0735	1.868	1	.0254	2.49	.24891
1.422	.0967	2.895	73.55	39.37	1	97.98	9.8047
14.50	.0009869	.02953	.750	.4018	.01021	1	.09998
.145	.00986	.29529	7.4996	4.0174	.10206	10.01	1

VOLUME FLOW CONVERSION TABLE

cfm	cfh	gpm	m ³ h	l/s
1	60	7.4805	1.6990	.47195
1/60	1	.12468	.02832	.007866
.13368	8.0208	1	.22712	.06309
.58858	35.315	4.4029	1	1/3.6
2.1189	127.13	15.850	3.6	1

Power and Heat Flow Conversion Table

hp(U.S.)	ft.lb/min	Btu/hr	Btu/min	W	kcal/min
1	33000	2544.4	42.407	745.70	10.686
.00030303	1	.07710	.001285	.02260	.0003238
.0003930	12.969	1	1/60	.29307	.004200
.02358	778.17	60	1	17.584	.25200
.00134	44.254	3.4121	.05687	1	.01433
.09358	3088.0	238.10	3.9683	69.780	1

Temperature Conversion Chart

°C = % (°F - 32)

Absolute Kelvin = °C + 273.15

°F = (%°C) + 32

Rankine °F = +459.67

TABLE EXAMPLE:

To Convert 100 °C to °F look up 100 read left

To Convert 100 °F to °C look up to 100 read right

to °F	From	to °C	to °F	From	to °C	to °F	From	to °C
-148.0	-100	-73.33	+50.00	+10	-12.22	161.6	72	22.22
-130.0	-90	-67.78	+53.6	+12	-11.11	165.2	74	23.33
-112.0	-80	-62.22	+57.2	+14	-10.00	168.8	76	24.44
-94.0	-70	-56.67	+60.8	+16	-8.89	172.4	78	25.56
-76.0	-60	-51.11	+64.4	+18	-7.78	176.0	80	26.67
-58.0	-50	-45.56	+68.0	+20	-6.67	179.6	82	27.78
-40.0	-40	-40.00	+71.6	+22	-5.56	183.2	84	28.89
-36.4	-38	-38.89	+75.2	+24	-4.44	186.8	86	30.00
-32.8	-36	-37.78	+78.8	+26	-3.33	190.4	88	31.11
-29.2	-34	-36.67	+82.4	+28	-2.22	194.0	90	32.22
-25.6	-32	-35.56	+86.0	+30	-1.11	197.6	92	33.33
-22.0	-30	-34.44	+89.6	+32	0.00	201.2	94	34.44
-18.4	-28	-33.33	+93.2	+34	+1.11	204.8	96	35.56
-14.8	-26	-32.22	+96.8	+36	+2.22	208.4	98	36.67
-11.2	-24	-31.11	+100.4	+38	+3.33	212.0	100	37.78
-7.6	-22	-30.00	+104.0	+40	+4.44	230.0	110	43.33
-4.0	-20	-28.89	107.6	42	5.56	248.0	120	48.89
-0.4	-18	-27.78	111.2	44	6.67	266.0	130	54.44
+3.2	-16	-26.67	114.2	46	7.78	284.0	140	60.00
+6.8	-14	-25.56	118.4	48	8.89	302.0	150	65.56
+10.4	-12	-24.44	122.0	50	10.00	320.0	160	71.11
+14.0	-10	-23.33	125.6	52	11.11	338.0	170	76.67
+17.6	-8	-22.22	129.2	54	12.22	356.0	180	82.22
+21.2	-6	-21.11	132.8	56	13.33	374.0	190	87.78
+24.8	-4	-20.00	136.4	58	14.44	392.0	200	93.33
+28.4	-2	-18.89	140.0	60	15.56	410.0	210	98.89
+32.0	0	-17.78	143.6	62	16.67	428.0	220	104.44
+35.6	+2	-16.67	147.2	64	17.78	446.0	230	110.00
+39.2	+4	-15.56	150.8	66	18.89	464.0	240	115.56
+42.8	+6	-14.44	154.4	68	20.00	482.0	250	121.11
+46.4	+8	-13.33	158.0	70	21.11			

North American Representatives and Distributors

A substantial stock of vacuum pumps, compressors, air motors, parts and accessories are carried by the offices listed below.

- (A) Distributor-plant-use sales only.
- (B) Manufacturers Representative - O.E.M. and plant-use sales.
- (C) Gast warehouse and sales office - O.E.M. and plant-use sales.
- (D) Gast service center.

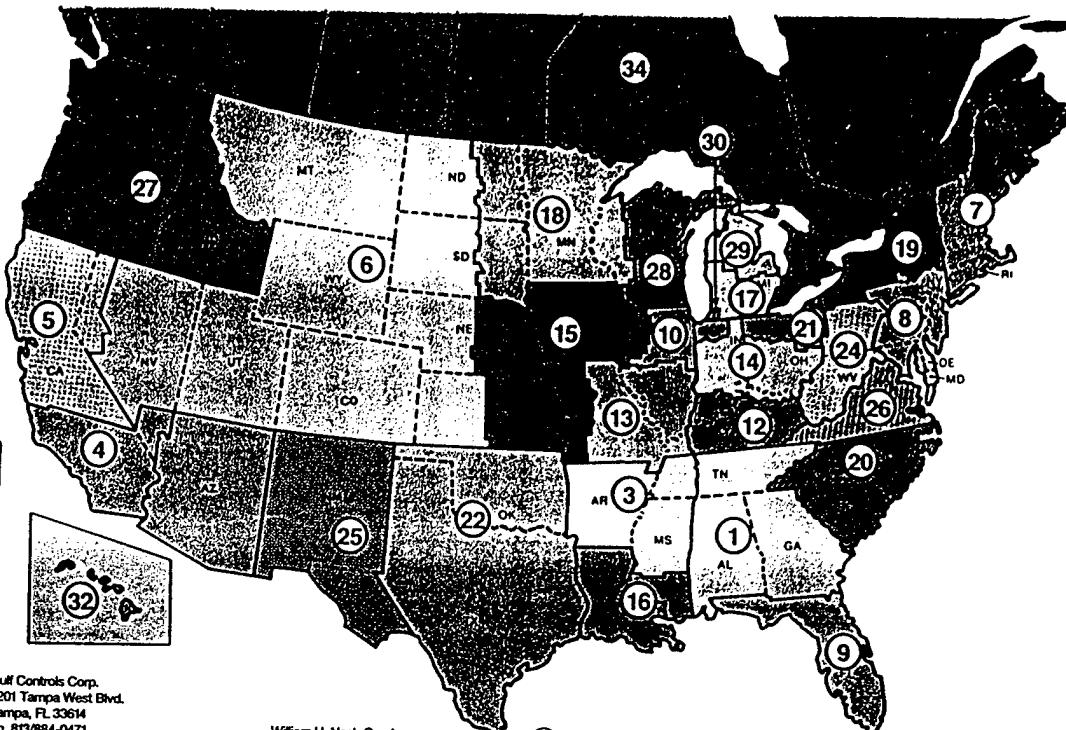

- 1 James E. Watson & Co.
(B) 29 Doran Ave.
Marietta, GA 30060
Ph. 404/422-1154
James E. Watson & Co.
Birmingham, AL
Ph. 205/663-6678
James E. Watson & Co.
Nashville, TN
Ph. 615/331-5716
- 3 Franklin Electrofluid Co., Inc.
(B) 3854 Watman
Memphis, TN 38118
Ph. 901/362-7504
Ph. 1-800-238-7500
Franklin Electrofluid Co., Inc.
(B) 8900 Crystal Hill Road
North Little Rock, AR 72113
AR only 1-800-272-5665
Ph. 501/771-4170
Franklin Electrofluid Co., Inc.
5609 South 14th Street
Fl. Smith, AR 72901
Ph. 501/646-7448
Ph. 1-800-264-7406
- 4 Brenner-Fiedler & Assoc., Inc.
(B,D) 13824 Bentley Place
Cerritos, CA 90701
Ph. 310/404-2721 &
Ph. 714/521-6280
Ph. 1-800-843-5558
Brenner Fiedler & Assoc., Inc.
(B) San Diego, CA
Ph. 619/232-9152
Ph. 1-800-843-5558
Brenner Fiedler & Assoc., Inc.
(B) 2117 South 48th Street #102
Tempe, AZ 85282
Ph. 1-800-638-0394
- 5 TECO Pneumatic, Inc.
(B) 1069 Serpentine Lane
Pleasanton, CA 94566
Ph. 510/426-8500
- 6 Fiero Fluid Power, Inc.
(B) Suite 104
10515 East 40th Ave.
Denver, CO 80239
Ph. 303/373-2600
Fiero Fluid Power, Inc.
(B) 2155 South Main
Salt Lake City, UT 84115
Ph. 801/467-4622
- 7 Ohlheiser Corp.
(B) 17 Rose Ave.
West Hartford, CT 06133-0332
Connecticut only 203/953-7632
New England States 1-800-858-9368
- 8 **GAST**
Gast Mfg. Corp.
(C,D) Eastern Sales Office
505 Washington Ave.
Carlstadt, NJ 07072
Ph. 201/933-8484
Ph. 212/563-1870 (NYC)
Dees Corp.
(A) 8860 Kelso Dr.
Baltimore, MD 21221
Ph. 410/574-2900
Die-A-Matic, Inc.
(A) 119 Brown St.
Pittston (Wilkes-Barre), PA 18640
Ph. 717/655-6831
Die-A-Matic, Inc.
(A) 650 N. State St.
York, PA 17403
Ph. 717/846-9300
Van-Air & Hydraulics, Inc.
(A) Philadelphia, PA
Ph. 215/923-2575
Van-Air & Hydraulics, Inc.
(A) 525 E. Woodlawn Ave.
Maple Shade, NJ 08052
Ph. 609/779-7300

- 9 Gulf Controls Corp.
(B) 5201 Tampa West Blvd.
Tampa, FL 33614
Ph. 813/884-0471
Ph. 1-800-282-9125
- 10 **GAST**
Gast Midwest Sales Office
(C) 755 N. Edgewood
Wood Dale, IL 60191
Ph. 708/960-7477
- 12 D & F Distributors
(B) 6309 Ulrich Avenue
Louisville, KY 40219
Ph. 502/968-0107
Ph. 1-800-45-PUMPS
D & F Distributors, Inc.
(B) 1144 Indy Court
Evansville, IN 47711
Ph. 812/867-2441
Ph. 1-800-45-PUMPS
- 13 John Henry Foster Co. Inc.
(B) 4700 Lebourget Drive
St. Louis, MO 63134-0820
Ph. 314/427-0000
Ph. 1-800-444-0522
- 14 Isaacs Fluid Power Equipment Company
(B) 8746 East 33rd Street
Indianapolis, IN 46226
Ph. 317/898-3486
Isaacs Fluid Power Equipment Company
Fl. Wayne, IN
Ph. 219/747-9604
Isaacs Fluid Power Equipment Company
(B) 1023 E. Fourth St.
Dayton, OH 45402
Ph. 513/228-7774
Isaacs Fluid Power Equipment Company
(B) 1840 Amberlawn Dr.
Cincinnati, OH 45237
Ph. 513/761-8855
Isaacs Fluid Power Equipment Company
(B) 923 Eastwind Drive, Suite 205
Westerville, OH 43081
Ph. 614/895-8540
- 15 Skarda Equipment Co., Inc.
(B) 2563 Farnam
Omaha, NE 68131
Ph. 1-800-228-9750
Ph. 402/422-0430
Skarda Equipment Co., Inc.
(B) 3545 Third Ave.
Marion, IA 52302
Ph. 1-800-228-9750
Skarda Equipment Co., Inc.
(B) Des Moines, IA
Ph. 1-800-228-9750
Skarda Equipment Co., Inc.
(B) 10139 Kaw Dr.
Edwardsville, KS 66113
Ph. 1-800-228-9750
Skarda Equipment Co., Inc.
(B) 313 N. Mathewson
Wichita, KS 67214
Ph. 1-800-228-9750
- 16 D & L Pumps, Inc.
(B) 2845 Sharon Street
Kenner, LA 70062
Ph. 504/467-2490
- 17 William H. Nash Co., Inc.
(B) 23910 Freeway Park Drive
Farmington Hills, MI 48335
Ph. 810/477-5800

- William H. Nash Co., Inc.
(B) 4134 36th Street S.E.
Grand Rapids, MI 49512
Ph. 616/949-4900
William H. Nash Co., Inc.
Flushing, MI
Ph. 810/732-7272
- 18 Midwest Machine Tool Supply
230 Commerce Circle South
Minneapolis, MN 55432
Ph. 612/571-3550
Ph. 1-800-327-9523
- 19 Kinequip, Inc.
(B) 365 Old Niagara Falls Blvd.
Buffalo, NY 14228-1636
Ph. 716/694-5000
Ph. 1-800-982-8894
Kinequip, Inc.
Johnstown, NY
Ph. 1-800-982-8894
Kinequip, Inc.
(B) Rochester, NY
Ph. 716/272-1590
Ph. 1-800-982-8894
Kinequip, Inc.
(B) Syracuse, NY 13211
Ph. 315/448-4115
Ph. 1-800-982-8894
- 20 Hydraulic & Pneumatic Sales
(B) 11100 Park Charlotte Blvd.
Charlotte, NC 28211
Ph. 704/588-3234
- 21 RAF Fluid Power, Inc.
(B) 23775 Mercantile Road
Cleveland, OH 44122-5990
Ph. 216/464-8930
- 22 Southwestern Controls
(B) 9912 B. East 45th Place
Tulsa, OK 74146-4752
Ph. 918/663-6777
Ph. 1-800-658-1570
Southwestern Controls
(B) 6720 Sands Point
Houston, TX 77074
Ph. 713/777-2626
Ph. 1-800-444-9368
Southwestern Controls
(B) 8808 Sovereign Row
Dallas, TX 75247
Ph. 214/638-4266
Ph. 1-800-444-9367
Southwestern Controls
(B) 859 Isom Road
San Antonio, TX 78216-4035
Ph. 210/340-4111
- 24 Allegheny Fluid Power, Inc.
(B) 112 Douglas Road
Sewickley, PA 15143
Ph. 412/367-5894
- 25 Mesa Equipment & Supply Company
(B) 3820 Commons, N.E.
Albuquerque, NM 87109
Ph. 505/345-0284
Mesa Equipment & Supply Company
(B) 1342 Lomaland Drive
El Paso, TX 79935
Ph. 915/594-4114

- 26 C.A. Weaver Co., Inc.
(B) 2420 Grenoble Road
Richmond, VA 23294
Ph. 804/672-6501
C.A. Weaver Co., Inc.
(B) 7562 Hi Tech Rd.
Roanoke, VA 24019
Ph. 703/563-9761
C.A. Weaver Co., Inc.
(B) 2430 Alabama Avenue
Norfolk, VA 23513
Ph. 804/857-8700
- 27 Air-Oil Products Corp.
(B) 6353 Sixth Ave. South
Seattle, WA 98108-3437
Ph. 206/767-7750
Ph. 1-800-282-2672
Ph. 206/762-4736
Air-Oil Products Corp.
(B) 2400 E. Burnside St.
Portland, OR 97214
Ph. 503/234-0866
Ph. 1-800-242-2672
Air-Oil Products Corp.
(B) 865 Conger Street
Eugene, OR 97401
Ph. 503/485-2022
Ph. 1-800-322-2672
- 28 Fluid System Components Inc.
(B) 3154 Gross St.
Green Bay, WI 54307
Ph. 414/337-0234
Fluid System Components Inc.
(B) 2315 South 17th Street
New Berlin, WI 53151-2701
Ph. 414/827-2700
- 29 J.E.M. Fluid Power, Inc.
(B) 2182 Dam Rd.
West Branch, MI 48661
Ph. 517/345-1180
- 30 **GAST**
Gast Mfg. Corp.
(C) 2300 Highway M-139
Benton Harbor, MI 49023-0097
Ph. 616/926-6171
- 32 C & F Machinery
(A) 91-060 Hanua Street
Kapolei, Hawaii 96707-1777
Ph. 808/682-1541
- 33 Games Industries, Inc.
(B) 6317 Nielson Way
Anchorage, AK 99518
Ph. 907/562-2933
- 34 CANADA
ONTARIO
Wainbee Ltd.
Windsor
Ph. 1-800-265-0929
Wainbee Ltd.
(B) 1590 Liverpool Court
Ottawa, Ontario K1B 4L2
Ph. 613/744-1720

- Wainbee Ltd.
(A,D) 5789 Coopers Ave.
Mississauga, Ontario L4Z 3S6
Ph. 905/568-1700
Ph. 905/568-0083
Wainbee Ltd.
(B) Unit 14
65 Trillium Park Place
Kitchener, Ont. N2E 1X1
Ph. 519/748-5391
Wainbee Ltd.
(B) 1909 Oxford Street East, Unit 45
London, Ont. N5V 4L9
Ph. 519/451-6266
Ph. 519/451-5566
QUEBEC
Wainbee Ltd.
(A,D) 215 Brunswick Blvd.
Pointe Claire, P.Q. H9R 4R7
Ph. 514/697-8810
Wainbee Ltd.
(B) 1990 Quest Blvd. Charest
Quebec City, P.Q. G1N 4K8
Ph. 418/683-1956
Wainbee Ltd.
(B) 1932 St. Paul Blvd.
Chicoutimi, P.Q. G7K 1H2
Ph. 418/698-4884
BRITISH COLUMBIA
Wainbee Ltd.
(B) 2221 Vauhall Place
Richmond, B.C. V6V 1Z5
Ph. 604/278-4288
Ph. 1-800-663-9829
ALBERTA
Wainbee Ltd.
(B) 10336 59th Avenue
Edmonton, Alta. T6H 1E5
Ph. 403/434-9528
Wainbee Ltd.
(B) 7407 44th St. S.E.
Calgary, Alta. T2C 3C8
Ph. 403/236-1133
MANITOBA
Wainbee Ltd.
(B) 1393 Border St. #4
Winnipeg, Man. R3H 0N1
Ph. 204/632-4558
Ph. 1-800-663-1393
MARITIME PROVINCES
Wainbee Ltd.
(B) 10 Thornhill Drive, Suite #5
Dartmouth, Nova Scotia
Halifax B3B 1S1
Ph. 902/468-1787
Ph. 1-800-667-1787
SASKATOON
Wainbee, Ltd.
437 34th Street
Saskatoon, Sask. S0S 0S9
Ph. 306/652-1433
NORTH BAY
Wainbee, Ltd.
1954 Main Street West
North Bay, Ont. P1B 8K5
Ph. 705/472-4244
Ph. 1-800-461-9534



Warranty

REGARDLESS OF CAUSE, if a product you buy from this brochure does not work right, Gast will repair or replace it once, at no charge, for up to one year from the date of shipment from the factory. In the course of repair or replacement, Gast may send you written recommendations on how to prevent a problem from happening again. Gast reserves the right to withdraw this warranty if you do not follow these recommendations. Customer is responsible for freight charges both to and from Gast in all cases. This warranty does not apply to electric motors, electrical controls, and gasoline engines, which Gast obtains from other manufacturers. A motor or engine carries only the warranty of the company that makes it.

THIS WARRANTY IS EXCLUSIVE AND IS IN LIEU OF ALL OTHER WARRANTIES, WHETHER WRITTEN, ORAL OR IMPLIED, INCLUDING THE WARRANTY OF MERCHANTABILITY AND OF FITNESS FOR ANY PARTICULAR PURPOSE. GAST'S LIABILITY IS IN ALL CASES LIMITED TO THE REPLACEMENT PRICE OF ITS PRODUCT. GAST SHALL NOT BE LIABLE FOR ANY OTHER DAMAGES, WHETHER CONSEQUENTIAL, INDIRECT, OR INCIDENTAL, ARISING FROM THE SALE OR USE OF ITS PRODUCTS.

Gast's sales personnel may modify this warranty, but only by signing a specific, written description of any modifications.

DISCLAIMER

The information presented in this catalog is based on technical data and test results of nominal units. It is believed to be accurate and is offered as an aid in the selection of Gast products. It is the user's responsibility to determine suitability of the product for his intended use and the user assumes all risk and liability whatsoever in connection therewith.

APPENDIX C
DATA COLLECTION SHEETS

