

# LOAN DOCUMENT

PHOTOGRAPH THIS SHEET

⑥

DTIC ACCESSION NUMBER

LEVEL

INVENTORY

*Work Plan for a Treatability Study*

DOCUMENT IDENTIFICATION  
*Jun 93*

**DISTRIBUTION STATEMENT A**  
Approved for Public Release  
Distribution Unlimited

DISTRIBUTION STATEMENT

ACCESSION FOR	
NTIS	GRAM
DTIC	TRAC
UNANNOUNCED	
JUSTIFICATION	
BY	
DISTRIBUTION/	
AVAILABILITY CODES	
DISTRIBUTION	AVAILABILITY AND/OR SPECIAL
A-1	

DISTRIBUTION STAMP

DATE ACCESSIONED

DATE ACCESSIONED

DATE RETURNED

DATE RETURNED

20001122 028

DATE RECEIVED IN DTIC

REGISTERED OR CERTIFIED NUMBER

REGISTERED OR CERTIFIED NUMBER

PHOTOGRAPH THIS SHEET AND RETURN TO DTIC-FDAC

H  
A  
N  
D  
L  
E  
  
W  
I  
T  
H  
  
C  
A  
R  
E

**Work Plan for a  
Treatability Study in Support of the  
Intrinsic Remediation (Natural Attenuation) Option at  
Pumphouse 5 (Building 771)**



**Griffiss Air Force Base  
Rome, New York**

Prepared For

**Air Force Center for Environmental Excellence  
Technology Transfer Division  
Brooks Air Force Base  
San Antonio, Texas**

and

**416 CGS/DEV  
Griffiss Air Force Base  
Rome, New York**

June 1995

 **PARSONS  
ENGINEERING SCIENCE, INC.**

1700 Broadway, Suite 900 • Denver, Colorado 80290

*AQMO1-01-0312*

**DEFENSE TECHNICAL INFORMATION CENTER  
REQUEST FOR SCIENTIFIC AND TECHNICAL REPORTS**

Title AFCEE Collection

1. Report Availability (Please check one box)  
 This report is available. Complete sections 2a - 2f.  
 This report is not available. Complete section 3.

2a. Number of Copies Forwarded  
1 each

2b. Forwarding Date  
July/2000

2c. Distribution Statement (Please check ONE box)  
DoD Directive 5230.24, "Distribution Statements on Technical Documents," 18 Mar 87, contains seven distribution statements, as described briefly below. Technical documents MUST be assigned a distribution statement.  
 DISTRIBUTION STATEMENT A: Approved for public release. Distribution is unlimited.  
 DISTRIBUTION STATEMENT B: Distribution authorized to U.S. Government Agencies only.  
 DISTRIBUTION STATEMENT C: Distribution authorized to U.S. Government Agencies and their contractors.  
 DISTRIBUTION STATEMENT D: Distribution authorized to U.S. Department of Defense (DoD) and U.S DoD contractors only.  
 DISTRIBUTION STATEMENT E: Distribution authorized to U.S. Department of Defense (DoD) components only.  
 DISTRIBUTION STATEMENT F: Further dissemination only as directed by the controlling DoD office indicated below or by higher authority.  
 DISTRIBUTION STATEMENT X: Distribution authorized to U.S. Government agencies and private individuals or enterprises eligible to obtain export-controlled technical data in accordance with DoD Directive 5230.25, Withholding of Unclassified Technical Data from Public Disclosure, 6 Nov 84.

2d. Reason For the Above Distribution Statement (in accordance with DoD Directive 5230.24)

2e. Controlling Office  
HQ AFCEE

2f. Date of Distribution Statement Determination  
15 Nov 2000

3. This report is NOT forwarded for the following reasons. (Please check appropriate box)  
 It was previously forwarded to DTIC on ..... (date) and the AD number is .....  
 It will be published at a later date. Enter approximate date if known. ....  
 In accordance with the provisions of DoD Directive 3200.12, the requested document is not supplied because: .....

Print or Type Name  
Laura Peña  
Telephone  
210-536-1431

Signature  
Laura Peña  
(For DTIC Use Only)  
AQ Number 401-01-0312

June 3, 1995

Cathy Jerrard  
AFBCA/OL-X  
Environmental Section  
153 Brooks Road  
Griffiss AFB, NY 13441-4105

Subject: Response to Comments on the "Intrinsic Remediation Treatability Study (TS) for Pumphouse 5", Griffiss AFB, New York.

Dear Ms. Jerrard:

Parsons Engineering Science, Inc. (Parsons ES, formerly Engineering-Science, Inc.) is pleased to submit this letter in response to two sets of comments. This letter addresses comments from Jonathan Greco, Bureau of Eastern Remedial Action of the New York Department of Environmental Conservation (NYDEC) dated 30 May 1994 and comments from Mr. Douglas M. Pocze, Project Manager, EPA Region II dated May 26, 1995.

We found these comments both constructive and informative. Any further comments regarding this intrinsic remediation project will be addressed in the final TS report. Field activities as part of this demonstration project will begin on June 5, 1995. If you have any comments, or if we can be of further assistance, please do not hesitate to call Todd Wiedemeier or Todd Herrington at (303) 831-8100.

Respectfully,

 for

Todd H. Wiedemeier  
Project Manager



R. Todd Herrington  
Project Engineer

Attachment

cc: Lt. Col. Ross N. Miller, AFCEE  
Mr. Douglas Downey, Parsons ES  
File 722450.07 Letters

**I. Response to comments submitted by Mr. Jonathan Greco, Bureau of Eastern Remedial Action, Division of Hazardous Waste Remediation, at the New York State Department of Environmental Conservation, received May 30, 1995.**

1. Page 1-1: Bioplume II should be submitted to New York State for review of modeling parameters.

**Response:** A listing of Bioplume II modeling parameters accompanied with input and output files will be submitted as part of the final treatability study (TS) report. Bioplume II code and instruction manuals can be sent earlier than the final TS report if requested by the state.

2. Page 1-1: What is the "Health & Safety Plan for the Bioplume II Modeling Initiative?"

**Response:** The Health & Safety Plan for the Bioplume II Modeling Initiative is a plan to establish personnel protection standards and mandatory safety practices for all personnel employed on the Bioplume II modeling project at United States Air Force Installations (U.S. Air Force) across the United States. Parsons Engineering Science, Inc. (formerly known as Engineering-Science, Inc.) has prepared this program health and safety plan specifically to conduct supplemental site characterization in support of Bioplume II modeling at selected installations contaminated with petroleum hydrocarbons.

3. Page 1-1: Do downgradient receptors include fish and wildlife: What about environmental resources (e.g., surface water, sediments, groundwater, etc.)?

**Response:** We assess potential risk to potential downgradient receptors by completing an exposure pathway analysis to a potential exposure point. No specific receptors, including indicator ecological receptors, are quantitatively considered in this analysis. Rather, our approach emphasizes a quantitative analysis of chemical fate in the environment over time, and to determine if there are any potential downgradient exposure points. Inference to a quantitative risk assessment in the workplan has been deleted and the second paragraph on page 1-1 changed to the following:

"Data collected during the TS will also be used as input into the Bioplume II groundwater solute-transport model code. As part of the TS, the Bioplume II modeling effort has two primary objectives: 1) to predict the future extent and concentration of the dissolved contaminant plume by modeling the effects of advection, dispersion, sorption, and biodegradation; and 2) to provide technical support for selection of the intrinsic remediation option as the best remedial alternative at regulatory negotiations, as appropriate. The TS and the Bioplume II modeling effort for the Pumphouse 5 site will involve completion of several tasks, which are described in the following sections."

4. General (Section 1.1): What is the "site" (e.g., the whole area, just the tanks, etc.). Obviously, this is important in terms of future sampling locations, as well as for the overall scope of the project.

**Response:** The "site" refers to all areas containing groundwater impacted by fuel releases from Pumphouse 5 USTs and infrastructure (e.g., valve pits, fuel collection drains) needed for operation. Potential contamination emanating from the tarmac and/or lateral control pits are not under the scope of work for this project. Reference to the Pumphouse 5 site in the first paragraph of Section 1.1 has been changed to read the following (in bold):

"... This work plan describes the site characterization activities to be performed in support of the TS and the Bioplume II modeling effort. Field activities will be performed to determine the extent of residual, free phase, and dissolved contamination at the Pumphouse 5 site. **The Pumphouse 5 site includes all areas impacted by contaminated groundwater as a result of fuel releases by USTs and infrastructure (e.g., valve pits and fuel collection drains) associated with Pumphouse 5. Other potential sources or contamination emanating from the tarmac or lateral control pits are not under the scope of this project.** Data collected from field activities will be used along with data from previous investigations to complete the characterization of contaminants at the site and for use in the Bioplume II model to predict the future concentrations and extent of contamination."

5. Page 1-9 (Section 1.1): In April 1993, 11.45' of product was measured in well 7. This is not included in the summary. Table 2-1 of the February 1995 EE/CA should be included in this document.

**Response:** Agree; the revised Table 2-1 will be included in Appendix B of the workplan. The error in Table 2.4 of the Parsons ES workplan showing free product thickness at monitoring well 771MW-7 being 1.45 instead of 11.45 was a result of erroneous data in previous drafts (before February 1995) of the Pumphouse 5 EE/CA submitted by Law. The February edition of the Law report was not available during the writing of this workplan. The table will be corrected in the final TS report.

6. Page 1-10 (Section 1.1): Please explain how rain and melt cause a valve to back-up? Isn't it more likely that the seasonally high groundwater "pushes" floating product into the pits?

**Response:** The description of the possible valve malfunction were confusing in the Prefinal EE/CA submitted by Law in January 1995. The description in the Law report inferred that elevated water levels caused a valve malfunction to release additional fuels into the valve pits. However, we agree that unseasonably high groundwater levels pushing floating product into the pits is reasonable and this comment has been incorporated into the last paragraph of page 1-10 to read as follows (additional text in bold):

"The valve pits located northwest of the pumphouse (Figure 1.4) have released fuel contamination in response to precipitation or snowmelt filling the valve pit and clogging the valve system (Law, 1995). **Seasonally high groundwater elevations may also have pushed floating product from the surrounding**

**formation into the pits.** The valve pits are constructed of crushed-stone bottoms, and are a preferential route into the. . .”

7. General (Section 2.1): How does the Air Force reconcile the conclusion of the EE/CA (which states natural attenuation is not an option at pumphouse 5) with this study's objective.

**Response:** The conclusion of the EE/CA that natural attenuation is not a viable option at the Pumphouse 5 site does not change the objective of this report. Sufficient evidence was not collected under the previous EE/CA to document the potential for natural attenuation of contaminants in accordance with natural attenuation protocols published by AFCEE in conjunction the EPA Robert S. Kerr Research Laboratories (Ada, Oklahoma).

8. Tables 2-1 & 2-2 (Section 2.1): It is unclear how the groundwater elevations were determined without the ground surface elevation or depth to water being known. Perhaps this is the cause of the erratic flows shown. Also, Law Environmental used wells with free product to calculate flow direction. This may also be the cause of the erratic flows shown.

**Response:** Groundwater elevations were estimated on incomplete data from available boring logs, well completion diagrams, and water level data from previous reports contained in Appendix B. Groundwater depths and monitoring well locations and depths will be remeasured during our June 1995 field effort. In the event that free product is present in monitoring wells, groundwater elevations will be corrected for the effects of floating free product.

9. Page 2-22 (Section 2.1.3): The characterization of the analyzed petroleum as slightly weathered has been questioned by the NYSDEC in the past (see my November 16, 1994 comment letter; No. 11, attached). No acceptable response has been given.

**Response:** We agree that a total petroleum hydrocarbon scan (i.e., SW8015M) of the “weathered” fuel compared to a scan of “fresh” fuel is required to quantitate actual weathering of the fuel. However, the description in the last paragraph in Section 2.1.3 (Page 2-22) is a qualitative observation of fuel weathering based on observed losses of both low (C3 to C5) and high (C14-C19) molecular weight hydrocarbons. The statement was intended to inform the reader that relatively fresh fuels exist at the site, but have undergone slight environmental exposure.

10. Table 2-6 (Section 2.1.4): BTEX levels alone will not be the sole parameter for judging the contaminant degradation at this site. It must be demonstrated that all organic compounds are within standards, including UOCs (unspecified organic compounds).

**Response:** We agree that other organic compounds, specifically semivolatile compounds, are equally important in assessing the effectiveness of natural attenuation at a fuel contaminated site. However, the emphasis of using BTEX as indicator compounds is derived from their high solubility and toxicity relative to other JP-4 hydrocarbons. For these reasons, the focus of this natural attenuation demonstration project (as reflected by our scope of work from AFCEE) is to

document the extent of contaminant migration and to predict groundwater concentrations using BTEX as indicator compounds. BTEX compounds are more mobile than other compounds, such as naphthalene, so the monitoring of BTEX is generally considered more conservative than monitoring a naphthalene plume.

Additional samples for semivolatile analysis of groundwater using SW8270 will be collected at up to 5 additional wells at the site, in the downgradient direction of groundwater flow. Assuming a successful demonstration of natural attenuation at the site, point of compliance (POC) limits at proposed POC wells may be modified to include other unspecified organic compounds (e.g., semivolatile compounds) measured during long-term annual or semi-annual groundwater sampling.

11. Page 2-34, bottom of page (Section 2.2.3): It is stated that Bioplume II will simulate the breakdown of BTEX at the site and will be used to predict the concentration and extent of the contaminant plume over time. What is to be said about the other compounds for which the Air Force is sampling and, more importantly, are known to exist in high concentrations at the furthest downgradient well (771MW-4). Is it to be assumed these compounds will degrade in the same manner as BTEX? Is there evidence indicating Acetone, Methyl-Ethyl Ketone, Naphthalene, and Phenol will behave as the BTEX.

**Response:** We do not assume the other UOCs are any more or less biodegradable because the biodegradation of select compounds is very site-specific. As stated in the response to comment 10, additional analyses will be performed as part of this project to quantitate non-BTEX, volatile and semi-volatile compounds. Selection of POC limits at POC wells may reflect the presence of these compounds. In addition, these compounds are subject to abiotic attenuation processes such as sorption, dispersion and dilution. These factors will be considered when evaluating the fate of these compounds and designing a POC sampling plan.

12. General (Section 2.2.4): 771MW-4, one of the most contaminated dissolved phase wells of those listed in Table 2-5 of Appendix A is located only 90 feet away from Rainbow Creek. A site walkover performed on May 16 indicated an apparent petroleum sheen in the creek, which is obviously downgradient of 771MW-4. I suggest sampling surface water and sediments at three locations (i.e., upgradient, assumed impacted zone and downgradient of the site). If this data shows negative impacts (i.e., significant contamination) upon the creek, I see no further reason to go on with a full-blown modeling effort of the groundwater; rather the surface water pathway should then be assessed. For example, does Rainbow Creek discharge to Six Mile Creek? If so, how? What are the potential impacts of these assumed releases?

**Response:** The scope of work for the natural attenuation demonstration project is to fully define the vertical and lateral extent of groundwater contamination and to collect the groundwater and soil data needed to document current and predicted effects of natural attenuation of BTEX compounds dissolved in groundwater at the site. Up to two additional sediment and/or surface water samples may be taken to collect data in support of other potential remedial designs. These data will be considered as part of the final recommended remedial approach to the site whether

it be natural attenuation alone or natural attenuation coupled with other technologies such as air-sparging, bioventing, or a risk-based remediation.

13. General (Section 2.2.4): The existing monitoring wells should be probed for free product/product thickness. All wells not exhibiting product should be measured for groundwater elevation, as this is more reliable data than the elevations which will be obtained from the hydronunch locations.

**Response:** Section 3.2.5 of this workplan states that groundwater levels in all existing monitoring wells and newly installed monitoring points will be measured during the site visit.

14. Section 2.2.5: I know of no definitive plan for the removal of LNAPL from the Pumphouse 5 Area; please elaborate.

**Response:** Intended LNAPL removal operations are part of the source removal project for the site. A bioslurping effort headed by AFCEE will be initiated at the site in June 1995, or later in the summer. Excavation of the source and potential LNAPL in soil will occur early next spring (1996).

15. Sections 3.2.2.3.1 and 3.2.2.3.2: These sections discuss deep and shallow monitoring points, however, it is unclear from Figure 3.3 which are to be used and where. Please explain. Also, are well screens meant to straddle the water table?

**Response:** Figure 3.3 will be clarified to show the location of proposed deep and shallow monitoring points. Shallow monitoring points will be screened across the water table, while deep screen will be placed 8 to 10 feet below the water table.

16. Figure 3.3: I would like to see an additional sample point placed immediately north-northwest of monitoring well 771-MW4 (in between the two locations already depicted and in a direct line with the sample on the far side of Rainbow Creek).

**Response:** Additional sampling locations have been added to Figure 3.3 to satisfy your request for additional sampling points and to maintain a sampling line toward the creek.

17. General: I am unable to complete my review of the adequacy of the sampling locations until the site is properly defined. For example, is the site definition Pumphouse 5 and its immediate environment, or is it to include the tarmac and all lateral control pits?

**Response:** See the response to comment 4.

## **II. Response to comments from Mr. Douglas M. Pocze, Project Manager, US EPA, submitted May 26, 1995.**

Cover Letter Comment: One major comment concerns the previous sampling performed at Pumphouse 5. It is my understanding that Law Environmental performed sampling to

delineate free product at this area. However, the results of this sampling event were not available for my review. Because reviewing the results of Law's investigation would greatly assist in the first phase of this treatability study, namely the site characterization, and prevent duplication of work, it would be beneficial to review this information as soon as possible and prior to implementing the study.

**Response:** Previous attempts to define LNAPL extent occurred in soil gas studies in 1989 and 1991 and with free-product measurements at monitoring wells 771MW-1 to 771MW-9 from June 1989 to January 1995. The results of these studies were summarized in Section 2 of the workplan. Cathy Jerrard of GAFB has mentioned in telephone communications that recent data taken by Law Environmental that further defines contamination in media at the site will be available by June 2. This data will be reviewed prior to the commencement of field activities on June 5.

1. Page 1-17: A clear description of the units involved should be provided. During our May 9 meeting in Albany, New York, concern was raised about the amount of piping involved and the lateral control pits. Could these sites be contributing to the source of free product and would it be beneficial to address these areas with Pumphouse 5.

**Response:** Page 1-17 is not present in this workplan (page 1-7 perhaps?). We assume this question is directed toward potential contaminant sources at the site. Any potential spill source unrelated to the USTs and immediate infrastructure of Pumphouse 5 are not covered within the scope of this workplan (See the response to comment 4 of the NYDEC comments). Dig permits and other relevant infrastructure diagrams will be obtained in the field.

2. A flow diagram specific to the activities at Pumphouse 5 should be developed and provided. The agency is concerned the various activities occurring at Pumphouse 5 (treatability study, free product removal through bioslurping, and the removal of the pumphouse) are not coordinated. A flow diagram of the activities planned for Pumphouse 5 would clarify the remediation process.

Furthermore, although different people are performing the different activities at the pumphouse, each person needs to be aware of the other's activities and information collected.

**Response:** Agree; all field activities should be coordinated between different consultants and agencies. Cathy Jerrard of GAFB has agreed (through telephone communication) to create a schedule of all proposed field activities at the site.

3. Page 1-2, What is sensitivity analysis?

**Response:** A sensitivity analysis is a tool used in computer modeling that helps quantify the uncertainty in a model calibration by observing changes in modeled output produced by specific changes in model input parameters. Greater detail describing the sensitivity analysis will be provided in the final TS report.

4. Page 1-3 (and throughout the document), it is implied that other remedial options will be investigated if natural attenuation does not work. However, it is my understanding that other remedial options such as the removal of the pumphouse and free product are to be implemented regardless of the success of natural attenuation. Natural attenuation is to address the remaining contamination or contamination in the dissolved phase. If this statement is not the understanding of Griffiss, then another meeting is necessary to discuss the overall remediation of Pumhouse 5.

**Response:** Agree; this statement is true. GAFB personnel understand that natural attenuation is intended to complement the other remedial actions. Another meeting is not needed.

5. Page 1-3: Working off the background information implies that the base is still operational. Since the air force is no longer using the base, this description should be revised.

**Response:** Major military activities at the Base have drastically been reduced; however, all runways at the Base are still active and receive military aircraft from other bases. As stated in Section 1.2, the Base is scheduled for complete realignment by September 30, 1995.

6. Page 1-9: The reference to free product in the "phreatic surface" implies that this free product is different than the existing free product. Please clarify this statement.

**Response:** Agree, "phreatic surface" will be changed to minimize confusion. The first full sentence on page 1-9 now reads:

"...Additionally, a 0.1-foot-thick free product layer was encountered in monitoring well 771MW-1 on June 29, 1989."

7. Please explain the use of the "valve pits." Also I would expect that piping would be connected to the valve pit; however, the diagrams (i.e., Figure 2-14) do not indicate that they are connected. Please clarify this issue.

**Response:** Agree, piping is connected to the valve pits; however, available diagrams used for this report do not indicate the location of piping connecting the USTs to the valve pits. Additional description on the use of valve pits has been included in the final paragraph on page 1-10 and reads (in bold):

"...response to precipitation or snowmelt filling the valve pit and clogging the valve system (Law, 1995). **The valve pits are used for isolation or diversion valves required for UST operation or for future expansion fuel storage operations.** Seasonally high groundwater elevations may also have pushed floating product from..."

8. Page 2-17: What is the statement referring to the USTs implying: Are USTs a problem in this area? Please clarify this statement.

**Response:** Agree, the ending of the paragraph at the top of page 2-17 now reads (changes in bold):

“...surface coverage are believed to be significant causes of erratic groundwater flow direction. **An uncertain number of the four USTs buried at the site are partially beneath the water table (Jerrard, 1995).** Layers of silty sand and clayey sand at 6 to 19 feet bgs (observed at boreholes 771MW-4, . . .”

9. Page 2-20: Refers to the results of a soil gas survey. Previous discussions of the soil gas surveys have raised various inconsistencies and therefore, soil gas results should be used with other supporting data and not independently.

**Response:** Agree, soil gas results will be used with other supporting data collected in the June 1995 field effort as part of the final TS report.

10. Page 2-25 (1st pp, last line): How do groundwater elevation diagrams define the extent of groundwater contamination? Perhaps the reference should be to Figure 2-10 or 2-11 and not Figure 2-9.

**Response:** As stated in Section 2.1.2.2 of the workplan, groundwater elevations are very erratic and flow in northern, western, and southern directions depending on location. Reference to soil gas results shown in Figure 2-10 and 2-11 are not necessarily indicative of LNAPL migration. Residual-phase hydrocarbons trapped in the vadose zone can also give positive results. Groundwater elevations will be remeasured in the June 1995 field work. Please see comment 8 from the NYDEC.

11. Page 2-25 (2nd pp, 4th/5th line): How does the positive results for naphthalene and 2-methylnaphthalene affect the natural attenuation design? What alterations do you propose to address these and other constituents in addition to BTEX?

**Response:** See the response to comment 10 from the NYDEC.

12. Page 2-32: Based on previous testing of biodegradation models and prior to our site specific model study, are there any generic degradation rates anticipated over 1 year? 2 years? 5 years? 10 years?

**Response:** Biodegradation rates will be estimated on the basis of groundwater data to be collected in the June field effort. Biodegradation rates are very site specific; however, first-order biodegradation rates estimated from other related sites under AFCEE's natural attenuation demonstration initiative often range from 0.01 to 0.001 day<sup>-1</sup>.

13. Page 2-33: Are there any regulatory concurrence or endorsements of the Bioplume II model? How will the Bioplume III model affect the treatability study? Will simultaneous models using Bioplume II and III be calculated?

**Response:** Bioplume II does not have any regulatory endorsements. However, Bioplume II is based on a two-dimensional solute transport and dispersion model

created by Konikow and Bredehoeft (1979) which is often cited in literature. Bioplume II was also developed in conjunction with efforts by the US EPA Robert S. Kerr Research Laboratories (RSKERL) in Ada, Oklahoma. The relative homogeneity of soils at the Pumphouse 5 site and the high saturated thickness make the site ideally suited for a two-dimensional groundwater model (i.e., Bioplume II). Bioplume III (yet to be released) is supposed to be a three-dimensional model capable of simulating multiple electron acceptors concentrations used in aerobic and anaerobic biodegradation. Simultaneous model using Bioplume II and Bioplume III will not be performed.

14. Does the Bioplume model calculate current conditions or does it also perform calculations of future expected conditions?

**Response:** Bioplume II is a predictive model and will be used to estimate future contaminant concentrations in groundwater. Current contaminant concentrations will be used to help calibrate the model to match the contaminant hydrogeology at the site.

15. Page 2-34 (last paragraph): As stated earlier, we are also concerned with other constituents besides BTEX. The treatability study and natural attenuation model should also consider other constituents when attempting to show the success of natural attenuation.

**Response:** Please see the response to comment 10 from the NYDEC. Modified sampling and POC strategies will be initiated as part of the natural attenuation study to deal with non-BTEX compounds.

16. Page 2-25 (Section 2.2.4): Before identifying "potential preferential contaminant migration pathways," Griffiss should first identify if this information is already available (e.g., RI report) rather than duplicating work.

**Response:** We agree. Cathy Jerrard of GAFB will provide any risk-assessment or other applicable data from previous reports to Parsons ES as part of the data base for the TS report.

17. Page 2-36 (2nd page): States that the pumphouse excavations scheduled for the "summer of 1985 or spring of 1996." I believe "1985" is a misprint.

**Response:** Agree, the second to last paragraph on page 2-36 now states:

" . . . Excavation activities will be performed in the summer of 1995 or spring of 1996 to remove LNAPL contamination and contaminated soils in and around Pumphouse 5 (Jerrard, 1995) . . ."

18. Page 3-1 identifies the data which will be collected during the site investigation. However, as stated earlier, the chemical analysis should include other constituents besides BTEX (i.e., naphthalene or glycol). Please revise and clarify this section and Table 3.1. Also should the parameters listed in Table 3.1 match the information collected on the ground water sampling record (Figure 3.6)?

**Response:** Please see comment 10 from the NYDEC. Table 3.1 will be revised to include analysis for semi-volatile compounds (SW8270). The groundwater sampling record is more specifically designed for groundwater observations and analyses in the field (using Hach analysis methods) and will not necessarily reflect every analysis stated in Table 3.1.

19. Page 3-25: Based upon our discussion of natural attenuation on May 9 and material provided, manganese was not mentioned as an indicator parameter. although it may contribute to degradation through the benzene oxidation equation, please provide information as to the formation of the manganese ion and its impact to natural attenuation as an indicator parameter. Also provide any other Air Force Base Studies concerning this monitored parameter.

**Response:** Manganese has more recently been identified as a potentially important electron acceptor in anaerobic biodegradation processes. Little information currently is available to document the influence of manganese on hydrocarbon biodegradation. Manganese will be measured in the field to determine its relative influence as an electron acceptor at the site. The results of our analysis will be presented in the final TS report. If the time frame for the receipt of this information is too late, some additional material could be sent to you upon your request.

**WORK PLAN FOR A TREATABILITY STUDY  
IN SUPPORT OF THE INTRINSIC REMEDIATION  
(NATURAL ATTENUATION) OPTION FOR  
PUMPHOUSE 5 (BUILDING 771)**

at

**GRIFFISS AIR FORCE BASE  
ROME, NEW YORK**

**June 1995**

Prepared for:

**AIR FORCE CENTER FOR ENVIRONMENTAL EXCELLENCE  
TECHNOLOGY TRANSFER DIVISION  
BROOKS AIR FORCE BASE  
SAN ANTONIO, TEXAS**

AND

**416 CES/CEV  
GRIFFISS AIR FORCE BASE  
ROME, NEW YORK**

Prepared by:

**Parsons Engineering Science, Inc.  
1700 Broadway, Suite 900  
Denver, Colorado 80290**

## CONTENTS

	Page
1 INTRODUCTION.....	1-1
1.1 SCOPE OF CURRENT WORK PLAN.....	1-2
1.2 BACKGROUND.....	1-3
2 DATA REVIEW AND CONCEPTUAL MODEL DEVELOPMENT.....	2-1
2.1 DATA REVIEW.....	2-1
2.1.1 Topography, Surface Hydrology, and Climate.....	2-1
2.1.2 Overview of Geology and Hydrogeology.....	2-3
2.1.2.1 Regional Geology and Hydrogeology.....	2-3
2.1.2.2 Site Geology and Hydrogeology at Building 771.....	2-8
2.1.3 Soil Quality.....	2-17
2.1.4 Groundwater Quality and Chemistry.....	2-22
2.2 Development of Conceptual Model.....	2-31
2.2.1 Intrinsic Remediation and the Bioplume II Model.....	2-32
2.2.2 Biodegradation of Dissolved BTEX Contamination.....	2-33
2.2.3 Initial Conceptual Model.....	2-34
2.2.4 Potential Pathways and Receptors.....	2-35
2.2.5 Anticipated Remedial Action Plans Unrelated to Griffiss AFB TS.....	2-36
3 COLLECTION OF ADDITIONAL DATA.....	3-1
3.1 SOIL SAMPLING.....	3-3
3.1.1 Sample Collection Using the Geoprobe® System.....	3-3
3.1.2 Soil Sample Locations and Required Analyses.....	3-5
3.1.3 Datum Survey.....	3-8
3.1.4 Site Restoration.....	3-8
3.1.5 Equipment Decontamination Procedures.....	3-8
3.2 GROUNDWATER SAMPLING.....	3-9
3.2.1 Monitoring Point Locations and Completion Intervals.....	3-9
3.2.2 Monitoring Point Installation Procedures.....	3-10
3.2.2.1 Pre-Placement Activities.....	3-10
3.2.2.2 Monitoring Point Materials Decontamination.....	3-10
3.2.2.3 Installation and Materials.....	3-11

3.2.2.3.1	Deep Monitoring Points.....	3-11
3.2.2.3.2	Shallow Monitoring Points.....	3-11
3.2.2.4	Monitoring Point Completion.....	3-12
3.2.2.5	Monitoring Point Abandonment and Site Restoration .....	3-14
3.2.2.6	Monitoring Point Development and Records .....	3-14
3.2.3	Groundwater Grab Sampling Procedures .....	3-15
3.2.4	Monitoring Point Location and Datum Survey .....	3-15
3.2.5	Water Level Measurements.....	3-17
3.3	GROUNDWATER SAMPLING.....	3-17
3.3.1	Preparation for Sampling .....	3-18
3.3.1.1	Equipment Cleaning .....	3-18
3.3.1.2	Equipment Calibration.....	3-21
3.3.2	Sampling Procedures .....	3-21
3.3.2.1	Preparation of Location.....	3-21
3.3.2.2	Water Level and Total Depth Measurements .....	3-21
3.3.2.3	Monitoring Well/Point Purging.....	3-22
3.3.2.4	Sample Extraction .....	3-22
3.3.3	Onsite Groundwater Parameter Measurement .....	3-23
3.3.3.1	Dissolved Oxygen Measurements .....	3-23
3.3.3.2	pH, Temperature, and Specific Conductance .....	3-24
3.3.3.3	Alkalinity Measurements .....	3-24
3.3.3.4	Nitrate- and Nitrite-Nitrogen Measurements.....	3-24
3.3.3.5	Carbon Dioxide Measurements.....	3-24
3.3.3.6	Sulfate and Sulfide Sulfur Measurements.....	3-25
3.3.3.7	Total Iron, Ferrous Iron, and Ferric Iron Measurements .....	3-25
3.3.3.8	Manganese Measurements.....	3-25
3.3.3.9	Redox Potential.....	3-25
3.4	SAMPLE HANDLING FOR LABORATORY ANALYSIS.....	3-26
3.4.1	Sample Preservation.....	3-26
3.4.2	Sample Container and Labels .....	3-26
3.4.3	Sample Shipment .....	3-27

3.4.4 Chain-of-Custody Control.....	3-27
3.4.5 Sampling Records.....	3-28
3.4.6 Laboratory Analyses.....	3-29
3.5 AQUIFER TESTING.....	3-29
3.5.1 Definitions.....	3-29
3.5.2 Equipment.....	3-30
3.5.3 General Test Methods.....	3-30
3.5.4 Falling Head Test.....	3-31
3.5.5 Rising Head Test.....	3-33
3.5.6 Slug Test Data Analysis.....	3-33
4 REMEDIAL OPTION EVALUATION AND TS REPORT.....	4-1
5 QUALITY ASSURANCE/QUALITY CONTROL.....	5-1
6 REFERENCES.....	6-1
APPENDIX A CONTAINERS, PRESERVATIVES, PACKAGING, AND SHIPPING REQUIREMENTS FOR GROUNDWATER SAMPLES	
APPENDIX B AVAILABLE SOIL AND GROUNDWATER ANALYTICAL RESULTS AND SOIL BORING LOGS	

**TABLES**

	Page
2.1 Monitoring Well Construction Details.....	2-14
2.2 Summary of Groundwater Elevations.....	2-15
2.3 Hydraulic Conductivity Data.....	2-17
2.4 Summary of Free product Thickness.....	2-19
2.5 Comparison of Pure JP-4 With Free product From Monitoring Well 771MW-7.....	2-23
2.6 Groundwater BTEX data.....	2-24
2.7 Quarterly Detects of Volatile (Non-BTEX), Semi-Volatile, and Glycol Compounds....	2-27
2.8 Federal MCLs and State Groundwater Standards for Pumphouse 5 Contaminants.....	2-30
3.1 Analytical Protocol for Groundwater and Soil.....	3-2
4.1 Example EE/CA Report Outline.....	4-2
5.1 QA/QC Sampling Program.....	5-2

## FIGURES

	Page
1.1 Base Location Map .....	1-4
1.2 Base Map With Site Location .....	1-6
1.3 Pumphouse 5 Site Map .....	1-7
1.4 Pumphouse 5 Infrastructure Map .....	1-8
2.1 Physiographic Map of New York State .....	2-2
2.2 Surficial Geology Map .....	2-5
2.3 Stratigraphic Profile of the Mohawk Lowland Section .....	2-6
2.4 Bedrock Topography Map .....	2-7
2.5 Location of Geologic Cross-Sections .....	2-10
2.6 Cross-Section A-A' (West to East) .....	2-11
2.7 Cross-Section A'-B (Southeast to Northwest) .....	2-12
2.8 Cross-Section B-B' (West to East) .....	2-13
2.9 Triangulated Groundwater Elevations in the Surface Aquifer .....	2-16
2.10 BTEX Concentrations in Soil Gas .....	2-20
2.11 Total Petroleum Hydrocarbon Concentrations in Soil Gas .....	2-21
2.12 BTEX Concentrations in Groundwater .....	2-26
2.13 Glycol Concentrations in Groundwater .....	2-29
2.14 Approximate Limits of Anticipated Removal Action Plan .....	2-37
3.1 Cross Section of Geoprobe <sup>®</sup> .....	3-4
3.2 Geologic Boring Log .....	3-6
3.3 Proposed Geoprobe Sampling and/or Monitoring Point Installation Locations .....	3-7
3.4 Monitoring Point Installation Record .....	3-13
3.5 Monitoring Point Development Record .....	3-16
3.6 Groundwater Sampling Record .....	3-19
3.7 Aquifer Test Data Form .....	3-32

## SECTION 1

### INTRODUCTION

This work plan, prepared by Parsons Engineering Science, Inc. (Parsons ES) [formerly Engineering-Science, Inc. (ES)], presents the scope of work required for the collection of data necessary to conduct a treatability study (TS) for remediation of groundwater contaminated with petroleum hydrocarbons at Pumphouse 5 (Building 771), Griffiss Air Force Base (AFB) in Rome, New York. Hydrogeologic and groundwater chemical data necessary to evaluate multiple remedial options will be collected under this program; however, this work plan is primarily oriented toward the collection of hydrogeologic data to be used in support of intrinsic remediation (natural attenuation) for restoration of fuel-hydrocarbon-contaminated groundwater. Other remedial options will be considered in conjunction with intrinsic remediation during the TS, including free product removal; groundwater extraction and treatment (i.e., pump and treat); biosparging; bioslurping; and natural contaminant attenuation (intrinsic remediation) with long-term monitoring.

Data collected during the TS will also be used as input into the Bioplume II groundwater solute transport model code. As part of the TS, the Bioplume II modeling effort has two primary objectives: 1) to predict the future extent and concentration of the dissolved contaminant plume by modeling the effects of advection, dispersion, sorption, and biodegradation; and 2) to provide technical support for selection of the intrinsic remediation option as the best remedial alternative at regulatory negotiations, as appropriate. The TS and the Bioplume II modeling effort for the Pumphouse 5 site will involve completion of several tasks, which are described in the following sections.

This work plan was developed based on discussions among representatives from the Air Force Center for Environmental Excellence (AFCEE) Technology Transfer Division, Griffiss AFB, and Parsons ES at a meeting at the Base on February 9, 1995; on the statement of work (SOW) for this project; and on a review of existing site characterization data. All field work will follow the health and safety procedures presented in the program *Health and Safety Plan for Bioplume II Modeling Initiative* (ES, 1993) and the site-

specific addendum to the program Health and Safety Plan. This work plan was prepared for AFCEE and Griffiss AFB.

## **1.1 SCOPE OF CURRENT WORK PLAN**

The ultimate objective of the work described herein is to provide a TS for remediation of groundwater contamination at Pumphouse 5. However, this project is part of a larger, broad-based initiative being conducted by AFCEE in conjunction with the US Environmental Protection Agency (EPA) and Parsons ES to document the biodegradation and resulting attenuation of fuel hydrocarbons and solvents dissolved in groundwater, and to model this degradation using the Bioplume II numerical groundwater model. For this reason, the work described in this work plan is directed toward the collection of data in support of this initiative. All data required to develop a 30-percent design of an alternate remediation system, should intrinsic remediation not prove to be a viable remedial option at this facility, also will be collected under this program. This work plan describes the site characterization activities to be performed in support of the TS and the Bioplume II modeling effort. Field activities will be performed to determine the extent of residual, free phase, and dissolved contamination at the Pumphouse 5 site. The Pumphouse 5 site includes all areas impacted by contaminated groundwater as a result of fuel releases by USTs and infrastructure (e.g., valve pits and fuel collection drains) associated with Pumphouse 5. Other potential sources or contamination emanating from the tarmac or lateral control pits are not under the scope of this project. Data collected from field activities will be used along with data from previous investigations to complete the characterization of contaminants at the site and for use in the Bioplume II model to predict the future concentrations and extent of contamination.

Site characterization activities in support of the TS include: 1) determination of preferential contaminant migration pathways; 2) soil and groundwater sampling using the Geoprobe<sup>®</sup> apparatus; 3) monitoring point placement; and 4) aquifer testing. The materials and methodologies required for collection of these data are described herein. Existing site-specific data and data collected during the supplemental site characterization activities described in this work plan will be used as input for the Bioplume II model. Where site-specific data are not available, conservative values for the types of aquifer materials present at the site obtained from widely accepted published literature will be used for model input. Sensitivity analyses will be conducted for the parameters which are known to have the greatest influence on the results of Bioplume II modeling, and where possible, the model will be calibrated using historical site data. Upon completion of the

Bioplume II modeling, Parsons ES will provide technical assistance at regulatory negotiations to support the intrinsic remediation option if the results of the modeling indicate that this approach is warranted. If it is shown that intrinsic remediation is not the most appropriate remedial option, Parsons ES will recommend the most appropriate groundwater remedial technology based on available data.

This work plan consists of six sections, including this introduction. Section 2 presents a review of existing site-specific data and a conceptual model for the site. Section 3 describes the proposed sampling strategy and procedures to be used for the collection of additional site characterization data. Section 4 describes the remedial option evaluation procedure and TS report format. Section 5 describes the quality assurance/quality control (QA/QC) measures to be used during this project. Section 6 contains the references used in preparing this document. There are two appendices to this work plan. Appendix A contains a listing of containers, preservatives, packaging, and shipping requirements for groundwater samples. Appendix B contains a summary of existing soil and groundwater analytical data and soil boring logs from previous field investigation work.

## **1.2 BACKGROUND**

Griffiss AFB is located in Oneida County in central New York State. The Base covers approximately 3,900 contiguous acres and is located within the flood plain of the Mohawk River Valley (Figure 1.1). The Base is east of and bordering the city of Rome, approximately 10 miles northwest of the city of Utica, and approximately 2 miles west of the town of Floyd. Syracuse is located approximately 40 miles west of the Base. Predominant forms of land use outside of Griffiss AFB are rural agricultural and forested (northeast of Base), residential or commercial (northwest of Base), and industrial (southwest of Base).

Griffiss AFB became operational on February 1, 1942. The mission of the Base has varied during its time of operation. Griffiss AFB is a US Air Force (USAF) Air Combat Command (ACC) installation. The 416th Wing under the ACC is the host unit of Griffiss AFB. Approximately 4,500 permanent military personnel are assigned to Griffiss AFB, and about 3,000 civilians are employed at the Base. The primary mission of the Wing is the maintenance and implementation of effective aerial refueling operations and provisions of bombardment capabilities on a global scale. The Base was designated by Congress for realignment in October 1993, which is scheduled for completion on September 30, 1995.

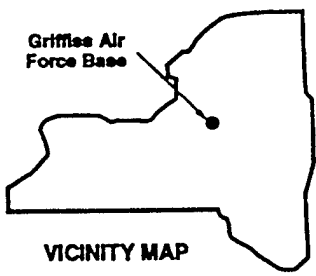
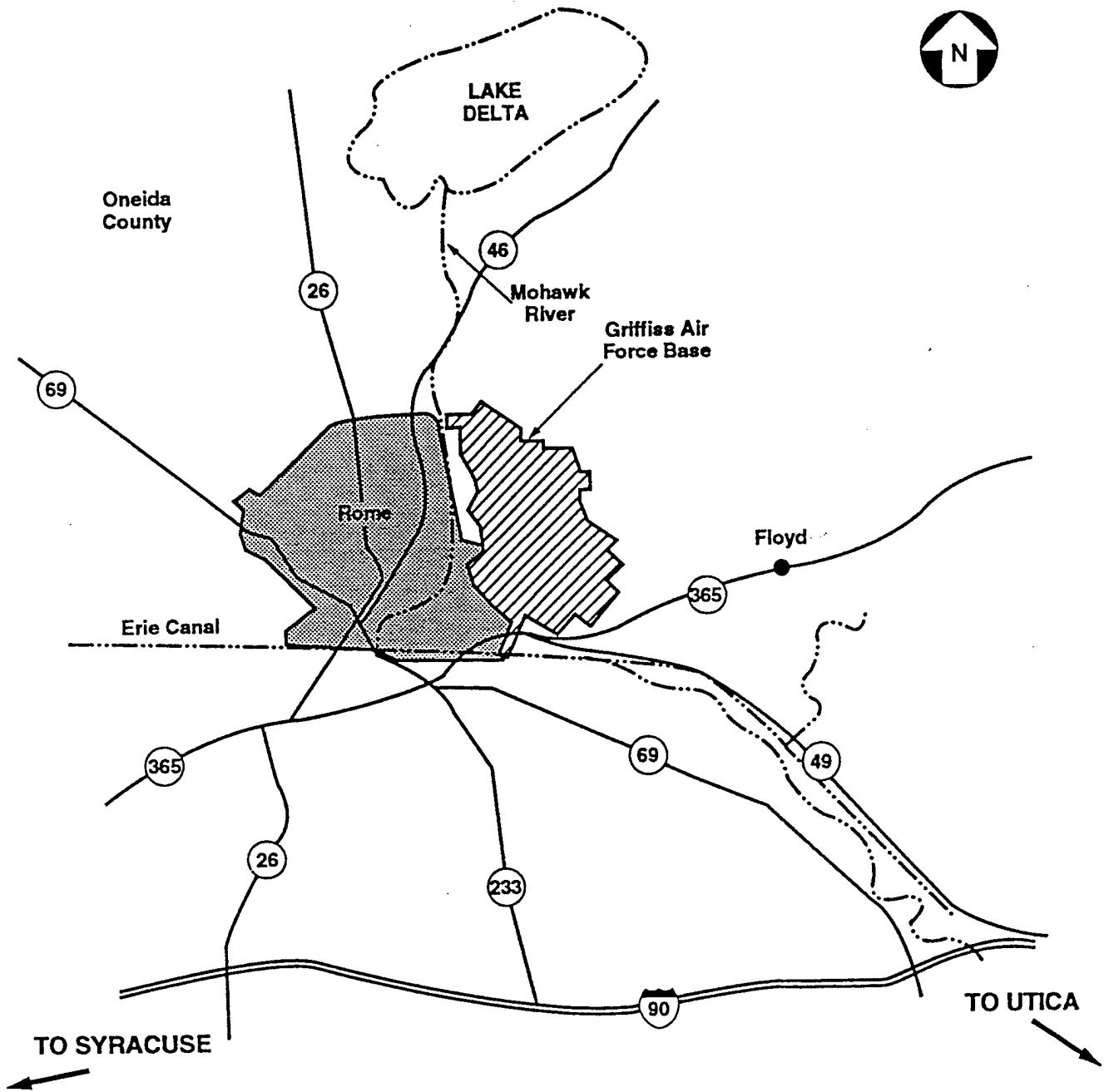

**FIGURE 1.1**

**BASE LOCATION MAP**

Pumphouse 5  
 Intrinsic Remediation TS  
 Griffiss AFB, New York

**PARSONS ENGINEERING SCIENCE, INC.**  
 Denver, Colorado

Source: Law, 1994.

NOT TO SCALE

Pumphouse 5 (Building 771), hereinafter referred to as the site, is located approximately 100 feet northwest of Parking Apron 1 in a relatively flat, grass covered area that slopes toward a drainage ditch to the northwest (Figures 1.2 and 1.3). Pumphouse 5 (Building 771) serves as a fuel storage and transfer station for aircraft refueling operations on Parking Apron 1. Four 50,000-gallon underground storage tanks (USTs) are used to store JP-4 jet fuel. Two valve pits and a 2,000-gallon collection tank are located on the northwest side of Pumphouse 5 (Figure 1.4). Pumphouse 5 increases pressures in the piping system to facilitate fuel distribution through a fuel/defueling system that parallels the northwest edge of Parking Apron 1 and leads to lateral control pits (LCPs). The LCPs control fuel flow through the pipe under the apron to the hydrant outlet within the parking apron.

Groundwater and soil are contaminated with JP-4 jet fuel at the Pumphouse 5 site to an undetermined extent. Previous work has been done at the site by UNC Geotech (1990) and by Tracer Research Corporation (TRC) (TRC, 1991b) to attempt to define the limits of free product contamination. In addition, leak-detection investigations were conducted by TRC (TRC, 1991a) on the USTs and main hydrant system piping along the apron.

Spill reports on file in the Environmental Management Flight office indicate that three large spills have occurred in the vicinity of Pumphouse 5 since 1977. On March 4, 1977, a Class III JP-4 spill occurred when fuel was released due to a KC-135 aircraft fire (Griffiss AFB, 1977). Griffiss AFB fire prevention personnel indicated the fuel released during this fire was washed into the open trench gate in the center of the apron and was discharged off site; these personnel further indicated that the spilled fuel did not superficially reach Pumphouse 5 during the spill event [Law Environmental, Inc. (Law, 1993)]. On June 26, 1989, samples collected from monitoring wells installed at the site indicated free-phase fuel product at Pumphouse 5 (Griffiss AFB, 1989). The occurrence was reported to the New York State Department of Environmental Conservation (NYSDEC) and was assigned spill number 8903144 for tracking purposes. The site subsequently was considered an open spill site. On February 8, 1991, a Class III JP-4 spill occurred between the fillstand and Pumphouse 5, and was cleaned up with sorbent material (Griffiss AFB, 1991). It was reported to NYSDEC and was assigned NYSDEC spill number 9012023.

As a result of registered spill number 8903144, a soil gas survey investigation was conducted by Tracer Research Corporation for UNC Geotech (1990). Ninety soil gas samples were collected and analyzed in March 1990, for benzene, toluene, ethylbenzene,

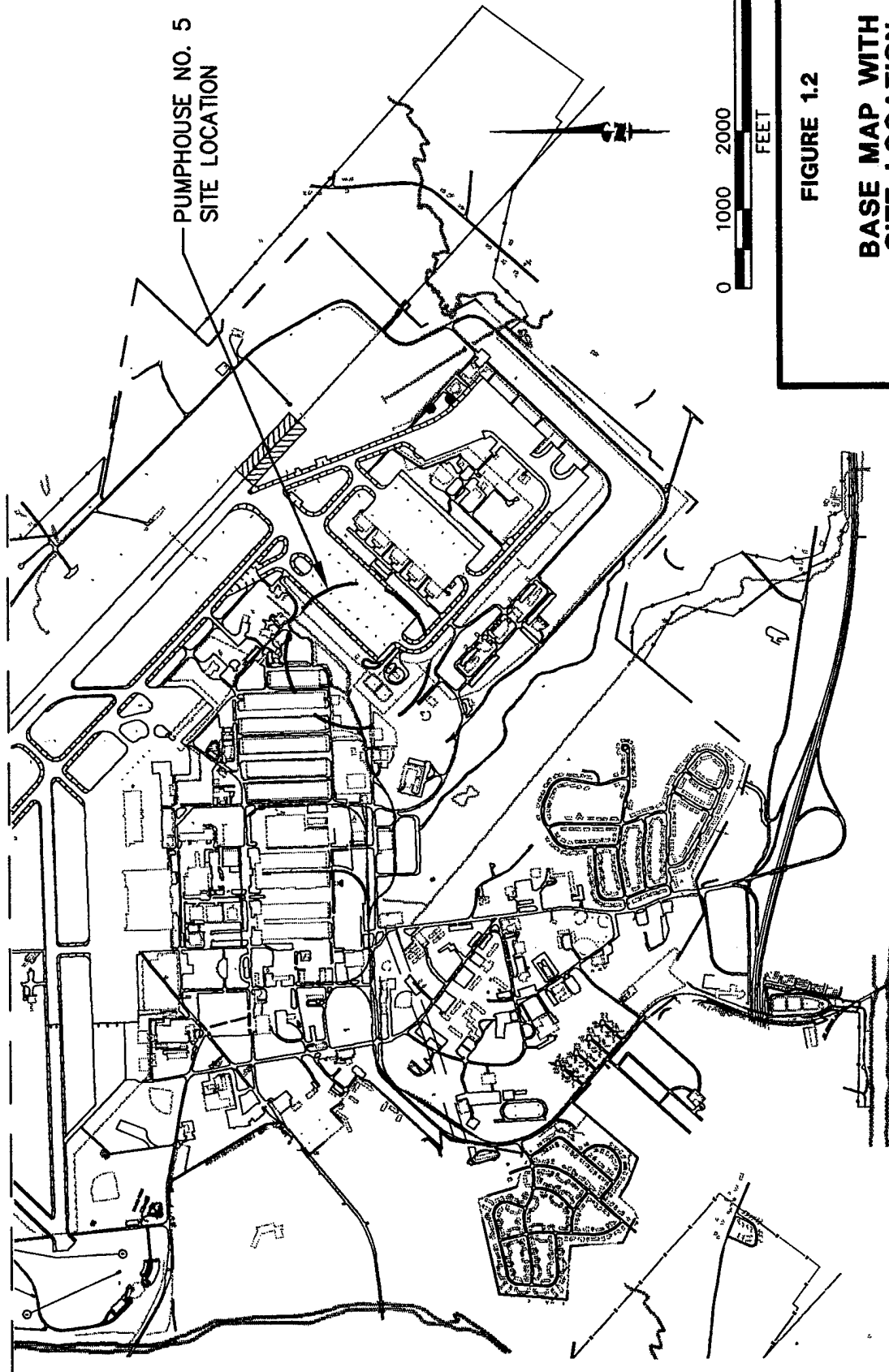

PUMPHOUSE NO. 5  
SITE LOCATION



FIGURE 1.2

**BASE MAP WITH  
SITE LOCATION**  
(Southern Half of Base Shown)

Pumphouse No. 5  
Intrinsic Remediation TS  
Griffiss AFB, New York



**PARSONS  
ENGINEERING SCIENCE, INC.**

Denver, Colorado

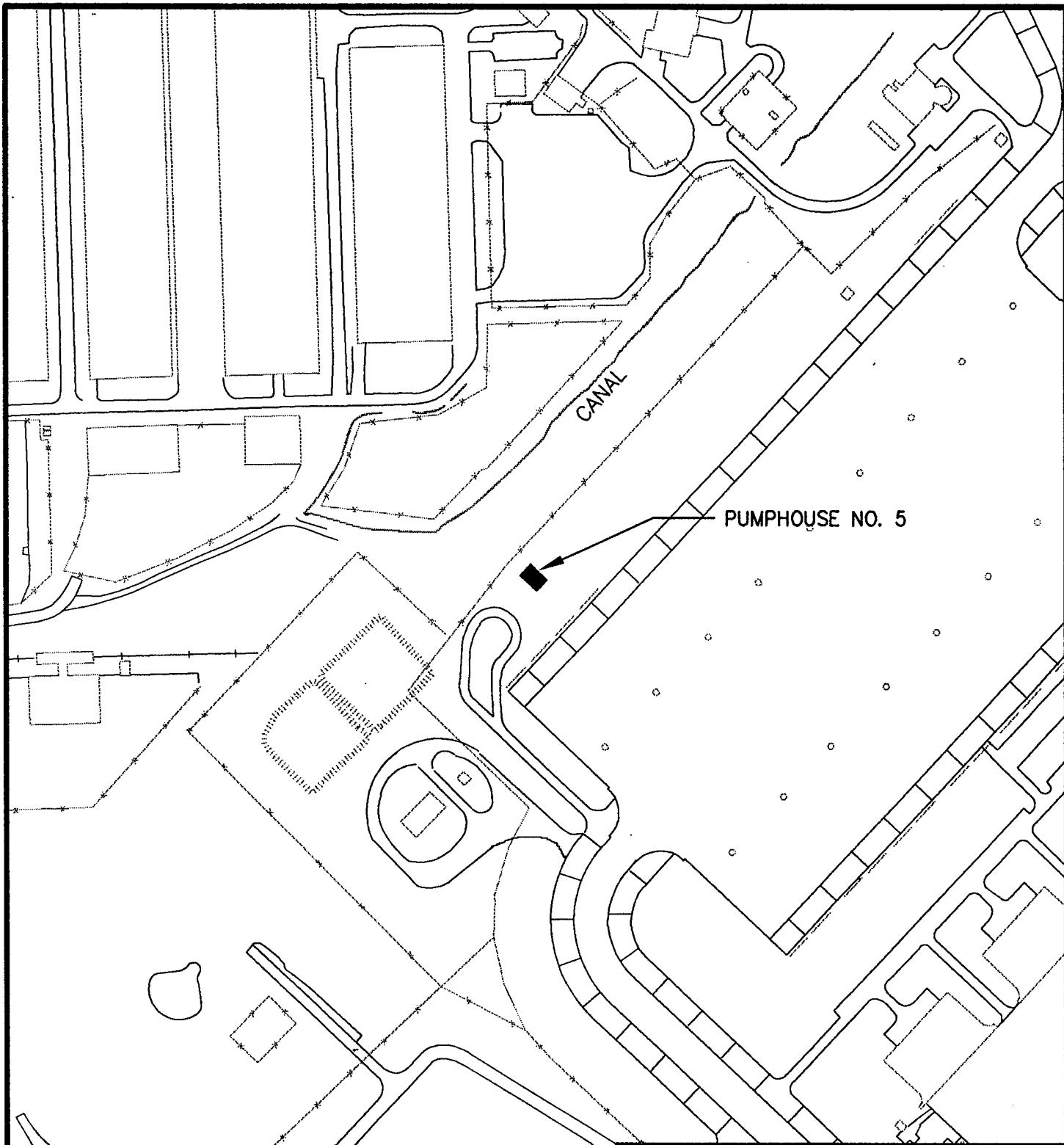

\* — \* FENCE



**FIGURE 1.3**

**PUMPHOUSE 5  
VICINITY MAP**

Pumphouse 5  
Intrinsic Remediation TS  
Griffiss AFB, New York

**PARSONS  
ENGINEERING SCIENCE, INC.**

Denver, Colorado



and xylene (BTEX) and total hydrocarbons indicated that total hydrocarbons and fuel-related contamination was evident at the site. Parratt-Wolff, Inc. (1989) under contract to Griffiss AFB, installed three monitoring wells (771MW-1, -2, and -3) in June 1989 to supplement the soil gas survey results. Four to 5 feet of free-phase fuel product was detected at the site in monitoring wells 771MW-1 and 771MW-3 (Figure 1.4). Additionally, a 0.1-foot-thick free product layer was encountered in monitoring well 771MW-1 on June 29, 1989.

Leak detection investigations for the four 50,000-gallon USTs and the 21,000-foot main hydrant system piping along Parking Apron No.1 were conducted by TRC (1991a) in October and November 1991. These leak-detection surveys consisted of inoculating the line with a volatile tracer compound, and then examining the surrounding area soil gas for traces of it. No leaks associated with the underground facilities were found. The soil gas survey revealed low constituent levels in the parking apron. This survey confirmed the suspected areas of contamination identified earlier by UNC Geotech.

No leak-detection investigations were conducted on the 10-inch transfer fuel line of the piping associated with the valve pit, drain pit, or collection tank (Figure 1.4). Drawings and telephone interviews with Base personnel indicated that the 10-inch transfer fuel line southwest of Building 771 has been relocated on one or more occasions. It is not known whether the pipeline was removed or abandoned before installing the newer line(s).

Law contracted with Parratt-Wolff, Inc. (1992) in December 1991 to install six additional monitoring wells (771MW-4 to 771MW-9) at the site. Free product thicknesses were measured in the wells that contained free-phase fuel (771MW-1, 771MW-3, 771MW-4, and 771MW-7). Thickness measurements indicated 0.01 foot and 5.80 feet in wells 771MW-4 and 771MW-7, respectively.

As a portion of the Base-Wide Quarterly Sampling Project at Griffiss AFB, Law sampled wells 771MW-2, -4, -5, -6, -7, -8, and -9 on four occasions, from the fourth quarter of 1992 through the third quarter of 1993. The sampling exercises included analysis of the groundwater samples for volatile organic compounds (VOCs), semivolatile organic compounds (SVOCs), pesticides/polychlorinated biphenyls (PCBs), total glycols, total metals, and cyanide. Product thickness was measured in May 1992 in wells 771MW-1, -3, -4, and -7. Thicknesses measured were 0.25 feet, 4.10 feet, 0.00 feet, and 3.06 feet, respectively (Parratt-Wolff, Inc., 1992).

Drawings indicated that the 2,000-gallon fuel collection tank was relocated to the northwest corner of Pumphouse 5. Fuel is pumped from the tank on a regular basis when the water and fuel reaches a certain level. Griffiss AFB personnel reported that the tank had occasionally been overfilled in the past, resulting in overflows and spills to the surface and subsurface (Law, 1994). In July 1994, a leak associated with the 2,000-gallon fuel collection tank was discovered in the pipe that runs from the pumphouse floor drain and fuel filter drain to the collection tank. The leak was attributed to a broken pipe fitting leading from the filters to the collection tank. When the piping was removed, soils excavated with the pipe were noticeably contaminated with fuel. The drain pipe has since been disconnected from the building, and the pumphouse floor drains have been filled with concrete. Base personnel indicated that July 19, 1993, was the last time fuel was pumped, and that the tank is no longer in use.

In February 1993, a flexible axial peristaltic (FAP) pump petroleum skimming system was installed to draw down free product in each of the wells where free product was observed. The system was in operation for approximately 6 months to recover free product from the groundwater. After 6 months of operation, the FAP in conjunction with weekly hand bailing removed between 25 and 50 gallons of free product.

The valve pits located northwest of the pumphouse (Figure 1.4) have released fuel contamination in response to precipitation or snowmelt filling the valve pit and clogging the valve system (Law, 1995). The valve pits are used for isolation or diversion valves required for UST operation or for future expansion of fuel storage operations. Seasonally high groundwater elevations may also have pushed floating product from the surrounding formation into the pits. The valve pits are constructed of crushed-stone bottoms, and are a preferential route into the subsurface for spilled fuel. After Base personnel discovered a layer of fuel in the valve pit during FAP monitoring, approximately 300 gallons of groundwater and fuel were pumped from the 4-foot by 4-foot valve pit west of well 771MW-7 in April 1993. Fuels Management at Griffiss AFB has periodically recovered product in the valve pit using absorbent cloths. Further investigation may be necessary to isolate potential leakage in the valve pit due to valve failure or pipeline leakage.

## SECTION 2

### DATA REVIEW AND CONCEPTUAL MODEL DEVELOPMENT

Site-specific data were reviewed and used to develop a conceptual model for groundwater flow and contaminant transport at Pumphouse 5. This conceptual model guided the development of sampling locations and analytical data requirements needed to support the Bioplume II modeling effort and to evaluate potential remediation technologies, including intrinsic remediation. Section 2.1 presents a synopsis of available site data. Section 2.2 presents the preliminary conceptual groundwater flow and contaminant transport model that was developed based on these data.

#### 2.1 DATA REVIEW

The following sections are based upon review of data from the following sources:

- Final Summary Report, Quarterly Groundwater Sampling at Griffiss AFB (Law, 1994), and
- Final Engineering Evaluation/Cost Analysis Report for Pumphouse 5 (Law, 1995)

##### 2.1.1 Topography, Surface Hydrology, and Climate

Griffiss AFB is located adjacent to the flood plain of the Mohawk Valley, which is an east-west trending lowland underlain by sedimentary rocks. The floodplain of the Mohawk River, which is 0 to 2 miles wide, extends across the Mohawk Section, which is part of the Appalachian Plateaus Physiographic Province (Fenneman, 1938) (Figure 2.1). The floodplain reaches a maximum elevation of approximately 450 feet above mean sea level (msl) and is bounded by river-terraced slopes reaching 700 feet above msl. Land surface elevations in the vicinity of Griffiss AFB are relatively flat and range from 460 to 525 feet msl, suggesting that the Base lies outside of the Mohawk flood plain. There are moderate variations in elevation at the Base, except for a plateau to the northeast that reaches 1,300 feet msl.

The Mohawk River is located immediately west of Griffiss AFB and is the largest flowing water body near the Base. The Mohawk River originates in Lewis County, New York (to the north), and from Griffiss AFB, flows 153 miles eastward along the Mohawk

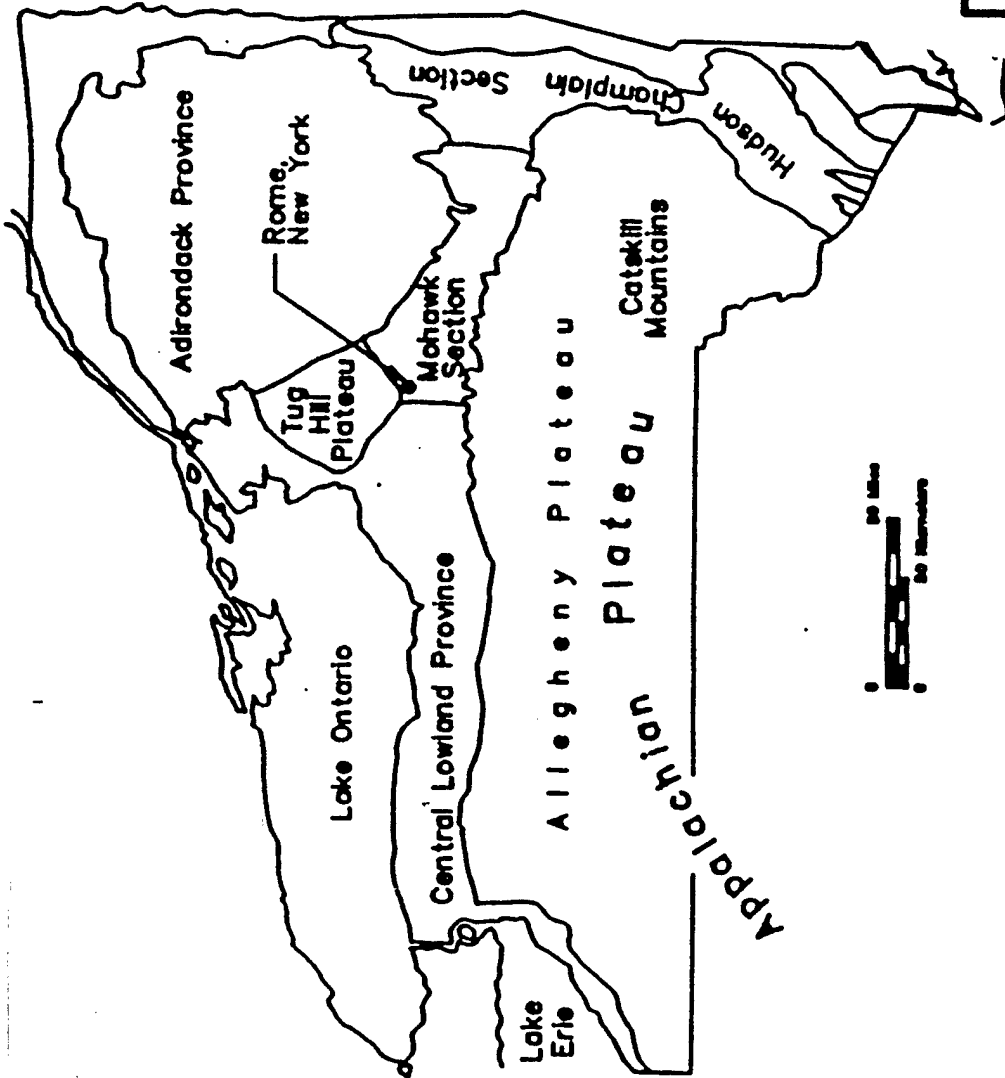

FIGURE 2.1

**PHYSIOGRAPHIC MAP OF  
NEW YORK STATE**

Pumphouse 5  
Intrinsic Remediation TS  
Griffiss AFB, New York



**PARSONS  
ENGINEERING SCIENCE, INC.**  
Denver, Colorado

**SOURCE :**  
**FIGURE 1.1 of the GEOLOGY of NEW YORK,**  
**EDUCATIONAL LEAFLET No. 28 NEW YORK STATE MUSEUM/GEOLOGICAL SURVEY 1991**

Section to eventually join the Hudson River. Important tributaries to the Mohawk River include West Canada Creek, East Canada Creek, Threemile Creek, Sixmile Creek, Nineteen Mile Creek, Oriskany Creek, and Sauquoit Creek. Surface water drainage from Griffiss AFB flows into Threemile Creek, Sixmile Creek and the Mohawk River by direct runoff, runoff into artificial and natural drainage features that eventually discharges to these water bodies, and through the Base stormwater discharge system. Threemile Creek originates in the south-central portion of the Base and flows southeast through the Base before discharging into the New York State Barge Canal. Sixmile Creek enters the Base in the north-northeast corner and flows southeast to exit the eastern border of the Base before discharging into the New York State Barge Canal. Surface water and stormwater from the vicinity of Pumphouse 5 is reported to flow toward Sixmile Creek, the closest reach of which is approximately 1,800 feet to the east. The closest reach Threemile Creek is approximately 1,500 feet to the southwest. There is a drainage ditch 250 feet northwest of the site; however, insufficient data exist to document if portions of stormwater runoff from Pumphouse 5 flow toward the ditch.

Captured stormwater flow in the southwestern portion of the Base (military housing area), which may include waters from the Pumphouse 5 area, is eventually channeled to the city of Rome storm sewer system south of the Base. Sixmile Creek receives surface water and stormwater drainage from the areas east of the flight line, most of the flight-line area, the nosedock areas and many buildings and roadways west of the flight line. Surface and stormwater from the west and northwest portions of the Base discharge directly into the Mohawk River.

Griffiss AFB experiences a continental climate characterized by warm, humid, moderately wet summers and cold winters with moderately heavy snowfalls. Average winter temperatures from mid-December to mid-March are 20 degrees Fahrenheit (°F). Spring, summer, and fall temperatures range from 31°F to 81°F. The mean annual precipitation is 45.6 inches and the mean annual snowfall is 107 inches. Evapotranspiration rates are approximately 22 inches per year.

## **2.1.2 Overview of Geology and Hydrogeology**

### **2.1.2.1 Regional Geology and Hydrogeology**

The entire surface geology of the Mohawk River Section was shaped by glacial advances and retreats that occurred approximately 20,000 to 30,000 years ago. Large quantities of soil and rock were transported with the glaciers and eventually deposited as a

blanket of till (ground moraine) beneath the advancing ice mass. As a result of two glacial lobes that repeatedly moved in and out of the Rome and Griffiss AFB vicinity, the area was a depositional center for a variety of glacial sediments and landforms. The unconsolidated sediments that make up the surface aquifer consist of Pleistocene glacial, fluvial and deltaic deposits (Figure 2.2).

Bedrock in the Mohawk Section consists of shale, sandstone and limestone deposited during Middle and Late Ordovician time (476 to 438 million years ago). The four upper bedrock units in the Mohawk Section include the Black River Group (deepest), the Trenton Group, Utica Shale, and the Lorraine Group (shallowest) (Fisher *et al.*, 1970). Figure 2.3 illustrates this bedrock stratigraphy. The limestones of the Middle Ordovician-aged Black River Group were deposited in previous tropical climates, and are fossiliferous with very little clay and silt. Some layers of bentonite are present as a result of volcanic ash deposited from the atmosphere. The Middle Ordovician-aged Trenton Group also is mostly limestone, with the exception that thin layers of shale are present. Above the Trenton Group lie hundreds of feet of Late Middle Ordovician to Late Ordovician-age Utica Shale. In the Rome area, the Utica Shale has been described as a black and gray carbonaceous shale containing calcareous argillites (Halber *et al.*, 1962).

Situated above the Utica Shale is zone of coarser material (deposited in shallowing seas) defined as the Lorraine Group. Formations of the Lorraine Group increase in coarseness upward and westward, and vary from shale and siltstone (Frankfort Formation), to siltstone and shale (Whetstone Gulf Formation), to sandstone, siltstone and shale (Pulaski Formation), and to sandstone with minor amounts of shale (Oswego Formation). In the vicinity of Rome and Griffiss AFB, the Frankfort and Pulaski Formations have been described as gray sandy shale with thin beds of dolomite and calcareous sandstone (Halberg *et al.*, 1962).

Other unconsolidated deposits present in the Griffiss AFB area include lodgement and ablation tills. Lodgement till, originally deposited as ground moraine, is tough and compact and characterized by low hydraulic conductivities. Ablation tills, deposited during glacial melting, are more permeable than lodgement till, and are loosely consolidated with a larger percentage of sand and gravel. Ablation tills can support limited groundwater pumping (Reynolds, 1990).

The depth to the underlying bedrock at Griffiss AFB (Utica Shale) varies across the Base, gradually increasing to the south-southwest (Figure 2.4). The Lorraine group is shallowest in the central portion of the Base, at approximately 25 to 30 feet below ground

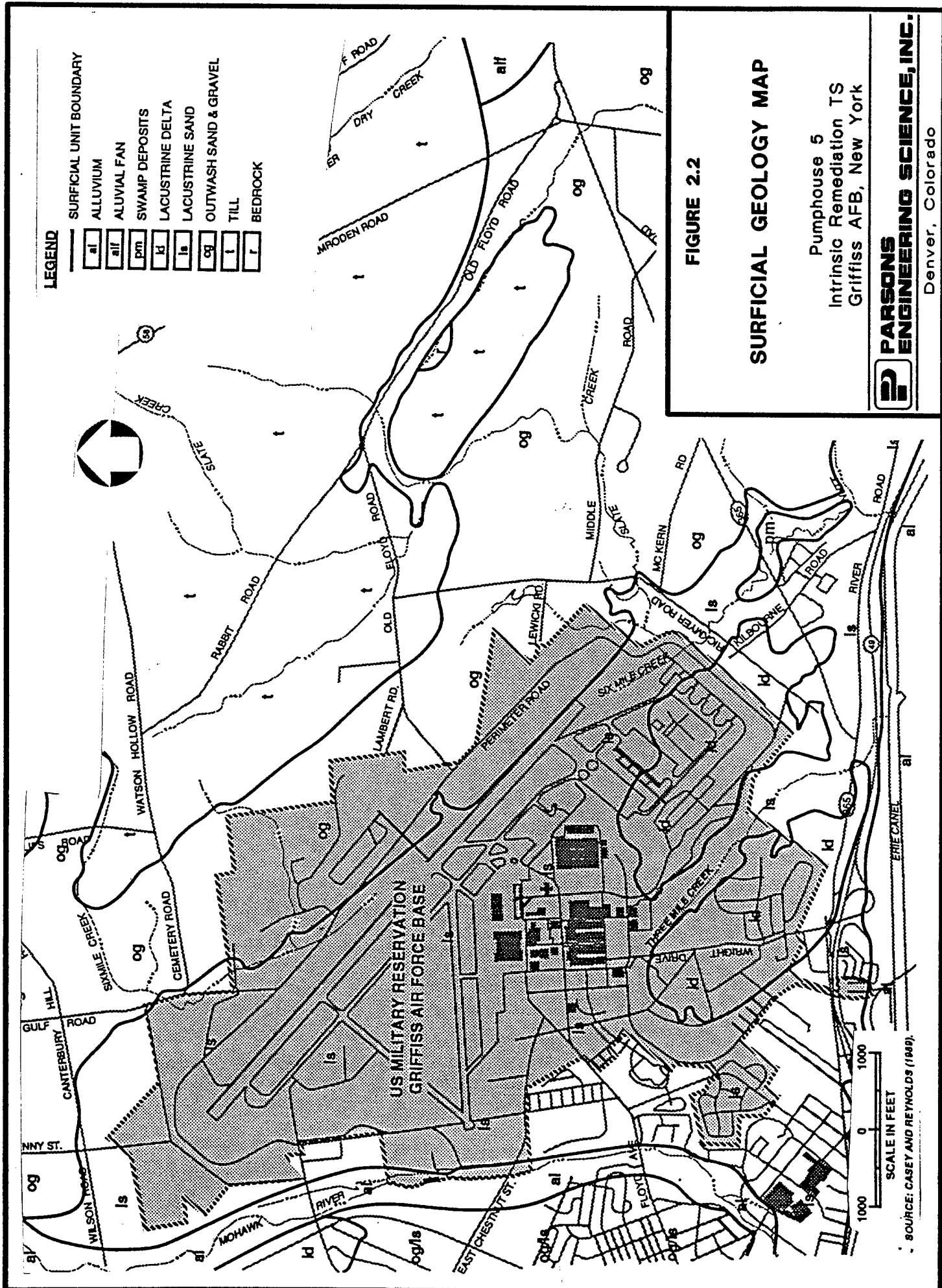

**LEGEND**

- SURFICIAL UNIT BOUNDARY
- ALLUVIUM
- ALUVIAL FAN
- SWAMP DEPOSITS
- LACUSTRINE DELTA
- LACUSTRINE SAND
- OUTWASH SAND & GRAVEL
- TILL
- BEDROCK

**FIGURE 2.2**

**SURFICIAL GEOLOGY MAP**

Pumphouse 5  
 Intrinsic Remediation TS  
 Griffiss AFB, New York



**PARSONS**  
**ENGINEERING SCIENCE, INC.**

Denver, Colorado

SCALE IN FEET  
 0 1000 1000  
 SOURCE: CASEY AND REYNOLDS (1949).

UNIT/GROUP	FORMATION	AGE	DEPOSITIONAL ENVIRONMENT	FOSSIL ASSEMBLAGE	STRATIGRAPHIC THICKNESS
Lorraine Group	Owego Sandstone coarser grained sandstone	Late Ordovician	near shore & beach	few trace fossils	NR
	Pulecki Formation fine-grained sandstone		shallow water	many fossils of bottom-dwelling clams & brachiopods	NR
	Whetstone Gulf & Frankfort Formations siltstone & shale		moderately deep water	graptolites & trilobites	NR
Utice Shale black shale; thickest in east-central New York, thins to west		Late Middle Ordovician to Late Ordovician	deep basin	graptolites & trilobites	275 m near Herdimer
Trenton Group thin black shale alternating with thicker layers (5 - 30 cm) of limestone		Middle Ordovician	several underwater environments, each with its own creatures: lagoons, barrier shoals, shallow shelf, deep shelf, slope between shelf & basin	many fossils, including <u>Prezopora</u> & other bryozoans, corals, attached echinoderms, brachiopods, & trilobites	160 m near Watertown 130 m at Trenton Falls 4.5 m at Canajoharie Creek
	Black River Group	Middle Ordovician	shallow marine carbonate mud on level sea floor	many fossils	90 m in places
Black River Group	Watertown Limestone	Middle Ordovician	variety of mud flats between low & high tide	many fossils	abundance of coral <u>Tetradium</u>
	Lowville Formation mudcracked lime mudstone in thin to thick layers		underwater carbonate sand		
	fossil hash limestone		mud & sand flats just above high tide		
	Pamella Formation dolostone & sandstone				

\* Found on south shore of Lake Ontario.  
NR - Not reported in literature source.

FIGURE 2.3

STRATIGRAPHIC PROFILE  
OF THE  
MOHAWK LOWLAND SECTION

Pumphouse No. 5  
Griffiss Air Force Base  
Rome, New York



PARSONS  
ENGINEERING SCIENCE, INC.

Denver, Colorado

Source: Law, 1994.

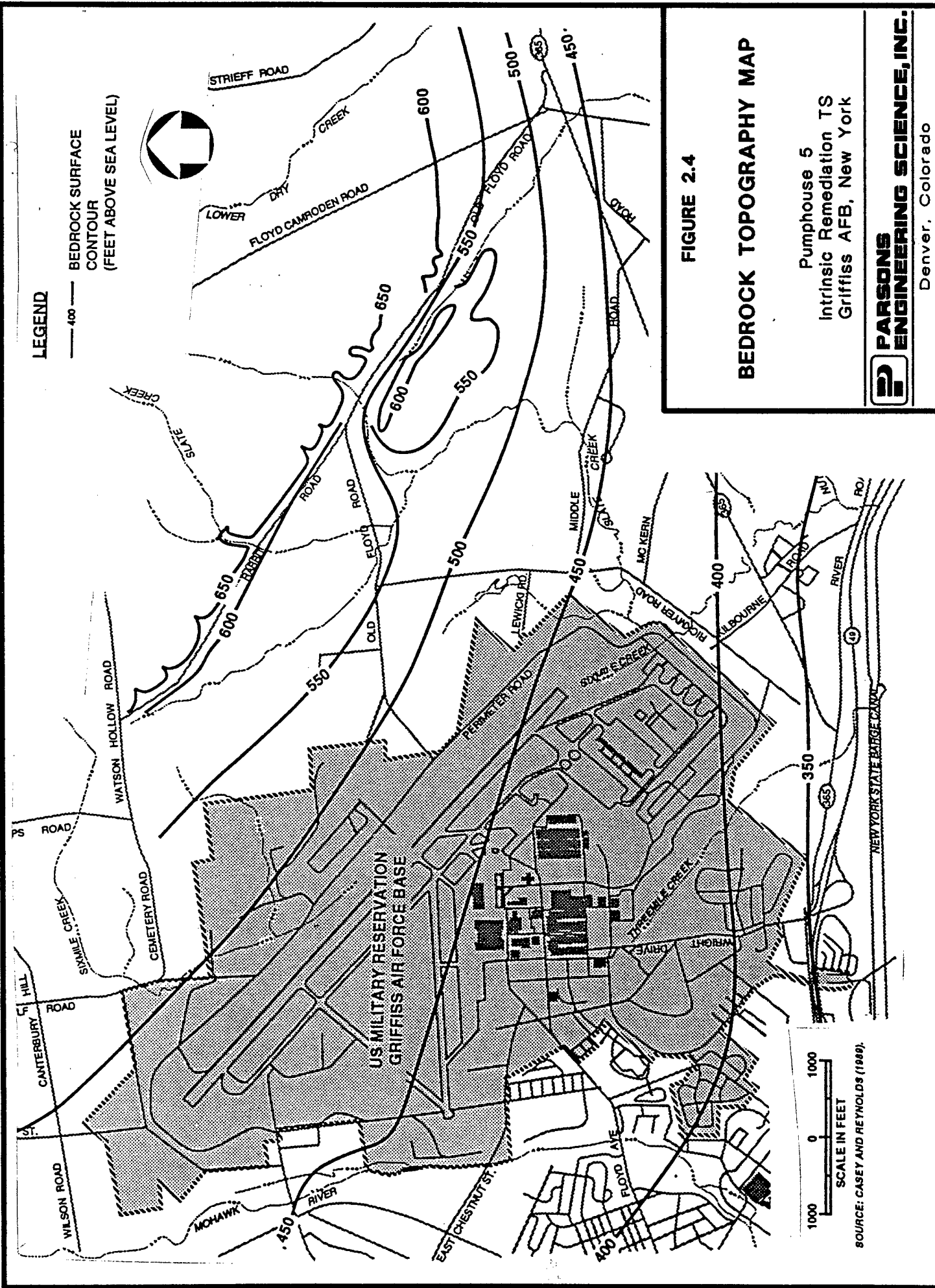

**LEGEND**

— 400 —  
 BEDROCK SURFACE  
 CONTOUR  
 (FEET ABOVE SEA LEVEL)



**FIGURE 2.4**

**BEDROCK TOPOGRAPHY MAP**

Pumphouse 5  
 Intrinsic Remediation TS  
 Griffiss AFB, New York



**PARSONS  
 ENGINEERING SCIENCE, INC.**

Denver, Colorado

1000 0 1000  
 SCALE IN FEET

SOURCE: CASEY AND REYNOLDS (1989).

surface (bgs). The depth to bedrock in the northern part of the Base varies from 12 to 50 feet bgs, and in the southern part of the Base bedrock is as deep as 130 feet bgs.

Groundwater recharge in the Griffiss AFB area are obtained from the Mohawk River and Mohawk River tributaries, which include Oriskany, Sauguoit, and West Canada Creeks. In times of low precipitation, groundwater discharges to the Mohawk River and Mohawk River tributaries, with the effect of maintaining the low-water flow. Unconsolidated deposits that may represent significant aquifers include outwash sand and gravel deposited in major tributary valleys leading to the Mohawk River Valley, ice-contact deposits of kames and kame moraines, and coarse-grained recent alluvium within major stream valleys.

Groundwater storage in unconsolidated zones of the Mohawk River Valley is governed by stratigraphy and surface stream channeling. Just east of Griffiss AFB to the town of Floyd (approximately 2 miles), the sand and gravel deposits of the surface aquifer contain large quantities of water because the stratified deposits are thick, are saturated for much of their thickness, and in at least one area are crossed by Ninemile Creek (a potential recharge source). Other potential groundwater reservoirs over the Mohawk River Valley area include sand and gravel deposits underlying an extensive plain between Rome and a reservoir to the north (Delta Reservoir), and terrace sand and gravel deposits in the Ninemile Creek valley (Casey and Reynolds, 1989). The unconsolidated deposits of the Ninemile soil range in thickness from 30 feet (near Holland Patten) to 140 feet just east of Griffiss AFB. However, the present Ninemile Creek has trenched the surface soils (deltaic deposits) to bedrock on its southern length, which has drained a majority of the groundwater in this area. Well production capacities over the Mohawk River Valley in fine- to coarse grained glacio-fluvial, deltaic, lacustrine, or alluvial deposits vary from 2 to 290 gallons per minute (gpm) of water (Halberg *et al.*, 1962). The general direction of groundwater flow across the Base is in a southwesterly direction (UNC Geotech, 1991).

Groundwater also is contained in bedrock through secondary openings along joints, bedding planes, and faults. Bedrock in the Utica Shale formation has yielded groundwater at average rates of 7.5 gpm at an average depth of 127 feet bgs. Bedrock in the various formations of the Lorraine Group average 5 gpm at an average depth of 114 feet bgs.

#### **2.1.2.2 Site Geology and Hydrogeology at Pumphouse 5**

Sediments near Pumphouse 5 and the central portion of the Base consist of silty sands underlain by glacial till (found mostly east- and west-central) with the remainder of the

basal unit consisting of gravels. The southern portion of the Base is primarily underlain by well-sorted sands, with some gravelly-sands, silty gravels, silts and fine sands. A geologic cross-section location map and three cross-sections that were generated by UNC Geotech (1991) illustrate the thickness and distribution of sediments in the mid- and lower-half of Griffiss AFB (Figures 2.5 through 2.8). These cross-sections depict a general trend of sediments coarsening in texture from south to north.

On the basis of boring log data recorded by Parratt-Wolff, Inc. [under contract by Law to install monitoring wells 771MW-4 to 771MW-9] in December 1991, the soils around Pumphouse 5 appear to consist of fine- to medium-grained sands, fine- to medium-gravels, silts, and traces of clay. A summary of monitoring well construction details is presented in Table 2.1. Vadose soils consist of dense brown, grayish brown, or reddish fine- to medium-grained silty sands, coarse gravel, and rock fragments. In the saturated zone (approximately 10 to 15 feet bgs), fine- to medium-grained sands continue to dominate, with soil colors varying between dark-gray, dark brown, brown, yellow, and orange. Gray colored soils may suggest anaerobic soil zones. Clayey soils were observed from between 12 and 19 feet bgs at boreholes 771MW-4, 771MW-5, and 771MW-7. Stringers of sandy-clay are not believed to create locally confined conditions at the site as a result of predominantly sandy soils and a significant saturated thickness. Cross-section B-A' (Figure 2.7) and available boring logs (Appendix B) suggest that the depth to bedrock (Utica Shale) at the site may range from 25 to 50 feet bgs. Soilbore holes were extended to 25 feet bgs at 771MW-4, 771MW-6, 771MW-7, 771MW-8, and 771MW-9 without contacting the bedrock.

Groundwater elevations in the Pumphouse No. 5 area were measured quarterly from November 1992 through September 1993 as part of Griffiss AFB's objective to evaluate seasonal trends in groundwater flow. Table 2.2 contains available groundwater elevation data. Figure 2.9 shows the measured groundwater elevations from each quarter. Flow direction is counter-regional to the southwesterly groundwater flow pattern across the Base. Groundwater flow direction north of monitoring well 771MW-7 and Pumphouse 5 is to the north and northwest regardless of season. This northerly flow may eventually discharge to a drainage ditch located approximately 250 feet northwest of the pumphouse. Beneath the pumphouse and near monitoring well 771MW-6, the dominant groundwater flow direction in the summer and fall is north, with some localized western flow near the pumphouse in the fall. East of the pumphouse, groundwater flow direction is erratic and switches from westerly flow in the fall to southeasterly flow in the summer. Buildings,

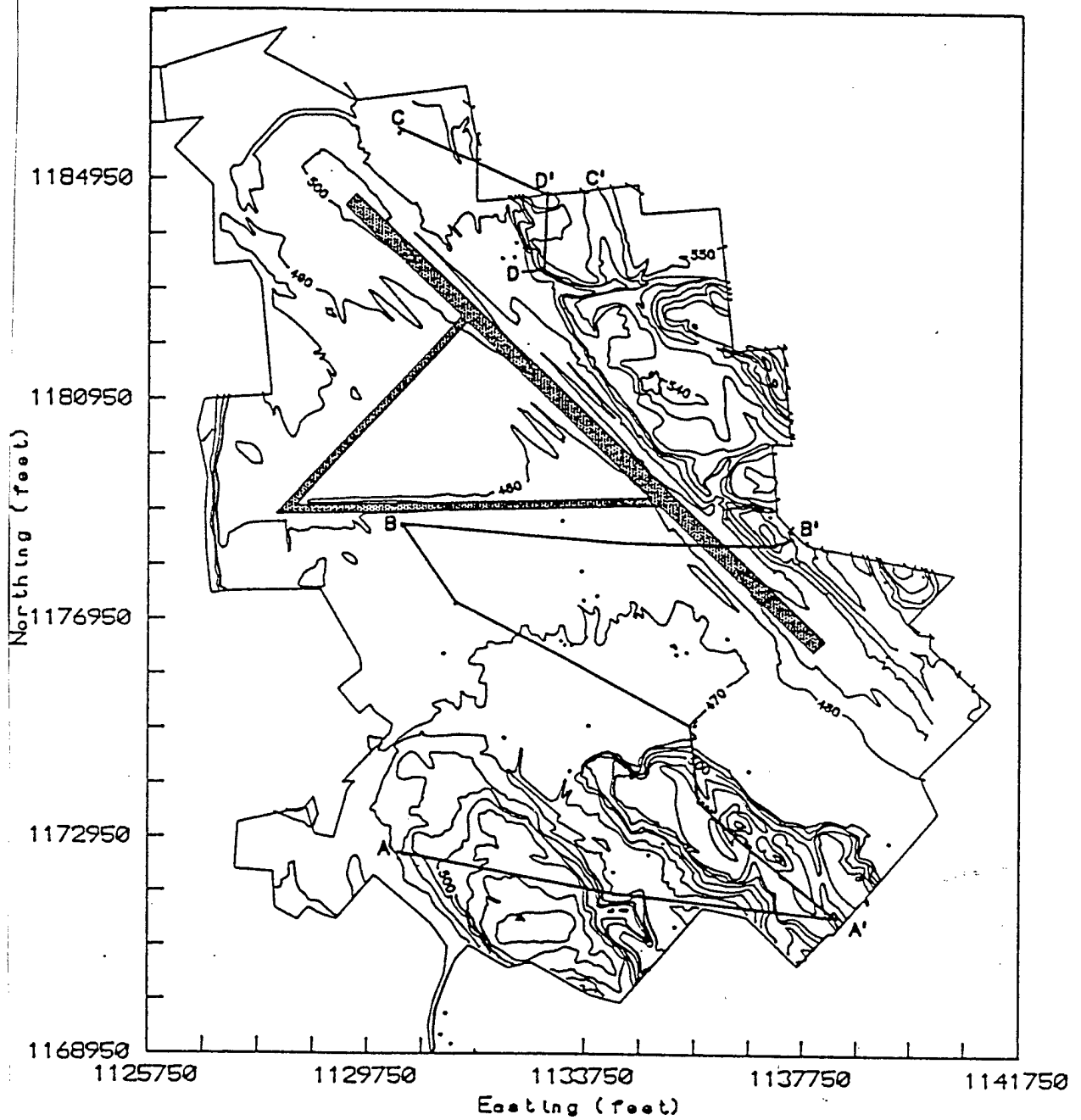

Geologic Cross-section locations for the GAFB Hydrogeology Study. Points are well locations.

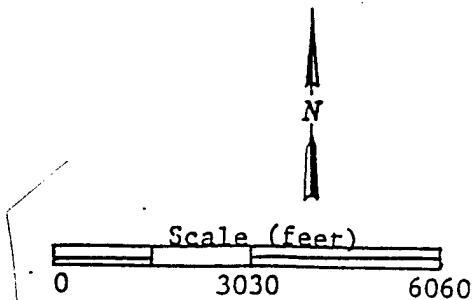

**FIGURE 2.5**  
**LOCATION OF**  
**GEOLOGIC**  
**CROSS-SECTIONS**

Pumphouse 5  
Intrinsic Remediation TS  
Griffiss AFB, New York

**PARSONS**  
**ENGINEERING SCIENCE, INC.**

Denver, Colorado

Source: UNC Geotech, 1991.

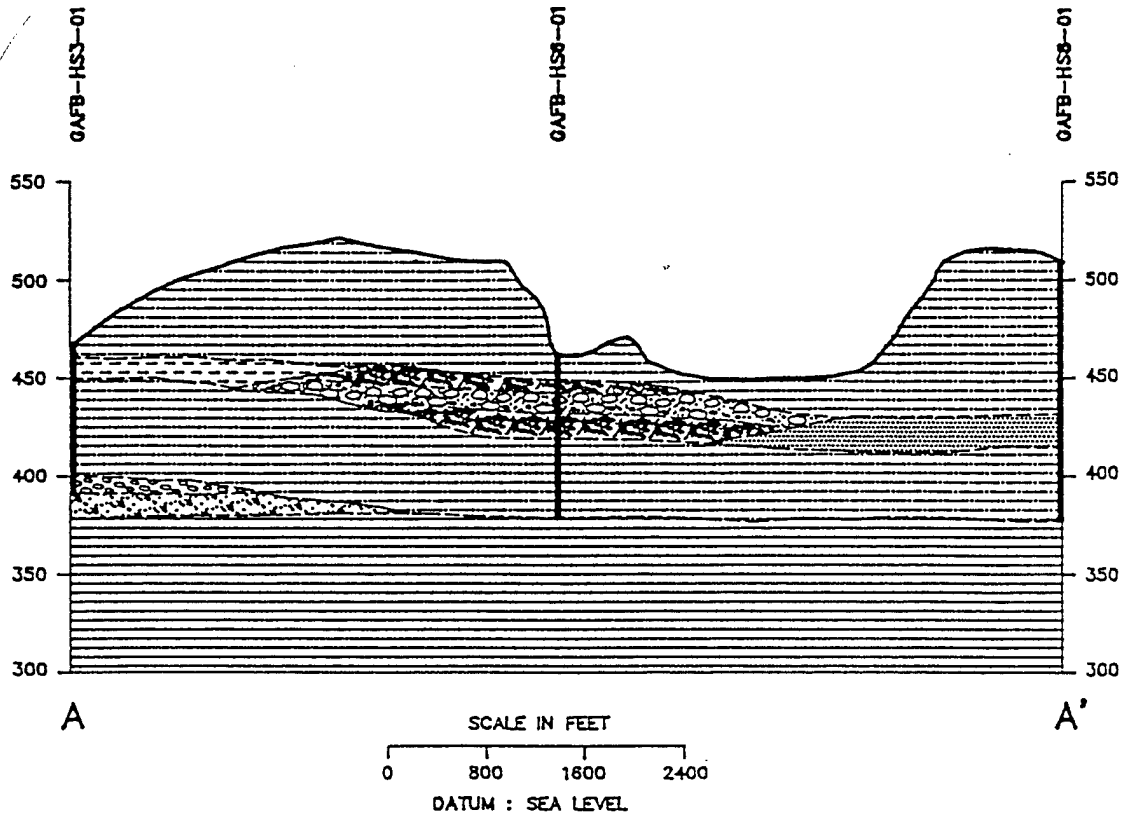

EXPLANATION









- |   |   |   |  |
|---|---|---|--|
|  | ML: INORGANIC SILTS AND VERY FINE SANDS, ROCK FLOUR, SILTY OR CLAYEY FINE SANDS WITH SLIGHT PLASTICITY. |  | SW: WELL GRADED SANDS, GRAVELLY SANDS, LITTLE OR NO FINES.   |
|  | GM: SILTY GRAVELS, POORLY GRADED GRAVEL-SAND-SILT MIXTURES.   |  | GW: WELL GRADED GRAVELS, GRAVEL-SAND MIXTURE, LITTLE OR NO FINES.  |
|  | SM: SILTY SANDS, POORLY GRADED SAND-SILT MIXTURES.  |  | TILL: POORLY SORTED, COMPACTED SILT AND VERY FINE SAND TO FINE SAND AND GRAVEL; PEBBLES OF QUARTZITE, SANDSTONE, SHALE AND GNEISS. |
|  | SP: POORLY GRADED SANDS, GRAVELLY SANDS, LITTLE OR NO FINES.  |  | BEDROCK; UTICA SHALE - BLACK FISSILE SHALE.  |

FIGURE 2.6

**CROSS-SECTION A-A'  
WEST TO EAST**

Pumphouse 5  
Intrinsic Remediation TS  
Griffiss AFB, New York

 **PARSONS  
ENGINEERING SCIENCE, INC.**  
Denver, Colorado

Source: UNC Geotech, 1991.

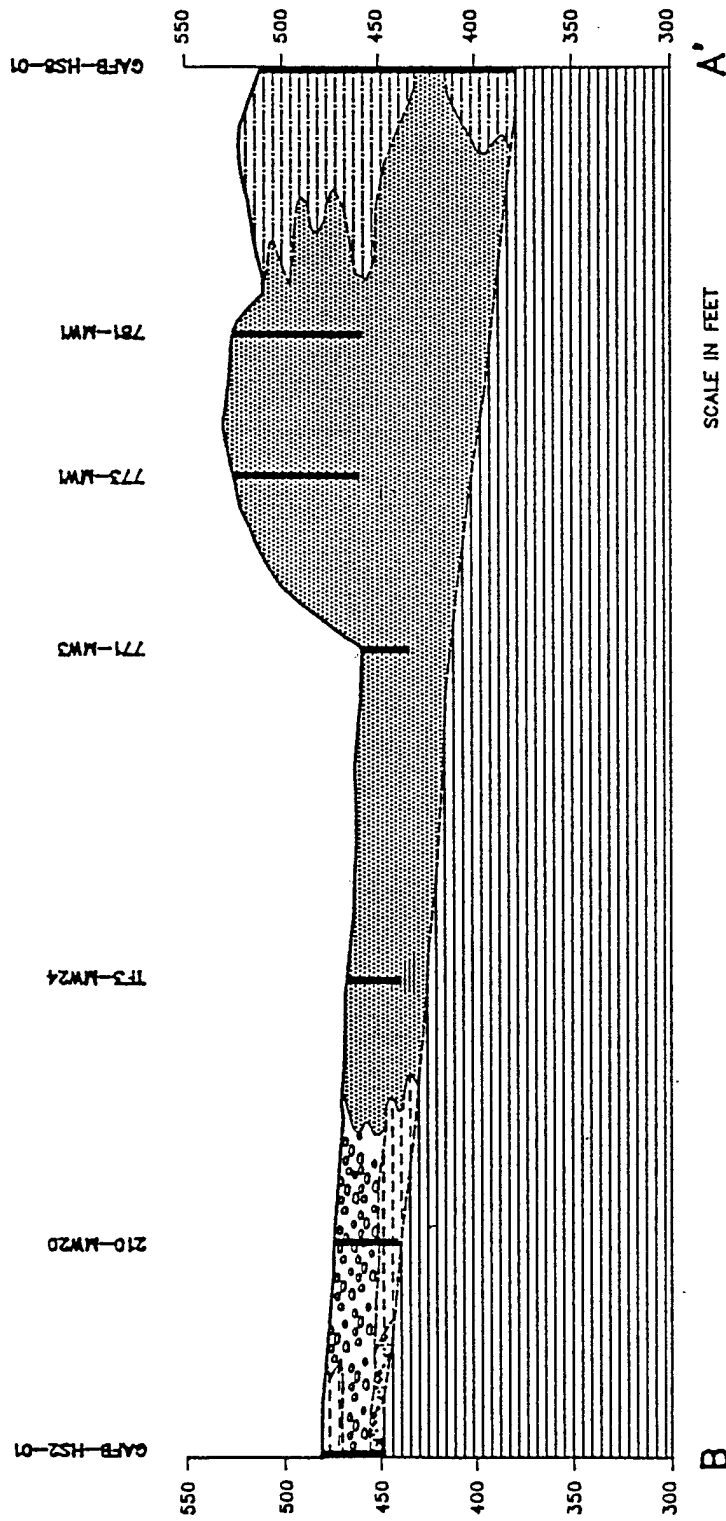

A'

B

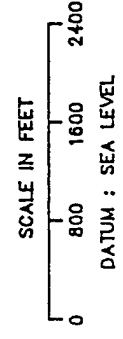

EXPLANATION

- ML; INORGANIC SILTS AND VERY FINE SANDS, ROCK FLOUR, SILTY OR CLAYEY FINE SANDS WITH SLIGHT PLASTICITY.
- SM; SILTY SANDS, POORLY GRADED SAND-SILT MIXTURES.
- BEDROCK; UTICA SHALE - BLACK FISSILE SHALE.
- SW; WELL GRADED SANDS, GRAVELLY SANDS, LITTLE OR NO FINES.
- GW; WELL GRADED GRAVELS, GRAVEL-SAND MIXTURE, LITTLE OR NO FINES.
- TILL; POORLY SORTED, COMPACTED SILT AND VERY FINE SAND TO FINE SAND AND GRAVEL; PEBBLES OF QUARTZITE, SANDSTONE, SHALE AND GNEISS.

FIGURE 2.7

**CROSS-SECTION A'-B'  
SOUTHEAST TO NORTHWEST**

Pumphouse 5  
Intrinsic Remediation TS  
Griffiss AFB, New York



**PARSONS  
ENGINEERING SCIENCE, INC.**  
Denver, Colorado

Source: UNC Geotech, 1991.

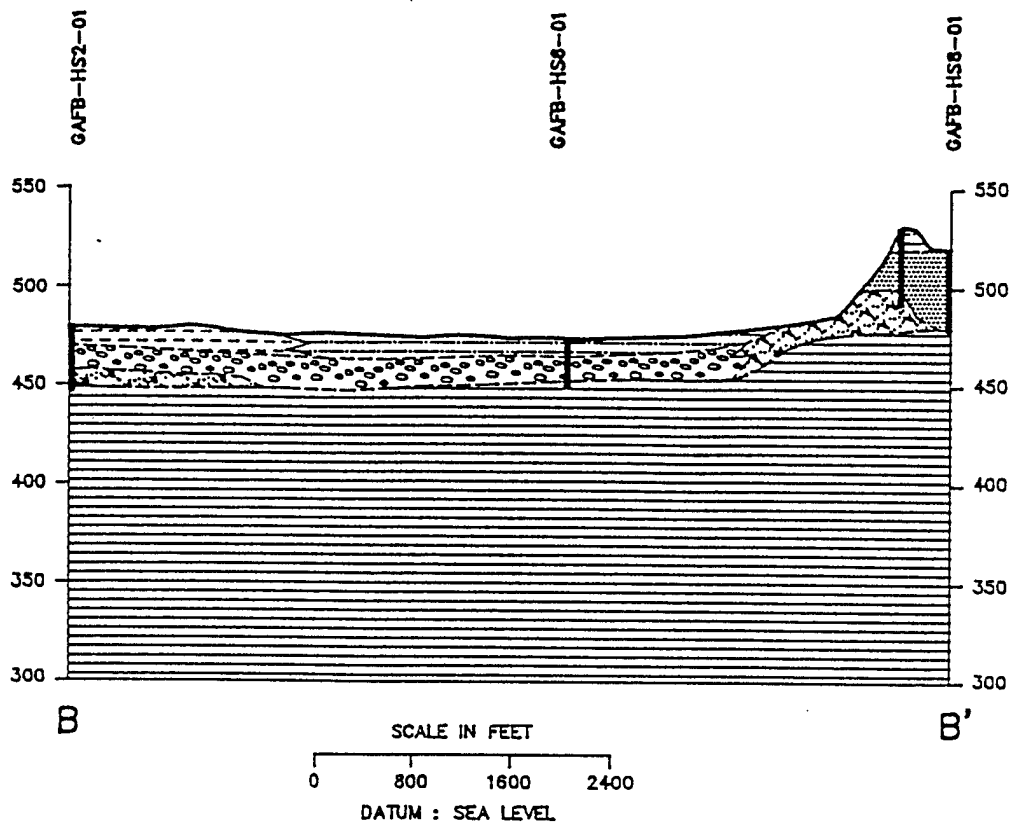

**EXPLANATION**

- |  |   |  |  |
|--|---|--|--|
|  | ML: INORGANIC SILTS AND VERY FINE SANDS, ROCK FLOUR, SILTY OR CLAYEY FINE SANDS WITH SLIGHT PLASTICITY. |  | GW: WELL GRADED GRAVELS, GRAVEL-SAND MIXTURE, LITTLE OR NO FINES.  |
|  | SM: SILTY SANDS, POORLY GRADED SAND-SILT MIXTURES.  |  | TILL: POORLY SORTED, COMPACTED SILT AND VERY FINE SAND TO FINE SAND AND GRAVEL; PEBBLES OF QUARTZITE, SANDSTONE, SHALE AND GNEISS. |
|  | SW: WELL GRADED SANDS, GRAVELLY SANDS, LITTLE OR NO FINES.  |  | BEDROCK; UTICA SHALE - BLACK FISSILE SHALE.  |

**FIGURE 2.8**

**CROSS-SECTION B-B'**  
**WEST TO EAST**

Pumphouse 5  
Intrinsic Remediation TS  
Griffiss AFB, New York

**PARSONS**  
**ENGINEERING SCIENCE, INC.**

Denver, Colorado

Source: UNC Geotech, 1991.

**TABLE 2.1**  
**WELL CONSTRUCTION DETAILS FOR MONITORING WELLS**  
**PUMPHOUSE 5**  
**INTRINSIC REMEDIATION TS**  
**GRIFFISS AFB, NEW YORK**

Location	Installation Date	Well ID (inches)	Northing (ft)	Easting (ft)	Datum Elevation (ft msl) <sup>a/</sup>	Ground Elevation (ft msl)	Length of Screen (ft)	Screen Interval	
								Top (ft bgs) <sup>b/</sup>	Bottom (ft bgs)
771MW-1	5/23/89	2	1175061.39	1135708.30	474.80	473.19	15	9.0	24.0
771MW-2	5/23/89	2	1174971.98	1135703.42	475.66	473.95	15	8.5	23.5
771MW-3	5/23/89	2	1174964.17	1135609.67	474.73	473.50	15	9.0	24.0
771MW-4	12/12/91	2	1175088.22	1135617.12	464.51	NA <sup>c/</sup>	15	4.9	19.9
771MW-5	12/12/91	2	1175648.23	1136414.98	479.19	NA	15	4.9	19.9
771MW-6	12/13/91	2	1174939.20	1135649.22	476.60	NA	15	9.5	24.5
771MW-7	12/13/91	2	NA	NA	NA	NA	15	9.5	24.5
771MW-8	12/14/91	2	1175043.81	1135754.76	476.89	NA	15	9.9	24.9
771MW-9	12/14/91	2	1175086.34	1135803.04	477.16	NA	15	9.6	24.6

<sup>a/</sup> ft msl=Feet above mean sea level.

Source: Law, 1995.

<sup>b/</sup> ft bgs=Feet below ground surface.

<sup>c/</sup> NA=Not available at the time of this report.

**TABLE 2.2**  
**SUMMARY OF GROUNDWATER ELEVATIONS**  
**PUMPHOUSE 5**  
**INTRINSIC REMEDIATION TS**  
**GRIFFISS AFB, NEW YORK**

Well Location	Northing (ft)	Easting (ft)	Datum Elevation (ft msl) <sup>a/</sup>	Screen Interval		Date of Water Level Measurement (mm/dd/yy)	Groundwater Elevation (ft msl)
				Top (ft bgs) <sup>b/</sup>	Bottom (ft bgs)		
771MW-1	1175061.39	1135708.30	474.80	9.0	24.0	11/30/92	459.98
771MW-1	1175061.39	1135708.30	474.80	9.0	24.0	3/3/93	FP <sup>d/</sup>
771MW-1	1175061.39	1135708.30	474.80	9.0	24.0	6/7/93	FP
771MW-1	1175061.39	1135708.30	474.80	9.0	24.0	NA	FP
771MW-2	1174971.98	1135703.42	475.66	8.5	23.5	11/30/92	458.54
771MW-2	1174971.98	1135703.42	475.66	8.5	23.5	3/3/93	458.02
771MW-2	1174971.98	1135703.42	475.66	8.5	23.5	6/7/93	458.90
771MW-2	1174971.98	1135703.42	475.66	8.5	23.5	9/14/93	458.34
771MW-3	1174964.17	1135609.67	474.73	9.0	24.0	11/30/92	458.98
771MW-3	1174964.17	1135609.67	474.73	9.0	24.0	3/3/93	FP
771MW-3	1174964.17	1135609.67	474.73	9.0	24.0	NA	458.98
771MW-3	1174964.17	1135609.67	474.73	9.0	24.0	NA	FP
771MW-4	1175088.22	1135617.12	464.51	4.90	19.9	12/1/93	457.60
771MW-4	1175088.22	1135617.12	464.51	4.90	19.9	3/9/93	457.11
771MW-4	1175088.22	1135617.12	464.51	4.90	19.9	6/8/93	457.74
771MW-4	1175088.22	1135617.12	464.51	4.90	19.9	9/13/93	457.43
771MW-5	1175648.23	1136414.98	479.19	4.90	19.9	11/30/93	472.52
771MW-5	1175648.23	1136414.98	479.19	4.90	19.9	3/11/93	467.39
771MW-5	1175648.23	1136414.98	479.19	4.90	19.9	6/7/93	472.17
771MW-5	1175648.23	1136414.98	479.19	4.90	19.9	9/14/93	470.33
771MW-6	1174939.20	1135649.22	476.60	9.50	24.5	11/30/92	459.69
771MW-6	1174939.20	1135649.22	476.60	9.50	24.5	3/3/93	458.99
771MW-6	1174939.20	1135649.22	476.60	9.50	24.5	6/7/93	460.21
771MW-6	1174939.20	1135649.22	476.60	9.50	24.5	9/14/93	469.21
771MW-7	NA <sup>d/</sup>	NA	NA	9.50	24.5	NA	NA
771MW-7	NA	NA	NA	9.50	24.5	NA	NA
771MW-7	NA	NA	NA	9.50	24.5	NA	NA
771MW-7	NA	NA	NA	9.50	24.5	NA	NA
771MW-8	1175043.81	1135754.76	476.89	9.90	24.9	11/30/92	458.07
771MW-8	1175043.81	1135754.76	476.89	9.90	24.9	3/3/93	457.54
771MW-8	1175043.81	1135754.76	476.89	9.90	24.9	6/7/93	457.96
771MW-8	1175043.81	1135754.76	476.89	9.90	24.9	9/14/93	457.83
771MW-9	1175086.34	1135803.04	477.16	9.60	24.6	11/30/92	458.76
771MW-9	1175086.34	1135803.04	477.16	9.60	24.6	3/3/93	457.94
771MW-9	1175086.34	1135803.04	477.16	9.60	24.6	6/7/93	461.97
771MW-9	1175086.34	1135803.04	477.16	9.60	24.6	9/14/93	458.02

<sup>a/</sup> ft msl = Feet above mean sea level.  
<sup>b/</sup> ft bgs = Feet below ground surface.  
<sup>d/</sup> NA = Not available at the time of this report.  
<sup>e/</sup> FP = Free product in well. Sampling omitted.

Source: Law, 1995.



**LEGEND.**

FP FREE PRODUCT

→ TRIANGULATED DIRECTION OF GROUND-WATER FLOW

--- TRIANGULATION WELL CLUSTER

458.07 WATER LEVEL ELEVATION (ADJUSTED FOR PRODUCT THICKNESS, WHERE REQUIRED)

— 460 GROUNDWATER ELEVATION CONTOUR

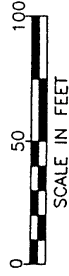

Source: Law, 1994.

**FIGURE 2.9**

**TRIANGULATED GROUNDWATER ELEVATIONS IN THE SURFACE AQUIFER (November 1992 - September 1993)**

Pumphouse 5  
Intrinsic Remediation  
Griffiss AFB, New York



Denver, Colorado

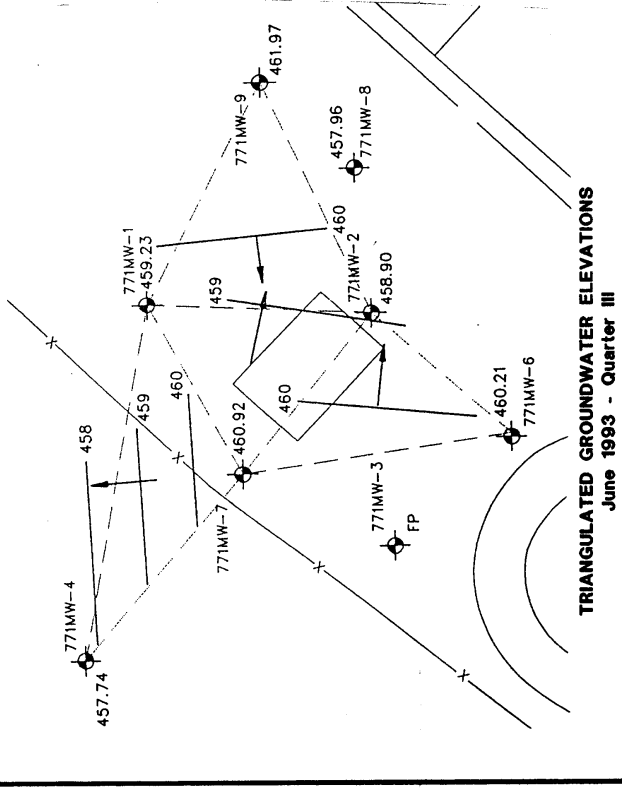
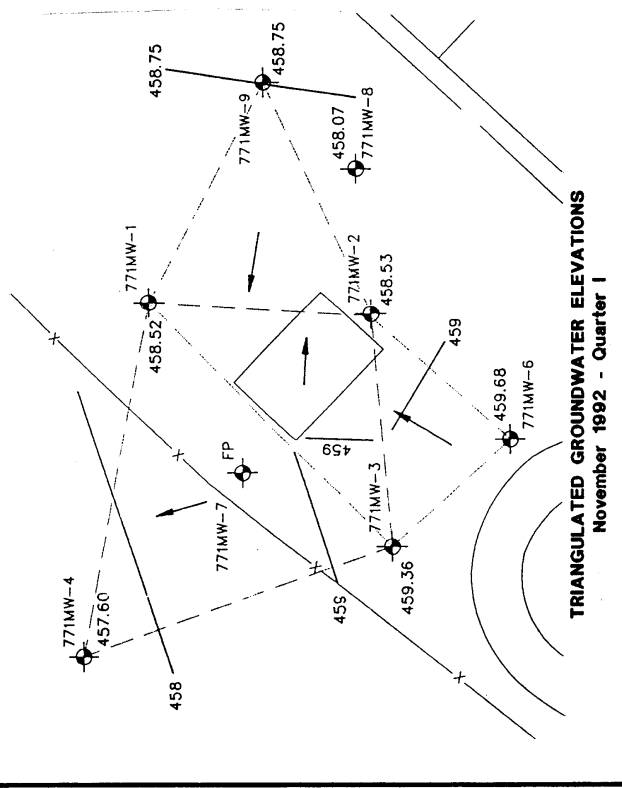
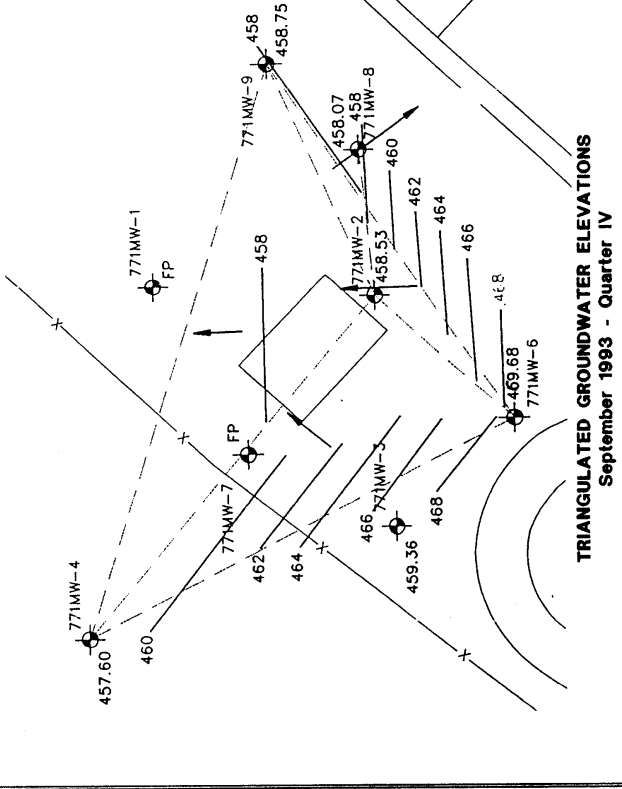
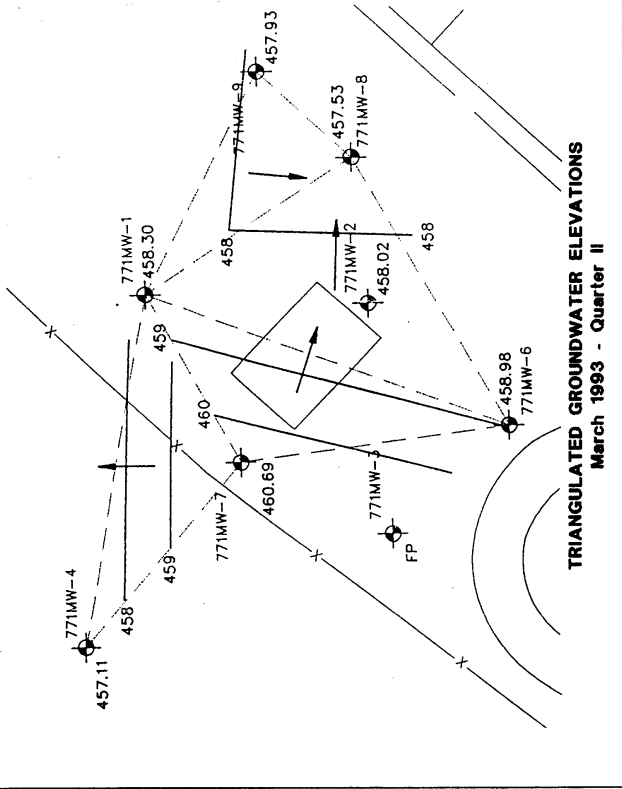

infrastructure, and surface coverage are believed to be significant causes of erratic groundwater flow direction. An uncertain number of the four USTs buried at the site are partially beneath the water table (Jerrard, 1995). Layers of silty sand and clayey sand at 6 to 19 feet bgs (observed at boreholes 771MW-4, 771MW-5, and 771MW-7) may also contribute to some localized groundwater flow irregularities at the site.

Slug tests to measure hydraulic conductivity in the vicinity of Pumphouse 5 were performed in December 1991 (Law, 1995). The average hydraulic conductivity using both rising- and falling-head slug test data (Table 2.3) is  $3.03 \times 10^{-4}$  feet per minute (ft/min) and  $2.19 \times 10^{-3}$  ft/min, respectively. Hydraulic conductivity testing was not performed at 771MW-4 and 771MW-7 due to the presence of free product in the monitoring wells. With a maximum estimated groundwater gradient of 0.060 foot per foot (ft/ft) (measured between monitoring wells 771MW-7 and 771MW-4 using second quarter groundwater data), an assumed porosity of 0.30, and an assumed hydraulic conductivity of  $2.19 \times 10^{-3}$  ft/min, groundwater velocity at the site is anticipated to be as high as  $4.38 \times 10^{-4}$  ft/min or 0.63 feet per day (ft/day).

**TABLE 2.3  
SUMMARY OF HYDRAULIC  
CONDUCTIVITIES  
PUMPHOUSE 5  
INTRINSIC REMEDIATION T5  
GRIFFISS AFB, NEW YORK**

Well	Hydraulic Conductivity <sup>a/</sup> (Falling-Head Test) (ft/min <sup>b/</sup> )	Hydraulic Conductivity (Rising-Head Test) (ft/min)
771MW-5	$1.62 \times 10^{-4}$	$4.22 \times 10^{-3}$
771MW-6	$4.62 \times 10^{-4}$	$1.44 \times 10^{-4}$
771MW-8	$6.87 \times 10^{-4}$	$3.26 \times 10^{-4}$
771MW-9	$1.04 \times 10^{-4}$	$1.73 \times 10^{-3}$

<sup>a/</sup> Calculated using the Bouwer and Rice method (1976). Source: Law, 1995.  
<sup>b/</sup> ft/min = feet per minute.

### 2.1.3 Soil Quality

Available documents do not indicate historical leakage from the Pumphouse 5 fuel system; however, JP-4 contamination was first detected in the late 1980s as floating product that had contaminated soil and groundwater (Parratt-Wolff, Inc., 1989). The

primary sources of JP-4 [a light, nonaqueous phase liquid (LNAPL)] contamination had not been identified, although possible sources are previous spills and overfilling of collection tanks (Section 1.2).

Mobile LNAPL first was detected at the site after the installation of three monitoring wells by Parratt-Wolff, Inc. (771MW-1, -2, and -3) in June 1989. LNAPL levels in June 1989 are unavailable. Since that time, mobile LNAPL has been measured by Griffiss AFB personnel in 20 sampling events spanning from June 1989 to January 1995 (Table 2.4) (Law, 1995). LNAPL levels in the monitoring wells (where detected) over this time span ranged from 0.03 to 5.80 feet. Only monitoring wells 771MW-1, -3, -4, -7, and -8 have exhibited mobile LNAPL contamination.

In response to detected LNAPL contamination, TRC, under contract with UNC Geotech, performed a 90-point soil gas survey in November and December 1989. All soil gas samples were analyzed for BTEX compounds and total petroleum hydrocarbons (TPH). In the immediate vicinity of the pumphouse, a rectangular sample grid with 15-foot centers was established. In addition, a rectangular sample grid with 25-foot centers was located northwest of the pumphouse. All samples were quantitated by gas chromatography/mass spectroscopy (GC/MS) analysis and Dräger tube sampling (UNC Geotech, Inc., 1990). Figures 2.10 and 2.11 show the respective extents of detected soil gas BTEX and soil gas TPH.

Three areas identified during the soil gas study were suspected of having significant residual and/or mobile LNAPL contamination. The largest measured area of soil gas contamination surrounds the four USTs, the pumphouse, the adjacent isolation pits, and the low-point drain northwest of the pumphouse. The highest detected soil gas BTEX and TPH concentrations in this area were 706 nanograms per liter ( $\eta\text{g/L}$ ) and 104,000  $\eta\text{g/L}$ , respectively. Two additional contaminated areas exhibiting soil gas TPH contamination were located approximately 100 feet northwest and 120 feet northeast of Pumphouse 5. The area to the northwest of Pumphouse 5 exhibited soil gas TPH concentrations as high as 219,000  $\eta\text{g/L}$ , while the area to the northeast exhibited soil gas TPH concentrations as high as 129,000  $\eta\text{g/L}$ . Soil gas BTEX concentrations were detected in the northwestern spill zone, but not in the northeastern spill zone. On the basis of soil gas BTEX data, spill sources on the northwest side of Pumphouse 5 appear to be the freshest. The two spill zones northwest and northeast of Pumphouse 5 infrastructure may be resultant of surface releases unrelated to USTs or fuel transfer lines. Analytical data describing potential

**TABLE 2.4**  
**SUMMARY OF FREE PRODUCT THICKNESS MEASUREMENTS<sup>a/</sup>**  
**PUMPHOUSE 5**  
**INTRINSIC REMEDIATION TS**  
**GRIFFISS AFB, NEW YORK**

DATE	771MW-1	771MW-2	771MW-3	771MW-4	771MW-5	771MW-6	771MW-7	771MW-8	771MW-9
Jun-89	FP <sup>b/</sup>	ND <sup>d/</sup>	FP	NI <sup>d/</sup>	NI	NI	NI	NI	NI
Nov-91	2.04	NA <sup>e/</sup>	4.85	NA	NA	NA	NA	NA	NA
Dec-91	NA	NA	NA	0.01	0	0	5.8	0	0
Apr-92	0.23	0	4.1	NA	NA	NA	NA	NA	NA
May-92	0.25	NA	4.1	0	NA	NA	3.06	NA	NA
Jun-92	0.18	0	4.53	NA	NA	NA	NA	NA	NA
Aug-92	0.25	0	4.69	NA	NA	NA	NA	NA	NA
Sep-92	0.11	0	2.02	NA	NA	NA	NA	NA	NA
Oct-92	0.29	0	0.82	NA	NA	NA	NA	NA	NA
Nov-92	0.32	0	0.03	NA	NA	NA	NA	NA	NA
Dec-92	0.39	0	4.35	NA	NA	NA	NA	NA	NA
Jan-93	0.85	0	4.14	NA	NA	NA	NA	NA	NA
Feb-93	0	0	4.31-2.6	NA	NA	NA	NA	NA	NA
Mar-93	0.01	0	0	0	0	0	5.4	0	0
Apr-93	1.32-2.48	0	5.07-4.1	0	0	0	1.45-0.1	0.04-0.46	0
May-93	0.53-0.3	0	4.77-0.1	0	0	0	0.04-0.94	0.59-0.4	0
Jun-93	0.37-0.03	0	0.43-0.01	0	0	0	0.8-0.01	0.27-0.02	0
Jul-93	0.05-0.02	0	0.09-0.02	0	0	0	0.23-0.16	0-0.06	0
Aug-93	0.03	0	0.13	0	0	0	0.24	0.05	0
Oct-93	0.06	0	4.36	0	0	0	0.02	0	0
Jan-95	0.3	0	0.03	0	0	0	2.94	0.23	0

<sup>a/</sup> Values represent product thickness in feet.

<sup>b/</sup> FP = free product detected, level not measured.

<sup>c/</sup> ND = free product not detected.

<sup>d/</sup> NI = well not installed.

<sup>e/</sup> NA = free product measurement not taken.

Source: Law, 1995.

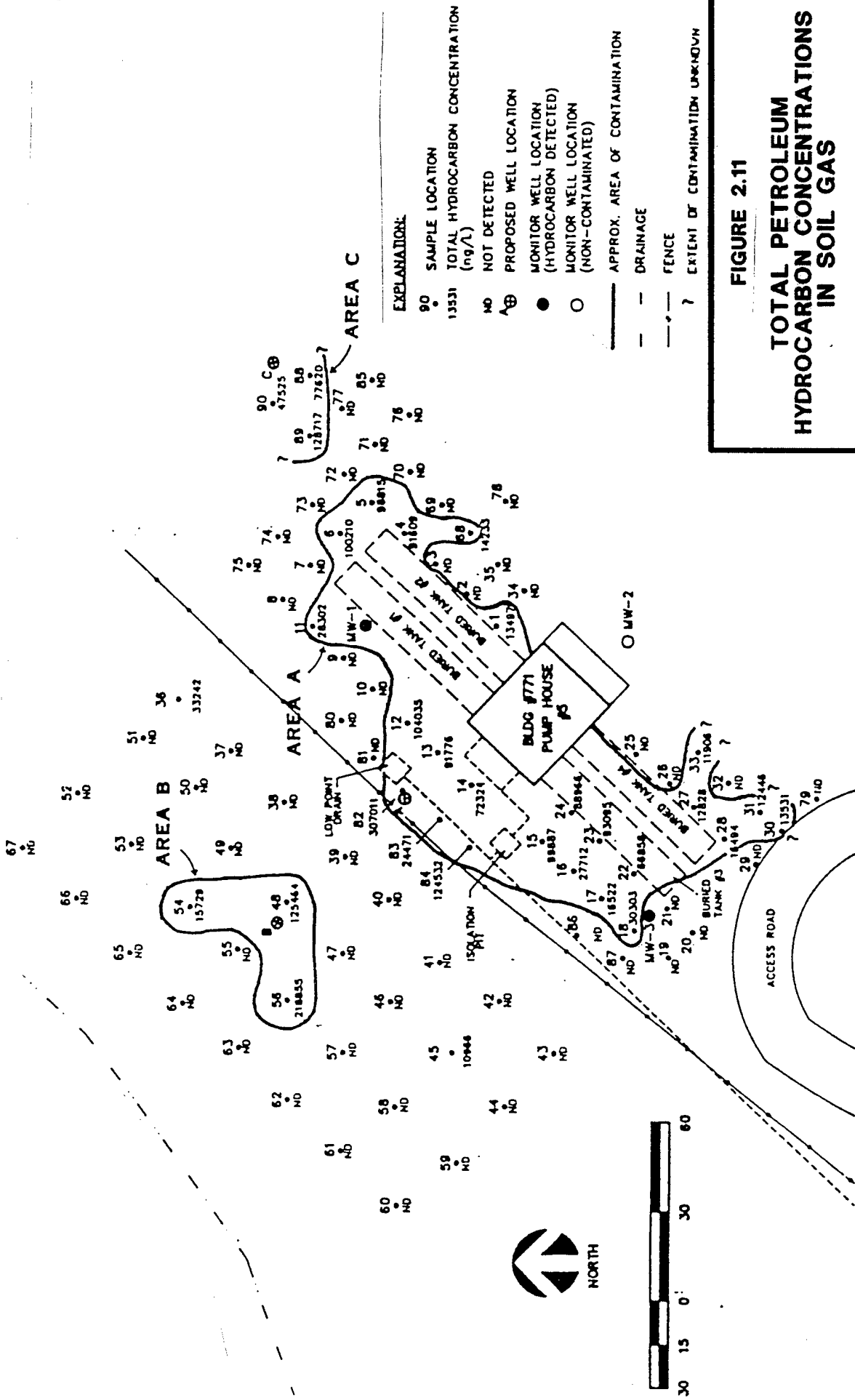

**EXPLANATION:**

- 90 ● SAMPLE LOCATION
- 13531 ○ TOTAL HYDROCARBON CONCENTRATION
- ND ● NOT DETECTED
- ⊕ PROPOSED WELL LOCATION
- MONITOR WELL LOCATION (HYDROCARBON DETECTED)
- MONITOR WELL LOCATION (NON-CONTAMINATED)
- APPROX. AREA OF CONTAMINATION
- - - DRAINAGE
- - - FENCE
- ? EXTENT OF CONTAMINATION UNKNOWN

**FIGURE 2.11**

**TOTAL PETROLEUM  
HYDROCARBON CONCENTRATIONS  
IN SOIL GAS**

Pumphouse 5  
Intrinsic Remediation TS  
Griffiss AFB, New York



**PARSONS  
ENGINEERING SCIENCE, INC.**

Denver, Colorado

Source: UNC Geotech, 1990.

residual JP-4 or motor vehicle gas (MOGAS) contamination sorbed to soils at the site (e.g., using EPA methods SW8020 or SW8015M) are currently unavailable.

A leak-detection survey performed by TRC in October 1991 concluded that no active leaks associated with the underground facilities. Soil gas concentrations of total volatile hydrocarbons (TVH) were not detected around the tanks at Pumphouse 5, but were detected north of the tanks at concentrations as high as 4,500 micrograms per liter ( $\mu\text{g/L}$ ). Following the leak-detection survey, another soil gas survey was performed by TRC for Law in November 1991 (TRC, 1991b). A total of 21 new soil gas survey points were placed to supplement the earlier 1989 soil gas survey performed by TRC under contract to UNC Geotech (1990). Soil gas samples were analyzed for BTEX and short-chained aliphatics. Limited data were produced by this soil gas survey. However, the results of the investigation confirmed earlier soil gas results indicating contaminated soils around the vicinity of Pumphouse 5.

In May 1994, a sample of the fuel floating on the groundwater and a sample of virgin JP-4 were analyzed by capillary GC/MS. The data from these analysis show some slight reductions in the lighter constituents (C3 through C5) in the fuel floating on the groundwater, indicative of slight environmental exposure. The results of the GC/MS analysis are shown in Table 2.5. The data indicate that the LNAPL contamination at well 771MW-7 in May 1994 was relatively fresh. The extent of mobile LNAPL at the site generally corresponds to the locations of the buried tanks and fuel lines: however, the product's estimated northwesterly extent may reflect northwesterly product migration toward the manmade drainage ditch.

#### **2.1.4 Groundwater Quality and Chemistry**

In response to soil gas results obtained in 1989, six additional monitoring wells were installed in December 1989 (771MW-4 through 771MW-9) and sampled for BTEX, TPH (diesel and gasoline), and lead (Law, 1995). Free product in monitoring wells 771MW-4 and 771MW-7 prevented proper well development, and monitoring wells 771MW-1 through 771MW-3 and 771MW-7 were not sampled. Table 2.6 summarizes available groundwater BTEX data. Total BTEX concentrations were detected at monitoring wells 771MW-2, 771MW-4, 771MW-6, and 771MW-8. Monitoring well 771MW-8 exhibited the highest BTEX concentration of 30,600  $\mu\text{g/L}$ . Monitoring well 771MW-7 was also suspected to have BTEX contamination, although it was not sampled because of excessive

**TABLE 2.5**  
**COMPARISON OF PURE JP-4 WITH FREE PRODUCT**  
**FROM MONITORING WELL 771MW-7**  
**PUMPHOUSE 5**  
**INTRINSIC REMEDIATION TS**  
**GRIFFISS AFB, NEW YORK**

Carbon Chain Length	Weight Percent		Percent Increase (Decrease)
	JP-4	771MW-7	
3	0.01	0.00	(100.00%)
4	0.57	0.22	(61.40%)
5	3.10	2.13	(31.29%)
6	14.54	18.45	26.89%
7	18.39	16.04	(12.78%)
8	14.52	14.62	0.69%
9	12.02	12.25	1.91%
10	10.87	10.65	(2.02%)
11	7.57	6.83	(9.78%)
12	6.35	7.62	20.00%
13	5.63	6.19	9.95%
14	3.96	3.22	(18.69%)
15	1.80	1.46	(18.69%)
16	0.52	0.27	(48.08%)
17	0.08	0.03	(62.50%)
18	0.03	0.01	(66.67%)
19	0.04	0.01	(75.00%)

Source: Law, 1995.

**TABLE 2.6**  
**GROUNDWATER BTEX DATA**  
**PUMPHOUSE 5**  
**INTRINSIC REMEDIATION TS**  
**GRIFFISS AFB, NEW YORK**

Well	Date	Method	Benzene (µg/L)	Toluene (µg/L)	Ethylbenzene (µg/L)	Xylenes (µg/L)	Total BTEX (µg/L)
771MW-2	Nov-92	8240	<5	<5	<5	<5	<20
	Mar-93	8240	<5	<5	<5	<5	<20
	Jun-93	8240	<5	<5	<5	<5	<20
	Sep-93	8240	<1	<1.5	<1	<4	<7.5
771MW-2(dup)	Nov-92	8240	<5	<5	<5	<5	<20
	Mar-93	8240	7.6	1.3J <sup>a</sup>	1.1J	2.2J	12.2J
	Jun-93	8240	<5	<5	<5	<5	<20
	Sep-93	8240	<1	<1.5	<1	<4	<7.5
771MW-4	Jan-92	8020	5200* <sup>b</sup>	610* <sup>c</sup>	610*	7500*	13920
	Nov-92	8240	3100	19	450	1200	4769
	Mar-93	8240	4200JD <sup>d</sup>	44J	410	1200	5854JD
	Jun-93	8240	5900JD	29	700JD	1900JD	8529JD
	Sep-93	8240	3200	<1.5	47	180	3427
771MW-5	Jan-92	8020	<0.5	<0.5	<0.5	<1	<2.5
	Nov-92	8240	<5	<5	<5	<5	<20
	Mar-93	8240	<5	<5	<5	<5	<20
	Jun-93	8240	<5	<5	<5	<5	<20
	Sep-93	8240	<1	<1.5	<1	<4	<7.5
771MW-6	Jan-92	8020	<0.5	<0.5	<0.5	<1	<2.5
	Nov-92	8240	2.1J	<5	1.3T <sup>e</sup>	<5	2.1J
	Mar-93	8240	1.1JB <sup>f</sup>	<5	<5	<5	1.1JT
	Jun-93	8240	<5	<5	<5	<5	<20
	Sep-93	8240	<1	<1.5	<1	<4	<7.5
771MW-8	Jan-92	8020	750*	250*	1100*	6600*	8700*
	Nov-92	8240	7800	1300	1200	3600	13900
	Mar-93	8240	8800	1400	1400	4300	15900
	Jun-93	8240	9100JD	1700JD	1600JD	3600JD	16000JD
	Sep-93	8240	6000	380	1000	3800	11180
771MW-8(dup)	Jan-92	8020	11000*	2400*	1200*	16000*	30600*
	Sep-93	8240	6000	380	1000	3800	11180
771MW-9	Jan-92	8020	<0.5	<0.5	<0.5	<1	<2.5
	Nov-92	8240	<5	<5	<5	<5	<20
	Mar-93	8240	<5	<5	<5	<5	<20
	Jun-93	8240	<5	<5	<5	<5	<20
	Sep-93	8240	<1	<1.5	<1	<4	<7.5

<sup>a</sup> J - Concentration estimated.

Source: Law, 1995.

<sup>b</sup> \* - Results from diluted sample.

<sup>c</sup> # - Concentration exceeds the method range (URL).

<sup>d</sup> JD - Estimated result due to dilution.

<sup>e</sup> T - False positive based on trip blank data.

<sup>f</sup> JB - Estimated quantitation: possible biased high or false positive based on QC data.

free product levels. Groundwater contamination suggested the presence of at least two spill sources in the Pumphouse 5 vicinity.

A more extensive groundwater sampling event began in November 1992, as part of a 1-year (four-quarter) groundwater sampling program across Griffiss AFB. Monitoring wells 771MW-1 through 771MW-6 and 771MW-9 were sampled; 771MW-7 still contained free product and was not sampled. The results of this four-quarter sampling event are summarized in Table 2.6. In all four quarters, total BTEX concentrations ranged from 2.1 to 16,000  $\mu\text{g/L}$  in monitoring wells 771MW-2, -4, -6, and -8. Figure 2.12 illustrates the location of detected BTEX contamination. BTEX compounds were not detected in any quarter at monitoring wells 771MW-1, -3, -5, and -9. The highest total BTEX concentrations were measured at wells 771MW-4 and 771MW-5, ranging from 3,427 to 8,529  $\mu\text{g/L}$  and 11,180 and 16,000  $\mu\text{g/L}$ , respectively. BTEX concentrations at 771MW-4 and 771MW-8 appeared to decrease during the last sampling quarter (November 1993), although this is not necessarily indicative of a reduction of soil contamination. Groundwater surface maps indicate (Figure 2.9) that the total extent of BTEX contamination remains undefined and may extend at high concentration to the north or southeast.

Other VOC, SVOC, and glycol contaminants not listed in Table 2.6 were detected at the site. Table 2.7 summarizes these data. Acetone was detected each quarter in all sampled wells at concentrations as high as 4,300  $\mu\text{g/L}$  (771MW-8). The SVOCs naphthalene and 2-methylnaphthalene were detected in all four sampling quarters in wells 771MW-4 and 771MW-8. The highest detected naphthalene concentration was 118.3  $\mu\text{g/L}$  at monitoring well 771MW-8 (Quarter 1, November 1992). The highest detected 2-methylnaphthalene concentration was detected at monitoring well 771MW-8 at 60.4  $\mu\text{g/L}$  (Quarter 1, November 1992). Total glycol was present in wells 771MW-2, 771MW-4, 771MW-6, 771MW-8, and 771MW-9 at concentrations as high as 0.93 mg/L. Total glycol concentrations levels are interpreted to follow a distribution pattern similar to the distribution of the BTEX constituents. The similarity between the glycols and BTEX distribution patterns suggest that the glycol may have entered the groundwater at a locations proximal to where the JP-4 release occurred and/or is a result of widespread deicing operations. Figure 2.13 illustrates the locations of detected glycol contamination.

Under compliance of the Safe Drinking Water Act (SDWA), the State of New York has promulgated state groundwater quality standards that are at least as stringent as federal maximum contaminant levels (MCLs). Table 2.8 summarizes federal MCLs and



TO 771MW-5  
(LOCATED NEAR THE END OF THE APRON)

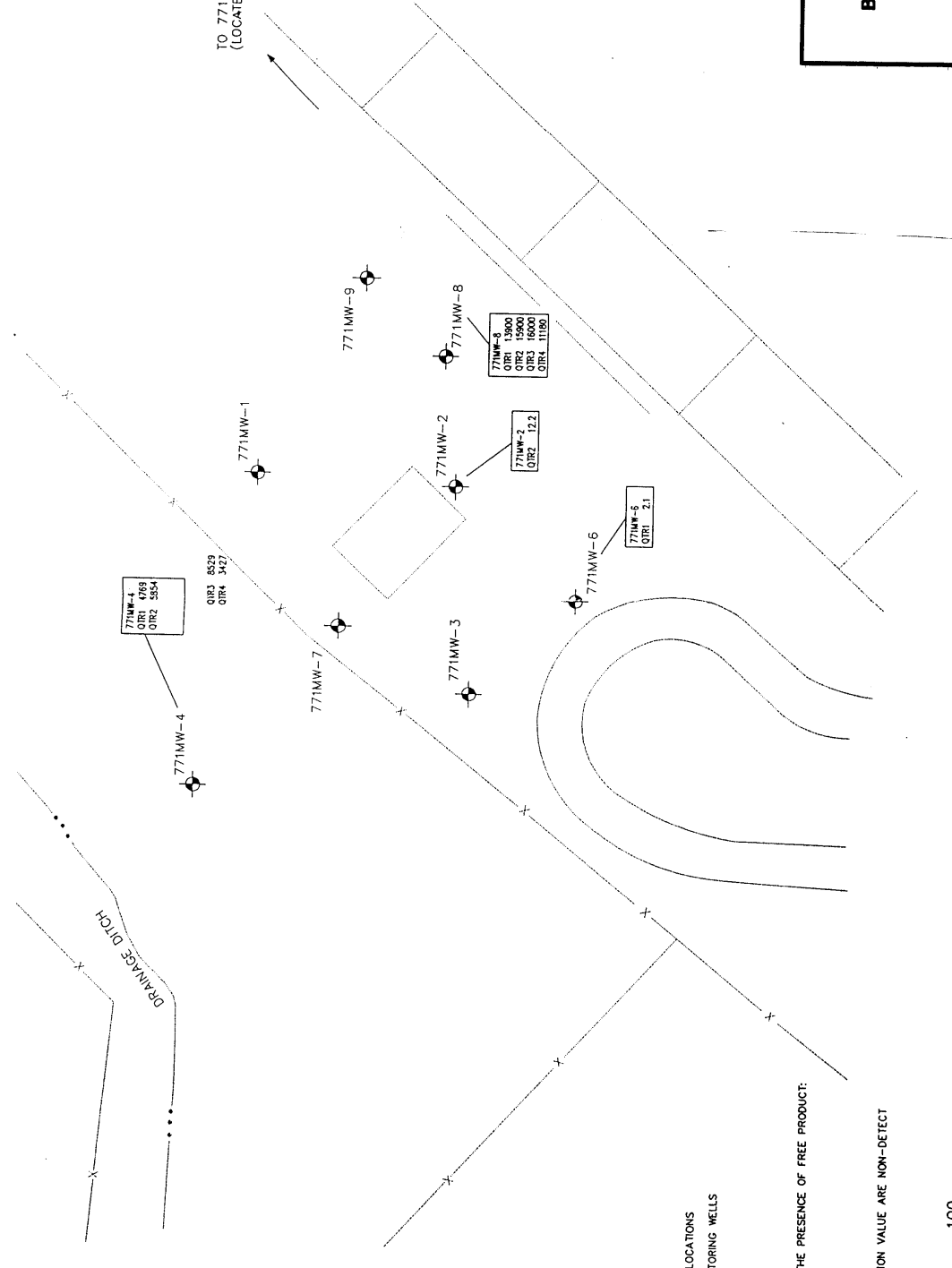

771MW-4  
OTR1 1760  
OTR2 554  
OTR3 829  
OTR4 3427

771MW-2  
OTR1 1390  
OTR2 1590  
OTR3 1600  
OTR4 1090

771MW-2  
OTR1 122

771MW-5  
OTR1 2.1

**LEGEND**

- ◆ SURVEYED WELL LOCATIONS
- ✦ DESTROYED MONITORING WELLS

WELLS NOT SAMPLED DUE TO THE PRESENCE OF FREE PRODUCT:  
771MW-1  
771MW-3  
771MW-7  
781MW-1

WELLS WITHOUT A CONCENTRATION VALUE ARE NON-DETECT

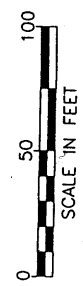

SCALE IN FEET

Source: Law, 1994.

95dn0609, 03/30/95 at 11:00

**FIGURE 2.12**

**BTEX CONCENTRATIONS  
IN GROUNDWATER**

Pumphouse No. 5  
Griffiss Air Force Base  
Rome, New York

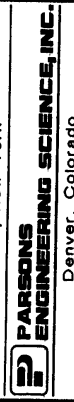

Denver, Colorado

**TABLE 2.7**  
**VOLATILE (NON-BTEX), SEMIVOLATILE, AND GLYCOL COMPOUNDS IN GROUNDWATER - BY QUARTER**  
**(NOVEMBER 1992 - SEPTEMBER 1993)**  
**PUMPHOUSE 5**  
**INTRINSIC REMEDIATION TS**  
**GRIFFISS AFB, NEW YORK**

**Quarter 1, November 1992**

Parameters	Method	Unit	771-MW2	771-MW2(d)	771MW-4	771MW-5	771MW-6	771MW-8	771MW-9
<b>Volatile Organics</b>									
Acetone	SW8240	µg/L	12J <sup>a</sup>	<5	1900	6.2	<5	4300	46
2-Hexanone	SW8240	µg/L	<5	<5	<5	<5	<5	130	<5
Methylene Chloride	SW8240 <sup>c</sup>	µg/L	6.2B <sup>b</sup>	9.5B	7.6B	6.9B	7.3B	7.8B	7.0B
<b>Semivolatile Organics</b>									
2-Methylnaphthalene	SW8270	µg/L	<10	<10	30.2	<10	<10	60.4	<10
Dibenzofuran	SW8270	µg/L	<10	<10	<10	<10	<10	1.0J	<10
Diethyl Phthalate	SW8270	µg/L	<10	<10	<10	<10	<10	1.0J	1.7J
Naphthalene	SW8270	µg/L	<10	<10	61.3	<10	<10	118.3	<10
Phenol	SW8270	µg/L	<10	<10	4.1R <sup>c</sup>	<10	<10	<10	<10
bis(2-ethylhexyl) phthalate	SW8270	µg/L	<10	<10	<10	<10	<10	<10	1.1J
<b>Glycols</b>									
Total Glycol	NYS DOH APC-44	mg/L	0.07T <sup>d</sup>	<0.05	0.08	<0.05	<0.05	<0.05	0.12

**Quarter 2, March 1993**

Parameters	Method	Unit	771-MW2	771-MW2(d)	771MW-4	771MW-5	771MW-6	771MW-8	771MW-9
<b>Volatile Organics</b>									
Acetone	SW8240	µg/L	3.9JB <sup>d</sup>	2.9JB	<50	1.1JB	9.1JB	<250	<5
Chloromethane	SW8240	µg/L	4.8JB	8.1JB	<100	<10	4.2JB	160J	<10
Methyl Ethyl Ketone	SW8240	µg/L	<5	<5	<50	3.4J	<5	<250	<5
Methylene Chloride	SW8240	µg/L	6.2JB	5.1JB	30JB	3JB	4.6JB	210JB	5.1JB
<b>Semivolatile Organics</b>									
2-Methylnaphthalene	SW8270	µg/L	<10	<10	33	<10	<10	2J	<10
Acenaphthene	SW8270	µg/L	<10	<10	<10	<10	<10	1J	<10
Flourene	SW8270	µg/L	<10	<10	<10	<10	<10	1J	<10
Naphthalene	SW8270	µg/L	<10	<10	87	<10	<10	4J	<10
<b>Glycols</b>									
Total Glycol	NYS DOH APC-44	µg/L	0.09J	0.07J	<0.04	<0.04	0.09J	0.09J	0.14J

**TABLE 2.7 (CONCLUDED)**  
**VOLATILE (NON-BTEX), SEMI-VOLATILE, AND GLYCOL COMPOUNDS IN GROUNDWATER - BY QUARTER**  
**(NOVEMBER 1992 - SEPTEMBER 1993)**  
**PUMPHOUSE 5**  
**INTRINSIC REMEDIATION TS**  
**GRIFFISS AFB, NEW YORK**

**Quarter 3, June 1993**

Parameters	Method	Unit	771-MW2	771-MW2(d)	771MW-4	771MW-5	771MW-6	771MW-8	771MW-9
<b>Volatile Organics</b>									
Acetone	SW8240	µg/L	860JD <sup>g</sup>	960JD	2200JD	21.0JB	14.0JB	2400JB	18
Methylene Chloride	SW8240	µg/L	49	16	6.5JB	8.7JB	7.0JB	7.0JB	<5.0
<b>Semivolatile Organics</b>									
2-Methylnaphthalene	SW8270	µg/L	<10	<10	44	<10	<10	13	<10
Naphthalene	SW8270	µg/L	<10	<10	110	<10	<10	64.6	<10
Methyl Ethyl Ketone	SW8270	µg/L	29	11	2200JD	<5	<5	<5	<5
bis(2-ethylhexyl) phthalate	SW8270	µg/L	<10	<10	2.2J	1.8J	<10	1.0J	<10
<b>Glycols</b>									
Total Glycol	NYS DOH APC-44	NA	0.07	0.46	0.11	<0.05	0.93	0.14	0.16

**Quarter 4, September 1993**

Parameters	Method	Unit	771-MW2	771-MW2(d)	771MW-4	771MW-5	771MW-6	771MW-8	771MW-9
<b>Volatile Organics</b>									
Acetone	SW8240	µg/L	1400	870	<50	<50	<50	<25	<500
Methylene Chloride	SW8240	µg/L	<10	12JT <sup>h</sup>	17JT	13JT	12JT	<10	<10
<b>Semivolatile Organics</b>									
2-Methylnaphthalene	SW8270	µg/L	<4.0	<4.4	46	<4.1	<4.1	18	<4.0
Naphthalene	SW8270	µg/L	<3.0	<3.3	130	<3.1	<3.1	89	<3.0
Phenol	SW8270	µg/L	<4.0	<4.4	67	<4.1	<4.1	130	<4.0

Note: Table shows only those compounds detected by the respective analysis.

<sup>g</sup> J - Concentration Estimated.

<sup>h</sup> B - False Positive Based on Blank Data.

<sup>i</sup> R - Data Rejected Due to QC data. Do not Use.

<sup>j</sup> T - False Positive Based upon Trip Blank Data.

<sup>k</sup> JB - Estimated Quantitation (possible high or low bias based on QA/QC data).

<sup>l</sup> JD - Estimated Result Due to Dilution.

<sup>m</sup> JT - Estimated Quantitation (possible high or low bias based on trip blank).

Source: Law, 1995.



TO 771MW-5  
(LOCATED NEAR THE END OF THE APRON)

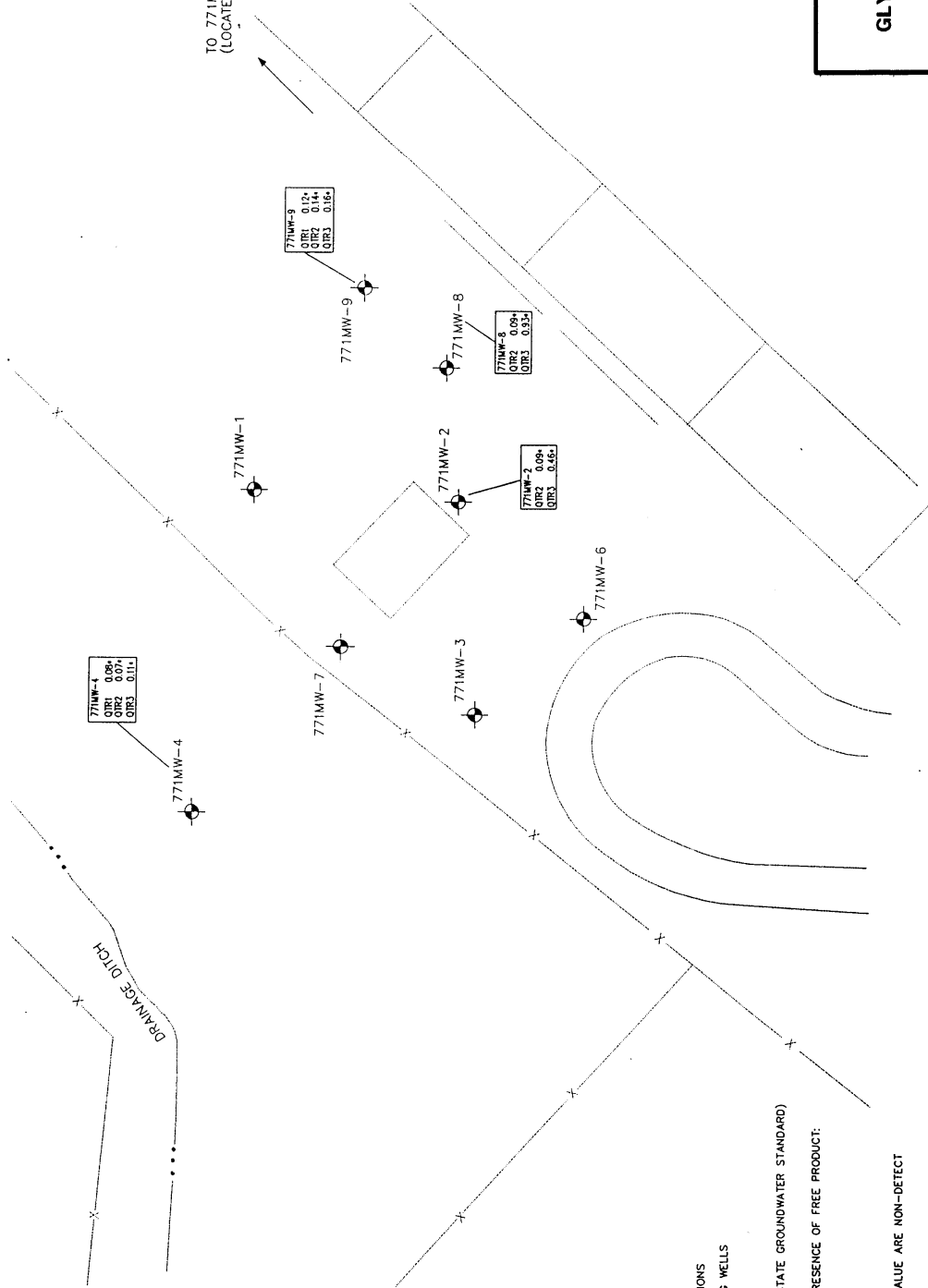

**LEGEND**

- ◆ SURVEYED WELL LOCATIONS
- ✦ DESTROYED MONITORING WELLS

\* ARAR = 0.05 mg/L (STATE GROUNDWATER STANDARD)

WELLS NOT SAMPLED DUE TO THE PRESENCE OF FREE PRODUCT:

- 771MW-1
- 771MW-3
- 771MW-7
- 781MW-1

WELLS WITHOUT A CONCENTRATION VALUE ARE NON-DETECT

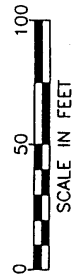

Source: Law, 1994.

**FIGURE 2.13**

**GLYCOL CONCENTRATIONS  
IN GROUNDWATER**

Pumphouse No. 5  
Griffiss Air Force Base  
Rome, New York



Denver, Colorado

**TABLE 2.8**  
**FEDERAL MCLs AND STATE GROUNDWATER STANDARDS**  
**FOR CONTAMINANTS DETECTED AT PUMPHOUSE 5**  
**PUMPHOUSE 5**  
**INTRINSIC REMEDIATION TS**  
**GRIFFISS AFB, NEW YORK**

Compound	Federal MCL <sup>a/</sup> (mg/L)	State Ground Water Standard <sup>b/</sup> (mg/L)
2-Hexanone	NL <sup>c/</sup>	(0.05) <sup>d/</sup>
2-Methylnaphthalene	NL	(0.05)
Acenaphthene	NL	(0.05)
Acetone	NL	(0.05)
Benzene	0.005	0.0007
Bis(2-ethylhexyl) phthalate	0.006	(0.05)
Chloromethane	NL	0.005
Dibenzofuran	NL	(0.05)
Diethyl Phthalate	NL	(0.05)
Ethylbenzene	0.7	0.005
Flourene	NL	(0.05)
Methyl Ethyl Ketone	NL	(0.05)
Methylene Chloride	0.005	0.005
Naphthalene	NL	(0.05)
Phenol	NL	0.001
Toluene	1.00	0.005
Total Gycol	NL	(0.05)
Xylenes	10	0.005

<sup>a/</sup> Drinking Water Regulations and Health Advisories,  
Office of Water, US EPA, December, 1994.

Source: Law, 1994.

<sup>b/</sup> New York State Department of Environmental  
Conservation: Water Quality Standards and Guidance  
Values, November, 1991.

<sup>c/</sup> Not Listed.

<sup>d/</sup> Value in parenthesis is an Unspecified Organic  
Contaminant (UOC) - Most Stringent ARAR shown.

state-promulgated groundwater quality standards for those contaminants detected at Pumphouse 5. Established groundwater classifications for the State of New York (NYCRR, 1991) dictate that groundwater in, and surrounding, Griffiss AFB is within Class GA-specified waters defined as a source of potable water. Therefore, applicable or relevant and appropriate requirements (ARARs) [Griffiss AFB placed in the National Priorities List (NPL) on July 5, 1987] for contaminant concentrations at the site are the most stringent groundwater standards available for the Pumphouse 5 area: The New York State promulgated groundwater quality standards (Table 2.8) are the ARARs for the Pumphouse 5 area. Under New York regulations, organic chemicals are designated as either primary organic contaminants (POC) or unspecified organic contaminants (UOC). ARARs for POCs are defined by a concentration at, or below, 5 µg/L. A primary MCL of 50 µg/L is applied to all UOC compounds, which include all organic chemicals not classified as POCs.

Benzene concentrations exceeded the ARAR (0.7 µg/L) in four of the six groundwater monitoring wells in each sampling quarter from November 1992 to September 1993. Toluene exceeded its ARAR (5 µg/L) in at least one monitoring well in each groundwater sampling quarter. Ethylbenzene and xylenes exceeded ARARs (both at 5 µg/L) in two wells for each groundwater sampling quarter. Other compounds that exceeded ARARs, or were suspected to have exceeded ARARs standards (based on the analytical procedure used), in groundwater at Pumphouse 5 in at least one groundwater sampling quarter were acetone, 2-hexanone, 2-methylnaphthalene, naphthalene, methylene chloride, methyl ethyl ketone, and phenol. Each of these compounds is a UOC compound for which the most stringent ARAR is 50 µg/L.

## 2.2 Development of Conceptual Model

A conceptual model is a three-dimensional representation of the hydrogeologic system based on available geological, hydrological, climatological, and geochemical data. The purpose of developing a site conceptual model is to provide an understanding of the mechanism for contaminant fate and transport and to identify additional data requirements. The model describes known and suspected sources of contamination, types of contamination, affected media, and contaminant migration pathways. The model provides a foundation for formulating decisions regarding additional data collection activities and potential remedial actions. The conceptual model for the Pumphouse 5 site will be used to aid in selecting additional data collection points and to identify appropriate data needs for modeling hydrocarbon degradation using the Bioplume II model.

Successful conceptual model development involves:

- Defining the problem to be solved;
- Integrating available data, including
  - Local geologic and topographic data,
  - Hydraulic data,
  - Site stratigraphic data,
  - Contaminant concentration and distribution data;
- Evaluating contaminant fate and transport characteristics;
- Identifying contaminant migration pathways;
- Identifying potential receptors; and
- Determining additional data requirements.

### **2.2.1 Intrinsic Remediation and the Bioplume II Model**

After a site has been adequately characterized, fate and transport analyses can be performed to determine the potential for contaminant migration and whether any exposure pathway for human or ecological receptors is complete. The Bioplume II model has proved useful for predicting BTEX plume migration and contaminant attenuation by natural biodegradation. The Bioplume II model (Rifai *et al.*, 1988) can be used to evaluate critical groundwater fate and transport processes that may be involved in some of the migration pathways to human and ecological receptors. Quantitative fate and transport analyses can be used to determine what level and extent of remediation is required.

An important consideration in determining whether fuel hydrocarbon contamination presents a substantial threat to human health and the environment and what type of remedial alternative will be most cost effective in eliminating or abating these threats is an accurate estimate of the potential for natural biodegradation of BTEX compounds in the groundwater. Over the past two decades, numerous laboratory and field studies have demonstrated that subsurface microorganisms can degrade a variety of hydrocarbons (Lee *et al.*, 1988). This process occurs naturally when sufficient oxygen (or other electron acceptors) and nutrients are available in the groundwater. The rate of natural biodegradation is generally limited by the lack of electron acceptors rather than by the lack of nutrients such as nitrogen or phosphorus.

### 2.2.2 Biodegradation of Dissolved BTEX Contamination

The Bioplume II model is a well-documented and widely accepted numerical model available for modeling the fate and transport of fuel hydrocarbons under the influence of advection, dispersion, sorption, and natural aerobic and anaerobic biodegradation. The positive effect of these processes on reducing the actual mass of fuel-related contamination dissolved in groundwater has been termed intrinsic remediation. The advantages of intrinsic remediation include: (1) contaminants are transformed to innocuous byproducts (e.g., carbon dioxide and water), not just transferred to another phase or location within the environment; (2) current pump-and-treat technologies are energy-intensive and generally not as effective in reducing residual contamination; (3) the process is nonintrusive and allows continuing use of infrastructure during remediation; (4) current engineered remedial technologies may pose a greater risk to potential receptors than intrinsic remediation because contaminants may be transferred into the atmosphere during remediation activities; and (5) intrinsic remediation is far less costly than conventional, engineered remedial technologies.

To estimate the impact of natural attenuation on the fate and transport of BTEX compounds dissolved in groundwater at a site, two important lines of evidence must be demonstrated (Wiedemeier *et al.*, 1995). The first is a documented loss of contaminants at the field scale. Dissolved concentrations of biologically-recalcitrant tracers found in most fuel contamination are used in conjunction with aquifer hydrogeologic parameters, such as groundwater seepage velocity and dilution, to demonstrate that a reduction in the total contaminant mass is occurring at the site. The second line of evidence involves the use of chemical analytical data in mass balance calculations to show that areas with BTEX contamination can be correlated to areas with depleted electron acceptor (e.g., oxygen, nitrate, and sulfate) concentrations and increases in metabolic fuel degradation byproduct concentrations (e.g., methane and ferrous iron). With this site-specific information, the Bioplume II computer model can be used to simulate the fate and transport of dissolved BTEX compounds under the influence of the process of natural attenuation.

The Bioplume II model is based upon the US Geological Survey (USGS) two-dimensional (2-D) solute transport model (Konikow and Bredehoeft, 1978), which has been modified to include a biodegradation component that is activated by a superimposed plume of dissolved oxygen. Bioplume II solves the USGS 2-D solute equation twice, once for hydrocarbon concentrations in the groundwater and once for a dissolved oxygen plume. The two plumes are then combined using superposition at every particle move to

simulate biological reactions between fuel products and oxygen. If appropriate, biodegradation of contaminants by anaerobic processes is simulated using a first-order anaerobic decay rate.

### 2.2.3 Initial Conceptual Model

Site geologic data were previously integrated to produce a geologic cross-section of the site. Cross-section B - A' (Figure 2.7) shows the dominant hydrostratigraphic units present at the site. Figure 2.9 is a groundwater elevation map prepared using quarterly groundwater elevation data taken from November 1992 through September 1993.

The depth to groundwater at Pumphouse 5 is approximately 15 feet bgs in the sand and gravel deposits in the vicinity of the site. The general flow direction of groundwater is to the north and east on the west side of Pumphouse 5 and to the south and west on the east side of Pumphouse 5. Hydraulic gradients at the site (as high as 0.06 ft/ft) suggest that groundwater velocity may be high, depending on season and location. Vertical gradients are suspected to be minor because of the relative homogeneity of the sands and gravels at the site. Considering both the underlying bedrock (Utica Shale) which acts as a thick confining layer and the potential lack of vertical gradients, possible groundwater migration to deeper aquifers should be minimal. Based on available data, Parsons ES will model the site as an unconfined, fine- to coarse-grained sand and gravel aquifer. This conceptual model will be modified as necessary as additional site hydrogeologic data become available.

LNAPL is still present at Pumphouse 5, although recovery operations using a bioslurper apparatus are expected to begin in June 1995. The fuel/water partitioning models of Bruce *et al.* (1991) or Cline *et al.* (1991) will be used to provide a conservative source term to model the partitioning of BTEX compounds from the free product phase into the groundwater. In order to use one of these models, samples of free product will be collected and analyzed for mass fraction of BTEX compounds. In wells containing LNAPL, Parsons ES will attempt to collect groundwater samples immediately below LNAPL, where possible.

The chemicals of concern for groundwater or surface water at or migrating from the Pumphouse 5 site include VOCs and SVOCs listed in Table 2.7. Glycol contamination also was detected at the site as a potential result of deicing operations. However, the BTEX compounds will be the primary focus of this intrinsic remediation study because of their regulatory importance. The Bioplume II model will simulate the degradation of

BTEX at the UST site and will be used to predict the concentration and extent of the contaminant plume in the groundwater over time.

The chemicals of concern for the site are expected to partition from contaminated unsaturated soil, which contains fuel residuals, or from mobile LNAPL floating on the groundwater surface into the underlying groundwater, and migrate downgradient as a dissolved contaminant plume. In addition to the effects of mass transport mechanisms (volatilization, dispersion, diffusion, and adsorption), these dissolved contaminants will likely be removed from the groundwater system by naturally occurring destructive attenuation mechanisms, such as biodegradation. The effects of these fate and transport processes on the dissolved groundwater plume will be investigated using the quantitative groundwater analytical data and the solute-transport model, Bioplume II. Data collection and analysis requirements are discussed in Section 3 of this work plan.

#### **2.2.4 Potential Pathways and Receptors**

Potential preferential contaminant migration pathways such as groundwater discharge points and subsurface utility corridors (artificial conduits) will be identified during the field work phase of this project. The primary potential migration path for contaminants at the site is from the remaining contaminated soils at the site to the groundwater and from the groundwater to potential receptors via consumption or other use. Shallow groundwater beneath the site flows in varying directions, depending on season and location. However, groundwater north of the site appears to flow in a regular, northerly direction which may potentially intercept a drainage ditch approximately 250 feet northwest of the pump house. There are no known operating potable or nonpotable water wells located downgradient within considerable distance from the site. Surface drainage by overland flow from the site is suspected to be northward toward the drainage ditch; however, other potential discharge points include Sixmile and Threemile Creeks. Because the site is on a secured military Base that is scheduled for deactivation, Base workers and possibly ecological receptors are the probable current receptors of any soil, surface water, or sediment contamination.

The potential for exposure to contaminated water originating from the site through drinking water supplies is low because of the restricted nature of the Base and lack of shallow, potable water wells in the immediate vicinity. Groundwater contamination in residential wells outside the Base was detected in 1987 (ATSDR, 1988) in the form of chlorinated and nonchlorinated VOCs and metals. The migration of contamination to domestic wells as a result of Pumphouse 5 contamination is extremely unlikely due to the

counter-regional flow characteristics of the area. Potable water for the Base and for surrounding areas is supplied through a municipal drinking water treatment plant.

### **2.2.5 Anticipated Remedial Action Plans Unrelated to Griffiss AFB TS**

Pursuant to Section 105 of the Comprehensive Environmental Response Compensation and Liability Act of 1980 (CERCLA), Griffiss AFB was included on the National Priorities List (NPL) on July 5, 1987. Subsequent to the NPL listing of Griffiss AFB in 1987, the USAF, the EPA, and the NYSDEC entered into a Federal Facility Agreement (FFA) effective August 21, 1990 under Section 120 of CERCLA. Under the agreement, 30 sites were identified at Griffiss AFB as areas of concern (AOC) and 9 sites were identified as source AOCs. Designation as a source AOC requires that the site undergo removal actions pursuant to Section 300.5 of the National Contingency Plan (NCP) and Section 101 of CERCLA.

Pumphouse 5 was designated as a source AOC and is slated for excavation activities. Excavation activities will be performed in the summer of 1995 or spring of 1996 to remove LNAPL contamination and contaminated soils in and around Pumphouse 5 (Jerrard, 1995). The excavation will include removal of the four USTs and the pumphouse. Figure 2.14 illustrates the areas anticipated for soil removal.

Prior to excavation, a vacuum-mediated pumping or bioslurping demonstration project will be implemented by AFCEE to evaluate bioslurping's performance and cost-effectiveness. Specially modified bioslurper wells may be installed during this demonstration project which is scheduled to begin in June 1995. The bioslurping and intrinsic remediation (subject of this report) demonstration projects both are sponsored by AFCEE, which seeks to document innovative remedial technologies at Air Force bases throughout the US.

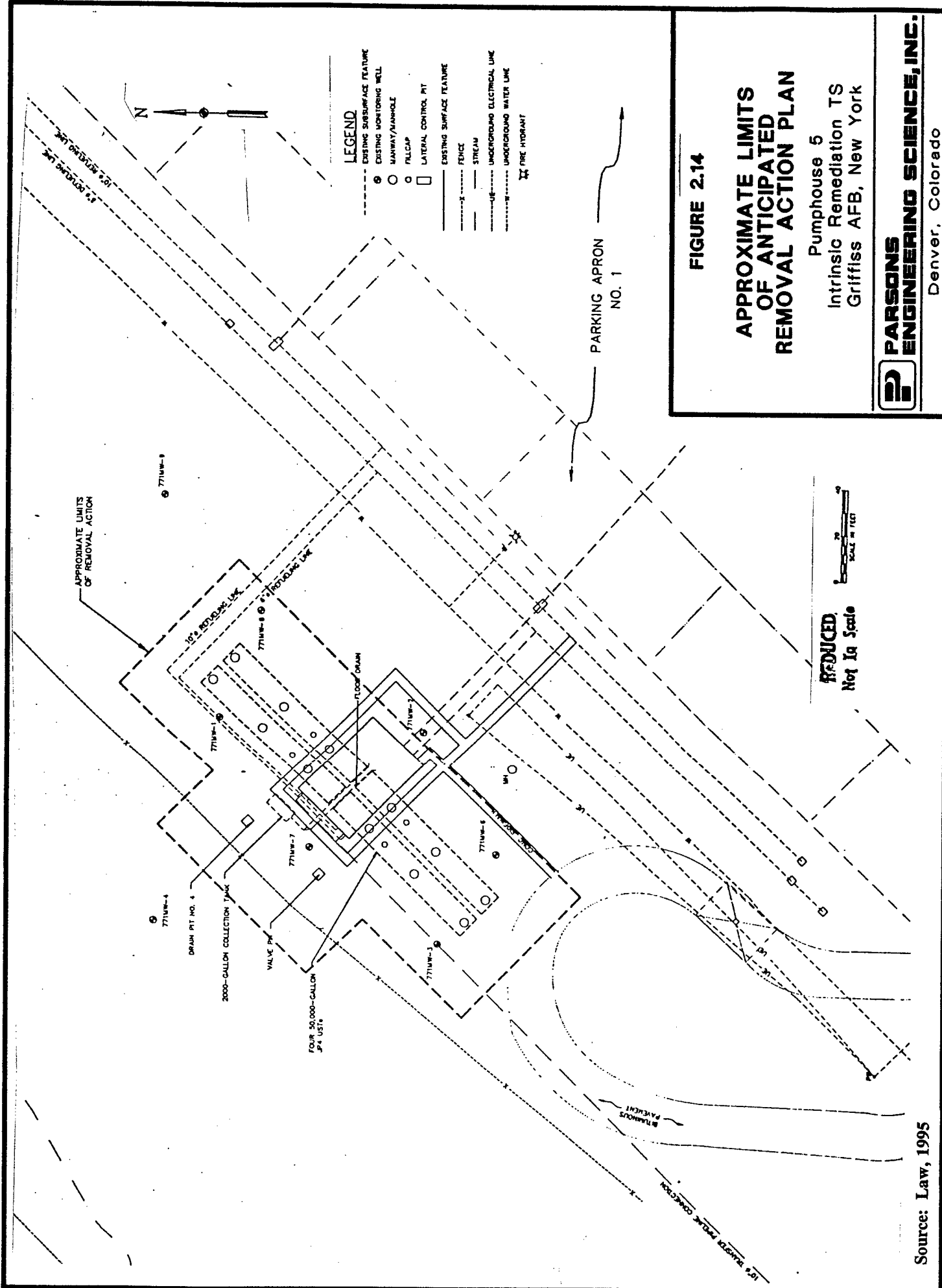

FIGURE 2.14

**APPROXIMATE LIMITS OF ANTICIPATED REMOVAL ACTION PLAN**

Pumphouse 5  
 Intrinsic Remediation TS  
 Griffiss AFB, New York

**PARSONS ENGINEERING SCIENCE, INC.**  
 Denver, Colorado

Source: Law, 1995

## SECTION 3

### COLLECTION OF ADDITIONAL DATA

To complete the TS and to evaluate the rates and patterns of intrinsic remediation of fuel-related contaminants, additional site-specific hydrogeologic data will be collected. The physical and chemical hydrogeologic parameters listed below will be determined during the field work phase of the TS.

Physical hydrogeologic characteristics to be determined include:

- Depth from measurement datum to the groundwater surface in existing monitoring wells;
- Locations of potential groundwater recharge and discharge areas;
- Locations of downgradient wells and their uses;
- Hydraulic conductivity through slug tests, as required;
- Estimate of dispersivity, where possible;
- Stratigraphic analysis of subsurface media;
- Temperature; and
- Determination of extent and thickness of mobile and residual LNAPL.

Chemical hydrogeologic characteristics to be determined include:

- Dissolved oxygen concentration;
- Specific conductance;
- pH;
- Chemical analysis of free product (if present) to determine mass fraction of BTEX; and
- Additional chemical analysis of groundwater and soil for the parameters listed in Table 3.1.

To obtain these data, soil, groundwater, and free product samples will be collected and analyzed. The following sections describe the procedures that will be followed when collecting additional site-specific data. Drilling, soil sampling, and well point installation will be accomplished using the Geoprobe® system, which is described in Sections 3.1 and

**TABLE 3.1  
ANALYTICAL PROTOCOL FOR  
GROUNDWATER AND SOIL SAMPLES  
PUMPHOUSE 5  
INTRINSIC REMEDIATION TS  
GRIFFISS AFB, NEW YORK**

MATRIX	METHOD	FIELD (F) OR ANALYTICAL LABORATORY (L)
<b>WATER</b>		
Total Iron	Colorimetric, HACH Method 8008 (or similar)	F
Ferrous Iron (Fe+2)	Colorimetric, HACH Method 8146 (or similar)	F
Ferric Iron (Fe+3)	Difference between total and ferrous iron	F
Manganese	Colorimetric, HACH Method 8034 (or similar)	F
Sulfide	Colorimetric, HACH Method 8131 (or similar)	F
Sulfate	Colorimetric, HACH Method 8051 (or similar)	F
Nitrate	Titrimetric, HACH Method 8039 (or similar)	F
Nitrite	Titrimetric, HACH Method 8507 (or similar)	F
Redox Potential	A2580B, direct reading meter	F
Oxygen	Direct reading meter	F
pH	E150.1/SW9040, direct reading meter	F
Conductivity	E120.1/SW9050, direct reading meter	F
Temperature	E170.1	F
Alkalinity (Carbonate [CO3-2] and Bicarbonate [HCO3-1])	Titrimetric, HACH Method 8221 (or similar)	F
Carbon Dioxide	CHEMetrics Method 4500	F
Nitrite	E300 or SW9056	L
Chloride	E300 or SW9056	L
Sulfate	E300 or SW9056	L
Alkalinity	E150.1	L
Methane	RSKSOP-147	L
Aromatic Hydrocarbons (Including Trimethylbenzene and Tetramethylbenzene)	SW8020 (RSKSOP-133)	L
Total Hydrocarbons	SW8015M	L
Volatile Organics	GC/MS method, SW8240	L
Free Product	GC/MSD fuel identification	L
Ammonia--Diss. Gas in Water	Standard Method 4500-NH3F	L
Semivolatile Organics	SW8270 (five samples or less per site)	L
<b>SOIL</b>		
Total Organic Carbon	SW9060	L
Moisture	ASTM D-2216	L
Aromatic Hydrocarbons	SW8020	L
Total Hydrocarbons	SW8015M	L

3.2. Procedures to be used to collect soil core samples are described in Section 3.1. Procedures to be used for the installation of new monitoring points are described in Section 3.2. Procedures to be used to sample existing groundwater monitoring wells and newly installed groundwater monitoring points are described in Section 3.3. Procedures used to measure aquifer parameters (e.g. hydraulic conductivity) are described in Section 3.4.

### **3.1 SOIL SAMPLING**

The following subsections describe sample collection techniques, sampling locations at the site, equipment decontamination procedures, site restoration, and management of investigation-derived waste materials.

#### **3.1.1 Sample Collection Using the Geoprobe® System**

The Geoprobe® system is a hydraulically powered percussion/probing machine used to advance sampling tools through unconsolidated soils. This system provides for the rapid collection of soil, soil gas, and groundwater samples at shallow depths while minimizing the generation of investigation-derived waste materials. Figure 3.1 is a diagram of the Geoprobe® system. The following sections describe soil sample collection methods, well point installation methods, and decontamination methods using the Geoprobe® system.

Soil samples will be collected using a probe-drive sampler. The probe-drive sampler serves as both the driving point and the sample collection device and is attached to the leading end of the probe rods. To collect a soil sample, the sampler is pushed or driven to the desired sampling depth, the drive point is retracted, which opens the sampling barrel, and the sampler is subsequently pushed into the undisturbed soils. The soil cores are retained within brass, stainless steel, or clear acetate liners inside the sampling barrel. The probe rods are then retracted, bringing the sampling device to the surface. The soil sample can then be extruded from the liners for logging or the liners can be capped and undisturbed samples submitted to the analytical laboratory for testing.

If the probe-drive sampling techniques described above are inappropriate, inadequate, or unable to efficiently provide sufficient soil samples for the characterization of the site, continuous soil samples will be obtained from conventional core boreholes using a hand auger or similar method judged acceptable by the Parsons ES field scientist. Procedures will be modified, if necessary, to ensure good sample recovery.

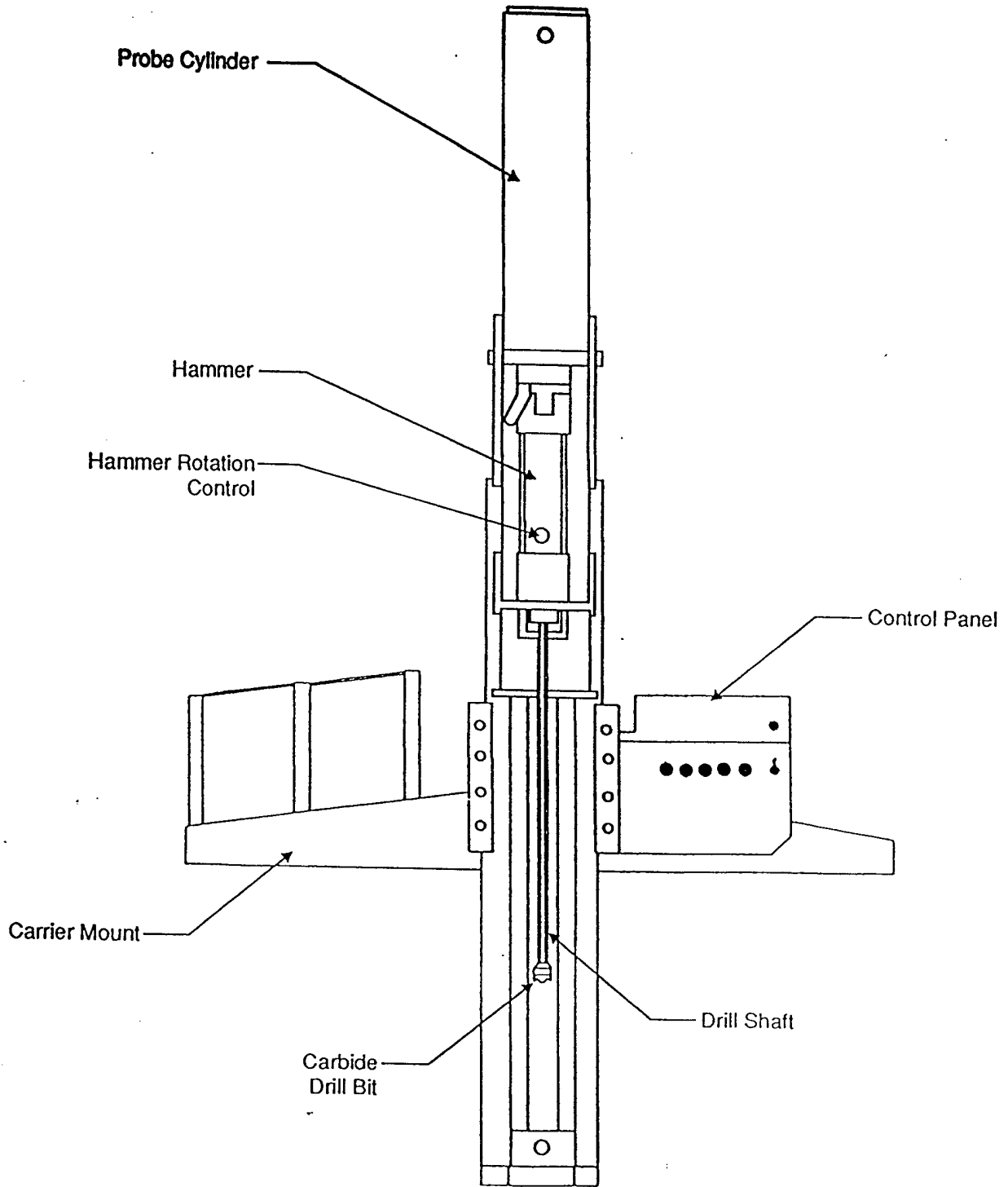

FIGURE 3.1

**CROSS-SECTION  
OF GEOPROBE**

Pumphouse 5  
Intrinsic Remediation TS  
Griffiss AFB, New York



**PARSONS  
ENGINEERING SCIENCE, INC.**

Denver, Colorado

The Parsons ES field scientist will be responsible for observing all field investigation activities, maintaining a detailed descriptive log of all subsurface materials recovered during soil coring, photographing representative samples, and properly labeling and storing samples. An example of the proposed geologic boring log form is presented in Figure 3.2. The descriptive log will contain:

- Sample interval (top and bottom depth);
- Sample recovery;
- Presence or absence of contamination;
- Lithologic description, including relative density, color, major textural constituents, minor constituents, porosity, relative moisture content, plasticity of fines, cohesiveness, grain size, structure or stratification, relative permeability, and any other significant observations; and
- Depths of lithologic contacts and/or significant textural changes measured and recorded to the nearest 0.1 foot.

Base personnel will be responsible for identifying the location of all utility lines, USTs, fuel lines, or any other underground infrastructure prior to any sampling activities. All necessary digging permits will be obtained by Base personnel prior to mobilizing to the field. Base personnel will also be responsible for acquiring drilling and monitoring point installation permits for the proposed locations. Parsons ES will be responsible for providing trained operators for the Geoprobe®.

### **3.1.2 Soil Sample Locations and Required Analyses**

Soil samples will be collected at six proposed Geoprobe® and/or monitoring point installation locations. Table 3.1 presents an analytical protocol for groundwater and soil samples, and Appendix A contains detailed information on the analyses and methods used during this sampling effort. Figure 3.3 identifies the six proposed locations of soil sample collection at Pumhouse 5. A minimum of two samples will be taken in each hole punched: one sample will be taken at the water table and one will be taken at the depth of maximum BTEX contamination in the vadose zone as determined by soil headspace screening. Soil samples will be collected in the vicinity of buried USTs at Pumhouse 5. Samples also will be taken in the direction of groundwater flow. In addition, a proposed sediment samples from the bank of the creek to the north of the site will be collected to determine mobile or residual product has migrated north to the creek. Additional samples and sampling intervals will be collected at the discretion of the Parsons ES scientist.

# GEOLOGIC BORING LOG

Sheet 1 of 1

BORING NO.: \_\_\_\_\_ CONTRACTOR: \_\_\_\_\_ DATE SPUD: \_\_\_\_\_  
 CLIENT: AFCEE RIG TYPE: \_\_\_\_\_ DATE CMPL.: \_\_\_\_\_  
 JOB NO.: 722450.19 DRLG METHOD: \_\_\_\_\_ ELEVATION: \_\_\_\_\_  
 LOCATION: GRIFFISS AFB BORING DIA.: \_\_\_\_\_ TEMP: \_\_\_\_\_  
 GEOLOGIST: \_\_\_\_\_ DRLG FLUID: \_\_\_\_\_ WEATHER: \_\_\_\_\_  
 COMENTS: \_\_\_\_\_

Elev (ft)	Depth (ft)	Pro- file	US CS	Geologic Description	Sample		Penet Res	PID(ppm)	TLV(ppm)	TOTAL BTEX(ppm)	TPH (ppm)
					No.	Depth (ft)					
	1										
	5										
	10										
	15										
	20										
	25										
	30										
	35										

**NOTES**

- bgs - Below Ground Surface
- GS - Ground Surface
- TOC - Top of Casing
- NS - Not Sampled
- SAA - Same As Above

**SAMPLE TYPE**

- D - DRIVE
- C - CORE
- G - GRAB

▼ Water level drilled

**FIGURE 3.2**

## GEOLOGIC BORING LOG





Pumphouse 5  
 Intrinsic Remediation TS  
 Griffiss AFB, New York

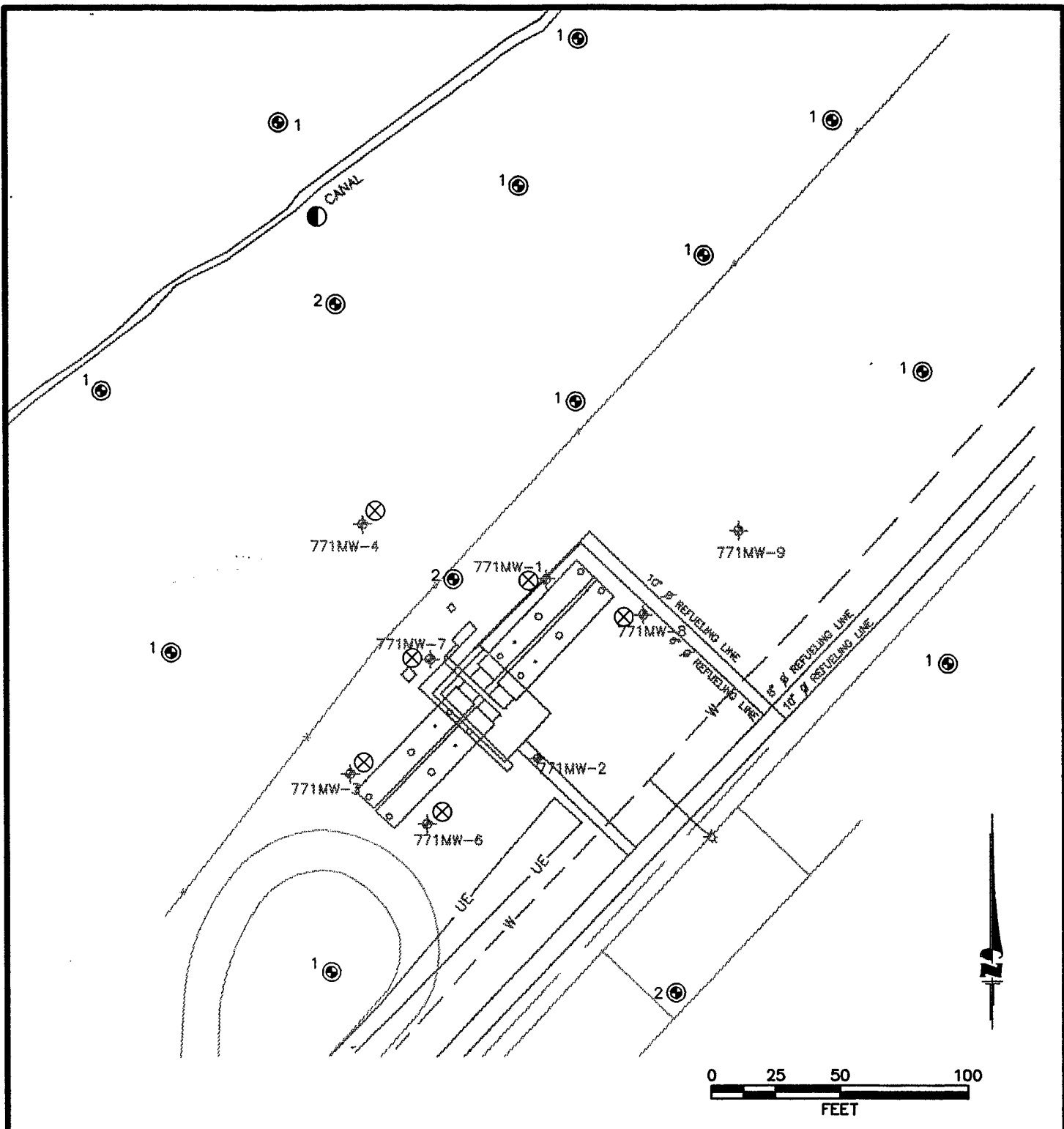

Denver, Colorado



**LEGEND**

- 
 CURRENT MONITORING WELL LOCATION  
 771MW-6
- 
 PROPOSED SAMPLING AND/OR MONITORING POINT LOCATION OR GROUNDWATER GRAB SAMPLES, WITH PROPOSED NUMBER OF NESTED WELLS PER LOCATION
- 
 PROPOSED SOIL SAMPLING LOCATION
- 
 PROPOSED SEDIMENT/SURFACE WATER SAMPLING LOCATION

**FIGURE 3.3**

**PROPOSED GEOPROBE SAMPLING AND/OR MONITORING POINT INSTALLATION LOCATIONS**

Pumphouse 5  
 Intrinsic Remediation TS  
 Griffiss AFB, New York

---

**PARSONS ENGINEERING SCIENCE, INC.**  
 Denver, Colorado

A portion of the sample will be sent to the laboratory for analytical analysis while another portion of the sample will be utilized to determine soil headspace. Each laboratory soil sample will be placed in an analyte-appropriate sample container and shipped to the analytical laboratory for analysis of total hydrocarbons, aromatic hydrocarbons, and moisture content using the procedures presented in Table 3.1. In addition, samples from uncontaminated locations will be analyzed for total organic carbon (TOC). Each headspace screening sample will be placed in a sealed plastic bag or mason jar and allowed to sit for at least 5 minutes. Soil headspace will then be determined using an organic vapor meter (OVM), and the results will be recorded by the Parsons ES field scientist.

### **3.1.3 Datum Survey**

The horizontal location of all soil sampling locations relative to established Base coordinates will be measured by a surveyor. Horizontal coordinates will be measured to the nearest 0.1 foot. The elevation of the ground surface will also be measured to the nearest 0.1 foot relative to USGS msl data.

### **3.1.4 Site Restoration**

After sampling is complete, each sampling location will be restored as closely to its original condition as possible. Holes created by the Geoprobe® in sandy soils similar to those found at the Base tend to cave in soon after extraction of the drive sampler. However, any test holes remaining open after extraction of the Geoprobe® rod will be sealed with bentonite chips, pellets, or grout to eliminate any creation or enhancement of contaminant migration pathways to the groundwater. Soil sampling using the Geoprobe® creates low volumes of soil waste. Soil not used for sampling will be scattered around the site or placed in 55-gallon drums provided by the Base, depending on the field screening results. Disposal of containerized soil will be handled by Base personnel. Alternate methods of soil waste disposal will be considered by the Parsons ES field scientist as recommended by Base personnel.

### **3.1.5 Equipment Decontamination Procedures**

Prior to arriving at the site, and between each sampling location, probe rods, tips, sleeves, pushrods, samplers, tools, and other downhole equipment will be decontaminated using a high-pressure, steam/hot water wash. Only potable water will be used for decontamination. All rinseate will be collected either in a decontamination pit or in buckets provided by Parsons ES. A headspace analysis of collected rinseate will be taken by qualified Parsons ES personnel with an organic vapor meter (OVM). Rinseates with

headspace readings less than 5 parts per million on a volume-per-volume basis (ppmv) will be disposed of onsite. A shallow disposal pit may be dug to help recharge and aerate disposed rinseate waters onsite (at the discretion of Griffiss AFB personnel). Soils excavated from this disposal pit will be replaced at the end of site characterization activities. Rinseates with headspace readings greater than 5 ppmv will be transferred to 55-gallon drums provided by the Base and later transported and disposed of by Base personnel. Base personnel are responsible for sampling the contents of the drums to identify any hazardous constituents before the drums are transported to an appropriate disposal facility.

Between collection of each soil sample, the sampling barrel will be disassembled and decontaminated with Alconox<sup>®</sup> and potable water, then swabbed with isopropyl alcohol. The barrel will then be rinsed with deionized water and reassembled with new liners. Between uses, the sampling barrel will be wrapped in clean plastic or foil to prevent contamination.

Potable water to be used during equipment cleaning, decontamination, or grouting will be obtained from one of the Base water supplies. Water use approval will be verified by contacting the appropriate facility personnel. The field scientist will make the final determination as to the suitability of site water for these activities. Precautions will be taken to minimize any impact to the surrounding area that might result from decontamination operations.

### **3.2 GROUNDWATER SAMPLING**

To further characterize the hydrogeologic conditions of the shallow subsurface, up to 19 groundwater monitoring points (shallow and/or deep) may be installed at the site to supplement the existing site monitoring wells. The following sections describe the proposed sampling locations and intervals, monitoring point installation, monitoring point development, and equipment decontamination procedures.

#### **3.2.1 Monitoring Point Locations and Completion Intervals**

The locations of 19 proposed groundwater monitoring points or grab sample locations are identified for the site on Figure 3.3. The exact locations for the new groundwater collection locations will be determined based on previous site data and site data generated by Parsons ES through the proposed field activities. Monitoring point and grab sample locations will be selected to provide hydrogeologic data necessary for successful implementation of the Bioplume II model and to monitor potential fuel hydrocarbon

migration from the site. Monitoring point and grab sample locations will be selected to define three aspects of the site: 1) the extent of contamination, 2) the horizontal and vertical distribution of dissolved BTEX, and 3) the hydrogeology and groundwater flow direction at the site. Monitoring point placement also will be governed by the anticipated excavation of soils and structures at Pumphouse 5 within the next year. Monitoring points may be placed outside of the anticipated zones of soil excavation (Figure 2.14), especially toward the drainage ditch to the north, which is downgradient of the site. A proposed surface water sample location (Figure 3.3) will be taken from the creek to the north of the site.

Each monitoring point will have a screened interval of 1 meter. One nested monitoring pair will have a point with a shallow screened interval and a point with a deep screened interval. The exact depth of monitoring points will be determined by the Parsons ES field scientist depending on site conditions. The proposed screened intervals of 1 meter for shallow and deep monitoring points will help mitigate the dilution of water samples from potential vertical mixing of contaminated and uncontaminated groundwater in the monitoring point casing, and will give important information on the nature of vertical hydraulic gradients in the area. Adjustments of the depth and length of the screened interval of the monitoring points may be necessary in response to actual aquifer conditions and contaminant distribution identified during Geoprobe<sup>®</sup> testing.

### **3.2.2 Monitoring Point Installation Procedures**

#### **3.2.2.1 Pre-Placement Activities**

All necessary digging, coring, and drilling permits will be obtained prior to mobilizing to the field. In addition, all utility lines will be located, and proposed drilling locations will be cleared prior to any intrusive activities. Responsibilities for these permits and clearances are discussed in Section 3.1.1.

Water to be used in monitoring point installation and equipment cleaning will be obtained from one of the Base water supplies. Water use approval will be verified by contacting the appropriate facility personnel. The field scientist will make the final determination as to the suitability of site water for these activities.

#### **3.2.2.2 Monitoring Point Materials Decontamination**

Monitoring point installation and completion materials will be inspected by the field scientist and determined to be clean and acceptable prior to use. If not factory sealed, the

well points and tubing will be cleaned prior to use with a high-pressure, steam/hot-water cleaner using approved water. Materials that cannot be cleaned to the satisfaction of the field scientist will not be used.

### **3.2.2.3 Installation and Materials**

This section describes the procedures to be used for installation of monitoring points. Monitoring points will be installed using either 0.375-inch Teflon<sup>®</sup> tubing connected to a 0.5-inch-diameter stainless steel screen or a 0.5-inch inside-diameter (ID)/0.75-inch outside-diameter (OD) PVC screen and casing.

#### **3.2.2.3.1 Deep Monitoring Points**

The deep monitoring points will be installed in boreholes punched using the Geoprobe<sup>®</sup>. The deep monitoring points will be constructed of a sacrificial drive point attached to a length of 0.5-inch-diameter stainless steel mesh or slotted schedule 40 polyvinyl chloride (PVC) well screen, which is in turn connected to 0.375-inch Teflon<sup>®</sup> tubing (steel screen) or 0.5-inch PVC casing (PVC screen).

To install the deep monitoring points, the borehole is punched and sampled to several feet above the target depth for the monitoring point. The probe rods are withdrawn from the borehole, and the soil sampler is replaced with the well point assembly. An appropriate length of Teflon<sup>®</sup> tubing is threaded through the probe rods and attached to the well point. The assembly is lowered into the borehole and then driven down to the target depth and sampling zone. The probe rods are removed, leaving the sacrificial tip, screen assembly and tubing behind. The saturated soil formation is likely to cave in around the screen assembly; where this does not occur, silica sand will be emplaced to create a sand pack around the well point. The borehole annular space around the tubing above the sand pack will be filled with annular seal of granular bentonite or grout.

#### **3.2.2.3.2 Shallow Monitoring Points**

If subsurface conditions permit, shallow monitoring points will be constructed of 0.75-inch OD/0.5-inch ID PVC casing and well screen to provide additional water level information. Approximately 1 meter of factory-slotted screen will be installed for each shallow monitoring point. Effective installation of the shallow monitoring points requires that the boreholes remain open upon completion of drilling. Shallow 0.5-inch ID PVC monitoring points will be installed by punching and sampling a borehole with the Geoprobe<sup>®</sup>. Upon removing the rods, the borehole depth will be measured to determine if

the hole remains open. If the borehole is open, the 0.5-inch ID PVC casing and screen will be placed at the appropriate depths. The annular space around the screen will be filled with sand filter pack, and the annulus around the casing will be filled with grout or bentonite. Monitoring point construction details will be noted on a Monitoring Point Installation Record form (Figure 3.4). This information will become part of the permanent field record for the site.

Temporary monitoring point screens will be constructed of flush-threaded, Schedule 40 PVC with an ID of 0.5 inch. The screens will be factory slotted, with 0.01-inch openings. Monitoring point screens will be placed to sample and provide water level information at or near the water table. Blank monitoring point casing will be constructed of Schedule 40 PVC with an ID of 0.5-inch. All monitoring point casing sections will be flush-threaded; joints will not be glued. The casing at each monitoring point will be fitted with a bottom cap and a top cap constructed of PVC.

If subsurface conditions do not permit the boreholes to stay open (i.e., the formation collapses in the hole), shallow 0.5-inch-ID PVC monitoring points may be installed using the Geoprobe<sup>®</sup>. If the installation of 0.5-inch PVC monitoring points is not possible or is impractical using the Geoprobe<sup>®</sup>, monitoring points constructed of 0.375-inch Teflon<sup>®</sup> (described in Section 3.2.2.3.1) will be utilized. Should 0.5-inch ID PVC shallow monitoring points not be installed, the only data lost will be the water level information for that particular location. The decision to install 0.5-inch ID PVC monitoring points will be made in the field once the open-hole stability of subsurface soils and Geoprobe<sup>®</sup> equipment can be evaluated. The field scientist will verify and record the total depth of the monitoring point, the lengths of all casing sections, and the depth to the top of all monitoring point completion materials. All lengths and depths will be measured to the nearest 0.1 foot.

#### **3.2.2.4 Monitoring Point Completion**

A number of the monitoring points will be completed at or slightly above grade, and steel protective casing will be used to protect the well points from tampering and damage. Where pavement is present, an at-grade cover will be cemented in place using concrete blended into the existing pavement. Where pavement is not present, the protective cover will be raised slightly above the ground surface with a 1-foot square concrete pad that will slope gently away from the cover to facilitate runoff during precipitation events. The number of permanent monitoring points will be determined by the Parsons ES field

# MONITORING POINT INSTALLATION RECORD

JOB NAME GRIFFISS AFB, NEW YORK MONITORING POINT NUMBER \_\_\_\_\_  
 JOB NUMBER 722450.19 INSTALLATION DATE \_\_\_\_\_ LOCATION \_\_\_\_\_  
 DATUM ELEVATION \_\_\_\_\_ GROUND SURFACE ELEVATION \_\_\_\_\_  
 DATUM FOR WATER LEVEL MEASUREMENT \_\_\_\_\_  
 SCREEN DIAMETER & MATERIAL \_\_\_\_\_ SLOT SIZE \_\_\_\_\_  
 RISER DIAMETER & MATERIAL \_\_\_\_\_ BOREHOLE DIAMETER \_\_\_\_\_  
 GEOPROBE CONTRACTOR \_\_\_\_\_ OR \_\_\_\_\_ ES REPRESENTATIVE \_\_\_\_\_

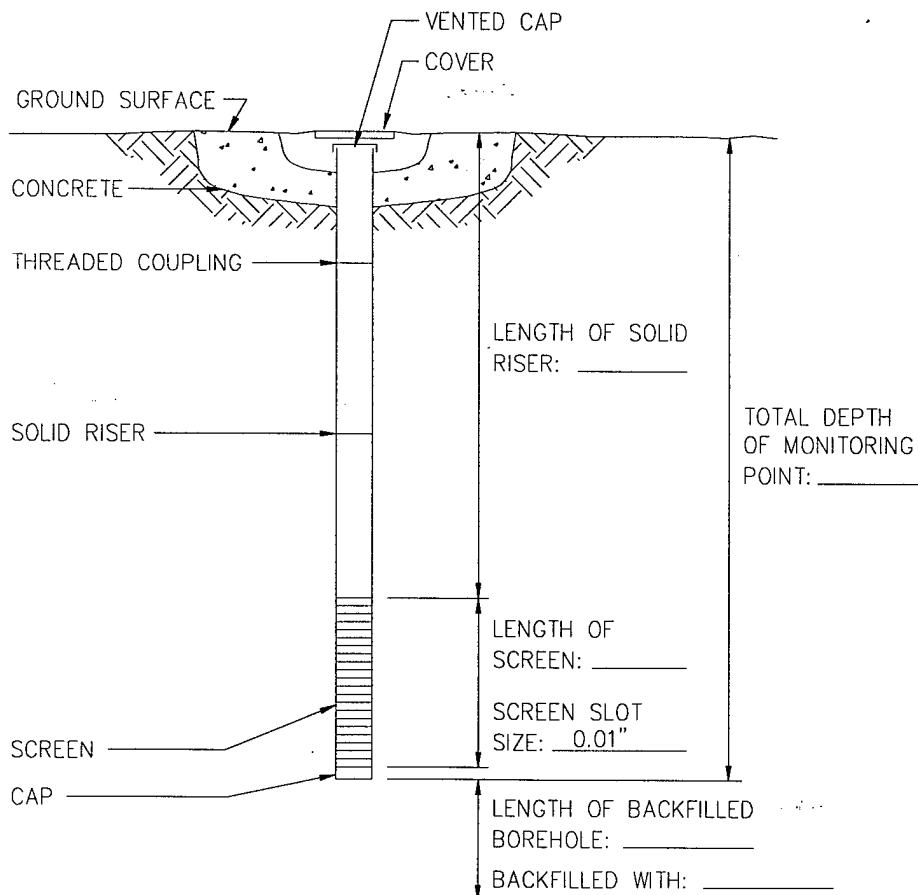

(NOT TO SCALE)

STABILIZED WATER LEVEL \_\_\_\_\_ FEET  
 BELOW DATUM.  
 TOTAL MONITORING POINT DEPTH \_\_\_\_\_ FEET  
 BELOW DATUM.  
 GROUND SURFACE \_\_\_\_\_ FEET

**FIGURE 3.4**

## MONITORING POINT INSTALLATION RECORD

Pumphouse 5  
 Intrinsic Remediation TS  
 Griffiss AFB, New York

**PARSONS**  
**ENGINEERING SCIENCE, INC.**

Denver, Colorado

scientist. The completion of the monitoring points will be similar to those protecting the existing monitoring wells unless otherwise specified by Base personnel.

#### **3.2.2.5 Monitoring Point Abandonment and Site Restoration**

After monitoring point installation and sampling is complete, each site will be restored as closely as possible to its original condition. All contaminated development waters and sampling purge waters not disposed of at the site (headspace readings of > 5 ppmv) will remain in 55-gallon drums provided by the Base until transported by Base personnel to the designated waste collection areas at the Base.

Those monitoring points not completed with an external casing will be abandoned. The PVC casing and screen or Teflon<sup>®</sup> tubing will be extracted as far as possible and discarded. While holes created by the Geoprobe<sup>®</sup> in sandy soils similar to those found at the Base tend to cave in soon after extraction of the drive rod, any test holes remaining open after extraction of the casing will be sealed with bentonite chips, powder, pellets, or grout to eliminate any creation or enhancement of contaminant migration pathways to the groundwater.

#### **3.2.2.6 Monitoring Point Development and Records**

The monitoring points will be developed prior to sampling to remove fine sediments from the portion of the formation adjacent to the well point screen. Development will be accomplished using a peristaltic pump provided by Parsons ES. The pump will be attached to the well point and water will be removed until pH, temperature, specific conductivity, and water clarity (turbidity) stabilize. Monitoring point development will occur a minimum of 24 hours prior to sampling.

Development waters will be collected either in decontamination buckets provided by Parsons ES or 55-gallon barrels provided by Griffiss AFB. A headspace analysis of development waters will be performed by qualified Parsons ES personnel using a portable OVM. Development waters with headspace readings less than 5 ppmv will be disposed of onsite. A shallow disposal pit may be dug to help recharge and aerate disposed rinseate waters onsite (at the discretion of Griffiss AFB personnel). Soils excavated from this disposal pit will be replaced at the end of site characterization activities. Development waters with headspace readings greater than 5 ppmv will be transferred to 55-gallon drums provided by the Base and later transported and disposed of by Base personnel.

A development record will be maintained for each monitoring point. The development record will be completed in the field by the field scientist. Figure 3.5 is an example of a development record used for similar well installations. Development records will include:

- Monitoring point number;
- Date and time of development;
- Development method;
- Monitoring point depth;
- Volume of water produced;
- Description of water produced;
- Post-development water level and monitoring point depth; and
- Field analytical measurements, including pH and specific conductivity.

### **3.2.3 Groundwater Grab Sampling Procedures**

The sampling depth and interval will be specified prior to driving the Geoprobe<sup>®</sup> pushrod into the ground. The Parsons ES field scientist will verify the sampling depth by measuring the length of each pushrod prior to insertion into the ground. A drive tip fitted with a slotted steel screen will be placed on the tip of the pushrod, and the rod will be pushed into the ground using the Geoprobe<sup>®</sup> apparatus. After reaching the desired depth, the pushrod will be raised 1 to 2 feet to expose the screen and to allow water to percolate into the end of the hollow pushrod. Water samples will be collected from water entering the downhole, slotted end of the pushrod through the screen with a peristaltic pump. The groundwater sample will be acquired as described in Section 3.3.2.

### **3.2.4 Monitoring Point Location and Datum Survey**

The location and elevation of the well points will be surveyed soon after completion. The horizontal location will be measured relative to established Base coordinates. Horizontal coordinates will be measured to the nearest 0.1 foot. The elevation of the ground surface adjacent to the protective casing will be measured relative to the USGS msl datum. The ground surface elevation will be measured to the nearest 0.1 foot. Because water levels cannot be measured through the well point tubing, no datum elevation, such as top of casing, will be measured.

# MONITORING POINT DEVELOPMENT RECORD

Page\_\_ of\_\_

Job Number: 722450.19

Job Name: Griffiss AFB, New York

Location: \_\_\_\_\_

By \_\_\_\_\_

Date \_\_\_\_\_

Well Number \_\_\_\_\_

Measurement Datum \_\_\_\_\_

## Pre-Development Information

Time (Start): \_\_\_\_\_

Water Level: \_\_\_\_\_

Total Depth of Well: \_\_\_\_\_

### Water Characteristics

Color \_\_\_\_\_ Clear Cloudy  
Odor: None Weak Moderate Strong  
Any Films or Immiscible Material \_\_\_\_\_  
pH \_\_\_\_\_ Temperature(<sup>o</sup>F <sup>o</sup>C) \_\_\_\_\_  
Specific Conductance( $\mu$ S/cm) \_\_\_\_\_

## Interim Water Characteristics

Gallons Removed \_\_\_\_\_

pH \_\_\_\_\_

Temperature (<sup>o</sup>F <sup>o</sup>C) \_\_\_\_\_

Specific Conductance( $\mu$ S/cm) \_\_\_\_\_

## Post-Development Information

Time (Finish): \_\_\_\_\_

Water Level: \_\_\_\_\_

Total Depth of Well: \_\_\_\_\_

Approximate Volume Removed: \_\_\_\_\_

### Water Characteristics

Color \_\_\_\_\_ Clear Cloudy  
Odor: None Weak Moderate Strong  
Any Films or Immiscible Material \_\_\_\_\_  
pH \_\_\_\_\_ Temperature(<sup>o</sup>F <sup>o</sup>C) \_\_\_\_\_  
Specific Conductance( $\mu$ S/cm) \_\_\_\_\_

Comments: \_\_\_\_\_

### FIGURE 3.5

## MONITORING POINT DEVELOPMENT RECORD

Pumphouse 5  
Intrinsic Remediation TS  
Griffiss AFB, New York



**PARSONS  
ENGINEERING SCIENCE, INC.**

Denver, Colorado

### 3.2.5 Water Level Measurements

Water levels at monitoring wells and monitoring points will be measured (where possible) within a short time period so that the water level data are comparable. The depth to water below the measurement datum will be measured to the nearest 0.01 foot using an electric water level probe.

### 3.3 Groundwater Sampling

This section describes the scope of work required for collection of groundwater quality samples. Samples will be collected from existing monitoring wells (i.e., wells 771MW-1 through 771MW-9), newly installed groundwater monitoring points, and grab sample locations. A peristaltic pump with dedicated tubing will be used to collect groundwater samples. In order to maintain a high degree of QC during this sampling event, the procedures described in the following sections will be followed.

Sampling will be conducted by qualified scientists and technicians from Parsons ES who are trained in the conduct of groundwater sampling, records documentation, and chain-of-custody procedures. In addition, sampling personnel will have thoroughly reviewed this work plan prior to sample acquisition and will have a copy of the work plan available onsite for reference. The following activities will occur during groundwater sampling:

- Assembly and preparation of equipment and supplies;
- Inspection of the monitoring well/point integrity including:
  - Protective cover, cap, and lock,
  - External surface seal and pad,
  - Monitoring point stick-up, cap, and datum reference, and
  - Internal surface seal;
- Groundwater sampling, including
  - Water level and product thickness measurements,
  - Visual inspection of sample water,
  - Monitoring point casing evacuation, and

- Sample collection;
- Sample preservation and shipment, including
  - Sample preparation,
  - Onsite measurement of physical parameters, and
  - Sample labeling;
- Completion of sampling records: and
- Sample disposition.

Detailed groundwater sampling and sample handling procedures are presented in following sections.

### **3.3.1 Preparation for Sampling**

All equipment to be used for sampling will be assembled and properly cleaned and calibrated (if required) prior to arriving in the field. In addition, all record-keeping materials will be gathered prior to leaving the office.

#### **3.3.1.1 Equipment Cleaning**

All portions of sampling and test equipment that will contact the sample matrix will be thoroughly cleaned before each use. This includes the Geoprobe<sup>®</sup> soil sampling tool, water level probe and cable, lifting line, test equipment for onsite use, and other equipment or portions thereof that will contact the samples. Based on the types of sample analyses to be conducted, the following cleaning protocol will be used:

- Wash with potable water and phosphate-free laboratory detergent (HP-II detergent solutions, as appropriate);
- Rinse with potable water;
- Rinse with isopropyl alcohol;
- Rinse with distilled or deionized water; and
- Air dry the equipment prior to use.

Any deviations from these procedures will be documented in the field scientist's field notebook and on the groundwater sampling record (Figure 3.6).

If precleaned disposable sampling equipment is used, the cleaning protocol specified above will not be required. Laboratory-supplied sample containers will be cleaned and

# GROUNDWATER SAMPLING RECORD

SAMPLING LOCATION \_\_\_\_\_  
SAMPLING DATE(S) \_\_\_\_\_  
MONITORING WELL \_\_\_\_\_  
(number)

REASON FOR SAMPLING:  Regular Sampling;  Special Sampling;  
DATE AND TIME OF SAMPLING: \_\_\_\_\_, 19\_\_\_\_ a.m./p.m.  
SAMPLE COLLECTED BY: \_\_\_\_\_ of \_\_\_\_\_  
WEATHER: \_\_\_\_\_  
DATUM FOR WATER DEPTH MEASUREMENT (Describe): \_\_\_\_\_

## MONITORING WELL CONDITION:

LOCKED:  UNLOCKED

WELL NUMBER (IS - IS NOT) APPARENT \_\_\_\_\_

STEEL CASING CONDITION IS: \_\_\_\_\_

INNER PVC CASING CONDITION IS: \_\_\_\_\_

WATER DEPTH MEASUREMENT DATUM (IS - IS NOT) APPARENT \_\_\_\_\_

DEFICIENCIES CORRECTED BY SAMPLE COLLECTOR

MONITORING WELL REQUIRED REPAIR (describe): \_\_\_\_\_

## Check-off

1  EQUIPMENT CLEANED BEFORE USE WITH \_\_\_\_\_  
Items Cleaned (List): \_\_\_\_\_

2  PRODUCT DEPTH \_\_\_\_\_ FT. BELOW DATUM  
Measured with: \_\_\_\_\_

WATER DEPTH \_\_\_\_\_ FT. BELOW DATUM  
Measured with: \_\_\_\_\_

3  WATER-CONDITION BEFORE WELL EVACUATION (Describe):  
Appearance: \_\_\_\_\_  
Odor: \_\_\_\_\_  
Other Comments: \_\_\_\_\_

4  WELL EVACUATION:  
Method: \_\_\_\_\_  
Volume Removed: \_\_\_\_\_  
Observations: Water (slightly - very) cloudy  
Water level (rose - fell - no change)  
Water odors: \_\_\_\_\_  
Other comments: \_\_\_\_\_

## FIGURE 3.6

### GROUNDWATER SAMPLING RECORD

Pumphouse 5  
Intrinsic Remediation TS  
Griffiss AFB, New York



**PARSONS  
ENGINEERING SCIENCE, INC.**

Denver, Colorado



sealed by the laboratory. The type of container provided and the method of container decontamination will be documented in the permanent record of the sampling event.

### **3.3.1.2 Equipment Calibration**

As required, field analytical equipment will be calibrated according to the manufacturers' specifications prior to field use. This applies to equipment used for onsite measurements of DO, pH, electrical conductivity, temperature, redox potential, sulfate, nitrate, ferrous iron ( $\text{Fe}^{2+}$ ), and other field parameters listed on Table 3.1.

### **3.3.2 Sampling Procedures**

Special care will be taken to prevent contamination of the groundwater and extracted samples. The two primary ways in which sample contamination can occur are through contact with improperly cleaned equipment and through cross-contamination due to insufficient cleaning of equipment between wells and monitoring points. To prevent such contamination, the water level probe and cable used to determine static water levels and total well depths will be thoroughly cleaned before and after field use and between uses at different sampling locations according to the procedures presented in Section 3.3.1.1. Dedicated tubing will be used at each well or monitoring point developed, purged, and/or sampled with the peristaltic pump. Dedicated, disposable bailers may be used on the 2-inch ID existing wells. Any nondisposable bailers will be decontaminated according to procedures listed in Section 3.3.1.1. In addition to the use of properly cleaned equipment, a clean pair of new, disposable nitrile or latex gloves will be worn each time a different well or monitoring point is sampled. The following paragraphs present the procedures to be followed for groundwater sample collection from groundwater monitoring wells and monitoring points. These activities will be performed in the order presented below. Exceptions to this procedure will be noted in the field scientist's field notebook.

#### **3.3.2.1 Preparation of Location**

Prior to starting the sampling procedure, the area around the existing wells and new monitoring points will be cleared of foreign materials, such as brush, rocks, and debris. These procedures will prevent sampling equipment from inadvertently contacting debris around the monitoring well/point.

#### **3.3.2.2 Water Level and Total Depth Measurements**

Prior to removing any water from the monitoring well or monitoring point, the static water level will be measured. An electric water level probe will be used to measure the

depth to groundwater below the datum to the nearest 0.01 foot. After measuring the static water level, the water level probe will be slowly lowered to the bottom of the monitoring well/point and the depth will be measured to the nearest 0.01 foot. If free-phase product (LNAPL) is present, the total depth of the well from installation records will be used to avoid excessive contamination of the water level probe and cord. Based on these measurements, the volume of water to be purged from the monitoring well/point will be calculated. If free-phase product is encountered, the thickness of the product will be measured with an oil/water interface probe.

### **3.3.2.3 Monitoring Well/Point Purging**

The volume of water contained within the monitoring well/point casing at the time of sampling will be calculated, and three times the calculated volume will be removed from the well/point. A peristaltic pump will be used for monitoring well and monitoring point purging, depth permitting, and either a Waterra<sup>®</sup> inertial pump or a bailer will be used to purge all monitoring points in which a peristaltic pump will not work. All purge water will be collected either in a decontamination pit or in buckets provided by Parsons ES. A headspace analysis of collected purge water will be performed by qualified Parsons ES personnel with a portable OVM. Purge waters with headspace readings less than 5 ppmv will be disposed of onsite. A shallow, disposal pit may be dug to help recharge and aerate disposed purge waters onsite (at the discretion of Griffiss AFB personnel). Soils excavated from this disposal pit will be replaced at the end of site-characterization activities. Purge waters with headspace readings greater than 5 ppmv will be transferred to 55-gallon drums provided by the Base and later transported and disposed of by Base personnel.

If a monitoring well/point is evacuated to a dry state during purging, the monitoring well/point will be allowed to recharge, and the sample will be collected as soon as sufficient water is present in the monitoring well/point to obtain the necessary sample quantity. Sample compositing or sampling over a lengthy period by accumulating small volumes of water at different times to obtain a sample of sufficient volume will not be allowed.

### **3.3.2.4 Sample Extraction**

Dedicated high-density polyethylene (HDPE) tubing and a peristaltic pump will be used to extract groundwater samples from monitoring wells/points whenever depth to groundwater permits; otherwise, a Waterra<sup>®</sup> inertial pump or bailer will be used. A

peristaltic pump will be used to extract groundwater samples from the grab sampling locations. Prior to sample collection, groundwater will be purged until dissolved oxygen and temperature readings have stabilized. The tubing, pump, or bailer will be lowered through the casing into the water gently to prevent splashing. The sample will be transferred directly into the appropriate sample container. The water will be carefully poured down the inner walls of the sample bottle to minimize aeration of the sample.

Sample containers will be completely filled so that no air space remains in the container. Excess water collected during sampling will be collected, analyzed, and disposed of as outlined in Section 3.3.2.3.

### **3.3.3 Onsite Groundwater Parameter Measurement**

As indicated in Table 3.1, many of the groundwater chemical parameters will be measured onsite by Parsons ES staff. Some of the measurements will be made with direct-reading meters, while others will be made using a HACH® portable colorimeter in accordance with specific HACH® analytical procedures. These procedures are described in the following subsections.

All glassware or plasticware used in the analyses will have been cleaned prior to sample collection by thoroughly washing with a solution of Alconox® and water, and rinsing with isopropyl alcohol and deionized water to prevent interference or cross-contamination between measurements. If concentrations of an analyte are above the range detectable by the titrimetric method, the analysis will be repeated by diluting the groundwater sample with double-distilled water until the analyte concentration falls to a level within the range of the method. All rinseate and sample reagents accumulated during groundwater analysis will be collected in glass containers fitted with screw caps. These waste containers will be clearly labeled as to their contents and carefully stored for later transfer by Base personnel to the approved disposal facility.

#### **3.3.3.1 Dissolved Oxygen Measurements**

DO measurements will be made before and immediately following groundwater sample acquisition using a meter with a downhole oxygen sensor or a sensor in a flow-through cell. When DO measurements are taken in monitoring wells/points that have not yet been sampled, the existing monitoring wells/points will be purged until DO levels stabilize.

### **3.3.3.2 pH, Temperature, Redox, and Specific Conductance**

Because the pH, temperature, oxidation/reduction (redox) potential, and specific conductance of a groundwater sample can change significantly within a short time following sample acquisition, these parameters will be measured in the field in unfiltered, unpreserved, "fresh" water collected by the same technique as the samples taken for laboratory analyses. The measurements will be made in a flow-through cell or a clean glass container separate from those intended for laboratory analysis, and the measured values will be recorded in the groundwater sampling record (Figure 3.6).

### **3.3.3.3 Alkalinity Measurements**

Alkalinity in groundwater helps buffer the groundwater system against acids generated through both aerobic and anaerobic biodegradation processes. Alkalinity of the groundwater sample will be measured in the field by experienced Parsons ES scientists via titrimetric analysis using EPA-approved HACH® Method 8221 (0 to 5,000 mg/L as calcium carbonate) or a similar method. Alkalinity of the groundwater sample will also be measured in the laboratory using EPA Method 310.1.

### **3.3.3.4 Nitrate- and Nitrite-Nitrogen Measurements**

Nitrate-nitrogen concentrations are of interest because nitrate can act as an electron acceptor during hydrocarbon biodegradation under anaerobic soil or groundwater conditions. Nitrate-nitrogen is also a potential nitrogen source for biomass formation for hydrocarbon-degrading bacteria. Nitrite-nitrogen is an intermediate byproduct in both ammonia nitrification and in nitrate reduction in anaerobic environments.

Nitrate- and nitrite-nitrogen concentrations in groundwater will be measured in the field by experienced Parsons ES scientists via colorimetric analysis using a HACH® DR/700 Portable Colorimeter. Nitrate concentrations in groundwater samples will be analyzed after preparation with HACH® Method 8039 (0 to 30.0 mg/L NO<sub>3</sub>). Nitrite concentrations in groundwater samples will be analyzed after preparation with EPA-approved HACH® Method 8507 (0 to 0.35 mg/L NO<sub>2</sub>) or a similar method. Nitrate and nitrite-nitrogen samples will also be analyzed by the analytical laboratory using EPA method 353.1.

### **3.3.3.5 Carbon Dioxide Measurements**

Carbon dioxide concentrations in groundwater will be measured in the field by Parsons ES scientists via titrimetric analysis using HACH® Method 8223 (0 to 250 mg/L as CO<sub>2</sub>).

Sample preparation and disposal procedures are the same as outlined at the beginning of Section 3.3.3.

#### **3.3.3.6 Sulfate and Sulfide Sulfur Measurements**

Sulfate in groundwater is a potential electron acceptor for fuel-hydrocarbon biodegradation in anaerobic environments, and sulfide is resultant after sulfate reduction. A Parsons ES scientist will measure sulfate and sulfide concentrations via colorimetric analysis with a HACH® DR/700 Portable Colorimeter after appropriate sample preparation. EPA-approved HACH® Methods 8051 (0 to 70.0 mg/L SO<sub>4</sub>) or similar and 8131 (0.60 mg/L S<sup>2-</sup>) or similar will be used to prepare samples and analyze sulfate and sulfide concentrations, respectively. Sulfate concentrations will also be analyzed by the analytical laboratory using methods E300 or SW9056.

#### **3.3.3.7 Total Iron, Ferrous Iron, and Ferric Iron Measurements**

Iron is an important trace nutrient for bacterial growth, and different states of iron can affect the redox potential of the groundwater and act as an electron acceptor for biological metabolism under anaerobic conditions. Iron concentrations will be measured in the field via colorimetric analysis with a HACH® DR/700 Portable Colorimeter after appropriate sample preparation. HACH® Method 8008 (or similar) for total soluble iron (0 to 3.0 mg/L Fe<sup>3+</sup> + Fe<sup>2+</sup>) and HACH® Method 8146 (or similar) for ferrous iron (0 to 3.0 mg/L Fe<sup>2+</sup>) will be used to prepare and quantitate the samples. Ferric iron will be quantitated by subtracting ferrous iron levels from total iron levels.

#### **3.3.3.8 Manganese Measurements**

Manganese is a potential electron acceptor under anaerobic environments. Manganese concentrations will be quantitated in the field using colorimetric analysis with a HACH® DR/700 Portable Colorimeter. EPA-approved HACH® Method 8034 (0 to 20.0 mg/L) or similar will be used for quantitation of manganese concentrations. Sample preparation and disposal procedures are outlined earlier in Section 3.3.3.

#### **3.3.3.9 Redox Potential**

The redox potential of groundwater is an indication of the relative tendency of a solution to accept or transfer electrons. Redox reactions in groundwater are usually biologically mediated; therefore, the redox potential of a groundwater system depends upon and influences rates of biodegradation. Redox potential can be used to provide real-time data on the location of the contaminant plume, especially in areas undergoing

anaerobic biodegradation. The redox potential of a groundwater sample taken inside the contaminant plume should be somewhat less than that taken upgradient or cross-gradient from the plume.

The redox potential of a groundwater sample can change significantly within a short time following sample acquisition and exposure to atmospheric oxygen. Therefore, this parameter will be measured in the field in a flow-through cell or in unfiltered, unpreserved, "fresh" water collected by the same technique as the samples taken for laboratory analyses. The measurements will be made as quickly as possible in a clean glass container separate from those intended for laboratory analysis.

### **3.4 Sample Handling for Laboratory Analysis**

This section describes the handling of samples from the time of sampling until the samples are delivered to the fixed-base laboratory. For this study, Evergreen Analytical Laboratories, Inc. (EAL) of Wheatridge, Colorado will provide analytical laboratory support.

#### **3.4.1 Sample Preservation**

All necessary sample containers will be provided by the laboratory and necessary chemical preservatives will be pre-placed in the sample containers. Samples will be prepared for transportation to EAL by placing the samples in a cooler containing ice to maintain a shipping temperature of 4 degrees centigrade (°C). Samples will be delivered to the analytical laboratory via overnight courier so that all sample holding times are met.

#### **3.4.2 Sample Container and Labels**

Sample containers and appropriate container lids will be provided by the laboratory (see Appendix A). The sample containers will be filled as described in Section 3.3.3.2.4, and the container lids will be tightly closed. The sample label will be firmly attached to the container side, and the following information will be legibly and indelibly written on the label:

- Facility name;
- Sample identification;
- Sample type (e.g., groundwater, soil);
- Sampling date;
- Sampling time;

- Preservatives added;
- Sample collector's initials; and
- Requested analyses.

### **3.4.3 Sample Shipment**

After the samples are sealed and labeled, they will be packaged for transport to the laboratory. The following packaging and labeling procedures will be followed:

- Package sample so that it will not leak, spill, or vaporize from its container;
- Cushion samples to avoid breakage; and
- Add ice to container to keep samples cool.

The packaged samples will be delivered by overnight courier to the analytical laboratory. Delivery will occur as soon as possible after sample acquisition.

### **3.4.4 Chain-of-Custody Control**

After the samples have been collected, chain-of-custody procedures will be followed to establish a written record of sample handling and movement between the sampling site and the analytical laboratory. Each shipping container will have a chain-of-custody form completed in triplicate by the sampling personnel. One copy of this form will be kept by the sampling contractor after sample deliver to the analytical laboratory, and the other two copies will become a part of the permanent record for the sample and will be returned with the sample analytical results. The chain-of-custody will contain the following information:

- Sample identification number;
- Sample collectors' printed names and signatures;
- Date and time of collection;
- Place and address of collection;
- Sample matrix;
- Chemical preservatives added;
- Analyses requested;
- Signatures of individuals involved in the chain of possession; and

- Inclusive dates of possession.

The chain-of-custody documentation will be placed inside the shipping container so that it will be immediately apparent to the laboratory personnel receiving the container, but will not be damaged or lost during transport. The shipping container will be sealed so that it will be obvious if the seal has been tampered with or broken.

### **3.4.5 Sampling Records**

In order to provide complete documentation of the sampling event, detailed records will be maintained by the field scientist. At a minimum, these records will include the following information:

- Sample location (facility name);
- Sample identification;
- Sample location map or detailed sketch;
- Date and time of sampling;
- Sampling method;
- Field observations of
  - Sample appearance, and
  - Sample odor;
- Weather conditions;
- Water level prior to purging (groundwater samples, only);
- Total monitoring well/point depth (groundwater samples, only);
- Sample depth (soil samples, only);
- Purge volume (groundwater samples, only);
- Water level after purging (groundwater samples, only);
- Monitoring well/point condition (groundwater samples, only);
- Sampler's identification;
- Field measurements of pH, temperature, DO, and specific conductivity (groundwater samples, only); and
- Any other relevant information.

Groundwater sampling information will be recorded on a groundwater sampling form. Figure 3.6 is an example of the groundwater sampling record. Soil sampling information will be recorded in the field log book.

### **3.4.6 Laboratory Analyses**

Laboratory analyses will be performed on all groundwater and soil samples and the QA/QC samples described in Section 5. The analytical methods for this sampling event are listed in Table 3.1. Prior to sampling, arrangements will be made with the analytical laboratory to provide a sufficient number of analyte-appropriate sample containers for the samples to be collected. All containers, preservatives, and shipping requirements will be consistent with EPA protocol or those reported in Appendix A of this plan.

EAL personnel will specify the necessary QC samples and prepare appropriate QC sample bottles. For samples requiring chemical preservation, preservatives will be added to containers by EAL. Containers, ice chests with adequate padding, and cooling media may be sent by the laboratory to the site. Sampling personnel will fill the sample containers and return the samples to the mobile laboratory.

### **3.5 Aquifer Testing**

Slug tests will be conducted on selected existing wells to estimate the hydraulic conductivity of unconsolidated sand and clay deposits at the site. This information is required to accurately estimate the velocity of groundwater and contaminants in the shallow saturated zone. A slug test is a single-well hydraulic test used to determine the hydraulic conductivity of an aquifer in the immediate vicinity of the tested well. Slug tests can be used for both confined and unconfined aquifers that have a transmissivity of less than 7,000 square feet per day ( $\text{ft}^2/\text{day}$ ). Slug testing can be performed using either a rising head or a falling head test; at this site, both methods will be used in sequence.

#### **3.5.1 Definitions**

**Hydraulic Conductivity (K).** A quantitative measure of the ability of porous material to transmit water; defined as the volume of water that will flow through a unit cross-sectional area of porous or fractured material per unit time under a unit hydraulic gradient.

**Transmissivity (T).** A quantitative measure of the ability of an aquifer to transmit water. It is the product of the hydraulic conductivity and the saturated thickness.

**Slug Test.** Two types of testing are possible: rising head and falling head tests. A slug test consists of adding a slug of water or a solid cylinder of known volume to the well to be tested or removing a known volume of water or cylinder and measuring the rate of recovery of water level inside the well. The slug of a known volume acts to raise or lower the water level in the well.

**Rising Head Test.** A test used in an individual well within the saturated zone to estimate the hydraulic conductivity of the surrounding formation by lowering the water level in the well and measuring the rate of recovery of the water level. The water level may be lowered by pumping, bailing, or removing a submerged slug from the well.

**Falling Head Test.** A test used in an individual well to estimate the hydraulic conductivity of the surrounding formation by raising the water level in the well by insertion of a slug or quantity of water, and then measuring the rate of drop in the water level.

### **3.5.2 Equipment**

The following equipment will be used to conduct a slug test:

- Teflon<sup>®</sup>, PVC, or metal slugs;
- Nylon or polypropylene rope;
- Electric water level indicator;
- Pressure transducer/sensor;
- Field logbook/forms; and
- Automatic data recording instrument (such as the Hermit Environmental Data Logger<sup>®</sup>, In-Situ, Inc. Model SE1000B, or equivalent.)

### **3.5.3 General Test Methods**

Aquifer hydraulic conductivity tests (slug tests) are accomplished by either removal of a slug or quantity of water (rising head) or introduction of a slug (falling head), and then allowing the water level to stabilize while taking water level measurements at closely spaced time intervals.

Because hydraulic testing will be completed on existing wells, it will be assumed that the wells were properly developed and that water levels have stabilized. Slug testing will proceed only after multiple water level measurements over time show that static water

levels are in equilibrium. During the slug test, the water level change should be influenced only by the introduction (or removal) of the slug volume. Other factors, such as inadequate well development or extended pumping may lead to inaccurate results; slug tests will not be performed on wells with free product. The field scientist will determine when static equilibrium has been reached in the well. The pressure transducer, slugs, and any other downhole equipment will be decontaminated prior to and immediately after the performance of each slug test using the procedures described in Section 3.3.1.1.

#### **3.5.4 Falling Head Test**

The falling head test is the first step in the two-step slug testing procedure. The following paragraphs describe procedures to be followed during performance of the falling head test.

1. Decontaminate all downhole equipment prior to initiating the test.
2. Open the well. Where wells are equipped with water tight caps, the well should be unsealed at least 24 hours prior to testing to allow the water level to stabilize. The protective casing will remain locked during this time to prevent vandalism.
3. Prepare the aquifer slug test data form (Figure 3.7) with entries for:
  - Borehole/well number,
  - Project number,
  - Project name,
  - Aquifer testing team,
  - Climatic data,
  - Ground surface elevation,
  - Top of well casing elevation,
  - Identification of measuring equipment being used,
  - Page number,
  - Static water level, and
  - Date.
4. Measure the static water level in the well to the nearest 0.01 foot.



5. Lower the decontaminated pressure transducer into the well and allow the displaced water to return to its static level. This can be determined by periodic water level measurements until the static water level in the well is within 0.01 foot of the original static water level.
6. Lower the decontaminated slug into the well to just above the water level in the well.
7. Turn on the data logger and quickly lower the slug below the water table, being careful not to disturb the pressure transducer. Follow the owner's manual for proper operation of the data logger.
8. Terminate data recording when the water level stabilizes in the well. The well will be considered stabilized for termination purposes when it has recovered 80 to 90 percent from the initial displacement.

#### **3.5.5 Rising Head Test**

After completion of the falling head test, the rising head test will be performed. The following paragraphs describe the rising head slug test procedure.

1. Measure the water level in the well to the nearest 0.01 foot to ensure that it has returned to the static water level.
2. Initiate data recording and quickly withdraw the slug from the well. Follow the owner's manual for proper operation of the data logger.
3. Terminate data recording when the water level stabilizes in the well, and remove the pressure transducer from the well and decontaminate. The well will be considered stabilized for termination purposes when it has recovered 80 to 90 percent from the initial displacement.

#### **3.5.6 Slug Test Data Analysis**

Data obtained during slug testing will be analyzed using AQTESOLV™ and the method of Hvorslev (1951) for confined aquifers or the method of Bouwer and Rice (1976) and Bouwer (1989) for unconfined conditions.

## SECTION 4

### REMEDIAL OPTION EVALUATION AND TS REPORT

Upon completion of field work, the Bioplume II numerical groundwater model will be used to determine the fate and transport of fuel hydrocarbons dissolved in groundwater at the site. Based upon model predictions of contaminant concentration and distribution through time, and upon potential exposure pathways, the potential risk to human health and the environment will be assessed. If it is shown that intrinsic remediation of BTEX compounds at the site is sufficient to reduce the potential risk to human health and the environment to acceptable levels (e.g., state groundwater standards), Parsons ES will recommend implementation of the intrinsic remediation option. If intrinsic remediation is chosen, Parsons ES will prepare a site-specific, long-term monitoring plan that will specify the location of point-of-compliance monitoring wells and sampling frequencies.

If the intrinsic remediation remedial option is deemed inappropriate for use at this site, institutional controls such as groundwater or land use restrictions will be evaluated to determine if they will be sufficient to reduce the risk to human health and the environment to acceptable levels. If institutional controls are inappropriate, remedial options which could reduce risks to acceptable levels will be evaluated and the most appropriate remedial options will be recommended. Potential remedial options include, but are not limited to, free product recovery, groundwater pump and treat, enhanced biological treatment, bioventing, bioslurping, and *in situ* reactive barrier walls. The reduction in dissolved BTEX that should result from remedial activities will be used to produce a new input file for the Bioplume II model. The model will then be used to predict the BTEX plume (and risk) reduction that should result from remedial actions.

Upon completion of Bioplume II modeling and remedial option selection, a TS report detailing the results of the modeling and remedial option selection will be prepared. This report will follow the outline presented in Table 4.1 and will contain an introduction, site descriptions, identification of remediation objectives, description of remediation alternatives, an analysis of remediation alternatives, and the recommended remedial approach for each site. This report will also contain the results of the site characterization activities described herein and a description of the Bioplume II model developed for this site.

**TABLE 4.1**  
**EXAMPLE TS REPORT OUTLINE**  
**PUMPHOUSE 5**  
**INTRINSIC REMEDIATION TS**  
**GRIFFISS AFB, NEW YORK**

---

**INTRODUCTION**

**SITE DESCRIPTION**

- Drilling, Soil Sampling, and Monitoring Well Installation
- Groundwater Sampling
- Aquifer Testing
- Surveying

**PHYSICAL CHARACTERISTICS OF THE STUDY AREA**

- Surface Features
- Regional Geology and Hydrogeology
- Site Geology and Hydrogeology

**NATURE AND EXTENT OF CONTAMINATION**

- Source of Contamination
- Soil Chemistry
- Groundwater Chemistry

**GROUNDWATER MODEL**

- General Overview and Model Description
- Conceptual Model Design and Assumptions
- Initial Model Setup
- Model Calibration
- Sensitivity Analysis
- Model Results
- Conclusions and Discussion

**COMPARATIVE ANALYSIS OF REMEDIAL ALTERNATIVES**

- Remedial Alternative Evaluation Criteria
- Factors Influencing Alternatives Development
- Brief Description of Remedial Alternatives
- Evaluation of Alternatives
- Recommended Remedial Approach

**LONG-TERM MONITORING PLAN**

- Overview
- Monitoring Networks for Groundwater
- Groundwater Sampling

**CONCLUSIONS AND RECOMMENDATIONS**

**REFERENCES**

**APPENDICES**

## SECTION 5

### QUALITY ASSURANCE/QUALITY CONTROL

Field QA/QC procedures will include collection of field duplicates and rinseate, field and trip blanks; decontamination of all equipment contacts that the sample medium before and after each use; use of analyte-appropriate containers; and chain-of-custody procedures for sample handling and tracking. All samples to be transferred to the analytical laboratory for analysis will be clearly labeled to indicate sample number, location, matrix (e.g., groundwater), and analyses requested. Samples will be preserved in accordance with the analytical methods to be used, and water sample containers will be packaged in coolers with ice to maintain a temperature of 4°C.

All field sampling activities will be recorded in a bound, sequentially paginated field notebook in permanent ink. All sample collection entries will include the date, time, sample locations and numbers, notations of field observations, and the sampler's name and signature. Field QC samples will be collected in accordance with the program described below, and as summarized in Table 5.1.

QA/QC sampling will include collection and analysis of duplicate groundwater and soil samples, rinseate blanks, field/trip blanks, and matrix spike samples. Internal laboratory QC analyses will involve the analysis of laboratory control samples (LCSs) and laboratory method blanks (LMBs). QA/QC objectives for each of these samples, blanks, and spikes are described below.

Soil and groundwater samples collected with the Geoprobe sampler should provide sufficient volume for some duplicate analyses. Refer to Table 3.1 and Appendix A for further details on sample volume requirements.

One rinseate samples will be collected for every 20 or fewer groundwater samples collected from existing wells and newly installed monitoring points. Because disposable bailers may be used for this sampling event, the rinseate sample may consist of a sample of distilled water poured into a new disposable bailer and subsequently transferred into a sample container provided by the laboratory. Rinseate samples will be analyzed for VOCs only.

**TABLE 5.1**  
**QA/QC SAMPLING PROGRAM**  
**PUMPHOUSE 5**  
**INTRINSIC REMEDIATION TS**  
**GRIFFISS AFB, NEW YORK**

QA/QC Sample Types	Frequency to be Collected and/or Analyzed	Analytical Methods
Duplicates/Replicates	Every 9 Groundwater and 9 Soil Samples (10%)	VOCs, TPH
Rinseate Blanks	Every 20 Groundwater samples	VOCs
Field Blanks	Every 20 Groundwater samples	VOCs
Trip Blanks	One per shipping cooler containing VOC samples	VOCs
Matrix Spike Samples	Once per sampling event	VOCs
Laboratory Control Sample	Once per method per medium	Laboratory Control Charts (Method Specific)
Laboratory Method Blanks	Once per method per medium	Laboratory Control Charts (Method Specific)

A field blank will be collected for every 20 or fewer groundwater samples (both from groundwater monitoring point and existing groundwater monitoring well sampling events) to assess the effects of ambient conditions in the field. The field blank will consist of a sample of distilled water poured into a laboratory-supplied sample container while sampling activities are underway. The field blank will be analyzed for VOCs.

A trip blank will be analyzed to assess the effects of ambient conditions on sampling results during the transportation of samples. The trip blank will be prepared by the laboratory. A trip blank will be transported inside each cooler which contains samples for VOC analysis. Trip blanks will be analyzed for VOCs.

Matrix spikes will be prepared in the laboratory and used to establish matrix effects for samples analyzed for VOCs.

LCSs and LMBs will be prepared internally by the laboratory and will be analyzed each day samples from the site are analyzed. Samples will be reanalyzed in cases where the LCS or LMB are out of the control limits. Control charts for LCSs and LMBs will be developed by the laboratory and monitored for the analytical methods used.

## SECTION 6

### REFERENCES

- ATSDR, 1988, Health Assessment for Griffiss Air Force Base, Rome, New York; Albany, New York: Department of Health and Human Services Agency for Toxic Substances and Diseases Registry (ATSDR), June 9.
- Bouwer, H., 1989, The Bouwer and Rice slug test - an update: *Groundwater*, 27(3), p. 304-309.
- Bouwer, H., and Rice, R.C., 1976, A slug test for determining hydraulic conductivity of unconfined aquifers with completely or partially penetrating wells: *Water Resources Research*, 12(3), p. 423-428.
- Bruce, L., Miller, T., and Hockman, B., 1991, Solubility versus equilibrium saturation of gasoline compounds - a method to estimate fuel/water partition coefficient using solubility or  $K_{oc}$ . In, A. Stanley (editor), NWWAI/API Conference on Petroleum Hydrocarbons in Groundwater: NWT/API, p. 571-582.
- Casey and Reynolds, 1989 (Awaiting Reference)
- Cline, P.V., Delfino, J.J., and Rao, P.S.C., 1991, Partitioning of aromatic constituents into water from gasoline and other complex solvent mixtures: *Environmental Science and Technology*: v. 17, no. 4, p. 227-231.
- Engineering-Science, Inc. (ES), 1993, Health and Safety Plan for the Bioplume Modeling Initiative, Prepared for the Air Force Center for Environmental Excellence, Environmental Restoration Division, USAF Contract F41624-92-D-8036.
- Fenneman, N.M., 1938, Physiography of the Eastern United States, McGraw-Hill Book Company, New York and London.
- Fisher, D.W., Isachsen, Y.W., and L.V. Rickard, 1970, Geologic Map of New York - Hudson-Mohawk Sheet, New York State Museum and Science Service Map and Chart Series, No. 15.
- Griffiss AFB, 1977, Spill Reports for Griffiss Air Force Base in 1977, Rome, New York.
- Griffiss AFB, 1989, Spill Reports for Griffiss Air Force Base in 1989, Rome, New York.
- Griffiss AFB, 1991, Spill Reports for Griffiss Air Force Base in 1991, Rome, New York.
- Halberg, H.N., Hunt, O.P., and F.H. Panszek, 1962, Water Resources of the Utica-Rome Area, New York, US Geological Survey Water-Supply Paper, 1499-C.

- Hvorslev, M. J., 1951, Time Lag and Soil Permeability in Groundwater Observations: United States Corps of Engineers Waterways Experiment Station Bulletin 36, Vicksburg, Mississippi, 50 p.
- Jerrard, Cathy, April 1995, Personal Communication, Griffiss AFB Contact, Griffiss AFB, Rome, New York.
- Konikow, L.F., and Bredehoeft, J.D., 1978, Computer Model of Two-Dimensional Solute Transport and Dispersion in Groundwater: United States Geological Survey, Techniques of Water Resources Investigations of the United States Geological Survey, Book 7, Chapter C2, 90p.
- Law Environmental Inc., 1993, Personal Communication with Griffiss AFB Fire Department Personnel, October, 1993, Kennesaw, Georgia.
- Law Environmental, Inc., 1994, Personal Communication With Griffiss AFB Environmental Management Flight Personnel, Kennesaw, Georgia, January.
- Law Environmental, Inc., 1995, Prefinal Report for an Engineering Evaluation/Cost Analysis Report for Building 771 (Pumphouse 5) at Griffiss AFB, Kennesaw, Georgia, January.
- Lee, M.D. 1988. "Bioremediation of Aquifers Contaminated with Organic Compounds." *CRC Critical Reviews in Environmental Control*, v. 18. p. 29-89.
- New York State Department of Environmental Conservation (NYSDEC), 1991, Water Quality Standards and Guidance Values, November.
- NYCRR, 1991, Water Quality Regulations for Surface Waters and Groundwater, 6NYCRR Parts 700-705, NYDEC, Division of Water.
- Parratt-Wolff, Inc., 1989, Install Monitoring Wells, Griffiss AFB, Rome, New York (Letter Report), Syracuse, New York, June.
- Parratt-Wolff, Inc., 1992, Groundwater Monitoring Well Installations at Pumphouse 5 (Building 771), Syracuse, New York, January.
- Reynolds, R.J., 1990, Availability of Groundwater from Unconsolidated Deposits in the Mohawk River Basin, New York, US Geological Survey Water-Resources Investigations Report No. 88-4091.
- Rifai, H.S., Bedient, P.B., Wilson, J.T., Miller, K.M., and Armstrong, J.M, 1988, "Biodegradation Modeling at Aviation Fuel Spill Site," *Journal of Environmental Engineering*, v. 114, no. 5, p. 1007-1029.
- TRC, 1991a, Tracer Tight™ Test of 23 Underground Storage Tanks and 1 Hydrant System at Griffiss AFB, Tucson, Arizona, October.
- TRC, 1991b, Shallow Soil Gas Investigation for Griffiss Air Force Base, Tucson, Arizona, November.
- UNC Geotech, 1990, Soil gas Investigation for Pumphouse 5 and Proposed Fuel Line Areas, Grand Junction, Colorado, March.

UNC Geotech, 1991, Draft Hydrogeology Study report for Griffiss AFB, Grand Junction, Colorado, January.

US EPA, 1994, Drinking Water Regulations and Health Advisories, Office of Water, December.

US Geological Survey, 1991, Geology of New York, Educational Leaflet No. 28, New York State Museum, New York.

Wiedemeier, Todd H., Downey, Douglas C., Wilson, John T., Kampbell, Donald H., Miller, Ross N., and Hansen, Jerry E., 1995, *Draft Technical Protocol for Implementing the Intrinsic Remediation (Natural Attenuation) with Long-term Monitoring Option for Dissolved-phase Fuel Contamination in Groundwater*. Prepared by the Air Force Center for Environmental Excellence.

**APPENDIX A**  
**CONTAINERS, PRESERVATIVES, PACKAGING, AND SHIPPING**  
**REQUIREMENTS FOR GROUNDWATER SAMPLES**

Appendix A - Soil, Soil Gas, and Ground Water Analytical Protocol

Matrix	Analysis	Method/Reference	Comments	Data Use	Recommended Frequency of Analysis	Sample Volume, Sample Container, Sample Preservation	Field or Fixed-Base Laboratory
Soil	Volatile organics	Gas chromatography/mass spectrometry method SW8240	Handbook method	Data is used to determine the extent of chlorinated solvent and aromatic hydrocarbon contamination, contaminant mass present, and the need for source removal	Each sampling round	Collect 100 g of soil in a glass container with Teflon®-lined cap; cool to 4°C	Fixed-base
Soil	Aromatic hydrocarbons (benzene, toluene, ethylbenzene, and xylene [BTEX]; trimethylbenzene isomers)	Purge and trap gas chromatography (GC) method SW8020	Handbook method modified for field extraction of soil using methanol	Data is used to determine the extent of soil contamination, the contaminant mass present, and the need for source removal	Each sampling round	Collect 100 g of soil in a glass container with Teflon-lined cap; cool to 4°C	Fixed-base
Soil	Total organic carbon (TOC)	SW9060 modified for soil samples	Procedure must be accurate over the range of 0.5-15 percent TOC	Relatively high amounts of TOC may be indicative of a reducing environment and may indicate the need for analysis of electron acceptors associated with that environment; the rate of migration of petroleum contaminants in groundwater is dependent upon the amount of TOC in the saturated zone soil; the rate of release of petroleum contaminants from the source into groundwater is dependent (in part) on the amount of TOC in the vadose zone soil	At initial sampling	Collect 100 g of soil in a glass container with Teflon-lined cap; cool to 4°C	Fixed-base

Appendix A (Continued)

Matrix	Analysis	Method/Reference	Comments	Data Use	Recommended Frequency of Analysis	Sample Volume, Sample Container, Sample Preservation	Field or Fixed-Base Laboratory
Soil	Total hydrocarbons, volatile and extractable	GC method SW8015 [modified]	Handbook method; reference is the California LUFT manual	Data are used to determine the extent of soil contamination, the contaminant mass present, and the need for source removal	Each sampling round	Collect 100 g of soil in a glass container with Teflon-lined cap, cool to 4°C	Fixed-base
Soil	Moisture	ASTM D-2216	Handbook method	Data are used to correct soil sample analytical results for moisture content (e.g., report results on a dry weight basis)	Each soil sampling round	Use a portion of soil sample collected for another analysis	Fixed-base
Soil	Grain size distribution	ASTM D422	Procedure provides a distribution of grain size by sieving	Data are used to infer hydraulic conductivity of aquifer, and are used in calculating sorption of contaminants	One time during life of project	Collect 250 g of soil in a glass or plastic container; preservation is unnecessary	Fixed-base
Soil gas	Oxygen content of soil gas	Electrochemical oxygen meter operating over the range of 0-25 percent of oxygen in the soil gas sample	The concentration of soil gas oxygen is often related to the amount of biological activity, such as the degradation of petroleum hydrocarbons; soil gas oxygen concentrations may decrease to the point where anaerobic pathways dominate	Data are used to understand the oxygen concentration gradient with depth and to determine the presence or absence of aerobic degradation processes	Each sampling round	N/A	Field

Appendix A (Continued)

Matrix	Analysis	Method/Reference	Comments	Data Use	Recommended Frequency of Analysis	Sample Volume, Sample Container, Sample Preservation	Field or Fixed-Base Laboratory
Soil gas	Carbon dioxide content of soil gas	Nondispersive infrared instrument operating over the range of approximately 0.1-15 percent	Soil gas carbon dioxide may be produced by the degradation of petroleum hydrocarbons	Data used to understand the carbon dioxide concentration gradient with depth and to infer the biological degradation of petroleum contaminants	Each sampling round	N/A	Field
Soil gas	Methane content of soil gas	Total combustible hydrocarbon meter using a platinum catalyst with a carbon trap, and operating in the low parts per million volume (ppmv) range	Methane is a product of the anaerobic degradation of petroleum hydrocarbons	Soil gas methane can be used to locate contaminated soil and to determine the presence of anaerobic processes; see discussion of data use for methane in water	Each sampling round	N/A	Field
Soil gas	Fuel hydrocarbon vapor content of soil gas	Total combustible hydrocarbon meter operating over a wide ppmv range	Soil gas hydrocarbons indicate the presence of these contaminants in the soil column	Data used to understand the petroleum hydrocarbon concentration gradient with depth and to locate the most heavily contaminated soils	Each sampling round	N/A	Field
Water	Ferrous (Fe <sup>2+</sup> )	Colorimetric A3500-Fe D	Field only	May indicate an anaerobic degradation process due to depletion of oxygen, nitrate, and manganese	Each sampling round	Collect 100 mL of water in a glass container; acidify with hydrochloric acid per method	Field
Water	Ferrous (Fe <sup>2+</sup> )	Colorimetric HACH 25140-25	Alternate method; field only	May indicate an anaerobic degradation process due to depletion of oxygen, nitrate, and manganese	Each sampling round	Collect 100 mL of water in a glass container	Field
Water	Temperature	E170.1	Field only	Well development	Each sampling round	N/A	Field

Appendix A (Continued)

Matrix	Analysis	Method/Reference	Comments	Data Use	Recommended Frequency of Analysis	Sample Volume, Sample Container, Sample Preservation	Field or Fixed-Base Laboratory
Water	Chloride	Mercuric nitrate titration A4500-Cl <sup>-</sup> C	Ion chromatography (IC) method E300 or method SW9050 may also be used	General water quality parameter used as a marker to verify that site samples are obtained from the same groundwater system	Each sampling round	Collect 250 mL of water in a glass container	Field
Water	Oxygen	Dissolved oxygen meter	Refer to method A4500 for a comparable laboratory procedure	The oxygen concentration is a data input to the Bioplume model, concentrations less than 1 mg/L generally indicate an anaerobic pathway	Each sampling round	Collect 300 mL of water in biochemical oxygen demand bottles; analyze immediately, alternately, measure dissolved oxygen <i>in situ</i>	Field
Water	pH	E150.1/SW9040, direct reading meter	Protocols/Handbook methods	Aerobic and anaerobic processes are pH-sensitive	Each sampling round	Collect 100-250 mL of water in a glass or plastic container; analyze immediately	Field
Water	Conductivity	E120.1/SW9050, direct reading meter	Protocols/Handbook methods	General water quality parameter used as a marker to verify that site samples are obtained from the same groundwater system	Each sampling round	Collect 100-250 mL of water in a glass or plastic container	Field
Water	Alkalinity	A2320, titrimetric, E310.2, colorimetric	Handbook method	General water quality parameter used (1) as a marker to verify that all site samples are obtained from the same groundwater system and (2) to measure the buffering capacity of groundwater	Each sampling round	Collect 250 mL of water in a glass or plastic container; analyze within 6 hours	Field

Appendix A (Continued)

Matrix	Analysis	Method/Reference	Comments	Data Use	Recommended Frequency of Analysis	Sample Volume, Sample Container, Sample Preservation	Field or Fixed-Base Laboratory
Water	Nitrate ( $\text{NO}_3^-$ )	IC method E300 or method SW9056; colorimetric, method E353.2	Method E300 is a Handbook method; method SW9056 is an equivalent procedure	Substrate for microbial respiration if oxygen is depleted	Each sampling round	Collect up to 40 mL of water in a glass or plastic container, cool to 4°C; analyze within 48 hours	Fixed-base
Water	Sulfate ( $\text{SO}_4^{2-}$ )	IC method E300 or method SW9056	Method E300 is a Handbook method; method SW9056 is an equivalent procedure	Substrate for anaerobic microbial respiration	Each sampling round	Collect up to 40 mL of water in a glass or plastic container, cool to 4°C	Fixed-base
Water	Sulfate ( $\text{SO}_4^{2-}$ )	HACH Sulfa Ver 4 method	Photometric	Substrate for anaerobic microbial respiration	Each sampling round	Collect up to 40 mL of water in a glass or plastic container, cool to 4°C	Field
Water	Redox potential	A2580 B	Measurements are made with electrodes; results are displayed on a meter; samples should be protected from exposure to atmospheric oxygen	The redox potential of groundwater influences and is influenced by the nature of the biologically mediated degradation of contaminants; the redox potential of groundwater may range from more than 200 mV to less than -400 mV	Each sampling round	Collect 100–250 mL of water in a glass container, filling container from bottom; analyze immediately	Field
Water	Dissolved sulfide ( $\text{S}^{2-}$ )	Hach Model HS-C test kit	Procedure uses reagent-impregnated test strips to determine sulfide species (except insoluble metal sulfides) in the 0 to 5 mg/L range	Product of sulfate-based anaerobic microbial respiration; analyze in conjunction with sulfate analysis	Each sampling round	Collect 100 mL of water in a glass container; analyze immediately	Field

Appendix A (Continued)

Matrix	Analysis	Method/Reference	Comments	Data Use	Recommended Frequency of Analysis	Sample Volume, Sample Container, Sample Preservation	Field or Fixed-Base Laboratory
Water	Methane, carbon dioxide	RSKSOP-114 modified to analyze water samples for methane and carbon dioxide by headspace sampling with dual thermal conductivity and flame ionization detection (also, see reference in note 10)	Method published and used by the U.S. Environmental Protection Agency (EPA) Robert S. Kerr Laboratory	The presence of methane suggests BTEX degradation via an anaerobic pathway utilizing carbon dioxide (carbonate) as the electron acceptor (methanogenesis); a redox potential measurement of less than -200 mV could be indicative of methanogenesis and should be followed by the analysis referenced here; the presence of free carbon dioxide dissolved in groundwater is unlikely because of the carbonate buffering system of water, but if detected, the carbon dioxide concentrations should be compared with background to determine whether they are elevated; elevated concentrations of carbon dioxide could indicate an aerobic mechanism for bacterial degradation of petroleum	Each sampling round	Collect water samples in 40 mL volatile organic analysis (VOA) vials with butyl gray/Teflon-lined caps; cool to 4°C	Fixed-base Laboratory

Appendix A (Continued)

Matrix	Analysis	Method/Reference	Comments	Data Use	Recommended Frequency of Analysis	Sample Volume, Sample Container, Sample Preservation	Field or Fixed-Base Laboratory
	Ethane, ethene	RSKSOP-114 (cont'd)	Ethane and ethene are analyzed in addition to the other analytes only if chlorinated hydrocarbons are suspected of undergoing biological transformation	Ethane and ethene are products of the biotransformation of chlorinated hydrocarbons under anaerobic conditions. The presence of these chemicals may indicate that anaerobic degradation is occurring			
Water	Carbon dioxide	HACH	Titrimetric; alternate method	The presence of free carbon dioxide dissolved in groundwater is unlikely because of the carbonate buffering system of water, but if detected, the carbon dioxide concentrations should be compared with background to determine whether they are elevated; elevated concentrations of carbon dioxide could indicate an aerobic mechanism for bacterial degradation of petroleum	Each sampling round	N/A	Field

Appendix A (Continued)

Matrix	Analysis	Method/Reference	Comments	Data Use	Recommended Frequency of Analysis	Sample Volume, Sample Container, Sample Preservation	Field or Fixed-Base Laboratory
Water	Aromatic hydrocarbons (BTEX, trimethylbenzene isomers)	Purge and trap GC method SW8020	Handbook method; analysis may be extended to higher molecular weight alkyl benzenes	Method of analysis for BTEX, which is the primary target analyte for monitoring natural attenuation; BTEX concentrations must also be measured for regulatory compliance; method can be extended to higher molecular weight alkyl benzenes, trimethylbenzenes are used to monitor plume dilution if degradation is primarily anaerobic	Each sampling round	Collect water samples in a 40 mL VOA vial, cool to 4°C; add hydrochloric acid to pH 2	Fixed-base
Water	Total hydrocarbons, volatile and extractable	GC method SW8015 [modified]	Handbook method; reference is the California LUFT manual	Data used to monitor the reduction in concentrations of total fuel hydrocarbons (in addition to BTEX) due to natural attenuation; data also used to infer presence of an emulsion or surface layer of petroleum in water sample, as a result of sampling	One time per year or as required by regulations	Volatile hydrocarbons—collect water samples in a 40 mL VOA vial; cool to 4°C; add hydrochloric acid to pH 2 Extractable hydrocarbons—collect 1 L of water in a glass container, cool to 4°C; add hydrochloric acid to pH 2	Fixed-base
Water	Polycyclic aromatic hydrocarbons (PAHs) (optional)	GC/mass spectroscopy method SW8270; high-performance liquid chromatography method SW8310	Analysis needed only for several samples per site	PAHs are components of fuel and are typically analyzed for regulatory compliance; data on their concentrations are not used currently in the evaluation of natural attenuation	At initial sampling and at site closure or as required by regulations	Collect 1 L of water in a glass container, cool to 4°C	Fixed-base

Appendix A (Continued)

Matrix	Analysis	Method/Reference	Comments	Data Use	Recommended Frequency of Analysis	Sample Volume, Sample Container, Sample Preservation	Field or Fixed-Base Laboratory
Water	Total fuel carbon (optional)	Purge and trap GC method SW8020 modified to measure all volatile aromatic hydrocarbons present in the sample	A substitute method for measuring total volatile hydrocarbons, reports amount of fuel as carbon present in the sample; method available from the U.S. EPA Robert S. Kerr Laboratory	Data used to monitor the reduction in concentrations of total fuel hydrocarbons (in addition to BTEX) due to natural attenuation	At initial sampling and at site closure	Collect 40 mL of water in glass vials with Teflon-lined caps; add sulfuric acid to pH 2; cool to 4°C	Fixed-base
Water	Volatile Organics	GS/MS method SW8240	Handbook method	Method of analysis for chlorinated solvents and aromatic hydrocarbons for evaluation of cometabolic degradation; measured for regulatory compliance when chlorinated solvents are known site contaminants	Each sampling round	Collect water samples in a 40 mL VOA vial; cool to 4°C; add hydrochloric acid to pH 2	Fixed-base
Water	Dissolved organic carbon (DOC) (optional)	A5310 C	An oxidation procedure whereby carbon dioxide formed from DOC is measured by an infrared spectrometer. The minimum detectable amount of DOC is 0.05 mg/L	An indirect index of microbial activity	Each sampling round	Collect 100 mL of water in an amber glass container with Teflon-lined cap; preserve with sulfuric acid to pH less than 2; cool to 4°C	Fixed-base

Appendix A (Concluded)

NOTES:

1. "HACH" refers to the HACH Company catalog, 1990.
2. "A" refers to *Standard Methods for the Examination of Water and Wastewater*, 18th edition, 1992.
3. "E" refers to *Methods for Chemical Analysis of Water and Wastes*, U.S. Environmental Protection Agency, March 1979.
4. "Protocols" refers to the AFCEE *Environmental Chemistry Function Installation Restoration Program Analytical Protocols*, 11 June 1992.
5. "Handbook" refers to the AFCEE *Environmental Chemistry Function Installation Restoration Program (IRP) Remedial Investigations and Feasibility Studies (RI/FS)*, September 1993.
6. "SW" refers to the *Test Methods for Evaluating Solid Waste, Physical, and Chemical Methods*, SW-846, U.S. Environmental Protection Agency, 3rd edition, 1986.
7. "ASTM" refers to the *American Society for Testing and Materials*, current edition.
8. "RSKSOP" refers to *Robert S. Kerr (Environmental Protection Agency Laboratory) Standard Operating Procedure*.
9. "LUFT" refers to the state of California *Leaking Underground Fuel Tank Field Manual*, 1988 edition.
10. *International Journal of Environmental Analytical Chemistry*, Volume 36, pp. 249-257, "Dissolved Oxygen and Methane in Water by a Gas Chromatography Headspace Equilibration Technique," by D. H. Kambell, J. T. Wilson, and S. A. Vandegriff.

**APPENDIX B**

**AVAILABLE SOIL AND GROUNDWATER ANALYTICAL RESULTS AND  
SOIL BORING LOGS**

TABLE 2-1

SUMMARY OF FREE PRODUCT THICKNESS  
 BUILDING 771 - PUMPHOUSE 5  
 Griffiss Air Force Base  
 Rome, New York

	Jun-89	Nov-91	Dec-91	Apr-92	May-92	Jun-92	Aug-92	Sep-92	Oct-92	Nov-92	Dec-92	Jan-93
771MW-1	FP	2.04		0.23	0.25	0.18	0.25	0.11	0.29	0.32	0.39	0.85
771MW-2	ND			0		0	0	0	0	0	0	0
771MW-3	FP	4.85		4.10	4.10	4.53	4.69	2.02	0.82	0.03	4.35	4.14
771MW-4	NI		0.01		0.00							
771MW-5	NI		0									
771MW-6	NI		0									
771MW-7	NI		5.80		3.06							
771MW-8	NI		0									
771MW-9	NI		0									

NOTES:

- Values represent thickness of free product, in feet.
- Blanks indicate free product was not measured in well.
- FP = free product detected
- ND = free product not detected
- NI = well not installed

TABLE 2-1

SUMMARY OF FREE PRODUCT THICKNESS  
 BUILDING 771 - PUMPHOUSE 5  
 Griffiss Air Force Base  
 Rome, New York

	Feb-93	Mar-93	Apr-93	May-93	Jun-93	Jul-93	Aug-93	Oct-93	Jan-95
771MW-1	0	0.01	1.32-2.48	0.53-0.30	0.37-0.03	0.05-0.02	0.03	0.06	0.30
771MW-2	0	0	0	0	0	0	0	0	0
771MW-3	4.31-2.60	0	5.07-4.10	4.77-0.10	0.43-0.01	0.09-0.02	0.13	4.36	0.03
771MW-4		0	0	0	0	0	0	0	0
771MW-5		0	0	0	0	0	0	0	0
771MW-6		0	0	0	0	0	0	0	0
771MW-7		5.4	1.45-0.1	0.04-0.94	0.80-0.01	0.23-0.16	0.24	0.02	2.94
771MW-8		0	0.04-0.46	0.59-0.40	0.27-0.02	0-0.06	0.05	0	0.23
771MW-9		0	0	0	0	0	0	0	0

NOTES:

Values represent thickness of free product, in feet.  
 Blanks indicate free product was not measured in well.

PREPARED/DATE: MRA 1/95  
 CHECKED/DATE: MEB 1/95

FIGURE 2-10

**COMPARISON OF FRESH JP-4 FUEL AND  
SAMPLE COLLECTED FROM MW-7 PRODUCT**  
GRIFFISS AIR FORCE BASE  
ROME, NEW YORK

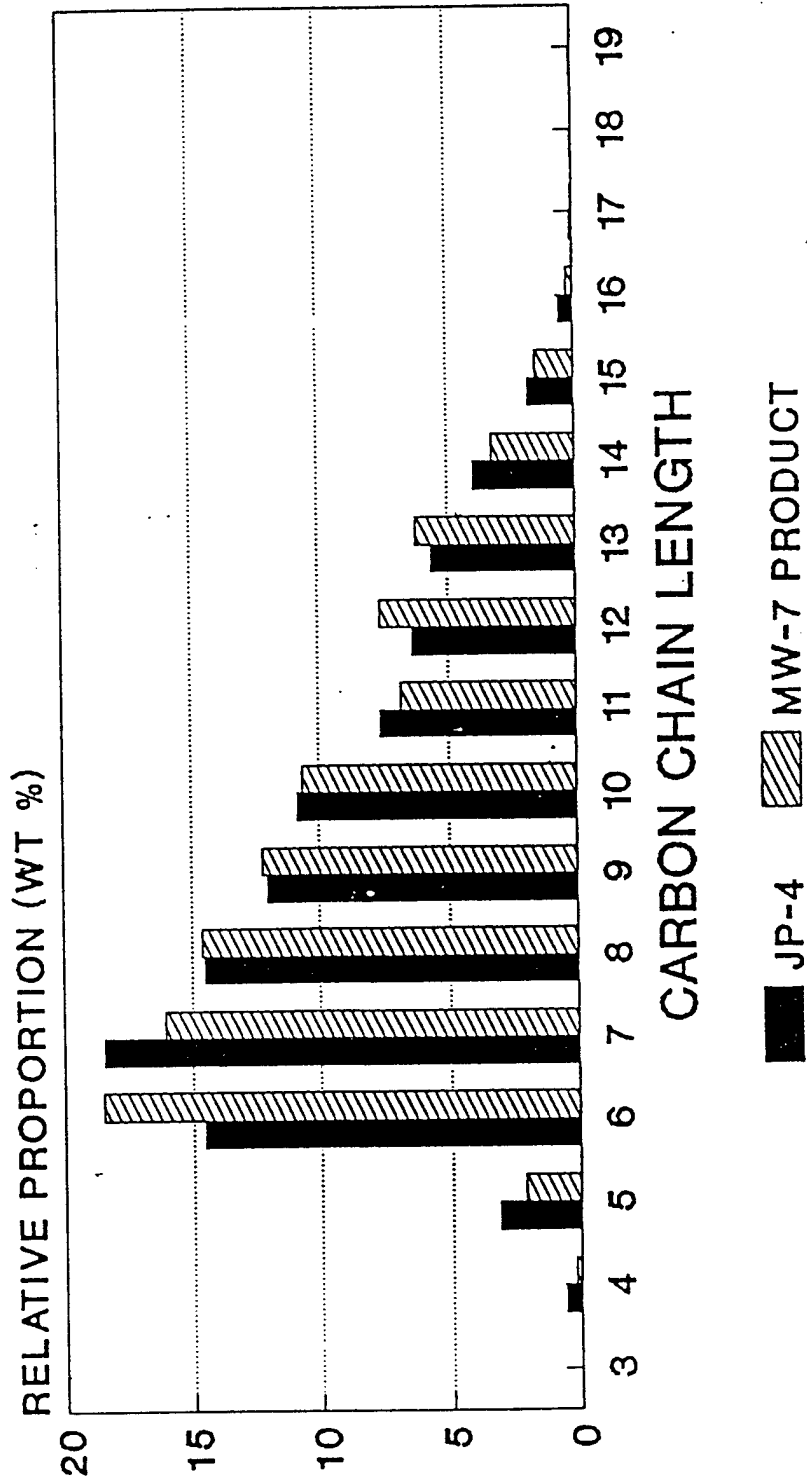

TABLE 2-6

COMPARISON OF PURE JP-4 AND MW-7 PRODUCT  
Griffiss Air Force Base  
Rome, New York

Carbon Chain Length	Weight Percent		Percent Increase (Decrease)
	JP-4	771MW-7	
3	0.01	0	(100.00%)
4	0.57	0.22	(61.40%)
5	3.1	2.13	(31.29%)
6	14.54	18.45	26.89%
7	18.39	16.04	(12.78%)
8	14.52	14.62	0.69%
9	12.02	12.25	1.91%
10	10.87	10.65	(2.02%)
11	7.57	6.83	(9.78%)
12	6.35	7.62	20.00%
13	5.63	6.19	9.95%
14	3.96	3.22	(18.69%)
15	1.8	1.46	(18.69%)
16	0.52	0.27	(48.08%)
17	0.08	0.03	(62.50%)
18	0.03	0.01	(66.67%)
19	0.04	0.01	(75.00%)

PREPARED/DATE: AAA 1-24-95  
CHECKED/DATE: MEB 1/24/95

TABLE 2-5

CONCENTRATIONS OF ANALYTES DETECTED  
IN PUMPHOUSE NO. 5 WELLS  
JANUARY 1992  
Griffiss Air Force Base  
Rome, New York

PARAMETER	771MW-4	771MW-5	771MW-6	771MW-8	771MW-801	771MW-9
<u>Benzene, Toluene, Ethylbenzene &amp; Xylenes, Method 8020</u>						
Benzene	5200* µg/L	<0.5 µg/L	<0.5 µg/L	750* µg/L	11000* µg/L	<0.5 µg/L
Ethylbenzene	610* µg/L	<0.5 µg/L	<0.5 µg/L	1100* µg/L	1200* µg/L	<0.5 µg/L
Toluene	610* # µg/L	<0.5 µg/L	<0.5 µg/L	250* µg/L	2400* µg/L	<0.5 µg/L
Xylenes	7500* µg/L	<1.0 µg/L	<1.0 µg/L	6600* µg/L	16000* µg/L	<1.0 µg/L
	2.970			8.700	30.600	
<u>Lead Totals By GFAA, Method 239.2</u>	.0376 mg/L	0.0057 mg/L	0.0418 mg/L	.0536 mg/L	0.0584 mg/L	0.0247 mg/L
Lead by GFAA						
<u>Lead, Dissolved, By GFAA, Method 239.2</u>	.0023 mg/L	<0.002 mg/L	<0.002 mg/L	<.002 mg/L	<.002 mg/L	<.002 mg/L
Lead, Dissolved, By GFAA						
<u># Total Petroleum Hydrocarbons - CAL DHS</u>						
Diesel	<500 µg/L	<500 µg/L	<500 µg/L	13400 µg/L	<500 µg/L	<500 µg/L
Gasoline	28.5 ppm	0.2 ppm	0.2 ppm	99.5 ppm	65.5 ppm	0.6 ppm
Ethylene Glycol	<0.05 mg/L	<0.04 mg/L	<0.04 mg/L	<0.04 mg/L	<0.04 mg/L	<0.04 mg/L

# - Concentration over the upper range limit (URL).

\* - Results from the diluted sample.

J - Concentration estimated

B - Also found in associated method blank.

PREPARED/DATE: AFA 1/95  
CHECKED/DATE: MEB 1/95

TABLE 2-7

POSITIVE RESULTS FOR QUARTER I  
 NOVEMBER 1992  
 Griffiss Air Force Base  
 Rome, New York

PARAMETER	TEST	UNITS	771MW-2	771MW-201	771MW-4	771MW-5	771MW-6	771MW-8	771MW-9
<b>METALS</b>									
Aluminum	SW6010	mg/L	<0.21	<0.21	5.30	<0.21	0.64	0.995	<0.21
Barium	SW6010	mg/L	0.126	0.12	0.08	0.043	0.064	0.085	0.087
Calcium	SW6010	mg/L	120	125	102	67.0	135	113	128
Iron	SW6010	mg/L	39.2	39.2	20.6	7.0	1.88	55.5	32.6
Magnesium	SW6010	mg/L	19.4	18.7	16.8	7.3	14.7	11.8	15.7
Manganese	SW6010	mg/L	5.1	5.1	2.84	0.62	0.19	4.55	4.61
Potassium	SW6010	mg/L	3.66	3.68	2.54	4.13	4.49	1.74	1.32
Sodium	SW6010	mg/L	10.9	9.8	2.44	1.2	13.6	1.28	1.64
Zinc	SW6010	mg/L	<0.01	0.19	0.046	<0.01	<0.01	0.01	<0.01
Arsenic	SW7060	mg/L	0.022	0.021	0.020	<0.01	<0.01	0.033	0.013
<b>VOLATILE ORGANICS</b>									
2-Hexanone	SW8240	µg/L	<5	<5	<5	<5	<5	130	<5
Acetone	SW8240	µg/L	12 J	<5	1900	6.2	<5	4300	46
Benzene	SW8240	µg/L	<5	<5	3100	<5	2.1 J	7800	<5
Ethylbenzene	SW8240	µg/L	<5	<5	450	<5	1.3 T	1200	<5
Methylene Chloride	SW8240	µg/L	6.2 B	9.5 B	7.6 B	6.9 B	7.3 B	7.8 B	7.0 B
Toluene	SW8240	µg/L	<5	<5	19	<5	<5	1300	<5
Xylenes, Total	SW8240	µg/L	<5	<5	1200	<5	<5	3600	<5

TABLE 2-7

POSITIVE RESULTS FOR QUARTER I  
 NOVEMBER 1992  
 Griffiss Air Force Base  
 Rome, New York

PARAMETER	TEST	UNITS	771MW-2	771MW-201	771MW-4	771MW-5	771MW-6	771MW-8	771MW-9
<b>SEMI-VOLATILES</b>									
2-Methylnaphthalene	SW8270	µg/L	<10	<10	30.2	<10	<10	60.4	<10
Dibenzofuran	SW8270	µg/L	<10	<10	<10	<10	<10	1.0 J	<10
Diethyl Phthalate	SW8270	µg/L	<10	<10	<10	<10	<10	1.0 J	1.7 J
Naphthalene	SW8270	µg/L	<10	<10	61.3	<10	<10	118.3	<10
Phenol	SW8270	µg/L	<10	<10	4.1 R	<10	<10	<10	<10
bis(2-ethylhexyl) phthalate	SW8270	µg/L	<10	<10	<10	<10	<10	<10	1.1 J
<b>GLYCOLS</b>									
Total Glycol	NYS DOH APC-44	mg/L	0.07 T	<0.05	0.08	<0.05	<0.05	<0.05	0.12

Duplicate Pairs:  
 771MW-2 - 771MW-201

B - False positive based upon blank data.  
 F - False positive based upon field blank data.  
 J - Estimated quantitation based upon QC data.  
 R - Data rejected due to QC data. DO NOT USE.  
 T - False positive based upon trip blank data.

ARA 1-24-95  
 PREPARED/DATE: MEB 1/24/95  
 CHECKED/DATE:  
 2 of 2

TABLE 2-8

POSITIVE RESULTS FOR QUARTER II  
MARCH 1993  
Griffiss Air Force Base  
Rome, New York

PARAMETER	TEST CODE	UNITS	771MW-2	771MW-201	771MW-4	771MW-5	771MW-6	771MW-8	771MW-9
<b>METALS</b>									
Aluminum	SW6010	mg/L	<0.21	<0.21	<0.21	<0.21	<0.21	2.69	<0.21
Barium	SW6010	mg/L	0.122	0.104	0.135	0.046	0.058	0.088	0.12
Calcium	SW6010	mg/L	132	128	99.1	81.5	143	128	125
Iron	SW6010	mg/L	24.3	27.1	12.8	8.51	0.34	63.8	103
Magnesium	SW6010	mg/L	17.5	16.3	13.4	8.16	14.1	11.6	12.6
Manganese	SW6010	mg/L	4.79	4.71	3.00	0.722	0.438	4.99	5.42
Potassium	SW6010	mg/L	2.80	2.85	1.22	2.72	3.48	1.70 J	0.95 J
Sodium	SW6010	mg/L	10.8	11.3	7.02	4.54	9.93	1.59	1.95
Zinc	SW6010	mg/L	0.231 J	0.158	0.215	0.284	0.162	0.131	0.098
Arsenic	SW7060	mg/L	0.015	0.016	<0.01	<0.01	<0.01	0.019	0.047
<b>VOLATILE ORGANICS</b>									
Acetone	SW8240	µg/L	3.9 JB	2.9 JB	<50	11 JB	9.1 JB	<250	<5
Benzene	SW8240	µg/L	<5	7.6	4200 Jd	<5	1.1 JB	8800	<5
Chloromethane	SW8240	µg/L	4.8 JB	8.1 JB	<100	<10	4.2 JB	160 J	<10
Ethylbenzene	SW8240	µg/L	<5	1.1 J	410	<5	<5	1400	<5
Methylene Ethyl Ketone	SW8240	µg/L	<5	<5	<50	3.4 J	<5	<250	<5
Methylene Chloride	SW8240	µg/L	6.2 JB	5.1 JB	30 JB	3 JB	4.6 JB	210 JB	5.1 JB
Toluene	SW8240	µg/L	<5	1.3 J	44 J	<5	<5	1400	<5
Xylenes, Total	SW8240	µg/L	<5	2.2 J	1200	<5	<5	4300	<5

TABLE 2-8

POSITIVE RESULTS FOR QUARTER II

MARCH 1993

Griffiss Air Force Base  
Rome, New York

PARAMETER	TEST CODE	UNITS	771MW-2	771MW-201	771MW-4	771MW-5	771MW-6	771MW-8	771MW-9
<b>SEMI-VOLATILE ORGANICS</b>									
2-Methylnaphthalene	SW8270	µg/L	<10	<10	33	<10	<10	2 J	<10
Acenaphthene	SW8270	µg/L	<10	<10	<10	<10	<10	1 J	<10
Fluorene	SW8270	µg/L	<10	<10	<10	<10	<10	1 J	<10
Naphthalene	SW8270	µg/L	<10	<10	87	<10	<10	4 J	<10
<b>GLYCOLS</b>									
Total Glycol	NYS DOH APC-44	µg/L	0.09 J	0.07 J	<0.04	<0.04	0.09 J	0.09 J	0.14 J

J - Estimated quantitation based upon QC data.  
 JB - Estimated quantitation: possibly biased high or false positive based on QC data.  
 Jd - Estimated result due to dilution.  
 JH - Estimated quantitation: possibly biased high based on QC data.  
 JL - Estimated quantitation: possibly biased low based on QC data.  
 NT - Not tested; samples received by laboratory outside of holding time.

Duplicate Pairs:  
 771MW-2 - 771MW-201

PREPARED/DATE: ARA/2495  
 CHECKED/DATE: MEB 1/21/95

TABLE 2-9

## POSITIVE RESULTS FOR QUARTER III

JUNE 1993

Griffiss Air Force Base  
Rome, New York

PARAMETER	TEST CODE	UNITS	771MW-2	771MW-201	771MW-4	771MW-5	771MW-6	771MW-8	771MW-9
<b>METALS</b>									
Barium	SW6010	mg/L	0.132	0.132	0.063	0.021	< .02	0.064	0.056
Calcium	SW6010	mg/L	147	138	93.7	55.3	90.0	119	145
Iron	SW6010	mg/L	56.3	55.9	14.8	3.19	0.250	39.3	40.7
Magnesium	SW6010	mg/L	18.4	17.8	13.7	5.26	15.2	11.2	14.3
Manganese	SW6010	mg/L	7.01	6.84	3.65	0.350	0.138	4.04	5.08
Potassium	SW6010	mg/L	2.20	2.11	1.39	4.37	3.06	1.24	1.19
Sodium	SW6010	mg/L	5.92	5.86	2.77	1.42	22.0	1.53	1.45
Zinc	SW6010	mg/L	0.172	0.197	0.188	0.228	0.213	0.234	0.160
Arsenic	SW7060	mg/L	0.018	0.016	0.012	< 0.01	< 0.01	0.022	0.029
Lead	SW7421	mg/L	0.006	0.007	0.017	< .005	< 0.005	< .0005	< .005
<b>VOLATILE ORGANICS</b>									
Acetone	SW8240	µg/L	860 JD	960 JD	2200 JD	21.0 JB	14.0 JB	2400 JD	18.0
Benzene	SW8240	µg/L	< 5.0	< 5.0	5900 JD	< 5.0	< 5.0	9100 JD	< 5.0
Ethylbenzene	SW8240	µg/L	< 5.0	< 5.0	700 JD	< 5.0	< 5.0	1600 JD	< 5.0
Methyl Ethyl Ketone (2-Butanone)	SW8240	µg/L	29.0	11.0	2200 JD	< 5.0	< 5.0	< 5.0	< 5.0
Methylene Chloride	SW8240	µg/L	49.0	16.0	6.5 JB	8.7 JB	7.0 JB	7.0 JB	< 5.0
Toluene	SW8240	µg/L	< 5.0	< 5.0	29.0	< 5.0	< 5.0	1700 JD	< 5.0
Xylenes, Total	SW8240	µg/L	< 5.0	< 5.0	1900 JD	< 5.0	< 5.0	3600 JD	< 5.0

TABLE 2-9

POSITIVE RESULTS FOR QUARTER III  
 JUNE 1993  
 Griffiss Air Force Base  
 Rome, New York

PARAMETER	TEST CODE	UNITS	771MW-2	771MW-201	771MW-4	771MW-5	771MW-6	771MW-8	771MW-9
<b>SEMI-VOLATILES</b>									
2-Methylnaphthalene	SW8270	µg/L	<10	<10	44	<10	<10	13.0	<10
Naphthalene	SW8270	µg/L	<10	<10	110	<10	<10	64.6	<10
bis(2-ethylhexyl) phthalate	SW8270	µg/L	<10	<10	2.2 J	1.8 J	<10	1.0 J	<10
<b>GLYCOLS</b>									
Total Glycols			0.07 J	0.46	0.11	<0.05	0.93	0.14	0.16

J - Estimated quantitation based upon QC data.  
 JB - Estimated quantitation: possible biased high or false positive based on QC data.  
 JD - Estimated result due to dilution.  
 R - Datum rejected based upon QC data: DO NOT USE.

Duplicate Pairs:  
 771MW-2 - 771MW-201

PREPARED/DATE: ARA 1-24-95  
 CHECKED/DATE: MEB 1/24/95

TABLE 2-10

POSITIVE RESULTS FOR QUARTER IV  
 SEPTEMBER 1993  
 Griffiss Air Force Base  
 Rome, New York

PARAMETER	TEST CODE	UNITS	771MW-2	771MW-201	771MW-4	771MW-5	771MW-6	771MW-8	771MW-801	771MW-9
<b>METALS</b>										
Aluminum	SW6010	mg/L	<0.1	0.16	<0.1 JL	<0.1	<0.1 JL	<0.1	36.0	<0.1
Barium	SW6010	mg/L	0.11	0.1	0.09	0.05	0.067	0.082	0.084	0.079
Cadmium	SW6010	mg/L	<0.004	<0.004	<0.004	0.005	<0.004	<0.004	<0.004	0.006
Calcium	SW6010	mg/L	120	120	0.094	69.0	160	110	110	130
Copper	SW6010	mg/L	<0.008	0.009	<0.008	<0.008	0.019	<0.008	0.052	<0.008
Iron	SW6010	mg/L	37.0	36.0	17.0 JH	6.0	0.16 JH	56.0	56.0	34.0
Magnesium	SW6010	mg/L	16.0	15.0	16.0	6.5	18.0	12.0	12.0	15.0
Manganese	SW6010	mg/L	5.2	5.2	4.3	0.6	0.64	4.4	4.5	5.1
Nickel	SW6010	mg/L	0.027	<0.025	<0.025	<0.025	<0.025	<0.025	0.036	<0.025
Potassium	SW6010	mg/L	1.8	1.7	1.7	4.0	3.5	1.2	1.2	1.1
Sodium	SW6010	mg/L	2.6	2.3	3.4	1.2	13.0	1.3	1.2	2.0
Zinc	SW6010	mg/L	<0.007	<0.007	<0.007	0.014	0.012	<0.007	0.56	0.016
Arsenic	SW7060	mg/L	0.025	0.025	0.018	0.01	<0.002	0.033	0.034	0.023
Lead	SW7461	mg/L	<0.001	<0.001	<0.001	<0.001	<0.001	<0.001	0.0037	<0.001
<b>VOLATILE ORGANICS</b>										
Acetone	SW8240	µg/L	1400	870	<50	<50	<50	<25	<25	<500
Benzene	SW8240	µg/L	<1.0	<1.0	3200	<1.0	<1.0	6000	6000	<1.0
Ethylbenzene	SW8240	µg/L	<1.0	<1.0	47	<1.0	<1.0	1000	1000	<1.0

TABLE 2-10

POSITIVE RESULTS FOR QUARTER IV  
 SEPTEMBER 1993  
 Griffiss Air Force Base  
 Rome, New York

PARAMETER	TEST CODE	UNITS	771MW-2	771MW-201	771MW-4	771MW-5	771MW-6	771MW-8	771MW-801	771MW-9
Methylene Chloride	SW8240	µg/L	<10		17 JT	13 JT	12 JT	<10	<10	<10
Toluene	SW8240	µg/L	<1.5	<1.5	<1.5	<1.5	<1.5	380	380	<1.5
Xylenes, Total	SW8240	µg/L	<4.0	<4.0	180	<4.0	<4.0	3800	3800	<4.0
<b>SEMI-VOLATILES</b>										
2-Methylnaphthalene	SW8270	µg/L	<4.0	<4.4	46	<4.1	<4.1	9.4	18	<4.0
Naphthalene	SW8270	µg/L	<3.0	<3.3	130	<3.1	<3.1	60	89	<3.0
Phenol	SW8270	µg/L	<4.0	<4.4	67.0	<4.1	<4.1	130	35	<4.0

JH - Estimated quantitation: possibly biased high based on QC data.  
 JL - Estimated quantitation: possibly biased low based on QC data.  
 JT - Estimated quantitation: possibly biased high or false positive based upon trip blank data.  
 NT - Not tested; samples received by laboratory outside of holding time.  
 R - Datum rejected based upon AC data: DO NOT USE.

Duplicate Pairs:  
 771MW-2 - 771MW-201  
 771MW-8 - 771MW-801

PREPARED/DATE: ARA 1-24-95  
 CHECKED/DATE: MEB 1/21/95

west central portion of the base. A significant portion of the zone consists of on-base housing. Zone 3 includes all or significant portions of the following areas:

- Central Base and Pumphouse 5
- Threemile Creek
- Bulk Fuel Storage Area

Interpretation of water level data collected from monitoring wells in Zone 3 suggests a ground-water flow regime ranging from southwesterly to southerly. Interpretation of hydrogeology in this zone is hampered by the relative sparsity of well data within the zone. This zone is interpreted as primarily representing an area of ground-water discharge.

## 5.2 REGULATORY STANDARDS AND GUIDELINES

During this investigation, volatile and semi-volatile organic compounds, metals, total cyanide, and total glycols were detected in ground-water samples collected from the monitoring wells. This section presents the Applicable or Relevant and Appropriate Requirements (ARARs) for the constituents detected in the ground water. These ARARs will be compared to the levels of constituents detected in each area in Section 5.3.

### 5.2.1 Federal Standards and Guidelines

The EPA has established maximum contaminant levels (MCLs) for a number of chemicals in accordance with the Safe Drinking Water Act (SDWA). An MCL is the chemical-specific maximum permissible level of a contaminant which may be delivered to any user of a public water system. The MCL is derived by considering such factors as health effects data, analytical detection limits, treatment technology, and economic impact. The MCL is applicable to public water systems at the point of delivery. Ground water in the vicinity of Griffiss AFB is not currently used as a source of potable water because municipal water service was extended to residents in the area in proximity of the base in 1992. However, MCLs are relevant and appropriate criteria for constituents detected in these ground-water samples because the ground water in the vicinity of Griffiss AFB has been used in the past as a source of potable water and may again be used for this purpose. The federal MCLs for the chemical constituents detected are provided in Table 5-1.

TABLE 5-1

STATE AND FEDERAL ARARs FOR GROUND WATER  
Griffiss AFB, Rome, New York

Compounds	Federal <sup>a</sup> MCL (mg/L)	State Ground <sup>b</sup> Water Standard (mg/L)	State <sup>c</sup> MCL (mg/L)
<b>Volatile Organic Compounds</b>			
1,1-Dichloroethane	—	0.005	—
1,1-Dichloroethylene	0.007	0.005	—
1,1,1-Trichloroethane	0.2	0.005	—
1,1,2-Trichloroethane	0.005	0.005	—
1,2-Dichloroethane	0.005	0.005	—
1,2,4-Trichlorobenzene	0.07	0.005	—
1,4-Dichlorobenzene (p-)	0.075	0.0047	—
Benzene	0.005	0.0007	—
Bromodichloromethane	0.1	0.05	—
Carbon tetrachloride	0.005	0.005	—
Chlorobenzene	—	0.005	—
Chloroform	0.1	0.007	—
cis-1,2-Dichloroethylene	0.07	—	—
Ethylbenzene	0.7	0.005	—
Methylene chloride	0.005	0.005	0.10 (t)
Tetrachloroethylene	0.005	0.005	—
Toluene	1.0	0.005	—
trans-1,2-Dichloroethylene	0.1	0.005	—
Trichloroethylene	0.005	0.005	—
Xylenes	10	0.005	—
Chloromethane	—	0.005	0.005
<b>Semi-Volatile Organic Compounds</b>			
bis(2-Ethylhexyl)phthalate	0.006	0.05	—
Chlorinated dibenzo-p-dioxins & dibenzofurans	—	3.5 x 10 <sup>-8</sup>	—
Di-n-butyl phthalate	—	0.05	—
Pentachlorophenol	0.001	0.001	—
Phenol <sup>3</sup>	—	0.001	—
Phenolic compounds (total phenols)	—	0.001	—
Phenols, total chlorinated	—	0.001	—
<b>Metals</b>			
Antimony	0.006	—	—
Arsenic	0.05	0.025	0.05
Barium	2	1	1
Beryllium	0.004	0.003	—

TABLE 5-1

**STATE AND FEDERAL ARARs FOR GROUND WATER**  
**Griffiss AFB, Rome, New York**

Compounds	Federal <sup>a</sup> MCL (mg/L)	State Ground <sup>b</sup> Water Standard (mg/L)	State <sup>c</sup> MCL (mg/L)
Cadmium	0.005	0.01	0.01
Chromium (hexavalent)	-	0.05	-
Chromium (total)	0.1	0.05	0.05
Copper	1.3 (al)	0.2	1 (s)
Cyanide	0.2	0.1	-
Iron	0.3 (s)	0.3	0.3 (s)
Lead	0.015 (al)	0.025	0.05
Manganese	0.05 (s)	0.3	0.3 (s)
Mercury	0.002	0.002	0.002
Nickel	0.1	-	-
Selenium	0.05	0.01	0.01
Silver	-	0.05	0.05
Sodium	-	20	-
Thallium	0.002	-	-
Zinc	5.0 (s)	0.3	5.0 (s)
Primary Organic Contaminant	-	0.005	0.005
Unspecified Organic Contaminant		0.05	

All concentrations are in milligrams per liter.

- a - Drinking Water Regulations and Health Advisories, Office of Water, USEPA, May 1993.
  - b - New York State Department of Environmental Conservation: Water Quality Standards and Guidance Values, November 1991.
  - c - New York State Sanitary Code: Drinking Water Supplies, Subpart 5-1, Public Water Systems, March 11, 1992.
- (s) - Secondary MCL.
  - (al) - Action Level.
  - (t) - Total trihalomethanes

### 5.2.2 State of New York Standards and Guidelines

The state of New York has promulgated both drinking water MCLs and ground-water standards for different use classifications of water. The following sections describe these regulatory standards and guidelines.

5.2.2.1 Drinking Water MCLs - The SDWA requires the states to promulgate drinking water standards that are at least as stringent as the federal MCLs. In addition, the SDWA provides for the states to develop standards that are either more stringent than federal MCLs or to develop standards to regulate chemicals not currently considered in the federal regulations. The state of New York has promulgated regulations that are more stringent than the federal regulations or cover substances not covered by federal regulations. Table 5-1 presents the state of New York Primary and Secondary MCLs for constituents detected at Griffiss AFB.

Under the New York regulations, organic chemicals are designated as either Primary Organic Contaminants (POC) or Unspecified Organic Contaminants (UOC) (NYCRR, 1991). The POC class includes halogenated alkanes, halogenated ethers, halobenzenes and substituted halobenzenes, benzene and alkyl- or nitrogen-substituted benzenes, substituted unsaturated hydrocarbons, and halogenated nonaromatic cyclic hydrocarbons. The New York Primary MCL for this category of compounds is 5 micrograms per liter ( $\mu\text{g}/\text{L}$ ). Carbon tetrachloride is an example of a constituent which is included in this category. The UOC class includes all organic chemicals not classified as POCs. Glycols are an example of UOC compounds. A Primary MCL of 50  $\mu\text{g}/\text{L}$  is applied to these chemicals.

The state of New York has promulgated Secondary MCLs for sulfate and zinc. Secondary MCLs are non-enforceable guidelines established to protect public welfare and may apply to any contaminant in drinking water which adversely affects the odor, taste, or appearance of water.

5.2.2.2 Ground-Water Standards for Class GA Ground Waters - New York has also established standards for ground-water quality that are based on the potential or actual use of ground-water resources. These standards have been promulgated based on the regulatory classification of ground water. Because the ground water in the vicinity of Griffiss AFB is used as a potable water source, the standards for Class GA waters are applicable. New York Class GA waters are defined as fresh ground waters found in the saturated zone of unconsolidated deposits and consolidated rock or bedrock (NYCRR, 1991). The most stringent use of Class GA waters is as a source of potable water supply. Table 5-1 presents the regulatory water quality standards for New York Class GA ground water.

771

TABLE 2-6  
MONITORING WELL LOCATION AND WATER LEVEL INFORMATION  
Griffis AFB, Rome, New York

MONITORING WELL NAME	NORTHING (ft)	EASTING (ft)	TOP OF CASING ELEVATION (ft, MSL)	GROUND-WATER ELEVATION (ft, MSL) DATE MEASURED	GROUND-WATER ELEVATION (ft, MSL) DATE MEASURED	GROUND-WATER ELEVATION (ft, MSL) DATE MEASURED	GROUND-WATER ELEVATION (ft, MSL) DATE MEASURED
100MW-1	11779.71	113634.41	472.30	460.53 /12-1-92	459.53 /3-4-93	460.42 /6-8-93	459.43 /9-14-93
101MW-1	11774.13.15	1132403.48	470.81	458.85 /12-1-92	458.18 /3-3-93	458.68 /6-8-93	458.13 /9-13-93
110MW-1	11774.24.02	1133252.69	471.86	460.34 /12-1-92	459.09 /3-4-93	460.24 /3-4-93	471.86 / (Removed/Destroyed)
B20MW-1	1174962.03	113372.18	467.22	457.89 /12-1-92	457.32 /3-4-93	457.93 /6-8-93	457.61 /9-13-93
301MW-4	1176277.61	1131088.31	475.31	457.64 /12-1-92	456.60 /3-3-93	457.43 /6-8-93	456.56 /9-13-93
B43MW-1	1176316.6	1135543.62	468.68	459.10 /11-30-92	459.10 /3-3-93	458.73 /6-8-93	458.01 /9-13-93
711MW-1	1175061.39	1135708.30	474.80	459.98 /11-30-92	FP /3-3-93	FP /6-7-93	FP /NA
711MW-2	1174971.98	1135703.42	475.66	458.54 /11-30-92	458.02 /3-3-93	458.90 /6-7-93	458.34 /9-14-93
711MW-3	1174964.17	1135609.67	474.73	458.98 /11-30-92	FP /3-3-93	458.98 /NA	FP /NA
711MW-4	1175088.22	1135617.12	464.51	457.60 /12-1-92	457.11 /3-9-93	457.74 /6-8-93	457.43 /9-13-93
711MW-5	1175648.23	1136414.98	479.19	472.52 /11-30-92	467.39 /3-11-93	472.17 /6-7-93	470.33 /9-14-93
711MW-6	1174939.20	1135649.22	476.60	459.69 /11-30-92	458.99 /3-3-93	460.21 /6-7-93	469.21 /9-14-93
711MW-8	1175043.81	1135754.76	476.89	458.07 /11-30-92	457.54 /3-3-93	457.96 /6-7-93	457.83 /9-14-93
711MW-9	1175066.34	1135803.04	477.16	458.76 /11-30-92	457.94 /3-3-93	461.97 /6-7-93	458.02 /9-14-93
779MW-1	1175671.74	1135767.36	515.63	460.72 /12-1-92	460.87 /3-3-93	462.13 /6-7-93	461.63 /9-13-93
779MW-2	1173649.00	1135780.51	514.64	460.71 /12-1-92	460.65 /3-3-93	462.07 /6-7-93	461.54 /9-13-93
779MW-1	1173422.31	1135928.76	516.51	460.55 /12-1-92	460.87 /3-3-93	461.77 /6-7-93	461.58 /9-13-93
779MW-2	1173492.70	1135938.36	515.67	460.78 /12-1-92	462.32 /3-3-93	462.02 /6-7-93	461.68 /9-13-93
779MW-3	1173416.16	1136020.89	515.74	460.75 /12-1-92	461.10 /3-3-93	461.99 /6-7-93	461.82 /9-13-93
779MW-1	1172995.10	1136379.43	517.27	460.89 /12-1-92	461.09 /3-3-93	462.27 /6-7-93	461.88 /9-13-93
779MW-2	1173066.28	1136392.11	515.29	461.87 /12-1-92	461.94 /3-3-93	463.31 /6-7-93	462.43 /9-13-93
779MW-3	1172990.46	1136469.80	514.66	461.31 /12-1-92	461.26 /3-3-93	462.79 /6-7-93	462.00 /9-13-93
781MW-1	1172760.70	1136629.78	515.71	461.01 /12-1-92	FP /3-3-93	463.33 /6-7-93	FP /NA
781MW-2	1172829.79	1136643.27	515.43	459.67 /12-1-92	460.20 /3-3-93	461.41 /6-7-93	460.78 /9-13-93
781MW-3	1172755.39	1136722.39	515.00	460.87 /12-1-92	461.79 /3-3-93	462.67 /6-7-93	462.11 /9-13-93

CURRENT WELL NUMBER	PROPOSED WELL NUMBER	BENTONITE SEAL LENGTH/INTERVAL (FEET)	LOGGED STICK-UP (FEET)	SURVEYED STICK-UP (FEET)	SCREENED LITHOLOGY TYPE	SLOT SIZE	CASING MATERIAL
TF3-MW28	TF3-MW9	1 (3-4)	FLUSH		FN CRS SND, GVL, SLTY SND	20	PVC SCHED. 40
210-MW19	B210-MW1	1 (7-8)	1.4	1.53	FN CRS SND; GVL, SLT, CLY	20	PVC SCHED. 40
210-MW20	B210-MW2	1 (8-9)	2	1.15	FN CRS SND, SM SLT, TR GVL	20	PVC
20-MW1	B20-MW1	2 AT GRADE		2.44	NO LOG PROVIDED		PVC SCHED. 40
FDA-MW1	FDA-MW1	2 AT GRADE		2.37	NO LOG PROVIDED		PVC SCHED. 40
T9-MW1	T9SA-MW1	2 AT GRADE		2.49	NO LOG PROVIDED		PVC SCHED. 40
T9-MW2	T9SA-MW2	2 AT GRADE		2.66	NO LOG PROVIDED		PVC SCHED. 40
T9-MW3	T9SA-MW3	2 AT GRADE		2.72	NO LOG PROVIDED		PVC SCHED. 40
T9-MW4	T9SA-MW4	2 AT GRADE		2.24	NO LOG PROVIDED		PVC SCHED. 40
43-MW1	B43-MW1	2 AT GRADE		2.36	NO LOG PROVIDED		PVC SCHED. 40
MW-8	LF5-MW1	2 (5-7)	5.9	1.9	MD FN SND; SLT	20	PVC
MW-9	LF6-MW1	2 (6-8)	2.4	1.72	MD FN SND; SLT	20	PVC
TMC-USGS-1	TMC-MW1			2.9	GVL, CLN SND		PVC
TMC-USGS-2	TMC-MW2			2.5	CRS SLTY CLYY SND		PVC
TMC-USGS-3	TMC-MW3			3.32	VFN SND		PVC
TMC-USGS-4	TMC-MW4			3.3	MD CRS SND		PVC
TMC-USGS-6	TMC-MW6			2.54	FN MD SND		PVC
TMC-USGS-7	TMC-MW7			2.32	FN CRS SND		PVC
TMC-USGS-8	TMC-MW8			2.92	MD CRS SND, GVL, FN SND		PVC
TMC-USGS-10	TMC-MW10			3.54	CLN SND		PVC
771-MW1	B771-MW1	2 (5-7)		1.2	FN, MD SND; SLT, GVL	10	PVC
771-MW2	B771-MW2	2 (4-6)		1.57	FN, MD SND; SLT, GVL	10	PVC
771-MW3	B771-MW3	2 (5-7)		1.43	FN, MD SND; SLT, GVL	10	PVC
773-MW1	B773-MW1	2		1.54	FN, MD SND; MD GVL	10	PVC
773-MW2	B773-MW2	2		1.56	FN, MD SND; MD GVL	10	PVC
773-MW3	B773-MW3	2		1.44	FN, MD SND; MD GVL	10	PVC
775-MW1	B775-MW1	2		1.79	FN, MD SND; TR FN, CRS GVL	10	PVC
775-MW2	B775-MW2	2		1.6	FN, MD SND; TR MD GVL, SLT	10	PVC
775-MW3	B775-MW3	2		1.95	FN, MD SND; TR SLT, FN GVL	10	PVC
779-MW1	B779-MW1	2		1.21	FN, MD GVL; TR MD GVL, SLT	10	PVC
779-MW2	B779-MW2	2		0.92	FN, MD SND; TR MD GVL, SLT	10	PVC
779-MW3	B779-MW3	2		0.93	FN, MD SND; TR MD GVL, SLT	10	PVC
781-MW1	B781-MW1	2		1.22	FN, MD SND; TR SLT, MD GVL	10	PVC
781-MW2	B781-MW2	2		1.81	FN, MD SND; TR MD GVL, SLT	10	PVC
781-MW3	B781-MW3	2		1.02	FN, MD SND, TR MD GVL, SLT	20	PVC SCHED. 40
100-MW1	B100-MW1	3.3 (1.5-4.8)	FLUSH	-0.45	SND, FN CRS GVL		
786-MW1	B786-MW1			2.5			

WELLS DESTROYED OR NOT LOCATED:

SMC-USGS-6	SMC-MW6				MD FN SND, SLTY SND, SM GVL		
SMC-USGS-4	SMC-MW4				MD FN SND, SM GVL		
TF3-MW4	TF3-MW4	1 FLUSH			CRS FN SND, SM FN GVL, SLT	20	PVC SCHED. 40
TF3-MW7	TF3-MW7	1 FLUSH			FN SND, SLT	20	PVC SCHED. 40
TMC-MW5	TMC-MW5				SND, GVL; TR SLT, CLY		
TMC-MW9	TMC-MW9				FN MD SND		PVC
TMC-MW11	TMC-MW11				FN MD SND		PVC
TMC-MW12	TMC-MW12				MD CRS SND, GVL		
TMC-MW13	TMC-MW13						

CURRENT WELL NUMBER	PROPOSED WELL NUMBER	GAFB AREA	DATE INSTALLED	CONTRACTOR OR AGENCY	GROUND ELEVATION (FEET)	CASING ELEVATION (FEET)	BORE DIAMETER (INCHES)	CASING DIAMETER (INCHES)	BORE DEPTH (FEET)	WELL DEPTH (FEET)	SCREEN LENGTH (FEET)	BGS (FEET)	WELL SCREEN SAND PACK LENGTH (FEET)	SAND INTERV. (FEET)
210-MW19	8210-MW1	BLDG. 210	07/16/84	WESTON	474.83	476.36	8.00	4.00	32.00	30.00	20.00	10-30	24.00	
210-MW20	8210-MW2	BLDG. 210	07/11/84	WESTON	474.86	476.01	8.00	4.00	32.00	30.00	20.00	10-30	23.00	
20-MW1	820-MW1	BLDG. 20	10/22/86	HYDRO-ENR. TECH	464.75	467.19	8.25	4.00	22.00	20.00				
FDA-MW1	FDA-MW1	FIRE DEMO AREA	10/23/86	HYDRO-ENR. TECH	476.82	479.19	8.25	4.00	20.60	20.00				
T9-MW1	T9SA-MW1	T-9 STORAGE AREA	10/15/86	HYDRO-ENR. TECH	463.03	465.52	8.25	4.00	12.60	12.60				
T9-MW2	T9SA-MW2	T-9 STORAGE AREA	10/17/86	HYDRO-ENR. TECH	463.62	466.28	8.25	4.00	17.60	17.00				
T9-MW3	T9SA-MW3	T-9 STORAGE AREA	10/17/86	HYDRO-ENR. TECH	462.78	465.50	8.25	4.00	21.60	21.00				
T9-MW4	T9SA-MW4	T-9 STORAGE AREA	10/20/86	HYDRO-ENR. TECH	464.09	466.33	8.25	4.00	15.00	15.00				
43-MW1	843-MW1	BLDG. 43	10/08/86	HYDRO-ENR. TECH	466.29	468.26	8.25	4.00	22.00	22.00				
MW-8	LF5-MW1	LANDFILL 5	12/18/81	WESTON	460.76	468.65	10.00	4.00	35.00	30.00	10.00	20-30	28.00	
MW-9	LF6-MW1	LANDFILL 6	12/18/81	WESTON	455.50	462.66	10.00	4.00	35.00	28.00	10.00	18-28	27.00	
TMC-USGS-1	TMC-MW1	TMC AREA	03/10/87	USGS	454.91	457.22	2.00	2.00	22.50	2.50	19.0-21.5			
TMC-USGS-2	TMC-MW2	TMC AREA	03/10/87	USGS	452.61	457.81	2.00	2.00	31.00	2.50	24-26.5			
TMC-USGS-3	TMC-MW3	TMC AREA	03/11/87	USGS	471.88	455.11	2.00	2.00	29.50	2.50	24-26.5			
TMC-USGS-4	TMC-MW4	TMC AREA	03/11/87	USGS	473.87	475.20	2.00	2.00	26.00	2.50	23.5-26			
TMC-USGS-6	TMC-MW6	TMC AREA	04/27/87	USGS	473.43	477.17	2.00	2.00	30.50	2.50	28-30.5			
TMC-USGS-7	TMC-MW7	TMC AREA	04/27/87	USGS	465.50	475.97	2.00	2.00	27.00	2.50	22.5-25			
TMC-USGS-8	TMC-MW8	TMC AREA	04/27/87	USGS	466.73	467.82	2.00	2.00	27.00	2.50	24.5-27			
TMC-USGS-10	TMC-MW10	TMC AREA	04/29/87	USGS	459.10	469.65	2.00	2.00	23.00	2.50	20-22.5			
771-MW1	8771-MW1	BLDG. 771	05/23/89	PARRATT-WOLFF	473.50	462.64	7.50	2.00	2.00	24.00	15.00	9-24	17.00	
771-MW2	8771-MW2	BLDG. 771	05/23/89	PARRATT-WOLFF	473.95	474.70	7.50	2.00	2.00	23.50	15.00	8.5-23.5	17.50	
771-MW3	8771-MW3	BLDG. 771	05/23/89	PARRATT-WOLFF	473.19	475.52	7.50	2.00	2.00	24.00	15.00	9-24	17.00	
773-MW1	8773-MW1	BLDG. 773	05/17/89	PARRATT-WOLFF	514.02	474.62	7.50	2.00	2.00	63.50	15.00		17.00	
773-MW2	8773-MW2	BLDG. 773	05/17/89	PARRATT-WOLFF	513.04	515.56	7.50	2.00	2.00	65.00	15.00		17.00	
773-MW3	8773-MW3	BLDG. 773	05/17/89	PARRATT-WOLFF	512.97	514.60	7.50	2.00	2.00	64.00	15.00		17.00	
775-MW1	8775-MW1	BLDG. 775	05/18/89	PARRATT-WOLFF	514.66	514.41	7.50	2.00	2.00	65.00	15.00		17.00	
775-MW2	8775-MW2	BLDG. 775	05/19/89	PARRATT-WOLFF	514.02	516.45	7.50	2.00	2.00	65.00	15.00		17.00	
775-MW3	8775-MW3	BLDG. 775	05/18/89	PARRATT-WOLFF	513.75	515.62	7.50	2.00	2.00	64.50	15.00		17.50	
779-MW1	8779-MW1	BLDG. 779	05/19/89	PARRATT-WOLFF	516.02	515.70	7.50	2.00	2.00	65.00	15.00		17.00	
779-MW2	8779-MW2	BLDG. 779	05/22/89	PARRATT-WOLFF	514.32	517.23	7.50	2.00	2.00	65.00	15.00		17.00	
779-MW3	8779-MW3	BLDG. 779	05/22/89	PARRATT-WOLFF	513.68	515.24	7.50	2.00	2.00	64.50	15.00		17.00	
781-MW1	8781-MW1	BLDG. 781	05/25/89	PARRATT-WOLFF	514.46	514.61	7.50	2.00	2.00	64.50	17.00		17.00	
781-MW2	8781-MW2	BLDG. 781	05/24/89	PARRATT-WOLFF	513.77	515.68	7.50	2.00	2.00	65.00	15.00		17.00	
781-MW3	8781-MW3	BLDG. 781	05/24/89	PARRATT-WOLFF	513.94	515.38	7.50	2.00	2.00	69.50	15.00		16.50	
100-MW1	8100-MW1	BLFG. 100	02/07/90	GEOTECH	472.72	514.96	10.25	4.00	25.00	23.80	15.00	6.5-21.5	19.00	4
786-MW1	8786-MW1	BLDG. 786		PARRATT-WOLFF	478.38	472.27								
					480.88									
WELLS DESTROYED OR NOT LOCATED:														
SHC-USGS-6	SMC-MW6	SIX MILE CK.	05/11/87	USGS					23.00		2.00	12-14	5.00	
SHC-USGS-4	SMC-MW4	SIX MILE CK.	05/08/87	USGS					28.00		2.00	25-27	5.00	
TF3-MW4	TF3-MW4	TANK FARM 3	07/12/84	WESTON			8.00	4.00	27.00	25.00	20.00	15-25	21.00	
TF3-MW7	TF3-MW7	TANK FARM 3	07/03/84	WESTON			8.00	4.00	32.00	30.50	20.00	20.5-30.5	21.50	
THC-MW5	THC-MW5	THREE MILE CK.	04/26/87	USGS				2.00	37.00		2.50	31.5-34		
THC-MW9	THC-MW9	THREE MILE CK.	04/29/87	USGS				2.00	47.00		2.50	43.5-46		
THC-MW11	THC-MW11	THREE MILE CK.		USGS				2.00	30.00		2.50	27.5-30		
THC-MW12	THC-MW12	THREE MILE CK.		USGS				2.00	42.00		2.50	39-41.5		
THC-MW13	THC-MW13	THREE MILE CK.		USGS				2.00	42.00		2.50			
?: some uncertainty in value														

Table 4-2 (continued). Measured Groundwater Elevations for the Hydrogeology Study at Griffiss Air Force Base

CURRENT WELL NUMBER	PROPOSED WELL NUMBER	DTW <sup>a</sup> (FT)	ELEVATION (FT AMSL)	DTW (FT)	ELEVATION (FT AMSL)	4/2-3/90		5/1-2/90		10/16-19/90		GROUND ELEVATION (FT AMSL)	CASING ELEVATION (FT AMSL)
						DTM (FT)	ELEVATION (FT AMSL)	DTM (FT)	ELEVATION (FT AMSL)	DTM (FT)	ELEVATION (FT AMSL)		
TF3-MW21	TF3-MW2	13.07	457.90	12.62	458.35	12.70	458.27	12.83	458.14	13.36	457.61	467.27	470.97
TF3-MW22	TF3-MW3	10.39	457.81	9.97	458.23	10.05	458.15	10.17	458.03	10.70	457.50	487.64	488.20
TF3-MW24	TF3-MW5	9.14	457.59	8.67	458.06		468.73	9.97	456.76	9.45	457.28	466.73	466.73
TF3-MW25	TF3-MW6	12.56	457.90	12.13	458.33	12.21	458.25	12.36	458.10	12.87	457.59	467.56	470.46
TF3-MW27	TF3-MW8	12.78	459.56	12.35	459.99	12.23	460.11	12.41	459.93	13.31	459.03	470.40	472.34
TF3-MW28	TF3-MW9	10.67	459.70		459.70	470.37		10.28	460.09	11.32	459.05	470.37	472.34
210-MW19	B210-MW1	18.83	457.53	17.68	458.33	18.07	458.29	18.16	458.20	19.20	457.16	474.83	476.36
210-MW20	B210-MW2	18.42	457.59	9.00	458.19	9.27	457.92	17.81	458.20	19.15	456.86	474.86	476.01
20-MW1	B20-MW1			16.09	463.10	16.31	462.88	9.36	457.83	9.93	457.26	464.75	467.19
FDA-MW1	FDA-MW1	17.42	461.77	4.25	461.27	4.04	461.48	5.08	460.44	10.68	460.51	476.82	479.19
T9-MW1	T9-MW1			5.28	461.00	5.32	460.96	5.99	460.29	10.68	454.83	463.03	465.52
T9-MW2	T9-MW2			5.05	460.45	5.38	460.12	5.75	459.75	5.72	460.56	463.62	466.28
T9-MW3	T9-MW3	5.60	459.90	5.88	460.45	6.04	460.29	6.71	459.62	5.89	459.61	462.78	465.50
T9-MW4	T9-MW4			8.58	460.45	8.84	459.81	6.03	459.41	6.92	458.41	464.09	466.33
43-MW1	B43-MW1	10.00	458.65	6.13	456.53	6.55	456.11	6.62	456.04	7.40	455.26	466.65	468.65
TMC-MW8	LF5-MW1			2.34	454.88	2.46	454.76	2.57	454.65	3.42	453.80	460.76	462.86
TMC-MW9	LF6-MW1			5.74	452.07	6.40	451.41	6.66	451.15	7.91	449.90	454.91	457.81
TMC-USGS-1	TMC-MW1	6.94	450.87	4.27	450.84	4.55	451.11	4.31	450.80	5.22	448.89	452.61	455.11
TMC-USGS-2	TMC-MW2	4.88	450.23	19.07	456.13	18.35	456.85	18.10	457.10	19.31	455.89	471.88	475.20
TMC-USGS-3	TMC-MW3	19.31	455.89	20.27	456.93	19.53	457.64	19.50	457.67	20.75	456.42	473.87	477.17
TMC-USGS-4	TMC-MW4	20.62	456.55	18.95	457.02	18.39	457.58	18.33	457.64	19.60	456.37	473.43	475.97
TMC-USGS-6	TMC-MW6	19.24	456.73	10.66	457.16	10.96	456.86	11.05	456.77	11.90	455.92	465.50	467.82
TMC-USGS-7	TMC-MW7	11.26	456.56	14.36	455.29	14.61	455.04	14.64	455.01	14.90	454.75	466.73	469.65
TMC-USGS-8	TMC-MW8	14.67	454.98		455.29	3.54	459.10	6.00	456.84	4.58	458.06	459.10	462.64
TMC-USGS-10	TMC-MW10	3.25	459.39	16.95	457.67	16.70/17.00 <sup>b</sup>	474.62	17.10	457.52	21.54	453.08	473.19	474.62
771-MW1	B771-MW1			17.45	458.07	17.39	458.13	16.71	458.81	17.75	457.77	473.95	475.52
771-MW2	B771-MW2			20.85	453.85	14.82/21.30 <sup>b</sup>	474.70	21.07		18.35	456.35	473.50	474.70
771-MW3	B771-MW3			55.09	460.47	54.81	460.75	54.48	461.08	54.76	460.80	514.02	515.56
773-MW1	B773-MW1			54.06	460.54	53.77	460.83	53.45	461.15	53.77	460.83	513.04	514.60
773-MW2	B773-MW2			53.89	460.52	53.59	460.82	53.27	461.14	53.56	460.85	512.97	514.41
773-MW3	B773-MW3			56.24	460.21	56.10	460.35	55.82	460.83	55.63	460.82	514.66	516.45
775-MW1	B775-MW1			55.12	460.50	54.98	460.64	54.66	460.96	54.67	460.95	514.02	515.62
775-MW2	B775-MW2			55.34	460.36	55.20	460.50	54.93	460.77	54.74	460.96	513.75	515.70
775-MW3	B775-MW3			56.60	460.63	56.52	460.71	56.13	461.10	55.89	461.34	516.02	517.23
779-MW1	B779-MW1			53.52	461.72	53.40	461.84	53.15	462.09	53.29	461.95	514.32	515.24
779-MW2	B779-MW2			53.66	460.95	53.28	461.33	52.88	461.73	53.26	461.35	513.88	514.61
779-MW3	B779-MW3			55.09	460.59	55.08	460.60	54.83	460.85	54.66	461.02	514.46	515.68
781-MW1	B781-MW1			55.90	459.48	55.88	459.70	55.29	460.09	55.38	460.00	513.74	515.38
781-MW2	B781-MW2			54.20	460.76	54.16	460.80	54.05	460.91	54.66	460.30	513.99	514.96
781-MW3	B781-MW3			11.48	460.79	11.25	461.02	11.48	460.79	12.87	459.40	472.72	472.27
100-MW1	B100-MW1	22.00	458.88	20.77	460.11	20.41	460.47	19.66	461.22	20.90	459.98	478.38	480.88
786-MW1	B786-MW1												

<sup>a</sup> DTW = depth to water; <sup>b</sup> Free product level/water level

**LAW ENVIRONMENTAL, INC.**  
**GOVERNMENT SERVICES DIVISION**  
**TEST BORING RECORD**

BORING NUMBER 771-MW4  
 JOB NUMBER 11-1564  
 DATE STARTED 12-11-91  
 DATE COMPLETED 12-12-91  
 DRILLED BY B. WATERS-PARRATT WOLFF  
 LOGGED BY D. SANDERS-LAW ENVIRONMENTAL  
 CHECKED BY \_\_\_\_\_

REMARKS: PAGE 1 OF 1  
 INTERIM REMOVAL ACTION DESIGN PUMPHOUSE #5  
 VERTICAL SCALE: APPROX. 1" = 4'

ELEV. IN FEET	DEPTH IN FEET	DESCRIPTION	MONITORING WELL CONSTRUCTION	SYMBOLS	LAB TESTS	SPT N VALUE
	0.5	Topsoil				
	0.5 - 2.0	Medium dense brown (2.5 YR, 3/4) fine to medium silty SAND (SM); with gravel				18
	2.0 - 3.5					
	3.5 - 4.9	Medium dense dark reddish gray (5 YR, 4/2) fine to medium silty SAND (SM); moist; petroleum odor				
	4.9 - 6.0					
	6.0 - 10.0	Hard dark gray (5 YR, 4/1) CLAY and SILT (CL-ML); some medium to coarse sand; gray rock fragments; petroleum odor				11
	10.0 - 12.5					
	12.5 - 19.5	<u>Alluvium</u> - Firm dark gray and orange-brown gravel (5 YR, 4/1) in a gray medium to coarse silty SAND matrix (SM); petroleum odor				21
	19.5 - 19.9	Very stiff gray (10 YR, 5/1) SILT and CLAY (ML-CL); some medium to coarse sand; gravel	CAVE-IN			21
	19.9 - 25.0					
	25.0	Boring Terminated				

**LAW ENVIRONMENTAL, INC.**  
**GOVERNMENT SERVICES DIVISION**  
**TEST BORING RECORD**

BORING NUMBER 771-MW5  
 JOB NUMBER 11-1564  
 DATE STARTED 12-12-91  
 DATE COMPLETED 12-12-91  
 DRILLED BY B. WATERS-PARRATT WOLFF  
 LOGGED BY D. SANDERS-LAW ENVIRONMENTAL  
 CHECKED BY \_\_\_\_\_

REMARKS: PAGE 1 OF 1  
 INTERIM REMOVAL ACTION DESIGN PUMPHOUSE #5  
 VERTICAL SCALE: APPROX. 1" = 4'

ELEV. IN FEET	DEPTH IN FEET	DESCRIPTION	MONITORING WELL CONSTRUCTION	SYM-BOLS	LAB TESTS	SPT N VALUE
+2.0						
		GROUND SURFACE				
0.0	0.5	TOPSOIL	[Pattern]			11
	2.0	Medium dense dark gray (7.5 YR, 4/4) fine to medium silty SAND (SM)	[Pattern]			
	3.5	-----				
	4.9	Dense dark gray (10 YR, 4/1) fine to medium silty SAND); rock fragments	[Pattern]			42
	9.0	-----				72
	10.0	Very dense dark gray (10 YR, 4/1) fine to medium silty SAND (SM), some clay; moist	[Pattern]	[Symbol]		
	10.5	Very dense dark brown to brown (7.5 YR, 4/3) fine to medium silty SAND (SM); moist	[Pattern]			
	12.0	Very stiff dark gray and yellow (5 YR, 4/1) fine to medium sandy CLAY and clayey SAND (CL-SC); silty and gravel; wet	[Pattern]			17
	16.5	Medium dense dark brown to brown (7.5 YR, 4/3) fine to medium silty SAND (SM); wet	[Pattern]			
	19.9		[Pattern]			17
	22.0	Boring Terminated	CAVE-IN			

**LAW ENVIRONMENTAL, INC.**  
**GOVERNMENT SERVICES DIVISION**  
**TEST BORING RECORD**

BORING NUMBER 771-MW6  
 JOB NUMBER 11-1564  
 DATE STARTED 12-13-91  
 DATE COMPLETED 12-13-91  
 DRILLED BY B. WATERS-PARRATT WOLFF  
 LOGGED BY D. SANDERS-LAW ENVIRONMENTAL  
 CHECKED BY \_\_\_\_\_

REMARKS: PAGE 1 OF 1  
 INTERIM REMOVAL ACTION DESIGN PUMPHOUSE #5  
 VERTICAL SCALE: APPROX. 1" = 4'

ELEV. IN FEET	DEPTH IN FEET	DESCRIPTION	MONITORING WELL CONSTRUCTION	SYM-BOLS	LAB TESTS	SPT N VALUE
+2.0						
		GROUND SURFACE				
	0.0	TOPSOIL				
	0.5	Medium dense dark brown to brown (10 YR, 4/3) fine to medium silty SAND (SM); rock fragments	[Pattern]			11
	4.0	Medium dense dark yellowish brown (10 YR, 4/4) fine to medium silty SAND (SM)	[Pattern]			13
	4.5					
	7.5					
	9.0					
	9.5	Dense dark brown to brown (10 YR, 4/3) fine to medium silty SAND; gravel; moist	[Pattern]			37
	15.0					
	16.0	Loose dark brown to brown fine to medium silty SAND (SM); wood pieces and gravel	[Pattern]			6
	20.5					
	20.5	Medium dense dark brown to brown (10 YR, 4/3) fine to medium silty SAND (SM)	[Pattern]			16
	24.5					
	25.0	Boring Terminated	CAVE-IN			

**LAW ENVIRONMENTAL, INC.**  
**GOVERNMENT SERVICES DIVISION**  
**TEST BORING RECORD**

BORING NUMBER <u>771-MW7</u> JOB NUMBER <u>11-1564</u> DATE STARTED <u>12-13-91</u> DATE COMPLETED <u>12-13-91</u> DRILLED BY <u>B. WATERS-PARRATT WOLFF</u> LOGGED BY <u>D. SANDERS-LAW ENVIRONMENTAL</u> CHECKED BY _____	REMARKS: <span style="float: right;">PAGE <u>1</u> OF <u>2</u></span>  INTERIM REMOVAL ACTION DESIGN PUMPHOUSE #5  VERTICAL SCALE: APPROX. 1" = 4'
---	--

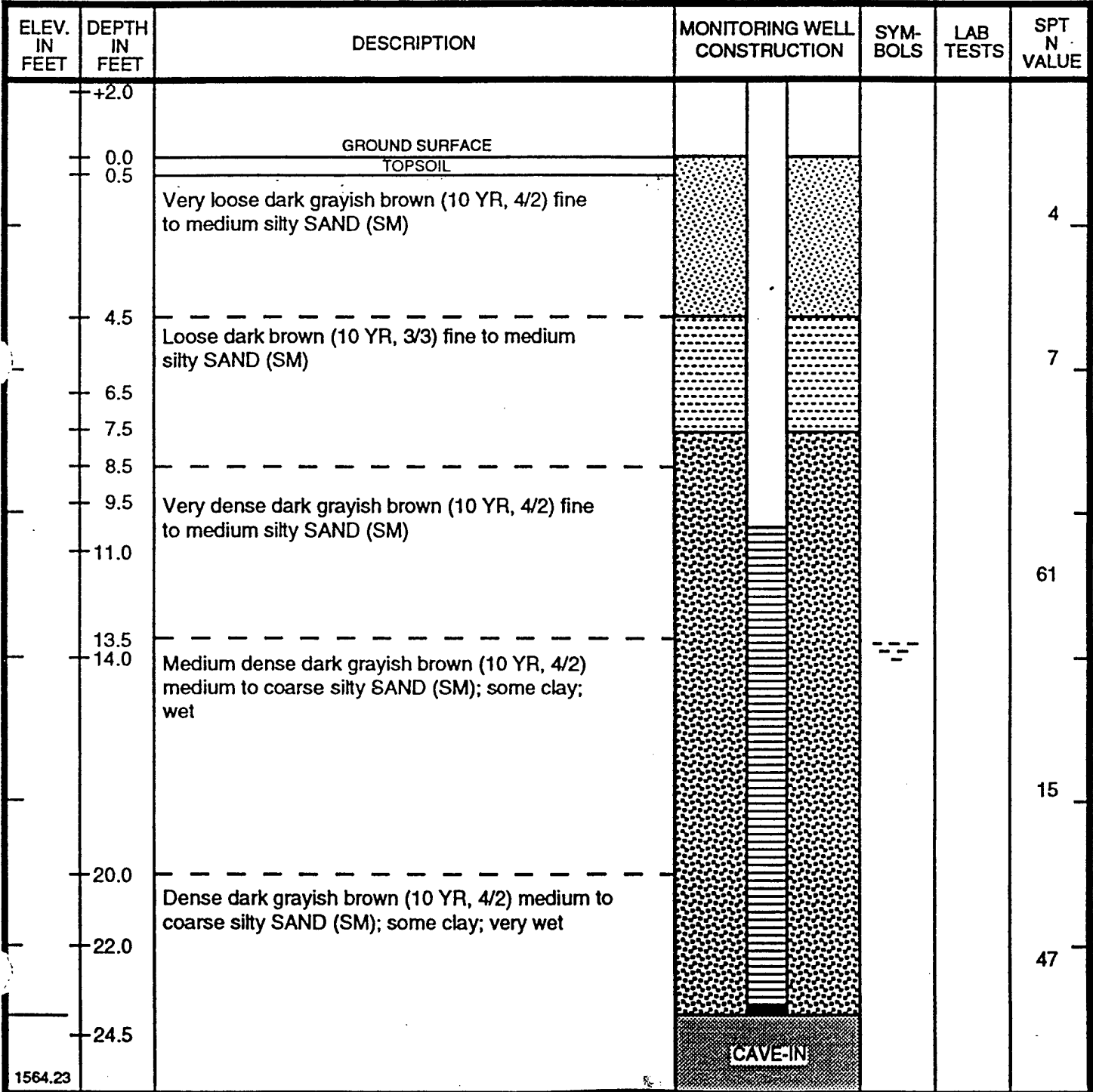



**LAW ENVIRONMENTAL, INC.**  
**GOVERNMENT SERVICES DIVISION**  
**TEST BORING RECORD**

BORING NUMBER 771-MW8  
 JOB NUMBER 11-1564  
 DATE STARTED 12-14-91  
 DATE COMPLETED 12-14-91  
 DRILLED BY B. WATERS-PARRATT WOLFF  
 LOGGED BY D. SANDERS-LAW ENVIRONMENTAL  
 CHECKED BY \_\_\_\_\_

REMARKS: PAGE 1 OF 2  
 INTERIM REMOVAL ACTION DESIGN PUMPHOUSE #5  
 VERTICAL SCALE: APPROX. 1" = 4'

ELEV. IN FEET	DEPTH IN FEET	DESCRIPTION	MONITORING WELL CONSTRUCTION	SYM-BOLS	LAB TESTS	SPT N VALUE
+2.0						
		GROUND SURFACE				
	0.0	TOPSOIL				
	0.5					
	2.0	Medium dense brown to dark brown (10 YR, 4/3) fine to medium silty SAND (SM)				14
	3.5					
	4.5	Medium dense dark grayish brown (10 YR, 4/2) fine to medium silty SAND (SM)				15
	7.5					
	8.0					
	9.9	Very dense grayish brown (10 YR, 5/2) fine to medium silty SAND (SM); rock fragments				79
	14.0					
	16.0	Medium dense brown to dark brown (10 YR, 4/3) medium to coarse silty SAND (SM); wet				14
	19.5	Dense very dark gray (10 YR, 3/1) medium to coarse silty SAND (SM); some weathered rock; wet				46
	24.9		CAVE-IN			



**LAW ENVIRONMENTAL, INC.**  
**GOVERNMENT SERVICES DIVISION**  
**TEST BORING RECORD**

BORING NUMBER 771-MW9  
 JOB NUMBER 11-1564  
 DATE STARTED 12-14-91  
 DATE COMPLETED 12-14-91  
 DRILLED BY B. WATERS-PARRATT WOLFF  
 LOGGED BY D. SANDERS-LAW ENVIRONMENTAL  
 CHECKED BY \_\_\_\_\_

REMARKS: PAGE 1 OF 1

INTERIM REMOVAL ACTION DESIGN PUMPHOUSE #5 -

VERTICAL SCALE: APPROX. 1" = 4'

ELEV. IN FEET	DEPTH IN FEET	DESCRIPTION	MONITORING WELL CONSTRUCTION	SYMBOLS	LAB TESTS	SPT N VALUE
+2.0		GROUND SURFACE				
0.0	0.5	TOPSOIL				
		Medium dense brown to dark brown (10 YR, 4/3) fine to medium silty SAND (SM)				16
4.0	4.5	Dense dark grayish brown (10 YR, 4/2) fine to medium silty SAND (SM)				39
7.5	9.6	Very dense brown (10 YR, 5/3) fine to medium silty SAND (SM)				63
14.0	16.0	Medium dense dark gray (10 YR, 4/1) medium to coarse silty SAND (SM); moist				24
19.0	24.6	Medium dense very dark (10 YR, 3/1) medium to coarse silty SAND (SM); rock fragments; moist				16
			CAVE-IN			

LAW ENVIRONMENTAL, INC.  
GOVERNMENT SERVICES DIVISION

TEST BORING RECORD

BORING NUMBER <u>771-MW9</u> JOB NUMBER <u>11-1564</u> DATE STARTED <u>12-14-91</u> DATE COMPLETED <u>12-14-91</u> DRILLED BY <u>B. WATERS-PARRATT WOLFF</u> LOGGED BY <u>D. SANDERS-LAW ENVIRONMENTAL</u> CHECKED BY _____	REMARKS: <u>PAGE 2 OF 2</u>  INTERIM REMOVAL ACTION DESIGN PUMPHOUSE #5  VERTICAL SCALE: APPROX. 1" = 4'
---	--

ELEV. IN FEET	DEPTH IN FEET	DESCRIPTION	MONITORING WELL CONSTRUCTION	SYM-BOLS	LAB TESTS	SPT N VALUE
			CAVE-IN			
	27.0	Boring Terminated				

# TYPE II MONITORING WELL INSTALLATION DIAGRAM



**LAW ENVIRONMENTAL, INC.**  
 GOVERNMENT SERVICES DIVISION  
 KENNESAW, GEORGIA

JOB NAME GRIFFISS AFB - INTERIM REMOVAL ACTION  
 WELL NO. 771-MW4 JOB NO. 11-1564  
 DATE 12/12/91 TIME 8:30-9:45  
 WELL LOCATION PUMPHOUSE #5-OUTSIDE FENCE

GROUND SURFACE ELEVATION _____	BENTONITE TYPE <u>ENVIROPLUG (MEDIUM) CHIPS</u>
TOP OF SCREEN ELEVATION _____	MANUFACTURER <u>WYO-BEN, INC.(CHIPS)/BIGHORN(POWDER)</u>
REFERENCE POINT ELEVATION _____	CEMENT TYPE <u>PORTLAND CEMENT</u>
TYPE SAND PACK <u>SILICA (WASHED)</u> GRADATION <u>0</u>	MANUFACTURER <u>LA FARGE</u>
SAND PACK MANUFACTURER <u>THE MORIE CO., INC.</u>	BOREHOLE DIAMETER <u>8"</u>
SCREEN MATERIAL <u>PVC - SCHEDULE 40</u>	SCREEN DIAMETER <u>2"</u> SLOT SIZE <u>0.010"</u>
MANUFACTURER <u>TRI-LOC</u>	LAW ENVIRONMENTAL, INC.
RISER MATERIAL <u>PVC - SCHEDULE 40</u>	FIELD REPRESENTATIVE <u>D. SANDERS</u>
MANUFACTURER <u>TRI-LOC</u>	DRILLING CONTRACTOR <u>PARRATT WOLFF</u>
RISER DIAMETER <u>2"</u>	AMOUNT BENTONITE USED <u>3/4 50-LB. BAG/1/2 50-LB. BAG</u>
DRILLING TECHNIQUE <u>HOLLOW STEM AUGERING (HSA)</u>	AMOUNT CEMENT USED <u>3 50-LB. BAGS</u>
AUGER SIZE AND TYPE <u>4.25" I.D. HSA</u>	AMOUNT SAND USED <u>6 50-LB. BAGS</u>
	STATIC WATER DEPTH (after dev.) <u>N/A</u>

(NOT TO SCALE)

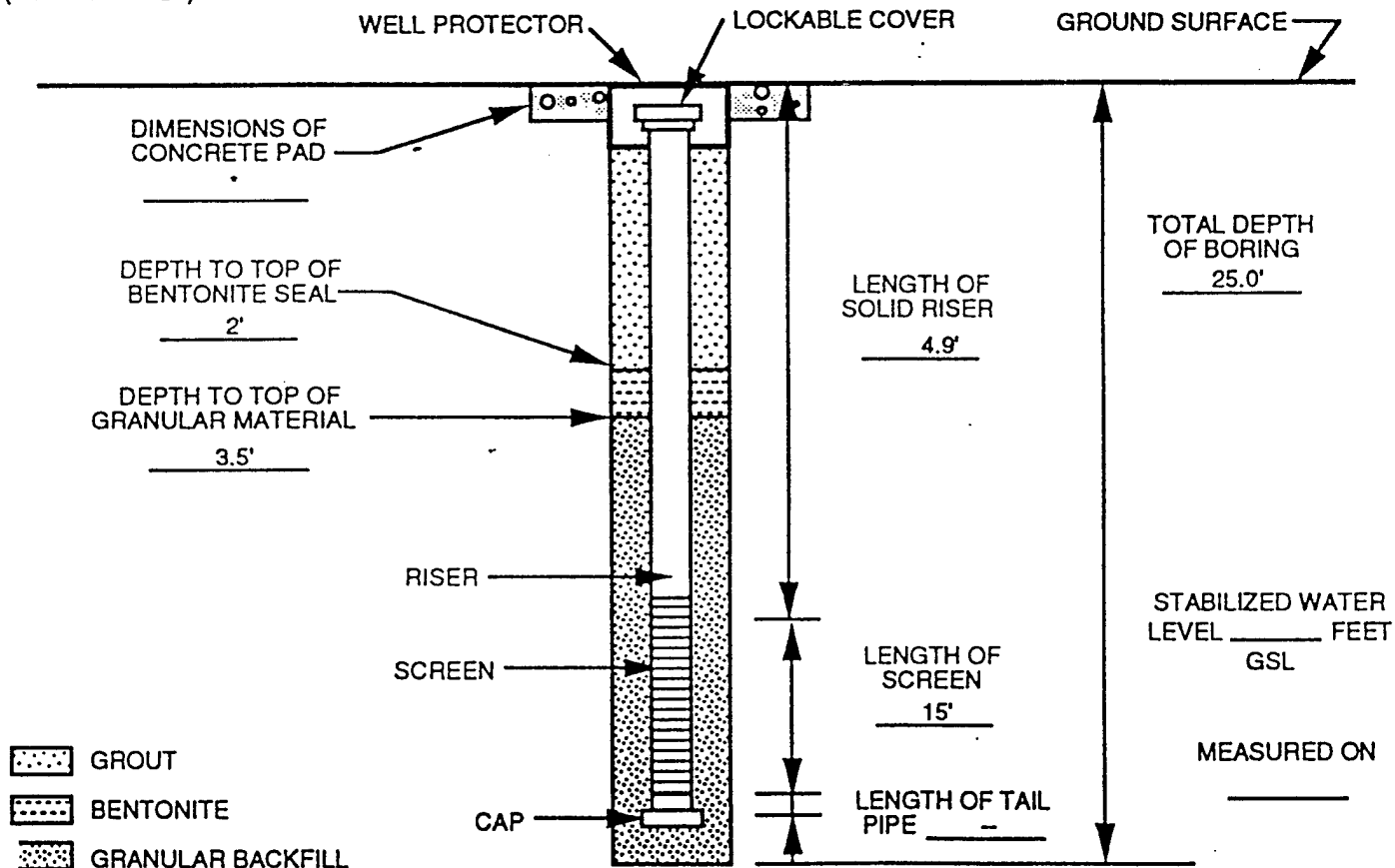

QA / QC

1564.24

INSTALLED BY: BRIAN WATERS INSTALLATION OBSERVED BY: D. SANDERS  
 DISCREPANCIES: GRAVEL MOUND INSTALLED INSTEAD OF A CONCRETE PAD DUE TO THE COLD WEATHER

# MONITORING WELL INSTALLATION DIAGRAM



**LAW ENVIRONMENTAL, INC.**  
 GOVERNMENT SERVICES DIVISION  
 KENNESAW, GEORGIA

JOB NAME GRIFFISS AFB - INTERIM REMOVAL ACTION  
 WELL NO. 771-MW5 JOB NO. 11-1564  
 DATE 12/12/91 TIME 2:40-3:45  
 WELL LOCATION END VALVE PIT NEAR PUMPHOUSE #5

GROUND SURFACE ELEVATION _____ TOP OF SCREEN ELEVATION _____ REFERENCE POINT ELEVATION _____ TYPE SAND PACK <u>SILICA (WASHED)</u> GRADATION <u>0</u> SAND PACK MANUFACTURER <u>THE MORIE CO.</u> SCREEN MATERIAL <u>PVC - SCHEDULE 40</u> MANUFACTURER <u>TRI-LOC</u> RISER MATERIAL <u>PVC - SCHEDULE 40</u> MANUFACTURER <u>TRI-LOC</u> RISER DIAMETER <u>2"</u> DRILLING TECHNIQUE <u>HOLLOW STEM AUGERING (HSA)</u> AUGUR SIZE AND TYPE <u>4.25 I.D. HSA</u> STRATUM _____ (feet) _____	BENTONITE TYPE <u>ENVIROPLUG (MEDIUM) CHIPS</u> MANUFACTURER <u>WYO-BEN. INC. (CHIPS)/BIG HORN (POWDER)</u> CEMENT TYPE <u>PORTLAND CEMENT</u> MANUFACTURER <u>LA FARGE</u> BOREHOLE DIAMETER <u>8"</u> SCREEN DIAMETER <u>2"</u> SLOT SIZE <u>0.010"</u> LAW ENVIRONMENTAL, INC. FIELD REPRESENTATIVE <u>D. SANDERS</u> DRILLING CONTRACTOR <u>PARRATT WOLFF</u> AMOUNT BENTONITE USED <u>2/3 50-LB. BAG/ 1/2 50-LB. BAG</u> AMOUNT CEMENT USED <u>3 50-LB. BAGS</u> AMOUNT SAND USED <u>7.5 50-LB. BAGS</u> STATIC WATER DEPTH (after dev.) <u>18.7'</u>
---	--

(NOT TO SCALE)

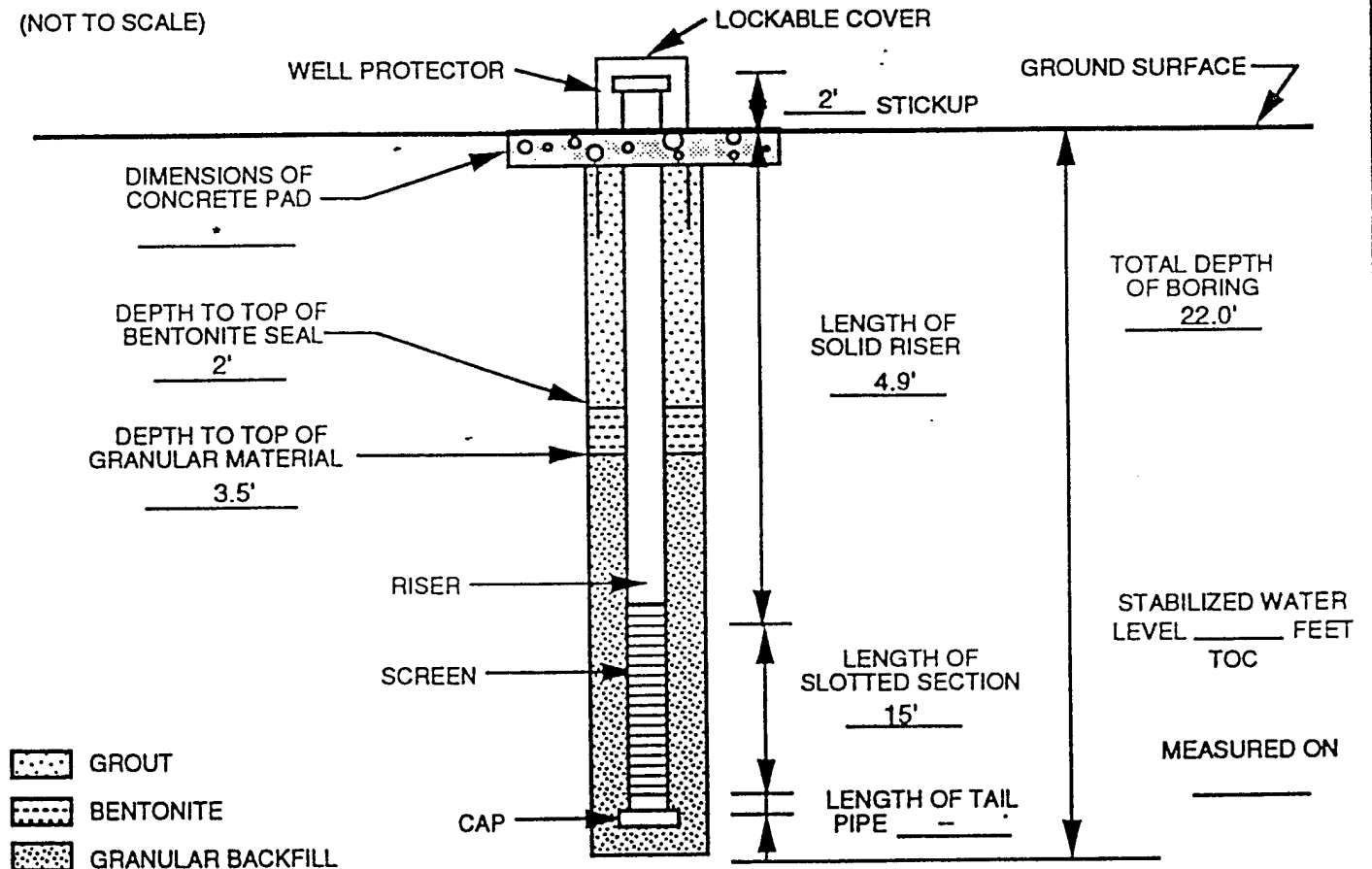

**QA / QC**

1564 24

INSTALLED BY: BRIAN WATERS INSTALLATION OBSERVED BY: D. SANDERS  
 DISCREPANCIES: \*GRAVEL PACK PLACED INSTEAD OF CONCRETE PAD DUE TO COLD WEATHER

# MONITORING WELL INSTALLATION DIAGRAM



**LAW ENVIRONMENTAL, INC.**  
 GOVERNMENT SERVICES DIVISION  
 KENNESAW, GEORGIA

JOB NAME GRIFFISS AFB - INTERIM REMOVAL ACTION  
 WELL NO. 771-MW6 JOB NO. 11-1564  
 DATE 12/13/91 TIME 8:45-10:30  
 WELL LOCATION WEST OF BUILDING AT PUMPHOUSE #5

GROUND SURFACE ELEVATION \_\_\_\_\_

TOP OF SCREEN ELEVATION \_\_\_\_\_

REFERENCE POINT ELEVATION \_\_\_\_\_

TYPE SAND PACK SILICA (WASHED) GRADATION 0  
 SAND PACK MANUFACTURER THE MORIE CO.

SCREEN MATERIAL PVC - SCHEDULE 40  
 MANUFACTURER TRI-LOC

RISER MATERIAL PVC - SCHEDULE 40  
 MANUFACTURER TRI-LOC

RISER DIAMETER 2"

DRILLING TECHNIQUE HOLLOW STEM AUGERING (HSA)  
 AUGUR SIZE AND TYPE 4.25 I.D. HSA

STRATUM \_\_\_\_\_  
 (feet) \_\_\_\_\_

BENTONITE TYPE ENVIROPLUG (MEDIUM) CHIPS  
 MANUFACTURER WYO-BEN, INC. (CHIPS)/BIG HORN (POWDER)

CEMENT TYPE PORTLAND CEMENT  
 MANUFACTURER LA FARGE

BOREHOLE DIAMETER 8"  
 SCREEN DIAMETER 2" SLOT SIZE 0.010"

LAW ENVIRONMENTAL, INC.  
 FIELD REPRESENTATIVE D. SANDERS

DRILLING CONTRACTOR PARRATT WOLFF

AMOUNT BENTONITE USED 2 50-LB. BAGS/ 1/2 50-LB. BAGS

AMOUNT CEMENT USED 3 50-LB. BAGS

AMOUNT SAND USED 9.5 50-LB. BAGS

STATIC WATER DEPTH (after dev.) 18.55'

(NOT TO SCALE)

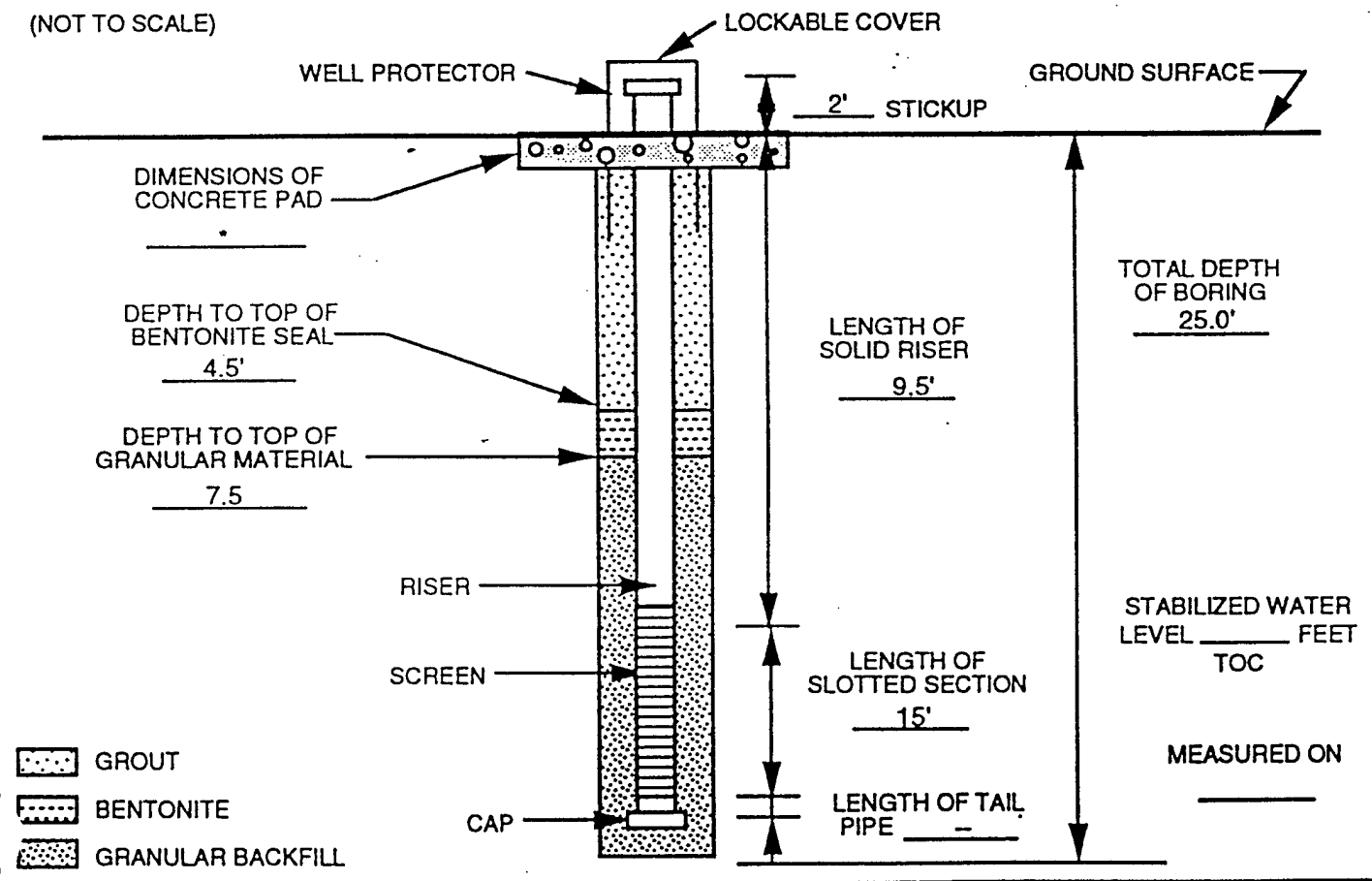

QA / QC

INSTALLED BY: BRIAN WATERS INSTALLATION OBSERVED BY: D. SANDERS  
 DISCREPANCIES: \*GRAVEL PACK PLACED INSTEAD OF CONCRETE PAD DUE TO COLD WEATHER

# MONITORING WELL INSTALLATION DIAGRAM



**LAW ENVIRONMENTAL, INC.**  
 GOVERNMENT SERVICES DIVISION  
 KENNESAW, GEORGIA

JOB NAME GRIFFISS AFB - INTERIM REMOVAL ACTION  
 WELL NO. 771-MW7 JOB NO. 11-1564  
 DATE 12/13/91 TIME 1:00-3:20  
 WELL LOCATION NORTH OF BUILDING AT PUMPHOUSE #5

GROUND SURFACE ELEVATION _____ TOP OF SCREEN ELEVATION _____ REFERENCE POINT ELEVATION _____ TYPE SAND PACK <u>SILICA (WASHED)</u> GRADATION <u>0</u> SAND PACK MANUFACTURER <u>THE MORIE CO.</u> SCREEN MATERIAL <u>PVC - SCHEDULE 40</u> MANUFACTURER <u>TRI-LOC</u> RISER MATERIAL <u>PVC - SCHEDULE 40</u> MANUFACTURER <u>TRI-LOC</u> RISER DIAMETER <u>2"</u> DRILLING TECHNIQUE <u>HOLLOW STEM AUGERING (HSA)</u> AUGUR SIZE AND TYPE <u>4.25 I.D. HSA</u> STRATUM _____ (feet) _____	BENTONITE TYPE <u>PELTONITE (SMALL) PELLETS</u> MANUFACTURER <u>ROCTEST (PELLETS)/BIG HORN (POWDER)</u> CEMENT TYPE <u>PORTLAND CEMENT</u> MANUFACTURER <u>LA FARGE</u> BOREHOLE DIAMETER <u>8"</u> SCREEN DIAMETER <u>2"</u> SLOT SIZE <u>0.010"</u> LAW ENVIRONMENTAL, INC. FIELD REPRESENTATIVE <u>D. SANDERS</u> DRILLING CONTRACTOR <u>PARRATT WOLFF</u> AMOUNT BENTONITE USED <u>2 50-LB BUCKETS/1 50 LB. BAG</u> AMOUNT CEMENT USED <u>3 50-LB. BAGS</u> AMOUNT SAND USED <u>9 50-LB. BAGS</u> STATIC WATER DEPTH (after dev.) <u>N/A</u>
---	--

(NOT TO SCALE)

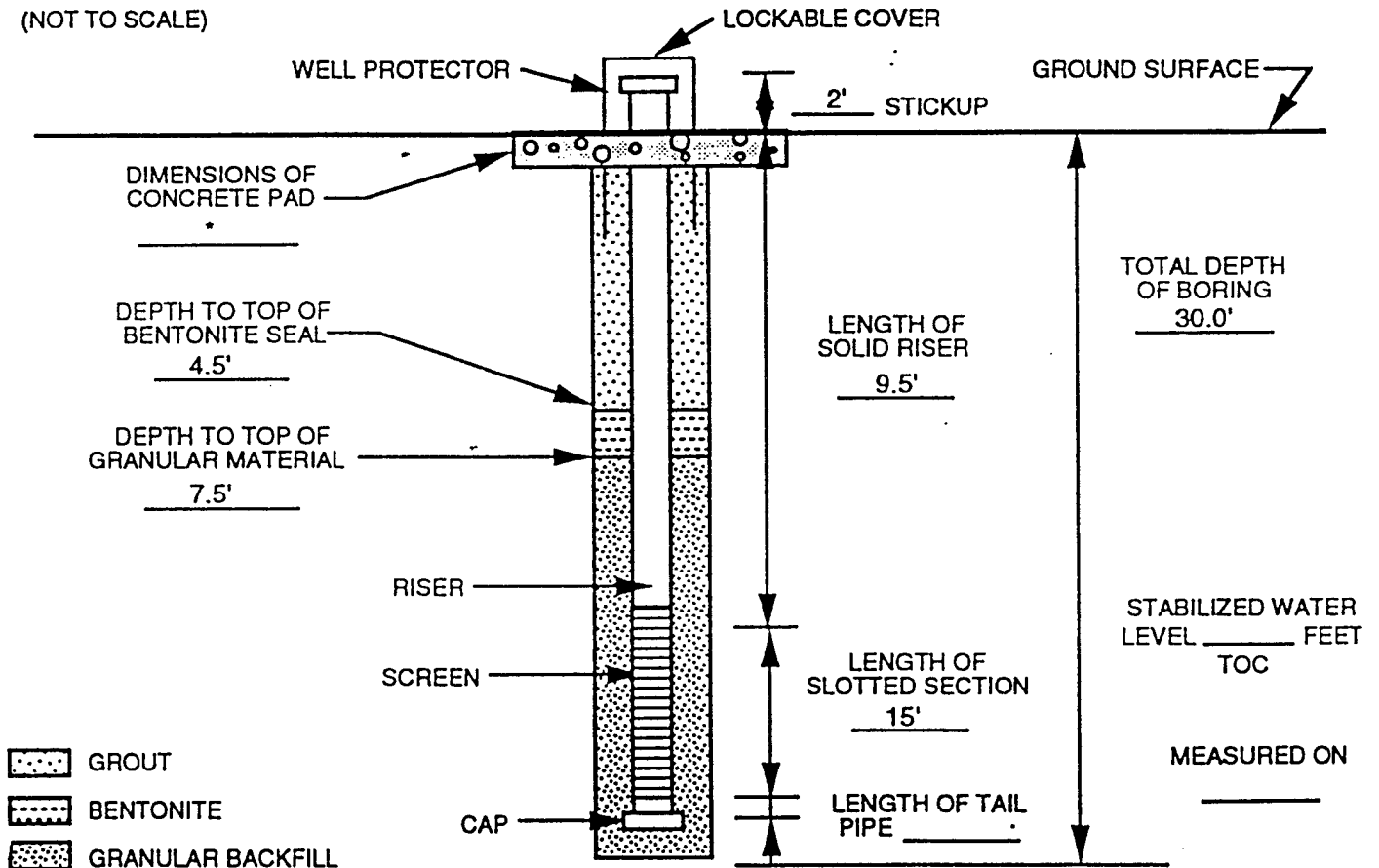

<b>QA / QC</b> 1564.24	INSTALLED BY: <u>BRIAN WATERS</u> INSTALLATION OBSERVED BY: <u>D. SANDERS</u> DISCREPANCIES: <u>*GRAVEL PACK PLACED INSTEAD OF CONCRETE PAD DUE TO COLD WEATHER</u>
---------------------------	--

# MONITORING WELL INSTALLATION DIAGRAM



**LAW ENVIRONMENTAL, INC.**  
GOVERNMENT SERVICES DIVISION  
KENNESAW, GEORGIA

JOB NAME GRIFFISS AFB - INTERIM REMOVAL ACTION  
WELL NO. 771-MW8 JOB NO. 11-1564  
DATE 12/14/91 TIME 8:55-10:45  
WELL LOCATION EAST OF BUILDING AT PUMPHOUSE #5

GROUND SURFACE ELEVATION _____	BENTONITE TYPE <u>ENVIROPLUG (MEDIUM) CHIPS</u>
TOP OF SCREEN ELEVATION _____	MANUFACTURER <u>WYO-BEN. INC. (CHIPS)/BIG HORN (POWDER)</u>
REFERENCE POINT ELEVATION _____	CEMENT TYPE <u>PORTLAND CEMENT</u>
TYPE SAND PACK <u>SILICA (WASHED)</u> GRADATION <u>0</u>	MANUFACTURER <u>LA FARGE</u>
SAND PACK MANUFACTURER <u>THE MORIE CO.</u>	BOREHOLE DIAMETER <u>8"</u>
SCREEN MATERIAL <u>PVC - SCHEDULE 40</u>	SCREEN DIAMETER <u>2"</u> SLOT SIZE <u>0.010"</u>
MANUFACTURER <u>TRI-LOC</u>	LAW ENVIRONMENTAL, INC.
RISER MATERIAL <u>PVC - SCHEDULE 40</u>	FIELD REPRESENTATIVE <u>D. SANDERS</u>
MANUFACTURER <u>TRI-LOC</u>	DRILLING CONTRACTOR <u>PARRATT WOLFF</u>
RISER DIAMETER <u>2"</u>	AMOUNT BENTONITE USED <u>2 50-LB. BAGS/ 1/2 50-LB. BAGS</u>
DRILLING TECHNIQUE <u>HOLLOW STEM AUGERING (HSA)</u>	AMOUNT CEMENT USED <u>3 50-LB. BAGS</u>
AUGUR SIZE AND TYPE <u>4.25 I.D. HSA</u>	AMOUNT SAND USED <u>9 50-LB. BAGS</u>
STRATUM _____	STATIC WATER DEPTH (after dev.) <u>19.02'</u>
(feet) _____	

(NOT TO SCALE)

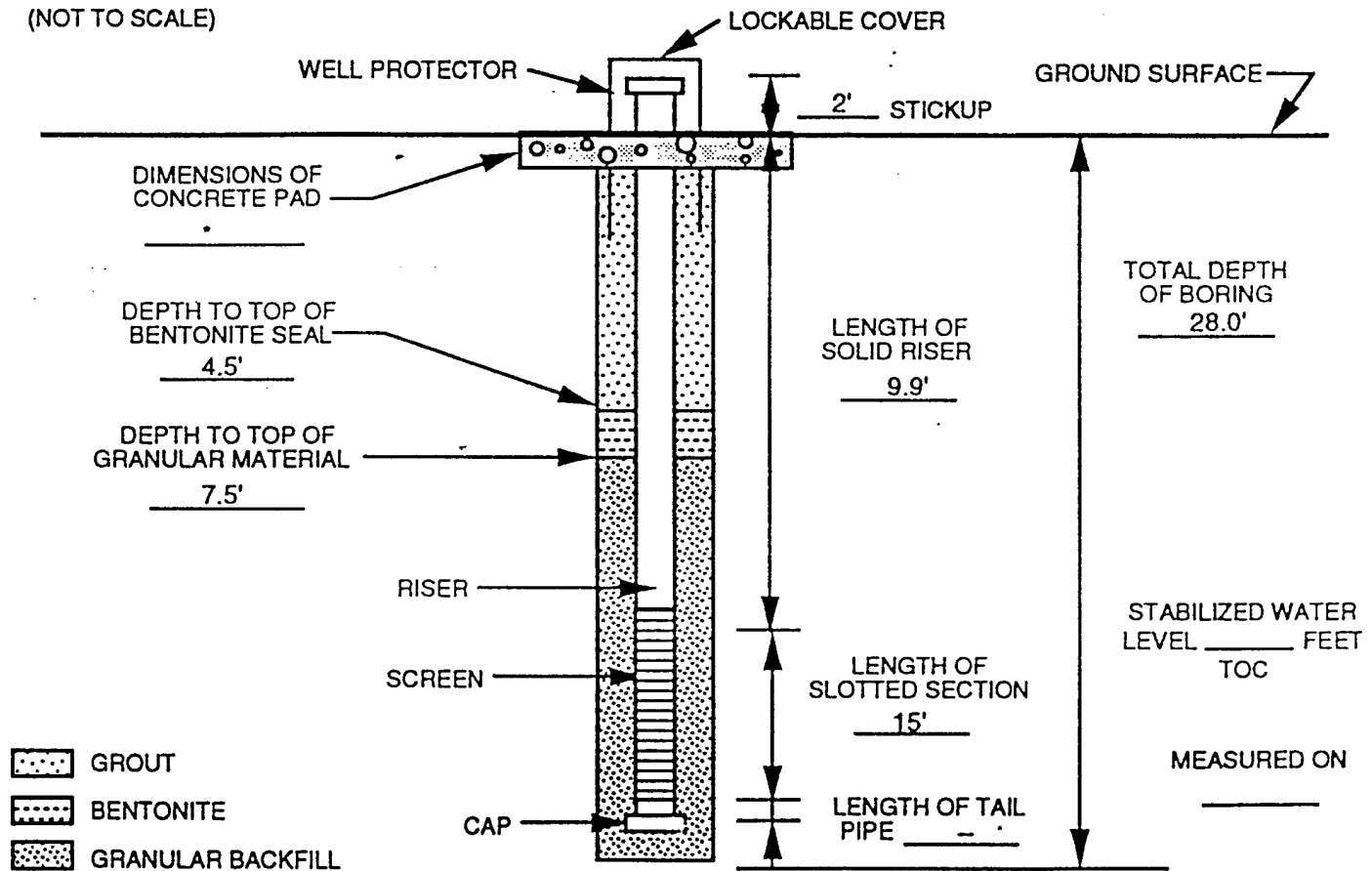

<p><b>QA / QC</b> 1564.24</p>	<p>INSTALLED BY: <u>BRIAN WATERS</u> INSTALLATION OBSERVED BY: <u>D. SANDERS</u> DISCREPANCIES: <u>*GRAVEL PACK PLACED INSTEAD OF CONCRETE PAD DUE TO COLD WEATHER</u></p>
-----------------------------------	--

# MONITORING WELL INSTALLATION DIAGRAM



**LAW ENVIRONMENTAL, INC.**  
 GOVERNMENT SERVICES DIVISION  
 KENNESAW, GEORGIA

JOB NAME GRIFFISS AFB - INTERIM REMOVAL ACTION  
 WELL NO. 771-MW9 JOB NO. 11-1564  
 DATE 11/14/91 TIME 1:15-  
 WELL LOCATION EAST OF BUILDING AT PUMPHOUSE #5.

GROUND SURFACE ELEVATION _____	BENTONITE TYPE <u>ENVIROPLUG (MEDIUM) CHIPS</u>
TOP OF SCREEN ELEVATION _____	MANUFACTURER <u>WYO-BEN, INC. (CHIPS)/BIG HORN (POWDER)</u>
REFERENCE POINT ELEVATION _____	CEMENT TYPE <u>PORTLAND CEMENT</u>
TYPE SAND PACK <u>SILICA (WASHED) GRADATION 0</u>	MANUFACTURER <u>LA FARGE</u>
SAND PACK MANUFACTURER <u>THE MORIE CO.</u>	BOREHOLE DIAMETER <u>8"</u>
SCREEN MATERIAL <u>PVC - SCHEDULE 40</u>	SCREEN DIAMETER <u>2"</u> SLOT SIZE <u>0.010"</u>
MANUFACTURER <u>TRI-LOC</u>	LAW ENVIRONMENTAL, INC.
RISER MATERIAL <u>PVC - SCHEDULE 40</u>	FIELD REPRESENTATIVE <u>D. SANDERS</u>
MANUFACTURER <u>TRI-LOC</u>	DRILLING CONTRACTOR <u>PARRATT WOLFF</u>
RISER DIAMETER <u>2"</u>	AMOUNT BENTONITE USED <u>2 50-LB. BAGS/ 1/2 50-LB. BAGS</u>
DRILLING TECHNIQUE <u>HOLLOW STEM AUGERING (HSA)</u>	AMOUNT CEMENT USED <u>3 50-LB. BAGS</u>
AUGUR SIZE AND TYPE <u>4.25 I.D. HSA</u>	AMOUNT SAND USED <u>10 50-LB. BAGS</u>
STRATUM _____	STATIC WATER DEPTH (after dev.) <u>19.45'</u>
(feet) _____	

(NOT TO SCALE)

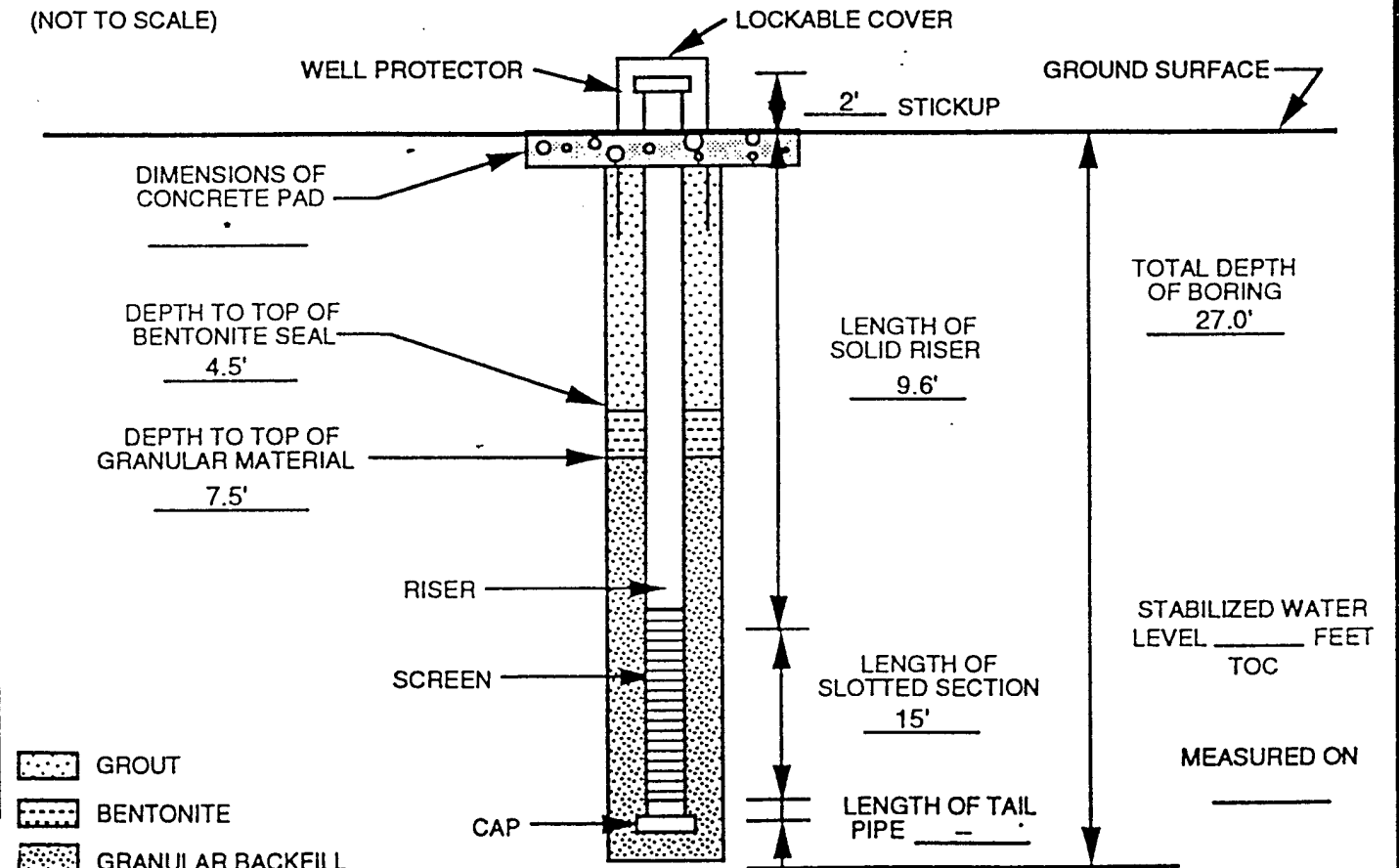

**QA / QC**      INSTALLED BY: BRIAN WATERS      INSTALLATION OBSERVED BY: D. SANDERS  
 1564 24      DISCREPANCIES: \*GRAVEL PACK PLACED INSTEAD OF CONCRETE PAD DUE TO COLD WEATHER