

LOAN DOCUMENT

PHOTOGRAPH THIS SHEET

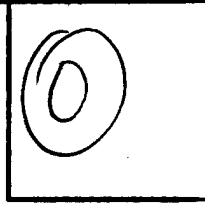

INVENTORY

DTIC ACCESSION NUMBER

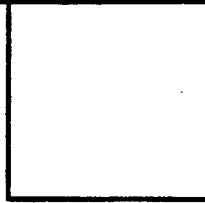

LEVEL

2 Parts
Installation Restoration Program
DOCUMENT IDENTIFICATION
Feb 93

DISTRIBUTION STATEMENT A
Approved for Public Release
Distribution Unlimited

DISTRIBUTION STATEMENT

| |
|--|
| |
|--|

DATE ACCESSIONED

| |
|--|
| |
|--|

DATE RETURNED

| |
|--|
| |
|--|

REGISTERED OR CERTIFIED NUMBER

| | |
|--------------------|--|
| ACCESSION FOR | |
| NTIS | GRAM <input checked="" type="checkbox"/> |
| DTIC | TRAC <input type="checkbox"/> |
| UNANNOUNCED | <input type="checkbox"/> |
| JUSTIFICATION | <input type="checkbox"/> |
| | |
| BY | |
| DISTRIBUTION/ | |
| AVAILABILITY CODES | |
| DISTRIBUTION | AVAILABILITY AND/OR SPECIAL |
| A-1 | |

DISTRIBUTION STAMP

| |
|--------------|
| 20001122 048 |
|--------------|

DATE RECEIVED IN DTIC

PHOTOGRAPH THIS SHEET AND RETURN TO DTIC-FDAC

H
A
N
D
L
E

W
I
T
H

C
A
R
E

PART I
Bioventing Pilot Test Work Plan for
INSTALLATION RESTORATION PROGRAM
SITES 3 AND 18

Fire Protection Training Area No. 1 (Site 3)
Bulk Fuel Storage Area (Site 18)
BEALE AIR FORCE BASE, CALIFORNIA

DRAFT PART II
Draft Interim Pilot Test Results for
INSTALLATION RESTORATION PROGRAM
SITES 3 AND 18

Fire Protection Training Area No. 1 (Site 3)
Bulk Fuel Storage Area (Site 18)
BEALE AIR FORCE BASE, CALIFORNIA

Prepared for
Air Force Center for Environmental Excellence
Brooks AFB, Texas
and Beale Air Force Base, California

February 1993

Prepared by
ENGINEERING-SCIENCE, INC.
DESIGN • RESEARCH • PLANNING
1301 MARINA VILLAGE PARKWAY, ALAMEDA, CA 94501 • 510/769-0100
OFFICES IN PRINCIPAL CITIES
30-20

ENGINEERING-SCIENCE
ES

**DEFENSE TECHNICAL INFORMATION CENTER
REQUEST FOR SCIENTIFIC AND TECHNICAL REPORTS**

Title AFCEE Collection

| | | |
|---|--------------------------------|---------------------|
| 1. Report Availability (Please check one box) <input checked="" type="checkbox"/> This report is available. Complete sections 2a - 2f. <input type="checkbox"/> This report is not available. Complete section 3. | 2a. Number of Copies Forwarded | 2b. Forwarding Date |
| | <u>1 each</u> | <u>July/2000</u> |

2c. Distribution Statement (Please check ONE box)

DoD Directive 5230.24, "Distribution Statements on Technical Documents," 18 Mar 87, contains seven distribution statements, as described briefly below. Technical documents MUST be assigned a distribution statement.

DISTRIBUTION STATEMENT A: Approved for public release. Distribution is unlimited.

DISTRIBUTION STATEMENT B: Distribution authorized to U.S. Government Agencies only.

DISTRIBUTION STATEMENT C: Distribution authorized to U.S. Government Agencies and their contractors.

DISTRIBUTION STATEMENT D: Distribution authorized to U.S. Department of Defense (DoD) and U.S DoD contractors only.

DISTRIBUTION STATEMENT E: Distribution authorized to U.S. Department of Defense (DoD) components only.

DISTRIBUTION STATEMENT F: Further dissemination only as directed by the controlling DoD office indicated below or by higher authority.

DISTRIBUTION STATEMENT X: Distribution authorized to U.S. Government agencies and private individuals or enterprises eligible to obtain export-controlled technical data in accordance with DoD Directive 5230.25, Withholding of Unclassified Technical Data from Public Disclosure, 6 Nov 84.

2d. Reason For the Above Distribution Statement (in accordance with DoD Directive 5230.24)

| | |
|---|--|
| 2e. Controlling Office <u>HQ AFCEE</u> | 2f. Date of Distribution Statement Determination <u>15 Nov 2000</u> |
|---|--|

3. This report is NOT forwarded for the following reasons. (Please check appropriate box)

It was previously forwarded to DTIC on (date) and the AD number is

It will be published at a later date. Enter approximate date if known.

In accordance with the provisions of DoD Directive 3200.12, the requested document is not supplied because:
.....
.....

| | |
|---|---|
| Print or Type Name <u>Laura Peña</u> | Signature <u>Laura Peña</u> |
| Telephone <u>210-536-1431</u> | (For DTIC Use Only) AQ Number <u>M01-01-0333</u> |

PART I

Bioventing Pilot Test Work Plan for

INSTALLATION RESTORATION PROGRAM SITES 3 AND 18

**Fire Protection Training Area No. 1 (Site 3)
Bulk Fuel Storage Area (Site 18)
BEALE AIR FORCE BASE, CALIFORNIA**

Prepared for

**Air Force Center for Environmental Excellence
Brooks AFB, Texas
and
Beale Air Force Base, California**

February 1993

Prepared by

ENGINEERING-SCIENCE, INC.
DESIGN • RESEARCH • PLANNING
1301 MARINA VILLAGE PARKWAY, ALAMEDA, CA 94501 • 510/769-0100
OFFICES IN PRINCIPAL CITIES
30-20

TABLE OF CONTENTS

PART I
BIOVENTING PILOT TEST WORK PLAN FOR
INSTALLATION RESTORATION PROGRAM SITES 3 AND 18,
FIRE PROTECTION TRAINING AREA NO. 1 (SITE 3)
and BULK FUEL STORAGE AREA (SITE 18)

Beale AFB, California

| | <u>Page</u> |
|---|-------------|
| 1.0 INTRODUCTION..... | I-1 |
| 2.0 SITE DESCRIPTION..... | I-4 |
| 2.1 Fire Protection Training Area (Site 3)..... | I-4 |
| 2.1.1 Site Location and History..... | I-4 |
| 2.1.2 Site Geology..... | I-6 |
| 2.1.3 Site Contaminants..... | I-6 |
| 2.2 Bulk Fuel Storage Area (Site 18)..... | I-9 |
| 2.2.1 Site Location and History..... | I-9 |
| 2.2.2 Site Geology..... | I-12 |
| 2.2.3 Site Contaminants..... | I-14 |
| 3.0 SITE-SPECIFIC ACTIVITIES..... | I-18 |
| 3.1 Location and Construction of Vent Wells and Vapor Monitoring Points..... | I-18 |
| 3.1.1 Fire Protection Training Area No. 1 (Site 3)..... | I-18 |
| 3.1.2 Bulk Fuel Storage Area (Site 18)..... | I-21 |
| 3.2 Handling of Drill Cuttings..... | I-24 |
| 3.3 Soil and Gas Sampling..... | I-24 |
| 3.3.1 Soil Sampling..... | I-24 |
| 3.3.2 Soil Gas Sampling..... | I-25 |
| 3.4 Blower System..... | I-25 |
| 3.5 <i>In Situ</i> Respiration Tests..... | I-25 |
| 3.6 Air Permeability Tests..... | I-25 |
| 3.7 Installation of Extended Bioventing Pilot Test Systems..... | I-27 |
| 4.0 EXCEPTIONS TO PROTOCOL PROCEDURES..... | I-28 |

TABLE OF CONTENTS (continued)

5.0 BASE SUPPORT REQUIREMENTS..... I-29
 5.1 Test Preparation..... I-29
6.0 PROJECT SCHEDULE..... I-30
7.0 POINTS OF CONTACT..... I-31
8.0 REFERENCES..... I-32

LIST OF FIGURES

| <u>Figure</u> | <u>Page</u> |
|---|-------------|
| 1.1 Beale Air Force Base IRP Sites..... | I-2 |
| 2.1 Site Map, IRP Site 3, Fire Protection Training Area..... | I-5 |
| 2.2 Hydrogeologic Cross-Section A - A'..... | I-7 |
| 2.3 Geologic Cross-Section B - B'..... | I-8 |
| 2.4 Site Map, IRP Site 18, Bulk Fuel Storage Area..... | I-11 |
| 2.5 Hydrogeologic Cross-Section C - C'..... | I-13 |
| 2.6 Geologic Cross-Section D - D'..... | I-15 |
| 3.1 Site Map, IRP Site 3, FPTA No. 1..... | I-19 |
| 3.2 Venting Well Construction Diagram..... | I-20 |
| 3.3 Vapor Monitoring Point Construction Diagram..... | I-22 |
| 3.4 Site Map, IRP Site 18, Bulk Fuel Storage Area (Northern Portion)..... | I-23 |
| 3.5 Blower System Instrumentation Diagram for Air Injection..... | I-26 |

LIST OF TABLES

| <u>Table</u> | <u>Page</u> |
|--|-------------|
| 2.1 Contaminant Concentrations at FPTA No. 1, IRP Site 3..... | I-10 |
| 2.2 Contaminant Concentrations at AVGAS Unloading Area, IRP Site 18..... | I-16 |

PART I
BIOVENTING PILOT TEST WORK PLAN FOR
INSTALLATION RESTORATION PROGRAM SITES 3 AND 18
FIRE PROTECTION TRAINING AREA NO. 1 (Site 3)
and BULK FUEL STORAGE AREA (Site 18)

Beale AFB, California

1.0 INTRODUCTION

This Pilot Test Work Plan presents the scope of two *in situ* bioventing pilot tests for treatment of fuel contaminated soils at Installation Restoration Program (IRP) Sites 3 and 18 at Beale AFB, California: Fire Protection Training Area (Site 3); and, Bulk Fuel Storage Area (Site 18). The location of all 24 IRP sites at Beale AFB, including Sites 3 and 18, are shown on Figure 1.1. These pilot tests have three primary objectives: 1) to assess the potential for supplying oxygen throughout the contaminated soil depth, 2) to determine the rate at which indigenous microorganisms will degrade fuel when stimulated by oxygen rich soil gas, and 3) to evaluate the potential for sustaining these rates of biodegradation until fuel contamination is remediated below regulatory standards.

Each of the bioventing pilot tests at Beale AFB, California will be divided into two test periods: an initial pilot test to determine important design parameters such as air permeability, biodegradation rates, and potential air emissions (via soil-gas escaping from the subsurface to the atmosphere during injection); and an extended (one-year) pilot test which will determine the long-term feasibility of implementing this remedial technology to biodegrade hydrocarbons at these sites. If bioventing proves to be feasible at these sites, pilot test data could be used to design and implement bioventing remediation systems. An added benefit of the pilot testing at Sites 3 and 18 is that a significant amount of the fuel contamination should be biodegraded during the extended (one-year) pilot tests since the bioventing will take place within the most contaminated soils at each site.

Additional background information on the development and recent success of the bioventing technology is found in the attached document entitled "Test Plan and Technical Protocol for a Field Treatability Test for Bioventing". This protocol document will also serve as the primary reference for pilot test well designs and detailed procedures which will be used during both tests.

Successful bioventing pilot testing has been implemented at Beale AFB. An air permeability (AP) and *in situ* respiration (ISR) pilot test was performed by Engineering Science, Inc. (ES) at IRP Site 22-A20 between 15 and 23 October 1991 with good results. This heating oil underground storage tank (UST) site was initially remediated in September 1990 with the excavation and removal of the 600-gallon UST along with approximately 600 cubic yards of Total Petroleum Hydrocarbon (TPH) contaminated soil. The TPH-contaminated soil, mainly associated with the sidewalls adjacent to the

FIGURE 1.1

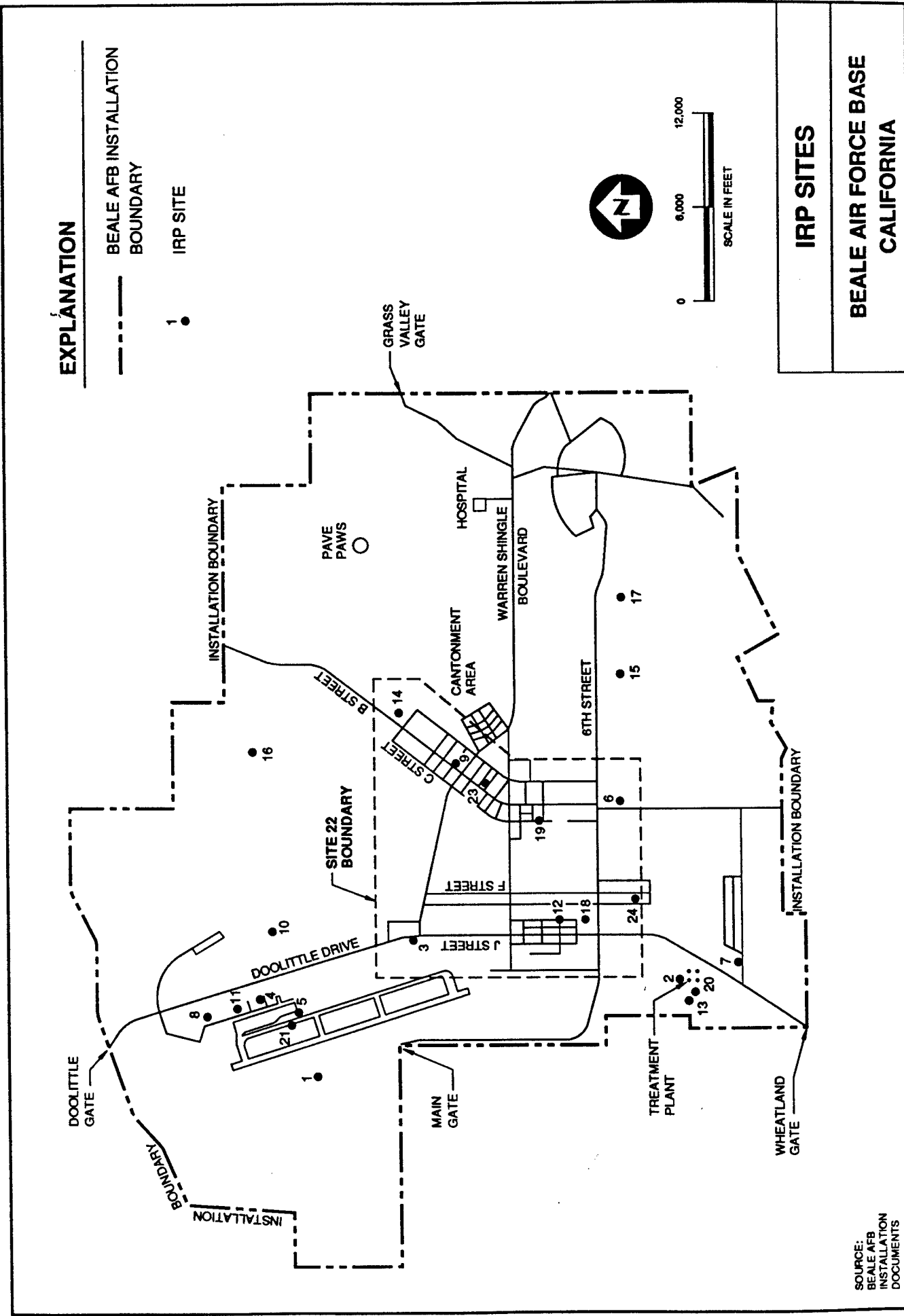

SOURCE:
BEALE AFB
INSTALLATION
DOCUMENTS

C232-01.R1 06/14/92

nearby building, remained in the ground after excavation operations. The pilot test showed that a vapor extraction rate of 65 standard cubic feet per minute (scfm) influenced soil gas movement within at least a 100-foot radius of the vent well (VW). In addition, the test indicated that existing soil bacteria are capable of consuming fuel residuals at a rate of approximately 750 - 900 mg of TPH per kilogram of soil per year when supplied with oxygen by moving fresh air through the soil. Based on these successful results, ES completed the installation of a full-scale bioventing treatment system on 9 July 1992 at the site consisting of a blower system connected to a vent well. The bioventing treatment system operates by moving fresh air through the subsurface soils via extraction at a flow rate averaging about 70 scfm. Weekly maintenance and quarterly monitoring are being performed.

Much of the background information on Sites 3 and 18 used in this Pilot Test Work Plan is derived from prior IRP studies and reports (AeroVironment 1987, CH2M Hill 1991). This information includes site maps, site histories, site geology/hydrogeology, and sampling/analytical data.

2.0 SITE DESCRIPTION

2.1 Fire Protection Training Area (Site 3)

2.1.1 Site Location and History

Site 3 is located in the western portion of Beale AFB at the juncture of Doolittle Drive and J Street, which is near the southern portion of the flightline (Figure 1.1). The site covers approximately 13 acres and is mostly flat. Figure 2.1 shows the detailed site plan. The main site features are: two Fire Protection Training Areas (FPTA No. 1 and FPTA No. 2) which are unlined fire pits; an overflow pond; and, two underground storage tanks (USTs). The bioventing pilot test at Site 3 will be conducted at FPTA No. 1 due to the soil contamination by fuel products resulting from fire training exercises, and the relatively higher contaminant concentrations found in soils at this area. Training exercises have been conducted at Site 3 in FPTA No. 1 and FPTA No. 2 since 1958.

At FPTA No. 1, the Base fire department conducted live fire-training exercises until the late 1960s. These exercises were performed in a former, 2-foot deep, unlined basin approximately 100 feet in diameter that was surrounded by a berm. This basin is no longer visibly evident. Combustible waste chemicals (reported to be waste oils, spent solvents, and aviation fuels) were accumulated in this former basin and burned weekly in the basin as part of the fire-training exercises. Other chemicals were accumulated in 55-gallon drums and burned in the same basin. No preapplication of water was implemented to retard percolation of waste chemicals into the soil. The use of FPTA No. 1 was discontinued in 1972.

FPTA No. 2 began operating in 1972 upon abandonment of FPTA No. 1. FPTA No. 2 consists of a shallow, unlined basin 150 feet in diameter surrounded by a 12-inch berm. A mock-up aircraft is inside the basin and was used for fire training exercises which involved simulated fires in and around the mock aircraft. The unlined basin was flooded with water which ponded due to the low permeability of near-surface clay soils. Jet fuel was introduced to the basin and floated on the ponded water in the basin. The fuel was then ignited for the fire training exercises. About 100 feet south of FPTA No. 2 is an unlined overflow pond designed to hold liquids drained from FPTA No. 2. Residual water and fuel were left in the overflow pond to evaporate. Following direction by the USEPA, fire training exercises ceased at FPTA No. 2 in 1988; FPTA No. 2 is being decommissioned. Fire training is currently conducted on a smaller scale at an 8-foot by 10-foot concrete-lined pit located approximately 400 yards west of FPTA No. 2.

There are two 25,000-gallon USTs, designated as the north tank and the south tank, which are located at Site 3 about 150 feet east of FPTA No. 2. The north tank contains jet fuel used for live fire training. The south tank has traditionally contained contaminated fuel, hydraulic fluid, and waste solvents. Underground fuel lines run from the USTs to the above-ground fuel nozzles in FPTA No. 2.

The only recorded spill incident at Site 3 occurred in May 1983. Fluid from the north tank was inadvertently pumped out of the tank and onto the ground. Appropriate regulatory agencies were notified of the spill, and subsequent soil testing indicated no required remedial action.

FIGURE 2.1

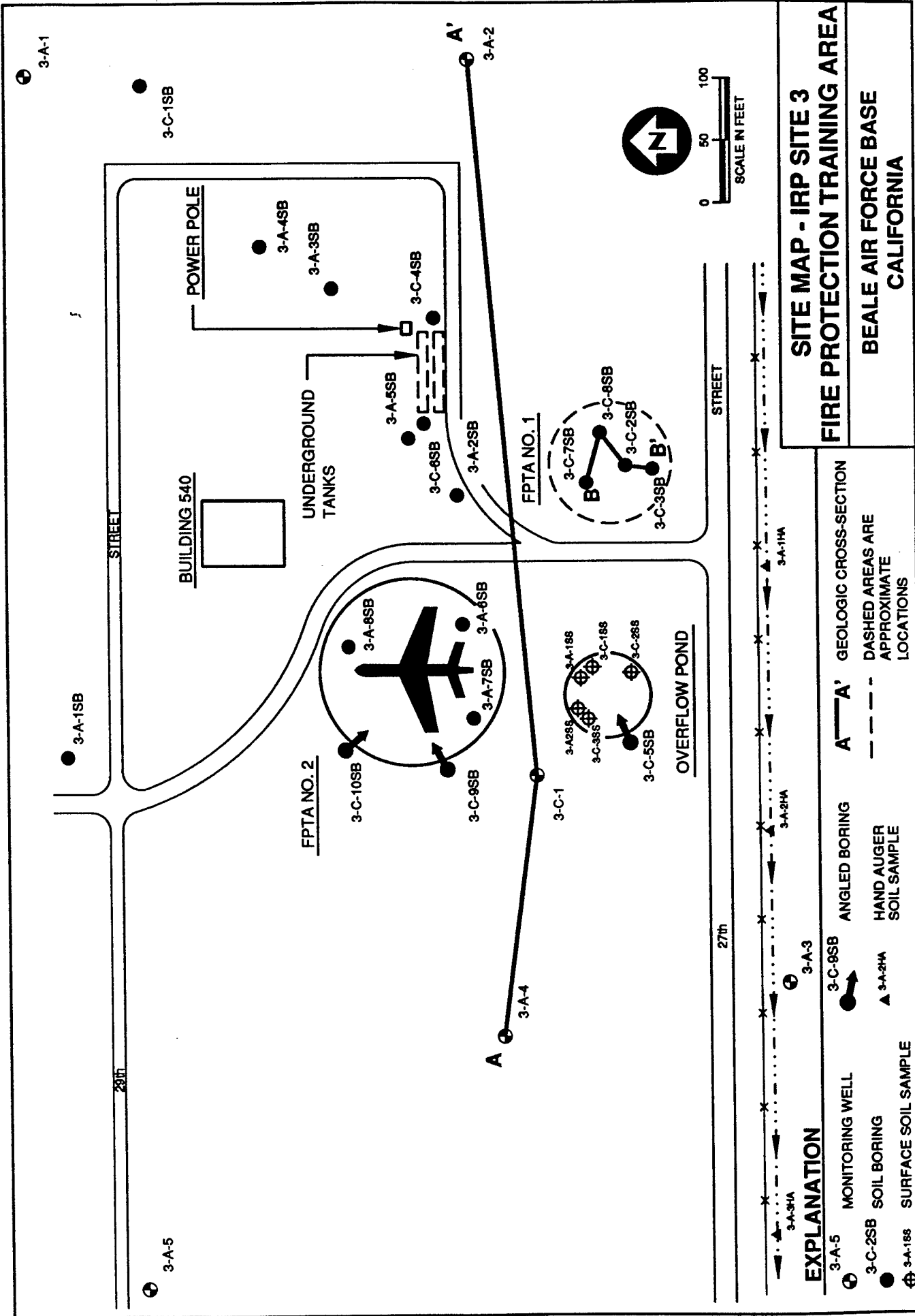

SITE MAP - IRP SITE 3
FIRE PROTECTION TRAINING AREA
BEALE AIR FORCE BASE
CALIFORNIA

| EXPLANATION | ANGLED BORING | A—A' | GEOLOGIC CROSS-SECTION |
|--------------------------------|---------------|------|--|
| 3-A-5 MONITORING WELL | 3-C-8SB | --- | DASHED AREAS ARE APPROXIMATE LOCATIONS |
| 3-C-2SB SOIL BORING | 3-A-2HA | --- | |
| 3-A-1SB SURFACE SOIL SAMPLE | 3-A-3 | --- | |

2.1.2 Site Geology

As part of previous IRP investigations (AeroVironment 1987, CH2M Hill 1991), numerous soil borings and groundwater monitoring wells were installed to collect surface soil samples, subsurface soil samples, and groundwater samples. Figure 2.1 shows the locations of the five surface soil sampling locations, three hand-augered soil sampling locations, 15 vertical soil borings, three angled soil borings, and six groundwater monitoring wells. Evaluation of the geology and contamination at Site 3 in this Pilot Test Work Plan is based on these borehole and well data.

Figure 2.2 is a hydrogeologic cross-section constructed from three groundwater monitoring well logs and shows the soil profile from the surface to a few feet below the water table at Site 3. The near-surface soils at Site 3 are predominantly fine-grained (silts and clays with some sandy silts) and become increasingly coarser-grained with depth to the water table (sands and sandy gravels with some sandy silts and thin clay layers). The base of each screened interval in the monitoring wells is terminated in a clay which appears to form the basal boundary of the coarse-grained deposits. The geologic deposits shown in Figure 2.2 constitute an alluvial sequence that has been mapped as the Laguna Formation (Page 1980). These are continental alluvial deposits of the Pleistocene and Pliocene Epochs composed of silts, sands, clays, and gravels. These deposits overlie older volcanic rocks which outcrop in the Sierra Nevada Foothills to the east.

Groundwater levels in Site 3 monitoring wells were measured in September 1991 at approximately 101 to 103 feet below ground surface (bgs). These water levels are found a few feet above the screened intervals (Figure 2.2). Groundwater flow direction at Site 3 is to the southwest with an average gradient across the site of approximately 0.015 ft/ft.

Figure 2.3 is a geologic cross-section constructed from four soil boring logs and shows the soil profile from surface to about 25 feet bgs at FTPA No. 1, the site of the proposed Site 3 bioventing test. Soils of the upper 10 to 15 feet are predominantly silts and clays with occasional indications of sand- and gravel-sized grains. These silts and clays grade to sands at a depth of approximately 12 to 14 feet bgs. There is some degree of lateral grain-size variation as well, with the sands grading to silts and silty clays. Beneath this sandy zone are mostly silts at about 20 to 25 feet bgs. The soil borings at FTPA No. 1 do not penetrate below about 82 feet in elevation NGVD (approximately 25 feet bgs). Therefore, there is no lithologic data at this specific area to indicate the grain size of the soils below this depth. However, the hydrogeologic cross-section shown in Figure 2.2 indicates that soils at the FTPA No. 1 below about 82 feet NGVD are probably composed predominantly of sands and gravels down to the water table. Therefore, the nature of the soils at the FTPA No. 1 appear to be well-suited to bioventing as a method to remediate the soil contamination at this site.

2.1.3 Site Contaminants

The primary contaminants documented in soils at Site 3 in previous IRP studies and reports (AeroVironment 1987, CH2M Hill 1991) are fuel residuals with minor amounts

FIGURE 2.2

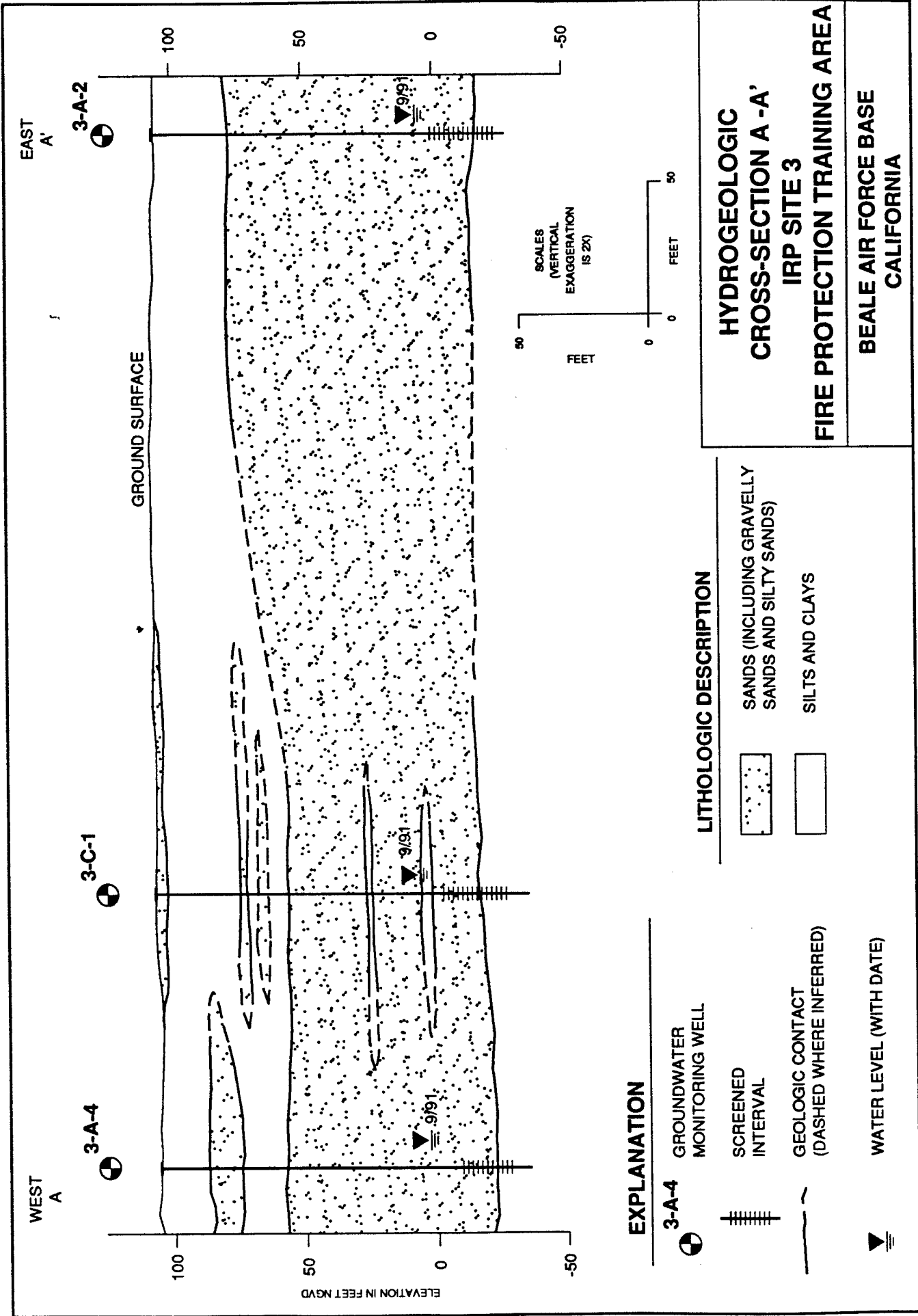
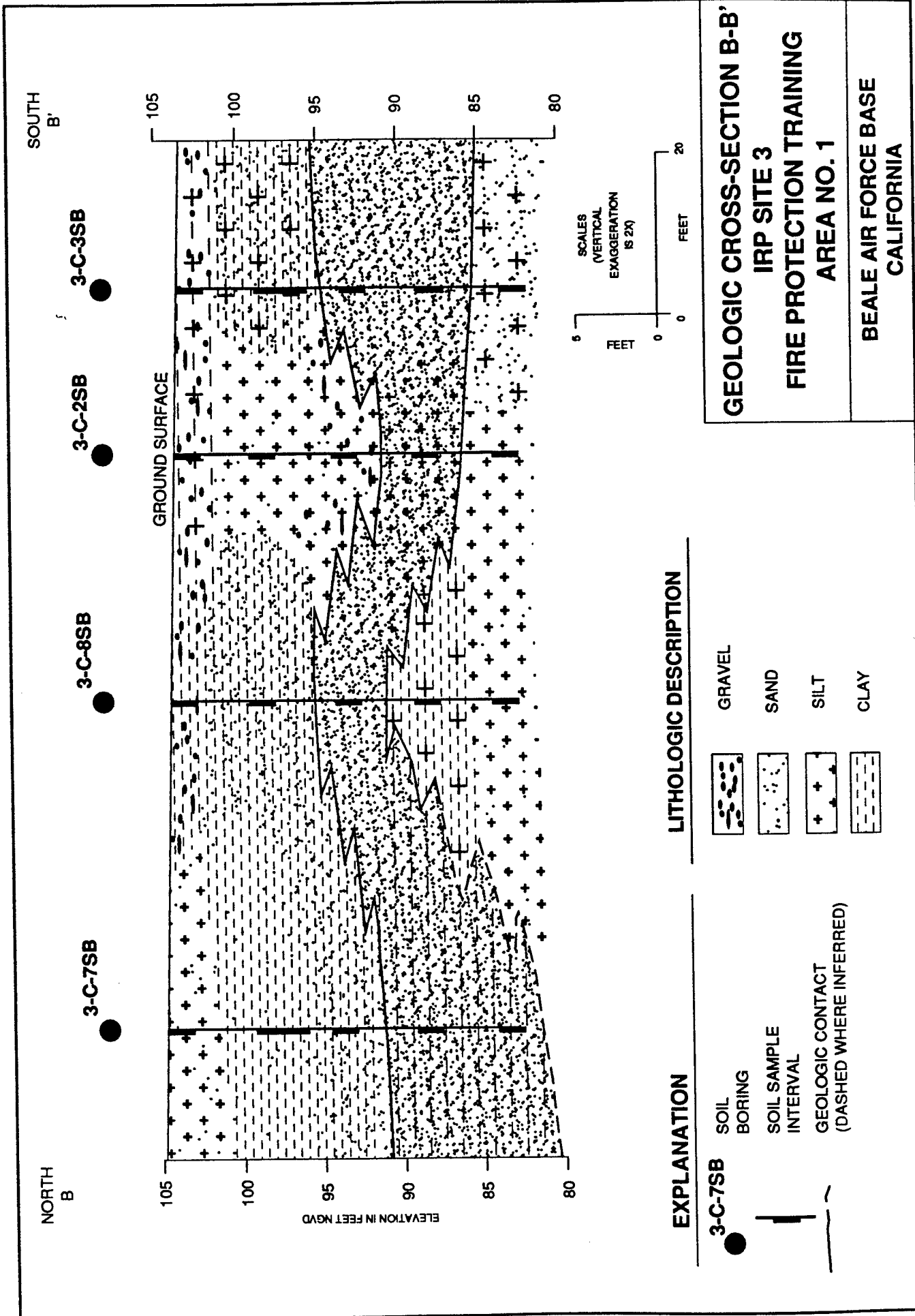

FIGURE 2.3



of solvents. The maximum concentrations for each analyte detected at Site 3 were from soil samples at the FPTA No. 1.

Table 2.1 presents analytical data for selected fuel components, other volatile organic compounds, and metals (mercury and lead) for each of the 22 FPTA No. 1 soil samples collected from the four soil borings. These soil samples were collected at depths ranging from 1 foot to 21 feet bgs. The highest concentrations of petroleum hydrocarbons detected were 23,000 mg/kg TPH-d (Soil Boring 3-C-2SB) and 5,100 mg/kg TPH-g (Soil Boring 3-C-3SB) at depths of 11 feet bgs and 8 feet bgs, respectively. Concentrations of BTEX components were relatively lower; the highest was 7.9 mg/kg total xylenes at 11 feet bgs (Soil Boring 3-C-7SB).

Significant concentrations of TPH-d and TPH-g were detected in the deepest soil samples collected (21 feet bgs). Maximum concentrations at 21 feet bgs were 1,300 mg/kg TPH-d (Soil Boring 3-C-7SB) and 1,800 mg/kg TPH-g (Soil Boring 3-C-3SB). Therefore, it is not known how deep residual fuel contamination exists in soils at FPTA No. 1. Comparison of contaminant concentrations with depth at other areas within Site 3 is not appropriate, since practices at FPTA No. 1 did not include a liner system or preapplication of water. Thus, the fuel products in the soil beneath FPTA No. 1 have probably migrated deeper than at FPTA No. 2. Contamination migrating downward under the influence of gravity should move predominantly vertically but may spread beyond the original surface area due to dispersion around soil particles and/or flow along low-permeability boundaries.

Historical results of groundwater sample analysis from Site 3 monitoring wells indicate that no measurable degradation of the groundwater has occurred at the site. This is probably due in part to the relative great thickness of the unsaturated zone at the site (approximately 100 feet) and the migration attenuation ability of the lower-permeable silts and clays near the ground surface.

2.2 Bulk Fuel Storage Area (Site 18)

2.2.1 Site Location and History

Site 18 is located in the southwestern portion of Beale AFB near the juncture of J Street and 6th Street (Figure 1.1). Figure 2.4 shows the detailed site plan. The main site features are the AVGAS Facility and the MOGAS Facility which are two areas of large, aboveground fuel storage tanks that are surrounded by dykes. The dykes consist of 3-inch thick concrete with synthetic liners that were constructed after the most recent IRP soil sampling by CH2M Hill in 1991. The bioventing pilot test at Site 18 will be conducted along the railroad tracks at the north end of the facility (designated as the AVGAS unloading area). This is the only area of the site with subsurface lithologic and contamination data near the AVGAS Facility, exclusive of the two groundwater monitoring wells. This is also the most feasible area within Site 18 to conduct the bioventing test for two reasons: the proximity of a power source; and, the severe logistical problems associated with dyked areas around the storage tanks.

The Bulk Fuel Storage Area has been in operation since 1958. Fuels are delivered to and from the aboveground tanks by train, truck, or pipeline. Fuels at the site have

TABLE 2.1

Contaminant Concentrations at
 FPTA No. 1
 Fire Protection Training Area (IRP Site 3)
 Beale AFB, California

Contaminants

| TPH-4 | TPH-g | Benzene | Toluene | Ethyl Benzene | Total Xylenes | TCE | PCE | DCE | Acetone | Methylan Chloride | Chloro Benzene | 4M2P | Butanone | NAP | 2M2AP | Phenol | Lead | Mercury |
|----------------------------|-------|---------|---------|---------------|---------------|-------|-------|-------|---------|-------------------|----------------|------|----------|-------|-------|--------|------|---------|
| Soil Boring 3-C-75B | | | | | | | | | | | | | | | | | | |
| | 17000 | ND | 0.73 | 0.42 | ND | ND | NR | NR | NR | ND | NR | NR | NR | 5.2 | ND | NR | 251 | 0.12 |
| Sample @ 1ft bgs | 790 | ND | 0.028 | ND | ND | ND | NR | NR | NR | 0.022 | NR | NR | NR | 0.31 | NR | NR | 61.5 | ND |
| Sample @ 6ft bgs | 85 | ND | 0.032 | ND | 0.046 | ND | NR | NR | NR | 0.028 | NR | NR | NR | ND | NR | NR | ND | ND |
| Sample @ 8ft bgs | 740 | ND | 0.67 | 1.9 | 7.9 | 7 | NR | NR | NR | NR | NR | NR | NR | 0.6 | ND | NR | ND | ND |
| Sample @ 11ft bgs | 16000 | ND | 0.77 | 0.69 | 2.7 | 2.1 | NR | NR | NR | ND | NR | NR | NR | 0.41 | ND | NR | ND | ND |
| Sample @ 16ft bgs | 1300 | ND | 0.2 | 0.063 | 0.1 | 0.14 | 0.008 | NR | 0.017 | ND | NR | NR | NR | NA | ND | NR | ND | NR |
| Sample @ 21ft bgs | | | | | | | | | | | | | | | | | | |
| Soil Boring 3-C-85B | | | | | | | | | | | | | | | | | | |
| | 1500 | NR | 0.14 | ND | ND | ND | ND | NR | 0.049 | 0.079 | NR | NR | NR | ND | ND | NR | 240 | ND |
| Sample @ 1ft bgs | 620 | NR | 0.85 | ND | ND | 0.71 | ND | NR | 2.7 | 5.4 | NR | NR | NR | NR | 0.13 | NR | ND | ND |
| Sample @ 6ft bgs | 5.7 | ND | 0.023 | ND | ND | 0.054 | ND | NR | 0.047 | 0.015 | NR | NR | NR | NR | 0.018 | NR | ND | ND |
| Sample @ 11ft bgs | ND | NR | 0.034 | ND | ND | ND | ND | NR | 0.04 | 0.062 | NR | NR | NR | NR | 0.012 | NR | ND | NR |
| Sample @ 16ft bgs | 94 | ND | 0.072 | ND | ND | ND | ND | NR | 0.042 | 0.053 | NR | NR | NR | NR | 0.014 | NR | ND | NR |
| Sample @ 21ft bgs | | | | | | | | | | | | | | | | | | |
| Soil Boring 3-C-25B | | | | | | | | | | | | | | | | | | |
| | 170 | ND | 0.074 | 0.022 | 0.14 | ND | NR | NR | 0.12 | 0.078 | NR | NR | NR | NR | NR | 2.1 | NR | 0.097 |
| Sample @ 1ft bgs | 490 | NR | 0.057 | ND | 0.051 | NR | NR | NR | 0.28 | 0.089 | NR | NR | NR | NR | NR | 2.2 | NR | ND |
| Sample @ 6ft bgs | 23000 | 1600 | 0.19 | ND | 0.39 | 1.2 | ND | 0.069 | ND | 0.81 | NR | NR | NR | ND | 6.8 | ND | ND | ND |
| Sample @ 11ft bgs | ND | ND | 0.008 | ND | ND | ND | ND | NR | 0.15 | 0.006 | NR | NR | NR | NR | ND | 1.4 | ND | ND |
| Sample @ 16ft bgs | ND | ND | 0.055 | ND | ND | ND | ND | NR | 0.006 | 0.042 | NR | NR | NR | NR | ND | 1.7 | ND | ND |
| Sample @ 21ft bgs | | | | | | | | | | | | | | | | | | |
| Soil Boring 3-C-35B | | | | | | | | | | | | | | | | | | |
| | 29 | ND | 0.017 | 0.76 | 0.044 | 0.52 | 0.003 | 0.021 | 0.058 | ND | NR | NR | NR | 0.008 | ND | ND | 534 | 0.58 |
| Sample @ 1ft bgs | 3500 | 4300 | ND | 1.3 | ND | ND | ND | NR | ND | ND | NR | NR | NR | ND | ND | 1.7 | ND | ND |
| Sample @ 6ft bgs | 2500 | 5100 | NR | 0.83 | ND | NR | NR | NR | 1.6 | ND | NR | NR | NR | 1 | NR | ND | NR | ND |
| Sample @ 8ft bgs | 54 | 770 | NR | ND | ND | NR | NR | NR | 1.7 | ND | NR | NR | NR | 0.89 | NR | ND | NR | 0.11 |
| Sample @ 11ft bgs | 3300 | 4900 | NR | 1.6 | ND | NR | NR | NR | 1.9 | 0.43 | NR | NR | NR | 0.97 | NR | ND | NR | 0.11 |
| Sample @ 16ft bgs | 240 | 1800 | NR | 0.027 | ND | NR | NR | NR | 0.12 | 0.028 | NR | NR | NR | 0.042 | NR | ND | NR | 0.11 |
| Sample @ 21ft bgs | | | | | | | | | | | | | | | | | | |

SOURCE: CH2M Hill (1991)

All concentrations listed are in milligrams per kilogram (mg/kg)

ND = Not Detected

NR = Not Reported

NT = Not Tested

File bafwep21.wqt

TPH-4 = Total Petroleum Hydrocarbons as Diesel
 TPH-g = Total Petroleum Hydrocarbons as Gasoline
 TCE = Trichloroethene
 PCE = Tetrachloroethene
 DCE = 1,2-Dichloroethane

Butanone = 2-Butanone
 NAP = Naphthalene
 2M2AP = 2-Methyl 2-Pentanone
 4M2P = 4-Methyl 2-Pentanone

included: jet fuels (AVGAS) including JP-4, JP-7, and JPTS; and, motor gasolines (MOGAS) including diesel fuel, unleaded gasoline, and No. 2 fuel oil. Jet fuels (JP-4 and JP-7) have been pumped via pipeline to a flightline-dispensing system for aircraft refueling. Trucks are also used to refuel aircraft. Railroad cars load and unload fuels at the AVGAS unloading area and at the MOGAS unloading facility. The large aboveground tanks that now contain fuel hold JP-4 and JPTS. Tanks that previously stored JP-7 are now empty. In addition, the JP-7 fueling system along the railroad tracks at the AVGAS unloading area are now inactive.

Fuel loading and unloading activities, spills, and leaks are the primary waste sources at Site 18. Fuel spills at unloading areas (including the AVGAS unloading area where the bioventing pilot test will be performed) and within the dyked areas have occurred. Losses of hydrocarbons from other sources (pipeline leaks, tank bottom leaks) are often difficult to detect and locate.

2.2.2 Site Geology

As part of previous IRP investigations (AeroVironment 1987, CH2M Hill 1991), numerous surface soil samples have been collected near the aboveground storage tanks (before construction of concrete dykes with liners) at both facilities. In addition, soil borings were drilled and sampled: three along the railroad tracks on the north side of the site (the AVGAS unloading area), and four at the MOGAS Facility. Also, two groundwater monitoring wells were installed at the site, one west of the AVGAS Facility and one west of the MOGAS Facility. Figure 2.4 shows the locations of the surface soil samples, soil borings, and groundwater monitoring wells. Evaluation of the geology and contamination at Site 18 in this Pilot Test Work Plan is based on the seven soil boring and three groundwater monitoring well data.

Figure 2.5 is a hydrogeologic cross-section constructed from the two groundwater monitoring well logs and shows the soil profile from the surface to a few feet below the water table at Site 18. The subsurface soil profile shown indicates a mixture of highly-variable alluvial sediments. Correlation of individual layers of sand or clay is difficult as there is evidence of lateral as well as vertical variability. It can be ascertained that permeable sands and gravels appear to be dominant below a depth of about 90 feet bgs (about 20 feet NGVD). Above this depth, silts and clays tend to be more prevalent. These geologic deposits shown in Figure 2.5, typical of near-surface alluvial deposits near the Sierra Nevada foothills, constitute an alluvial sequence that has been mapped as the Laguna Formation (Page 1980). These are continental alluvial deposits of the Pleistocene and Pliocene epochs composed of silts, sands, clays, and gravels. These deposits overlie older volcanic rocks which outcrop in the Sierra Nevada foothills to the east. The surface soils at Site 18 have been mapped as belonging to the San Joaquin Loam, a medium-textured soil formed on moderately old alluvial fans (SCS 1985).

Groundwater levels in Site 18 monitoring wells were approximately 105 feet bgs in September 1991. These water levels are found a few feet above the screened intervals (Figure 2.5). Groundwater flow direction at Site 18 is to the west with a gradient of approximately 0.005 ft/ft based on the two monitoring wells.

FIGURE 2.5

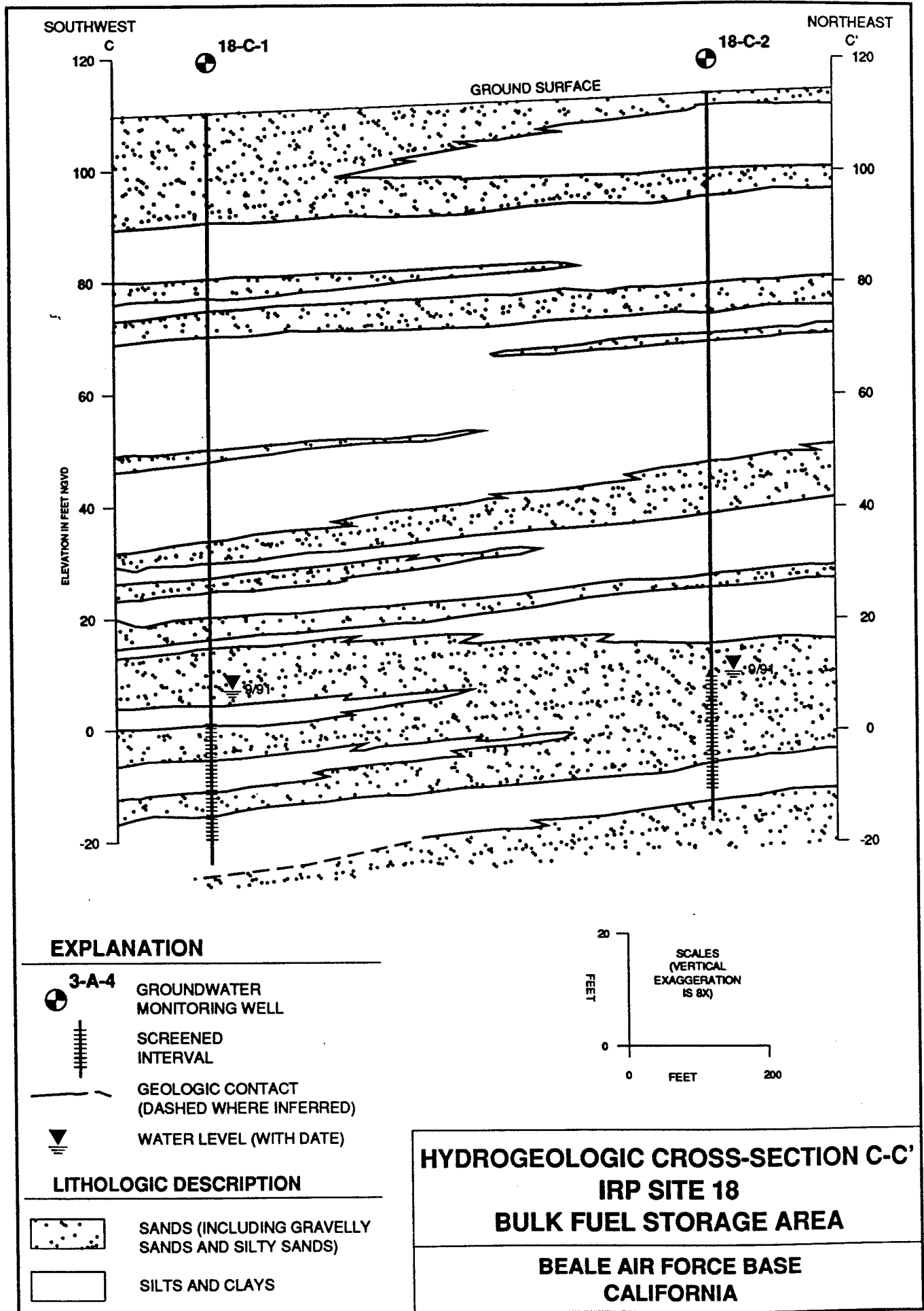

Figure 2.6 is a geologic cross-section constructed from three soil boring logs and shows the near-surface soil profile of the AVGAS unloading area, the site of the proposed Site 18 bioventing test. Soils immediately below the gravelly railroad ballast (1 to 2 feet thick) are a sandy lean clay of about 3 to 4 feet in thickness (down to 113 feet NGVD). Below this sandy clay, the three borings encountered a mixture of silts, sands, and clays. The geologic cross-section in Figure 2.6 shows the lateral and vertical variability of the soils between about 113 and 104 feet NGVD (about 4 to 13 feet bgs). There is no lithologic data to indicate soil type and grain size below 104 feet NGVD (13 feet bgs) at the AVGAS unloading area. The hydrogeologic cross-section shown in Figure 2.5 indicates soils below this depth down to the water table may be composed of predominantly silts and clays with some sand and gravel zones. However, extrapolation of borehole information at wells 18-C-1 and 18-C-2 to the subsurface at the AVGAS unloading facility is tenuous given the nature of these alluvial sediments. In any event, the nature of the soils at the AVGAS unloading area appear to be suitable to bioventing as a method to remediate the soil contamination at the site.

2.2.3 Site Contaminants

The primary contaminants documented in soils at Site 18 in previous IRP studies and reports (AeroVironment 1987, CH2M Hill 1991) are fuel residuals. These have been detected in surface soil samples within both facility tank farms and in samples from soil borings at both the MOGAS Facility and the AVGAS unloading area. Concentrations of contaminants in surface soil samples around the aboveground storage tanks were highly variable. The highest concentrations of petroleum hydrocarbons detected in these samples were 39,000 mg/kg TPH-d, and 7,800 mg/kg TPH-g. Concentrations of BTEX components in these samples were relatively lower; the highest was 49 mg/kg total xylenes. Other volatile organics and metals (including lead) were also detected in these surface soil samples.

Table 2.2 presents analytical data for selected fuel components, other volatile organic compounds, and metals (lead) for each of the 10 subsurface soil samples collected from the three soil borings at the AVGAS unloading area. These soil samples were collected at depths ranging from 3 feet to 13 feet bgs. The highest concentrations of petroleum hydrocarbons detected were 52,000 mg/kg TPH-d and 1,500 mg/kg TPH-g (both in Soil Boring 18-C-3SB) at a depth of 2 feet bgs. Concentrations of BTEX components were relatively lower; the highest was 280 mg/kg total xylenes at 6 feet bgs (Soil Boring 18-C-1SB).

Significant concentrations of TPH-d and TPH-g were detected in the deepest soil samples collected from these borings (11 to 13 feet bgs). Maximum concentrations in these deepest samples were 35,000 mg/kg TPH-d (Soil Boring 18-C-3SB) and 1,200 mg/kg TPH-g (Soil Boring 18-C-2SB), both at 11 feet bgs. Therefore, it is not known how deep residual fuel contamination exists in soils at the AVGAS unloading area. Comparison of contaminant concentrations with depth at other areas within Site 18 is not appropriate, since the closest subsurface soil contamination data is from the MOGAS Facility located 1,500 feet to the southwest.

FIGURE 2.6

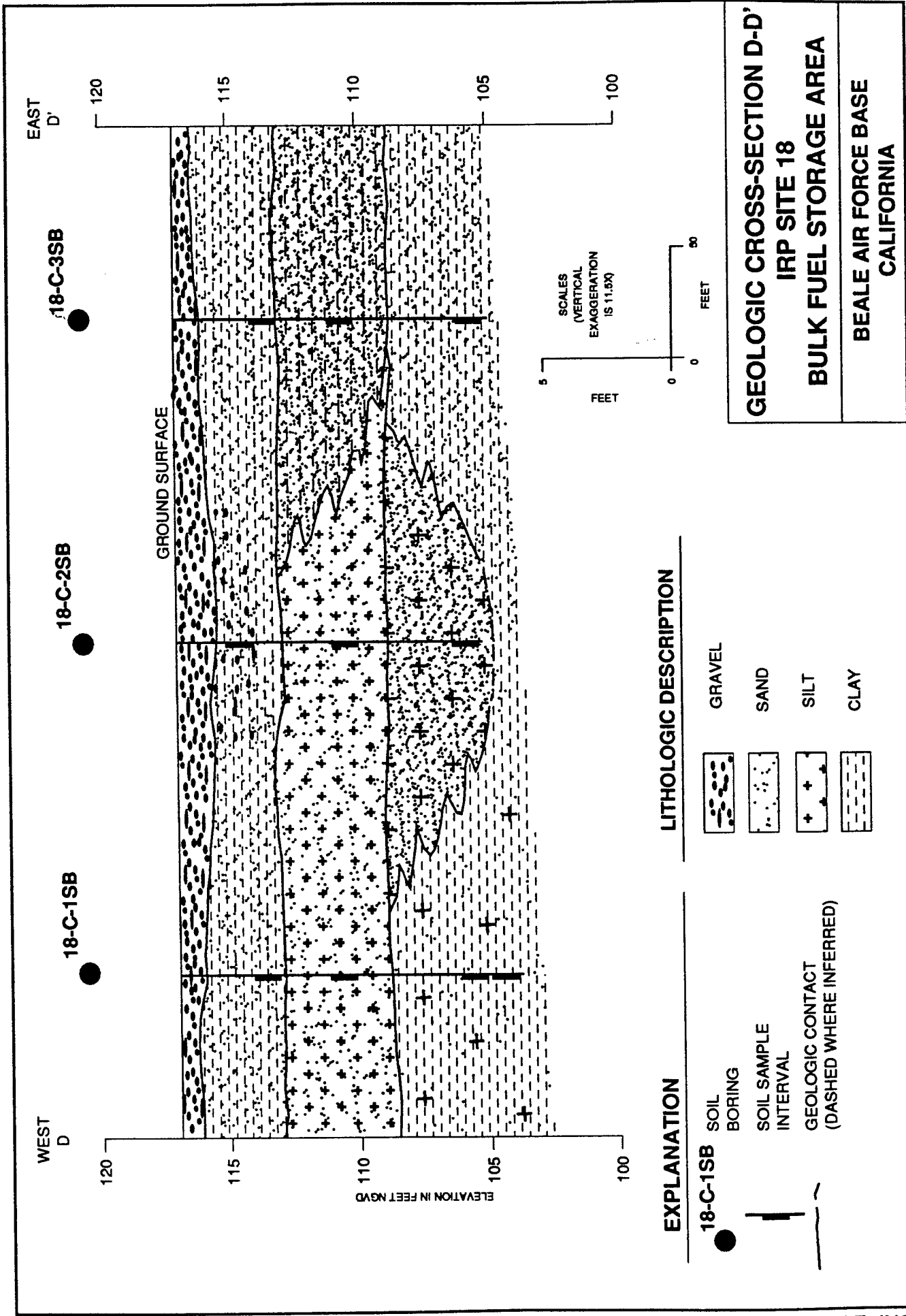

GEOLOGIC CROSS-SECTION D-D'
IRP SITE 18
BULK FUEL STORAGE AREA
BEALE AIR FORCE BASE
CALIFORNIA

TABLE 2.2

Contaminant Concentrations at
 AVGAS Unloading Area
 Bulk Fuel Storage Area (IRP Site 18)
 Beale AFB, California

Contaminants

| | TPH-d | TPH-g | Benzene | Toluene | Ethyl Benzene | Total Xylenes | TCE | PCE | DCE | Acetone | Methylen Chloride | Chloro-Benzene | 4M2P | Butanone | NAP | 2MINAP | Phenol | Lead | Mercury |
|-----------------------------|-------|-------|---------|---------|---------------|---------------|-----|-----|-----|---------|-------------------|----------------|------|----------|-----|--------|--------|------|---------|
| Soil Boring 18-C-1SB | | | | | | | | | | | | | | | | | | | |
| Sample @ 3ft bgs | 3300 | 530 | ND | 0.039 | 0.41 | 1.6 | ND | NR | ND | 0.15 | 0.082 | 0.091 | 0.16 | ND | NR | NR | NR | ND | NR |
| Sample @ 6ft bgs | 10000 | 630 | ND | ND | 67 | 280 | ND | NR | ND | 16 | ND | ND | 21 | ND | NR | NR | NR | ND | NR |
| Sample @ 11ft bgs | ND | ND | NR | 0.02 | ND | ND | NR | NR | NR | 0.023 | 0.036 | ND | ND | 0.008 | NR | NR | NR | ND | NR |
| Sample @ 13ft bgs | 1200 | 670 | ND | 0.052 | ND | ND | ND | NR | ND | 0.018 | 0.024 | NR | NR | ND | NR | NR | NR | 37.7 | NR |
| Soil Boring 18-C-2SB | | | | | | | | | | | | | | | | | | | |
| Sample @ 3ft bgs | 11000 | 1000 | ND | ND | ND | ND | ND | NR | ND | 0.19 | 0.058 | NR | NR | 0.093 | NR | NR | NR | ND | NR |
| Sample @ 6ft bgs | 450 | 25 | ND | 0.025 | ND | ND | ND | NR | ND | 0.077 | 0.057 | NR | NR | ND | NR | NR | NR | ND | NR |
| Sample @ 11ft bgs | 12000 | 1200 | 4.1 | ND | 17 | 17 | 26 | NR | 12 | 10 | 14 | NR | NR | ND | NR | NR | NR | ND | NR |
| Soil Boring 18-C-3SB | | | | | | | | | | | | | | | | | | | |
| Sample @ 2ft bgs | 52000 | 1500 | ND | ND | ND | ND | ND | NR | ND | 3.4 | 4.8 | NR | NR | 0.84 | NR | NR | NR | ND | NR |
| Sample @ 6ft bgs | 4700 | 850 | ND | 0.43 | ND | ND | 2.2 | NR | ND | 3.7 | 4.2 | NR | NR | 1.1 | NR | NR | NR | ND | NR |
| Sample @ 11ft bgs | 35000 | 490 | NR | 0.65 | NR | NR | NR | NR | NR | 2.1 | 2.8 | NR | NR | NR | NR | NR | NR | ND | NR |

SOURCE: CH2M Hill (1991)
 All concentrations listed are in milligrams per kilogram (mg/kg)

ND = Not Detected
 NR = Not Reported
 NT = Not Tested

File balbwp22.wq1

TPH-d = Total Petroleum Hydrocarbons as Diesel
 TPH-g = Total Petroleum Hydrocarbons as Gasoline
 TCE = Trichloroethene
 DCE = Tetrachloroethene
 DCE = 1,2-Dichloroethane

Butanone = 2-Butanone
 NAP = Naphthalene
 2MINAP = 2-Methylnaphthalene
 4M2P = 4-Methyl 2-Pentanone

Historical results of groundwater sample analysis (CH2M Hill 1991) from Site 18 monitoring wells indicate minimal impact to groundwater. Maximum detected concentrations are 12.0 µg/l toluene, 0.80 mg/l TPH-g, 0.053 mg/l manganese, 0.045 mg/l nickel, and 0.023 mg/l zinc. The detections of TPH-g are believed to be false positive results (CH2M Hill 1991); an explanation is not given in the CH2M Hill report. This apparent minimal impact to groundwater is probably due in part to the relative great thickness of the unsaturated zone at the site (over 100 feet).

3.0 SITE-SPECIFIC ACTIVITIES

The purpose of this section is to describe the work that will be performed by Engineering-Science, Inc. (ES) at IRP Sites 3 and 18. Activities that will be performed at each site include siting and construction of a central vent well (VW) and vapor monitoring points (VMPs), an initial pilot test (an *in situ* respiration test and an air permeability test), and an extended (one-year) pilot test. Soil and soil gas sampling procedures and the blower configuration that will be used to inject air (oxygen) into contaminated soils are also discussed in this section. No dewatering or groundwater treatment will take place during bioventing pilot testing. Pilot test activities will be confined to unsaturated soils remediation. Existing monitoring wells will not be used as primary air injection or extraction wells. Monitoring wells which have a portion of their screened interval above the water table may however be used as VMPs or used to measure the composition of background soil gas. However, recent water level measurements in all monitoring wells at Sites 3 and 18 indicate utilization of these wells will not be possible since none of the screened intervals are exposed to the unsaturated zone.

3.1 Location and Construction of Vent Wells and Vapor Monitoring Points

3.1.1 Fire Protection Training Area No. 1 (Site 3)

A general description of criteria for siting a central VW and VMPs are included in the attached protocol. Figure 3.1 indicates the proposed locations of the central VW and VMPs at Site 3. The final location of the VW and VMPs may vary slightly from the proposed location if significant fuel contamination is not observed in the boring for the central VW. Based on site investigation data, the central VW should be located in the center of the former bermed fire training pit of FPTA No. 1. This area is expected to have an average TPH-d concentration exceeding 5,000 mg/kg. Soils in this area are expected to be oxygen depleted (< 2 percent) and increased biological activity should be stimulated by oxygen-rich soil gas ventilation during full-scale operations.

The radius of venting influence around the central VW is estimated to be 50 to 60 feet based on the composition of the soils at Site 3. Three VMPs will be located within a 55-foot radius of the central VW. A fourth VMP will be located approximately 300 feet northeast of the central VW (near soil boring 3-A-4SB which is shown on Figure 2.1). This background VMP will be used to measure background levels of oxygen and carbon dioxide and to determine if natural carbon sources are contributing to oxygen uptake during the *in situ* respiration test. Additional details of the *in situ* respiration test are found in Section 5.7 of the attached protocol document.

Figure 3.2 is a central VW construction diagram for this site. The central VW will be constructed of 4-inch ID Schedule 40 PVC, with an interval of 0.04 slotted screen set from a depth of 10 feet bgs down to the base of contamination as determined by field organic vapor analysis (OVA) of soil samples. A 100 ppmv (parts per million by volume) OVA reading will be the criterion used in determining the depth selected as the base of contamination. Flush-threaded PVC casing and screen will be used with no organic solvents or glues. The filter pack will be clean, silica sand with a 6-9 grain size

FIGURE 3.1

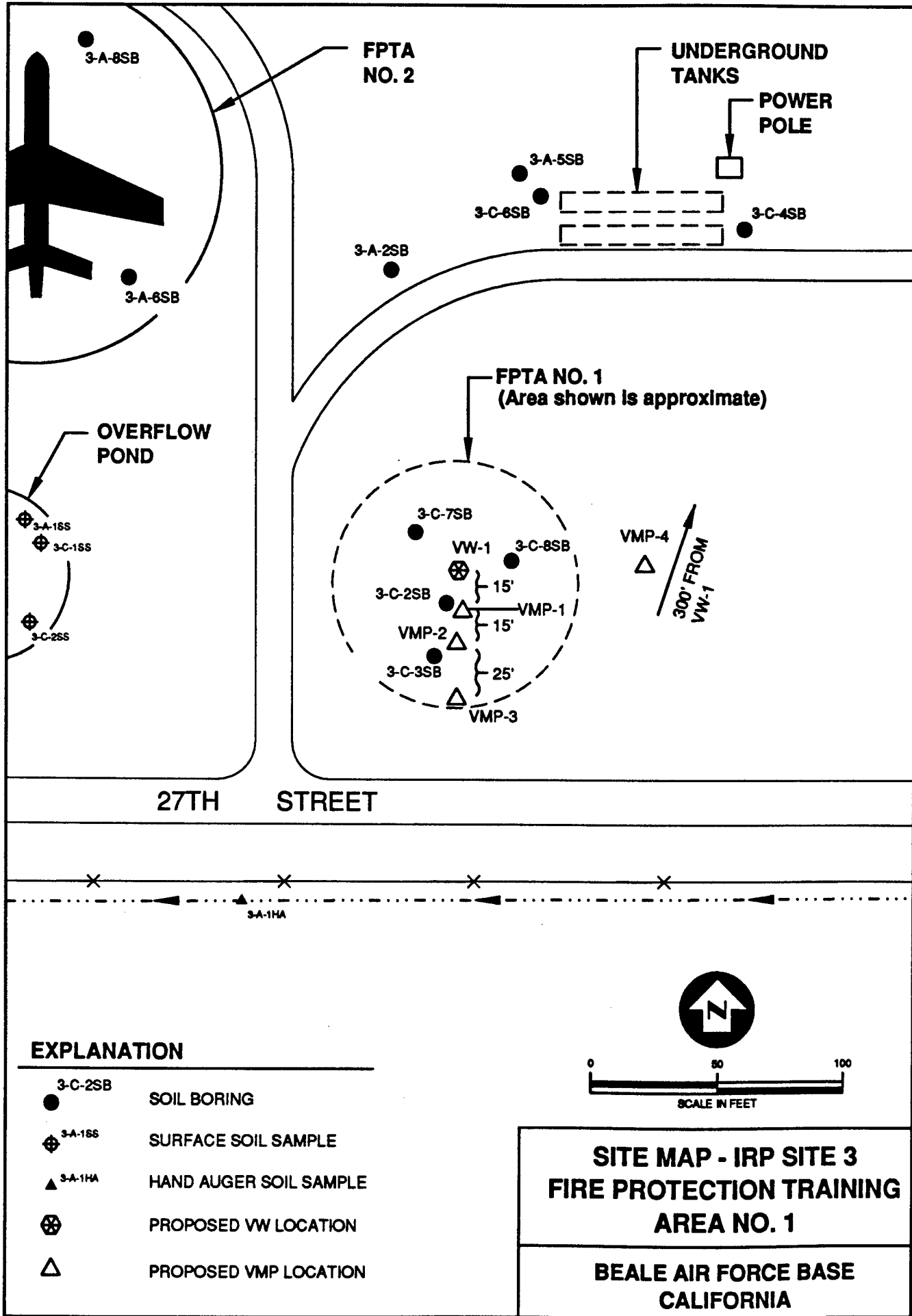

EXPLANATION

- 3-C-2SB SOIL BORING
- ⊕ 3-A-1SS SURFACE SOIL SAMPLE
- ▲ 3-A-1HA HAND AUGER SOIL SAMPLE
- ⊗ PROPOSED VW LOCATION
- △ PROPOSED VMP LOCATION

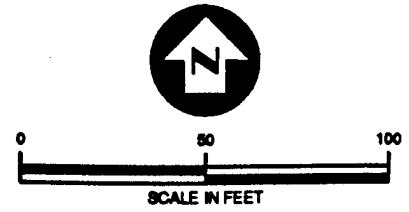

**SITE MAP - IRP SITE 3
FIRE PROTECTION TRAINING
AREA NO. 1**

**BEALE AIR FORCE BASE
CALIFORNIA**

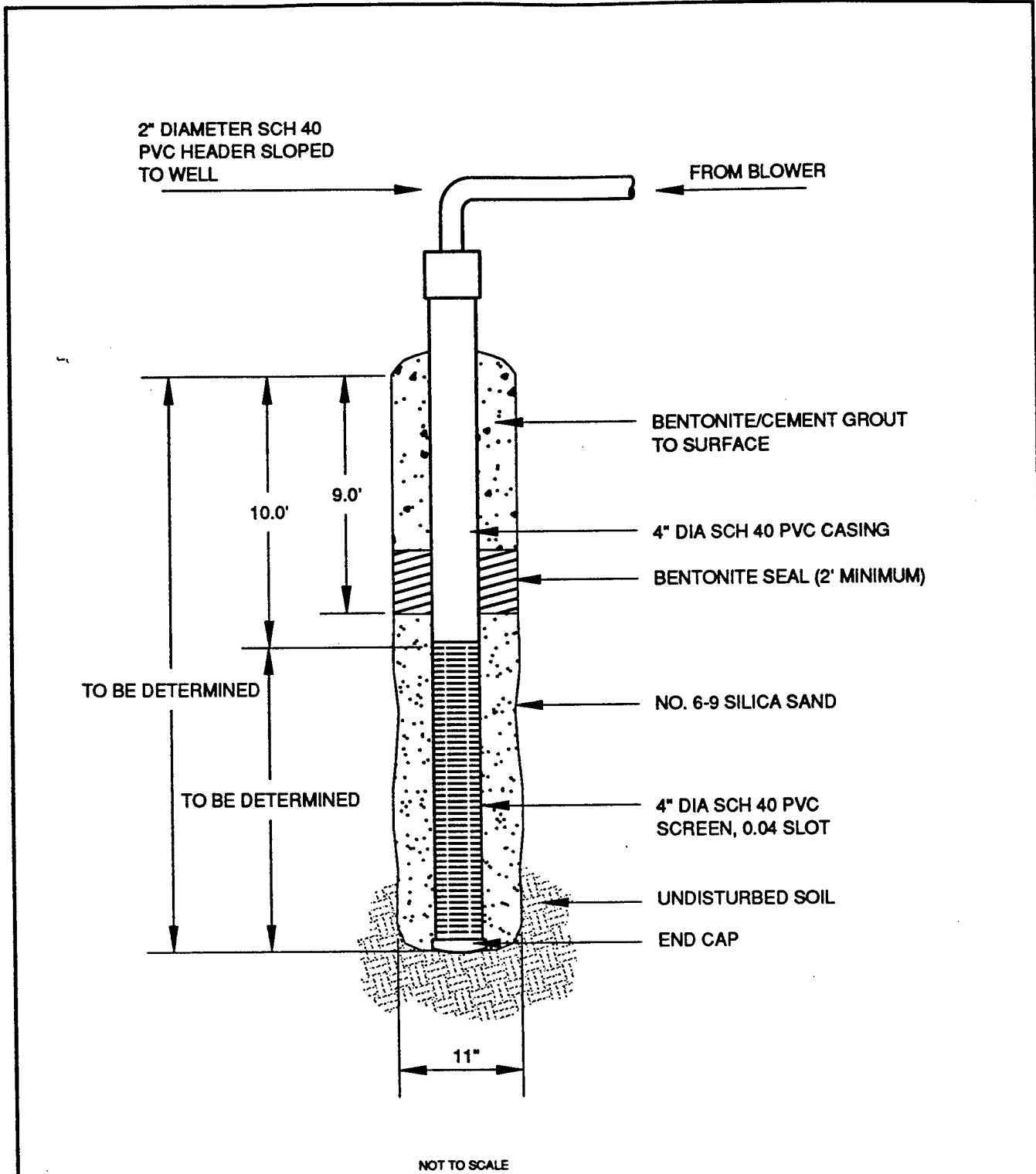

TO BE DETERMINED

TO BE DETERMINED

NOT TO SCALE

NOTE: DEPTH OF SCREENED INTERVAL WILL BE NEAR THE BASE OF CONTAMINATION AS DETERMINED IN THE FIELD.

**VENTING WELL
CONSTRUCTION DIAGRAM
IRP SITES 3 AND 18**

**BEALE AIR FORCE BASE
CALIFORNIA**

(or equivalent) and will be placed in the annular space of the screened interval. A 2-foot layer of bentonite will be placed directly over the filter pack. A complete seal is critical to prevent injected air from short-circuiting to the surface during the bioventing test. The remainder of the annular space will be filled with bentonite/cement grout.

A typical multi-depth VMP installation for this site is shown in Figure 3.3. Oxygen and carbon dioxide soil gas concentrations will be monitored via vapor monitoring screens placed at depth intervals of 5 feet, 10 feet, 25 feet, and near the base of contamination (if below 40 feet) as determined by the field OVA of soil samples at each location. If the base of contamination is determined to be below 40 feet, then the vapor monitoring screen depths may be altered to provide better vertical coverage for soil gas monitoring (e.g. 5 ft., 20 ft., 40 ft., 70 ft.). Multi-depth monitoring will assess whether the entire soil profile is receiving oxygen and will be used to measure fuel biodegradation rates at all monitored depths. The annular space between the vapor monitoring screen filter packs will be sealed with bentonite to isolate the monitoring intervals. As with the central VW, several inches of bentonite pellets will be used to seal the filter pack intervals. At the inner vapor monitoring point (VMP-1), thermocouples will also be installed at the same depths as the deepest and shallowest vapor monitoring screens to measure soil temperatures. Additional details on VW and VMP construction are found in Section 4 of the protocol document.

3.1.2 Bulk Fuel Storage Area (Site 18)

A general description of criteria for siting a central VW and VMPs are included in the attached protocol. Figure 3.4 indicates the proposed locations of the central VW and VMPs at Site 18. The final location of the VW and VMPs may vary slightly from the proposed location if significant fuel contamination is not observed in the boring for the central VW. Based on site investigation data, and proximity to a power source, the central VW should be located just east of Soil Boring 18-C-1SB. This area is expected to have an average TPH-d concentration exceeding 3,000 mg/kg. Soils in this area are expected to be oxygen depleted (< 2 percent) and increased biological activity should be stimulated by oxygen-rich soil gas ventilation during full-scale operations.

The radius of venting influence around the central VW is expected to be 50 to 60 feet based on the composition of the soils at Site 18. Three VMPs will be located within a 50-foot radius of the central VW. A fourth VMP to measure background levels of oxygen and carbon dioxide will not be installed at Site 18, as background readings from Site 3 will be sufficient. Additional details of the *in situ* respiration test are found in Section 5.7 of the attached protocol document.

Figure 3.2 is a central VW construction diagram for this site. The central VW will be constructed of 4-inch ID Schedule 40 PVC, with an interval of 0.04 slotted screen set from a depth of 10 feet bgs down to the base of contamination as determined by field organic vapor analysis (OVA) of soil samples. A 100 ppmv OVA reading will be the criterion used in determining the depth selected as the base of contamination. Flush-threaded PVC casing and screen will be used with no organic solvents or glues. The filter pack will be clean, silica sand with a 6-9 grain size and will be placed in the annular space of the screened interval. A 2-foot layer of bentonite will be placed directly over

FIGURE 3.3

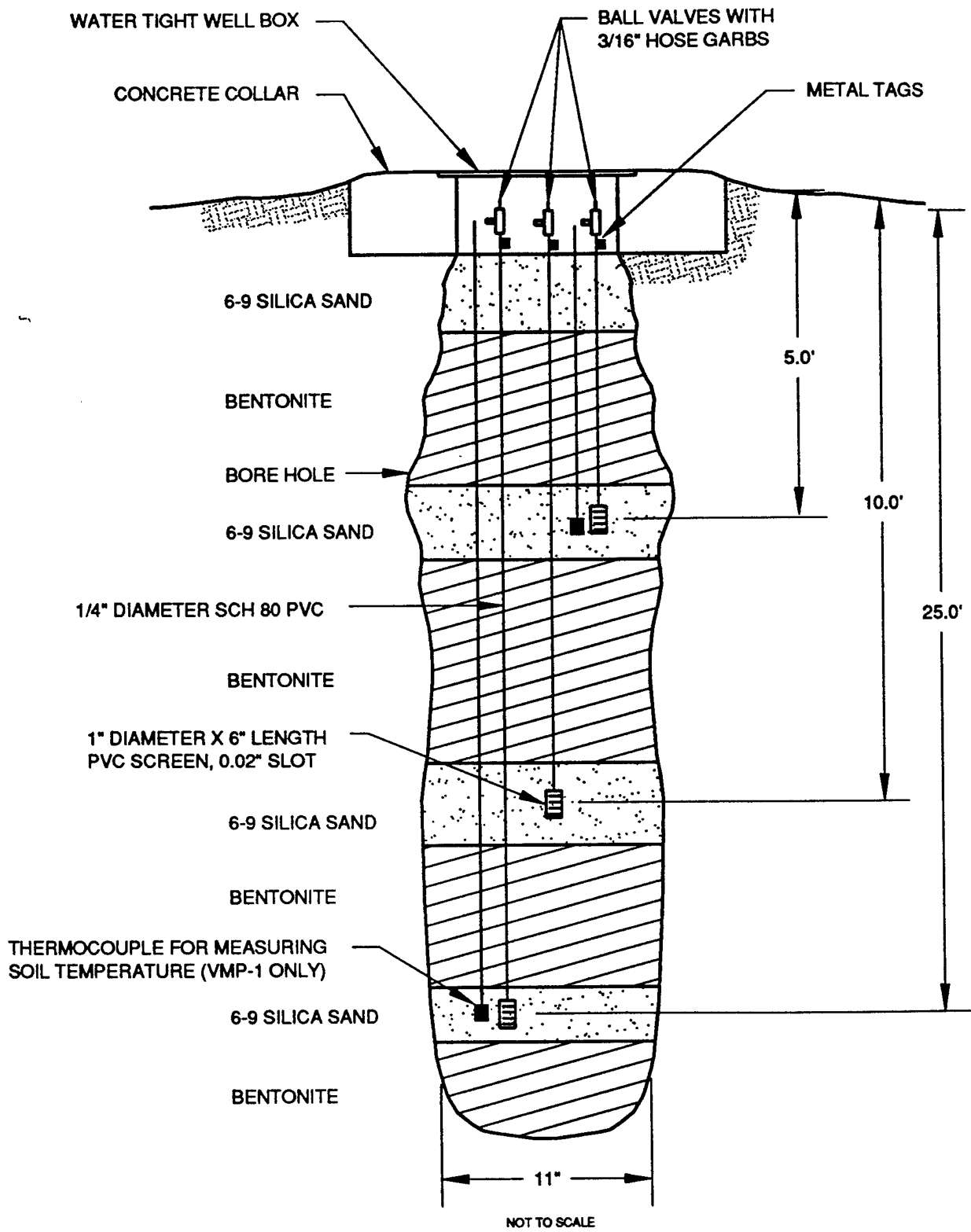

NOTE: AN ADDITIONAL VMP SCREEN WILL BE INSTALLED NEAR THE BASE OF CONTAMINATION (AS DETERMINED IN THE FIELD) IF THIS IS DETERMINED TO BE BELOW 40FT. BGS.

**VAPOR MONITORING POINT
CONSTRUCTION DIAGRAM
IRP SITES 3 AND 18**

**BEALE AIR FORCE BASE
CALIFORNIA**

FIGURE 3.4

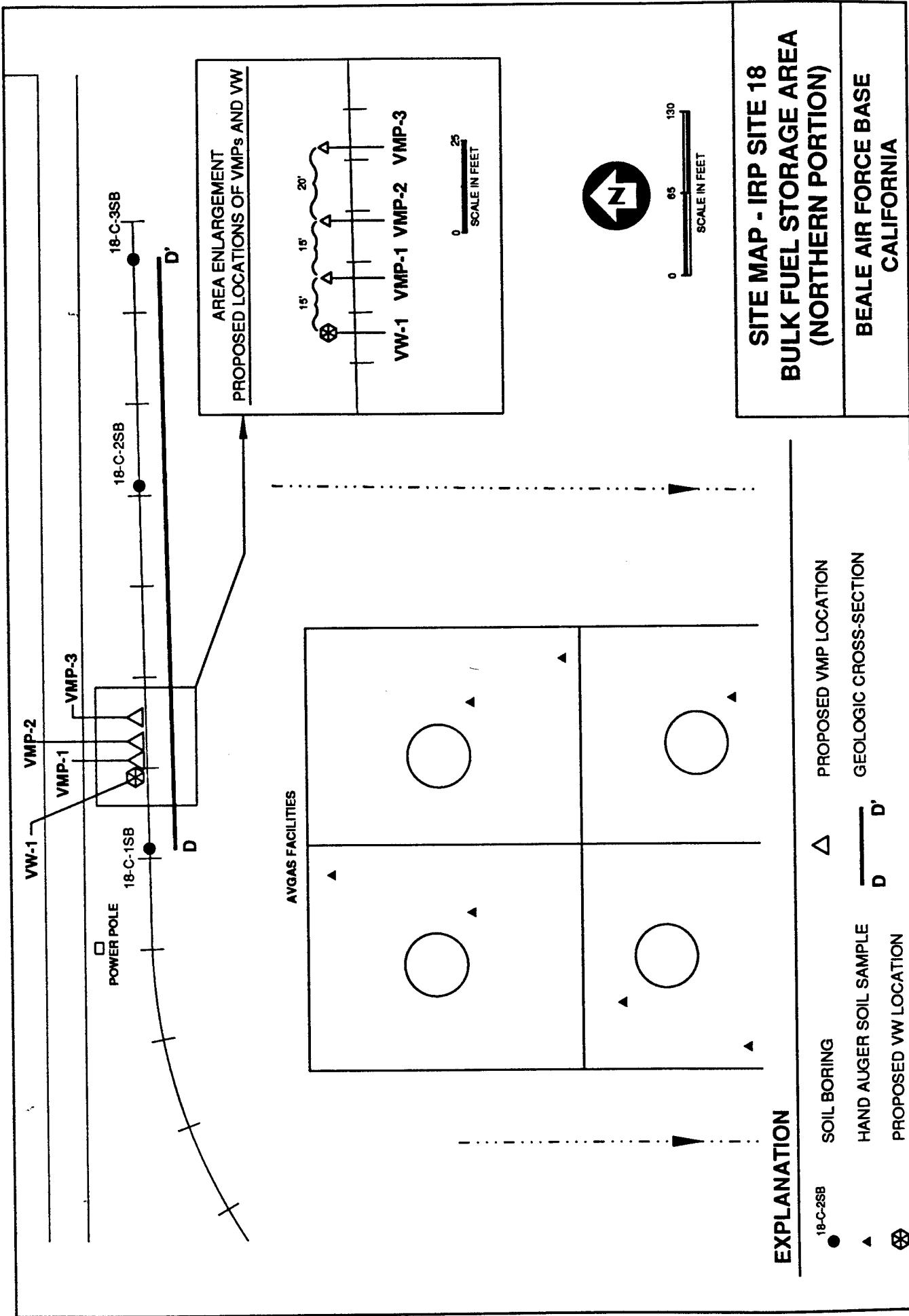

**SITE MAP - IRP SITE 18
BULK FUEL STORAGE AREA
(NORTHERN PORTION)**

**BEALE AIR FORCE BASE
CALIFORNIA**

the filter pack. A complete seal is critical to prevent injected air from short-circuiting to the surface during the bioventing test. The remainder of the annular space will be filled with bentonite/cement grout.

A typical multi-depth VMP installation for this site is shown in Figure 3.3. Oxygen and carbon dioxide soil gas concentrations will be monitored via vapor monitoring screens placed at depth intervals of 5 feet, 10 feet, 25 feet, and near the base of contamination (if below 40 feet) as determined by the field OVA of soil samples at each location. If the base of contamination is determined to be below 40 feet, then the vapor monitoring screen depths may be altered to provide better vertical coverage for soil gas monitoring. Multi-depth monitoring will assess whether the entire soil profile is receiving oxygen and will be used to measure fuel biodegradation rates at all monitored depths. The annular space between the vapor monitoring screen filter packs will be sealed with bentonite to isolate the monitoring intervals. As with the central VW, several inches of bentonite pellets will be used to seal the filter pack intervals. At the inner vapor monitoring point (VMP-1), thermocouples will also be installed at the same depths as the deepest and shallowest screens to measure soil temperatures. Additional details on VW and VMP construction are found in Section 4 of the protocol document.

3.2 Handling of Drill Cuttings

Drill cuttings from all VW and VMP borings will be handled in conformance with the base Draft Soil Management Plan (ES 1991). The cuttings will be screened with a photoionization detector (PID) by the on-site geologist or engineer to identify potential contamination. Soil cuttings with PID readings < 10 ppm will be spread out on the ground at the drill site. Soil cuttings with PID readings of > 10 ppm will be temporarily stockpiled on 10-mil Visqueen at the drill site. This soil will then be transported by the drilling contractor to the contaminated soil holding area located south of 9th Street between K and L Streets on the Base.

3.3 Soil and Gas Sampling

3.3.1 Soil Sampling

Three soil samples will be collected from each of the pilot test areas during the installation of the VW and VMPs. One sample will be collected from the most contaminated interval of the central VW boring, and one sample will be collected from the most contaminated interval in each of the borings for the two inner VMPs at each site (VMP-1 and VMP-2). Soil samples will be analyzed for total recoverable petroleum hydrocarbons (TRPH), benzene, toluene, ethylbenzene, and xylenes (BTEX), soil moisture, pH, particle sizing, alkalinity, total iron, and nutrients.

Samples collected for BTEX and TRPH analysis will be collected using a split-spoon sampler containing brass tube liners. Soil samples collected in the brass tubes will be immediately trimmed and the ends sealed with Teflon fabric held in place by plastic caps. Soil samples collected for physical parameter analysis will be placed into appropriate sample containers. Soil samples will be labeled following the nomenclature specified in the protocol document (Section 5), wrapped in plastic, and placed in an ice chest for shipment. A chain of custody form will be filled out and the ice chest shipped to the

Engineering-Science (ES) laboratory in Berkeley, California, for analysis. This laboratory has been audited by the U.S. Air Force and meets all quality assurance/quality control and certification requirements for the State of California.

3.3.2 Soil Gas Sampling

A total hydrocarbon vapor analyzer (THVA) (see protocol document, Section 4.5.2) will be used during drilling to screen split spoon samples for determination of the most contaminated intervals. During the pilot tests, initial and final soil gas samples will be collected in Summa[®] canisters from the central VW (VW-1) and the VMPs closest to and furthest from the central VW (VMP-1 and VMP-3). These soil gas samples will be used to predict potential air emissions, and determine the reduction in BTEX and total volatile hydrocarbons (TVH).

Soil gas samples will be placed in an ice chest and packed with foam pellets to prevent excessive movement during shipment. Samples will not be sent on ice in order to prevent condensation of hydrocarbons. A chain of custody form will be filled out and the ice chest shipped to the Air Toxics Laboratory in Rancho Cordova, CA for analysis.

3.4 Blower System

A 3.0 horsepower positive displacement blower capable of injecting 40 standard cubic feet per minute (scfm) at 7 psi will be used to conduct the initial air permeability tests at each site. Figure 3.5 is a schematic of a typical air injection system used for pilot testing. The maximum power requirement anticipated for these pilot tests is a 230 volt, single-phase, 30 amp service. Additional details on power supply requirements are described in Section 5.0, Base Support Requirements.

3.5 *In Situ* Respiration Tests

The objective of the *in situ* respiration tests is to determine the rate at which soil bacteria degrade petroleum hydrocarbons. Respiration tests will be performed at every vapor monitoring screen (point) where bacterial degradation of hydrocarbons is noted. These points of hydrocarbon degradation are characterized by low oxygen levels and elevated carbon dioxide concentrations in the soil gas. Air will be injected at each point containing low levels of oxygen (below 2 percent, approximately) for a 20-hour period to oxygenate local contaminated soils. At the end of the 20-hour air injection period, the air supply will be cut off and oxygen and carbon dioxide levels will be monitored for the following 48 to 72 hours. The decline in oxygen and increase in carbon dioxide concentrations over time will be used to estimate rates of bacterial degradation of fuel residuals. Helium will also be injected at one or two points to estimate oxygen diffusion rates in site soils.

3.6 Air Permeability Tests

The objective of the air permeability tests is to determine the extent of the subsurface that can be oxygenated using one air injection unit at a single VW to introduce clean soil gas. Air will be injected into the 4-inch diameter central VW (VW-1) using the blower unit, and pressure response will be measured at each VMP with differential pressure gauges to determine the region influenced by the unit. Oxygen will also be monitored in

FIGURE 3.5

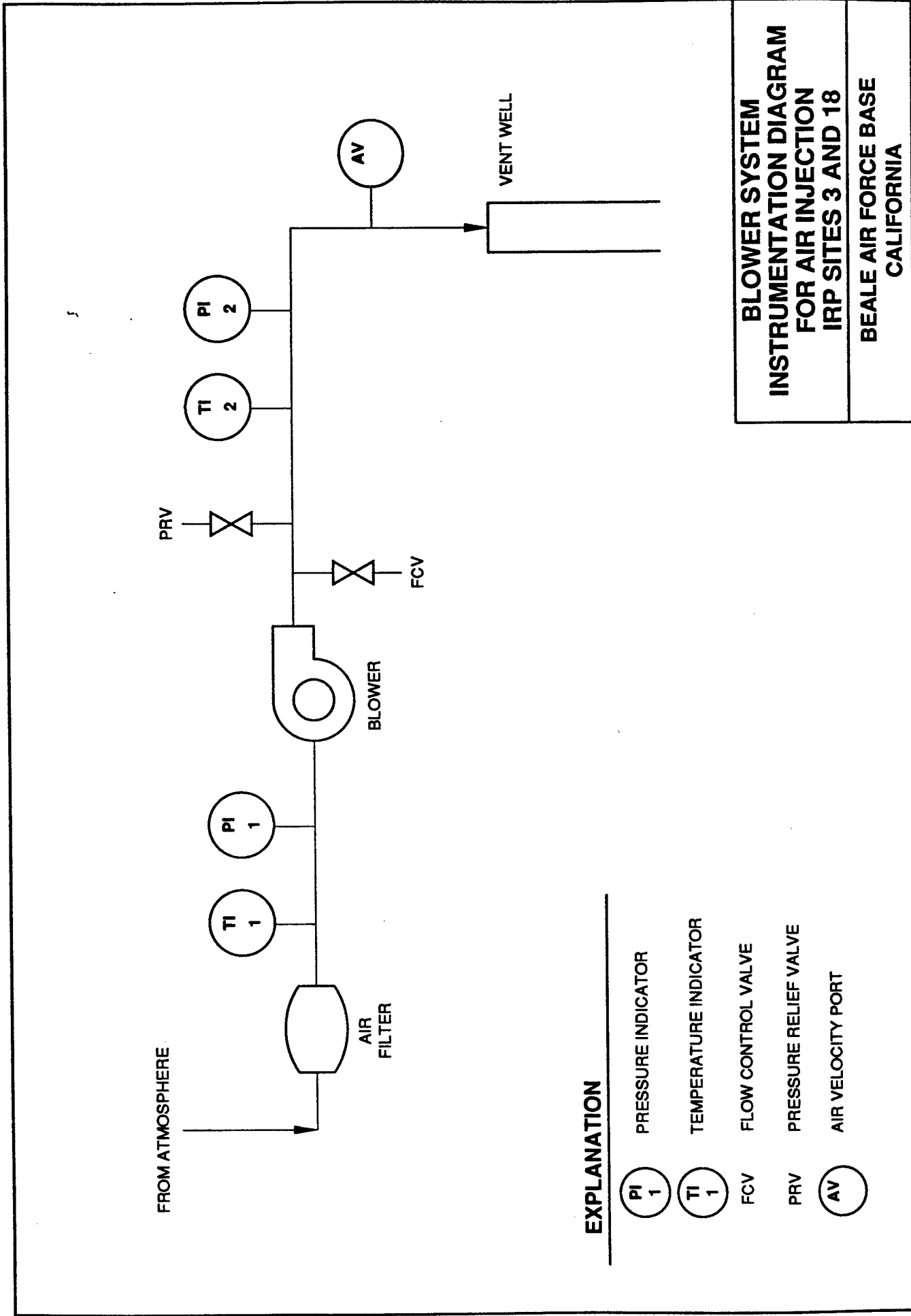

**BLOWER SYSTEM
INSTRUMENTATION DIAGRAM
FOR AIR INJECTION
IRP SITES 3 AND 18
BEALE AIR FORCE BASE
CALIFORNIA**

EXPLANATION

- PI 1 PRESSURE INDICATOR
- TI 1 TEMPERATURE INDICATOR
- FCV FLOW CONTROL VALVE
- PRV PRESSURE RELIEF VALVE
- AV AIR VELOCITY PORT

the VMPs to ascertain that oxygen levels in the soil increase as the result of air injection. One air permeability test lasting approximately 8 hours will be performed at each site.

3.7 Installation of Extended Bioventing Pilot Test Systems

An extended (one-year) bioventing pilot test system will be installed at Sites 3 and 18. A California-certified electrician will be brought on base to assist in wiring the blowers to line power. Each blower will be housed in a small, prefabricated shed ("dog house") to provide protection from the weather and to minimize noise.

Each system will be in operation for one year, and ES personnel will monitor it biannually, scheduled for July 1993 and January 1994. Biannual monitoring will consist of *in situ* respiration tests to monitor the long-term performance of these bioventing systems. Weekly system checks will be performed by Beale AFB personnel using the Operation and Maintenance (O&M) manual provided by ES. If required, major maintenance of the blower unit will be performed by ES-Alameda personnel. Detailed blower system information and a maintenance schedule will be included in the O&M manual provided to the base.

4.0 EXCEPTIONS TO PROTOCOL PROCEDURES

The procedures that will be used to measure the air permeability of the soil and *in situ* respiration rates are described in Sections 4 and 5 of the attached protocol document. No exceptions to the protocol are anticipated.

5.0 BASE SUPPORT REQUIREMENTS

5.1 Test Preparation

The following base support is needed prior to the arrival of a driller and the ES test team:

- Confirmation of regulatory approval for the pilot tests.
- Obtaining a base digging permit.
- Installation of new power lines to new power poles at each site. The poles should include a 230V/single phase/30 amp breaker box with one 230V receptacle and two 110V receptacles.
- Provide any paperwork required to obtain gate passes and security badges for approximately three ES employees and two drillers. Vehicle passes will be needed for two trucks and a drill rig.
- Provide a designated staging area for soil cuttings.

During the initial three week pilot tests at each site, the following base support is needed:

- Twelve square feet of desk space and a telephone in a building located as near to the site as practical.
- The use of a fax machine for transmitting 15 to 20 pages of test results.
- A decontamination pad where the driller can clean augers between borings.

During the one year extended pilot tests:

- Check the blower system once a week to ensure that it is operating and to record the air injection pressure and temperature. ES will provide a brief training session on this procedure.
- If the blower or motor stops working, notify Mr. Frederick Stanin or Mr. Richard Makdisi, ES-Alameda, (510) 769-0100, or Mr. Doug Downey or Ms. Gail Saxton, ES-Denver, (303) 831-8100, or Mr. Sam Taffinder of AFCEE, (210) 536-4366.
- Arrange site access for an ES technician to conduct *in situ* respiration tests at approximately six months and at one year after the initial pilot tests.

6.0 PROJECT SCHEDULE

The following schedule is contingent upon timely approval of this pilot test work plan.

| <u>Event</u> | <u>Date</u> |
|--|-------------------|
| Pilot Test Work Plan to AFCEE/Beale AFB | 15 September 1992 |
| Approval to Proceed | 25 September 1992 |
| Begin VW/VMP Installation | 19 October 1992 |
| Begin Initial Pilot Test | 26 October 1992 |
| Complete Initial Pilot Test | 13 November 1992 |
| Interim Results Report | February 1993 |
| Respiration Test | July 1993 |
| Final Respiration Test and Soil Sampling | January 1994 |

7.0 POINTS OF CONTACT

Ms. Sheri Rolfsness
9 CES/DEV
6451 B Street
Beale AFB, CA 95903-1708
(916) 634-2642
Fax (916) 634-2653

Major Ross Miller/Mr. Sam Taffinder
AFCEE/EST
2405 D-Drive, Suite 3
Brooks AFB, TX 78235-5103
(210) 536-4329 (Major Miller)
(210) 536-4366 (Mr. Taffinder)
Fax: (210) 536-4330

Mr. Doug Downey
Engineering-Science, Inc.
1700 Broadway, Suite 900
Denver, CO 80290
(303) 831-8100
Fax (303) 831-8208

Mr. Frederick Stanin
Mr. Richard Makdisi
Engineering-Science, Inc.
1301 Marina Village Parkway, Suite 200
Alameda, CA 94501
(510) 769-0100
Fax (510) 769-9244

8.0 REFERENCES

- AeroVironment 1987, Installation Restoration Program Phase II, Stage 1 Confirmation/Quantification Study Final Report. May
- CH2M Hill 1991, Installation Restoration Program Stage 2-1 Remedial Investigation, Final Report for Beale AFB, California. March
- Engineering-Science, Inc. 1991, Installation Restoration Program Stage 2, Soil Management Plan, Beale AFB, California, Second Draft. August
- Page 1980, Groundwater Conditions at Beale AFB and Vicinity, California, USGS Open File Report 80-204.

DRAFT

PART II

DRAFT

Interim Bioventing Pilot Test Results Report for

INSTALLATION RESTORATION PROGRAM SITES 3 AND 18

**Fire Protection Training Area No. 1 (Site 3)
Bulk Fuel Storage Area (Site 18)
BEALE AIR FORCE BASE, CALIFORNIA**

Prepared for

**Air Force Center for Environmental Excellence
Brooks AFB, Texas
and
Beale Air Force Base, California**

February 1993

Prepared by

ENGINEERING-SCIENCE, INC.
DESIGN • RESEARCH • PLANNING
1301 MARINA VILLAGE PARKWAY, ALAMEDA, CA 94501 • 510/769-0100
OFFICES IN PRINCIPAL CITIES
30-20

TABLE OF CONTENTS

PART II DRAFT INTERIM BIOVENTING PILOT TEST RESULTS REPORT FOR INSTALLATION RESTORATION PROGRAM SITES 3 AND 18, FIRE PROTECTION TRAINING AREA NO. 1 (SITE 3) and BULK FUEL STORAGE AREA (SITE 18)

Beale AFB, California

| | <u>Page</u> |
|---|-------------|
| 1.0 PILOT TEST DESIGN AND CONSTRUCTION..... | II-1 |
| 1.1 Fire Protection Training Area No. 1 (Site 3)..... | II-1 |
| 1.1.1 Air Injection Vent Well | II-5 |
| 1.1.2 Vapor Monitoring Points..... | II-5 |
| 1.1.3 Blower Units..... | II-5 |
| 1.1.4 Exceptions to Test Protocol Document Procedures | II-9 |
| 1.2 Bulk Fuel Storage Area (Site 18)..... | II-9 |
| 1.2.1 Air Injection Vent Well | II-15 |
| 1.2.2 Vapor Monitoring Points..... | II-15 |
| 1.2.3 Blower Units..... | II-19 |
| 1.2.4 Exceptions to Test Protocol Document Procedures | II-19 |
| 2.0 PILOT TEST SOIL AND SOIL-GAS SAMPLING RESULTS | II-21 |
| 2.1 Fire Protection Training Area No. 1 (Site 3)..... | II-21 |
| 2.1.1 Soil Sample Field Analysis | II-21 |
| 2.1.2 Soil Sample Laboratory Analysis..... | II-21 |
| 2.1.3 Soil-Gas Sample Laboratory Analysis | II-21 |
| 2.1.4 Field QA/QC Results..... | II-23 |
| 2.1.5 Exceptions to Test Protocol Document Procedures | II-23 |
| 2.2 Bulk Fuel Storage Area (Site 18)..... | II-23 |
| 2.2.1 Soil Sample Field Analysis | II-23 |
| 2.2.2 Soil Sample Laboratory Analysis..... | II-24 |
| 2.2.3 Soil-Gas Sample Laboratory Analysis | II-24 |
| 2.2.4 Field QA/QC Results..... | II-24 |
| 2.2.5 Exceptions to Test Protocol Document Procedures | II-24 |
| 3.0 PILOT TEST RESULTS | II-26 |
| 3.1 Fire Protection Training Area No. 1 (Site 3)..... | II-26 |
| 3.1.1 Initial Soil-Gas Chemistry | II-26 |
| 3.1.2 Air Permeability..... | II-26 |

TABLE OF CONTENTS (continued)

3.1.3 Oxygen Influence II-26
3.1.4 *In situ* Respiration Rates II-32
3.1.5 Potential Air Emissions II-39
3.1.6 Recommendations..... II-41
3.2 Bulk Fuel Storage Area (Site 18)..... II-41
3.2.1 Initial Soil-Gas Chemistry II-41
3.2.2 Air Permeability..... II-41
3.2.3 Oxygen Influence II-47
3.2.4 *In situ* Respiration Rates II-47
3.2.5 Potential Air Emissions II-55
3.2.6 Recommendations..... II-55
4.0 REFERENCES..... II-58

- APPENDIX A: GEOLOGIC BORING LOGS
- APPENDIX B: O & M MANUAL AND DATA COLLECTION SHEET
- APPENDIX C: CHAIN OF CUSTODY FORMS

LIST OF FIGURES

| <u>Figure</u> | <u>Page</u> |
|---|-------------|
| 1.1 As-Built Vent Well, Vapor Monitoring Point and Blower Locations, IRP Site 3: Fire Protection Training Area No. 1..... | II-2 |
| 1.2 Geologic Cross-Section, IRP Site 3: Fire Protection Training Area No. 1..... | II-4 |
| 1.3 As-Built Injection Vent Well Construction Detail, IRP Site 3: Fire Protection Training Area No. 1..... | II-7 |
| 1.4 As-Built Vapor Monitoring Point Construction Detail, IRP Site 3: Fire Protection Training Area, No. 1..... | II-8 |
| 1.5 As-Built Blower System Instrumentation Diagram for Air Injection, IRP Site 3: Fire Protection Training Area No. 1..... | II-10 |
| 1.6 As-Built Vent Well, Vapor Monitoring Point, and Blower Locations, IRP Site 18: Bulk Fuel Storage Area..... | II-11 |
| 1.7 Geologic Cross-Section, IRP Site 18: Bulk Fuel Storage Area..... | II-14 |
| 1.8 As-Built Injection Vent Well Construction Detail, IRP Site 18: Bulk Fuel Storage Area..... | II-17 |
| 1.9 As-Built Vapor Monitoring Point Construction Detail, IRP Site 18: Bulk Fuel Storage Area..... | II-18 |
| 1.10 As-Built Blower System Instrumentation Diagram for Air Injection, IRP Site 18: Bulk Fuel Storage Area..... | II-20 |
| 3.1 Air-Permeability Test, Monitoring Point VMP-1, IRP Site 3..... | II-28 |
| 3.2 Air-Permeability Test, Monitoring Point VMP-2, IRP Site 3..... | II-29 |
| 3.3 Air-Permeability Test, Monitoring Point VMP-3, IRP Site 3..... | II-30 |
| 3.4 Respiration Test, Vent Well, IRP Site 3..... | II-33 |
| 3.5 Respiration Test, Monitoring Point VMP 1-14, IRP Site 3..... | II-34 |
| 3.6 Respiration Test, Monitoring Point VMP 1-24, IRP Site 3..... | II-35 |
| 3.7 Respiration Test, Monitoring Point VMP 2-14, IRP Site 3..... | II-36 |

LIST OF FIGURES (continued)

| | | |
|------|---|-------|
| 3.8 | Respiration Test, Oxygen and Helium Concentrations, Monitoring Point VMP 1-14, IRP Site 3..... | II-38 |
| 3.9 | Air-Permeability Test, Monitoring Point VMP 1-6 and VMP 1-11, IRP Site 18..... | II-43 |
| 3.10 | Air-Permeability Test, Monitoring Point VMP 1-30 and VMP 1-65, IRP Site 18..... | II-44 |
| 3.11 | Air-Permeability Test, Monitoring Point VMP 2, IRP Site 18..... | II-45 |
| 3.12 | Air-Permeability Test, Monitoring Point VMP-3, IRP Site 18..... | II-46 |
| 3.13 | Respiration Test, Monitoring Point VMP-1-6, IRP Site 18..... | II-49 |
| 3.14 | Respiration Test, Monitoring Point VMP 1-11, IRP Site 18..... | II-50 |
| 3.15 | Respiration Test, Monitoring Point VMP 2-11, IRP Site 18..... | II-51 |
| 3.16 | Respiration Test, Monitoring Point VMP 3-55, IRP Site 18..... | II-52 |
| 3.17 | Respiration Test, Oxygen and Helium Concentrations, Monitoring Point VMP 1-11, IRP Site 18..... | II-54 |

LIST OF TABLES

| <u>Table</u> | <u>Page</u> |
|---|-------------|
| 1.1 Borehole, Soil Sample, and VMP/VW Summary Data, IRP Site 3: Fire Protection Training Area No. 1..... | II-3 |
| 1.2 VMP/VW Construction Data, IRP Site 3: Fire Protection Training Area No. 1..... | II-6 |
| 1.3 Borehole, Soil Sample, and VMP/VW Summary Data, IRP Site 18: Bulk Fuel Storage Area | II-12 |
| 1.4 VMP/VW Construction Data, IRP Site 18: Bulk Fuel Storage Area..... | II-16 |
| 2.1 Soil and Soil Gas Analytical Results IRP Site 3: Fire Protection Training Area No. 1..... | II-22 |
| 2.2 Soil and Soil Gas Analytical Results IRP Site 18: Bulk Fuel Storage Area..... | II-27 |
| 3.1 Initial Soil Gas Chemistry, IRP Site 3..... | II-27 |
| 3.2 Influence of Air Injection at Vent Well on Monitoring Point Oxygen Levels, IRP Site 3..... | II-31 |
| 3.3 Oxygen Utilization Rates, IRP Site 3..... | II-37 |
| 3.4 Pilot Test Data Summary, IRP Site 3..... | II-40 |
| 3.5 Initial Soil Gas Chemistry, IRP Site 18..... | II-42 |
| 3.6 Influence of Air Injection at Vent Well On Monitoring Point Oxygen Levels, IRP Site 18..... | II-48 |
| 3.7 Oxygen Utilization Rates, IRP Site 18..... | II-53 |
| 3.8 Pilot Test Data Summary, IRP Site 18..... | II-56 |

PART II
DRAFT INTERIM PILOT TEST RESULTS REPORT FOR
INSTALLATION RESTORATION PROGRAM SITES 3 AND 18
FIRE PROTECTION TRAINING AREA No. 1 (Site 3)
and BULK FUEL STORAGE AREA (Site 18)

Beale AFB, California

Initial bioventing pilot tests were completed at two Installation Restoration Program (IRP) sites at Beale Air Force Base, California: the Fire Protection Training Area (FPTA) No. 1 (IRP Site 3); and, the Bulk Fuel Storage Area (IRP Site 18). The purpose of this Part II Interim Report is to describe the results of the initial pilot test at each site and make specific recommendations for the extended (one-year) pilot tests which will determine the long-term impact of bioventing on site contaminants. Site histories, known contamination distributions and concentrations, and geologic/hydrogeologic profiles are documented in Part I, Bioventing Pilot Test Work Plan.

1.0 PILOT TEST DESIGN AND CONSTRUCTION

1.1 Fire Protection Training Area No. 1 (Site 3)

Installation of a central Vent Well (VW) and four Vapor Monitoring Points (VMPs) was conducted at the FPTA No. 1 between 19 October and 29 October 1992. Locations of the VW, VMPs, and abandoned boreholes are shown on Figure 1.1. The background VMP (VMP-4) was located approximately 300 feet northeast of the VW. Borehole drilling services were provided by PC Exploration, Inc. of Roseville, California. Soil sampling and well installation was directed on-site by Mr. Henry Pietropaoli and Mr. Frederick Stanin, R.G. of the ES-Alameda office.



Eleven boreholes were drilled at the site; five were converted to VMPs and the VW, and six were abandoned with bentonite/cement grout to the surface. This number of boreholes was necessary, in part, to find the most contaminated locations within the FPTA No. 1 for proper VW and VMP siting. Split-spoon soil samples were collected for field organic vapor analysis (OVA) to determine appropriate VW and VMP screened intervals and total depths. Both a total hydrocarbon vapor analyzer (THVA) and photoionization detector (PID) were used to screen field samples. Soil samples were also collected for laboratory analysis. Table 1.1 summarizes pertinent borehole data.

Figure 1.2 is a geologic cross-section of the pilot test site using data from the VW and three VMPs (the background VMP is not shown). The interpreted soil profile is shown along with OVA readings, VW and VMP screened intervals, and TRPH concentrations from laboratory analysis of soil samples. The soil boring logs are included as Appendix A. The near surface soils (upper 10 to 12 feet) are predominantly silty clays with some evidence of fill or disturbed material near the surface. This fill was probably the result of abandonment of the FPTA No. 1. A sand layer ranging from 4 to 7 feet in thickness occurs down to about 17 feet bgs. Below this sand is another clay to silty clay zone of about 10 feet in thickness. At the base of the observed soil profile is a zone that grades laterally from a sandy/gravelly clay at VW-1 to a silty sand at VMP-3, and grades vertically downward to a gravel of unknown thickness.

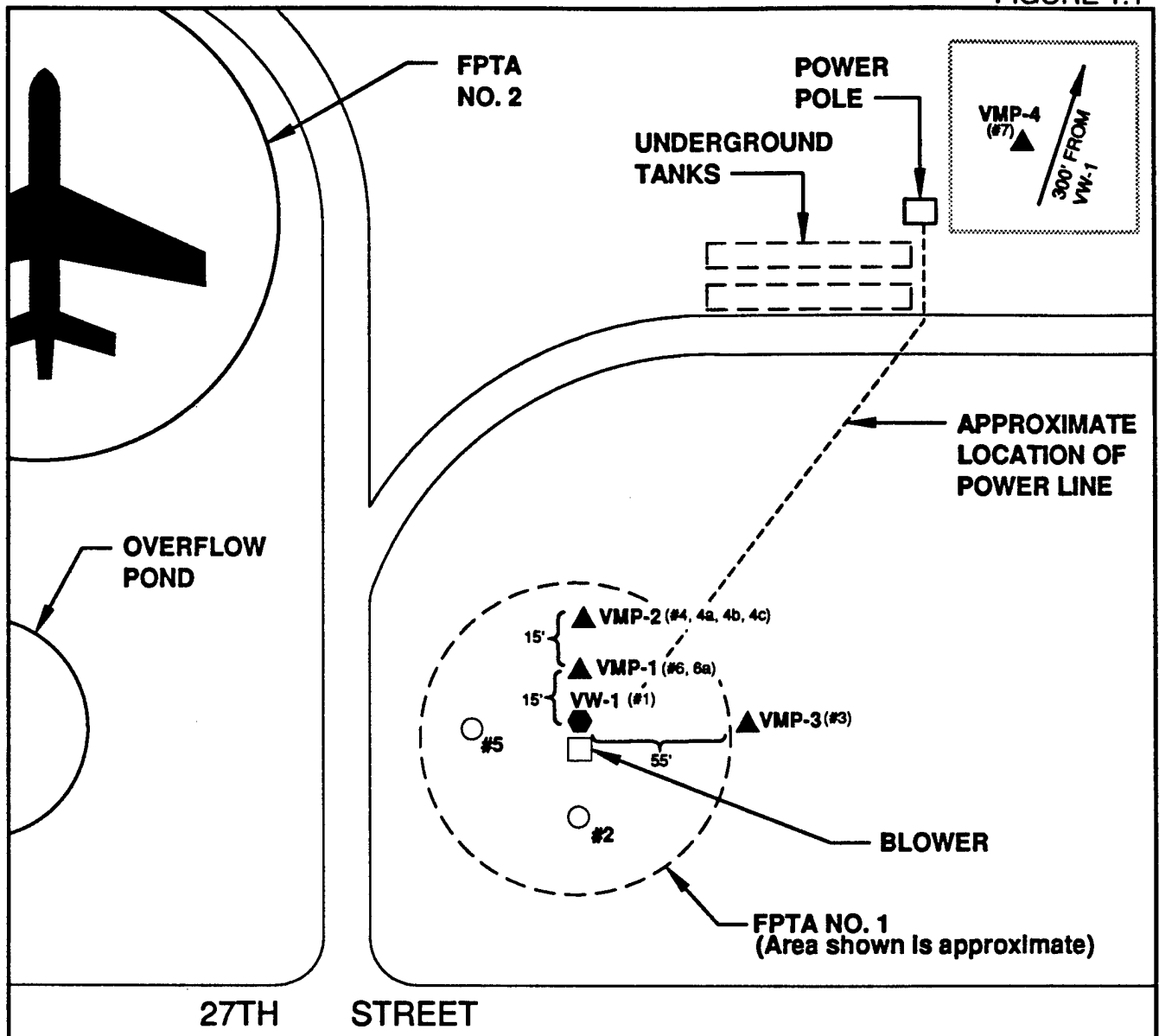
FIGURE 1.1



EXPLANATION

-  **VW-1 (#1)** VW LOCATION (and soil boring number)
-  **VMP-2 (#4)** VMP LOCATION (and soil boring number)
-  **#5** ABANDONED SOIL BORING (and soil boring number)



**AS-BUILT VW, VMP, AND
BLOWER LOCATIONS**

**IRP SITE 3
FIRE PROTECTION TRAINING AREA NO. 1**

**BEALE AIR FORCE BASE
CALIFORNIA**

TABLE 1.1
BOREHOLE, SOIL SAMPLE, VMP/VW SUMMARY DATA
IRP Site 3: Fire Protection Training Area No. 1
Beale AFB, California

| BOREHOLE ID # | BOREHOLE TOTAL DEPTH (ft. bgs) | SPLIT-SPOON INTERVAL (ft. bgs) | THVA/PID HEADSPACE READINGS (PPM) | SOIL SAMPLE ID # | START DATE | COMPLETION DATE | COMPLETION DESIGNATION |
|---------------|--------------------------------|--------------------------------|-----------------------------------|------------------|------------|-----------------|------------------------|
| 1 | 31.5 | 5.0 - 6.5 | 62/78 | - | 19Oct92 | 28Oct92 | VW-1 |
| | | 10.0 - 11.5 | 360/470 | BE3-VW-10 | | | |
| | | 15.0 - 16.5 | 22/68 | - | | | |
| | | 20.0 - 21.5 | 24/96 | - | | | |
| | | 25.0 - 26.5 | 15/8 | - | | | |
| | | 30.0 - 31.5 | 4/31 | - | | | |
| 2 | 31.5 | 5.0 - 6.5 | 42/183 | - | 20Oct92 | 28Oct92 | Abandoned |
| | | 10.0 - 11.5 | 180/436 | - | | | |
| | | 15.0 - 16.5 | 16/424 | - | | | |
| | | 20.0 - 21.5 | 2/40 | - | | | |
| | | 25.0 - 26.5 | 0/35 | - | | | |
| | | 30.0 - 31.5 | 0/78 | - | | | |
| 3 | 30.0 | 5.0 - 6.5 | 0/52 | - | 21Oct92 | 27Oct92 | VMP-3 |
| | | 10.0 - 11.5 | 2/1 | - | | | |
| | | 15.0 - 16.5 | 0/5 | - | | | |
| | | 20.0 - 21.5 | 0/0 | - | | | |
| | | 25.0 - 26.5 | 0/2 | - | | | |
| 4 | 11.5 | 5.0 - 6.5 | 120/435 | - | 21Oct92 | 28Oct92 | Abandoned |
| | | 10.0 - 11.5 | 380/578 | - | | | |
| 4a | 25.0 | 8.0 - 9.5 | 380/669 | - | 21Oct92 | 28Oct92 | Abandoned |
| | | 13.0 - 14.5 | 0/22 | - | | | |
| | | 18.0 - 19.5 | 1/13 | - | | | |
| | | 23.5 - 25.0 | 0/0 | - | | | |
| 4b | 4.0 | - | - | - | 22Oct92 | 28Oct92 | Abandoned |
| 4c | 26.3 | 8.0 - 9.5 | 610/860 | BE3-VMP2-9 | 22Oct92 | 23Oct92 | VMP-2 |
| 5 | 11.5 | 5.0 - 6.5 | 180/571 | - | 21Oct92 | 28Oct92 | Abandoned |
| | | 10.0 - 11.5 | 0/22 | - | | | |
| 6 | 25.5 | 8.0 - 9.5 | 190/281 | BE3-VMP1-9 | 23Oct92 | 26Oct92 | VMP-1 |
| | | 13.0 - 14.5 | 160/285 | - | | | |
| | | 18.0 - 19.5 | 13/32 | - | | | |
| | | 23.5 - 25.0 | 7/10 | - | | | |
| 6a | 8.5 | - | - | - | 23Oct92 | 28Oct92 | Abandoned |
| 7 | 29.0 | 5.0 - 6.5 | 0/4 | - | 28Oct92 | 29Oct92 | VMP-4 |
| | | 10.0 - 11.5 | 0/0 | - | | | |
| | | 14.5 - 16.0 | 0/17 | - | | | |
| | | 20.0 - 21.5 | 0/9 | - | | | |
| | | 25.0 - 26.5 | 0/16 | - | | | |
| | | 27.5 - 29.0 | 0/14 | - | | | |

FIGURE 1.2

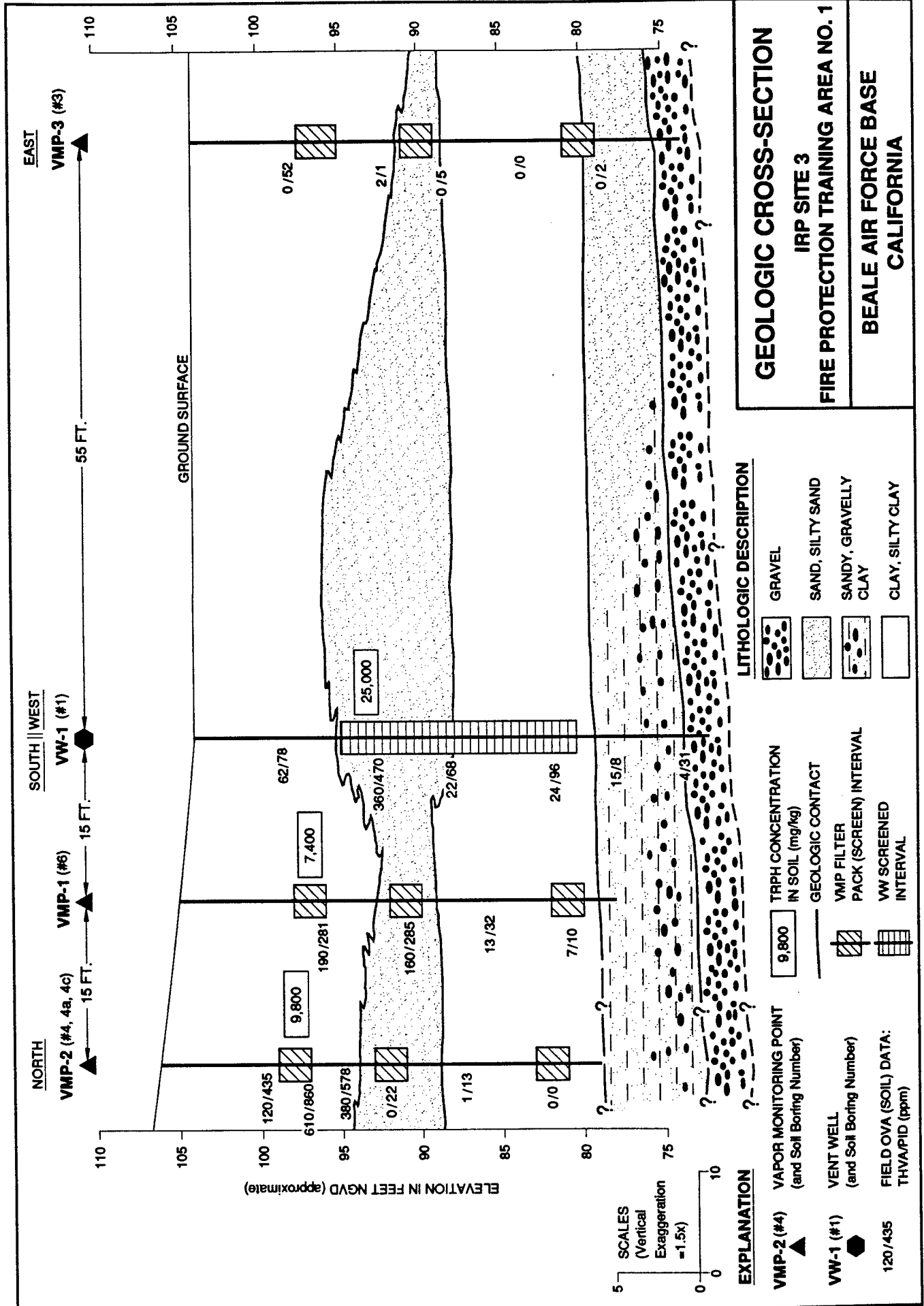

The boreholes were not advanced below 31.5 feet bgs because of the low OVA readings in the lower portion of the observed soil profile (see Table 1.1 and Figure 1.2). The vent well was completed above the gravel layer to prevent preferential air movement into the lower gravel unit. Groundwater at the site was not encountered; the water table at the site is approximately 100 feet bgs (Part I, Section 2.1.2).

1.1.1 Air Injection Vent Well

The air injection Vent Well (VW-1) was installed at a location of highly contaminated soil following procedures described in the protocol document (Hinchee et al., 1992). Table 1.2 shows construction data and Figure 1.3 shows construction details of VW-1. The borehole was backfilled with bentonite from 31.5 feet bgs to 25.0 feet bgs to seal off the well from the highly permeable gravels. VW-1 was constructed using 4-inch ID, Schedule 40 PVC casing and slotted screen (0.040-inch slot size). The annular space adjacent to the screen was filled with 6-12 Lone Star sand (filter pack) from the top of the bentonite backfill to 2 feet above the top of the screen. To prevent preferential air movement near the surface, an approximate 2-foot thick annular bentonite seal was emplaced on top of the sand followed by a bentonite/cement grout to within 2 feet of the surface. The well casing was connected directly to the portable blower unit for the initial pilot test and then to the fixed blower unit located adjacent to the well for the extended pilot test.

1.1.2 Vapor Monitoring Points

The four VMPs were installed (in the boreholes indicated in Table 1.1) in areas of variably-contaminated soil following procedures described in the protocol document (Hinchee et al., 1992). Table 1.2 shows construction data and Figure 1.4 shows construction details of the VMPs. Some variability exists among the VMPs in construction details as indicated in Table 1.2. Where needed, boreholes used for VMPs were partially backfilled to seal off the VMPs from the highly permeable gravels. All VMPs were constructed using 0.25-inch ID, Schedule 80 PVC casing and 1-inch ID slotted screened intervals (0.020-inch slot size). Three casing strings/screens were installed in each VMP borehole at depths of approximately 8, 14, and 24 feet bgs to provide monitoring points at variable depths, soil types, and contamination levels. The screened intervals were each 6 inches in length and were at the bottom of each individual PVC casing string. Each screen was centered in a 2-foot thick layer of 6-12 Lone Star sand (filter pack). These filter pack intervals were sealed above and below with bentonite. A sampling valve was coupled at the top of each casing string. In VMP-1, thermocouples were installed adjacent to the 8-foot and 14-foot screens to allow measurement of soil temperature. The surface of each VMP was completed with a flush-mounted well box set in a concrete base.

1.1.3 Blower Units

A portable 3.0-horsepower Roots™ positive displacement blower unit was used for the initial pilot test. A fixed 2.5-horsepower (HP) Gast™ regenerative blower unit was installed on 11 November 1992 for the extended pilot test. The portable unit was powered by a 230-V, single-phase, 30-A line from an above-ground power line and breaker provided by the base. The fixed unit is powered by the 230-V, single-phase,

TABLE 1.2
VMP/VW CONSTRUCTION DATA
 IRP Site 3: Fire Protection Training Area No. 1
 Beala AFB, California

| WELL ID # | BOREHOLE TOTAL DEPTH (ft. bgs) | VW SCREEN INTERVAL (ft. bgs) | CENTER of VMP SCREEN (ft. bgs) | FILTER PACK INTERVAL(s) (ft. bgs) | BENTONITE INTERVAL(s) (ft. bgs) | GROUT INTERVAL(s) (ft. bgs) |
|-----------|--------------------------------|------------------------------|--------------------------------|-----------------------------------|---------------------------------|-----------------------------|
| VW-1 | 31.5 | 9.5 - 23.9 | - | 7.5 - 25.5 | 5.7 - 7.5 | 2.0 - 5.7 |
| | | | | - | 25.5 - 31.5 | |
| VMP-1 | 25.5 | - | 8.0 | 7.0 - 9.0 | 4.0 - 7.0 | None |
| | | | 14.0 | 13.0 - 15.0 | 9.0 - 13.0 | |
| | | | 24.0 | 23.0 - 25.5 | 15.0 - 17.0 | |
| | | | | | 21.0 - 23.0 | |
| VMP-2 | 26.3 | - | 8.0 | 6.9 - 9.0 | 3.0 - 6.9 | None |
| | | | 14.0 | 13.0 - 15.2 | 9.0 - 13.0 | |
| | | | 24.0 | 23.0 - 25.2 | 15.2 - 23.0 | |
| | | | | | 25.2 - 26.3 | |
| VMP-3 | 30.0 | - | 8.0 | 6.5 - 9.0 | 5.5 - 6.5 | None |
| | | | 14.0 | 13.0 - 15.0 | 9.0 - 13.0 | |
| | | | 24.0 | 23.0 - 25.0 | 15.0 - 23.0 | |
| | | | | | 25.0 - 30.0 | |
| VMP-4 | 29.0 | - | 8.0 | 6.5 - 9.0 | 2.0 - 6.5 | None |
| | | | 15.0 | 14.0 - 16.0 | 9.0 - 14.0 | |
| | | | 24.0 | 23.0 - 25.0 | 16.0 - 23.0 | |
| | | | | | 25 - 29.0 | |

FIGURE 1.3

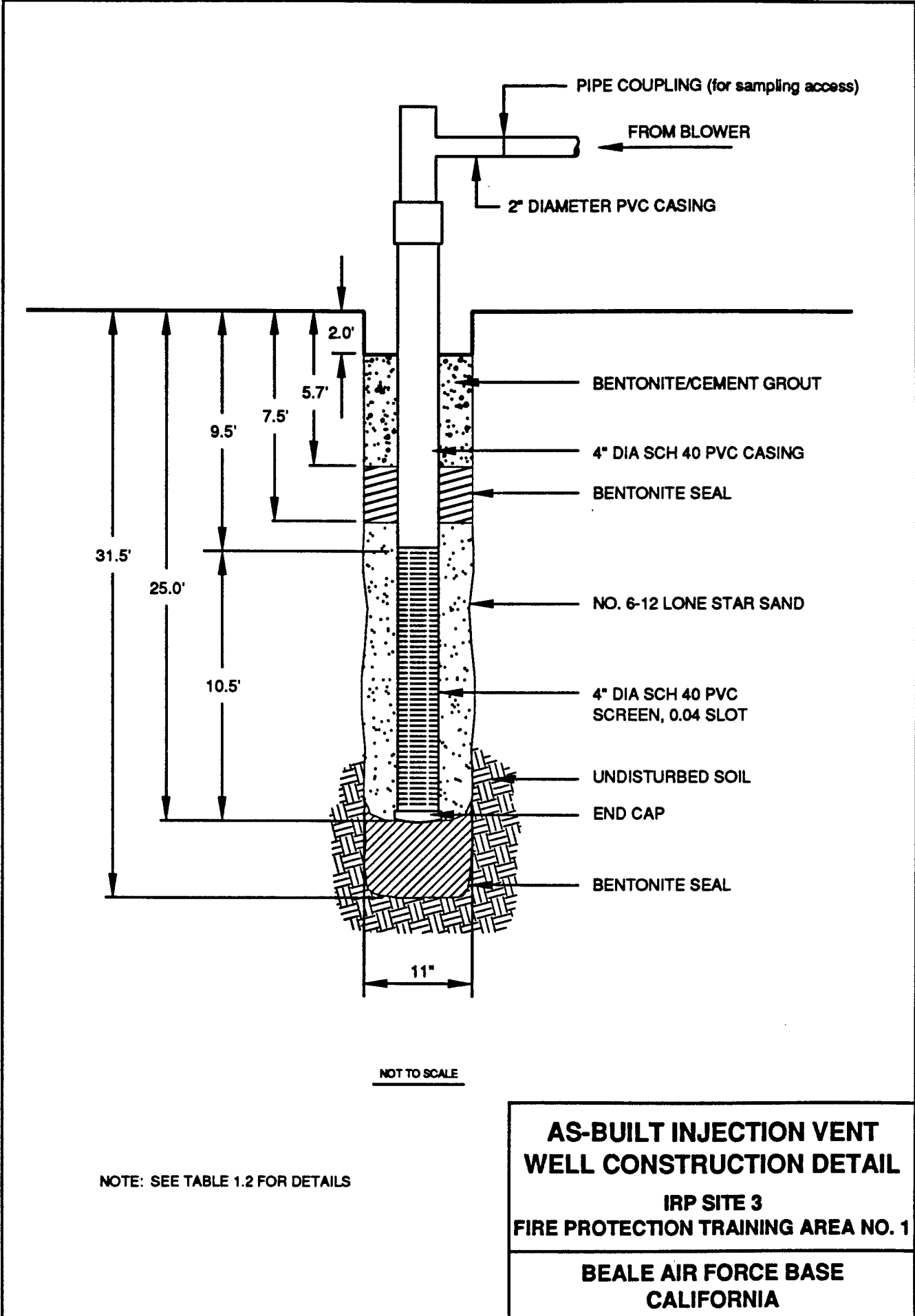
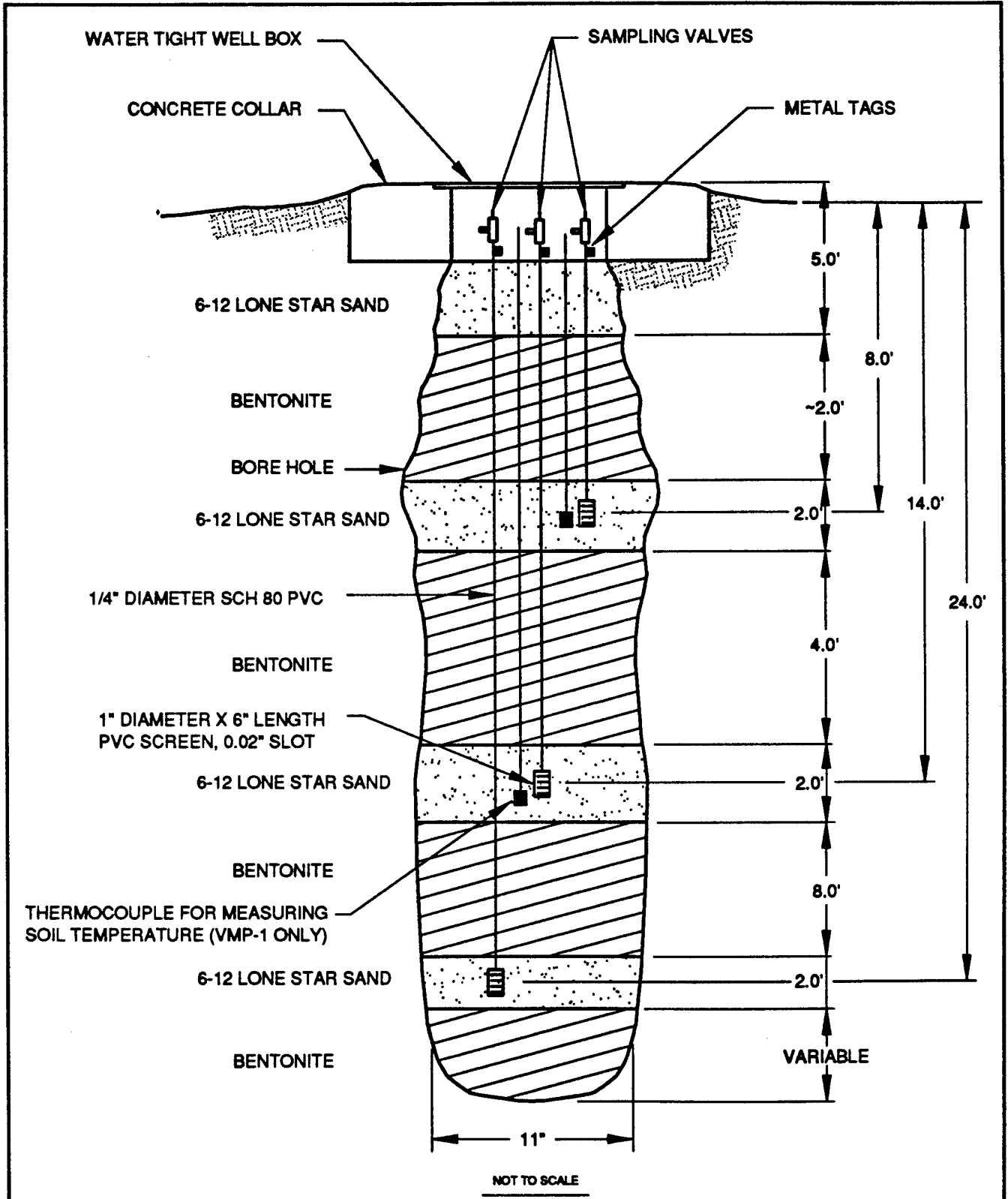

FIGURE 1.4



NOTE: SEE TABLE 1.2 FOR DETAILS

**AS-BUILT VAPOR MONITORING
POINT CONSTRUCTION DETAIL**

**IRP SITE 3
FIRE PROTECTION TRAINING AREA NO. 1**

**BEALE AIR FORCE BASE
CALIFORNIA**

ENGINEERING-SCIENCE, INC.

30-A line used by the portable unit. Locations of the power pole, power line, and blower are shown on Figure 1.1. The fixed blower unit is currently injecting approximately 30 standard cubic feet per minute (scfm) for the extended pilot test. The configuration, instrumentation, and specifications for this system are shown on Figure 1.5. ES personnel provided an operations and maintenance (O&M) data collection sheet and blower maintenance manual to base personnel before departing from the site. A copy of the data collection sheet and manual is provided as Appendix B.

1.1.4 Exceptions to Test Protocol Document Procedures

Procedures described in the protocol document (Hinchee et al., 1992) related to pilot test design and construction were used with the following exceptions:

- Borehole diameter for VMP-4 was 8 inches instead of 11 inches.
- Lone Star 6-12 sand was used for filter pack material in all VMPs and the VW instead of 6-9 silica sand.
- A thermocouple was installed adjacent to the middle VMP screen in VMP-1 instead of the deepest VMP screen.

1.2 Bulk Fuel Storage Area (Site 18)

Installation of a central Vent Well (VW) and three Vapor Monitoring Points (VMPs) was conducted along the railroad tracks at the north end of the AVGAS facilities within the Bulk Fuel Storage Area between 29 October and 10 November 1992. Locations of the VW and VMPs are shown on Figure 1.6. No background VMP was installed at the site; background levels of soil gas were derived from the background VMP at IRP Site 3 (VMP-4). Borehole drilling services were provided by PC Exploration, Inc. of Roseville, California. Soil sampling and well installation was directed on-site by Mr. Henry Pietropaoli of the ES-Alameda office.

Four boreholes were drilled at the site; one was converted to the VW and three were converted to VMPs. No boreholes were abandoned since contamination observed during drilling was at sufficient levels for VW and VMP siting. Split-spoon soil samples were collected for field organic vapor analysis (OVA) to determine appropriate VW and VMP screened intervals and total depths. A PID was used to screen field samples. Soil samples were also collected for laboratory analysis. Table 1.3 summarizes of all pertinent borehole data.

Figure 1.7 is a geologic cross-section of the pilot test site using data from the VW and the three VMPs. The interpreted soil profile is shown along with OVA readings, VW and VMP screened intervals, and TRPH concentrations from laboratory analysis of soil samples. The soil boring logs are included as Appendix A. The upper 4 feet of the profile is railroad ballast material of imported coarse gravel. Immediately below the ballast is a 4 to 6 foot thick layer of clayey silt that grades downward into a 3 to 6 foot thick layer of sand. This sand zone is fine-grained and clayey in VMP-3 and VMP-2 and becomes thicker and coarser-grained with no clay to the east in VMP-1 and VW-1. Below this sand layer are mostly clays and silty clays with some sporadic sandy clay zones. These clays extend 25 or 30 feet below the upper sand layer, except in VMP-3

FIGURE 1.5

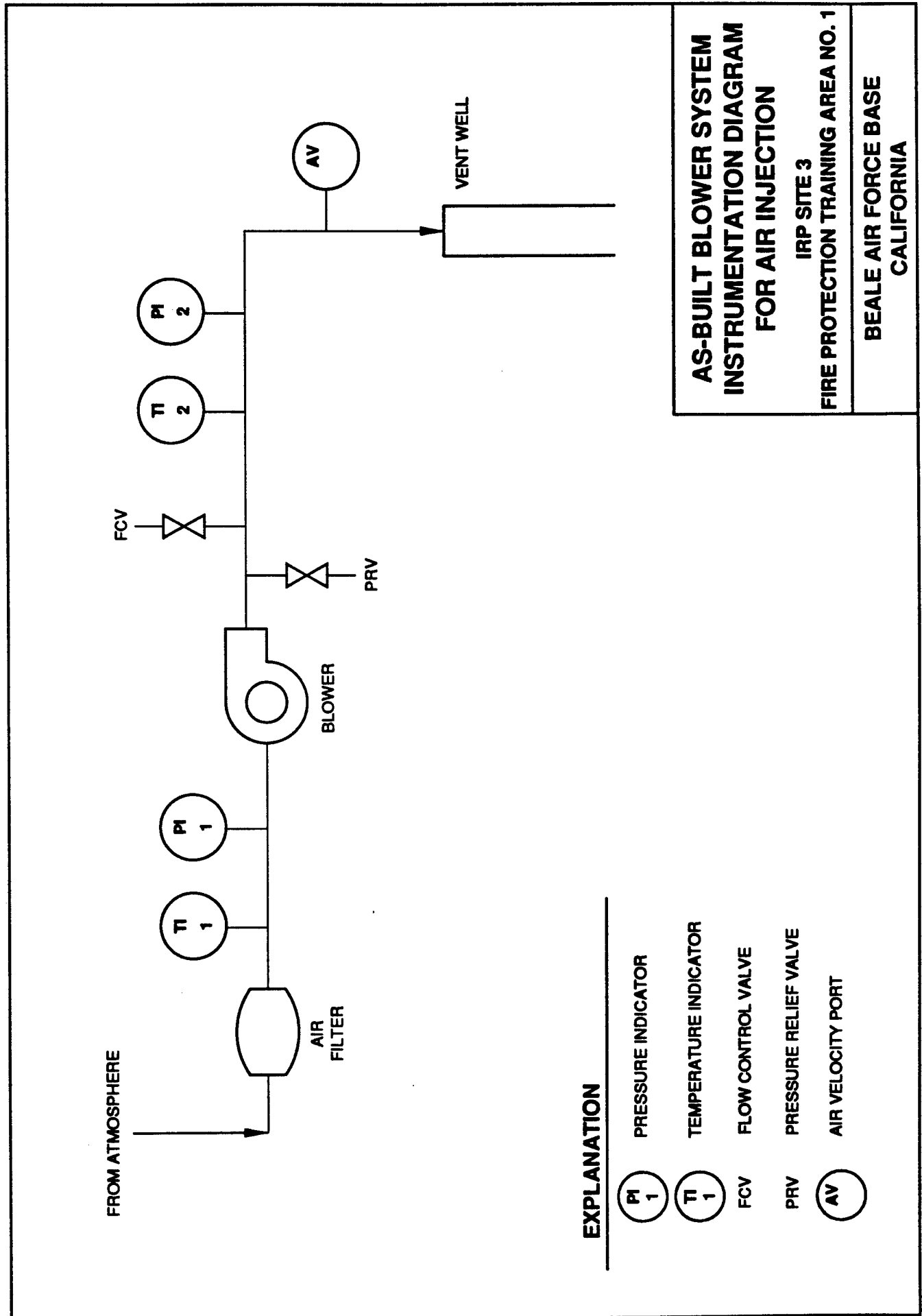

**AS-BUILT BLOWER SYSTEM
INSTRUMENTATION DIAGRAM
FOR AIR INJECTION**

IRP SITE 3

FIRE PROTECTION TRAINING AREA NO. 1

BEALE AIR FORCE BASE
CALIFORNIA

EXPLANATION



-  PRESSURE INDICATOR
-  TEMPERATURE INDICATOR
- FCV FLOW CONTROL VALVE
- PRV PRESSURE RELIEF VALVE
-  AIR VELOCITY PORT

FIGURE 1.6



AS-BUILT VW, VMP, AND BLOWER LOCATIONS

IRP SITE 18
BULK FUEL STORAGE AREA
(NORTHERN PORTION)

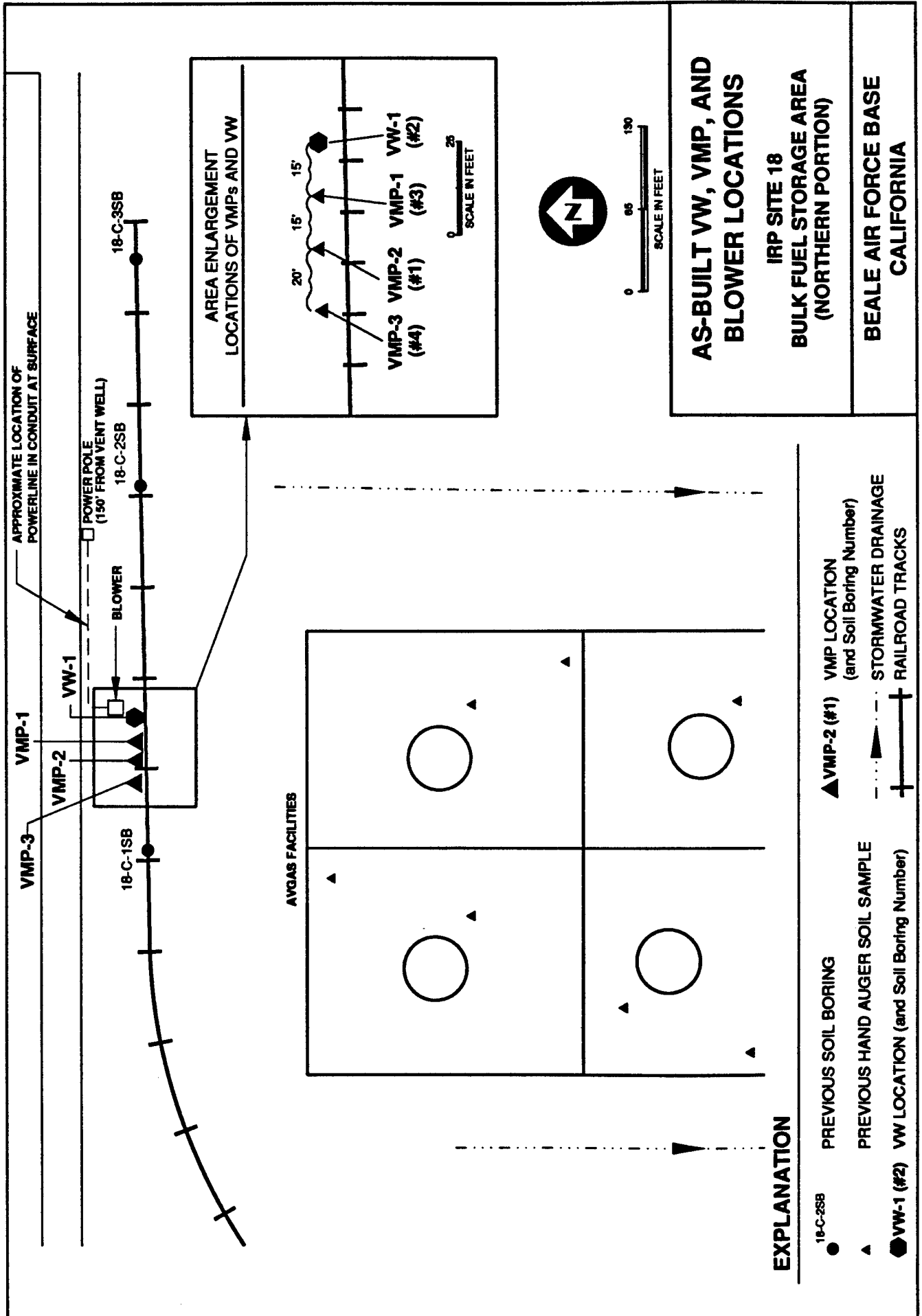
BEALE AIR FORCE BASE
CALIFORNIA

TABLE 1.3
BOREHOLE, SOIL SAMPLE, VMP/VW SUMMARY DATA
IRP Site 18: Bulk Fuel Storage Area
Beale AFB, California

| BOREHOLE ID # | BOREHOLE TOTAL DEPTH (ft. bgs) | SPLIT-SPOON INTERVAL (ft. bgs) | PID HEADSPACE READINGS (PPM) | SOIL SAMPLE ID # | START DATE | COMPLETION DATE | COMPLETION DESIGNATION |
|---------------|--------------------------------|--------------------------------|------------------------------|------------------|------------|-----------------|------------------------|
| 1 | 67.5 | 5.0 - 6.5 | 267 | - | 29Oct92 | 09Nov92 | VMP-2 |
| | | 9.5 - 11.0 | 1127 | BE18-VW-11 | | | |
| | | 14.0 - 15.5 | 0 | - | | | |
| | | 19.0 - 20.5 | 349 | - | | | |
| | | 27.0 - 28.5 | 78 | - | | | |
| | | 29.0 - 30.5 | 0 | - | | | |
| | | 35.0 - 36.5 | 0 | - | | | |
| | | 40.0 - 41.5 | 802 | - | | | |
| | | 45.0 - 46.5 | 148 | - | | | |
| | | 50.0 - 51.5 | 136 | - | | | |
| | | 55.0 - 56.5 | 743 | - | | | |
| | | 60.0 - 61.5 | 112 | - | | | |
| | | 64.5 - 66.0 | 246 | - | | | |
| | | 66.0 - 67.5 | NR | - | | | |
| 2 | 71.5 | 5.0 - 6.5 | 793 | - | 02Nov92 | 03Nov92 | VW-1 |
| | | 9.5 - 11.0 | 2753 | BE18-VW1-11 | | | |
| | | 11.0 - 12.5 | 628 | - | | | |
| | | 14.5 - 16.0 | 306 | - | | | |
| | | 19.0 - 20.5 | 189 | - | | | |
| | | 22.5 - 24.0 | 227 | - | | | |
| | | 33.5 - 35.0 | 235 | - | | | |
| | | 40.0 - 41.5 | 249 | - | | | |
| | | 45.0 - 46.5 | 430 | - | | | |
| | | 50.0 - 51.5 | 269 | - | | | |
| | | 55.0 - 56.5 | 282 | - | | | |
| | | 60.0 - 61.5 | 407 | - | | | |
| | | 65.0 - 66.5 | 71 | - | | | |
| | | 70.0 - 71.5 | 25 | - | | | |
| 3 | 70.0 | 5.0 - 6.5 | 963 | - | 03Nov92 | 05Nov92 | VMP-1 |
| | | 9.5 - 11.0 | 1640 | - | | | |
| | | 11.0 - 12.5 | 1700 | BE18-VMP1-12.5 | | | |
| | | 14.0 - 15.5 | 257 | - | | | |
| | | 20.0 - 21.5 | 411 | - | | | |
| | | 24.5 - 26.0 | 366 | - | | | |
| | | 29.0 - 30.5 | 1530 | - | | | |
| | | 33.5 - 35.0 | 215 | - | | | |
| | | 39.5 - 41.0 | 324 | - | | | |
| | | 44.0 - 45.5 | 267 | - | | | |
| | | 48.5 - 50.0 | 544 | - | | | |
| | | 54.5 - 56.0 | 509 | - | | | |
| | | 59.0 - 60.5 | 676 | - | | | |
| | | 64.0 - 65.5 | 489 | - | | | |
| 68.0 - 70.0 | 218 | - | | | | | |

TABLE 1.3
BOREHOLE, SOIL SAMPLE, VMP/VW SUMMARY DATA
 IRP Site 18: Bulk Fuel Storage Area
 Beale AFB, California

| BOREHOLE ID # | BOREHOLE TOTAL DEPTH (ft. bgs) | SPLIT-SPOON INTERVAL (ft. bgs) | PID HEADSPACE READINGS (PPM) | SOIL SAMPLE ID # | START DATE | COMPLETION DATE | COMPLETION DESIGNATION |
|---------------|--------------------------------|--------------------------------|------------------------------|------------------|------------|-----------------|------------------------|
| 4 | 69.0 | 5.0 - 6.5 | 610 | - | 10Nov92 | 10Nov92 | VMP-3 |
| | | 10.0 - 11.5 | 387 | - | | | |
| | | 15.0 - 16.5 | 684 | - | | | |
| | | 20.0 - 21.5 | 366 | - | | | |
| | | 25.0 - 26.5 | 278 | - | | | |
| | | 30.0 - 31.5 | 212 | - | | | |
| | | 35.0 - 36.5 | 382 | - | | | |
| | | 40.0 - 41.5 | 379 | - | | | |
| | | 45.0 - 46.5 | 802 | - | | | |
| | | 50.0 - 51.5 | 303 | - | | | |
| | | 55.0 - 56.5 | 1165 | BE18-VMP3-55 | | | |
| | | 60.0 - 61.5 | 86 | - | | | |
| | | 65.0 - 66.5 | 32 | - | | | |

BEALTAB3.WK1

FIGURE 1.7

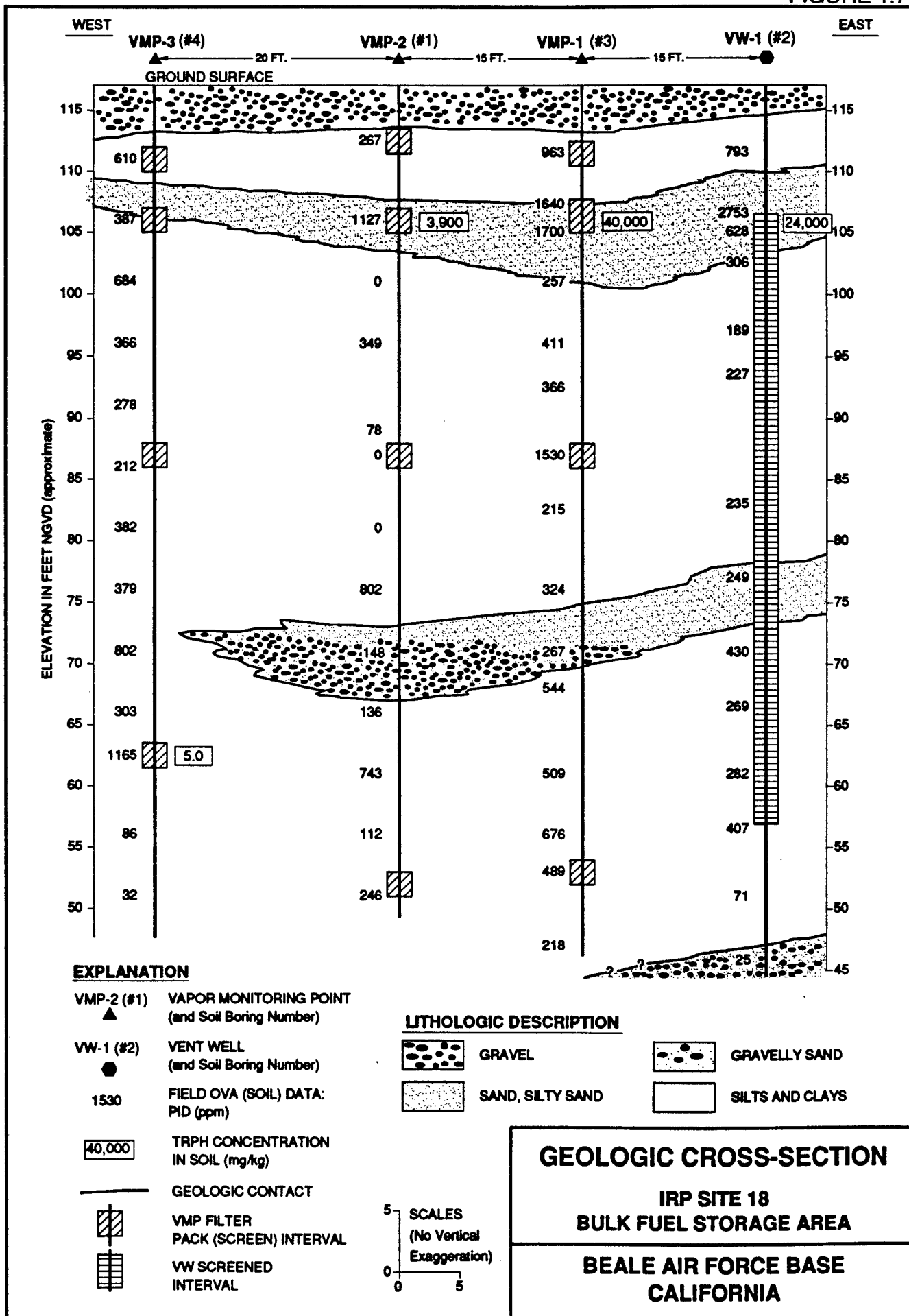

where the clays persist to the total depth of the borehole (69 feet bgs). A 5 to 6 foot thick sand layer is below these clays in VMP-1, VMP-2, and VW-1. This sand is gravelly to the west and then laterally pinches out. Below this sand layer are silty clays with rare sandy clays that extend to total depth of all wells except VW-1 where a gravelly sand of unknown thickness was encountered at 70 feet bgs.

None of the boreholes were advanced below 71.5 feet bgs because of relatively low OVA readings in the lower portion of the observed soil profile (see Table 1.3 and Figure 1.7). All the wells were completed above the gravelly sand zone found at the base of the VW-1 borehole. Groundwater at the site was not encountered; the water table at the site is approximately 105 feet bgs (see Part I).

1.2.1 Air Injection Vent Well

The air injection Vent Well (VW-1) was installed at a location of highly contaminated soil following procedures described in the protocol document (Hinchee et al., 1992). Table 1.4 shows construction data and Figure 1.8 shows construction details of VW-1. The borehole was backfilled with bentonite from 71.5 feet bgs to 60.0 feet bgs to seal off the well from the sandy gravel found at the base of the borehole. The VW was constructed using 4-inch ID, Schedule 40 PVC casing and slotted screen (0.040-inch slot size). The annular space adjacent to the screen was filled with 6-12 Lone Star sand (filter pack) from the top of the bentonite backfill to 2 feet above the top of the screen. An approximately 4-foot thick annular bentonite seal was emplaced on top of the sand followed by a bentonite/cement grout to within 2 feet of the surface. The well casing was connected directly to the portable blower unit for the initial pilot test and then to the fixed blower unit located adjacent to the well for the extended pilot test.

1.2.2 Vapor Monitoring Points

The three VMPs were installed (in the boreholes indicated in Table 1.3) in areas of variably-contaminated soil following procedures described in the protocol document (Hinchee et al., 1992). Table 1.4 shows construction data and Figure 1.9 shows construction details of the VMPs. Some variability exists among the VMPs in construction details as indicated in Table 1.4. For example, the lowermost screened interval in VMP-3 was placed 10 feet higher than the equivalent screens in VMP-1 and VMP-2 because of the comparatively high OVA reading at 55 feet bgs (see Figure 1.7). Where needed the boreholes were partially backfilled to the base of the lowest screened interval. All VMPs were constructed using 0.25-inch ID, Schedule 80 PVC casing and 1-inch ID slotted screened intervals (0.020-inch slot size). Four casing strings/screens were installed in each VMP borehole at depths of approximately 6, 11, 30, and 65 (55 in VMP-3) feet bgs to provide monitoring points at variable depths, soil types, and contamination levels. The screened intervals were each 6 inches in length and were at the bottom of each individual PVC casing string. Each screen was centered in a 2-foot thick layer of 6-12 Lone Star sand (filter pack). These filter pack intervals were sealed above and below with bentonite. A sampling valve was coupled at the top of each casing string. In VMP-1, thermocouples were installed adjacent to the 5-foot and 64-foot screens to allow measurement of soil temperature. The surface of each VMP was completed with a flush-mounted well box set in a concrete base.

TABLE 1.4
VMP/VW CONSTRUCTION DATA
IRP Site 18: Bulk Fuel Storage Area
Beala AFB, California

| WELL ID # | BOREHOLE TOTAL DEPTH (ft. bgs) | VW SCREEN INTERVAL (ft. bgs) | CENTER of VMP SCREEN (ft. bgs) | FILTER PACK INTERVAL(s) (ft. bgs) | BENTONITE INTERVAL(s) (ft. bgs) | GROUT INTERVAL(s) (ft. bgs) |
|-----------|--------------------------------|------------------------------|--------------------------------|-----------------------------------|---------------------------------|-----------------------------|
| VW-1 | 71.5 | 10.0 - 60.0 | - | 8.0 - 61.0 | 4.3 - 8.0 | 2.0 - 4.3 |
| | | | | - | 61.0 - 71.5 | |
| VMP-1 | 70.0 | - | 5.5 | 5.0 - 6.8 | 2.5 - 5.0 | None |
| | | | 11.0 | 9.5 - 12.0 | 6.8 - 9.0 | |
| | | | 30.2 | 29.0 - 31.0 | 12.0 - 29.0 | |
| | | | 64.0 | 63.0 - 64.9 | 31.0 - 63.0 | |
| | | | | | 64.9 - 71.5 | |
| VMP-2 | 67.5 | - | 5.0 | 3.5 - 5.5 | 2.0 - 3.5 | None |
| | | | 11.0 | 10.0 - 12.0 | 5.5 - 10.0 | |
| | | | 30.0 | 28.8 - 30.8 | 12.0 - 28.8 | |
| | | | 65.0 | 63.8 - 66.0 | 30.8 - 63.8 | |
| | | | | | 66.0 - 67.5 | |
| VMP-3 | 69.0 | - | 6.0 | 5.0 - 7.0 | 1.5 - 5.0 | None |
| | | | 11.0 | 10.0 - 12.0 | 7.0 - 10.0 | |
| | | | 30.0 | 29.0 - 31.0 | 12.0 - 29.0 | |
| | | | 55.0 | 54.0 - 56.0 | 31.0 - 54.0 | |
| | | | | | 56.0 - 69.0 | |

FIGURE 1.8

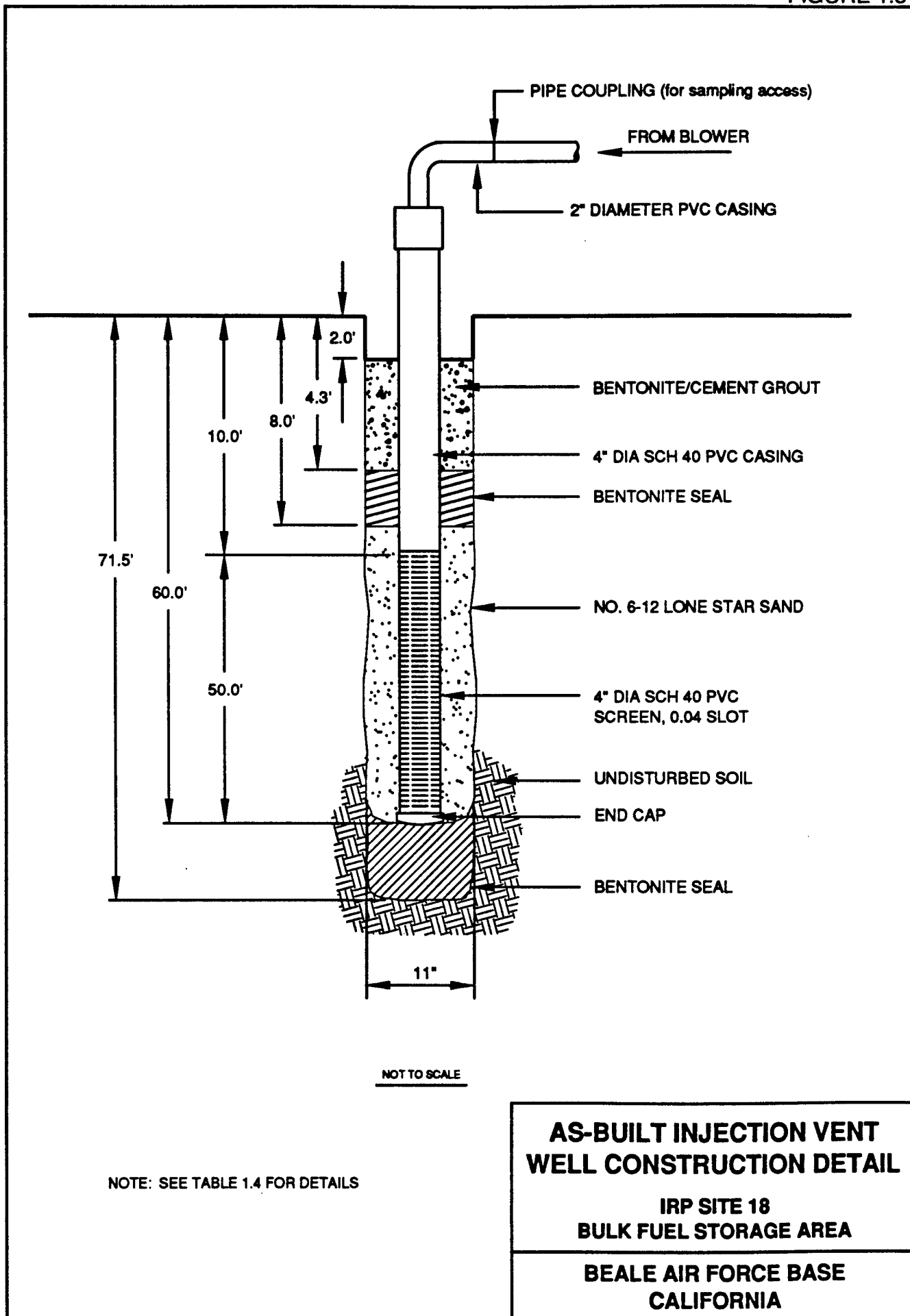

1.2.3 Blower Units

A portable 3.0-horsepower Roots™ positive displacement blower unit was used for the initial pilot test. A fixed 2.5-HP Gast™ regenerative blower unit was set-up on 19 November 1992 for the extended pilot test, and was installed on 14 January 1993 after explosion-proofing concerns were addressed. The portable unit was powered by a 230-V, single-phase, 30-A line from an above-ground power line and breaker provided by the base. The fixed unit is powered by the 230-V, single-phase, 30-A line used by the portable unit. Locations of the power pole, power line, and blower are shown on Figure 1.6. The fixed blower unit is currently injecting approximately 30 standard cubic feet per minute (scfm) for the extended pilot test. The configuration, instrumentation, and specifications for this system are shown on Figure 1.10. ES personnel provided an operations and maintenance (O&M) data collection sheet and blower maintenance manual to base personnel before departing from the site. A copy of the data collection sheet and manual is provided as Appendix B.

1.2.4 Exceptions to Test Protocol Document Procedures

Procedures described in the protocol document (Hinchee et al., 1992) related to pilot test design and construction were used with the following exceptions:

- Borehole diameter for all VMPs and the VW was 8 inches instead of 11 inches.
- Lonestar 6-12 sand was used for filter pack material in all VMPs and the VW instead of 6-9 silica sand.

FIGURE 1.10

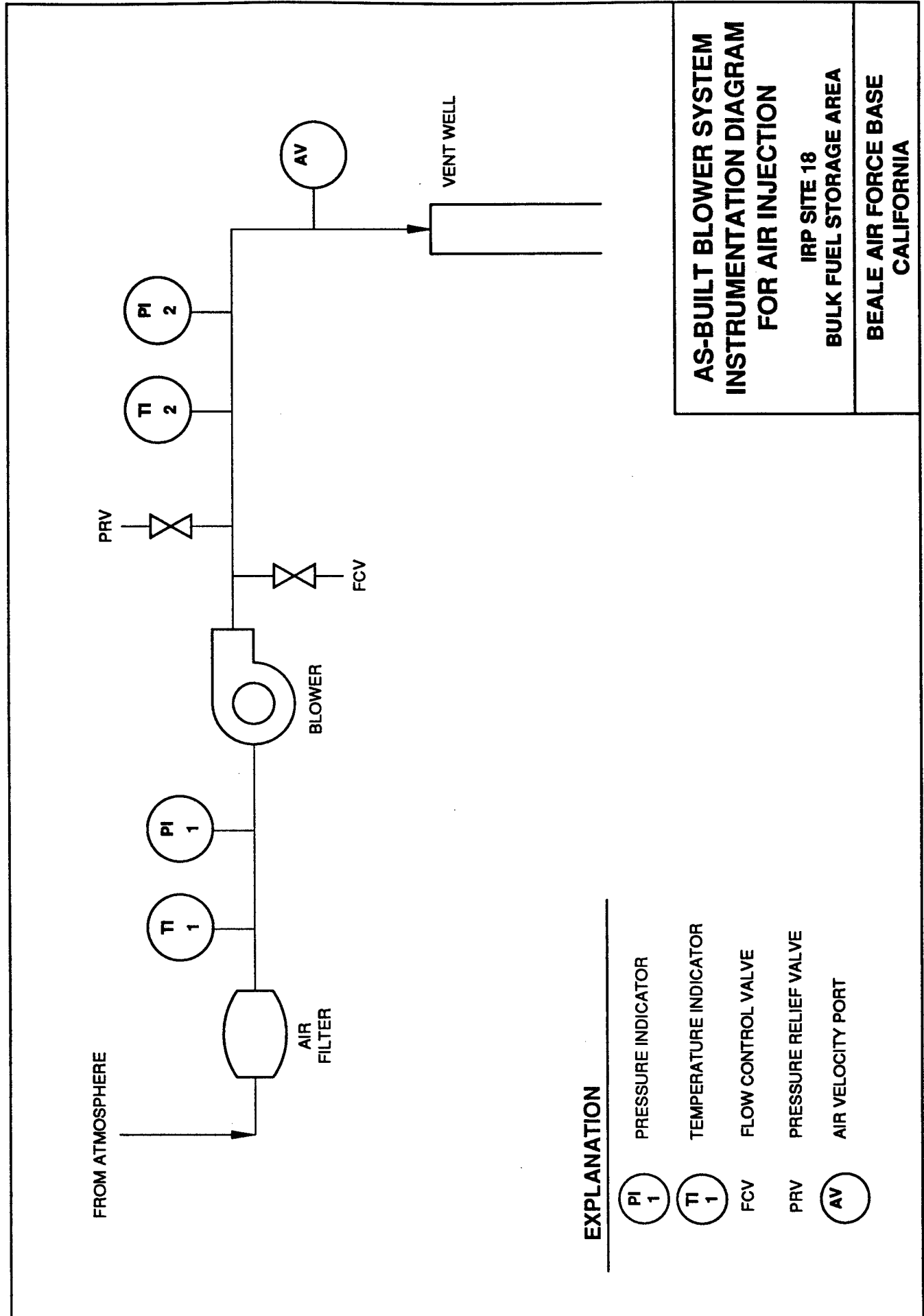

**AS-BUILT BLOWER SYSTEM
INSTRUMENTATION DIAGRAM
FOR AIR INJECTION**

IRP SITE 18
BULK FUEL STORAGE AREA

BEALE AIR FORCE BASE
CALIFORNIA

EXPLANATION

- PI 1 PRESSURE INDICATOR
- TI 1 TEMPERATURE INDICATOR
- FCV FLOW CONTROL VALVE
- PRV PRESSURE RELIEF VALVE
- AV AIR VELOCITY PORT

2.0 PILOT TEST SOIL AND SOIL-GAS SAMPLING RESULTS

2.1 Fire Protection Training Area No. 1 (Site 3)

2.1.1 Soil Sample Field Analysis

Contaminated soils were identified based on field observations such as visual appearance, odor, and OVA readings. OVA readings were monitored using both a photoionization detector (PID) and a total hydrocarbon vapor analyzer (THVA) on all soil samples in order to estimate the relative amount and extent of soil contamination detectable by such devices. OVA readings using the PID were consistently higher than the THVA readings (see Table 1.1).

Hydrocarbon contamination at the test site is probably confined to soils within the former FPTA No. 1 bermed area. VMP-3 may be located just outside of the former bermed area based on where the bermed area was thought to be and the field observations such as low OVA readings (see Table 1.1 and Figure 1.2). In addition, there was no staining or odor in the VMP-3 soil samples. All other boreholes, except for the background VMP, were located within the former bermed area and encountered observable soil contamination. Some soils had a blue-green discoloration and a fuel/paint (solvent)-like odor. The discoloration was limited to the upper 15 feet and was sporadic. The odor was only noted within the upper 20 feet and varied in intensity. These visual and sensory observations correlate with OVA readings which showed no readings exceeding 100 ppmv below 20 feet. The highest OVA readings were recorded in the shallow silty clays and the upper portion of the shallow sand layer (see Figure 1.2).

2.1.2 Soil Sample Laboratory Analysis

Soil samples for laboratory analysis were collected by using a hammer-driven split-spoon sampler lined with brass sleeves. The samples were preserved in the brass sleeves and capped with Teflon tape and plastic end-caps. Selection of soil samples for laboratory analysis was based on field OVA readings. Samples from VW-1, VMP-1, and VMP-2 boreholes with the highest OVA readings were selected for laboratory analysis and were collected from depths of 9 to 10 feet bgs (see Table 1.1).

The selected soil samples were either shipped via Federal Express or hand-delivered to the ES-Berkeley Laboratory (ESBL) for chemical and physical analysis. Analytes were: total recoverable petroleum hydrocarbons (TRPH); benzene, toluene, ethylbenzene, and total xylenes (BTEX); iron; alkalinity; pH; total Kjeldahl nitrogen; phosphates; moisture; and grain size distribution. Samples to be analyzed for total Kjeldahl nitrogen, phosphates, and grain size distribution were transferred to Sequoia Analytical in Redwood City, California. The results of all analyses are summarized in Table 2.1. The TRPH concentrations are also included on the geological cross section (Figure 1.2).

2.1.3 Soil-Gas Sample Laboratory Analysis

Subsurface soil-gas samples were collected for laboratory analysis in Summa[®] canisters. These samples were collected from the Vent Well (VW-1), the screen at 8 feet bgs in VMP-1, and the screen at 14 feet bgs in VMP-3 after purging the individual

TABLE 2.1
SOIL and SOIL GAS ANALYTICAL RESULTS
IRP Site 3: Fire Protection Training Area No. 1
Beale AFB, California

| ANALYTE | UNITS | SAMPLE LOCATION - DEPTH (well number and feet below ground surface) | | |
|--|-------------------------------|--|---------------|----------------|
| Soil Hydrocarbons: | | VW-10 | VMP1-9 | VMP2-9 |
| TRPH | (mg/Kg) | 25,000 | 7,400 | 9,800 |
| Benzene | (mg/Kg) | 3.2 | ND | ND |
| Toluene | (mg/Kg) | 8.2 | 3.1 | 3.1 |
| Ethylbenzene | (mg/Kg) | 8.2 | 1.7 | ND |
| Xylenes | (mg/Kg) | 38 | 5.8 | 7.8 |
| Soil Inorganics: | | VW-10 | VMP1-9 | VMP2-9 |
| Iron | (mg/Kg dry wt.) | 19,700 | 35,300 | 27,600 |
| Alkalinity | (mg/Kg as CaCO ₃) | ND | 150 | 85 |
| pH | (units) | 7.4 | 8 | 7.8 |
| TKN | (mg/Kg dry wt.) | 83 | 160 | 72 |
| Phosphates | (mg/Kg dry wt.) | 320 | 500 | 380 |
| Soil Physical Parameters: | | VW-10 | VMP1-9 | VMP2-9 |
| Moisture | (% wt.) | 21.8 | 27.3 | 22.2 |
| Gravel | (% wt.) | 0 | 0 | 0 |
| Sand | (% wt.) | 50 | 54 | 41 |
| Silt | (% wt.) | 42.5 | 40 | 42 |
| Clay | (% wt.) | 7.5 | 6 | 17 |
| Soil Gas Hydrocarbons: | | VW | VMP1-8 | VMP3-14 |
| TVH | (ppmv) | 4,000 | 4,800 | 150 |
| Benzene | (ppmv) | 3.1 | 3.8 | 0.054 |
| Toluene | (ppmv) | 2.2 | 3.6 | 0.016 |
| Ethylbenzene | (ppmv) | 1.4 | 0.72 | ND |
| Xylenes | (ppmv) | 3.4 | 3.6 | 0.002 |
| Soil Gas Hydrocarbons (at surface): | | BKT-1 | BKT-2 | |
| TVH | (ppmv) | 0.87 | 0.75 | |
| Benzene | (ppmv) | ND | ND | |
| Toluene | (ppmv) | ND | ND | |
| Ethylbenzene | (ppmv) | ND | ND | |
| Xylenes | (ppmv) | ND | ND | |

NOTES:

| | |
|---|---------------------------------------|
| TRPH - Total recoverable petroleum hydrocarbons | CaCO ₃ - Calcium carbonate |
| TVH - Total volatile hydrocarbons | mg/Kg - milligrams per kilogram |
| TKN - Total Kjeldahl nitrogen | ND - Not detected |
| ppmv - Parts per million, volume per volume | NA - Not Analyzed |

casings of at least one volume of air. The soil-gas samples were shipped via Federal Express to Air Toxics, Ltd. in Rancho Cordova, California for analysis of total volatile hydrocarbons (TVH) and BTEX. The results of these analyses are summarized in Table 2.1.

Additional soil-gas samples were collected during the air permeability test for laboratory analysis to determine potential emissions of TVH and BTEX to the atmosphere resulting from air injection during the pilot test (described in detail in Section 3.1.5 of this report). This additional sampling was at the request of the Feather River Air Quality Management District. Two samples were collected at a surface location 15 feet to the northwest of VW-1; one sample was collected 2 hours after the start of air injection (sample BKT-1) and one sample 4 hours after the start of air injection (sample BKT-2) during the air permeability test. These "bucket" or flux-chamber samples were collected in Summa[®] cannisters. The results of these analyses showed no detectable BTEX hydrocarbon gases and low TVH concentrations (Table 2.1).

2.1.4 Field QA/QC Results

No QA/QC soil samples (field duplicates) were collected during sampling activities at the test site.

2.1.5 Exceptions to Test Protocol Document Procedures

Procedures described in the protocol document (Hinchee et al., 1992) related to soil and soil-gas sampling were used with the following exceptions:

- Soil samples were screened in the field (OVA readings) using both a THVA and a PID in order to compare data from both devices.
- Surface soil-gas samples during the air permeability test were collected at the request of the Feather River Air Quality Management District. These samples were analyzed for TVH and BTEX.

2.2 Bulk Fuel Storage Area (Site 18)

2.2.1 Soil Sample Field Analysis

Contaminated soils were identified based on field observations such as visual appearance, odor, and OVA readings. OVA readings were monitored using a photoionization detector (PID) on all soil samples in order to estimate the relative amount and extent of soil contamination detectable by such a device.

The extent of hydrocarbon contamination at the test site remains unknown. All boreholes drilled at the site encountered observable soil contamination. Some soils had a blue-green discoloration and a fuel-like odor. The discoloration was limited to the upper 30 feet and was sporadic. The odor was only noted within the upper 20 feet and varied in intensity. These visual and sensory observations correlate with OVA readings only in the respect that the highest OVA readings were recorded in the shallow sand zone at around 10 feet bgs; this sand was discolored in part and had a noticeable fuel odor. However, significant OVA readings persisted with depth, with a reading of 1165 ppmv at 55 feet bgs in VMP-3 (see Table 1.3 and Figure 1.7); the silty clays at this depth exhibited no discoloration and had no noticeable odor. Considering the lack of discoloration of soil and hydrocarbon odor, and the laboratory results, the high OVA readings at depth are

attributable to natural organic decomposition of material in the soil at depth rather than hydrocarbon contamination.

2.2.2 Soil Sample Laboratory Analysis

Soil samples for laboratory analysis were collected by using a hammer-driven split-spoon sampler lined with brass sleeves. The samples were preserved in the brass sleeves and capped with Teflon tape and plastic end-caps. Selection of soil samples for laboratory analysis was based on field OVA analysis. Samples from VW-1, VMP-1, VMP-2, and VMP-3 boreholes with the highest OVA readings were selected for laboratory analysis and were collected from depths of 11 to 12 feet bgs (see Table 1.3). An additional soil sample collected from the VMP-3 borehole at 55 feet bgs was submitted for analysis in order to evaluate the high OVA readings at deeper depths.

The selected soil samples were hand delivered to the ES-Berkeley Laboratory (ESBL) for chemical and physical analysis. Analytes for the VW-1, VMP-1, and VMP-2 soil samples were: total recoverable petroleum hydrocarbons (TRPH); benzene, toluene, ethylbenzene, and total xylenes (BTEX); iron; alkalinity; pH; total Kjeldahl nitrogen; phosphates; moisture; and grain size distribution. Analytes for the VMP-3 soil sample (the additional sample as noted above) were only TRPH, BTEX, and moisture. Samples to be analyzed for total Kjeldahl nitrogen, phosphates, and grain size distribution were transferred to Sequoia Analytical in Redwood City, California. The results of all analyses are summarized in Table 2.2. The TRPH concentrations are also included on the geological cross section (Figure 1.7).

2.2.3 Soil-Gas Sample Laboratory Analysis

Subsurface soil-gas samples were collected for laboratory analysis in Summa[®] cannisters. These samples were collected from the Vent Well (VW-1), and the screens at 6 feet bgs in two VMPs (VMP-1 and VMP-3) after purging the individual VMP casings of at least one volume of air. The soil-gas samples were shipped via Federal Express to Air Toxics, Ltd. in Rancho Cordova, California for analysis of total volatile hydrocarbons (TVH) and BTEX. The results of these analyses are summarized in Table 2.2.

2.2.4 Field QA/QC Results

No QA/QC soil samples (field duplicates) were collected during sampling activities at the test site.

2.2.5 Exceptions to Test Protocol Document Procedures

Procedures described in the protocol document (Hinchee et al., 1992) related to soil and soil-gas sampling were used with the following exceptions:

- Soil samples were screened in the field (OVA analysis) by using a PID instead of a THVA due to malfunction of the THVA available to field personnel at the time of boring operations.
- An extra soil sample (from 55 feet bgs in VMP-3 borehole) was submitted for laboratory analysis for TRPH, BTEX, and moisture in order to evaluate the high OVA readings at depths below that where contamination was observable by staining and odor.

TABLE 2.2
SOIL and SOIL GAS ANALYTICAL RESULTS
IRP Site 18: Bulk Fuel Storage Area
Beale AFB, California

| ANALYTE | UNITS | SAMPLE LOCATION - DEPTH (well number and feet below ground surface) | | | |
|----------------------------------|-------------------------------|--|----------------|----------------|----------------|
| Soil Hydrocarbons: | | VW-11 | VMP1-12 | VMP2-11 | VMP3-55 |
| TRPH | (mg/Kg) | 24,000 | 40,000 | 3,900 | 5 |
| Benzene | (mg/Kg) | ND | ND | ND | ND |
| Toluene | (mg/Kg) | 2.0 | 0.75 | 1.5 | ND |
| Ethylbenzene | (mg/Kg) | 6.7 | 0.52 | 2.7 | ND |
| Xylenes | (mg/Kg) | 16.0 | ND | 7.8 | ND |
| Soil Inorganics: | | VW-11 | VMP1-12 | VMP2-11 | VMP3-55 |
| Iron | (mg/Kg dry wt.) | 30,500 | 26,200 | 22,400 | NA |
| Alkalinity | (mg/Kg as CaCO ₃) | ND | 82 | 95 | NA |
| pH | (units) | 7.0 | 7.4 | 7.8 | NA |
| TKN | (mg/Kg dry wt.) | 69 | 46 | ND | NA |
| Phosphates | (mg/Kg dry wt.) | 300 | 300 | 140 | NA |
| Soil Physical Parameters: | | VW-11 | VMP1-12 | VMP2-11 | VMP3-55 |
| Moisture | (% wt.) | 24.8 | 26.9 | 26.5 | 13.1 |
| Gravel | (% wt.) | 0 | 0 | 0 | NA |
| Sand | (% wt.) | 69 | 67 | 61 | NA |
| Silt | (% wt.) | 23.5 | 25 | 32.5 | NA |
| Clay | (% wt.) | 7.5 | 8 | 6.5 | NA |
| Soil Gas Hydrocarbons: | | VW | VMP1-6 | VMP3-6 | |
| TVH | (ppmv) | 1,500 | 1,400 | 7,900 | |
| Benzene | (ppmv) | 2.0 | 1.1 | 31 | |
| Toluene | (ppmv) | 0.65 | 1.1 | 3.0 | |
| Ethylbenzene | (ppmv) | 2.1 | 1.2 | 2.7 | |
| Xylenes | (ppmv) | 2.3 | 2.4 | 0.76 | |

NOTES:

| | |
|---|---------------------------------------|
| TRPH - Total recoverable petroleum hydrocarbons | CaCO ₃ - Calcium carbonate |
| TVH - Total volatile hydrocarbons | mg/Kg - milligrams per kilogram |
| TKN - Total Kjeldahl nitrogen | ND - Not detected |
| ppmv - Parts per million, volume per volume | NA - Not Analyzed |

3.0 PILOT TEST RESULTS

3.1 Fire Protection Training Area No. 1 (Site 3)

3.1.1 Initial Soil Gas Chemistry

Prior to initiating any air injection, all VMPs were purged until oxygen levels had stabilized, and then initial oxygen and carbon dioxide concentrations were sampled using portable gas analyzers, as described in the technical protocol document (Hinchee et al., 1992). Except at VMP1-8, microorganisms had depleted soil gas oxygen supplies at all VMP screened intervals, indicating significant soil contamination. Useable initial soil gas samples could not be extracted from VMP1 and VMP3 at the 8-foot depth because water had migrated down into the monitoring point filter pack during construction. The background VMP (VMP-4), outside the area of soil contamination, had 20.7, 18.0, and 16.5 percent oxygen at depths of 8, 15, and 24 feet, respectively. The initial soil gas chemistry measured at IRP Site 3 shows significant contamination at 8 to 10 feet bgs as summarized in Table 3.1. TRPH data for soil samples are also provided to demonstrate the relationship between oxygen levels and the contaminated soils. No air samples were collected from VMP3-8 because this screened interval was flooded during VMP construction when a small water line was broken.

3.1.2 Air Permeability

An air permeability test was conducted according to protocol document procedures. Air was injected into the VW for 5.5 hours at a rate of approximately 35 scfm with an average pressure of approximately 4.2 pounds per square inch (psi) or 116 inches of water (in. H₂O). The pressure response and calculated permeability at each VMP screened interval are shown on Figures 3.1 through 3.3. Due to the slow response and relatively long time to achieve steady state, the HyperVentilate™ model was used to calculate air permeability (Hinchee et al., 1992). Calculated air permeability values ranged between 9 and 13 darcys. It is important to note that VMPs were screened at discrete intervals within both clay and silty-sand zones. Pressure influence and oxygen movement was apparent in all soil types. A radius of pressure influence of at least 55 feet was observed at the 14- and 24-foot depths and at least 30 feet at the 8-foot depth.

3.1.3 Oxygen Influence

The depth and radius of oxygen increase in the subsurface resulting from air injection into the central VW during pilot testing is the primary design parameter for full-scale bioventing systems. Optimization of full-scale and multiple VW systems requires pilot testing to determine the volume of soil that can be oxygenated at a given flow rate and VW screen configuration.

Table 3.2 presents the change in soil gas oxygen levels that occurred during the 5.5-hour air permeability test at IRP Site 3. This relatively brief air injection period at 35 scfm produced changes in soil gas oxygen levels at most VMP screened intervals except for VMP3-14 and VMP3-24 where little or no change was measured. At some points oxygen levels appeared to decrease as oxygen depleted soil gas was displaced outwardly from the center of the contaminated soil volume. Based on measured pressure response, which is an indicator of long-term oxygen transport, and changes in oxygen levels, it is

TABLE 3.1
INITIAL SOIL GAS CHEMISTRY
IRP SITE 3
BEALE AFB, CALIFORNIA

| Sample Location | Depth (ft) | O ₂ (%) | CO ₂ (%) | TVH (ppmv) | TRPH (mg/kg) in soil |
|-----------------|------------|--------------------|---------------------|------------|----------------------|
| VMP1 | 8 | NS | NS | 4,800 | 7,400 |
| VMP1 | 14 | 0.1 | 13.0 | NS | NS |
| VMP1 | 24 | 1.5 | 11.8 | NS | NS |
| VMP2 | 8 | 3.0 | 5.5 | NS | 9,800 |
| VMP2 | 14 | 0.2 | 12.5 | NS | NS |
| VMP2 | 24 | 7.0 | 9.0 | NS | NS |
| VMP3 | 8 | NS | NS | NS | NS |
| VMP3 | 14 | 4.5 | 10.5 | 150 | NS |
| VMP3 | 24 | 10.0 | 8.0 | NS | NS |
| VMP 4 | 8 | 20.7 | 0.5 | NS | NS |
| VMP 4 | 15 | 18.0 | 1.2 | NS | NS |
| VMP 4 | 24 | 16.5 | 0.8 | NS | NS |
| VW | 10-25 | 1.2 | 12.5 | 4,000 | 25,000* |

TVH = Total Volatile Hydrocarbons, in parts per million, volume per volume (ppmv). Laboratory results (see Table 2.1).

TRPH = Total recoverable petroleum hydrocarbons, in milligrams per kilogram (mg/kg). Laboratory results of soil samples (see Table 2.1).

* Sample collected at a depth of 10 feet.

NS = Not Sampled.

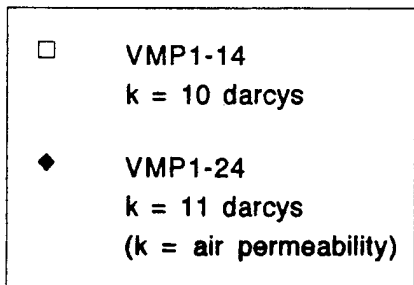
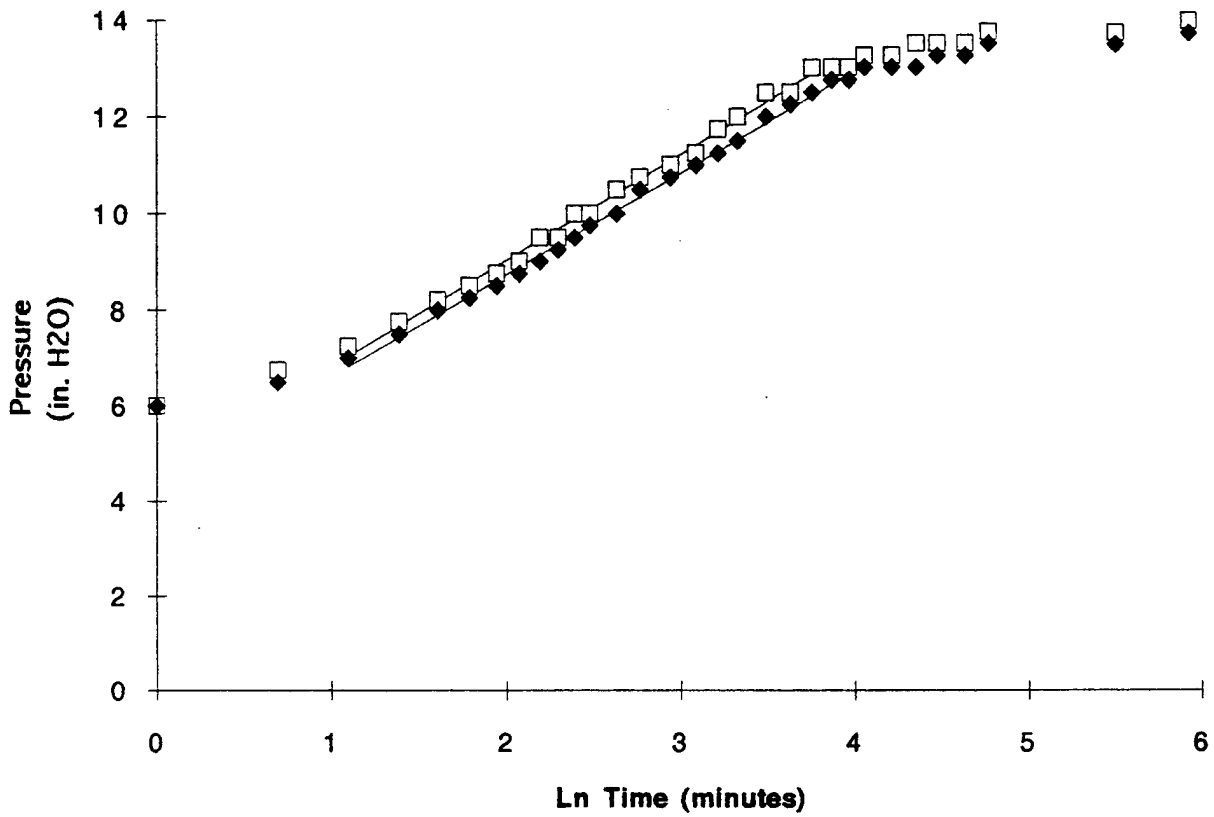

Figure 3.1
 Air Permeability Test
 Monitoring Point VMP1: r = 15 feet
 IRP Site 3
 Beale AFB, California

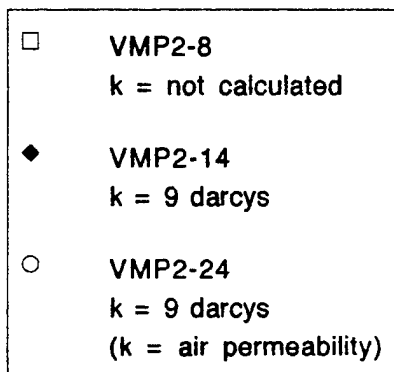
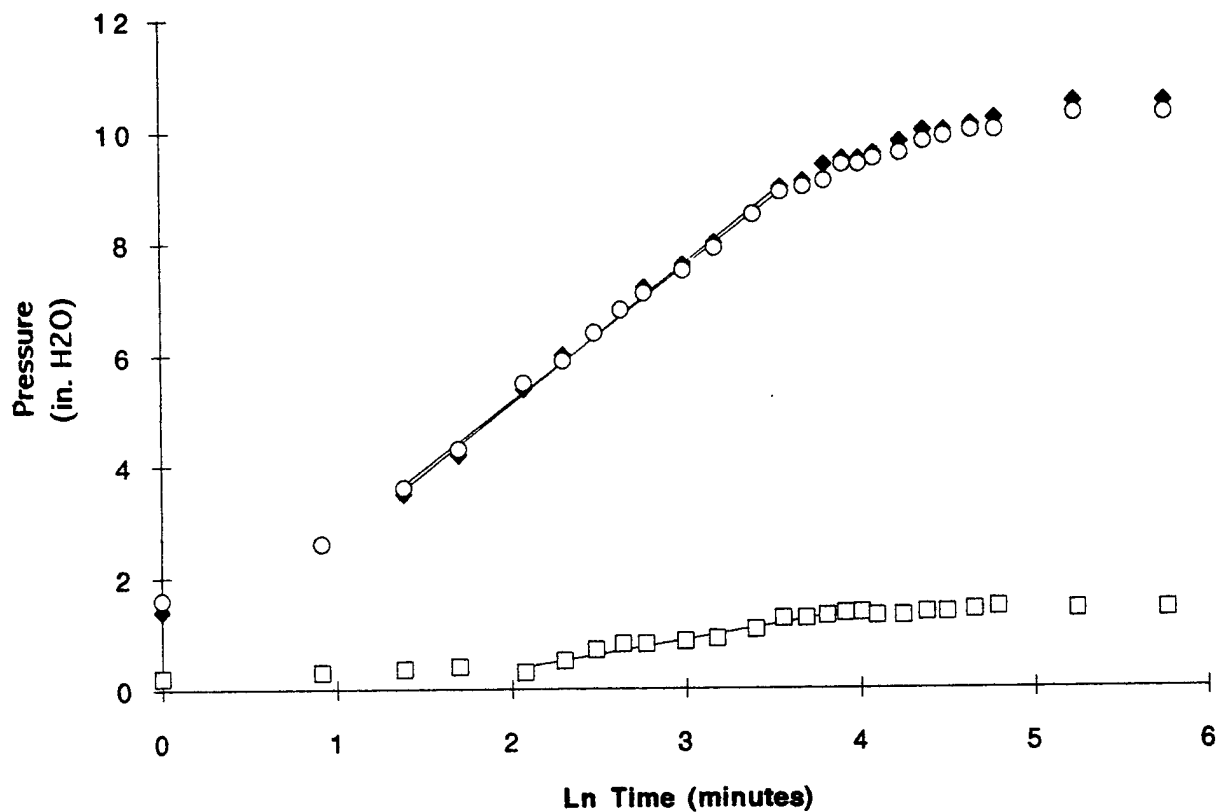

Figure 3.2
 Air Permeability Test
 Monitoring Point VMP2: r = 30 feet
 IRP Site 3
 Beale AFB, California

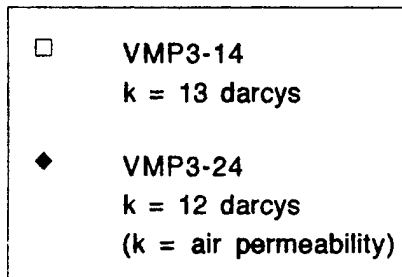
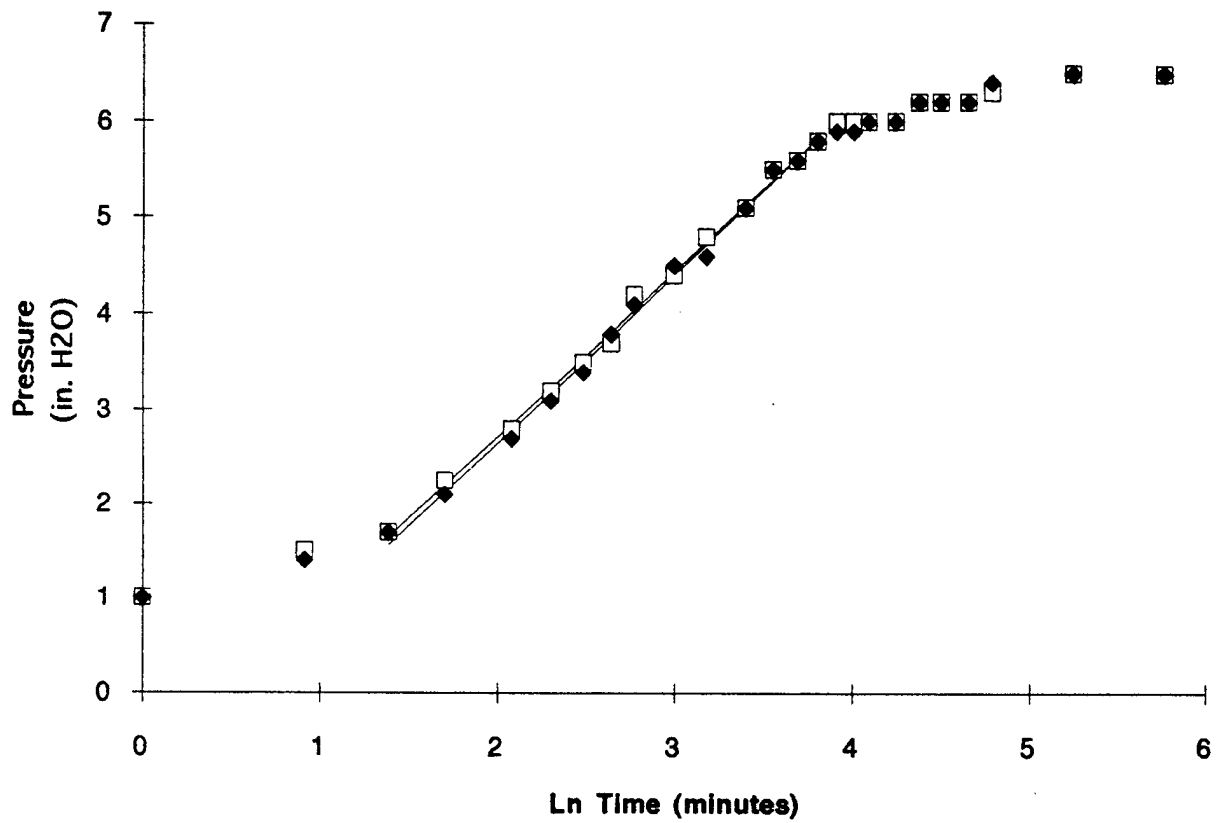

Figure 3.3
 Air Permeability Test
 Monitoring Point VMP3: r = 55 feet
 IRP Site 3
 Beale AFB, California

TABLE 3.2
INFLUENCE OF AIR INJECTION AT VENT WELL
ON MONITORING POINT OXYGEN LEVELS
IRP SITE 3
BEALE AFB, CALIFORNIA

| Sample Location | Distance From VW (ft) | Depth(ft) | Initial O ₂ (%) | Final O ₂ (%) |
|-----------------|-----------------------|-----------|----------------------------|--------------------------|
| VMP1 | 15 | 8 | NS | 2.5 |
| VMP1 | 15 | 14 | 0.1 | 17.5 |
| VMP1 | 15 | 24 | 1.5 | 17.5 |
| VMP2 | 30 | 8 | 3.0 | 1.0 |
| VMP2 | 30 | 14 | 0.2 | 1.5 |
| VMP2 | 30 | 24 | 7.0 | 10.0 |
| VMP3 | 55 | 8 | NS | NS |
| VMP3 | 55 | 14 | 4.5 | 4.0 |
| VMP3 | 55 | 24 | 10.0 | 10.0 |

NS = Not Sampled

anticipated that the radius of oxygen influence for a long-term bioventing system at this site will exceed 55 feet at all depths. Monitoring during the extended pilot test at this site will better define the effective treatment radius.

3.1.4 *In Situ* Respiration Rates

The *in situ* respiration test was performed by injecting 1 cfm of air (20.8 percent oxygen) into three VMP screened intervals (VMP1-14, VMP1-24, and VMP2-14) for a 23-hour period, and into the VW for 5.5 hours (during the air permeability test). Oxygen loss and other changes in soil gas composition over time were then determined. Oxygen, TVH, and carbon dioxide were measured following air injection for a period of 53 hours at the VMPs, and 64 hours at the VW. Oxygen utilization rates were then used to calculate the biodegradation rates. The results of *in situ* respiration testing at this site are presented in Figures 3.4 through 3.7. Table 3.3 provides a summary of the observed oxygen utilization rates.

A 5-percent mixture of helium in air was injected into the VMP1-14 screened interval, and helium was measured for 53 hours following air injection. Because helium is a conservative, inert gas, the change in helium concentrations over time can be useful in determining the effectiveness of the bentonite seals between VMP screened intervals and whether diffusion is responsible for a portion of the oxygen lost from each VMP. Figure 3.8 compares oxygen utilization and helium retention at VMP1-14. During the respiration test, helium loss at VMP1-14 resulted in a fractional loss of approximately 47 percent of the initial helium concentration. This helium loss is considered acceptable because helium will diffuse approximately three times faster than oxygen, due to oxygen's greater molecular weight. This means that most of the observed oxygen loss is the result of bacterial respiration and not due to diffusion or faulty VMP construction.

Results from this test indicate that VMP1-14, VMP2-14, and the VW had significant soil hydrocarbon contamination. These VMP screened intervals and the VW had initial oxygen concentrations of less than 1.5 percent, and a soil sample from the VW at a depth of 10 feet had a TRPH concentration of 25,000 mg/kg. Oxygen loss at these VMP intervals and the VW occurred at moderate rates of 0.0032, 0.0040, and 0.0018 percent per minute at VMP1-14, VMP2-14, and the VW, respectively. The lower rate measured at the VW is probably the result of effectively averaging the rates for soils with varying levels of contamination because of the longer screened interval. Air injected at VMP1 during the respiration test may have affected the results observed at the VW by introducing oxygenated air and thereby lowering the apparent oxygen-loss rate. The contamination appears to be much less at VMP1-24, as indicated by the low oxygen loss rate (0.0005 percent per minute) and the slow buildup of TVH in the soil gas from this screened interval.

Based on oxygen utilization rates measured at VMP1-14 and VMP2-14, an estimated 170 to 210 milligrams (mg) of fuel per kilogram (kg) of soil can be degraded each year at this site. This conservative estimate is based on an average air-filled porosity of 0.026 liter of air per kg of soil, and a ratio of 3.5 mg of oxygen consumed for every 1 mg of fuel biodegraded. Actual rates may exceed these estimates. Methods of calculation followed the technical protocol document (Hinchee et al., 1992).

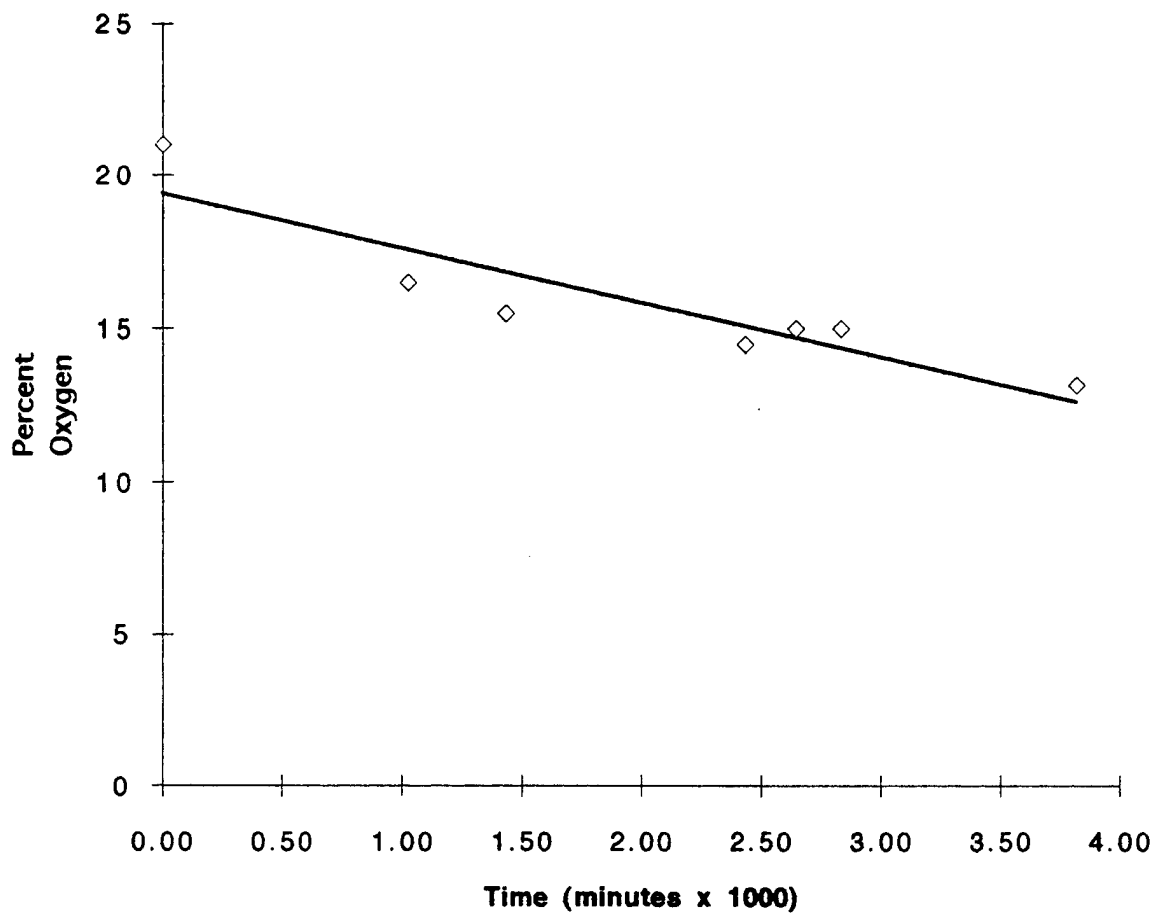

◇ Percent Oxygen
 — $k = 0.002$ %/min.
 (oxygen utilization rate)

25,000 mg/kg TRPH
 (soil analysis result for this location)

Figure 3.4
 Respiration Test
 IRP Site 3 : Vent Well
 Beale AFB, CA

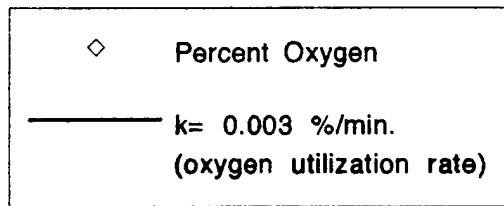
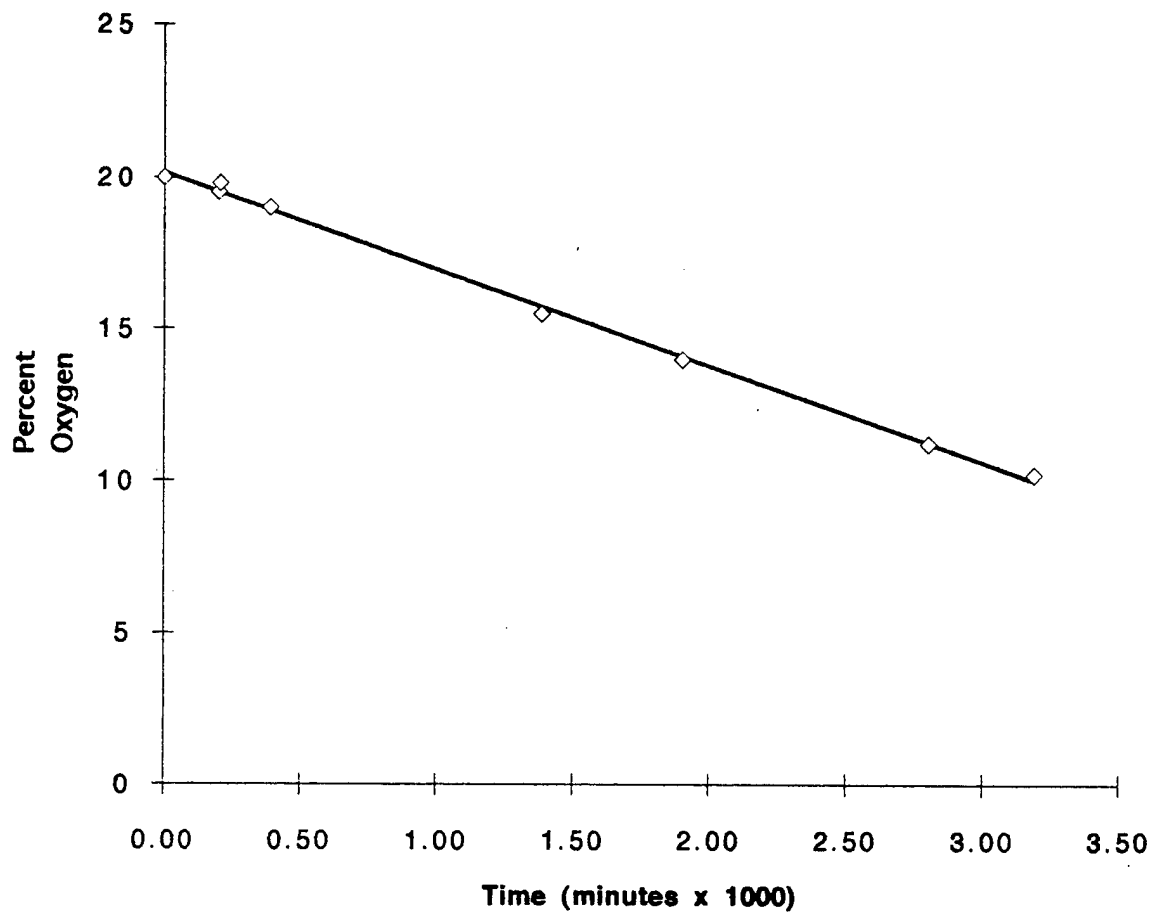
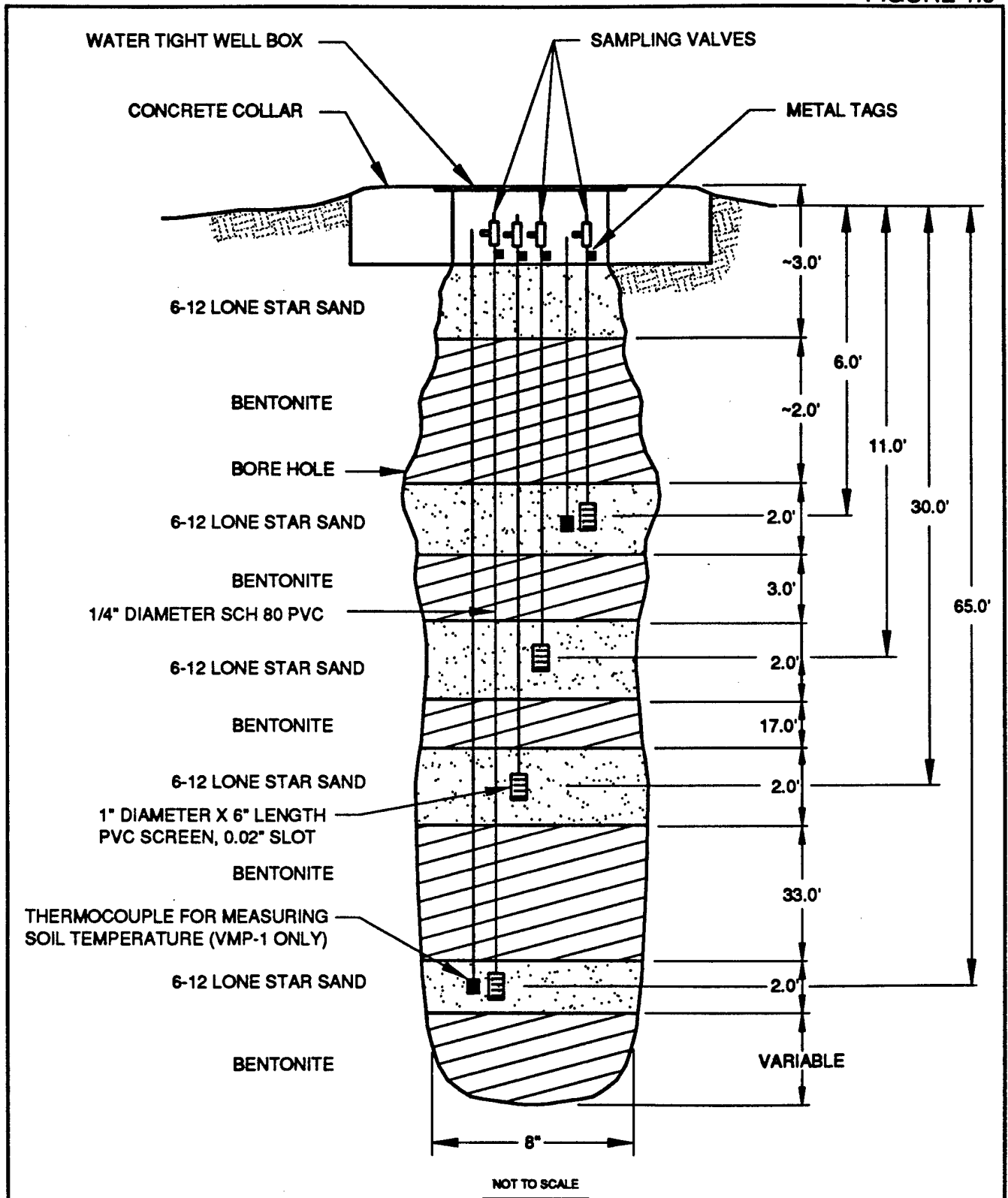

Figure 3.5
Respiration Test
IRP Site 3 : Monitoring Point VMP1-14
Beale AFB, CA

FIGURE 1.9



NOTE: SEE TABLE 1.4 FOR DETAILS

**AS-BUILT VAPOR MONITORING
POINT CONSTRUCTION DETAIL**

**IRP SITE 18
BULK FUEL STORAGE AREA**

**BEALE AIR FORCE BASE
CALIFORNIA**

ENGINEERING-SCIENCE, INC.

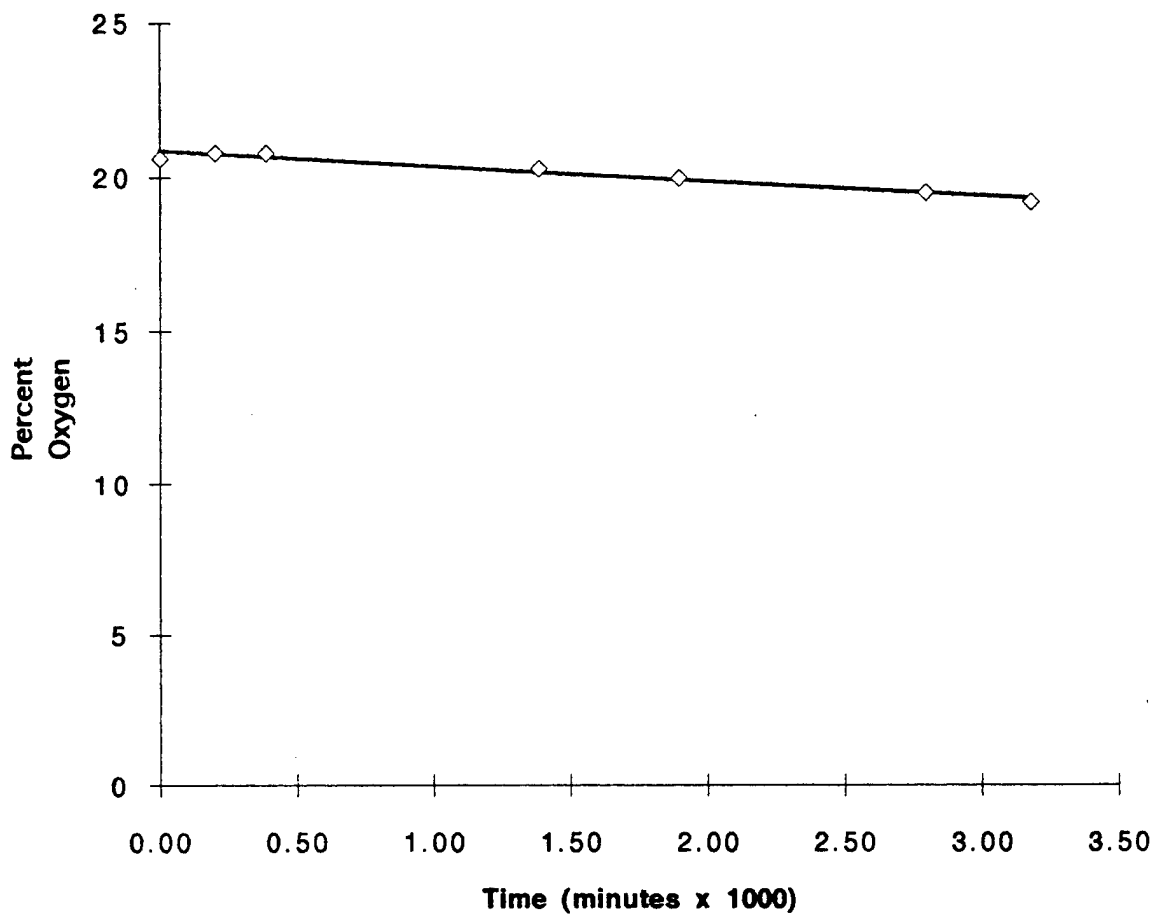

Figure 3.6
 Respiration Test
 IRP Site 3 : Monitoring Point VMP1-24
 Beale AFB, CA

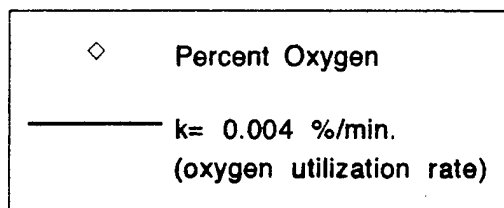
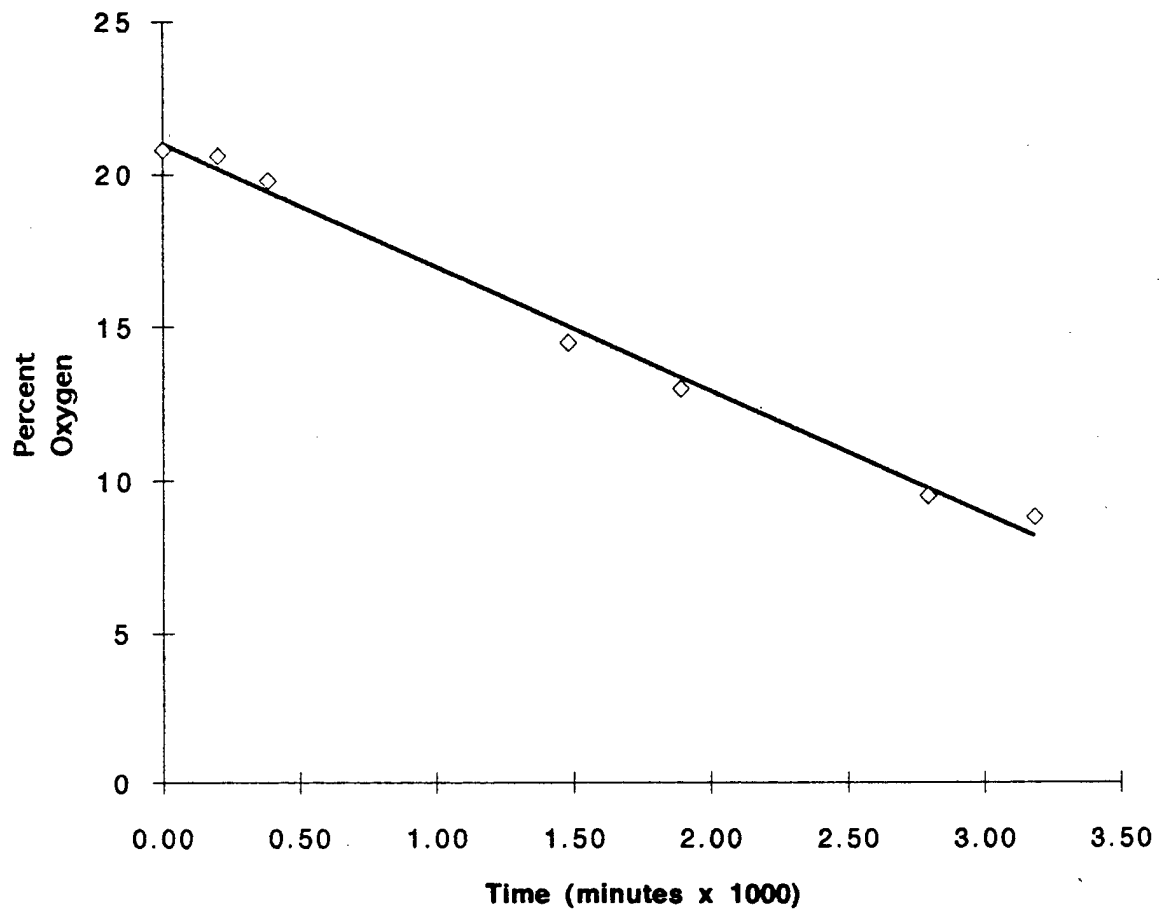

Figure 3.7
Respiration Test
IRP Site 3 : Monitoring Point VMP2-14
Beale AFB, CA

TABLE 3.3
OXYGEN UTILIZATION RATES
IRP SITE 3
BEALE AFB, CALIFORNIA

| Sample Location | Depth (ft) | Test Duration (min) | Initial O ₂ (%) | Final O ₂ (%) | O ₂ Utilization Rate (%/minute) |
|-----------------|------------|---------------------|----------------------------|--------------------------|--|
| VMP1 | 14 | 3,190 | 20.0 | 10.2 | 0.0032 |
| VMP1 | 24 | 3,180 | 20.6 | 19.2 | 0.00048 |
| VMP2 | 14 | 3,180 | 20.8 | 8.8 | 0.0040 |
| VW | 10-25 | 3,820 | 21.0 | 13.2 | 0.0018 |

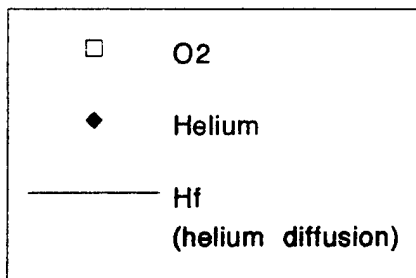
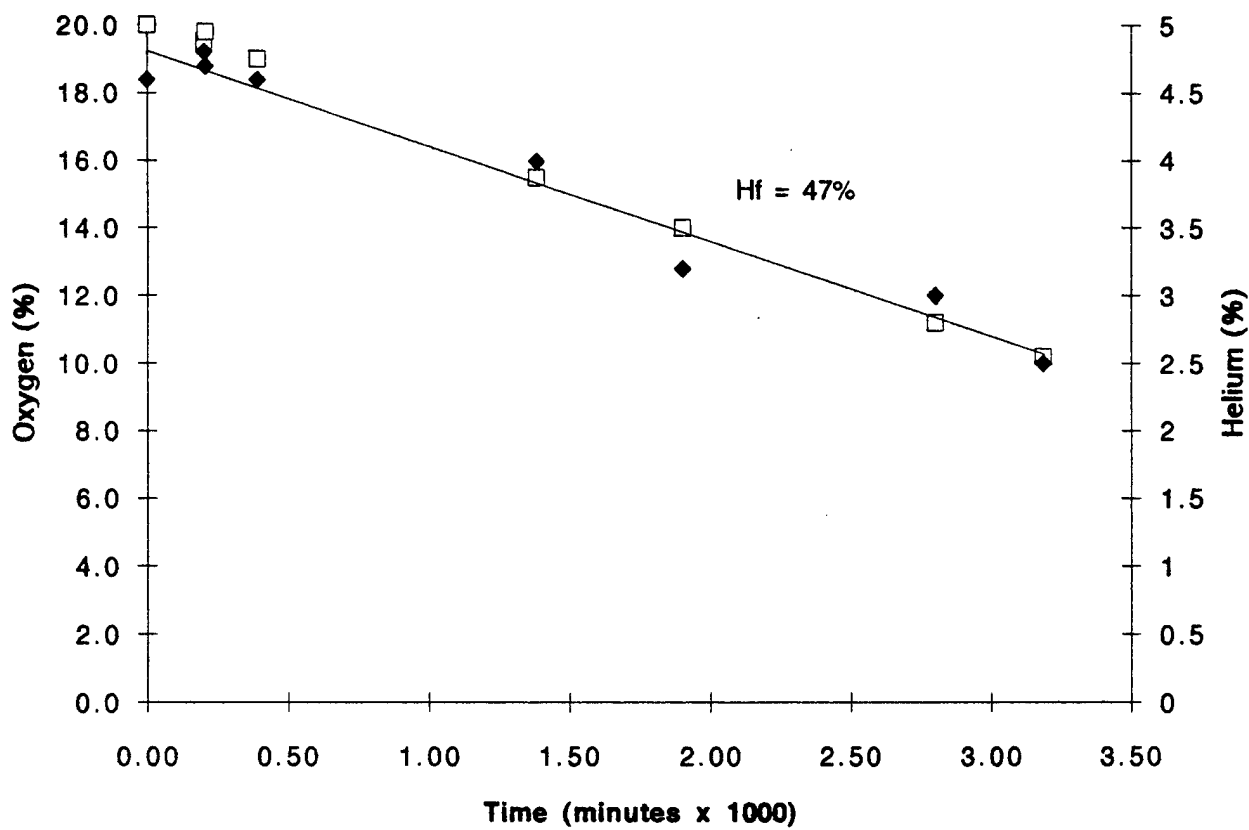

Figure 3.8
 Respiration Test
 Oxygen and Helium Concentrations
 Monitoring Point VMP1-14
 IRP Site 3
 Beale AFB, California

This biodegradation rate is expected to increase as continued air injection increases the air-filled porosity. Additional respiration testing at 6 months, and respiration testing and soil sampling one year following the initial pilot test will better define the long-term biodegradation rates. Table 3.4 is a summary of data from the initial pilot test at IRP Site 3.

3.1.5 Potential Air Emissions

Air emission measurements were taken at IRP Site 3 before and during the pilot test. The results indicate that very low levels of TVH and no detectable BTEX emissions occurred as a result of subsurface air injection during the bioventing pilot test (see Table 2.1). The long-term potential for air emissions from the pilot test is even lower, as the initial 6 hours of air injection probably displaced the highest concentrations of volatile organics from the soil.

TVH were measured at the ground surface before and during air injection at nine locations. The measurement locations were arranged around the injection well radiating outward from the injection well in three arms of three points each, spaced roughly 120 degrees apart. The points in each arm were spaced at 15, 30, and 45 feet from the injection well. Hydrocarbon emissions were measured using both field and laboratory analysis. TVH measurements were taken by placing a simple flux chamber (an inverted 5-gallon plastic bucket, fitted with a hose barb) on the ground surface and then withdrawing gas samples at a rate of 1 liter per minute into a total volatile hydrocarbons analyzer. This platinum catalyst combustion detector is not specific for fuel hydrocarbons and will also detect low levels of other soil gases, such as methane, which are common at old, fuel-contaminated sites. The air in the flux chamber was sampled continuously for a period of 5 minutes at each location, and the highest reading was recorded in the field book.

In order to determine the fuel hydrocarbon and BTEX content of the soil gas emissions, two samples were collected from a monitoring location 15 feet from the VW after 4 and 6 hours of air injection. These samples were collected for laboratory analyses by using an evacuated, 1-liter Summa® canister to draw a sample from the flux chamber. Samples were sent to Air Toxics, Inc. in Rancho Cordova, California for BTEX and total volatile petroleum hydrocarbon analysis using EPA Method TO-3.

Based on laboratory analysis, it appears that the vast majority of the hydrocarbons emitted during the initial pilot tests were non-fuel hydrocarbons such as methane. No BTEX was detected in the laboratory sample, and less than 1 ppmv (4 g/L) of fuel hydrocarbon was detected. Air was injected at a rate of approximately 30 scfm, and this flow rate will be continued throughout the extended pilot test. Even if fuel hydrocarbon emissions did not decrease over time and the entire 30 scfm of displaced soil gas was discharged into the atmosphere, the total emission from the site would be less than 5 grams per day.

It is anticipated that long-term emissions at this pilot test site will be negligible as accumulated hydrocarbon vapors in the soil will move slowly outward from the air injection point and will be biodegraded as they move horizontally through the soil. The potential for vertical soil vapor flow, and the resulting discharge to the atmosphere, is low because the layered structure of the unconsolidated deposits underlying this site

Table 3.4
PILOT TEST DATA SUMMARY
IRP Site 3: Fire Protection Training Area No.1
Beale AFB, California

| WELL No.-DEPTH | Soil Data | | Air Permeability Test | | | | In Situ Respiration Test | | | | Calculated Biodegradation Rate K _b (mg/kg fuel per year) | | |
|----------------|-----------|------------|-----------------------|----------------|-----------|-------|--------------------------|--------------------------|---|-------------|---|--------------|--------------|
| | Soil Type | Soil Anal. | Initial Soil Gas | Final Soil Gas | Air Perm. | TRPH | Init. O ₂ (%) | Final O ₂ (%) | O ₂ Util. Rate (k ₀) | He Init (%) | | He Final (%) | He Diff. (%) |
| VMP1-8 | sly CLAY | 7,400 | 0.1 | 13.0 | 10 | 4,800 | 2.5 | 20.0 | 10.2 | 0.19 | 4.5 | 2.5 | 170 |
| VMP1-14 | sly SAND | | 1.5 | 11.8 | 11 | | | 20.6 | 19.2 | 0.03 | | | |
| VMP1-24 | CLAY | | 3.0 | 5.5 | 1.0 | | | 20.8 | 8.8 | 0.24 | | | 210 |
| VMP2-8 | sly CLAY | 9,800 | 0.2 | 12.5 | 9 | | | | | | | | |
| VMP2-14 | cl SAND | | 7.0 | 9.0 | 10.0 | | | | | | | | |
| VMP2-24 | sly CLAY | | 4.5 | 10.5 | 13 | | | | | | | | |
| VMP3-8 | sly CLAY | | 10.0 | 8.0 | 12 | | | | | | | | |
| VMP3-14 | sly SAND | | 20.7 | 0.5 | | | | | | | | | |
| VMP3-24 | sly CLAY | | 18.0 | 1.2 | | | | | | | | | |
| VMP4-8 | sly CLAY | | 16.5 | 0.8 | | | | | | | | | |
| VMP4-15 | sly SAND | | 1.2 | 12.5 | 4,000 | | | | | | | | |
| VMP4-24 | sly CLAY | | 1.2 | 12.5 | 4,000 | | | 21.0 | 13.2 | 0.11 | | | |
| VW1-(10 - 25) | | 25,000 | | | | | | | | | | | |

NOTES:

- Sample was not taken/analyzed.

TRPH - Total Recoverable Petroleum Hydrocarbons (laboratory results)

TVH - Total Volatile Hydrocarbons (laboratory results)

VW1 Soil sample collected from 10 ft. bgs.

Air Permeability Test conducted for 5.5 hrs; injection at 35 scfm (avg. press.= 4.2psi).

Air Permeability calculation by HyperVentilate computer program.

Final O₂ readings for the Air Permeability Test taken at the end of the 5.5hr injection period.

In Situ Respiration Test: injection at 1cfm for 23hrs; O₂/CO₂/TVH/He measurements in VMPs taken for 53hrs following injection;

O₂/CO₂/TVH measurements in VW taken for 64hrs following injection.

Oxygen Utilization Rate calculation by HyperVentilate computer program.

Helium Diffusion is percent fractional loss of He following injection.

Biodegradation Rate calculation by the HyperVentilate computer program. Assumptions used:

* Avg. air-filled porosity of 0.026 liter of air per kg of soil.

* Ratio of 3.5mg O₂ consumed per 1mg fuel biodegraded.

mg/kg - Milligrams per kilogram (parts per million - ppm)

ppmv - Parts per million, volume per volume

favors horizontal air flow over vertical flow. The relatively impermeable clay soil near the ground surface also inhibits flow to the atmosphere.

3.1.6 Recommendations

Initial bioventing tests at this site indicate that oxygen has been depleted in the contaminated soils, and that air injection is an effective method of increasing aerobic biodegradation of fuel. The Air Force Center for Environmental Excellence (AFCEE) has recommended that air injection continue at this site to determine the long-term radius of oxygen influence and the effect of time, available nutrients, and changing temperatures on fuel biodegradation rates.

A small, 2.5-horsepower Gast™ regenerative blower has been installed at IRP Site 3 to continue a rate of air injection of approximately 30 scfm. In July 1993, ES personnel will return to the site to sample and analyze the soil gas and conduct a second respiration test. In January 1994, a final respiration test will be conducted, and soil and soil gas samples will be collected from the site to determine the degree of remediation achieved during the first year of *in situ* treatment.

Based on results presented by ES for the first year of pilot-scale bioventing, AFCEE will recommend one of two options:

1. Upgrade, if necessary, and continue operation of the bioventing system for full-scale remediation of the site. AFCEE can assist the base in obtaining regulatory approval for upgrading and continued operation.
2. If significant difficulties or poor results are encountered during bioventing at this site, AFCEE may recommend removal of the blower system and proper abandonment of the VW and VMPs.

3.2 Bulk Fuel Storage Area (Site 18)

3.2.1 Initial Soil Gas Chemistry

Prior to initiating any air injection, all VMPs at IRP Site 18 were purged until oxygen levels had stabilized, and then initial oxygen, carbon dioxide, and TVH concentrations were sampled using portable gas analyzers, as described in the technical protocol document (Hinchee et al., 1992). Microorganisms had depleted oxygen supplies at all four VMP screened intervals (typically 6, 11, 30, and 65 feet) and the VW, indicating soil contamination throughout the test area. Oxygen levels at or below 5 percent were measured at 9 screened intervals in highly contaminated soils. In contrast, the background VMP (VMP-4 installed at IRP Site 3), outside the area of soil contamination, had 20.7, 18.0, and 16.5 percent oxygen at depths of 8, 15, and 24 feet, respectively. The initial soil gas chemistry at IRP Site 18 is summarized in Table 3.4. TRPH data for soil samples are also provided to demonstrate the relationship between low oxygen levels and contaminated soils.

3.2.2 Air Permeability

An air permeability test was conducted according to protocol document procedures. Air was injected into the VW for 5.5 hours at a rate of approximately 38 scfm with an average pressure of approximately 3.0 psi (83 in. H₂O). The pressure response and calculated permeabilities at each VMP are presented on Figures 3.9 through 3.12. Due to

TABLE 3.5
INITIAL SOIL GAS CHEMISTRY
IRP SITE 18
BEALE AFB, CALIFORNIA

| Sample Location | Depth (ft) | O ₂ (%) | CO ₂ (%) | TVH (ppmv)* | TVH (ppmv)** | TRPH (mg/kg) in soil sample |
|-----------------|------------|--------------------|---------------------|-------------|--------------|-----------------------------|
| VMP1 | 6 | 1.5 | 9.5 | >10,000 | 1,400 | NS |
| VMP1 | 11 | 3.0 | 8.0 | >10,000 | NS | 40,000 |
| VMP1 | 30 | 2.5 | 3.0 | >10,000 | NS | NS |
| VMP1 | 65 | 5.5 | <0.5 | 4,800 | NS | NS |
| VMP2 | 6 | 10.0 | 6.0 | >10,000 | NS | NS |
| VMP2 | 11 | 2.0 | 9.0 | >10,000 | NS | 3,900 |
| VMP2 | 30 | 7.5 | 1.5 | 2,000 | NS | NS |
| VMP2 | 65 | 12.5 | 1.5 | 280 | NS | NS |
| VMP3 | 6 | 1.0 | 11.5 | >10,000 | 7,900 | NS |
| VMP3 | 11 | 1.0 | 9.0 | >10,000 | NS | NS |
| VMP3 | 30 | 5.0 | 3.5 | 2,200 | NS | NS |
| VMP3 | 55 | 2.0 | 6.0 | 540 | NS | 5 |
| VW | 10-60 | 0.5 | 9.5 | >10,000 | 1,500 | 24,000*** |

* TVH = Total Volatile Hydrocarbons in parts per million, volume per volume (ppmv). Values measured with instrument set at "full response". Field results.

** TVH (ppmv) = Laboratory results (see Table 2.2).

TRPH = Total Recoverable Petroleum Hydrocarbons, in milligrams per kilogram (mg/kg). Laboratory results of soil samples (see Table 2.2).

*** Sample collected at a depth of 12 feet.

NS = Not Sampled.

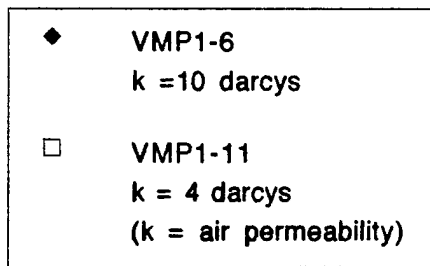
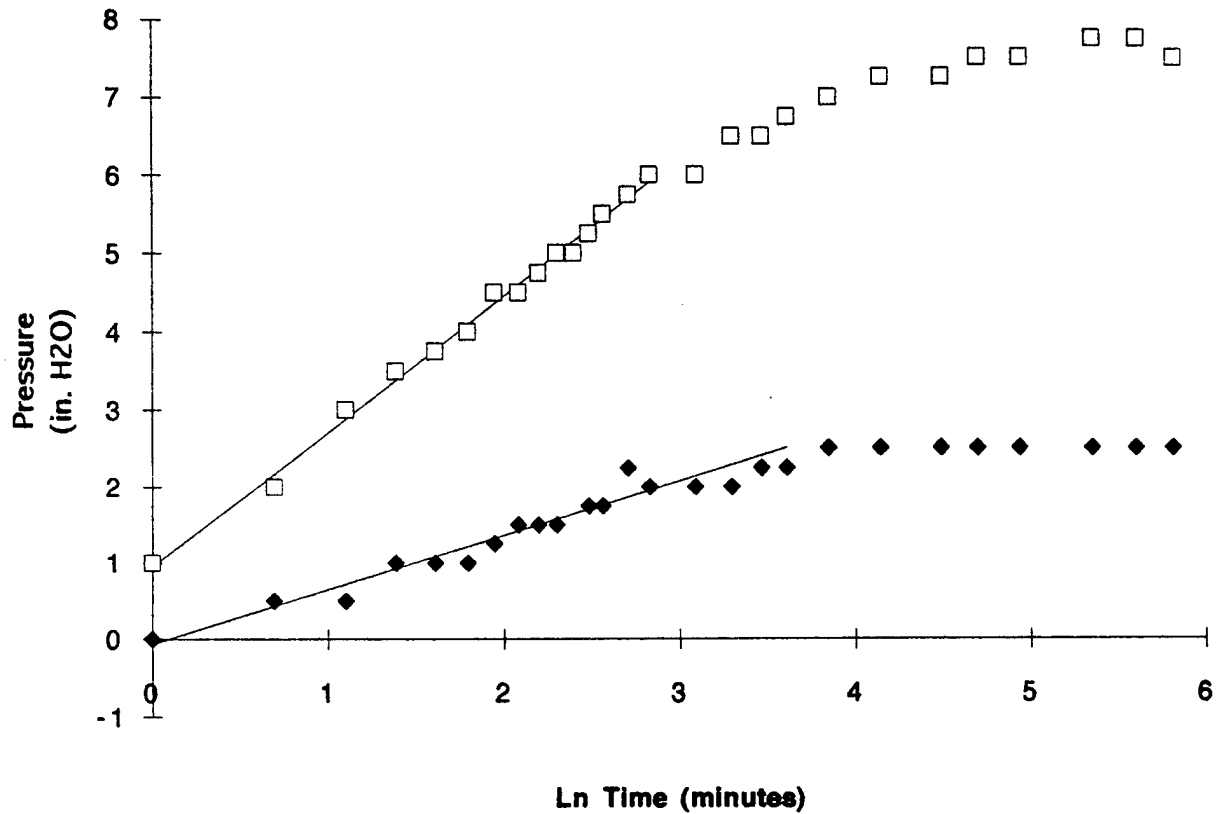

Figure 3.9
 Air Permeability Test
 Monitoring Points VMP1-6 and VMP1-11: r = 15 feet
 IRP Site 18
 Beale AFB, California

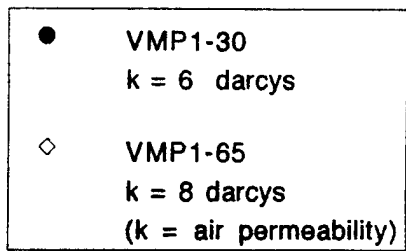
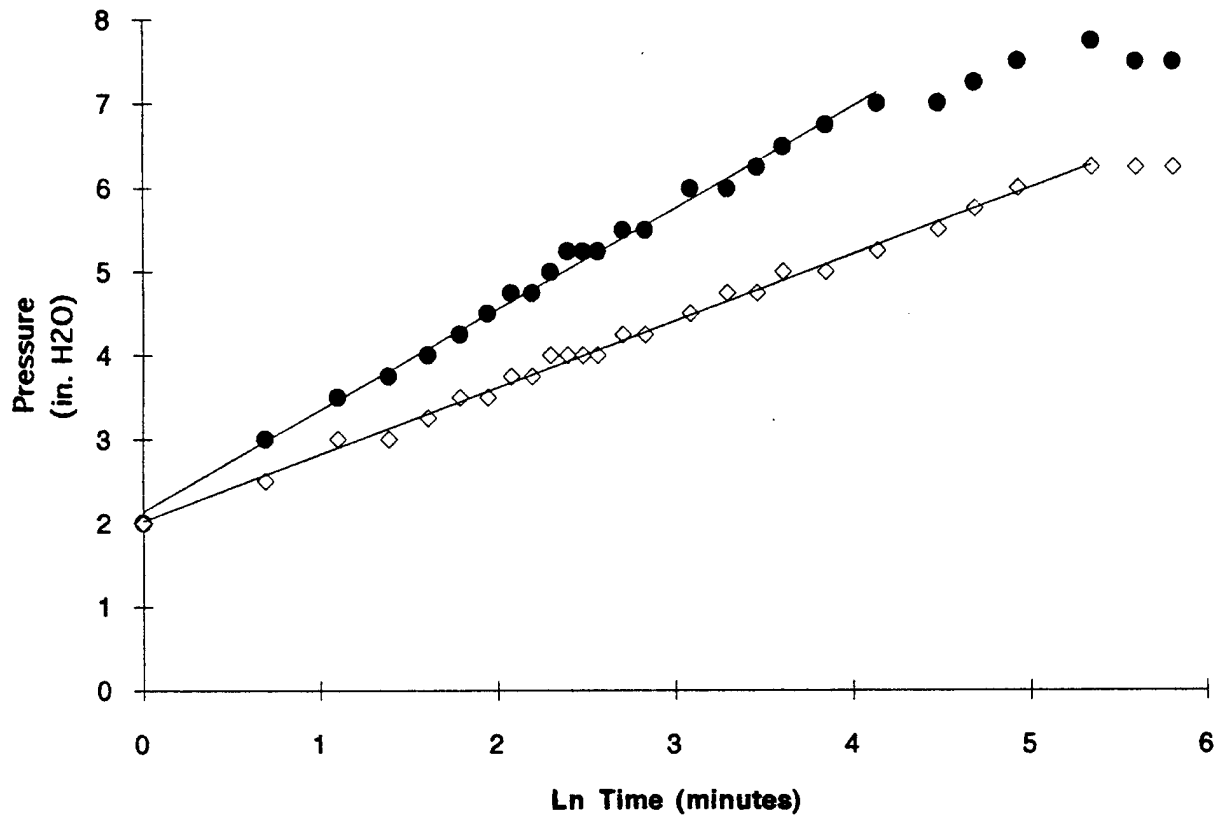
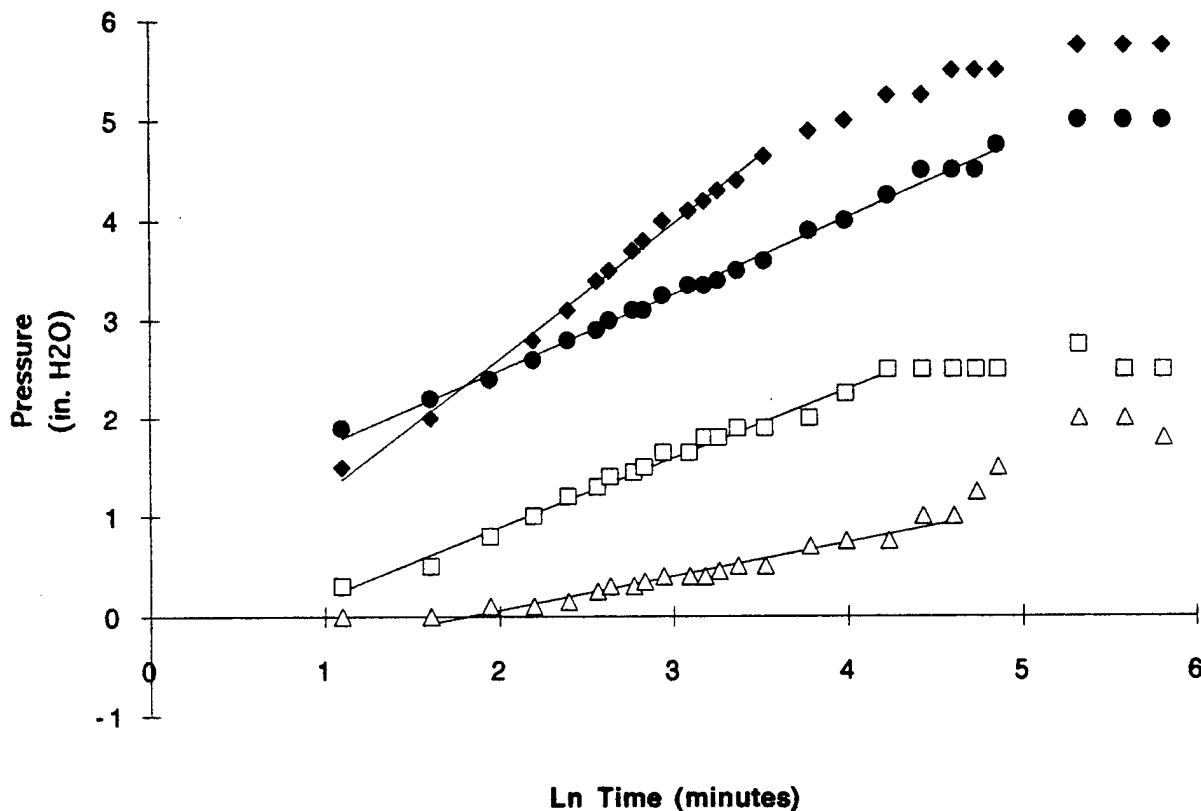
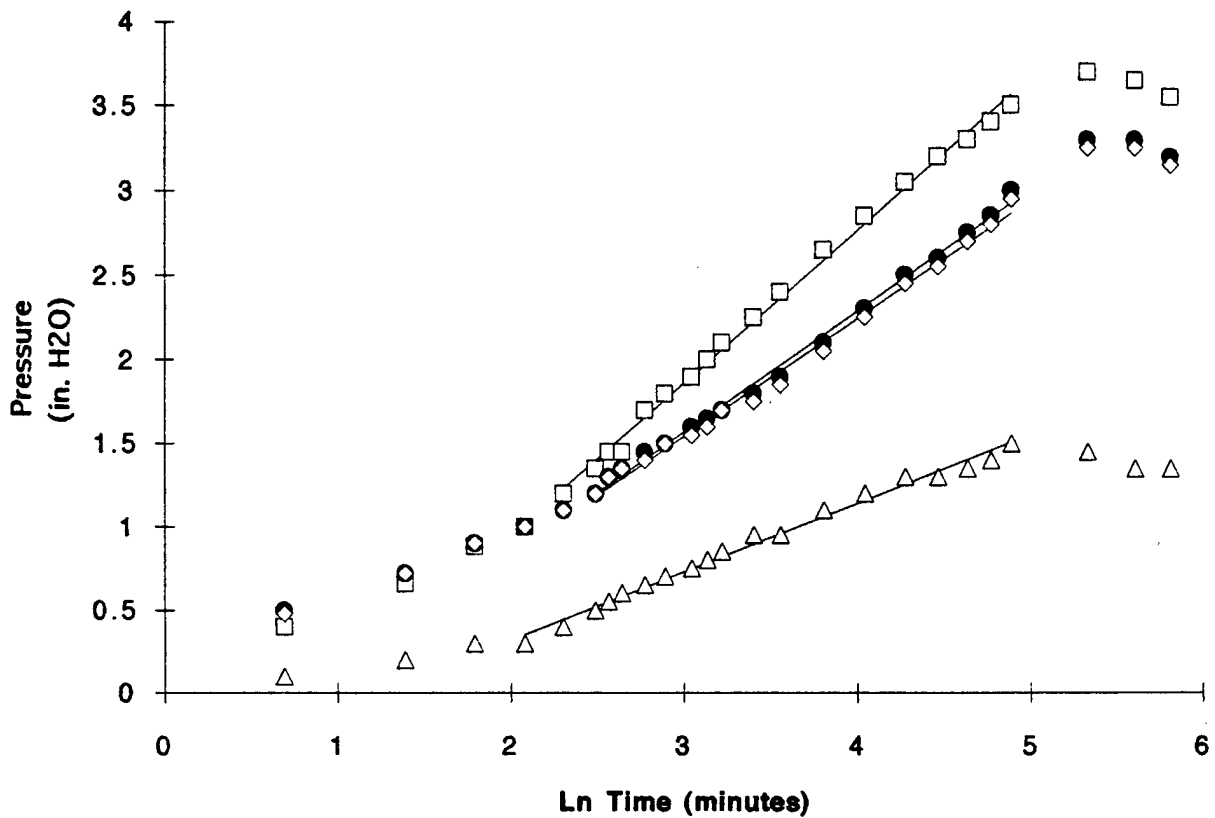

Figure 3.10
 Air Permeability Test
 Monitoring Points VMP1-30 and VMP1-65: r = 15 feet
 IRP Site 18
 Beale AFB, California



- VMP2-6
k = 10 darcys
- ◆ VMP2-11
k = 5 darcys
- VMP2-30
k = 9 darcys
- △ VMP2-65
k = 8 darcys
(k = air permeability)

Figure 3.11
 Air Permeability Test
 Monitoring Point VMP2: r = 30 feet
 IRP Site 18
 Beale AFB, California



- △ VMP3-6
k = 17 darcys
- VMP3-11
k = 8 darcys
- VMP3-30
k = 10 darcys
- ◇ VMP3-55
k = 10 darcys
(k = air permeability)

Figure 3.12
 Air Permeability Test
 Monitoring Point VMP3: r = 50 feet
 IRP Site 18
 Beale AFB, California

the slow response and relatively long time to achieve steady state, the HyperVentilate™ model was used to calculate air permeabilities (Hinchee et al, 1992). Calculated air permeability values ranged between 4 and 17 darcys at this site. The variation in calculated permeabilities is due to the varying sand and clay content of the soils. It is important to note that VMPs were screened at discrete intervals within both clay and silty-sand zones. Pressure influence and oxygen movement was apparent in all soil types. A radius of pressure influence of at least 50 feet was observed at all four depths.

3.2.3 Oxygen Influence

The depth and radius of oxygen increase in the subsurface resulting from air injection into the central VW during pilot testing is the primary design parameter for full-scale bioventing systems. Optimization of full-scale and multiple VW systems requires pilot testing to determine the volume of soil that can be oxygenated at a given flow rate and VW screen configuration.

Table 3.5 presents the change in soil gas oxygen levels that occurred during and after the 5.5-hour air permeability test at IRP Site 18. The final oxygen readings were taken the day after ending the injection period of the air permeability test due to site access limitations. An increase in oxygen levels results from the influx of fresh, oxygenated air while a decrease in oxygen concentration is an indication that soil gas from highly contaminated soils near the VW (with low oxygen levels) was displaced outward toward the VMPs. Over time, all VMPs should be influenced by highly oxygenated injected air. Based on measured pressure response, which is an indicator of long-term oxygen transport, and changes in oxygen levels, it is anticipated that the radius of oxygen influence for a long-term bioventing system at this site will exceed 50 feet at all depths. Monitoring during the extended pilot test at this site will better define the effective treatment radius.

3.2.4. *In Situ* Respiration Rates

The *in situ* respiration test was performed by injecting 1 cfm of air (20.8 percent oxygen) into four VMP screened intervals (VMP1-6, VMP1-11, VMP2-11, and VMP3-55) for a 20.5-hour period. Oxygen loss and other changes in soil gas composition over time were then determined. Oxygen, TVH, and carbon dioxide were measured for a period of 55.5 hours following air injection. Oxygen utilization rates were then used to calculate the biodegradation rates. The results of *in situ* respiration testing at this site are presented in Figures 3.13 through 3.16. Table 3.6 provides a summary of the observed oxygen utilization rates.

A 2.8-percent mixture of helium in air was injected into the VMP1-11 screened interval, and helium was measured for 55.5 hours following air injection. Because helium is a conservative, inert gas, the change in helium concentrations over time can be useful in determining the effectiveness of the bentonite seals between VMP screened intervals and if oxygen diffusion is responsible for a portion of the oxygen lost from each VMP. Figure 3.17 compares oxygen utilization and helium retention at VMP1-11. Because the observed helium loss was negligible, and because helium will diffuse approximately three times faster than oxygen, due to oxygen's greater molecular weight, the measured oxygen loss is assumed to be the result of bacterial respiration and not due to diffusion or faulty VMP construction.

TABLE 3.6
INFLUENCE OF AIR INJECTION AT VENT WELL
ON MONITORING POINT OXYGEN LEVELS
IRP SITE 18
BEALE AFB, CALIFORNIA

| Sample Location | Distance From VW (ft) | Depth(ft) | Initial O ₂ (%) | Final O ₂ (%) |
|-----------------|-----------------------|-----------|----------------------------|--------------------------|
| VMP1 | 15 | 6 | 1.5 | 0.0 |
| VMP1 | 15 | 11 | 3.0 | 0.0 |
| VMP1 | 15 | 30 | 2.5 | 1.0 |
| VMP1 | 15 | 65 | 5.5 | 11.5 |
| VMP2 | 30 | 6 | 10.0 | 10.5 |
| VMP2 | 30 | 11 | 2.0 | 0.0 |
| VMP2 | 30 | 30 | 7.5 | 13.0 |
| VMP2 | 30 | 65 | 12.5 | 7.5 |
| VMP3 | 50 | 6 | 1.0 | 3.0 |
| VMP3 | 50 | 11 | 1.0 | 0.0 |
| VMP3 | 50 | 30 | 5.0 | 1.0 |
| VMP3 | 50 | 55 | 2.0 | 1.0 |

Final O₂ readings taken the day following the air permeability test.

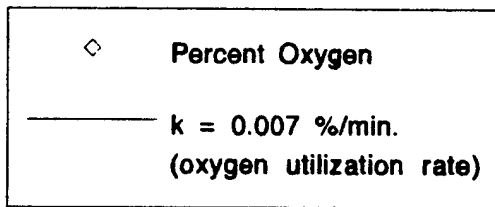
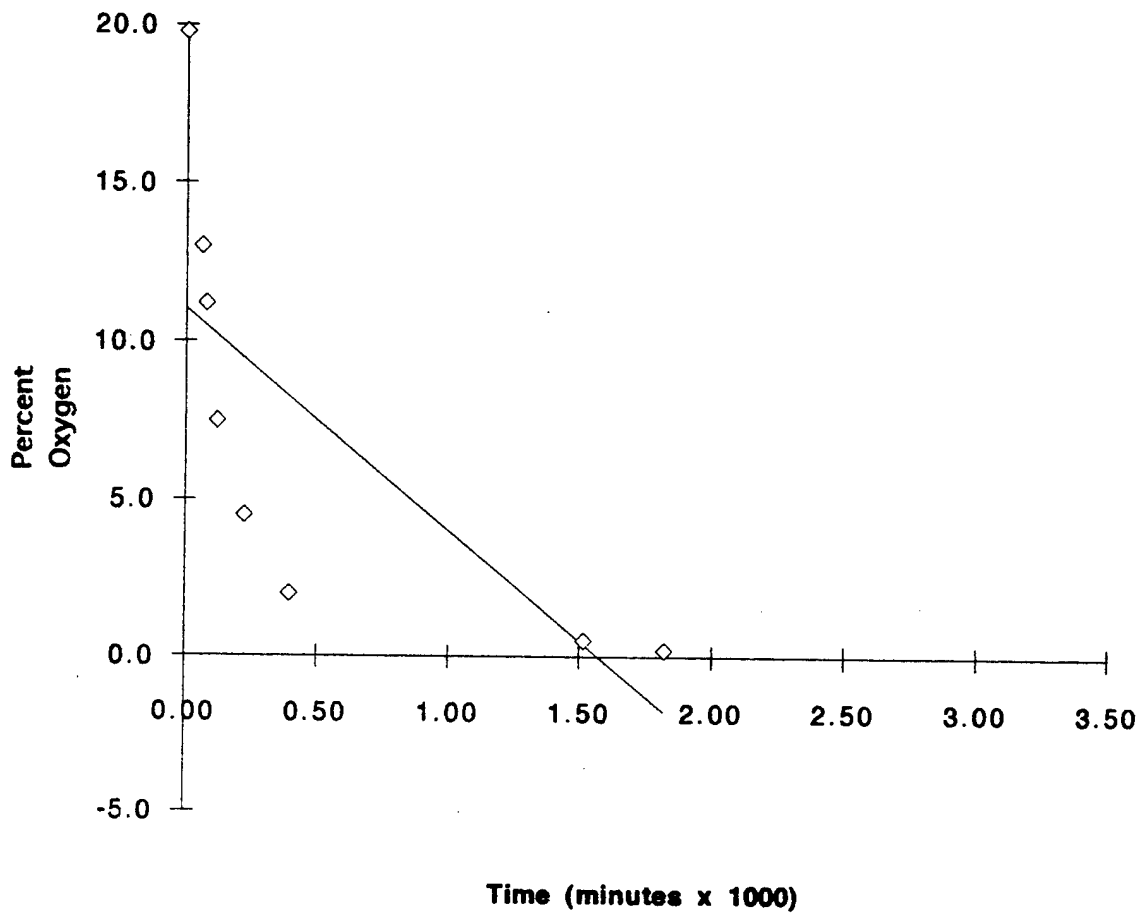
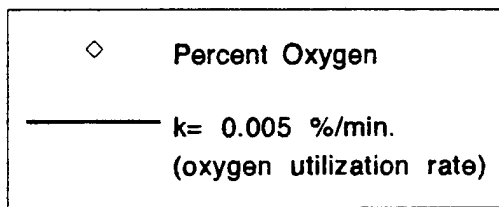
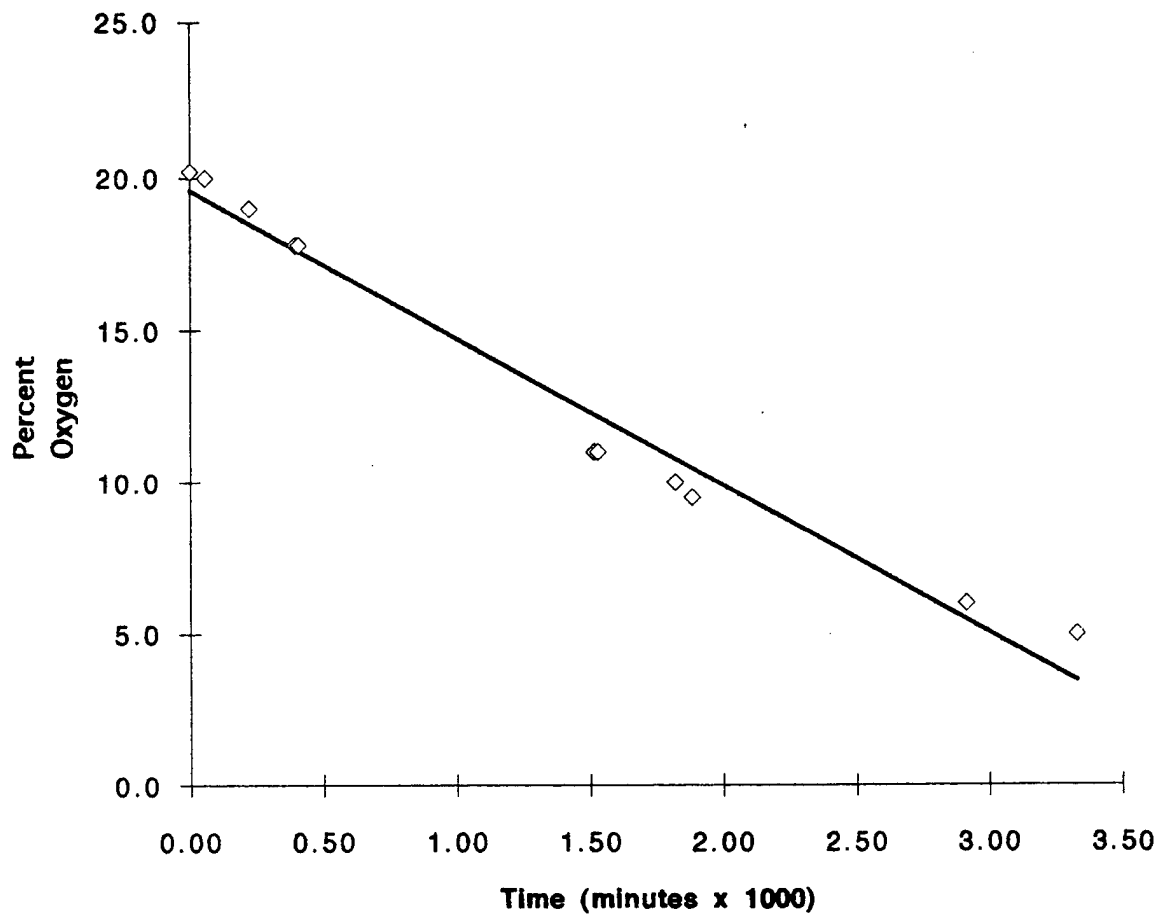
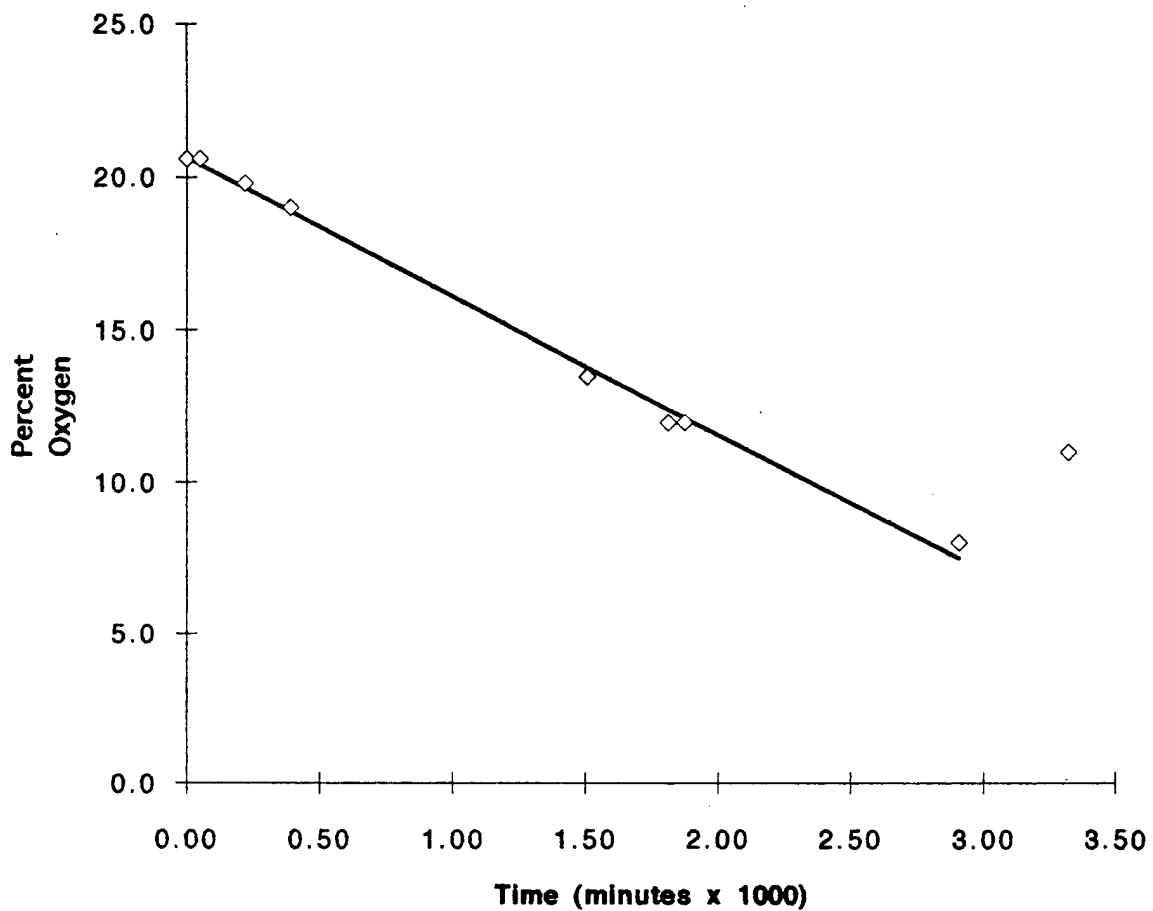

Figure 3.13
 Respiration Test
 IRP Site 18 : Monitoring Point VMP1-6
 Beale AFB, CA



TRPH = 40,000 mg/kg
(soil analysis result)

Figure 3.14
Respiration Test
IRP Site 18 : Monitoring Point VMP1-11
Beale AFB, CA



◇ Percent Oxygen
 — k= 0.005 %/min.
 (oxygen utilization rate)

TRPH = 3,900 mg/kg
 (soil analysis result)

Figure 3.15
 Respiration Test
 IRP Site 18 : Monitoring Point VMP2-11
 Beale AFB, CA

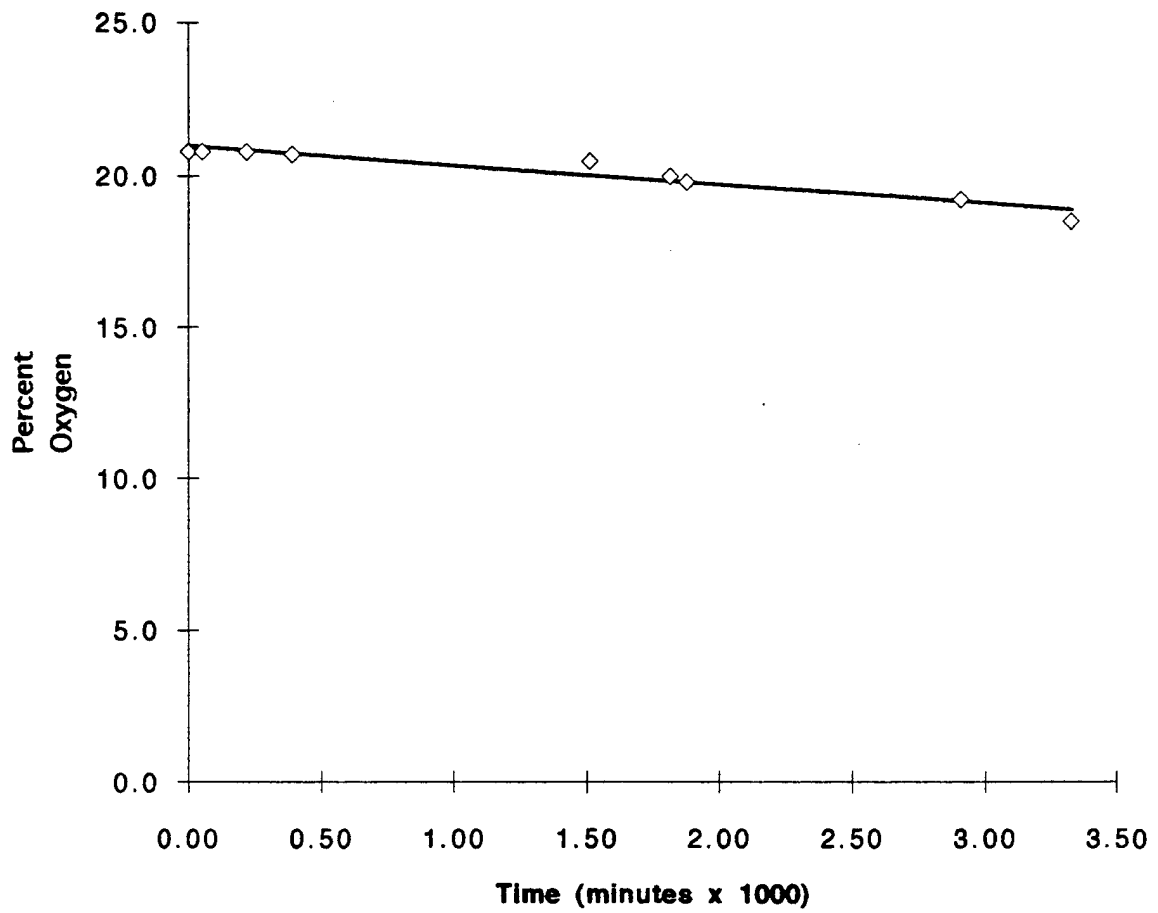

Figure 3.16
Respiration Test
IRP Site 18 : Monitoring Point VMP3-55
Beale AFB, CA

TABLE 3.7
OXYGEN UTILIZATION RATES
IRP SITE 18
BEALE AFB, CALIFORNIA

| Sample Location | Depth (ft) | Test Duration (min) | Initial O ₂ (%) | Final O ₂ (%) | O ₂ Utilization Rate (%/minute) |
|-----------------|------------|---------------------|----------------------------|--------------------------|--|
| VMP1 | 6 | 1,820 | 19.8 | 0.2 | 0.0070 |
| VMP1 | 11 | 3,330 | 20.2 | 5.0 | 0.0048 |
| VMP2 | 11 | 2,020 | 20.6 | 8.0 | 0.0045 |
| VMP3 | 55 | 3,330 | 20.8 | 18.5 | 0.00063 |

O₂ utilization rate is the slope of the graph of percent oxygen vs. time.

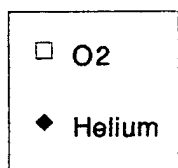
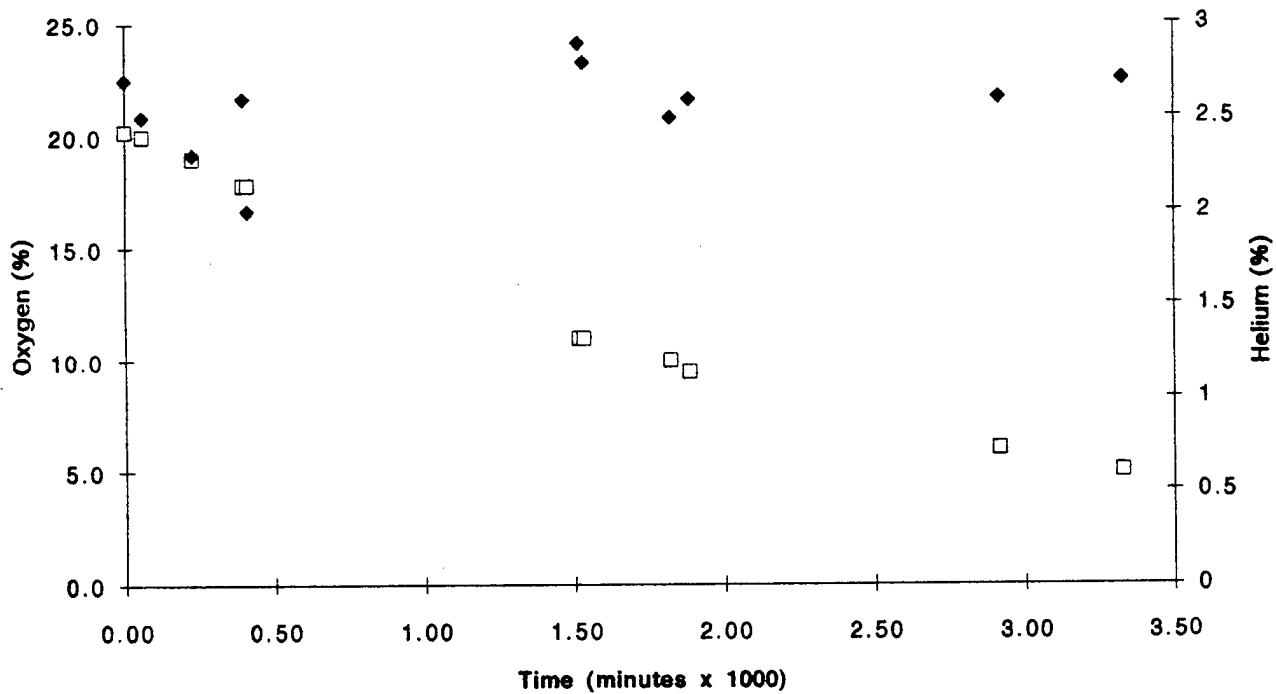

Figure 3.17
 Respiration Test
 Oxygen and Helium Concentrations
 Monitoring Point VMP1-11
 IRP Site 18
 Beale AFB, California

Results from this test indicate that three of the selected VMPs (VMP1-6, VMP1-11 and VMP2-11) had significant soil hydrocarbon contamination. These VMP intervals had initial oxygen concentrations of less than 3.0 percent, and soil samples from VMP1 and VMP2 at depths of 11 feet had TRPH concentrations of 40,000 and 3,900 mg/kg, respectively. Oxygen loss at these VMP intervals occurred at the moderate rates of 0.007, 0.0048 and 0.0045 percent oxygen per minute at VMP1-6, VMP1-11 and VMP2-11, respectively.

Based on oxygen utilization rates, an estimated 590 mg of fuel per kg of soil can be degraded each year at this site. This conservative estimate is based on an average air-filled porosity of 0.048 liter of air per kg of soil, and a ratio of 3.5 mg of oxygen consumed for every 1 mg of fuel biodegraded. Actual rates may exceed this estimate. Methods of calculation followed the technical protocol document (Hinchee et al., 1992). This biodegradation rate is expected to increase as continued air injection increases the air-filled porosity. Additional respiration testing at 6 months and respiration testing and soil sampling one year following the initial pilot test will better define the long-term biodegradation rates. Table 3.8 is a summary of data from the initial pilot test at IRP Site 18.

3.2.5 Potential Air Emissions

Although flux emissions were not sampled at IRP Site 18, it is anticipated that long-term emissions at this site will be minimal because the soil conditions and injection rates at IRP Site 18 are very similar to those at IRP Site 3 where flux emissions were measured as minimal. Higher initial soil gas TVH levels at Site 18 may result in higher initial emissions, but they should not exceed 50 grams per day. IRP Site 3, which had TVH measurements of up to 4,800 ppmv, had an estimated 5 g/day emission rate.

The accumulated hydrocarbon vapors in the soil will move slowly outward from the air injection point and will be biodegraded as they move horizontally through the soil. The potential for vertical soil vapor flow, and the resulting discharge to the atmosphere, is low because the layered structure of the unconsolidated deposits underlying this site favors horizontal air flow over vertical flow. The relatively impermeable clay soil near the ground surface also inhibits flow to the atmosphere.

3.2.6 Recommendations

Initial bioventing tests at this site indicate that oxygen has been depleted in the contaminated soils, and that air injection is an effective method of increasing aerobic biodegradation of fuel. AFCEE has recommended that air injection continue at this site to determine the long-term radius of oxygen influence and the effect of time, available nutrients, and changing temperatures on fuel biodegradation rates.

A small, 2.5-horsepower Gast™ regenerative blower was set-up on 19 November 1992 for the extended pilot test, and power was supplied on 14 January 1993 at IRP Site 18 to continue a rate of air injection of approximately 30 scfm. In July 1993, ES personnel will return to the site to sample and analyze the soil gas and conduct a second respiration test. In January 1994, a final respiration test will be conducted, and soil and soil gas samples will be collected from the site to determine the degree of remediation achieved during the first year of *in situ* treatment.

Table 3.8
PILOT TEST DATA SUMMARY
IRP Site 18: Bulk Fuel Storage Area
Beale AFB, California

| WELL No. - DEPTH | Soil Data | | Air Permeability Test | | | | In Situ Respiration Test | | | | Calculated Biodegradation Rate K_b (mg/kg fuel per year) | |
|------------------|-----------|--------------|-----------------------|---------------------|------------|-----------------|--------------------------|--|--------------|--------------|--|--------------|
| | Soil Type | Soil Anal. | Initial Soil Gas | Final Soil Gas | Air Perm. | Init. O_2 (%) | Final O_2 (%) | O ₂ Util. Rate k_0 (% O ₂ /hr) | Init. He (%) | Final He (%) | | He Diff. (%) |
| VMP1-6 | cly SILT | TRPH (mg/kg) | O_2 (%) | CO ₂ (%) | TVH (ppmv) | O_2 (%) | Final O_2 (%) | Final O_2 (%) | Final He (%) | Final He (%) | Final He (%) | 590 |
| VMP1-11 | SAND | 40,000 | 1.5 | 9.5 | 1,400 | 0.0 | 0.0 | 0.42 | 19.8 | 0.2 | 0.42 | 590 |
| VMP1-30 | sly CLAY | | 3.0 | 8.0 | | 0.0 | 0.0 | 0.29 | 20.2 | 10.2 | 0.29 | |
| VMP1-65 | cly SILT | | 2.5 | 3.0 | | 1.0 | 10 | | | | | |
| VMP2-6 | cly SILT | | 5.5 | <0.5 | | 11.5 | 11 | | | | | |
| VMP2-11 | cly SAND | 3,900 | 10.0 | 6.0 | | 10.5 | | | | | | 590 |
| VMP2-30 | CLAY | | 2.0 | 9.0 | | 0.0 | | 0.27 | 20.6 | 8.0 | 0.27 | |
| VMP2-65 | cly SILT | | 7.5 | 1.5 | | 13.0 | 9 | | | | | |
| VMP3-6 | cly SILT | | 12.5 | 1.5 | | 7.5 | 9 | | | | | |
| VMP3-11 | cly SAND | | 1.0 | 11.5 | 7,900 | 3.0 | | | | | | |
| VMP3-30 | sly CLAY | | 1.0 | 9.0 | | 0.0 | | | | | | |
| VMP3-55 | sly CLAY | 5 | 5.0 | 3.5 | | 1.0 | 13 | | | | | |
| VW1-(10 - 60) | | 24,000 | 2.0 | 6.0 | | 1.0 | 12 | | 20.8 | 18.5 | 0.04 | |

NOTES:

- Sample was not taken/analyzed.

TRPH - Total Recoverable Petroleum Hydrocarbons (laboratory results)

TVH - Total Volatile Hydrocarbons (laboratory results)

VW1 Soil sample collected from 11 ft. bgs.

Air Permeability Test conducted for 5.5hrs; injection at 38 scfm (avg. press. = 3.0psi).

Air Permeability calculation by HyperVentilate computer program.

Final O₂ readings for the Air Permeability Test taken the next day, after the end of the 5.5hr injection period.

In Situ Respiration Test: injection at 1cfm for 20.5hrs; O₂/CO₂/TVH/He measurements in VMPs taken for 55.5hrs following injection;

O₂/CO₂/TVH measurements in VW taken for 55.5hrs following injection.

Oxygen Utilization Rate calculation by HyperVentilate computer program.

Helium Diffusion is percent fractional loss of He following injection.

Biodegradation Rate calculation by the HyperVentilate computer program. Assumptions used: * Avg. air-filled porosity of 0.048 liter of air per kg of soil.

* Ratio of 3.5mg O₂ consumed per 1mg fuel biodegraded.

mg/kg - Milligrams per kilogram (parts per million - ppm)

ppmv - Parts per million, volume per volume

Based on results presented by ES for the first year of pilot-scale bioventing, AFCEE will recommend one of two options:

1. Upgrade, if necessary, and continue operation of the bioventing system for full-scale remediation of the site. AFCEE can assist the base in obtaining regulatory approval for upgrading and continued operation.
2. If significant difficulties or poor results are encountered during bioventing at this site, AFCEE may recommend removal of the blower system and proper abandonment of the VW and VMPs.

4.0 REFERENCES

Hinchee, R.E., S.K. Ong., R.N. Miller, and D.C. Downey. 1992. *Test Plan and Technical Protocol for a Field Treatability Test for Bioventing*. Prepared for USAF Center for Environmental Excellence. May.

APPENDIX A
GEOLOGIC BORING LOGS

BOREHOLE NUMBER: 1 (VW-1)

| | |
|---|-------------------------------------|
| PROJECT NUMBER: DE 268.20.04 | PROJECT NAME: BIOVENTING INITIATIVE |
| CLIENT: AFCEE | DRILLER: PC EXPLORATION |
| LOCATION: BEALE AFB, CA IRP SITE 3: FPTA No. 1 | DRILLING METHOD: HOLLOW-STEM AUGER |
| GEOLOGIST: HENRY PIETRO PAOLI | HOLE DIAMETER: 11" |
| COMPLETION DATE: | TOTAL DEPTH: 31.5 FT BGS |

| DEPTH feet | SAMPLE LOCATION | SAMPLE NUMBER | BLOW COUNT | PID (ppm) [THVA] (ppm) | GRAPHIC LOG | SOIL CLASS | GEOLOGIC DESCRIPTION |
|---------------|-----------------|---------------|-------------|------------------------------|-------------|------------|--|
| 5 | | | 15/25 22 | 78 [62] | | | CLAY: silty, red-brn, dry, w/rd qtz gravel (fill?), dense. CLAY: silty, lgt red-brn, dry, dense, discolored blue-green, paint/fuel odor. At 8', occ gravel, white streaks. |
| 10 | BE 3-VW-10 | | 30/50 | 470 [360] 663 [240] | | | SAND: med grd, silty, clayey, discolor blue-grn, loose, damp, white streaks, fuel odor, occ gravel. SAND: silty, fine grd, brn, v loose, dry to damp, mod sort, fuel odor. Lgt brn @ 14.5' |
| 15 | | | 32/50 | 68 [22] | | | CLAY: silty, sli plastic, moist, mod stiff, damp, fuel odor. |
| 20 | | | 22/27 50 | 96 [24] | | | CLAY: lgt tan, abundant Fe-staining, plastic, stiff, damp, black streaks. Lens of sand > 20-20.5'. Grades to lgt tan clay. |
| 25 | | | 23/50 | 8.3 [15] | | | CLAY: silty, lgt yel-grn w/brn mottling, with fine sand, damp, mod stiff, abund black patches. |
| 30 | | | 48/50 | 31 [4] | | | CLAY: gravelly, silty, dk red brn, moist, round gravel (chert + volcanics), soft. GRAVEL: sandy, moist, loose. |

- Equilibrated waterlevel.
 - First encountered groundwater.

- Brass tube sample submitted for laboratory analysis

TOTAL DEPTH: 31.5' BGS.
 BOREHOLE BACKFILLED WITH BENTONITE TO 25'
 BGS; COMPLETED AS A VENT WELL (VW-1).

BOREHOLE NUMBER: 2

| | |
|---|-------------------------------------|
| PROJECT NUMBER: DE 268.20.04 | PROJECT NAME: BIOVENTING INITIATIVE |
| CLIENT: AFLEE | DRILLER: PC EXPLORATION |
| LOCATION: BEALE AFB, CA IRP SITE 3: FPTA No. 1 | DRILLING METHOD: HOLLOW-STEM AUGER |
| GEOLOGIST: HENRY PIETROPADLI | HOLE DIAMETER: 11" |
| COMPLETION DATE: | TOTAL DEPTH: 31.5' BGS |

| DEPTH feet | SAMPLE LOCATION | SAMPLE NUMBER | BLOW COUNT | PID (ppm) (THVA) (ppm) | GRAPHIC LOG | SOIL CLASS | GEOLOGIC DESCRIPTION |
|---------------|-----------------|---------------|----------------|---------------------------|-------------|------------|---|
| | | | | | | | CLAY: silty, gravelly, med brn, sli plastic, mod stiff, damp. |
| 5 | | | 27 33 50 | 183 (42) | | | SAND: med grd, clayey, red-brn, dry, stiff, black inclusions, sli plastic, blue discoloration patches, fuel/paint odor. @ 9' bgs, incr. in silt, incr in blue discoloration. |
| 10 | | | 33 50 | 436 (180) | | | SAND: clayey, blue-grn, fuel/paint odor, dry, stiff, sli plastic. SAND: med-well sort, med grd, lgt grn-yell, red-brn mottled, loose, dry. |
| 15 | | | 28 36 50 | 424 (16) | | | CLAY: fn sdy, silty, lgt tan w/red-brn spots, sli plastic, mod stiff damp, paint odor, black spots/inclusions. |
| 20 | | | NR | 40 (2) | | | CLAY: as above w/inc. sand content. |
| 25 | | | 20 23 32 | 35 (0) | | | SAND: clayey, micaceous CLAY: lgt tan as above. |
| | | | | | | | GRAVEL: clayey, sandy, red-brn. |
| 30 | | | 19 24 50 | 78 (0) | | | GRAVEL: coarse grained CLAY: lgt tan as above. |

- ▼ - Equilibrated waterlevel.
- ▽ - First encountered groundwater.

■ - Brass tube sample submitted for laboratory analysis

TOTAL DEPTH: 31.5' BGS
Borehole backfilled and abandoned.

BOREHOLE NUMBER: 3 (VMP-3)

| | |
|------------------------------|--------------------------------------|
| PROJECT NUMBER: DE 268.20.04 | PROJECT NAME: BIODVENTING INITIATIVE |
| CLIENT: AFCEE | DRILLER: PC EXPLORATION |
| LOCATION: BEALE AFB, CA | DRILLING METHOD: HOLLOW-STEM AUGER |
| IRP SITE 3: FPTA No. 1 | |
| GEOLOGIST: HENRY PIETROPAOLI | HOLE DIAMETER: 11" |
| COMPLETION DATE: | TOTAL DEPTH: 30.0 FT BGS |

| DEPTH feet | SAMPLE LOCATION | SAMPLE NUMBER | BLOW COUNT | PID (ppm) (FNUA) (ppm) | GRAPHIC LOG | SOIL CLASS | GEOLOGIC DESCRIPTION |
|---------------|-----------------|---------------|-----------------|---------------------------|--------------------------|------------|---|
| 0-5 | | | 29/ 50 | 52 (0) | [Hand-drawn log symbols] | | CLAY: silty, lgt yel-brn, topsoil, minor black asphalt-like fragments (fill?). |
| 5-10 | | | 26/ 50 | 1 (2) | [Hand-drawn log symbols] | | CLAY: silty, lgt brn, hard, sl: plastic, dry, dark black. |
| 10-15 | | | 15/ 27 50 | 5 (0) | [Hand-drawn log symbols] | | SAND: fngrd, silty, lgt yel brn, black inclusions and streaks of organics, micaceous, dry, med dns. |
| 15-20 | | | 15/ 27 50 | 0 (0) | [Hand-drawn log symbols] | | CLAY: lgt tan, red-brn Fe-staining, mottling, occ blk spots, soft, moist, plastic, occ silt. |
| 20-25 | | | 27/ 50 | 2 (0) | [Hand-drawn log symbols] | | CLAY: as above, grades to silty clay. |
| 25-30 | | | | | [Hand-drawn log symbols] | | SAND: Fine, silty, dense, damp. |
| 30 | | | | | [Hand-drawn log symbols] | | GRAVEL: very hard. |

- ▼ - Equilibrated waterlevel.
- ▽ - First encountered groundwater.

■ - Brass tube sample submitted for laboratory analysis

TOTAL DEPTH: 30.0' BGS
 COMPLETED AS A VAPOR MONITORING POINT (VMP-3) jm2

BOREHOLE NUMBER: 4C (VMP-2)

| | |
|------------------------------|-------------------------------------|
| PROJECT NUMBER: DE 268.20.04 | PROJECT NAME: BIOVENTING INITIATIVE |
| CLIENT: AFCEE | DRILLER: PC EXPLORATION |
| LOCATION: BEALE AFB, CA | DRILLING METHOD: HOLLOW-STEM AUGER |
| IRP SITE 3: FPTA No. 1 | |
| GEOLOGIST: HENRY PIETROPAOLI | HOLE DIAMETER: 11" |
| COMPLETION DATE: | TOTAL DEPTH: 26.3' BGS |

| DEPTH feet | SAMPLE LOCATION | SAMPLE NUMBER | BLOW COUNT | PID (ppm) (TVA) (ppm) | GRAPHIC LOG | SOIL CLASS | GEOLOGIC DESCRIPTION |
|---------------|-----------------|---------------|----------------|--|-------------|------------|--|
| 0-5 | | | | | | | SILT: clayey, red-brn, dry, stiff, occ gravel (fill?) |
| 5-10 | | | | 435 (120) | | | CLAY: silty, discolored blue-green, damp, sli plastic, mod stiff, fuel/paint odor |
| 10-15 | BE3-VMP2-9 | | 27/39/42 NR | 860 (610) (669) (390) (578) (380) | | | CLAY: silty, mottled green, damp, paint odor, sli plastic, hard. |
| 15-20 | | | 15/17/24 | 22 (0) | | | SAND: fine grd, grn-brn, clayey, damp, loose, paint/fuel odor. |
| 20-25 | | | 27/38/50 | 13 (1) | | | CLAY: lgt tan, plastic, damp, mod stiff, black spots/streaks, abund Fe-staining. |
| 25-30 | | | 21/32/50 | 0 (0) | | | CLAY: Frsdy, red brn, damp, stiff, black spots/streaks, sli plastic. CLAY: silty, med brn, sli plastic, stiff, damp. |
| 30-26.3 | | | | | | | 4C TOTAL DEPTH: 26.3' bgs; completed as a Vapor Monitoring Point (VMP-2) #4 TOTAL DEPTH: 11.5' - backfilled #4A TOTAL DEPTH: 25' - abandoned #4B TOTAL DEPTH: 4' - backfilled |

- Equilibrated waterlevel.
 - First encountered groundwater.

- Brass tube sample submitted for laboratory analysis

BOREHOLE NUMBER: 5

| | |
|------------------------------|------------------------------------|
| PROJECT NUMBER: DE 268.20.04 | PROJECT NAME: BIDENTING INITIATIVE |
| CLIENT: AFCEE | DRILLER: PC EXPLORATION |
| LOCATION: BEALE AFB, CA | DRILLING METHOD: HOLLOW-STEM AUGER |
| IRP SITE 3: FPTA No. 1 | |
| GEOLOGIST: HENRY PIETROPAOLI | HOLE DIAMETER: 11" |
| COMPLETION DATE: | TOTAL DEPTH: 11.5' BGS |

| DEPTH feet | SAMPLE LOCATION | SAMPLE NUMBER | BLOW COUNT | PIB (ppm) [SVA] (ppm) | GRAPHIC LOG | SOIL CLASS | GEOLOGIC DESCRIPTION |
|---------------|-----------------|------------------|---------------|--------------------------|-------------|------------|---|
| 5 | | | NR | 571 [180] | | | CLAY: discolored blue-green, soft, plastic, damp, paint odor. |
| 10 | | | 42/ 50 | 22 [0] | | | SAND: silty, fngrd, lgt brn, hard, damp. |
| | | | | | | | TOTAL DEPTH: 11.5' BGS. BOREHOLE BACKFILLED AND ABANDONED |

- Equilibrated waterlevel.
- First encountered groundwater.
- Brass tube sample submitted for laboratory analysis

SECTION 3

SYSTEM MAINTENANCE

3.1 BLOWER/MOTOR MAINTENANCE

Although the motor is relatively maintenance free, the blower requires periodic maintenance for proper operation and long life. Recommended maintenance procedures and schedules are described in detail in the instruction manual included in Appendix A and briefly summarized in this section.

Filter inspection and knock-out pot draining (as applicable) must be performed with the system turned off. To re-start the motor, open the manual air dilution valve (red handle) to protect the motor from excessive strain, start motor, and slowly close dilution valve to its original setting.

3.1.1 Lubrication

Regenerative blowers require no lubrication.

3.2 KNOCK-OUT CHAMBER MAINTENANCE

This section applies only to vapor extraction systems equipped with moisture knock-out pots. To avoid damage caused by passing liquids solids through the blower a knock-out pot has been installed in-line before the blower.

Free liquid should not be pumped through the blower. The knock-out pot installed in-line before the blower intercepts entrained liquid, preventing damage to the blower. The knock-out pot should be drained once a month for the first few months and at longer intervals thereafter, if it appears that this will be sufficient to keep liquid from building up in the knock-out pot. Condensation generally increases during the cold winter months. A base employee should determine the best schedule to drain the knock-out pot. The knock-out pot can be drained by turning the system off and removing the 2" diameter cap at the base of the knock-out pot. When all of the liquid has drained out the system can be turned back on. It is recommended when re-starting the system that the air dilution valve (red-handled valve) be opened to protect the motor from excessive strain. If oily, liquids should be disposed of in an oil-water separator.

3.3 AIR FILTER MAINTENANCE

To avoid damage caused by passing solids through the blower an air filter has been installed in-line before the blower.

The filter element is paper and is accompanied by a polyurethane foam prefilter. The filter should be checked weekly for the first two months of operation. Again, a base employee should determine the best schedule for filter replacement. The polyurethane prefilters can be washed with lukewarm water and a mild detergent. Paper filter elements should never be washed but should be disposed of and replaced as necessary. When the pressure or vacuum drop across the filter is above 15 inches of water, a dirty filter element should be suspected and cleaning or replacement should be performed.

To remove the filter, loosen the three clamps or the wing nut, lift the metal top off the air filter, and lift the air filter from the metal housing. Remove the polyurethane prefilter (if applicable) and wash before replacing. When replacing the filter, be careful that the rubber seals remain in place.

The filter is manufactured by Solberg Manufacturing, Inc. in Itasca, Illinois. Their phone number is (708) 773-1363. Additional filters can also be obtained through Engineering-Science, Inc. in Denver, Colorado. The ES contacts are Mr. Brian Blicher and Ms. Lisa Williams and they can be reached at (303) 831-8100. The filter model number is _____, and the number for the replacement element is _____. It is recommended that _____ AFB keep at least one spare air filter at the site, four spare filters were supplied with the blower system.

3.4 MAINTENANCE SCHEDULE

The following maintenance schedule is recommended for this system. During the initial months of operation more frequent monitoring is recommended to ensure that any start up problems are quickly corrected. A daily drive-by inspection is recommended during the initial two weeks of operation to ensure that the blower system is still operating with no unusual sounds. Data collection sheets have been provided to assist your data collection and are included in Appendix B.

| <u>Maintenance Item</u> | <u>Maintenance Frequency</u> |
|-------------------------|---|
| Filter | Check once per month. |
| Knock-out chamber | Once per month initially, then periodically (see Section 3.2). |

3.5 MAJOR REPAIRS

Blowers systems are very reliable when properly maintained. Occasionally, a motor or blower will develop serious problems. If a blower system fails to start, and a base electrician verifies that power is available at the starter, the Engineering-Science site manager _____ should be called at () _____. Engineering-Science is responsible for major repairs during the first year of operation.

SECTION 4

SYSTEM MONITORING

4.1 BLOWER PERFORMANCE MONITORING

To monitor the blower performance, vacuum, pressure and temperature will be measured. These data should be recorded weekly on a data collection sheet provided in Appendix B. All measurements should be taken at the same time while the system is running. Since the system is loud, ear protection should be worn at all times.

4.1.1 Vacuum/Pressure

With ear protection on, open the enclosure and record all vacuum and pressure readings directly from the gauges (in inches of water). Record the measurements on the data collection sheet provided in Appendix B.

4.1.2 Flow Rate

The flow rate through the vent well and soils can be calculated when the inlet vacuum and outlet pressure of the blower are known. This pressure change across the blower (vacuum + pressure) can be compared to the performance curves for the blower in Appendix A to determine the approximate flow rate.

4.1.3 Temperature

With ear protection on, open the enclosure and record the temperature readings directly from the gauges in degrees Fahrenheit. Record the measurements on the data collection sheet provided in Appendix B. The temperature change can be converted to degrees Celsius ($^{\circ}\text{C}$) using the formula $^{\circ}\text{C} = (^{\circ}\text{F} - 32) \times 5/9$.

4.3 MONITORING SCHEDULE

The following monitoring schedule is recommended for this system. During the initial months of operation more frequent monitoring is recommended to ensure that any start up problems are quickly corrected. Data collection sheets have been provided to assist your data collection and are included in Appendix B.

| <u>Monitoring Item</u> | <u>Monitoring Frequency</u> |
|------------------------|---|
| Vacuum/Pressure | Daily during first week, then twice per week. |
| Temperature | Daily during first week, then twice per week. |

APPENDIX A



Post Office Box 97
 Benton Harbor, Michigan 49023-0097
 Ph: 616/926-6171
 Fax: 616/925-8288

Maintenance Instructions for Gast Standard Regenerative Blowers

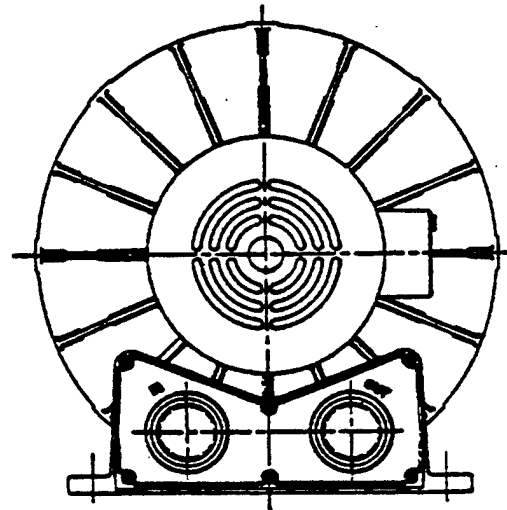
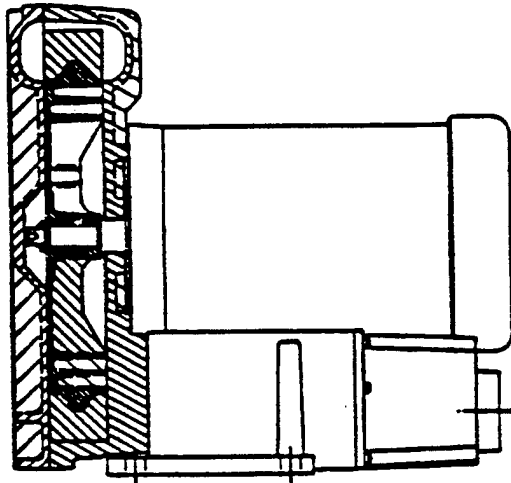

For original equipment manufacturers
 special models, consult your local distributor

Gast Rebuilding Centers

Gast Mfg. Corp.
 2550 Meadowbrook Rd.
 Benton Harbor MI. 49022
 Ph: 616/926-6171
 Fax: 616/925-8288

Gast Mfg Corp.
 505 Washington Avenue
 Carlstadt, N. J. 07072
 Ph: 201/933-8484
 Fax: 201/933-5545

Brenner Fiedler & Assoc.
 13824 Bentley Place
 Cerritos, CA. 90701
 Ph: 213/404-2721
 Fax: 213/404-7975

Wainbee, Limited
 121 City View Drive
 Toronto, Ont. Canada M9W 5A9
 Ph: 416/243-1900
 Fax: 416/243-2336

Wainbee, Limited
 215 Brunswick Drive
 Pointe Claire, P.Q. Canada H9R 4R7
 Ph: 514/697-8810
 Fax: 514/697-3070

Gast Mfg. Co. Limited.
 Halifax Rd, Cressex Estate
 High Wycombe, Bucks HP12 3SN
 Ph. 44 494 523571
 Fax: 44 494 436588

Japan Machinery Co. Ltd.
 Central PO Box 1451
 Tokyo 100-91 Japan
 Ph: 813/3573-5421
 Fax: 813/3571-7865

1st Q

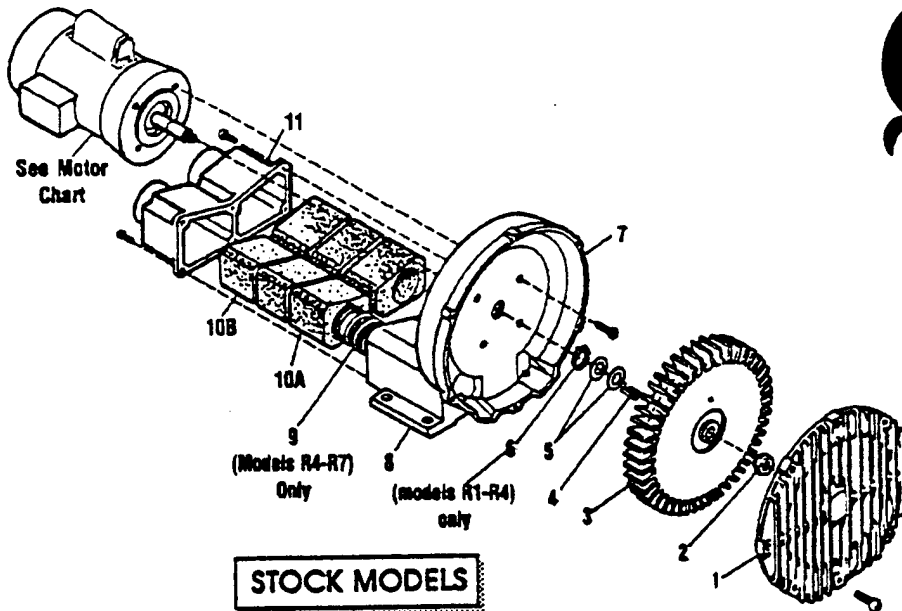

| Part Name | R1 | R2 | R3 | R4 | R5 | R6 | R6P | R6PP/R6PS | R7 |
|-------------------------------------|-----------|------------|------------|------------|------------|-----------|-----------|------------|-----------------|
| Cover | AJ101A | AJ101B | AJ101C | AJ101D | AJ101EQ | AJ101F | AJ101K | (2)AJ101KA | AJ101G |
| Topnut | BC187 | BC187 | BC181 | BC181 | BC181 | BC181 | BC181 | (2)BC182 | BC183 |
| Impeller | AJ102A | AJ102BQ | AJ102C | AJ102D | AJ102E | AJ102FR | AJ102K | (2)AJ102KA | AJ102GA |
| Square Key | AH212C | AH212 | AB136A | AB136D | AB136 | AB136 | AB136 | (2)AB136 | AC628 |
| Shim Spacer (s) | AJ132 | AE686-3 | AJ109 | AJ109 | AJ109 | AJ116A | AJ116A | AJ116A | AJ110 |
| Retaining Ring | AJ145 | AJ145 | AJ149 | AJ149 | | | | | |
| Gousing | AJ103A | AJ103BQ | AJ103C | AJ103DR | AJ103E | AJ103F | AJ103K | AJ103KD | AJ103GA |
| Muffler Box | | | | | AJ104E | AJ104F | | | |
| Spring | | | | AJ113DR | AJ113DQ | AJ113FQ | AJ113FQ | | AJ113G |
| OA Foam | (4)AJ112A | (4)AJ112B | (4)AJ112C | (4)AJ112DS | (4)AJ112ER | (6)AJ112F | (8)AJ112K | | (8)AJ112GA |
| B Foam | | (2)AJ112BQ | (2)AJ112CQ | (2)AJ112DR | (2)AJ112EQ | | | | |
| Muffler Extension/ Adapter Plate | AJ106H | AJ106BQ | AJ106CQ | AJ106DQ | AJ106EQ | AJ106EQ | AJ104K | | AJ104GA K395 |
| Trim Kit | K396 | K396 | | | | | | | |

MOTOR CHART

| EGENAIR MODEL NUMBER | MOTOR NUMBER | MOTOR SPECIFICATIONS | | PHASE |
|----------------------|--------------|----------------------|-------------|-------|
| | | 60 HZ VOLTS | 50 HZ VOLTS | |
| 1102 | J111X | 115/208-230 | 110/220-240 | 1 |
| R1102C | J112X | 115 | | 1 |
| R2103 | J311X | 115/208-230 | 110/220 | 1 |
| 2105 | J411X | 115/208-230 | 110/220 | 1 |
| 2303A | J310 | 208-230/460 | 220/380-415 | 3 |
| R2303F | J313 | 208-230 | 220 | 3 |
| P3105-1/R3105-12 | J411X | 115/208-230 | 110/220-240 | 1 |
| 3305A-1/R3305A-13 | J410 | 208-230/460 | 220/380-415 | 3 |
| 4110-2 | J611AX | 115/208-230 | 110/220-240 | 1 |
| R4310A-2 | J610 | 208-230/460 | 220/380-415 | 3 |
| 5125-2 | J811X | 115/208-230 | | 1 |
| 5325A-2 | J810X | 208-230/460 | 220/380-415 | 3 |
| R6125-2 | J811X | 115/208-230 | | 1 |
| R6325A-2 | J810X | 208-230/460 | 220/380-415 | 3 |
| 6335A-2 | J910X | 208-230/460 | 220/380-415 | 3 |
| 6150J-2 | J1013 | 230 | | 1 |
| R6350A-2 | J1010 | 208-230/460 | 220/380-415 | 3 |
| R6P335A | J910X | 208-230/460 | 220/380-415 | 3 |
| 6P350A | J1010 | 208-230/460 | 220/380-415 | 3 |
| 6P355A | J1110A | 208-230/460 | 220/380-415 | 3 |
| R7100A-2 | J1210B | 208-230/460 | 220/380-415 | 3 |
| R6PP/R6PS3110M | JD1100 | 208-230/460 | 220/380-415 | 3 |

* No lubrication needed at start up. Bearings lubricated at factory.

* Motor is equipped with a demite fitting. Clean tip of fitting and apply grease gun. Use 1 to 2 strokes of high quality ball bearing grease.

| Consistency | Type | Typical Grease |
|-------------|---------|----------------|
| Medium | Lithium | Shell Dolum R |

| Hours of service per year | Suggested Retube Interval |
|--|--|
| 5,000 | 3 years |
| Continual Normal Application | 1 year |
| Seasonal service motor idle for 6 months or more | 1 year beginning of season 6 months |

Continual Normal Application 1 year

Seasonal service motor idle for 6 months or more 1 year beginning of season 6 months

Continuous-high ambient, dirty or moist applications.

60 HZ FLOW DATA (CFM)

All performance figures relate to stock models. A few high pressure units may be available. Consult your local distributor.

| Regenair Model Number | P R E S S U R E | | | | | | Maximum Pressure "H ₂ O" |
|-----------------------|------------------------|---------------------|---------------------|---------------------|---------------------|----------------------|-------------------------------------|
| | 0"H ₂ O | 20"H ₂ O | 40"H ₂ O | 60"H ₂ O | 80"H ₂ O | 100"H ₂ O | |
| R1 | 26 | 14 | | | | | 28 |
| R2 | 42 | 26 | | | | | 38 |
| R3105-1 | 52 | 38 | 14 | | | | 42 |
| R3105-12 | 52 | 36 | 23 | | | | 55 |
| R3305A-13 | 52 | 36 | 23 | | | | 55 |
| R4 | 90 | 70 | 50 | | | | 52 |
| R5 | 145 | 130 | 100 | | | | 65 |
| R6125-2 | 200 | 160 | | | | | 35 |
| R6325A-2 | 200 | 180 | 152 | | | | 40 |
| R6335A-2 | 205 | 175 | 155 | 135 | | | 70 |
| R6350A-2 | 200 | 180 | 150 | 130 | 110 | 80 | 105 |
| R6P335A | 290 | 250 | | | | | 30 |
| R6P350A | 300 | 260 | 230 | 200 | | | 60 |
| R6P355A | 300 | 260 | 230 | 200 | 160 | | 90 |
| R7100A-2 | 420 | 380 | 340 | 310 | 280 | 230 | 115 |
| R6PP311OM | 485 | 452 | 420 | 380 | 330 | | 95 |
| R6PS311OM | 265 | 258 | 252 | 244 | 236 | 226 | 170 |

| Regenair Model Number | V A C U U M | | | | | Maximum Vacuum "H ₂ O" |
|-----------------------|--------------------|---------------------|---------------------|---------------------|---------------------|-----------------------------------|
| | 0"H ₂ O | 20"H ₂ O | 40"H ₂ O | 60"H ₂ O | 80"H ₂ O | |
| R1 | 25 | 14 | | | | 26 |
| R2 | 40 | 22 | | | | 34 |
| R3105-1 | 50 | 34 | 9 | | | 40 |
| R3105-12 | 51 | 34 | 20 | | | 50 |
| R3305A-13 | 51 | 34 | 20 | | | 50 |
| R4 | 82 | 62 | 39 | | | 48 |
| R5 | 140 | 115 | 90 | 50 | | 60 |
| R6125-2 | 190 | 155 | 125 | | | 45 |
| R6325A-2 | 190 | 155 | 125 | | | 45 |
| R6335A-2 | 190 | 150 | 125 | 100 | | 75 |
| R6350A-2 | 190 | 180 | 150 | 100 | 70 | 90 |
| R6P335A | 270 | 230 | | | | 37 |
| R6P350A | 280 | 240 | 210 | 170 | | 70 |
| R6P355A | 280 | 240 | 210 | 170 | 100 | 86 |
| R7100A-2 | 410 | 350 | 300 | 250 | 170 | 90 |
| R6PP311OM | 470 | 425 | 375 | 320 | 220 | 80 |
| R6PS311OM | 240 | 225 | 210 | 195 | 175 | 130 |

*This number indicates the maximum static pressure differential recommended (with cooling air still flowing through unit). In general, units 1hp or less can be dead headed. Check with local representative or distributor to verify which models apply.

Operation of the blower above the recommended maximum duty will cause premature failure due to the build up of heat damaging the components.

Performance data was determined under the following conditions:

- 1) Unit in a temperature stable condition.
- 2) Test conditions: inlet air density at 0.075lbs. per cubic foot. (20°C(68°F), 29.92 in. Hg(14.7PSIA)).
- 3) Normal performance variations on the resistance curve within +/- 10% of supplied data can be expected.
- 4) Specifications subject to change without notice.
- 5) All performance at 60Hz operation.

Wiring Diagrams for Regenerative Blowers

Models R1102, R2103, R3105-1, R4110-2, R5125-2, R6125-2

Low Voltage Single Phase

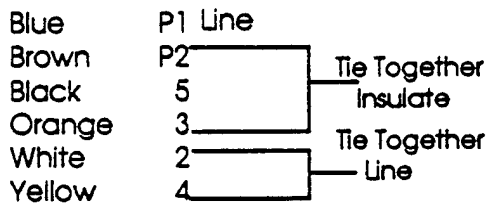

High Voltage Single Phase

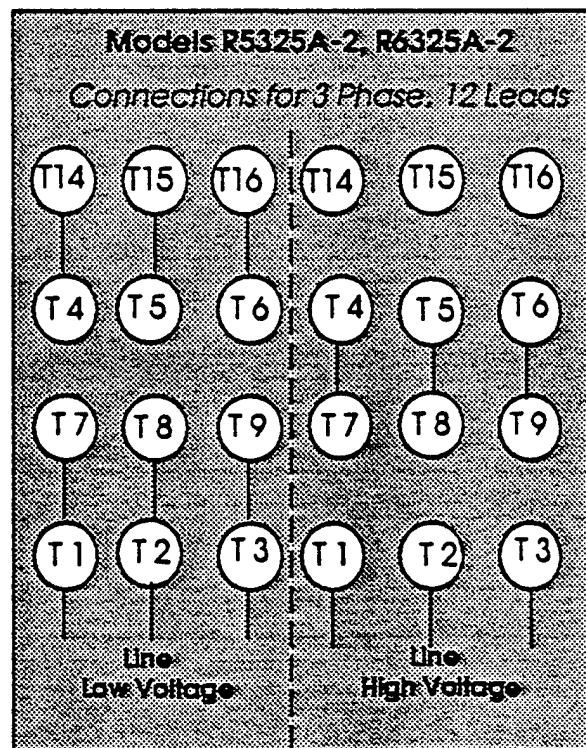
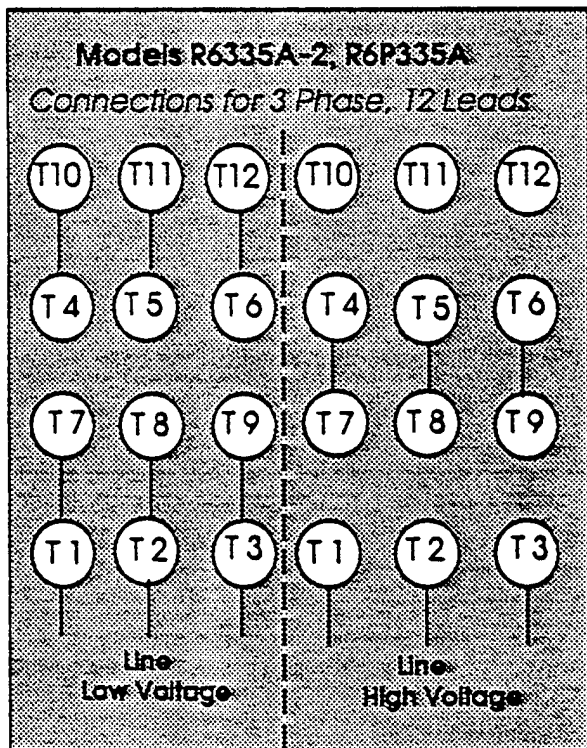
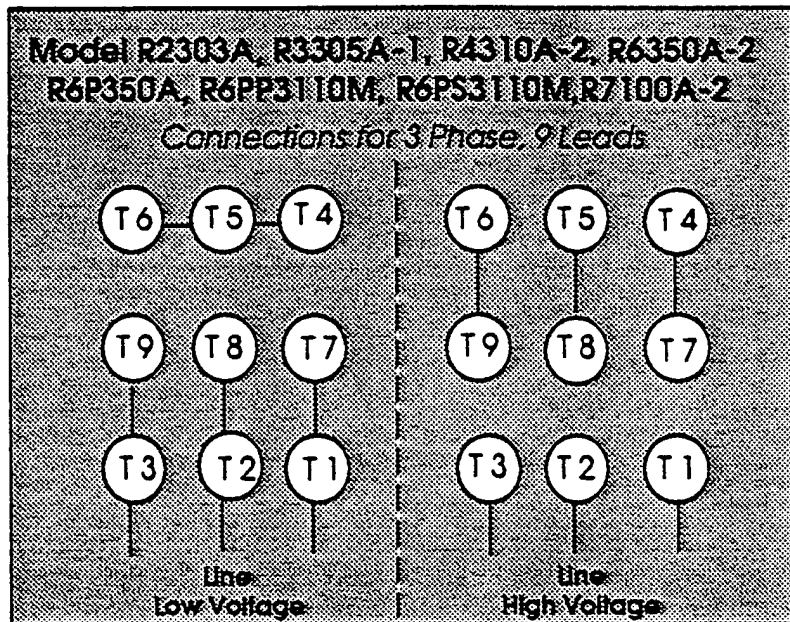
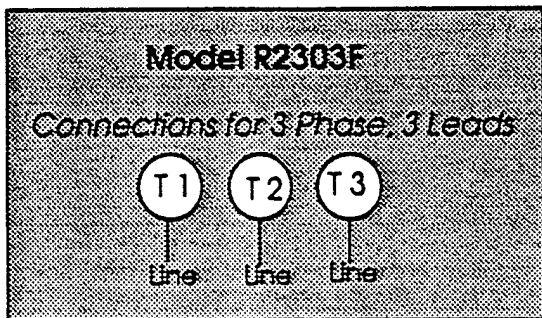
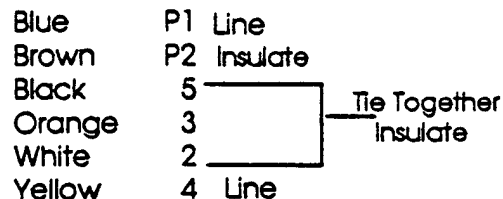

To reverse rotation on any three phase motor, interchange any two external motor line connections to any two line leads.

Safety

- ⚠ This is the safety alert symbol. When you see this symbol, personal injury is possible. The degree of injury is shown by the following signal words:
- ⚠ **DANGER:** Severe injury or death will occur if hazard is ignored.
 - ⚠ **WARNING:** Severe injury or death can occur if hazard is ignored.
 - ⚠ **CAUTION:** Minor injury or property damage can occur if hazard is ignored.

Review the following information carefully before operating.

General Information

- ⚠ **DANGER:** Do not pump flammable or explosive gases or operate in an atmosphere containing them. Ambient temperature for normal operation should not exceed 40 degrees C (105 degrees F). For higher ambient operation, consult the factory. Blower performance is reduced by the lower atmospheric pressure of high altitudes. If it applies to this unit, consult a Gast distributor or the factory for details.

Installation

- ⚠ **WARNING:** Electric Shock can result from bad wiring. Wiring must conform to all required safety codes and be installed by a qualified person. Grounding is required.

The Gast Regenair blower can be installed in any position. The flow of cooling air over the blower and motor must not be blocked.

PLUMBING - The threaded pipe ports are designed as connection ports only and will not support the plumbing. Be sure to use the same or larger size pipe and fittings to prevent air flow restriction and over-heating of the blower. When installing plumbing, be sure to use a small amount of pipe thread lubricant. This protects the threads in the aluminum blower housing. Dirt and chips, often found in new plumbing, should not be allowed to enter the blower.

NOISE - To reduce noise and vibration, the unit should be mounted on a solid surface that will not increase sound. The use of shock mounts or vibration isolation material is recommended. If needed, inlet or discharge noise can be reduced by attaching muffler assemblies (see accessories).

ROTATION - The Gast Regenair blower should only rotate clockwise as viewed from the electric motor side. This is marked with an arrow in the casting. Proper rotation can be confirmed by checking air flow at the IN and OUT ports. On blowers powered by a three phase motor, rotation is reversed by changing any two of the three power wires.

Operation

- ⚠ **WARNING:** Solid or liquid material exiting the blower or piping can cause eye damage or skin cuts. Keep away from air stream.
- ⚠ **CAUTION:** Attach blower to solid surface before starting. Prevent injury or damage from unit movement. Air containing solid particles or liquid must pass through a filter before entering the blower (see accessories list for filter suggestions). Blowers must have mufflers, filters, other accessories and all piping attached before starting. Any foreign material passing through the blower may cause internal damage.
- ⚠ **CAUTION:** Outlet piping can burn skin. Guard or limit access. Mark "CAUTION Hot surface. Can cause burns." Air temperature increases when passing through the blower. When run at duties above 50 in. H₂O, metal pipe may be required for hot exhaust air.

The blower must not be operated above the limits for continuous duty. "Standard" R1, R2, R3 and R4 can operate continuously with not air flowing through the blower. Other units can only be run at the rating shown on the model number label. Do not close off inlet (for vacuum) or exhaust (for pressure) to reduce extra air flow. This could cause added heat and motor load.

ACCESSORIES - Gast pressure gauges AJ496 or AE133 and vacuum gauges AJ497 or AE134 show blower duty. The Gast pressure/vacuum relief valve, AG258, will limit the operating duty by admitting or relieving air. It also allows full flow through the blower when the relief valve closes.

Servicing

- ⚠ **WARNING:** Disconnect electric power before servicing. Be sure rotating parts have stopped. Electric shock or severe cuts can result. Inlet and exhaust filters need occasional cleaning or replacement of the elements. Failure to do so will result in more pressure drop, reduced air flow and hotter operation. The outside of the unit requires cleaning of dust and dirt. The inside of the blower also may need cleaning to remove material coating the impeller and housing. If not done, the buildup can cause vibration, hotter operation and reduced flow. Noise absorbing foam in the mufflers may need replacement.
- KEEP THIS INFORMATION WITH THE BLOWER. REFER TO IT FOR SAFE INSTALLATION, OPERATION OR SERVICE.**

| TROUBLESHOOTING | | |
|------------------------|---|--|
| <i>Symptom:</i> | <i>Possible Diagnosis:</i> | <i>Possible Remedy:</i> |
| Excess Vibration | Impeller damaged by foreign material Impeller contaminated by foreign material | Replace impeller Clean impeller, install adequate filtration. |
| Abnormal sound | Motor bearing failed Impeller rubbing against cover or housing | Replace bearings Repair blower, check clearances. |
| Increase in sound | Foreign material can coat or destroy muffler foam. | Replace foam muffler elements, trap or filter foreign material. |
| Blown fuse | Electrical wiring problem | Have qualified person check fuse capacity and wiring. |
| Unit very hot | Running at too high a pressure or vacuum | Install a relief valve. |

REGENAIR ACCESSORIES

Inline Filters (for vacuum)

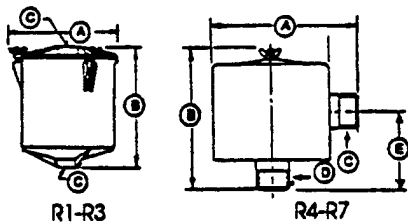

| Model Number | R1 & R2 | R3 | R4, R5 &SDR4 | R6P SDR5, SDR6 R6PP, R6PS | R7 |
|---------------------|---------|------------|--------------|---------------------------|--------|
| Part # | AV460 | AV460C | AG337 | AJ151G | AJ151H |
| Dim A | 8.25" | 8.25" | 11.75" | 8.00" | 16.25" |
| Dim B | 8.875" | 8.875" | 4.75" | 10.25" | 27.13" |
| Dim C | 1" FPT | 1 1/4" FPT | 1 1/2" MPT | 2 1/2" MPT | 3" MPT |
| Dim D | - | - | 1 1/2" FPT | 2 1/2" MPT | 3" MPT |
| Dim E | - | - | 2.38 | 5.50 | 18.50 |
| Replacement Element | AV469 | AV469 | AG340 | AJ135G | AJ135C |
| Micron | 10 | 10 | 25 | 10 | 10 |

MPT = Male Pipe Thread
FPT = Female Pipe Thread

Inlet Filters (for pressure units only)

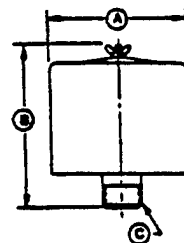

| Model Number | R1 & R2 | R3 | R4, R5 &SDR4 | R6, SDR5 SDR6, R6P R6PP, R6PS | R7 |
|---------------------|---------|------------|--------------|-------------------------------|------------|
| Part # | AJ126B | AJ126C | AG338 | AJ126F | AJ126G |
| Dim A | 6.00" | 6.00" | 10.63" | 10.63" | 10.00" |
| Dim B | 4.62** | 7.12** | 4.81** | 4.81** | 13.12** |
| Dim C | 1" MPT | 1 1/4" MPT | 1 1/2" FPT | 2" FPT | 2 1/2" MPT |
| Replacement Element | AJ134B | AJ134C | AG340 | AG340 | AJ135A |
| Micron | 10 | 10 | 25 | 25 | 10 |

All are heavy duty for high amounts of particulates. Inlet filters for REGENAIR blowers are drip-proof when mounted as shown.

Mufflers

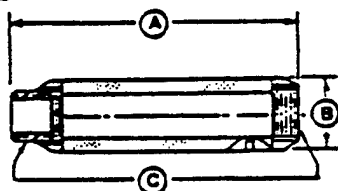

| Model Number | R2 | R3 | R4, R5 SDR 4" &SDR5" | R6, SDR6" R6P R6PP, R6PS | R7 |
|--------------|--------|------------|----------------------|--------------------------|------------|
| Part # | AJ121B | AJ121C | AJ121D | AJ121E | AJ121G |
| Dim. A | 7.46** | 7.94** | 12.75** | 17.05** | 17.44** |
| Dim. B | 2.38" | 2.62" | 3.25" | 3.63" | 4.25" |
| Dim. C | 1" NPT | 1 1/4" NPT | 1 1/2" NPT | 2" NPT | 2 1/2" NPT |

For Inlet Only
* Approximately

Pressure-Vacuum Gauge



Pressure Gauge, Part #AJ496, 2 5/8" Diameter, 1/4" NPT, 0-60 inches H₂O and 0-150 mbar

Pressure Gauge, Part #AE133A, 2 5/8" Diameter, 1/4" NPT, 0-200 inches H₂O and 0-500 mbar

Vacuum Gauge, Part #AJ497, 2 5/8" Diameter, 1/4" NPT, 0-60 inches H₂O and 0-150 mbar

Vacuum Gauge, Part #AE134, 2 5/8" Diameter, 1/4" NPT, 0-160 inches H₂O and 0-400 mbar

Fittings

| Pipe Size | 1" | 1 1/4" | 1 1/2" | 2" | 2 1/2" |
|-----------------------------|--------|--------|--------|--------|--------|
| Tee | BA415 | BA431 | BA432 | BA433 | BA434 |
| Common Elbow | BA220 | BA244 | BA230 | BA247 | BA248 |
| Nipple | BA752 | BA809 | BA783 | BA810 | BA813 |
| Plastic Male Pipe Hose Barb | AJ117A | AJ117B | - | - | - |
| Hose I.D. | 1.25 | 1.25 | - | - | - |
| Metal Male Pipe Hose Barb | AJ117D | AJ117F | AJ117C | AJ117G | AJ117H |
| Hose I.D. | 1.00 | 1.25 | 1.50 | 2.50 | 3.00 |

Relief Valve

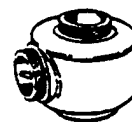

Pressure/Vacuum Relief Valve, Part #AG258, 1 1/2" NPT, Adjustable 30-170 inches H₂O, 200 CFM maximum

Silencer for Relief Valve, Part #AJ121D

Horizontal Swing Type Check Valve

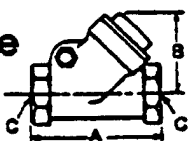

| Model Number | R1, R2 | R3 | R4, R5 SDR 4" &SDR5" | R6, SDR6" R6P R6PP, R6PS | R7 |
|--------------|--------|------------|----------------------|--------------------------|------------|
| Part # | AH326B | AH326C | AH326D | AH326E | AH326G |
| Dim. A | 3.57 | 4.19 | 4.50 | 5.25 | 8 |
| Dim. B | 2.32 | 2.69 | 2.94 | 3.82 | 5.07 |
| Dim. C | 1" NPT | 1 1/4" NPT | 1 1/2" NPT | 2" NPT | 2 1/2" NPT |

BOREHOLE NUMBER: 6 (VMP-1)

| | |
|------------------------------|--------------------------------------|
| PROJECT NUMBER: DE 268.20.04 | PROJECT NAME: BIODVENTING INITIATIVE |
| CLIENT: AFCEE | DRILLER: PC EXPLORATION |
| LOCATION: BEALE AFB, CA | DRILLING METHOD: HOLLOW-STEM AUGER |
| IRP SITE 3: FPTA No. 1 | |
| GEOLOGIST: HENRY PIETROPADLI | HOLE DIAMETER: 11" |
| COMPLETION DATE: | TOTAL DEPTH: 25.6' BGS |

| DEPTH feet | SAMPLE LOCATION | SAMPLE NUMBER | BLOW COUNT | PID (ppm) (TNTVA) (PPEM) | GRAPHIC LOG | SOIL CLASS | GEOLOGIC DESCRIPTION |
|--|-----------------|---------------|------------|--------------------------|-------------|------------|--|
| 0-5 | | | | | | | CLAY: silty, sm clay silt, red-brn, dry, dense. |
| 5-10 | | BE3-VMP1-9 | 22/50 | 281 (190) | | | CLAY: silty, blue-grn discoloration, mod stiff, plastic, fuel/paint odor |
| 10-15 | | | 17/21/30 | 285 (160) | | | SAND: med grnd, lgt grn-brn, silty, mod sort, loose, damp, paint odor. |
| 15-20 | | | 18/28/50 | 32 (13) | | | CLAY: sm silty clay, lgt brn, black inclusions, abundant Fe-staining, damp, mod stiff; minor zones of fn sd. |
| 20-25 | | | 22/15/50 | 10 (7) | | | CLAY: lgt tan, abundant black inclusions, abundant Fe staining. |
| <p>#6 TOTAL DEPTH: 25.6' BGS. VAPOR MONITORING POINT BOREHOLE (COMPLETED) AS A BOREHOLE (VMP-1).</p> <p>#6A TOTAL DEPTH: 8.5' BGS - backfilled.</p> | | | | | | | |

- Equilibrated waterlevel.
- First encountered groundwater.
- Brass tube sample submitted for laboratory analysis

BOREHOLE NUMBER: 7 (JMP-4)

| | |
|---|-------------------------------------|
| PROJECT NUMBER: DE 268.20.04 | PROJECT NAME: BIOVENTING INITIATIVE |
| CLIENT: AFCEE | DRILLER: PC EXPLORATION |
| LOCATION: BEALE AFB, CA IRP SITE 3 : FPTA No.1 | DRILLING METHOD: HOLLOW-STEM AUGER |
| GEOLOGIST: HENRY PIETROPADLI | HOLE DIAMETER: 8" |
| COMPLETION DATE: | TOTAL DEPTH: 29.0' BGS |

| DEPTH feet | SAMPLE LOCATION | SAMPLE NUMBER | BLOW COUNT | PID (ppm) (TWA) (ppm) | GRAPHIC LOG | SOIL CLASS | GEOLOGIC DESCRIPTION |
|---------------|-----------------|---------------|------------|--------------------------|-------------|------------|---|
| 5 | | | NR | 4 (0) | | | CLAY: silty, lgt yel-brn, damp, sli plastic, mod stiff, occ gravel. |
| 10 | | | 17/28/50 | 0 (0) | | | CLAY: silty, red-brn, damp, sli plastic, stiff, abundant black spots. |
| 15 | | | 50 | 17 (0) | | | CLAY: silty, sm clay, silt, lgt yel-brn, damp, sli plastic, mod stiff, abund black spots, Fe-staining. SAND: Fine grd, clayey, silty, lgt yel, grn-brn, hard, damp to dry, abund black spots, Fe-staining. |
| 20 | | | 26/50 | 9 (0) | | | CLAY: silty, lgt gry-brn, abund black spots, damp, sli plastic, mod stiff. |
| 25 | | | 26/50 | 16 (0) | | | CLAY: silty, dk red-brn, damp, mod stiff, abund Fe-staining, abund black patches, sli plastic. |
| 30 | | | 50 | 14 (0) | | | GRAVEL: coarse, sandy, clasts up to 2", moist, loose - med dns, poorly sorted. TOTAL DEPTH 29.0' BGS. BACKFILLED TO 25.0' BGS w/BENTONITE. BOREHOLE CONSTRUCTED AS A VAPOR MONITORING POINT (JMP-4). |

- ▼ - Equilibrated waterlevel.
- ▽ - First encountered groundwater.

■ - Brass tube sample submitted for laboratory analysis

BOREHOLE NUMBER: 1 (VMP-2)

| | |
|-------------------------------------|-------------------------------------|
| PROJECT NUMBER: DE 268.20.04 | PROJECT NAME: BIOVENTING INITIATIVE |
| CLIENT: AFCEE | DRILLER: PC EXPLORATION |
| LOCATION: BEALE AFB, CA | DRILLING METHOD: HOLLOW-STEM AUGER |
| IRP SITE 18: BULK FUEL STORAGE AREA | |
| GEOLOGIST: HENRY PIETROPAOLI | HOLE DIAMETER: 8" |
| COMPLETION DATE: 11/06/92 | TOTAL DEPTH: 67.5' BGS |

| DEPTH feet | SAMPLE LOCATION | SAMPLE NUMBER | BLOW COUNT | PID (ppm) | GRAPHIC LOG | SOIL CLASS | GEOLOGIC DESCRIPTION |
|---------------|-----------------|---------------|------------|-------------|-------------|------------|--|
| 0-5 | | | | | | | GRAVEL: railroad ballast material within dk brn silty clay matrix, moist, stiff, plastic. |
| 5-10 | | | NR | 267 | | | SILT: clayey, grn-brn, damp, Fe staining, dense, damp, fuel odor. Grades into discolored (blue-grn) fn sand. |
| 10-15 | BE18-YW-11 | | 20/50 | 580 1127 | | | SAND: clayey, fn grd, blue-green discoloration, brown, silty plastic, damp, loose, fuel odor. |
| 15-20 | | | 50/50 | 0 | | | CLAY: lgt tan, dense, plastic |
| 20-25 | | | 12/17/29 | 349 | | | CLAY: lgt red-brn, plastic, stiff, damp, black patches. |
| 25-30 | | | 32/27/50 | 78 | | | CLAY: red-brn, med sandy, silty plastic, damp, mod stiff abund Fe staining, abund blk patches. |
| 30-35 | | | NR | 0 | | | CLAY: lgt tan, damp, stiff, silty plastic, abund blk patches. |

▼ - Equilibrated waterlevel.

■ - Brass tube sample submitted for laboratory analysis

▽ - First encountered groundwater.

BOREHOLE NUMBER: 1 (VMP-2)

| | |
|-------------------------------------|---------------------------------------|
| PROJECT NUMBER: DE 268.20.04 | PROJECT NAME: BIODIVERTING INITIATIVE |
| CLIENT: AFCEE | DRILLER: PC EXPLORATION |
| LOCATION: BEALE AFB, CA | DRILLING METHOD: HOLLOW-STEM AUGER |
| IRP SITE 18: BULK FUEL STORAGE AREA | |
| GEOLOGIST: HENRY PIETROPAOLI | HOLE DIAMETER: 8" |
| COMPLETION DATE: 11/06/92 | TOTAL DEPTH: 67.5' BGS |

| DEPTH feet | SAMPLE LOCATION | SAMPLE NUMBER | BLOW COUNT | PID (ppm) | GRAPHIC LOG | SOIL CLASS | GEOLOGIC DESCRIPTION |
|---------------|-----------------|---------------|------------|-----------|-------------|------------|--|
| 35 | | | 22/35/50 | 0 | | | CLAYEY SILT/ CLAY: silty (sm clayey silt), damp, sl: plastic, mod stiff, occ coarse sd. |
| 40 | | | 30/50 | 802 | | | as above. |
| 45 | | | 14/50 | 148 | | | SAND: red-brn, coarse-med, gravelly, moist, loose, rounded and angular. |
| 50 | | | 10/24/50 | 136 | | | CLAY: silty, red-brn, damp, plastic, stiff. |
| 55 | | | 40/50 | 743 | | | CLAY: silty, lgt red-brn, damp, stiff, sl: plastic, abund blk patches, white (caliche-like) streaks. |
| 60 | | | 22/35/50 | 112 | | | as above. |

▼ - Equilibrated waterlevel.

▽ - First encountered groundwater.

■ - Brass tube sample submitted for laboratory analysis

BOREHOLE NUMBER: 1 (VMP-2)

| | |
|-------------------------------------|-------------------------------------|
| PROJECT NUMBER: DE 268.20.04 | PROJECT NAME: BIOVENTING INITIATIVE |
| CLIENT: AFCEE | DRILLER: PC EXPLORATION |
| LOCATION: BEALE AFB, CA | DRILLING METHOD: HOLLOW-STEM AUGER |
| IRP SITE 18: BULK FUEL STORAGE AREA | |
| GEOLOGIST: HENRY PIETROPAOLI | HOLE DIAMETER: 8" |
| COMPLETION DATE: 11/06/92 | TOTAL DEPTH: 67.5' BGS |

| DEPTH feet | SAMPLE LOCATION | SAMPLE NUMBER | BLOW COUNT | PID (ppm) | GRAPHIC LOG | SOIL CLASS | GEOLOGIC DESCRIPTION |
|---------------|-----------------|---------------|----------------------|-----------|-------------|------------|---|
| | | | 21 35 50 | 112 | | | as above. |
| 65 | | | 10 28 36 50 | 246 NR | | | SILT: lgt grn-yel, red-brn, clayey, mottled, damp, sl: plastic, mod stiff, abund blk patches. |
| | | | | | | | TOTAL DEPTH: 67.5' bgs. Borehole completed as a Vapor Monitoring Point (VMP-2). |

▼ - Equilibrated waterlevel.

■ - Brass tube sample submitted for laboratory analysis

▽ - First encountered groundwater.

BOREHOLE NUMBER: 2 (VW-1)

| | |
|-------------------------------------|-------------------------------------|
| PROJECT NUMBER: DE 268.20.04 | PROJECT NAME: BIODENTING INITIATIVE |
| CLIENT: AFCEE | DRILLER: PC EXPLORATION |
| LOCATION: BEALE AFB, CA | DRILLING METHOD: HOLLOW-STEM AUGER |
| IRP SITE 18: BULK FUEL STORAGE AREA | |
| GEOLOGIST: HENRY PIETROPAOLI | HOLE DIAMETER: 11" |
| COMPLETION DATE: 11/03/92 | TOTAL DEPTH: 71.5 FT BGS |

| DEPTH feet | SAMPLE LOCATION | SAMPLE NUMBER | BLOW COUNT | PID (ppm) | GRAPHIC LOG | SOIL CLASS | GEOLOGIC DESCRIPTION |
|---------------|-----------------|------------------|------------------------------|--------------|-------------|------------|---|
| 5 | | | 6/12 13 | 793 | | | CLAY: dk brn, damp, plastic, soft w/gravel (1"-2"). |
| 10 | | BE18- VW1-11 | 9/10 13 10 12 17 | 2753 628 | | | SILT: clayey w/fine sd, discolored blue-green, sli plastic, soft, damp, fuel odor. |
| 15 | | | 17/31 50 | 306 | | | SAND: fine to med, grn-brn, loose, damp, fuel odor. |
| 20 | | | 8/18 32 | 189 | | | CLAY: silty, discolored blue-green, fuel odor. |
| 25 | | | 18/25 32 | 227 | | | CLAY: silty, red-brn, abundant black spots and streaks of blue-green discoloration, mod stiff, damp, sli plastic. |
| | | | | | | | CLAY: red-brn, plastic, damp, soft. |
| | | | | | | | CLAY: red-brn to light tan, sli plastic, damp, stiff, abundant blue-green discoloration. |

▼ - Equilibrated waterlevel.

■ - Brass tube sample submitted for laboratory analysis

▽ - First encountered groundwater.

BOREHOLE NUMBER: 2 (VW-1)

| | |
|-------------------------------------|------------------------------------|
| PROJECT NUMBER: DE 268.20.04 | PROJECT NAME: BIDENTING INITIATIVE |
| CLIENT: AFLEE | DRILLER: PC EXPLORATION |
| LOCATION: BEALE AFB, CA | DRILLING METHOD: HOLLOW-STEM AUGER |
| IRP SITE 18: BULK FUEL STORAGE AREA | |
| GEOLOGIST: HENRY PIETROPAOLI | HOLE DIAMETER: 11" |
| COMPLETION DATE: 11/03/92 | TOTAL DEPTH: 71.5' BGS |

| DEPTH feet | SAMPLE LOCATION | SAMPLE NUMBER | BLOW COUNT | PID (ppm) | GRAPHIC LOG | SOIL CLASS | GEOLOGIC DESCRIPTION |
|---------------|-----------------|------------------|---------------|-----------|-------------|------------|--|
| 35 | | | 50/50 | 235 | | | CLAY: silty, lgt tan, damp, soft, mod stiff, sli plastic. |
| 40 | | | 28/42/50 | 249 | | | SAND: fine to med, red-brn, micaceous, mod-well sort, loose, damp, minor clay. |
| 45 | | | 38/50 | 430 | | | CLAY: lgt tan, stiff, abundant black spots, damp, sli plastic. |
| 50 | | | 18/29/37 | 269 | | | CLAY: silty, red-brn, abundant black spots, sli plastic, damp, mod stiff. |
| 55 | | | 18/52 | 282 | | | CLAY: as above |
| 60 | | | 29/50 | 407 | | | CLAY: as above |

▼ - Equilibrated waterlevel.

■ - Brass tube sample submitted for laboratory analysis

▽ - First encountered groundwater.

BOREHOLE NUMBER: 2 (VW-1)

| | |
|-------------------------------------|------------------------------------|
| PROJECT NUMBER: DE 268.20.04 | PROJECT NAME: BIVENTING INITIATIVE |
| CLIENT: AFCEE | DRILLER: PC EXPLORATION |
| LOCATION: BEALE AFB, CA | DRILLING METHOD: HOLLOW-STEM AUGER |
| IRP SITE 18: BULK FUEL STORAGE AREA | |
| GEOLOGIST: HENRY PIETROPADLI | HOLE DIAMETER: 11" |
| COMPLETION DATE: 11/03/92 | TOTAL DEPTH: 71.5' BGS |

| DEPTH feet | SAMPLE LOCATION | SAMPLE NUMBER | BLOW COUNT | PID (ppm) | GRAPHIC LOG | SOIL CLASS | GEOLOGIC DESCRIPTION |
|---------------|-----------------|------------------|----------------|--------------|-------------|------------|--|
| | | | 29 50 | 407 | — | — | CLAY: as above. |
| 65 | | | 17 20 48 | 71 | — | — | CLAY: as above, with occ gravel |
| 70 | | | 30 50 | 25 | — | — | SAND: reddish-brn, loose, damp, med- well sorted, occ rounded gravel. |
| | | | | | | | TOTAL DEPTH: 71.5' bgs. Borehole backfilled with bentonite to 60' bgs; completed as a vent well (VW-1). |

- ▼ - Equilibrated waterlevel.
- ▼ - First encountered groundwater.
- - Brass tube sample submitted for laboratory analysis

BOREHOLE NUMBER: 3 (VMP-1)

| | |
|-------------------------------------|--------------------------------------|
| PROJECT NUMBER: DE 268.20.04 | PROJECT NAME: BIODVENTING INITIATIVE |
| CLIENT: AFCEE | DRILLER: PC EXPLORATION |
| LOCATION: BEALE AFB, CA | DRILLING METHOD: HOLLOW-STEM AUGER |
| IRP SITE 18: BULK FUEL STORAGE AREA | |
| GEOLOGIST: HENRY PIETROPAOLI | HOLE DIAMETER: 8" |
| COMPLETION DATE: 11/05/92 | TOTAL DEPTH: 70.0 FT BGS |

| DEPTH feet | SAMPLE LOCATION | SAMPLE NUMBER | BLOW COUNT | PID (ppm) | GRAPHIC LOG | SOIL CLASS | GEOLOGIC DESCRIPTION |
|---------------|-----------------|-------------------------|------------------|-----------|-------------|------------|--|
| 5 | | | 20/ 31/ 50 | 963 | | | GRAVEL: Railroad ballast material within dk brn clay matrix, v guly @ 4', clay is damp, plastic, mod stiff. |
| 10 | | | 40/ 50 | 1640 | | | SILT: clayey, blue-green discoloration, iron staining, damp, sli plastic, fuel odor. |
| 15 | | BE-18- vmp1- 12.5 | 29/ 50 | 1700 | | | SAND: fn to med, blue-green discoloration, clayey, loose, damp, fuel odor. SAND: med, red-brn. |
| 15 | | | 17/ 18/ 20 | 257 | | | SAND: mod-well sort, blue-grn discoloration |
| 20 | | | 17/ 19/ 30 | 411 | | | CLAY: silty, lgt red-brn, damp, stiff. 4-in. coarse sdy zone @ 18 FT. |
| 25 | | | 13/ 16/ 22 | 366 | | | CLAY: as above w/ more abundant blk patches. |
| 30 | | | 31/ 50 | 1530 | | | CLAY: lgt red-brn, silty, mod stiff, sli plastic, damp, some blue-grn discoloration, sli abundant blk patches. |

▼ - Equilibrated waterlevel.

■ - Brass tube sample submitted for laboratory analysis

▽ - First encountered groundwater.

BOREHOLE NUMBER: 3 (VMP-1)

| | |
|-------------------------------------|-------------------------------------|
| PROJECT NUMBER: DE 268.20.04 | PROJECT NAME: BIOVENTING INITIATIVE |
| CLIENT: AFCEE | DRILLER: PC EXPLORATION |
| LOCATION: BEALE AFB, CA | DRILLING METHOD: HOLLOW-STEM AUGER |
| IRP SITE 18: BULK FUEL STORAGE AREA | |
| GEOLOGIST: HENRY PIETROPAOLI | HOLE DIAMETER: 8" |
| COMPLETION DATE: 11/05/92 | TOTAL DEPTH: 70.0 FT BGS |

| DEPTH feet | SAMPLE LOCATION | SAMPLE NUMBER | BLOW COUNT | PID (ppm) | GRAPHIC LOG | SOIL CLASS | GEOLOGIC DESCRIPTION |
|---------------|-----------------|---------------|------------|-----------|-------------|------------|---|
| | | | | | | | SILT: sdy (fn-med), damp, hard, dense, white (caliche-like) streaks. |
| 35 | | | 50 | 215 | | | CLAY: slty, lgt tan, damp, stiff, sli plast., abund Fe stain, abndt black patches. |
| 40 | | | 21/22/26 | 324 | | | CLAY: slty, red-brn, sli plast, damp, mod stiff to soft, occ black patches. |
| 45 | | | 23/27/38 | 267 | | | SAND: fn grd, silty, red-brn, med dnse, damp. Grades to sand w/abundant mica, loose, mod-well sort gravel at base. |
| 50 | | | 31/50 | 544 | | | CLAY: slty, lgt yellow, damp, sli plastic, abund black patches, mod stiff. Grades into red-brn, occ. white patches, abundant black patches. |
| 55 | | | 21/32/50 | 509 | | | CLAY: As above, with white (caliche-like) streaks at 57'. |
| 60 | | | 15/17/50 | 676 | | | CLAY: slty/fn sdy, red-brn, sli plastic, damp, stiff, abund black patches, occ grn-white patches |

▼ - Equilibrated waterlevel.

■ - Brass tube sample submitted for laboratory analysis

▽ - First encountered groundwater.

BOREHOLE NUMBER: 3 (VMP-1)

| | |
|------------------------------------|-------------------------------------|
| PROJECT NUMBER: DE268.20.04 | PROJECT NAME: BIOVENTING INITIATIVE |
| CLIENT: AFCEE | DRILLER: FC EXPLORATION |
| LOCATION: BEALE AFB, CA | DRILLING METHOD: HOLLOW-STEM AUGER |
| IRPSITE 18: BULK FUEL STORAGE AREA | |
| GEOLOGIST: HENRY PIETROPADLI | HOLE DIAMETER: 8" |
| COMPLETION DATE: 11/05/92 | TOTAL DEPTH: 70.0 FT BGS |

| DEPTH feet | SAMPLE LOCATION | SAMPLE NUMBER | BLOW COUNT | PID (ppm) | GRAPHIC LOG | SOIL CLASS | GEOLOGIC DESCRIPTION |
|---------------|-----------------|------------------|------------------|-----------|----------------------------------|------------|--|
| 65 | | | 19/ 23/ 50 | 489 | [Hand-drawn soil profile sketch] | | CLAY/CLAYEY SILT: mottled green-brown, occ white patches. |
| 70 | | | 27/ 50 | 218 | [Hand-drawn soil profile sketch] | | CLAY/CLAYEY SILT: As above. |
| | | | | | | | TOTAL DEPTH: 70.0' bgs. Borehole completed as a Vapor Monitoring Point (VMP-1) |

- ▼ - Equilibrated waterlevel.
- ▼ - First encountered groundwater.
- - Brass tube sample submitted for laboratory analysis

BOREHOLE NUMBER: 4 (VMP-3)

| | |
|-------------------------------------|-------------------------------------|
| PROJECT NUMBER: DE 268.20.04 | PROJECT NAME: BIOVENTING INITIATIVE |
| CLIENT: AFCEE | DRILLER: PC EXPLORATION |
| LOCATION: BEALE AFB, CA | DRILLING METHOD: HOLLOW-STEM AUGER |
| IRP SITE 18: BULK FUEL STORAGE AREA | |
| GEOLOGIST: HENRY PIETRO PAOLI | HOLE DIAMETER: 8" |
| COMPLETION DATE: 11/10/92 | TOTAL DEPTH: 68.0' BGS |

| DEPTH feet | SAMPLE LOCATION | SAMPLE NUMBER | BLOW COUNT | PID (ppm) | GRAPHIC LOG | SOIL CLASS | GEOLOGIC DESCRIPTION |
|------------|-----------------|---------------|------------|-----------|-------------|------------|--|
| 5 | | | 5/10/14 | 610 | | GRAVEL | GRAVEL: railroad ballast material within dk brn silty clay matrix; matrix is damp/stiff/plastic, fuel odor |
| 10 | | | 12/28/50 | 387 | | SAND | SILT: clayey, blue-green (discoloration), silty plastic, damp, stiff, fuel odor. Grades downward to sand. SAND: clayey, red-brn, frgrd, loose |
| 15 | | | 16/16/50 | 684 | | CLAY | CLAY: silty, red-brn w/blue-green discoloration, damp, silty plastic, mod stiff, fuel odor. CLAY: as above w/ 1"-2" lenses of loose, fine clayey sand. Fuel odor. |
| 20 | | | 7/14/30 | 366 | | CLAY | CLAY: silty, lgt brn, stiff, damp, silty plastic, abundant Fe-staining. With wet clayey SILT, loose. |
| 25 | | | 20/37/50 | 278 | | CLAY | CLAY: silty, red-brn, stiff, damp, silty plastic. |
| 30 | | | 50/ | 212 | | CLAY | CLAY: silty, lgt brn, abund black patches, abundant Fe-staining, damp, stiff, silty plastic. |

- Equilibrated waterlevel.
- First encountered groundwater.
- Brass tube sample submitted for laboratory analysis

BOREHOLE NUMBER: 4 (VMP-3)

| | |
|-------------------------------------|-------------------------------------|
| PROJECT NUMBER: DE 268.20.04 | PROJECT NAME: BIOVENTING INITIATIVE |
| CLIENT: AFCEE | DRILLER: PC EXPLORATION |
| LOCATION: BEALE AFB, CA | DRILLING METHOD: HOLLOW-STEM AUGER |
| IRP SITE 18: BULK FUEL STORAGE AREA | |
| GEOLOGIST: HENRY PIETROPAOLI | HOLE DIAMETER: 8" |
| COMPLETION DATE: 11/10/92 | TOTAL DEPTH: 68.0' BGS |

| DEPTH feet | SAMPLE LOCATION | SAMPLE NUMBER | BLOW COUNT | PID (ppm) | GRAPHIC LOG | SOIL CLASS | GEOLOGIC DESCRIPTION |
|------------|-----------------|---------------|------------|-----------|--------------------------|------------|--|
| 35 | | | 50/17/50 | 212 | [Hand-drawn log symbols] | | CLAY: as above, without black patches. |
| 40 | | | 17/34/50 | 379 | [Hand-drawn log symbols] | | CLAY: as above; color change at 40' - above is brn, below is red-brn. |
| 45 | | | 14/27/50 | 802 | [Hand-drawn log symbols] | | CLAY: as above. |
| 50 | | | 8/17/25 | 303 | [Hand-drawn log symbols] | | CLAY: silty, lgt reddish-grn-brn, mottled, w/occ. fine sand zones, damp, sli. plastic, mod. stiff. |
| 55 | | BE18-VMP3-55 | 7/11/17 | 1165 | [Hand-drawn log symbols] | | CLAY: as above. |
| 60 | | | 7/14/40 | 86 | [Hand-drawn log symbols] | | CLAY: silty, mottled red/grn-brn occ med sand, sli. plastic damp, stiff, abund black patches and white (caliche-like) streaks. |

- ▼ - Equilibrated waterlevel.
- ▼ - First encountered groundwater.
- - Brass tube sample submitted for laboratory analysis

BOREHOLE NUMBER: 4 (VMP-3)

| | |
|-------------------------------------|-------------------------------------|
| PROJECT NUMBER: DE 268.20.04 | PROJECT NAME: BIOVENTING INITIATIVE |
| CLIENT: AFCEE | DRILLER: PC EXPLORATION |
| LOCATION: BEALE AFB, CA | DRILLING METHOD: HOLLOW-STEM AUGER |
| IRP SITE 18: BULK FUEL STORAGE AREA | |
| GEOLOGIST: HENRY PIETROPAOLI | HOLE DIAMETER: 8" |
| COMPLETION DATE: 11/10/92 | TOTAL DEPTH: 68.0' BGS |

| DEPTH feet | SAMPLE LOCATION | SAMPLE NUMBER | BLOW COUNT | PID (ppm) | GRAPHIC LOG | SOIL CLASS | GEOLOGIC DESCRIPTION |
|---------------|-----------------|---------------|--------------|-----------|-------------|------------|---|
| | | | 7 1/4 / 40 | 86 | | | |
| 65 | | | 17 / 27 / 50 | 32 | | | CLAY: as above. TOTAL DEPTH: 68.0' bgs Borehole completed as a Vapor Monitoring Point (VMP-3). |

▼ - Equilibrated waterlevel.

▽ - First encountered groundwater.

■ - Brass tube sample submitted for laboratory analysis

APPENDIX B

O & M MANUAL AND DATA COLLECTION SHEET

**REGENERATIVE BLOWER
OPERATIONS AND MAINTENANCE MANUAL
FOR
EXTENDED TESTING SYSTEM**

Prepared for:

**AIR FORCE CENTER FOR ENVIRONMENTAL EXCELLENCE
BROOKS AFB, TEXAS**

USAF CONTRACT F33615-90-D-4010, DELIVERY ORDER 14

September 1992

Prepared by:

**Engineering-Science, Inc.
1700 Broadway, Suite 900
Denver, Colorado**

SECTION 2

BIOVENTING SYSTEM OPERATION

2.1 PRINCIPLE OF OPERATION

Bioventing is the forced injection of fresh air, or withdrawal of soil gas, to enhance the supply of oxygen for in situ bioremediation. Either a pressure (air injection) or vacuum (vapor extraction) blower unit is used to inject or withdraw air into or from the soil, thereby supplying fresh air with 20.8 percent oxygen to the contaminated soils. Once oxygen is provided to the subsurface, existing bacteria will proceed with the breakdown of fuel residuals.

At _____ Air Force Base (AFB) a _____ blower system has been installed.

2.2 SYSTEM DESCRIPTION

2.2.1 Blower System

A _____ blower powered by a ___ horse power direct-drive motor is the workhorse of the bioventing system. This blower is rated at ___ scfm at ___ inches of water vacuum; however, the actual performance of the blower will vary with changing site conditions. As installed, the blower was producing an estimated flow rate of ___ scfm at ___ inches of water. Vapor extraction systems may include an inlet knockout chamber for water condensation. All systems include an air filter to remove any particulates which are entrained in the air stream and several valves and monitoring gauges which are described in the next section. A schematic of the blower system installed at _____ AFB, corresponding blower performance curves, and relevant service information are provided in Appendix A.

2.2.2 Monitoring Gauges

The bioventing system is equipped with vacuum and pressure gauges, temperature gauges, and a sampling port (vapor extraction only). Generally, gauges have been installed on the air injection system at the following locations; a vacuum gauge in the inlet piping and a pressure gauge in the outlet piping. For vapor extraction systems gauges are generally installed as follows; vacuum gauges in the inlet piping and at the knock-out pot (as applicable), and a pressure gauge in the discharge piping. See Figure 1 for the locations of the gauges installed on the blower system at this site.

SECTION 1

INTRODUCTION

This document has been prepared by Engineering-Science, Inc. to support the bioventing initiative contract awarded by the Air Force Center for Environmental Excellence. The contract involves the conducting of bioventing pilot tests at 35 sites on 23 Air Force bases across the United States.

At most sites, bioventing systems will be installed upon completion of the bioventing pilot tests for the purpose of extended pilot testing. These systems will operate for a one year period to provide further information as to the feasibility of the technology at each site, and to provide interim remedial action.

This Operations and Maintenance Manual has been created for sites at which regenerative type blowers have been installed for extended pilot testing. Basic maintenance of these systems is the responsibility of the base. The manual is to be used by base personnel to guide and assist them in operating and maintaining the blower system. Section 2 of this document describes the blower. Section 3 details the maintenance requirements and provides maintenance schedules. Section 4 describes the system monitoring that is required to forecast system maintenance needs and provide data for the extended pilot test.

Temperature gauges may be located at the inlet and outlet of the blower system. These gauges are used to monitor the inlet and outlet temperature to determine the change in temperature across the blower. For air injection systems ambient air temperature should be used when an inlet temperature gauge is not present. For vapor extraction systems the inlet temperature is also used as an estimate of soil gas temperatures in the contaminated soil zone. See Figure 1 for the location(s) of the temperature gauges installed on the blower system at this site.

A sample port is located in the discharge piping on the outlet side of vapor extraction systems only. This sample port is used to collect offgas that is analyzed for CO₂/O₂ and volatile organics concentrations. See Figure 1 for the location of the sampling port installed on the blower system at this site.

Product Specifications

| Model Number | Motor Specs | Full Load Amps | HP | RPM | Max Pressure | | Max Flow | | Net Wt. | |
|--------------|----------------------|-----------------|-----|------|-------------------|------|----------|--------------------|---------|------|
| | | | | | "H ₂ O | mbar | cfm | m ³ /hr | lbs. | kg |
| R4110-2 | 110/220-240-50-1 | 9.0/4.5-5.7 | 0.6 | 2850 | 38 | 95 | 74 | 126 | 41 | 18.6 |
| | 115/208-230-60-1 | 9.8/5.2-4.9 | 1.0 | 3450 | 52 | 130 | 92 | 156 | | |
| R4310A-2 | 190-220/380-415-50-3 | 2.6-3.3/1.3-1.4 | 0.6 | 2850 | 38 | 95 | 74 | 126 | 41 | 18.6 |
| | 208-230/460-60-3 | 3.4-3.2/1.8 | 1.0 | 3450 | 52 | 130 | 92 | 156 | | |

Product Performance (Metric U.S. Imperial)

Black line on curve is for 60 cycle performance.
Blue line on curve is for 50 cycle performance.

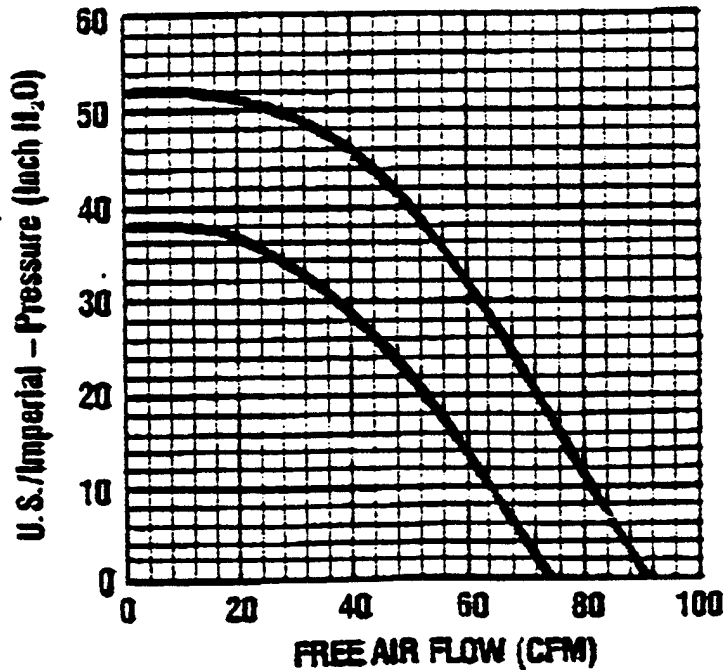
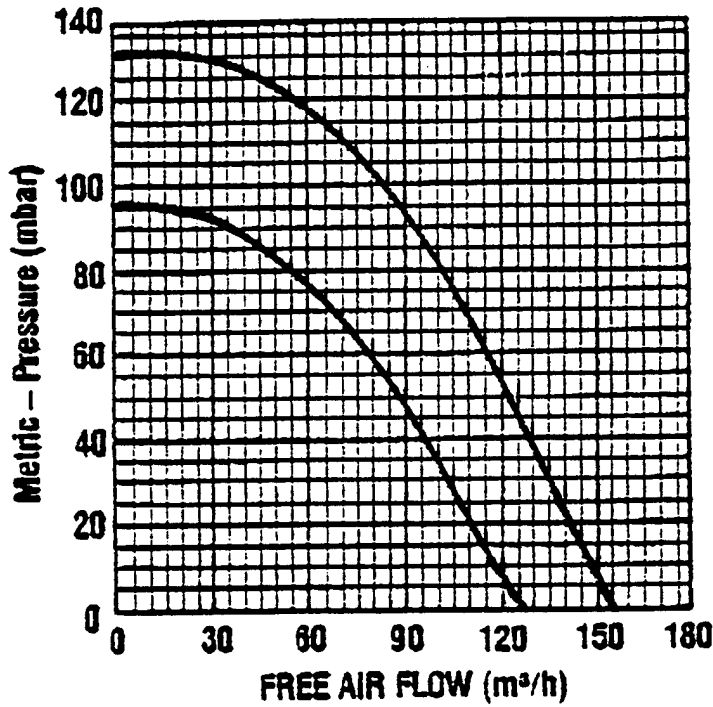

Product Specifications

| Model Number | Motor Specs | Full Load Amps | HP | RPM | Max Pressure | | Max Flow | | Net Wt. | |
|--------------|----------------------|-----------------|------|------|-------------------|------|----------|-------------------|---------|------|
| | | | | | "H ₂ O | mbar | cfm | m ³ /h | lbs. | kg |
| R5325A-2 | 190-220/380-415-50-3 | 6.6-6.7/3.3-3.5 | 1.35 | 2850 | 50 | 125 | 133 | 226 | 65 | 29.5 |
| | 208-230/460-3 | 6.9/3.45 | 2.5 | 3450 | 65 | 162 | 160 | 272 | | |
| R5125-2 | 115/208-230-50-1 | 22.4/12.4-11.2 | 2.5 | 3450 | 60 | 149 | 160 | 272 | 73 | 33.1 |

Product Performance (Metric U.S. Imperial)

Black line on curve is for 60 cycle performance.
Blue line on curve is for 50 cycle performance.

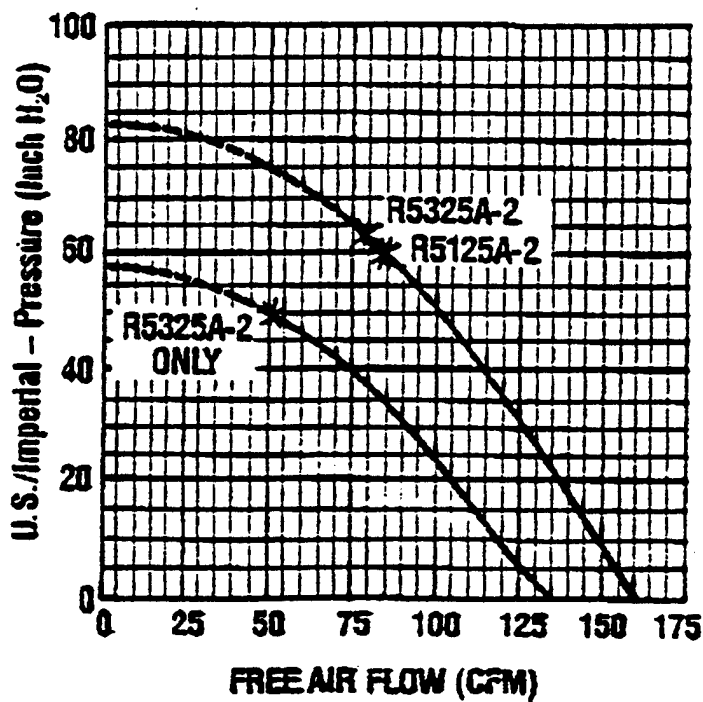
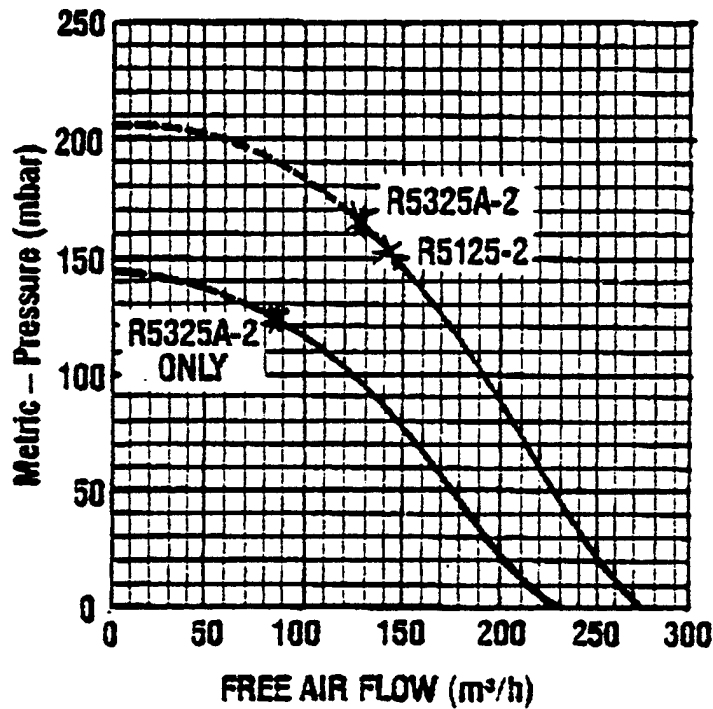

Recommended maximum duty.
--- Intermittent duty only.

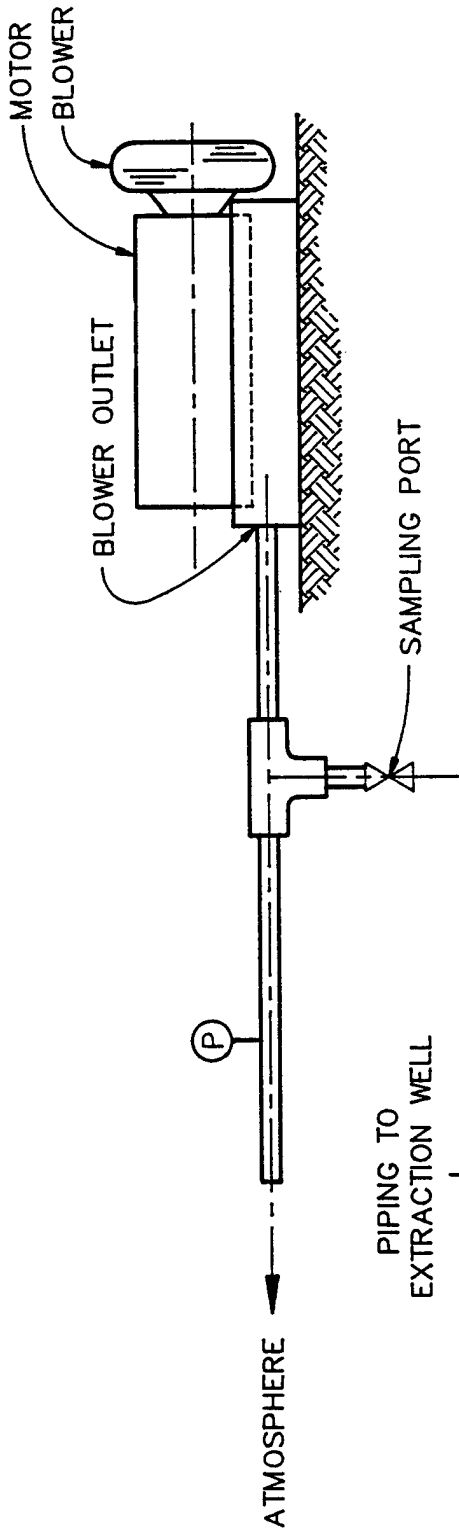

OUTLET SIDE
N.T.S.

LEGEND

- (T) TEMPERATURE GAUGE (1/4" NPT)
- (P) PRESSURE GAUGE (1/4" NPT)
- (V) VACUUM GAUGE (1/4" NPT)

PLAN VIEW - INLET SIDE
N.T.S.

**REGENERATIVE BLOWER
SYSTEM FOR AIR
EXTRACTION**

ENGINEERING-SCIENCE, INC.
Denver, Colorado

ES

26812-05, 09/14/92 at 10:10

N.T.S.

26812-01, 09/14/92 at 10:18

ENGINEERING-SCIENCE, INC.
Denver, Colorado

ES

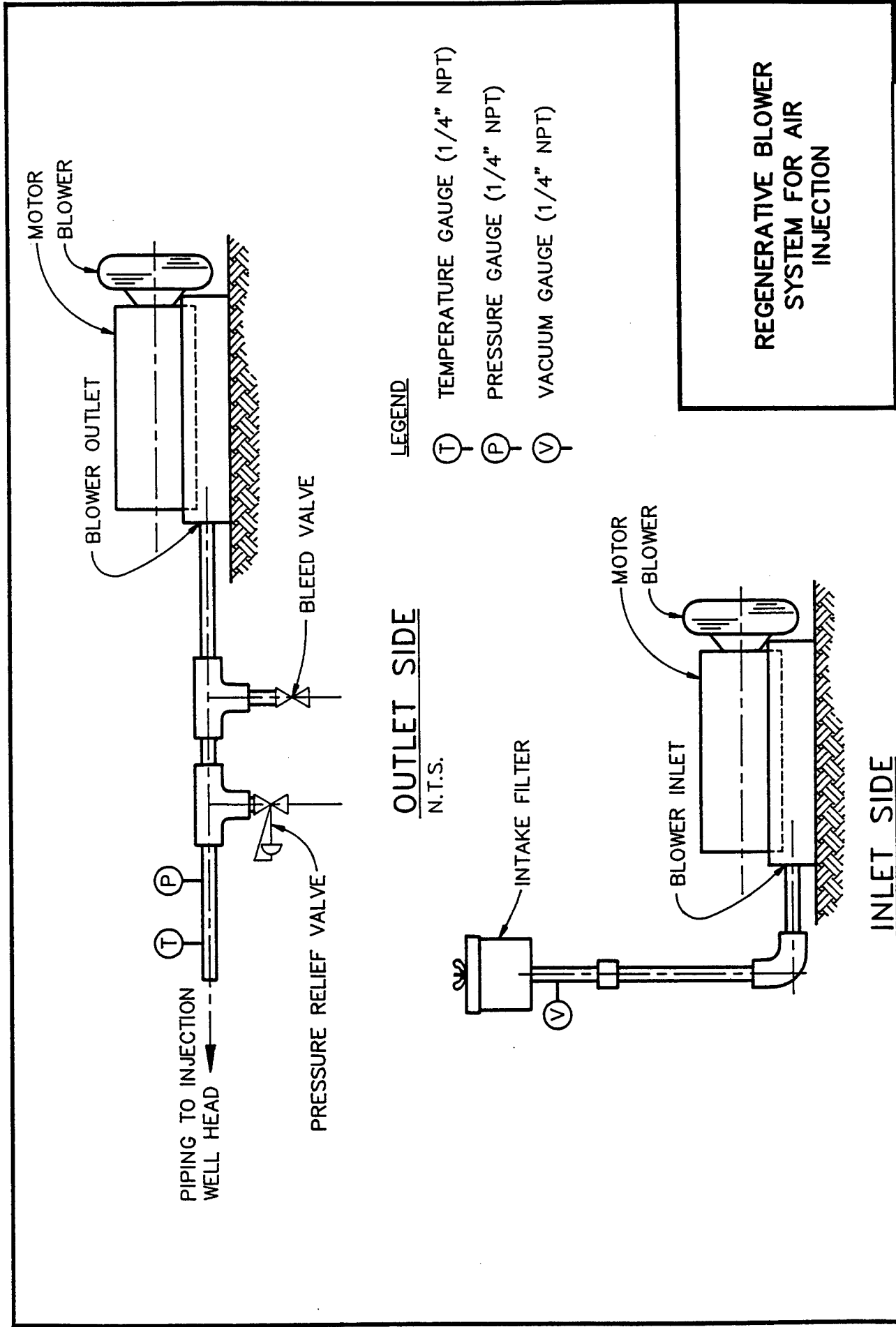

ENGINEERING-SCIENCE, INC.
 Denver, Colorado

26812-01, 09/14/92 at 10:18

APPENDIX B

APPENDIX C
CHAIN OF CUSTODY FORMS

ENGINEERING-SCIENCE

CHAIN OF CUSTODY RECORD

| ES JOB NO. | | PROJECT NAME/LOCATION | | PRESERVATIVES REQUIRED | | | | | | | | | | SHIP TO: |
|-----------------------------|------|-------------------------|------------|------------------------|-------------|---------|--------|---------|--------|--------------|---------------|-------------------|------------------|--------------------|
| | | W.D. 4484 | | | | | | | | | | | | Sequoia Analytical |
| FIELD CONTACT: | | ANALYSES REQUIRED | | | | | | | | | | | | |
| Rody Charbonnet | | | | | | | | | | | | | | |
| SAMPLERS NAMES & SIGNATURES | | | | | | | | | | | | | | |
| DATE | TIME | FIELD SAMPLE IDENTIFIER | TKN(351.2) | PHAS(365.3) | UCM (Class) | 4484-1B | 203618 | 4484-2B | 203619 | 1.) Use MDLs | 2.) Dry basis | 3.) Report MS/MSD | RESULTS (BS-BSD) | |
| 10/19/92 | 1430 | BE3-1W-10 | X | X | X | | | | | | | | Sub-Out | |
| | ↓ | BE3-1MP2-9 | X | X | X | | | | | | | | | |
| | | | | | | | | | | | | | NORMAL TMT | |
| | | | | | | | | | | | | | | |

FIELD CUSTODY RELINQUISHED BY: *[Signature]* DATE: 10/23/92 TIME: 1310

SHIPPED VIA: AIRBILL # ON RECEIPT: CUSTODY SEALS? ; TEMP: °C

RECEIVED FOR LABORATORY BY: *[Signature]* DATE: 10/23/92 TIME: 1510

RECOVERED BY: *[Signature]* 10/23/92 1515 rec'd by - K. Gravel 10-23-92 1515

ENGINEERING-SCIENCE
CHAIN OF CUSTODY RECORD FOR WATER SAMPLES

| ES JOB NO. | | PROJECT NAME/LOCATION | | PRESERVATIVES REQUIRED | | | | | | | | | | REMARKS | |
|-----------------------------|--|-------------------------|--|------------------------|---------------|-------------|--|--|--|--|--|--|--|---------|---------------------------|
| 4488 | | TO: SEQUOIA LAB. | | | | | | | | | | | | | |
| FIELD CONTAINER | | FIELD SAMPLE IDENTIFIER | | ANALYSES REQUIRED | | | | | | | | | | | |
| 10/23/92 | | 0628 | | | | | | | | | | | | | |
| SAMPLERS NAMES & SIGNATURES | | FIELD SAMPLE IDENTIFIER | | E351.2 (TKN) | E365.3 (PHDS) | VCM (CLASS) | | | | | | | | | |
| [Signature] | | 0E3-VMP-1-9 (4488.01B) | | ✓ | ✓ | ✓ | | | | | | | | | Report result on way |
| | | | | | | | | | | | | | | | Soil Basis. Use MDL'S for |
| | | | | | | | | | | | | | | | REPORTING LIMITS. |
| | | | | | | | | | | | | | | | REPORT METHODS BLANKS |
| | | | | | | | | | | | | | | | MS/MSD (10 DAY REPORT |
| | | | | | | | | | | | | | | | 7AT), REPORT MS/MSD, |
| | | | | | | | | | | | | | | | TO: TOM PAULSON OSBC |

Ed Delaney

DATE: 10/27/92 TIME: 1155
ON RECEIPT: CUSTODY SEALS? ; TEMP: °C

SHIPPED VIA: AIRBILL #
RECEIVED FOR LABORATORY BY: [Signature] DATE: 10/27/92 TIME: 1455

ENGINEERING FIELD CHAIN OF CUSTODY RECORD FOR WATER SAMPLES

TO: SEQUIA L

PROJECT NAME/LOCATION
4505

ES JOB NO.

FIELD CONTACT: *[Signature]*

AMPLERS NAMES & SIGNATURES

PRESERVATIVES REQUIRED

ANALYSES REQUIRED

DATE TIME FIELD SAMPLE IDENTIFIER

12/92 0744 (4505.01B)
BE18 - VW1-11

13/92 1440 (4505.2B)
BE18 - VMPI

✓ E351.2 (TKN)
✓ E365.3 (PHOS)
✓ KCM (CLASS)

21105 73
↓ 74

REMARKS

REPORT RESULT ON 1
2016 BASIS. USE 1
FOR REQUIREMENT
REPORT METHOD
MS/MSD. 10 CRY
REPORT TO: TOM
E3BL

Please watch
hold-times.

DATE: 11-5-92 TIME: 1055

FIELD CUSTODY RELINQUISHED BY: *[Signature]*

SHIPPED VIA: AIRBILL # ON RECEIPT: CUSTODY SEALS? ; TEMP:

DATE: 4/5/92 TIME: 1055

RECEIVED FOR LABORATORY BY: *[Signature]*

RECEIVED BY: *[Signature]* 11/5/92 K. G. ... 1039pm

