

LOAN DOCUMENT

PHOTOGRAPH THIS SHEET

①

INVENTORY

DTIC ACCESSION NUMBER

LEVEL

Close Sampling & Analysis Plan for...
DOCUMENT IDENTIFICATION
Sep 95

DISTRIBUTION STATEMENT A
Approved for Public Release
Distribution Unlimited

DISTRIBUTION STATEMENT

ACCESSION FOR	
NTIS	GRAB <input type="checkbox"/>
DTIC	TRAC <input type="checkbox"/>
UNANNOUNCED	<input type="checkbox"/>
JUSTIFICATION	<input type="checkbox"/>
BY	
DISTRIBUTION/	
AVAILABILITY CODES	
DISTRIBUTION	AVAILABILITY AND/OR SPECIAL
A-1	

DISTRIBUTION STAMP

DATE ACCESSIONED

DATE RETURNED

20001122 051

DATE RECEIVED IN DTIC

REGISTERED OR CERTIFIED NUMBER

H
A
N
D
L
E

W
I
T
H

C
A
R
E

PHOTOGRAPH THIS SHEET AND RETURN TO DTIC-FDAC

DRAFT

Closure Sampling and Analysis Plan

for

**IRP Site 43 Building 1200 Former Diesel UST Site
Edwards AFB, California**

Prepared For

**Air Force Center for Environmental Excellence
Brooks AFB, Texas**

and

Edwards AFB, California

Parsons Engineering Science, Inc.

SEPTEMBER 1995

9404 Genesee Avenue, Suite 140
La Jolla, California 92037

ES ENGINEERING-SCIENCE

DEFENSE TECHNICAL INFORMATION CENTER REQUEST FOR SCIENTIFIC AND TECHNICAL REPORTS

Title AFCEE Collection

1. Report Availability (Please check one box)

- This report is available. Complete sections 2a - 2f.
- This report is not available. Complete section 3.

**2a. Number of
Copies Forwarded**

each

2b. Forwarding Date

July/2000

2c. Distribution Statement (Please check ONE box)

DoD Directive 5230.24, "Distribution Statements on Technical Documents," 18 Mar 87, contains seven distribution statements, as described briefly below. Technical documents MUST be assigned a distribution statement.

- DISTRIBUTION STATEMENT A: Approved for public release. Distribution is unlimited.
- DISTRIBUTION STATEMENT B: Distribution authorized to U.S. Government Agencies only.
- DISTRIBUTION STATEMENT C: Distribution authorized to U.S. Government Agencies and their contractors.
- DISTRIBUTION STATEMENT D: Distribution authorized to U.S. Department of Defense (DoD) and U.S. DoD contractors only.
- DISTRIBUTION STATEMENT E: Distribution authorized to U.S. Department of Defense (DoD) components only.
- DISTRIBUTION STATEMENT F: Further dissemination only as directed by the controlling DoD office indicated below or by higher authority.
- DISTRIBUTION STATEMENT X: Distribution authorized to U.S. Government agencies and private individuals or enterprises eligible to obtain export-controlled technical data in accordance with DoD Directive 5230.25, Withholding of Unclassified Technical Data from Public Disclosure, 6 Nov 84.

2d. Reason For the Above Distribution Statement (in accordance with DoD Directive 5230.24)

2e. Controlling Office

HQ AFCEE

**2f. Date of Distribution Statement
Determination**

15 Nov 2000

3. This report is NOT forwarded for the following reasons. (Please check appropriate box)

- It was previously forwarded to DTIC on (date) and the AD number is
- It will be published at a later date. Enter approximate date if known.
- In accordance with the provisions of DoD Directive 3200.12, the requested document is not supplied because:

Print or Type Name

Laura Peña

Signature

Laura Peña

Telephone

210-536-1431

(For DTIC Use Only)

AQ Number

MOI-01-0330

DRAFT

**Closure Sampling and Analysis Plan
for
IRP Site 43 Building 1200 Former Diesel UST Site
Edwards AFB, California**

Prepared for:

**Air Force Center for Environmental Excellence
Brooks AFB, Texas
and
Edwards AFB, California**

September 1995

**Parsons Engineering Science, Inc.
9404 Genesee Avenue, Suite 140
La Jolla, California 92037**

CONTENTS

	Page
1 INTRODUCTION.....	1-1
2 SITE DESCRIPTION AND HISTORY	2-1
2.1 Site Description.....	2-1
2.2 Site Geology	2-1
2.3 Previous Investigations.....	2-1
2.3.1 UST Removal	2-1
2.3.2 Soil Investigation 1992.....	2-3
2.3.3 Bioventing: 1993-1994.....	2-3
3 SITE CLOSURE REQUIREMENTS	3-1
3.1 Site Soil Cleanup Standards.....	3-1
4 SITE CLOSURE SAMPLING AND ANALYSIS PLAN	4-1
4.1 Site Closure Borehole Locations and Sampling Depths.....	4-1
4.2 Drilling, Sampling, and Equipment Decontamination.....	4-1
4.3 Soil Sample Analysis	4-4
5 SITE CLOSURE REPORT FORMAT	5-1
6 REFERENCES	6-1

FIGURES

<u>Figure</u>	<u>Description</u>	<u>Page</u>
2.1	IRP Site 43 Building 1200 Former Diesel UST Site Layout	2-2
2.2	IRP Site 43 Building 1200 Bioventing System Location	2-5
2.3	IRP Site 43 Building 1200 Geologic Cross Section A-A'	2-6
4.1	IRP Site 43 Building 1200 Proposed Site Closure Borehole Locations	4-2

TABLES

<u>Table</u>	<u>Description</u>	<u>Page</u>
2.1	Tank Bed Bottom Soil Analytical Results IRP Site 43, Building 1200 Former Diesel UST Site Edwards AFB, California	2-3
2.2	Soil Analytical Results, November 1992 IRP Site 43, Building 1200 Former Diesel UST Site Edwards AFB, California	2-4
2.3	Initial and 1-Year Soil and Soil Gas Analytical Results IRP Site 43 Building 1200 Former Diesel UST Site	2-7
3.1	California Regional Water Quality Control Board Soil Cleanup Standards	3-2
4.1	Proposed Soil Sample Analytical Methods and Practical Quantitation Limits	4-4

SECTION 1

INTRODUCTION

During the past two years, Edwards Air Force Base (AFB) has participated in the Air Force Bioventing Pilot Test Initiative Project. Sponsored by the Air Force Center for Environmental Excellence (AFCEE) at Brooks AFB, Texas, the project included conducting more than 135 *in situ* bioventing pilot tests at 48 Air Force installations throughout the country. These tests were designed to collect data on the effectiveness of bioventing for the remediation of soil contaminated with fuel hydrocarbons (i.e., JP-4 jet fuel, diesel fuel, gasoline, heating oil, etc.). One-year-long bioventing pilot tests have recently been concluded at three Edwards AFB sites. Based on the results of these one-year tests, *in situ* bioventing has been effective enough to support closure of the IRP Site 43 Building 1200 Former Diesel underground storage tank (UST) Site.

This Site Closure Sampling and Analysis Plan (SAP) has been prepared by Parsons Engineering Science, Inc. (Parsons ES) for submittal to the Kern County Department of Environmental Health (Kern County). This SAP presents a plan for confirmation soil sampling and analysis to document the effectiveness of soil remediation at this site and to demonstrate compliance with regulatory requirements for closure. It is anticipated that analytical results will support a no-further-action recommendation, and that Kern County will grant site closure.

This SAP consists of six sections, including this introduction. Section 2 includes site descriptions, histories, and summaries of previous investigations and remediation activities. Section 3 summarizes all applicable site closure requirements. A detailed site closure SAP is presented in Section 4. Analytical results will be presented in a site closure report as described in Section 5. Section 6 provides references cited in this SAP.

SECTION 2

SITE DESCRIPTION AND HISTORY

2.1 SITE DESCRIPTION

Building 1200 is located between Wolfe Avenue to the northwest and the main taxi way to the southeast (Figure 2.1). Building 1200 houses the flightline manager operations facility. The former underground storage tank (UST) area is located to the west of Building 1200, within IRP Site 43. The former 165-gallon diesel UST was used to store fuel for an emergency generator located adjacent to Building 1200. The former diesel tank location, with respect to Building 1200, is shown on Figure 2.1.

Site information provided by Edwards AFB was limited to results of soil samples collected during tank removal. The information did not include: (1) tank removal date; (2) the nature of backfill and native material; (3) the extent of contamination left in place; and (4) the soil boring logs and analytical results from site investigation borings for a nearby groundwater monitoring well.

2.2 SITE GEOLOGY

Soils encountered during bioventing system installation (Parsons ES, 1994) included sand from ground surface to 5 to 7 feet bgs followed by silty sand from the bottom of the sand to 15 feet bgs. Weathered granite bedrock was not encountered but is anticipated at approximately 20 to 35 feet bgs at Site 43. In January 1995, the depth to groundwater was measured at 31.5 feet bgs in well 43-MW-47. The well is located approximately 55 feet southeast of the site.

2.3 PREVIOUS INVESTIGATIONS

2.3.1 UST Removal

As previously mentioned, the exact tank removal date is unknown. However, during tank removal activities, two soil samples were collected at approximately two and six feet below the former tank bed bottom. The hydrocarbon concentrations detected are shown in Table 2.1 (Earth Tech, 1991).

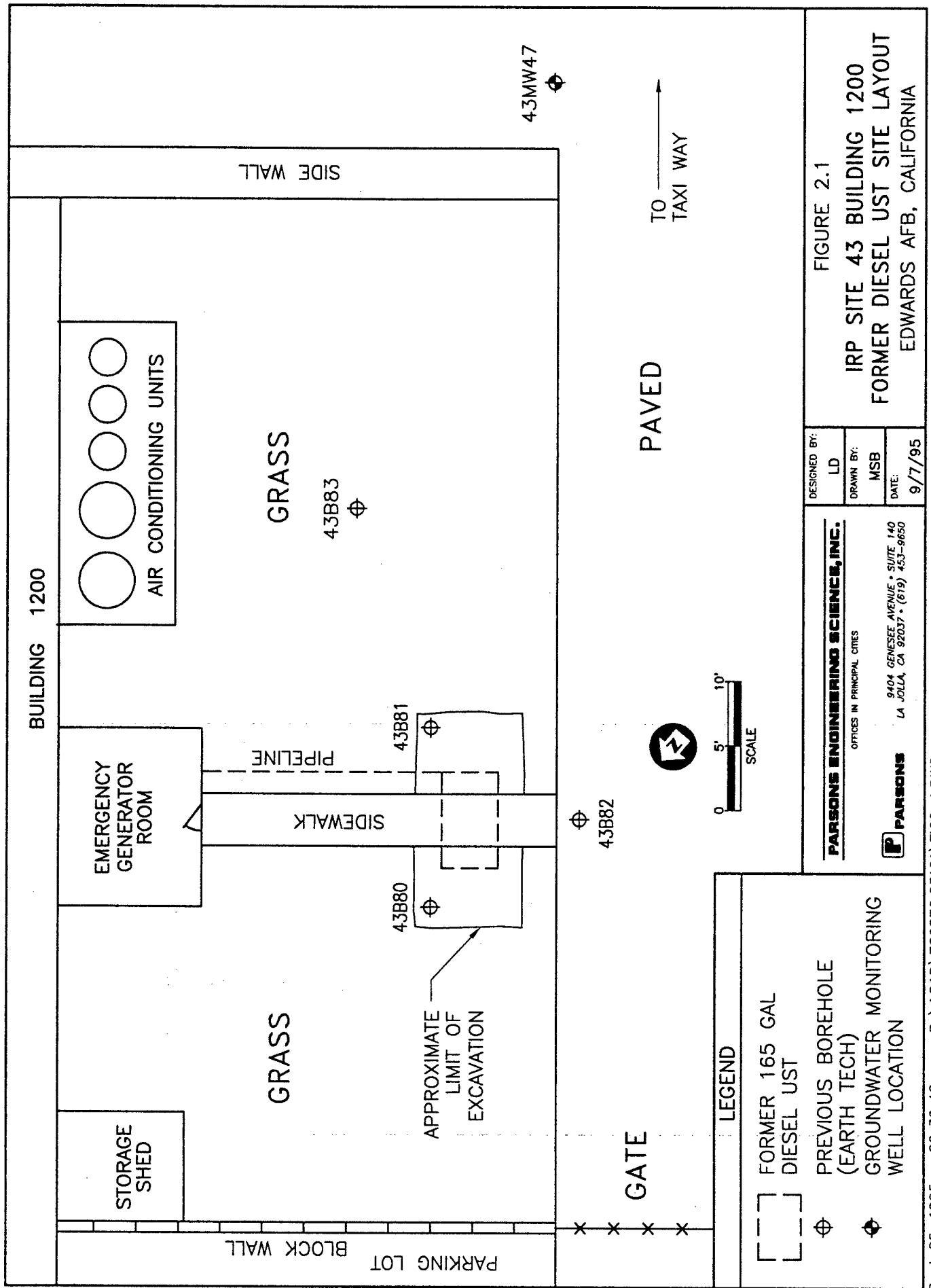

Table 2.1

**Tank Bed Bottom Soil Analytical Results
IRP Site 43, Building 1200 Former Diesel UST Site
Edwards AFB, California**

Sample No.	Depth (feet bgs)	EPA 8015 Mod. Diesel (mg/kg)	EPA 602 in (mg/kg)			
			Benzene	Toluene	Ethyl Benzene	Xylenes
S1	6.0	22,620	ND	1.19	3.333	20.6
S2	10.8	277.8	ND	ND	ND	ND

2.3.2 Soil Investigation 1992

In November 1992, several soil boreholes were drilled and sampled by Earth Tech, and a groundwater monitoring well was installed in one borehole. The borehole and well locations are shown on Figure 2.1. Three samples were collected from each borehole. Samples were analyzed by EPA Method 8015 Modified for diesel and JP4, Method 8240 for volatile organic compounds and Method SW 8270 for semi-volatile organic compounds. All results were non-detect at the method reporting limit as summarized in Table 2.2 (Earth Tech, 1992).

2.3.3 Bioventing: 1993-1994

Bioventing pilot testing activities were conducted by Parsons ES beginning in September 1993. As part of the pilot test, one vent well (VW) for injection of air into the subsurface and one soil gas monitoring point (MP) were installed at the site. Two other borings, SB1 and SB2, were drilled at the site. Because these borings had no field evidence of contamination, they were backfilled with bentonite. No samples were collected from these two borings. VW and MP locations are shown on Figure 2.2 and in cross section on Figure 2.3. Because the project focus was on bioventing rather than site characterization, only limited sampling was performed. Three soil and two soil gas samples were collected from the VW and MP. Analytical results are presented in Table 2.1. Detailed pilot testing procedures and results are presented in the bioventing report (Parsons ES, 1994).

Initial testing indicated the extent of contamination is limited to approximately 3 to 5 feet from the VW and extends to at least 15 feet bgs. MPA, located 7 feet from the VW, had no field or laboratory evidence of contamination. Because MPA had no

Table 2.2

Soil Analytical Results, November 1992
 IRP Site 43, Building 1200 Former Diesel UST Site
 Edwards AFB, California

Borehole I.D.	Sample Depth (feet bgs)	EPA 8015 Mod. Diesel (mg/kg)	EPA 8015 Mod. JP4 (mg/kg)	SW 8240 (mg/kg)	SW 8270 (mg/kg)
43B80	10	ND	ND	ND	--
43B80	15	ND	ND	ND	ND
43B80	30	ND	ND	ND	ND
43B81	0	ND	ND	ND	--
43B81	10	ND	ND	ND	ND
43B81	15	ND	ND	ND	ND
43B82	5	ND	ND	ND	ND
43B82	20	ND	ND	ND	--
43B82	30	ND	ND	ND	ND
43B83	5	ND	ND	ND	ND
43B83	15	ND	ND	ND	ND
43B83	25	ND	ND	ND	--

ND = Non-detect at method reporting limit.

-- = Not analyzed.

evidence of contamination, a respiration test was conducted in the VW. The test indicated a hydrocarbon reduction rate of approximately 150 mg of hydrocarbons per kg of soil per year. This low rate was most likely the result of vent well dilution (i.e., oxygen from non-contaminated zones entering the vent well thereby masking the oxygen utilization rate of the contaminated zone).

Long-term air injection at the IRP Site 43 former diesel UST site began in September 1993. Year-end sampling completed in November 1994 indicated a 99.5 to 99.8 percent reduction in TVH in the soil gas sample and TRPH reductions of 84.6 percent and 96.1 percent in two of the three soil samples (Table 2.3). The year-end respiration test indicated a hydrocarbon biodegradation rate of approximately 170 mg/kg per year. Following year-end testing, the blower was restarted and is currently injecting

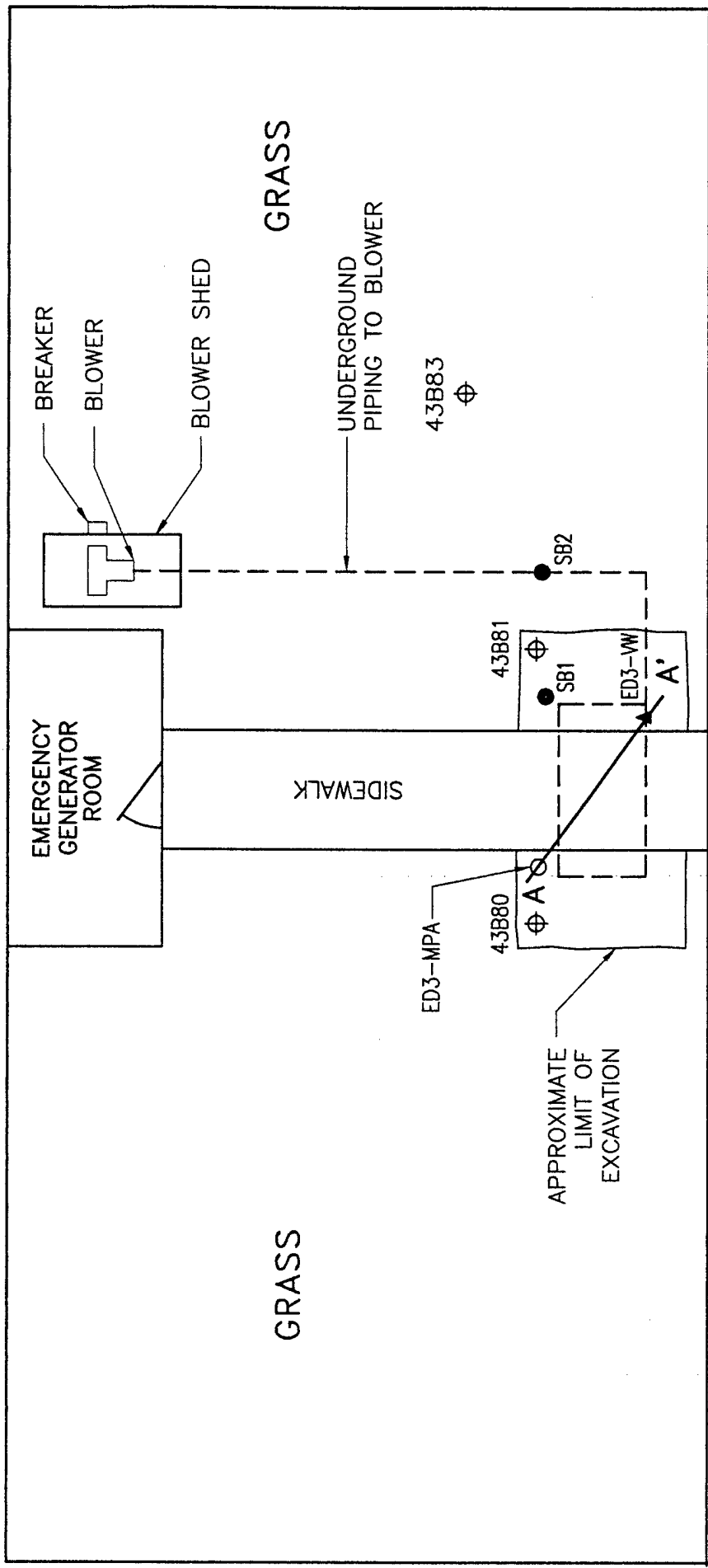

PAVED

LEGEND

- [] FORMER 165 GAL DIESEL UST
- ⊕ PREVIOUS BOREHOLE (EARTH TECH)
- ▲ VENT WELL
- MONITORING POINT
- BOREHOLE
- A—A' GEOLOGICAL CROSS SECTION LOCATION

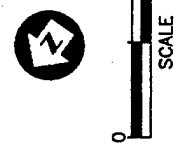

PARSONS ENGINEERING SCIENCE, INC.
OFFICES IN PRINCIPAL CITIES

DESIGNED BY: LD
DRAWN BY: MSB
DATE: 9/7/95

9404 GENESEE AVENUE - SUITE 140
LA JOLLA, CA 92037 • (619) 451-9650

PARSONS

FIGURE 2.2
IRP SITE 43 BUILDING 1200
BIOVENTING SYSTEM LOCATION
EDWARDS AFB, CALIFORNIA

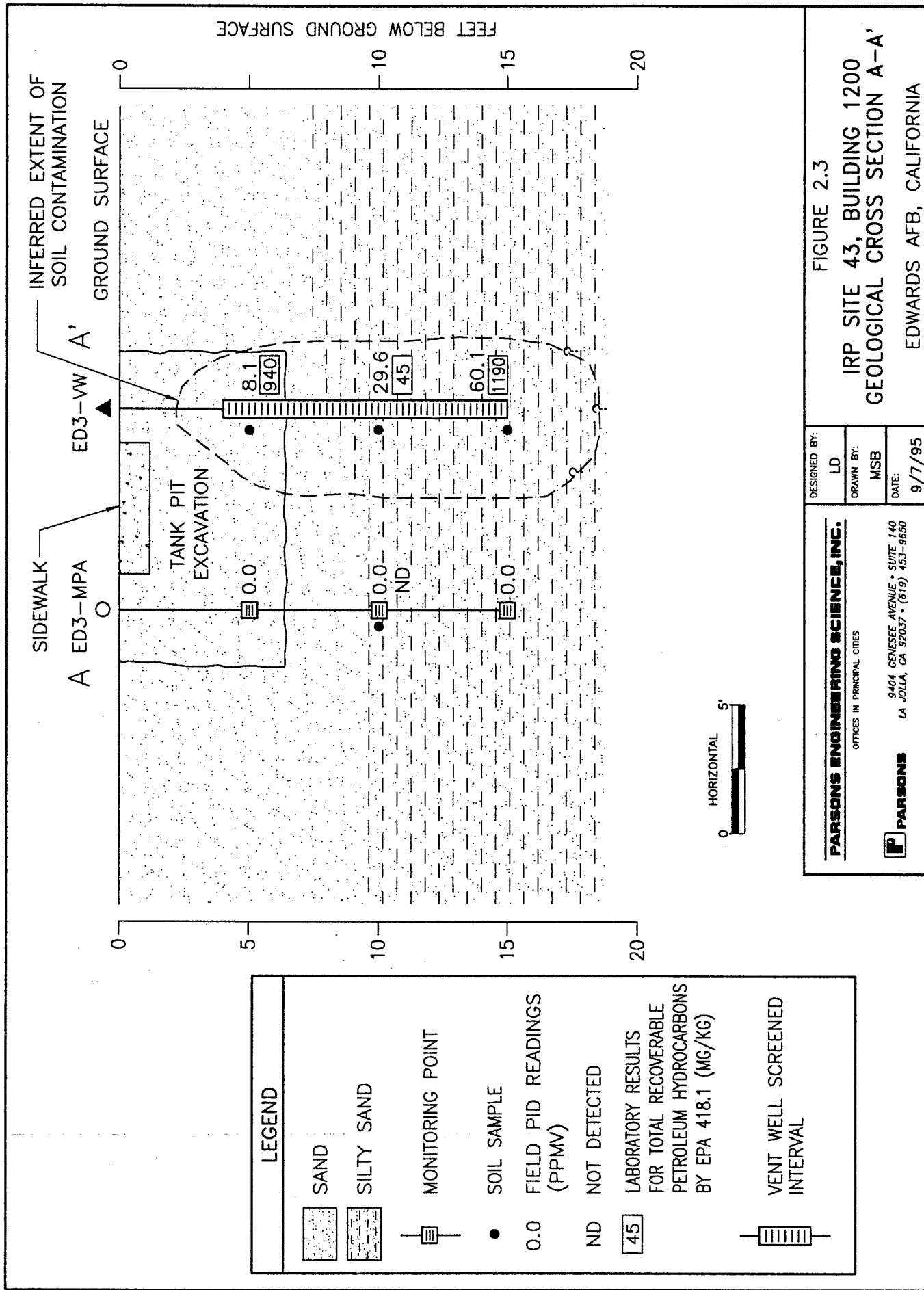

Table 2.3

Initial and 1-Year Soil and Soil Gas Analytical Results
 IRP Site 43 Building 1200 Former Diesel UST Site
 Edwards AFB, California

Analyte (units) ^{a/}	Sample Location-Depth (feet below ground surface)					
	VW		MPA-15		MPA-10	
Soil Gas Hydrocarbons	Initial ^{b/}	1-Year ^{d/}	Initial	1-Year	Initial	1-Year
TVH (ppmv)	690	1.5	76	0.40		
Benzene (ppmv)	<0.023	<0.002	<0.002	<0.002		
Toluene (ppmv)	<0.023	0.011	0.006	<0.002		
Ethylbenzene (ppmv)	0.18	0.022	<0.002	<0.002		
Xylenes (ppmv)	0.95	0.21	<0.002	<0.002		
Soil Hydrocarbons	VW-5		VW-10		VW-15	
	Initial ^{d/}	1-Year ^{e/}	Initial	1-Year	Initial	1-Year
TRPH (mg/kg)	940	37.3	45	71.1	1190	184
Benzene (mg/kg)	<0.29	<0.05	<0.0006	<0.05	<0.27	<0.05
Toluene (mg/kg)	<0.29	<0.05	<0.0006	<0.05	<0.27	<0.05
Ethylbenzene (mg/kg)	0.37	<0.05	<0.0006	<0.05	<0.27	<0.05
Xylenes (mg/kg)	1.6	<0.1	<0.0008	<0.1	1.1	<0.1
Moisture (%)	13	1.2	8.2	1.0	9	3.0
					7.4	1.4

^{a/} TVH = total volatile hydrocarbons; ppmv = parts per million, volume per volume;

TRPH = total recoverable petroleum hydrocarbons; mg/kg = milligrams per kilogram.

^{b/} Initial soil gas samples collected on 9/10/93 and 9/11/93.

^{c/} 1-Year soil gas samples collected on 11/1/94.

^{d/} Initial soil samples collected on 9/8/93.

^{e/} 1-Year soil samples collected on 11/4/94.

air into the VW. Based on the encouraging year-end sampling and testing results, it is anticipated that site TRPH concentrations are below 100 mg/kg, and the BTEX concentrations are below detection limits. It is also anticipated that results of sampling described in Section 4 will support site closure.

SECTION 3

SITE CLOSURE REQUIREMENTS

Site specific closure requirements were described by Mr. Westly Nicks, the Kern County Project Engineer, to Mr. Larry Dudus (Parsons ES) in a 22 August 1995 telephone conversation. Mr. Nicks has requested two additional soil boreholes be drilled and sampled at the site adjacent to the vent well. Both borings are to be located in the former tank bed, with one adjacent to the vent well. Samples are to be collected at 5-foot intervals until two consecutive samples with no field detectable contamination are encountered. A detailed sampling and analysis plan is presented in Section 4.

3.1 SITE SOIL CLEANUP STANDARDS

In February 1995 the California Regional Water Quality Control Board (RWQCB), Los Angeles Region, released its Interim Site Assessment and Cleanup Guidebook. Site cleanup guidance is included in Volume I of the guidebook. The guidebook sets specific numerical cleanup goals based on type of contaminant, depth to groundwater and potential use of groundwater (i.e., drinking water).

Kern County generally follows the recommendations presented in the guidebook. Soil cleanup standards for petroleum-impacted sites are presented in Section 5 of the guidebook and in Table 3.1. Depth to groundwater at the site is approximately 32 feet below ground surface (bgs) and is considered to be drinking water by the California RWQCB. Therefore, Level A cleanup standards apply.

Table 3.1
California Regional Water Quality Control Board
Soil Cleanup Standards
(mg/kg or ppm)

	Distance Above Groundwater (ft)		
	<40	40-150	>150
ABOVE DRINKING WATER	LEVEL A	LEVEL B	LEVEL C
BTEX + FA	MCL	10 MCL	100 MCL
TPH (Carbon Range)			
C4 - C12	10	100	1000
C13 - C22	100	1000	10000
C23 +	1000	10000	10000
ABOVE NON-DRINKING WATER	LEVEL D (FOR ANY DEPTH TO GROUNDWATER)		
BTEX + FA	100 MCL		
TPH (Carbon Range)			
C4 - C12	1000		
C13 - C22	10000		
C23 +	15000		

Source: RWQCB, 1995.

MCLS: B = 0.001 (ppm), T = 0.1 (ppm), E = 0.68 (ppm), X = 1.75 (ppm), Pb = 0.015 (ppm),
EDB + 0.02 (ppb),
PAH = 0.2 (ppb)

- MCL = Maximum contaminant levels.
- BTEX = Benzene, toluene, ethylbenzene, and xylenes, respectively.
TPH = Total petroleum hydrocarbons.
FA = Fuel additives, lead (Pb), ethylene dibromide (EDB), etc., including other components (i.e., PAH) of petroleum products which have MCLS.
- Use of this table assumes the original source has been removed and an adequate site assessment has been completed.
- For BTEX or FA, each component is not to exceed 1, 10, or 100 times its MCL as specified.
- For TPH, the total allowable for each range is not to be exceeded and the overall total is not to exceed the given value for the heavier TPH (C23+).
- Soil levels below the appropriate levels in this table require no action, soil levels above the appropriate levels in this table must be remediated to or below provided levels, or a site-specific analysis must be conducted, or justification provided to determine more appropriate levels for an individual site. Groundwater monitoring may be required if soil contamination linkage to groundwater impact has been confirmed.
- BTEX to be analyzed by EPA Method 8020, or EPA Method 8260 (usually to confirm positive benzene).
- TPH to be analyzed by EPA Methods 418.1 and 8015 (Modified). Ranges of TPH to be analyzed by GC/MS carbon range methods or EPA Method 8015 (DHS Modified). PAH to be analyzed by EPA Method 8310.
- Use of Non-Drinking Water Levels are dictated by either water characteristics as defined and exempted under SWRCB Resolution 88-63 (TDS > 3000 mg/L, deliverability < 200 gal/day, or existing contamination that cannot be reasonably treated), or as agreed upon by Regional Board staff for use at a particular site.
- Minimum clean interval below impacted area to be determined on a site-specific basis by Regional Board staff, generally 40' above drinking waters and 20' above non-drinking waters.

SECTION 4

SITE CLOSURE SAMPLING AND ANALYSIS PLAN

The following SAP describes the borehole locations and sampling depths, soil sampling procedures, and analytical methods proposed to collect sufficient data to support site closure. This plan has been prepared and will be implemented by, or under the direct supervision of, a California Registered Geologist as required by the California RWQCB (1995) Interim Site Assessment and Clean-up Guidebook (see Section 3).

4.1 SITE CLOSURE BOREHOLE LOCATIONS AND SAMPLING DEPTHS

To confirm that site contamination has been remediated to within acceptable levels, Parsons ES proposes to drill and sample two additional boreholes. Proposed borehole locations are shown on Figure 4.1. Samples for chemical analysis will be collected at 5-foot intervals, beginning at 5 feet bgs. Sampling will continue at 5-foot intervals until two consecutive samples have no field evidence of contamination (i.e., soil with above-background photo ionization detector (PID) and total volatile hydrocarbon analyzer (TVHA) readings, petroleum odor, or discoloration).

In the unlikely event that analytical results indicate additional site remediation is required, the VW and MP will not be abandoned at this time. Should site closure be granted, Edwards AFB will make arrangements for the VW and MP to be properly abandoned (abandonment is not currently included in the Parsons ES' Scope of Work).

4.2 DRILLING, SAMPLING, AND EQUIPMENT DECONTAMINATION

Boreholes will be advanced using a drill rig equipped with 6-inch outside-diameter (OD) hollow-stem augers. Soil cuttings generated during drilling will be placed in US Department of Transportation (DOT)-approved, 55-gallon drums. The drums will be labeled with the site name, drilling date, borehole number, and depth intervals. Boreholes will be logged by a Parsons ES geologist. Soil types will be classified according to the Unified Soil Classification System (USCS) and described in accordance with the standard Parsons ES soil description format.

Before use and between boreholes, augers and other downhole equipment will be cleaned to prevent cross-contamination. Cleaning will be accomplished using a high-pressure hot-water wash, followed by a potable water rinse. Decontamination fluids will be collected and contained in labeled 55-gallon drums.

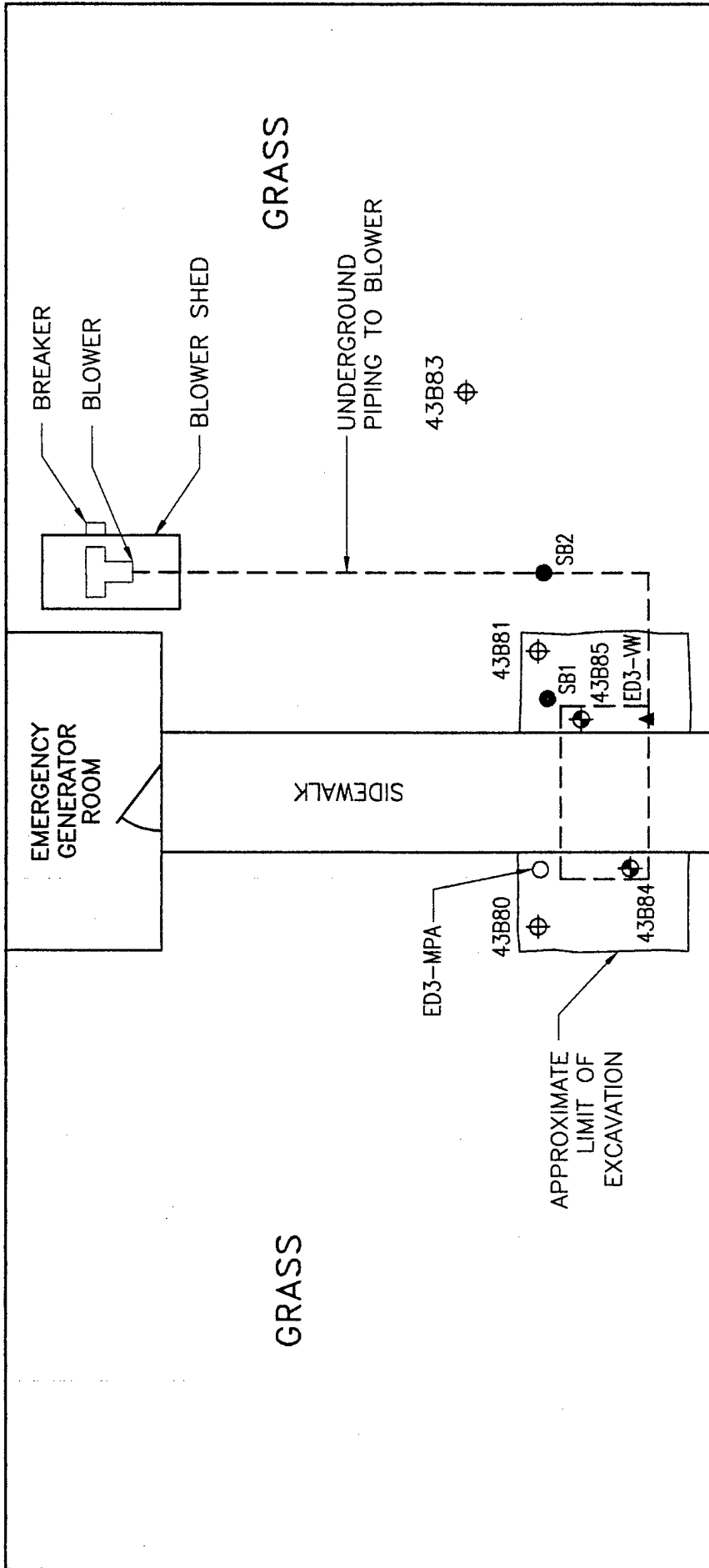

PAVED

LEGEND

[]	FORMER 165 GAL DIESEL UST
⊕	PREVIOUS BOREHOLE (EARTH TECH)
▲	VENT WELL
○	MONITORING POINT
●	BOREHOLE
⊕	SITE CLOSURE BOREHOLE

DESIGNED BY: LD
 DRAWN BY: MSB
 DATE: 9/7/95

PARSONS ENGINEERING SCIENCE, INC.
 OFFICES IN PRINCIPAL CITIES
 9404 GENESEE AVENUE • SUITE 140
 LA JOLLA, CA 92037 • (619) 453-9650

FIGURE 4.1
 IRP SITE 43 BUILDING 1200
 PROPOSED SITE CLOSURE
 BOREHOLE LOCATIONS
 EDWARDS AFB, CALIFORNIA

Relatively undisturbed soil samples, suitable for chemical analysis, will be collected at approximately 5-foot intervals unless specified otherwise. Soil samples will be collected in a 2.5-inch inside-diameter (ID) split-barrel sampler that will be lowered through the hollow stem of the augers and driven approximately 1.5 feet (or to refusal, if shallower) into undisturbed soil, ahead of the augers. Between sampling events, the split-barrel sampler will be cleaned with Alconox® detergent, followed by successive potable and distilled water rinses.

The split-sampler will be fitted with three precleaned, 2.5-inch OD by 6-inch-long, thin-walled, brass sleeves. Before samples are collected, sample sleeves will be cleaned using the same procedure as that for the sampler. After collection of a sample, the sampler will be retrieved, split apart, and the sleeves will be removed. The ends of the lowest sleeve that contains the sample for chemical analysis will be covered with Teflon® sheets and plastic end caps.

The upper sample sleeves will be used for logging purposes, and will be screened in the field for organic vapors using a PID and a TVHA. The data obtained from the logging and screening will be recorded on the borehole logs.

The sleeves for chemical analysis will be labeled with the site name and borehole number, sample depth, date of collection, project name, and other pertinent data. These sleeves will be placed immediately in an insulated shipping container with ice, and will be maintained in a chilled condition until delivered to the analytical laboratory. Chain-of-custody records will be prepared in the field and will accompany the samples to the analytical laboratory.

After sampling, boreholes will be backfilled with bentonite chips (hole plug) to approximately 1 foot bgs. The bentonite will be hydrated during placement at a rate of 2 to 5 gallons of water per 50-pound bag of chips. A concrete cap approximately 1-foot thick will be placed on top of the bentonite.

In the unlikely event that two consecutive "clean" samples are not collected before the groundwater table is encountered, a groundwater monitoring well will be installed. Well screen will consist of 2-inch internal diameter Schedule 40 PVC with 0.020-inch slots. The screen will extend approximately 10 feet into and five feet above the saturated zone. A No. 3 Lone Star (or equivalent) filter sand will be placed in the annulus to one foot above the screen. A bentonite pellet seal 3-feet thick will be placed above the filter pack. The remaining annulus to 1 foot bgs will be filled with bentonite chips. A water-tight well vault will be installed in a 2.5- x 2.5- x 8-inch deep concrete slab flush with the ground surface.

Additional information on well development purging sampling and analysis will be submitted to Kern County should well installation become necessary.

4.3 SOIL SAMPLE ANALYSIS

Proposed sample analytical methods and detection limits are presented in Table 4.1. All samples will be analyzed by a State of California-certified and AFCEE-approved laboratory.

Parsons ES proposes to analyze all soil samples by EPA Method SW8015 Modified for TPH as diesel and by EPA Method SW8020 for BTEX. Because the former UST contained diesel fuel (not gasoline) Parsons ES does not propose analyzing for lead or any other possible fuel additives. TPH results will be reported for each carbon chain (i.e., C4-C23+). This will allow for comparison with greater accuracy to California RWQCB (1995) clean-up standards listed in the *Interim Guidance For Remediation of Petroleum Impacted Sites* (see Subsection 3.2).

Table 4.1
Proposed Soil Sample Analytical Methods and
Practical Quantitation Limits

Analytical Method	PQL (mg/kg) ^{a/}
EPA SW8015 Modified for Diesel ^{b/} (California Department of Health Services Method)	5.0
EPA SW8020	
Benzene	0.001
Toluene	0.005
Ethylbenzene	0.005
Xylenes	0.05

^{a/} PQL = practical quantitation limit; mg/kg = milligrams per kilogram

^{b/} Results will be reported for each carbon chain using the simulated distillation method.

SECTION 5

SITE CLOSURE REPORT FORMAT

Following receipt of the laboratory analytical results, a site closure report will be prepared and submitted to Kern County, Edwards AFB, and AFCEE.

The report will contain the following information for each site:

- Plot plans showing final borehole locations;
- Summary of field activities;
- Assessment of analytical results in comparison to state cleanup criteria;
- Laboratory analytical reports and chain-of-custody forms;
- Borehole logs; and
- Conclusions and recommendations for site closure or additional cleanup action.

The report will be prepared and signed by a California Registered Geologist.

SECTION 6

REFERENCES

- California Regional Water Quality Control Board, Los Angeles Region, (RWQCB). 1995. *Interim Site Assessment and Clean-up Guidebook*. Vol I. February.
- Parsons Engineering Science, Inc. 1994. *Draft Bioventing Pilot Test Interim Results Report for IRP Site 43 Building 1200 Former Diesel UST*. Prepared for Air Force Center for Environmental Excellence. January.
- The Earth Technology Corporation. 1991. *Underground Tank Removal Soil Sampling Report Field Note Worksheet and Soil Sample Analysis Table*.
- The Earth Technology Corporation. 1992. *Analytical Results for Selected Boreholes in Site 43*.