

LOAN DOCUMENT

PHOTOGRAPH THIS SHEET

①

DTIC ACCESSION NUMBER

LEVEL

INVENTORY

2 Parts

Bioventing Pilot Test Work Plan . . .

DOCUMENT IDENTIFICATION

mac 93

DISTRIBUTION STATEMENT A
Approved for Public Release
Distribution Unlimited

DISTRIBUTION STATEMENT

ACCESSION FOR	
NTIS	GRAM <input type="checkbox"/>
DTIC	TRAC <input type="checkbox"/>
UNANNOUNCED	
JUSTIFICATION	
BY	
DISTRIBUTION/	
AVAILABILITY CODES	
DISTRIBUTION	AVAILABILITY AND/OR SPECIAL
A-1	

DISTRIBUTION STAMP

DATE ACCESSIONED

DATE RETURNED

20001122 052

DATE RECEIVED IN DTIC

REGISTERED OR CERTIFIED NUMBER

PHOTOGRAPH THIS SHEET AND RETURN TO DTIC-FDAC

H
A
N
D
L
E

W
I
T
H

C
A
R
E

File Copy

PART I

**Bioventing Pilot Test Work Plan for
Portions of Site 16 and Site 21
Edwards AFB, California**

PART II

**Draft Bioventing Pilot Test Interim Results Report
for Portions of Site 16 and Site 21
Edwards AFB, California**

Prepared For

**Air Force Center for Environmental Excellence
Brooks AFB, Texas**

and

Edwards AFB, California

ES

Engineering-Science, Inc.

March 1993

1700 BROADWAY, SUITE 900
DENVER, COLORADO 80290

ES ENGINEERING-SCIENCE

DEFENSE TECHNICAL INFORMATION CENTER REQUEST FOR SCIENTIFIC AND TECHNICAL REPORTS

Title AFCEE Collection

1. Report Availability (Please check one box)

- This report is available. Complete sections 2a - 2f.
- This report is not available. Complete section 3.

2a. Number of Copies Forwarded

1 each

2b. Forwarding Date

July/2000

2c. Distribution Statement (Please check ONE box)

DoD Directive 5230.24, "Distribution Statements on Technical Documents," 18 Mar 87, contains seven distribution statements, as described briefly below. Technical documents MUST be assigned a distribution statement.

- DISTRIBUTION STATEMENT A: Approved for public release. Distribution is unlimited.
- DISTRIBUTION STATEMENT B: Distribution authorized to U.S. Government Agencies only.
- DISTRIBUTION STATEMENT C: Distribution authorized to U.S. Government Agencies and their contractors.
- DISTRIBUTION STATEMENT D: Distribution authorized to U.S. Department of Defense (DoD) and U.S. DoD contractors only.
- DISTRIBUTION STATEMENT E: Distribution authorized to U.S. Department of Defense (DoD) components only.
- DISTRIBUTION STATEMENT F: Further dissemination only as directed by the controlling DoD office indicated below or by higher authority.
- DISTRIBUTION STATEMENT X: Distribution authorized to U.S. Government agencies and private individuals or enterprises eligible to obtain export-controlled technical data in accordance with DoD Directive 5230.25, Withholding of Unclassified Technical Data from Public Disclosure, 6 Nov 84.

2d. Reason For the Above Distribution Statement (in accordance with DoD Directive 5230.24)

2e. Controlling Office

HQ AFCEE

2f. Date of Distribution Statement Determination

15 Nov 2000

3. This report is NOT forwarded for the following reasons. (Please check appropriate box)

- It was previously forwarded to DTIC on _____ (date) and the AD number is _____
- It will be published at a later date. Enter approximate date if known. _____
- In accordance with the provisions of DoD Directive 3200.12, the requested document is not supplied because:

Print or Type Name

Laura Peña

Signature

Laura Peña

Telephone

210-536-1431

(For DTIC Use Only)

AQ Number

M01-01-0335

PART I

**BIOVENTING PILOT TEST WORK PLAN FOR
PORTIONS OF SITE 16 AND SITE 21
EDWARDS AFB, CALIFORNIA**

and

PART II

DRAFT

**BIOVENTING PILOT TEST INTERIM RESULTS REPORT FOR
PORTIONS OF SITE 16 AND SITE 21
EDWARDS AFB, CALIFORNIA**

Prepared for:

**Air Force Center for Environmental Excellence
Brooks AFB, Texas**

and

Edwards AFB, California

March 1993

by:

**Engineering-Science, Inc.
1700 Broadway, Suite 900
Denver, Colorado 80290**

CONTENTS

	<u>Page</u>
1.0 Introduction.....	I-1
2.0 Site Description.....	I-1
2.1 Site 16 - Building 1820 UST Excavation Area	I-1
2.1.1 Site Location and History	I-1
2.1.2 Site Geology	I-3
2.1.3 Site Contamination	I-3
2.2 Site 21 - Jet Engine Test Area.....	I-3
2.2.1 Site Location and History	I-3
2.2.2 Site Geology	I-6
2.2.3 Site Contaminants	I-6
3.0 Pilot Test Activities.....	I-6
3.1 Site 16 Pilot Test Layout and Construction.....	I-8
3.2 Site 21 Pilot Test Layout and Construction.....	I-12
3.3 Handling of Drill Cuttings.....	I-16
3.4 Soil and Soil Gas Sampling	I-16
3.4.1 Soil Samples	I-16
3.4.2 Soil Gas Samples	I-16
3.5 Blower System	I-17
3.6 <i>In Situ</i> Respiration Test	I-17
3.7 Air Permeability Test.....	I-17
3.8 Extended Pilot Test Bioventing System	I-17
4.0 Exceptions to Protocol Procedures	I-19
5.0 Base Support Requirements.....	I-19
6.0 Project Schedule.....	I-20
7.0 Points of Contact.....	I-20
8.0 References.....	I-21

FIGURES

<u>No.</u>	<u>Title</u>	<u>Page</u>
2.1	Former UST Area within Site 16.....	I-2
2.2	Site 16 BTEX Groundwater Plume.....	I-4
2.3	Site 21 Jet Engine Test Area Site Plan.....	I-5
2.4	Site 21 Benzene Groundwater Plume.....	I-7
3.1	Site 16 Proposed Vent Well/Monitoring Point Location.....	I-9
3.2	Site 16 Air Injection Vent Well Construction Detail	I-10
3.3	Site 16 Monitoring Point Construction Detail.....	I-11
3.4	Site 21 Proposed Vent Well/Monitoring Point Locations	I-13
3.5	Site 21 Air Injection Venting Well Construction Detail.....	I-14
3.6	Site 21 Monitoring Point Construction Detail.....	I-15
3.7	Blower System Instrumentation Diagram for Air Injection.....	I-18

DRAFT

BIOVENTING PILOT TEST WORK PLAN FOR PORTIONS OF SITE 16 AND SITE 21 EDWARDS AFB, CALIFORNIA

1.0 INTRODUCTION

This work plan presents the scope of *in situ* bioventing pilot tests for treatment of fuel-contaminated soils within Site 16 and Site 21 at Edwards Air Force Base (AFB), California. The pilot tests have three primary objectives: 1) to assess the potential for supplying oxygen throughout the contaminated soil interval, 2) to determine the rate at which indigenous microorganisms will degrade fuel when supplied with oxygen-rich soil gas, and 3) to evaluate the potential for sustaining these rates of biodegradation until fuel contamination is remediated to concentrations below regulatory standards.

The pilot tests will be conducted in two phases. During site investigation activities, the vent wells and vapor monitoring points will be installed by Engineering-Science, Inc. (ES). The initial testing phase will also include an *in situ* respiration test and an air permeability test. This initial testing is expected to take approximately 2 weeks. During the second phase, an extended pilot test bioventing system will be installed, operated, and monitored over a 1-year period.

If bioventing proves to be an effective means of remediating soil contamination at these sites, pilot test data may be used to design a full-scale remediation system and to estimate the time required for site cleanup. An added benefit of the pilot testing at the two sites is that a significant amount of the fuel contamination should be biodegraded during the 1-year pilot test, as the testing will take place within the most contaminated soils at each site.

2.0 SITE DESCRIPTIONS

2.1 Site 16 - Building 1820 UST Excavation Area

2.1.1 Site Location and History

The Building 1820 underground storage tank (UST) excavation area is located on the southwest side of Building 1820 within Site 16 (Figure 2.1). The site targeted for pilot testing is the former location of several USTs which contained gasoline, aviation fuel, and waste oil. The USTs were removed in the spring of 1991.

Contamination in the vicinity of the former USTs is believed to have derived from several sources, including the USTs and a JP-4 jet fuel release from an underground transfer line leak believed to have started in September 1983. Approximately 250,000 gallons to 300,000 gallons of fuel were lost before the pipeline leakage was detected (Engineering-Science, Inc. 1989b).

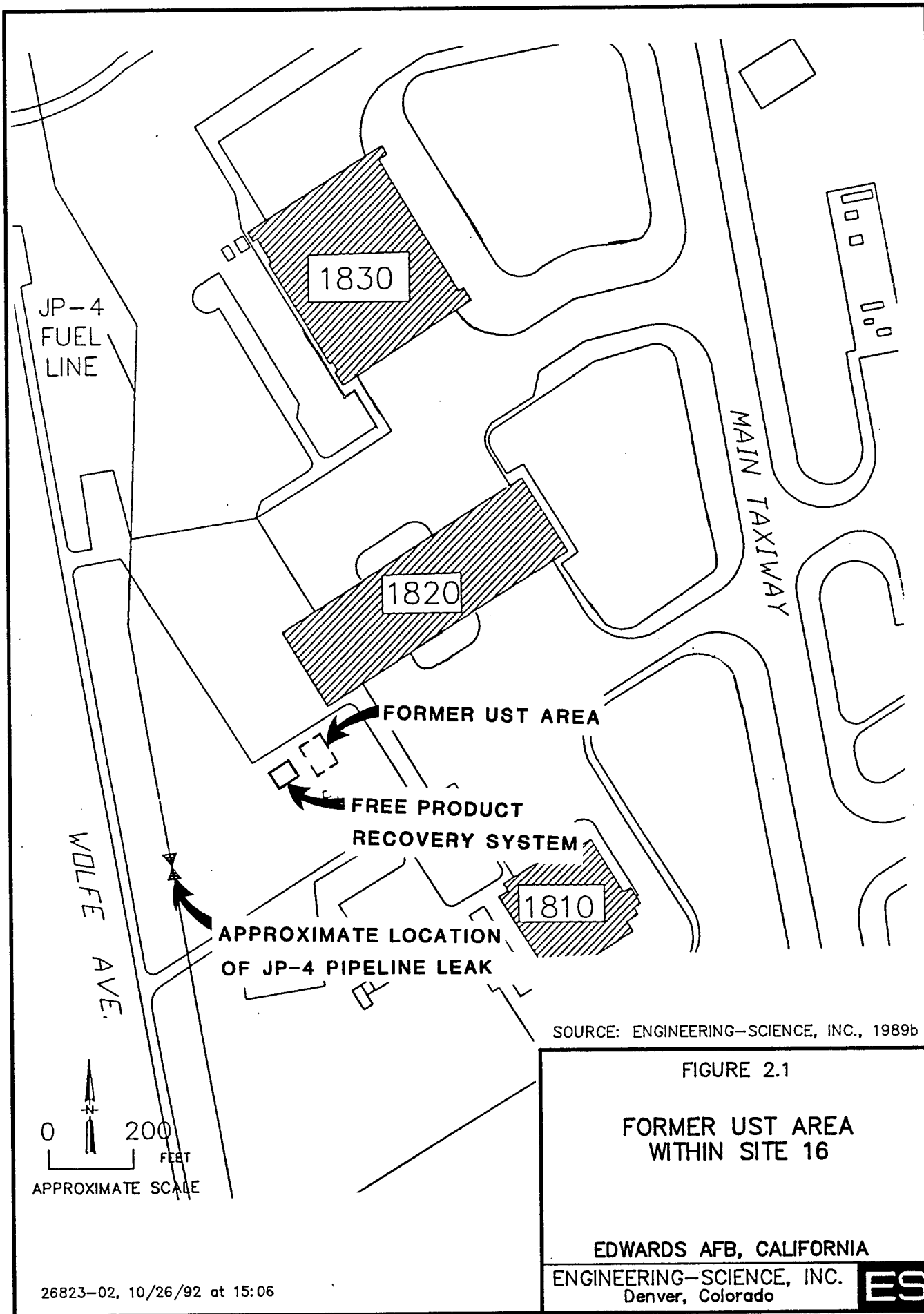

26823-02, 10/26/92 at 15:06

2.1.2 Site Geology

Because the bioventing technology is applied to the unsaturated soils, this section will primarily discuss soils above the aquifer. Soils at the pilot test site consist of mostly sandy clay material overlying weathered rock at a depth of 7 to 10 feet. Groundwater in the vicinity of the UST site is encountered at a depth of approximately 10 feet below ground surface (bgs), and generally flows northeast within Site 16 (Engineering-Science, Inc., 1989b).

Soils at this site appear to be well suited for bioventing treatment because of their generally homogeneous nature. The key to effective bioventing on this site will be to maintain high levels of oxygen within the less permeable sandy clay material. Past ES experience in bioventing in similar soil types indicates that oxygen can be distributed in these soils. Bilevel soil vapor monitoring points will be positioned in three locations to study the subsurface oxygen distribution pattern during pilot test.

2.1.3 Site Contamination

The primary contaminant at this site is JP-4 jet fuel occurring as free product on the groundwater and as soil residuals. Trichloroethene (TCE) contamination also present near Building 1820 may have resulted from a release at a TCE-use area source near Building 1810. Analyses of groundwater indicate TCE contamination in the vicinity of the UST excavation site, however TCE does not appear to be associated with soils in the proposed bioventing area.

A free product recovery system was installed and began operation in November 1987, but was subsequently shut down in December 1987, due to elevated concentrations of TCE in the discharge water. Dissolved petroleum constituents detected in alluvial groundwater (and their maximum concentrations) include benzene [15,000 micrograms per liter ($\mu\text{g}/\text{l}$)], toluene (9,700 $\mu\text{g}/\text{l}$), ethylbenzene (13,000 $\mu\text{g}/\text{l}$), and xylenes (13,000 $\mu\text{g}/\text{l}$) (BTEX). Figure 2.2 shows the BTEX groundwater plume at Site 16. The concentration of total petroleum hydrocarbons (TPH) within 100 feet of the UST site was 1,500 milligrams per liter (mg/l). Approximate fuel product thicknesses were measured at 1.4 feet and 2.9 feet at wells RW-9 and 16-17, respectively, in April 1989. Based on these data, ES has concluded that the former UST site likely contains significant petroleum hydrocarbon soil contamination which can be treated by the bioventing method. No soil samples from the UST site have been analyzed; however, soil analyses performed on samples from nearby well 16-12 at 10 feet bgs in 1985 indicated the presence of benzene [2,000 μg per kilogram ($\mu\text{g}/\text{kg}$)], toluene (300 $\mu\text{g}/\text{kg}$), and total xylenes (2,000 $\mu\text{g}/\text{kg}$) (Engineering-Science Inc., 1989b).

2.2 Site 21 - Jet Engine Test Area

2.2.1 Site Location and History

The jet engine test area is located northwest of Building 1899 at Site 21 (Figure 2.3). Building 1899 is the logistical center for a jet engine test cell. Two 10,000-gallon JP-4/JP-5 USTs supply this facility via a buried jet fuel distribution pipeline. After fuel was discovered seeping through cracks in the paved surface west of the test cell, the pipeline was rerouted and the tanks were kept in service. In 1989,

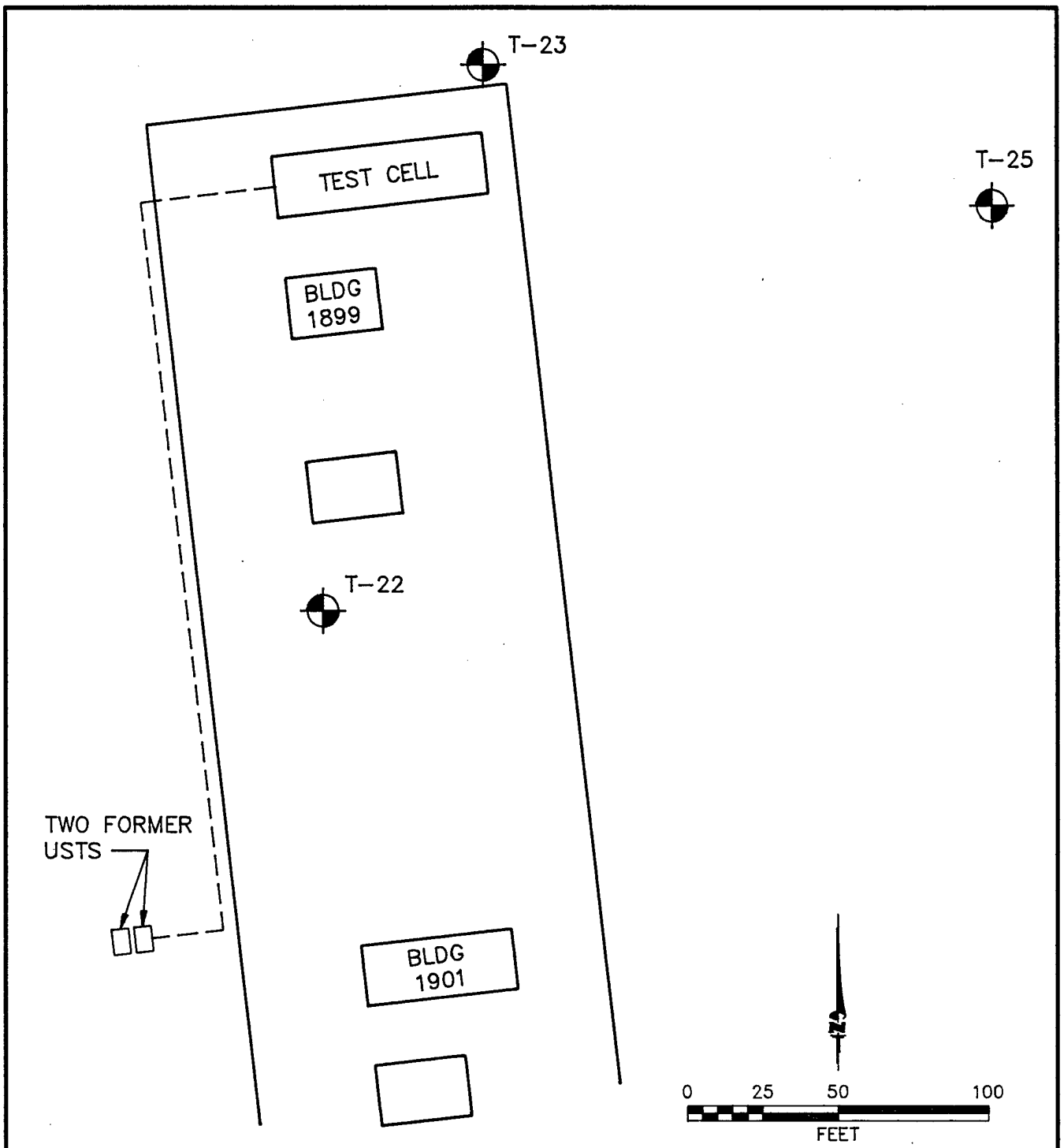

TWO FORMER USTS

LEGEND

T-25



EXISTING MONITORING WELL



FORMER JP-4 PIPELINE

SOURCE: ENGINEERING-SCIENCE, INC., 1989d

FIGURE 2.3

SITE 21
JET ENGINE TEST AREA
SITE PLAN

EDWARDS AFB, CALIFORNIA

ENGINEERING-SCIENCE, INC.
Denver, Colorado



Westech Environmental Drilling drilled soil boreholes near both ends of the tanks. The soil was found to be discolored, indicating that the tanks had leaked. The tanks were then taken out of service, and two 5,000-gallon aboveground replacement tanks were installed to supply the test cell.

2.2.2 Site Geology

Bioventing technology is applied to the unsaturated soils above the aquifer. North of Building 1899, groundwater is encountered at a depth of approximately 15 feet and flows in an easterly direction across the site. The groundwater is contained in unconsolidated alluvium and weathered bedrock under confined (water table) conditions. The pilot test area soils are alluvial soils consisting mostly of sand and silt (Engineering-Science, Inc., 1989a). The generally homogeneous, sandy nature of the soils at this site appear to be well suited to bioventing treatment.

2.2.3 Site Contaminants

Although the extent of contamination has not been fully defined, the site is thought to be contaminated with JP-4 fuel from the former onsite USTs and also possibly from pipeline leaks. Based on results of groundwater sampling at the site, ES identified a benzene plume (Figure 2.4). Benzene concentrations in groundwater ranged from 14 $\mu\text{g}/\text{l}$ at well 21-T23, to 2,800 $\mu\text{g}/\text{l}$ at 21-T22.

Fuel-contaminated soil is known to exist along the JP-4 fuel pipeline and beneath the jet engine test cell pad. The bioventing pilot test has been tentatively sited along the northeast corner of the test pad; however, if initial soil gas measurements determine that another site area is more contaminated, the pilot test will be relocated to the area of the greatest soil contamination.

3.0 PILOT TEST ACTIVITIES

The purpose of this section is to describe the work that will be performed by ES within Sites 16 and 21. A soil gas survey will be performed at both bioventing pilot test sites in order to identify the areas of highest contamination and to determine the optimal location of the vent well (VW). Activities that will be performed at each site include siting and construction of a central air-injection VW and three vapor monitoring points (MPs), conducting an *in situ* respiration test and an air permeability test, and the operation and monitoring of an extended bioventing pilot test. Soil and soil gas sampling procedures and the blower configuration that will be used to inject air (oxygen) into contaminated soils through the VW are also discussed in this section.

The bioventing technology is intended to remediate contamination only in the unsaturated zone. Therefore, pilot test activities will be confined mainly to unsaturated soils. The central VWs may be completed to approximately 1 foot below the current groundwater table to provide oxygen to the deepest levels of the unsaturated zone, in case the groundwater table recedes due to pressurization or natural fluctuation. No dewatering will take place during the pilot tests. Existing monitoring wells will not be used as primary air injection or vapor monitoring wells. However, monitoring wells which have a portion of their screened interval above

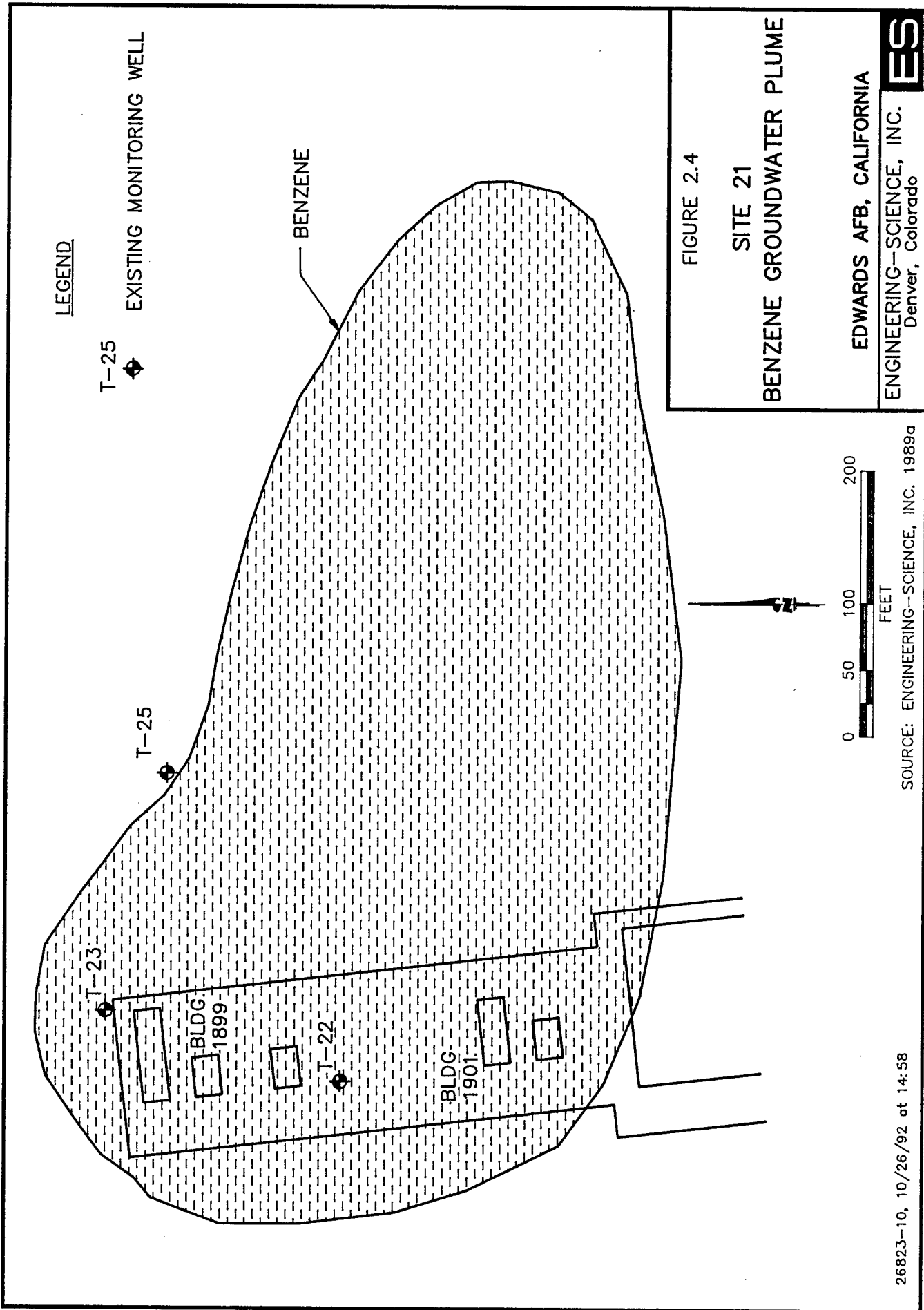

the water table may be used as vapor MP points or to measure the composition of background soil gas.

3.1 SITE 16 PILOT TEST LAYOUT AND CONSTRUCTION

A general description of criteria for siting a central VW and vapor MPs are included in the protocol document (Hinchee et al., 1992). Figure 3.1 illustrates the proposed locations of the central VW and MPs within Site 16. The final locations of these wells may vary slightly from the proposed locations if significant fuel contamination is not observed in the boring for the central VW. Based on site investigation data, the central VW should be located near the Building 1820 UST excavation site. Soils in this area are expected to be oxygen depleted (<2%) due to high hydrocarbon levels, and increased biological activity should be stimulated by oxygen-rich soil gas injection during pilot test operations.

Due to the relatively shallow depth of contamination at the test area and the experience that ES has had with this soil type, the potential radius of venting influence around the central VW is expected to be 35 to 40 feet. Three vapor MPs (MPA, MPB, and MPC) will be located within a 35-foot radial distance of the central VW. A fourth vapor MP, to be located upgradient of the site, will be used to measure background levels of oxygen and carbon dioxide and to determine if natural carbon sources are contributing to oxygen uptake during the *in situ* respiration test. The location of this background MP will be determined during the soil gas survey. Additional details on *in situ* respiration test procedures are found in Section 5.7 of the protocol document (Hinchee et al., 1992).

The VW will be constructed of 4-inch inside-diameter (ID) Schedule 40 polyvinyl chloride (PVC), with a 5-foot interval of 0.04-inch slotted screen set at 6 to 11 feet bgs. Flush-threaded PVC casing and screen with no organic solvents or glues will be used. The filter pack will be clean, well rounded silica sand with a 6-9 grain size and will be placed in the annular space of the screened interval. A 5-foot layer of bentonite will be placed directly over the filter pack. The first 6 inches of bentonite will consist of bentonite pellets hydrated in place with potable water. This layer of pellets will prevent the addition of bentonite slurry from saturating the filter pack. The remaining 42 inches of bentonite will be fully hydrated and mixed aboveground, and the slurry will be tremied into the annular space to produce an air-tight seal above the screened interval. The annular space to ground surface will be filled with approximately 1 foot of bentonite/cement grout. A complete seal is critical to prevent injected air from short circuiting to the surface during the bioventing test. Figure 3.2 illustrates the proposed VW construction for this site.

A typical multi-depth vapor MP installation for this site is shown in Figure 3.3. Soil gas oxygen and carbon dioxide concentrations will be monitored at depth intervals of 4.5 to 5.5 feet and 9.5 to 10.5 feet at each location. Multi-depth monitoring will confirm that the entire soil profile is receiving oxygen and allow measurement of fuel biodegradation rates at each depth. The spaces between monitoring intervals will be sealed with bentonite to isolate the intervals. As in the central VW, several inches of bentonite pellets will be used to shield the filter pack

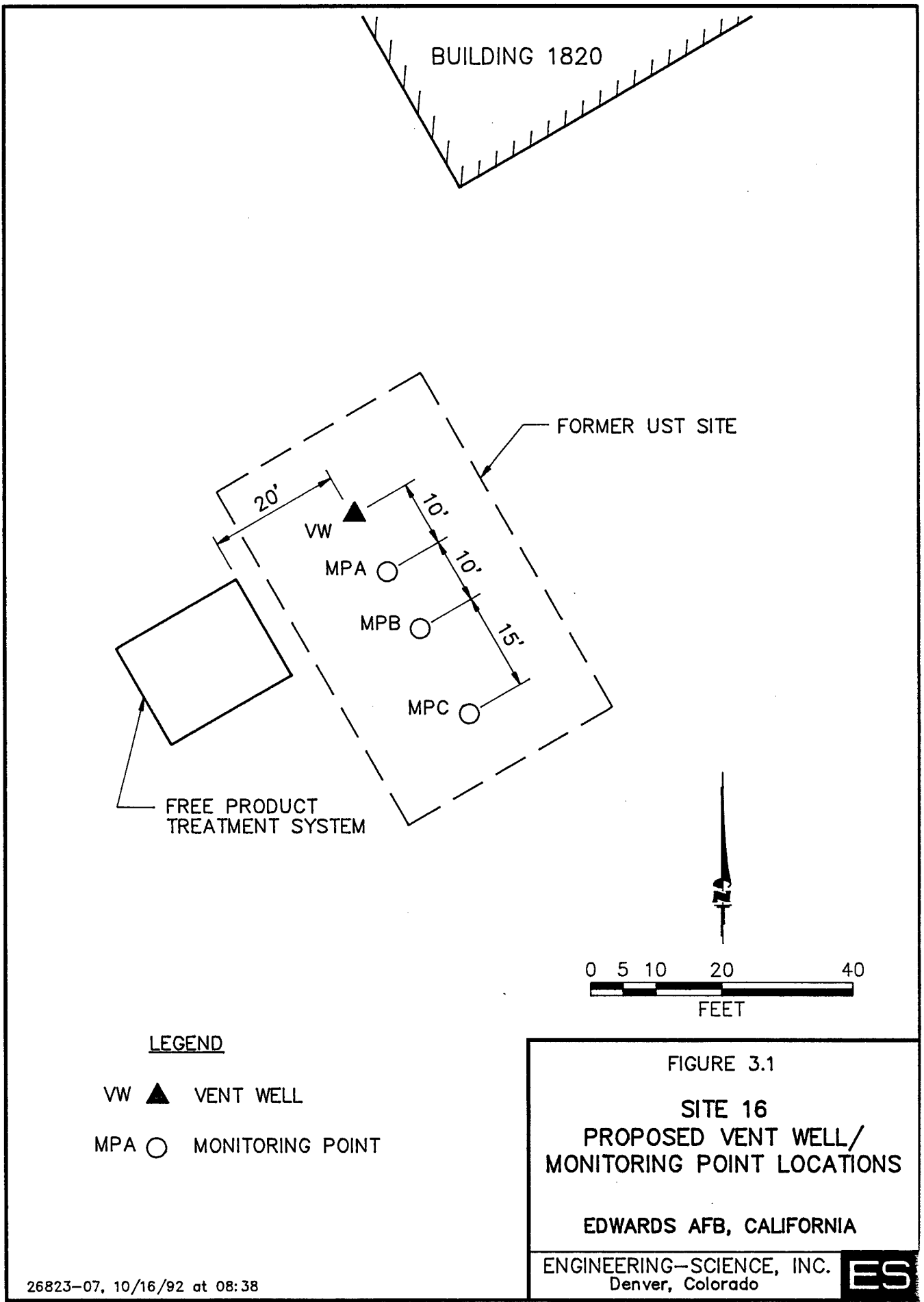

LEGEND

- VW ▲ VENT WELL
- MPA ○ MONITORING POINT

FIGURE 3.1
 SITE 16
 PROPOSED VENT WELL/
 MONITORING POINT LOCATIONS
 EDWARDS AFB, CALIFORNIA
 ENGINEERING—SCIENCE, INC.
 Denver, Colorado **ES**

26823-07, 10/16/92 at 08:38

2" DIAMETER SCH 40
PVC HEADER SLOPED
TO WELL

← FROM BLOWER

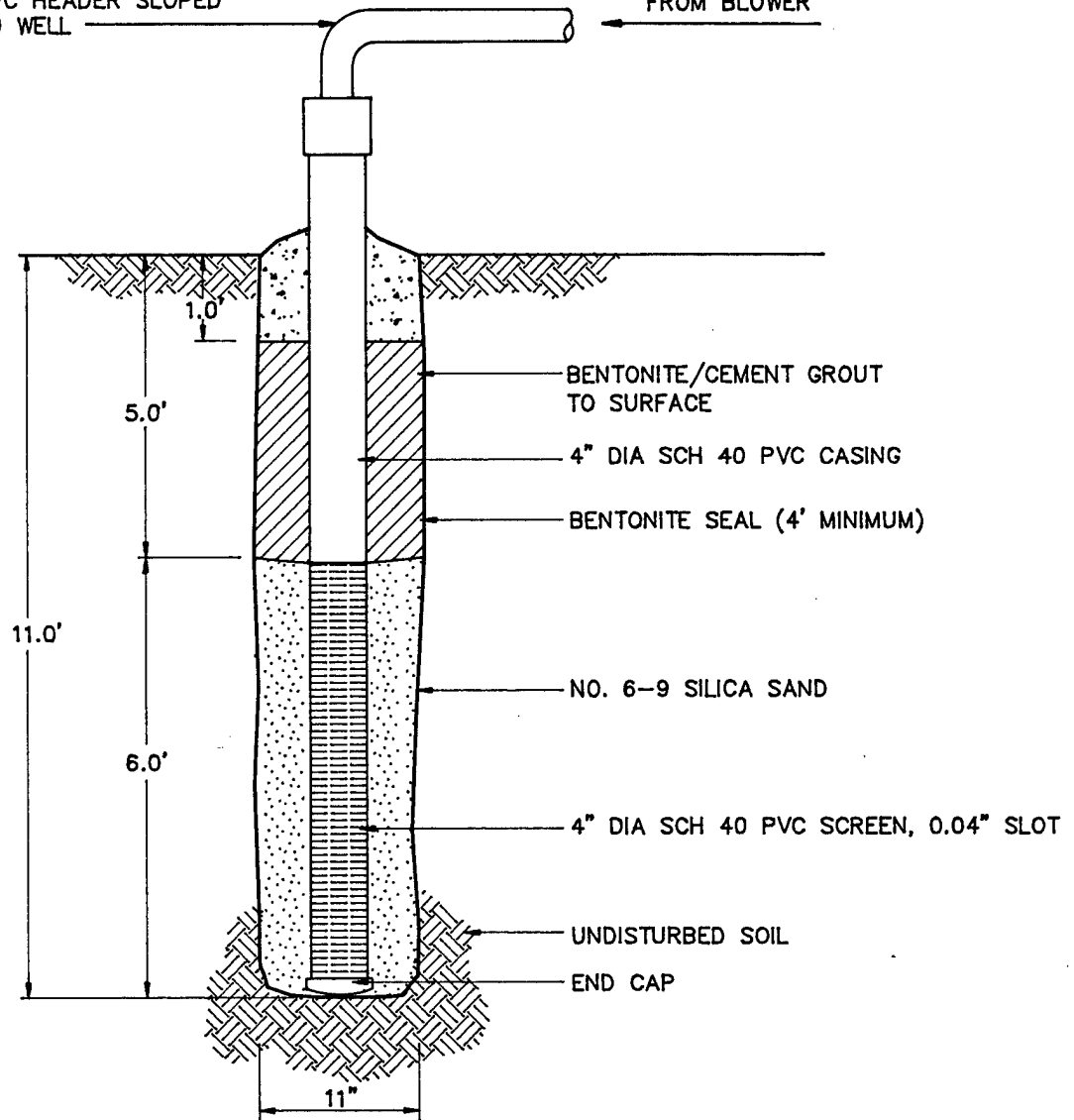

NOT TO SCALE

FIGURE 3.2
SITE 16
AIR INJECTION VENT WELL
CONSTRUCTION DETAIL

EDWARDS AFB, CALIFORNIA

ENGINEERING-SCIENCE, INC.
Denver, Colorado

ES

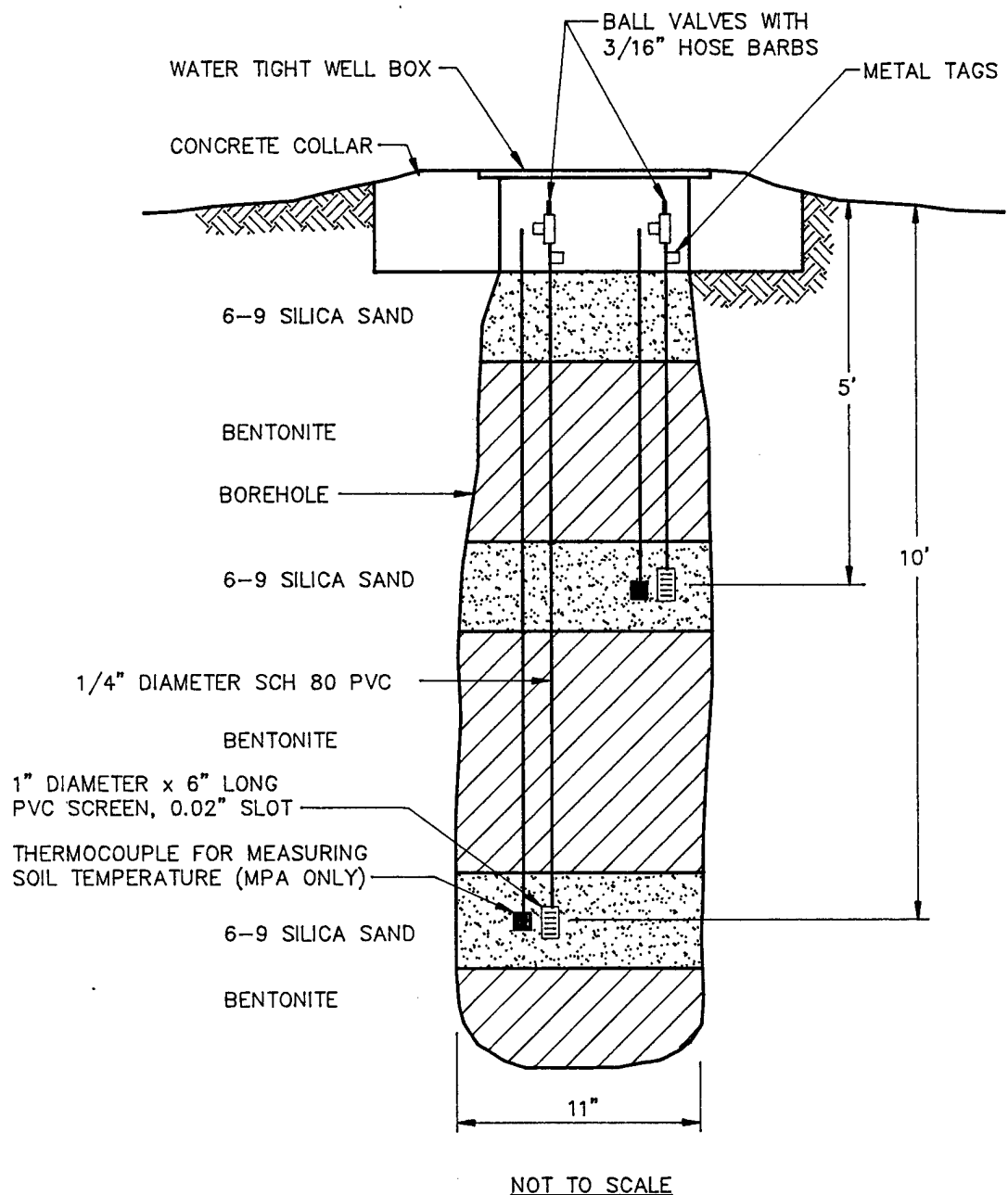

FIGURE 3.3

SITE 16
MONITORING POINT
CONSTRUCTION DETAIL

EDWARDS AFB, CALIFORNIA

ENGINEERING-SCIENCE, INC.
Denver, Colorado

ES

from rapid infiltration of bentonite slurry additions. Additional details on VW and MP construction are provided in Section 4 of the protocol document (Hinchee et al., 1992).

3.2 SITE 21 PILOT TEST LAYOUT AND CONSTRUCTION

Figure 3.4 illustrates the proposed locations of the central VW and MPs at the jet engine test area within Site 21. The final locations of these wells may vary from the proposed locations if significant fuel contamination is not observed in the borehole for the central VW. Based on available site investigation data, the central VW has been sited adjacent to the asphalt pad northwest of Building 1899 and the test cell. Soils in this area are expected to be oxygen depleted (<2%) due to known fuel contamination in the area, and increased biological activity should be stimulated by oxygen-rich soil gas injection during pilot test operations.



Due to the relatively shallow depth of contamination at this site and ES experience in bioventing in similar soils, the potential radius of venting influence around the central VW is expected to be 35 to 45 feet. Three vapor MPs (MP1, MP2, and MP3) will be located within a 40-foot radial distance of the central VW. A fourth vapor MP, to be located upgradient of the site, will be used to measure background levels of oxygen and carbon dioxide and to determine if natural carbon sources are contributing to oxygen uptake during the *in situ* respiration test. The location of this background MP will be determined during the soil gas survey.

The VW will be constructed of 4-inch ID Schedule 40 PVC, with a 10-foot interval of 0.04-inch slotted screen set at 6 to 16 feet bgs. Flush-threaded PVC casing and screen with no organic solvents or glues will be used. The filter pack will be clean, well rounded silica sand with a 6-9 grain size, and will be placed in the annular space of the screened interval. A 5-foot layer of bentonite will be placed directly over the filter pack. The first 6 inches of bentonite will consist of pellets hydrated in place with potable water. This layer of pellets will prevent the addition of bentonite slurry from saturating the filter pack. The remaining 54 inches of bentonite will be fully hydrated and mixed aboveground, and the slurry will be tremied into the annular space to produce an air-tight seal above the screened interval. The VW will be completed to ground surface with a bentonite/cement grout. A complete seal is critical to prevent injected air from short circuiting to the surface during the bioventing test. Figure 3.5 illustrates the proposed VW construction for this site.

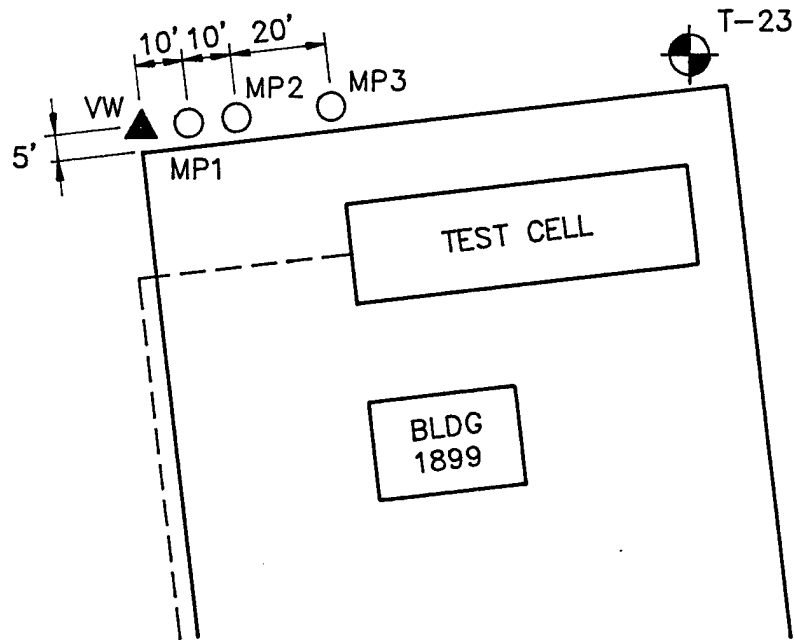
A typical multi-depth vapor MP installation for the jet engine test area of Site 21 is shown in Figure 3.6. Soil gas oxygen and carbon dioxide concentrations will be monitored at depth intervals of 4.5 to 5.5 feet, 8.5 to 9.5 feet, and 12.5 to 13.5 feet at each location. Multi-depth monitoring will confirm that the entire soil profile is receiving oxygen and allow measurement of fuel biodegradation rates at each depth. The spaces between monitoring intervals will be sealed with bentonite to isolate the intervals. As in the central VW, several inches of bentonite pellets will be used to shield the filter pack from rapid infiltration of bentonite slurry additions.



LEGEND

- T-25  EXISTING MONITORING WELL
- VW  VENT WELL
- MP1  MONITORING POINT
- FORMER PIPELINE FROM USTS



SOURCE: ENGINEERING-SCIENCE, INC., 1989a

FIGURE 3.4
SITE 21
**PROPOSED VENT WELL/
 MONITORING POINT LOCATIONS**

EDWARDS AFB, CALIFORNIA

ENGINEERING-SCIENCE, INC.
 Denver, Colorado



2" DIAMETER SCH 40
PVC HEADER SLOPED
TO WELL

← FROM BLOWER

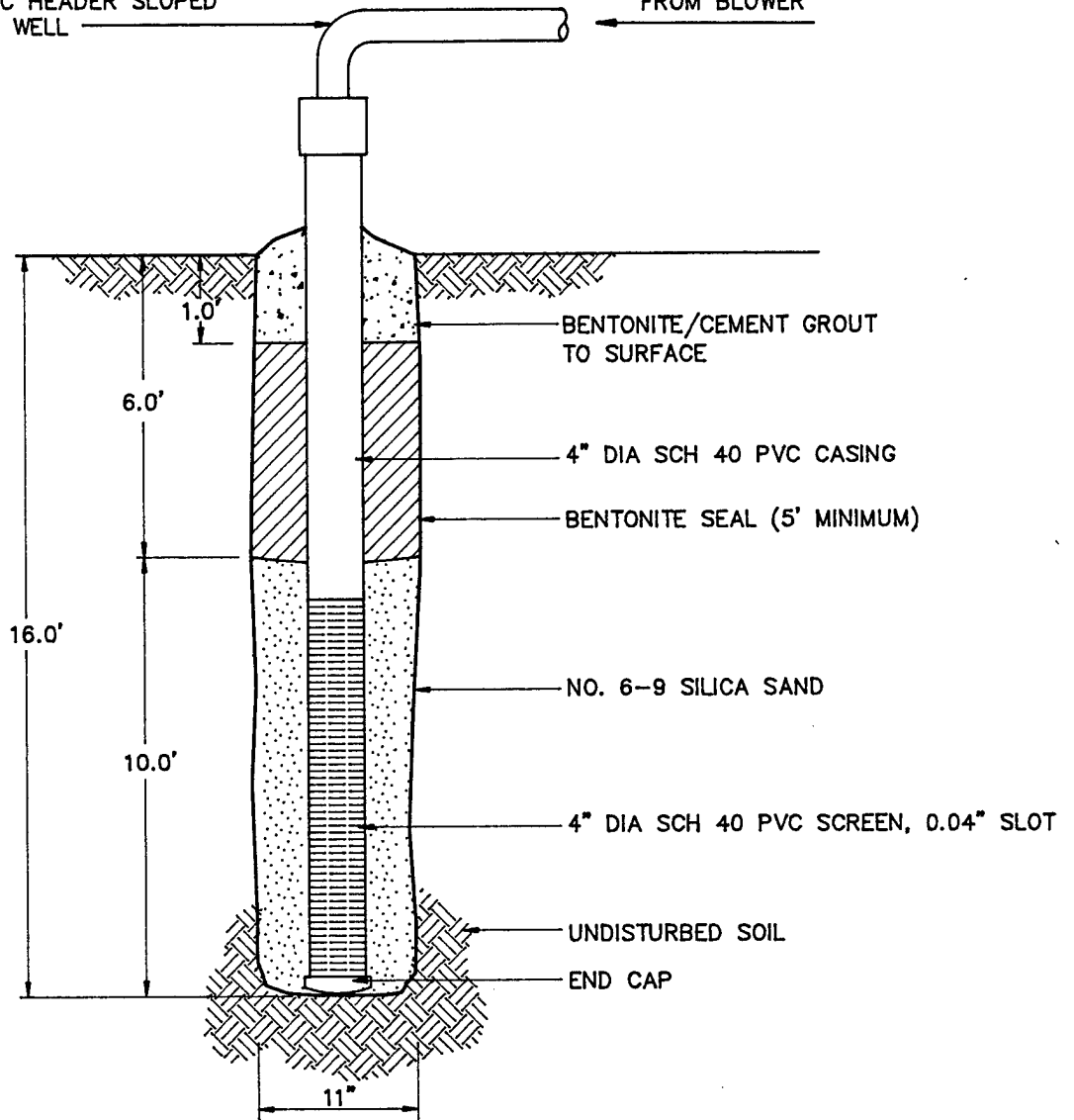

NOT TO SCALE

FIGURE 3.5

SITE 21
AIR INJECTION VENTING WELL
CONSTRUCTION DETAIL

EDWARDS AFB, CALIFORNIA

ENGINEERING-SCIENCE, INC.
Denver, Colorado

ES

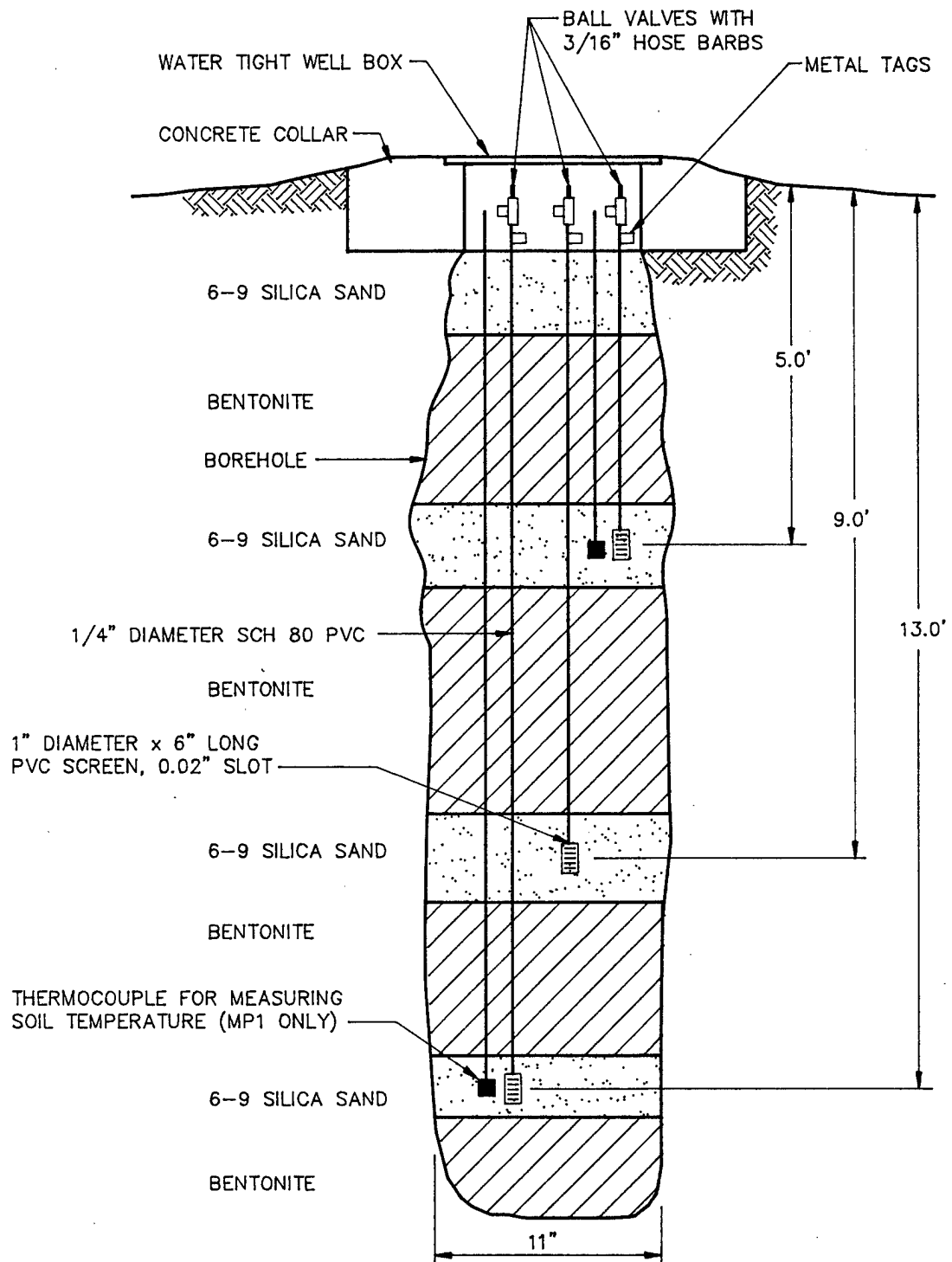

FIGURE 3.6

SITE 21
 MONITORING POINT
 CONSTRUCTION DETAIL

EDWARDS AFB, CALIFORNIA

ENGINEERING-SCIENCE, INC.
 Denver, Colorado



Additional details on VW and MP construction are provided in Section 4 of the protocol document (Hinchee et al., 1992).

3.3 Handling of Drill Cuttings

Drill cuttings from all borings will be screened in the field with a total hydrocarbon vapor analyzer (see protocol document, Section 4.5.2). Cuttings with petroleum contamination over 400 parts per million, volume per volume (ppmv) will be collected in U.S. Department of Transportation (DOT) approved containers. The containers will be labeled and placed in the Edwards AFB hazardous material storage area. These drill cuttings will become the responsibility of Edwards AFB and will be analyzed, handled, and disposed of in accordance with the current procedures for ongoing remedial investigations. Cuttings with petroleum contamination of less than 400 ppmv will be spread on the ground surface within the pilot test area, unless the base sampling and analysis protocol requires that all cuttings be drummed.

3.4 Soil and Soil Gas Sampling

3.4.1 Soil Samples

Three soil samples will be collected from each pilot test area during the installation of the VW and MPs. Sampling procedures will follow those outlined in the protocol document. One sample will be collected from the most contaminated interval of each VW boring, and one sample will be collected from the interval of highest apparent contamination in each of the borings for the two MPs closest to the VW. Soil samples will be analyzed for total recoverable petroleum hydrocarbons (TRPH), BTEX, soil moisture, pH, particle sizing, alkalinity, total iron, and nutrients.

Samples for TRPH and BTEX analysis will be collected using a split-spoon sampler containing brass tube liners. Soil samples collected in the brass tubes for TRPH and BTEX analyses will be immediately trimmed, and the ends will be sealed with aluminum foil or Teflon[®] fabric held in place by plastic caps. Soil samples collected for physical parameter analyses will be placed into glass sample jars or other appropriate sample containers specified in the base sample handling plan. Soil samples will be labelled following the nomenclature specified in the protocol document (Section 5), wrapped in plastic, and placed in a cooler for shipment. A chain-of-custody form will filled out, and the cooler will be shipped to the ES laboratory in Berkeley, California for analysis. This laboratory has been audited by the Air Force and meets all quality assurance/quality control and certification requirements for the State of California.

3.4.2 Soil Gas Samples

A total hydrocarbon vapor analyzer will be used during drilling to screen split-spoon samples for intervals of significant fuel contamination. Initial soil gas samples will be collected in SUMMA[®] canisters in accordance with the Bioventing Field Sampling Plan (Engineering-Science, Inc., 1992) from the VW and from the MPs closest to and furthest from the VW. These soil gas samples will be used to predict potential air emissions, to determine the reduction in BTEX and total volatile

hydrocarbons (TVH) during the 1-year test, and to detect any migration of these vapors from the source area.

Soil gas sample canisters will be placed in a small cooler and packed with foam pellets to prevent excessive movement during shipment. Samples will not be sent on ice to prevent condensation of hydrocarbons. A chain-of-custody form will be filled out, and the cooler will be shipped to the Air Toxics laboratory in Rancho Cordova, California for analysis.

3.5 Blower System

A 3-horsepower positive-displacement blower capable of injecting up to 30 standard cubic feet per minute (scfm) at 8 pounds per square inch (psi) will be used to conduct the initial air permeability test and *in situ* respiration tests. Figure 3.7 is a schematic of a typical air injection system used for pilot testing. The maximum power requirement anticipated for this pilot test is a 230-volt, single-phase, 30-amp service. Additional details on power supply requirements are described in Section 5.0, Base Support Requirements.

3.6 In Situ Respiration Test

The objective of the *in situ* respiration tests is to determine the rate at which soil bacteria degrade petroleum hydrocarbons. Respiration tests will be performed at every vapor MP where bacterial biodegradation of hydrocarbons is indicated by low oxygen levels and elevated carbon dioxide concentrations in the soil gas. Air will be injected into each MP depth interval containing low levels (<2%) of oxygen. A 20-hour air injection period will be used to oxygenate local contaminated soils. At the end of the 20-hour air injection period, the air supply will be cut off, and oxygen and carbon dioxide levels will be monitored for the following 48 to 72 hours. The decline in oxygen and increase in carbon dioxide concentrations over time will be used to estimate rates of bacterial degradation of fuel residuals. Helium will also be injected into one or two MPs to estimate oxygen diffusion rates in site soils. This estimated rate of diffusion will be used to separate the oxygen diffusion and biodegradation components of the measured rate of oxygen consumption.

3.7 Air Permeability Test

The objective of the air permeability test is to determine the extent of the subsurface that can be oxygenated using one air injection VW. Air will be injected into the 4-inch-diameter VW using the blower unit, and pressure response will be measured at each MP with differential pressure gages to determine the region influenced by the unit. Oxygen will also be monitored in the MPs to ascertain whether oxygen levels in the soil increase as the result of air injection. One air permeability test lasting 4 to 8 hours will be performed.

3.8 Extended Pilot Test Bioventing System

Bioventing systems for extended, 1-year pilot testing will be installed at the Site 16 and Site 21 test sites. At each site, the base will be requested to provide a power pole with a 230-volt single-phase 30-amp breaker box, one 230-volt receptacle, and

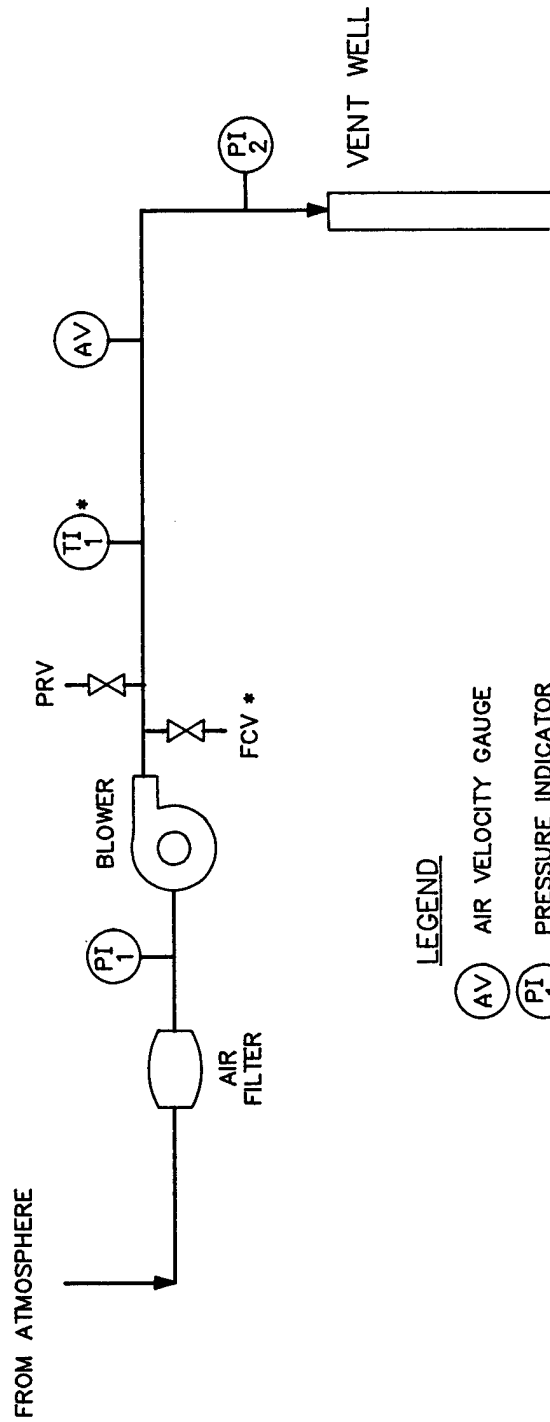

LEGEND

- (AV) AIR VELOCITY GAUGE
- (PI 1) PRESSURE INDICATOR
- (TI 1) TEMPERATURE INDICATOR
- FCV FLOW CONTROL VALVE
- PRV PRESSURE RELIEF VALVE
- * OPTIONAL

FIGURE 3.7

BLOWER SYSTEM
INSTRUMENTATION DIAGRAM
FOR AIR INJECTION

EDWARDS AFB, CALIFORNIA

ENGINEERING-SCIENCE, INC.
Denver, Colorado



two 115-volt receptacles. Depending on the availability of a base electrician, a base electrician or a licensed electrician subcontracted to ES will assist in the final wiring of the blowers to the breaker. The blower will be housed in a small, prefabricated shed to provide protection from the weather.

The system will be in operation for 1 year, and every 6 months ES personnel will conduct *in situ* respiration tests to monitor the long-term performance of this bioventing system. Weekly system checks will be performed by Edwards AFB personnel. If required, any major maintenance of the blower unit may be performed by ES personnel. Detailed blower system information and a maintenance schedule will be included in the operation and maintenance (O&M) manual provided to the base. More detailed information regarding the extended pilot test procedures can be found in the protocol document (Hinchee et al., 1992).

4.0 EXCEPTIONS TO PROTOCOL PROCEDURES

The procedures that will be used to measure the air permeability of the soil and *in situ* respiration rates are described in Sections 4 and 5 of the protocol document (Hinchee et al., 1992). No exceptions to the protocol document procedures are anticipated.

5.0 BASE SUPPORT REQUIREMENTS

The following base support is needed prior to the arrival of the drilling subcontractor and the ES pilot test team:

- Assistance in obtaining drilling and digging permits. Assist in obtaining any necessary permits should either central VW be completed below the groundwater table.
- Installation of a power pole and breaker box at each site. The pole should include a 230-volt, 30-amp, single-phase service and a breaker box with one 230-volt receptacle and two 115-volt receptacles. The pole should be located within 10 to 15 feet of the central VW location at each site. A pole may not be required at Site 16 due to the close proximity of a power source at the free product recovery system, however, the power service and breaker box will still be required.
- Provision of any paperwork required to obtain gate passes and security badges for approximately three ES employees, two drillers, and an electrician (if a base electrician is not available). Vehicle passes will be needed for one truck and one drill rig.

During the initial testing, the following base support is needed:

- Twelve square feet of desk space and a telephone in a building located as close to the site as practical.
- The use of a facsimile machine for transmitting 15 to 20 pages of test results.
- A decontamination pad where the driller can clean augers between borings.

- Acceptance of responsibility by Edwards AFB for drill cuttings from VW and MP borings, including any drum sampling to determine hazardous waste status. ES will place drill cuttings in a DOT-approved container and transport them to the Edwards AFB hazardous materials area.

During the 1-year extended pilot test, base personnel will be required to perform the following activities:

- Check the blower system once per week to ensure that it is operating, to record the air-injection pressure, and to replace the air filter, if required. ES will provide a brief training session on these procedures and a system O&M manual.
- If the blower stops working, notify Mr. Doug Downey or Ms. Gail Saxton, ES-Denver, at (303)831-8100.
- Arrange site access for an ES technician to conduct *in situ* respiration tests approximately 6 months and at 1 year after the initial pilot test.

6.0 PROJECT SCHEDULE

The following schedule is contingent upon timely approval of this pilot test work plan.

<u>Event</u>	<u>Date</u>
Draft Test Work Plan to AFCEE/Edwards AFB	28 October 1992
Begin Initial Pilot Test	30 November 1992
Interim Results Report	21 January 1993
Second Respiration Test	May 1993
Final Respiration Test	November 1993
Final Results Report	

7.0 POINTS OF CONTACT

Robert W. Wood/Steve Daneke
70 N. Wolfe Ave.
Edwards AFB, CA 93524-6225
(805) 277-1401

Major Ross Miller/Mr. Sam Taffinder
AFCEE/EST
2504 D Drive Ste 3
Brooks AFB, TX 78235-5103
(800) 821-4528 ext. 282, 230

Mr. Doug Downey
Engineering-Science, Inc.
1700 Broadway, Suite 900
Denver, CO. 80290
(303) 831-8100
Fax (303) 831-8208

8.0 REFERENCES

- Engineering-Science, Inc. 1992. *Field Sampling Plan for AFCEE Bioventing*. Denver, Colorado.
- Engineering-Science, Inc. 1989a. *Draft Remedial Investigation Report Site 21, Edwards AFB, California, Volume I*. Pasadena, California. June.
- Engineering-Science, Inc. 1989b. *IRP Site 16 Assessment, Edwards AFB, California, Volume I*. Atlanta, Georgia. June.
- Hinchee, R. E., S. K. Ong, R. N. Miller, D. C. Downey, and R. Frandt. 1992. *Test Plan and Technical Protocol for a Field Treatability Test for Bioventing*. January.

PART II
DRAFT
INTERIM PILOT TEST RESULTS REPORT
FOR
PORTIONS OF SITE 16 AND SITE 21
EDWARDS AFB, CALIFORNIA

March 1993

Prepared for:

Air Force Center for Environmental Excellence
Brooks AFB, Texas

and

Edwards AFB, California

by:

Engineering-Science, Inc.
1700 Broadway, Suite 900
Denver, Colorado

CONTENTS

PART II - DRAFT INTERIM PILOT TEST RESULTS REPORT FOR PORTIONS OF SITE 16 AND SITE 21 EDWARDS AFB, CALIFORNIA

	<u>Page</u>
1.0 Site 16.....	II-1
1.1 Pilot Test Design and Construction.....	II-1
1.1.1 Air Injection Vent Well.....	II-1
1.1.2 Monitoring Points.....	II-5
1.1.3 Blower Unit.....	II-5
1.2 Soil and Soil Gas Sampling Results.....	II-5
1.2.1 Soil Sampling Results.....	II-5
1.2.2 Soil Gas Sampling Results.....	II-8
1.3 Pilot Test Results.....	II-8
1.3.1 Exceptions to Test Protocol Procedures.....	II-8
1.3.2 Initial Soil Gas Chemistry.....	II-8
1.3.3 Air Permeability.....	II-10
1.3.4 Oxygen Influence.....	II-10
1.3.5 <i>In Situ</i> Respiration Rates.....	II-10
1.3.6 Potential Air Emissions.....	II-14
1.4 Recommendations.....	II-14
2.0 Site 21.....	II-20
2.1 Pilot Test Design and Construction.....	II-20
2.1.1 Air Injection Vent Well.....	II-20
2.1.2 Monitoring Points.....	II-24
2.1.3 Blower Unit.....	II-24
2.2 Soil and Soil Gas Sampling Results.....	II-24
2.2.1 Soil Sampling Results.....	II-24
2.2.2 Soil Gas Sampling Results.....	II-28
2.3 Pilot Test Results.....	II-28
2.3.1 Exceptions to Test Protocol Procedures.....	II-28
2.3.2 Initial Soil Gas Chemistry.....	II-28
2.3.3 Air Permeability.....	II-28
2.3.4 Oxygen Influence.....	II-31
2.3.5 <i>In Situ</i> Respiration Rates.....	II-31
2.3.6 Potential Air Emissions.....	II-40
2.4 Recommendations.....	II-40
3.0 References.....	II-41

APPENDIX A O&M Instructions

APPENDIX B Geologic Boring Logs and Chain-of-Custody Forms

CONTENTS (Continued)

TABLES

<u>No.</u>	<u>Title</u>	<u>Page</u>
<u>Site 16:</u>		
1.1	Soil and Soil Gas Analytical Results	II-9
1.2	Initial Soil Gas Chemistry	II-11
1.3	Pressure Response During the Air Permeability Test	II-12
1.4	Influence of Air Injection at Vent Well on Monitoring Point Oxygen Levels	II-13
1.5	Oxygen Utilization Rates	II-15
<u>Site 21:</u>		
2.1	Soil and Soil Gas Analytical Results	II-27
2.2	Initial Soil Gas Chemistry	II-29
2.3	Pressure Response During the Air Permeability Test	II-30
2.4	Influence of Air Injection at Vent Well on Monitoring Point Oxygen Levels	II-32
2.5	Oxygen Utilization Rates	II-33

FIGURES

<u>No.</u>	<u>Title</u>	<u>Page</u>
<u>Site 16:</u>		
1.1	Record Drawing Site Plan	II-2
1.2	Hydrogeologic Cross Section	II-3
1.3	Record Drawing Air Injection Vent Well Construction Detail	II-4
1.4	Record Drawing Monitoring Point Construction Detail	II-6
1.5	Record Drawing Blower System for Air Injection	II-7
1.6	Respiration Test, Vent Well	II-16
1.7	Respiration Test, MPA-9	II-17
1.8	Respiration Test, MPB-9	II-18
1.9	Respiration Test, MPC-9	II-19
<u>Site 21:</u>		
2.1	Record Drawing Site Plan	II-21
2.2	Hydrogeologic Cross Section	II-22
2.3	Record Drawing Injection Vent Well Construction	II-23
2.4	Record Drawing Monitoring Point Construction Detail	II-25
2.5	Record Drawing Blower System for Air Injection	II-26
2.6	Respiration Test, Vent Well	II-34
2.7	Respiration Test, MP1-11	II-35
2.8	Respiration Test, MP2-7	II-36
2.9	Respiration Test, MP2-11	II-37
2.10	Respiration Test, MP3-7	II-38
2.11	Respiration Test, MP2-11	II-39

PART II
DRAFT
INTERIM PILOT TEST RESULTS REPORT
PORTIONS OF SITE 16 AND SITE 21
EDWARDS AFB, CALIFORNIA

Initial bioventing pilot tests were completed at portions of Site 16 and Site 21 at Edwards Air Force Base (AFB), California during the period of 4 through 22 January 1993. The purpose of this Part II report is to describe the results of the initial pilot tests at Site 16 and Site 21 and to make specific recommendations for extended testing to determine the long-term impact of bioventing on site contaminants. Descriptions of the history, geology, and contamination at each site are contained in Part I, the Bioventing Pilot Test Work Plan.

1.0 SITE 16

1.1 Pilot Test Design and Construction

Installation of an air injection vent well (VW) and three vapor monitoring points (MPs) at Site 16 began on 7 January 1993, and was completed on 9 January 1993. Drilling services were provided by West Hazmat Drilling, of Anaheim, California. Well installation and soil sampling were directed by Mr. Jim Walters, the Engineering-Science, Inc. (ES) geologist, and Mr. Christopher Pluhar, the ES test engineer. The following sections describe the final design and installation of the bioventing system at this site.

One VW, three MPs (MPA, MPB, and MPC), and a blower unit were installed at Site 16. Figures 1.1 and 1.2, respectively, depict the location of and a hydrogeologic cross section for the VW and MPs completed at Site 16. A soil gas probe was installed in the proximity of an existing background monitoring well (16 MW-44) for use as a background MP because there were no areas of uncontaminated soil at the site accessible for drilling. Well 16 MW-44 is located approximately 1,200 feet west of Site 16.

1.1.1 Air Injection Vent Well

The air injection VW was installed following procedures described in the Air Force Center for Environmental Excellence (AFCEE) bioventing protocol document (Hinchee et al., 1992). Figure 1.3 shows construction details for the VW. The VW was installed sandy soils that contained hydrocarbon contamination at the

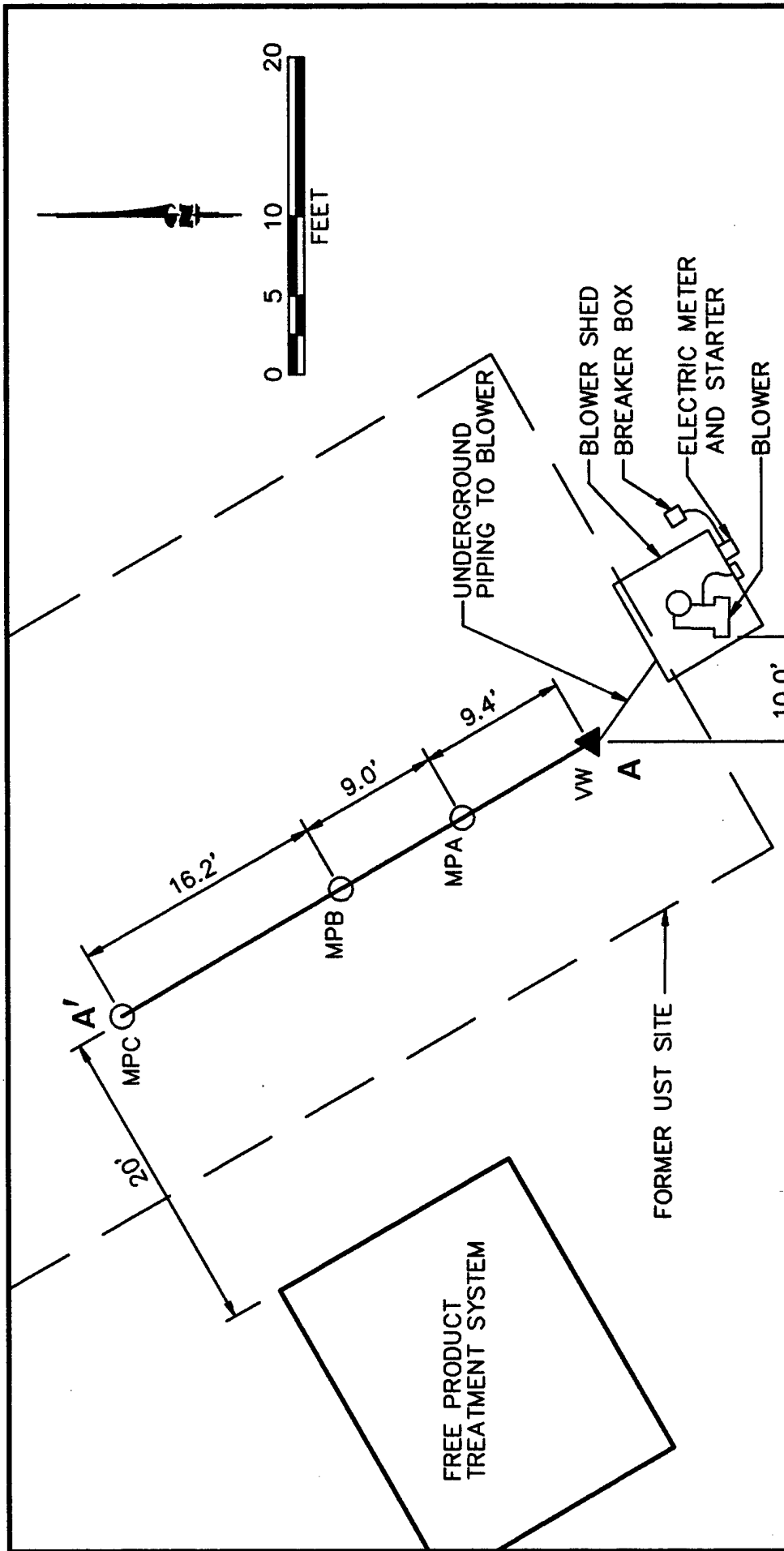

FIGURE 1.1
 SITE 16
 RECORD DRAWING
 VENT WELL MONITORING POINT
 LOCATIONS
 EDWARDS AFB, CALIFORNIA
 ENGINEERING-SCIENCE, INC.
 Denver, Colorado

LEGEND

- VW ▲ VENT WELL
- MPA ○ MONITORING POINT
- A — A' CROSS SECTION

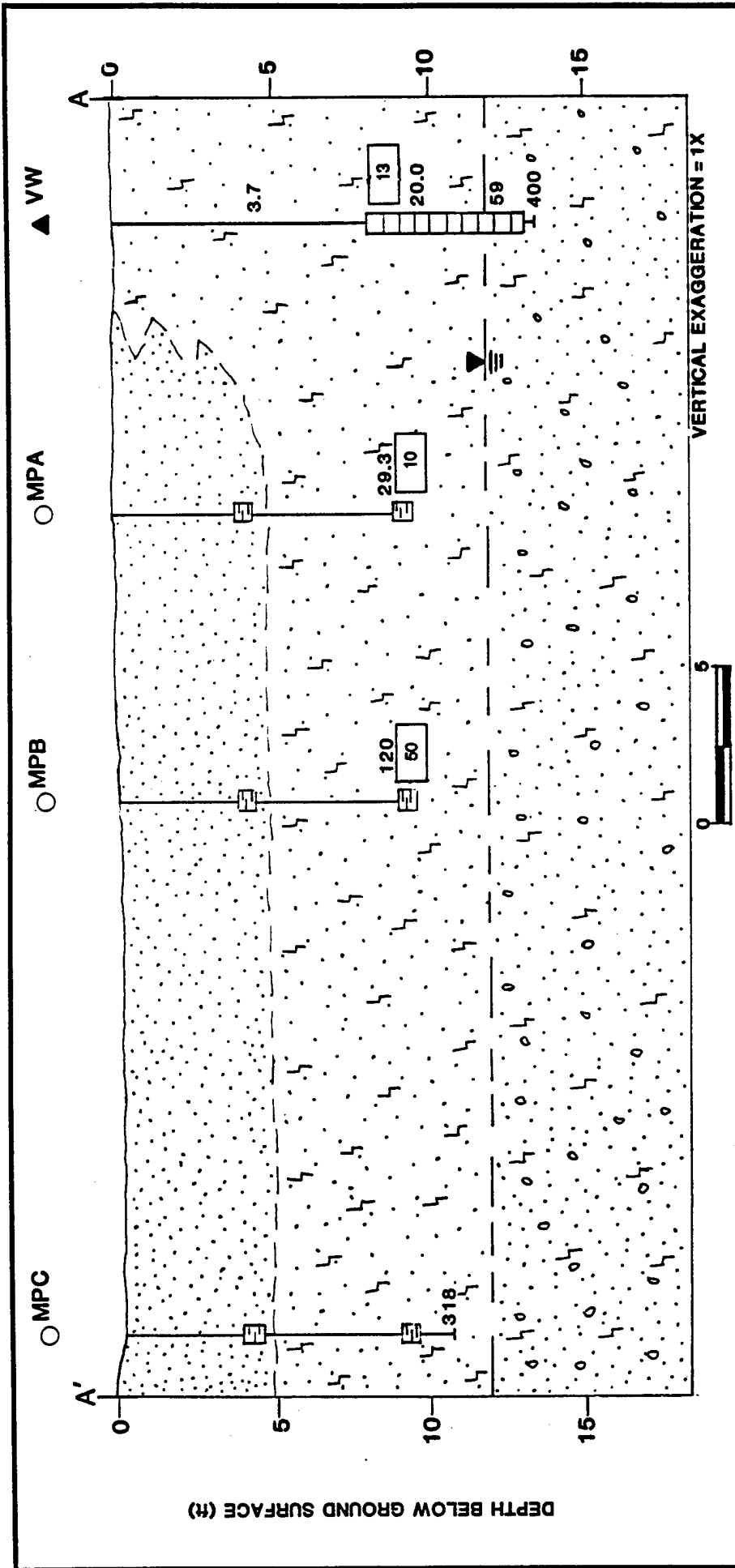
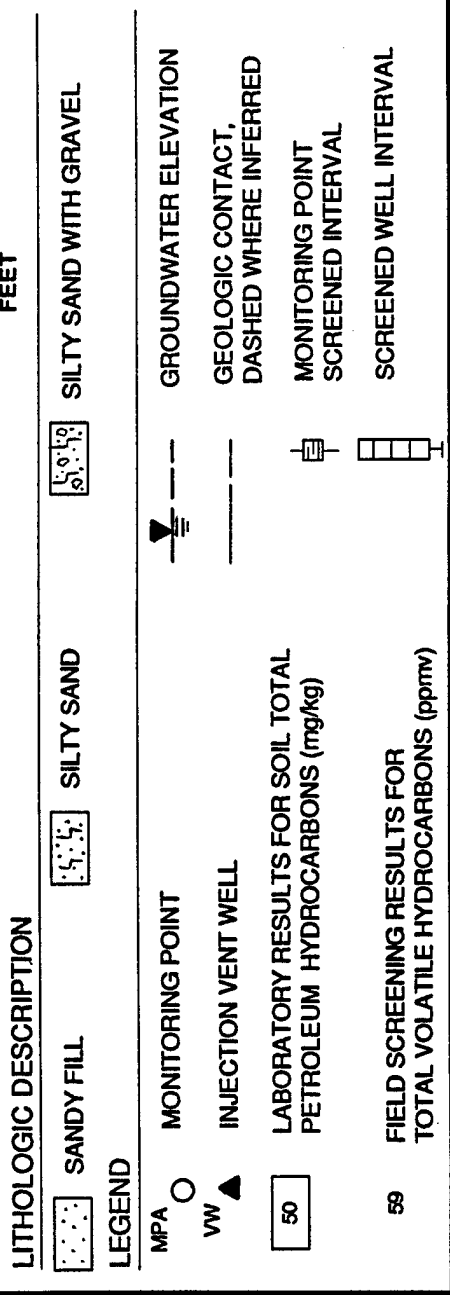
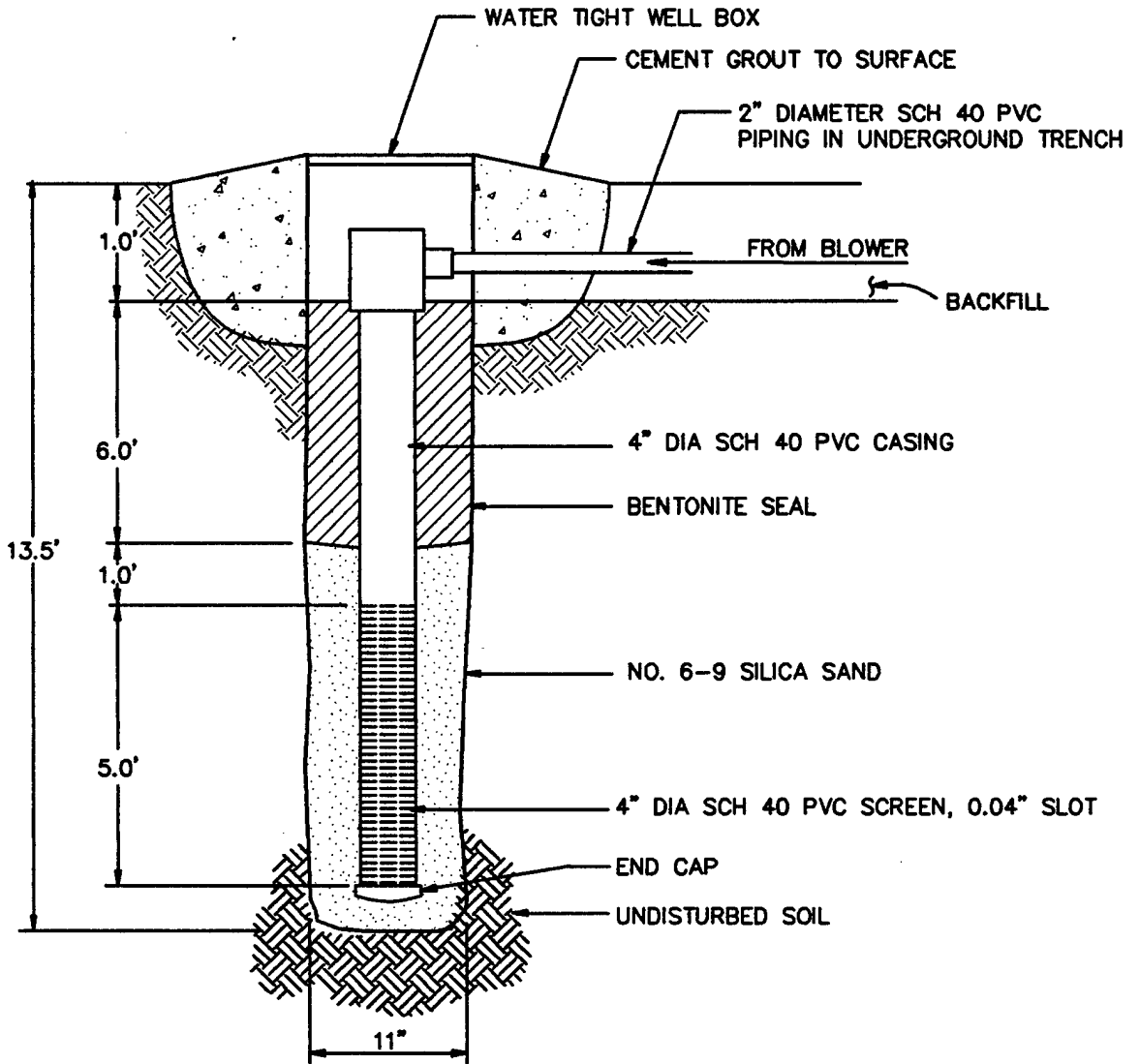

FIGURE 1.2
SITE 16
HYDROGEOLOGIC
CROSS SECTION
 EDWARDS AFB, CALIFORNIA
 ENGINEERING-SCIENCE, INC.
 Denver, Colorado **ES**





NOT TO SCALE

FIGURE 1.3
 SITE 16
 RECORD DRAWING
 AIR INJECTION VENT WELL
 CONSTRUCTION DETAIL
 EDWARDS AFB, CALIFORNIA
 ENGINEERING-SCIENCE, INC.
 Denver, Colorado



sampling location 8.5 feet below ground surface (bgs). Groundwater was encountered at 11.5 feet bgs. The VW was constructed using 4-inch-diameter, Schedule 40 polyvinyl chloride (PVC) casing, with 5 feet of 0.04-inch slotted PVC screen installed from 8 to 13 feet bgs. The annular space between the well casing and borehole was filled with 6-9 silica sand from the bottom of the borehole to approximately 1 foot above the well screen. Approximately 6 feet of granular bentonite was placed above the sand in 6-inch lifts, with each lift being hydrated in place. On top of the bentonite layer, approximately 1 foot of concrete was placed and finished flush with the existing surface. The well casing was finished with a T-fitting approximately 6 inches bgs. The fitting is attached to a 2-inch-diameter, Schedule 40 PVC pipe which runs underground for approximately 10 feet to the blower. The PVC pipe is connected to a galvanized steel riser pipe, which is connected to the blower with a galvanized steel union.

1.1.2 Monitoring Points

At Site 16, the MP screens were installed at 4- and 9-foot depths. The three MPs (MPA, MPB, and MPC) were constructed as shown in Figures 1.2 and 1.4. Each MP monitoring interval was constructed using a 6-inch section of 1-inch-diameter PVC well screen and a 0.25-inch-diameter Schedule 80 PVC riser pipe extending to the ground surface. At the top of each riser, a ball valve and a 3/16-inch hose barb were installed. The top of each MP was completed with a flush-mounted metal well protector set in a concrete base. Thermocouples were installed at the 4- and 9-foot depths at MPA to measure soil temperature variations.

1.1.3 Blower Unit

During the initial pilot test, a portable 3-horsepower Roots® 22U-RAI positive-displacement blower unit was used. A 2.5-horsepower Gast® R5125-2 regenerative blower unit was installed at Site 16 and connected to the air injection VW for the extended pilot test. The fixed unit is energized by 208-volt, single-phase, 30-amp line power from an existing trailer hookup on site. The configuration, instrumentation, and specifications for this blower system are shown on Figure 1.5. The blower is currently transporting air at a flow rate of approximately 50 cubic feet per minute (cfm) for the extended pilot test. After blower installation and startup, ES engineers provided an operation and maintenance (O&M) manual, including maintenance instructions, equipment specifications, and monitoring forms to base personnel. A copy of the O&M manual is provided in Appendix A.

1.2 SOIL AND SOIL GAS SAMPLING RESULTS

1.2.1 Soil Sampling Results

Soils at this site primarily consist of sand and silty sand. Groundwater was encountered at a depth of approximately 11.5 feet bgs in the VW. Although there is a free product recovery system in the vicinity of Site 16, no free product was found in borings installed on this site. More detailed hydrogeologic information regarding Site 16 can be found in the hydrogeologic cross section (Figure 1.2) and the geologic boring logs (Appendix B).

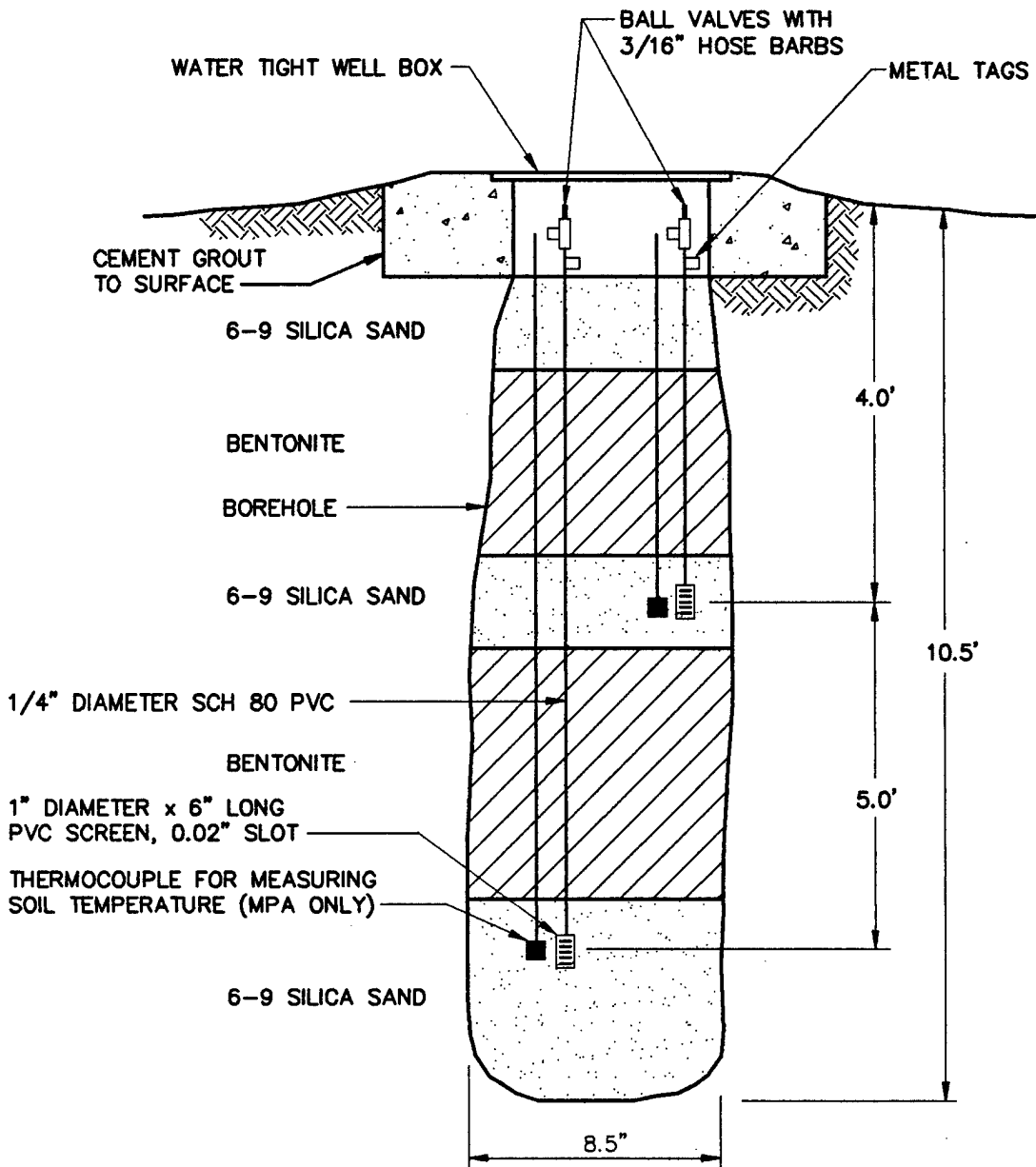

FIGURE 1.4
 SITE 16
 RECORD DRAWING
 MONITORING POINT
 CONSTRUCTION DETAIL
 EDWARDS AFB, CALIFORNIA
 ENGINEERING-SCIENCE, INC.
 Denver, Colorado



LEGEND

- ① INLET AIR FILTER - SOLBERG® AJ134E
- ② VACUUM GAUGE (0-60 in H₂O)
- ③ BLOWER - GAST® 2.5HP R5125-2
- ④ MANUAL PRESSURE RELIEF (BLEED) VALVE - 1 1/2" GATE
- ⑤ PRESSURE GAUGE (0-100 in H₂O)
- ⑥ TEMPERATURE GAUGE (0-250 °F)
- ⑦ AUTOMATIC PRESSURE RELIEF VALVE, SET TO RELEASE AT 52 IN H₂O PRESSURE
- ⑧ STARTER - FURNAS® 14CSE32DA NEMA 3, WITH START/STOP, OVERLOAD SET AT 12 AMPS
- ⑨ BREAKER BOX - 30 AMP

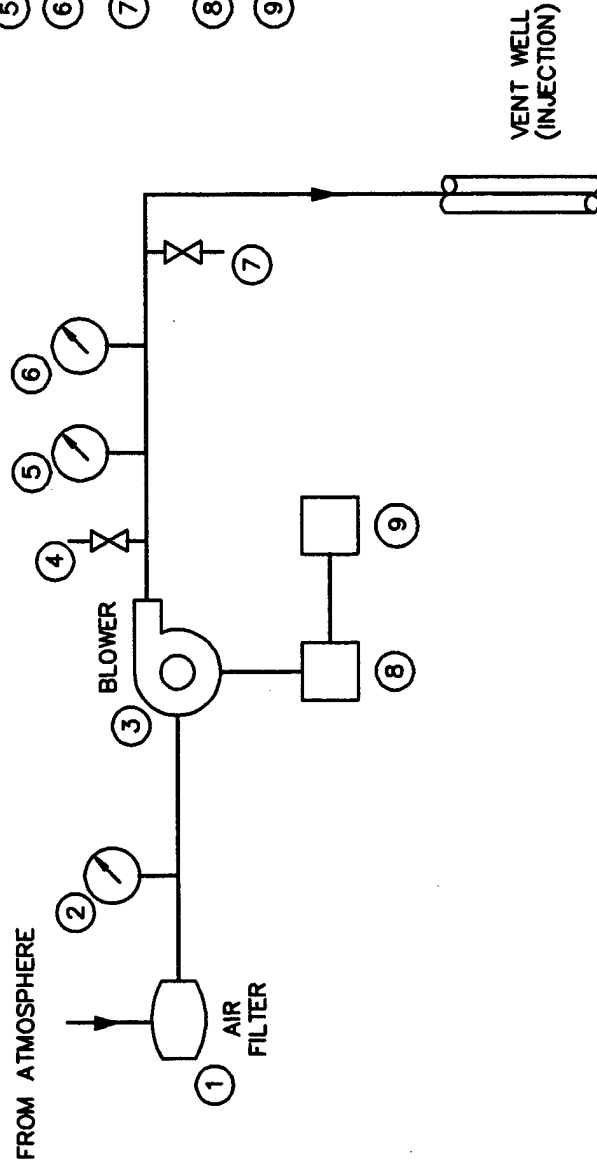

FIGURE 1.5

SITE 16
 RECORD DRAWING
 BLOWER SYSTEM
 FOR AIR INJECTION

EDWARDS AFB, CALIFORNIA
 ENGINEERING-SCIENCE, INC.
 Denver, Colorado



Contaminated soils were identified based on visual appearance, odor, and results of total hydrocarbon analyzer field screening for volatile organic compounds (VOCs). Based on appearance and odor, contaminated soils were encountered approximately 5 feet bgs in the VW and all MP boreholes and generally increased with depth.

Soil samples for laboratory analysis were collected from 18-inch split-spoon samplers with 2-inch-diameter brass liners. Soil samples were screened for VOCs using a hydrocarbon analyzer to determine the presence of contamination and to select soil samples for laboratory analysis. Soil samples for laboratory analysis were collected from MPA and MPB at a depth of 9.5 feet bgs, and from the VW at a depth of 8.5 feet bgs.

Soil samples were shipped via Federal Express® to the ES Berkeley laboratory for chemical and physical analysis. Soil samples were analyzed for total recoverable petroleum hydrocarbons (TRPH); benzene, toluene, ethylbenzene and xylenes (BTEX); iron; alkalinity; total Kjeldahl nitrogen (TKN); and several physical parameters. The results of these analyses are provided in Table 1.1. Chain-of-custody forms are provided in Appendix B.

1.2.2 Soil Gas Sampling Results

Soil gas samples were collected from the completed VW and at 9 feet bgs from MPA and MPC. Soil gas samples were collected using 3-liter Tedlar® bags and vacuum chambers. After the samples were collected in Tedlar® bags, they were transferred to 1-liter SUMMA® canisters and shipped to the laboratory.

Soil gas samples were shipped via Federal Express® to Air Toxics, Inc. in Rancho Cordova, California for total volatile hydrocarbon (TVH) and BTEX analysis. The TVH analyses were referenced to JP-4 jet fuel. The results of these analyses are provided in Table 1.1. Chain-of-custody forms are provided in Appendix B.

1.3 PILOT TEST RESULTS

1.3.1 Exceptions to Test Protocol Procedures

Procedures described in the protocol document (Hinchee et al., 1992) and the site-specific work plan (Part I) were used to complete the pilot test at Site 16. An area respiration test, rather than tests at individual MPs, was performed at this site because oxygen was adequately supplied to all MPs by the blower used for the air permeability test. Because individual blowers were not used, helium was not used at Site 16.

One exception to the work plan (Part I) was a change in proposed locations of the VW and MPC. These two well locations were reversed due to greater apparent contamination in the planned location of MPC than that of the VW.

1.3.2 Initial Soil Gas Chemistry

Prior to initiating air injection, all MPs and the VW were purged, and initial oxygen, carbon dioxide, and TVH concentrations were sampled using portable gas analyzers, as described in the technical protocol document (Hinchee et al., 1992).

TABLE 1.1
SOIL AND SOIL GAS LABORATORY ANALYTICAL RESULTS
SITE 16 BUILDING 1820 UST EXCAVATION AREA
EDWARDS AFB, CALIFORNIA

Analyte (Units) ^{a/}	Sample Location-Depth (feet below ground surface)		
<u>Soil Gas Hydrocarbons</u>	<u>VW</u>	<u>MPA-9</u>	<u>MPC-9</u>
TVH (ppmv)	39,000	70,000	80,000
Benzene (ppmv)	150	260	280
Toluene (ppmv)	28	32	19
Ethylbenzene (ppmv)	17	26	17
Xylenes (ppmv)	84	140	42
<u>Soil Hydrocarbons</u>	<u>VW-8.5</u>	<u>MPA-9.5</u>	<u>MPB-9.5</u>
TRPH (mg/kg)	13	10	50
Benzene (mg/kg)	ND ^{b/}	ND	ND
Toluene (mg/kg)	0.053	6.1	0.760
Ethylbenzene (mg/kg)	0.036	ND	ND
Xylenes (mg/kg)	0.260	32	4.1
<u>Soil Inorganics</u>	<u>VW-8.5</u>	<u>MPA-9.5</u>	<u>MPB-9.5</u>
Iron (mg/kg)	12,700	11,300	13,500
Alkalinity (mg/kg as CaCO ₃)	730	1,100	87
pH (units)	9.2	9.9	9.6
TKN (mg/kg)	46	ND	ND
Phosphates (mg/kg)	700	630	560
<u>Soil Physical Parameters</u>	<u>VW-8.5</u>	<u>MPA-9.5</u>	<u>MPB-9.5</u>
Moisture (% wt.)	12.3	21.3	7.6
Gravel (%)	3	1	1
Sand (%)	62	75	72
Silt (%)	24	19	17
Clay (%)	11	5	10

a/ TRPH = total recoverable petroleum hydrocarbons; TVH = total volatile hydrocarbons; mg/kg = milligrams per kilogram, ppmv = parts per million, volume per volume; CaCO₃ = calcium carbonate; TKN = total Kjeldahl nitrogen.

b/ ND = not detected.

Table 1.2 summarizes the initial soil gas chemistry at Site 16. The shallow depth of MPB was found to contain water during initial soil gas sampling. This appears to be residual water from bentonite hydration during well construction. The 9-foot depth of MPB did not appear to be affected. The results strongly indicate that biological fuel degradation has depleted the oxygen supply in the vadose zone soils. Three MPs and the VW at Site 16 contained oxygen levels lower than 8 percent. In contrast, the background MP, installed in uncontaminated soil approximately 1,200 feet west of Site 16, contained 21 percent oxygen. Carbon dioxide was present at elevated concentrations, ranging from 5.7 to 8.3 percent, in all initial soil gas samples collected at the 9-foot depths at Site 16. The background MP carbon dioxide level was 0.05 percent.

1.3.3 Air Permeability

An air permeability test was conducted at Site 16 according to protocol document procedures. Air was injected into the VW for approximately 19 hours at a rate of approximately 11 actual cfm (acfm) and an average pressure of approximately 7 pounds per square inch (psi). The pressure responses at each MP are listed in Table 1.3. The pressure measured at all MPs continued to increase for the duration of the test. The dynamic method of determining air permeability that is coded in the HyperVentilate® model was used to calculate soil gas permeability values ranging from 10 darcys to 143 darcys for this site. A radius of pressure influence of 35 feet was observed at all depths.

1.3.4 Oxygen Influence

The depth and radius of oxygen influence in the subsurface resulting from air injection into the central VW during pilot testing is the primary design parameter for full-scale bioventing systems. Optimization of full-scale and multiple VW systems requires pilot testing to determine the volume of soil that can be oxygenated at a given flow rate and VW screen configuration.

Table 1.4 describes the change in soil gas oxygen levels that occurred after the initial 3-hours of air injection during the air permeability test at the site. This relatively brief air injection period at 11 acfm produced changes in soil gas oxygen levels at a distance of at least 35 feet from the central VW at the 9-foot depth MPs. Oxygen level increases at the 4-foot depth MPs were insignificant (Table 1.4). This was attributed to the fact that contamination occurred at the 8- to 11-foot depths and oxygen was not depleted at the 4-foot depth. This was likely due to loosely packed soil and lack of contamination. Based on measured pressure response, which is an indicator of long-term oxygen transport, it is anticipated that the radius of influence for a long-term bioventing system at this site will exceed 35 feet at all depths. Monitoring during the extended pilot test at this site will better define the effective treatment radius.

1.3.5 In Situ Respiration Rates

In situ respiration testing was performed at Site 16 using the area respiration test method. Air was injected into the VW for 16 hours, which raised the oxygen concentration in all the MPs to at least 18 percent (with the exception of MPB-4

TABLE 1.2
INITIAL SOIL GAS CHEMISTRY
SITE 16 BUILDING 1820 UST EXCAVATION AREA
EDWARDS AFB, CALIFORNIA

Sample Location	Depth (ft)	O ₂ (%)	CO ₂ (%)	TVH (ppmv) ^{a/}	TRPH (mg/kg) ^{b/}	Temperature °F
MPA	4	20.5	0.3	1,000	NS ^{c/}	52.5
MPB	4	- ^{d/}	-	-	NS	-
MPC	4	18.3	1.0	360	NS	NS
MPA	9	0.2	8.2	1,000	10	62.5
MPB	9	0.5	8.1	180	50	NS
MPC	9	0.0	8.3	840	NS	NS
VW	8-11.5	7.2	5.7	16,000	13	NS
Background	4	21.0	0.05	NS	NS	NS

- a/ Total hydrocarbon analyzer field screening results.
b/ Laboratory results.
c/ NS=not sampled.
d/ Not sampled; point contains water.

TABLE 1.3
PRESSURE RESPONSE (inches of water) DURING THE
AIR PERMEABILITY TEST
SITE 16 BUILDING 1820 UST EXCAVATION AREA
EDWARDS AFB, CALIFORNIA

Depth (feet)	MPA		MPB		MPC	
	4	9	4	9	4	9
Elapsed Time (min)						
1	0.65	3.0	0	1.0	0.08	0.60
2	0.80	3.70	0.4	1.6	0.03	>1.0
3	0.83	4.15	0.6	2.0	0.03	.a/
4	0.85	4.41	0.6	2.1	0.04	1.4
5	0.90	4.81	0.7	2.3	0.08	1.6
6	0.90	5.02	1.0	2.5	0.10	1.7
7	0.90	5.30	1.1	2.6	0.10	1.8
8	0.91	5.45	1.1	2.8	0.10	1.8
9	0.92	5.62	1.2	2.8	0.11	1.9
10	0.95	5.80	1.3	3.0	0.11	2.0
12	0.98	6.10	1.5	3.2	0.12	2.1
14	1.0	6.3	1.6	3.3	0.12	2.2
16	1.0	6.5	1.7	3.4	0.12	2.25
18	1.0	6.8	1.9	3.5	0.12	2.4
20	1.0	6.9	1.8	3.6	0.12	2.4
23	1.0	7.2	1.8	3.8	0.12	2.5
26	1.01	7.5	1.9	4.0	0.13	2.6
29	1.01	7.8	2.1	4.1	0.13	2.7
32	1.03	7.9	2.2	4.3	0.14	2.8
35	1.04	8.18	2.1	4.4	0.14	2.8
38	1.05	8.3	2.1	4.5	0.14	2.8
42	1.05	8.4	2.1	4.6	0.14	2.9
46	1.05	8.6	2.2	4.7	0.14	3.0
50	1.06	8.62	2.25	4.7	0.14	3.0
55	1.08	8.7	2.3	4.8	0.14	3.0
60	1.09	8.9	2.35	4.9	0.14	3.1
68	1.10	9.05	2.4	5.0	0.14	3.1
76 ^{b/}	0.95	9.8	2.45	5.4 ^{c/}	0.14	3.35
84	0.95	9.3 ^{c/}	0.9 ^{c/}	6.2 ^{c/}	0.15	3.4
90	0.98	9.3	1.3	6.3	0.15	3.4
110	1.0	9.5	1.8	6.4	0.15	3.5
142	1.02	9.9 ^{d/}	1.95	6.6	0.15	3.5 ^{d/}
160	1.01	10.0	2.0	6.8	0.15	3.65
202	1.01 ^{d/}	10.5 ^{d/}	<0.0 ^{d/}	6.95 ^{d/}	0.14 ^{d/}	3.8 ^{d/}
1,128	0.95	13.9	0.1	8.4	0.13	4.7

- a/ -- indicates reading not taken at this time point.
- b/ Blower shut off for 30 seconds.
- c/ Changed gauges.
- d/ Respiratory readings initiated; pressure released.

TABLE 1.4
INFLUENCE OF AIR INJECTION AT VENT WELL
ON MONITORING POINT OXYGEN LEVELS
SITE 16 BUILDING 1820 UST EXCAVATION AREA
EDWARDS AFB, CALIFORNIA

MP	Distance From VW (ft)	Depth(ft)	Initial O ₂ (%)	Final O ₂ (%) ^{a/}
A	9.4	4	20.5	20.8
B	18.4	4	- ^{b/}	-
C	34.6	4	18.3	18.2
A	9.4	9	0.2	20.3
B	18.4	9	0.5	19.4
C	34.60	9	0.0	18.0

a/ Readings taken after initial 3 hours of air injection during air permeability test.
b/ Reading not taken; point contains water.

which contained water). At the end of the 16-hour period, air injection ceased, and changes in soil gas composition were monitored over time. Oxygen, TVH, and carbon dioxide were measured over a period of 125 hours following the air injection period. The observed rates of oxygen utilization were then used to estimate the aerobic fuel degradation rates at Site 16. Figures 1.6 through 1.9 present the results of *in situ* respiration testing at the site, and Table 1.5 provides a summary of the observed oxygen utilization rates.

At Site 16, an estimated 60 to 400 milligrams (mg) of fuel per kilogram (kg) of soil can be degraded each year. This value is the range of the fuel consumption rates calculated for the two outermost 9-foot MPs, at which the hydrocarbon concentrations were highest. The point-specific fuel consumption rates were calculated using observed oxygen utilization rates, an estimated air-filled porosity of 0.22, and a conservative ratio of 3.5 mg of oxygen consumed for every 1 mg of fuel biodegraded. Oxygen loss was consistent and linear at the two outermost sampling points. The oxygen utilization rates observed in contaminated soils ranged from 0.0003 percent per minute (%/min) to 0.002 %/min (Table 1.5) indicating that the highest levels of biological activity are located at the deeper, more contaminated levels of MPB and MPC.

1.3.6 Potential Air Emissions

Soil concentrations of BTEX compounds detected were less than 40 mg/kg, and soil gas concentrations were measured at 458 ppmv. The long-term potential for air emissions from full-scale bioventing operations at this site is moderate. Initial emissions should be minimal because accumulated vapors will move slowly outward from the air injection point and will be biodegraded as they move horizontally through the soil. During the air permeability test, air was injected at 11 acfm. Health and safety hydrocarbon-analyzer air monitoring of the breathing zone at the site indicated that total hydrocarbon concentrations had not increased above 1 part per million, volume per volume (ppmv) during the initial days of the test. The initial day of bioventing generally procedures the highest potential emissions as the first pore volume of soil gas is replaced.

1.4 RECOMMENDATIONS

Initial bioventing tests at this site indicate that oxygen had been depleted in the contaminated soils, and that air injection is an effective method of stimulating aerobic fuel biodegradation. AFCEE has recommended that air injection continue at this site to determine the long-term radius of oxygen influence and the effect of time, available nutrients, and changing temperatures on fuel biodegradation rates.

A 2.5-horsepower regenerative blower has been installed at the site for continuous air injection. In July 1993, ES will return to the site to sample and analyze the soil gas and conduct a repeat respiration test. In January 1994, a final respiration test will be conducted, and soil and soil gas samples will be collected from the site to determine the degree of remediation achieved during the first year of *in situ* treatment.

TABLE 1.5
OXYGEN UTILIZATION RATES
SITE 16 BUILDING 1820 UST EXCAVATION AREA
EDWARDS AFB, CALIFORNIA

MP	O ₂ Loss ^{a/} (%)	Test Duration (min)	O ₂ Utilization ^{a/} Rate (%/min)
VW	1.2	4,410	0.0003
MPA-9	1.8	7,330	0.0005
MPB-9	3.1	7,330	0.0003
MPC-9	14.1	8,900	0.002

a/ Values based on linear regression (Figures 1.6 through 1.9).

Figure 1.6
 Respiration Test
 Site 16: Vent Well
 Edwards AFB, CA

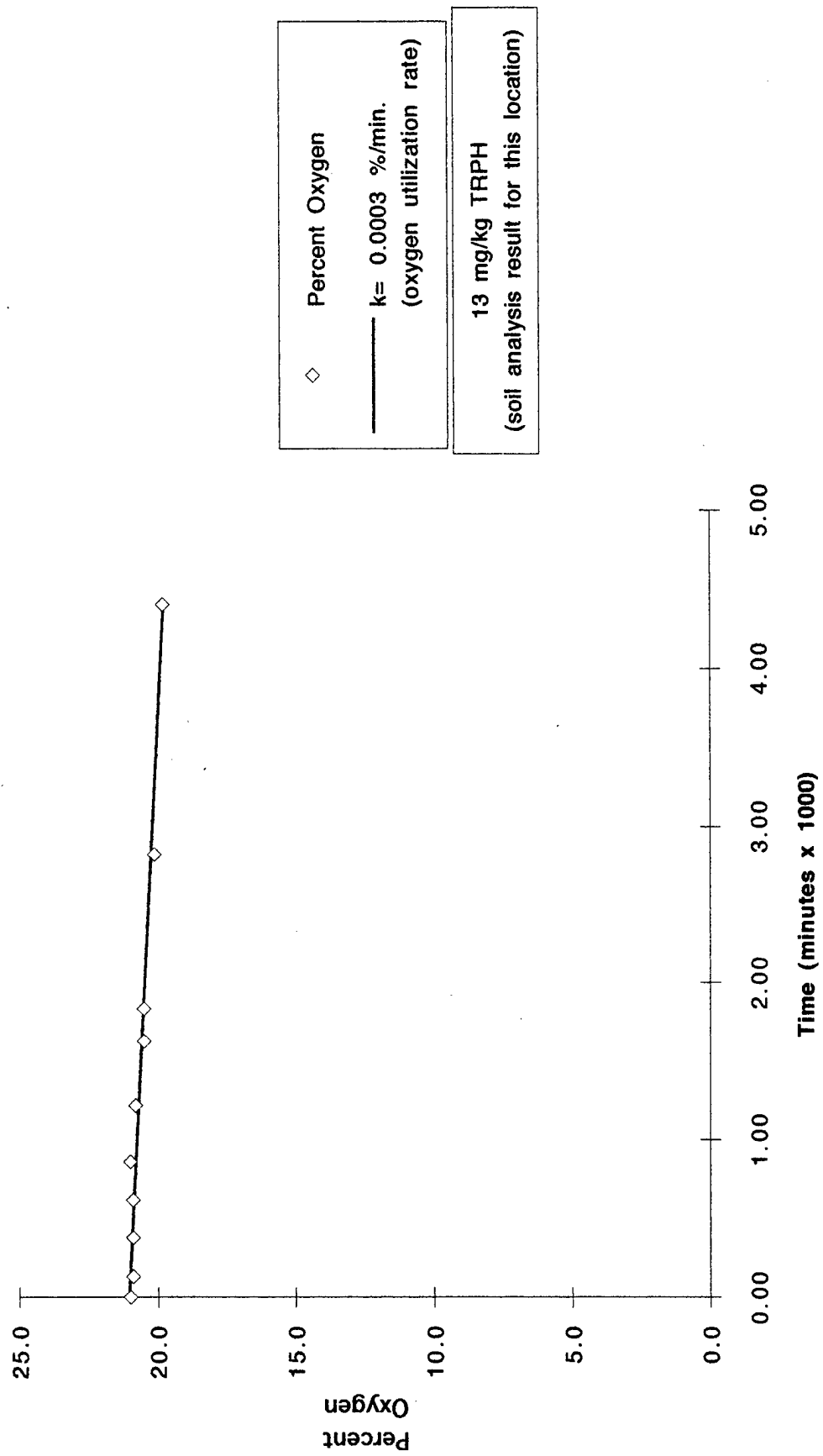

Figure 1.7
Respiration Test
Site 16: MPA-9
Edwards AFB, CA

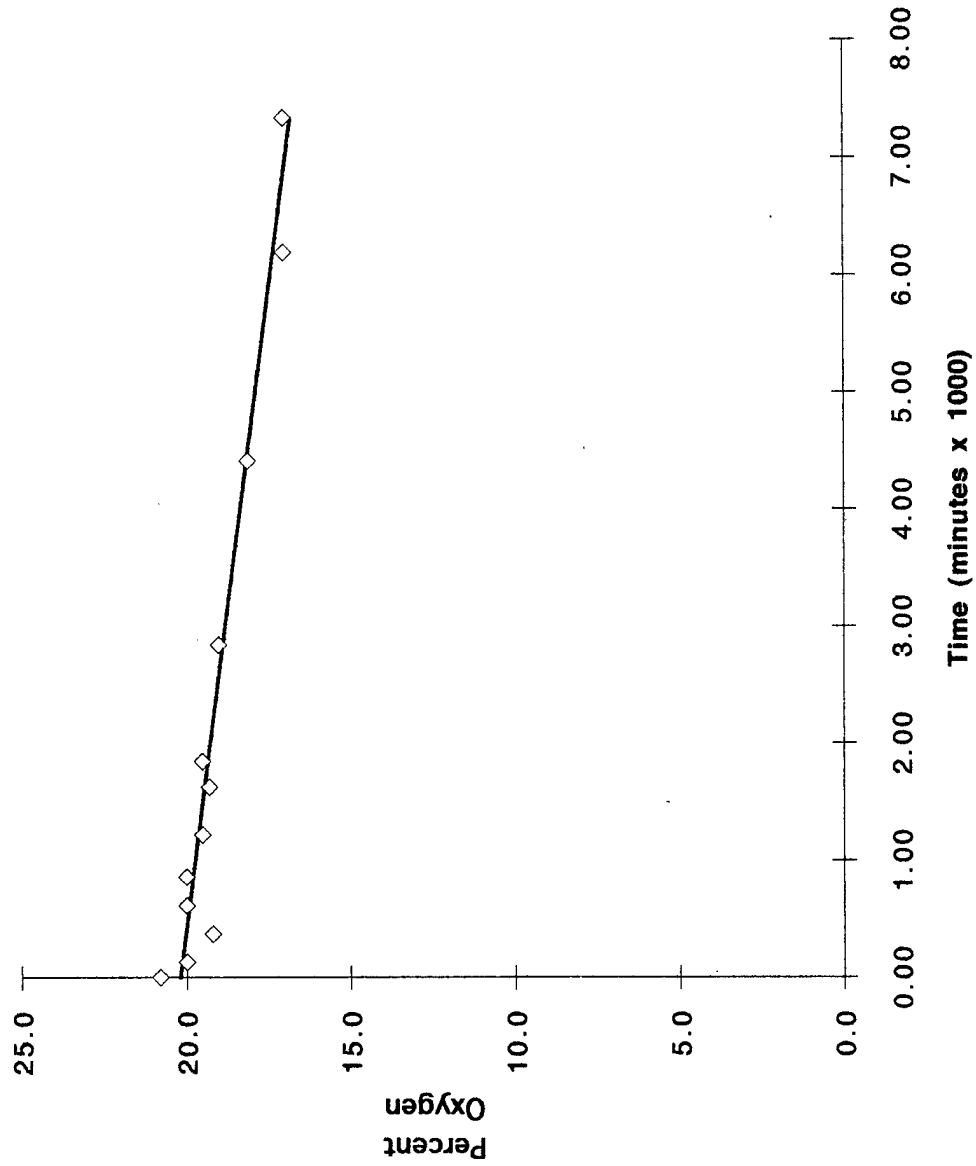
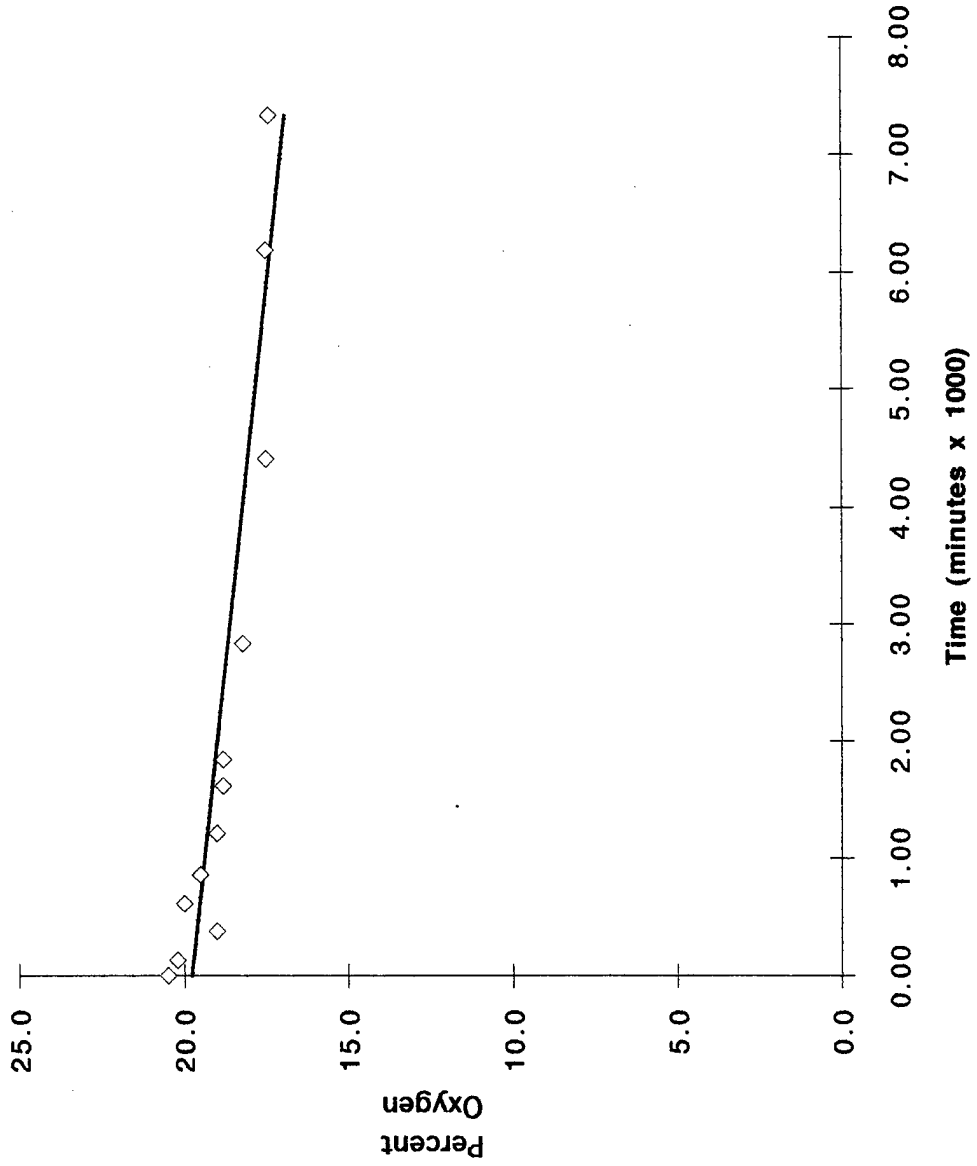
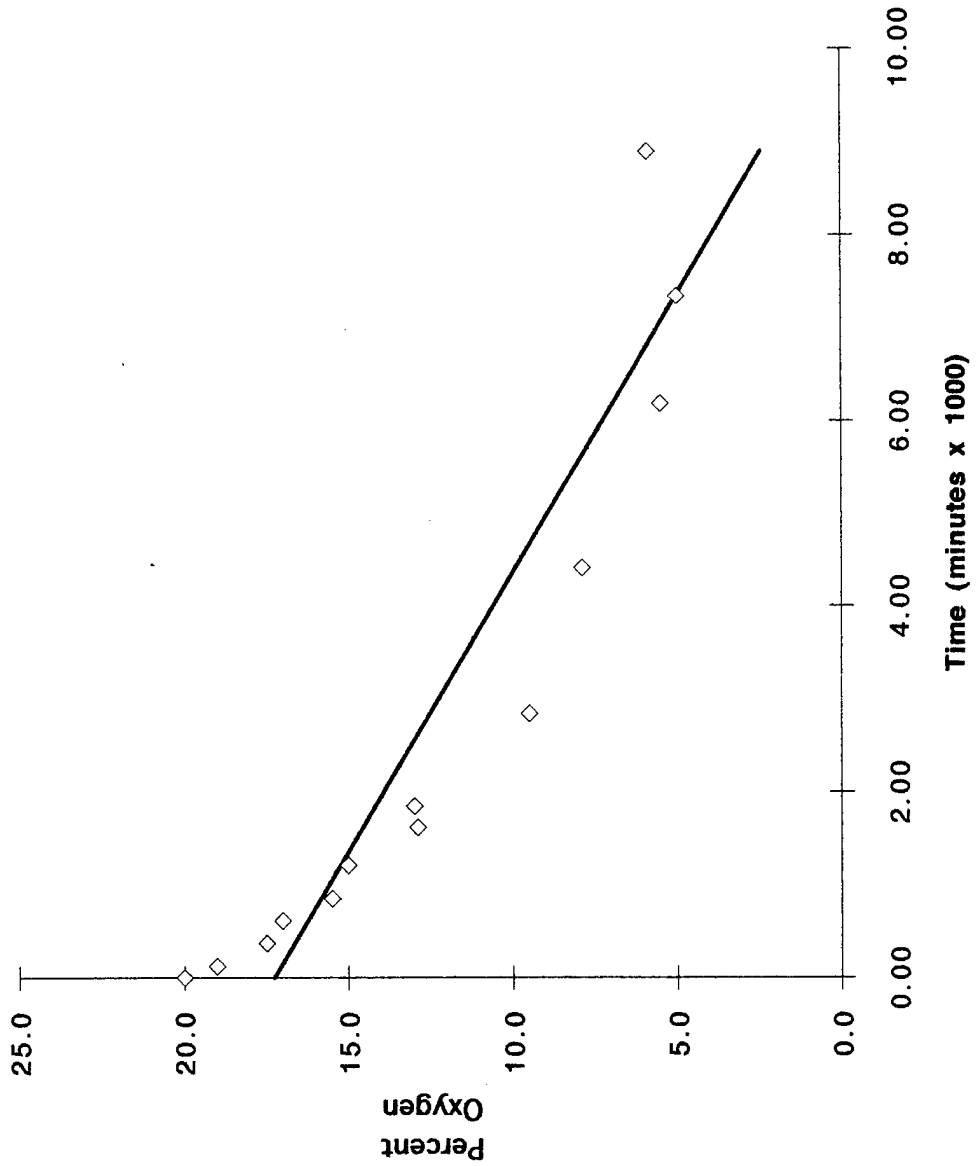

Figure 1.8
 Respiration Test
 Site 16: MPB-9
 Edwards AFB, CA



◇ Percent Oxygen
 — k= 0.0003 %/min.
 (oxygen utilization rate)
 50 mg/kg TRPH
 (soil analysis result for this location)

Figure 1.9
Respiration Test
Site 16: MPC-9
Edwards AFB, CA



Based on the results of the first year of pilot-scale bioventing, AFCEE will recommend one of three options:

1. Upgrade the pilot-scale system, if necessary, and continue operation of the bioventing system for full-scale remediation of the site. AFCEE can assist the base in obtaining regulatory approval for upgrading and continued operation.
2. If final soil sampling indicates significant contaminant removal has occurred, AFCEE may recommend additional sampling to confirm that cleanup criteria have been achieved.
3. If significant difficulties or poor results are encountered during bioventing at this site, AFCEE may recommend removal of the blower system and proper abandonment of the VW and MPs.

2.0 SITE 21

2.1 Pilot Test Design and Construction

Installation of an air injection VW and three MPs at Site 21 took place on 8 and 9 January, 1993. Drilling services were provided by West Hazmat Drilling of Anaheim, California. Well installation and soil sampling were directed by Mr. Jim Walters, the ES geologist, and Mr. Christopher Pluhar, the ES test engineer. The following sections describe the final design and installation of the bioventing system at this site.

One VW, three MPs (MP1, MP2, and MP3), and a blower unit were installed at Site 21. Figures 2.1 and 2.2, respectively, depict the locations of and hydrogeologic cross sections for the VW and MPs completed at Site 21. A soil gas probe was installed in the proximity of an existing background well (16 MW-44) for use as the background MP for this site because there were no areas of uncontaminated soil at this site accessible for drilling. Well 16 MW-44 is located approximately 2,500 feet west of Site 21.

2.1.1 Air Injection Vent Well

The air injection VW was installed following procedures described in the AFCEE bioventing protocol document (Hinchee et al., 1992). The VW was installed in sandy to silty-sand soils that contained hydrocarbon contamination at 11 feet bgs. Groundwater was encountered at a depth of 13.25 feet bgs. Figure 2.3 shows construction details for the VW. The VW was constructed using 4-inch-diameter, Schedule 40 PVC casing, with 7.5 feet of 0.04-inch slotted PVC screen installed from 7 to 14.5 feet bgs. The annular space between the well casing and borehole was filled with 6-9 silica sand from the bottom of the borehole to approximately 1 foot above the well screen. Approximately 5 feet of granular bentonite was placed above the sand in 6-inch lifts, with each lift being hydrated in place. On top of the bentonite layer, approximately 1 foot of concrete was placed and was finished flush with the ground surface. The well casing was cut off approximately 4 inches above the ground surface, and the casing was connected to a galvanized steel header using a PVC reducer.

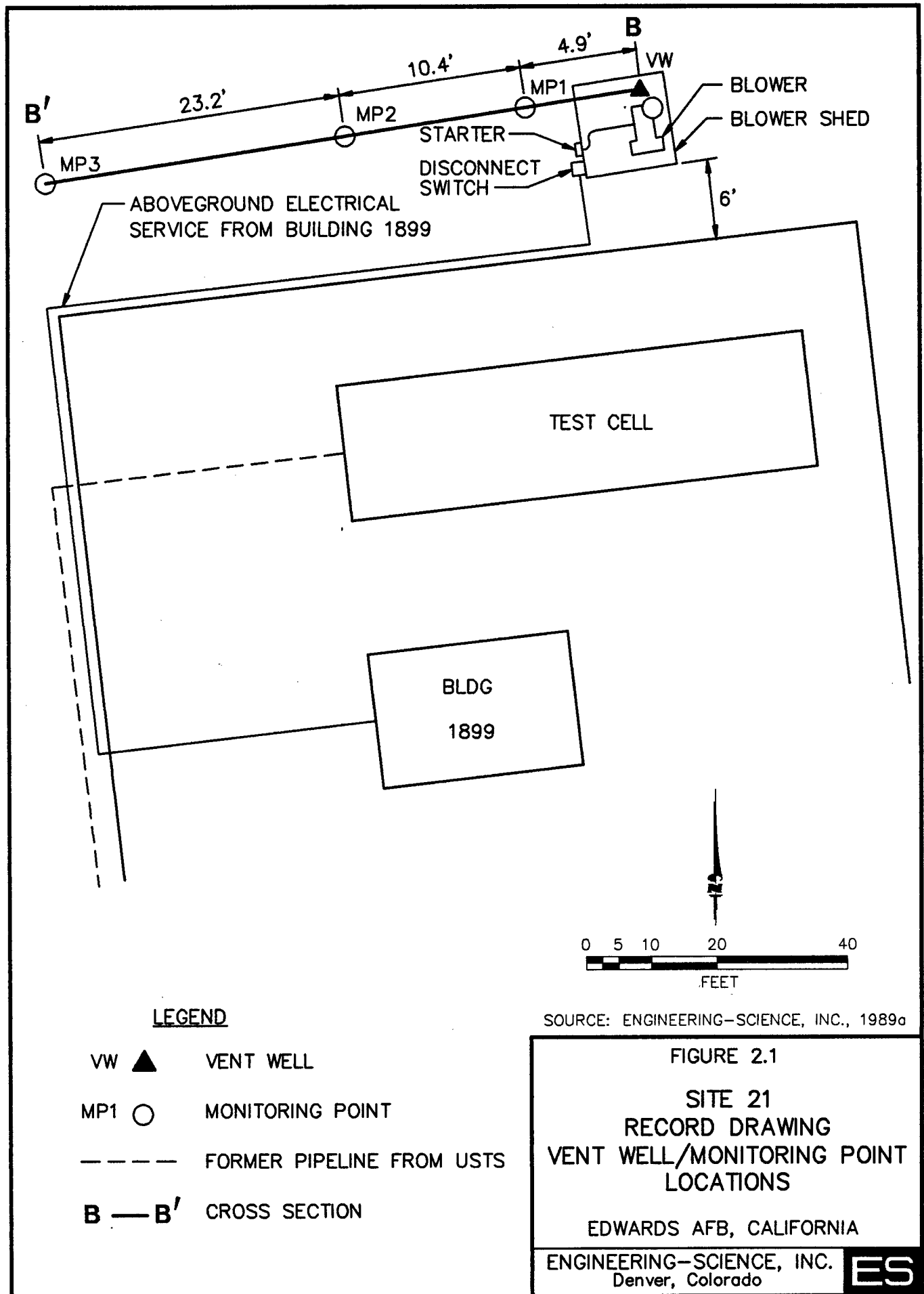

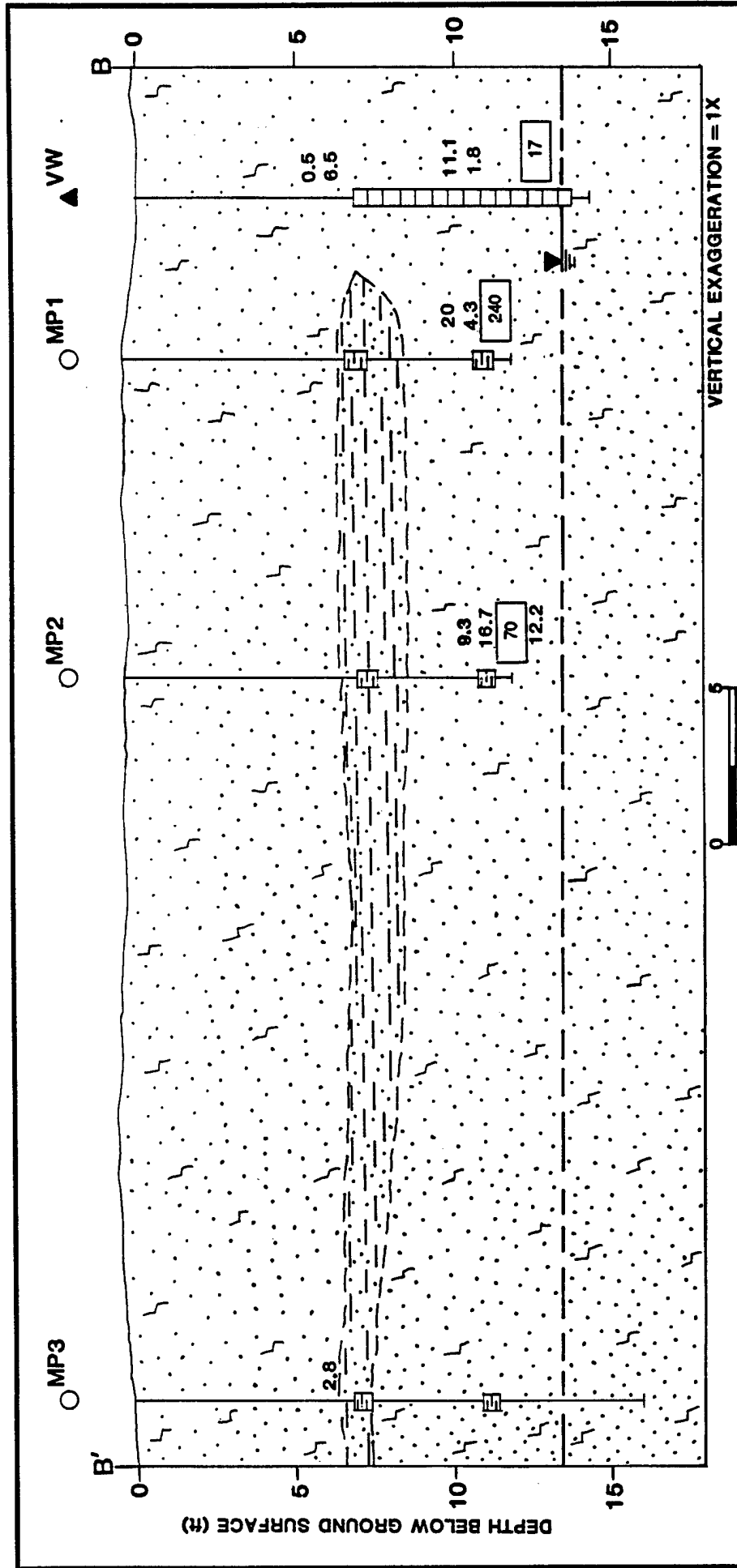

FIGURE 2.2

SITE 21

HYDROGEOLOGIC CROSS SECTION

EDWARDS AFB, CALIFORNIA

ENGINEERING-SCIENCE, INC.
Denver, Colorado

ES

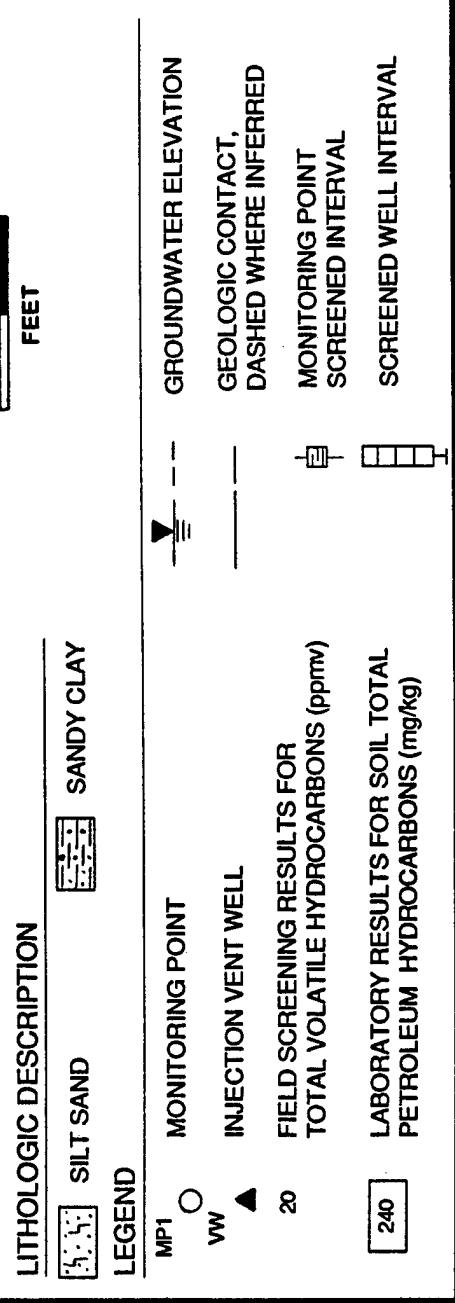

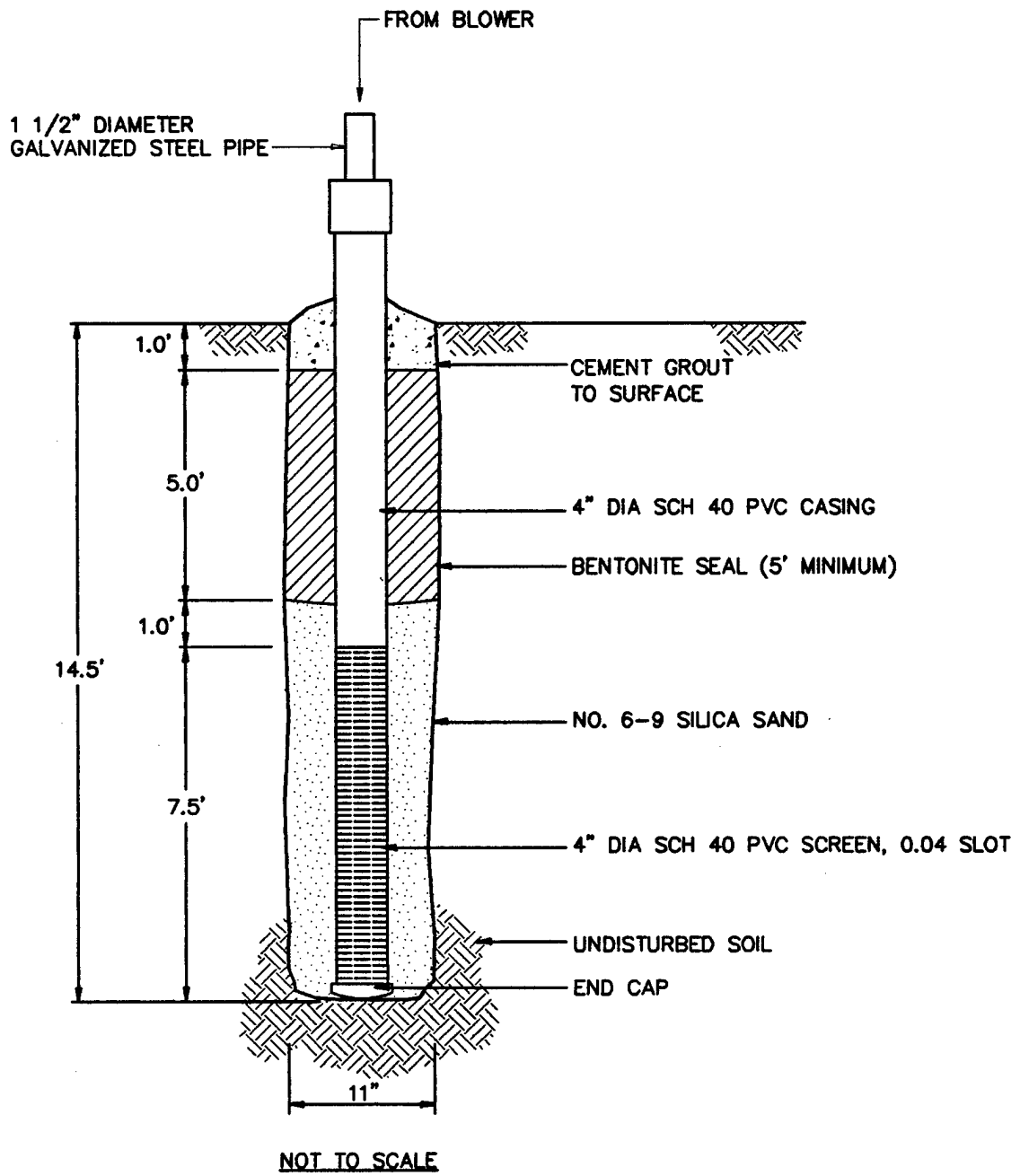

FIGURE 2.3

SITE 21

RECORD DRAWING

INJECTION VENTING WELL

CONSTRUCTION

EDWARDS AFB, CALIFORNIA

ENGINEERING-SCIENCE, INC.
Denver, Colorado

ES

2.1.2 Monitoring Points

The MP screens were installed at 7- and 11-foot depths. The three MPs (MP1, MP2, and MP3) at Site 21 were constructed as shown in Figures 2.2 and 2.4. Each MP interval was constructed using a 6-inch section of 1-inch-diameter PVC well screen and a 0.25-inch-diameter PVC riser pipe extending to the ground surface. At the top of each riser, a ball valve and a 3/16-inch hose barb were installed. The top of each MP was completed with a flush-mounted metal well protector set in a concrete base. Thermocouples were installed at the 7- and 11-foot depths at MP1 to measure soil temperature variations.

2.1.3 Blower Unit

During the initial pilot test, a 1.5-horsepower Gast® 2567-P102 rotary-vane blower unit was used. This unit was then installed at Site 21 and connected to the air injection VW for the extended pilot test. The fixed unit is energized by 240-volt, single-phase, 15-amp line power from a newly installed aboveground power line and breaker. The configuration and instrumentation for this system are shown on Figure 2.5. The blower is currently transporting air at a flow rate of approximately 4 cfm for the extended pilot test. After blower installation and startup, ES engineers provided an O&M manual, including maintenance instructions, equipment specifications and monitoring forms, to base personnel. A copy of the O&M manual is provided in Appendix A.

2.2 SOIL AND SOIL GAS SAMPLING RESULTS

2.2.1 Soil Sampling Results

Soils at this site are primarily sandy with some silty sand. Groundwater was encountered at a depth of approximately 13.25 feet bgs in the VW. The groundwater level appears to have risen during the course of the test since MP3-11 was found to be submerged during sampling. No free product was encountered in the VW. More detailed hydrogeologic information regarding Site 21 can be found in the hydrogeologic cross section (Figure 2.2) and the geologic boring logs (Appendix B).

Contaminated soils were identified based on visual appearance, odor, and VOC field screening results. Contaminated soils were encountered between 9 and 14 feet bgs in the VW between 9 and 12 feet in and each MP. Soils at these locations had a hydrocarbon odor.

Soil samples for laboratory analysis were collected from 18-inch split-spoon samplers with 2-inch-diameter brass liners. Soil samples were screened for VOCs using a photoionization detector (PID) to determine the presence of contamination and to select soil samples for laboratory analysis. Soil samples for laboratory analysis were collected from MP1, MP2, and the VW at a depth of 11.5 feet bgs.

Soil samples were shipped via Federal Express® to the ES Berkeley laboratory for chemical and physical analysis. Soil samples were analyzed for TRPH, BTEX, iron, alkalinity, TKN, and several physical parameters. The results of these analyses are provided in Table 2.1. Chain-of-custody forms are provided in Appendix B.

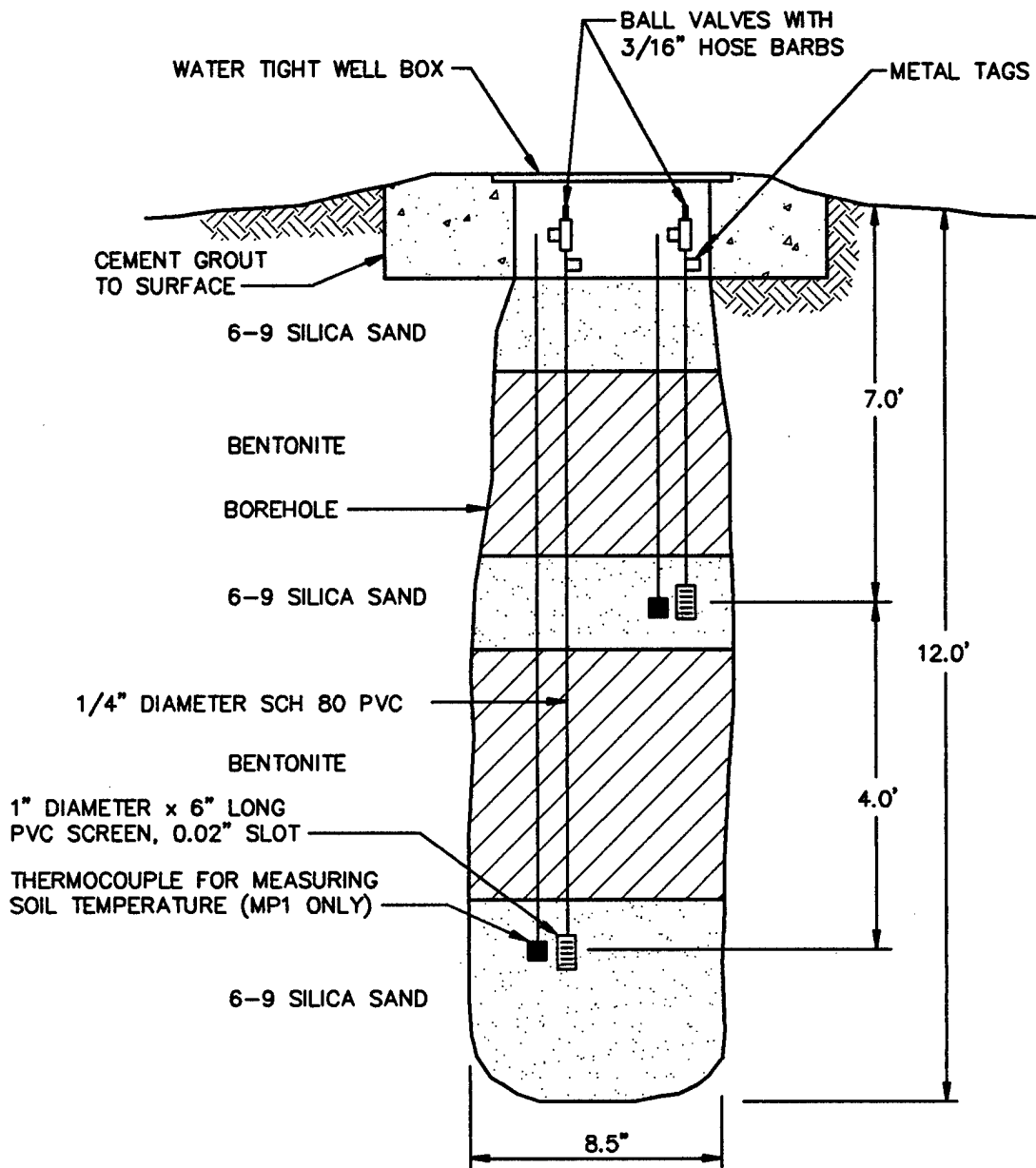

FIGURE 2.4
 SITE 21
 RECORD DRAWING
 MONITORING POINT
 CONSTRUCTION DETAIL

EDWARDS AFB, CALIFORNIA

ENGINEERING-SCIENCE, INC.
 Denver, Colorado



LEGEND

- ① INLET AIR FILTER - GAST® D344B
- ② BLOWER - GAST® ROTARY VANE 2567-P102A WITH A 1.5 HP MOTOR #VL5024A
- ③ MANUAL PRESSURE RELIEF (BLEED) VALVE - 3/4" GATE
- ④ TEMPERATURE GAUGE (0-250 °F)
- ⑤ PRESSURE GAUGE (0-100 in H₂O)
- ⑥ STARTER - FURNAS® 14CSD33DA NEMA 3, NO START/STOP, OVERLOAD SET AT 8AMPS
- ⑦ DISCONNECT SWITCH - 240V/SINGLE PHASE/15 AMP, FUSED DISCONNECT (GENERAL DUTY)
- ⑧ BREAKER BOX INSIDE BUILDING 1899

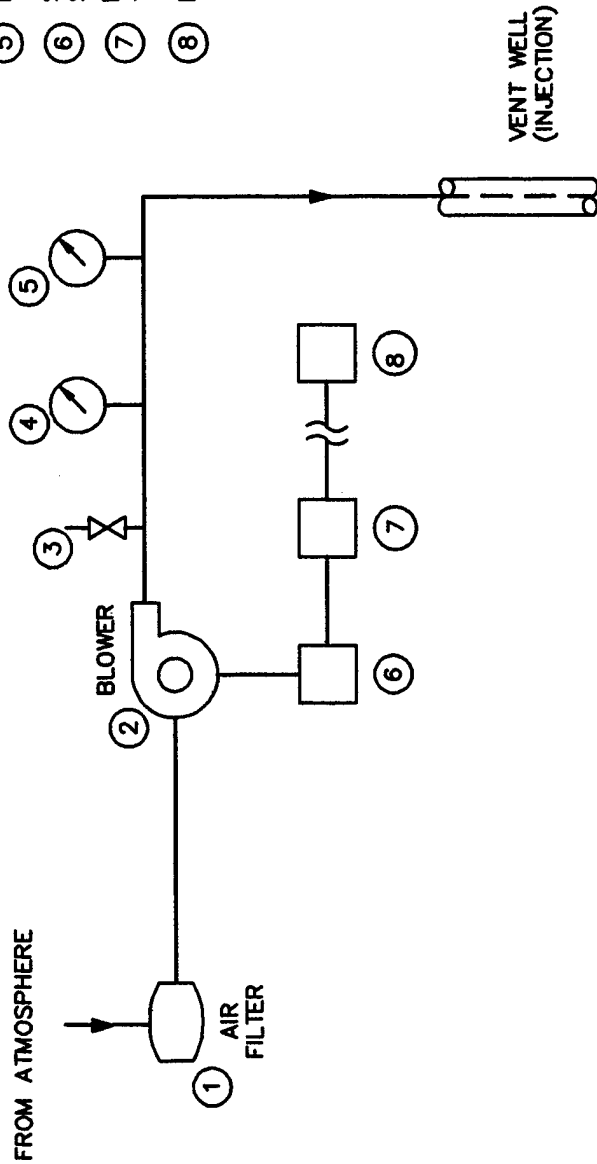

FIGURE 2.5

SITE 21

**RECORD DRAWING
BLOWER SYSTEM
FOR AIR INJECTION**

EDWARDS AFB, CALIFORNIA

ENGINEERING-SCIENCE, INC.
Denver, Colorado

TABLE 2.1
SOIL AND SOIL GAS LABORATORY ANALYTICAL RESULTS
SITE 21 JET ENGINE TEST AREA
EDWARDS AFB, CALIFORNIA

Analyte (Units) ^{a/}	Sample Location-Depth (feet below ground surface)			
	<u>VW</u>	<u>VW Duplicate</u>	<u>MP1-11</u>	<u>MP2-11</u>
<u>Soil Gas Hydrocarbons</u>				
TVH (ppmv)	32,000	37,000	67,000	48,000
Benzene (ppmv)	110	120	300	150
Toluene (ppmv)	24	28	ND ^{b/}	22
Ethylbenzene (ppmv)	9.9	12	15	12
Xylenes (ppmv)	30	36	45	38
<u>Soil Hydrocarbons</u>	<u>VW-11.5</u>	<u>MP1-11.5</u>	<u>MP2-11.5</u>	
TRPH (mg/kg)	17	240	70	
Benzene (mg/kg)	ND	ND	ND	
Toluene (mg/kg)	1.5	3.2	ND	
Ethylbenzene (mg/kg)	ND	ND	0.0008	
Xylenes (mg/kg)	6.5	13	ND	
<u>Soil Inorganics</u>	<u>VW-11.5</u>	<u>MP1-11.5</u>	<u>MP2-11.5</u>	
Iron (mg/kg)	10,500	10,900	8,490	
Alkalinity (mg/kg as CaCO ₃)	890	850	460	
pH (units)	9.2	9.1	9.6	
TKN (mg/kg)	44	ND	24	
Phosphates (mg/kg)	630	630	700	
<u>Soil Physical Parameters</u>	<u>VW-11.5</u>	<u>MP1-11.5</u>	<u>MP2-11.5</u>	
Moisture (% wt.)	8.4	15.0	9.8	
Gravel (%)	0	0	0	
Sand (%)	73	72	67	
Silt (%)	15	17	23	
Clay (%)	12	11	10	

a/ TRPH = total recoverable petroleum hydrocarbons; TVH = total volatile hydrocarbons; mg/kg = milligrams per kilogram, ppmv = parts per million, volume per volume; CaCO₃ = calcium carbonate; TKN = total Kjeldahl nitrogen.

b/ ND = not detected.

TABLE 2.3
PRESSURE RESPONSE (inches of water) DURING THE
AIR PERMEABILITY TEST
SITE 21 JET ENGINE TEST AREA
EDWARDS AFB, CALIFORNIA

Depth (feet)	MP1		MP2		MP3	
	7	11	7	11	7	11
Elapsed Time (min)						
0	0.1	0.04	0.05	0.02	0.01	0.0
1	0.44	0.30	0.08	0.14	0.06	0.06
2	-a/	0.44	0.14	0.18	-	0.10
3	0.68	0.50	0.16	0.24	0.12	0.10
4	0.56	0.52	0.18	0.28	0.16	0.16
5	0.58	0.56	0.22	0.36	0.20	0.22
6	0.84	0.56	0.22	0.28	-	0.18
7	0.8 ^b /	0.40	0.30	0.30	0.18	0.18
8	0.81	0.60	0.28	0.34	0.20	0.20
9	-	0.62	0.28	0.38	0.22	0.20
10	0.18	0.65	0.28	0.32	0.20	0.20
12	0.26	0.70	0.32	0.40	0.20	0.26
14	0.22	0.78	0.36	0.40	0.22	0.26
16	0.32	0.78	0.38	0.48	0.26	0.30
18	0.36	0.84	0.38	0.46	0.26	0.26
20	0.40	0.90	0.40	0.44	0.22	0.22
23	0.44	0.90	0.44	0.48	0.26	0.30
26	0.46	0.90	0.42	0.48	0.22	0.24
29	0.50	1.0	0.46	0.50	0.24	0.26
32	0.52	1.0	0.46	0.52	0.24	0.26
36	0.68	1.0 ^b /	0.50	0.56	0.26	0.32
40	0.68	1.0	0.52	0.58	0.28	0.32
44	0.72	1.2	0.54	0.64	0.28	0.34
48	0.68	1.3	0.52	0.60	0.27	0.32
52	0.70	1.2	0.50	0.58	0.26	0.33
56	0.74	1.2	0.56	0.64	0.30	0.36
60	0.76	1.4	0.62	0.72	0.36	0.40
70	0.92	1.4	0.62	0.68	0.32	0.36
80	-	1.6	0.64	0.70	0.36	0.40
90	0.95	1.6	0.70	0.72	0.40	0.42
100	1.0	1.5	0.64	0.68	0.38	0.40
110	1.0	1.6	-	0.78	0.42	0.46
120	-c/	1.2 ^c /	0.76	0.80	0.42	0.46
130	-	1.8	-	0.83	0.40	0.44
140	0.18	1.6	0.44	0.76	0.42	0.48
150	0.56	1.7	0.56	0.76	0.56	-
160	0.08	1.6	0.66	0.84	0.38	0.32
212	1.3	1.9	0.90	0.90	0.56	0.64

- a/ -- indicates reading not taken at this time point.
b/ Gauge change.
c/ Respiratory readings initiated; pressure released.

2.3.4 Oxygen Influence

The depth and radius of oxygen influence in the subsurface resulting from air injection into the central VW during pilot testing is the primary design parameter for full-scale bioventing systems. Optimization of full-scale and multiple VW systems requires pilot testing to determine the volume of soil that can be oxygenated at a given flow rate and VW screen configuration.

Table 2.4 describes the change in soil gas oxygen levels that occurred during a 49-hour air injection period at the site. This air injection period at 4 acfm produced changes in soil gas oxygen levels at a distance of at least 38 feet from the central VW. Oxygen level increases were measured at MP1-7, MP2-7, and at MP1-11. No reading was able to be taken at MP3-11 as the water level had risen, submerging the monitoring point. The decreased oxygen level observed at MP3-7 was likely the result of oxygen-deficient air from the more highly contaminated central portion of the site being forced outward by the injected air. The lack of oxygen increase at MP2-11 may be attributed to the clay lens blocking oxygen from this MP. The decrease in oxygen levels at the outlying MP3 indicates significant air movement through the soils, and it is likely that oxygenated air will reach both depths of MP2 and MP3 with continuous injection. Based on measured pressure response, which is an indicator of long-term oxygen transport, it is anticipated that the radius of influence for a long-term bioventing system at this site will exceed 38 feet at all depths. Monitoring during the extended pilot test at this site will better define the effective treatment radius.

2.3.5 In Situ Respiration Rates

In situ respiration testing was performed at Site 21 using modified protocol document procedures. Air was injected for a period of 48 hours into the VW using the rotary-vane blower, and into MP2-11 using a 1 cfm blower. Helium also was injected at MP2-11. At the end of the 49-hour period, air injection ceased and changes in soil gas composition were monitored over time. Oxygen, TVH, and carbon dioxide were measured over a period of 65 hours following the air injection period. The observed rates of oxygen utilization were then used to estimate the aerobic fuel degradation rates at Site 21. Figures 2.6 through 2.10 present the results of *in situ* respiration testing at the site, and Table 2.5 provides a summary of the observed oxygen utilization rates.

A 3.9-percent mixture of helium in air was injected into the MP2-11 screened interval, and then the loss of helium was measured for 65 hours following air injection. Because helium is a conservative, inert gas, the change in helium concentrations over time can be useful in determining if significant leakage is occurring due to improper MP construction. Figure 2.11 compares oxygen utilization and helium retention at MP2-11. Helium levels declined at a rate of approximately 77 percent throughout the test, while oxygen concentrations at MP2-11 declined more rapidly with time. Because the observed helium loss was at a slower rate than the observed oxygen loss, and because helium will diffuse approximately three times faster than oxygen, the measured oxygen loss can be primarily attributed to bacterial respiration rather than to diffusion or faulty MP

TABLE 2.4
INFLUENCE OF AIR INJECTION AT VENT WELL
ON MONITORING POINT OXYGEN LEVELS
SITE 21 JET ENGINE TEST AREA
EDWARDS AFB, CALIFORNIA

MP	Distance From VW (ft)	Depth(ft)	Initial O ₂ (%)	Final O ₂ (%) ^{a/}
1	4.9	7	13.6	19.2
2	15.3	7	0.5	13.0
3	38.5	7	9.5	3.0
1	4.9	11	0.0	19.8
2	15.3	11	0.0	0.0
3	38.5	11	2.1	-b/

a/ Reading taken at end of 49-hour air injection period.
b/ No sample taken due to water in monitoring point.

TABLE 2.5
SITE 21 JET ENGINE TEST AREA
OXYGEN UTILIZATION RATES
EDWARDS AFB, CALIFORNIA

MP	O ₂ Loss ^{a/} (%)	Test Duration (min)	O ₂ Utilization ^{a/} Rate (%/min)
VW	16.9	3,940	0.004
MP1-11	20.0	3,950	0.005
MP2-7	12.7	3,960	0.002
MP2-11	15.8	3,970	0.003
MP3-7	3.9	3,980	0.001 ^{b/}

a/ Values based on linear regression (Figures 2.6 through 2.10).

b/ The maximum O₂ achieved in MP3-7 was 12.0%. It is anticipated that over time the O₂ utilization rate at this point will be higher.

Figure 2.6
 Respiration Test
 Site 21: Vent Well
 Edwards AFB, CA

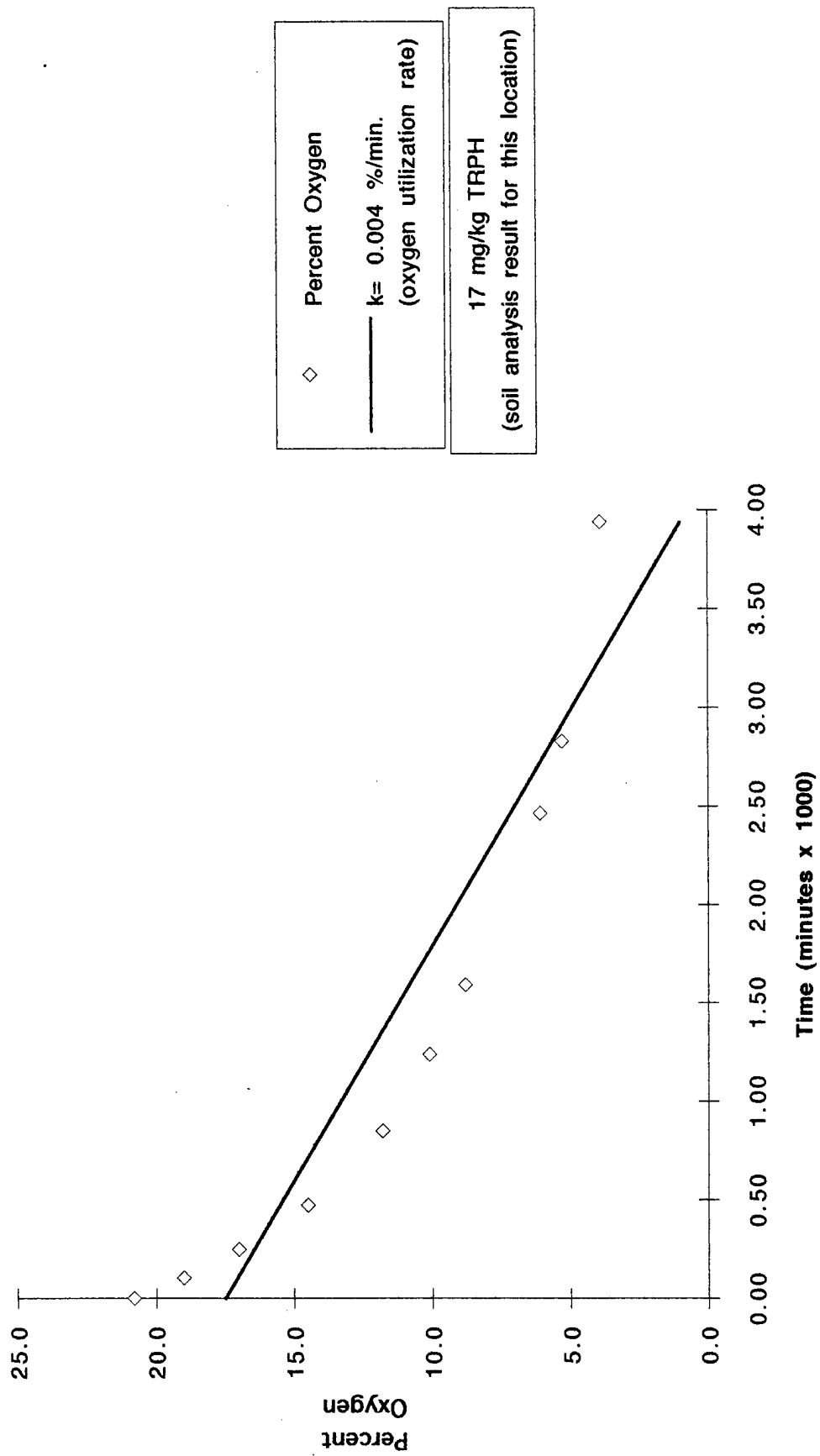

Figure 2.7
Respiration Test
Site 21: MP1-11
Edwards AFB, CA

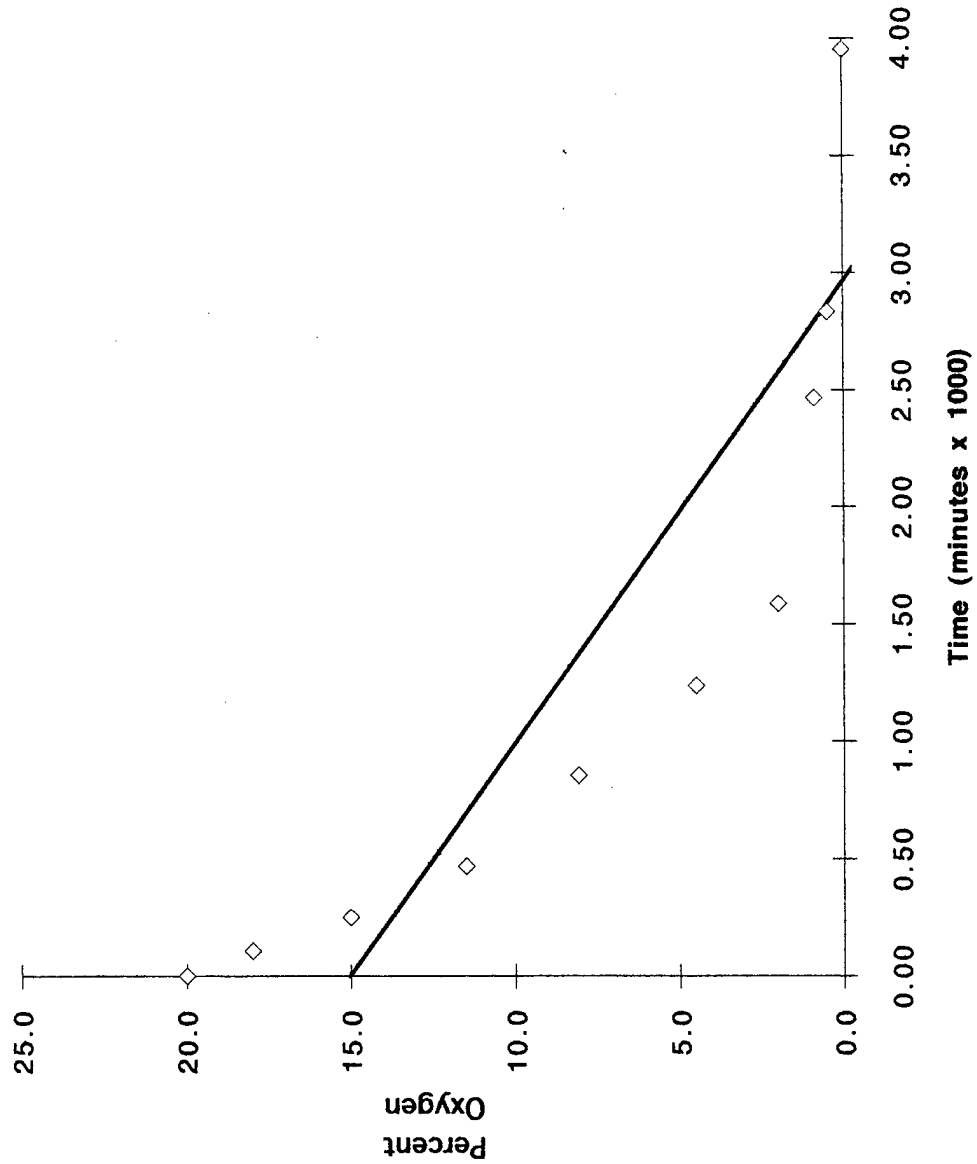

Figure 2.8
Respiration Test
Site 21: MP2-7
Edwards AFB, CA

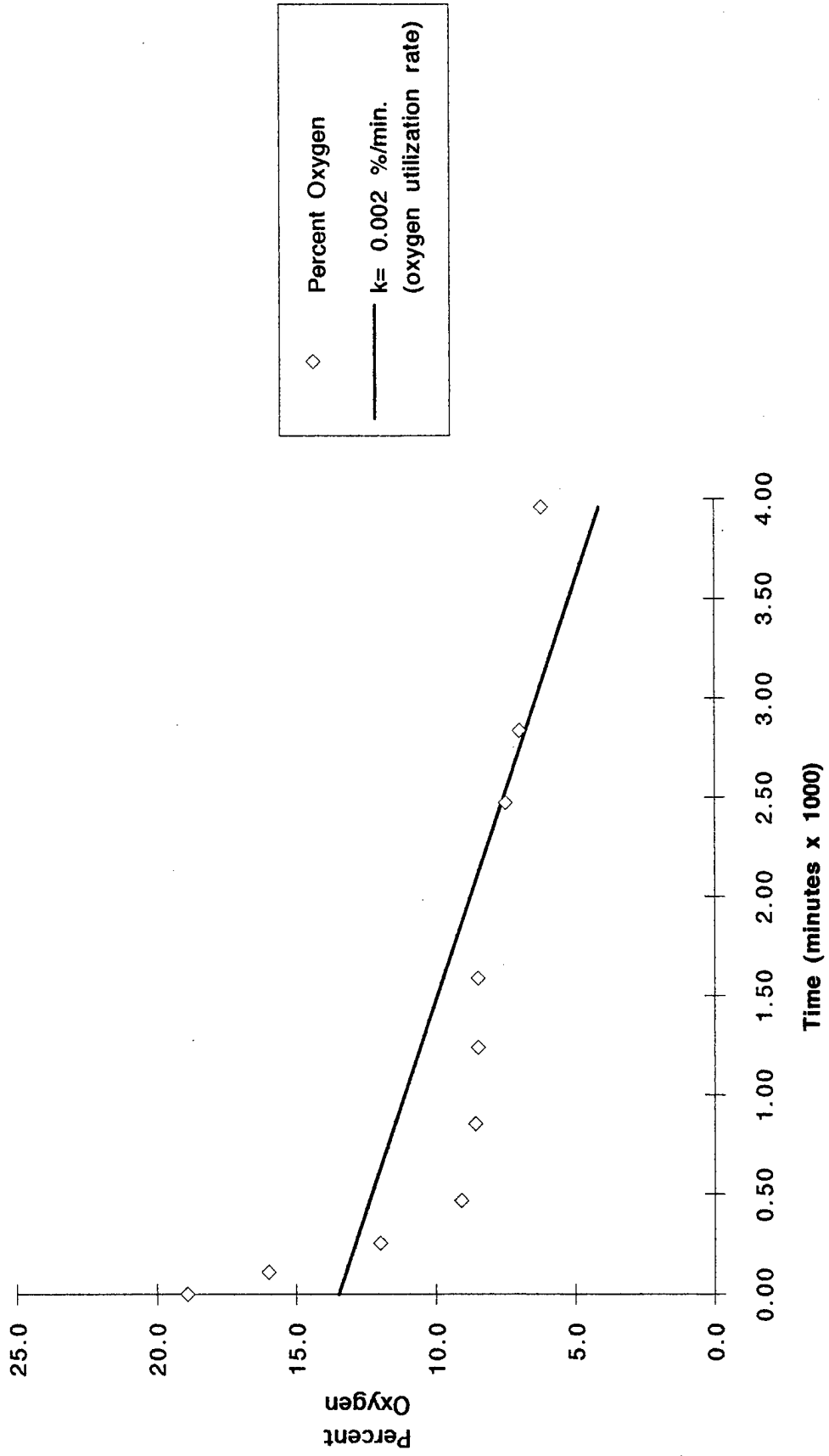

Figure 2.9
 Respiration Test
 Site 21: MP2-11
 Edwards AFB, CA

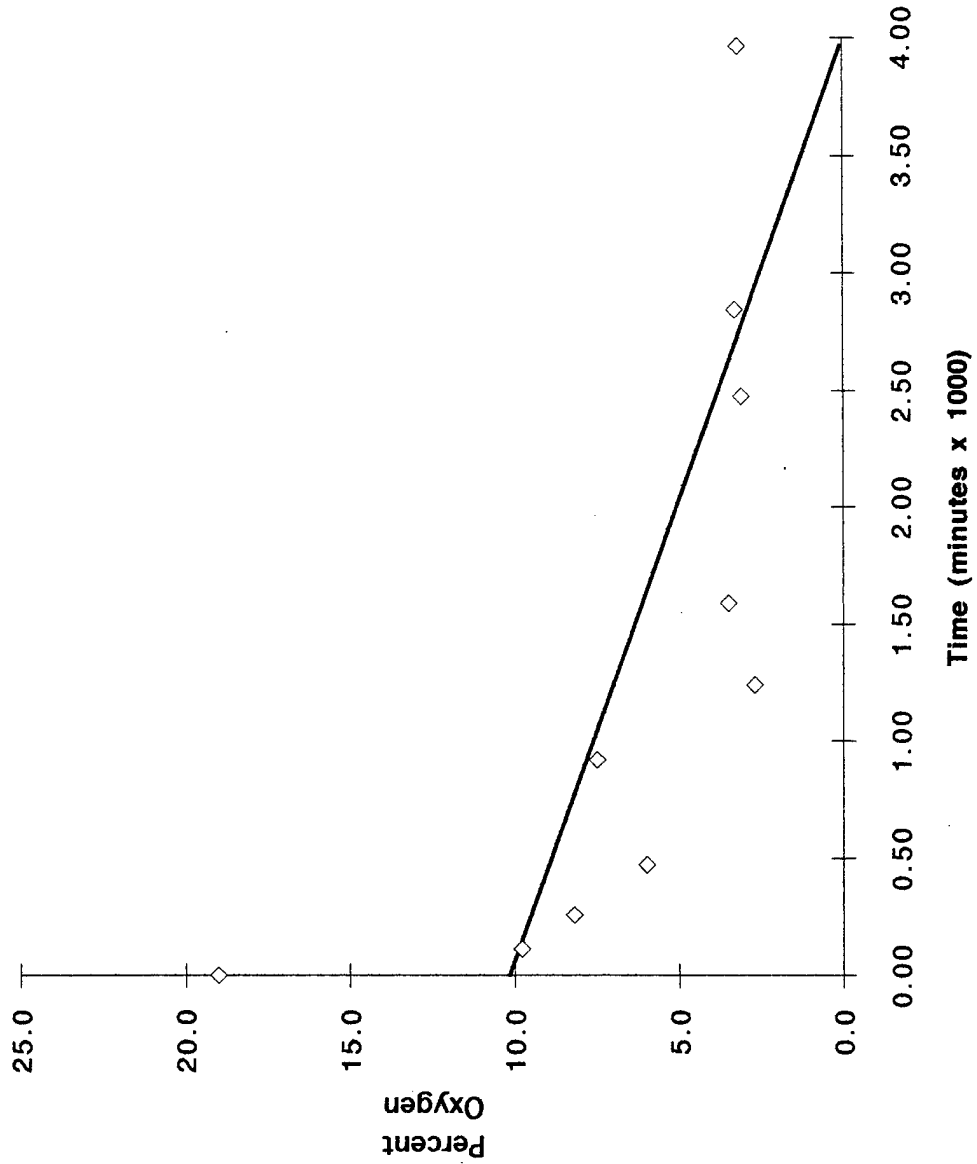

Figure 2.10
Respiration Test
Site 21: MP3-7
Edwards AFB, CA

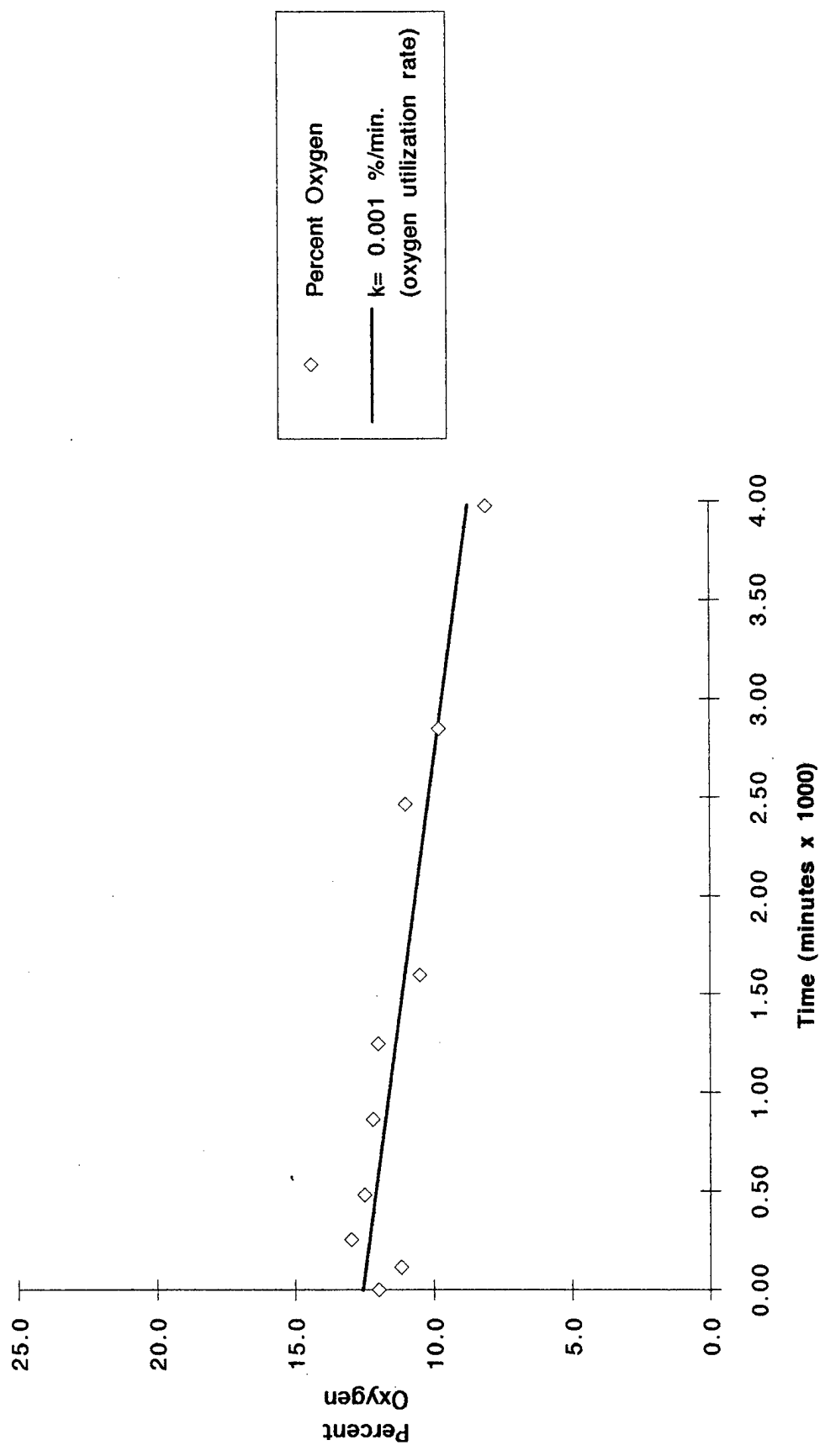
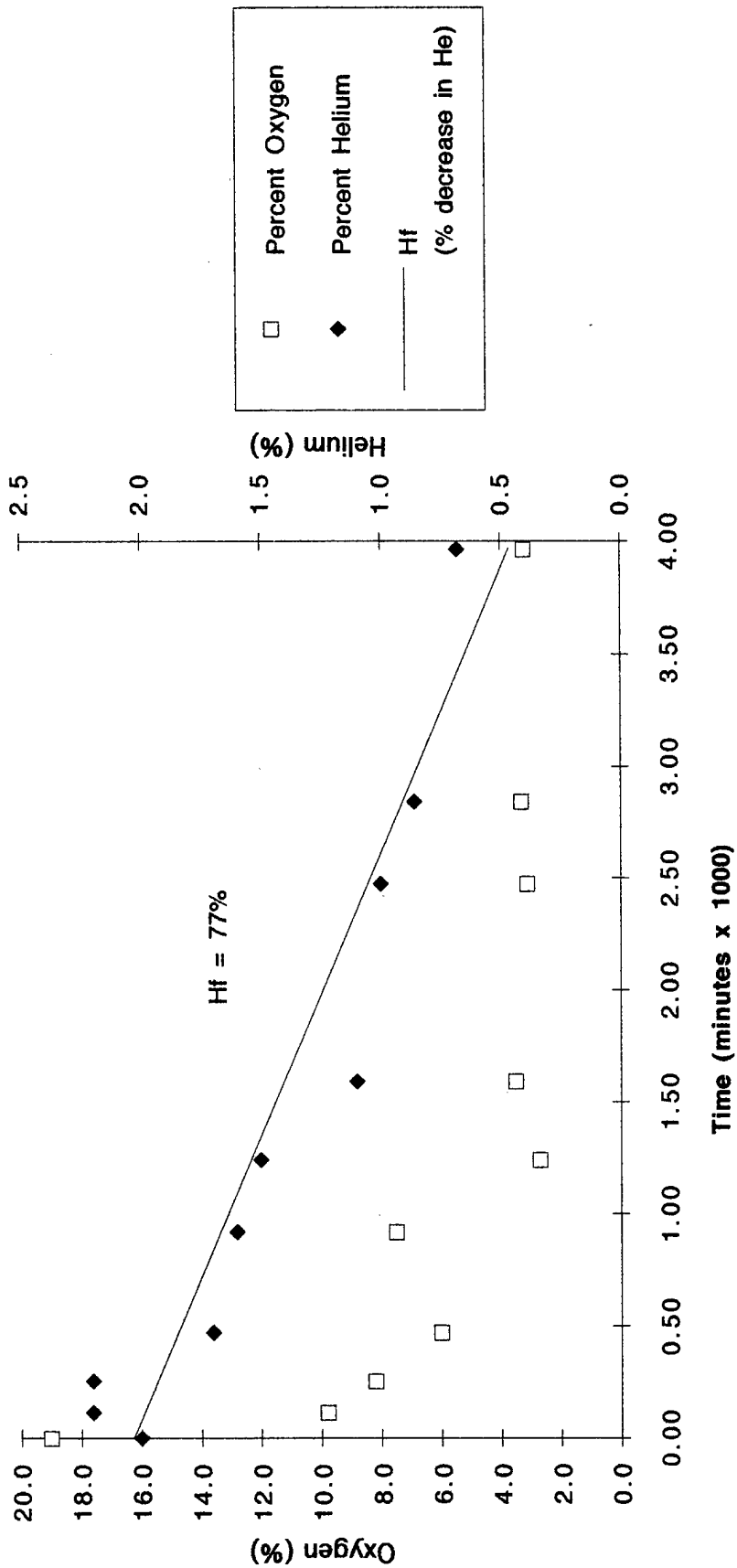

Figure 2.11
 Respiration Test
 Oxygen and Helium Concentrations
 Site 21: MP2-11
 Edwards AFB, CA



construction. Oxygen loss was consistent and linear at every MP during the early stages of the respiration test. Oxygen utilization rates observed at Site 21 ranged from 0.001 %/min to 0.005 %/min (Table 2.5).

At Site 21, an estimated 390 to 760 mg of fuel per kg of soil can be degraded each year. This range is based on every point at which a respiration test was conducted and soil moisture was measured. The MP-specific fuel consumption rates were calculated using observed oxygen utilization rates, an estimated air-filled porosity ranging from 0.09 to 0.21, and a conservative ratio of 3.5 mg of oxygen consumed for every 1 mg of fuel biodegraded.

2.3.6 Potential Air Emissions

Soil concentrations of BTEX compounds detected were less than 17 mg/kg and soil gas concentrations were detected at 196 ppmv (Table 2.1). Based on these BTEX concentrations, the long-term potential for air emissions from full-scale bioventing operations at this site is moderate. No benzene was detected in soil samples, although some benzene still exists in soil gas. Initial emissions were minimal. Accumulated vapors move slowly outward from the air injection point and biodegrade as they move horizontally through the soil. During the air permeability test, air was injected at 4 acfm. Health and safety PID air monitoring of the breathing zone at the site did not indicate that hydrocarbon concentrations had increased above 1 ppmv during the initial days of the test. The initial day of bioventing generally produces the highest potential emissions as the first pore volume of soil is replaced.

2.4 RECOMMENDATIONS

Initial bioventing tests at this site indicate that oxygen has been depleted in the contaminated soils, and that air injection is an effective method of stimulating aerobic fuel biodegradation. AFCEE has recommended that air injection continue at this site to determine the long-term radius of oxygen influence and the effect of time, available nutrients, and changing temperatures on fuel biodegradation rates.

A 1.5-horsepower rotary-vane blower has been installed at the site for continuous air injection. In July 1993, ES will return to the site to sample and analyze the soil gas and conduct a repeat respiration test. In January 1994, a final respiration test will be conducted, and soil and soil gas samples will be collected from the site to determine the degree of remediation achieved during the first year of *in situ* treatment.

Based on the results of the first year of pilot-scale bioventing, AFCEE will recommend one of three options:

1. Upgrade, if necessary, and continue operation of the bioventing system for full-scale remediation of the site. AFCEE can assist the base in obtaining regulatory approval for upgrading and continued operation.
2. If final soil sampling indicates significant contaminant removal has occurred, AFCEE may recommend additional sampling to confirm that cleanup criteria have been achieved.

3. If significant difficulties or poor results are encountered during bioventing at this site, AFCEE may recommend removal of the blower system and proper abandonment of the VW and MPs.

3.0 REFERENCES

Hinchee, R.E., S.K. Ong, R.N. Miller, D.C. Downey, and R. Frandt. 1992. *Test Plan and Technical Protocol for a Field Treatability Test for Bioventing*. Prepared for USAF Center for Environmental Excellence. May.

APPENDIX A
O&M MANUAL

**BIOVENTING SYSTEM
EDWARDS AFB
SITE 1 (IRP16)**

**REGENERATIVE BLOWER OPERATIONS AND MAINTENANCE
MANUAL FOR EXTENDED TESTING SYSTEM**

**Prepared for:
AIR FORCE CENTER FOR ENVIRONMENTAL EXCELLENCE
BROOKS AFB, TEXAS**

USAF CONTRACT F33615-90-D-4010, DELIVERY ORDER 14

March 1993

**Prepared by:
Engineering-Science, Inc.
1700 Broadway, Suite 900
Denver, Colorado**

SECTION 1

INTRODUCTION

This document has been prepared by Engineering-Science, Inc. to support the bioventing initiative contract awarded by the Air Force Center for Environmental Excellence. The contract involves the conducting of bioventing pilot tests at 35 sites on 23 Air Force bases across the United States.

At most sites, bioventing systems will be installed upon completion of the bioventing pilot tests for the purpose of extended pilot testing. These systems will operate for a one year period to provide further information as to the feasibility of the technology at each site, and to provide interim remedial action.

This Operations and Maintenance Manual has been created for sites at which regenerative type blowers have been installed for extended pilot testing. Basic maintenance of these systems is the responsibility of the base. The manual is to be used by base personnel to guide and assist them in operating and maintaining the blower system. Section 2 of this document describes the blower. Section 3 details the maintenance requirements and provides maintenance schedules. Section 4 describes the system monitoring that is required to forecast system maintenance needs and provide data for the extended pilot test. Blower performance curves and relevant service information are provided in Appendix A, and data collection sheets are provided in Appendix B.

SECTION 2

BIOVENTING SYSTEM OPERATION

2.1 PRINCIPLE OF OPERATION

Bioventing is the forced injection of fresh air to enhance the supply of oxygen for in situ bioremediation. A pressure (air injection) blower unit is used to inject air into the soil, thereby supplying fresh air with 20.8 percent oxygen to the contaminated soils. Once oxygen is provided to the subsurface, existing bacteria will proceed with the breakdown of fuel residuals.

At Edwards Air Force Base (AFB) Site 1 (IRP 16) a pressure blower system has been installed.

2.2 SYSTEM DESCRIPTION

2.2.1 Blower System

A pressure (injection) blower powered by a 2.5 horsepower direct-drive motor is the workhorse of the bioventing system. This blower is rated at 160 scfm at 55 inches of water pressure; however, the actual performance of the blower will vary with changing site conditions. As installed, the blower was producing an estimated flow rate of 105 scfm at 45 inches of water. All systems include an air filter to remove any particulates which are entrained in the air stream and several valves and monitoring gauges which are described in the next section. A schematic of the blower system installed at Edwards AFB, corresponding blower performance curves, and relevant service information are provided in Appendix A.

2.2.2 Monitoring Gauges

The bioventing system is equipped with vacuum and pressure gauges and temperature gauges. Generally, gauges have been installed on the air injection system at the following locations; a vacuum gauge in the inlet piping and a pressure gauge in the outlet piping. See Figure 1 in Appendix A for the locations of the gauges installed on the blower system at this site.

A temperature gauge is located at the outlet of the blower system. This gauge is used to monitor the inlet and outlet temperature to determine the change in temperature across the blower. For air injection systems ambient air temperature should be used when an inlet temperature gauge is not present.

SECTION 3

SYSTEM MAINTENANCE

3.1 BLOWER/MOTOR MAINTENANCE

Although the motor is relatively maintenance free, the blower requires periodic maintenance for proper operation and long life. Recommended maintenance procedures and schedules are described in detail in the instruction manual included in Appendix A and briefly summarized in this section.

Filter inspection must be performed with the system turned off. To re-start the motor, open the manual air dilution valve (red handle) to protect the motor from excessive strain, start motor, and slowly close dilution valve to its original setting.

3.1.1 Lubrication

Regenerative blowers require no lubrication.

3.2 KNOCK-OUT CHAMBER MAINTENANCE

This section applies only to vapor extraction systems equipped with moisture knock-out pots and is not applicable to the blowers at Edwards AFB.

3.3 AIR FILTER MAINTENANCE

To avoid damage caused by passing solids through the blower an air filter has been installed in-line before the blower.

The filter element is paper and is accompanied by a polyurethane foam prefilter. The filter should be checked weekly for the first two months of operation. Again, a base employee should determine the best schedule for filter replacement. The polyurethane prefilters can be washed with lukewarm water and a mild detergent. Paper filter elements should never be washed but should be disposed of and replaced as necessary. When the inlet vacuum reads above 10-12 inches of water, a dirty filter element should be suspected and cleaning or replacement should be performed.

To remove the filter, loosen the three clamps or the wing nut, lift the metal top off the air filter, and lift the air filter from the metal housing. Remove the polyurethane prefilter (if applicable) and wash before replacing. When replacing the filter, be careful that the rubber seals remain in place.

The filter is manufactured by Solberg Manufacturing, Inc. in Itasca, Illinois. Their phone number is (708) 773-1363. Additional filters can also be obtained through Engineering-Science, Inc. in Denver, Colorado. The ES contacts are Mr. Brian Blicher and Mr. Robert Williams and they can be reached at (303) 831-8100. The filter model number is AJ126D, and the number for the replacement element is AJ134E. It is recommended that Edwards AFB keep at least one spare air filter at the site; six spare filters were supplied with the blower system.

3.4 MAINTENANCE SCHEDULE

The following maintenance schedule is recommended for this system. During the initial months of operation more frequent monitoring is recommended to ensure that any start up problems are quickly corrected. A daily drive-by inspection is recommended during the initial two weeks of operation to ensure that the blower system is still operating with no unusual sounds. Data collection sheets have been provided to assist your data collection and are included in Appendix B.

<u>Maintenance Item</u>	<u>Maintenance Frequency</u>
Filter	Check once per month.

3.5 MAJOR REPAIRS

Blower systems are very reliable when properly maintained. Occasionally, a motor or blower will develop serious problems. If a blower system fails to start, and a base electrician verifies that power is available at the starter, the Engineering-Science site manager, Gail Saxton, should be called at (303) 831-8100, or call Chris Pluhar at (818) 585-6000. Engineering-Science is responsible for major repairs during the first year of operation.

SECTION 4

SYSTEM MONITORING

4.1 BLOWER PERFORMANCE MONITORING

To monitor the blower performance, vacuum, pressure and temperature will be measured. These data should be recorded weekly on a data collection sheet provided in Appendix B. All measurements should be taken at the same time while the system is running. Since the system is loud, ear protection should be worn at all times.

4.1.1 Vacuum/Pressure

With ear protection on, open the enclosure and record all vacuum and pressure readings directly from the gauges (in inches of water). Record the measurements on the data collection sheet provided in Appendix B.

4.1.2 Flow Rate

The flow rate through the vent well and soils can be calculated when the inlet vacuum and outlet pressure of the blower are known. This pressure change across the blower (vacuum + pressure) can be compared to the performance curves for the blower in Appendix A to determine the approximate flow rate.

4.1.3 Temperature

With ear protection on, open the enclosure and record the temperature readings directly from the gauges in degrees Fahrenheit. Record the measurements on the data collection sheet provided in Appendix B. The temperature change can be converted to degrees Celsius ($^{\circ}\text{C}$) using the formula $^{\circ}\text{C} = (^{\circ}\text{F} - 32) \times 5/9$.

4.3 MONITORING SCHEDULE

The following monitoring schedule is recommended for this system. During the initial months of operation more frequent monitoring is recommended to ensure that any start up problems are quickly corrected. Data collection sheets have been provided to assist your data collection and are included in Appendix B.

<u>Monitoring Item</u>	<u>Monitoring Frequency</u>
Vacuum/Pressure	Daily during first week, then once per week.
Temperature	Daily during first week, then once per week.

APPENDIX A

REGENAIR® R5 Series

MODEL R5325A-2
 65" H₂O MAX. PRESSURE, 160 CFM OPEN FLOW

PRODUCT FEATURES

- Oilless operation
- TEFC motor mounted
- Can be mounted in any plane
- Rugged construction/low maintenance

COMMON MOTOR OPTIONS

- 115/208-230V, 60 Hz, single phase
- 208-230/480V, 60 Hz; 190-220/380-415V, 50 Hz, three phase
- 575V, 60 Hz, three phase

RECOMMENDED ACCESSORIES

- Pressure gauge AE133
- Filter AG338
- Muffler AJ121D
- Relief valve AG258

Various brand name motors are used on any model at the discretion of Gast Mfg. Corp.

Important Notice:

Pictorial and dimensional data is subject to change without notice.

Product Dimensions Metric (mm) U.S. Imperial (Inches)

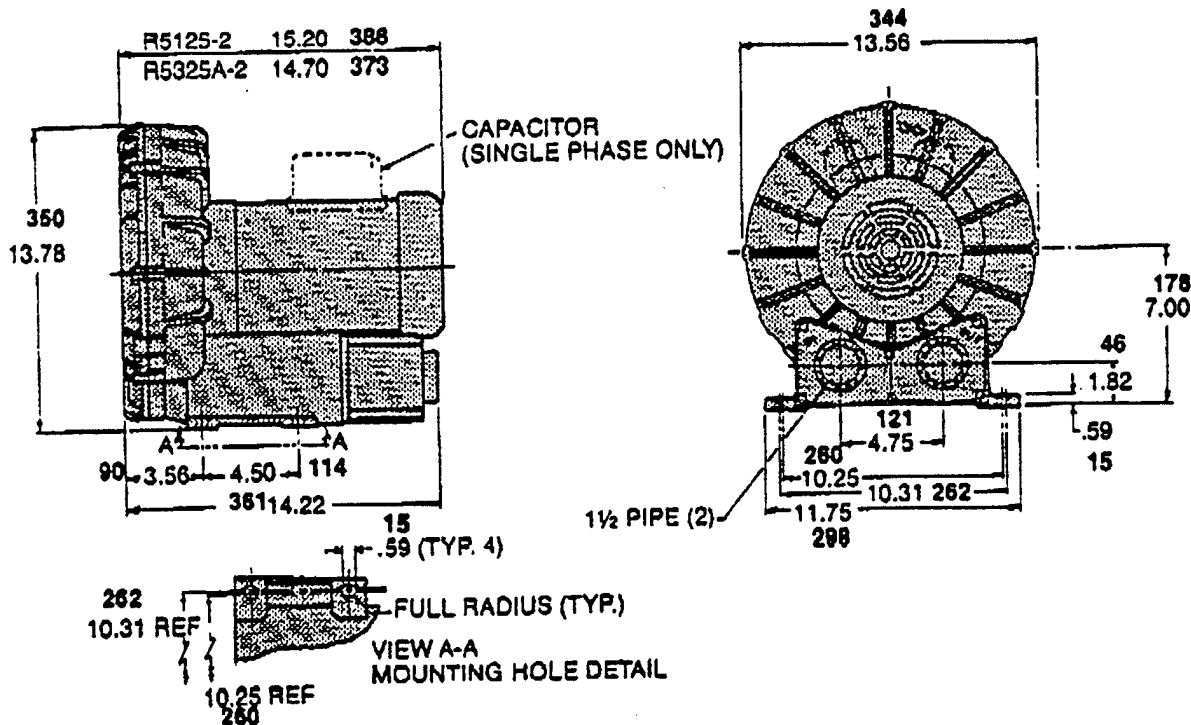

Product Specifications

Model Number	Motor Specs	Full Load Amps	HP	RPM	Max Vac		Max Flow		Net Wt.	
					"H ₂ O	mbar	cfm	m ³ /h	lbs.	kg
R5325A-2	190-220/380-415-50-3	6.6-6.7/3.3-3.5	1.35	2850	47	117	120	204	65	29.5
	208-230/460-3	6.9/3.45	2.5	3450	60	149	145	246	73	33.1
R5125-2	115/208-230-60-1	22.4/12.4-11.2	2.5	3450	60	149	145	246		

Product Performance (Metric U.S. Imperial) Black line on curve is for 60 cycle performance.
Blue line on curve is for 50 cycle performance.

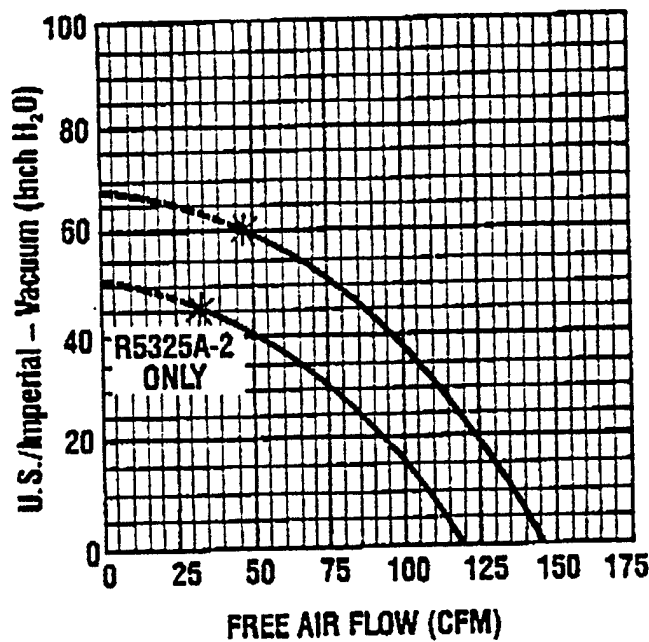
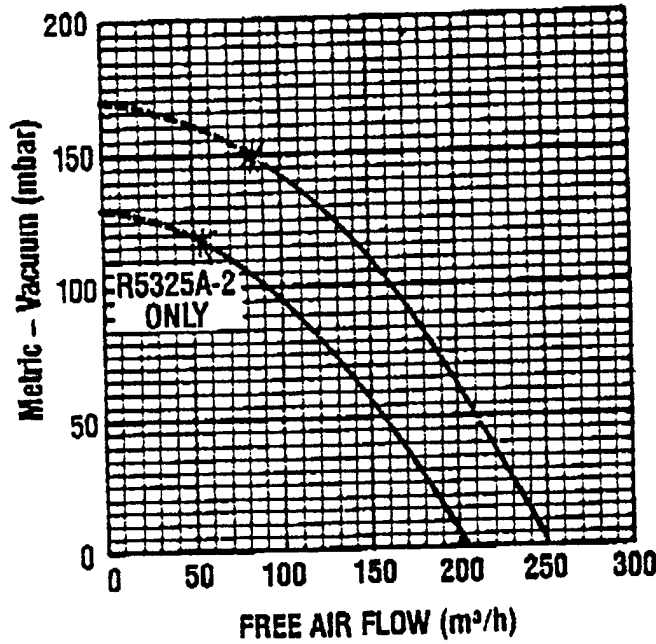

*Recommended maximum duty.
 Intermittent duty only.

APPENDIX B

**BIOVENTING SYSTEM
EDWARDS AFB
SITE 2 (IRP21)**

**REGENERATIVE BLOWER OPERATIONS AND MAINTENANCE
MANUAL FOR EXTENDED TESTING SYSTEM**

**Prepared for:
AIR FORCE CENTER FOR ENVIRONMENTAL EXCELLENCE
BROOKS AFB, TEXAS**

USAF CONTRACT F33615-90-D-4010, DELIVERY ORDER 14

March 1993

**Prepared by:
Engineering-Science, Inc.
1700 Broadway, Suite 900
Denver, Colorado**

SECTION 1

INTRODUCTION

This document has been prepared by Engineering-Science, Inc. to support the bioventing initiative contract awarded by the Air Force Center for Environmental Excellence. The contract involves the conducting of bioventing pilot tests at 35 sites on 23 Air Force bases across the United States.

At most sites, bioventing systems will be installed upon completion of the bioventing pilot tests for the purpose of extended pilot testing. These systems will operate for a one year period to provide further information as to the feasibility of the technology at each site, and to provide interim remedial action.

This Operations and Maintenance Manual has been created for sites at which regenerative type blowers have been installed for extended pilot testing. Basic maintenance of these systems is the responsibility of the base. The manual is to be used by base personnel to guide and assist them in operating and maintaining the blower system. Section 2 of this document describes the blower. Section 3 details the maintenance requirements and provides maintenance schedules. Section 4 describes the system monitoring that is required to forecast system maintenance needs and provide data for the extended pilot test. Blower performance curves and relevant service information are provided in Appendix A, and data collection sheets are provided in Appendix B.

SECTION 2

BIOVENTING SYSTEM OPERATION

2.1 PRINCIPLE OF OPERATION

Bioventing is the forced injection of fresh air, or withdrawal of soil gas, to enhance the supply of oxygen for in situ bioremediation. Either a pressure (air injection) or vacuum (vapor extraction) blower unit is used to inject or withdraw air into or from the soil, thereby supplying fresh air with 20.8 percent oxygen to the contaminated soils. Once oxygen is provided to the subsurface, existing bacteria will proceed with the breakdown of fuel residuals.

At Edwards Air Force Base (AFB) an injection rotary vane blower system has been installed.

2.2 SYSTEM DESCRIPTION

2.2.1 Blower System

A rotary vane blower powered by a 1.5 horsepower direct-drive motor is the workhorse of the bioventing system. This blower is rated at 16 scfm at 15 psi; however, the actual performance of the blower will vary with changing site conditions. As installed, the blower was producing an estimated flow rate of 20 scfm at 40 inches of water. Vapor extraction systems may include an inlet knockout chamber for water condensation. All systems include an air filter to remove any particulates which are entrained in the air stream and several valves and monitoring gauges which are described in the next section. A schematic of the blower system installed at Edwards AFB, corresponding blower performance curves, and relevant service information are provided in Appendix A.

2.2.2 Monitoring Gauges

The bioventing system is equipped with vacuum and pressure gauges, temperature gauges, and a sampling port (vapor extraction only). Generally, gauges have been installed on the air injection system at the following locations; a vacuum gauge in the inlet piping and a pressure gauge in the outlet piping. For vapor extraction systems gauges are generally installed as follows; vacuum gauges in the inlet piping and at the knock-out pot (as applicable), and a pressure gauge in the discharge piping. See Figure 1 for the locations of the gauges installed on the blower system at this site.

Temperature gauges may be located at the inlet and outlet of the blower system. These gauges are used to monitor the inlet and outlet temperature to determine the change in temperature across the blower. For air injection systems ambient air temperature should be used when an inlet temperature gauge is not present. For vapor extraction systems the inlet temperature is also used as an estimate of soil gas temperatures in the contaminated soil zone. See Figure 1 for the location(s) of the temperature gauges installed on the blower system at this site.

A sample port is located in the discharge piping on the outlet side of vapor extraction systems only. This sample port is used to collect offgas that is analyzed for CO₂/O₂ and volatile organics concentrations. See Figure 1 for the location of the sampling port installed on the blower system at this site.

SECTION 3

SYSTEM MAINTENANCE

3.1 BLOWER/MOTOR MAINTENANCE

Although the motor is relatively maintenance free, the blower requires periodic maintenance for proper operation and long life. Recommended maintenance procedures and schedules are described in detail in the instruction manual included in Appendix A and briefly summarized in this section.

Filter inspection and knock-out pot draining (as applicable) must be performed with the system turned off. To re-start the motor, open the manual air dilution valve (red handle) to protect the motor from excessive strain, start motor, and slowly close dilution valve to its original setting.

3.1.1 Lubrication

Regenerative blowers require no lubrication.

3.2 KNOCK-OUT CHAMBER MAINTENANCE

This section applies only to vapor extraction systems equipped with moisture knock-out pots. To avoid damage caused by passing liquids or solids through the blower a knock-out pot has been installed in-line before the blower.

Free liquid should not be pumped through the blower. The knock-out pot installed in-line before the blower intercepts entrained liquid, preventing damage to the blower. The knock-out pot should be drained once a month for the first few months and at longer intervals thereafter, if it appears that this will be sufficient to keep liquid from building up in the knock-out pot. Condensation generally increases during the cold winter months. A base employee should determine the best schedule to drain the knock-out pot. The knock-out pot can be drained by turning the system off and removing the 2" diameter cap at the base of the knock-out pot. When all of the liquid has drained out the system can be turned back on. It is recommended when re-starting the system that the air dilution valve (red-handled valve) be opened to protect the motor from excessive strain. If oily, liquids should be disposed of in an oil-water separator.

3.3 AIR FILTER MAINTENANCE

To avoid damage caused by passing solids through the blower an air filter has been installed in-line before the blower.

The filter element is paper and is accompanied by a polyurethane foam prefilter. The filter should be checked weekly for the first two months of operation. Again, a base employee should determine the best schedule for filter replacement. The polyurethane prefilters can be washed with lukewarm water and a mild detergent. Paper filter elements should never be washed but should be disposed of and replaced as necessary. When the pressure or vacuum drop across the filter is above 15 inches of water, a dirty filter element should be suspected and cleaning or replacement should be performed.

To remove the filter, loosen the three clamps or the wing nut, lift the metal top off the air filter, and lift the air filter from the metal housing. Remove the polyurethane prefilter (if applicable) and wash before replacing. When replacing the filter, be careful that the rubber seals remain in place.

The filter is manufactured by Solberg Manufacturing, Inc. in Itasca, Illinois. Their phone number is (708) 773-1363. Additional filters can also be obtained through Engineering-Science, Inc. in Denver, Colorado. The ES contacts are Mr. Brian Blicher or Mr. Robert Williams and they can be reached at (303) 831-8100. The filter model number is D344B, and the number for the replacement element is D344B. It is recommended that Edwards AFB keep at least one spare air filter at the site. No spare filters were supplied with the blower system; they will be mailed to Edwards AFB.

3.4 MAINTENANCE SCHEDULE

The following maintenance schedule is recommended for this system. During the initial months of operation more frequent monitoring is recommended to ensure that any start up problems are quickly corrected. A daily drive-by inspection is recommended during the initial two weeks of operation to ensure that the blower system is still operating with no unusual sounds. Data collection sheets have been provided to assist your data collection and are included in Appendix B.

<u>Maintenance Item</u>	<u>Maintenance Frequency</u>
Filter	Check once per month.

3.5 MAJOR REPAIRS

Blower systems are very reliable when properly maintained. Occasionally, a motor or blower will develop serious problems. If a blower system fails to start, and a base electrician verifies that power is available at the starter, the Engineering-Science site manager, Gail Saxton, should be called at (303) 831-8100, or Chris Pluhar at (818) 585-6000. Engineering-Science is responsible for major repairs during the first year of operation.

SECTION 4

SYSTEM MONITORING

4.1 BLOWER PERFORMANCE MONITORING

To monitor the blower performance, vacuum, pressure and temperature will be measured. These data should be recorded weekly on a data collection sheet provided in Appendix B. All measurements should be taken at the same time while the system is running. Since the system is loud, ear protection should be worn at all times.

4.1.1 Vacuum/Pressure

With ear protection on, open the enclosure and record all vacuum and pressure readings directly from the gauges (in inches of water). Record the measurements on the data collection sheet provided in Appendix B.

4.1.2 Flow Rate

The flow rate through the vent well and soils can be calculated when the inlet vacuum and outlet pressure of the blower are known. This pressure change across the blower (vacuum + pressure) can be compared to the performance curves for the blower in Appendix A to determine the approximate flow rate.

4.1.3 Temperature

With ear protection on, open the enclosure and record the temperature readings directly from the gauges in degrees Fahrenheit. Record the measurements on the data collection sheet provided in Appendix B. The temperature change can be converted to degrees Celsius ($^{\circ}\text{C}$) using the formula $^{\circ}\text{C} = (^{\circ}\text{F} - 32) \times 5/9$.

4.3 MONITORING SCHEDULE

The following monitoring schedule is recommended for this system. During the initial months of operation more frequent monitoring is recommended to ensure that any start up problems are quickly corrected. Data collection sheets have been provided to assist your data collection and are included in Appendix B.

<u>Monitoring Item</u>	<u>Monitoring Frequency</u>
Vacuum/Pressure	Daily during first week, then once per week.
Temperature	Daily during first week, then once per week.

APPENDIX A

70-230
G360PL
7-89



MANUFACTURING CORPORATION

P. O. BOX 97, BENTON HARBOR, MICHIGAN 49022
PHONE 616-926-6171

**PARTS LIST and OPERATING
INSTRUCTIONS
1067, 2067, and 2567**

**OIL LESS
VACUUM PUMPS
and
COMPRESSORS**

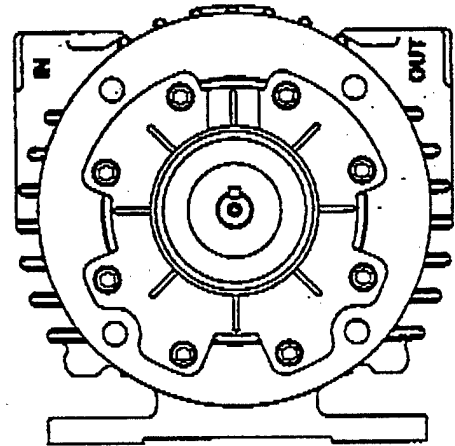
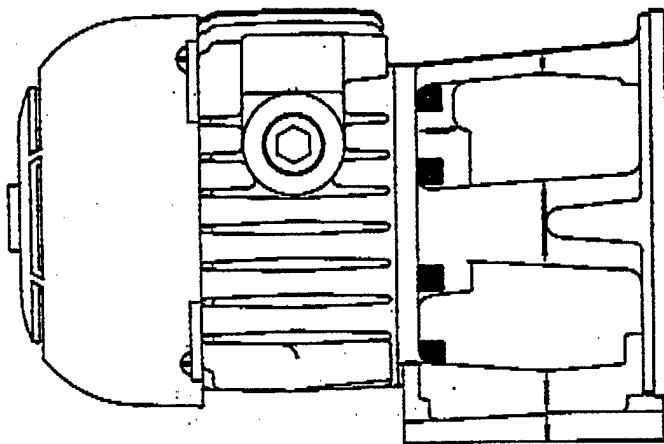

**WARNING: UNIT SHOULD NOT PUMP EXPLOSIVE GASES OR
BE USED IN EXPLOSIVE AMBIENTS.**

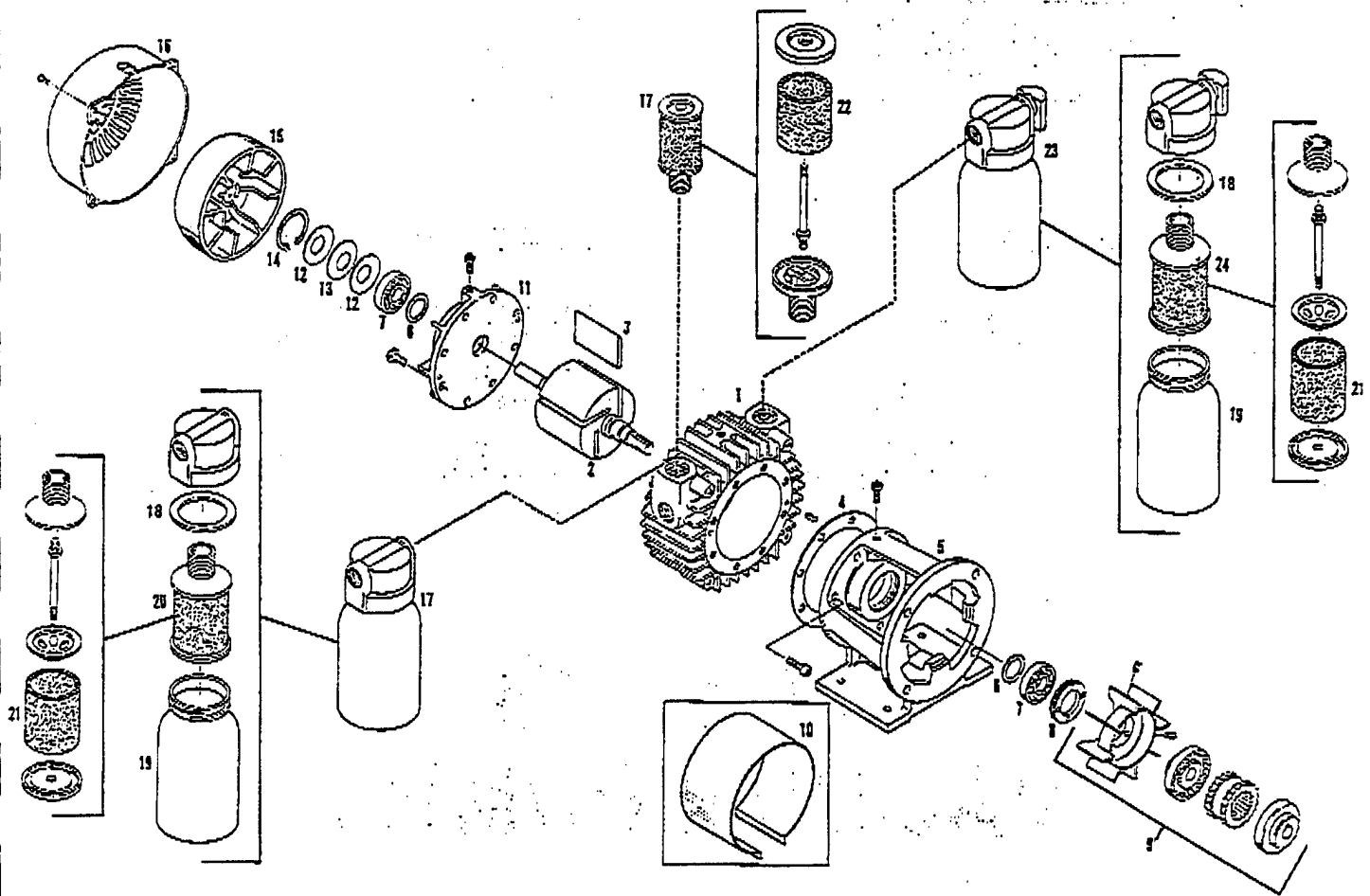

REF. NO.	DESCRIPTION	PART QNTY.	1067-V100	1067-P102	2067-V100	2067-P102	2567-V100	2567-P102
1	Body	1	AH346	AH346	AH191	AH191	AH356	AH355
2	Rotor Assembly	1	AH428	AH428	AH192	AH192	AH192	AH192
3	Vane	4	AH430	AH430	AH196	AH196	AH196	AH196
4	Body Gasket	1	AH567	AH567	AH607	AH567	AH567	AH567
5	Foot Bracket	1	AH208	AH208	AH208	AH208	AH208	AH208
6	Deflector	2	AH193	AH193	AH193	AH193	AH193	AH193
7	Ball Bearing (Drive & Dead)	2	AC894	AC894	AC894	AC894	AC894	AC894
8	End Cap, Drive	1	AB339A	AB339A	AB339A	AB339A	AB339A	AB339A
9	Fan Coupling Assembly	1	AH198	AH198	AH198	AH198	AH198	AH198
10	Fan Guard	1	AH194	AH194	AH194	AH194	AH194	AH194
11	End Plate Dead	1	AH205	AH205	AH205	AH205	AH205	AH205
12	Bellville Springs	2	AB337	AB337	AB337	AB337	AB337	AB337
13	Washer	1	AB338	AB338	AB338	AB338	AB338	AB338
14	Snap Ring	1	AB336	AB336	AB336	AB336	AB336	AB336
15	Fan	1	AC326B	AC326B	AC326B	AC326B	AC326B	AC326B
16	Fan Guard	1	AC102B	AC102B	AC102B	AC102B	AC102B	AC102B
17	Intake Filter Assembly	1	AA900C	AA905F	AA900D	AA905G	AA900D	AA905G
18	Gasket	2	AA405		AA405		AA405	
19	Jar	2	AA401		AA401		AA401	
20	Filter Assembly	1	AC435-1		AC435-1		AC435-1	
21	Cartridge	2	AC393	AC393	AC393		AC393	
22	Filter Felt	1		D344B		D344B		D344B
23	Muffer	1	AA900F		AA900F		AA900F	
24	Muffer Assembly	1	AC434-1		AC435-1		AC435-1	
	Service Kit		K356	K356	K350	K357	K350	K357

• Denotes parts in service kit.
When corresponding or ordering spare parts, please give complete model and serial numbers.

OPERATING AND MAINTENANCE INSTRUCTIONS

CONSTRUCTION: The end plate, body, rotor and foot bracket are all cast iron. Consequently any moisture that accumulates in the pump will tend to corrode the interior especially if it stands idle. The vanes are made of hard carbon and are precision ground. They should last 5,000 to 10,000 hours depending upon the degree of vacuum pressure at which the pump is run.

STARTING: CAUTION: NEVER LUBRICATE THIS OILLESS AIR PUMP. The carbon vanes and grease packed motor bearings require no oil. If the motor fails to start or slows down when under load shut the unit off and unplug. Check that the supply voltage agrees with the motor post terminals and the motor data name plate. **CAUTION: ALL DUAL VOLTAGE MOTORS ARE SHIPPED FROM THE FACTORY WIRED FOR THE HIGH VOLTAGE.** If the pump is extremely cold allow it to warm to room temperature before starting. If anything appears to be wrong with the motor return the complete pump to an authorized Gast service facility.

To minimize noise and vibration the unit should be mounted on a solid surface that will not resonate. Use of shock mounts or vibration isolation material is recommended. Inlet or discharge noise can be minimized by attaching the muffler. The unit should not be allowed to operate in ambient air temperatures in excess of 40°C (104°F). If the motor fails to start or slows down when under load shut the unit off and unplug. Check that the supply voltage agrees with the motor post terminal setup and the motor data name plate.

FILTRATION: Care must be taken to insure that any particles (dirt, chips, foreign material) often found in new plumbing not be allowed to enter the unit. Liquid, moisture vapor, or oil based contaminants will affect pump performance and must be filtered from entering the pump.

Dirty filters restrict air flow and if not corrected could lead to possible motor overload, poor performance and early pump failure. Check filters periodically and clean when necessary by removing felts and washing in Gast flushing solvent (part number AH255). Dry with compressed air and replace.

FLUSHING: Should excessive dirt, foreign particles, moisture, or oil be permitted to enter the pump the vanes

will act sluggish or even break. Flushing the pump should remove these materials. First remove the filter & muffler clean with solvent & dry with compressed air.

DISASSEMBLY: Begin by removing the fan guard and fan. The dead end plate may be removed using a wheel puller. The vanes and body area can then be inspected for damage or further cleaning. Unless scoring is visible do not remove drive end plate and top clearance will be maintained. If further repair is required remove the spanner nut before using a wheel puller to remove the drive end plate. Both bearings are a press fit on the shaft.

REASSEMBLY: First attach the drive end plate (but do not tighten bolts) and press the bearing on the shaft (be sure to properly support the inner race). If required top clearance (between rotor & body) should then be set (for 1067 models it is .0015 and for 2067 and 2567 it is .003). Now replace the dead end plate and bearing. Then the bellville springs, washer and snap ring should be replaced. With a dial indicator on the dead end shaft to show any movement, install spanner nut (with adhesive to keep from vibrating loose) until indicator moves .002-.0025. Check shaft for ease of rotation.

HAZARD PREVENTION:

WARNING: MAKE SURE THE ELECTRIC MOTOR IS PROPERLY GROUNDED AND THE WIRING IS DONE BY A QUALIFIED ELECTRICIAN FAMILIAR WITH NEMA MG2 SAFETY STANDARDS, NATIONAL ELECTRIC CODE AND ALL LOCAL SAFETY CODES.

WARNING: THE ELECTRIC MOTOR MAY BE THERMALLY PROTECTED AND WILL AUTOMATICALLY RESTART WHEN THE PROTECTOR RESETS.

WARNING: WHEN SERVICING ALL POWER TO THE MOTOR MUST BE DE-ENERGIZED AND DISCONNECTED. ALL ROTATING COMPONENTS MUST BE AT A STAND STILL.

WARNING: DO NOT USE KEROSENE OR OTHER COMBUSTIBLE SOLVENTS OR OPERATE PUMP IN EXPLOSIVE AMBIENTS.

Performance Data

Model	Vacuum			Maximum Vacuum
	0" HG	10" HG	20" HG	
1067	8.5 CFM	5.0 CFM	2.0	26" HG
2067	16.0	9.0	3.0	27"
2567	20.0	13.0	5.0	27"

Model	Pressure			
	0 PSI	5 PSI	10 PSI	15 PSI
1067	8.5 CFM	7.5 CFM	7.0 CFM	6.5 CFM
2067	17.0	14.0	12.0	11.0
2567	21.0	19.0	17.0	16.0

Gast Manufacturing Co., Ltd.
Coronation Road, Cressex Estate
High Wycombe, Bucks HP12 3SN
England 23571
FAX 444-943-6588

Gast Manufacturing Corp.
2550 Meadowbrook Road
Benton Harbor MI 49022
616/926-6171
FAX 616-925-8288

Gast Manufacturing Corp.
505 Washington Ave.
Carlstadt NJ 07072
201/933-8484
FAX 201-933-5545

Brenner-Fiedler & Assoc.
13824 Bentley Place
Cerritos, Ca. 90701
213-404-2721
FAX 213-404-7975

Wainbec, Ltd.
121 City View Drive
Rexdale, Ontario, Canada M9W 5A9
416/243-1900
FAX 416-243-2336

Wainbec, LTD.
215 Brunswick Blvd.
Pointe Claire, Montreal
Canada H9R 4R7
514/697-8810
FAX 514-697-3070

Note: All general correspondence should be directed to Gast Mfg Corp, P.O. Box 97, Benton Harbor, MI 49022

CHECK VALVES—vacuum		
AE236	1/4" NPT, male	
AJ550	1/4" NPT, female	
AB50A	3/8" NPT, female	
CHECK VALVES—vacuum swing		
AH325A	3/4" NPT	
AH325B	1" NPT	
CORDS—ELECTRIC		
AA816	1/2" 1/2" 3/4" hp, 115V without switch, 10 ft.	
AA819	1/2" 3/4" hp, 230V without switch, 10 ft.	
AA895	1/2" 1/4" 1/4" hp, 115 V with switch, 10 ft.	
FILTERS—no jars		
AC432	3/4" female NPS, 10 micron	
AC433	1/2" male NPS, 10 micron	
AC435	3/4" male NPS, 10 micron	
AA505E	3/4" female NPS, 50 micron	
AA505F	1/2" male NPS, 50 micron	
AA505G	3/4" male NPS, 50 micron	
B300A	1/2" male NPS, 50 micron	
B343B	1/2" male NPS, 50 micron	
AD750	1" male NPS, 50 micron	
FILTERS—glass jar		
AA617G	1/4" NPS, 2 oz., 50 micron	
AA922H	1/4" NPS, 3/4" oz., 50 micron	
AD560	1" NPS, 2 qt., 50 micron	
AB599	3/4" NPS, 1 pt., 10 micron	
AB599D	3/4" NPS, 1 pt., 50 micron	
AB600	1/2" NPS, 1 pt., 50 micron	
AB600F	1/2" NPS, 1 pt., 10 micron	
AB601B	3/4" NPS, 1 pt., 10 micron	
AB601C	3/4" NPS, 1 pt., 50 micron	
AA500C	1/2" NPS, 1 qt., 10 micron	
AA500E	1/2" NPS, 1 qt., 50 micron	
AA500G	3/4" NPS, 1 qt., 10 micron	
AA500J	3/4" NPS, 1 qt., 50 micron	
V400G	1/4" NPS, 8 oz., 50 micron	
V500D	3/4" NPS, 8 oz., 50 micron	
V400C	1/4" NPS, 8 oz., 50 micron	
FILTERS—metal jar		
AB608D	1/4" NPS, 1/2" pt., 10 micron	
AB612	1/2" NPS, 1/2" pt., 10 micron	
AB608B	3/4" NPS, 1/2" pt., 10 micron	
AB609	1/4" NPS, 1/2" pt., 50 micron	
AB608	3/4" NPS, 1/2" pt., 50 micron	
AB650C	3/4" NPS, 1 qt., 10 micron	
AB650G	3/4" NPS, 1 qt., 50 micron	
AB665	1/4" NPS, 1 qt., 50 micron	
AB665B	1/2" NPS, 1 qt., 10 micron	
FILTERS—plastic jar		
AA522N	1/4" NPS, 3/4" oz.	
V400H	1/4" NPS, 8 oz.	
V500N	3/4" NPS, 8 oz.	
FLUSHING SOLVENT		
AH255	1 qt.	
FOOT SUPPORT ASSEMBLIES		
AC136	0211, 0322, 0522	
AE240	1/4" 3/4" hp piston pumps	
AE241	1/2" 3/4" piston pumps	
AE245	1/4" hp piston pumps	

GAUGES—pressure		
AA842	1/4" NPS, 0-30 psi	
AA844B	1/4" NPS, 0-30 psi 0-25°Cm ²	
AA806	1/4" NPS, 0-150 psi (back mount)	
AA807	1/4" NPS, 0-100 psi (back mount)	
AF563	1/2" NPS, 0-100 psi, heavy duty (bottom mount)	
GAUGES—vacuum		
AA640	1/4" NPS, 0-30" Hg, 0-760 mm Hg	
AA641	1/2" NPS, 0-30" Hg	
HANDLES—carrying		
AF555	for 1/2" and 3/4" hp units	
MUFFLERS—glass jar		
AB699B	3/4" NPS, 1 pt., 10 micron, for oil-less pumps	
AB600C	1/4" NPS, 1 pt., 50 micron, for oil-less pumps	
AB600J	1/2" NPS, 1 pt., 50 micron, for oil-less pumps	
AD550	1" NPS, 2 qt., 50 micron	
AB608B	1" NPS, 2 qt., 50 micron, with fitting for quieter operation	
AA900F	3/4" NPS, 1 qt., 10 micron, for oil-less pumps	
AA900G	3/4" NPS, 1 qt., 50 micron, for oil-less pumps	
AA922B	1/4" NPS, 3/4" oz., 50 micron, for oil-less pumps same as AA922 but with silencing tube	
AA922G	1/4" NPS, 2 oz., 50 micron, for oil-less pumps	
AA617F	1/4" NPS, 2 oz., 50 micron, for oil-less pumps	
MUFFLERS—metal jar		
AB612A	1/2" NPS, 1/2" pt., 10 micron	
AB609B	1/4" NPS, 1/2" pt., 10 micron	
AB608A	3/4" NPS, 1/2" pt., 10 micron	
AB665C	1/2" NPS, 1 qt., 10 micron	
AB650D	3/4" NPS, 1 qt., 10 micron	
MUFFLERS—plastic jar		
AA922P	1/4" NPS, 3/4" oz.	
V425M	1/4" NPS, 8 oz.	
V525G	3/4" NPS, 8 oz.	
OVERLOADS—motor		
	External thermal protector, specify motor number and make	
PAINT		
AE554A	Cast blue-gray, 16 oz. aerosol can	
RELIEF VALVES—pressure		
AA223	1/4" NPS, flow below 2 cfm	
AA205	1/4" NPS, flow below 2 cfm	
AA500	3/4" NPS, flow below 10 cfm	
AA307	3/4" NPS, flow above 10 cfm	
AF570S	1/4" NPS, 0-100 psi	
AF730	1/4" NPT, 0-100 psi	
AE960	1" NPT, 0-100 psi	
RELIEF VALVES—vacuum		
AA204	1/4" NPS, flow below 2 cfm	
AA207	1/4" NPS, flow below 2 cfm	
AA840A	3/4" NPS, flow from 2-15 cfm	
AA308	3/4" NPS, flow above 10 cfm	
AE961	1" NPS, for 455S, 556S	
SWITCH—vacuum		
AE265	1/4" NPS	
TRAPS—vacuum		
AA673	3/4" NPS, 8 oz.	
AA675B	1/4" NPS, 2 oz.	
AA675C	1/4" NPS, 2 oz.	

TROUBLE SHOOTING GUIDE FOR ROTARY VANE PUMPS

REASONS FOR PROBLEM	Low		High		Pump Overheating	Motor Overload
	Vac.	Press.	Vac.	Press.		
Filter dirty	X	X	at pump		X	X
Muffler dirty		X		at pump	X	X
Vac. line collapsed	X		at pump		X	X
Relief valve set too high			X	X	X	X
Relief valve set too low	X	X				
Plugged vacuum or pressure line	X	X	at pump	at pump	X	X
Vanes sticking	X	X				
Running at too high RPM			X	X	X	X
Vanes worn (replace)	X	X				
Shaft seal worn (replace)	X	X				
Dust or offset powder in pump	X	X			X	X
Motor not wired correctly	X	X			X	

APPENDIX B

APPENDIX B
GEOLOGIC BORING LOGS AND
CHAIN-OF-CUSTODY FORMS

GEOLOGIC BORING LOG

JOB NUMBER: <u>DE268.23.04</u>	CLIENT: <u>AFCEE EDWARDS</u>	DATE: <u>1-7-93</u>
BORING NO.: <u>ED1-MPA</u>	BORING DIA.: <u>8.5"</u>	ELEV.: <u>~2000</u>
MACH. TYPE: <u>CME-75</u>	CONTRACTOR: <u>WEST HAZMAT DRILLING</u>	DATUM: <u>GROUND SURFACE</u>
TEMP (°F): <u>45</u>	WEATHER: <u>RAINING</u>	GEOLOGIST: <u>J.E.WALTERS</u>
	DRLNG MED: <u>NONE</u>	

Depth (ft.)	Pro-file	US CS	Geological Description	Samples		Sample Type	Drill Pres./ Blow Counts	Remarks
				No.	Depth (ft)			
0								
1		SW	VERY FINE TO MEDIUM SAND,					NO ODOR
2			sl MOIST, sm PEBBLES					NO DISCOLORATION
3								
4								
5			SAA					
6								
7		SW-	VERY FINE TO MEDIUM, MEDIUM					
8		SM	BROWN SAND w sm SILT					PID=0.0/29.3 *
9				ED1-MPA-	9.5-11	S	46,50	TD @ 9.5' AUGER
10				9.5			38,50	
11								
12								
13								
14								
15								

w - with	sl - slight	S	SPLIT SPOON SAMPLE
sm - some	v - very	G	GRAB SAMPLE
tr - trace	SAA - Same As Above	U	UNDISTURBED SAMPLE
* - from field log book			

GEOLOGIC BORING LOG

JOB NUMBER: DE268.23.04	CLIENT: AFCEE EDWARDS	DATE: 1-8-93
BORING NO.: ED1-MPB	BORING DIA.: 8.5"	ELEV: ~2000
MACH. TYPE: CME-75	CONTRACTOR: WEST HAZMAT DRILLING	DATUM: GROUND SURFACE
TEMP (°F): 40	WEATHER: CLEAR WINDY	GEOLOGIST: J.E.WALTERS
	DRLNG MED: NONE	

Depth (ft.)	Pro-file	US CS	Geological Description	Samples		Sample Type	Drill Pres./ Blow Counts	Remarks
				No.	Depth (ft)			
0								
1		SW-	VERY FINE TO COARSE LIGHT					PID CUTTINGS=0.0/0.0
2		SM	BROWN SILTY SAND, MOIST					
3								
4								
5		SAA						PID CUTTINGS=0.0/0.0
6								
7								
8								IN WIND
9			SAA w sm SILT AND SMALL PEBBLES	ED1-MPB-9.5	9.5-11	S	59,69,79	PID IN SAMPLE=0.0/0.0 HIGH WIND - PID 0.0/120 * TD @ 9.5' AUGER
10								
11								
12								
13								
14								
15								

w - with

sl - slight

S

SPLIT SPOON SAMPLE

sm - some

v - very

G

GRAB SAMPLE

tr - trace

SAA - Same As Above

U

UNDISTURBED SAMPLE

* - from field log book

GEOLOGIC BORING LOG

JOB NUMBER: <u>DE268.23.04</u>	CLIENT: <u>AFCEE EDWARDS</u>	DATE: <u>1-8-93</u>
BORING NO.: <u>ED1-MPC</u>	BORING DIA.: <u>8.5"</u>	ELEV.: <u>~ 2000</u>
MACH. TYPE: <u>CME-75</u>	CONTRACTOR: <u>WEST HAZMAT DRILLING</u>	DATUM: <u>GROUND SURFACE</u>
TEMP (°F): <u>50</u>	WEATHER: <u>CLEAR WINDY</u>	GEOLOGIST: <u>J.E.WALTERS</u>
	DRLNG MED: <u>NONE</u>	

Depth (ft.)	Pro-file	US CS	Geological Description	Samples		Sample Type	Drill Pres./ Blow Counts	Remarks
				No.	Depth (ft)			
0								
1		SW	VERY FINE TO MEDIUM LIGHT					
2			BROWN SAND, WELL SORTED,					PID @ 2-3'=0.0/0.0
3			POSSIBLY FILL					
4								
5		SW -	SAA w SILT					
6		SM						sl ODOR, sl DISCOLORATION
7								PID=0.0/0.0
8								
9		SAA		ED1-MPC-9.5	9.5-11	S		
10								PID=0.0/0.0
11								TD @ 10.5' (BORING)
12								
13								PID CUTTINGS=318 *
14								
15								

w - with	sl - slight	S	SPLIT SPOON SAMPLE
sm - some	v - very	G	GRAB SAMPLE
tr - trace	SAA - Same As Above	U	UNDISTURBED SAMPLE
* - from field log book			

GEOLOGIC BORING LOG

JOB NUMBER: <u>DE268.23.04</u>	CLIENT: <u>AFCEE EDWARDS</u>	DATE: <u>1-9-93</u>
BORING NO.: <u>ED2-MP1</u>	BORING DIA.: <u>8.5"</u>	ELEV: <u>~2000</u>
MACH. TYPE: <u>CME-75</u>	CONTRACTOR: <u>WEST HAZMAT DRILLING</u>	DATUM: <u>GROUND SURFACE</u>
TEMP (°F): <u>50</u>	WEATHER: <u>SUNNY, WINDY, COOL</u>	GEOLOGIST: <u>J.E.WALTERS</u>
	DRLNG MED: <u>NONE</u>	

Depth (ft.)	Pro-file	US CS	Geological Description	Samples		Sample Type	Drill Pres./ Blow Counts	Remarks
				No.	Depth (ft)			
0								
1		SW-	MEDIUM BROWN, FINE TO COARSE					PID CUTTINGS=0.0/0.0
2		SM	SILTY SAND, MOIST, sm PEBBLES					
3								
4								
5								
6								
7		CL	GREEN-BROWN SANDY CLAY					
8								
9								
10		SW-	DARK GREY, MEDIUM TO VERY					PID=0.0/20.0 *
11		SM	COARSE SAND, MOIST sm PEBBLES	ED2-MP1-11.5		S	18,22,31	PETROLEUM ODOR * GREY DISCOLORATION *
12								PID=0.0/4.3 *
13								TD @ 12.0'
14								
15								

w - with	sl - slight	S	SPLIT SPOON SAMPLE
sm - some	v - very	G	GRAB SAMPLE
tr - trace	SAA - Same As Above	U	UNDISTURBED SAMPLE
* - from field log book			