

Serial No.: 09/635,227

Filing Date: 09 August 2000

Inventor: Gregg A. Johnson

NOTICE

The above identified patent application is available for licensing.
Requests for information should be addressed to:

ASSOCIATE COUNSEL (PATENTS)
CODE 1008.2
NAVAL RESEARCH LABORATORY
WASHINGTON DC 20375

DISTRIBUTION STATEMENT A
Approved for Public Release
Distribution Unlimited

DTIC QUALITY INSPECTED 4

20001113 081

PATENT APPLICATION/TECHNICAL DIGEST PUBLICATION RELEASE REQUEST

FROM: Associate Counsel (Patents) (1008.2)
TO: Associate Counsel (Patents) (1008.2)

Via: (1) Gregg Johnson (Code 5673)
(2) Division Superintendent (Code 5600)
(3) Head, Classification Management & Control (Code 1221)

SUBJ: Patent Application/Technical Digest entitled: **"PASSIVE, TEMPERATURE COMPENSATED TECHNIQUES FOR TUNABLE FILTER CALIBRATION IN BRAGG GRATING INTERROGATION SYSTEMS"** Request for release for publication.

REF: (a) NRL Instruction 5510.40C
(b) Chapter 6, ONRINST 5870.1C

ENCL: (1) Copy of Patent Application/Technical Digest

1. In accordance with the provision of references (a) and (b), it is hereby requested that the subject Patent Application/Technical Digest be released for publication.

2. It is intended to offer this Patent Application/Technical Digest to the National Technical Information Service, for publication.

3. This request is in connection with Navy Case No. 82,373

8/14/00
(date)



BARRY A. EDELBERG
Associate Counsel (Patents)

FIRST ENDORSEMENT

Date: 8/18/00

FROM: Gregg Johnson (Code 5673)
TO: Division Superintendent (Code 5600)

1. It is the opinion of the Inventor(s) that the subject Patent Application/Technical Digest (~~is~~) (is not) classified and there is no objection to public release.



Inventor's Signature

SECOND ENDORSEMENT

Date: 23 August 2000

FROM: Division Superintendent (Code 5600)
TO: Classification Management & Control (Code 1221)

1. Release of Patent Application/Technical Digest (is) (~~is not~~) approved.
2. To the best knowledge of this Division, the subject matter of this Patent Application/Technical Digest (~~has~~) (has not) been classified.
3. This recommendation takes into account military security, sponsor requirements and other administration considerations and there in no objection to public release.

Dr. C. Hoffman, Acting Supt., OSD, Code 5600

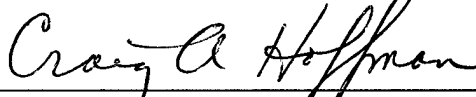

Division Superintendent

THIRD ENDORSEMENT

Date:

FROM: Head, Classification & Control (Code 1221)
TO: Associate Counsel (Patents) (1008.2)

1. This Patent Application/Technical Digest is authorized for public release.



Head, Classification, Management & Control

Inventors: Johnson et al.
Serial No.

PATENT APPLICATION
Navy Case No. 82,373

5

PASSIVE, TEMPERATURE COMPENSATED TECHNIQUES
FOR TUNABLE FILTER CALIBRATION IN BRAGG-GRATING
INTERROGATION SYSTEMS

10

BACKGROUND OF THE INVENTION

Field of the Invention

15

Generally this invention pertains to a wavelength reference and calibration device, and more specifically to a fiber Bragg grating interrogation system for determination of Bragg grating wavelengths.

Description of the Related Art

20

There is a need for accurate measurement of Bragg gratings wavelengths that includes long-term and static strain monitoring on structures and determination of wavelengths in optical communications systems. There a number of systems that use the wavelength of fiber Bragg gratings to indicate the value of a measurand such as strain or temperature often at distributed points on a structure. In systems of multiple Bragg gratings -- especially in a single fiber --

25

bandpass filters that scan through a range of wavelengths are commonly employed. (SEE, Kersey et al.; A MULTIPLEXED FIBER BRAGG STRAIN SENSOR SYSTEM WITH A FIBER FABRY-PEROT WAVELENGTH FILTER; Optics Lett., Vol/18, Pg. 1370, 1993.) In some schemes, the control signal applied to the filter is used to determine the wavelength of the individual gratings. This practice depends on an estimated functional relationship between the

Inventors: Johnson et al.
Serial No.

PATENT APPLICATION
Navy Case No. 82,373

5 filter control input and the wavelength location of the passband, a function that is not in practice linear or constant in time. For dynamic measurements a one-time calibration is often adequate, while for very low frequency measurements a real-time calibration is necessary for accurate determination of Bragg grating wavelength. Current filter calibration options include wavelength references such as temperature-isolated gratings (**SEE**, U.S. Patent No. 5,818,585) or the fringe
10 pattern of a temperature-isolated Fabry-Perot cavity (**SEE**, U.S. Patent No. 5,892,582). In either case, the reference wavelengths are sensitive to changes in temperature and care must be taken to keep the gratings or cavity at a constant temperature.

SUMMARY OF THE INVENTION

15 The object of this invention is to provide an interrogation system for fiber Bragg gratings enabling accurate determination of Bragg grating wavelengths that is compensated for changes in temperature, if required.

This and other objectives are met by a passive, temperature compensated tunable filter calibration device for Bragg grating interrogation having a set of reference wavelengths, enabling
20 accurate determination of Bragg grating wavelengths. There are two devices, first is a system that estimates the temperature of an array of gratings using an array of gratings bonded to a common host substrate and a single grating bonded to a material with different linear coefficient of thermal expansion, this is called a dual-substrate Bragg grating calibration system. Changes in a common temperature of the substrates is measured by monitoring the difference between

5 shifts of grating wavelength. As a filter is scanned from its lowest to highest voltage and the
voltages are recorded. The second lowest wavelength corresponds to the grating attached to the
differing substrate. The voltages are used to calculate the voltage-to-wavelength function for the
scanning range of the filter. To compensate for variations in a calibration curve and temperature
variations of the calibration array, the temperature is estimated and function recalculated at every
10 pass of the scanning filter.

The second system uses a wavelength reference absorption cell, preferably a hydrogen-
cyanide ($H^{14}C^{13}N$) type of wavelength reference absorption cell, that absorbs light at discrete
wavelengths corresponding to the molecular vibrational mode frequencies of the gas. A
wavelength reference absorption cell utilizing acetylene may be used, however the hydrogen-
15 cyanide cell has more lines across a bigger range. With a broadband input to the cell, the output
displays the spectrum of the input with several narrow dips in the spectrum corresponding to the
absorption lines. A photodetector sees the transmission spectrum of the absorption cell while
another photodetector sees the Bragg gratings reflection from a sensing array. The filter drive
voltages that coincide with the dips of the transmission spectrum are used to calibrate the
20 voltage-to-wavelength function of the scanning filter. In this system, there is no temperature
compensation step as the absorption lines are not sensitive to temperature.

BRIEF DESCRIPTION OF THE DRAWINGS

Figure 1a shows a block diagram of a passive, temperature compensated device for a
25 tunable filter calibration Bragg-grating utilizing a dual-substrate Bragg grating calibration

5 system.

Figure 1b shows a functional relationship between control voltage and passband center wavelength.

Figure 1c shows the voltage peaks present in the amplifiers indicating Bragg gratings at different scanning voltage values.

10 **Figure 1d** shows passband wavelength (nm) as constructed from the filter control voltage at known wavelengths of Bragg gratings on a glass and aluminum substrate.

Figure 2a shows a block diagram of a Bragg grating interrogation system for a tunable filter calibration utilizing a hydrogen-cyanide wavelength reference absorption cell.

Figure 2b shows a normalized transmission spectrum.

15 **Figure 2c** shows a series of dips in voltage on amplifier A indicating absorption lines at different scanning voltage values (V_1 to V_n)(different passband wavelengths) and peaks in voltage (V_{FBG1} and V_{FBG2}) on amplifier B corresponding to gratings at two different wavelengths.

DESCRIPTION OF THE PREFERRED EMBODIMENT

20

The first preferred embodiment of a passive, temperature compensated device for a tunable filter calibration Bragg-grating 10, as shown in **Figure 1**, is an array 12 of at least six Bragg gratings 14, five Bragg gratings 14 are bonded to a common host substrate 16, α_1 , such as glass, with a single grating 18 bonded to a substrate 22, α_2 , material, with a different linear coefficient of

5 thermal expansion, such as aluminum (α representing the coefficient of expansion). The gratings
16 and 22 are reference gratings 21. The Bragg wavelength, λ_B , of an unbonded grating will
vary with temperature due to changes in the index of refraction of a fiber core, d_n , and the
expansion/contraction of the glass fiber itself according to

10
$$\Delta\lambda_B = [(d\Lambda/dT)/\Lambda + (dn/dT)/n]\lambda_B\Delta T \quad (1)$$

where Λ is the period of the index-modulation of the fiber core, which creates the grating. The
($d\Lambda/dT)/\Lambda$ term is simply the thermal coefficient of linear expansion. For silica the dn/dT term
dominates the thermal wavelength shift effect. When bonded to a substrate 16 or 22, the changes
15 in length due to temperature can be amplified, where ($d\Lambda/dT)/\Lambda$ is replaced by the expansion
coefficient of the substrate which can be much higher. By bonding two gratings 12 and 18 to two
different substrates 16 and 22 with differing expansion coefficients, changes in the common
temperature of the substrates 16 and 22 can be measured by monitoring the difference between
shifts of the grating wavelengths according to

20
$$\Delta T = (\Delta\lambda_{B1} - \Delta\lambda_{B2}) / \left\{ \lambda_{B1}[\alpha_1 + (dn/dT)/n] - \lambda_{B2}[\alpha_2 + (dn/dT)/n] \right\} \quad (2)$$

when it is assumed that the coefficients of the substrates, α_1 and α_2 , are well known, and the
Bragg wavelengths are known prior to the change in temperature.

Equation (2) is used first to estimate the temperature of an array of the gratings 12 with

5 the estimated temperature, the present wavelengths of the gratings 14 being estimated from

$$\lambda_{Bi} = \lambda_{Bi}|_{T=T_0} + \lambda_{Bi}[\alpha_i + (dn/dT)/n](T - T_0) \quad (3)$$

where T_0 is the temperature at which λ_{Bi} is initially measured, and i refers to the grating number.

Wavelength-shift detection systems use scanning bandpass filters to measure grating
10 wavelengths according to the control voltage applied to the filter at the same time the grating
wavelength and passband wavelength coincide. The relationship between control voltage and
passband center wavelength is typically nonlinear. For example, a scanning Fabry-Perot filter is
often used in these applications. **Figure 1b** illustrates the functional relationship between control
voltage and passband center wavelength. Furthermore, the function often encounters a drift over
15 even short time periods such that after several minutes the curve may shift from the solid line 24
to the dotted line 26. In this case, a continuously updated calibration curve is necessary to ensure
an accurate wavelength-to-voltage mapping that is needed for wavelength- shift accuracy as well
as low frequency, absolute wavelength monitoring.

The scanning filter 28 filters a broadband source of optical light 32 generated by an
20 optical light source 76 so that at any point in time only a narrow band of light is present in the
grating-containing fibers 32 that are connected to the output of the filter 28 through 50/50
couplers 34. In this embodiment light is only returned to photodetectors A 36 and B 78 when the
passband is scanned through the wavelength of a grating 14 or 18, and the gratings 14 and 18
reflects back through the coupler 34 to the detector 38 then amplified in an associated amplifier

5 42. The amplified photodetector signal 37 results in a series of peaks that correspond to the gratings 14 or 18 in the arrays 12 and 22 from the lowest wavelength to highest as the drive voltage 44, $V(t)$, is increased. In this embodiment 10, one grating array 12 contains the calibration and reference device 16 and 22, while the other array 98 is considered an array of sensing gratings 102 and 104. The sensing grating, for example, may be bonded to a bridge
10 girder. To know the Bragg wavelength of these gratings it is necessary for the calibration/reference device have a high accuracy.

The following steps are used in the first preferred embodiment 10 to determine the reference wavelengths and the scanning filter calibration curve and finally the wavelengths of the sensing Bragg gratings 102 and 104. As the filter voltage 44 is scanned from its lowest to
15 highest voltage, the voltages at which the reference gratings 21 are encountered, V_1 52 - V_2 54 are recorded, as shown in Figure 1c. V_7 46 and V_8 48 denote the voltages at which the sensing gratings 102 and 104 are encountered. The 2nd lowest wavelength, λ_2 , corresponds to the grating 18 which is attached to a substrate 22 different from the rest of the reference grating 14. In this example this grating 18 is bonded to an aluminum strip while the other gratings 14 are bonded to
20 a glass slide. When the temperature of the substrates 16 and 22 change together (they are in thermal contact) the aluminum-bonded grating 18 sees more expansion and compression than the glass-bonded gratings 14, Correspondingly, the ratio

$$R = (V_2 - V_1)/(V_3 - V_1) \quad (4)$$

5 increases as temperature T increases. If the lowest three Bragg wavelength, λ_1 52 through λ_3 56 are chosen to be within a few nanometers of each other, as shown in **Figure 1d**, R is well approximated to be linear and is independent of the peak-to-peak amplitude of the filter drive voltage 44. R is typically measured directly by placing the reference device 14 and 18 in an environmental chamber and recording R as T is varied through a wide range. With this
10 calibration curve, T can be approximated by calculation of R with every sweep of the filter 48. Once T is acquired the glass-bonded and aluminum-bonded gratings 14 and 18, respectively, wavelengths are calculated from Equation (3) to obtain λ_1 through λ_6 . At this point the voltages V_1 52 through V_6 64 are used with the λ 's to calculate the voltage-to-wavelength function for the scanning range of the filter 28. For scanning Fabry-Perot filters 28, the function is well
15 approximated by a 3rd order polynomial. With the function estimated, the wavelength of the sensor gratings λ_7 102 and λ_8 104 in **Figure 1a**, are calculated from the voltages V_7 46 and V_8 48. To compensate for variations in the calibration curve and temperature variations of the calibration array, the temperature is estimated and the function recalculated at every pass of the scanning filter 28 by the associated processing electronics 39.

20 In a second preferred embodiment 20, as shown in **Figure 2a**, a hydrogen-cyanide ($H^{14}C^{13}N$) wavelength reference absorption cell 66 is used. The gas is held in a pressurized cylinder with a fiber optic input 68 and output 72. The cell 66 absorbs light at discrete wavelengths corresponding to the molecular vibrational mode frequencies of the gas. With a broadband optical light 74, from a broadband optical light source 78, input to the cell 66 in the

5 range of 1525 to 1565 nm wavelengths, the output 72 displays the spectrum of the input 68 with several narrow dips in the spectra corresponding to the absorption lines. The normalized transmission spectrum is shown in **Figure 2b**. Twenty-one of the lines have a center wavelength uncertainty of less than +/- 0.0006 nm. Extreme variations in temperature (+/- 100K) only shift the wavelengths by 8.0×10^{-6} nm, hence for most applications, the lines may be assumed to be
10 stationary with changes in temperature, The gas cells 66 are commercially available from such source as a HCN Optical Cell manufactured by Technical Glass, Inc. of Aurora, CO, and are fiber-pigtailed by the vendor.

To use the absorption cell 66 as a wavelength reference and filter calibration tool in fiber Bragg grating applications, photodetector A 36 sees a transmission spectrum of the absorption
15 cell 66 while photodetector B 78 sees the Bragg grating reflections from the sensing array 82. Similar to the teachings of the first preferred embodiment 10, the filter drive voltages V_1 82 through V_n 122, as shown in **Figure 2c**, that coincide with the location of dips in the transmission spectrum (at known wavelengths) are used to calibrate the voltage-to-wavelength function of the scanning filter 28. As opposed to the dual-substrate Bragg grating calibration
20 taught in the first preferred embodiment 10, this embodiment 20 has no temperature compensation step because the absorption lines are not temperature sensitive. The sensing grating 82 wavelengths are estimated from the voltages at their peak values, V_{FBG1} 124 and V_{FBG2} 126, as shown in **Figure 2c**, and the calibration function.

Both embodiments 10 and 20, may be applied to tunable filters other than the fiber Fabry-

Inventors: Johnson et al.
Serial No.

PATENT APPLICATION
Navy Case No. 82,373

5 Perot filters taught herein. Additionally, the placement of the filter **28** and sensing array **82** may vary in their placement in the optical system, for example the sensing array **82** may be placed in series with the gas cell **66** or dual-substrate grating array **16** and **22**.

Although the invention has been described in relation to an exemplary embodiment thereof, it will be understood by those skilled in the art that still other variations and
10 modifications can be affected in the preferred embodiment without detracting from the scope and spirit of the invention as described in the claims.

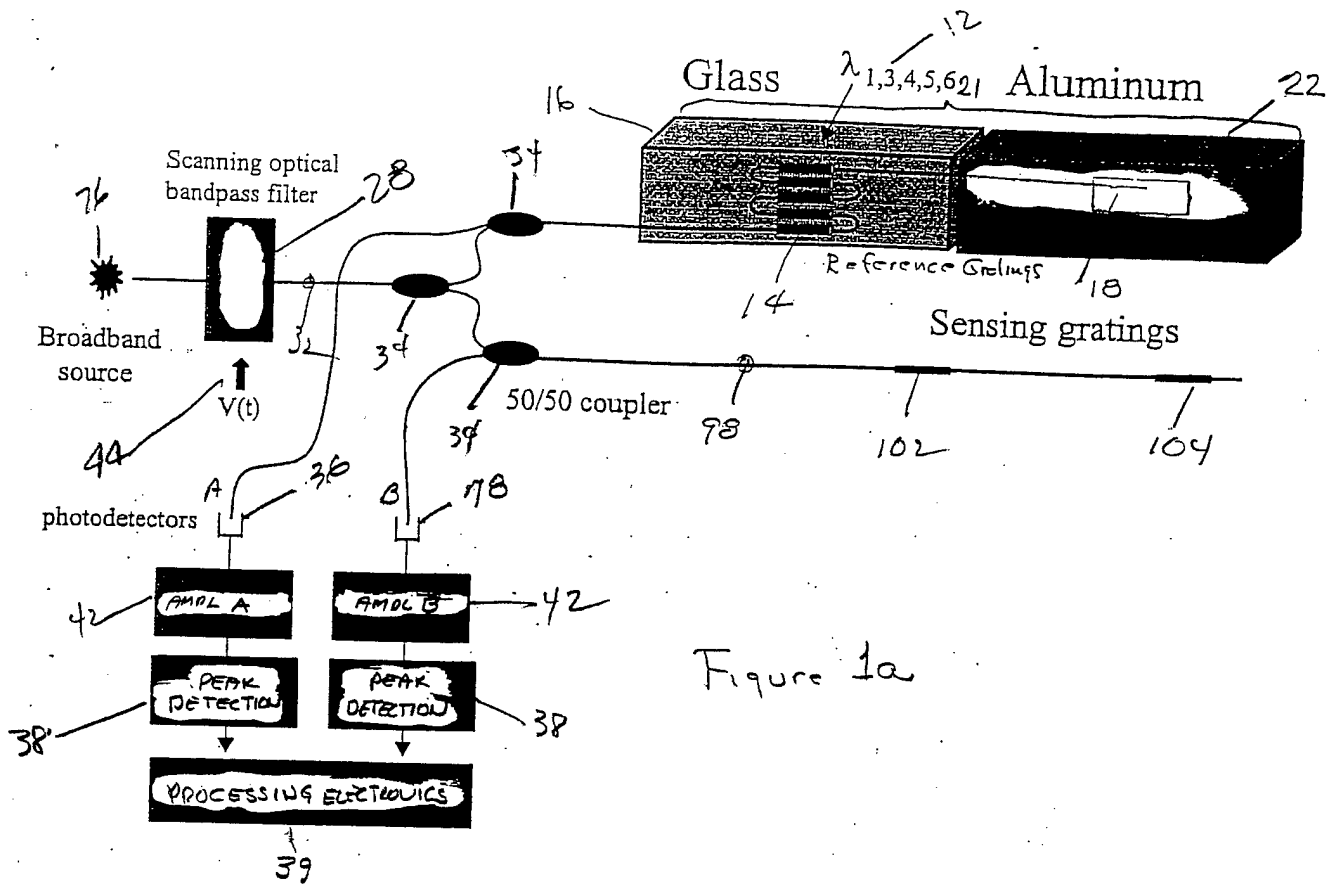

Figure 1a

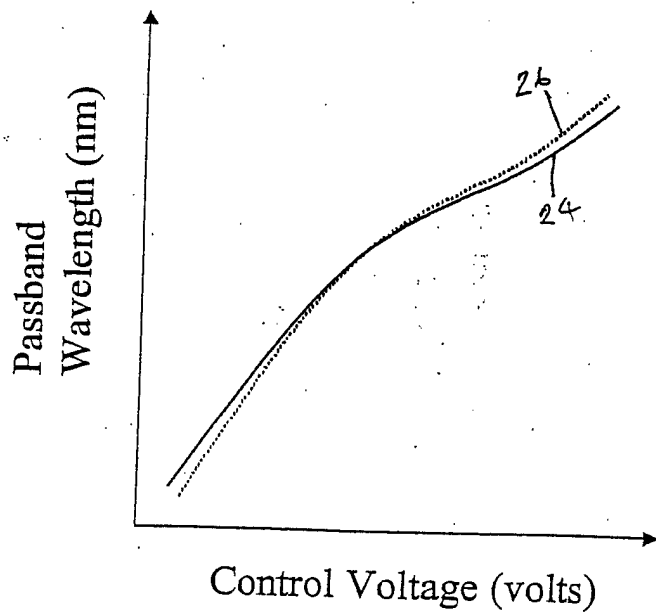

Figure 1b

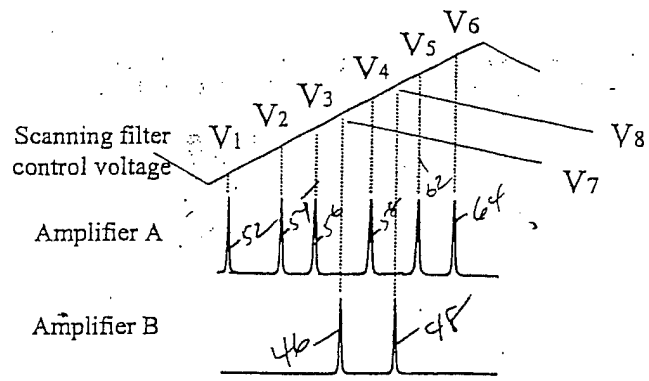

Figure 1c

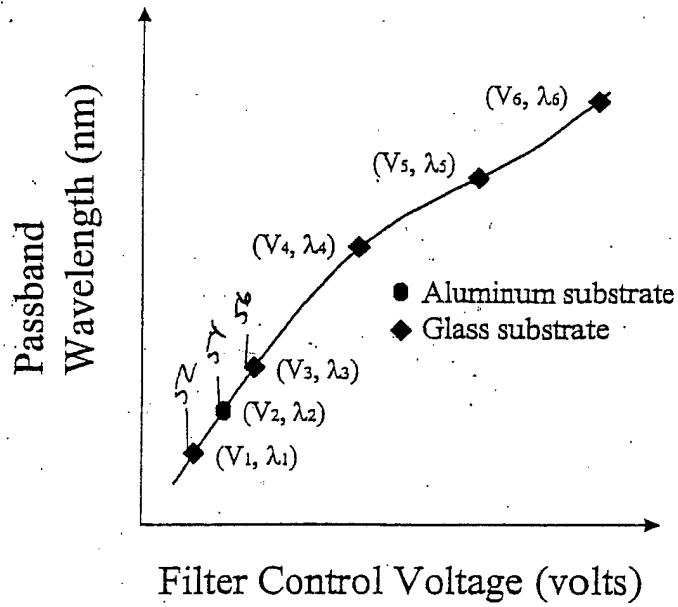
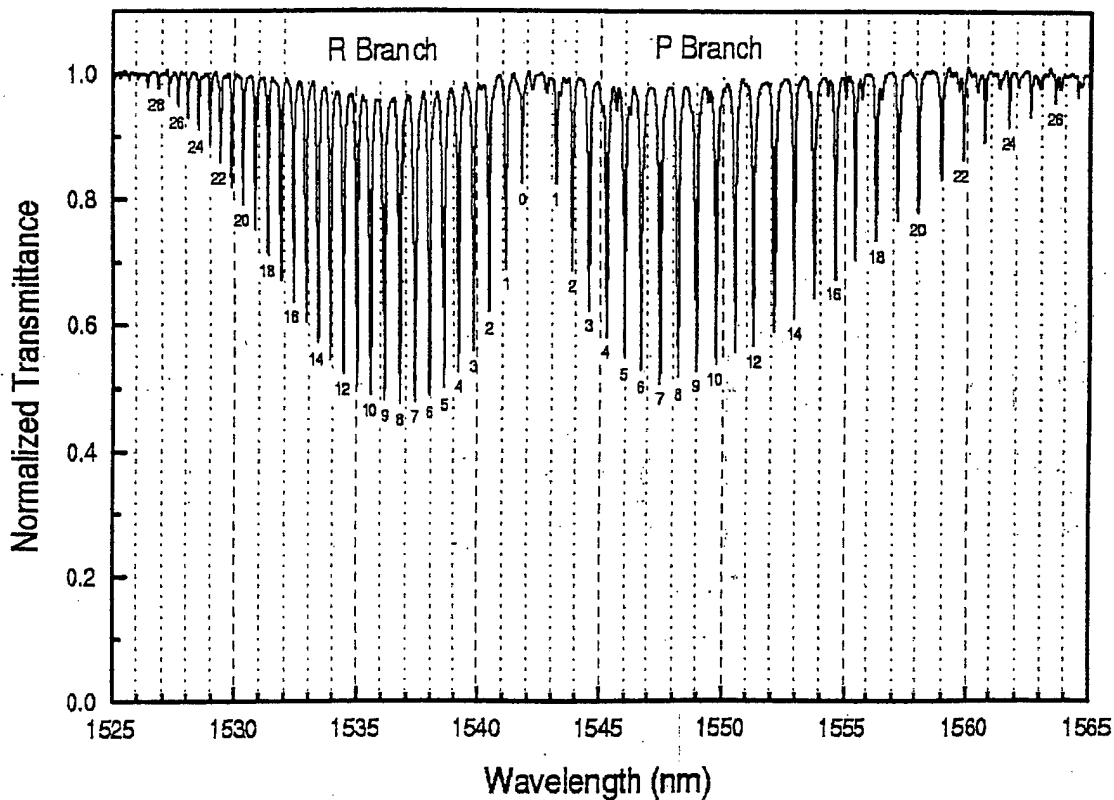
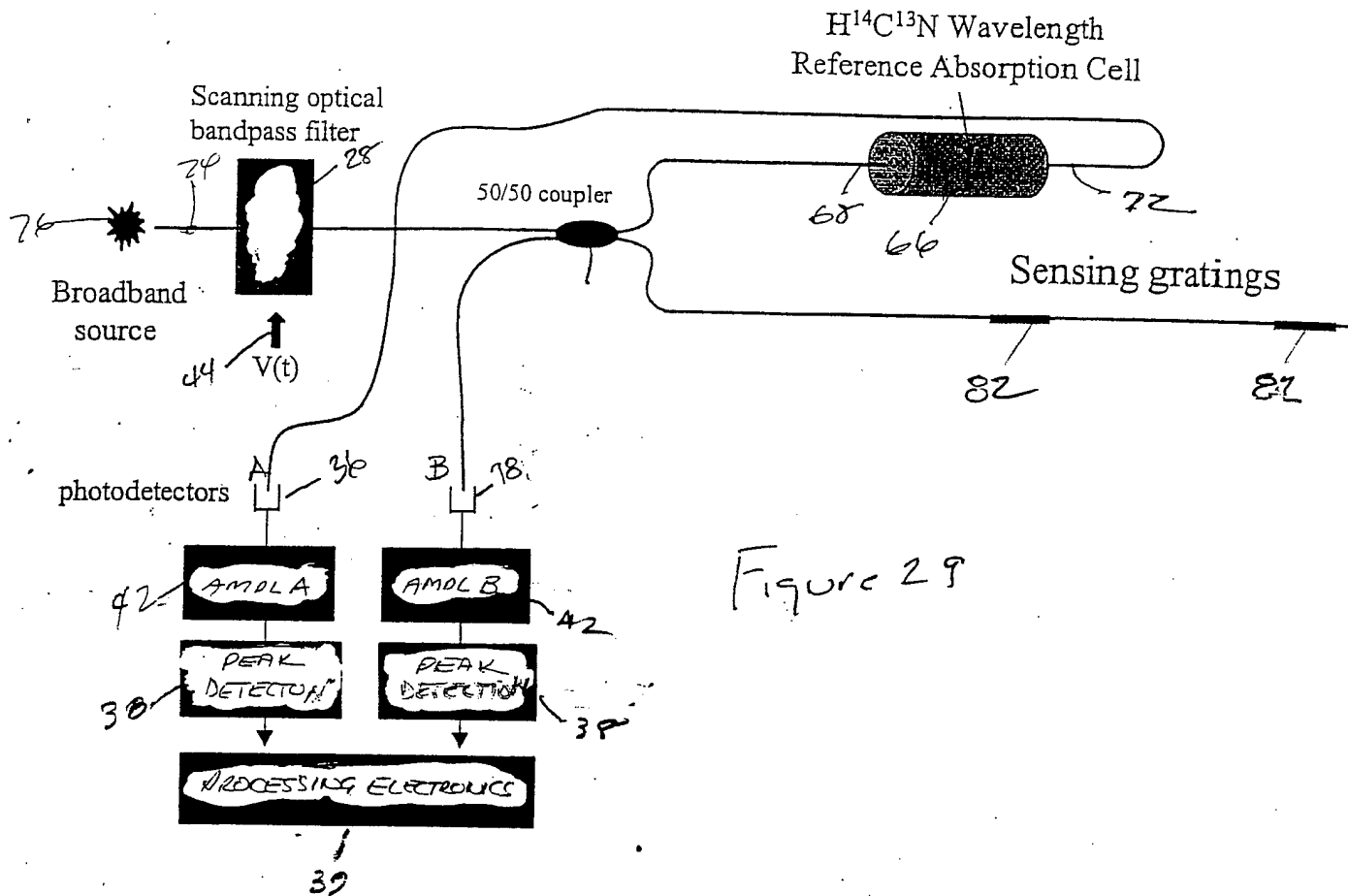

Figure 1d



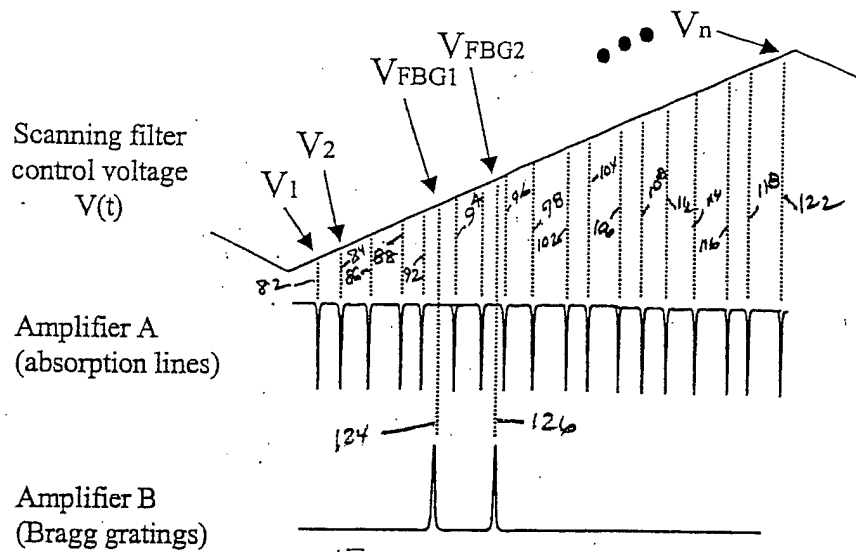

Figure 2c