

ERDC TR-00-7

Engineer Research and
Development Center



US Army Corps
of Engineers®

Olmsted Wicket Blank Experiment in 1:5-Scale Hydraulic Flume Model

Mostafiz R. Chowdhury and W. Glenn Davis

September 2000

Approved for public release; distribution is unlimited.

20001127 046

DTIC QUALITY INSPECTED 4

The contents of this report are not to be used for advertising, publication, or promotional purposes. Citation of trade names does not constitute an official endorsement or approval of the use of such commercial products.

The findings of this report are not to be construed as an official Department of the Army position, unless so designated by other authorized documents.



PRINTED ON RECYCLED PAPER

ERDC TR-00-7
September 2000

Olmsted Wicket Blank Experiment in 1:5-Scale Hydraulic Flume Model

by **Mostafiz R. Chowdhury**
Structures Laboratory
U.S. Army Engineer Research and Development Center
3909 Halls Ferry Road
Vicksburg, MS 39180-6199

W. Glenn Davis
Coastal and Hydraulics Laboratory
U.S. Army Engineer Research and Development Center
3909 Halls Ferry Road
Vicksburg, MS 39180-6199

Final report

Approved for public release; distribution is unlimited

Prepared for **U.S. Army Corps of Engineers**
Washington, DC 20314-1000
and **U.S. Army Engineer District, Louisville**
Louisville, KY 40201-0059

Engineer Research and Development Center Cataloging-in-Publication Data

Chowdhury, Mostafiz R.

Olmsted Wicket Blank Experiment in 1:5-scale hydraulic flume model / by Mostafiz R. Chowdhury, W. Glenn Davis ; prepared for U.S. Army Corps of Engineers and U.S. Army Engineer District, Louisville.

73 p. : ill. ; 28 cm. -- (ERDC ; TR-00-7)

Includes bibliographic references.

1. Hydraulic gates -- Ohio River. 2. Hydraulic models -- Ohio River. 3. Olmsted Locks and Dam Project. I. Davis, W. G. II. United States. Army. Corps of Engineers. III. United States. Army. Corps of Engineers. Louisville District. IV. Engineer Research and Development Center (U.S.) V. Structures Laboratory (U.S.) VI. Coastal and Hydraulics Laboratory (U.S.) VII. Title. VIII. Series: ERDC TR ; 00-7.

TA7 E8 no.ERDC TR-00-7

Contents

Preface.....	iv
Conversion Factors, Non-SI to SI Units of Measurement.....	v
1—Introduction	1
Background	1
Objectives.....	2
Blank Model Descriptions.....	2
Scope.....	3
2—Instrumentation, Data Acquisition, and Analysis.....	5
Instrumentation	5
Data Acquisition and Analysis.....	5
3—Results and Discussions	8
Introduction	8
General Observations	8
Actuator-Connected Experiments	8
Blank Experiment Results.....	10
Data Analyses and Discussions.....	12
Point-Load Results	13
4—Observations and Conclusions	18
Figures 1-63	
Appendix A: Shop Drawings	A1
SF 298	

List of Tables

Table 1. General Outline of Experimental Results for the Actuator-Connected Blank Wicket.....	9
Table 2. General Layout of Blank Gate Experimental Results	11
Table 3. Maximum Response Table for the Blank Gate Experiments.....	14
Table 4. Point-Load Experimental Results for the Blank Gate Operation	15

Preface

The research reported herein was sponsored by the U.S. Army Engineer District (USAED), Louisville, in support of the Olmsted Navigational Model Study Program. Mr. Rick Schultz, USAED, Louisville, was the Program Monitor for the physical model studies.

All work was carried out by Dr. Mostafiz R. Chowdhury, Structural Mechanics Division (SMD), Structures Laboratory (SL), U.S. Army Engineer Research and Development Center (ERDC), under the general supervision of Dr. Michael J. O'Connor, Acting Director, SL; Dr. Reed Mosher, Chief, SMD; Dr. Robert L. Hall, Chief, Structural Analysis Group; and Mr. Winston Glenn Davis, Spillways and Channels Branch, Coastal and Hydraulics Laboratory (CHL), ERDC, under the general supervision of Dr. James Houston, Director, CHL; Mr. Tom Richardson, Assistant Director, CHL; Dr. Phil Combs, Chief, Rivers and Structures Division; and Mr. James R. Leech, Chief, Spillways and Channels Branch. The work was conducted during May 1999 through May 2000 under the direct supervision of Dr. Chowdhury and Mr. Davis.

Mr. Ken Vitaya-udom, SL, prepared the model shop drawings. Mr. Bill W. Tennant, Welding Shop, and Mr. Robert D. Parman, Machine Shop, are credited for fabrication of the blank gate. Mr. Wallace S. Guy, Information Technology Laboratory (ITL), ERDC, was responsible for instrumentation, and Mr. David Mobley (CHL) was responsible for operation of the model during experiments. Mr. Terry W. Warren, ITL, wrote the program for data acquisition, and Mr. Homer C. Greer, ITL, was responsible for coordinating instrumentation and data acquisition tasks.

At the time of publication of this report, the Director of ERDC was Dr. James R. Houston, and Commander was COL James S. Weller, EN.

The contents of this report are not to be used for advertising, publication, or promotional purposes. Citation of trade names does not constitute an official endorsement or approval of the use of such commercial products.

Conversion Factors, Non-SI to SI Units of Measurement

Non-SI units of measurement used in this report can be converted to SI units as follows:

Multiply	By	To Obtain
cubic feet	0.02831685	cubic metres
cubic inches	0.000016387	cubic metres
degrees (angle)	0.01745329	radians
Fahrenheit degrees	5/9	Celsius degrees ¹
feet	0.3048	metres
G (standard acceleration of free fall)	9.80665	metres per second squared
inches	0.0254	metres
ksi (kips per square inch)	6.894757	megapascals
kips	4.4484	kilonewtons
pounds (force)	4.4484	newtons
pounds (mass)	0.4535924	kilograms
pounds (force) per square inch	0.006894757	megapascals
tons	1,000	kilograms

¹ To obtain Celsius (C) temperature readings from Fahrenheit (F) readings, use the equation:
 $C = (5/9) - (F - 32)$.

1 Introduction

Background

The U.S. Army Engineering Research and Development Center (ERDC) has conducted research to determine the adequacy and constructibility of the current horse-style wicket gate design and to evaluate the operability of the proposed wicket blank¹. A series of 1:5-scale wicket blank model experiments were conducted at the existing 1:5 model facility in ERDC. The experimental data presented in this document support the design development of the prototype wicket blank for the Olmsted Dam.

The proposed Olmsted Dam will replace two existing Locks and Dams on the lower Ohio River (Locks & Dam No. 52 and 53). The new dam will consist of twin 1,200-ft-long by 110-ft-wide navigation locks, five tainter gate bays, and approximately a 1,400-ft-wide navigable pass. The navigable pass portion of the dam will use wicket gates to facilitate the barge/tow traffic approximately 60 percent of a given year. During low-flow periods, the wicket gates will be raised to provide navigable depths upstream of the dam. The wicket gates will be manually raised and lowered from a workboat. The possibility exists that during the operation of raising the dam, a single wicket may not be able to be raised, thus leaving a hole or gap in the dam. The wicket blank was designed to temporarily fill the gap left from an inoperable gate.

The 1:5-scale wicket blank was constructed and tested in the existing 1:5-scale hydraulic model. The suggested overall width of the wicket blank was 10 ft, 11 in. The wicket blank was geometrically scaled and fabricated in accordance to the design drawings previously furnished to ERDC. The 1:5 scale-model facility with 12 hydraulically operated wicket gates was modified to simulate gate widths of 9 ft, 8 in. and gate heights to elevation (el)² 302 in the operating or raised position. The existing instrumented wicket gate presently installed in the model facility was used to determine the forces exerted on wicket gates during wicket blank installation. Additional instrumentation was added to measure the forces required to get the blank in place and the loads transferred to the wicket at various heads. The experimental results for blank installation, removal, and in-place operations are presented in this document.

¹ Memorandum from the office of the U.S. Army Engineer District (USAED), Louisville (CELRL-ED-TH), 30 April 1999, subject: Olmsted L&D 1:5 Model Testing.

² Elevations cited herein are in feet and referred to the Ohio River Datum.

Objectives

The objective of the 1:5-scale wicket blank experiments was to simulate the functional behavior of the wicket blank during its operation in the Olmsted Dam. The simulated experiments were conducted to identify operational difficulties, determine loads during blank installation and removal, and to evaluate the overall performance of the wicket blank for various operational configurations.

Blank Model Descriptions

The wicket blank experiments were conducted in the model facility to evaluate the overall operability of the wicket blank. The model wicket blank was fabricated such that the material, material thickness, size, and weight of the prototype wicket blank were simulated in the model.

Figure 1 shows the blank model operation in the dry 1:5 model facility. Typically during the installation process, the upright blank will ride over the adjacent gates as shown in Figure 1. A winch cable is used to lower the blank until it reaches its seated position, which is el 279 in the model. It should be noted that because of differences between the hydraulically operated wicket design simulated in the model and the new horse-wicket design, the blank could not be lowered to its proposed seated depth at el 275.85 during model operations. The effect of this discrepancy in the model and prototype base elevations must be accounted for when estimating prototype responses using the model data presented in this report. When the blank reaches the seated position (see Figures 2 and 3), the actuator force is released such that the flow induced load tilts the blank about the dam axis and closes the gap between the adjacent gates. Figures 4 and 5 show the upstream and downstream view of the seated blank. This completes the installation operation and the reverse of the process is used for removing the blank from the gap.

The instrumented existing 1:5-scale wicket gate on the right (looking downstream) and the aluminum gate on the left provide the supports for the blank. Any forces, hydrodynamic or static, acting on the blank will be transferred to the supporting gates through the gate-bottom attachment points. The actuator arm provides the necessary forces to keep the blank vertically aligned within a tolerable degree of freedom during an in-flow operation. An actuator, sensitive to the gate-top rotation about the dam axis, was used to keep the blank vertical during its insertion process and the actuator forces required to keep the gate vertically aligned were recorded. A winch mounted above the spillway crest was used to raise or lower the blank during installation or removal procedures. The winch cable was equipped with a load cell and the forces in the cable were measured during the tests.

A typical wicket blank installation experiment required that all of the wicket gates in the 1:5 model to be in raised position except for one (see Figures 6 and 7). Blank experiments were conducted with and without the actuator connected to the blank during its installation process. Figure 6 shows an installation

operation in which the actuator was disconnected. A sequence of blank wicket installing configurations is presented in Figures 8 to 13. As seen in Figure 8, when the actuator is engaged, the lifting force required to install the blank is the summation of the vertical components of forces on the actuator and the winch cable. When the actuator was disconnected, the lifting is solely a result of the wench cable tension registered during the installation process. In these figures, both 65- and 90-deg positions of the blank wicket are presented to illustrate the physical environment of the blank operations.

The wicket blank experiments were performed with the down wicket being adjacent to the instrumented wicket so that loads on the wicket and prop can be determined using the existing instrumentation. The overall operability of the blank was observed and documented. In the event when the wicket blank did not seat under its own weight, known weights were added to the top of the wicket to determine the force required inserting the blank (Figure 7). As seen in this figure, the additional weights were added to the top two channels of the blank. Experiments were also conducted to see the effects of changing the location of weights from top to the bottom channels. For various pool elevations, the hinge and prop rod forces on the instrumented adjacent wicket, and the actuator and winch cable forces were recorded.

The scaled blank model weighed about 152.75 lbf which corresponds to a prototype weight of 9.55 tons. This upscale prototype weight is about 12.32 percent higher than the original estimate of 8.5 tons. This increase in weight resulted partly because of the widening of the flange width of the blank edge tee-beams. The edge tee-beam outer flanges were widened by adding a strip of plate to each edge of the blank to ensure the proper placement of the blank over the adjacent wickets.¹ A safe placement of the blank over a gap requires that its edges ride adequately over the adjacent wickets. Observations of blank placement in a gap indicated that an inadvertent lateral shift of the blank towards one edge could cause the other end to slide off the adjacent wicket. This required expanding the width by $\frac{3}{4}$ in. on each side of the blank from its original model width dimension of 26.2 in. The new width of the blank in prototype scale becomes 11 ft, 6 $\frac{1}{2}$ in.

Scope

The scope of the work presented in this document included the measurements of forces required to install the blank in an open gap created by one inoperable wicket gate and the loads transferred to the adjacent wickets for the actual operational configurations listed in the following text. This testing plan was based on the instructions from the USAED, Louisville, in a memorandum dated 25 May 1999, subject: The Wicket Blank Testing Plan. These operational configurations included:

¹ Telecon Memorandum, Sverdrup/Gerwick, Date: December 1, 1999, Sub: DACW27-96-C-0099 Olmsted Dam Plans & Specs – Phase II.

- a. *Installation.* During this operation, the wicket blank was initially positioned with the bottom edges of the blank in contact with the top of the gates adjacent to the lowered gate and then lowered slowly by the winch (Figures 6 and 7). This test was done for the five headwater/tailwater conditions as shown:
- (1) Headwater = 300, tailwater = 300
 - (2) Headwater = 298, tailwater = 295
 - (3) Headwater = 300, tailwater = 295
 - (4) Headwater = 301, tailwater = 294
 - (5) Headwater = 301, tailwater = 291
- b. *Removal.* This test required the raising of the wicket blank by the winch from its fully seated position. The removal of the actuator-connected blank from its seated position is illustrated in Figures 14 to 16. The same operating sequences for the blank when the actuator was disconnected from it are shown in Figures 17 through 19. Two headwater/tailwater conditions were evaluated for this operation. These conditions were:
- (1) Headwater = 300, tailwater = 295
 - (2) Headwater = 300, tailwater = 290
- c. *Inplace.* This test measured the static forces transmitted to the instrumented gate for the installed and fully seated wicket blank (see Figure 14 for example). The test was conducted for headwater and tailwater elevations of 302.0 and 278.0, respectively.
- d. *Point load.* This test measured the contact load transmitted to the adjacent wickets during blank gate operation for the fixed blank gate positions. Two orientations of the gate, one at 65 deg and another at 90 deg, were used to record the static loads transmitted at the contact points. Figure 20 shows a typical 65-deg dry position of the blank gate. Figure 1 shows a 90-deg dry position of the blank gate. Two load cells were pinned to the bottom of blank to measure the transmitted load at the contact points as shown in Figures 20 and 21. For 10 fixed elevations, point load tests were conducted for four different pool elevations as listed below.
- (1) Headwater = 298, tailwater = 295
 - (2) Headwater = 300, tailwater = 295
 - (3) Headwater = 301, tailwater = 294
 - (4) Headwater = 301, tailwater = 291

2 Instrumentation, Data Acquisition, and Analysis

Instrumentation

A total of 18 different transducers recorded dynamic data for the 1:5-scale blank model. Figure 22 shows the sensor locations for the existing instrumented gate. These transducers included:

- a. Force normal to the face of the existing gate at the right hinge (r.h.) and the left hinge (l.h.).
- b. Force parallel to the face of the existing gate at the r.h. and the l.h.
- c. Prop load normal to the face of the existing gate.
- d. Winch cable force.
- e. Winch cable release indicator (measured the extension of the winch cable due to lowering of the blanket).
- f. Contact loads on the left and right contact points.
- g. Loads on the actuator that keeps the blank in upright position.
- h. U/S pool elevation (measured with a pressure transducer).
- i. D/S pool elevation (measured with a pressure transducer).
- j. Gate rotation. (Gate orientation was measured by a tiltmeter attached to the base of the gate.).
- k. Hoist cable rotation.
- l. Trigger mark indicator.

Figure 23 shows the general layout of the blank model orientation in the spillway cross section. As seen in the figure, the actuator pivots at el 312.35 mounted on the catwalk. Another end of the actuator is connected to the blank at

0.5 ft (model dimension) down from the top of the blank wicket. The locations of the load cells at bottom of the blank gate are also shown in Figure 20.

Data Acquisition and Analysis

System and operation

The data acquisition system for the Olmsted 1:5 Model Study consisted of one personal computer (PC) for data storage, data processing, and process control, an analog-to-digital converter (ADC), signal conditioning amplifiers, and a printer. Signal conditioning included continuous variable gain amplifiers, tracking filters, and antialias filters. The signal conditioning amplifiers were manufactured by Vishay and could supply gains up to 10,000. Custom-made programs were installed in the PC to regulate data acquisition and control gate position. The PC used to record data also contained a National Instruments AT-MIO-16F-5 ADC board and a Real Time Devices digital input/output (DIO) board. The DIO were used to activate the desired hydraulic system function for the experiment to be run. The ADC had a 12-bit resolution and was configured for -5 to +5 volt input range. The ADC was a printed circuit board that plugged into a PC expansion slot.

Custom software was written to take calibration measurements, record data during an experiment, and make time-history plots of the data recorded. MATLAB matrix analysis software was used for much of the data analysis; it contains many powerful numerical and graphical tools to manipulate matrices, perform frequency analyses, and plot graphs, as well as perform other crucial mathematical functions (The MathWorks, Inc. 1992).¹

Time domain analysis

The measured input was originally an analog signal. The front end converted the analog signal to a series of digital values. The digitized input signal as a set of N discrete values, evenly spaced in the period T , are recorded to display the time signal for each channel. Each channel is sampled at 500 samples per sec for about 205 sec (model dimension).

The real-time scope displays a number of input channels in a variety of formats. MATLAB (The MathWorks, Inc. 1992) was used to generate the time-domain data presented in this report. All packages allow mathematical operations of the recorded channel such that the units of measurement could be converted, the analytical operations could be performed, and data could be displayed in model or prototype units. As mentioned earlier, a custom program was used during the experiment to check the consistency and quality of the recorded data by observing each recorded channel on site. Time-domain signals could be displayed as function of time or as a function of gate insertion depth.

¹ The MathWorks, Inc. (1992). Matlab 5.3 product family, User's Guide, Natick, MA.

For a meaningful representation of the acquired data, all responses presented in this document are converted as a function of insertion depth. The insertion depth is the distance traversed by the blank gate as it is installed from the top to the seated position. A total depth of 4.6 ft is thus traversed by the blank model to close the gap completely. The insertion depth is 0 at the top during the start of the installation process (see Figure 6) and 4.6 ft at its seated position (see Figure 3). Data plots reference blank displacement or insertion depth as a direct relation to the measured value of cable length spooled from the winch drum. However, for some test conditions during installation/insertion of the wicket blank, the blank would stop moving and at the end of the tests when the blank seated and stopped moving, the winch cable would become slack. This resulted in slight discrepancies between the actual location (insertion depth) of the blank and the reported location. It should be noted that the amount of cable slack was minimized during the tests.

3 Results and Discussions

Introduction

The experimental results for various blank operations are presented in this section of the document. These operations included installation, removal, and in-place conditions of the blank wicket. For each test, actual forces exerted on the adjacent gates and the lifting force required placing the blank in the gap were recorded. The maximum amplitude of these responses for each test configurations is tabulated and the force-history as a function of insertion depth is presented. All numbers mentioned in this document are in model units. For conversion to prototype equivalents, the magnitude of force must be multiplied by a force scale multiplier of 125 or (5^3).

General Observations

These experiments were conducted to determine the overall operability of the blank wicket. The gate was lowered slowly by the winch from the top of the gates. Figures 6 and 7 show the beginning of the installation of blank wicket operation. As seen in the figures, the raised blank wicket is suspended from the top, and its bottom edges are in contact with the adjacent wickets. The gate is slowly inserted into the gap as the wench cable is released and the loads are recorded. The gate is inserted from the top as shown in Figures 8 through 10 and continued to go down until the gate is fully seated at el 279 (Figures 3 and 15). All elevations presented here are in prototype units. In the event the wicket blank does not seat on its own weight, incremental additional weights were inserted in the top channels until the gate smoothly closed the gap without getting stopped on its way down. Figure 7 shows such a situation in which the additional weights were inserted in the top channels to allow the gate to reach the fully seated position. Results for the actuator connected blank experiments are discussed below.

Actuator-Connected Experiments

A series of installation experiments using the actuator-connected blank indicated the difficulties in inserting the blank wicket to its full depth. For a 7-ft pool difference, the blank would not seat properly with an additional weight of

144.8 lbf, nor would it seat by tilting the gate about the dam axis over 11.5 deg from its upright position. Table 1 summarizes the experimental results for the actuator-connected blank wicket during the installation process. As seen in the table, several attempts have been made to insert the actuator-connected blank by changing the location of the added weights from bottom to top channels and by tilting the gate around its vertical axis. It is interesting to note that for the 5-ft pool difference, the blank could be lowered to its seated position when the additional weights were added on the bottom channels. For the same head difference, however, placing the weights on the top channels that simulate the actual prototype operation of the blank would not install the blank to its seated position. By tilting the blank about the dam axis (tilting the top of the gate in the downstream direction), however, the blank was able to reach its fully seated position.

Table 1 General Outline of Experimental Results for the Actuator-Connected Blank Wicket					
Test Number	Pool Levels, ft		Gate Angle, deg	Added Weight, lbf	Remarks on the Status of the Blank Test
	Up-stream	Down-stream			
Installation Experiments					
Blank1-6	Dry	Dry	65	n/a	Gate weight, 152.75 lbf
WBT1-3	300	300	"	None	Blank gate seats properly
WBT4-6	298	295	"	None	Blank gate seats properly
WBT7-9	300	295	"	None	Stops
WBT10	301	294	"	None	Stops
WBT11-12	300	295	"	20 (bottom loaded)	Almost went down to seated position
WBT13-14	300	295	"	39.66 (bottom loaded)	Blank gate seats properly
WBT15-19	300	295	"	39.66 to 144.8 (top loaded)	Stops and could not be lowered further down
WBT20	300	295	"	None	Did not go down by tilting the blank ~ 2 deg
WBT21-23	300	295	"	None	Tilting the blank gate whenever needed (~ 3.5 deg) enabled the blank to seat properly
WBT24-27	301	294	"	None	Could not be dropped by tilting the gate over 11.5 deg

The difficulties in inserting the blank passed a certain position along its insertion depth (stopped at about three-fourths of the full depth) was due to the vertical restraint provided by the actuator arm. The upward components of the actuator force required to keep the gate vertical barred the blank to move downward. Figure 23 shows the actuator position with respect to the blank gate.

To avoid this inadvertent situation of halting the blank placement to its seated position, experiments were conducted without removing the actuator and the results are presented in the following text.

Blank Experiment Results

General observation of the operability of the blank for various operating configurations and different pool conditions are summarized in Table 2. As indicated in the table, the blank wicket seated properly on its own weight when the pool differences were less than 5 ft (cases OLMWBT2 to OOLMWBT4). However, additional weights were needed to insert the blank to its full depth when pool difference exceeded 5 ft (cases OLMWBT5 to OLMWBT 6). A 7-ft pool difference required 68.32 lbf of additional weights on the channels (see Figures 24 through 27) to insert the gate to full depth. A 10-ft pool difference required 117.26 lbf of weights for smooth installation of the blank wicket. Five headwater/tailwater conditions were included for these installation experiments. The actuator was not connected to the blank during the installation experiments presented in Table 2.

Table 2 also presents the summary of the removal and in-place blank operations. During the removal, the wicket blank is raised by the winch from its fully seated position. Two headwater/tailwater conditions were included for this operation. In all cases, the gate was removed with no difficulty. The first two removal cases (OMWBT7 and OLMWBT8) used no actuator, and the gate remained at approximately a 65-deg position during the procedure. In the last two cases, the gate was initially rotated from its fully seated position at 65 deg to a 90-deg position using the actuator, and then the gate was removed using the winch cable.

The last two sets of data generated from conditions listed in Table 2 are for the in-place static test results for with and without the actuator connected blank operation. As mentioned earlier, the actuator was needed to keep the blank vertical during its installation process, to rotate the blank from its vertical orientation to a 65-deg position during installation, and to rotate the blank from its 65-deg seated position to a vertical orientation during removal. This test measured the static forces transmitted to the instrumented gate for the installed and fully seated wicket gate. The test was conducted for headwater and tailwater elevations of 302.0 and 278.0, respectively.

Table 2
General Layout of Blank Gate Experimental Results (Actuator disconnected unless mentioned otherwise)

Test Number	Pool Levels, ft		Gate Angle, deg	Load Added to Lower the Gate Into Full Depth, lbf	Remarks on Status of Blank Test
	Up-stream	Down-stream			
Installation Experiments					
OLMWBT1	Dry	Dry	65	None	Gate weight, 152.75 lbf
OLMWBT2B	300	300	"	None	Blank gate seats properly
OLMWBT3B	298	295	"	None	Blank gate seats properly
OLMWBT4	300	295	"	None	Blank gate seats properly
OLMWBT5	301	294	"	None	Stops
OLMWBT5C-E	301	294	"	68.32	Blank gate seats properly
OLMWBT6	301	291	"	None	Stops
OLMWBT6C-I	301	291	"	78.18 to 112.26	Did not go all the way down
OLMWBT6J-P	301	291	"	117.26	Blank closes the gap
Removal Experiments					
OLMWBT7B	300	295	65	None	Removed gate without actuator
OLMWBT8B	300	290	65	None	Removed gate without actuator
OLMWBT9C	300	290	65 - 90	None	Started at 65 deg, moved to 90 deg, then gate removed, actuator connected
OLMWBT10	300	295	65 - 90		Started at 65 deg, moved to 90 deg, then gate removed, actuator connected
Static Load Experiments					
OLMWBT11	302	278	65	None	In-place static load at 65 deg, no actuator connected
OLMWBT12	302	278	65	None	In-place static load at 65 deg, actuator connected

Data Analyses and Discussions

Selected sensor data for the experiments presented in Table 2 are presented in Figures 28 through 63. Note that the results presented in these figures correspond to the test numbers shown in Table 2. For repeated experiments, only the results for the successful one that enabled the blank to seat properly are selected for presentation. For example, among the four tests conducted for 7-ft pool elevations (OLMWBT5 and OLMWBT5C-E, see table above for test designations), only results for OLMWBT5D are presented for illustrations. As discussed previously, these figures are generated as a function of insertion depth starting from the top of the supporting wicket at el 302 to the seated bottom at el 279. Time-domain sensor responses and the blank displacement data are correlated to determine the forces (presented in these figures) as a function of insertion depth. The blank displacement is measured from the cable release from the wench drum. Note that the insertion depth is measured along the vertical direction, normal to the stream direction.

As seen in these figures, the apparent total insertion depth of about 5.1 ft exceeds the actual distance of 4.6 ft traversed by the blank model to close the gap completely. This discrepancy resulted because of sagging of the winch cable during the installation procedure. As explained earlier, during installation/insertion of the wicket blank, the blank would stop moving. At the end of the tests when the blank seated and stopped moving, the winch cable would become slack. For each experiment, seven plots are generated to show the forces transmitted on the existing wicket and the lifting force required installing the blank. Forces parallel and normal to the existing wicket for both hinges, and the prop rod forces indicate the variation of transmitted forces on the existing instrumented wicket as the gate is inserted or removed from the gap. Left and right directions correspond to the model orientation looking from upstream toward downstream. The blank orientation shows the rotation of the blank top from its upright position. As seen in the plots for the blank gate operation with and without the actuator connected (test numbers: OLMWBT8B and OLMWBT9C in Figures 59 and 63), the effects of actuator in holding the blank upright is noticeable. In cases when the actuator was not connected to the blank (Figure 59), the gate tilted over 30 deg from its upright position. While for the actuator-connected gate, the blank remained almost vertical during the course of its placement in the gap (Figure 63). The lifting force is the summation of the vertical forces measured during the operation of the blank in the model. For the actuator-connected blank, the summation of the vertical components of actuator force and the wench cable are used to compute the lifting force as a function of insertion depth. A free body diagram showing the directions of cable and actuator forces can be used to determine the lifting force as a function of time for the blank using the equation shown below (Figure 8).

When the insertion depth (ID) lies between 0 to 3.16 ft, the lifting force ($F_{lifting}$) equals:

$$F_{Lifting}(t) = F_{Cable}(t) * \cos\theta(t) - F_{Actuator} * \sin\alpha(t), \quad 0 \leq ID \leq 3.16 \quad (1)$$

and, for $ID > 3.16$,

$$F_{Lifting}(t) = F_{cable}(t) * \cos\theta(t) + F_{Actuator} * \sin\alpha(t) \quad (2)$$

where

$\theta(t)$ = angle between the cable and the vertical axis of the upright blank gate

$\alpha(t)$ = angle that the actuator arm makes with the horizontal axis

The magnitude of $\alpha(t)$ can be obtained as a function of time using the equation shown below:

$$\alpha(t) = \left[27^\circ - \left(\frac{27^\circ}{3.16} |ID| \right) \right], \dots (0 < ID \leq 3.16) \quad (3)$$

$$\alpha(t) = \left[28.77^\circ - \left(\frac{28.77^\circ}{2.07} |5.23 - ID| \right) \right], \dots (ID > 3.16) \quad (4)$$

Maximum amplitude of responses for all three operations are tabulated in Table 3. Forces include reaction forces on the existing gate and the lifting force recorded during the scheduled operations. In addition to the forces listed in Table 3, forces transmitted directly at contact points on the supporting existing wickets were measured. As shown in Figure 20, two load cells pinned to the bottom of blank measured the transmitted load at the contact points for fixed blank gate position.

Point-Load Results

During the point load test, the blank was kept stationary at 10 fixed elevations (see Figure 23 for elevation levels) and the data were recorded for fixed pool elevations as shown in Table 4. As seen in the table, eight cases with different pool and gate orientations were used to measure the contact point load (Figure 1). For the 65-deg position, the blank lay on the adjacent gates as shown in Figures 18 and 20. A 90-deg position of the point load test is shown in Figures 1 and 15. In this table, the gate angle is the blank gate orientation (clockwise) with respect to the stream direction. The maximum point forces is the maximum contact loads transmitted at the attachment points. The actuator force is the force required to keep the blank in position, and the gate elevation corresponds to the bottom of the blank location (position of load cell pinned to the bottom of blank) during the point-load test.

Table 3
Maximum Response Table for the Blank Gate Experiments

File Name	Upstream Pool, ft	Down-stream Pool, ft	Right Hinge Pin		Left Hinge Pin		Prop Rod Force, lbf	Lifting Force, lbf
			Normal Z Force, lbf	Parallel Y Force, lbf	Normal Z Force, lbf	Parallel Y Force, lbf		
Installation Experiments								
OLMWBT2B	300	300	-7	4.5	29	8	20	151
OLMWBT3B	298	295	-137.5	100.6	189.7	61	390	151
OLMWBT4	300	295	-225	102.9	267.8	93.5	535.8	151
OLMWBT5	301	294	-317	97.8	355.4	161.3	740.8	215
OLMWBT6N	301	291	-322	116.4	416.6	86.3	550.3	265
Removal Experiments								
OLMWBT7B	300	295	-130	37	228	125	174.5	163.5
OLMWBT8B	300	290	-238.5	87	395	198	365	162
OLMWBT9C	300	290	-84	-69.5	328	185.5	242	155
OLMWBT10	300	295	-60	28	174	60	130	155
Static Load Experiments								
OLMWBT11	302	278	110.33	145.5	779.3	407.5	1,167	n/a
OLMWBT12	302	278	-177	200	767	650.2	1,688.1	n/a

Table 4
Point-Load Experimental Results for the Blank Gate Operation

File Name	Up-stream Pool, ft	Down-stream Pool, ft	Gate Angle, deg	Max. Point Forces		Actuator Max. Force, lbf	Gate Elevation, ft
				Left, lbf	Right, lbf		
CASE - 1							
OLMWBT14	298	295	90	90.2	94.0	37.5	279
OLMWBT15C	298	295	90	77.4	81.7	34.4	281
OLMWBT16B	298	295	90	75.7	94.0	8.0	283
OLMWBT17C	298	295	90	74.0	76.5	11.1	285
OLMWBT18B	298	295	90	62.4	55.4	15.8	287
OLMWBT19C	298	295	90	53.3	58.1	19.9	289
OLMWBT20B	298	295	90	43.2	57.8	22.9	291
OLMWBT21C	298	295	90	27.3	47.4	18.9	293
OLMWBT22B	298	295	90	14.6	28.8	20.9	295
OLMWBT23C	298	295	90	10.2	20.3	19.9	297
CASE - 2							
OLMWBT25C	298	295	65	170.9	121.9	51.8	279
OLMWBT26B	298	295	65	155.8	112.2	-37.6	281
OLMWBT27	298	295	65	140.9	99.2	-45.8	283
OLMWBT28B	298	295	65	128.4	72.4	-72.2	285
OLMWBT29	298	295	65	117.1	63.6	-71.2	287
OLMWBT30	298	295	65	112.1	81.2	-28.5	289
OLMWBT31B	298	295	65	94.4	45.4	-80.3	291
OLMWBT32	298	295	66.5	64.6	41.7	-85.4	293
OLMWBT33	298	295	69.3	44.5	29.1	-72.2	295
OLMWBT34C	298	295	72	29.7	13.3	-61.1	297
CASE - 3							
OLMWBT35B	300	295	90	130.9	132.4	99.6	279
OLMWBT36C	300	295	90	122.5	121.3	100.6	281
OLMWBT37B	300	295	90	114.6	116.7	54.8	283
OLMWBT38B	300	295	90	116.1	109.4	60.9	285
OLMWBT39B	300	295	90	115.8	115.1	50.5	287
OLMWBT40C	300	295	90	99.6	91.7	53.5	289
OLMWBT41B	300	295	90	75.0	73.9	42.4	291
OLMWBT42C	300	295	90	46.6	50.5	33.2	293
OLMWBT43	300	295	90	22.2	28.0	31.2	295
OLMWBT44	300	295	90	4.8	9.6	31.2	297

(Sheet 1 of 3)

Table 4 (Continued)							
File Name	Up-stream Pool, ft	Down-stream Pool, ft	Gate Angle, deg	Max. Point Forces		Actuator Max. Force, lbf	Gate Elevation, ft
				Left, lbf	Right, lbf		
CASE - 4							
OLMWBT45	300	295	65	197.0	168.3	138.8	279
OLMWBT46B	300	295	65	184.2	157.8	32.2	281
OLMWBT47	300	295	65	175.2	144.9	-26.6	283
OLMWBT48C	300	295	65	158.4	128.0	-59.1	285
OLMWBT49	300	295	65	141.9	106.6	-91.6	287
OLMWBT50C	300	295	65	124.0	93.4	-108.6	289
OLMWBT51	300	295	65	106.8	67.2	-130.9	291
OLMWBT52	300	295	66.3	82.8	57.6	-122.8	293
OLMWBT53C	300	295	69.2	57.3	44.1	-96.4	295
OLMWBT54B	300	295	72.3	32.3	25.2	-76.1	297
CASE - 5							
OLMWBT55C	301	294	90	186.0	172.8	145.2	279
OLMWBT56	301	294	90	162.8	165.5	124.9	281
OLMWBT57	301	294	90	161.1	159.4	98.5	283
OLMWBT58	301	294	90	156.7	151.2	89.4	285
OLMWBT59C	301	294	90	147.4	135.2	89.4	287
OLMWBT60	301	294	90	130.9	113.3	57.9	289
OLMWBT61B	301	294	90	98.1	86.7	34.6	291
OLMWBT62C	301	294	90	59.0	65.1	27.5	293
OLMWBT63C	301	294	90	30.6	30.7	12.2	295
OLMWBT64C	301	294	90	12.9	8.3	18.3	297
CASE - 6							
OLMWBT65	301	294	65	278.8	241.7	193.0	279
OLMWBT66B	301	294	65	262.3	206.7	2.9	281
OLMWBT67	301	294	65	235.6	169.0	-56.8	283
OLMWBT68	301	294	65	212.9	120.8	-127.9	285
OLMWBT69	301	294	65	190.3	88.7	-183.7	287
OLMWBT70B	301	294	65	170.5	129.6	-117.7	289
OLMWBT71	301	294	65	147.9	132.2	-82.2	291
OLMWBT72	301	294	66.4	113.3	84.3	-114.7	293
OLMWBT73B	301	294	69.2	78.8	52.8	-91.3	295
OLMWBT74C	301	294	72.4	51.5	30.9	-79.1	297

(Sheet 2 of 3)

Table 4 (Concluded)							
File Name	Up-stream Pool, ft	Down-stream Pool, ft	Gate Angle, deg	Max. Point Forces		Actuator Max. Force, lbf	Gate Elevation, ft
				Left, lbf	Right, lbf		
CASE - 7							
OLMWBT75C	301	291	65	322.7	317.1	301.6	279
OLMWBT76	301	291	65	325.3	255.1	-7.0	281
OLMWBT77B	301	291	65	290.4	236.5	-82.2	283
OLMWBT78B	301	291	65	257.9	187.1	-84.2	285
OLMWBT79C	301	291	65	244.8	227.3	27.6	287
OLMWBT80B	301	291	65	198.9	176.1	-24.2	289
OLMWBT81C	301	291	65	147.7	88.0	-151.3	291
OLMWBT82B	301	291	66.4	107.2	50.9	-122.8	293
OLMWBT83D	301	291	69.2	66.8	38.6	-86.2	295
OLMWBT84	301	291	72.3	40.7	41.5	-41.5	297
CASE - 8							
OLMWBT85C	301	291	90	263.5	238.6	168.5	279
OLMWBT86B	301	291	90	249.9	233.6	144.1	281
OLMWBT87	301	291	90	233.7	227.8	118.7	283
OLMWBT88B	301	291	90	217.2	234.5	91.3	285
OLMWBT89D	301	291	90	198.0	181.1	65.9	287
OLMWBT90C	301	291	90	165.0	148.4	15.1	289
OLMWBT91C	301	291	90	109.0	107.5	18.1	291
OLMWBT92C	301	291	90	66.4	76.3	-7.3	293
OLMWBT93	301	291	90	36.8	48.3	-8.3	295
OLMWBT94B	301	291	90	19.2	23.7	-1.2	297

(Sheet 3 of 3)

4 Observations and Conclusions

The overall width of the wicket blank was increased from 10 ft, 11 in. to 11 ft, 6.5 in. This modification to the blank design was necessary to ensure adequate contact area between both edges of the wicket blank and the adjacent wicket gates.

No significant operational problems were discovered during this investigation. The wicket blank and the proposed installation and removal procedures proved to be adequate. The experimental results for various blank operations are presented in this document.

It should again be noted that because of differences between the hydraulically operated wickets reproduced in the model and the proposed horse wicket design, the insertion depth of the wicket blank will be greater in the field. The model simulated an insertion depth to el 279.0, and the proposed insertion depth is at el 275.85. The primary difference will be additional hydrostatic forces that were not simulated in the model below el 279.0. With this in mind, the results of this model investigation can be used to design necessary equipment and appurtenances for wicket blank operations in the field.



Figure 1. View from the walk, looking downstream at the wicket blank and wicket gates #4, #5, and #6. The bottom of the blank is at el 287 and at an angle of 90 deg. Dry bed photo

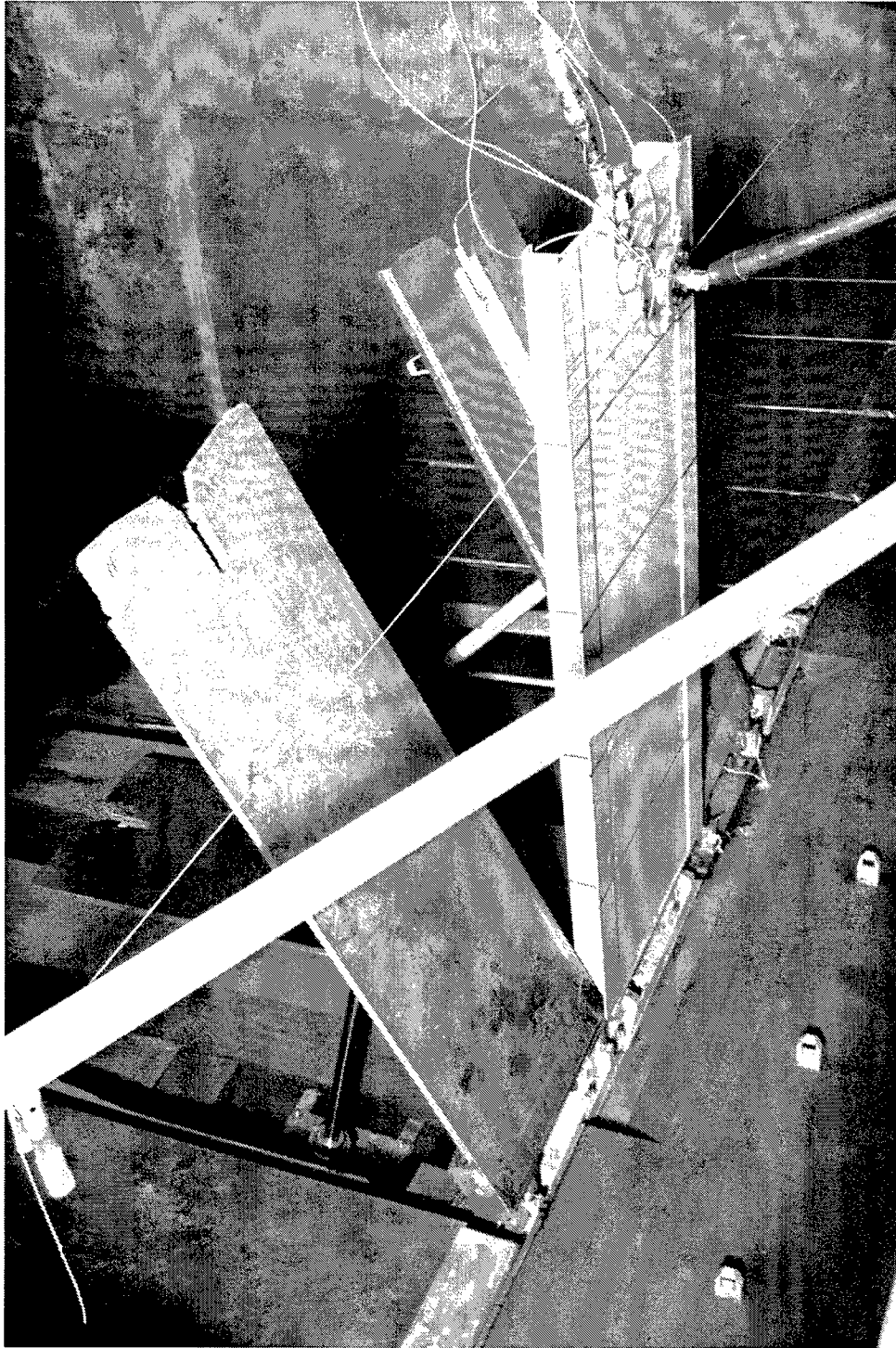

0004-027.jpg
Figure 2. View from the walk, looking downstream at the blank seated on wicket gate #5 at an angle of 90 deg. Dry bed photograph



Figure 3. View from the walk, looking upstream at the blank seated on wicket gate #5 at an angle of 90 deg. Dry bed photograph

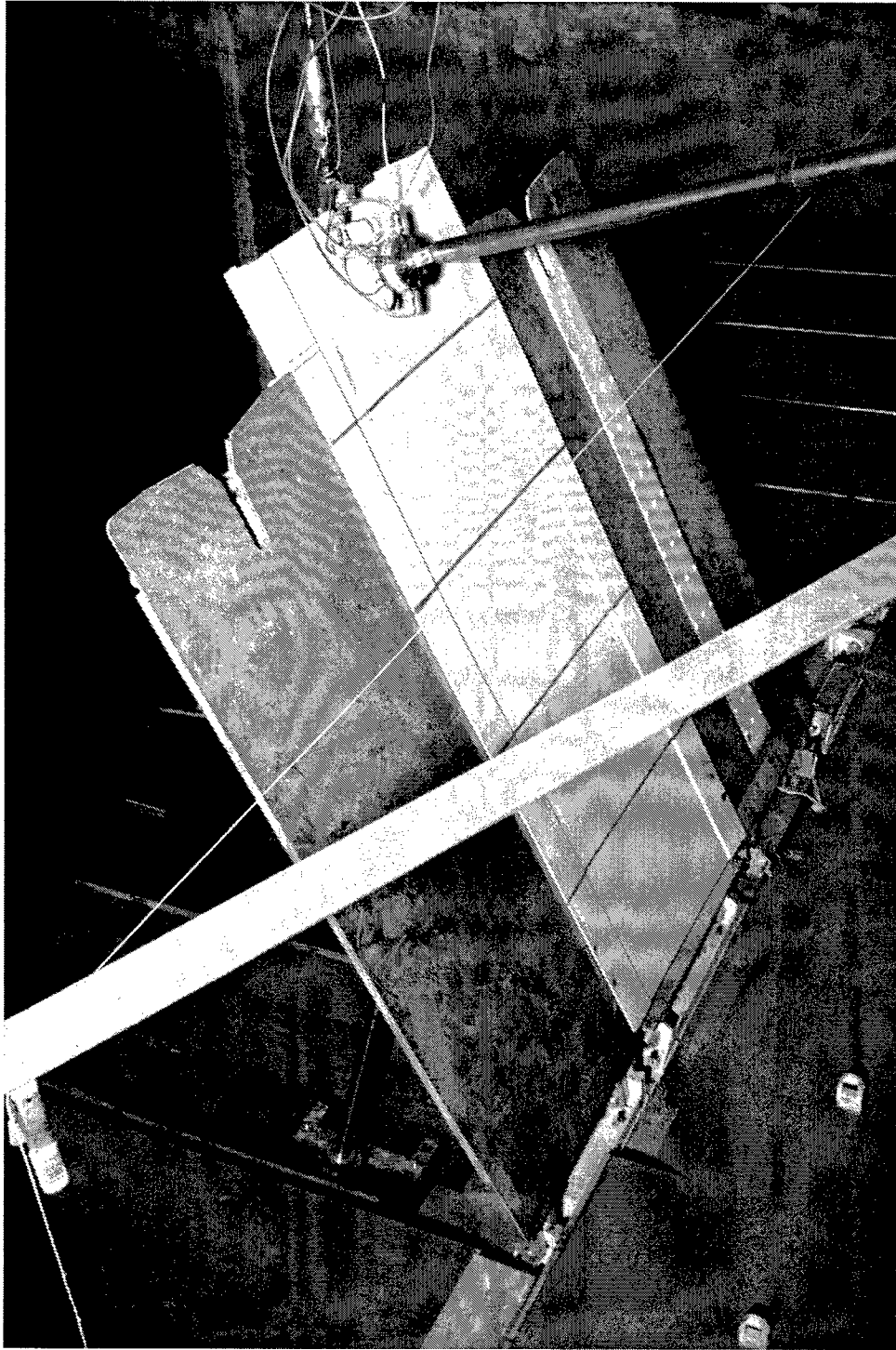

Figure 4. View from the walk, looking downstream at the blank seated on wicket gate #5 at an angle of 65 deg. Dry bed photograph



02004-025.jpg

Figure 5. View from the walk, looking upstream at the blank seated on wicket gate #5 at an angle of 65 deg. Dry bed photograph

Part C; Blank installation; cylinder disconnected:

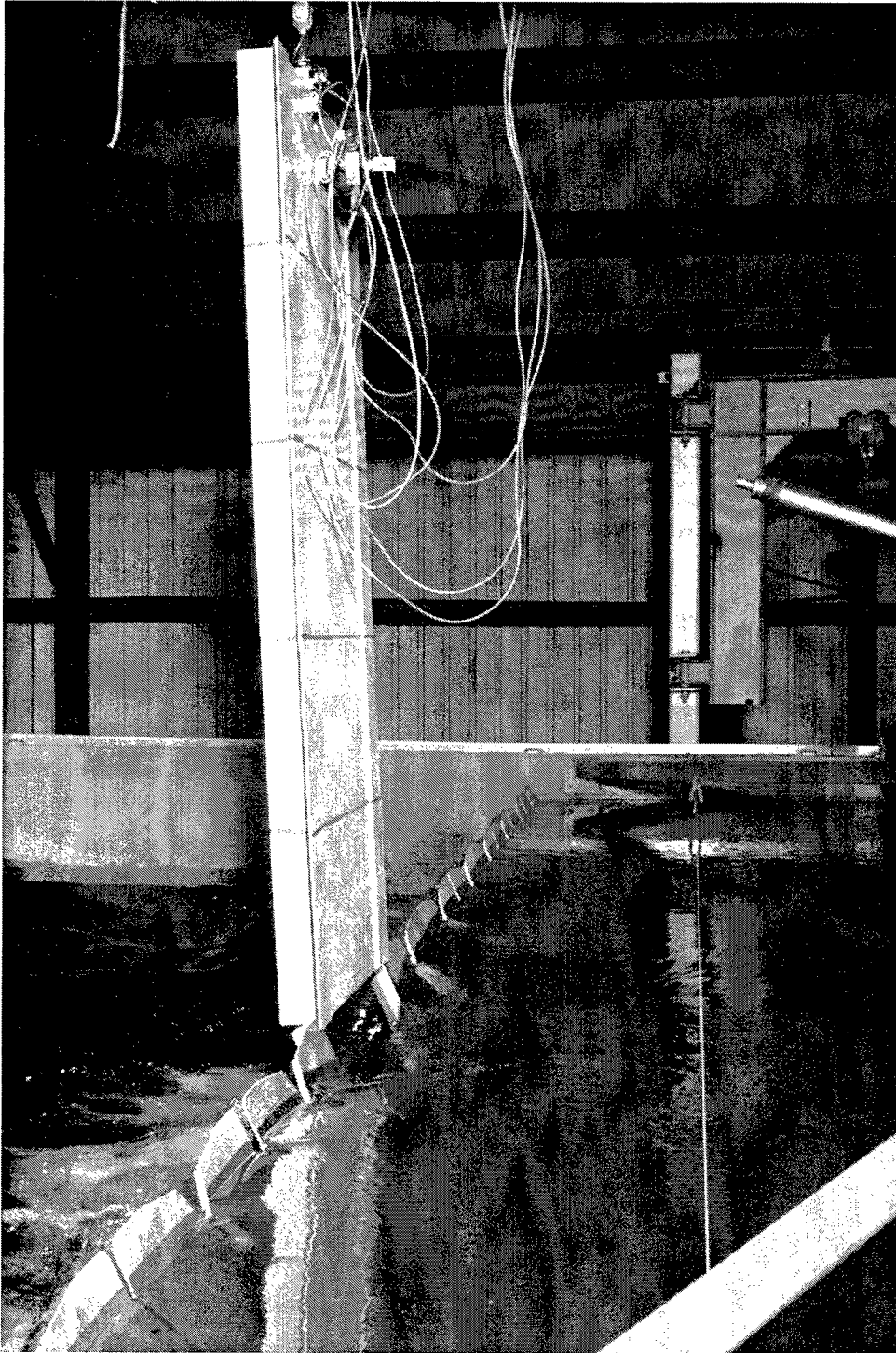

Figure 6. View from the walk, looking downstream at the blank in the raised position for installation. The blank has been weighted with 68.32 lb of lead positioned in the upper three channels. Headwater 301; Tailwater 294; 7-ft differential



Figure 7. View from the catwalk, looking upstream at the blank in the raised position for installation. The blank has been weighted with 68.32 lb of lead positioned in the upper three channels. Headwater 301; Tailwater 294; 7-ft differential

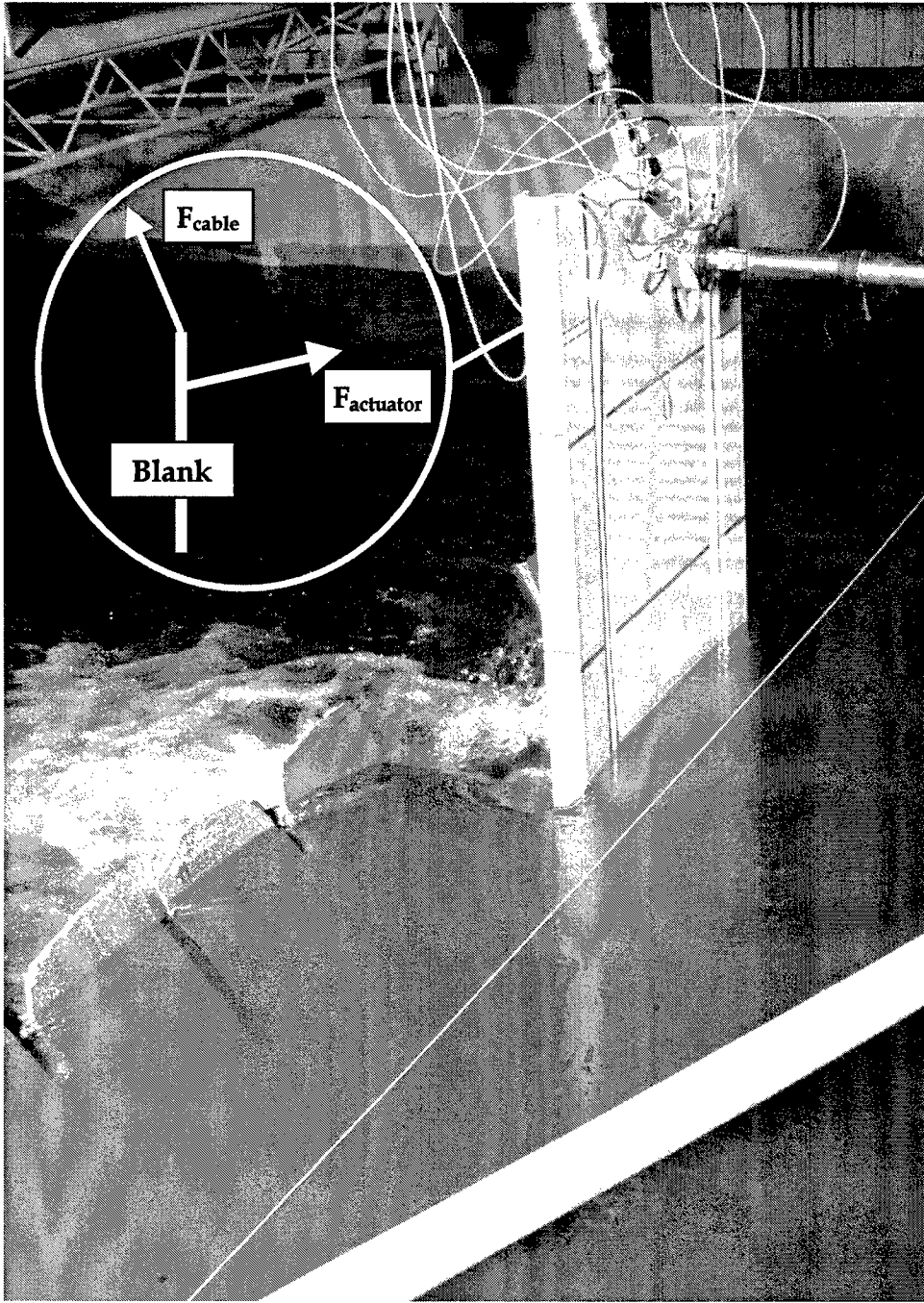
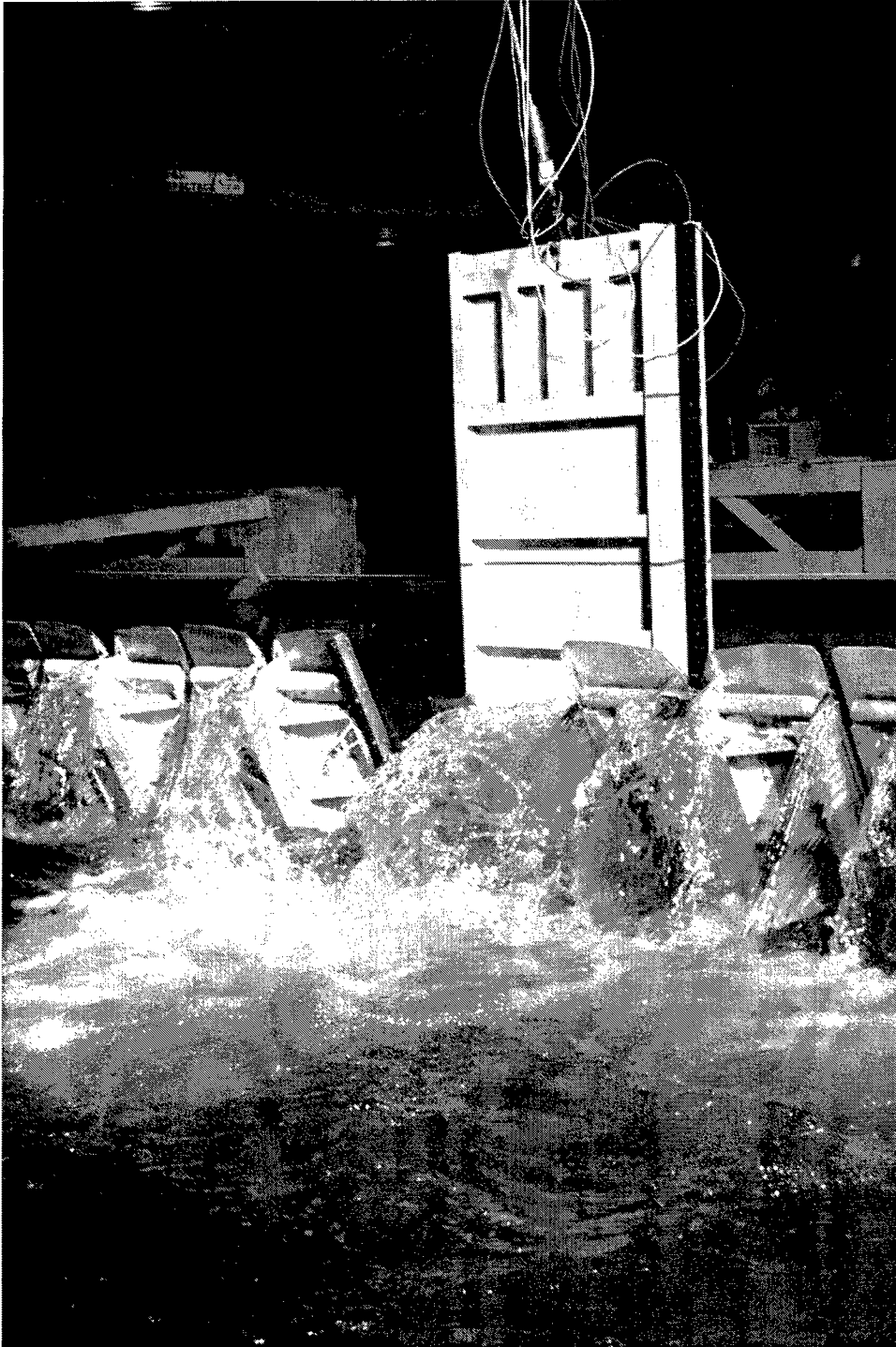

Figure 8. View from the walk, looking downstream at the blank at el 287 and an angle of 90 deg. Headwater 301, Tailwater 294; 7-ft differential



02004-013.jpg

Figure 9. View from the walk, looking upstream at the blank at el 287 and an angle of 90 deg. Headwater 301, Tailwater 294; 7-ft differential



Figure 10. View from the catwalk, looking upstream at the blank at el 287 and an angle of 90 deg. Headwater 301, Tailwater 294; 7-ft differential



c5204-019.jpg

Figure 11. View from the walk, looking upstream at the blank at el 287 and an angle of 65 deg. Headwater 301, Tailwater 294; 7-ft differential

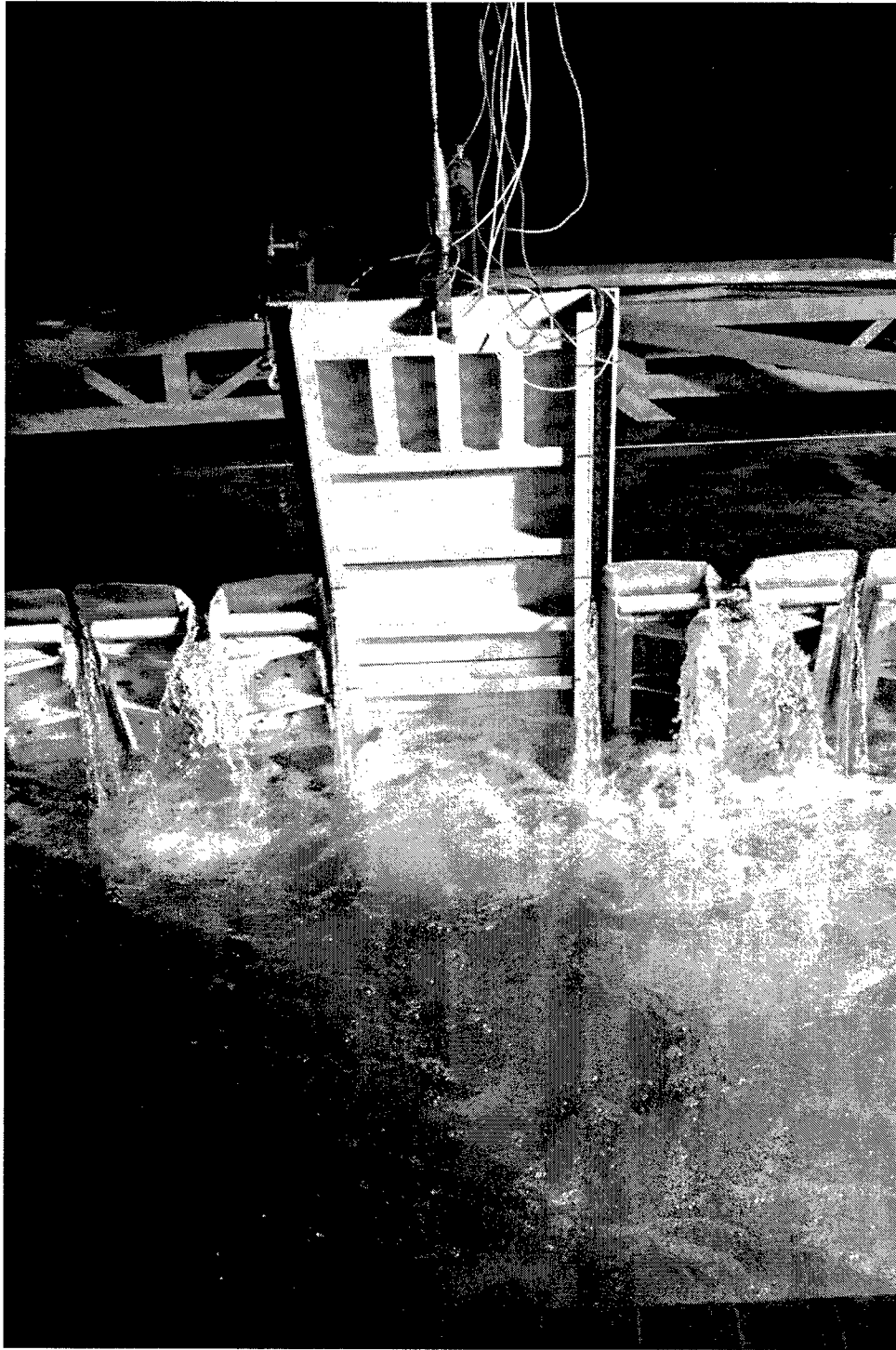
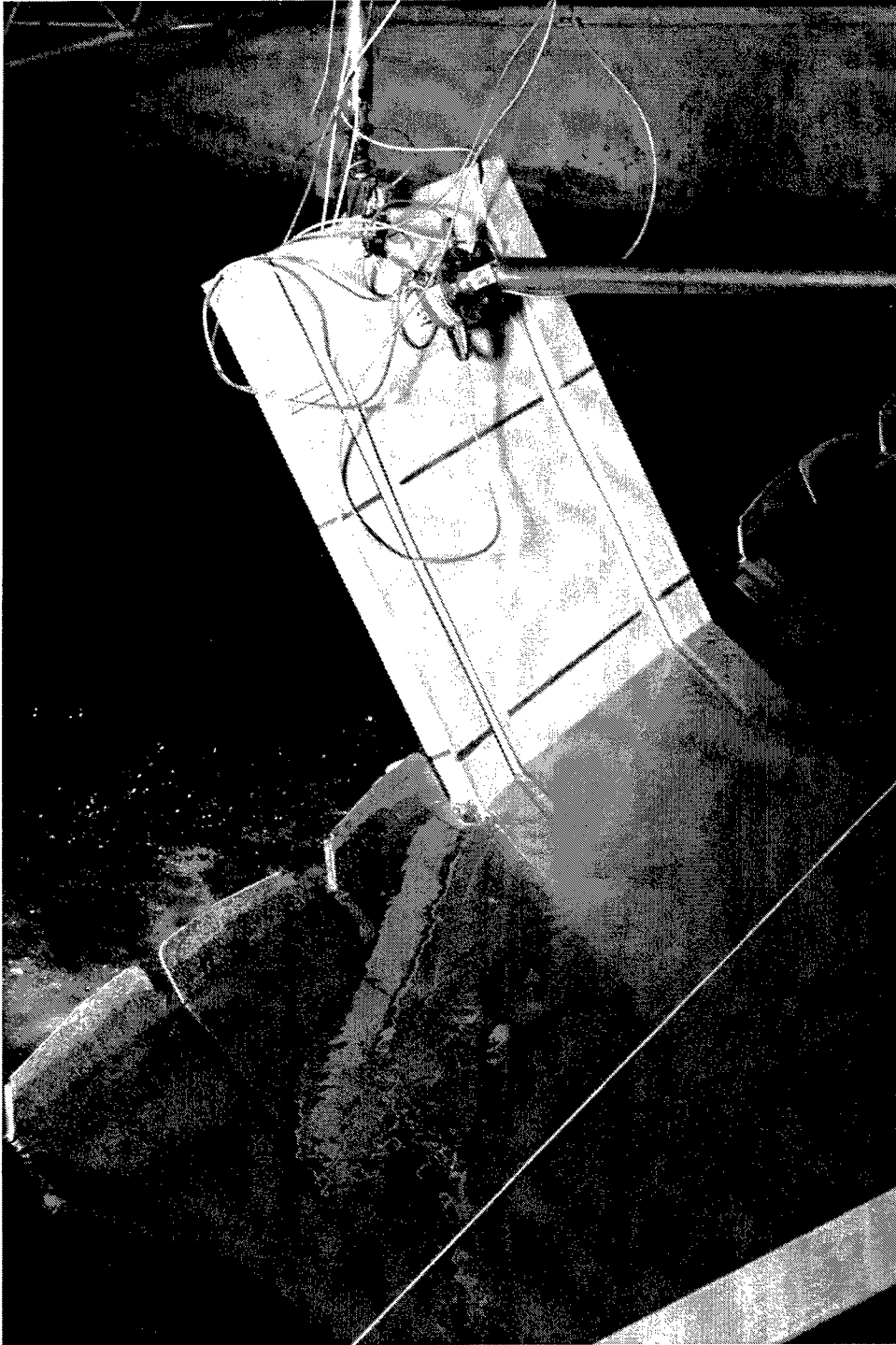

Figure 12. View from the catwalk, looking upstream at the blank at el 287 and an angle of 65 deg. Headwater 301, Tailwater 294; 7-ft differential



0004-022.jpg

Figure 13. View from the walk, looking downstream at the blank at el 287 and an angle of 65 deg. Headwater 301, Tailwater 294; 7-ft differential

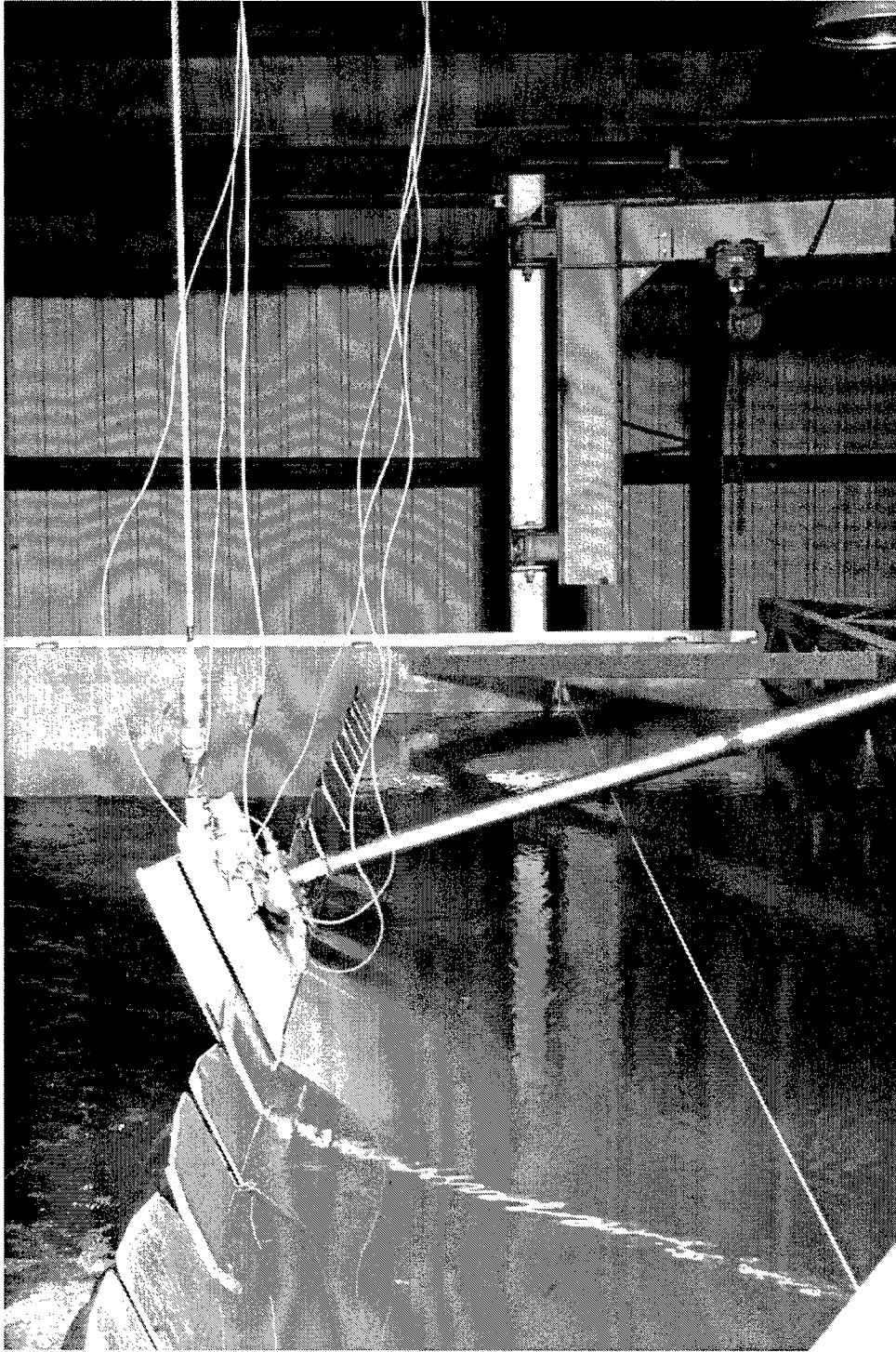

Figure 14. View of the blank, seated on wicket gate #5 at an angle of 65 deg, prior to removal. Headwater 300; Tailwater 295; 5-ft differential

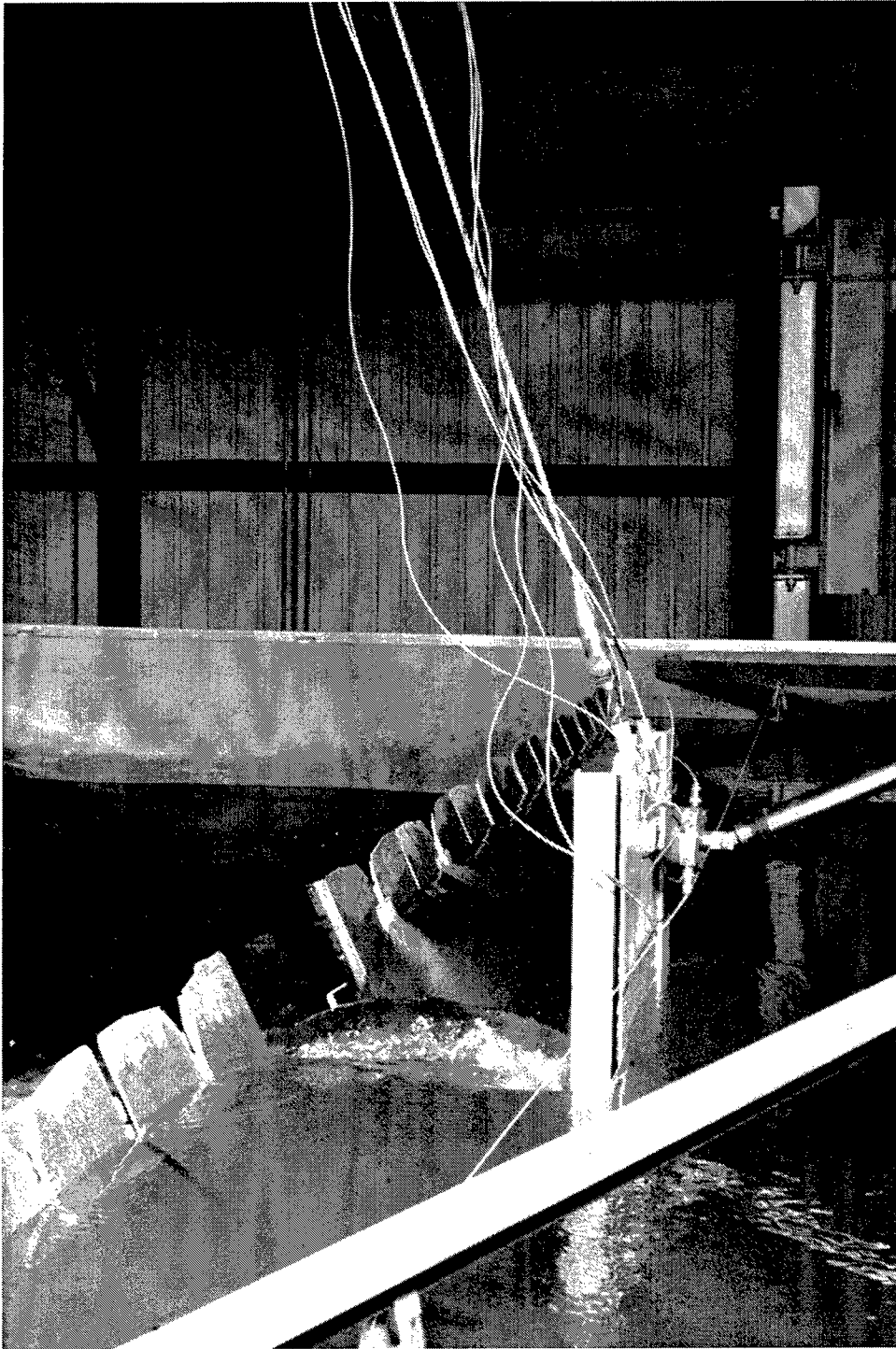

Figure 15. View of the blank, at a 90-deg angle, in the process of being removed. Headwater 300; Tailwater 295; 5-ft differential

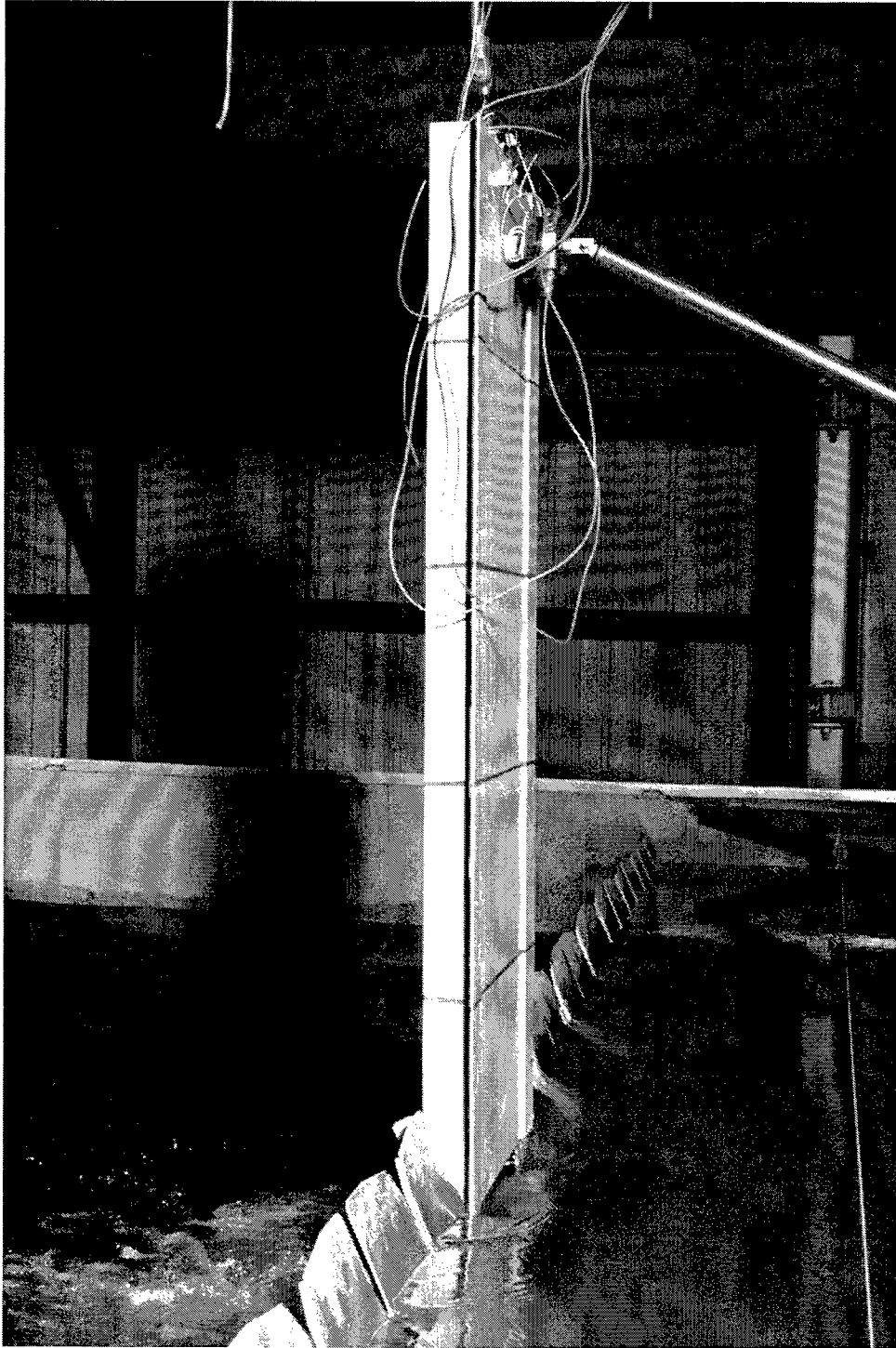

Figure 16. View from the walk as the bottom of the blank clears the water surface during the removal process. Headwater 300; Tailwater 295; 5-ft differential

Part C; Blank removal; cylinder disconnected:

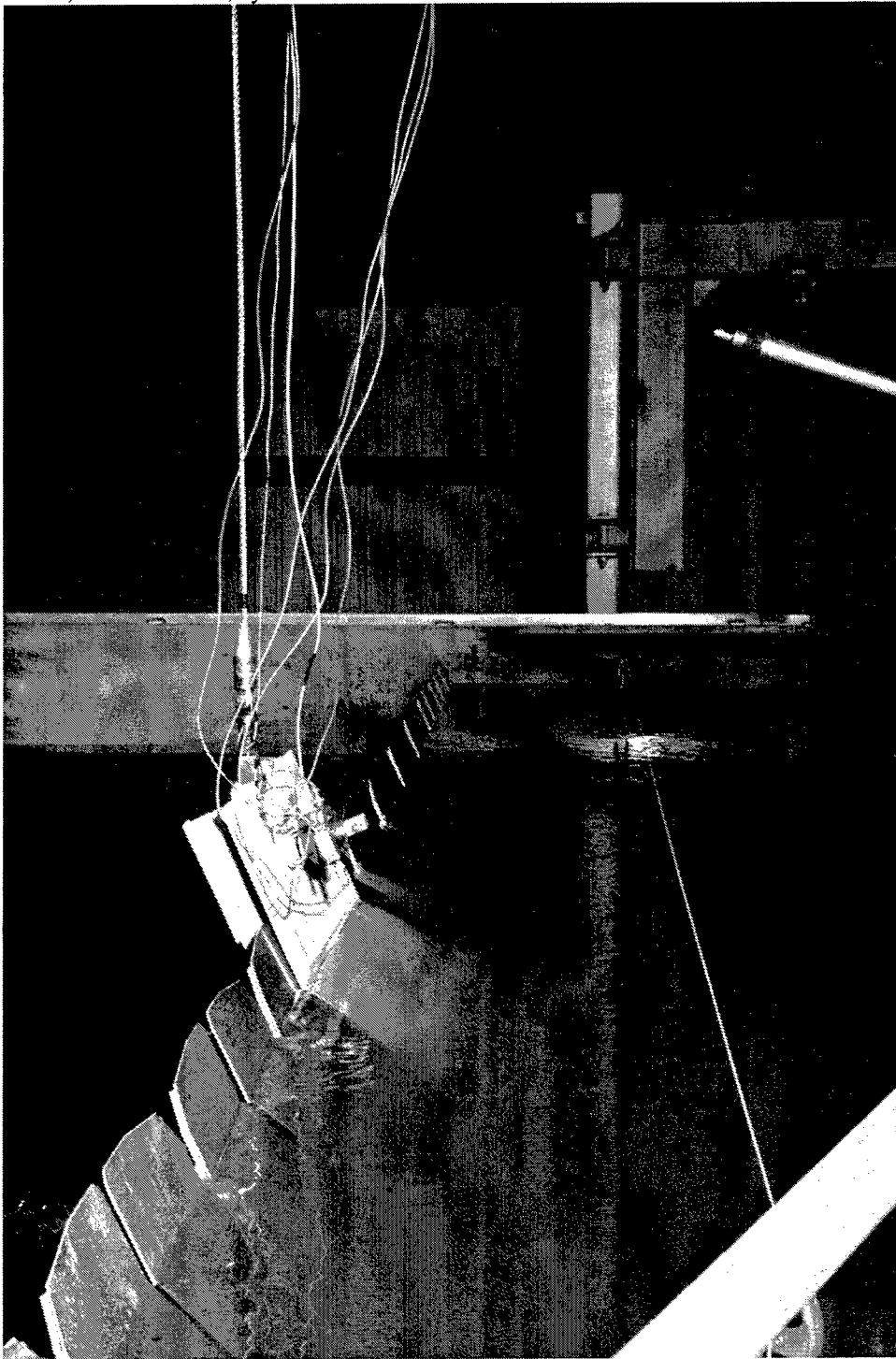

Figure 17. View of the blank, seated on wicket gate #5 at an angle of 65 deg, prior to removal. Headwater 300; Tailwater 295; 5-ft differential

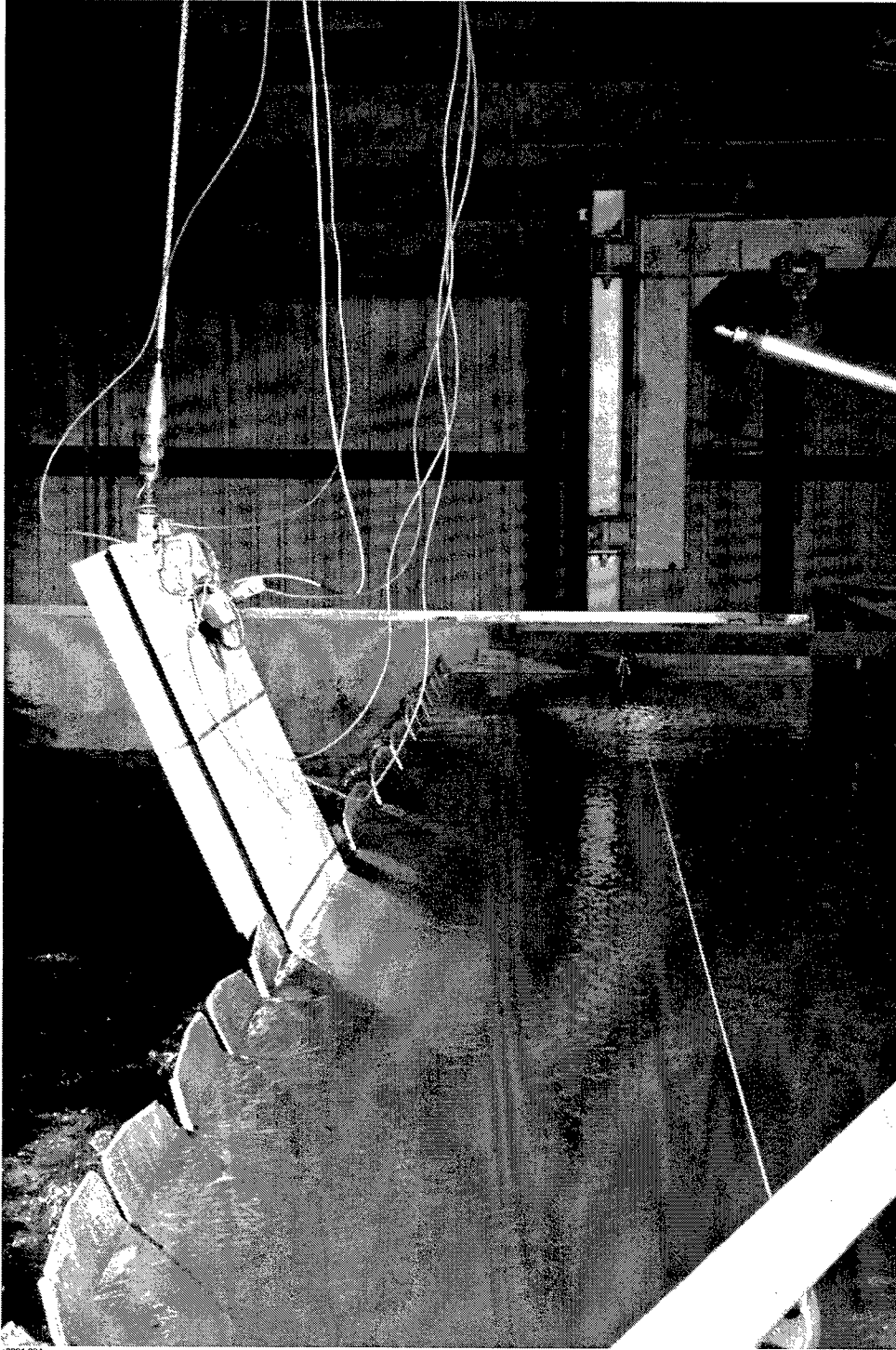

Figure 18. View from the walk of the blank approximately half way out of the water, still at approximately a 65-deg angle. Headwater 300; Tailwater 295; 5-ft differential

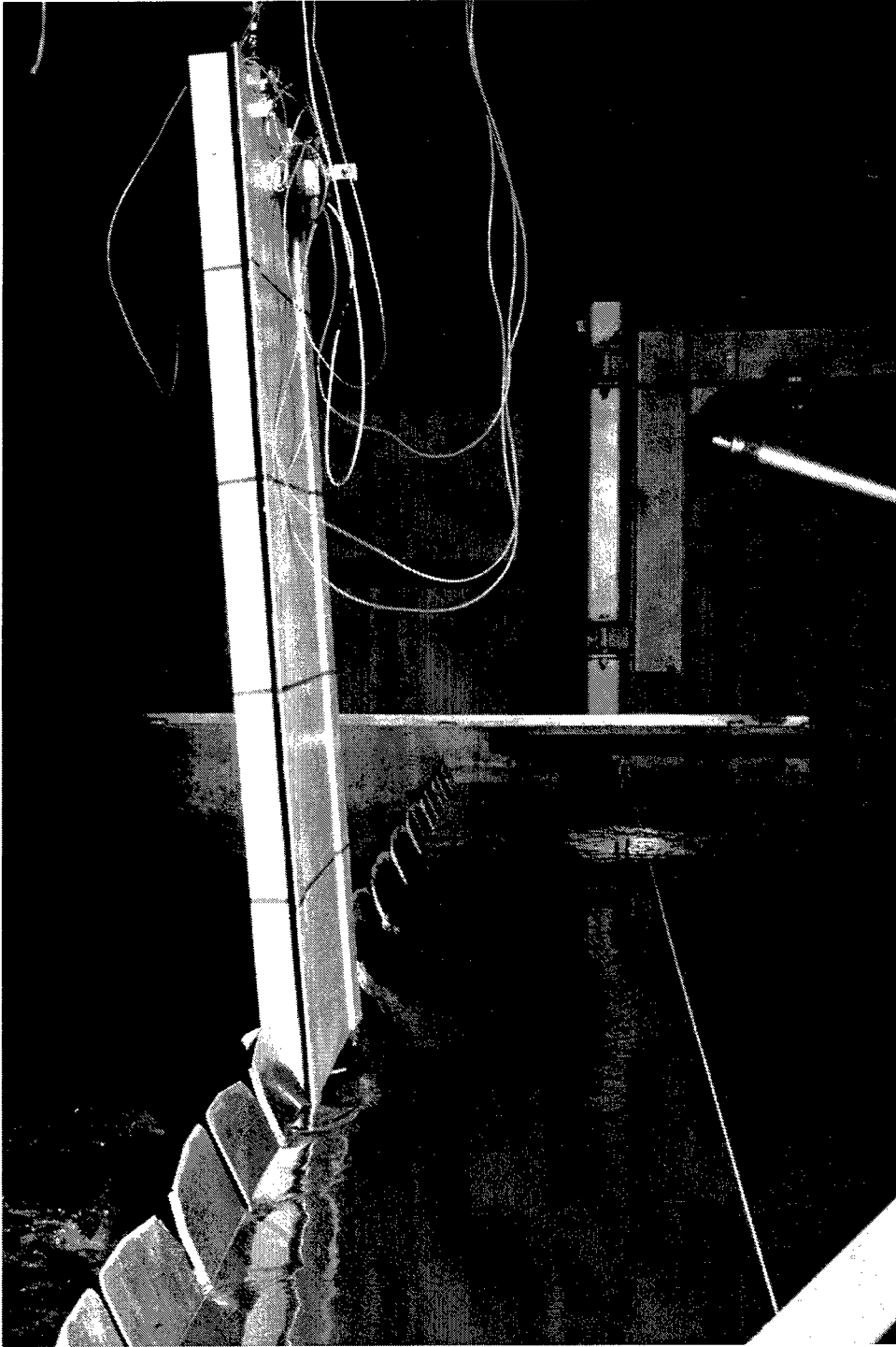

Figure 19. View from the walk as the bottom of the blank clears the water surface during the removal process. Headwater 300; Tailwater 295; 5-ft differential

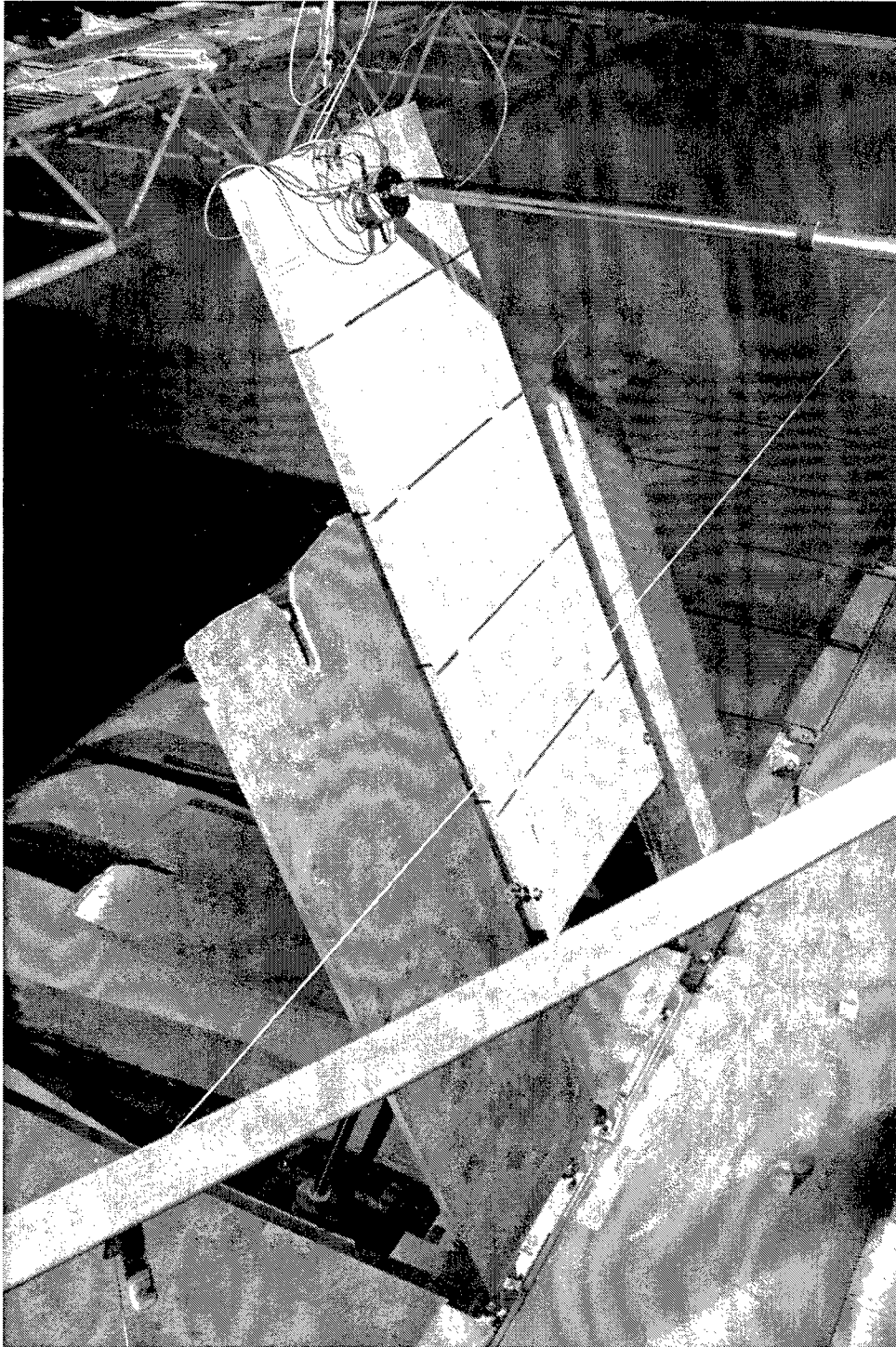

Figure 20. View from the walk, looking downstream at the wicket blank and wicket gates #4, #5, and #6. The bottom of the blank is at el 287 and at an angle of 65 deg. Dry bed photo

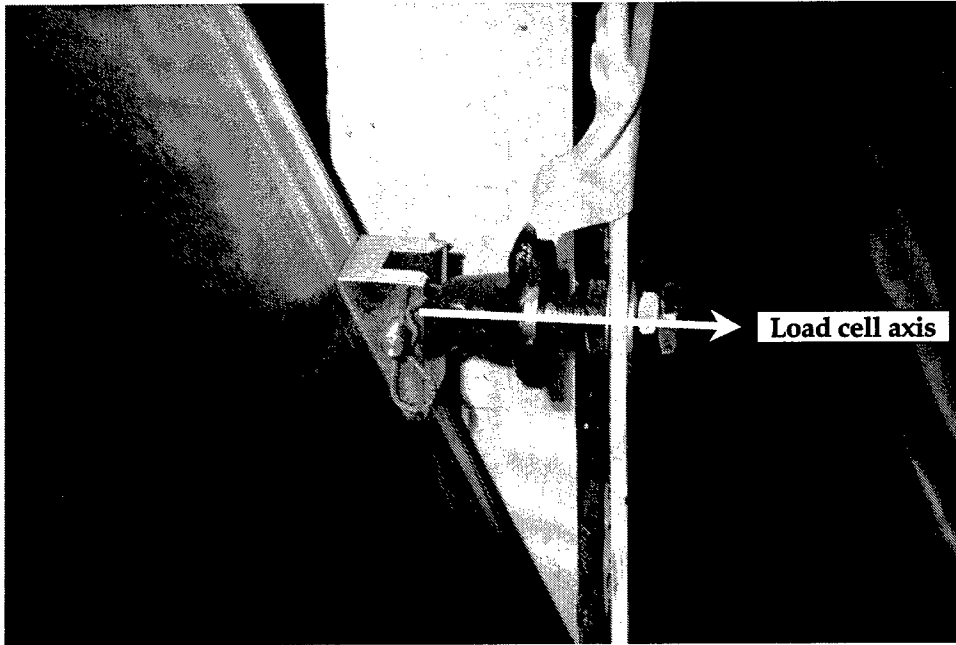

Figure 21. Closeup view of one load cell, showing contact between wicket gate #4 and the load cell attached to the blank. The bottom of the blank is at el 287 and at an angle of 90 deg. Dry bed photo

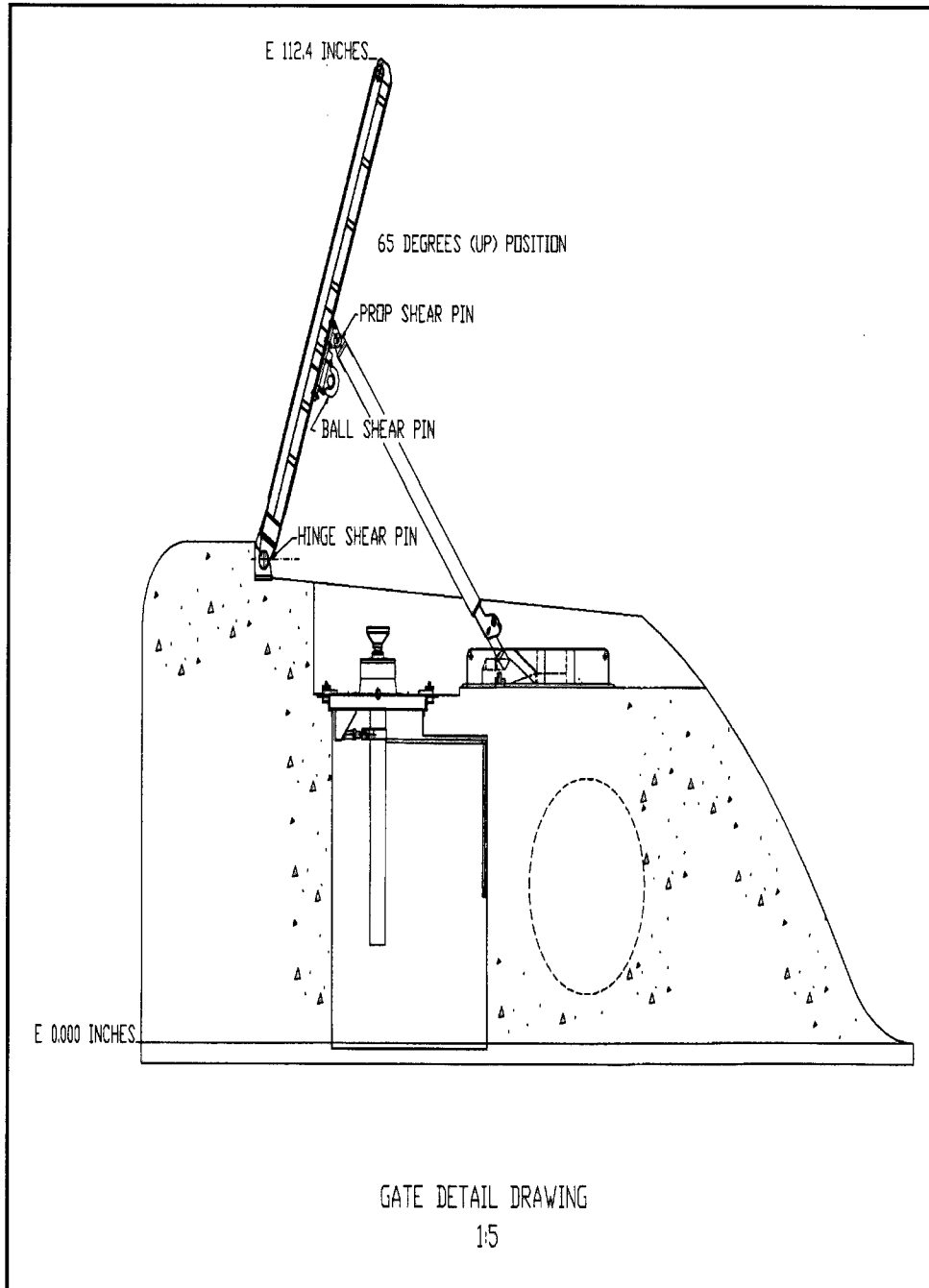

Figure 22. Instrumentation shear pin locations on instrumented gate

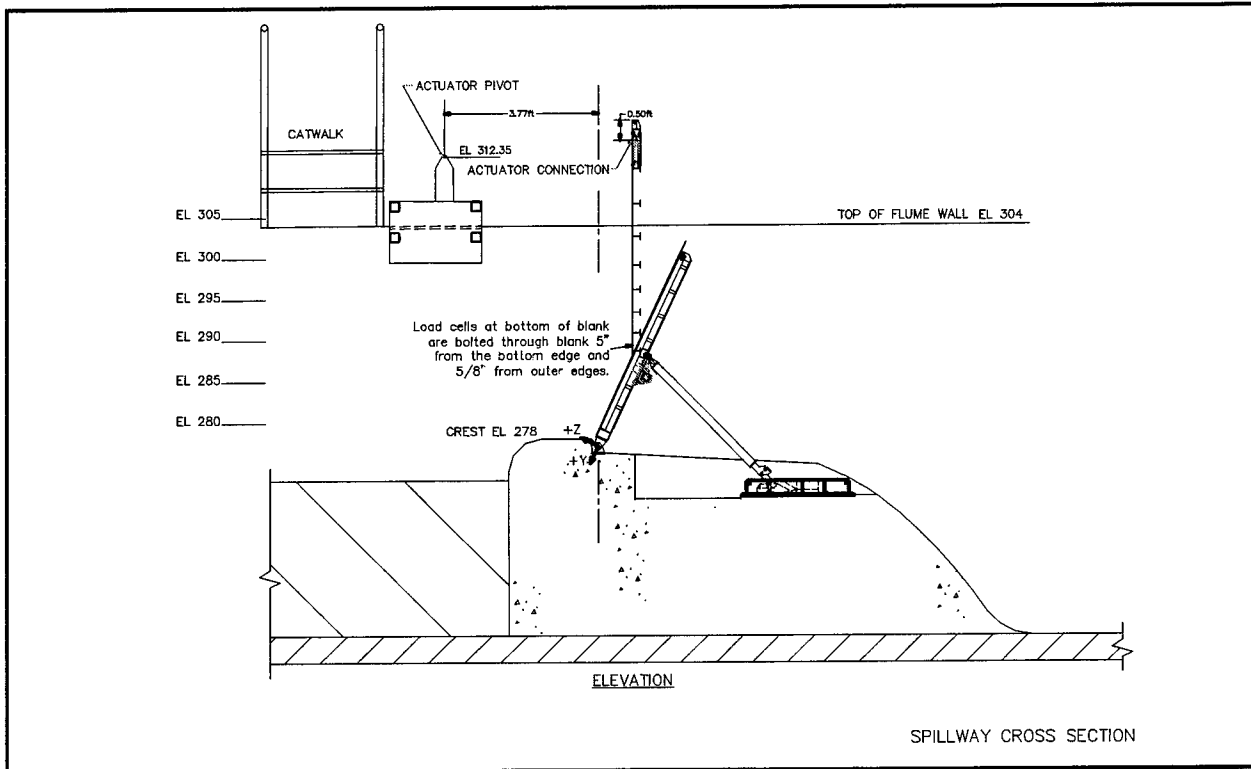

Figure 23. Blank gate orientation on the spillway cross section

Part C; Blank installation; cylinder disconnected:

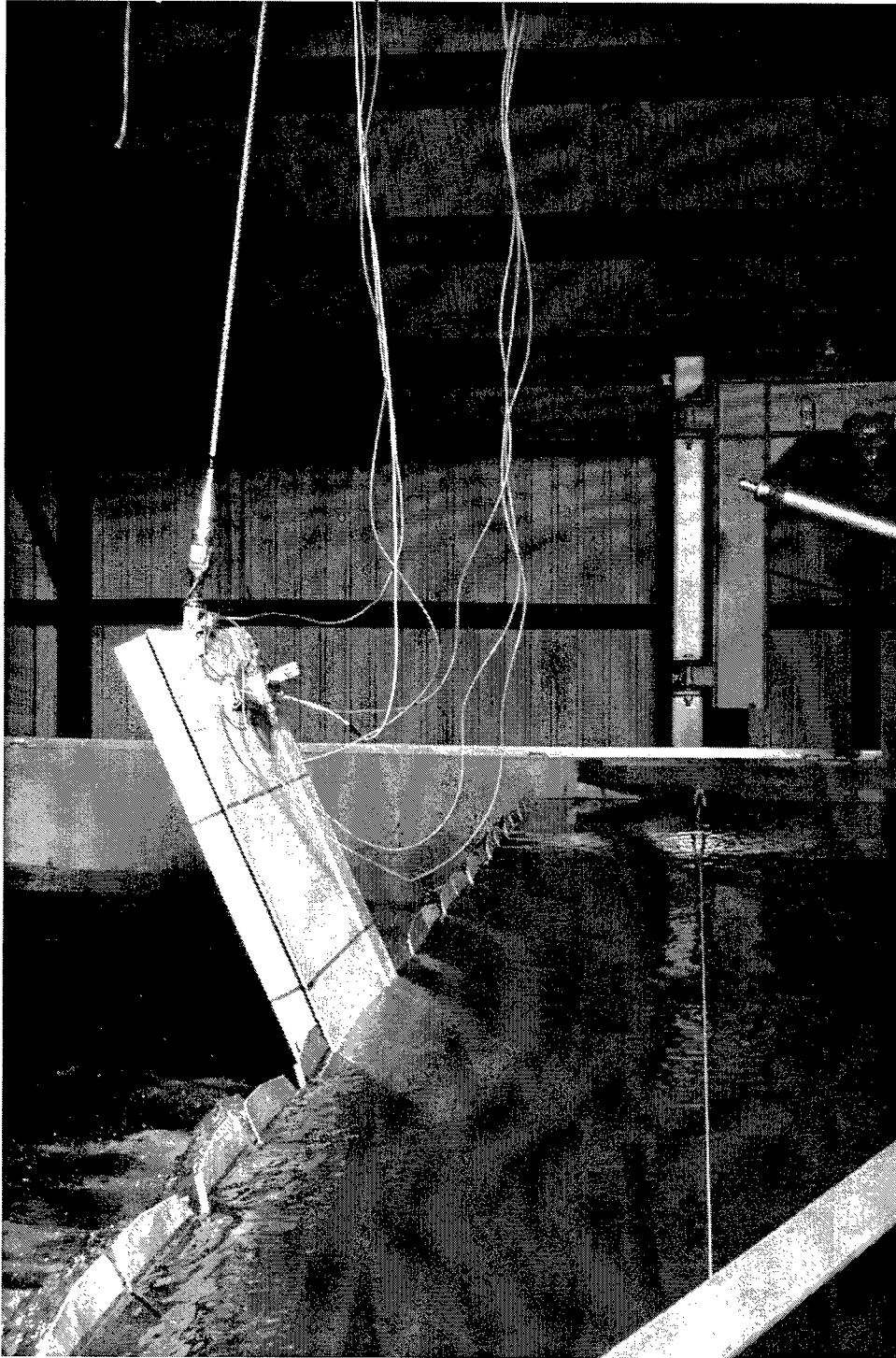

Figure 24. View from the walk looking downstream, as the blank is approximately half way submerged in the flow. The blank is weighted with 68.32 lb of lead positioned in the upper three channels. Headwater 301; Tailwater 294; 7-ft differential

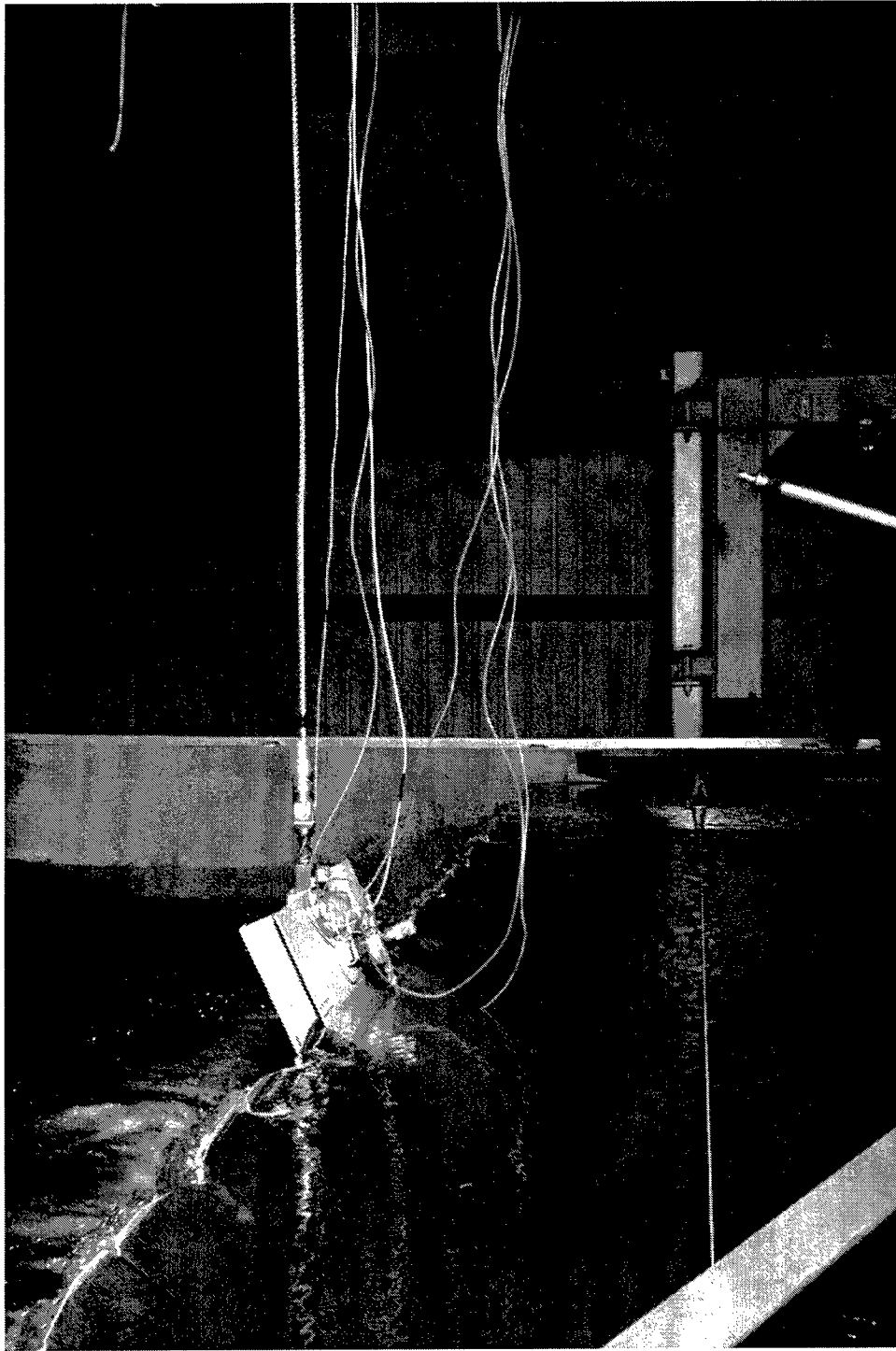
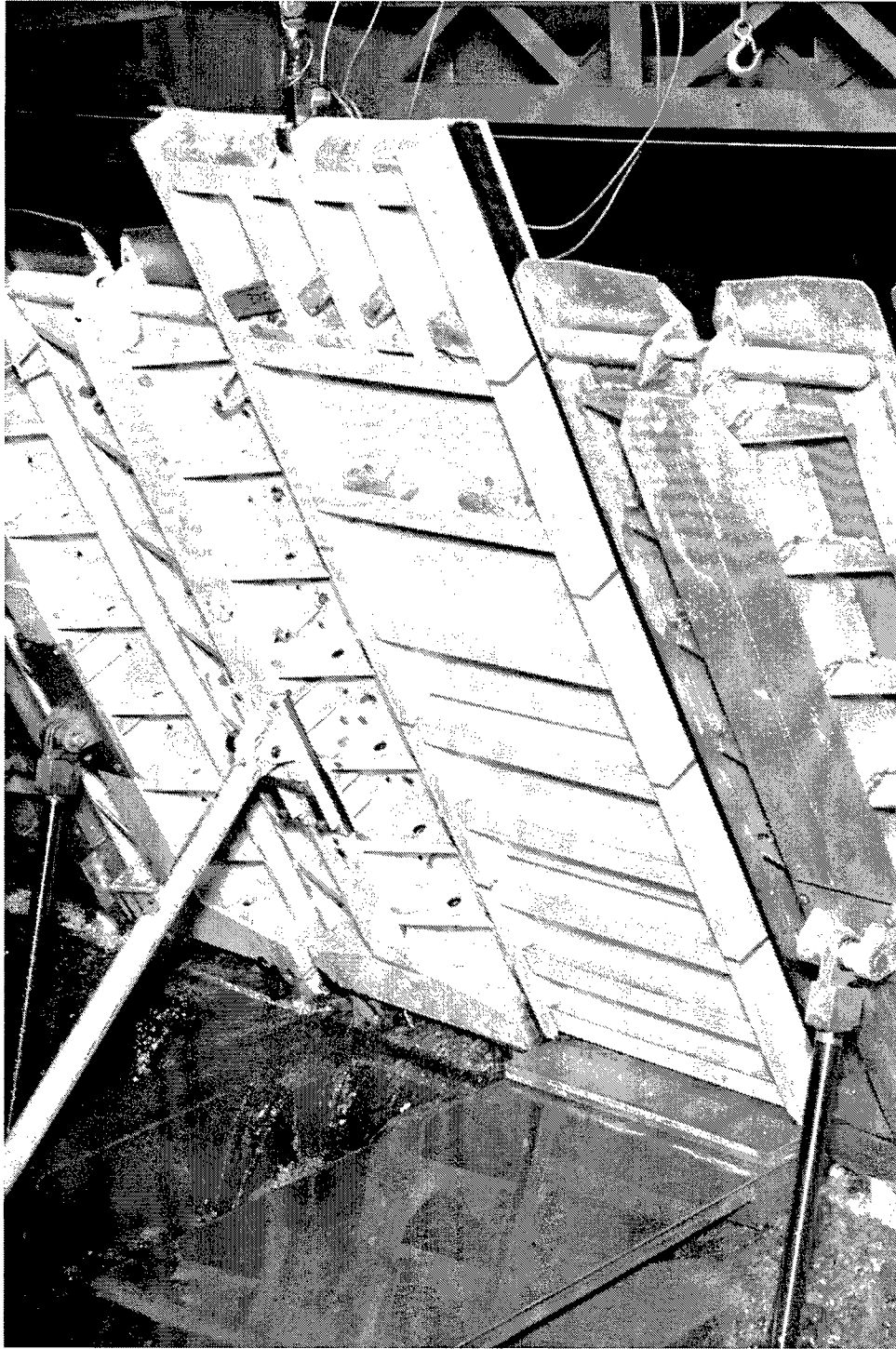

Figure 25. View from the walk, looking downstream at the blank submerged in the flow and seated on wicket gate #5. The blank is weighted with 68.32 lb of lead positioned in the upper three channels. Headwater 301; Tailwater 294; 7-ft differential



22294-043.jpg
Figure 26. View from the walk, looking upstream at the blank seated on wicket gate #5, showing the weights located in the top three channels. Dry bed photograph



Figure 27. View from the catwalk, looking upstream at the blank seated on wicket gate #5, showing the weights located in the top three channels. Dry bed photograph

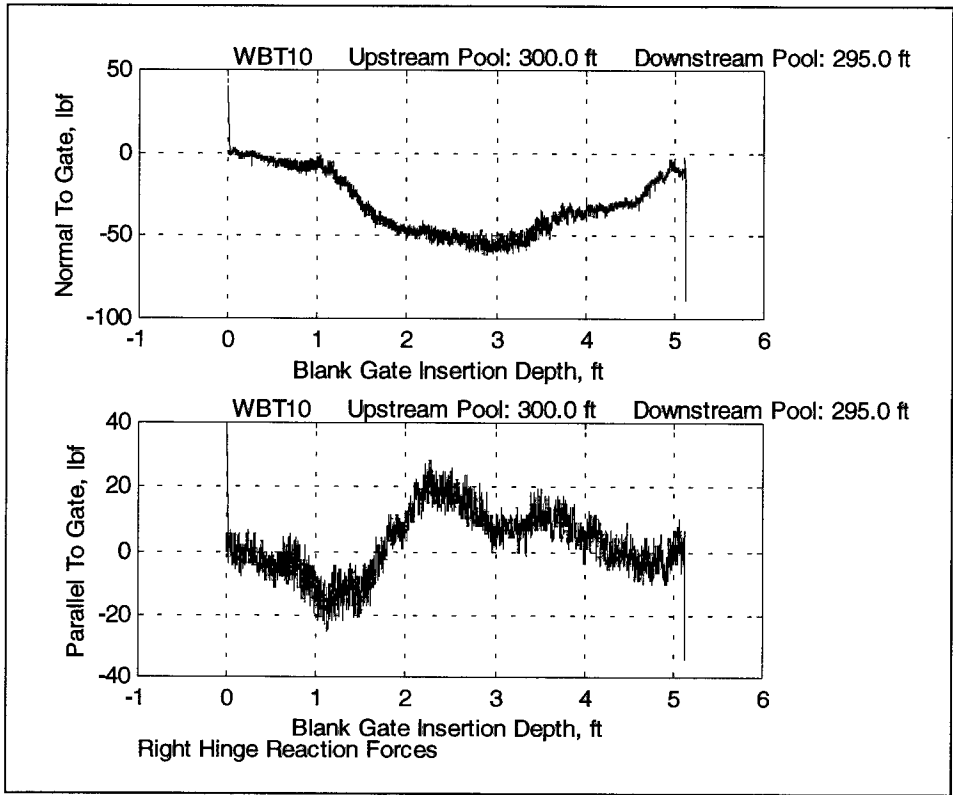

Figure 28. Right hinge reactions for OLMWBT1

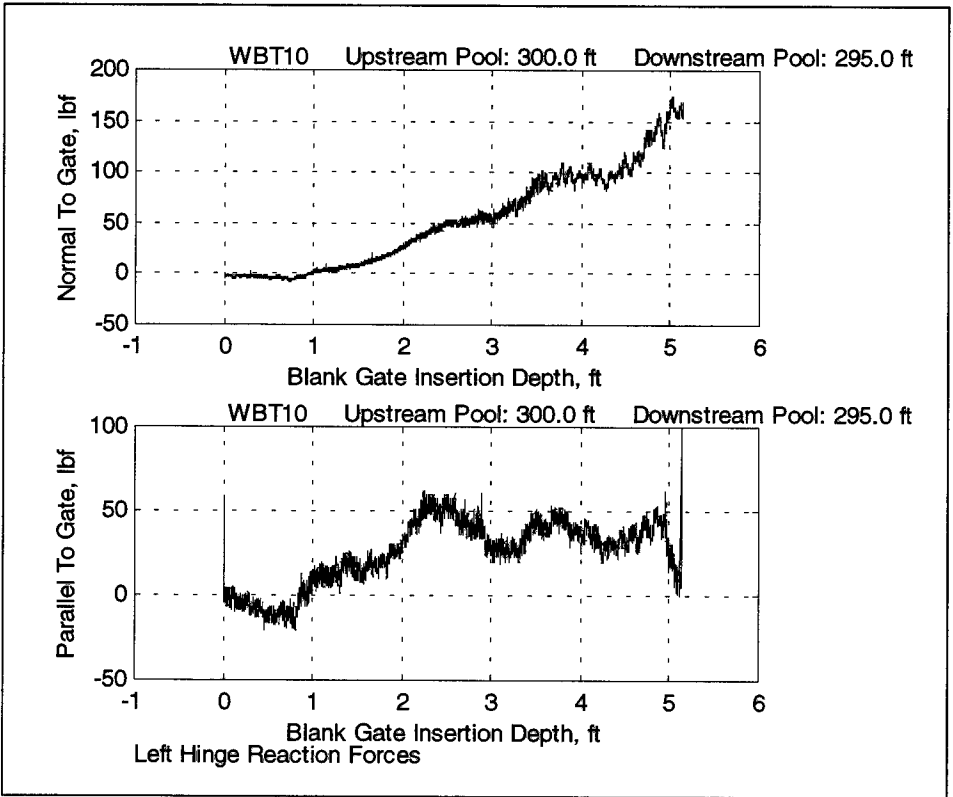

Figure 29. Left hinge reactions for test OLMWBT1

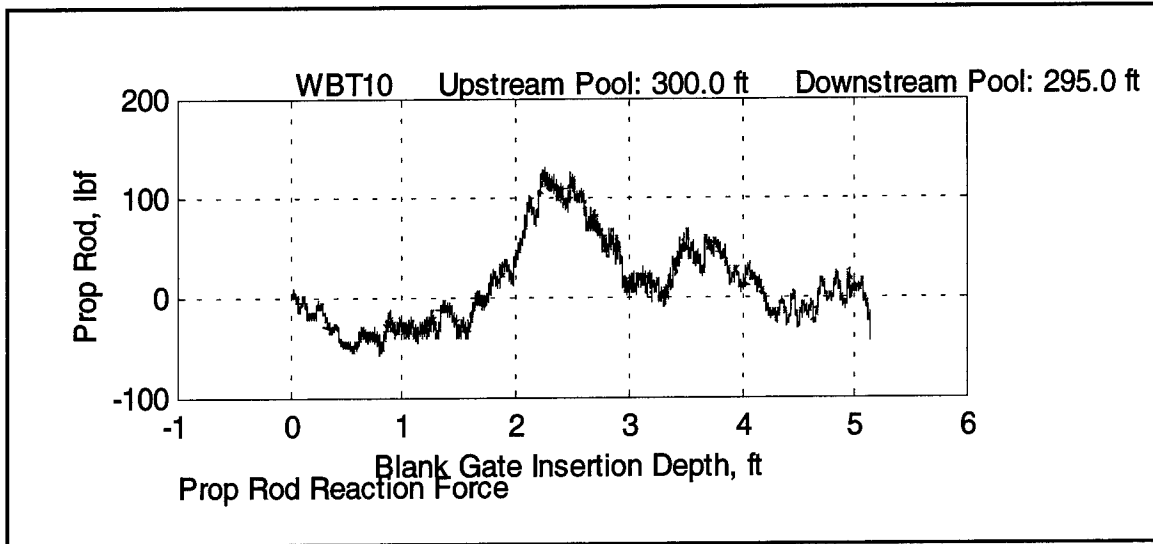

Figure 30. Prop rod force for test OLMWBT1

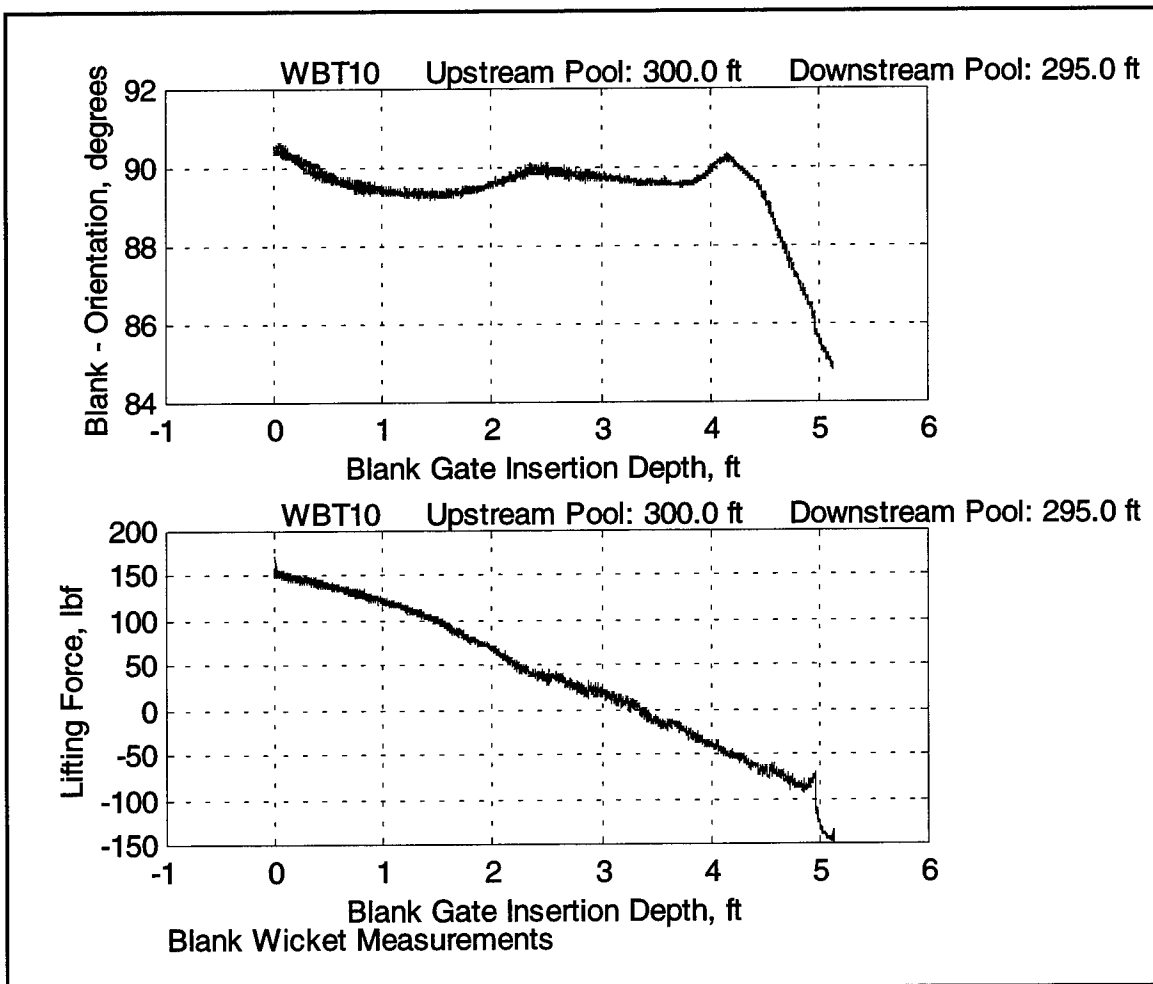

Figure 31. Lifting force and blank orientation for test OLMWBT1

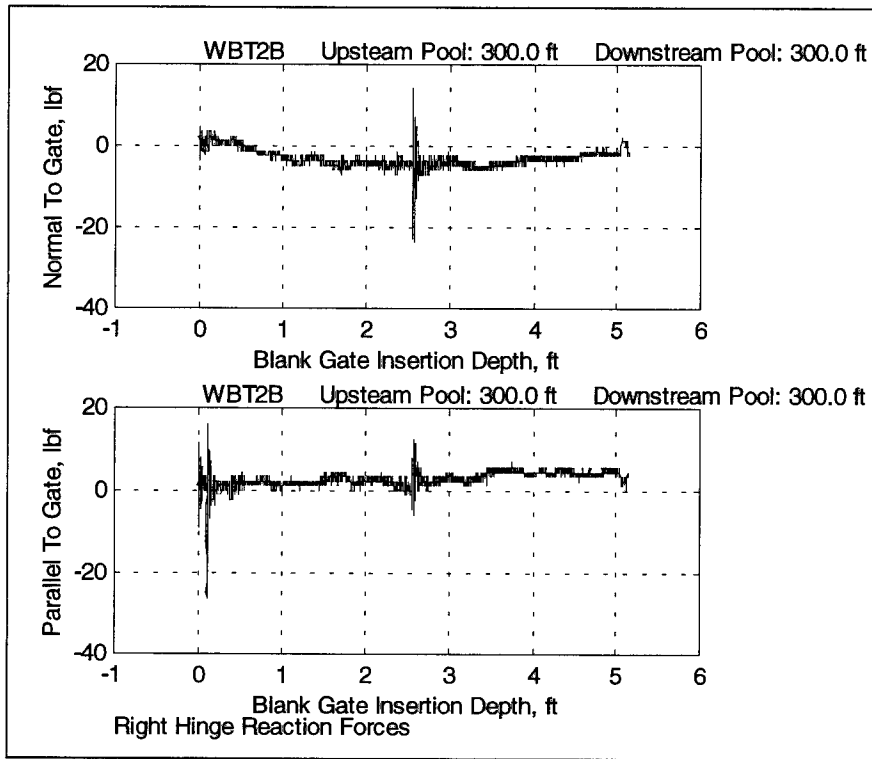

Figure 32. Right hinge reactions for OLMW2B

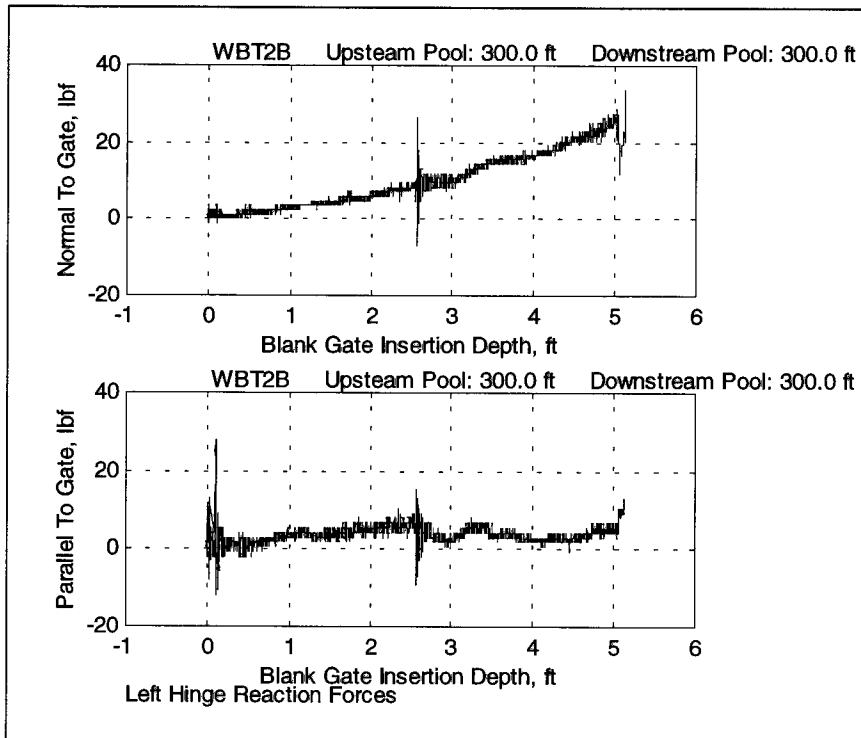

Figure 33. Left hinge reactions for test OLMWBT2B

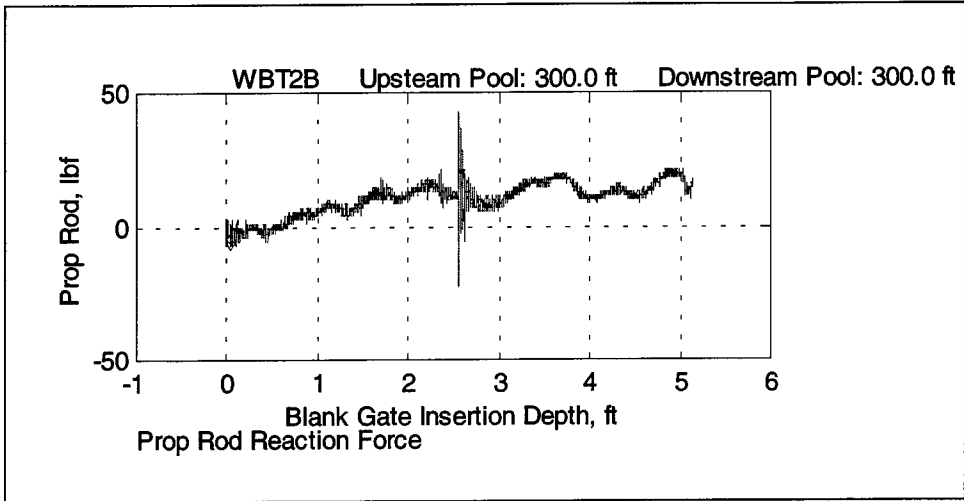

Figure 34. Prop rod force for test OLMWB2B

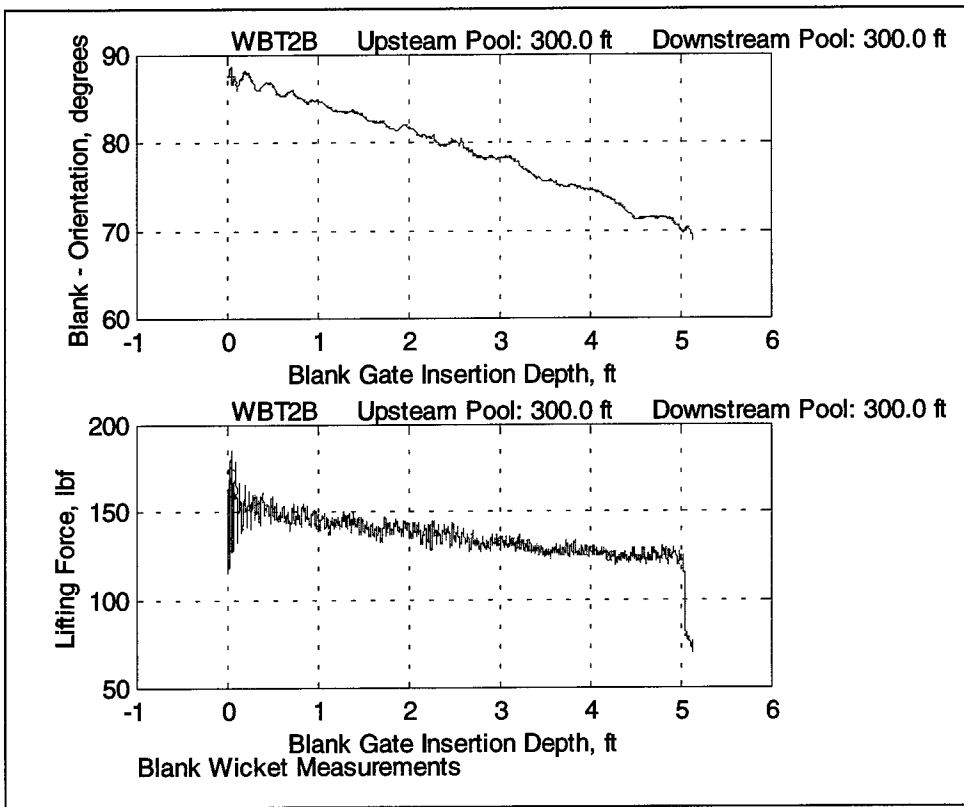

Figure 35. Lifting force and blank orientation for test OLMWBT2B

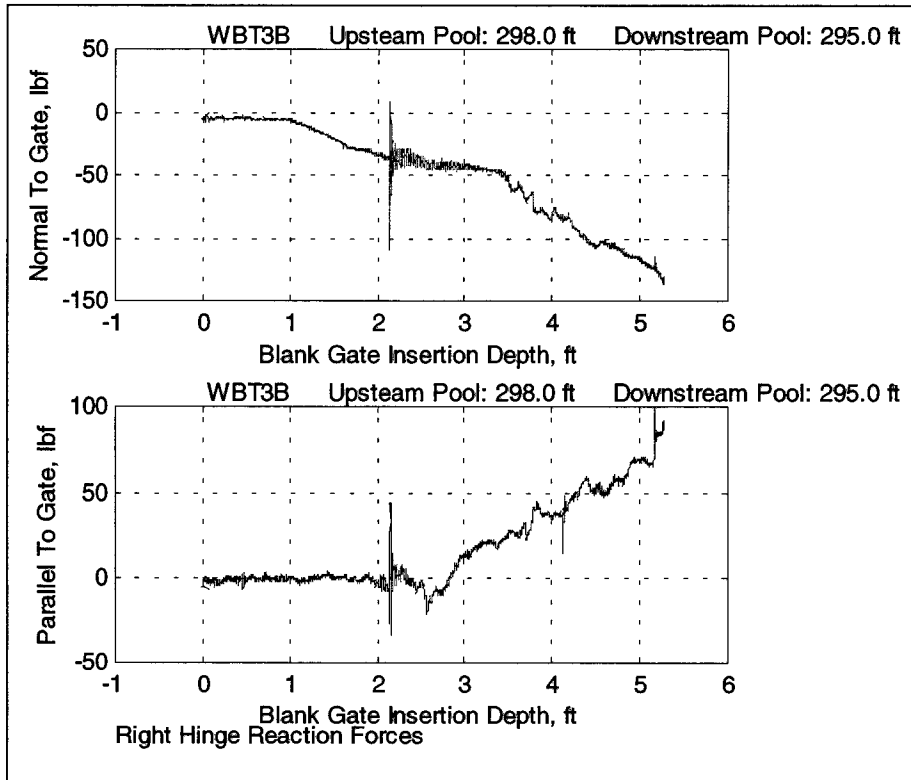

Figure 36. Right hinge reactions for OLMWBT3B

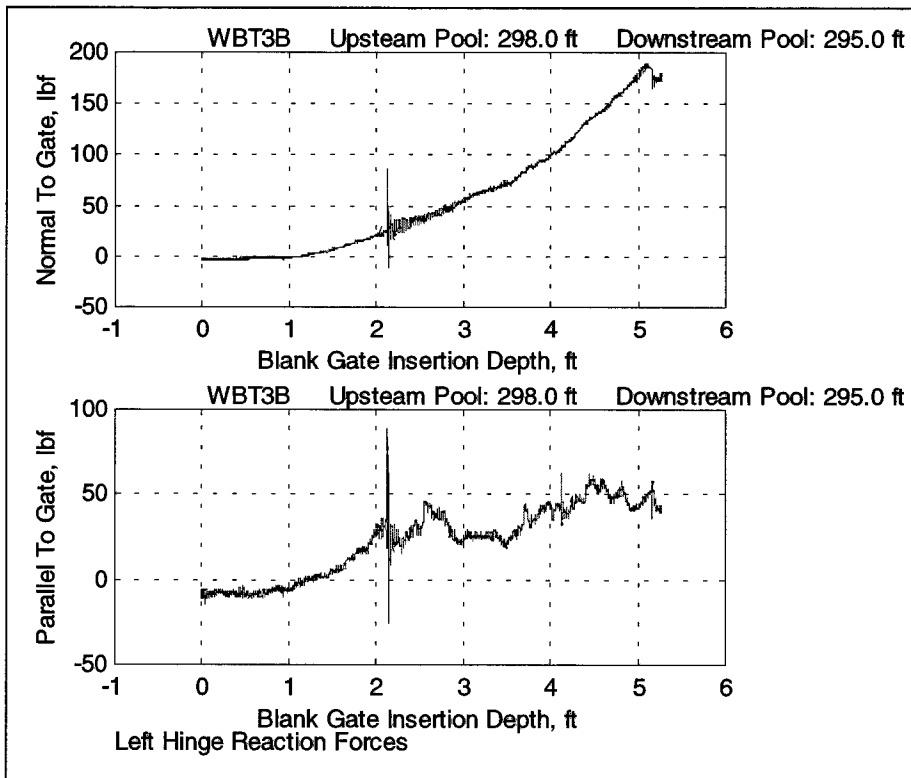

Figure 37. Left hinge reactions for OLMWBT3B

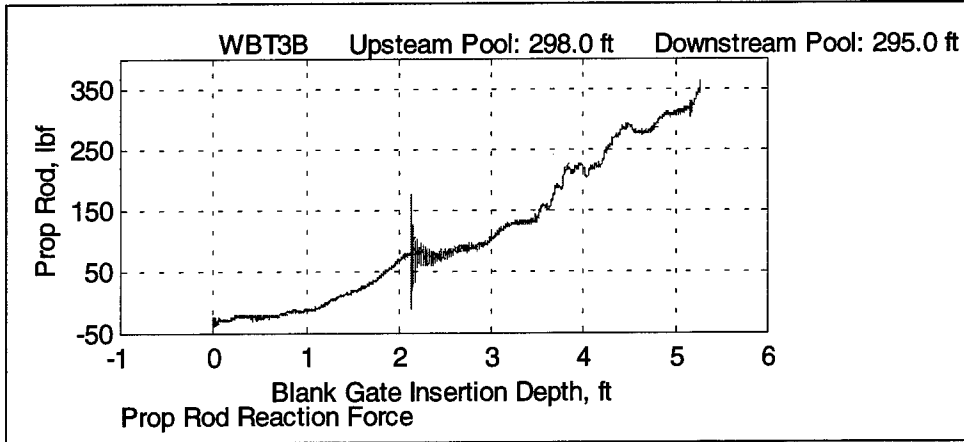

Figure 38. Prop rod force for test OLMWBT3B

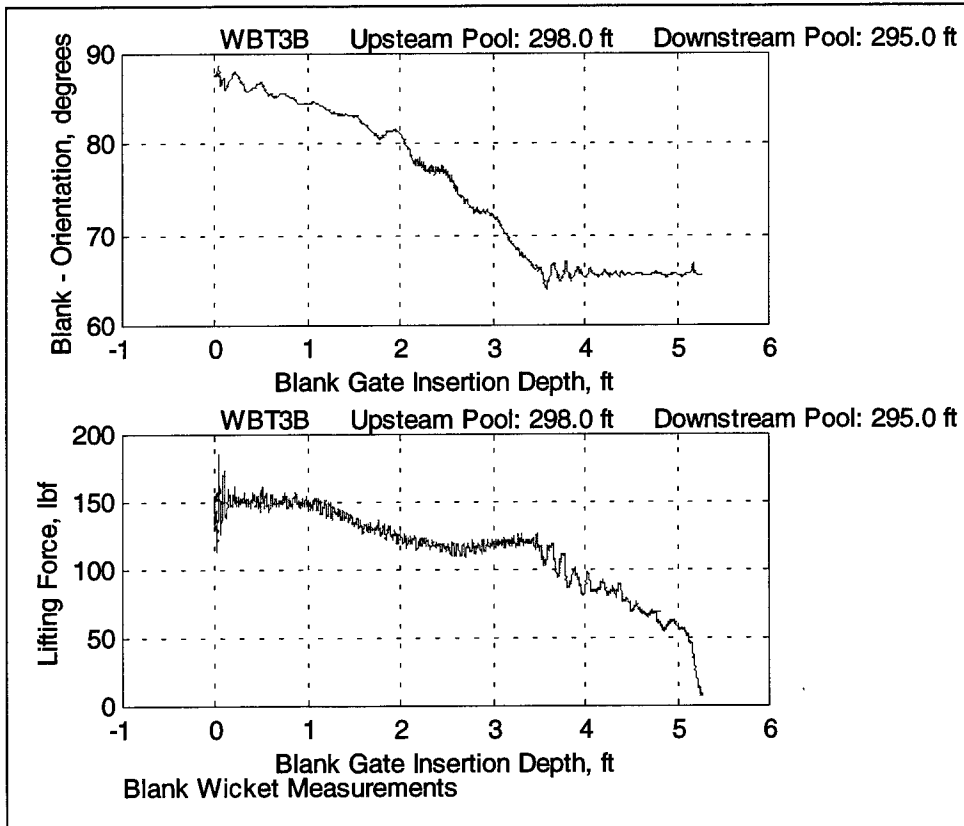

Figure 39. Lifting force and blank orientation for test OLMWBT3B

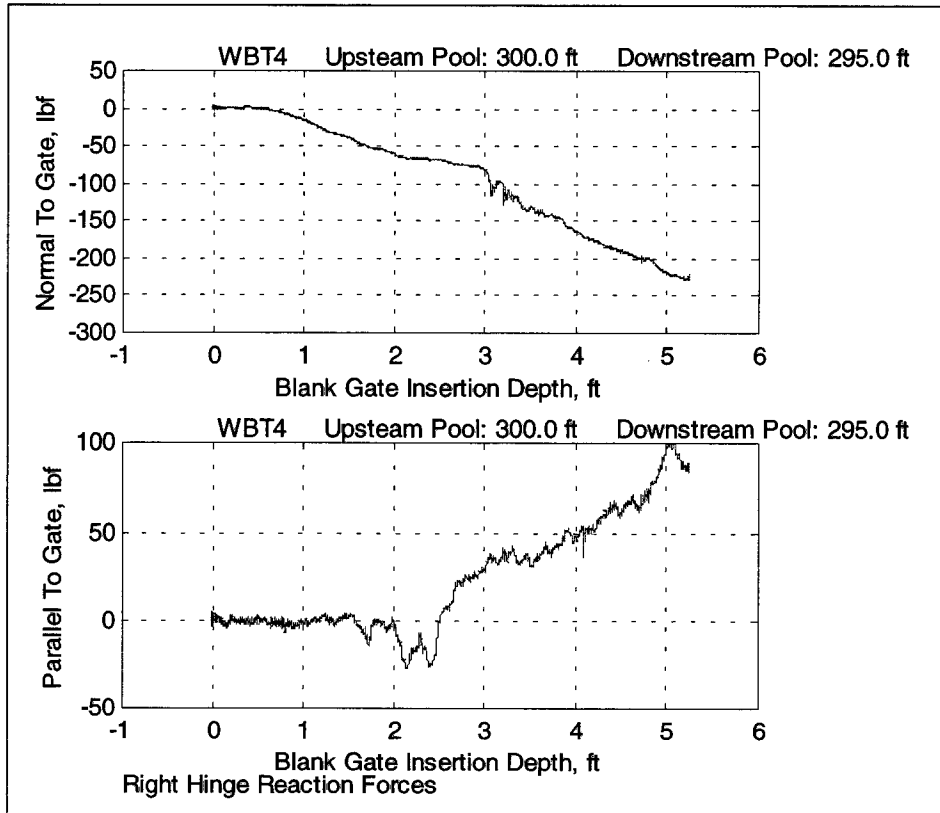

Figure 40. Right hinge reactions for OLMWBT4

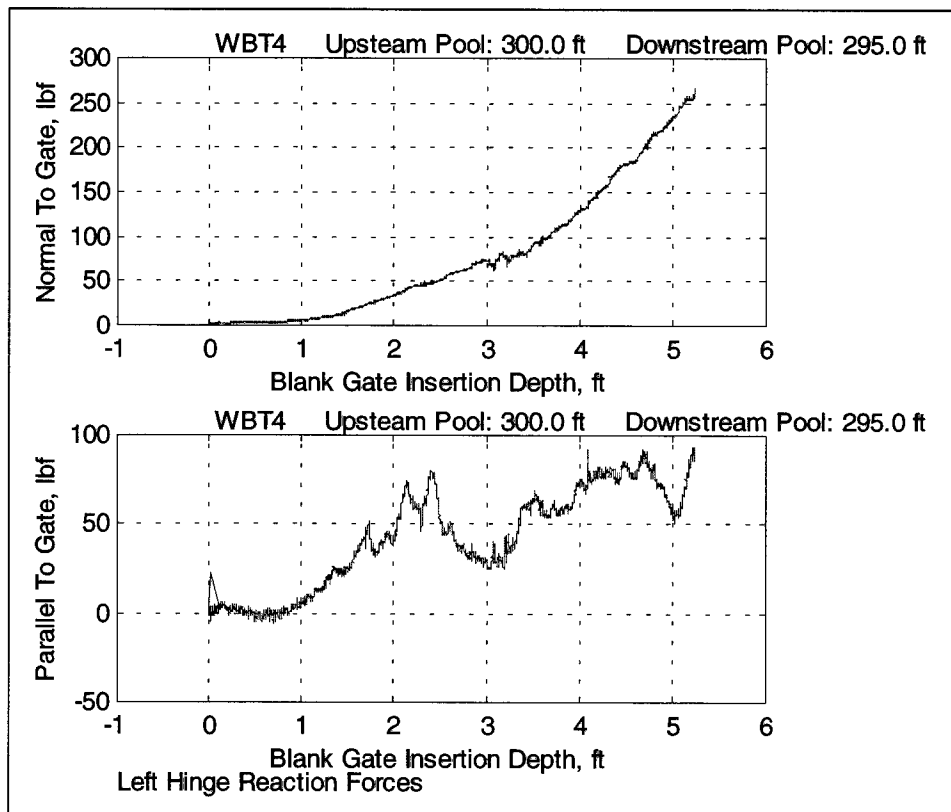

Figure 41. Left hinge reactions for OLMWBT4

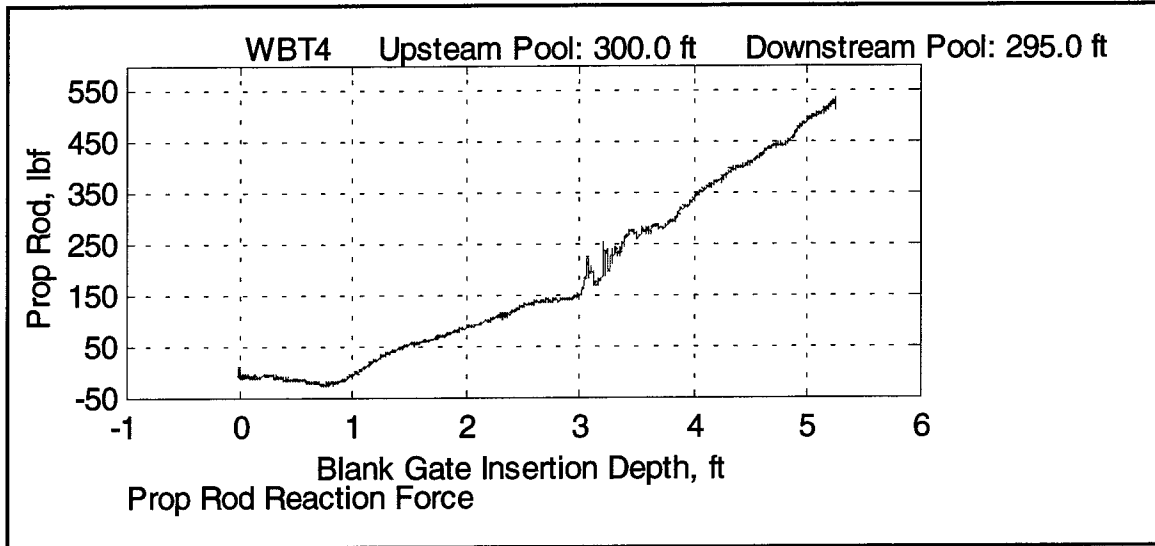

Figure 42. Prop rod force for test OLMWBT4

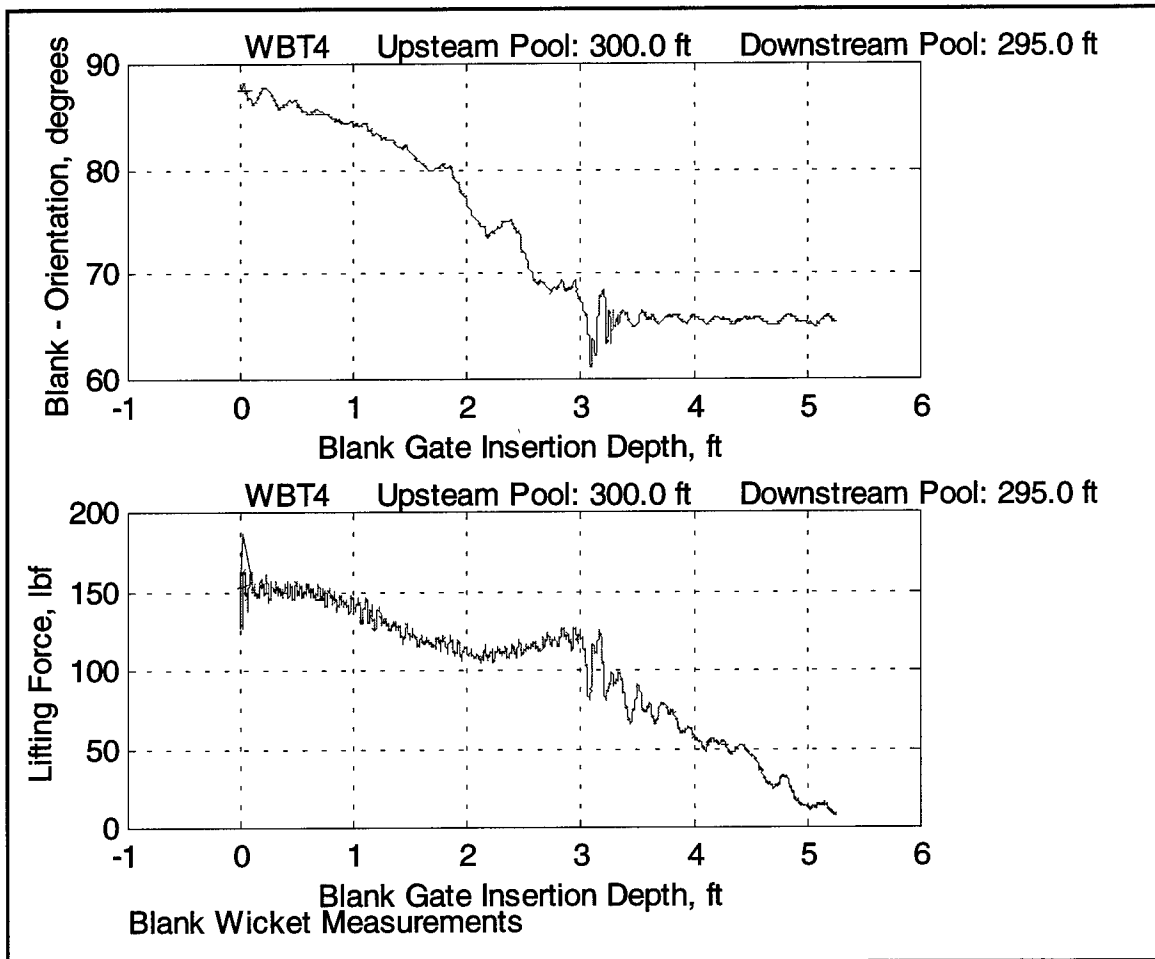

Figure 43. Lifting force and blank orientation for test OLMWBT4

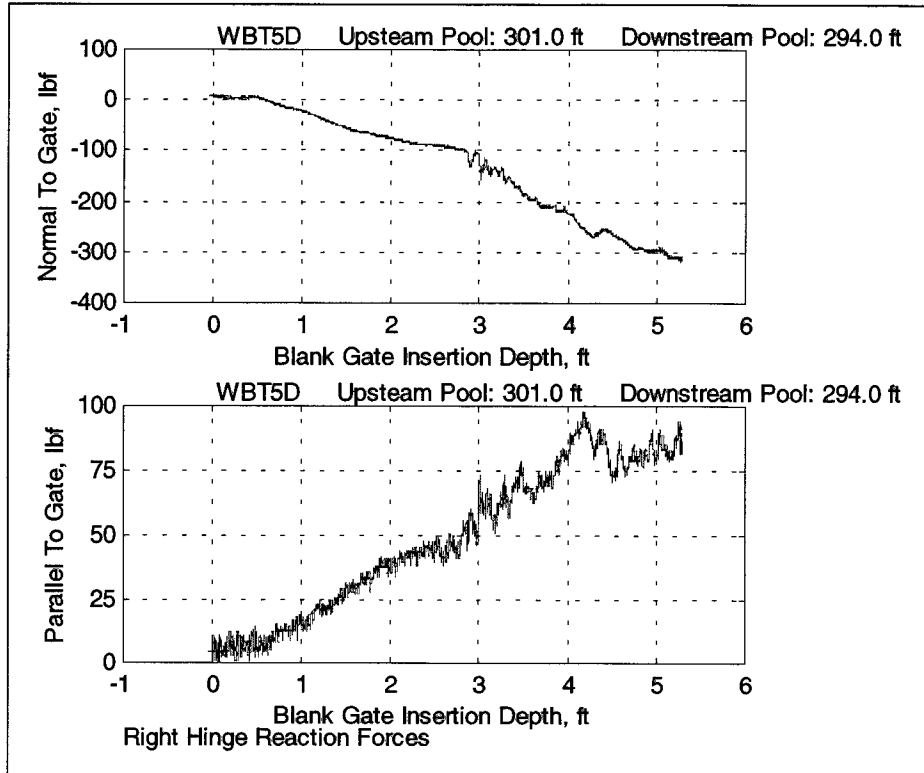

Figure 44. Right hinge reactions for OLMWBT5D

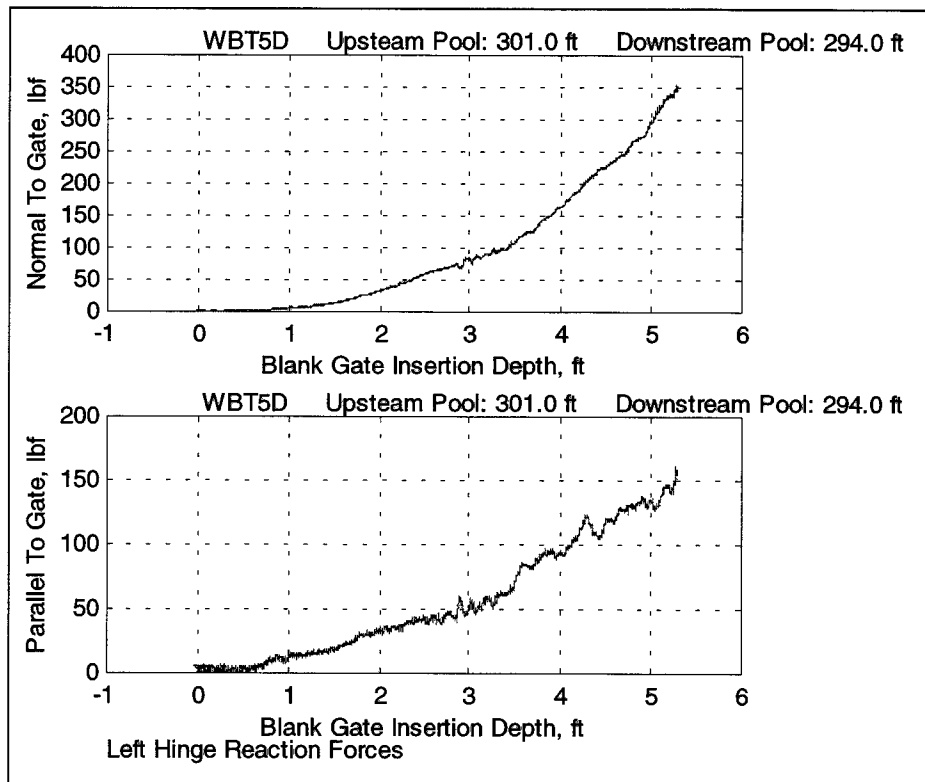

Figure 45. Left hinge reactions for OLMWBT5D

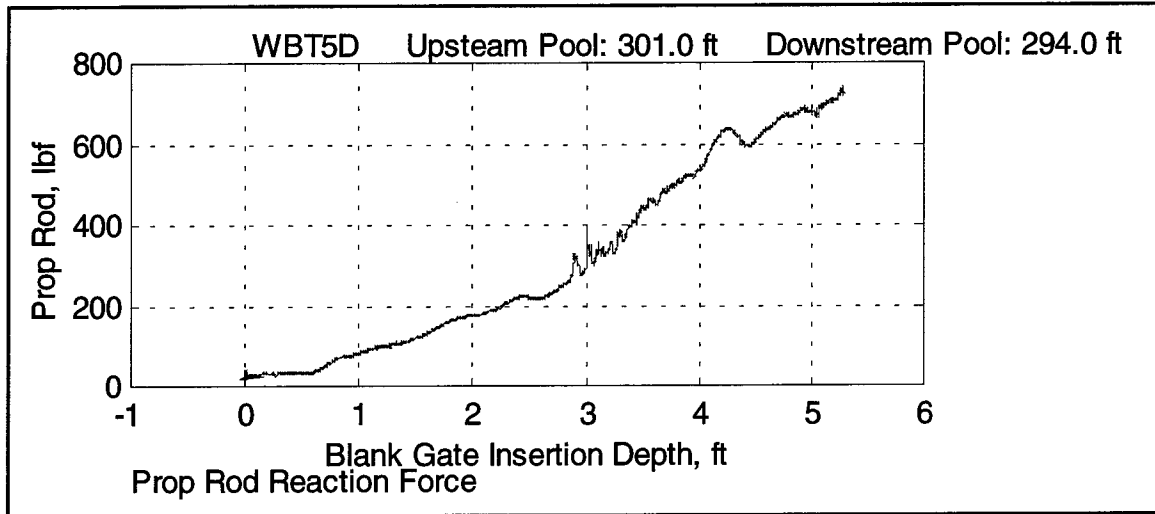

Figure 46. Prop rod force for test OLMWBT5D

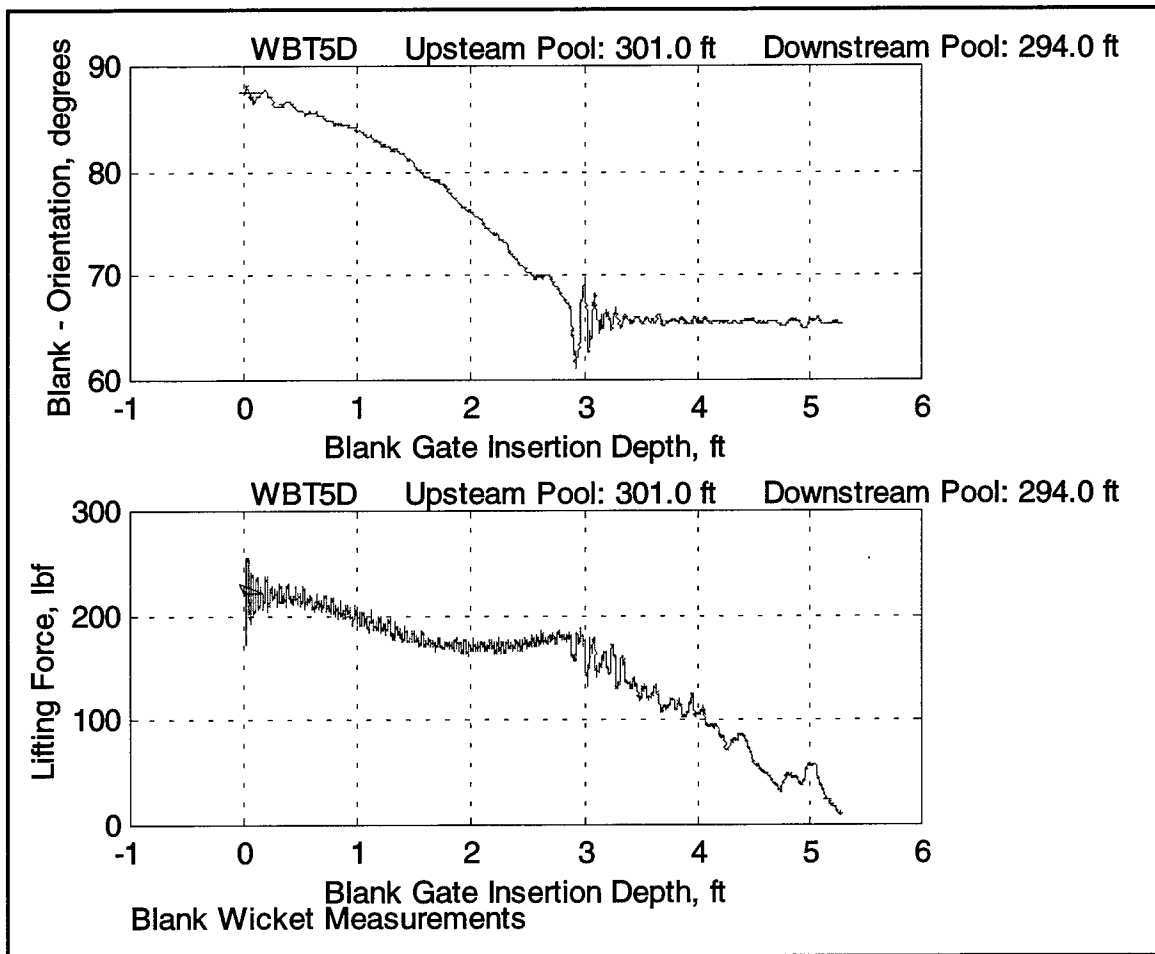

Figure 47. Lifting force and blank orientation for test OLMWBT5D

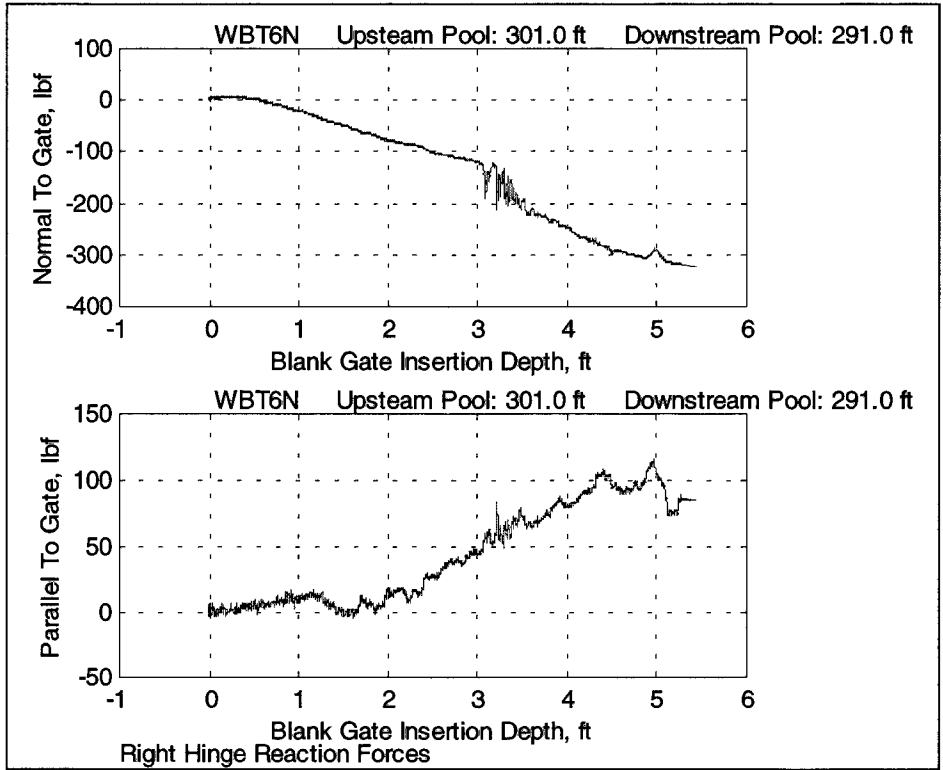

Figure 48. Right hinge reactions for test OLMWBT6N

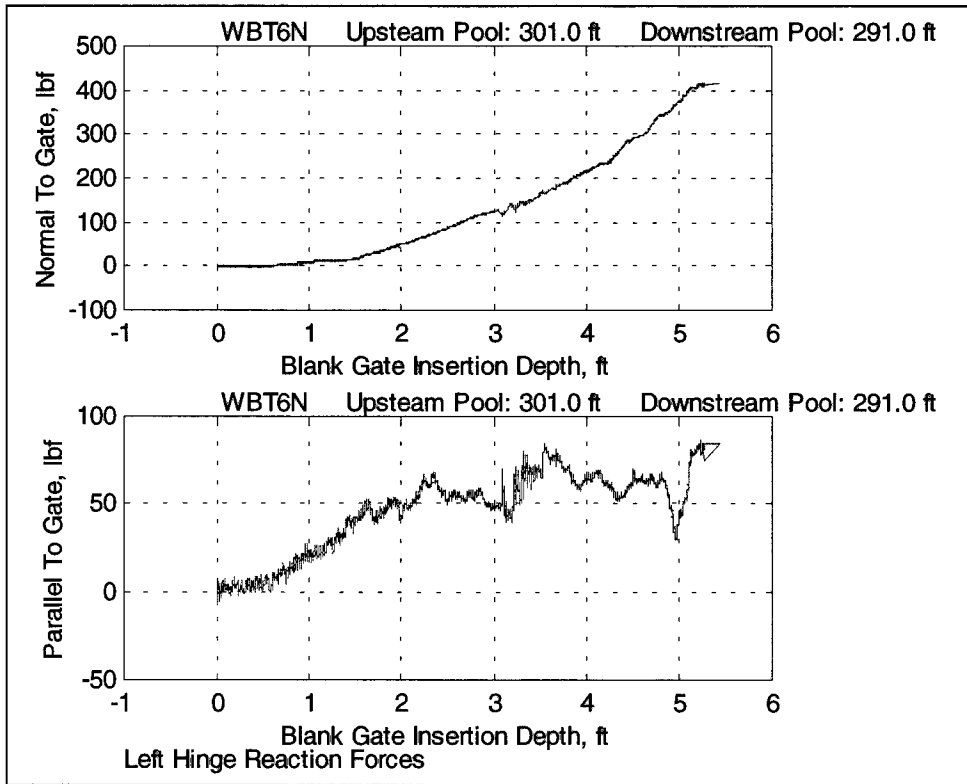

Figure 49. Left hinge reactions for OLMWBT6N

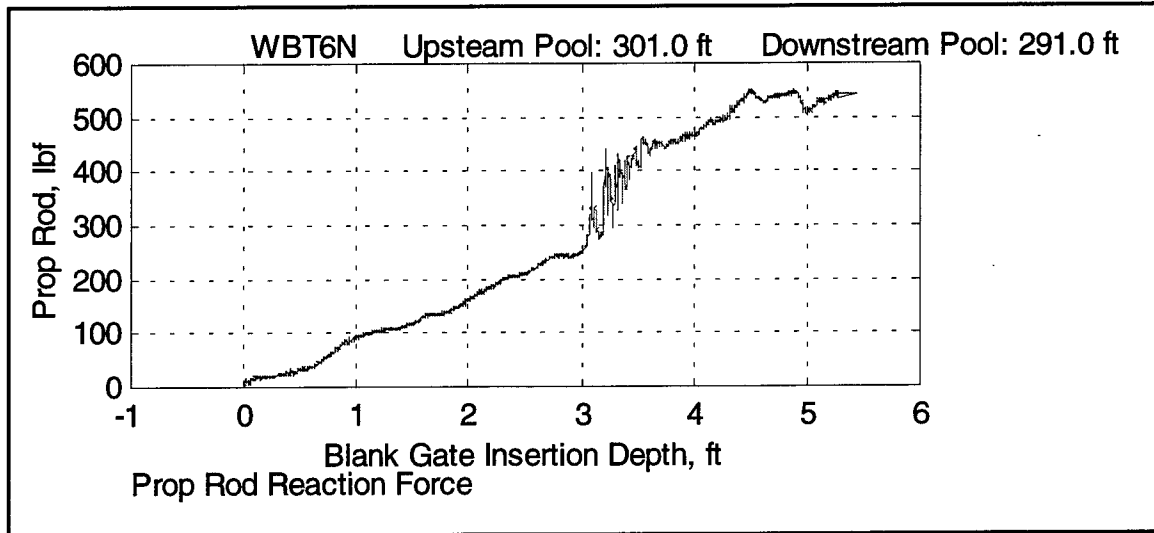

Figure 50. Prop rod force for test OLMWBT6N

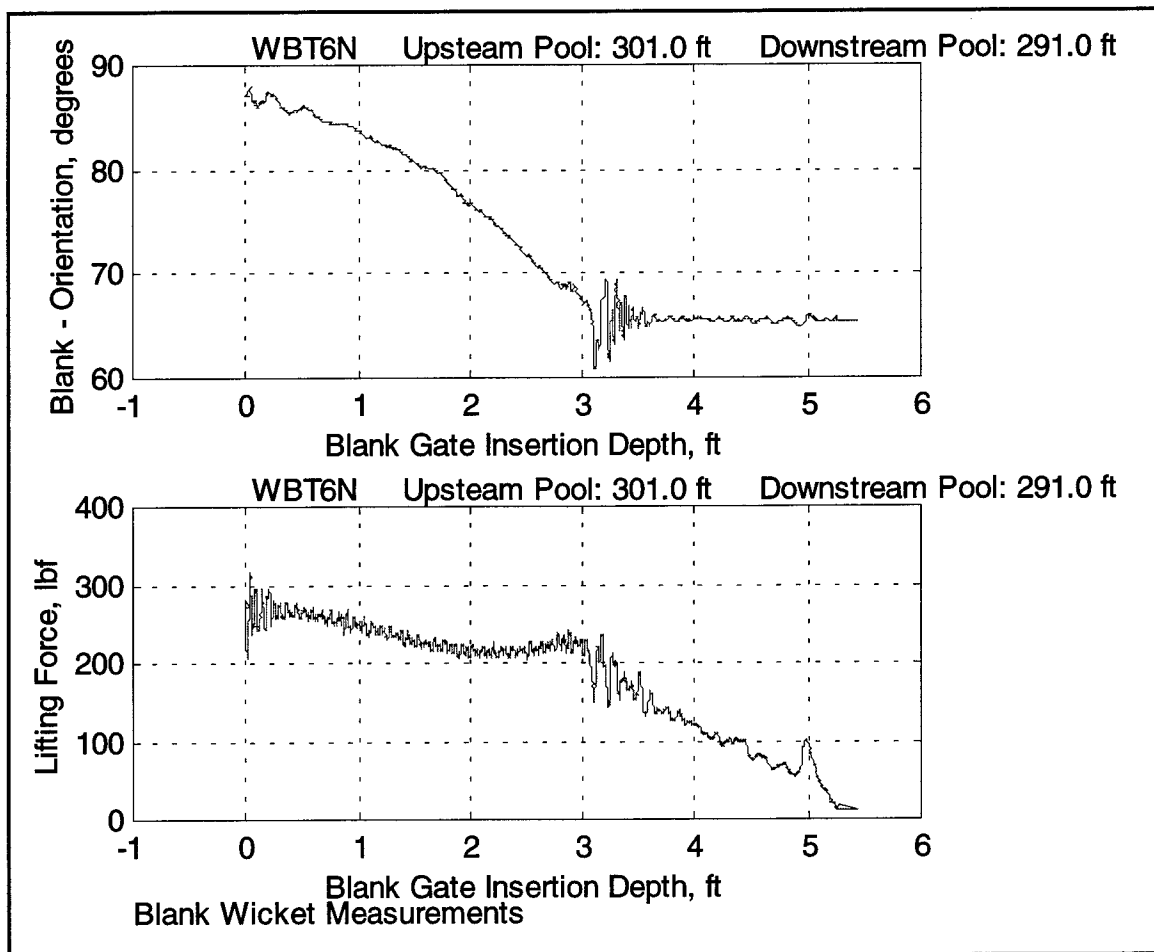

Figure 51. Lifting force and blank orientation for test OLMWBT6N

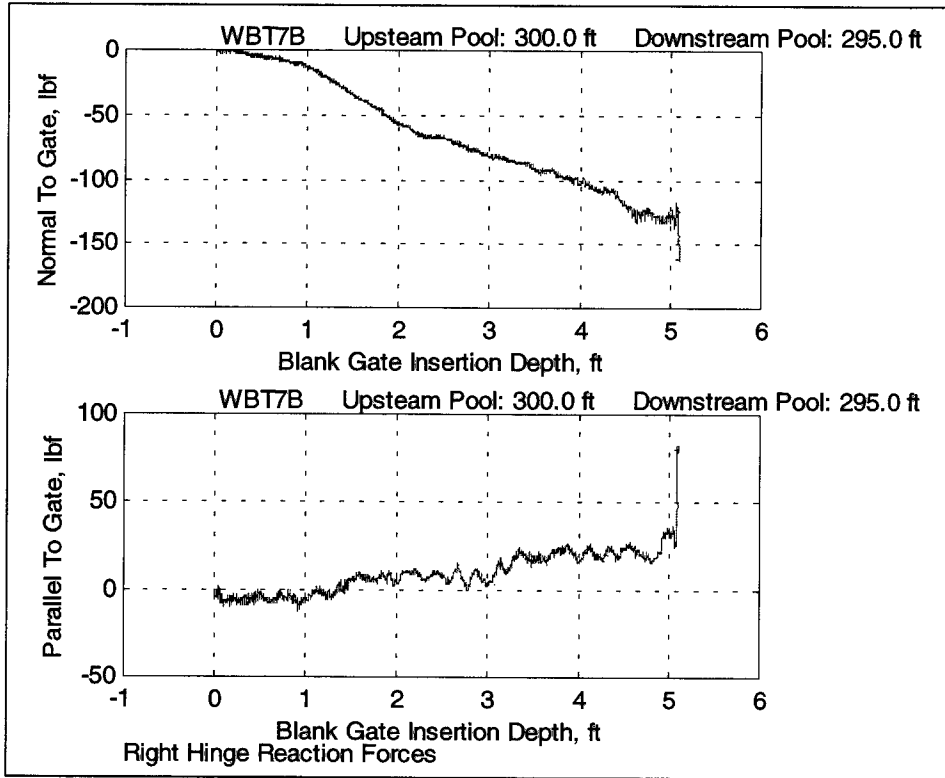

Figure 52. Right hinge reactions for OLMWBT7B

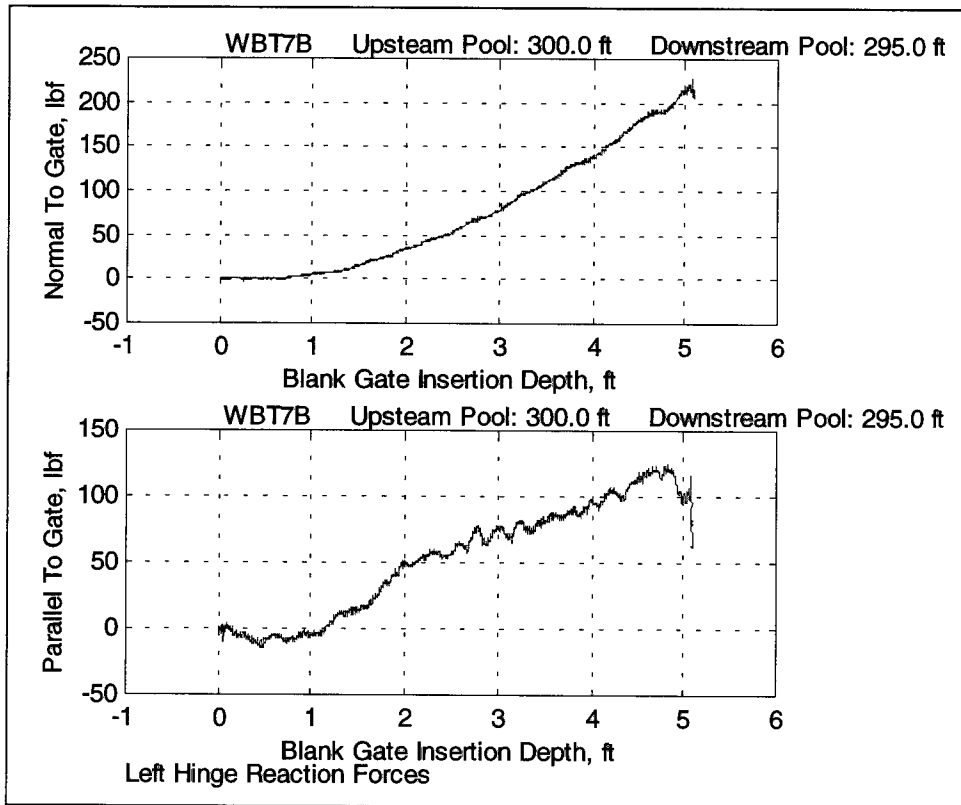

Figure 53. Left hinge reactions for OLMWBT7B

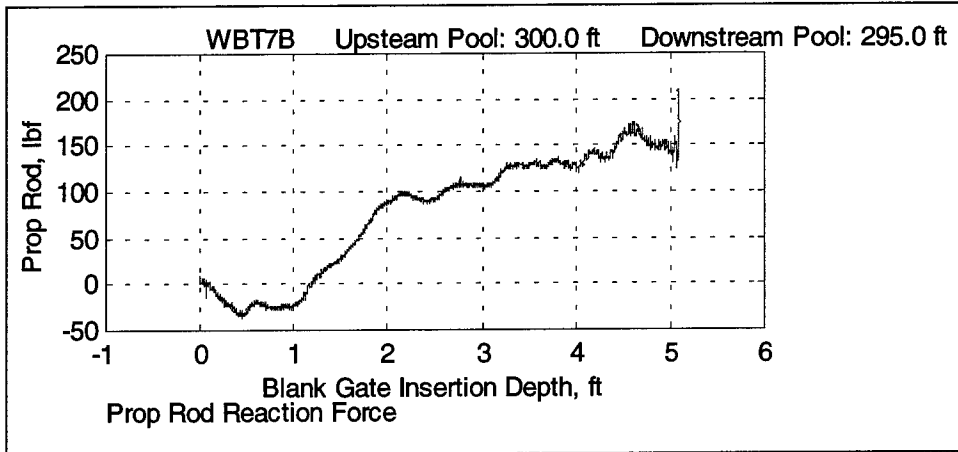

Figure 54. Prop rod force for test OLMWB7B

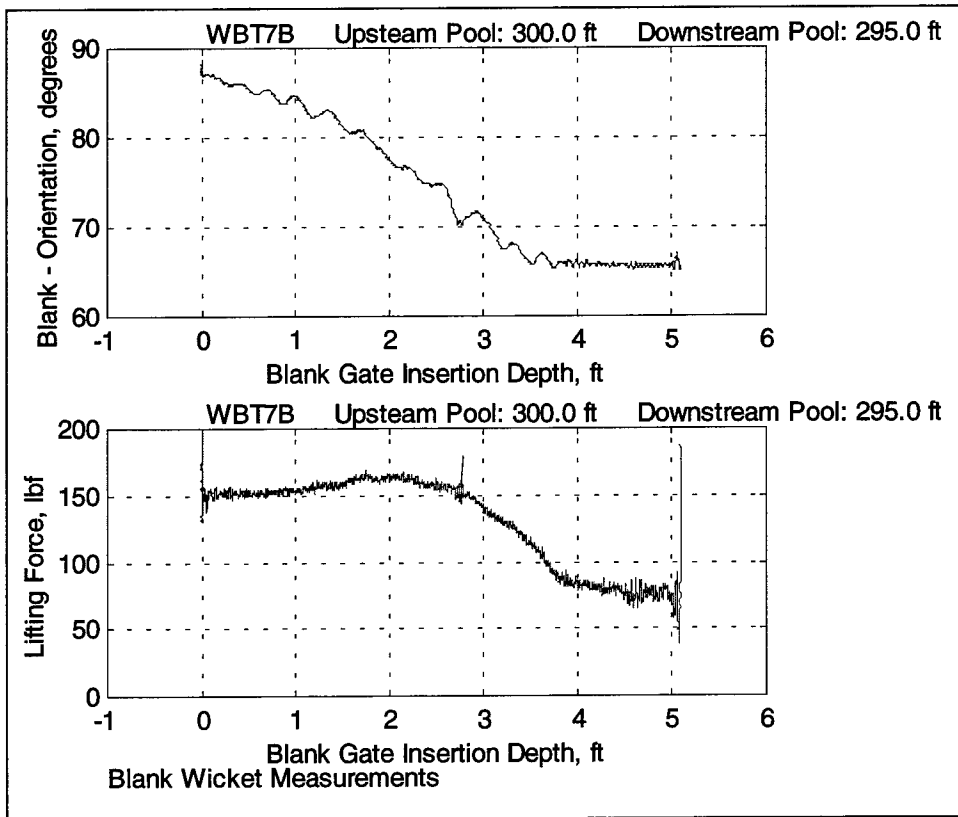

Figure 55. Lifting force and blank orientation for test OLMWB7B

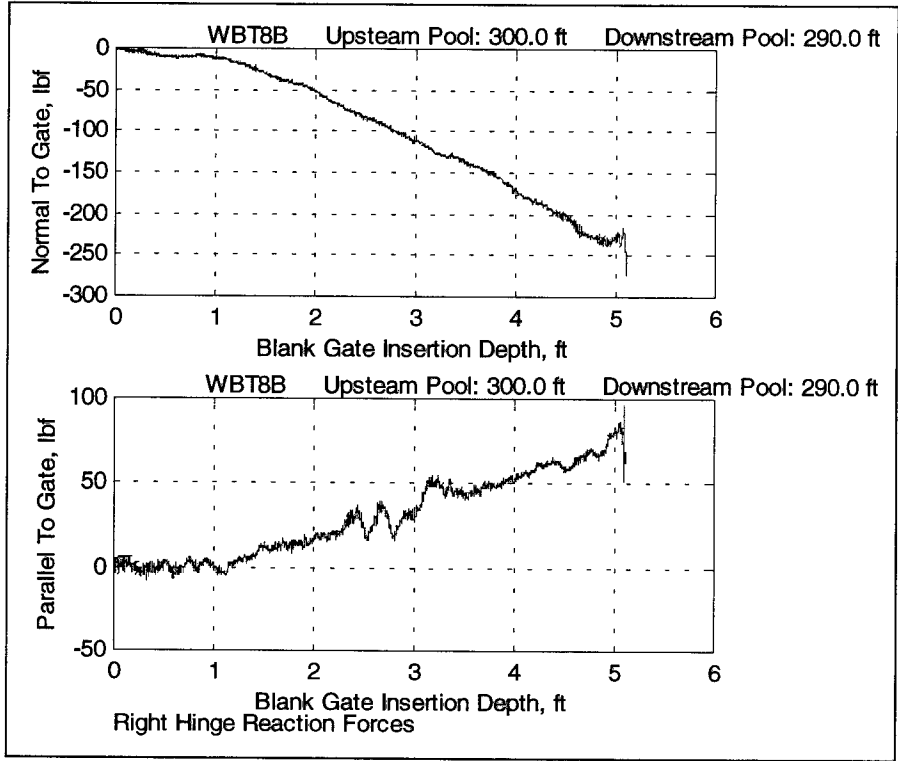

Figure 56. Right hinge reactions for OLMWBT8B

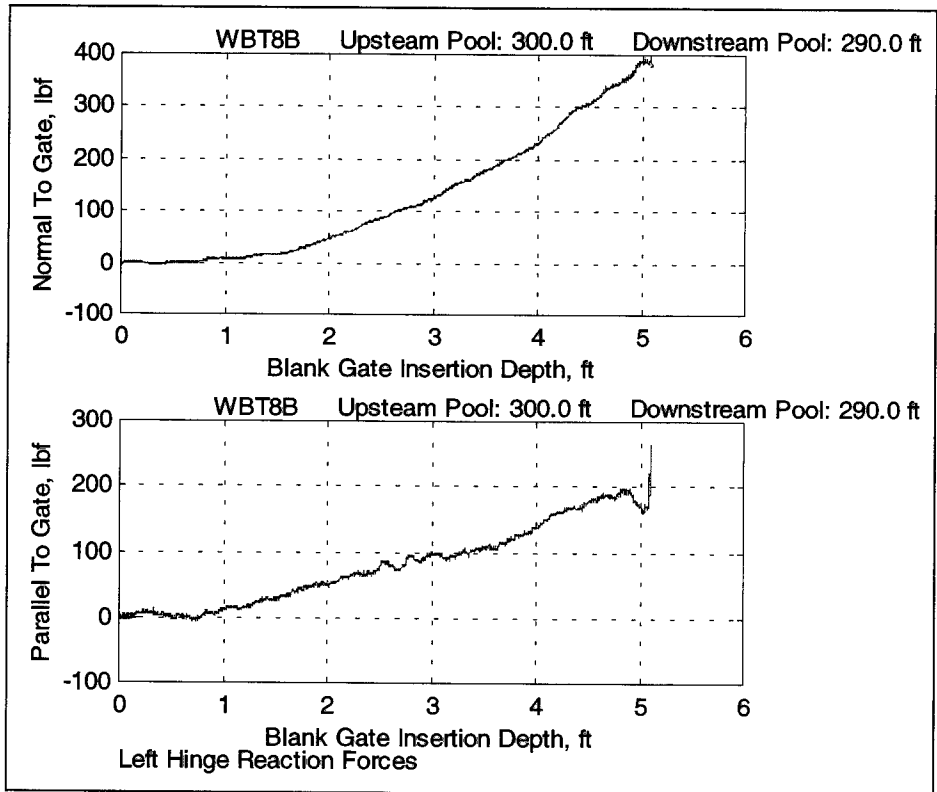

Figure 57. Left hinge reactions for OLMWBT8B

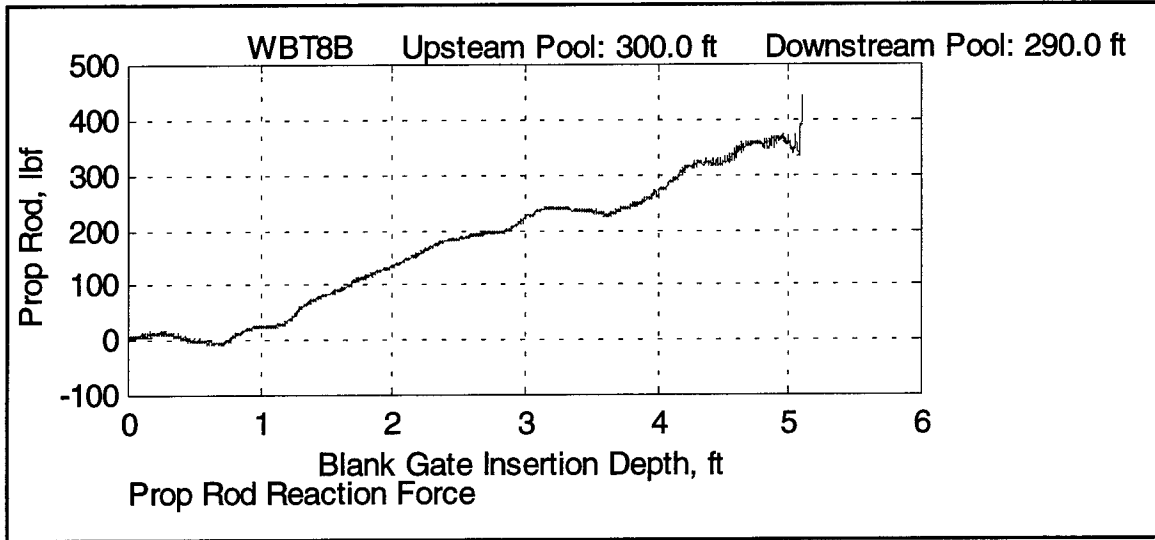

Figure 58. Prop rod force for test OLMWBT8B

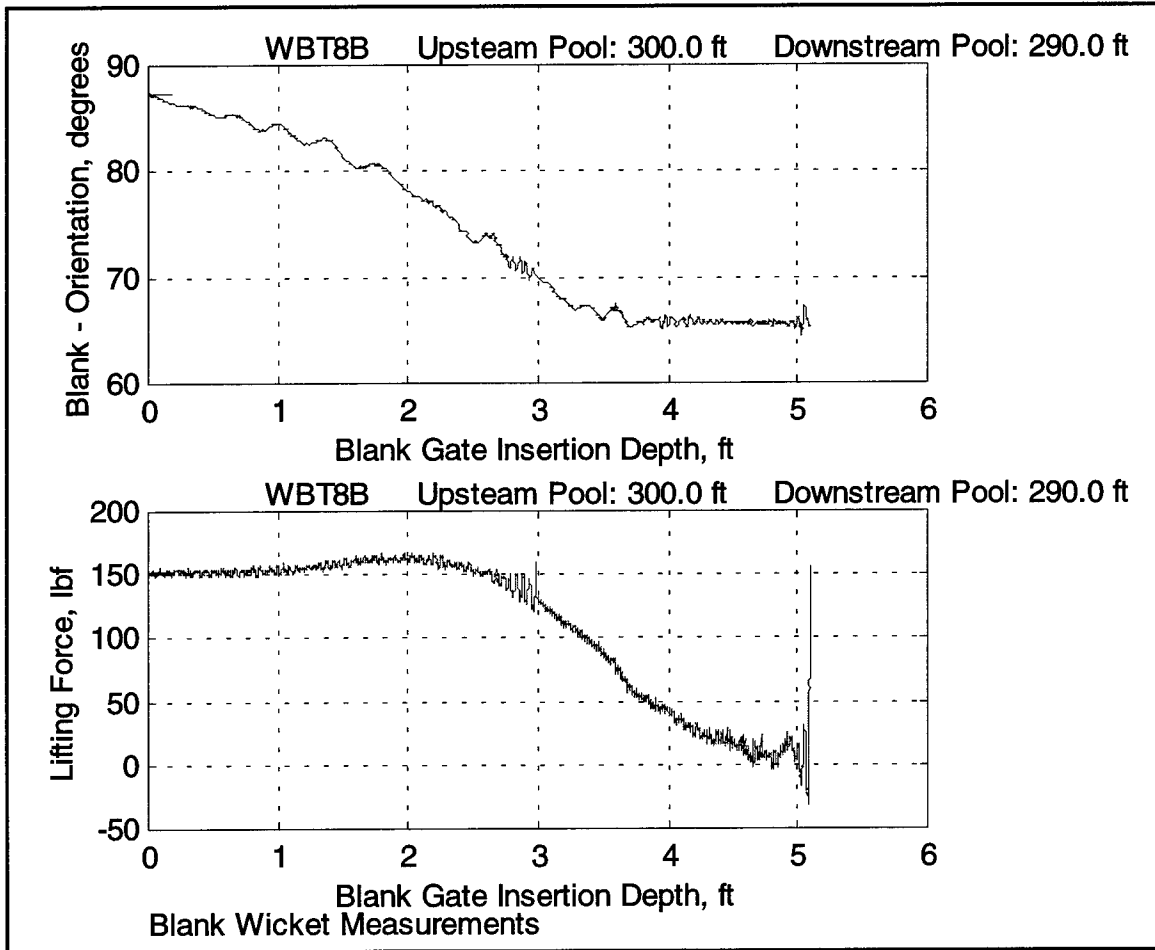

Figure 59. Lifting force and blank orientation for test OLMWBT8B

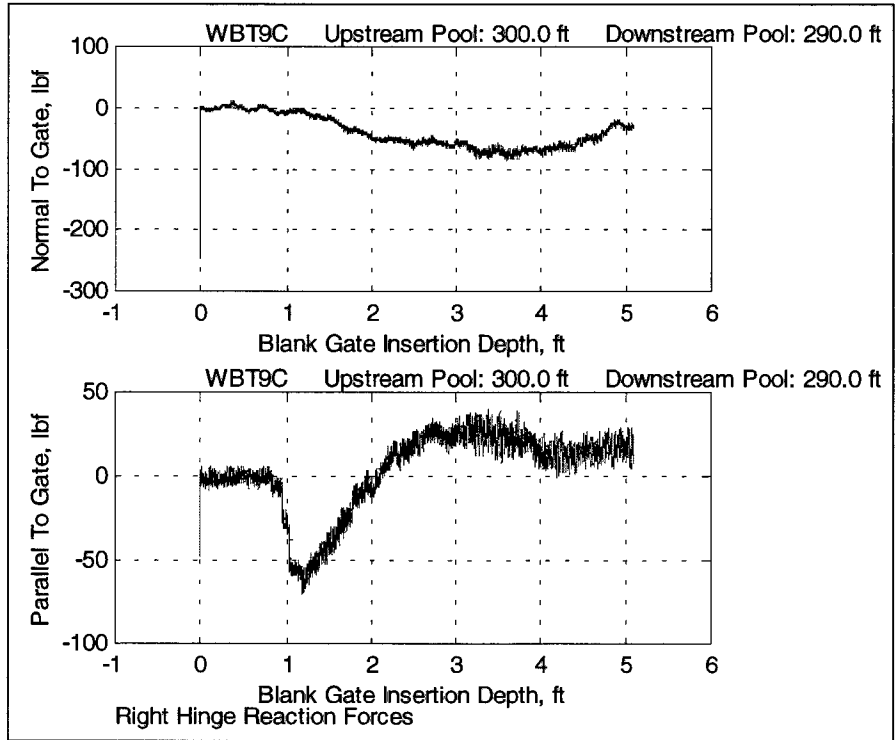

Figure 60. Right hinge reactions for OLMWBT9C

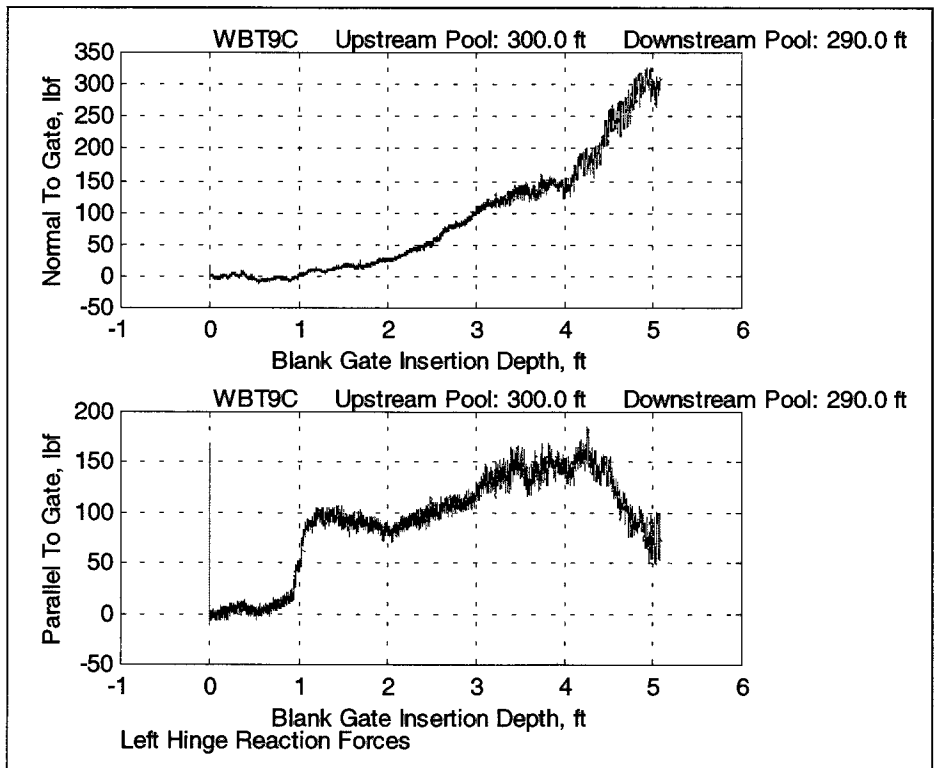

Figure 61. Left hinge reactions for OLMWBT9C

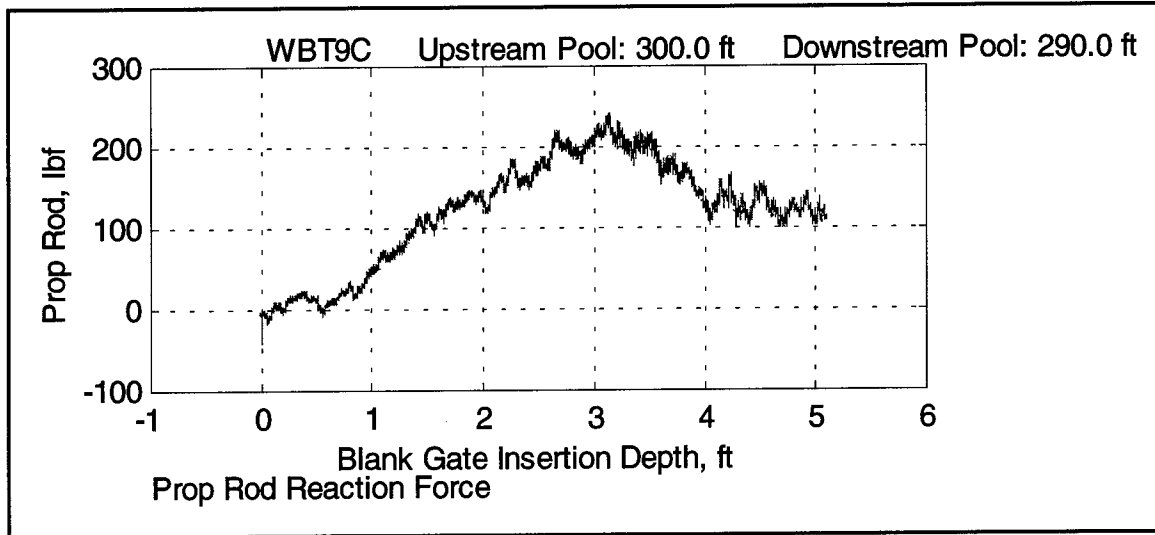

Figure 62. Prop rod force for test OLMWBT9C

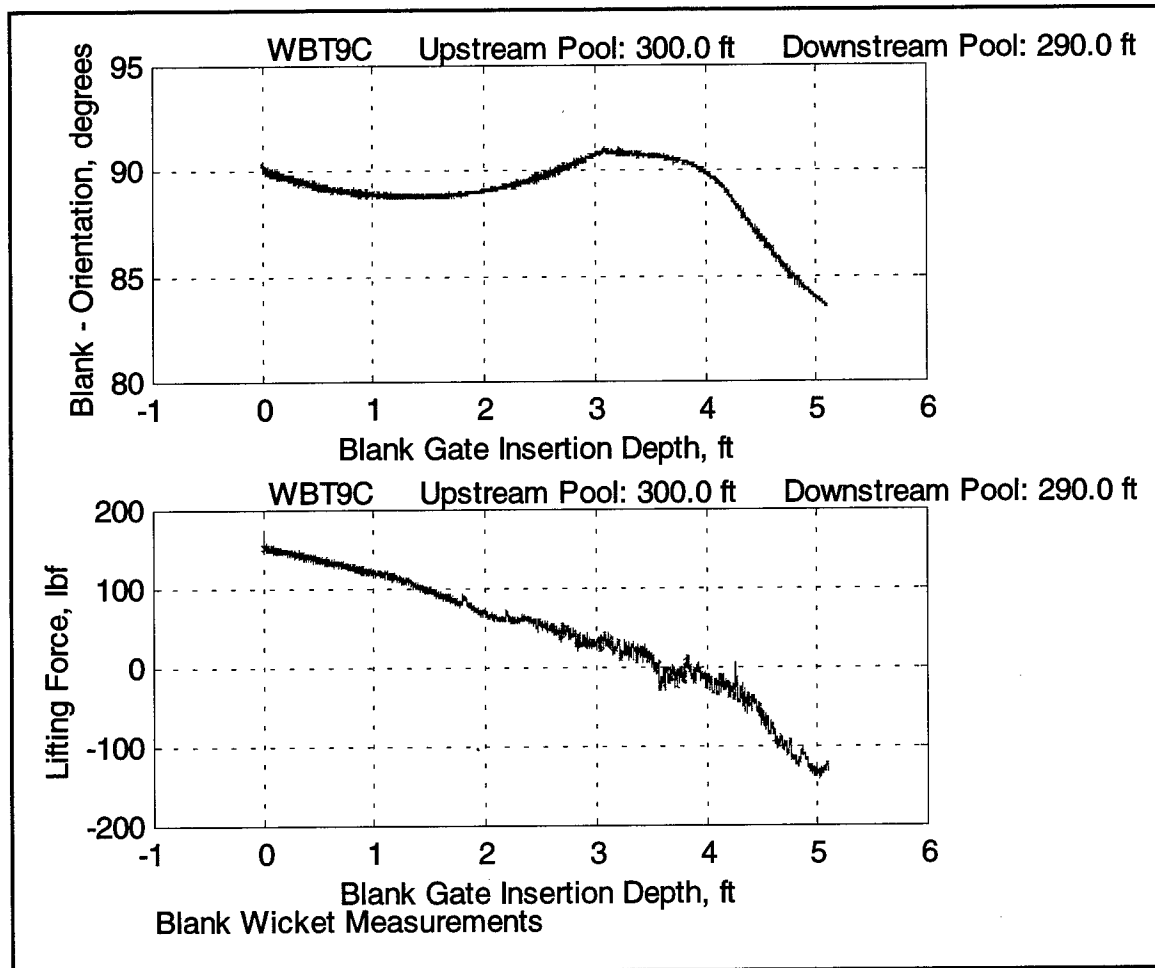
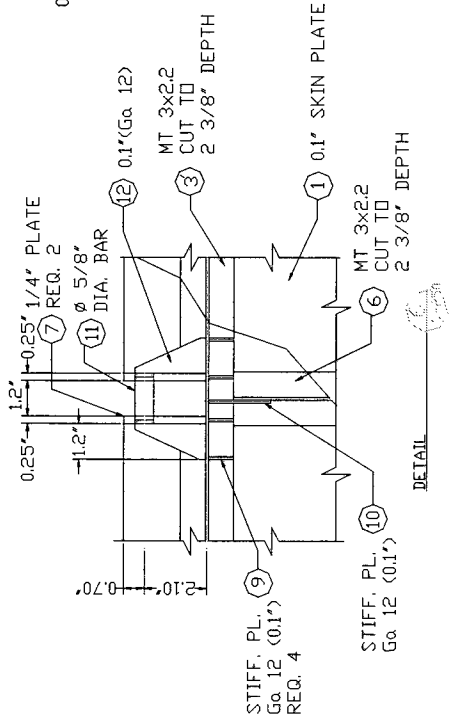

Figure 63. Lifting force and blank orientation for test OLMWBT9C

Appendix A

Show Drawings

CL BLANK



DETAIL

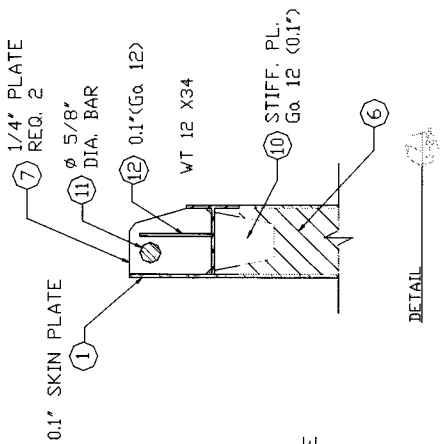

DETAIL

Ø 13/32" DIA. HOLE
0.15" THK. PLATE (13)

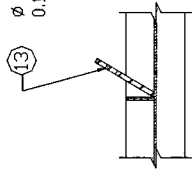

SECTION

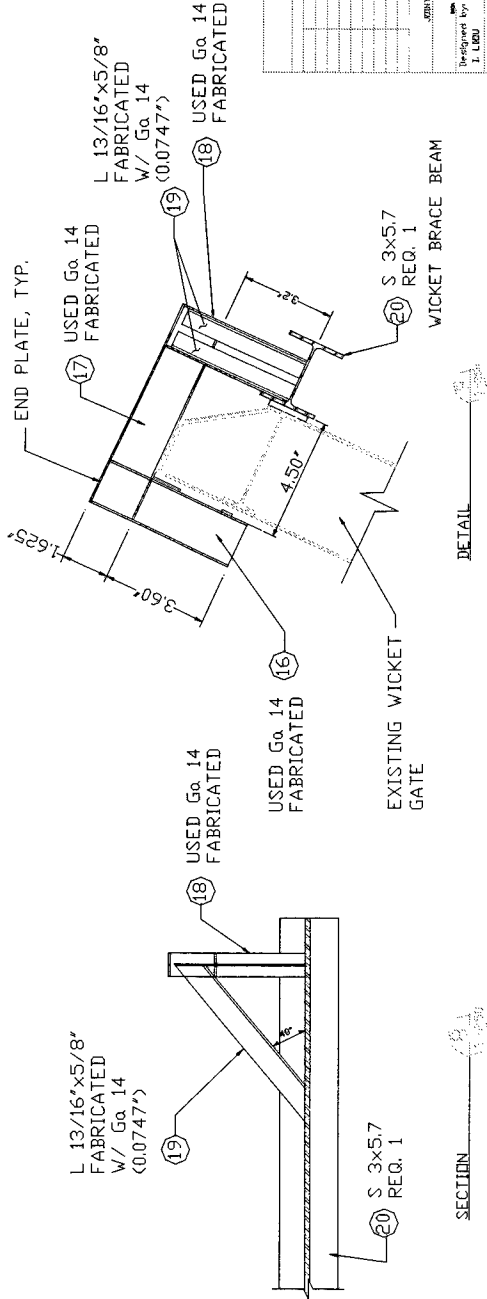

SECTION

US ARMY ENGINEER DISTRICT CORPS OF ENGINEERS LOUISVILLE, KENTUCKY	PROJECT NO. 13-100	DATE JULY 1999	SHEET NO. S-251
DESIGNED BY KEN V.	CHECKED BY M. DOWDRIE	SCALE 1" = 5'	TITLE BLANK & BEAM DETAILS
APPROVED BY [Signature]	DATE [Date]	PROJECT NO. 13-100	SHEET NO. S-251
PROJECT NAME WICKET GATE			
PROJECT LOCATION [Location]			
PROJECT DESCRIPTION [Description]			

REPORT DOCUMENTATION PAGE

Form Approved
OMB No. 0704-0188

Public reporting burden for this collection of information is estimated to average 1 hour per response, including the time for reviewing instructions, searching existing data sources, gathering and maintaining the data needed, and completing and reviewing the collection of information. Send comments regarding this burden estimate or any other aspect of this collection of information, including suggestions for reducing this burden, to Washington Headquarters Services, Directorate for Information Operations and Reports, 1215 Jefferson Davis Highway, Suite 1204, Arlington, VA 22202-4302, and to the Office of Management and Budget, Paperwork Reduction Project (0704-0188), Washington, DC 20503.

1. AGENCY USE ONLY (Leave blank)		2. REPORT DATE September 2000	3. REPORT TYPE AND DATES COVERED Final report	
4. TITLE AND SUBTITLE Olmsted Wicket Blank Experiment in 1:5-Scale Hydraulic Flume Model			5. FUNDING NUMBERS	
6. AUTHOR(S) Mostafiz R. Chowdhury, W. Glenn Davis				
7. PERFORMING ORGANIZATION NAME(S) AND ADDRESS(ES) U.S. Army Engineer Research and Development Center Structures and Coastal and Hydraulics Laboratories 3909 Halls Ferry Road, Vicksburg, MS 39180-6199			8. PERFORMING ORGANIZATION REPORT NUMBER ERDC TR-00-7	
9. SPONSORING/MONITORING AGENCY NAME(S) AND ADDRESS(ES) U.S. Army Corps of Engineers, Washington, DC 20314-1000 U.S. Army Engineer District, Louisville, Louisville, KY 40201-0059			10. SPONSORING/MONITORING AGENCY REPORT NUMBER	
11. SUPPLEMENTARY NOTES				
12a. DISTRIBUTION/AVAILABILITY STATEMENT Approved for public release; distribution is unlimited			12b. DISTRIBUTION CODE	
13. ABSTRACT (Maximum 200 words) <p>The experimental results for wicket blank tested in the 1:5-scale hydraulic flume model are presented in this document. The results of this model investigation provide guidance to design necessary equipment and appurtenances for wicket blank operations in the field. The wicket blank will be used during the maintenance operation to facilitate the removal of any jammed wicket gate for various blank operations. No significant operational problems were discovered during this investigation. The wicket blank and the proposed installation and removal procedures proved to be adequate.</p>				
14. SUBJECT TERMS Hydraulic model Olmsted wicket blank Olmsted Locks & Dam Scaled physical model			15. NUMBER OF PAGES 73	
			16. PRICE CODE	
17. SECURITY CLASSIFICATION OF REPORT UNCLASSIFIED	18. SECURITY CLASSIFICATION OF THIS PAGE UNCLASSIFIED	19. SECURITY CLASSIFICATION OF ABSTRACT	20. LIMITATION OF ABSTRACT	