

# LOAN DOCUMENT

PHOTOGRAPH THIS SHEET

①

DTIC ACCESSION NUMBER

LEVEL

INVENTORY

Bioventing Pilot Test Work Plan for...  
DOCUMENT IDENTIFICATION  
Jul 94

**DISTRIBUTION STATEMENT A**  
Approved for Public Release  
Distribution Unlimited

DISTRIBUTION STATEMENT

DATE ACCESSIONED

DATE RETURNED

REGISTERED OR CERTIFIED NUMBER

NTIS		GRAM	<input checked="" type="checkbox"/>
DTIC		TRAC	<input type="checkbox"/>
UNANNOUNCED			<input type="checkbox"/>
JUSTIFICATION			
BY			
DISTRIBUTION/			
AVAILABILITY CODES			
DISTRIBUTION	AVAILABILITY AND/OR SPECIAL		
A-1			

DISTRIBUTION STAMP

20001129 071

DATE RECEIVED IN DTIC

REGISTERED OR CERTIFIED NUMBER

PHOTOGRAPH THIS SHEET AND RETURN TO DTIC-FDAC

H  
A  
N  
D  
L  
E  
  
W  
I  
T  
H  
  
C  
A  
R  
E

19-20-14 File

# DRAFT

**Bioventing Pilot Test Work Plan for  
Site 6B - Fuel Farm (Tank 191)  
US Coast Guard Support Center Kodiak  
Kodiak, Alaska**

Prepared For

**Air Force Center for Environmental Excellence  
Brooks AFB, Texas**

and

**US Coast Guard Support Center Kodiak  
Kodiak, Alaska**

**ES**  
Engineering-Science, Inc.

1700 BROADWAY, SUITE 900  
DENVER, COLORADO 80290

July 1994

ES ENGINEERING-SCIENCE

AQ M01-02-0375

### DEFENSE TECHNICAL INFORMATION CENTER REQUEST FOR SCIENTIFIC AND TECHNICAL REPORTS

Title AFCEE Collection

**1. Report Availability** (Please check one box)

- This report is available. Complete sections 2a - 2f.
- This report is not available. Complete section 3.

**2a. Number of Copies Forwarded**

1 each

**2b. Forwarding Date**

July/2000

**2c. Distribution Statement** (Please check ONE box)

DoD Directive 5230.24, "Distribution Statements on Technical Documents," 18 Mar 87, contains seven distribution statements, as described briefly below. Technical documents MUST be assigned a distribution statement.

- DISTRIBUTION STATEMENT A: Approved for public release. Distribution is unlimited.
- DISTRIBUTION STATEMENT B: Distribution authorized to U.S. Government Agencies only.
- DISTRIBUTION STATEMENT C: Distribution authorized to U.S. Government Agencies and their contractors.
- DISTRIBUTION STATEMENT D: Distribution authorized to U.S. Department of Defense (DoD) and U.S. DoD contractors only.
- DISTRIBUTION STATEMENT E: Distribution authorized to U.S. Department of Defense (DoD) components only.
- DISTRIBUTION STATEMENT F: Further dissemination only as directed by the controlling DoD office indicated below or by higher authority.
- DISTRIBUTION STATEMENT X: Distribution authorized to U.S. Government agencies and private individuals or enterprises eligible to obtain export-controlled technical data in accordance with DoD Directive 5230.25, Withholding of Unclassified Technical Data from Public Disclosure, 6 Nov 84.

**2d. Reason For the Above Distribution Statement** (in accordance with DoD Directive 5230.24)

**2e. Controlling Office**

HQ AFCEE

**2f. Date of Distribution Statement Determination**

15 Nov 2000

**3. This report is NOT forwarded for the following reasons.** (Please check appropriate box)

- It was previously forwarded to DTIC on ..... (date) and the AD number is .....
- It will be published at a later date. Enter approximate date if known. ....
- In accordance with the provisions of DoD Directive 3200.12, the requested document is not supplied because: .....

**Print or Type Name**

Laura Peña

**Signature**

Laura Peña

**Telephone**

210-536-1431

(For DTIC Use Only)

**AQ Number** MD-02-0325

**DRAFT**

**BIOVENTING PILOT TEST WORK PLAN FOR  
SITE 6B - FUEL FARM (TANK 191)  
US COAST GUARD SUPPORT CENTER  
KODIAK, ALASKA**

**JULY 1994**

**Prepared for:**

**Air Force Center for Environmental Excellence  
Brooks AFB, Texas**

**and**

**US Coast Guard Support Center Kodiak  
Kodiak, Alaska**

**Prepared by:**

**Engineering-Science, Inc.  
1700 Broadway, Suite 900  
Denver, Colorado 80290**

# TABLE OF CONTENTS

## BIOVENTING PILOT TEST WORK PLAN FOR SITE 6B - FUEL FARM (TANK 191) US COAST GUARD SUPPORT CENTER KODIAK, ALASKA

	<u>Page</u>
1.0 INTRODUCTION .....	1
2.0 SITE DESCRIPTION .....	2
2.1 Site Location and History .....	2
2.2 Site Geology .....	2
2.3 Site Contaminants.....	2
3.0 SITE-SPECIFIC ACTIVITIES.....	7
3.1 Site Layout .....	7
3.2 Vent Well .....	9
3.3 Monitoring Points.....	9
3.4 Handling of Drill Cuttings.....	9
3.5 Soil and Soil Gas Sampling.....	13
3.5.1 Soil Samples .....	13
3.5.2 Soil Gas Samples.....	13
3.6 Blower System .....	14
3.7 In Situ Respiration Test.....	14
3.8 Air Permeability Test .....	14
3.9 Installation of Extended (1-Year) Pilot Test Bioventing System.....	17
4.0 EXCEPTIONS TO PROTOCOL PROCEDURES.....	17
5.0 COAST GUARD SUPPORT REQUIREMENTS.....	17
5.1 Test Preparation.....	17
6.0 PROJECT SCHEDULE.....	18
7.0 POINTS OF CONTACT.....	19
8.0 REFERENCES .....	19

## FIGURES

	<u>Page</u>
2.1 Site Location 6B-Fuel Farm.....	3
2.2 Tank Group 3 Layout .....	4
2.3 Tank 191 Site Layout .....	5
3.1 Proposed Vent Well, Monitoring Point, and Blower Locations Tank 191 .....	7
3.2 Proposed Injection Vent Well Construction Detail.....	9
3.3 Proposed Monitoring Point Construction Detail .....	10
3.4 Proposed Blower System Instrumentation Diagram for Air Injection .....	13

**DRAFT**

**BIOVENTING PILOT TEST WORK PLAN FOR  
SITE 6B - FUEL FARM (TANK 191)  
US COAST GUARD SUPPORT CENTER**

**KODIAK, ALASKA**

**1.0 INTRODUCTION**

This work plan presents the scope of an *in situ* bioventing pilot test for treatment of fuel-contaminated soils associated with Tank 191 at the Nyman Peninsula Fuel Farm (Site 6B) at the US Coast Guard Support Center in Kodiak, Alaska. The pilot test has three primary objectives: 1) to assess the potential for supplying oxygen throughout the contaminated soil interval, 2) to determine the rate at which indigenous microorganisms will degrade fuel when stimulated by oxygen-rich soil gas, and 3) to evaluate the potential for sustaining these rates of biodegradation until fuel contamination is remediated to concentrations below regulatory standards.

The pilot test will be conducted in two phases. A vent well (VW) and monitoring points (MPs) will be installed near the location of Tank 191 during site investigation activities. The initial stage will also include an *in situ* respiration test and an air permeability test. This initial testing is expected to take approximately 2 weeks. During the second phase, a bioventing system will be installed and monitored over a 1-year period.

If bioventing proves to be feasible at this site, pilot test data could be used to design a full-scale remediation system and to estimate the time required for site cleanup. An added benefit of the pilot testing at Site 6B (Tank 191) is that a significant amount of the fuel contamination should be biodegraded during the 1-year pilot test, as the testing will take place within the most contaminated soils identified to date at the site.

Additional background information on the development and recent success of the bioventing technology is presented in the *Test Plan and Technical Protocol For A Field Treatability Test For Bioventing* (Hinchee et al., 1992). This protocol document will also serve as the primary reference for pilot test VW and MP designs and detailed procedures which will be used during the test.

## **2.0 SITE DESCRIPTION**

### **2.1 Site Location and History**

Site 6B is located on the central Nyman Peninsula, as shown in Figure 2.1, and contains 13 large above- and underground fuel storage tanks that were constructed between 1942 and 1990, including 3 that are currently used for the storage of JP-5. Tank Group 3 (Figure 2.2) includes inactive Tanks 191, 192, and 193, as well as active JP-5 Tanks N-10, N-12, and N-60. The primary uses of these tanks have been diesel and JP-5 storage; however, Tank 192 currently contains waste oil. Tank 191, located in Tank Group 3 at the southern and topographically lowest end of the Nyman Peninsula Fuel Farm (Figure 2.3), is an inactive 567,000-gallon concrete and steel underground storage tank (UST) formerly containing diesel oil and JP-5 fuel.

Tank Group 3 tanks have documented histories of leakage. The largest spill, resulting from an inadvertent overflow of Tank 192, occurred in 1970. Surface drainage from this spill reportedly migrated past Building N-13 to Outer Women's Bay (Figure 2.2). Tank 191 was known to leak as early as 1954. While one report indicates the rate of leakage to be 500 gallons per day in 1954, another report indicates the tank was secured in the mid 1950's because it leaked approximately 2,300 gallons per day. Due to its poor condition, Tank 191 was abandoned in 1978. Additionally, records indicate that Tank 192 was leaking at a rate of 1,200 gallons per day in 1963, however, the tank was never secured [Science Applications International Corporation (SAIC), 1994].

### **2.2 Site Geology**

Geologic units beneath Site 6B consist of glacial deposits overlying slate bedrock. The unconsolidated glacial deposits are predominantly silt and clay-rich glacial tills and some recessional outwash alluvial deposits. The glacial deposits are typically covered by post-glacial peats and organic soils that have been overlaid by multiple volcanic ash layers. The top of the slate bedrock was encountered at approximately 18 feet below ground surface (bgs) at boring SB-6B-141 (now monitoring well MW-6B-141). The slate bedrock consists of a number of irregular flows with varying physical characteristics (SAIC, 1994). Ground water beneath the Tank 191 site occurs at a depth of approximately 15 feet bgs and flows to the northwest at a gradient of approximately 0.14 foot/foot.

### **2.3 Site Contaminants**

The primary contaminants at this site are petroleum hydrocarbons associated with diesel fuel and JP-5 jet fuel, which have been detected in the soils at depths ranging from the surface to a depth of 19.5 feet bgs (SB-6B-141). Total recoverable petroleum hydrocarbons (TRPH) were detected at a maximum concentration of 3,400 milligrams per kilogram (mg/kg) in sample SB-6B-141-02-1 at a depth of 18 to 19 feet bgs. Samples collected from a depth beginning at 3 feet bgs from SB-6B-140 and SB-6B-150 exhibited lower TRPH concentrations of 2,400 mg/kg and 2,500 mg/kg, respectively. Maximum

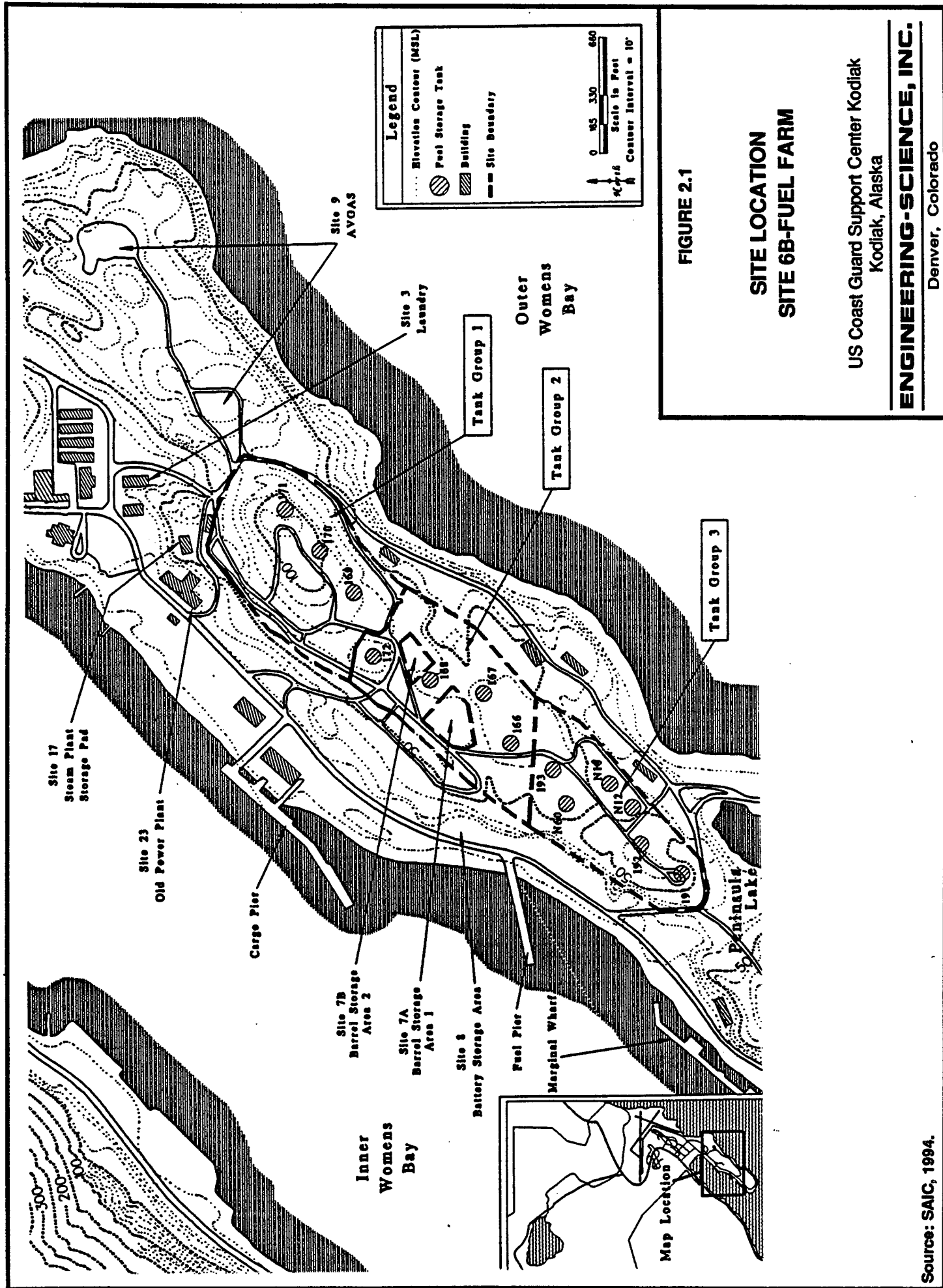

Source: SAIC, 1994.

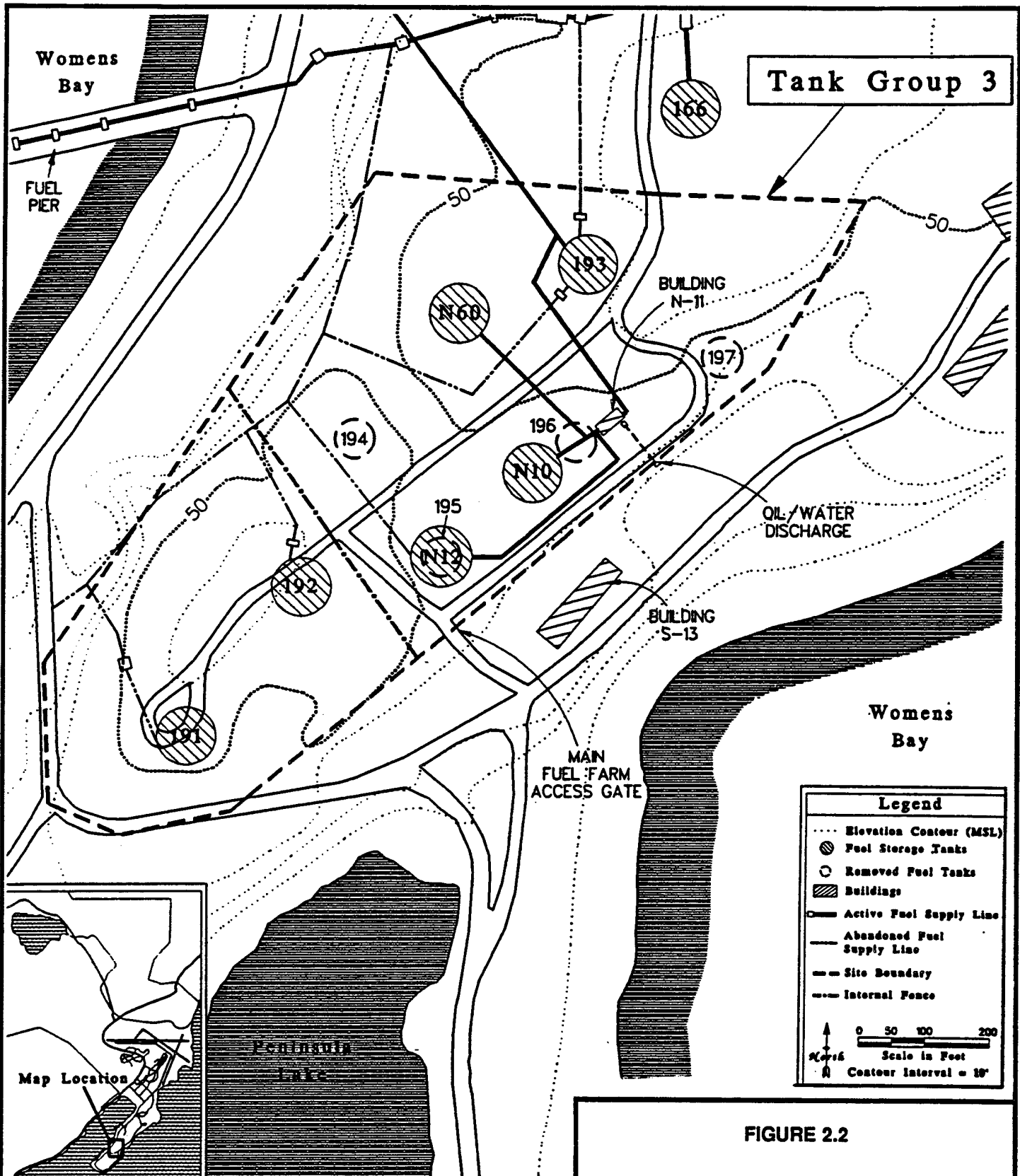

FIGURE 2.2

**TANK GROUP 3 LAYOUT**

US Coast Guard Support Center Kodiak  
Kodiak, Alaska

**ENGINEERING-SCIENCE, INC.**

Denver, Colorado

Source: SAIC, 1994.

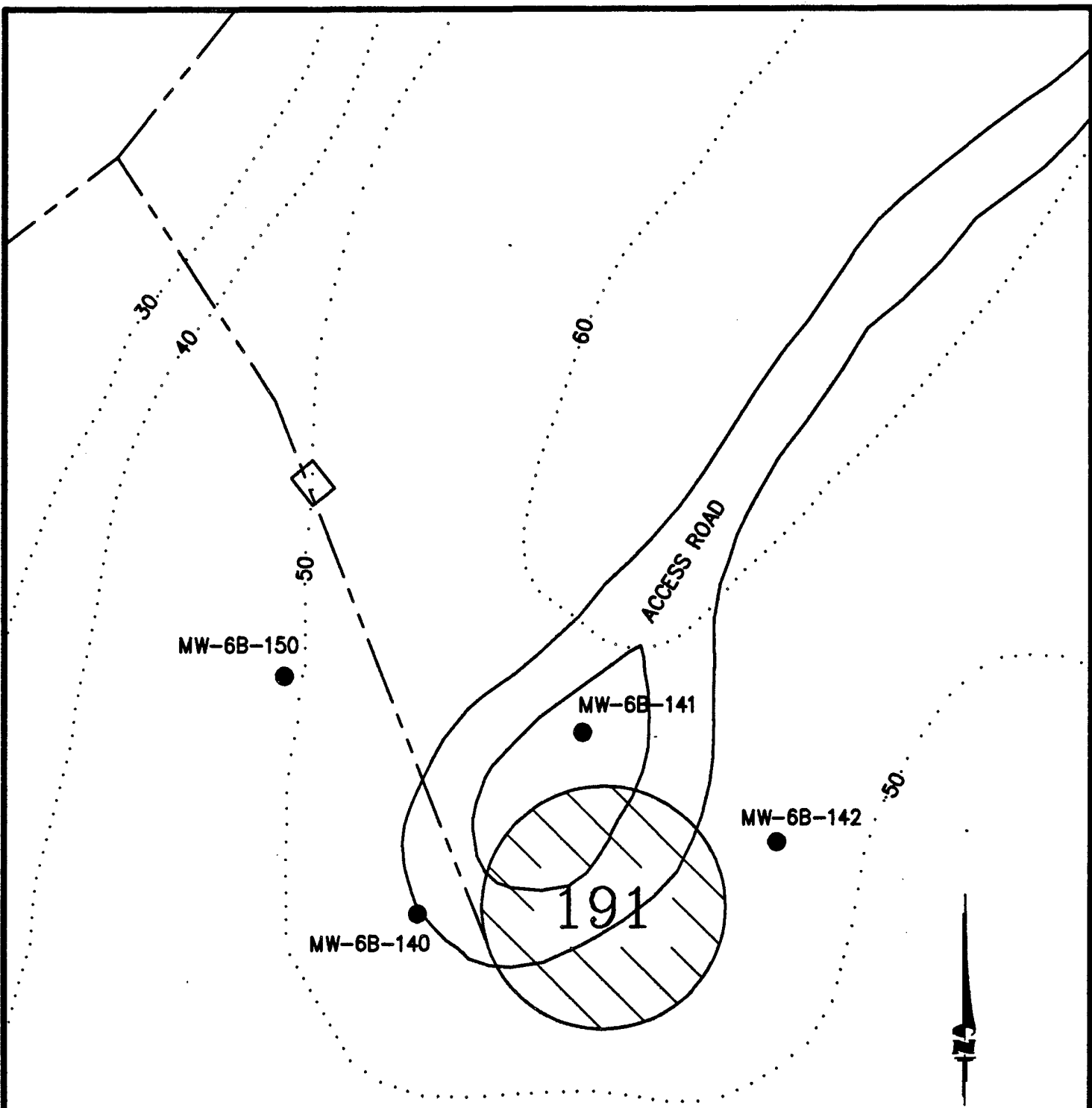

NOT TO SCALE

**LEGEND**

- MW-6B-140 GROUND WATER MONITORING WELL
- ABANDONED FUEL LINE
- ..... TOPOGRAPHIC CONTOUR INTERVAL (FEET ABOVE MSL)

**FIGURE 2.3**

**TANK 191  
SITE LAYOUT**

US Coast Guard Support  
Center Kodiak  
Kodiak, Alaska

---

**ENGINEERING-SCIENCE, INC.**

Denver, Colorado

concentrations of ethylbenzene and xylenes were detected at 3 to 5 feet bgs in SB-6B-140 (now monitoring well 6B-140) at concentrations of 1,900 and 6,200 micrograms per kilogram ( $\mu\text{g}/\text{kg}$ ), respectively. Benzene and toluene were not detected above background concentrations in any soil samples from the Tank 191/192 area (SAIC, 1994).

### 3.0 SITE-SPECIFIC ACTIVITIES

The purpose of this section is to describe the work that will be performed by Engineering-Science, Inc. (ES) at Site 6B, Tank 191. Activities that will be performed include siting and construction of a central air injection VW, and two vapor MPs; an *in situ* respiration test; an air permeability test; and the installation of a long-term bioventing pilot test system. Soil and soil gas sampling procedures and the blower configuration that will be used to inject air (oxygen) into contaminated soils through the VW are also discussed in this section. No dewatering will take place during the pilot test. Pilot test activities will be confined to unsaturated soils remediation. Existing monitoring wells will not be used as primary air injection wells. However, monitoring wells which have a portion of their screened interval above the water table may be used as vapor MPs or to measure the composition of background soil gas.

#### 3.1 Site Layout

A general description of criteria for siting a central VW and vapor MPs are included in the protocol document (Hinchee et al., 1992). Figure 3.1 illustrates the proposed locations of the central VW and MPs at this site. The final locations of these wells may vary slightly from the proposed locations if significant fuel contamination is not observed in the boring for the VW. Based on site investigation data, the central VW should be located near soil boring SB-6B-141. Soils in this area are expected to be oxygen depleted (<2%) due to high hydrocarbon levels, and increased biological activity should be stimulated by oxygen-rich soil gas ventilation during pilot test operations.

Based on the depth of contamination at this site and the experience that ES has had with similar soil types, the potential radius of venting influence around the central air injection well is expected to be 30 to 40 feet. Two vapor MPs (MPA and MPB) will be located within a 35-foot radial distance of the central VW. Monitoring well MW-6B-141 will also be used as a soil gas monitoring point. A third MP (exact location to be determined in the field) will be located within approximately 1,000 feet of the site in an uncontaminated area, and will be used to measure background levels of oxygen and carbon dioxide and to determine if natural carbon sources are contributing to oxygen uptake during the *in situ* respiration test. An existing ground water monitoring well with a portion of the screen extending above the ground water table may be used as a background MP.

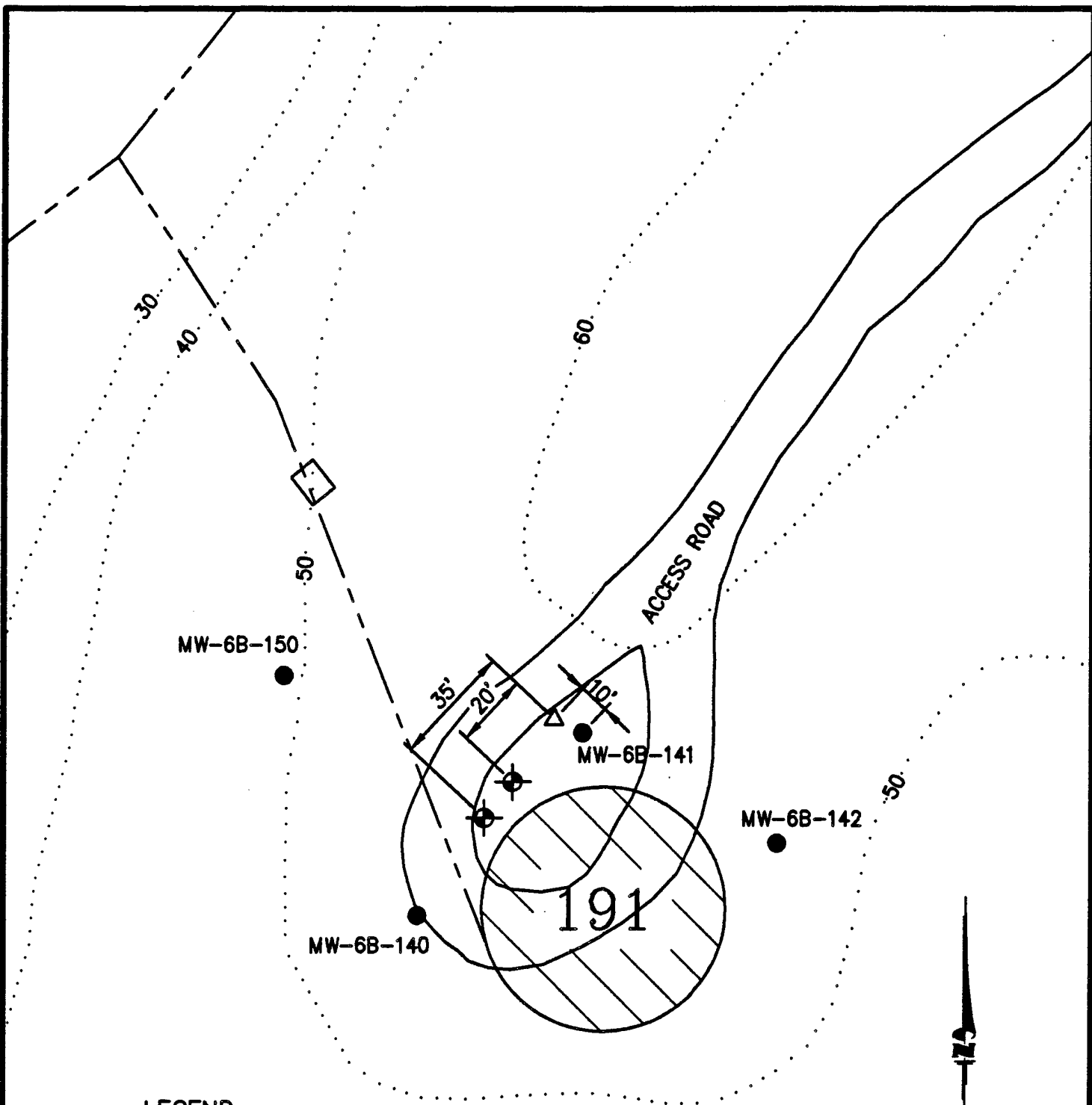

**LEGEND**

- MW-6B-140 GROUND WATER MONITORING WELL
- ABANDONED FUEL LINE
- ..... TOPOGRAPHIC CONTOUR INTERVAL (FEET ABOVE MSL)
- △ PROPOSED VENT WELL LOCATION
- ⊕ PROPOSED MONITORING POINT LOCATION

NOTE: PROPOSED BLOWER LOCATION IS DIRECTLY OVER VENT WELL.

NOT TO SCALE

**FIGURE 3.1**

**PROPOSED VENT WELL,  
MONITORING POINT, AND  
BLOWER LOCATIONS  
TANK 191**

US Coast Guard Support  
Center Kodiak  
Kodiak, Alaska

---

**ENGINEERING-SCIENCE, INC.**

Denver, Colorado

### **3.2 Vent Well**

The VW will be constructed of 4-inch inside-diameter (ID) Schedule 40 PVC, with a 15-foot interval of 0.04-inch slotted screen set at approximately 5 to 20 feet bgs. Flush-threaded PVC casing and screen with no organic solvents or glues will be used. The filter pack will be clean, well-rounded silica sand with an 6-9 grain size, and will be placed in the annular space of the screened interval. A 2-foot layer of granular bentonite, hydrated in place with potable water, will be placed directly over the filter pack to produce an air-tight seal above the screened interval. A complete seal is critical to prevent injected air from short circuiting to the surface during the bioventing test. The remaining annular space will then be filled to the ground surface with bentonite/cement grout. Figure 3.2 illustrates the proposed VW construction for this site.

### **3.3 Monitoring Points**

A typical multi-depth vapor MP installation for this site is shown in Figure 3.3. Soil gas oxygen and carbon dioxide concentrations will be monitored at depths of approximately 5, 10, and 15 feet bgs at each location. MPA and MPB will be located 20 and 35 feet from the VW, respectively. Additionally, MW-6B-141 will be 10 feet from the VW and will be used as an MP. Actual monitoring point depths and locations will be determined in the field. Soil temperature will be monitored using thermocouples installed at the shallow and deep intervals at MPA. Multi-depth monitoring will confirm that the entire soil profile is receiving oxygen and be used to measure fuel biodegradation rates at each depth.

The MPs will be constructed with three vapor probes. Each vapor probe, constructed of a 6-inch-long section of 1-inch-diameter PVC well screen, will be placed within a 2-foot layer of 6-9 sieve-size silica sand. The annular spaces between the three screened MP intervals will be sealed with bentonite to isolate the intervals. The bentonite seals will consist of granular bentonite or bentonite pellets hydrated in place. The bentonite within 2 feet above and below the sand intervals will be placed in approximately 6-inch layers and hydrated with potable water prior to placement of subsequent layers to assure complete saturation and hydration of the bentonite. Additional details on VW and MP construction are found in Section 4 of the protocol document (Hinchee et al., 1992).

### **3.4 Handling of Drill Cuttings**

Drill cuttings will be placed on plastic sheeting and segregated at 5-foot intervals. Headspace readings will be used to determine the disposition of cuttings. Headspace readings will be performed as specified in the Alaska Department of Environmental Conservation (ADEC) Standard Quality Assurance Program Plan for Underground Storage Tank Systems Regulated by 18 AAC78 (Standard QAPP). Cuttings with representative soil sample headspace readings less than 20 parts per million volume per volume (ppmv) will be spread on the ground surface at the site. Twenty ppmv was chosen

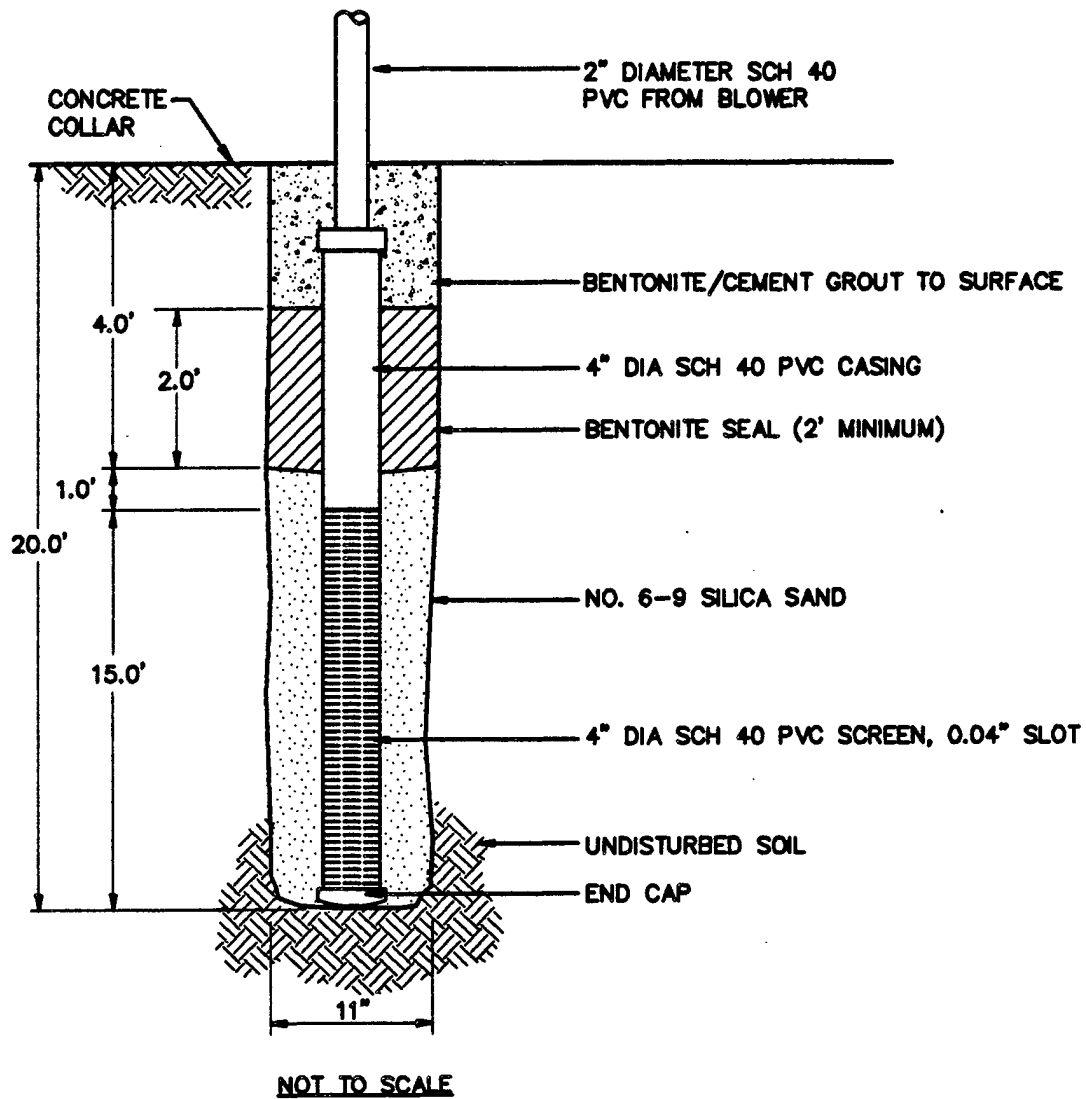
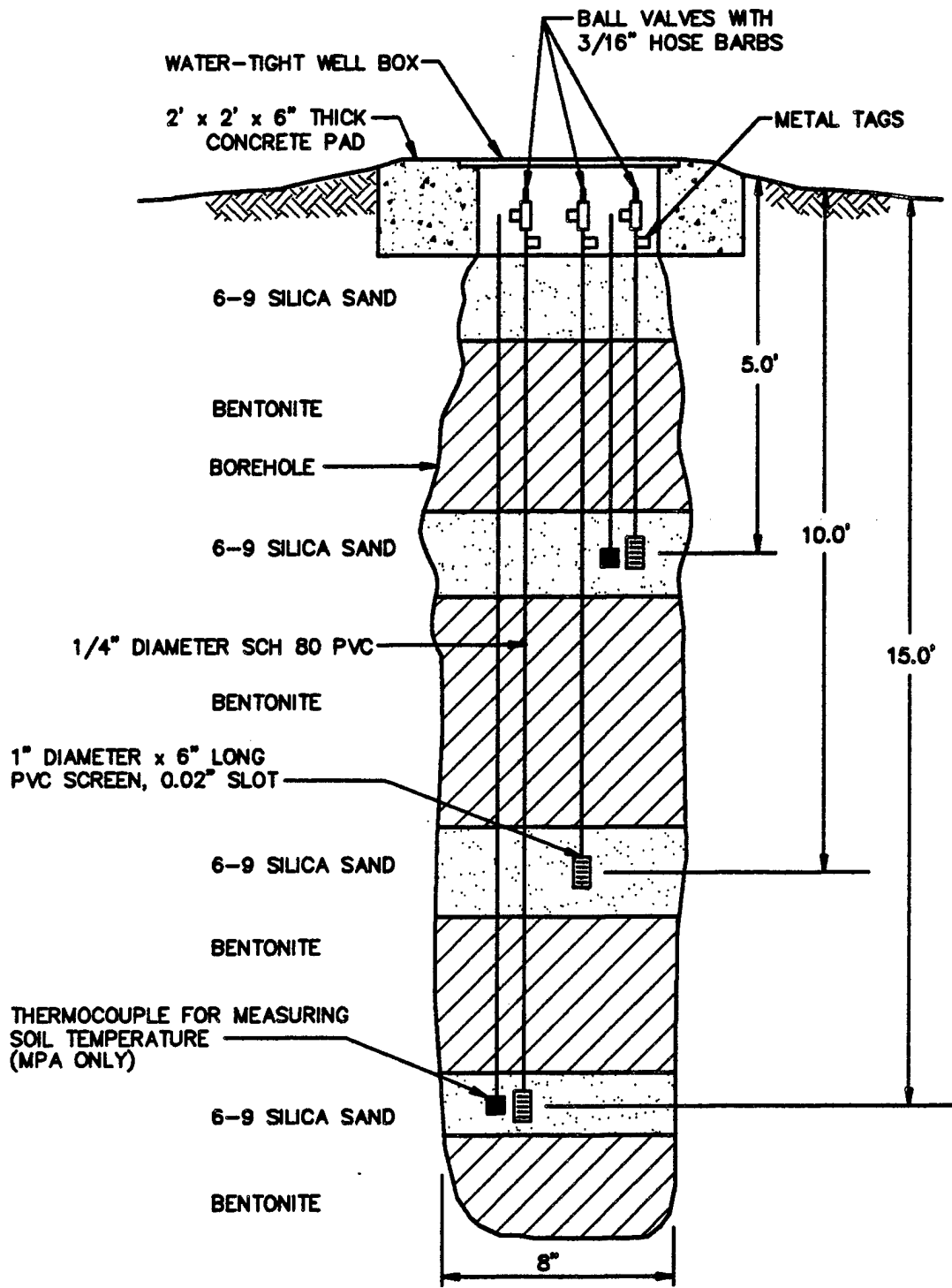

**FIGURE 3.2**  
**PROPOSED**  
**INJECTION VENT WELL**  
**CONSTRUCTION DETAIL**  
**SITE 6B, TANK 191**

US Coast Guard Support  
Center Kodiak  
Kodiak, Alaska

---

**ENGINEERING-SCIENCE, INC.**  
Denver, Colorado



NOT TO SCALE

**FIGURE 3.3**

**PROPOSED  
MONITORING POINT  
CONSTRUCTION DETAIL  
SITE 6B, TANK 191**

US Coast Guard Support  
Center Kodiak  
Kodiak, Alaska

**ENGINEERING-SCIENCE, INC.**

Denver, Colorado

as the criteria because elevated headspace moisture conditions may cause erratic meter responses as noted in the Standard QAPP.

Cuttings with headspace readings greater than 20 ppmv will be placed in 55-gallon U.S. Department of Transportation approved drums. Drums will be properly labeled and transported to a drum storage area designated by the U.S. Coast Guard. Containerized drill cuttings will become the responsibility of the Coast Guard, or their designated contractor, and will be analyzed and disposed of in accordance with the current procedures for ongoing remedial investigations. A maximum of 10 55-gallon drums of cuttings will be generated.

### **3.5 Soil and Soil Gas Sampling**

#### **3.5.1 Soil Samples**

Three soil samples will be collected from the pilot test area during the installation of the VW and MPs. Sampling procedures will follow those outlined in the protocol document and the Standard QAPP which was adopted by ES in June 1993. These procedures were approved by ADEC for the soil sampling activities performed by ES at the pilot test sites at Elmendorf Air Force Base in June 1993. A total hydrocarbon vapor analyzer will be used during drilling to screen split-spoon samples for intervals of high fuel contamination. Based on field screening results, one soil sample will be collected from the most contaminated interval of the VW boring, and one sample will be collected from the interval of highest apparent contamination in each of the borings for the two MPs closest to the VW. Soil samples will be analyzed for diesel-range organics (DRO) by Method SW8015M; gasoline-range organics (GRO) by Method SW8015M; benzene, toluene, ethylbenzene, and xylenes (BTEX) by Method SW8020; and a single sample will be analyzed for soil moisture, pH, particle sizing, alkalinity, total iron, and nutrients.

Samples for DRO, GRO, and BTEX analysis will be collected using a split-spoon sampler containing brass tube liners. Soil samples collected in the brass tubes for DRO, GRO, BTEX, and physical parameter analyses will be immediately trimmed, and the ends will be sealed with aluminum foil or Teflon<sup>®</sup> fabric held in place by plastic caps. Soil samples will be labeled following the nomenclature specified in the protocol document (Section 5), wrapped in plastic, placed in a cooler, and maintained at a temperature of 4 degrees centigrade for shipment. A chain-of-custody form will be filled out, and the cooler will be shipped to the PACE, Inc. laboratory in Huntington Beach, California for analysis. This laboratory has been audited by the Air Force and meets all quality assurance/quality control (QA/QC) and certification requirements for the State of Alaska.

#### **3.5.2 Soil Gas Samples**

Initial soil gas samples will be collected in SUMMA<sup>®</sup> canisters, in accordance with the Bioventing Field Sampling Plan (ES, 1992), from the VW and from the MPs closest to and furthest from the VW. Additionally, these soil gas samples will be used to predict

potential air emissions, to determine the reduction in BTEX and total volatile hydrocarbons (TVH) during the 1-year test, and to detect any migration of these vapors from the source area.

Soil gas sample canisters will be placed in a small cooler and packed with foam pellets to prevent excessive movement during shipment. Samples will not be sent on ice to prevent condensation of hydrocarbons. A chain-of-custody form will be filled out, and the cooler will be shipped to the Air Toxics, Inc. laboratory in Folsom, California for analysis.

### **3.6 Blower System**

A 2.5-horsepower regenerative blower capable of injecting air at a rate of 100 standard cubic feet per minute (scfm) at a pressure of 50 inches of water will be used to conduct the initial air permeability test and the extended pilot test. Figure 3.4 is a schematic of a typical air injection system used for pilot testing. The maximum power requirement anticipated for this pilot test is 230/208-volt, single-phase, 30-amp service. Additional details on power supply requirements are described in Section 5.0, Coast Guard Support Requirements.

### **3.7 *In Situ* Respiration Test**

The objective of the *in situ* respiration test is to determine the rate at which soil bacteria degrade petroleum hydrocarbons. Respiration tests will be performed at selected MPs where bacterial biodegradation of hydrocarbons is indicated by low oxygen levels and elevated carbon dioxide concentrations in the soil gas. Using 1-cubic-foot-per-minute (cfm) pumps, air will be injected into approximately four MP depth intervals containing low levels (<2%) of oxygen. A 20-hour air injection period will be used to oxygenate local contaminated soils. At the end of the 20-hour air injection period, the air supply will be cut off, and oxygen, carbon dioxide, and TVH concentrations will be monitored for the following 48 to 72 hours. The decline in oxygen and increase in carbon dioxide concentrations over time will be used to estimate rates of bacterial degradation of fuel residuals. Helium will also be injected into the selected MP screened intervals to assess the effectiveness of the bentonite seals. Additional details on the *in situ* respiration test are found in Section 5.7 of the protocol document (Hinchee et al., 1992).

### **3.8 Air Permeability Test**

The objective of the air permeability test is to determine the extent of the subsurface that can be oxygenated using one air injection VW. Prior to initiating the test, baseline concentrations of oxygen, carbon dioxide, moisture, and TVH will be measured in soil gas from the VW and each MP screened interval.

Air will be injected into the 4-inch-diameter VW using the blower unit, and pressure response will be measured at each MP with differential pressure gauges to determine the region influenced by the unit. Oxygen will also be monitored in the MPs to ascertain

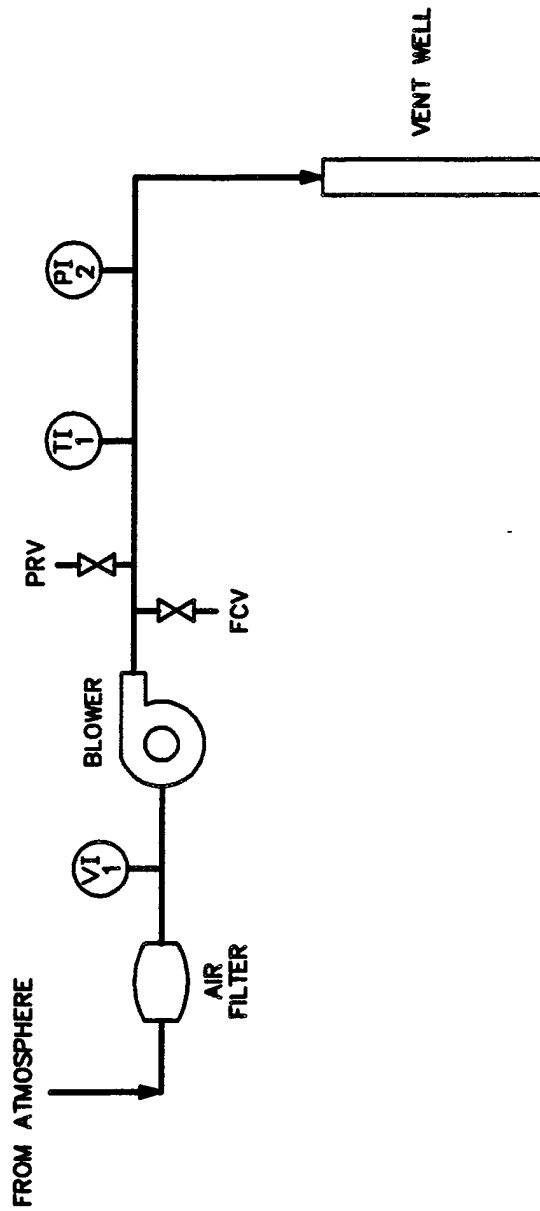

**LEGEND**

- ⊙ VI 1 VACUUM INDICATOR
- ⊙ PI 2 PRESSURE INDICATOR
- ⊙ TI 1 TEMPERATURE INDICATOR
- FCV FLOW CONTROL VALVE
- PRV PRESSURE RELIEF VALVE

**FIGURE 3.4**

**PROPOSED BLOWER SYSTEM  
INSTRUMENTATION DIAGRAM  
FOR AIR INJECTION**

US Coast Guard Support  
Center Kodiak  
Kodiak, Alaska

**ENGINEERING-SCIENCE, INC.**  
Denver, Colorado

whether oxygen levels in the soil increase as the result of air injection. One air permeability test lasting 4 to 24 hours will be performed.

### **3.9 Installation of Extended (1-Year) Pilot Test Bioventing System**

An extended, 1-year bioventing system also will be installed at Tank 191. It is anticipated that the extended-test will require a 2.5 horsepower blower to inject air into the subsurface at flow rates in the range of 10 to 30 scfm. A Coast Guard electrician will be requested to wire the blower to line power. The blower will be housed in a small, prefabricated shed to provide protection from the weather. The blower unit will be explosion-proof, and electrical wiring will be installed in accordance with the national electric code (NEC) and Coast Guard codes for the selected location.

The system will be in operation for 1 year, and every 6 months ES personnel will conduct *in situ* respiration tests to monitor the long-term performance of this bioventing system. Weekly system checks (generally less than 10 minutes on site) will be performed by Coast Guard personnel. If required, major maintenance of the blower unit will be performed by ES-Denver personnel. Detailed blower system information and a maintenance schedule will be included in the operation and maintenance manual provided to the Coast Guard. More detailed information regarding the test procedures are provided in the protocol document (Hinchee et al., 1992).

### **4.0 EXCEPTIONS TO PROTOCOL PROCEDURES**

The procedures that will be used to measure the air permeability of the soil and *in situ* respiration rates are described in Sections 4 and 5, respectively, of the protocol document (Hinchee et al., 1992). No exceptions to the protocol are anticipated at Site 6B.

### **5.0 COAST GUARD SUPPORT REQUIREMENTS**

#### **5.1 Test Preparation**

The following Coast Guard support is needed prior to the arrival of the drilling subcontractor and the ES pilot test team:

- Assistance in obtaining drilling and digging permits.
- Confirmation of available power source, including 230-volt, 30-amp, single-phase service and a breaker box with one 230-volt receptacle and two 110-volt receptacles located near Tank 191. Electrical wiring will conform to the NEC and Coast Guard electrical codes.
- Provision of any paperwork required to obtain gate passes and security badges for approximately two ES employees, two drillers, and an electrician (if a Coast Guard electrician is not available). Vehicle passes will be needed for two ES rental trucks, and a drill rig and supply truck.

During the initial testing, the following Coast Guard support is needed:

- Twelve square feet of desk space and a telephone in a building located as close to the site as practical.
- The use of a facsimile machine for transmitting 15 to 20 pages of test results.
- A decontamination area where the driller can clean augers between borings.
- Acceptance of responsibility for drill cuttings from VW and MP borings, including any drum sampling to determine hazardous waste status.

During the 1-year extended pilot test, Coast Guard personnel will be required to perform the following activities:

- Check the blower system once per week to ensure that it is operating and to record the air injection pressure. ES will provide a brief training session on this procedure.
- If the blower stops working, notify Mr. Brian Blicher or Mr. Doug Downey (303) 831-8100 of ES; or Lt Col Ross Miller (AFCEE) at (210) 536-4331.
- Arrange site access for an ES technician to conduct an *in situ* respiration test approximately 6 months after the initial pilot test, and to conduct soil sampling and respiration testing approximately 1 year after the initial pilot test.

## 6.0 PROJECT SCHEDULE

The following schedule is contingent upon timely approval of this pilot test work plan and fulfillment of Coast Guard support requirements.

<u>Event</u>	<u>Date</u>
Initial Site Visit	18 July 1994
Draft Test Work Plan to AFCEE/Coast Guard	18 July 1994
Begin Initial Pilot Test	15 August 1994
Interim Results Report	23 September 1994
6-Month Respiration Test	February 1994
Final Respiration Test	August 1994

## 7.0 POINTS OF CONTACT

Coast Guard point of contact:

Lt. Woloszynski:  
CEU Juneau  
P.O. Box 21747  
Juneau, AK 99802  
(907) 463-2408  
Fax (907) 463-2404

Lt Col Ross Miller/Mr James Gonzales  
AFCEE/EST  
Brooks AFB, TX 78235-5000  
DSN 240-4366  
COM (210) 536-4366

Mr Doug Downey/Brian Blicker  
Engineering-Science, Inc.  
1700 Broadway, Suite 900  
Denver, CO 80290  
(303) 831-8100  
Fax (303) 831-8208

## 8.0 REFERENCES

Engineering-Science, Inc. 1992. *Field Sampling Plan for AFCEE Bioventing*. Denver, Colorado.

Hinchee, R.E., Ong, S.K., Miller, R.N., Downey, D.C., Frandt, R. 1992. *Test Plan and Technical Protocol for a Field Treatability Test for Bioventing*. January.

Science Applications International Corporation. 1994. *Draft RFI/CMS Report, Site 6B-Fuel Farm at U.S. Coast Guard Support Center Kodiak, Alaska*.