

LOAN DOCUMENT

PHOTOGRAPH THIS SHEET

①

DTIC ACCESSION NUMBER

LEVEL

INVENTORY

Bioventing Test Work Plan for Aboveground

DOCUMENT IDENTIFICATION

Oct 92

DISTRIBUTION STATEMENT A
Approved for Public Release
Distribution Unlimited

DISTRIBUTION STATEMENT

ACCESSION FOR	
NTIS	GRAM
DTIC	TRAC
UNANNOUNCED	
JUSTIFICATION	
BY	
DISTRIBUTION/	
AVAILABILITY CODES	
DISTRIBUTION	AVAILABILITY AND/OR SPECIAL
A-1	

DISTRIBUTION STAMP

DATE ACCESSIONED

DATE RETURNED

DTIC QUALITY INC. REGISTERED #
20001130 039

DATE RECEIVED IN DTIC

REGISTERED OR CERTIFIED NUMBER

PHOTOGRAPH THIS SHEET AND RETURN TO DTIC-FDAC

H
A
N
D
L
E

W
I
T
H

C
A
R
E

in file

DRAFT

**BIOVENTING TEST WORK PLAN FOR
ABOVEGROUND TREATMENT OF
HYDROCARBON CONTAMINATED SOILS AT
FIRE PROTECTION TRAINING AREA
WHITEMAN AFB, MISSOURI**

Prepared For

**Air Force Center for Environmental Excellence
Brooks AFB, Texas**

and

**351 CSG/CEV
Whiteman AFB, Missouri**

ES
Engineering-Science, Inc.

October 1992

1700 BROADWAY, SUITE 900
DENVER, COLORADO 80290

ES ENGINEERING-SCIENCE

AQM01-01-0363

DEFENSE TECHNICAL INFORMATION CENTER REQUEST FOR SCIENTIFIC AND TECHNICAL REPORTS

Title AFCEE Collection

1. Report Availability (Please check one box)

- This report is available. Complete sections 2a - 2f.
- This report is not available. Complete section 3.

2a. Number of Copies Forwarded

1 each

2b. Forwarding Date

July/2000

2c. Distribution Statement (Please check ONE box)

DoD Directive 5230.24, "Distribution Statements on Technical Documents," 18 Mar 87, contains seven distribution statements, as described briefly below. Technical documents MUST be assigned a distribution statement.

- DISTRIBUTION STATEMENT A: Approved for public release. Distribution is unlimited.
- DISTRIBUTION STATEMENT B: Distribution authorized to U.S. Government Agencies only.
- DISTRIBUTION STATEMENT C: Distribution authorized to U.S. Government Agencies and their contractors.
- DISTRIBUTION STATEMENT D: Distribution authorized to U.S. Department of Defense (DoD) and U.S. DoD contractors only.
- DISTRIBUTION STATEMENT E: Distribution authorized to U.S. Department of Defense (DoD) components only.
- DISTRIBUTION STATEMENT F: Further dissemination only as directed by the controlling DoD office indicated below or by higher authority.
- DISTRIBUTION STATEMENT X: Distribution authorized to U.S. Government agencies and private individuals or enterprises eligible to obtain export-controlled technical data in accordance with DoD Directive 5230.25, Withholding of Unclassified Technical Data from Public Disclosure, 6 Nov 84.

2d. Reason For the Above Distribution Statement (in accordance with DoD Directive 5230.24)

2e. Controlling Office

HQ AFCEE

2f. Date of Distribution Statement Determination

15 Nov 2000

3. This report is NOT forwarded for the following reasons. (Please check appropriate box)

- It was previously forwarded to DTIC on (date) and the AD number is
- It will be published at a later date. Enter approximate date if known.
- In accordance with the provisions of DoD Directive 3200.12, the requested document is not supplied because:

Print or Type Name

Laura Peña

Signature

Laura Peña

Telephone

210-536-1431

(For DTIC Use Only)

AQ Number M01-01-0363

**BIOVENTING TEST WORK PLAN FOR
ABOVEGROUND TREATMENT OF HYDROCARBON
CONTAMINATED SOILS
AT FIRE PROTECTION TRAINING AREA
WHITEMAN AFB, MISSOURI**

Prepared for:

**AIR FORCE CENTER FOR ENVIRONMENTAL EXCELLENCE
BROOKS AFB, TEXAS**

and

**351 CSG/CEV
WHITEMAN AIR FORCE BASE, MISSOURI**

October 1992

Prepared by:

**ENGINEERING-SCIENCE, INC.
1700 Broadway, Suite 900
Denver, Colorado 80290**

CONTENTS

	<u>Page</u>
1.0 Introduction.....	1
2.0 Site Description.....	1
2.1 Site Location and History.....	1
2.2 Site Geology.....	2
2.3 Site Contaminants.....	2
3.0 Site Specific Activities.....	4
3.1 Location and Construction of Vent Wells and Monitoring Points.....	4
3.2 Soil Gas Sampling.....	6
3.3 Blower System.....	6
3.4 Oxygen Distribution Test.....	6
3.5 Respiration Test.....	8
3.6 Installation of Long-Term System.....	8
4.0 Exceptions to Protocol Procedures.....	10
5.0 Base Support Requirements.....	10
5.1 Test Preparation.....	10
6.0 Project Schedule.....	11
7.0 Points of Contact.....	11

FIGURES

<u>No.</u>	<u>Title</u>	<u>Page</u>
2.1	Site Location.....	3
3.1	Bioventing Test Pile.....	5
3.2	Blower System Instrumentation Diagram for Air Injection.....	7
3.3	Bioventing Pile Sampling Locations.....	9

**BIOVENTING TEST WORK PLAN FOR
INSTALLATION RESTORATION PROGRAM SITE 2
FIRE PROTECTION TRAINING AREA
WHITEMAN AFB, MISSOURI**

1.0 INTRODUCTION

This test work plan presents the scope of an above-ground bioventing pilot test for treatment of fuel contaminated soils from Tank 141 at Whiteman Air Force Base. The above ground bioventing pilot test will be performed at Installation Restoration Program (IRP) Site 2, Fire Protection Training Area. The pilot test has three primary objectives: 1) to assess the potential for supplying oxygen throughout the contaminated soil, 2) to determine the rate at which indigenous microorganisms will degrade fuel when stimulated by oxygen rich soil gas, and 3) to evaluate the potential for sustaining these rates of biodegradation until fuel contamination is remediated below regulatory standards.

If above-ground bioventing proves to be feasible at this site, pilot test data could be used to design a full-scale remediation system and to estimate the time required for site cleanup. An added benefit of the pilot testing is that a significant amount of the fuel contamination should be biodegraded during the one year pilot test since the testing will involve treatment of approximately 100 cubic yards of the most contaminated soils on the site.

Additional background information on the development and recent success of the bioventing technology for *in situ* treatment is found in the attached document entitled "Test Plan and Technical Protocol for a Field Treatability Test for Bioventing". This protocol document will also serve as an ancillary reference for pilot test designs and detailed procedures which will be used during the test.

2.0 SITE DESCRIPTION

Soils for the above-ground bioventing pilot test will be obtained from petroleum-contaminated soils in the bermed area around Tank 141 that have resulted from historical leakage from flanges and valves. It is anticipated that the pilot test will be conducted at the fire protection training area, Installation Restoration Program (IRP) Site No. 2.

2.1 Site Location and History

Aboveground storage tank (AST) 141 contains No. 6 fuel oil and is secondarily contained by a soil berm. Over a period of several years leaks, from flanges and

valves have contributed to contamination of soils within the bermed area. Approximately 100 cubic yards of contaminated soils will be excavated and transported to IRP Site 2.

The IRP Site 2 fire protection training area is located on the southern part of the base, north of Perimeter Road (Figure 2.1). Two burn pits used for fire training activities include an old location of a mockup of an aircraft fuselage (burn pit A), and a concrete-lined burn pit recently used for fire protection training (burn pit B). A drainage and collection system serves to collect unburned fuel from the two burn areas, which is conveyed to two concrete-lined oil-water separators by underground cast iron pipelines. The concrete-lined burn pit B is approximately 80 feet in diameter.

2.2 Site Geology

Soils under lying the Tank 141 area consist of silty loams overlaying clays. The fine grain nature of the soil and the shallow depths to ground water suggest that in-situ bioventing would not be an appropriate remediation technology at this site, due to the low air permeability of fine-grain, wet soils. The objective of this pilot test will be above-ground bioventing treatment of the excavated soils to aid in air distribution, drying, and subsequent bioremediation of petroleum-contaminated soils.

The bermed area around Tank 141 contains a surface layer of rock, primarily clean 1-inch limestone, and some sand. These materials will be excavated with the contaminated silts and clays and added to the pilot test pile. These coarse materials should improve the air permeability of the soils.

Soils underlying IRP Site 2 consist of a brown, tan, or gray clay with iron staining. Grain size analyses indicate that site soils consist primarily of silt and clay with very little sand (98% passing the 200-mesh sieve). Shale bedrock was encountered at depths ranging from 15 to 17 feet below ground surface (reference?).

Ground water is encountered at a depth of approximately 2 to 4 feet across IRP Site 2. Water level measurements conducted on three monitoring wells at IRP Site 2 in March, 1989 indicate that ground water flow is towards the southwest with a gradient of approximately 0.07 ft/ft. However, water level data from November, 1988 indicated that ground water flow was to the northwest. Therefore, the ground water flow direction at this site is considered to be variable.

2.3 Soil Contaminants

Tank 141 contains No. 6 fuel oil which consists primarily of heavier hydrocarbon chains (C_{14} - C_{18}). Because of the mixing that will occur during excavation and transportation of soils and construction of the pilot test pile, it is difficult to estimate the average hydrocarbon concentrations that will be present in the pile. Soil sampling, as discussed in Section 3.2.1 of this Work Plan, will more accurately quantify the hydrocarbon concentrations of the test pile.

IRP Site 2 has residual contaminants from fire training activities over the years. The primary contaminants on this site are fuel residuals and possible free product in

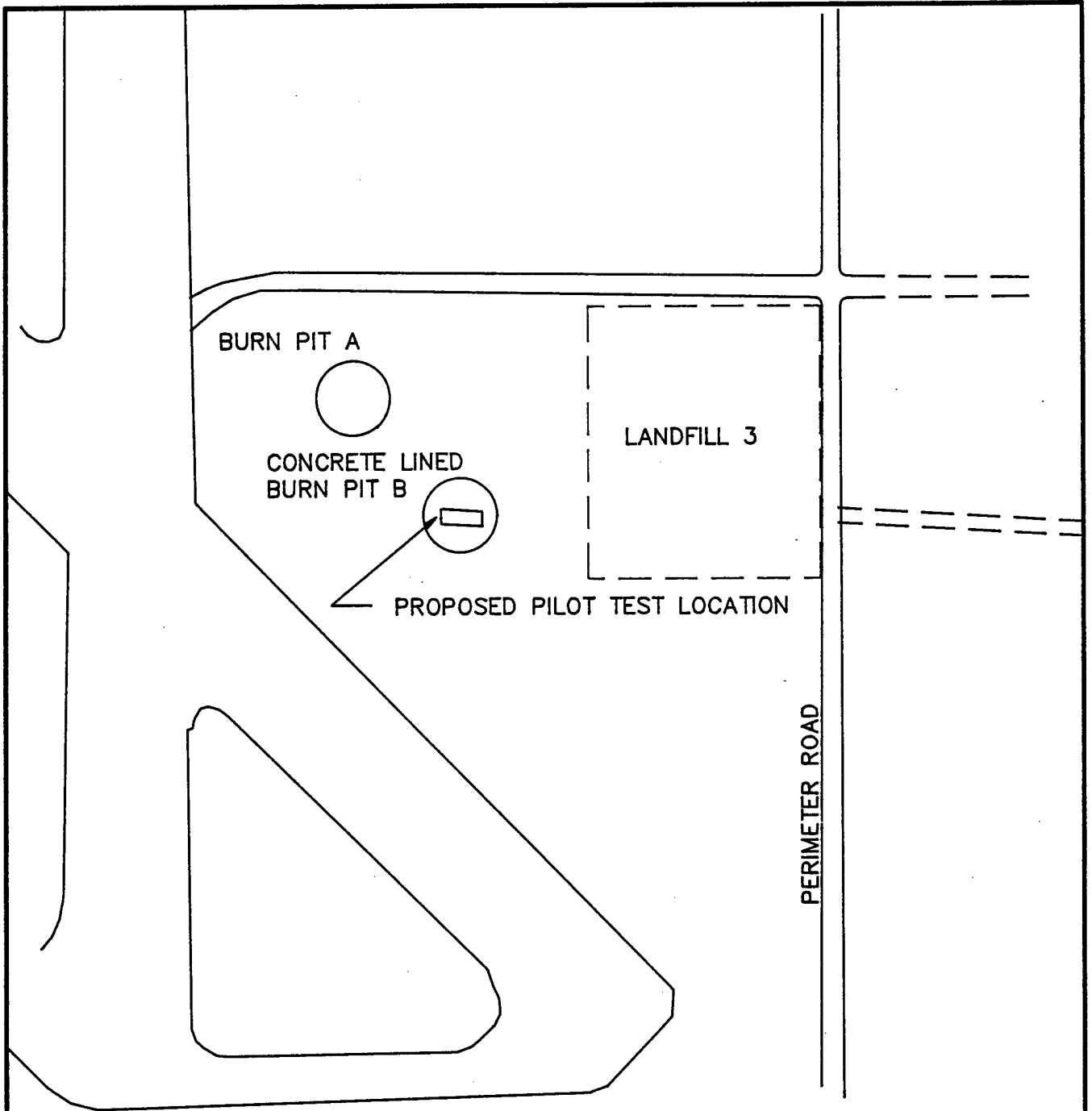
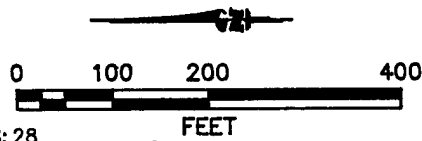

FIGURE 2.1
SITE LOCATION

WHITEMAN AFB, MISSOURI



26811-02, 09/23/92 at 08:28

ENGINEERING-SCIENCE, INC.
Denver, Colorado



fine grain soils between the ground surface and the water table. No analytical data has been gathered to date from within the fuel-contaminated soils of the two burn pits. A soil gas investigation was conducted in November, 1988 that encountered two areas of anomalously high total hydrocarbons in soil gas. Analyses of ground water from three shallow monitoring wells at IRP Site 2 encountered detectable concentrations of chlorinated solvents. Visual examination of the IRP Site 2 area during previous studies have noted surficial contamination and fuel odor in the vicinity of the burn pits, and along a nearby drainage ditch.

The above ground bioventing test pile will be created at burn pit B which is concrete lined. Additionally a drainage and collection system that drains to a concrete-lined oil/water separator serves the site. Therefore, there is little potential for impacts to the soils at IRP Site 2 due to the bioventing pilot test.

3.0 SITE SPECIFIC ACTIVITIES

The purpose of this section is to describe the work that will be performed by ES at Whiteman AFB. Activities that will be performed include constructing an above-ground bioventing test cell at IRP Site 2, conducting a respiration test, measuring oxygen distribution in the operating bioventing pile, and installation of a long-term above-ground bioventing system for treatment of petroleum-contaminated soils. The pilot testing will last for 1 year. Soil and soil gas sampling procedures and the blower configuration that will be used to inject air into contaminated soils are also discussed in this section. Specific sections of the bioventing field treatability protocol document are referenced as appropriate.

3.1 Location and Construction of Bioventing Pile

The bioventing pile test cell will be constructed on the concrete-lined surface of Burn Pit B at the fire protection training area, as shown on Figure 3.1. The pile will consist of approximately 100 cubic yards of petroleum contaminated soils. The source of the soils will be the Tank 141 bermed area.

The bioventing pile will be constructed as shown on Figure 3.1. The pile will be covered with plastic sheeting to provide a control of volatile organic emissions, as well as control of air flow throughout the pile. Four-inch diameter perforated polyvinyl chloride (PVC) drain pipes will be placed horizontally in the pile during construction as shown on Figure 3.1, to provide a manifold for distribution of air into the covered pile. Three vent pipes, two injection and one exhaust, will be installed to provide sufficient aeration of the soil. A blower system will be installed on the vent pipes to provide injection of air into the pile. Two soaker hoses will be placed near the top of the pile to distribute water and nutrient solutions as shown on Figure 3.1.

3.2 Soil and Gas Sampling

3.2.1 Soil Samples

Three composite soil samples will be collected from the bioventing test pile at the initiation of the test. Each sample will be composited from soil collected with a hand auger at three locations and three depths within the center of the pile. Each

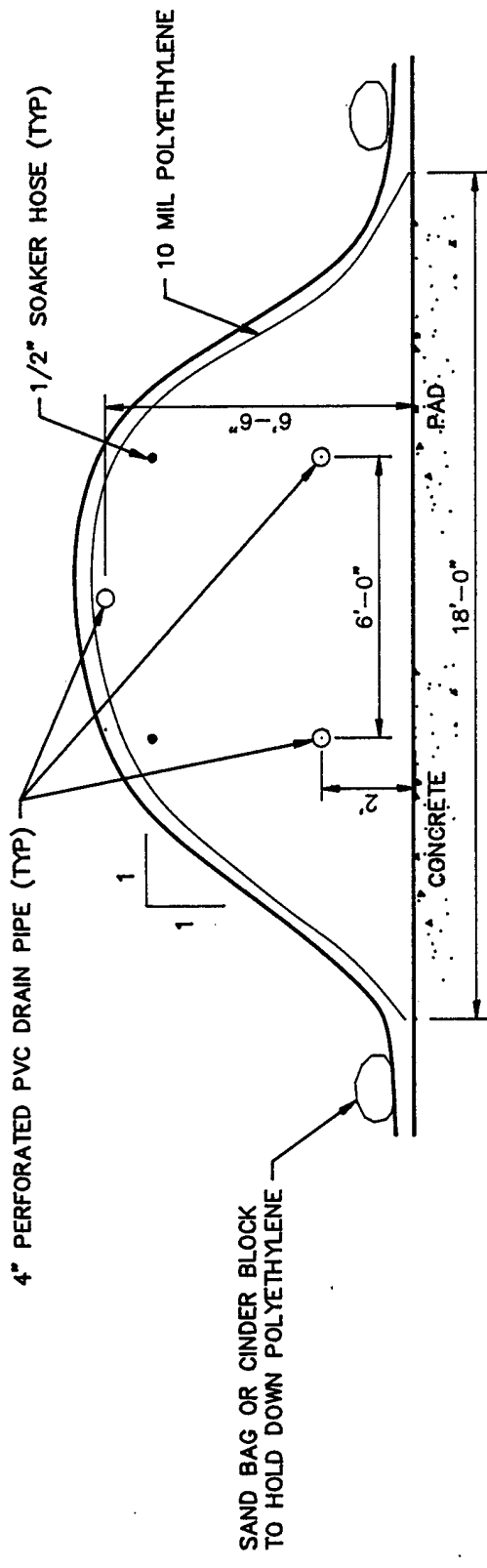

SECTION

SCALE: 1" = 4'-0"

NOTE:
 SOLID 4 INCH PVC PIPE SHOULD STICK OUT OF PLASTIC COVER APPROX 4 FEET ON INJECTION AND OUTLET ENDS AND EXTEND INTO SOIL PILE APPROX 5 FEET. 4 INCH PVC DRAIN PIPE WILL BE WELDED TO SOLID PIPE AND WILL BE USED FOR AIR INJECTION TO SUPPLY OXYGEN TO PILE.

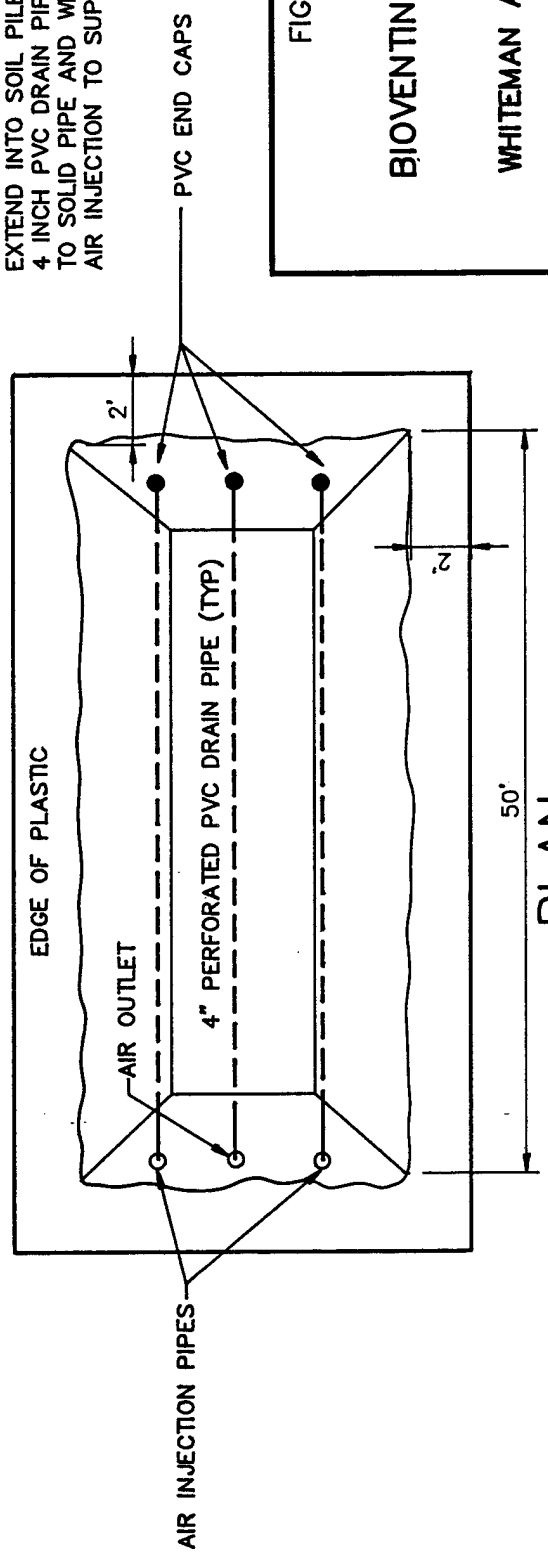

PLAN

SCALE: NTS

FIGURE 3.1

BIOVENTING TEST PILE

WHITEMAN AFB, MISSOURI

ENGINEERING-SCIENCE, INC.
 Denver, Colorado

ES

composite will be representative of one-third of the length of the bioventing pile. Soil samples will be analyzed for total recoverable petroleum hydrocarbons (TRPH), benzene, toluene, ethylbenzene, and xylenes (BTEX), soil moisture, pH, particle sizing, alkalinity, total iron, and nutrients.

Soil samples will be placed into glass sample containers immediately upon blending the composited sample. Soil samples will be labeled following the nomenclature specified in the protocol document (Section 5), wrapped in plastic, and placed in an ice chest for shipment. A chain-of-custody form will be filled out and the ice chest shipped to the Engineering-Science (ES) laboratory in Berkeley, California for analysis. This laboratory has been audited by the U.S. Air Force and meets all quality assurance/quality control and certification requirements for the State of California.

Final soil sampling of the pile will be performed after one year of operation of the pilot test to assist in quantifying the removal of hydrocarbons from the soil, and to evaluate the biodegradation of BTEX compounds in relation to total TRPH.

3.2.2 Soil Gas Sampling

A total hydrocarbon vapor analyzer (see protocol document Section 4.5.2) will be used for real-time monitoring of hydrocarbon concentrations in the exhaust from the bioventing pile. Initial and final soil gas samples will be collected in Summa[®] canisters from the pile exhaust manifold and from two soil gas probes located along the center line of the bioventing pile after verification of oxygen depleted air in the middle of the pile. These soil gas samples will be used to predict potential air emissions and to determine the reduction in BTEX and total volatile hydrocarbons (TVH) during the one year test.

Soil gas samples will be placed in a small ice chest and packed with foam pellets to prevent excessive movement during shipment. Samples will not be sent on ice to prevent condensation of hydrocarbons. A chain-of-custody form will be filled out and the ice chest shipped to the Air Toxics laboratory in Rancho Cordova, California for analysis.

3.3 Blower System

A one horsepower regenerative blower capable of injecting air at up to 1.8 psi will be used to provide oxygen for enhanced fuel biodegradation. Air injection rates will be controlled to minimize volatile organic emissions while insuring adequate oxygen for biodegradation. Figure 3.2 provides a schematic of the blower system.

3.4 Oxygen Distribution Test

The objective of the oxygen distribution test is to determine the extent of the bioventing pile that is effectively aerated with the blower system. Following construction and covering of the bioventing pile, the distribution of oxygen will be measured in the pile with soil gas probes. The blower will remain off for initial measurements to verify that active air injection will be required to enhance biodegradation in the soil pile. A period of 1 to 3 days after covering the pile may be necessary for soil air to reach a concentration approaching 0% oxygen in the

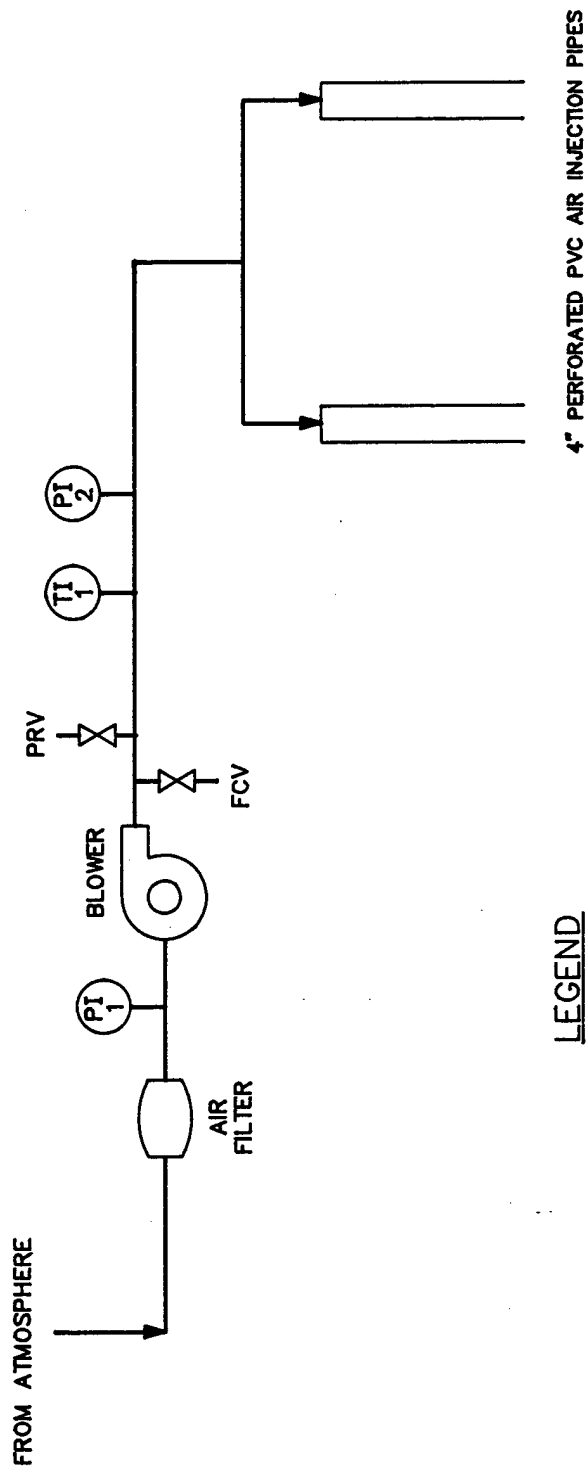

LEGEND

- (PI₁) PRESSURE INDICATOR
- (TI₁) TEMPERATURE INDICATOR
- FCV FLOW CONTROL VALVE
- PRV PRESSURE RELIEF VALVE

FIGURE 3.2

**BLOWER SYSTEM
INSTRUMENTATION DIAGRAM
FOR AIR INJECTION**

WHITEMAN AFB, MISSOURI

ENGINEERING-SCIENCE, INC.
Denver, Colorado

ES

middle of the pile due to microbial uptake of oxygen related to petroleum biodegradation. Oxygen, carbon dioxide and volatile hydrocarbons will be measured at three locations along the centerline and in the middle of the pile as described in the monitoring point discussion in the protocol document (Section 4.5). A sample of the soil gas will be collected with a Summa® canister from two points along the centerline of the pile immediately following verification of oxygen-depleted air in the middle of the pile.

A cross-sectional oxygen profile will be established at 10 feet, 25 feet, and 40 feet from the air injection end of the bioventing pile (Figure 3.3). Soil gas probes will be inserted through the plastic liner and into the soil pile in a manner to provide approximately 5 representative soil gas measurements along each profile. The location and depth of each soil gas measurement will be recorded in the field logbook. Oxygen profile measurements will be performed at 2 hours, 6 hours, and 24 hours following the start-up of the blower system.

In addition to soil gas measurements, the exhaust air from the pile will be sampled and analyzed for oxygen, carbon dioxide, and volatile hydrocarbons 24 hours after initial start-up of the blower system. At the same time, an exhaust gas sample will be collected in a Summa® canister for laboratory analysis.

3.5 Respiration Test

The objective of the respiration test is to determine the rate at which soil bacteria degrade petroleum hydrocarbons. Respiration tests will be performed at three locations within the center of the bioventing pile. At the end of the oxygen distribution test described in Section 3.5, three soil probes will be installed in the middle of the pile, and the air injection blower will be shut off. Oxygen and carbon dioxide levels from the three soil gas monitoring points will be measured for 48 to 72 hours. The decline in oxygen and increase in carbon dioxide concentrations over time will be used to estimate rates of bacterial degradation of fuel residuals.

Helium will not be used to estimate oxygen diffusion rates in the bioventing pile. The presence of atmospheric oxygen in the space surrounding the bioventing pile negates the purpose of this test. The only potential for oxygen diffusion is from the atmosphere into the pile, and not vice-versa.

3.6 Installation of Long-Term System

A long-term above-ground bioventing system will also be installed. We request that the base electrician provide a power pole with a 230V/single phase/30 amp breaker, one 230V receptacle, and two 110V receptacles. An electrician subcontracted to ES will be brought on base to assist in wiring the blowers to line power. The blower will be housed in a small, prefabricated shed to provide protection from the weather. The system will be in operation for one year, and ES personnel will be onsite in April and October 1993 to conduct respiration tests to monitor the long-term performance of this bioventing system. Weekly system checks will be performed by Whiteman AFB personnel. If required, major maintenance of the blower unit will be performed by ES personnel. Detailed blower system information and a maintenance schedule will be included in the

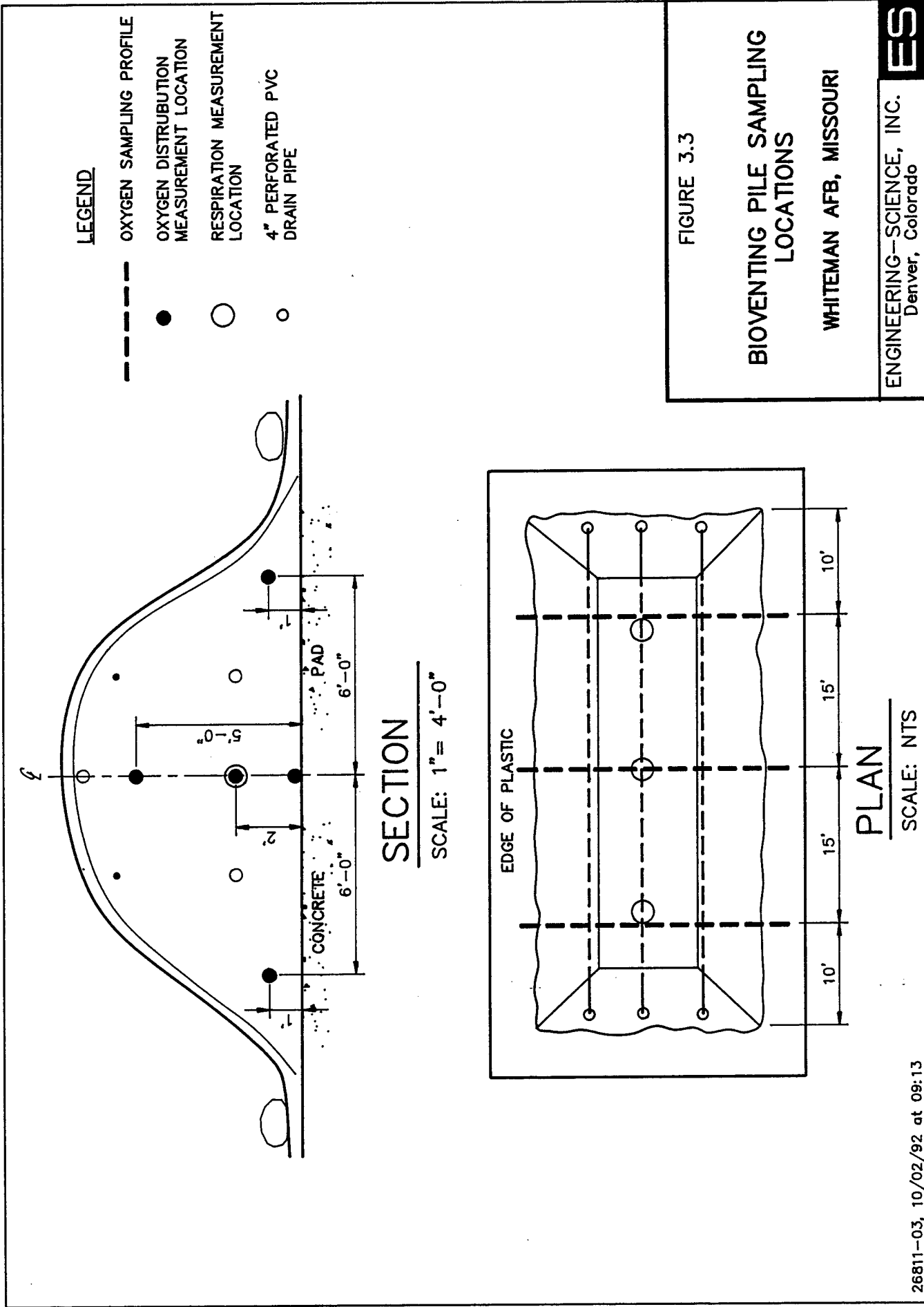

Operation and Maintenance (O&M) manual provided to the base. More detailed information regarding the test procedures can be found in the protocol document.

4.0 EXCEPTIONS TO PROTOCOL PROCEDURES

The procedures that will be used to measure the air permeability of the soil and *in situ* respiration rates are described in Sections 4 & 5 of the attached protocol document. Exceptions to the protocol are anticipated due to the implementation of an above-ground bioventing system rather than an *in situ* system. The exceptions are explained in detail within Sections 3.5 and 3.6 of this Work Plan.

5.0 BASE SUPPORT REQUIREMENTS

5.1 Test Preparation

The following base support is needed prior to the arrival of the ES test team:

- Confirmation of regulatory approval for the pilot test.
- Construction of the bioventing test cell.
- Installation of a new power line to a new power pole adjacent to the concrete-lined Burn Pit B of the Fire Training Area. The pole should include a 230V/single phase/30 amp service, a breaker box with one 230V receptacle, and two 110V receptacles and be located within 20 feet of the air injection inlet pipe at the end of the soil pile.
- Provide any paperwork required to obtain gate passes and security badges for approximately three ES employees. Vehicle passes will be needed for two trucks.

During the initial three week pilot test the following base support is needed:

- Twelve square feet of desk space and a telephone in a building located as near to the site as practical.
- The use of a fax machine for transmitting 15 to 20 pages of test results.

During the one year extended pilot test:

- Check the blower system once a week to ensure that it is operating and to record the air injection pressure. ES will provide a brief training session on this procedure.
- If the blower or motor stops working, notify Mr. Brian Blicher, Mr. Doug Downey or Ms. Gail Saxton, ES-Denver, (303) 831-8100, or Mr. Jim Williams of the AFCEE, (800) 821-4528.
- Arrange site access for an ES technician to conduct respiration tests at approximately six months and at one year after the initial pilot test.

6.0 PROJECT SCHEDULE

The following schedule is contingent upon timely approval of this pilot test work plan.

Event	Date
Draft Test Work Plan to AFCEE/Whiteman	6 October 1992
Approval to Proceed	14 October 1992
Begin Pilot Test	26 October 1992
Complete Initial Pilot Test	6 November 1992
Interim Results Report	18 December 1992
Respiration Test	April 1993
Final Respiration Test	October 1993

7.0 POINTS OF CONTACT

Marvin Eaves
351 CSG/CEV
Whiteman AFB, MO 63305-5000
(816) 687-6263

Major Ross Miller/Mr. Jim Williams
AFCEE/ESR
Brooks AFB, TX 78235-5000
(800) 821-4528 ext. 282, 293

Mr. Doug Downey
Engineering-Science, Inc.
1700 Broadway, Suite 900
Denver, CO 80290
(303) 831-8100
Fax (303) 831-8208