

# LOAN DOCUMENT

PHOTOGRAPH THIS SHEET

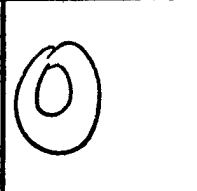

INVENTORY

DTIC ACCESSION NUMBER

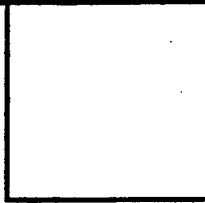

LEVEL

Part 1

Final Bioventing Pilot Test Work Plan...

DOCUMENT IDENTIFICATION

3ep 92

**DISTRIBUTION STATEMENT A**  
Approved for Public Release  
Distribution Unlimited

DISTRIBUTION STATEMENT

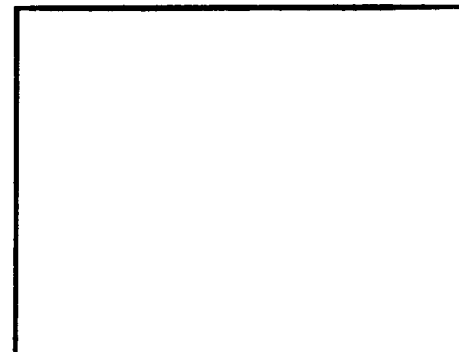

DATE ACCESSIONED

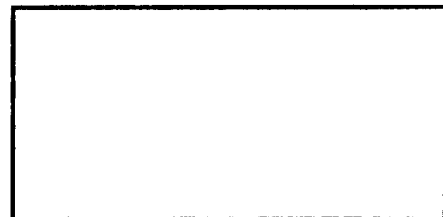

DATE RETURNED

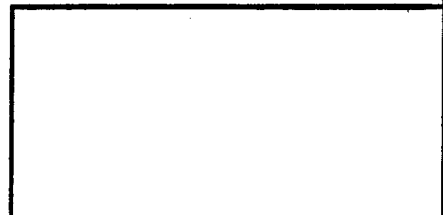

REGISTERED OR CERTIFIED NUMBER

ACCESSION FOR	
NTIS	ORAS <input checked="" type="checkbox"/>
DTIC	TRAC <input type="checkbox"/>
UNANNOUNCED	<input type="checkbox"/>
JUSTIFICATION	
BY	
DISTRIBUTION/	
AVAILABILITY CODES	
DISTRIBUTION	AVAILABILITY AND/OR SPECIAL
A-1	

DISTRIBUTION STAMP

DTIC QUALITY INSPECTED &

20001130 040

DATE RECEIVED IN DTIC

PHOTOGRAPH THIS SHEET AND RETURN TO DTIC-FDAC

H  
A  
N  
D  
L  
E  
  
W  
I  
T  
H  
  
C  
A  
R  
E

# PART I

## FINAL BIOVENTING PILOT TEST WORK PLAN

*For*

**BASE EXCHANGE SERVICE STATION  
UNDERGROUND STORAGE TANK AREA  
Vandenberg Air Force Base, California**

*Prepared for*

**AIR FORCE CENTER FOR  
ENVIRONMENTAL EXCELLENCE  
Brooks Air Force Base, Texas**

*and*

**730 CES / CEVR VANDENBERG AFB, California**

SEPTEMBER 1992

*Prepared by*

**ENGINEERING-SCIENCE, INC.  
DESIGN ■ RESEARCH ■ PLANNING  
199 SOUTH LOS ROBLES AVENUE ■ P.O. BOX 7056 ■ PASADENA ■ CALIFORNIA 91109**

**ES ENGINEERING-SCIENCE**

AQM01-01-0362

### DEFENSE TECHNICAL INFORMATION CENTER REQUEST FOR SCIENTIFIC AND TECHNICAL REPORTS

Title AFCEE Collection

**1. Report Availability** (Please check one box)

- This report is available. Complete sections 2a - 2f.
- This report is not available. Complete section 3.

**2a. Number of Copies Forwarded**

1 each

**2b. Forwarding Date**

July/2000

**2c. Distribution Statement** (Please check ONE box)

DoD Directive 5230.24, "Distribution Statements on Technical Documents," 18 Mar 87, contains seven distribution statements, as described briefly below. Technical documents MUST be assigned a distribution statement.

- DISTRIBUTION STATEMENT A: Approved for public release. Distribution is unlimited.
- DISTRIBUTION STATEMENT B: Distribution authorized to U.S. Government Agencies only.
- DISTRIBUTION STATEMENT C: Distribution authorized to U.S. Government Agencies and their contractors.
- DISTRIBUTION STATEMENT D: Distribution authorized to U.S. Department of Defense (DoD) and U.S DoD contractors only.
- DISTRIBUTION STATEMENT E: Distribution authorized to U.S. Department of Defense (DoD) components only.
- DISTRIBUTION STATEMENT F: Further dissemination only as directed by the controlling DoD office indicated below or by higher authority.
- DISTRIBUTION STATEMENT X: Distribution authorized to U.S. Government agencies and private individuals or enterprises eligible to obtain export-controlled technical data in accordance with DoD Directive 5230.25, Withholding of Unclassified Technical Data from Public Disclosure, 6 Nov 84.

**2d. Reason For the Above Distribution Statement** (in accordance with DoD Directive 5230.24)

**2e. Controlling Office**

HQ AFCEE

**2f. Date of Distribution Statement Determination**

15 Nov 2000

**3. This report is NOT forwarded for the following reasons.** (Please check appropriate box)

- It was previously forwarded to DTIC on \_\_\_\_\_ (date) and the AD number is \_\_\_\_\_
- It will be published at a later date. Enter approximate date if known. \_\_\_\_\_
- In accordance with the provisions of DoD Directive 3200.12, the requested document is not supplied because: \_\_\_\_\_

**Print or Type Name**

Laura Peña

**Signature**

Laura Peña

**Telephone**

210-536-1431

(For DTIC Use Only)

**AQ Number** M01-01-0362

**PART 1**  
**FINAL BIOVENTING PILOT TEST WORK PLAN FOR**  
**BASE EXCHANGE SERVICE STATION UNDERGROUND STORAGE**  
**TANK AREA**  
**VANDENBERG AFB, CALIFORNIA**

**Prepared for:**

**AIR FORCE CENTER FOR ENVIRONMENTAL EXCELLENCE**  
**BROOKS AFB, TEXAS**  
**AND**  
**730 CES/CEVR VANDENBERG AFB, CALIFORNIA**

**SEPTEMBER 1992**

**Prepared by:**

**ENGINEERING-SCIENCE, INC.**  
**199 S. LOS ROBLES AVENUE**  
**PASADENA, CALIFORNIA 91101**

## TABLE OF CONTENTS

	<u>Page</u>
1.0 INTRODUCTION.....	1
2.0 SITE DESCRIPTION.....	1
2.1 Site Location and History.....	2
2.2 Site Geology.....	2
2.3 Site Contaminants.....	4
3.0 SITE-SPECIFIC ACTIVITIES.....	4
3.1 Location and Construction of Vent Well and Monitoring Points.....	4
3.2 Handling of Drill Cuttings.....	6
3.3 Sampling.....	6
3.3.1 Soil Samples.....	6
3.3.2 Soil Gas Samples.....	9
3.4 Blower System.....	9
3.5 In Situ Respiration Test.....	11
3.6 Air Permeability Test.....	11
4.0 INSTALLATION OF EXTENDED PILOT TEST SYSTEM.....	11
5.0 EXCEPTIONS TO PROTOCOL PROCEDURES.....	12
6.0 BASE SUPPORT REQUIREMENTS.....	12
7.0 PROJECT SCHEDULE.....	13
8.0 POINTS OF CONTACT.....	13
9.0 REFERENCES.....	14

## FIGURES

2-1 Site Location.....	3
3-1 Proposed Vent/Monitoring Point Locations.....	5
3-2 Injection/Vent-Well Construction Details.....	7
3-3 Monitoring Point Construction Details.....	8
3-4 Blower System Instrumentation Diagram for Air Injection.....	10

# BIOVENTING PILOT TEST WORK PLAN FOR BASE EXCHANGE SERVICE STATION UNDERGROUND STORAGE TANK AREA VANDENBERG AFB, CALIFORNIA

## 1.0 INTRODUCTION

This pilot test work plan presents the scope of an *in situ* enhanced biological degradation, or "bioventing", pilot test for treatment of gasoline-contaminated soils at the Base Exchange Service Station (BXSS), Underground Storage Tank (UST) Area, Vandenberg Air Force Base (AFB), California. The pilot test has three primary objectives: 1) to assess the potential for supplying oxygen throughout the contaminated soil interval, 2) to determine the rate at which indigenous microorganisms will degrade fuel when stimulated by oxygen-rich soil gas, and 3) to evaluate the potential for sustaining these rates of biodegradation until fuel contamination is remediated to below the regulatory standards.

The pilot test will be conducted in two phases. The initial phase of the project will consist of construction of a vent well and monitoring points, an *in situ* respiration test, and an air permeability test. This initial testing is expected to take approximately one week. During the second phase, a bioventing system will be installed and monitored over a 1-year period.

If bioventing proves to be feasible at this site, pilot test data will be used to design a full-scale bioventing remediation system and to estimate the time required for site cleanup. An added benefit of the pilot test at the BXSS UST Area is that a significant amount of the fuel contamination should be biodegraded during the 1-year pilot test, as the testing will take place within the most contaminated soils on the site.

Background information on the development and recent success of the bioventing technology is found in the attached document entitled "Test Plan and Technical Protocol for a Field Treatability Test for Bioventing" (Hinchee, et al., Engineering-Science Inc. for U.S. Air Force center for Environmental Excellence 1992). This protocol document will also serve as a primary reference for the pilot test well design and the procedures to be used during the test.

## 2.0 SITE DESCRIPTION

The information presented in this section was obtained from the report titled "Site Assessment Report for the Base Exchange Service Station, Site Characterization, (Volume I) March 1992 prepared by the U.S. Department of the Interior Bureau of Land Reclamation.

## 2.1 Site Location and History

The BXSS is located at the corner of California Boulevard and Herado Avenue in the north central part of the cantonment area at Vandenberg Air Force Base (VAFB) (Figure 2-1). The BXSS consists of the main office building with attached service bays for automotive repair. The BXSS has recently installed four USTs and the associated piping for storage of different grades of unleaded gasoline. In addition to the USTs, an active pump island is present as is an abandoned pump island.

In 1967, four steel 10,000 gallon single-walled underground fuel tanks and associated piping were installed at the BXSS along with a steel 250 gallon single-walled underground waste oil storage tank. These USTs contained various grades of leaded and unleaded gasoline and waste oil from operation of the service station.

In 1985, two 10,000 gallon fuel tanks installed in 1967 were replaced with two state-of-the-art, double-walled fiberglass underground storage tanks and associated piping. The two remaining 10,000 gallon fuel tanks installed in 1967 were replaced in 1991 with two approved double-walled fiberglass USTs. The 250 gallon waste oil tank was also removed in 1991.

Excavation and replacement of the "old" 10,000 gallon USTs revealed the presence of soil contaminated with fuel hydrocarbons in the immediate vicinity of the USTs. Only a limited amount of contaminated soil was excavated during removal of these USTs and the site was back-filled with clean material and covered with asphalt or concrete. The presence of contamination at the BXSS required a site characterization to determine the type and extent of contamination present at the site. The results of this characterization are described in the March 1992 Bureau of Land Reclamation Site Assessment Report.

## 2.2 Site Geology

Bioventing technology is applied to the unsaturated soils above the aquifer. Groundwater is encountered at a depth of approximately 8.5 feet and flows in a northeasterly direction across the site at a gradient of approximately 0.019 foot per foot (ft/ft). Boring logs from previous investigations indicate poorly graded, fine to medium sands extend from ground surface to a fat clay layer at a depth of 14 to 15 feet. Another fat clay layer is encountered at a depth of 24 feet. Both clay layers are approximately 2 to 4 feet thick. The lower clay layer appears more laterally extensive, as the uppermost clay layer is not encountered in borings east of the USTs. Between and below the two clay layers are interbedded fine to medium sands, silty sands, clay sands, and lean clays. The depth to bedrock at the site is approximately 60 feet.

The nature of the soils at this site appear to be suited to bioventing treatment. Soil vapor monitoring points will be positioned in five locations in the fine to medium sand at a depth of approximately 6.5 feet to study the subsurface oxygen distribution during the pilot test.

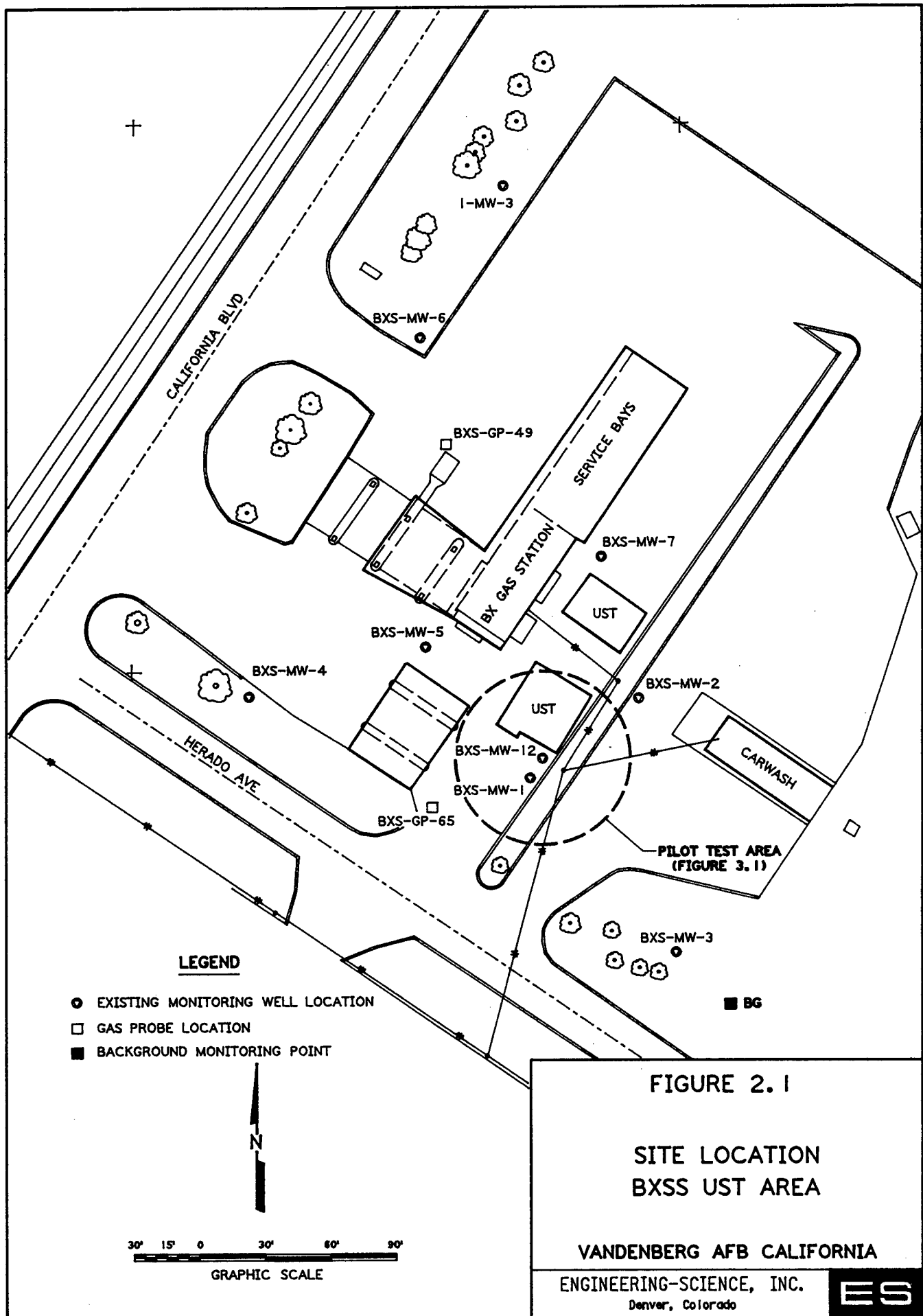

### 2.3 Site Contaminants

In a previous study approximately 120 soil samples and 15 water samples were collected and analyzed for gasoline, BTEX, solvents, and automotive metals (Pb, Sn, Cr, Cd, Zn).

The results of these analyses indicate that gasoline and BTEX contamination is centered on the removed UST's. This contamination has migrated downward under the influence of gravity until it reached the groundwater table (10 ft below ground surface) where it has spread horizontally across much of the site. Maximum total petroleum hydrocarbon (TPH) concentrations of 22,000 ppm in the soil at BXS-GP-65 and 120,000 ppm in the groundwater at BXS-MW-2 were found slightly to the south and east respectively of the removed UST location. Maximum BTEX concentrations for soil and water samples were in the same locations respectively.

Solvent contamination was in small isolated patches with soil samples measuring a maximum value of 8600 ppb for acetone at BXS-GP-49 and water samples measuring a maximum of 610 ppb for 1,2 DCA at BXS-MW-2. Metals analyses indicated only one sample which exceeded water board standards. This water sample from BXS-MW-2 exceeded California Regional Water Quality Control Board lead standards at 0.46 ppm. This lead is presumably due to leaded gasoline leakage from the UST's.

### 3.0 SITE-SPECIFIC ACTIVITIES

The purpose of this section is to describe the work that will be performed by Engineering-Science, Inc. (ES) at the UST Area. Activities that will be performed include siting and construction of five vapor monitoring points (MPs), an *in situ* respiration test, an air permeability test, and the installation of a long-term bioventing pilot test system at the UST Area. Soil and soil gas sampling procedures and the blower configuration that will be used to inject air (oxygen) into contaminated soils through the vent well are also discussed in this section. Pilot test activities will be confined to unsaturated soils remediation. No dewatering will take place during the pilot test. Existing monitoring well BXS-MW-12 will be used as primary air injection vent well (VW). Other monitoring wells which have a portion of their screened interval above the water table may be used as vapor MPs or to measure the composition of background soil gas.

#### 3.1 Location and Construction of Vent Well and Monitoring Points

A general description of criteria for siting a VW and MPs are included in the attached protocol. Figure 3-1 indicates the location of the VW (BXS-MW-12) and the proposed location of the MPs at this site. The final locations of these MPs may vary slightly from the proposed locations if significant fuel contamination is not observed in the boring for the MPs. Soils in this area are expected to be oxygen depleted (<2% oxygen), and increased biological activity should be stimulated by oxygen-rich soil gas ventilation during testing and full-scale operations.

Due to the composition of the soils at this site, the radius of venting influence around the central air-injection well is expected to be 30 to 40 feet. Four vapor MPs

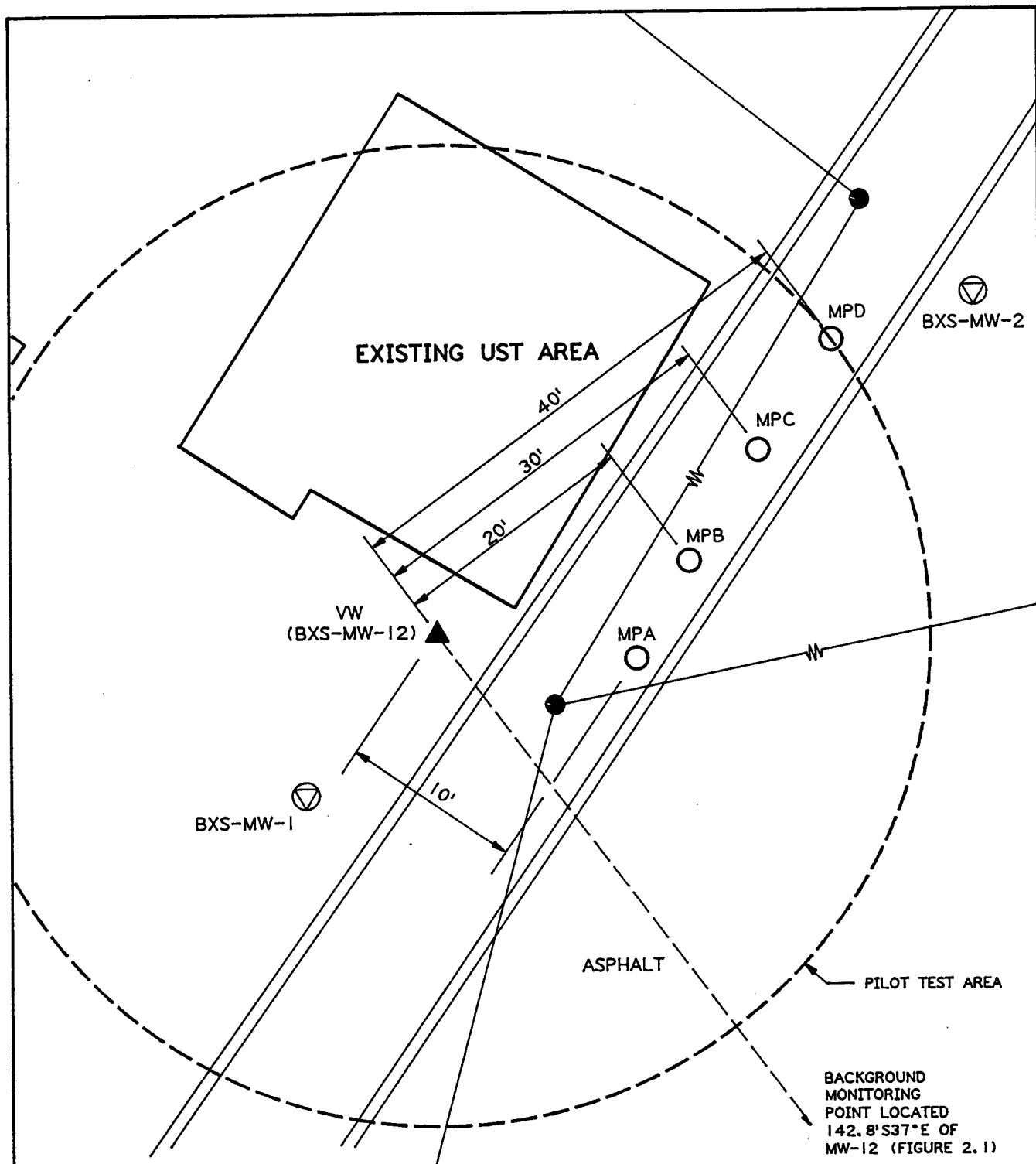

**LEGEND**

- VAPOR MONITORING POINT
- ▲ CENTRAL VENT WELL (AIR INJECTION)
- ⊙ EXISTING MONITORING WELL
- POWER POLE AND LINE
- BACKGROUND MONITORING POINT

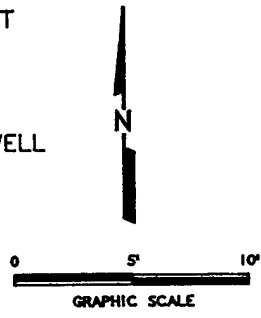

**FIGURE 3.1**  
**PROPOSED VENT/MONITORING POINT LOCATIONS**  
**BXSS UST AREA**  
**VANDENBERG AFB CALIFORNIA**  
**ENGINEERING-SCIENCE, INC.**  
 Denver, Colorado



(MPA, MPB, MPC, MPD) will be located within a 40-foot radius of the VW (Figure 3-1) in fuel contaminated soils. A fifth vapor MP will be located southeast of the UST Area, and will be used to measure background levels of oxygen and carbon dioxide and to determine if natural carbon sources are contributing to oxygen uptake during the in situ respiration test. Additional details of the in situ respiration test are found in Section 5.7 of the attached protocol document.

Because the depth to groundwater at the site is approximately 8.5 feet bgs, only single depth vapor MPs will be installed. The borings for probe installation will be drilled using hand auger drilling and sampling equipment. The boring will be approximately 3 inches in diameter. A typical single depth vapor MP installation for this site is shown in Figure 3-3. Soil gas oxygen and carbon dioxide concentrations will be monitored with a vapor probe installed at a depth of approximately 6.5 feet in each MP location. Monitoring will confirm the contaminated soil profile is receiving oxygen and will allow measurement of fuel biodegradation rates. The annular space above the probe will be sealed with a bentonite slurry. Several inches of bentonite pellets will be used to shield the probes filter pack from rapid infiltration of bentonite slurry additions. Additional details on MP construction are found in Section 4 of the protocol document.

### **3.2 Handling of Drill Cuttings**

Drill cuttings from all borings will be screened in the field with a total hydrocarbon vapor analyzer (see protocol document Section 4.5.2). Cuttings with detectable petroleum contamination will be collected in U.S. Department of Transportation (DOT)-approved containers, the containers labeled, and stored at the site. These drill cuttings will become the responsibility of Vandenberg AFB and will be handled in accordance with the current base procedures for ongoing remedial investigations. Cuttings with no detectable petroleum contamination will be spread on the ground surface within the pilot test area. This project is expected to generate less than 1-55-gallon drum of cuttings.

### **3.3 Sampling**

#### **3.3.1 Soil Samples**

Three soil samples will be collected from the pilot test area during the installation of the MPs. Sampling procedures will follow those outlined in the protocol document. One sample will be collected from the interval of highest apparent contamination in three of the borings for the MPs. Soil samples will be analyzed for the following;

2" DIA SCH 40 PVC  
HEADER SLOPED  
TO WELL

FROM BLOWER

CONCRETE COLLAR

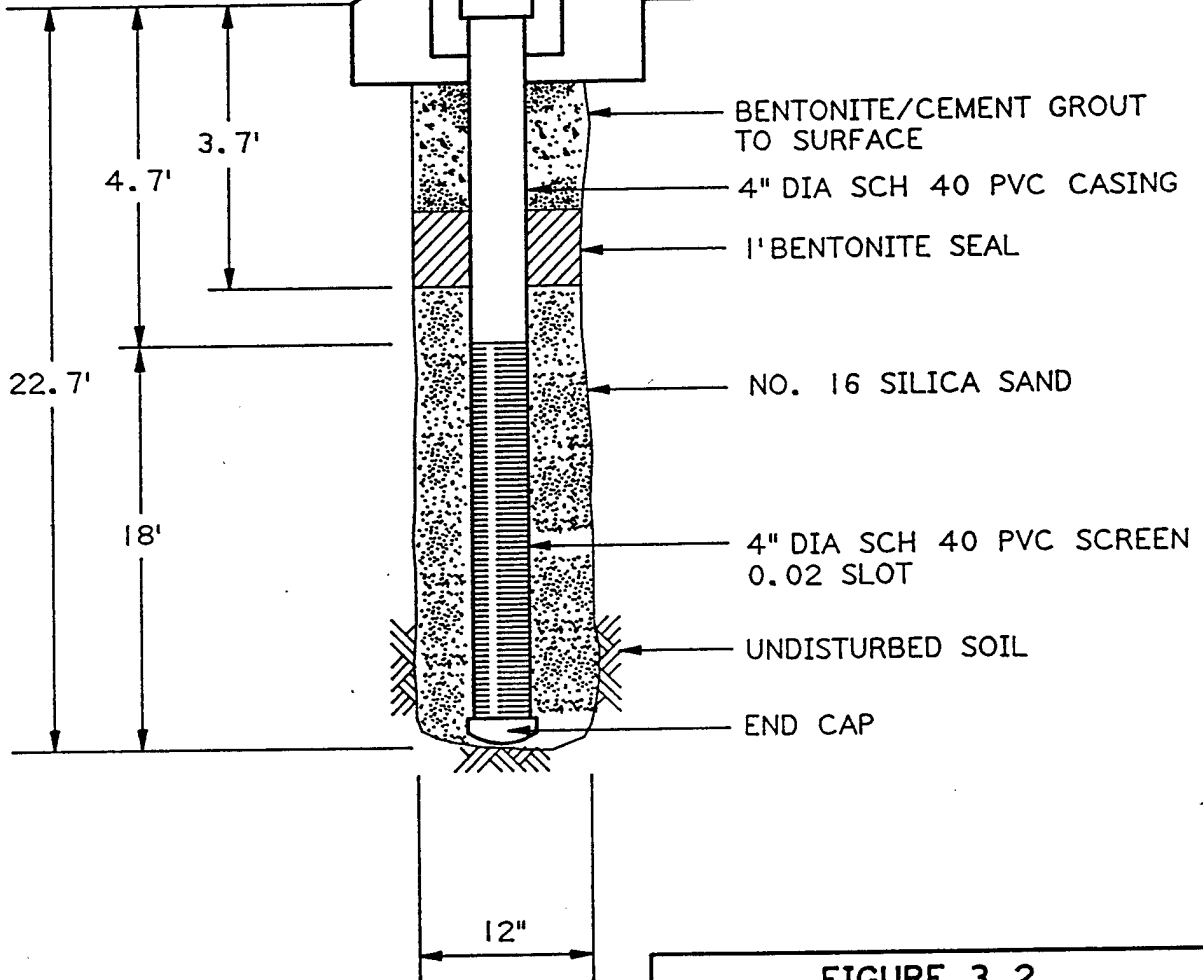

FIGURE 3.2

INJECTION/VENT WELL  
(BXS-MW-12)  
CONSTRUCTION DETAIL  
BXSS UST AREA

VANDENBERG AFB CALIFORNIA  
ENGINEERING-SCIENCE, INC.  
Denver, Colorado

ES

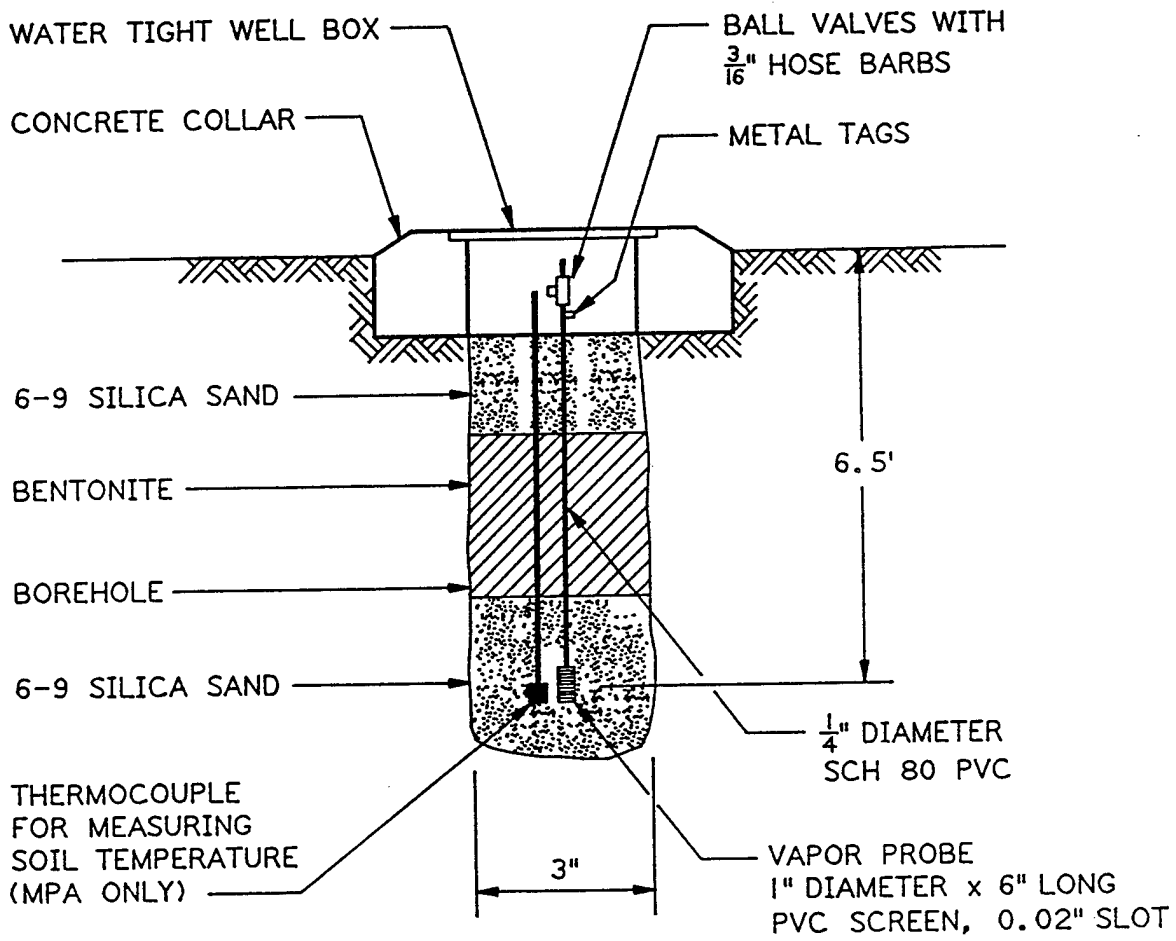

FIGURE 3.3

MONITORING POINT  
CONSTRUCTION DETAIL  
BXSS UST AREA

VANDENBERG AFB CALIFORNIA  
ENGINEERING-SCIENCE, INC.  
Denver, Colorado



<b>Analytical Parameter</b>	<b>Method</b>
Total recoverable petroleum hydrocarbons (TRPH)	E 418.1
Benzene, toluene, ethyl benzene, xylenes (BTEX)	SW8070
Soil moisture	SW846
pH	SW9045
Particle size	UCM
Alkalinity	A403
Total iron	SW7380
total kjeldahl nitrogen	E351.2
Total phosphorus	365.3

Samples for TRPH and BTEX analysis will be collected using an AMS® soil core sampler containing brass tube liners. Soil samples collected in the brass tubes for TRPH and BTEX analyses will be immediately trimmed and the ends sealed with Teflon sheets held in place by plastic caps. Soil samples collected for physical parameter analyses will be placed into glass sample jars or other appropriate sample containers specified in the bioventing field sampling plan. Soil samples will be labelled following the nomenclature specified in the protocol document (Section 5), wrapped in plastic, and placed in a cooler for shipment. A chain-of-custody form will be filled out, and the cooler shipped to the ES laboratory in Berkeley, California, for analysis. This laboratory has been audited by the Air Force and meets all quality assurance/quality control and certification requirements for the State of California.

### **3.3.2 Soil Gas Samples**

Prior to soil gas sampling, the VW and MPs will be purged using a one cubic feet per minute (CFM) pump. The purge volume will be three times the VW or MPs volume. Soil gas samples will be collected immediately upon completion of purging. Soil gas samples will be collected in SUMMA® canisters from the VW and from the MPs closest to and furthest from the VW in accordance with the Field Sampling Plan (ES, 1992). These samples will be analyzed for BTEX and total volatile hydrocarbons (TVH). Soil gas analytical results will be used to predict potential air emissions, to determine the reduction in BTEX and TVH during the 1-year test, and to detect migration of these vapors from the source area.

Soil gas sample canisters will be placed in a small cooler and packed with foam pellets to prevent excessive movement during shipment. Samples will not be sent on ice to prevent condensation of hydrocarbons. A chain of custody form will be filled out and the ice chest shipped to the Air Toxics laboratory in Rancho Cordova, CA for analysis.

### **3.4 Blower System**

A 1 horsepower regenerative blower capable of injecting 30 standard cubic feet per minute (scfm) at 2 psi will be used in conjunction with the VW to conduct the initial air permeability test and in situ respiration tests. Figure 3-4 is a schematic of

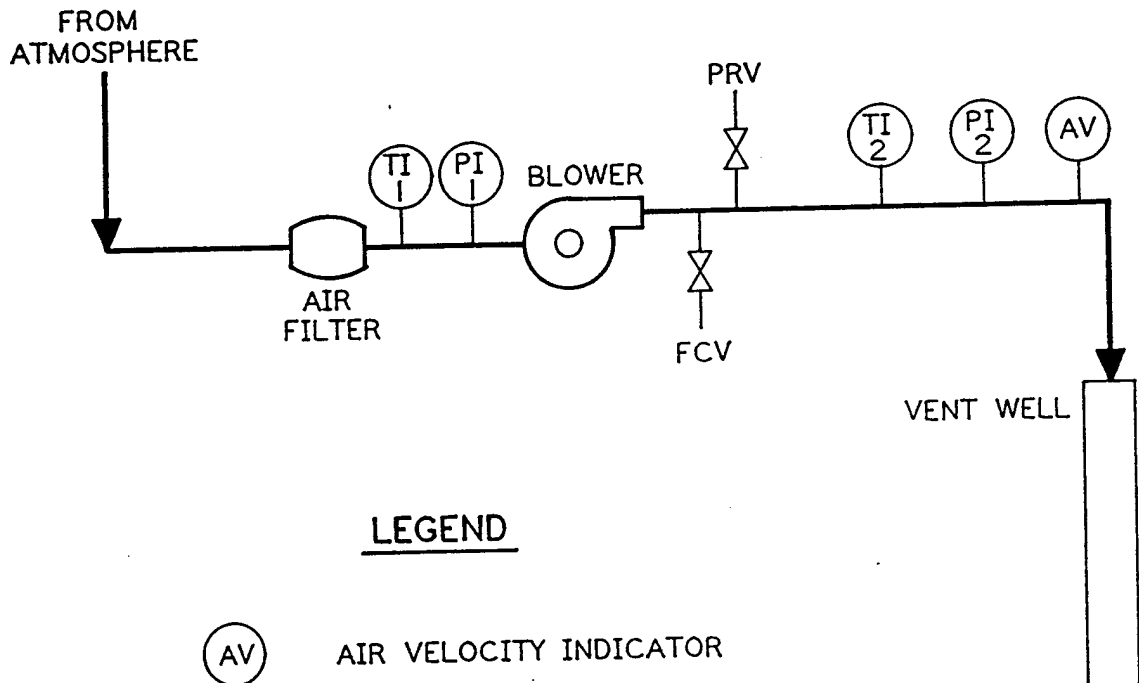

LEGEND

- (AV) AIR VELOCITY INDICATOR
- (TI) PRESSURE INDICATOR
- (TI) TEMPERATURE INDICATOR
- FCV FLOW CONTROL VALVE
- PRV PRESSURE RELIEF VALVE

FIGURE 3.4  
 BLOWER SYSTEM  
 INSTRUMENTATION DIAGRAM  
 FOR AIR INJECTION  
 BXSS UST AREA

VANDENBERG AFB CALIFORNIA

ENGINEERING-SCIENCE, INC.  
 Denver, Colorado



a typical air injection system used for pilot testing. The maximum power requirement anticipated for this pilot test is a 110 volt, single-phase, 15 amp service. Additional details on power supply requirements are described in Section 5.0, Base Support Requirements.

### **3.5 In Situ Respiration Test**

The objective of the in situ respiration test is to determine the rate at which soil bacteria degrade petroleum hydrocarbons. Respiration tests will be performed at the VW and every vapor probe and vent well where bacterial degradation of hydrocarbons is indicated by low oxygen levels and elevated carbon dioxide concentrations in the soil gas. Air will be injected into the VW and MPSs for a 20-hour period to oxygenate local contaminated soils. At the end of the 20-hour air injection period, the air supply will be cut off, and oxygen and carbon dioxide levels will be monitored for the following 48 to 72 hours. The decline in oxygen and increase in carbon dioxide concentrations over time will be used to estimate rates of bacterial degradation of fuel residuals. Helium will also be injected at one point to estimate oxygen diffusion rates in site soils. This estimated rate of diffusion will be used as a comparison with the measured rate of oxygen consumption.

### **3.6 Air Permeability Test**

The objective of the air permeability test is to determine site specific soil gas permeability and the extent of the subsurface that can be oxygenated using one air injection unit. Air will be injected into the 4-inch-diameter vent well using the blower unit, and pressure response will be measured at each MP with differential pressure gauges to determine the region influenced by the unit. Oxygen will also be monitored in the MPs to ascertain that oxygen levels in the soil increase as the result of air injection. One air permeability test lasting 4 to 8 hours will be performed.

## **4.0 INSTALLATION OF EXTENDED PILOT TEST SYSTEM**

Data collected during the pilot test will be analyzed to determine the rate of petroleum hydrocarbon biodegradation and the VW's zone of influence. This information will facilitate the development of a preliminary design of an expanded pilot test system for the extended test. These results will be summarized in a draft interim test results report and will be forwarded to the California Regional Water Quality Control Board, CALEPA, and Brooks and Vandenberg AFB for review and comment. After being reviewed and approved by the regulatory agencies and the Air Force, the design will be finalized, and additional vent wells and the air manifold system will be installed by the U.S. Department of Interior, Bureau of Land Reclamation, the primary site investigation contractor for Vandenberg AFB. ES will install and test the blower system following vent well installations.

Due to the explosive and hazardous nature of gasoline vapors, the extended pilot test system will use a low rate of soil gas extraction to draw oxygen-rich air into the soil and stimulate biological degradation. Extracted soil gas will initially be treated using the PURUS® vapor treatment system. Analysis of soil gas samples taken during the pilot test will help determine the PURUS® systems specifications. As hydrocarbon vapors are reduced to below 10,000 ppmv, the extracted soil gas will be

reinjected in a series of biofilter trenches located in an open field immediately southeast of the car wash facility. Using a slow rate of reinjection, these hydrocarbon vapors will be biodegraded by soil microorganisms. This method of vapor treatment has been demonstrated at Tyndall AFB and Eglin AFB. Air sampling above the biofilter trenches will be used to adjust flow rates and minimize vapor emissions to the atmosphere. Design of the biofilter trench system will begin following the initial bioventing tests.

## **5.0 EXCEPTIONS TO PROTOCOL PROCEDURES**

The procedures that will be used to measure the air permeability of the soil and in situ respiration rates are described in Sections 4 and 5 of the attached protocol document. The 1-year pilot test may involve additional VWs, the PURUS® system for concentrated vapor treatment, and biofilters for long-term vapor treatment. These exceptions to the protocol procedures will be further explored following review of the *in situ* respiration and soil permeability test results.

## **6.0 BASE SUPPORT REQUIREMENTS**

The following base support is needed prior to the arrival of the ES test team:

- Assistance in obtaining drilling and digging permits from Vandenberg AFB.
- Provision of any paperwork required to obtain gate passes and security badges for approximately three ES employees. Vehicle passes will be needed for two trucks.

During the initial testing, the following base support is needed:

- 24 hour per day use of a 110-volt, 15 amp, single-phase outlet at the BXSS for approximately 1 week.
- Twelve square feet of desk space and a telephone in a building located as close to the site as practical.
- The use of a facsimile machine for transmitting 15 to 20 pages of test results.
- Transportation from the site and acceptance of responsibility for drill cuttings from MP borings, including any drum sampling to determine hazardous waste status.

During the 1-year extended pilot test, base personnel will be required to perform the following activities:

- Provide a 230 volt, 100 amp, three-phase power supply for the blower system and PURUS® vapor treatment system. Assistance of a base electrician in completing power connections.
- Dispose of or recycle water and gasoline recovered by the PURUS® vapor treatment system.
- Check PURUS® vapor treatment system to ensure proper operation.

- Check the blower system once per week to ensure that it is operating and to record the air-extraction vacuum. ES will provide a brief training session on this procedure.
- If the blower stops working, notify Mr. Larry Dudus, ES Pasadena (818) 585-6063, Mr. Doug Downey, ES-Denver (303) 831-8100, or Mr. Sam Taffinder of the AFCEE (512) 536-4366.
- Arrange site access for an ES technician to conduct in situ respiration tests approximately 6 months and at 1 year after the initial pilot test.

## 7.0 PROJECT SCHEDULE

The following schedule is contingent upon timely approval of this pilot test work plan.

Event	Date
Draft Test Work Plan to AFCEE/ Vandenberg AFB	4 September 1992
Begin Initial Test	10 September 1992
Complete Initial Pilot Test	17 September 1992
Interim Results Report/Extended Test Design	30 October 1992
Regulatory Approval	17 November 1992
Construct Extended Test System	7 December 1992
Begin Extended Testing	21 December 1992
Respiration Test	April 1993
Final Respiration Test	December 1993

## 8.0 POINTS OF CONTACT

Mr. Layi Oyelowo  
30 SPW/ETI  
DNS: 275.8399  
Com: (805) 734-8232

Major Ross Miller  
AFCEE/ESR  
Brooks AFB, TX 78235-5000  
(512) 536-4329

Mr. Sam Taffinder  
AFCEE/ESR  
Brooks AFB, TX 78235-5000  
(512) 536-4366

Mr. Doug Downey  
Engineering-Science, Inc.  
1700 Broadway, Suite 900  
Denver, CO 80290  
(303) 831-8100  
Fax (303) 831-8208

Mr. Larry Dudus  
Engineering-Science  
199 S. Los Robles Avenue  
Pasadena, California 91101  
(818) 585-6063

## 9.0 REFERENCES

Site Assessment Report for Base Exchange Service Station, Site Characterization (Volume I). U.S. Bureau of Land Reclamation, March 1992.

Field Sampling Plan for AFCEE Bioventing. Engineering-Science, Inc., 1992.

Test Plan and Technical Protocol for a Field Treatability Test for Bioventing. Hinchee, R.E., Ong, S.K., Miller, R.N., Downey, D.C., Frandt, R., January 1992.