

LOAN DOCUMENT

PHOTOGRAPH THIS SHEET

0

DTIC ACCESSION NUMBER

LEVEL

INVENTORY

2 Parts

Bioventing Pilot Test Work Plan . . .

DOCUMENT IDENTIFICATION

Jun 94

DISTRIBUTION STATEMENT A
Approved for Public Release
Distribution Unlimited

DISTRIBUTION STATEMENT

DATE ACCESSIONED

DATE ACCESSIONED

DATE RETURNED

DATE RETURNED

REGISTERED OR CERTIFIED NUMBER

REGISTERED OR CERTIFIED NUMBER

ACCESSIONED BY	
NTIS	ORAS
DTIC	TRAC
UNANNOUNCED	
JUSTIFICATION	
BY	
DISTRIBUTION/	
AVAILABILITY CODES	
DISTRIBUTION	AVAILABILITY AND/OR SPECIAL
A-1	

DISTRIBUTION STAMP

20001130 026

DATE RECEIVED IN DTIC

PHOTOGRAPH THIS SHEET AND RETURN TO DTIC-FDAC

H
A
N
D
L
E

W
I
T
H

C
A
R
E

PART I

**BIOVENTING PILOT TEST WORK PLAN
ADDENDUM FOR SITE 6454,
FORMER FUEL TRANSFER FACILITY
VANDENBERG AFB, CALIFORNIA**

PART II

**DRAFT BIOVENTING PILOT TEST INTERIM
RESULTS REPORT FOR SITE 6454,
FORMER FUEL TRANSFER FACILITY
VANDENBERG AFB, CALIFORNIA**

Prepared For

**Air Force Center for Environmental Excellence
Brooks AFB, Texas**

and

Vandenberg AFB, California

ENGINEERING-SCIENCE, INC.
Design ■ Research ■ Planning
199 S. Los Robles Avenue
Pasadena, California 91101

June 1994

ENGINEERING-SCIENCE

AQM01-01-0366

DEFENSE TECHNICAL INFORMATION CENTER REQUEST FOR SCIENTIFIC AND TECHNICAL REPORTS

Title AFCEE Collection

1. Report Availability (Please check one box) <input checked="" type="checkbox"/> This report is available. Complete sections 2a - 2f. <input type="checkbox"/> This report is not available. Complete section 3.	2a. Number of Copies Forwarded	2b. Forwarding Date
	<u>Each</u>	<u>July/2000</u>

2c. Distribution Statement (Please check ONE box)

DoD Directive 5230.24, "Distribution Statements on Technical Documents," 18 Mar 87, contains seven distribution statements, as described briefly below. Technical documents MUST be assigned a distribution statement.

DISTRIBUTION STATEMENT A: Approved for public release. Distribution is unlimited.

DISTRIBUTION STATEMENT B: Distribution authorized to U.S. Government Agencies only.

DISTRIBUTION STATEMENT C: Distribution authorized to U.S. Government Agencies and their contractors.

DISTRIBUTION STATEMENT D: Distribution authorized to U.S. Department of Defense (DoD) and U.S DoD contractors only.

DISTRIBUTION STATEMENT E: Distribution authorized to U.S. Department of Defense (DoD) components only.

DISTRIBUTION STATEMENT F: Further dissemination only as directed by the controlling DoD office indicated below or by higher authority.

DISTRIBUTION STATEMENT X: Distribution authorized to U.S. Government agencies and private individuals or enterprises eligible to obtain export-controlled technical data in accordance with DoD Directive 5230.25, Withholding of Unclassified Technical Data from Public Disclosure, 6 Nov 84.

2d. Reason For the Above Distribution Statement (in accordance with DoD Directive 5230.24)

2e. Controlling Office <u>HQ AFCEE</u>	2f. Date of Distribution Statement Determination <u>15 Nov 2000</u>
---	--

3. This report is NOT forwarded for the following reasons. (Please check appropriate box)

It was previously forwarded to DTIC on (date) and the AD number is

It will be published at a later date. Enter approximate date if known.

In accordance with the provisions of DoD Directive 3200.12, the requested document is not supplied because:
.....
.....

Print or Type Name <u>Laura Peña</u>	Signature <u>Laura Peña</u>
Telephone <u>210-536-1431</u>	(For DTIC Use Only) AQ Number <u>M01-01-0366</u>

TABLE OF CONTENTS

PART I

BIOVENTING PILOT TEST WORK PLAN ADDENDUM FOR SITE 6454, FORMER FUEL TRANSFER FACILITY VANDENBERG AFB, CALIFORNIA

1.0	INTRODUCTION	I-1
2.0	SITE DESCRIPTION	I-1
2.1	Site Location and History	I-1
2.2	Site Geology	I-1
2.3	Site Contamination	I-3
3.0	SITE SPECIFIC ACTIVITIES.....	I-3
3.1	Site 6454 Pilot Test Layout and Construction.....	I-3
3.2	Vent Well and Monitoring Points.....	I-3
3.3	Handling of Drill Cuttings	I-7
3.4	Soil and Soil Gas Sampling	I-7
3.5	Blower System	I-7
3.6	<i>In-situ</i> Respiration Test and Air Permeability Tests.....	I-7
3.7	Potential Air Emissions.....	I-7
3.8	Extended Pilot Test Bioventing System	I-7
4.0	EXCEPTIONS TO PROTOCOL PROCEDURES	I-8
5.0	BASE SUPPORT REQUIREMENTS.....	I-8
6.0	PROJECT SCHEDULE.....	I-9
7.0	POINTS OF CONTACT	I-9
8.0	REFERENCES	I-10

LIST OF FIGURES

Figure 1	Site Location Map and Proposed Vent Well/Vapor Monitoring Point Locations, Site 6454	I-2
Figure 2	Proposed Air Injection Vent Well Construction Details, Site 6454 .	I-5
Figure 3	Proposed Monitoring Point Construction Details, Site 6454	I-6

LIST OF TABLES

Table 1	Summary of Bureau of Reclamation Analytical Data, Site 6454	I-4
---------	--	-----

PART I

BIOVENTING PILOT TEST WORK PLAN ADDENDUM SITE 6454, FORMER FUEL TRANSFER FACILITY VANDENBERG AFB, CALIFORNIA

1.0 INTRODUCTION

This addendum modifies the existing "Bioventing Pilot Test Work Plan for Base Exchange Service Station Underground Storage Tank Area, Vandenberg AFB, California", September 1992. This addendum provides site specific information for the second bioventing pilot test to be conducted at Vandenberg AFB.

2.0 SITE DESCRIPTION

2.1 Site Location and History

Site 6454 is located between New Mexico Avenue and a railroad spur, approximately 300 feet southwest of the intersection of 13th Street and New Mexico. Four underground storage tanks and associated piping were located between the railroad spur and New Mexico Avenue. The facility was reported to be a transfer point for both diesel and JP-4. In 1986, a search was made for the tanks but they were not found; Therefore, the tanks were assumed to be removed prior to that time. Currently, the site is an unpaved open field.

In 1992, the Bureau of Reclamation drilled and sampled 14 soil borings in an attempt to characterize site contamination. Soil contamination, as characterized by the Bureau, is believed to be from both diesel and JP-4. The site layout and the location of the 14 soil borings are shown in Figure 1. A summary of the site geology and site contamination is presented in subsection 2.2 and 2.3, respectively.

2.2 Site Geology

Site 6454 is located on the Burton Mesa, a relatively flat area consisting of alluvial sediments. The sediments of the Burton Mesa lie unconformably on the Monterey Shale. Silty sand and clayey sand appear to be the dominant soil type at the site. In most of the borings, silty sand was encountered from the surface to about 5 feet below ground surface (bgs). From 5 feet to approximately 70 feet bgs silty sand and clayey sand was encountered along with numerous and apparently isolated lenses of clay and silt. These lenses, occasionally up to 10 feet in thickness, rarely correlated between borings.

Shale was encountered at approximately 73 feet bgs in the deeper borings. Groundwater was not encountered at the site.

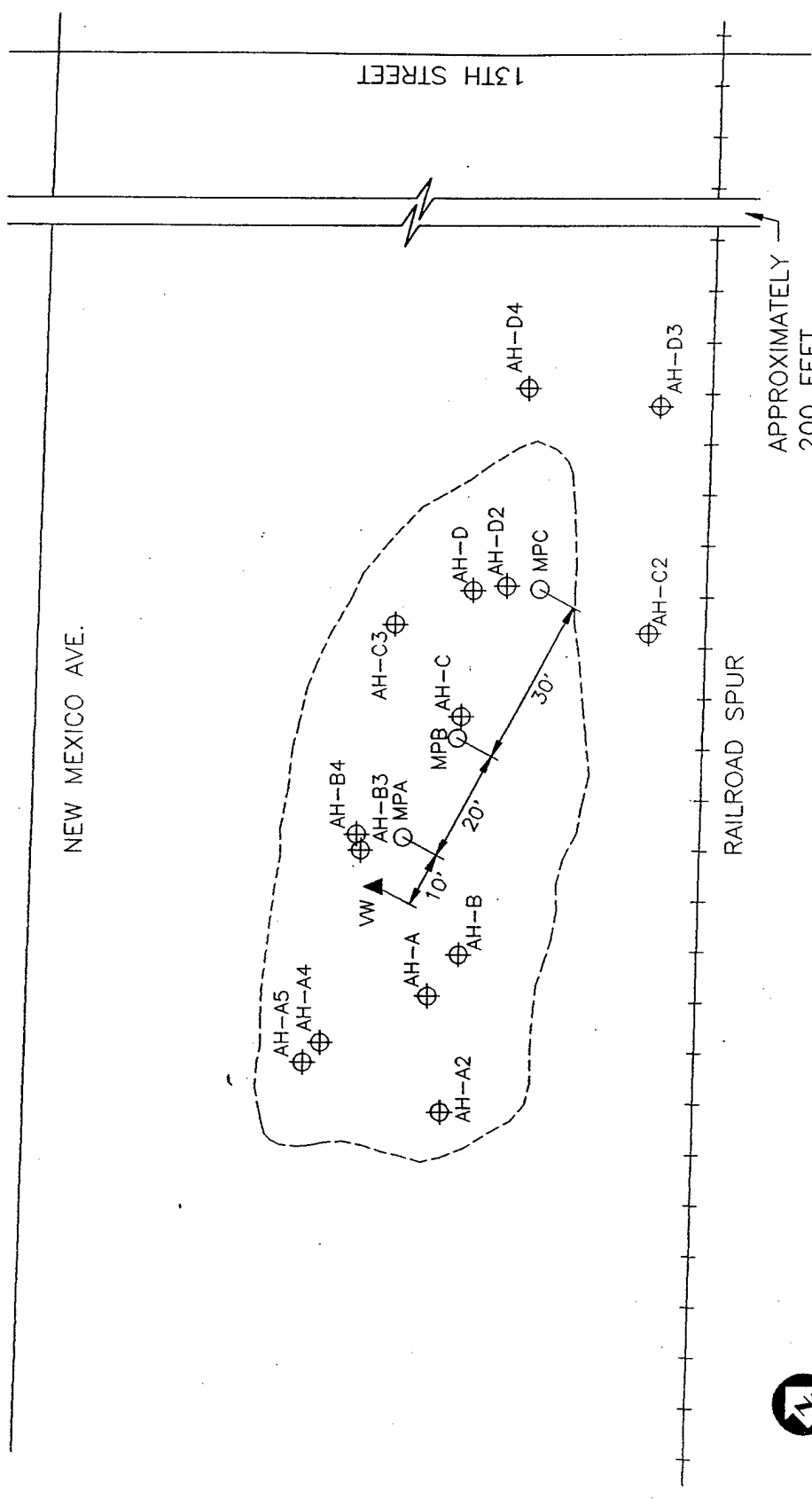

SOURCE: BUREAU OF RECLAMATION SITE SKETCH

LEGEND

- APPROXIMATE EXTENT OF TPH CONTAMINATION ABOVE 10 mg/kg
- ⊕ EXISTING BORING
- ▲ PROPOSED VENT WELL
- PROPOSED MONITORING POINT

FIGURE 1
SITE LOCATION MAP AND PROPOSED VENT WELL/VAPOR MONITORING POINT LOCATIONS - SITE 6454

VANDENBERG AFB, CALIFORNIA
 ENGINEERING-SCIENCE, INC.
 Pasadena, California



2.3 Site Contamination

Soil samples collected during the Bureau of Reclamation investigation were analyzed for total petroleum hydrocarbons (TPH) in the diesel range by EPA method 8015 modified for diesel. Selected samples were analyzed for benzene, toluene, ethylbenzene, and xylenes by EPA method 8020. Table 1 summarizes the analytical results for samples with greater than 100 mg/kg TPH as diesel.

The highest concentrations of diesel contamination were found in boring AH-B and AH-B3 - AH-B4. Boring AH-B4 is an extension of AH-B3 and is located adjacent to it. These two borings will be referred to as AH-B3-B4. Analytical results from a sample at 49.5 feet bgs in AH-B and 20 feet bgs in AH-B3-B4 were 8,800 and 9,500 mg/kg TPH as diesel, respectively. TPH-diesel concentrations exceeding 100 mg/kg were detected in soil samples collected as deep as 64.5 feet bgs in AH-B and 71.1 feet bgs in AH-B3-B4. In most of the remaining borings, contamination was detected at or near the surface and extended to approximately 30 feet bgs. Most of the samples had analytical results below 100 mg/kg TPH as diesel and are not included in Table 1. It has been learned from the Bureau that site contamination is believed to be from both diesel and JP-4.

3.0 SITE SPECIFIC ACTIVITIES

Site specific activities include: (1) siting and construction of a central air injection well (VW) and three vapor monitoring points (MPs); (2) an air permeability test; (3) an *in-situ* respiration test; and (4) the implementation of an extended (one-year) pilot test.

3.1 Site 6454 Pilot Test Layout and Construction

A general description of criteria for siting a central VW and vapor MPs are included in the protocol document (Hinchee et al., 1992). Figure 1 illustrates the proposed locations of the central VW and MPs within Site 6454. The final locations of these wells may vary slightly from the proposed locations if significant fuel contamination is not observed in the boring for the central VW. Soils in this area are expected to be oxygen depleted (<2%) due to high hydrocarbon levels, and increased biological activity should be stimulated by oxygen-rich air injection into the subsurface during pilot test operations.

The potential radius of venting influence around the central VW is expected to be 40 to 60 feet. Three vapor MPs (MPA, MPB, and MPC) will be located within a 60 foot radial distance of the central VW. A background MP will be installed approximately 300 feet south west of the site. Background levels of oxygen and carbon dioxide levels will be monitored to determine if natural carbon sources are contributing to oxygen uptake during the *in-situ* respiration tests. Additional details on *in-situ* respiration test procedures are found in Section 5.7 of the protocol document (Hinchee et al., 1992).

3.2 Vent Well and Monitoring Points

The VW and MPs will be constructed as shown in Figures 2 and 3, respectively and as described in the Bioventing Protocol Document.

Table 1

Summary of Bureau of Reclamation Analytical Data*
 Site 6454, Vandenberg AFB, California

Boring ID	Depth (feet bgs)	TPH as Diesel mg/kg	Benzene $\mu\text{g}/\text{kg}$	Toluene $\mu\text{g}/\text{kg}$	Ethylbenzene $\mu\text{g}/\text{kg}$	Xylenes $\mu\text{g}/\text{kg}$
AH-A	4.6	1,300	.06	.43	.17	1.1
AH-B	17.5	1,400	NA	NA	NA	NA
AH-B	22.5	150	NA	NA	NA	NA
AH-B	29.5	6,000	NA	NA	NA	NA
AH-B	34.5	7,400	NA	NA	NA	NA
AH-B	39.5	2,900	NA	NA	NA	NA
AH-B	44.3	800	NA	NA	NA	NA
AH-B	49.5	8,800	0.3	4.8	3.1	15.0
AH-B	54.5	600	NA	NA	NA	NA
AH-B	59.5	4,500	NA	NA	NA	NA
AH-B	64.5	150	NA	NA	NA	NA
AH-C	19.5	700	NA	NA	NA	NA
AH-D2	4.8	6,200	NA	NA	NA	NA
AH-B3	14.75	1,300	38	434	441	1,700
AH-B3	19.75	9,500	NA	NA	NA	NA
AH-B3	39.75	2,000	NA	NA	NA	NA
AH-B3	44.75	3,500	NA	NA	NA	NA
AH-B3	49.75	4,100	NA	NA	NA	NA
AH-B4	59.8	1,100	620	7,300	12,000	50,000
AH-B4	64.8	5,600	NA	NA	NA	NA
AH-B4	69.8	6,900	NA	NA	NA	NA
AH-B4	71.1	6,000	NA	NA	NA	NA
AH-A5	39.75	210	NA	NA	NA	NA
AH-A5	49.75	1,000	NA	NA	NA	NA

* For analytical results greater than 100 mg/kg TPH as diesel.
 NA = Not Analyzed.

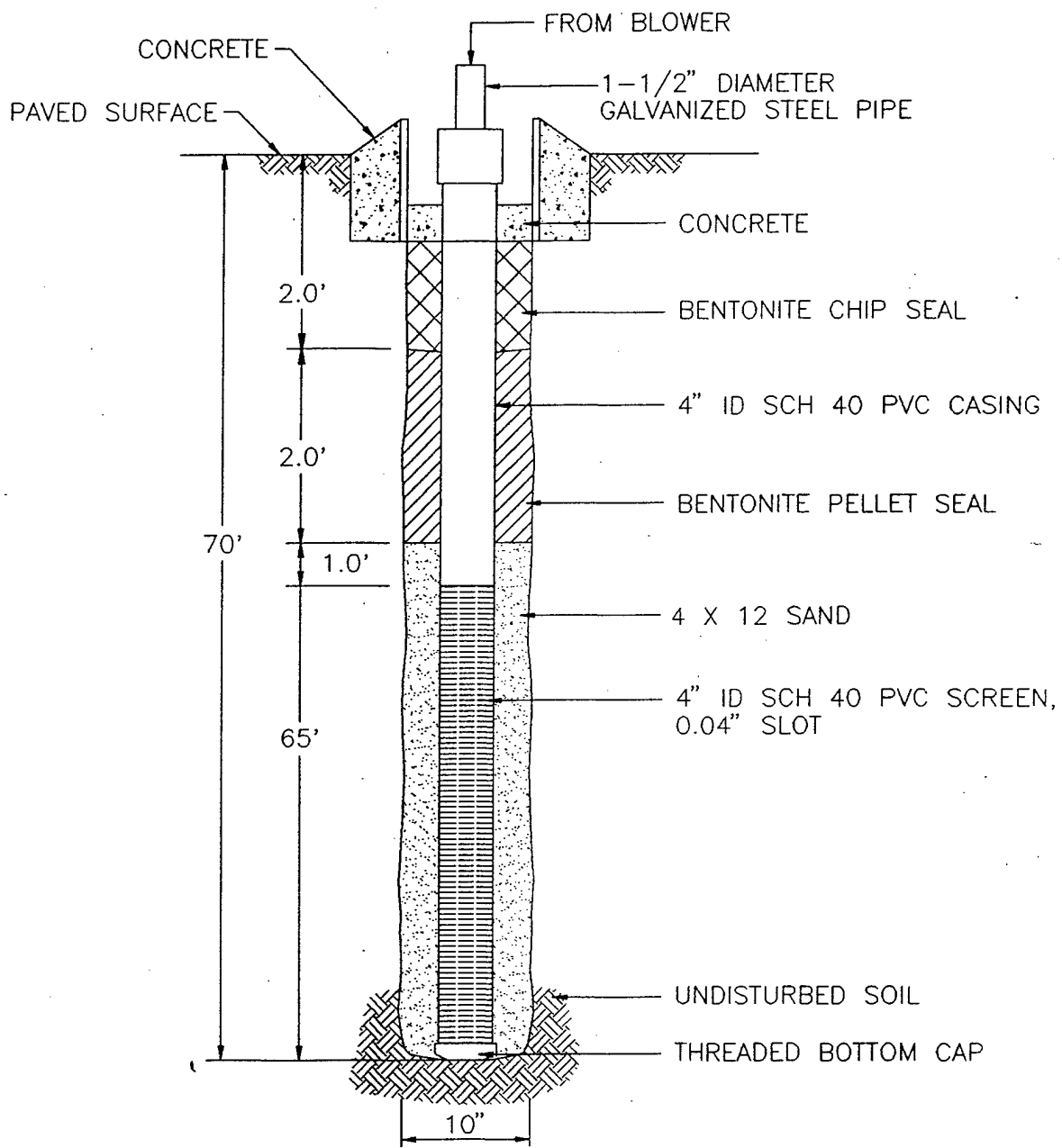

NOT TO SCALE

FIGURE 2
 PROPOSED
 AIR INJECTION VENT WELL
 CONSTRUCTION DETAILS
 SITE 6454

VANDENBERG AFB, CALIFORNIA

ENGINEERING-SCIENCE, INC.
 Pasadena, California



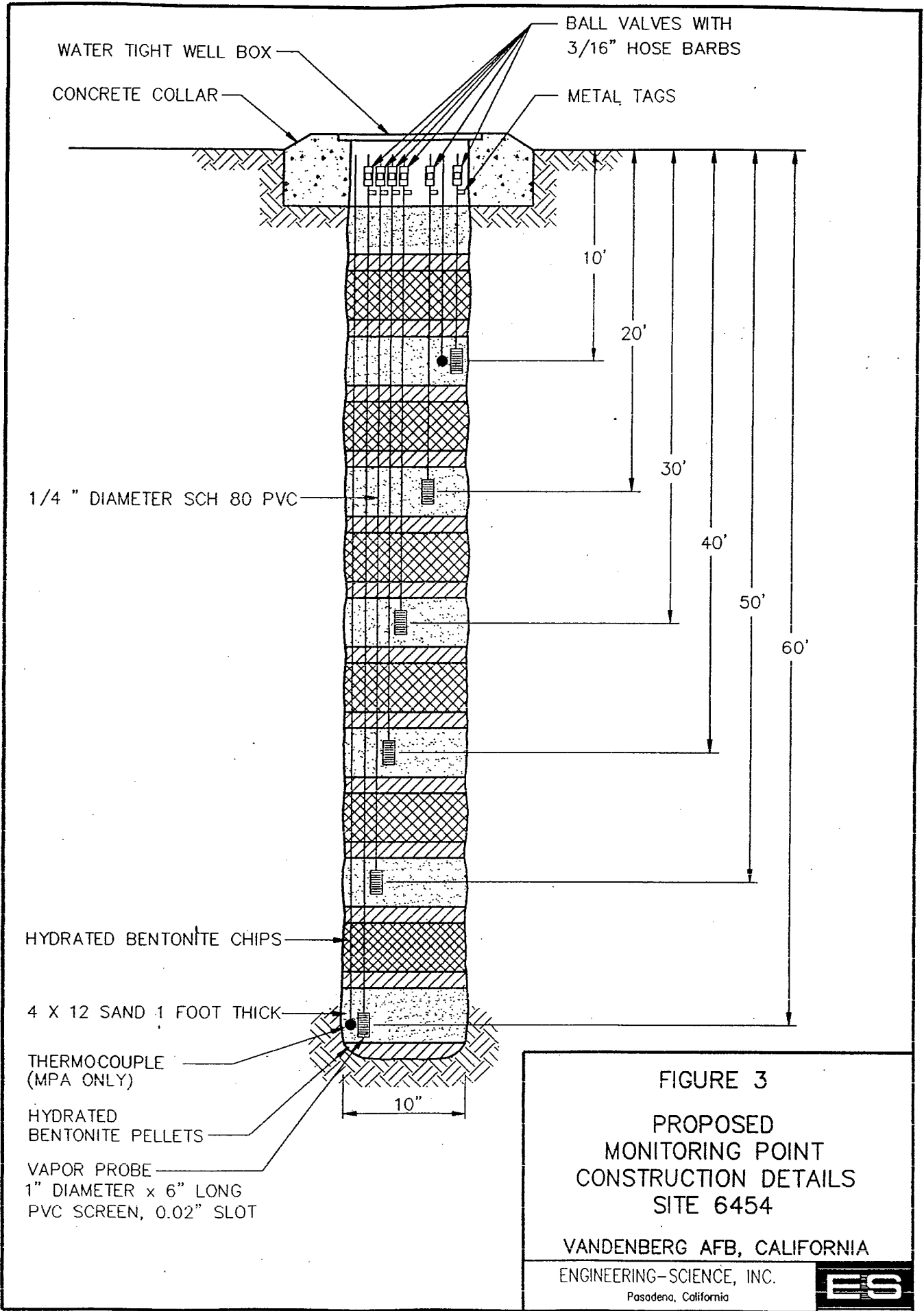

WATER TIGHT WELL BOX

CONCRETE COLLAR

BALL VALVES WITH
3/16" HOSE BARBS

METAL TAGS

1/4 " DIAMETER SCH 80 PVC

HYDRATED BENTONITE CHIPS

4 X 12 SAND 1 FOOT THICK

THERMOCOUPLE
(MPA ONLY)

HYDRATED
BENTONITE PELLETS

VAPOR PROBE
1" DIAMETER x 6" LONG
PVC SCREEN, 0.02" SLOT

FIGURE 3
PROPOSED
MONITORING POINT
CONSTRUCTION DETAILS
SITE 6454

VANDENBERG AFB, CALIFORNIA

ENGINEERING-SCIENCE, INC.
Pasadena, California



3.3 Handling of Drill Cuttings

All cuttings will be collected in U.S. Department of Transportation (DOT) approved containers. Engineering-Science will coordinate with the Bureau of Reclamation for disposal of the cuttings.

3.4 Soil and Soil Gas Sampling

Soil and soil gas sampling procedures as described in the September 1992 Bioventing Work Plan will be followed except that soil samples will be shipped to Pace Analytical Laboratories (formerly ES Laboratory) in Novato, California.

3.5 Blower System

A 1-horsepower regenerative blower capable of injecting up to 30 standard cubic feet per minute (scfm) at 40-inches of water will be used to conduct the initial air permeability test. A schematic of a typical air injection system used for pilot testing is shown in Figure 3.4 of the September 1992 Bioventing Pilot Test Work Plan for the Base Exchange Service Station. The maximum power requirement anticipated for this pilot test is a 115-volt, single-phase, 30-amp service. Additional details on power supply requirements are described in Section 5.0, Base Support Requirements.

3.6 *In-situ* Respiration Test and Air Permeability Tests

In-situ respiration and air permeability tests as described in sections 3.5 and 3.6 of the September 1992 Bioventing Pilot Test Work Plan will be conducted at Site 6454.

3.7 Potential Air Emissions

Soil gas will not be extracted from the site during either the initial or extended pilot test. The proposed bioventing system will use a low rate (approximately 30 scfm) of air injection to provide oxygen for enhanced biodegradation. Because these soils are contaminated with low-volatility diesel oil and JP-4, the potential for volatile emissions is very low. Because horizontal permeability is generally greater than vertical permeability, the injected air will tend to move outward rather than upward. Any accumulated fuel vapors will be biodegraded as they move slowly outward from the center of the spill into clean, oxygen-rich soil.

If some upward movement of injected air does occur, it will be highest during the first day of air injection when the initial soil gas volume is displaced. ES will carefully monitor air at the VW and MPs and in the breathing zone during the first day of testing. A photoionization detector (PID) will be used to detect any emissions exceeding ambient conditions. The PID will be calibrated to detect BTEX compounds at the 1 ppmv level. This level of detection is consistent with the most conservative OSHA standards. Any sustained BTEX reading in excess of 1 ppmv will require an immediate reduction in air injection rates.

3.8 Extended Pilot Test Bioventing System

A bioventing system for the extended (1-year) pilot testing will be installed at the test site following the initial pilot test. An outside contractor will be used to provide a power pole with a 115-volt, single-phase, 30-amp breaker box, one 115-volt line which

will be connected to the blower, and two 115-volt receptacles. A 1-horsepower regenerative blower will be housed over the vent well in a small, pre-fabricated shed to provide protection from the weather.

The system will be operated for 1 year. After 6 months ES personnel will conduct an *in-situ* respiration test to monitor the long-term performance of this bioventing system. Weekly system checks will be performed by Vandenberg AFB personnel. If required, any major maintenance of the blower unit will be performed by ES personnel. Detailed blower system information and a maintenance schedule will be included in the operation and maintenance (O&M) manual provided to the base. More detailed information regarding the extended pilot test procedures can be found in the protocol document (Hinchee et al., 1992).

4.0 EXCEPTIONS TO PROTOCOL PROCEDURES

The procedures that will be used to construct wells, measure the air permeability of the soil and *in-situ* respiration rates are described in Sections 4 and 5 of the protocol document (Hinchee et al., 1992). No exceptions to the protocol document procedures are anticipated.

5.0 BASE SUPPORT REQUIREMENTS

The following base support is needed prior to arrival of the drilling subcontractor and the ES pilot test team:

- Provisions of any paperwork required to obtain gate passes and security badges for approximately three ES employees, three drillers, and an electrician (if a base electrician is not available). Vehicle passes will be needed for one truck and trailer, and a drill rig. Prior to arrival on base, ES will provide written social security numbers of the field team and drillers.

During initial testing, the following base support is needed:

- Twelve square feet of desk space and a telephone in a building located as close to the site as practical.
- The use of a facsimile machine for transmitting 15 to 20 pages of test results.

During the 1-year extended pilot tests, base personnel will be required to perform the following activities:

- Check the blower system once per week to ensure that it is operating and to record the air injection pressure and temperature. ES will provide a brief training session for this procedure and a maintenance procedures manual with data collection sheets.
- If the blower stops working, notify: Mr. Larry Dudus of ES San Diego at (619) 453-9650, Mr. Chris Pluhar of ES Pasadena at (818) 585-6324 or Mr. Sam Taffinder of AFCEE at (210) 536-4366.
- Arrange site access for an ES technician to conduct *in-situ* respiration tests approximately 6 months and 1 year after the initial pilot test.

To expedite the schedule, Engineering-Science will coordinate with the Bureau of Reclamation to obtain digging permits and to dispose of drill cuttings. Engineering-Science will also use a local contractor to install a 115-volt, 30-amp, single-phase breaker box with one 115-volt line which will be connected to the blower, and two 115-volt receptacles near the VW.

6.0 PROJECT SCHEDULE

The following schedule is contingent upon timely approval of this pilot test work plan.

<u>Event</u>	<u>Date</u>
Draft Test Work Plan Addendum to AFCEE/ Vandenberg AFB	12 November 1993
Approval to Proceed	6 December 1993
Begin Initial Pilot Test	28 February 1994
Interim Results Report	June 1994
Second Respiration Test	September 1994
Final Respiration Test and Soil Sampling	March 1995

7.0 POINTS OF CONTACT

Lt. Col. George Lane
Director, Environmental Restoration
730th CES/CEVR
806 13th Street, Room 115
Vandenberg AFB, California 93437-5242
(805) 734-8232 Ext. 50635

Major Lt. Col. Ross Miller/Mr. Sam Taffinder
AFCEE/EST
800 Arnold Drive
Brooks AFB, TX 78235-5103
(210) 536-4366

Mr. Larry Dudus
Engineering-Science, Inc.
9404 Genesee Ave., Suite 140
La Jolla, CA 92307
(619) 453-9650
Fax (619) 453-9652

Mr. Doug Downey
Engineering-Science, Inc.
1700 Broadway, Suite 900
Denver, CO 80290
(303) 831-8100
Fax (303) 831-8208

8.0 REFERENCES

Engineering-Science, Inc. 1992. *Bioventing Pilot Test Work Plan for the BX Service Station, Vandenberg AFB, California*. Pasadena, California.

Engineering-Science, Inc. 1992. *Field Sampling Plan for AFCEE Bioventing*. Denver, Colorado.

Hinchee, R. E., S. K. Ong, R. N. Miller, D. C. Downey, and R. Frandt. 1992. *Test Plan and Technical Protocol for a Field Treatability Test for Bioventing*. January.

Bureau of Reclamation 1993. *Site Characterization Analytical Results*.

PART II
BIOVENTING PILOT TEST INTERIM RESULTS REPORT
SITE 6454, FORMER FUEL TRANSFER FACILITY
VANDENBERG AFB, CALIFORNIA

TABLE OF CONTENTS

PART II

BIOVENTING PILOT TEST INTERIM RESULTS REPORT

SITE 6454, FORMER FUEL TRANSFER FACILITY

VANDENBERG AFB, CALIFORNIA

1.0	INTRODUCTION	II-1
2.0	SITE 6454	II-1
2.1	Pilot Test Design and Construction	II-1
2.1.1	Air Injection Vent Well	II-1
2.1.2	Monitoring Point	II-5
2.1.3	Blower Unit	II-5
2.2	Soil and Soil Gas Sampling Results	II-5
2.2.1	Soil Sampling Results	II-5
2.2.2	Soil Gas Sampling Results	II-8
2.3	Pilot Test Results	II-8
2.3.1	Exceptions to Test Protocol Procedures	II-8
2.3.2	Initial Soil Gas Chemistry	II-10
2.3.3	<i>In Situ</i> Respiration Rates	II-11
2.3.4	Air Permeability Test	II-12
2.3.5	Oxygen Influence	II-12
2.3.6	Potential Air Emissions	II-20
2.4	Recommendations	II-20
3.0	REFERENCES	II-21

LIST OF FIGURES

Figure 2.1	Record Drawing Vent Well/Vapor Monitoring Point Locations, Site 6454	II-2
Figure 2.2	Geologic Cross-Section A-A', Site 6454 Former Fuel Transfer Facility.....	II-3
Figure 2.3	Record Drawing Air Injection Vent Well Construction Details.....	II-4
Figure 2.4	Record Drawing Monitoring Point Construction Details	II-6
Figure 2.5	Record Drawing Blower System for Air Injection, Site 6454.....	II-7
Figure 2.6	Respiration Test, VA2-MPA-10.....	II-13
Figure 2.7	Respiration Test, VA2-MPA-40.....	II-14
Figure 2.8	Respiration Test, VA2-MPB-20	II-15
Figure 2.9	Respiration Test, VA2-MPB-50	II-16
Figure 2.10	Respiration Test, VA2-MPC-30.....	II-17
Figure 2.11	Respiration Test, VA2-MPC-60.....	II-18

LIST OF TABLES

Table 2.1	Soil and Soil Gas Laboratory Analytical Results, Site 6454.....	II-9
Table 2.2	Laboratory Analytical Results for EPA Method 8010, Site 6454..	II-10
Table 2.3	Initial Soil Gas Chemistry, Site 6454	II-11
Table 2.4	Oxygen Utilization Rates, Site 6454	II-12
Table 2.5	Pressure Response During Air Permeability Test, Site 6454.....	II-19
Table 2.6	Influence of Air Injection Vent Well on Monitoring Point Oxygen Levels.....	II-21

LIST OF APPENDICES

APPENDIX A Operation and Maintenance Manual

APPENDIX B Geologic Boring Logs and Chain of Custody Forms

PART II

BIOVENTING PILOT TEST INTERIM RESULTS REPORT SITE 6454, FORMER FUEL TRANSFER FACILITY VANDENBERG AFB, CALIFORNIA

1.0 INTRODUCTION

The purpose of Part II of this report is to describe the results of the initial pilot test at Site 6454 and to make specific recommendations for extended testing, which will determine the long term impact of bioventing on site contaminants. An initial bioventing pilot test was completed at Site 6454 during March 1994. Descriptions of the history, geology, and contaminants at the site are contained in Part I, the Bioventing Pilot Test Work Plan Addendum.

2.0 SITE 6454, FORMER FUEL TRANSFER FACILITY

2.1 Pilot Test Design and Construction

Installation of one air injection vent well (VW) and three vapor monitoring points (MPs) at Site 6454 former fuel transfer facility site (designated VA2) was completed on February 26, 1994. Drilling services were provided by Tonto Environmental Drilling of Fontana, California. Well installation, soil and soil gas sampling was completed by Mr. Chris Pluhar and Mr. Thomas Blaney, geologists with Engineering-Science, Inc. The following sections describe the final design and installation of the bioventing pilot test at this site.

One VW (VA2-VW), three MPs (VA2-MPA, VA2-MPB, VA2-MPC), and a blower unit were installed at the site. Figures 2.1 and 2.2, respectively, depict the location of, and a geologic cross-section for, the VW and MPs.

2.1.1 Air Injection Vent Well

The air injection VW was installed following procedures described in the Air Force Center for Environmental Excellence (AFCEE) bioventing protocol document (Hinchee et al., 1992). Figure 2.3 shows construction details for VA2-VW.

The VW was installed in hydrocarbon contaminated soil through the former tank bed where four underground storage tanks had been located. The VW was constructed using 4-inch inside diameter (ID), Schedule 40 polyvinyl chloride (PVC) casing from ground surface to four (4) feet below ground surface (bgs), with 70 feet of 0.04-inch slotted PVC screen installed from 4 to 74 feet bgs and a PVC end cap from 74 to 74.5 feet bgs. The annular space between the well casing and the borehole sidewall was filled with 4 X 12 sand from 3 (one foot above the well screen) to 75 feet bgs. Approximately three (3) feet of bentonite chips were placed above the sand and hydrated in place. The top of the well was completed with a flush-mounted metal well vault set in a concrete pad approximately 2.5 feet in diameter. The well casing was

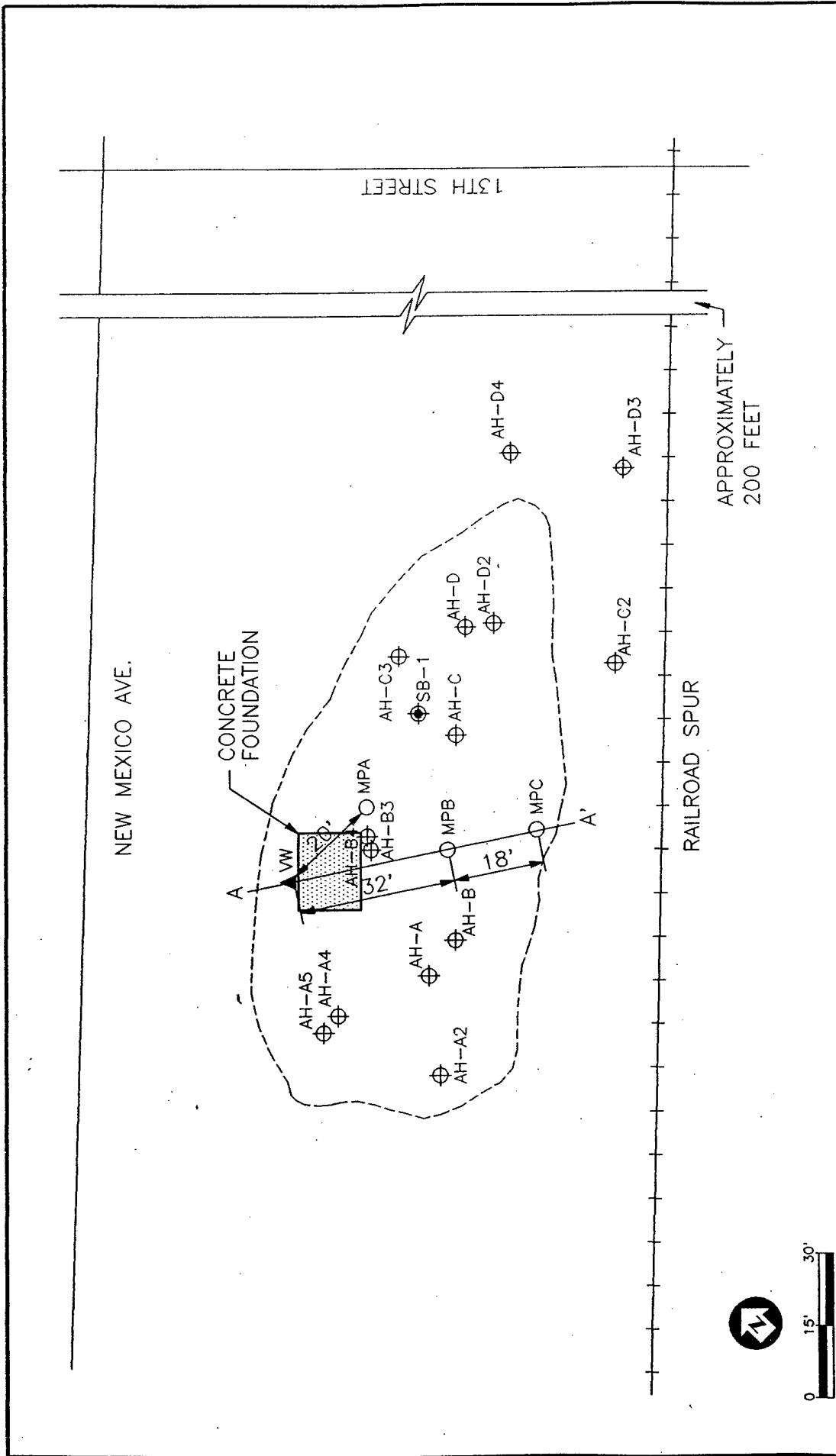

FIGURE 2.1
RECORD DRAWING
VENT WELL/VAPOR MONITORING
POINT LOCATIONS - SITE 6454
FORMER FUEL TRANSFER FACILITY
VANDENBERG AFB, CALIFORNIA

ENGINEERING-SCIENCE, INC.
 Pasadena, California



SOURCE: BUREAU OF RECLAMATION SITE SKETCH

LEGEND

- APPROXIMATE EXTENT OF TPH CONTAMINATION ABOVE 10 mg/kg
- ▲ VENT WELL
- MONITORING POINT
- ⊕ APPROXIMATE LOCATION OF EXISTING BORING
- ⊕ NEW SOIL BORING

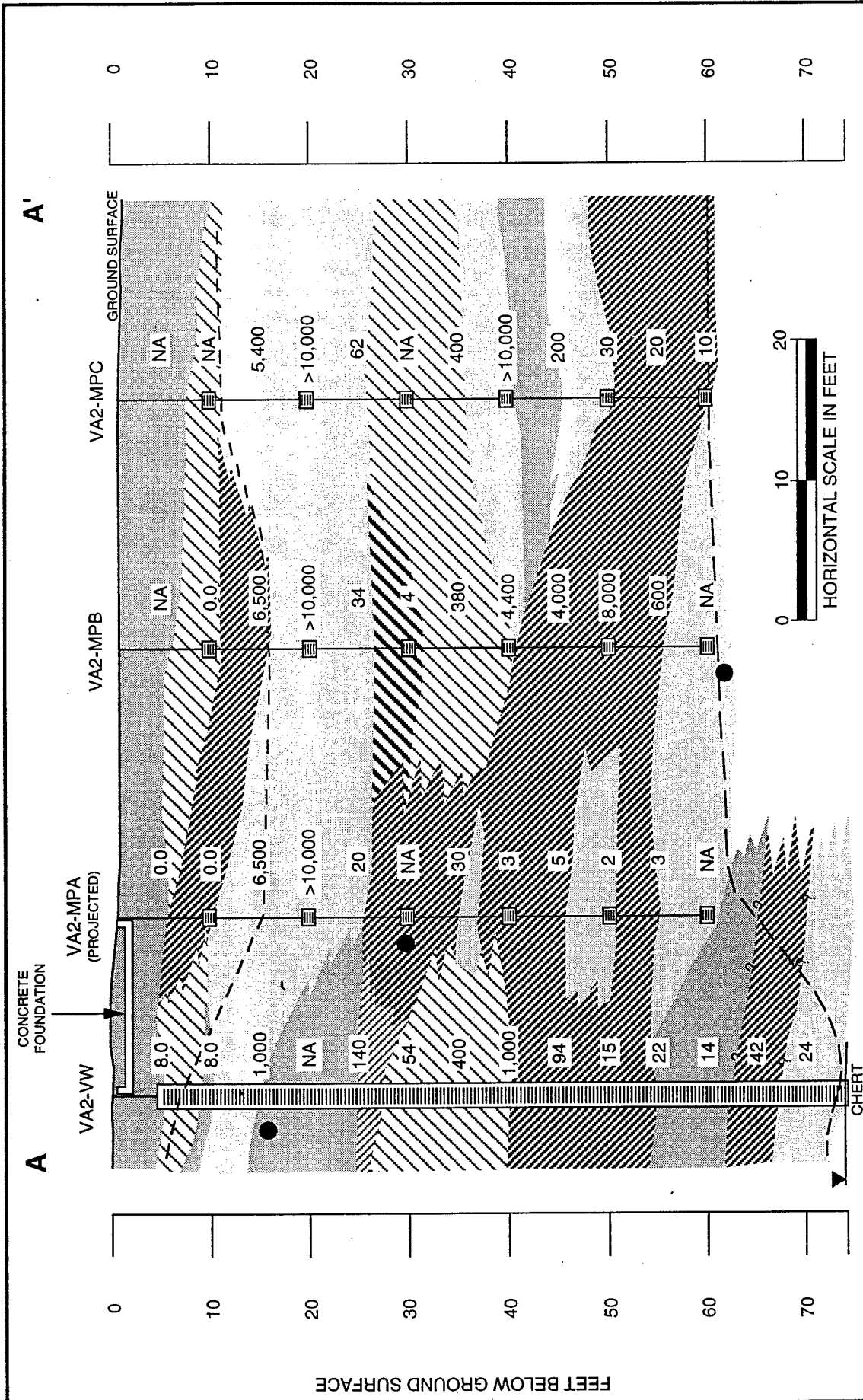

LEGEND

	SAND		SANDY CLAY AND CLAY		WV SCREENED INTERVAL
	SILTY SAND		FATTY CLAY	8.0	TVH READINGS IN PPM
	CLAYEY SAND		SOIL SAMPLE	---	APPROXIMATE EXTENT OF SOIL CONTAMINATION
	CLAY		MP SCREENED INTERVAL	NA	NOT ANALYZED

FIGURE 2.2

GEOLOGIC CROSS-SECTION A-A'

SITE 6454 FORMER FUEL TRANSFER FACILITY

VANDENBERG AFB, CALIFORNIA

ENGINEERING-SCIENCE, INC.
Pasadena, California

ES

(MAC BLANEY DISK 1) VARB BIOVENTING REPT FIG 2.2

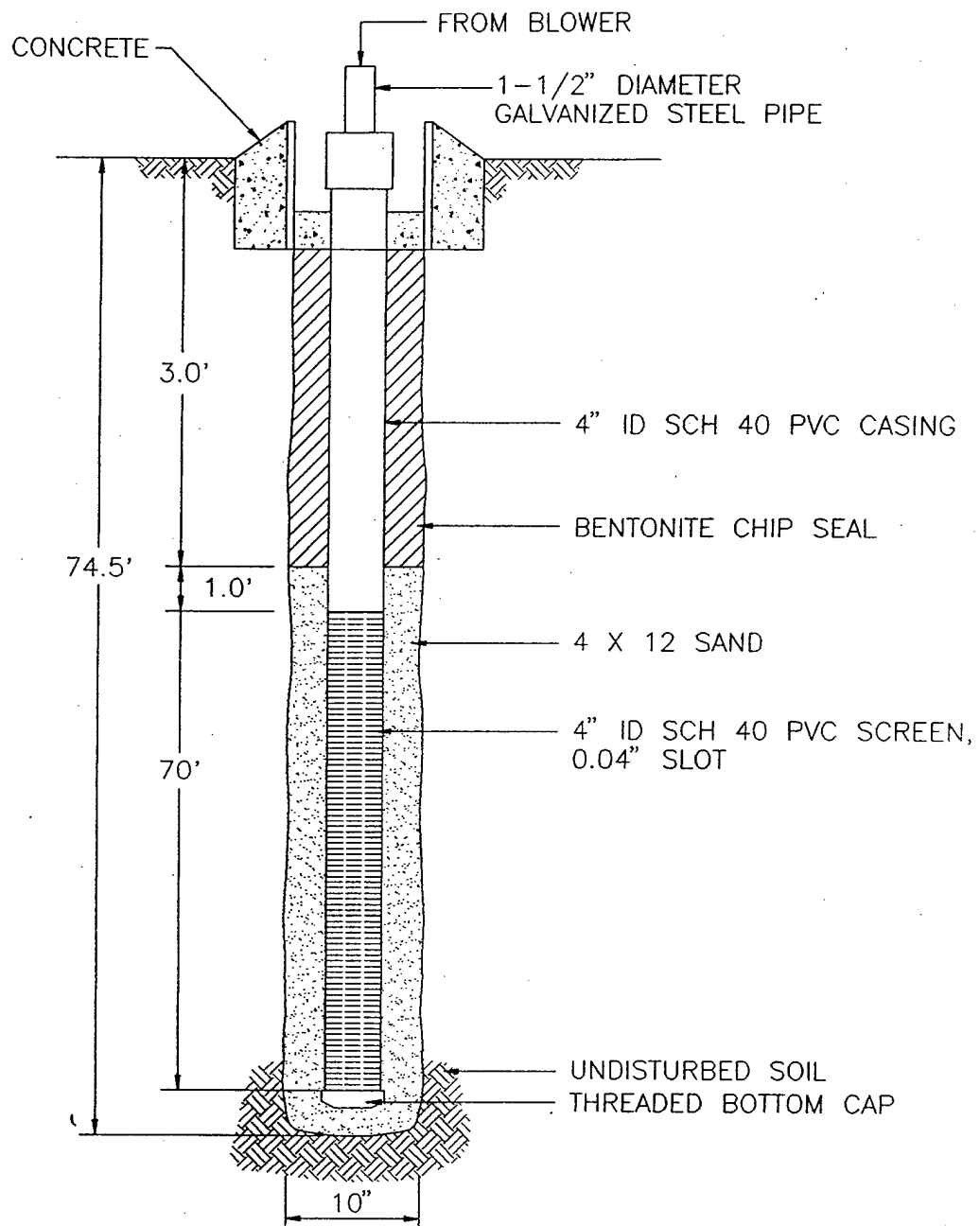

NOT TO SCALE

FIGURE 2.3

RECORD DRAWING
 AIR INJECTION VENT WELL
 CONSTRUCTION DETAILS
 SITE 6454

VANDENBERG AFB, CALIFORNIA

ENGINEERING-SCIENCE, INC.
 Pasadena, California



finished with a PVC 4-inch to 2-inch reducer. The reducer was connected to 2-inch Schedule 40 PVC pipe which in turn connected to the galvanized piping from the blower via a 2-inch PVC to 1.5-inch pipe threaded reducer. The blower and blower shed sit directly on top of the well vault.

2.1.2 Monitoring Points

The MP screens were installed at 10, 20, 30, 40, 50, and 60 feet bgs. The MPs were constructed as shown in Figures 2.2 and 2.4. The MP monitoring intervals were constructed using a 6-inch section of 1-inch diameter 0.02-inch slotted PVC well screen, and 0.25-inch diameter Schedule 80 PVC riser pipe extending to ground surface. At the top of each riser, a ball valve and a 3/16-inch hose barb were installed. The top of each MP was completed with a flush-mounted metal well vault set in a concrete base. Thermocouples were installed at the 10 and 60 foot depths in MPA, the nearest monitoring point to the VW.

2.1.3 Blower Unit

A 1-horsepower Gast[®] regenerative blower was used for both the initial air permeability test and the extended pilot test. For the extended pilot test, the blower was installed in a small weatherproof shed on site. The fixed unit is powered by a 208-volt, single-phase, 60-amp power line, approximately eighteen (18) inches bgs, running from the blower shed to an adjacent power box located approximately 120 feet east of the site. The configuration, instrumentation, and specifications for this blower system are shown in Figure 2.5. The blower is currently injecting air at a flow rate of approximately 68 cubic feet per minute (cfm) for the extended pilot test. After blower installation and start-up, ES engineers provided an operation and maintenance (O&M) manual, including maintenance instructions, equipment specifications, and monitoring forms, to base personnel. A copy of the O&M manual is provided in Appendix A.

2.2 Soil and Soil Gas Sampling Results

2.2.1 Soil Sampling Results

Soils at the site consisted mostly of sand, sandy clay, and clayey sand. Chert was encountered at 75 feet bgs in the VW and groundwater was encountered just above the chert layer.

During drilling, evidence of contamination was found to be areally extensive and relatively homogeneous throughout the four (4) drilling locations. This is corroborated in studies performed by the Bureau of Reclamation. Evidence of contamination (strong hydrocarbon odor) was found in the VW from approximately 5 to 74 feet bgs, in MPA and MPB from approximately 15 to 62 feet bgs, and from approximately 10 to 62 feet bgs in MPC. Field measurements, using a GasTech[®] Tracetector[®] hydrocarbon meter, indicated volatile hydrocarbons in the VW ranging from 8 to 1,000 parts per million (ppm). In MPA, MPB, and MPC, volatile hydrocarbons measurements ranged from 0 to >10,000 ppm.

More geologic information regarding the site can be found in the cross-section (Figure 2.2) and the geologic boring logs found in Appendix B.

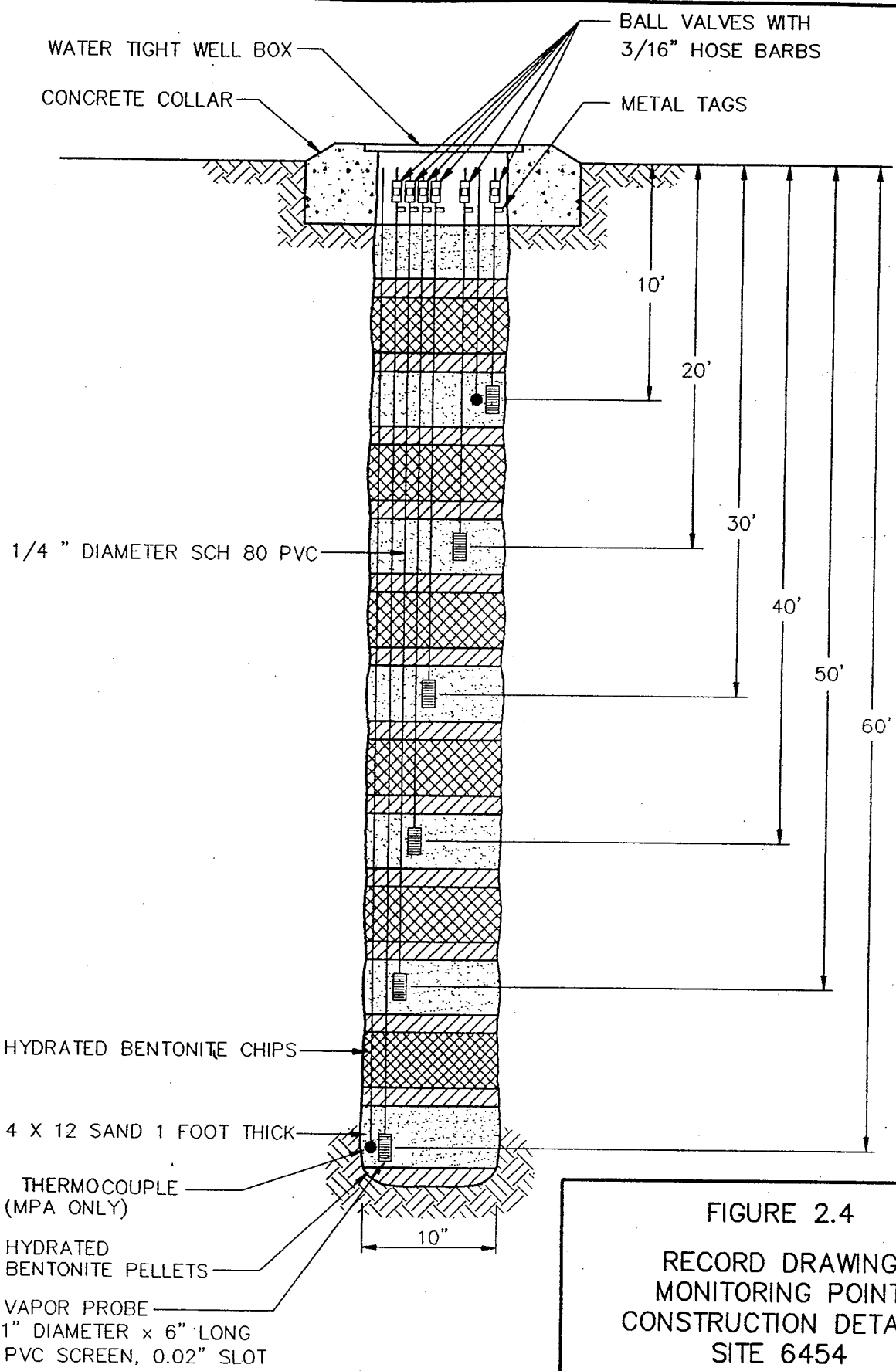

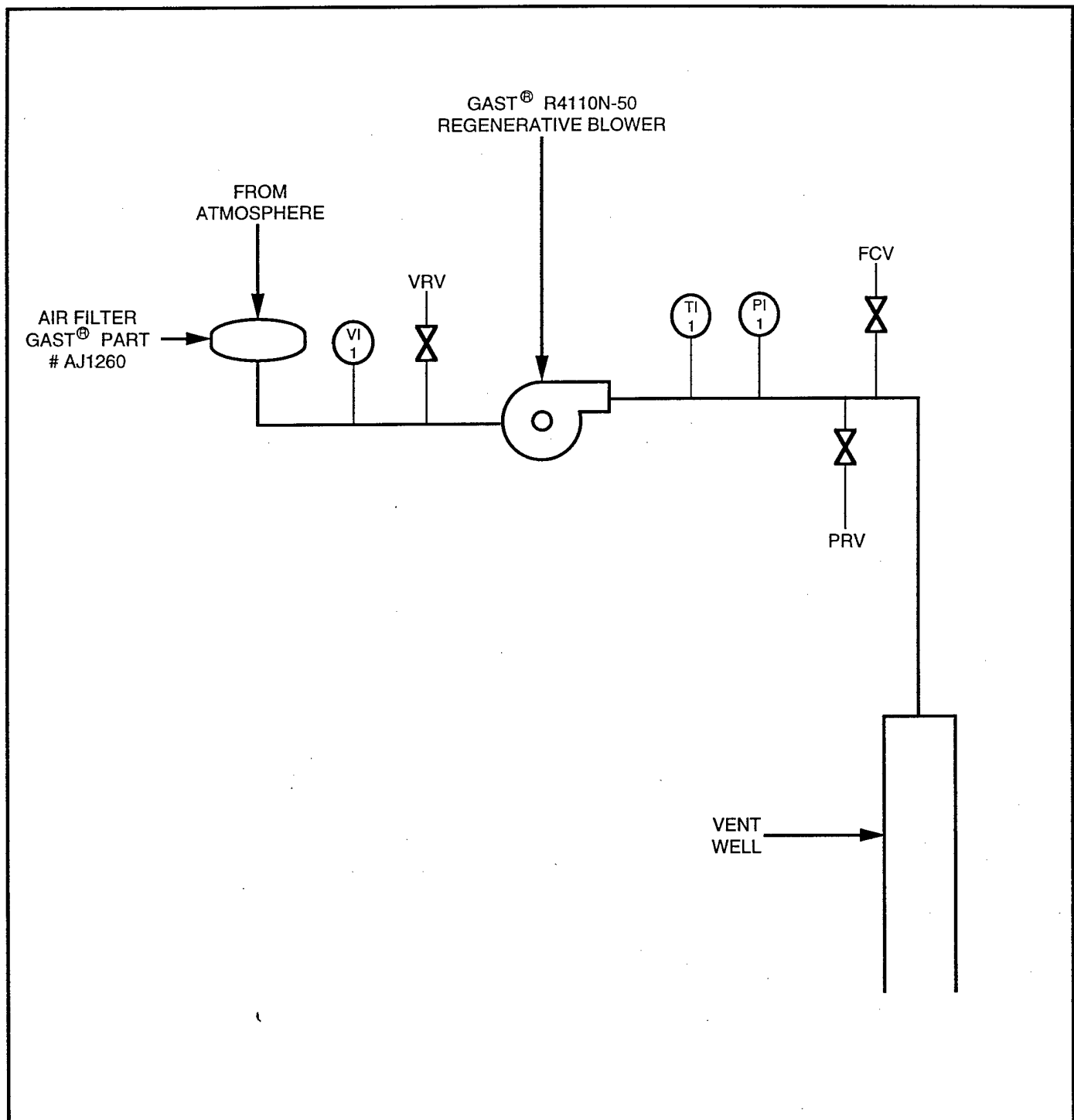

FIGURE 2.4
 RECORD DRAWING
 MONITORING POINT
 CONSTRUCTION DETAILS
 SITE 6454

VANDENBERG AFB, CALIFORNIA

ENGINEERING-SCIENCE, INC.
 Pasadena, California





LEGEND

- PRESSURE INDICATOR 0° TO 60° OF WATER, GAST® PART # AJ496
- TEMPERATURE INDICATOR 0° TO 250° F WATER, ASHCROFT® PART # 30E1
- VACUUM INDICATOR -60° TO 0° OF WATER, GAST® PART # AJ497
- FCV FLOW CONTROL VALVE, 2" PVC GATE VALVE
- PRV PRESSURE RELIEF VALVE, 30° TO 170° OF WATER, GAST® PART # AG258
- VRV VACUUM RELIEF VALVE, -170° TO 30° OF WATER, GAST® PART # AG258

FIGURE 2.5

**RECORD DRAWING BLOWER
SYSTEM FOR AIR INJECTION
SITE 6454 FORMER FUEL TRANSFER FACILITY**

VANDENBERG AFB, CALIFORNIA

ENGINEERING-SCIENCE, INC.
Pasadena, California



Soil samples for laboratory analysis were collected using an 18-inch split- spoon sampler with 2-inch diameter brass liners. Soil samples were collected from the VW at 15 feet bgs, VA2-MPA at 30 feet bgs, and VA2-MPB at 62 feet bgs.

Soil samples were shipped via Federal Express® to PACE Laboratory in Huntington Beach, California, for chemical and physical analysis. Soil samples were analyzed for total recoverable petroleum hydrocarbons (TRPH) by EPA Method 418.1; benzene, toluene, ethylbenzene, and xylenes (BTEX); iron; alkalinity; Total Kjeldahl Nitrogen (TKN); phosphates; moisture content; and grain-size analysis. Results from PACE Laboratory, using EPA Method 418.1, indicated that the soil samples collected contained little or no hydrocarbons which was contradictory to field observations of hydrocarbon readings collected using a GasTech® Tracetector® hydrocarbon meter. The laboratory indicated that, based on the benzene, toluene, ethylbenzene, and xylenes (BTEX) analysis chromatograph, the contamination seemed to be gasoline. Therefore, the laboratory requantified the soil samples as gasoline based on the EPA Method 8020 results for BTEX. The results of these analyses are provided in Table 2.1. Chain-of-Custody forms are provided in Appendix B.

2.2.2 Soil Gas Sampling Results

Soil gas samples were collected from the most contaminated MP (VA2-MPB-20), the least contaminated MP (VA2-MPC-60), and at one of the ten feet bgs intervals (VA2-MPC-10). The most and least contaminated intervals were base on field readings with the GasTech® Tracetector® hydrocarbon meter.

Soil gas samples were collected using a 3-liter Tedlar® bag and a vacuum chamber. After the samples were collected in the Tedlar® bags, they were transferred to 1-liter SUMMA® canisters and shipped to the laboratory.

Soil gas samples were shipped via Federal Express® to Air Toxics, Inc., in Folsom, California, and analyzed for total volatile hydrocarbon (TVH), and BTEX. Soil gas samples were shipped at room temperature to prevent condensation of hydrocarbons inside the SUMMA® canister. The TVH analyses were referenced to jet fuel (Molecular Weight = 156) since there is no suitable analyses for diesel. The results of these analyses are provided in Table 2.1. Chain-of-Custody forms are provided in Appendix B.

2.3 Pilot Test Results

2.3.1 Exceptions to Test Protocol Procedures

Procedures described in the protocol document and the site-specific work plan (Part I) were used to complete the pilot test at this site.

The following exceptions were made to the protocol document during this pilot test:

- The presence of a previously undescribed, buried building foundation at the site interfered with siting of the monitoring points. The points were located 20, 32, and 50 feet from the vent well and not at the distances described in the work plan (Part I of this report);
- During drilling of one of the monitoring points a barrier was encountered at 10 feet bgs. This barrier was believed to be composed of concrete. As a result of the

Table 2.1
Soil and Soil Gas Laboratory Analytical Results
Site 6454, Former Fuel Transfer Facility
Vandenberg AFB, California

Analyte (Units) ^a	Sample Location-Depth (Feet Below Ground Surface)				
	VA2-MPB-20	VA2-MPC-10	VA2-MPC-60	VA2-MPB-62	VA2-BG-9
Soil Gas Hydrocarbons					
TVH ^b (ppmv)	190,000	7,200	120,000		4.8
Benzene (ppmv)	280	9.2	33		ND(0.002)
Toluene (ppmv)	300	19	39		0.008
Ethylbenzene (ppmv)	33	11	5.0		0.006
Xylenes (ppmv)	74	20	5.9		0.046
Soil Hydrocarbons					
TRPH ^c (mg/kg)				VA2-MPA-30	VA2-MPB-62
Gasoline ^d (ppm)				ND (1.2)	ND (1.2)
Benzene (mg/kg)				ND (5.6)	ND (5.6)
Toluene (mg/kg)				0.067	0.048
Ethylbenzene (mg/kg)				0.028	0.062
Xylenes (mg/kg)				0.0036	0.007
				0.021	0.036
Soil Inorganics					
Iron(mg/kg)				VA2-MPA-30	VA2-MPB-62
Alkalinity (mg/kg as CaCO ₃ ^e)				8,540	9,390
pH (Units)				45	388
TKN ^f (mg/kg)				5.1	7.8
Phosphates (mg/kg)				58	55
				160	130
Soil Physical Parameters					
Moisture (% by wt)				VA2-MPA-30	VA2-MPB-62
Gravel (%)				12.7	12.7
Sand (%)				9.3	42.9
Silt (%)				71.6	35.4
Clay (%)				5.6	12.6
				13.5	9.2

^a ppmv = parts per million, volume per volume; mg/kg = milligrams per kilogram

^b TVH = total volatile hydrocarbons

^c TRPH = total recoverable petroleum hydrocarbons by EPA 418.1

^d Based on chromatography obtained in EPA 8020 analysis

^e CaCO₃ = calcium carbonate

^f TKN = total Kjeldahl nitrogen

ND = non-detect. Detection limits are in parentheses

NA = not analyzed

obstruction, this borehole was backfilled with bentonite chips and abandoned. This borehole was designated SB-1;

- At the request of the client EPA Method 8010 was performed on the soil samples collected at VA2-VW-15, VA2-MPA-30, and VA2-MPC-62. The results of this analyses are listed in Table 2.2.

- A soil gas sample was not collected at the vent well although one was collected at the background point because a permanent background point could not be installed.

Table 2.2
Laboratory Analytical Results for EPA Method 8010
Site 6454, Former Fuel Transfer Facility
Vandenberg AFB, California

Soil Sample Identification	EPA Method 8010 Constituent ^{*1}	Result (mg/kg)
VA2-MPA-30	1,2-Dichloroethane	0.0164
VA2-MPB-62	1,2-Dichloroethane	0.0324

* VA2-VW-15 was non-detect for all EPA Method 8010 Constituents

¹ Detected constituents only

2.3.2 Initial Soil Gas Chemistry

Prior to initiation of air injection for the respiration test, the VW and all MPs were purged, and initial oxygen, carbon dioxide, and TVH concentrations were measured using portable gas analyzers, as described in the protocol document.

Table 2.3 summarizes the initial soil gas chemistry at the site. The results indicate that biological fuel degradation has depleted the oxygen supply in the vadose zone at many of the sampling points. Field readings showed the VW and MPs contained oxygen levels varying from 0 to 19.5 percent. Carbon dioxide was present at concentrations ranging from 0.05 to 16 percent. It should be noted that in the sampling points where oxygen levels are near atmospheric concentrations there may be residual oxygen that was introduced during drilling operations two to six days before the initial concentrations were measured.

A background soil gas sample was collected at 9 feet bgs approximately 200 feet south of the site. This sample was obtained by driving a soil gas probe into the ground to refusal and extracting a sample by procedures described in the protocol document. The formation encountered at 9 feet bgs at this location was very tight, making collection of a sufficient quantity of sample difficult. Therefore, no analysis of this gas was performed in the field using the GasTech[®] Tracetector[®] hydrocarbon meter. However, oxygen and carbon dioxide measurements were collected and indicated that some oxygen depletion was present but not significant. Lab analysis of the sample indicated a small quantity of volatile hydrocarbons were present.

Table 2.3
Initial Soil Gas Chemistry
Site 6454, Former Fuel Transfer Facility
Vandenberg AFB, California

Sample Location	Depth (ft bgs)	O ₂ (percent)	CO ₂ (percent)	TVH-Field (ppmv) ^a	TVH-Lab (ppmv) ^b	Temperature (°F)
VA2-VW	4-75	19.5	0.2	80	NA	NA
VA2-MPA-10	10	5.5	0.1	>20,000	NA	62.3
VA2-MPA-20	20	5.0	0.08	>20,000	NA	NA
VA2-MPA-30	30	0.0	1.9	>20,000	NA	NA
VA2-MPA-40	40	0.0	4.8	16,400	NA	NA
VA2-MPA-50	50	0.0	7.5	>20,000	NA	NA
VA2-MPA-60	60	0.0	11.0	>20,000	NA	66
VA2-MPB-10	10	14.0	0.05	4,000	NA	NA
VA2-MPB-20	20	5.0	3.5	>20,000	190,000	NA
VA2-MPB-30	30	3.5	10.0	>20,000	NA	NA
VA2-MPB-40	40	4.0	0.05	>20,000	NA	NA
VA2-MPB-50	50	0.0	4.4	>20,000	NA	NA
VA2-MPB-60	60	0.0	9.0	>20,000	NA	NA
VA2-MPC-10	10	16.0	0.9	580	7,200	NA
VA2-MPC-20	20	2.5	14.5	2,000	NA	NA
VA2-MPC-30	30	0.0	16.0	>20,000	NA	NA
VA2-MPC-40	40	0.0	15.5	>20,000	NA	NA
VA2-MPC-50	50	7.5	7.5	>20,000	NA	NA
VA2-MPC-60	60	0.0	4.0	>20,000	120,000	NA
VA2-BG-9	9	15.0	3.0	NA*	4.8	NA

^a Total hydrocarbon analyzer field screening results.

^b Laboratory results referenced to Jet Fuel (Molecular Weight = 156)

NA = Not Analyzed

* Not Analyzed due to insufficient volume of sample

2.3.3 *In-Situ* Respiration Rates

An *in-situ* respiration test was conducted at the site according to protocol document procedures. Gast® 1-cfm pumps were used to inject air into VA2-MPA at 10 and 40 feet bgs, VA2-MPB at 20 and 50 feet bgs, and VA2-MPC at 30 and 60 feet bgs for 20.5 hours. Helium, at a concentration of approximately 3 percent, was used as a tracer gas and injected into the same points in order to gauge soil gas diffusion. After air injection ceased, oxygen concentrations in the MPs ranged from 19.0 to 20.0 percent and changes in soil gas composition were monitored over time. Oxygen, carbon dioxide, TVH, and helium were measured over a period of 67 hours following the air injection period. The observed rate of oxygen utilization was then used to estimate the aerobic fuel degradation rate at the site using procedures outlined in Section 5.7 of the protocol document. Table 2.4 provides a summary of the observed

Table 2.4
Oxygen Utilization Rates
Site 6454, Former Fuel Transfer Facility
Vandenberg AFB, California

Location	O ₂ Loss (percent)	Test Duration (hours)	O ₂ Utilization Rate ^a (percent/hour)	Hydrocarbon Degradation Rate (mg/kg/yr)
VA2-MPA-10	5.0	91.42	0.041	70
VA2-MPA-40	11.0	91.55	0.12	490
VA2-MPB-20	1.5	91.62	0.024	50
VA2-MPB-50	11.3	91.75	0.11	490
VA2-MPC-30	8.5	92.38	0.082	130
VA2-MPC-60	12.3	92.00	0.12	540

^a Value based on linear regression (Figure 2.6 - 2.11)

oxygen utilization rate and Figures 2.6 through 2.11 provide the results of *in-situ* respiration testing at the site. Additionally, six month and one year respiration tests will be conducted by ES personnel.

At site 6454, an estimated 50 to 540 milligrams of fuel per kilogram of soil (mg/kg) can be degraded each year. These values were calculated using the observed oxygen utilization rates and an estimated air-filled porosity of 0.057 to 0.129 liters per kilogram of soil and a conservative ratio of 3.5 mg of oxygen consumed for every 1 mg of fuel biodegraded. Oxygen decrease during the respiration was relatively constant in the monitoring points between 40 and 60 feet bgs.

2.3.4 Air Permeability Test

An air permeability test was conducted at the site according to the protocol document procedures. Air was injected into the VW for approximately 20 hours at a rate of 60 scfm. At this flow rate, pressure response was seen in all three MPs, as shown in Table 2.5. The dynamic method of determining air permeability is coded in the HyperVentilate[®] model that was used to calculate soil gas permeability values. These values ranged from 3 darcys for clayey sand to 319 darcys for sand at this site. A minimum radius of pressure influence of 50 feet was observed at all depths except the 10 foot depths at MPB and MPC, and the 30 foot depth at MPB. These depths correspond to clay or sandy clay intervals (See Figure 2.2).

2.3.5 Oxygen Influence

The depth and radius of oxygen influence in the subsurface resulting from air injection into the VW during pilot testing is the primary design parameter for full-scale bioventing systems. Optimization of full-scale and multiple VW systems requires pilot testing to determine the volume of soil that can be oxygenated at a given flow rate and VW screen configuration.

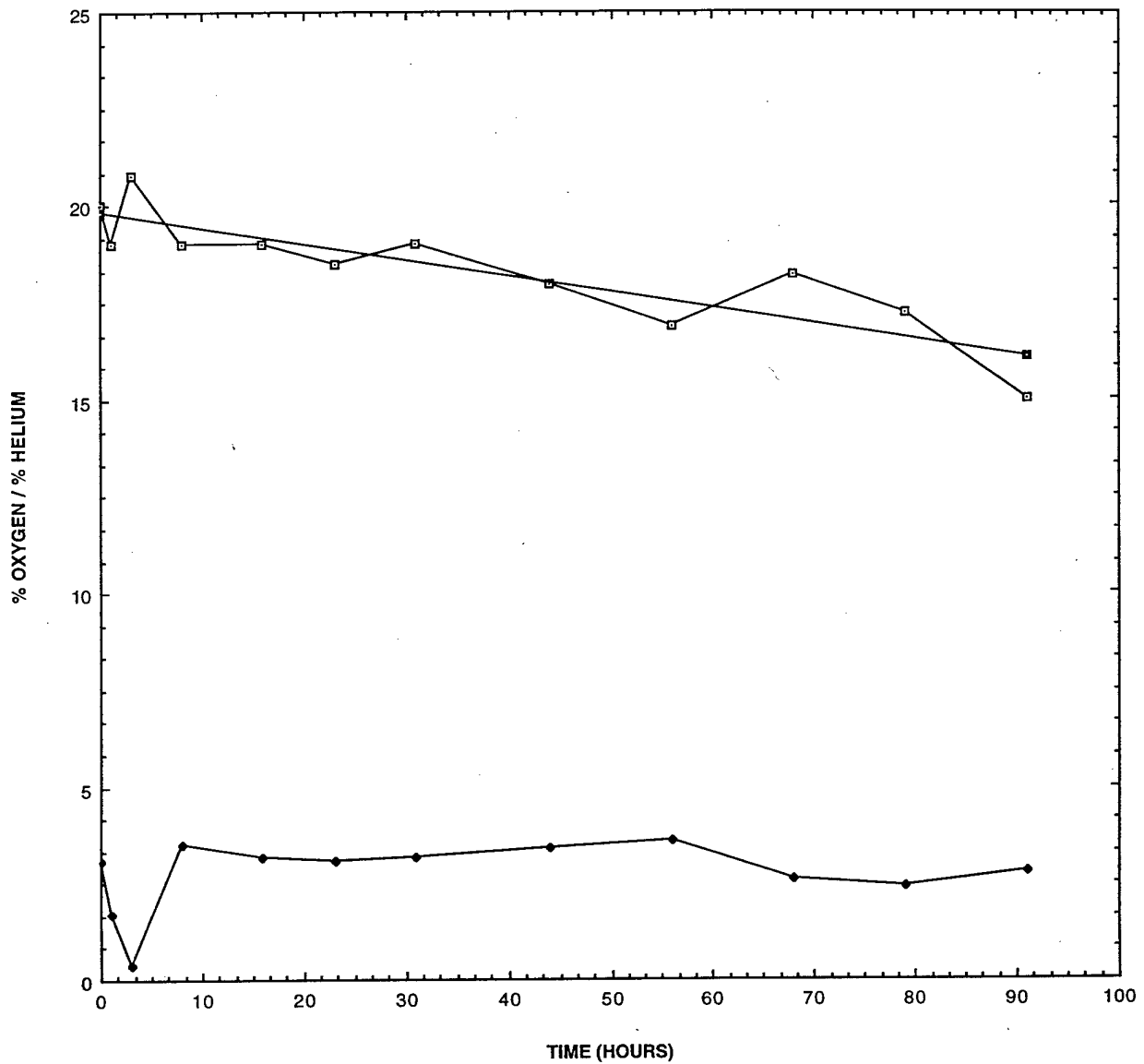

LEGEND

- % OXYGEN
- ♦— % HELIUM
- ▲— OXYGEN UTILIZATION (k = 0.0414 % O2/hour)

FIGURE 2.6

**RESPIRATION TEST, VA2-MPA-10
SITE 6454 FORMER FUEL TRANSFER FACILITY**

VANDENBERG AFB, CALIFORNIA

ENGINEERING-SCIENCE, INC.
Pasadena, California



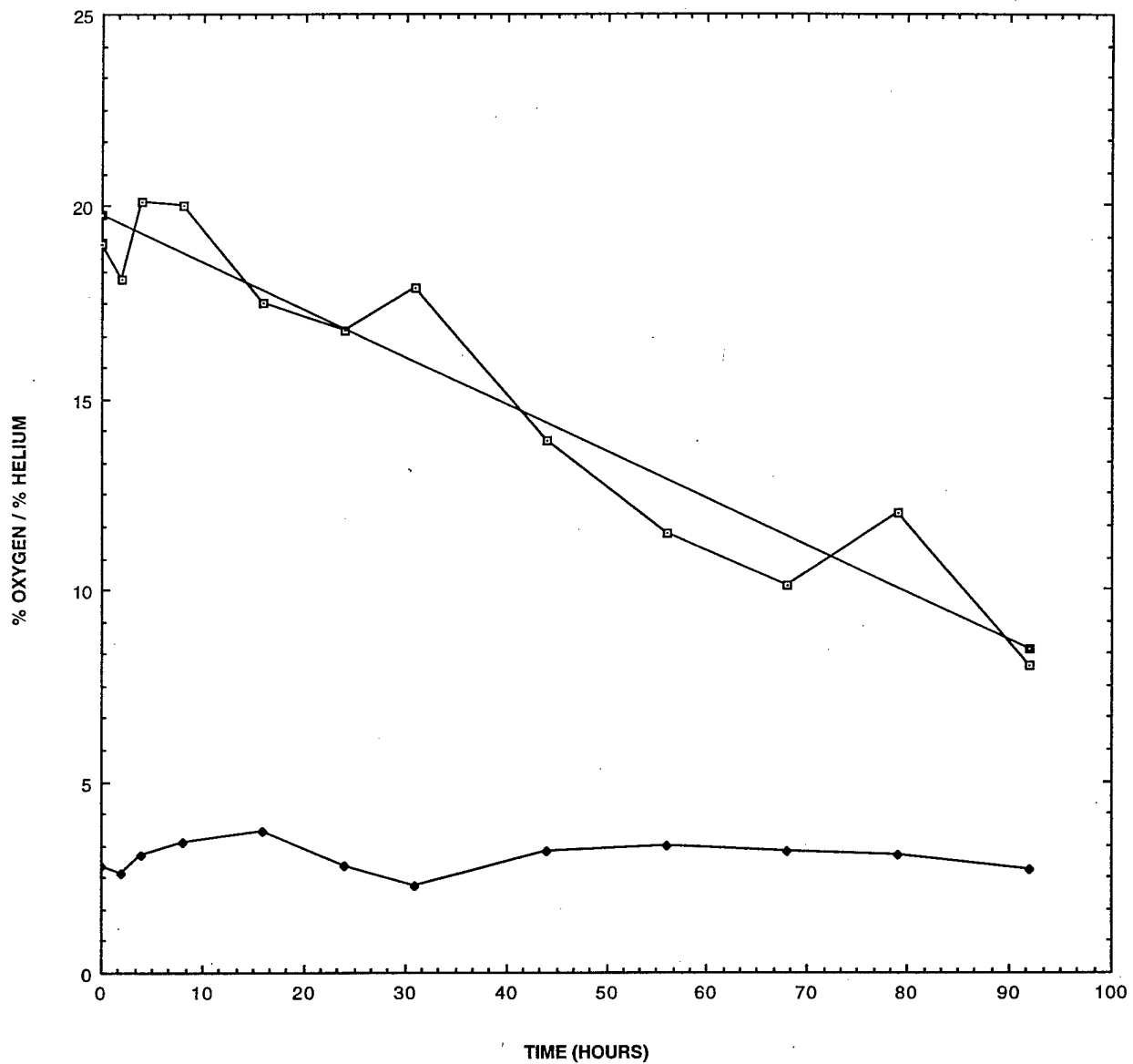

LEGEND

- % OXYGEN
- ♦— % HELIUM
- OXYGEN UTILIZATION (k = 0.1232 % O₂/hour)

FIGURE 2.7

**RESPIRATION TEST, VA2-MPA-40
SITE 6454 FORMER FUEL TRANSFER FACILITY**

VANDENBERG AFB, CALIFORNIA

ENGINEERING-SCIENCE, INC.
Pasadena, California



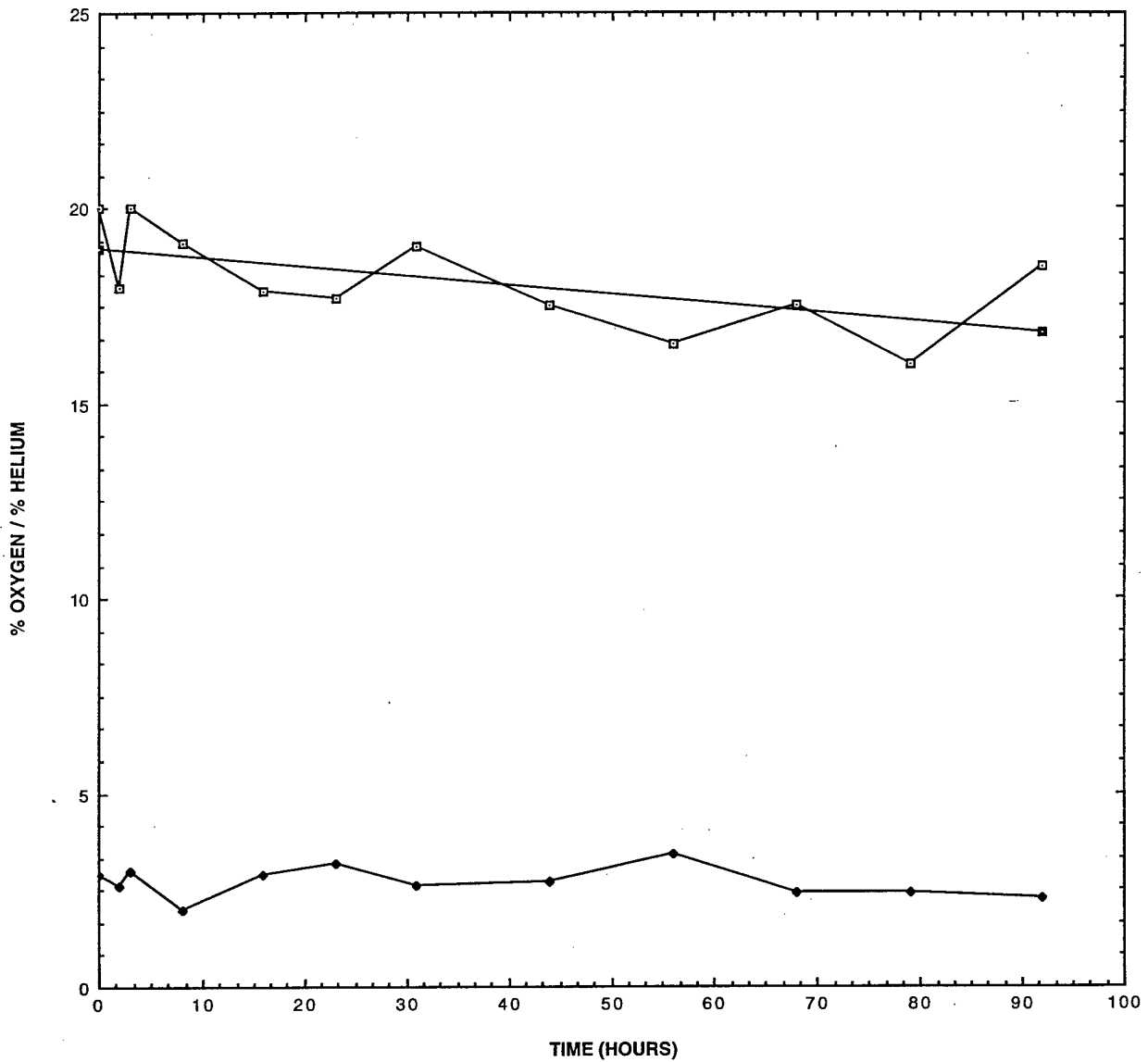

LEGEND

- % OXYGEN
- ◆— % HELIUM
- ▲— OXYGEN UTILIZATION ($k = 0.0241$ % O₂/hour)

FIGURE 2.8

**RESPIRATION TEST, VA2-MPB-20
SITE 6454 FORMER FUEL TRANSFER FACILITY**

VANDENBERG AFB, CALIFORNIA

ENGINEERING-SCIENCE, INC.
Pasadena, California



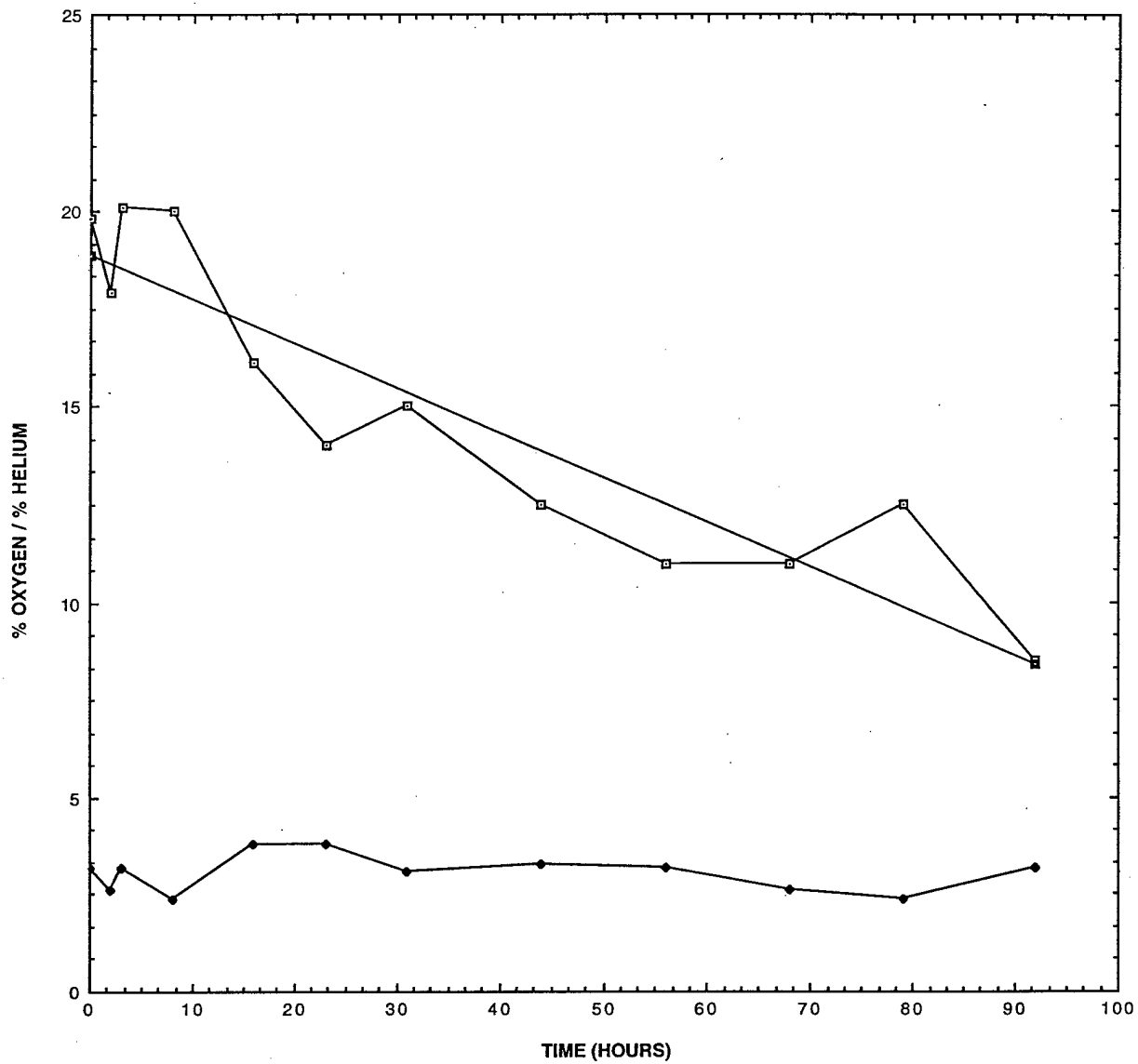

LEGEND

- % OXYGEN
- % HELIUM
- ▲— OXYGEN UTILIZATION ($k = 0.1133 \% O_2/\text{hour}$)

FIGURE 2.9

**RESPIRATION TEST, VA2-MPB-50
SITE 6454 FORMER FUEL TRANSFER FACILITY
VANDENBERG AFB, CALIFORNIA**

ENGINEERING-SCIENCE, INC.
Pasadena, California



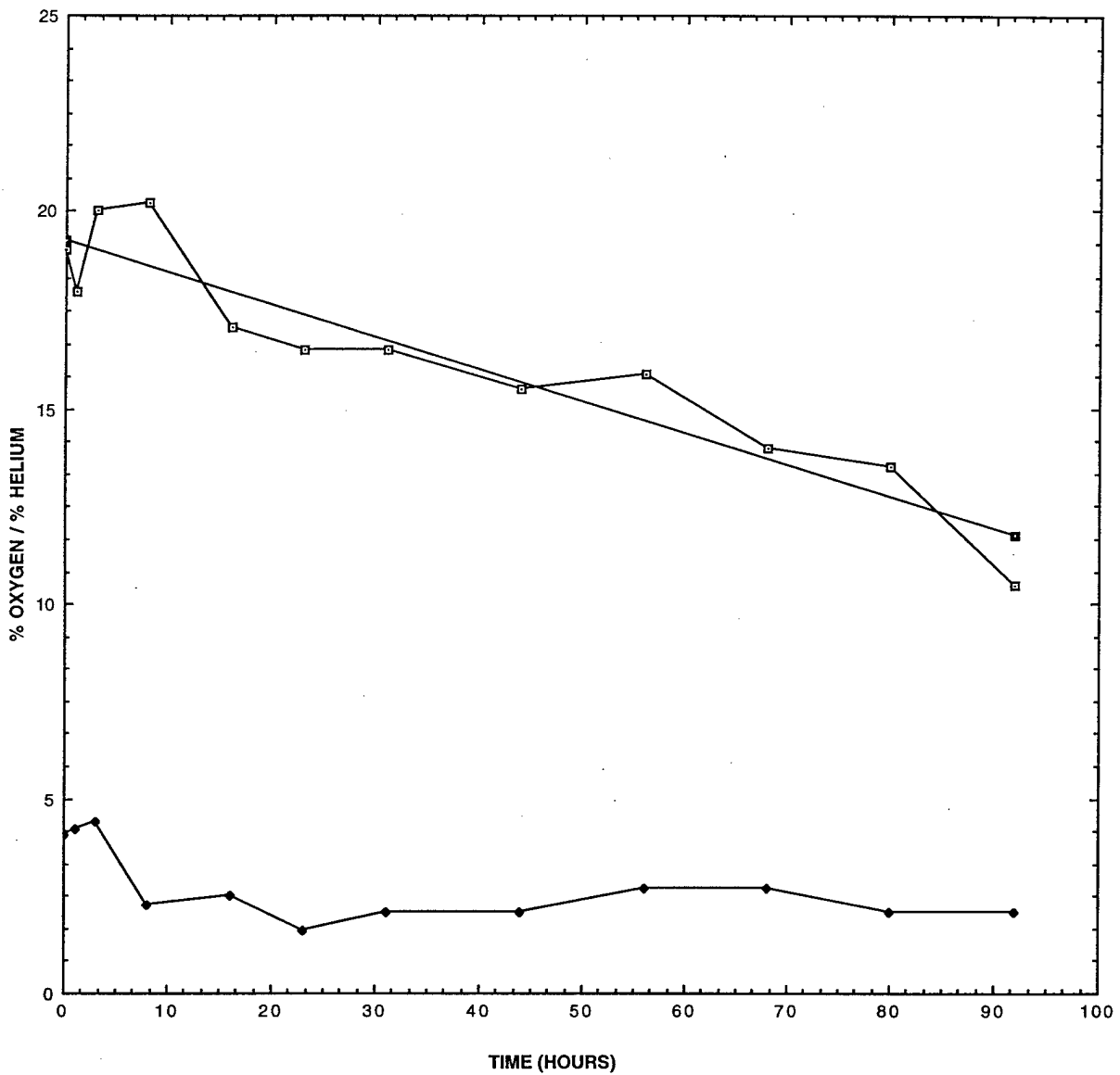

LEGEND

- % OXYGEN
- ◆— % HELIUM
- OXYGEN UTILIZATION (k = 0.0817 % O2/hour)

FIGURE 2.10

**RESPIRATION TEST, VA2-MPC-30
SITE 6454 FORMER FUEL TRANSFER FACILITY**

VANDENBERG AFB, CALIFORNIA

ENGINEERING-SCIENCE, INC.
Pasadena, California



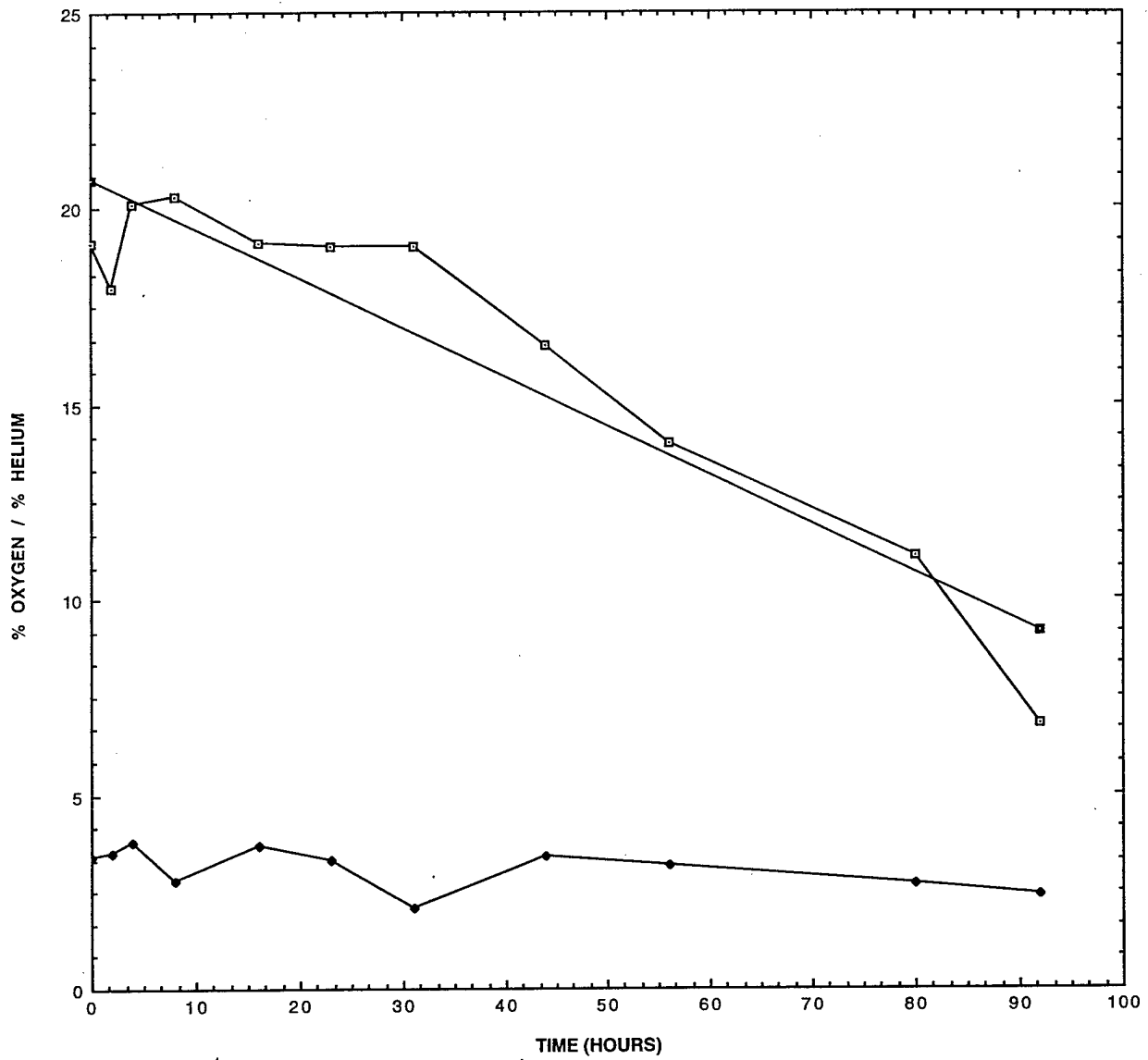

LEGEND

- % OXYGEN
- ♦— % HELIUM
- OXYGEN UTILIZATION (k = 0.1258 % O2/hour)

FIGURE 2.11

**RESPIRATION TEST, VA2-MPC-60
SITE 6454 FORMER FUEL TRANSFER FACILITY**

VANDENBERG AFB, CALIFORNIA

ENGINEERING-SCIENCE, INC.
Pasadena, California



Table 2.6 describes the change in soil gas oxygen levels that occurred after 20 hours of air injection during the air permeability test as well as the change in oxygen concentrations after 524 hours (22 days) of air injection. The extended oxygen levels were included to show that oxygen influence was achieved at all monitoring points at all depths. In the cases where oxygen levels dropped from the final to extended readings, one possible explanation is that the outward movement of oxygen depleted soil gas is occurring which could reduce the oxygen levels from the final to extended readings. The air injection flow rate of 60 scfm produced an increase in soil gas oxygen levels at a distance of at least 50 feet from the VW. Based on oxygen influence during testing, it is anticipated that the radius of influence for a long-term bioventing system at this site will exceed 50 feet at all depths.

2.3.6 Potential Air Emissions

Due to site contamination consisting primarily of jet fuel (JP-4), a compound of relatively low volatility, air emissions should be relatively low. Also, emissions will generally be highest during the first day of air injection when the initial soil gas volume is displaced. Based on field measurements of 0.0 ppmv volatiles taken with a photoionization detector (PID) during the air permeability test (the first day of air injection) and because horizontal permeability is generally greater than vertical permeability, the long-term potential for air emissions from bioventing operations at this site is low.

2.4 Recommendations

Initial bioventing tests at this site indicate that oxygen had been depleted in the subsurface and that air injection is an effective method of stimulating aerobic fuel biodegradation. AFCEE has recommended that air injection continue at this site to determine the long-term radius of oxygen influence and the effects of time, available nutrients, and changing temperatures on fuel biodegradation rates.

A 1-horsepower regenerative blower has been installed at the site for continuous air injection. In August 1994, ES will return to the site to sample and analyze the soil gas and conduct a repeat respiration test. In March 1995, a final respiration test will be conducted and soil and soil gas samples will be collected from the site to determine the degree of remediation achieved during the first year of *in-situ* treatment.

Based on results presented by ES for the first year of pilot-scale bioventing, AFCEE will recommend one of two options for the site:

1. Upgrade, if necessary, and continue operation of the bioventing system for full-scale remediation of the site.
2. If significant difficulties or poor results are encountered during bioventing at this site, AFCEE may recommend removal of the blower system and proper abandonment of the VW and MPs.

Table 2.6
Influence of Air Injection Vent Well on Monitoring Point Oxygen Levels
Site 6454, Former Fuel Transfer Facility
Vandenberg AFB, California

Sample Location	Distance from VW (ft)	Depth (ft bgs)	Initial O ₂ (percent)	Final O ₂ ^a (percent)	Extended O ₂ ^b (percent)
VA2-MPA-10	20	10	5.5	14.5	12.1
VA2-MPA-20	20	20	5.0	12.3	4.3
VA2-MPA-30	20	30	0.0	9.5	5.5
VA2-MPA-40	20	40	0.0	0.0	6.5
VA2-MPA-50	20	50	0.0	3.0	5.9
VA2-MPA-60	20	60	0.0	0.0	1.7
VA2-MPB-10	32	10	14.0	13.3	16.5
VA2-MPB-20	32	20	5.0	15.5	16.1
VA2-MPB-30	32	30	3.5	9.3	NA
VA2-MPB-40	32	40	4.0	6.5	5.5
VA2-MPB-50	32	50	0.0	4.8	0.75
VA2-MPB-60	32	60	0.0	0.0	0.5
VA2-MPC-10	50	10	16.0	9.2	3.0
VA2-MPC-20	50	20	2.5	9.9	10.0
VA2-MPC-30	50	30	0.0	11.5	9.0
VA2-MPC-40	50	40	0.0	8.8	6.5
VA2-MPC-50	50	50	7.5	9.2	9.0
VA2-MPC-60	50	60	0.0	5.0	8.0

^a Readings taken after 20 hours of air injection during air permeability test.

^b Readings taken 524 hours after conclusion of air permeability test

NS = Not Sampled

3.0 REFERENCES

Engineering-Science, Inc. *Field Sampling Plan for AFCEE Bioventing*. Denver, Colorado. 1992.

Hinchee, R.E., Ong, S.K., Miller, R.N., Downey, D.C., and Frandt, R. *Test Plan and Technical Protocol for a Field Treatability Test for Bioventing*. January, 1992.

Bureau of Reclamation 1993. Site Characterization Analytical Results.

Bureau of Reclamation 1994. Interim Report of the Remedial Investigation of Facility 6454.

APPENDIX A
OPERATION & MAINTENANCE MANUAL

**REGENERATIVE BLOWER
OPERATIONS AND MAINTENANCE MANUAL
FOR EXTENDED TESTING SYSTEM AT
VANDENBERG AIR FORCE BASE,
SITE 6454**

Prepared for:

**AIR FORCE CENTER FOR ENVIRONMENTAL EXCELLENCE
BROOKS AFB, TEXAS**

USAF CONTRACT F33615-90-D-40140, DELIVERY ORDER 14

MAY 1994

Prepared by:

**Engineering-Science, Inc.
199 South Los Robles Avenue
Pasadena, California**

SECTION 1

INTRODUCTION

This document has been prepared by Engineering-Science, Inc., to support the bioventing initiative contract awarded by the Air Force Center for Environmental Excellence. The contract involves the conducting of bioventing pilot tests at 135 sites on 23 Air Force Bases across the United States.

At most sites, bioventing systems will be installed upon completion of the bioventing pilot tests for the purpose of extended pilot testing. These systems will operate for a one year period to provide further information as to the feasibility of the technology at each site, and to provide interim remedial action.

The Operations and Maintenance Manual has been created for sites at which blowers have been installed for extended pilot testing. Basic maintenance of these systems is the responsibility of the base. The manual is to be used by base personnel to guide and assist them in operating and maintaining the blower system. Section 2 provides a synopsis of the blower system configuration. Section 3 of this document describes the blower. Section 4 details the maintenance requirements and provides maintenance schedules. Section 5 describes the system monitoring that is required to forecast system maintenance needs and provide data for the extended pilot test.

SECTION 2

BLOWER SYSTEM CONFIGURATION SUMMARY

System Type injection

Blower regenerative

Blower Model R4110N-50

Motor (Horsepower) 1.0

Knock-Out Chamber none

Sampling Port none

Inlet Temperature Gauge (range) not applicable

Inlet Vacuum Gauge (range) -60" - 0" H₂O

Inlet Filter (part no.) AJ134E

Outlet Temperature Gauge (range) 0°-250° F

Outlet Pressure Gauge (range) 0" - 60" H₂O

Pressure/Vacuum Relief Valve Set @ (give unit of measure) 30" H₂O

SECTION 3

BIOVENTING SYSTEM OPERATION

3.1 PRINCIPLE OF OPERATION

Bioventing is the forced injection of fresh air, or withdrawal of soil gas, to enhance the supply of oxygen for *in situ* bioremediation. Either a pressure (air injection) or vacuum (vapor extraction) blower unit is used to inject or withdraw air into or from the soil, thereby supplying fresh air with 20.8 percent oxygen to the contaminated soils. Once oxygen is provided to the subsurface, existing bacteria will proceed with the breakdown of fuel residuals.

An injection blower system has been installed at Vandenberg Air Force Base Site 6454.

3.2 SYSTEM DESCRIPTION

3.2.1 Blower System

A Gast series R4 blower powered by a one horsepower direct-drive motor is the workhorse of this bioventing system. This blower is rated at a flow rate of 92 standard cubic feet per minute (scfm) at open flow; however, the actual performance of the blower will vary with changing site conditions. As installed at Site 6454 the blower was producing an estimated flow rate of 68 scfm at a pressure of 25 inches of water. The system includes an air filter to remove any particulates which are entrained in the air stream, and several valves and monitoring gauges which are described in the next section. A schematic of the blower system installed at Site 6454 is shown on the figure in Attachment A. Corresponding blower performance curves, and relevant service information are also provided there.

3.2.2 Monitoring Gauges

The bioventing system is equipped with vacuum, pressure, and temperature gauges. Gauges have been installed on the air injection system at the following locations: a vacuum gauge in the inlet piping, a pressure and a temperature gauge in the outlet piping. The temperature gauge is used to monitor the outlet temperature to determine the change in temperature across the blower. Ambient air temperature can be estimated and used as the inlet temperature since an inlet temperature gauge is not present. See the figure in the attachment for the locations of the gauges installed on the blower system.

SECTION 4

SYSTEM MAINTENANCE

Although the motor and blower are relatively maintenance free, periodic system maintenance is required for proper operation and long life. Recommended maintenance procedures and schedules are described in detail in the instruction manuals included in Attachments A and B and briefly summarized in this section.

Filter inspection must be performed with the system turned off. To re-start the motor, open the manual air dilution valve to protect the motor from excessive strain, start motor, and slowly close dilution valve. If the handle has been removed from the manual air dilution valve, do not open the valve or otherwise change the setting (it has been pre-set for a specific flow rate) before re-starting the blower.

4.1 BLOWER/MOTOR

The blower and motor are relatively maintenance free and should not require any periodic maintenance during the 1-year extended testing period. Both blower and motor have sealed bearings and do not require lubrication.

4.2 AIR FILTER

To avoid damage caused by passing solids through the blower, an air filter has been installed in-line before the blower. The filter element is paper and is accompanied by a polyurethane foam prefilter. The filter should be checked weekly for the first 2 months of operation. Again, a facility employee should determine the best schedule for filter replacement. The polyurethane prefilters can be washed with lukewarm water and a mild detergent. Paper filter elements should never be washed, but should be disposed of and replaced as necessary. When the pressure or vacuum drop across the blower is above 25 inches of water, a dirty filter element should be suspected, and cleaning or replacement should be performed.

To remove the filter, loosen the wing nut, lift the metal top off the air filter, and lift the air filter from the metal housing. Remove the polyurethane prefilter (if applicable) and wash before replacing. When replacing the filter, be careful that the rubber seals remain in place.

The filter element is manufactured by Gast Manufacturing Corp. in Benton Harbor, Michigan. Their telephone number is (616) 926-6171. Additional filters can also be obtained through Engineering-Science, Inc., in Pasadena, California. The ES contact is Mr. Chris Pluhar. He can be reached at (818) 585-6324. The filter model number

is AJ126D, and the number for the replacement element is AJ134E. It is recommended that at least one spare air filter be kept at the site, four spare filters were supplied with the blower system.

4.3 MAINTENANCE SCHEDULE

The following maintenance schedule is recommended for this system. The filter should be checked once per month and washed or replaced as necessary (see Section 5.2). During the initial months of operation more frequent monitoring is recommended to ensure that any startup problems are quickly corrected. A daily drive-by inspection is recommended during the initial 2 weeks of operation to ensure that the blower system is still operating with no unusual sounds. Data collection sheets that can be used to record maintenance activities are included in Attachment B.

4.4 TROUBLESHOOTING

<u>Symptoms</u>	<u>Possible Diagnosis</u>	<u>Possible Remedy</u>
Excess Vibration	Impeller damaged by foreign material Impeller contaminated by foreign material	Replace impeller Clean impeller, install adequate filtration
Abnormal Sound	Motor bearing failed Impeller rubbing against cover or housing	Replace bearings Repair blower, check clearances
Increase in Sound	Foreign material can coat or destroy muffler foam	Replace foam muffler elements, trap or filter foreign material
Blown Fuse	Electrical wiring problem	Have qualified person check fuse capacity and wiring
Unit Very Hot	Running at too high a pressure or vacuum	Install or adjust relief valves

4.5 MAJOR REPAIRS

Blowers systems are very reliable when properly maintained. Occasionally, a motor or blower will develop a serious problem. If a blower system fails to start, and a qualified electrician verifies that power is available at the blower or starter, the ES Site Manager, Chris Pluhar, should be called at (818) 585-6324. ES is responsible for major repairs during the first year of operation.

SECTION 5

SYSTEM MONITORING

5.1 BLOWER PERFORMANCE MONITORING

To monitor the blower performance, vacuum, pressure, and temperature will be measured. These data should be recorded weekly on a data collection sheet (provided in Attachment B). All measurements should be taken at the same time while the system is running. Because the system is loud, hearing protection should be worn at all times.

5.1.1 Vacuum/Pressure

With hearing protection in place, open the blower enclosure and record all vacuum and pressure readings directly from the gauges (in inches of water or psi). Record the measurements on a data collection sheet (Attachment B).

5.1.2 Flow Rate

The flow rate through the vent well and soils can be calculated when the inlet vacuum and outlet pressure of the blower are known. This pressure change across the blower (vacuum + pressure) can be compared to the performance curves for the blower in Attachment A to determine the approximate flow rate.

5.1.3 Temperature

With hearing protection in place, open the blower enclosure and record the temperature readings directly from the gauges in degrees Fahrenheit (°F). Record the measurements on a data collection sheet (provided in Attachment B). The temperature change can be converted to degrees Celsius (°C) using the formula $^{\circ}\text{C} = (^{\circ}\text{F} - 32) \times 5/9$.

5.3 MONITORING SCHEDULE

The following monitoring schedule is recommended for this system. During the initial months of operation, more frequent monitoring is recommended to ensure that any start up problems are quickly corrected. Data collection sheets have been provided to assist your data collection and are included in Attachment B.

Monitoring Item

Monitoring Frequency

Vacuum/Pressure

Once per week.

Temperature

Once per week.



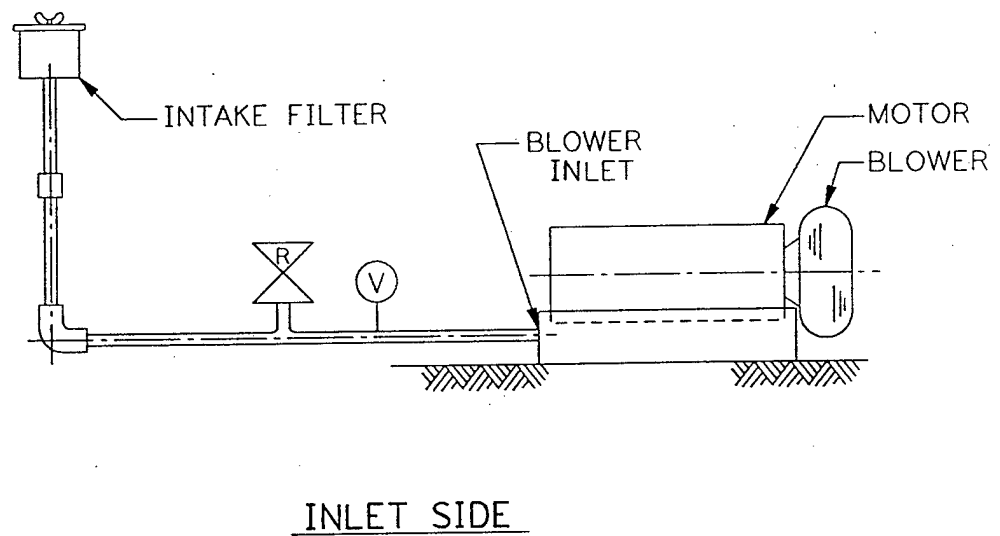
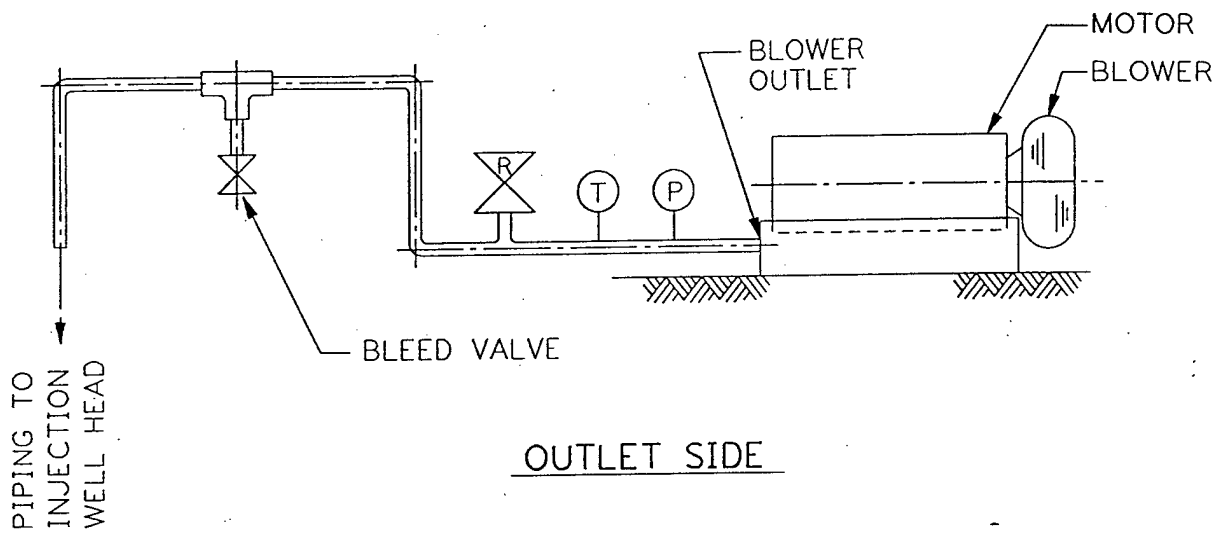

Air Filter

Clean as needed.

ATTACHMENT A



LEGEND

-  TEMPERATURE GAUGE (1/4" NPT)
-  PRESSURE GAUGE (1/4" NPT)
-  VACUUM GAUGE (1/4" NPT)
-  PRESSURE OR VACUUM RELIEF VALVE

REGENERATIVE BLOWER
SYSTEM FOR AIR
INJECTION

NOT TO SCALE

ENGINEERING-SCIENCE, INC.
Pasadena, California





70-6100
F2-205/8/92
Rev. E

Post Office Box 97
Benton Harbor, MI. 49023-0097
Ph: 616/926-6171
Fax: 616/925-8288

INSTALLATION AND OPERATING INSTRUCTIONS FOR GAST HAZARDOUS DUTY REGENAIR BLOWERS

This instruction applies to the following models ONLY: R3105N-50, R4110N-50, R4310P-50, R4P115N-50, R5125Q-50, R5325R-50, R6130Q-50, R6P155Q-50, R6350R-50, R6P355R-50 and R7100R-50.

Gast Authorized Service Facilities are Located in the locations listed below

Gast Manufacturing Corporation
505 Washington Avenue
Carlstadt, N. J. 07072
Ph: 201/933-8484
Fax: 201/933-5545

Gast Manufacturing Corporation
2550 Meadowbrook Road
Benton Harbor, MI. 49022
Ph: 616/926-6171
Fax: 616/925-8268

Brenner Fiedler & Associates
13824 Bentley Place
Cerritos, CA. 90701
Ph: 310/404-2721
Ph: 800/843-5558
Fax: 310/404-7975

Wainbee Limited
215 Brunswick Blvd.
Pointe Claire, Quebec
Canada H9R 4R7
Ph: 514/697-8810
Fax: 514/697-3070

Wainbee Limited
5789 Coopers Ave.
Mississauga, Ontario
Canada L4Z 3S6
Ph: 416/243-1900
Fax: 416/243-2336

Japan Machinery
Central PO Box 1451
Toyko 100-91, Japan
Ph: 813 3573-5421
Fax: 813 3571-7896

Gast Manufacturing Co. Ltd.
Halifax Road, Cressex Estate
High Wycombe, Bucks HP12 3SN
England
Ph: 44 494 523571
Fax: 44 494 436588

OPERATING AND MAINTENANCE INSTRUCTIONS

SAFETY

This is the safety alert symbol. When you see this symbol personal injury is possible. The degree of injury is shown by the following signal words:

- ⚠ DANGER** Severe injury or death will occur if hazard is ignored.
- ⚠ WARNING** Severe injury or death can occur if hazard is ignored.
- ⚠ CAUTION** Minor injury or property damage can occur if hazard is ignored.

Review the following information carefully before operating.

GENERAL INFORMATION

This instruction applies to the following models ONLY: R3105N-50, R4110N-50, R4310P-50, R4P115N-50, R5125Q-50, R5325R-50, R6130Q-50, R6P155Q-50, R6350R-50, R6P355R-50 and R7100R-50. These blowers are intended for use in Soil Vapor Extraction Systems. The blowers are sealed at the factory for very low leakage. They are powered with a U.L. listed electric motor Class 1 Div. 1 Group D motors for Hazardous Duty locations. Ambient temperature for normal full load operation should not exceed 40° C (105° F). For higher ambient operation, contact the factory.

Gast Manufacturing Corporation may offer general application guidance: however, suitability of the particular blower and/or accessories is ultimately the responsibility of the user, not the manufacturer of the blower.

INSTALLATION

- ⚠ DANGER** Models R5325R-50, R6130Q-50, R6350R-50, R5125Q-50, R6P155Q-50, R6P355R-50 AND R7100R-50 use Pilot Duty Thermal Overload Protection. Connecting this protection to the proper control circuitry is mandated by UL674 and NEC501. Failure to do so could/ may result in a EXPLOSION. See pages 3 and 4 for recommended wiring schematic for these models.

- ⚠ WARNING** Electric shock can result from bad wiring. A qualified person must install all wiring, conforming to all required safety codes. Grounding is necessary.

- ⚠ WARNING** This blower is intended for use on soil vapor extraction equipment. Any other use must be approved in writing by Gast Manufacturing, Corp. Install this blower in any mounting position. Do not block the flow of cooling air over the blower and motor.

PLUMBING - Use the threaded pipe ports for connection only. They will not support the plumbing. Be sure to use the same or larger size pipe to prevent air flow restriction and overheating of the blower. When installing fittings, be sure to use pipe thread sealant. This protects the threads in the blower housing and prevents leakage. Dirt and chips are often found in new plumbing. Do not allow them to enter the blower.

NOISE - Mount the unit on a solid surface that will not increase the sound. This will reduce noise and vibration. We suggest the use of shock mounts or vibration isolation material for mounting.

ROTATION - The Gast Regenair Blower should only rotate clockwise as viewed from the electric motor side. The casting has an arrow showing the correct direction. Confirm the proper rotation by checking air flow at the IN and OUT ports. If needed reverse rotation of three phase motors by changing the position of any two of the power line wires.

OPERATION

- ⚠ WARNING** Solid or liquid material exiting the blower or piping can cause eye damage or skin cuts. Keep away from air stream.

- ⚠ WARNING** - Gast Manufacturing Corporation will not knowingly specify, design or build any blower for installation in a hazardous, combustible or explosive location without a motor conforming to the proper NEMA or U. L. standards. Blowers with standard TEFC motors should never be utilized for soil vapor extraction applications or where local state and/or Federal codes specify the use of explosion-proof motors (as defined by the National Electric Code, Articles.100,500 c1990).

- ⚠ CAUTION** Attach blower to solid surface before starting to prevent injury or damage from unit movement. Air containing solid particles or liquid must pass through a filter before entering the blower. Blowers must have filters, other accessories and all piping attached before starting. Any foreign material passing through the blower may cause internal damage to the blower.

- ⚠ CAUTION** Outlet piping can burn skin. Guard or limit access. Mark "CAUTION Hot Surface. Can Cause Burns". Air temperature increases when passing through the blower. When run at duties above 50 in. H₂O, metal pipe may be required for hot exhaust air. The blower must not be operated above the limits for continuous duty. Only models R3105N-50, R4110N-50 and R4310P-50 can be operated continuously with no air flowing through the blower. Other units can only be run at the rating shown on the model number label. Do not Close off inlet (for vacuum) to reduce extra air flow. This will cause added heat and motor load. Blower exhaust air in excess of 230°F indicates operation in excess of rating which can cause the blower to fail.

ACCESSORIES ...Gast pressure gauge AJ496 and vacuum gauges AJ497 or AE134 show blower duty. The Gast pressure/vacuum relief valve, AG258, will limit the operating duty by admitting or relieving air. It also allows full flow through the blower when the relief valve closes.

SERVICING

⚠ WARNING To retain their sealed construction they should be serviced by Gast authorized service centers ONLY. These models are sealed at the factory for very low leakage.

⚠ WARNING Turn off electric power before removing blower from service. Be sure rotating parts have stopped. Electric shock or severe cuts can result. Inlet and exhaust filters attached to the blower may need cleaning or replacement of the elements. Failure to do so will result in more pressure drop, reduced air flow and hotter operation of the blower.

The outside of the unit requires cleaning of dust and dirt. The inside of the blower also may need cleaning to remove foreign material coating the impeller and housing. This should be done at a Gast Authorized Service Center. This buildup can cause vibration, failure of the motor to operate or reduced flow.

KEEP THIS INFORMATION WITH THIS BLOWER. REFER TO IT FOR SAFE INSTALLATION, OPERATION OR SERVICE.

MOTOR WIRING DIAGRAM FOR R4110N-50 & R3105N-50

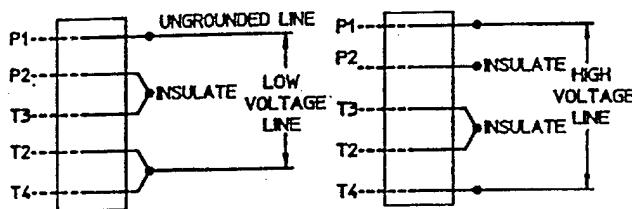

>>* WARNING
THIS MOTOR IS THERMALLY PROTECTED AND WILL AUTOMATICALLY RESTART WHEN PROTECTOR RESETS. ALWAYS DISCONNECT POWER SUPPLY BEFORE SERVICING.

MOTORS WIRING DIAGRAM FOR R4310P-50

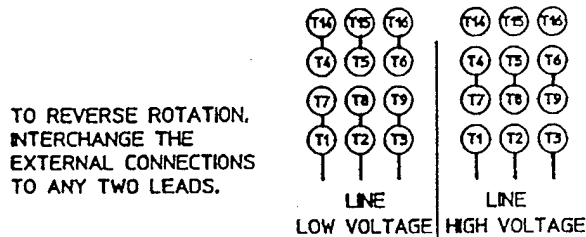

>>* WARNING
THIS MOTOR IS THERMALLY PROTECTED AND WILL AUTOMATICALLY RESTART WHEN PROTECTOR RESETS. ALWAYS DISCONNECT POWER SUPPLY BEFORE SERVICING.

MOTORS WIRING DIAGRAM FOR R5325R-50, R6350R-50, R6P355R-50, & R7100R-50

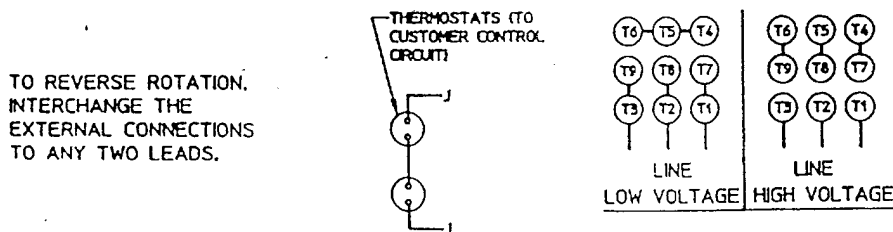

Oilless Regenerative Blowers, Motor Mounted to 92 cfm



REGENAIR® R4 Series

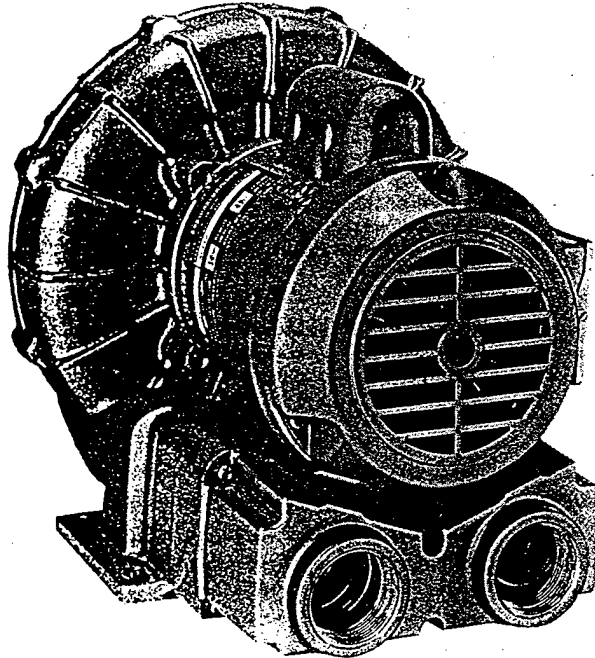

MODEL R4110-2
52" H₂O MAX. PRESSURE, 92 CFM OPEN FLOW

PRODUCT FEATURES

- Oilless operation
- TEFC motor mounted
- Can be mounted in any plane
- Rugged construction/low maintenance
- Can be operated blanked-off

COMMON MOTOR OPTIONS

- 115/208-230V, 60 Hz; 110/220-240V, 50 Hz, single phase
- 208-230/460V, 60 Hz; 190-230/380-415V, 50 Hz, three phase
- 575V, 60 Hz, three phase

RECOMMENDED ACCESSORIES

- Pressure gauge AJ496
- Filter AG338
- Muffler AJ121D
- Relief valve AG258

Various brand name motors are used on any model at the discretion of Gast Mfg. Corp.

Important Notice:

Pictorial and dimensional data is subject to change without notice.

Product Dimensions Metric (mm) U.S. Imperial (inches)

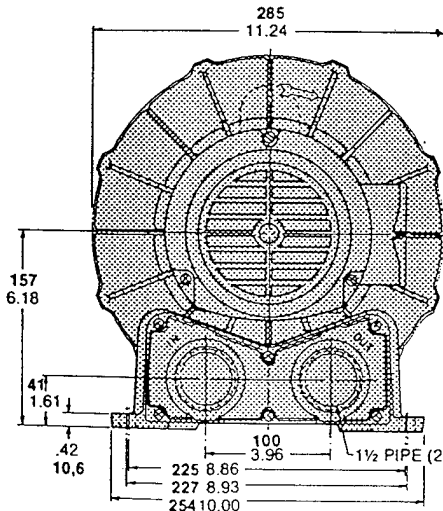
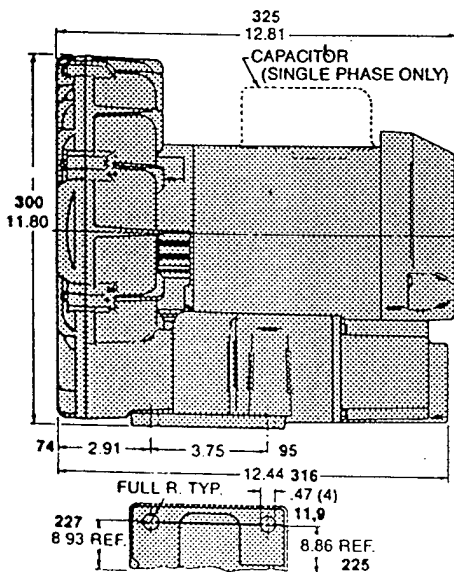

Product Specifications

Model Number	Motor Specs	Full Load Amps	HP	RPM	Max Pressure		Max Flow		Net Wt.	
					"H ₂ O	mbar	cfm	m ³ h	lbs.	kg
R4110-2	110/220-240-50-1	9.0/4.5-5.7	0.6	2850	38	95	74	126	41	18,6
	115/208-230-60-1	9.8/5.2-4.9	1.0	3450	52	130	92	156		
R4310A-2	190-220/380-415-50-3	2.6-3.3/1.3-1.4	0.6	2850	38	95	74	126	41	18,6
	208-230/460-60-3	3.4-3.2/1.6	1.0	3450	52	130	92	156		

Product Performance (Metric U.S. Imperial)

Black line on curve is for 60 cycle performance.
Blue line on curve is for 50 cycle performance.

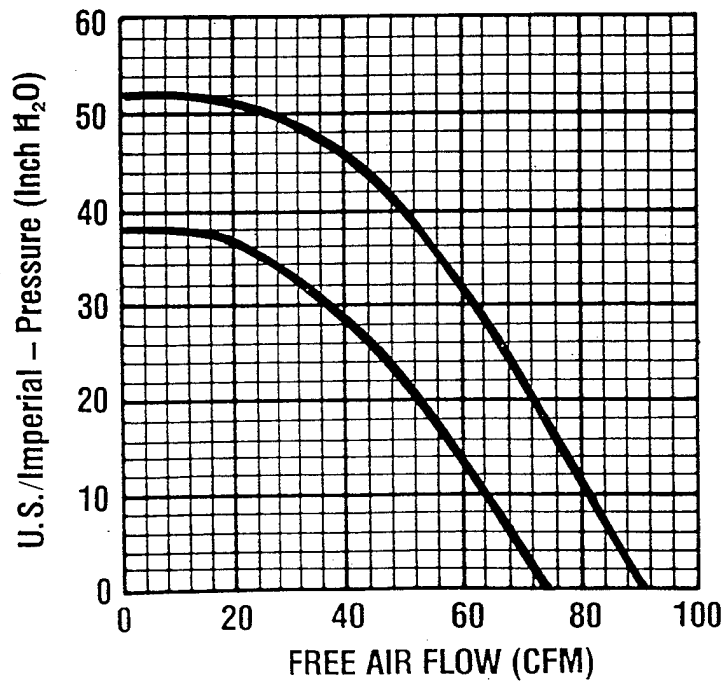
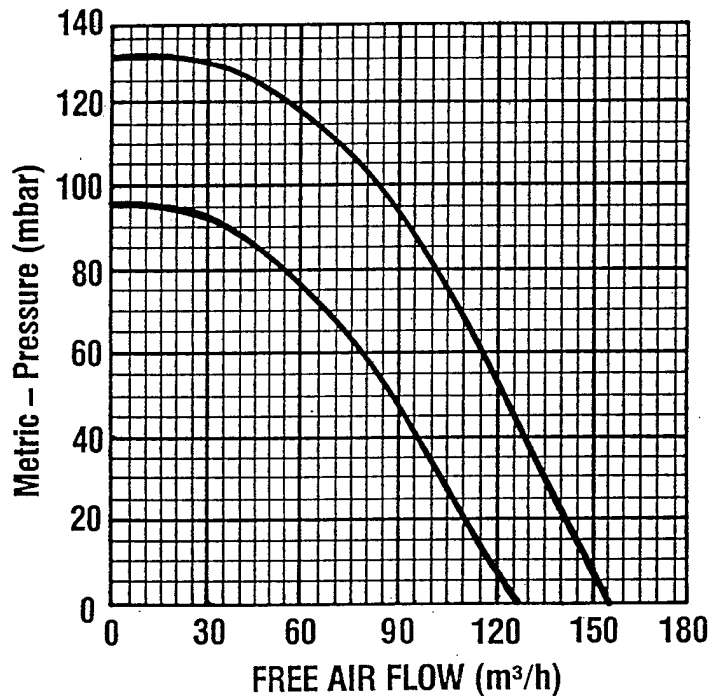



MANUFACTURING CORPORATION

P. O. BOX 97, BENTON HARBOR, MICHIGAN 49022
PHONE 616-926-6171

70-6300
F2-105
6/88

Blower Relief Valve Operating Instructions (AG258)

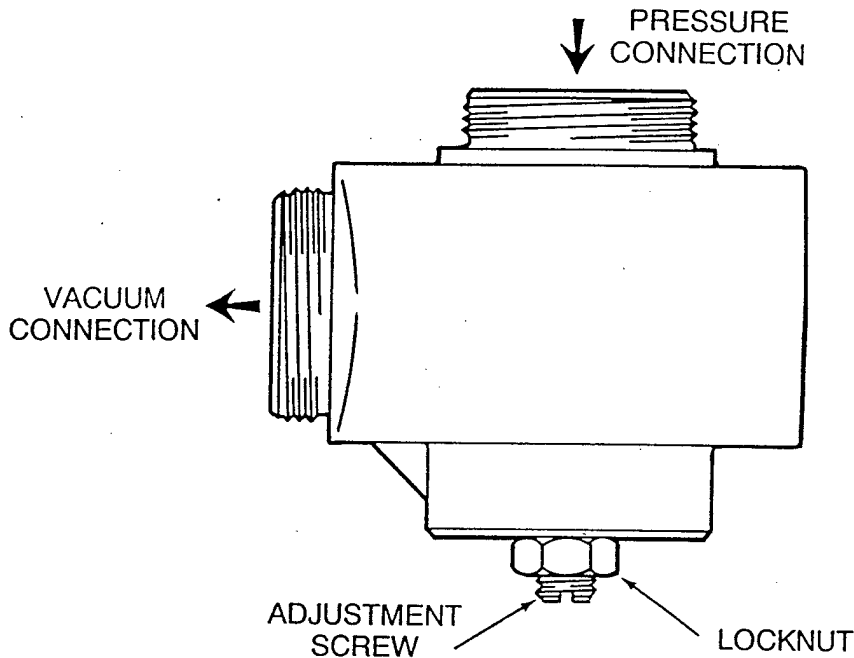

Operating the Regenair Regenerative blowers with more than 1 HP motors and insufficient air flow can result in damage to the blower caused by excessive heating of the air passing through the blower.

The AG258 blower relief valve can be adjusted to limit the pressure and/or vacuum level and maintain adequate air flow through the blower to prevent damage from excessive heat.

The adjusting of the relief valve is accomplished by loosening the lock nut on the adjusting screw and turning the adjusting screw with the blade of a screwdriver. Turning the adjusting screw clockwise will increase the relief valve setting and counter clockwise will decrease the setting. Hold the screwdriver in place when retightening the lock nut. The use of the Gast pressure (AE133) or vacuum (AE134) gauge will provide an accurate setting.

The valve is position sensitive. The recommended installation position is with the adjusting screw positioned vertically down. Final adjustments to change the setting up to 15 inches of water may be made by rotating the valve up to 20 degrees from vertical.

CAUTION: For units with air flows exceeding 200 CFM two relief valves should be used in parallel to provide proper cooling to the blower.

All components of the valve are made of corrosion resistant metal. In normal operation the only maintenance required is cleaning the valve with Gast Flushing Solvent (AH255A). Often the valve need not be disassembled to clean. Particular attention should be given to cleaning the small hole through the center of the piston. If this becomes clogged the valve will not function properly. A pin or small diameter wire may be used to clean the blocked hole.

WARNING: WHEN INSTALLING THE PRESSURE/VACUUM RELIEF VALVE, ALL POWER SOURCES TO THE ELECTRIC MOTOR AND ANY ACCESSORY DEVICES SHOULD BE DISCONNECTED AND ALL ROTATING PARTS SHOULD BE AT A STANDSTILL OR BODILY INJURY COULD RESULT.

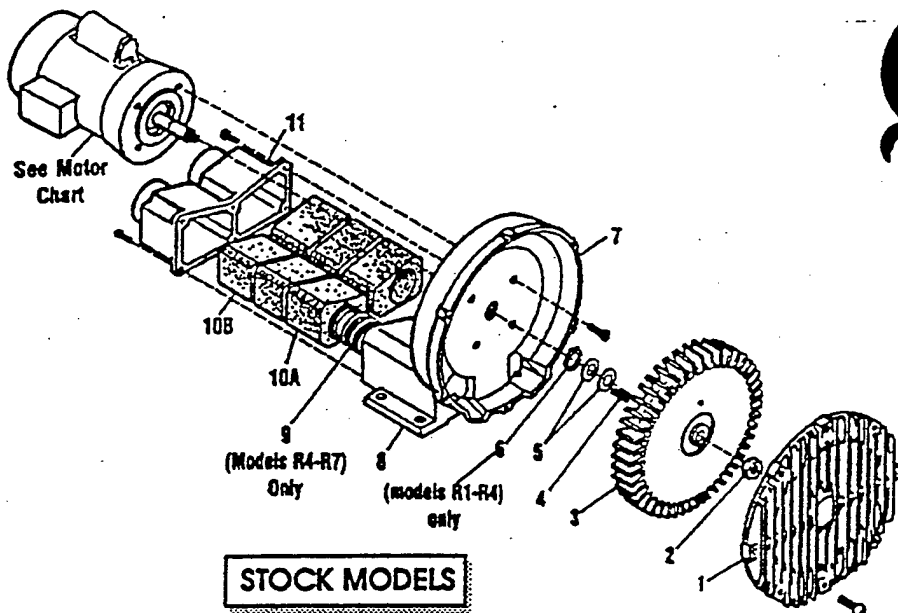

STOCK MODELS

Name	R1	R2	R3	R4	R5	R6	R6P	R6PP/R6PS	R7
Cover	AJ101A	AJ101B	AJ101C	AJ101D	AJ101EQ	AJ101F	AJ101K	(2)AJ101KA	AJ101G
Topnut	BC187	BC187	BC181	BC181	BC181	BC181	BC181	(2)BC182	BC183
Impeller	AJ102A	AJ102BQ	AJ102C	AJ102D	AJ102E	AJ102FR	AJ102K	(2)AJ102KA	AJ102GA
Square Key	AH212C	AH212	AB136A	AB136D	AB136	AB136	AB136	(2)AB136	AC628
Blind Spacer (s)	AJ132	AE686-3	AJ109	AJ109	AJ109	AJ116A	AJ116A	AJ116A	AJ110
Retaining Ring	AJ145	AJ145	AJ149	AJ149					
Housing	AJ103A	AJ103BQ	AJ103C	AJ103DR	AJ103E	AJ103F	AJ103K	AJ103KD	AJ103GA
Muffler Box					AJ104E	AJ104F			
Spring				AJ113DR	AJ113DQ	AJ113FQ	AJ113FQ		AJ113G
Blow Foam	(4)AJ112A	(4)AJ112B	(4)AJ112C	(4)AJ112DS	(4)AJ112ER	(6)AJ112F	(8)AJ112K		(8)AJ112GA
Blow Foam		(2)AJ112BQ	(2)AJ112CQ	(2)AJ112DR	(2)AJ112EQ				
Muffler Extension/ Adapter Plate	AJ106H	AJ106BQ	AJ106CQ	AJ106DQ	AJ106EQ	AJ106FQ	AJ104K		AJ104GA
Kit	K396	K396							K395

MOTOR CHART

GENAIR MODEL NUMBER	MOTOR NUMBER	MOTOR SPECIFICATIONS		PHASE
		60 HZ VOLTS	50 HZ VOLTS	
102	J111X	115/208-230	110/220-240	1
102C	J112X	115		1
103	J311X	115/208-230	110/220	1
105	J411X	115/208-230	110/220	1
103A	J310	208-230/460	220/380-415	3
103F	J313	208-230	220	3
105-1/R3105-12	J411X	115/208-230	110/220-240	1
1305A-1/R3305A-13	J410	208-230/460	220/380-415	3
110-2	J611AX	115/208-230	110/220-240	1
110A-2	J610	208-230/460	220/380-415	3
125-2	J811X	115/208-230		1
125A-2	J810X	208-230/460	220/380-415	3
125-2	J811X	115/208-230		1
125A-2	J810X	208-230/460	220/380-415	3
135A-2	J910X	208-230/460	220/380-415	3
150J-2	J1013	230		1
150A-2	J1010	208-230/460	220/380-415	3
1335A	J910X	208-230/460	220/380-415	3
1350A	J1010	208-230/460	220/380-415	3
1355A	J1110A	208-230/460	220/380-415	3
150A-2	J1210B	208-230/460	220/380-415	3
16PP/R6PS3110M	JD1100	208-230/460	220/380-415	3

* No lubrication needed at start up. Bearings lubricated at factory.

* Motor is equipped with alemite fitting. Clean tip of fitting and apply grease gun. Use 1 to 2 strokes of high quality ball bearing grease.

Consistency	Type	Typical Grease
Medium	Lithium	Shell Dolum R

Hours of service per year	Suggested Re-lube Interval
5,000	3 years
Continual Normal Application	1 year
Seasonal service motor idle for 6 months or more	1 year beginning of season 6 months
Continuous-high ambients, dirty or moist applications.	

60 HZ FLOW DATA (CFM)

All performance figures relate to stock models. A few high pressure units may be available. Consult your local distributor.

Regenair Model Number	P R E S S U R E						Maximum Pressure "H ₂ O"
	0"H ₂ O	20"H ₂ O	40"H ₂ O	60"H ₂ O	80"H ₂ O	100"H ₂ O	
R1	26	14					28
R2	42	26					38
R3105-1	52	38	14				42
R3105-12	52	36	23				55
R3305A-13	52	36	23				55
R4	90	70	50				52
R5	145	130	100				65
R6125-2	200	180					35
R6325A-2	200	180	152				40
R6335A-2	205	175	155	135			70
R6350A-2	200	180	150	130	110	80	105
R6P335A	290	250					30
R6P350A	300	260	230	200			60
R6P355A	300	260	230	200	160		90
R7100A-2	420	380	340	310	280	230	115
R6PP311OM	485	452	420	380	330		95
R6PS311OM	265	258	252	244	236	226	170

Regenair Model Number	V A C U U M					Maximum Vacuum "H ₂ O"
	0"H ₂ O	20"H ₂ O	40"H ₂ O	60"H ₂ O	80"H ₂ O	
R1	25	14				26
R2	40	22				34
R3105-1	50	34	9			40
R3105-12	51	34	20			50
R3305A-13	51	34	20			50
R4	82	62	39			48
R5	140	115	90	50		60
R6125-2	190	155	125			45
R6325A-2	190	155	125			45
R6335A-2	190	150	125	100		75
R6350A-2	190	180	150	100	70	90
R6P335A	270	230				37
R6P350A	280	240	210	170		70
R6P355A	280	240	210	170	100	86
R7100A-2	410	350	300	250	170	90
R6PP311OM	470	425	375	320	220	80
R6PS311OM	240	225	210	195	175	130

***This number indicates the maximum static pressure differential recommended (with cooling air still flowing through unit). In general, units 1hp or less can be dead headed. Check with local representative or distributor to verify which models apply.**

Operation of the blower above the recommended maximum duty will cause premature failure due to the build up of heat damaging the components.

Performance data was determined under the following conditions:

- 1) Unit in a temperature stable condition.
- 2) Test conditions: Inlet air density at 0.075lbs. per cubic foot. (20°C{68°F}, 29.92 in. Hg{14.7PSIA}).
- 3) Normal performance variations on the resistance curve within +/- 10% of supplied data can be expected.
- 4) Specifications subject to change without notice.
- 5) All performance at 60Hz operation.

Accessories for GAST REGENAIR® Blowers

GAUGES – To monitor the system performance so as not to exceed maximum duties. Using two (one on each side of the filter) is a great way to know when the filter needs servicing.

FILTERS – The impeller of a blower passes very close to the housing. It is always wise to have an inlet or in-line filter to ensure troublefree life.

MUFFLERS – Designed to reduce noise by 5-8 dbA and remove high frequency sound associated with all blowers.

RELIEF VALVES – By setting a relief valve at a given pressure/vacuum you can be assured that no harm will come to the blower or products in your application from excessive duties.

FITTINGS – Gast has a complete line of male hose bars, tees, common elbows and close nipples for easy hook-up.

HORIZONTAL SWING TYPE CHECK VALVE – Designed to prevent back-wash of fluids that would enter the blower. Also prevents air back-streaming if needed. They can be mounted with their discharge either vertical or horizontal. Valve will open with 3" of water pressure.

In-line Filters (for vacuum)

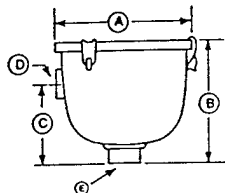

Model No.	R1	R2	R3	R4	SDR4, R5	SDR5, SDR6, R6, R6P	SDR6P, R6PP, R6PS, R7
Part No.	AJ151A	AJ151B	AJ151C	AJ151D	AJ151E	AJ151G	AJ151H
Dim. A	5.93"	7.38"	7.38"	7.38"	8.75"	8.00"	14.00"
Dim. B	4.50"	6.81"	6.81"	6.81"	10.25"	10.25"	26.50"
Dim. C	2.75"	4.62"	4.62"	4.62"	5.00"	5.50"	18.13"
Dim. D	1" FPT	1" FPT	1¼" FPT	1½" FPT	2" FPT	2½" FPT	3" MPT
Dim. E	1" FPT	1" FPT	1¼" FPT	1½" FPT	2" FPT	2½" FPT	3" MPT
Replacement Element	AJ135D	AJ135E	AJ135E	AJ135E	AJ135F	AJ135G	AJ135C
Micron	10	10	10	10	10	10	10

MPT = Male Pipe Thread
FPT = Female Pipe Thread

Inlet Filters (for pressure units only)

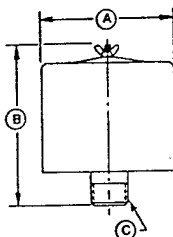

Model No.	R1 & R2	R3	R4, R5 & SDR4	SDR5, R6, SDR6, R6P	R6PP, R6PS, SDR6P, R7
Part No.	AJ126B	AJ126C	AJ126D	AJ126F	AJ126G
Dim. A	6.00"	6.00"	7.70"	10.63"	10.00"
Dim. B	4.62"	7.12"	7.25"	4.81"	13.12"
Dim. C	1" MPT	1¼" MPT	1½" MPT	2" FPT	2½" MPT
Replacement Element	AJ134B	AJ134C	AJ134E	AG340	AJ135A
Micron	10	10	10	25	10

MPT = Male Pipe Thread
FPT = Female Pipe Thread
All are heavy-duty for high amounts of particulates.
Inlet filters for REGENAIR® blowers are drip-proof when mounted as shown.

Mufflers

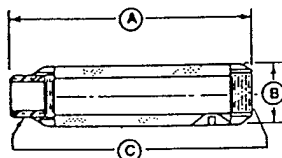

Model No.	R1 & R2	R3	R4, R5, SDR4, SDR5	R6, SDR6P, SDR6, R6P, R6PP, R6PS	R7
Part No.	AJ121B	AJ121C	AJ121D	AJ121F	AJ121G
Dim. A	7.46"	7.94"	12.75"	17.44"	17.44"
Dim. B	2.38"	2.62"	3.25"	3.63"	4.25"
Dim. C	1" NPT	1¼" NPT	1½" NPT	2" NPT	2½" NPT

Horizontal Swing Type Check Valve

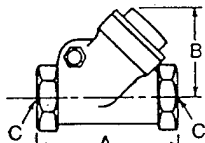

Model No.	R1 & R2	R3	R4, R5, SDR4 & SDR5	R6, R6P, R6PP, R6PS, SDR6 & SDR6P	R7
Part No.	AH326B	AH326C	AH326D	AH326F	AH326G
Dim. A	3.57	4.19	4.50	5.25	8
Dim. B	2.32	2.69	2.94	3.82	5.07
Dim. C	1" NPT	1¼" NPT	1½" NPT	2" NPT	2½" NPT

Fittings

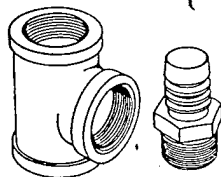

Pipe Size	1"	1¼"	1½"	2"	2½"
Tee	BA415	BA431	BA432	BA433	BA434
Common Elbow	BA220	BA244	BA230	BA247	BA248
Nipple	BA752	BA809	BA783	BA810	BA813
Plastic Male Pipe Hose Barb	AJ117A	AJ117B	-	-	-
Hose I.D.	1.25	1.25	-	-	-
Metal Male Pipe Hose Barb	AJ117D	AJ117F	AJ117C	AJ117G	AJ117H
Hose I.D.	1.00	1.25	1.50	2.50	3.00

Relief Valve

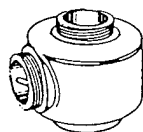

- Pressure/Vacuum Relief Valve, 1½" NPT, Adjustable 30 – 170 in. H₂O, 200 cfm max.
Part #AG258
- Silencer for Relief Valve
Part #AJ121D

Pressure-Vacuum Gauge



- Pressure Gauge, Part #AJ496, 2½" Dia., ¼" NPT, 0-60 in. H₂O and 0-150 mbar
- Pressure Gauge, Part #AE133, 2½" Dia., ¼" NPT, 0-160 in. H₂O and 0-400 mbar
- Pressure Gauge, Part #AE133A, 2½" Dia., ¼" NPT, 0-200 in. H₂O
- Vacuum Gauge, Part #AJ497, 2½" Dia., ¼" NPT, 0-60 in. H₂O and 0-150 mbar
- Vacuum Gauge, Part #AE134, 2½" Dia., ¼" NPT, 0-160 in. H₂O and 0-400 mbar

ATTACHMENT B

APPENDIX B

GEOLOGIC LOGS AND CHAIN OF CUSTODY FORMS

Blows/6"	TVH (ppm)	ID#/Recov	DEPTH (ft)	SAMPLES	SYMBOLS	MATERIALS DESCRIPTION
3/6/7	8	70%	5			Poorly Graded SAND to SILTY SAND (SM): olive brown (2.5 Y 4/4); medium to fine grained, no plasticity; moist, no odor.
8/6/20	8	90%	10			Lean CLAY (CL): dark grayish brown (2.5 Y 4/2); medium toughness, high plasticity; dry to moist, no odor. SILTY SAND (SM): as above.
16/30/60	1,000	VA2-VW-15 95%	15			Lean CLAY (CL): light brownish gray (2.5 Y 6/2); medium to high toughness, high plasticity; no odor. Same as above, except light olive brown (2.5 Y 5/4). <u>Beginning to smell hydrocarbons from borehole.</u>
24/26/37			20			Poorly Graded SAND (SP): light brownish gray (2.5 Y 6/2); fine to medium grained, no plasticity, little silt; <u>strong hydrocarbon odor.</u> Same as above.
21/26/37	140	15%	25			Grading to a SILTY SAND (SM): light brownish gray (2.5 Y 6/2); fine grained, low plasticity; no staining, <u>strong hydrocarbon odor.</u>
14/20/27	54	95%	30			CLAYEY SAND (SC) to SANDY LEAN CLAY (CL): light brownish gray (2.5 Y 6/2); fine grained, medium plasticity, some gravel in places; moist, no staining, <u>strong odor.</u>
14/20/24	400	90%	35			SANDY CLAY (CL): pale olive (5 Y 6/4); coarse to fine grained sand, medium plasticity, coarse sand is Chert; moist, no staining, <u>hydrocarbon odor.</u>
21/28/40	1,000	100%	40			CLAYEY SAND (SC): dark bluish gray (5 B 4/1); coarse to fine grained, low plasticity.
30/40/48	94	100%	45			Same as above, except medium to fine grained.
25/45/ 55-5.5"	15	100%	50			Same as above.
12/18/24	22	100%	55			SILTY SAND to SANDY SILT (SM): greenish gray (5 BG 5/1); fine grained, no plasticity.
33/50-5"	14	50%	60			SILTY SAND (SM): dark greenish gray (5 G 4/1); coarse to fine, no plasticity; moist, <u>slight to no odor.</u>
15/26/40	42	95%	65			CLAYEY SAND (SC) with Gravel: dark greenish gray (5 G 4/1); coarse to fine, no plasticity; moist, <u>slight to no odor.</u>
28/50-6"	24	50%	70			Poorly Graded SAND (SP): greenish gray (5 GY 5/1); medium and fine grained, no plasticity; no odor.
50-5"			75			Total Depth = 74.0' bgs. Bedrock - Chert.

PROJECT	Vandenberg Air Force Base	DRILLING COMPANY	Tonto Environmental Services
LOCATION	Corner of 13th and New Mexico, Site 6454	DATE DRILLED	02/22/94
JOB NUMBER	722406.22040	SURFACE ELEVATION	
GEOLOGIST	Chris Pluhar/Tom Blaney	TOTAL DEPTH OF HOLE	74 Feet
DRILL RIG	Hollow Stem Auger	WATER LEVEL	

Blows/6"	TVH (ppm)	ID#/Recov	DEPTH (ft)	SAMPLES	SYMBOLS	MATERIALS DESCRIPTION
						SAND (SP): dark brown (5 YR 3/2); fine to medium grained, some well rounded pebbles, some cobbles; moist.
2/2/5	0	75%	5			CLAYEY SAND (SC): pinkish gray (7.5 YR 6/2) with iron staining; fine grained, medium plasticity; dry.
50-6"	0	30%	10			SAND (SP): pinkish gray (7.5 YR 6/2); iron cemented, fine to medium grained, no plasticity.
6/26/50	6,500	100%	15			SAND (SP): light reddish brown (2.5 Y 6/3); fine to medium grained, no plasticity; moist, <u>strong hydrocarbon odor</u> .
26/50-5"	>10,000	75%	20			Same as above.
21/26/30	20	100%	25			CLAYEY SAND (SC): brownish yellow (10 YR 6/8); fine to medium grained, low plasticity.
31/30/36	---	VA2-MPA-30 100%	30			CLAYEY SAND (SC): brownish yellow (10 YR 6/8); fine grained, low plasticity; grades into clayey gravel.
						CLAYEY SAND (SC): light gray (7.5 YR 7/0) with some iron staining; low plasticity.
27/28/32	30	90%	35			CLAYEY SAND (SC): light gray (7.5 YR 7/0), no iron staining; low plasticity, some larger, angular particles.
						Same as above.
						SAND (SP): light gray (7.5 YR 7/0); fine grained, well sorted; dry.
22/50-6"	3	80%	40			CLAYEY SAND (SC): fine to coarse grained.
						CLAYEY SAND (SC): light gray (7.5 YR 7/0); fine to coarse grained, no plasticity; dry.
18/26/34	5	75%	45			SAND (SP): gray (10 YR 6/1); fine to medium grained, well sorted; dry.
25/60-6"	2	67%	50			Same as above.
						Same as above.
23/31/40	3	50%	55			CLAYEY SAND (SC): light gray (7.5 YR 7/0); fine to coarse grained, low plasticity; dry.
						SAND (SP): gray (10 YR 6/1); fine grained, well sorted; moist.
						SAND (SP): gray (10 YR 6/1); fine to coarse grained; dry.
33/31/ 50-3"	---	---	60			Same as above.
						Total Depth = 61.0' bgs.
			65			

PROJECT	Vandenberg Air Force Base	DRILLING COMPANY	Tonto Environmental Services
LOCATION	Corner of 13th and New Mexico, Site 6454	DATE DRILLED	02/23/94
JOB NUMBER	722406.22040	SURFACE ELEVATION	
GEOLOGIST	Chris Pluhar/Tom Blaney	TOTAL DEPTH OF HOLE	61 Feet
DRILL RIG	Hollow Stem Auger	WATER LEVEL	

Blows/6"	TVH (ppm)	ID#/Recov	DEPTH (ft)	SAMPLES	SYMBOLS	MATERIALS DESCRIPTION
			5			SILTY SAND (SM): dark grayish brown (10 YR 4/2); some organics, no odor.
8/9/8			5			SANDY CLAY (CL): very dark grayish brown (10 YR 3/2); some organics, no odor.
21/32/34	0	100%	10			CLAYEY SAND (SC): light brownish gray (10 YR 6/2) with iron staining (10 YR 5/6); no plasticity.
27/50-6"	6500	75%	15			SAND (SP): gray (10 YR 6/1); fine to medium grained; dry, <u>strong hydrocarbon odor</u> .
26/40/55	>10,000	90%	20			Same as above.
17/21/30	34	100%	25			SANDY CLAY (CL): light brownish gray (10 YR 6/2); fine to coarse grained, grading into clay (see below). Fatty CLAY (CH): light gray (10 YR 7/2).
20/50-6"	4	100%	30			Same as above. GRAVELLY CLAY (CL): light gray (10 YR 7/2); broken fragments of chert and shale; <u>slight hydrocarbon odor</u> .
27/31/40	380	100%	35			Same as above.
21/30/36	4400	100%	40			CLAYEY SAND (SC): light gray (10 YR 7/2); fine to coarse grained, no plasticity, smaller chert and shale fragments; <u>strong hydrocarbon odor</u> .
20/23/32	4000	100%	45			Same as above.
10/25/50	8000	100%	50			Same as above.
15/24/30	600	100%	55			SAND (SP): pale olive (5 Y 6/2); fine to coarse grained; moist, <u>medium product odor</u> .
			60			
			65			CLAYEY SAND (SC): fine to coarse grained.
						Total Depth = 63.0' bgs.

VA2-MPB-62

PROJECT	Vandenberg Air Force Base	DRILLING COMPANY	Tonto Environmental Services
LOCATION	Corner of 13th and New Mexico, Site 6454	DATE DRILLED	02/24/94
JOB NUMBER	722406.22040	SURFACE ELEVATION	
GEOLOGIST	Chris Pluhar/Tom Blaney	TOTAL DEPTH OF HOLE	63 Feet
DRILL RIG	Hollow Stem Auger	WATER LEVEL	

Blows/6"	TVH (ppm)	ID#/Recov	DEPTH (ft)	SAMPLES	SYMBOLS	MATERIALS DESCRIPTION
						SILTY SAND (SM): dark grayish brown (10 YR 4/2); some organics, no odor.
6/8/5		100%	5			Same as above, grading into a Sandy Clay at ~6.5' bgs.
50-6"		25%	10			CLAY (CL): very dark grayish brown (10 YR 3/2); some organics, no odor.
45/50-2"	5400	30%	15			SAND (SP): gray (10 YR 6/1); fine to coarse grained; <u>slight product odor</u> .
50-6"	>10,000	35%	20			SAND (SP): gray (10 YR 6/1); well sorted; <u>strong product odor</u> .
						Same as above.
12/15/20	62	100%	25			SANDY CLAY (CL): light olive gray (5 Y 6/2); grading from coarse to fine particles at 26', low to medium plasticity.
26/50-6"		100%	30			SANDY CLAY (CL): fine particles, medium plasticity; <u>very slight product odor</u> .
						SANDY CLAY (CL): light brownish gray (2.5 Y 6/2); fine to very coarse grained; no odor.
34/50-6"	400	75%	35			SAND (SP): gray (10 YR 6/1); well sorted; <u>medium to strong product odor</u> .
13/17/20	>10,000	100%	40			SILTY SAND (SM): gray (10 YR 6/1); well sorted; moist, <u>stronger product odor than above</u> .
21/50-4"	200	75%	45			SAND (SP): gray (10 YR 6/1); fine to coarse grained; moist, <u>medium product odor</u> .
34-6"	30	50%	50			CLAYEY SAND (SC): light brownish gray (10 YR 6/2), with some oxidation (7.5 YR 6/8); fine to coarse grained - larger particles are chert; low plasticity; dry.
14/60-6"	20	40%	55			Same as above.
55-6"	10	15%	60			Same as above, except more oxidation.
			65			Total Depth = 63.0' bgs.

PROJECT	Vandenberg Air Force Base	DRILLING COMPANY	Tonto Environmental Services
LOCATION	Corner of 13th and New Mexico, Site 6454	DATE DRILLED	02/25/94
JOB NUMBER	722406.22040	SURFACE ELEVATION	
GEOLOGIST	Chris Pluhar/Tom Blaney	TOTAL DEPTH OF HOLE	63 Feet
DRILL RIG	Hollow Stem Auger	WATER LEVEL	



AIR TOXICS LTD.
AN ENVIRONMENTAL ANALYTICAL LABORATORY

180 BLUE RAVINE ROAD, SUITE B
FOLSOM, CA 95630
(916) 985-1000 • FAX (916) 985-1020

CHAIN OF CUSTODY RECORD

Page of

PROJECT # 722406 22046 PO #

COLLECTED BY (Signature)

REMARKS

FIELD SAMPLE I.D.#	SAMPLING MEDIA (Tenax, Canister etc.)	DATE/TIME	ANALYSIS	VAC./PRESSURE	LAB I.D.#
VAZ-MPB-20'	Canister	2/28/94	EPA METHOD TO-3		
VAZ-MPE-10'	"	2/28/94	EPA METHOD TO-3		
VAZ-MPC-60'	"	2/28/94	EPA METHOD TO-3		

RELINQUISHED BY: DATE/TIME 709 PBL 2/28/94 1545 RECEIVED BY: DATE/TIME
FED EX AIR BILL 601 7737261 2/28/94 1545 RELINQUISHED BY: DATE/TIME RECEIVED BY: DATE/TIME

LAB USE ONLY

SHIPPER NAME AIR BILL # OPENED BY: DATE/TIME TEMP (°C) CONDITION

REMARKS

