



SPAWAR
Systems Center
San Diego

TECHNICAL REPORT 1836
September 2000

COMWIN Antenna System Fiscal Year 2000 Report

R. C. Adams
R. S. Abramo
J. L. Parra
J. F. Moore

Approved for public release;
distribution is unlimited.

SSC San Diego

TECHNICAL REPORT 1836
September 2000

COMWIN Antenna System Fiscal Year 2000 Report

R. C. Adams
R. S. Abramo
J. L. Parra
J. F. Moore

Approved for public release;
distribution is unlimited.



*SPAWAR
Systems Center
San Diego*

SSC San Diego
San Diego, CA 92152-5001

20001130 058

SSC SAN DIEGO
San Diego, California 92152-5001

Ernest L. Valdes, CAPT, USN
Commanding Officer

R. C. Kolb
Executive Director

ADMINISTRATIVE INFORMATION

The work described in this report was performed for the Expeditionary Warfare Division of the Office of Naval Research (ONR 353) and the Command and Control Project Officer (ONR 31) by the SSC San Diego Signal Processing & Communication Technology Branch (D855).

Released by
C. R. Hendrickson, Head
Signal Processing & Communication
Technology Branch

Under authority of
C. J. Sayre, Head
Electromagnetics &
Advanced Technology
Division

ACKNOWLEDGMENTS

We have the pleasure to acknowledge the assistance of Greg Adams, the business manager of D85. Among other things, he provided access without charge to the West Tower and the Anechoic Chamber. The measurement of the antenna parameters would have been difficult without his help. Dr. John Meloling (D851) provided access to the Hewlett Packard network analyzer for the measurement of impedance. Jim Birkett (D856) provided the signal generator, a shed to conduct the radiation hazard experiments, and much advice and expertise. Clark Hendrickson, the Branch Head of D855, provided much equipment and encouragement. Kianoush Rouzbehani (D851) used the EIGER code to predict the heating of jell and other fluids by the Mark I vest antenna. The New Professional, Ming Kwong, helped during the assessment of radiation hazards. CDR C. Peter Haglind (Swedish Navy), CWO3 Frank Canez, and LCDR Charles Wrightson provided very significant assistance in their roles as heads of the COMWIN Project.

We would also like to thank Professor Jovan Lebaric and Professor Richard Adler of the Naval Postgraduate School (NPS). The concept of the COMWIN System was originated and developed by NPS and their students.

EXECUTIVE SUMMARY

The project to develop a broadband, man-carried antenna began in May 1999. There were two objectives. The first objective was to develop an antenna system whose visual signature did not distinguish the radio operator from any other soldier. The solution to this first objective was to integrate the antenna into the uniform of the soldier. Hence, the project is called COMbat Wear Integration (COMWIN). The second objective was to fabricate an antenna that could transmit or receive at any frequency between 2 MHz and 2 GHz. The Joint Tactical Radio (JTR) requires this frequency coverage. The figure of merit to determine whether the radio is efficient in the band is a Voltage Standing Wave Ratio (VSWR) of less than 3:1. The COMWIN antenna system would consist of three antennas. The first antenna, in the form of a vest, would operate in the 30- to 500-MHz band. The helmet antenna would operate in the 500- to 2000-MHz band. An antenna that runs down the sides of trousers would operate in the 2- to 30-MHz band.

During FY 1999, the vest antenna was designed, fabricated, and tested. By using a 2:1 Radio Frequency (RF) transformer, the VSWR of the COMWIN vest antenna was measured to be less than 3:1 for all frequencies between 100 and 500 MHz. The vest antenna (designated the Mark I) was very inefficient for frequencies less than 100 MHz because of the large mismatch of impedance. The Mark I has a gap between the upper and lower portions that is horizontal (straight gap). Work performed by Professor Lebaric and his colleagues at the Naval Postgraduate School (NPS) indicated that using a saw-toothed gap would cause the performance of the vest antenna to improve in the frequency band between 30 and 100 MHz. Several versions of the saw-toothed gap (Mark II) vest antenna were fabricated at both the NPS and at SPAWAR Systems Center, San Diego (SSC San Diego).

Similarly, two versions of the Helmet Antenna were fabricated at NPS and SSC San Diego. They were designated the Mark I and Mark II helmet antennas, respectively. Both the Mark II vest and the Mark I and Mark II helmets were tested extensively at SSC San Diego. The tests conducted included impedance, gain, and radiation patterns. Measurements of the impedance permitted the assessment of the effects of the flak jacket, the wearer, and the feed mechanism.

The final type of test conducted at SSC San Diego was to assess the radiation hazard of the helmet and vest antennas. Electric and magnetic fields were measured in all the antennas as a function of location, frequency, and power level. The Mark I vest antenna was modified so that power levels as large as 50 W could be input. The heating of known amounts of saltwater (2.2% by weight of salt) and a substance designed to simulate the dielectric and conductive properties of a person was measured.

One of the test results was that the VSWR of the Mark II vest antenna was less than 3:1 for frequencies between 40 and 60 MHz and most frequencies between 100 and 500 MHz. The electrical properties of the wearer have a significant impact upon the impedance of the antenna. The antenna becomes more efficient at frequencies less than 100 MHz if worn by a person. Putting the flak jacket between the antenna and the wearer lessens the improvement. The gain at boresight of the Mark II antenna is greater than 0 dBi for almost all frequencies greater than 90 MHz. The maximum gain is often at the higher elevation angles. The azimuth radiation patterns for frequencies less than 225 MHz were nearly isotropic. For higher frequencies, there were nulls corresponding to the location of the sleeves. The polarization was vertical for all frequencies larger than 80 MHz.

The Mark I (fabricated by NPS and having a straight gap) and the Mark II (fabricated by SSC San Diego and having a saw-toothed gap) helmet antennas were compared. Although the Mark II had a consistently better VSWR over a frequency range of 300 to 2000 MHz, the Mark I had a much

better gain at boresight for all frequencies. The gain for the Mark I helmet antenna was greater than 0 dBi for almost all frequencies higher than 800 MHz. The polarization was vertical for all frequencies. The azimuth radiation pattern for the Mark I and Mark II helmet antennas displayed nulls at all frequencies. At frequencies between 300 and 600 MHz, the radiation patterns were in the form of a cloverleaf.

In assessing the radiation hazard of the COMWIN antenna system, the electric fields were measured as a function of frequency, location, and power level. The electric field was determined to be proportional to the square root of the input power, a result expected on physical grounds. A figure of merit was that the electric field scaled to an input power of 4 W must be less than the Maximum Permissible Exposure (MPE often expressed as an electric field, 61.4 V/m). The configurations used were as follows: (1) Mark I vest, (2) Mark II vest, (3) Mark II vest over the flak jacket, and (4) Mark II vest over the flak jacket over the Mark I vest acting as an electromagnetic shield. The Mark I vest for an input power of 4 W satisfied the MPE for all locations and frequencies above 100 MHz. The Mark II vest, either alone or with the flak jacket, had a scaled electric field larger than the MPE for a narrow set of frequencies near 300 MHz and one location (bottom of vest). The effect of the flak jacket was to reduce the electric field from 140 V/m to 110 V/m. The effect of the Mark I acting as an electromagnetic shield was to reduce the electric field to small values for all frequencies larger than 100 MHz. For all configurations, the scaled electric field at a frequency of 90 MHz was larger than the MPE. There is clearly a resonance at this frequency. Further investigation is warranted.

The measurement of the electric fields with an empty vest is an overestimate. The dielectric and conductive properties of a body affect the distribution of fields. The conductivity often reduces the fields. At frequencies between 250 and 350 MHz, a power of 50 W was input to the Mark I vest covering 34 kg of saltwater (2.2% by weight) for periods of more than 30 minutes. No rise in temperature was measured within the resolution of the temperature sensor (0.1°C). On one occasion, 30 minutes of application of high power to 34 kg of jell led to a rise in temperature of 0.4°C. On four other occasions, no temperature rise was measured. Further research will be done to resolve the discrepancy, which is probably caused by the difference in ambient temperature.

The measurements for which there was no temperature rise indicate that the antenna has a low potential for radiation hazard. The one measurement that had a 0.4 °C temperature rise would indicate a specific absorption rate of 0.8 W/kg, which is a factor of 2 higher than that permitted.

Further research is warranted. The next model of the vest and helmet antennas should be a slightly modified Mark I. In almost all cases, the straight gap has better impedance and radiation patterns compared to a saw-toothed gap. The radiation hazards are more easily mitigated for this version as well. The next phase should also be directed towards practical concerns such as integrating the antenna with flak jacket and feed location. The nulls of the patterns must be mitigated over a broad band. Each will be dealt with by later designs.

CONTENTS

EXECUTIVE SUMMARY	iii
INTRODUCTION.....	1
MARK II COMWIN VEST	3
FABRICATION	4
IMPEDANCE	5
AZIMUTH PATTERNS	10
GAIN.....	13
POLARIZATION	14
ELEVATION PATTERNS	14
CONCLUSIONS CONCERNING CHARACTERISTICS OF MARK II VEST AS AN ANTENNA	17
COMWIN MARK I HELMET ANTENNA.....	19
IMPEDANCE	19
GAIN.....	20
POLARIZATION	20
AZIMUTH PATTERNS	21
ELEVATION PATTERNS	24
COMWIN MARK II HELMET ANTENNA.....	27
FABRICATION	27
IMPEDANCE	28
AZIMUTH PATTERNS	29
CONCLUSIONS ON MARK I AND MARK II HELMET ANTENNAS	31
RADIATION HAZARD ASSESSMENT ON COMWIN ANTENNAS.....	33
GOALS	33
ELECTRIC AND MAGNETIC FIELD MEASUREMENTS.....	34
Vest Antennas	34
Helmet Antennas.....	42
SPECIFIC ABSORPTION RATE DETERMINATION	44
Jell Fabrication	46
Results	47
THEORY.....	48
Models.....	49
Comparison of Theory and Experiment.....	49
ANALYSIS	51
CONCLUSIONS.....	53
REFERENCES.....	55

Figures

1. Effect of a person on COMWIN Mark I vest antenna impedance	4
2. Front and rear views of COMWIN Mark II vest antenna.....	5
3. Comparison of impedance of closed-side and open-side versions of NPS vest antennas ...	6
4. Comparison of impedance of upper feed and lower feed of NPS vest antennas	6
5. Comparison of SSC San Diego Mark I and Mark II vest antenna impedance.....	7
6. Comparison of Mark I and Mark II vest antenna impedance after introduction of RF transformer	8
7. Effect of a person on Mark II vest antenna impedance	9
8. Effect of flak jacket on Mark II vest antenna impedance	10
9. Radiation patterns in the horizontal plane for Mark II vest antenna for frequencies between 125 and 400 MHz in steps of 25 MHz	11
10. Boresight gain versus frequency for Mark II vest antenna.....	13
11. Difference of boresight gain between vertical and horizontal polarizations versus frequency for Mark II vest antenna	14
12. Radiation patterns versus elevation angle for frequencies between 125 and 400 MHz	15
13. VSWR versus frequency for NPS COMWIN Mark I helmet antenna	19
14. Boresight gain of Mark I and Mark II helmet antennas versus frequency	20
15. Difference in vertical gain at boresight with horizontal gain as a function of frequency for Mark I helmet antenna	21
16. Radiation patterns in horizontal plane versus frequency for Mark I helmet antenna	22
17. Signal relative to signal at boresight versus elevation angle and frequency for Mark I helmet antenna	25
18. Mark I helmet antenna (side view) and Mark II helmet antenna (front view)	27
19. Mark II helmet antenna VSWR versus frequency for three conditions	28
20. Comparison of Mark I and Mark II helmet antenna VSWR versus frequency.....	29
21. Radiation patterns of Mark II helmet antenna versus azimuth and frequency	30
22. Location of measurement sites relative to vest antenna.....	35
23. Comparison of electric fields measured near feed for Mark I vest antenna for two values of input power	36
24. Scaled electric fields measured in Mark I vest antenna at one frequency at one location as a function of input power.....	37
25. Electric fields measured at locations inside and outside Mark I vest antenna as a function of frequency	38
26. Electric fields measured inside Mark I vest antenna versus frequency for 4-W input power.....	40
27. Electric fields measured inside Mark II vest antenna over flak jacket for four locations versus frequency	41
28. Electric fields measured inside Mark II vest antenna for four locations versus frequency....	41
29. Electric fields measured inside Mark II vest antenna over flak jacket over Mark I versus frequency.....	42
30. Electric field scaled to 20-dBm input power measured in Mark I helmet antenna versus frequency	43
31. Electric field scaled to 20-dBm input power measured in Mark II helmet antenna versus frequency	43
32. VSWR versus frequency for Mark I vest antenna surrounding a saltwater solution	45
33. Comparison of VSWR and Mark I vest antenna impedance surrounding jell and a person	48
34. Predicted and measured electromagnetic fields inside Mark I vest antenna as a function of frequency.....	50

35. Predicted ratio of fields in air to those in saltwater.....50

Tables

1. Dielectric and conductive properties of jell with compositions that depend on frequency.....46

INTRODUCTION

Most man-carried antennas have two disadvantages. First, they have a distinctive visual signature that uniquely identifies the radio operator and the officer nearby. This signature makes the officer vulnerable to sniper fire not directed at other members of the squad. Because disruption of command, communications, and control is a frequent goal of snipers, reduction of the signature would make the entire squad less vulnerable. The second disadvantage is that the antenna is specialized to one radio and often very narrow band. By narrow band, we mean that the antenna has efficient operation only over no more than three times the lowest frequency.

The Joint Tactical Radio (JTR) provides an opportunity and a challenge to develop a new antenna for the dismounted marine and soldier. This new radio is extremely broadband. The nominal operating frequencies are between 2 and 2000 MHz. Such a broad band provides a great challenge to any antenna system. The radio also provides an opportunity to develop innovative techniques to reduce the visual signature of the radio operator and to develop a truly broadband antenna.

Every man-carried antenna must meet certain standards. An antenna must meet the requirements of the legacy antennas they are designed to replace. Three of these requirements deal with polarization, angular coverage, and efficiency. The antenna must radiate energy that is vertically polarized at least at the horizon. Such a requirement is dictated by the close association that marines have with naval surface ships whose antennas are vertically polarized because of the preferential way in which such radiation propagates over the ocean. This requirement applies to the circumstance that the radio operator is standing vertically. The second requirement is that the antenna must have omnidirectional coverage in the horizontal plane. This requirement allows the radio operator to communicate with any other similar radio without prior knowledge of the location. The third requirement relates to the Voltage Standing Wave Ratio (VSWR) and gain. If the VSWR is greater than a certain number (the requirement for the Single Channel Ground and Airborne Radio System [SINCGARS] is 3.5:1) a large amount of energy is reflected back to the transmitter and not radiated. Such a circumstance greatly decreases the efficiency and the range of the radio. We have adopted a figure of merit of 3:1 as a goal. This figure of merit implies that three quarters of the power is available for antenna transmission. Antenna gain should be larger than 0 dBi at all angles at the horizon.

The most important requirement is that the antenna must be safe to use. Assessment of the radiation hazard and the amount of energy that reaches the body of the radio operator is a vital part of the effort during Fiscal Year (FY) 2000. The Institute of Electronics and Electrical Engineers (IEEE), the Department of Defense, and the U.S. Navy all agree on the standards for radiation hazard for people who have knowledge that they are in regions of potential danger (so-called controlled areas). One of the ways in which these standards are written is the root-mean-square electric and magnetic fields for frequencies less than 300 MHz and the power density (energy per unit time per unit area) for larger frequencies. Another way is the specific absorption rate (the amount of power per unit mass). The standards are derived from experiments and theory that predict the temperature rise in a body caused by the operation of radio equipment. A 1°C rise in body temperature can be tolerated for an indefinite period of time. An exposure to electromagnetic fields that cause a larger temperature rise is considered unacceptable. There are standards for exposure of the entire body and small volumes (Institute of Electronics and Electrical Engineers, 1992; Department of Defense, 1995; Department of the Navy, 1999).

A combination of the innovation from the academic community and the practical experience of a U.S. Navy laboratory has resulted in merging the antenna with the uniform. Professors Jovan Lebaric and Richard Adler and these students of the Naval Postgraduate School (NPS) have teamed with engineers at SPAWAR Systems Center, San Diego (SSC San Diego) to conduct theoretical and experimental research towards this goal. We have termed this merging, Combat Wear Integration (COMWIN). The electromagnetic real estate available on the soldier is limited to the helmet, the vest (flak jacket), and the pants. Only these parts of the uniform provide enough area to have any hope for making an efficient antenna in the frequency range of 2 to 2000 MHz. A thorough examination of the literature indicated that little research had been done to accomplish this task. Research also indicated that no one antenna was adequate to cover such a broad band.

During FY 1999, research indicated that an antenna in the form of a vest could provide coverage for the high Very High Frequency (VHF) to Ultra High Frequency (UHF) bands. Further research showed that an antenna conformal to the Kevlar helmet could cover the high UHF band (Adams et al., 1999). The primary result from the FY 1999 effort was the fabrication and testing of the Mark I vest antenna. This antenna could fit over a moderately sized man. The material was a commercially available copper interwoven with polyester sewed onto a canvas backing. Copper tape was used in places for soldering because of the low melting point of the material. A 1-inch-wide gap that was parallel to the ground divided the vest into two regions of approximately equal area. A Radio Frequency (RF) transformer reduced the 125-ohm impedance in the 100- to 500-MHz frequency range to near 50 ohms. Testing results showed that the VSWR was less than 3.1:1 for all frequencies between 100 and 500 MHz and that the polarization was vertical in the horizontal plane for frequencies less than 250 MHz. The pattern was also omni-directional in the horizontal plane for frequencies less than 250 MHz. The antenna gain varied from 2 dBi at 100 MHz to 6 dBi at 500 MHz.

The fabrication and testing of the Mark I COMWIN vest antenna also fulfilled a goal for the FY 1999 effort. The theoretical model of the antenna using the software program, GNEC, was largely validated. The predictions of the impedance from the GNEC were within 10% of the measurements for almost all frequencies without any adjustable parameters. The predictions of the azimuth and elevation radiation patterns were extremely similar with the one adjustable parameter of the maximum level.

Several features of the Mark I vest antenna required further research. The vest became electrically large at frequencies greater than 250 MHz. The radiation patterns developed large nulls and maximums. The polarization became mixed at these higher frequencies. Although this mixed polarization might be a worthwhile feature in certain applications (if the radio operator were prone, the polarization would then be vertical), such a result would not attain the figure of merit. The primary limitation of the Mark I vest is that its frequency range of efficient operation is greater than 100 MHz. For frequencies less than 100 MHz, the VSWR of the COMWIN Mark I vest antenna was larger than 4:1.

If efficient operation could be obtained for the COMWIN vest antenna at frequencies less than 100 MHz, the polarization would most probably be vertical. The pattern would also be omni-directional in the horizontal plane.

There are three primary goals of the FY 2000 effort. The first goal is to fabricate and test different models of COMWIN vest antennas to delineate further the parameters that would meet all the requirements. The second goal is to fabricate several models of a helmet antenna and assess their characteristics. The third goal is to measure, assess, and, if necessary, mitigate the radiation hazards from the COMWIN antenna system.

MARK II COMWIN VEST

The goal of the COMWIN vest antenna is to have a VSWR of 3:1 over the frequency range from 30 to 500 MHz. Such a frequency range would cover the SINCGARS band (30 to 88 MHz), the UHF line-of-sight band (225 to 400 MHz), and the Enhanced Position Location Reporting System (EPLRS) band (425 to 450 MHz). The COMWIN Mark I vest antenna met this figure of merit only in the 100- to 500-MHz band. Research must be done to extend the effective band to lower frequencies.

One approach to producing an antenna that operates at lower frequencies was to make the gap saw-toothed rather than straight. Making the gap into a saw-toothed pattern increased the path length. NPS researchers tried dozens of theoretical models using the GNEC code. Using a saw-toothed pattern reduced the minimum frequency of operation. Unfortunately, the impedance at the higher frequencies often had unacceptably large variations.

A second approach was to use a type of dielectric loading. Dielectric materials can lower the effective frequency of an antenna by slowing down the velocity of an electromagnetic wave. This lowering of the effective frequency occurs at the cost of the total bandwidth of the antenna. Unfortunately, GNEC cannot deal with dielectric materials. Either a more sophisticated code is necessary (NPS has used the commercial HFSS code developed by Ansoft with its finite element method for this purpose) or the effects of dielectric materials must be determined experimentally. The behavior of the vest with dielectric is important in two effects: (1) the flak jacket, and (2) the man wearing the vest.

The flak jacket is made primarily of Kevlar with a dielectric constant of 2.5 over the main frequencies of interest. The flak jacket will have some effect on the low frequency part of the band. A person has a highly complex distribution of dielectric and conductivity that varies with frequency, location in the body, and level of activity. Theoretical models have been developed in academic circles for use in electromagnetic studies. The Electrical Engineering Department of the University of Utah is especially active in this area. Cell phone manufacturers have also developed proprietary models. Experimental methods are probably the only inexpensive way to determine the effect of the person on the antenna.

As shown in the experimental results on the Mark I vest antenna, the effect of the human on the impedance is to lower the frequency of efficient operation. Figure 1 shows the magnitude of the impedance of the Mark I antenna with and without a person inside.

Figure 1 shows that the effect of the person is significant, especially at frequencies less than 100 MHz. The electrical properties of the person reduce the peak impedance at the resonance by a factor of 3. The variations in impedance at frequencies larger than 100 MHz are also reduced. The effect of the wearer is to make the antenna more easily matched to 50 ohms. Although there is less loss caused by the mismatch of the transmitter to the antenna, the person would probably absorb some of the energy. The absorption of energy by the body would probably reduce the gain of the antenna.

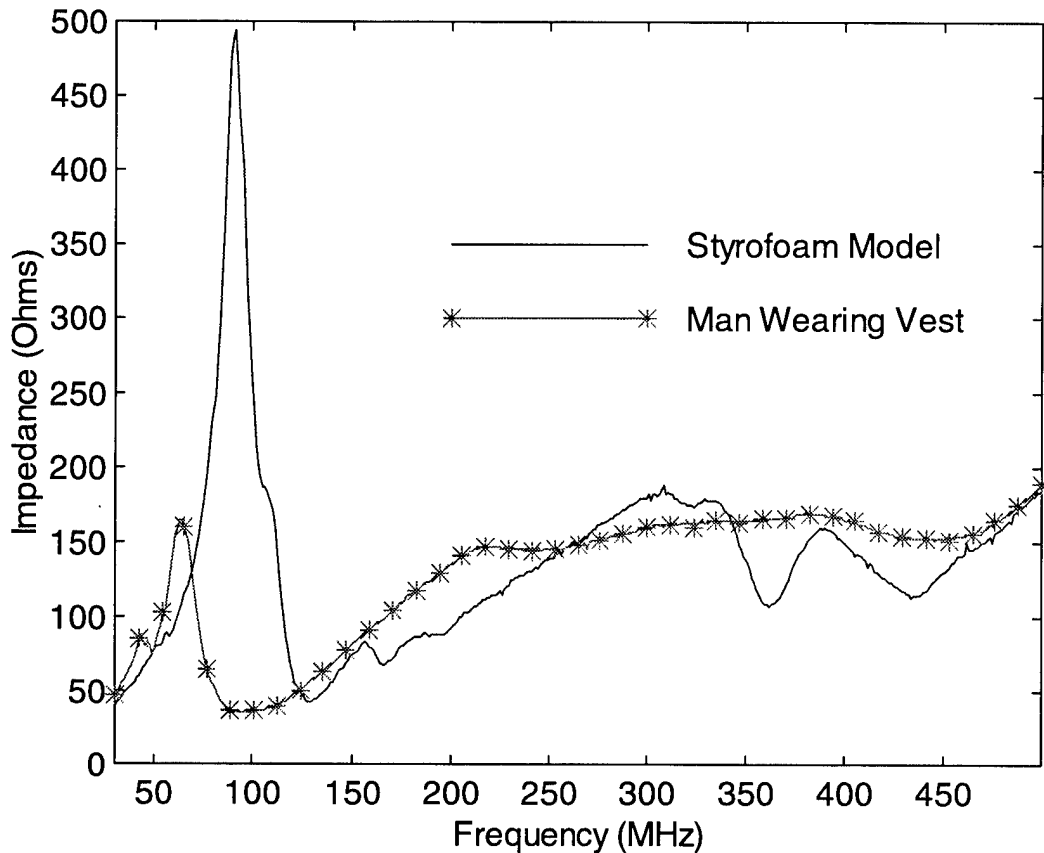

Figure 1. Effect of a person on COMWIN Mark I vest antenna impedance.

FABRICATION

Four distinct models of the vest antenna were fabricated during FY 2000. CAPT T. M. Gainor of NPS fabricated three models. Bob O'Neill of the Model Shop at SSC San Diego fabricated the fourth model. The models differ in the saw-toothed pattern of the gap, whether or not they have open sides, and the location of the feed region. All models were composed of FLECTRON (conductive interwoven polyester manufactured by APM of St. Louis, MO) sewed over canvas (Adams et al., 1999). Copper tape was added at points in which soldering was done. Both the NPS and SSC San Diego models had the shorting strap in the front of the vest as described by Adams et al. (1999).

There was also a difference in philosophy in the development of the NPS models compared to the model fabricated at SSC San Diego. NPS researchers sought to have a broadband, efficient antenna without adding such electronic devices as a transformer. This limitation led to investigation of different feed mechanisms to match the antenna efficiently to the rest of the circuit.

There were three basic NPS models. The first model had sides that were closed (i.e., there was no gap in the FLECTRON near the sides). The second model had a gap at the sides (called open sides). For these two models, the feed was connected at the bottom (called lower feed). In the third model, the center conductor crossed the gap from the top (called upper feed) and the sides were closed.

The SSC San Diego model was somewhat similar to the NPS model that had closed sides and lower feed. The Model Shop fabricated the saw-toothed structure so that the angles at the apex were

approximately 60°. The peak-to-peak height of the gap was somewhat smaller at the sides than at the front or back. Figure 2 shows the front and rear views of the COMWIN Mark II vest antenna developed at SSC San Diego. The rear view shows the feed and the RF transformer in the gap of the antenna. The size of the Mark II was large enough so that the vest could fit over a flak jacket covering a large man.



Figure 2. Front and rear views of COMWIN Mark II vest antenna.

IMPEDANCE

CAPT Gainor measured the impedance of the three versions of the NPS vest antenna with a Hewlett Packard 8510C network analyzer at 101 frequencies between 45 and 500 MHz under several different types of conditions. The variations in conditions consisted of the vest antenna over a Styrofoam model, over a flak jacket over a Styrofoam model, and over a flak jacket covering a person.

Figure 3 compares the impedance for two types of NPS vest antennas (by impedance we always mean its absolute magnitude). One has closed sides. The other has open sides. There is very little difference between the two antenna types. Figure 4 shows a similar comparison between the NPS vest antennas with a lower feed and with an upper feed. There is a significant difference between the two antenna types. The upper feed shows larger variations in impedance. Such variations would make it difficult to use a technique such as a transformer to match the impedance for acceptable efficiency over the frequency band.

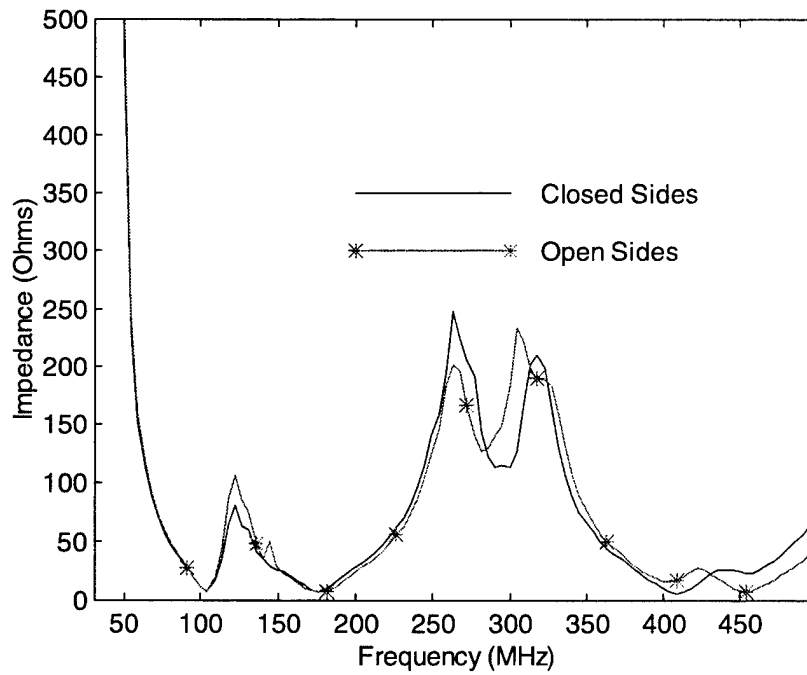

Figure 3. Comparison of impedance of closed-side and open-side versions of NPS vest antennas.

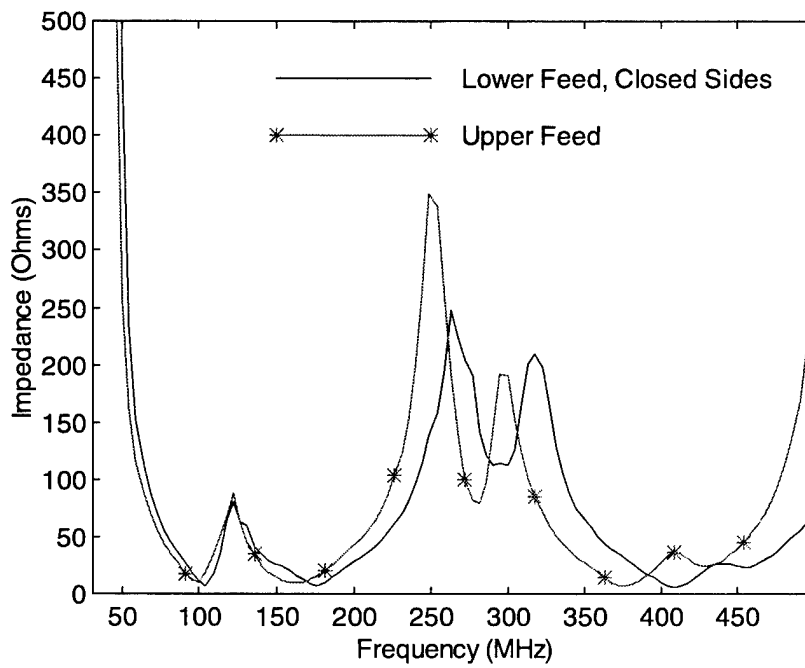

Figure 4. Comparison of impedance of upper feed and lower feed of NPS vest antennas.

The impedance of the COMWIN Mark II vest antenna was measured during March 2000 at the SSC San Diego Model Range. A Hewlett Packard 8537C network analyzer measured the reflection coefficient at 401 frequencies between 30 and 500 MHz. There were four variations for every type of measurement. The first variation used a Styrofoam model. The second variation used the antenna over a flak jacket over the Styrofoam model. The third variation used the antenna over a person. The fourth variation used the antenna over the flak jacket over a person. An occasional fifth variation used the antenna over the flak jacket over the Mark I antenna (used as a radiation shield) over a person. The purpose of this last variation was to determine whether a metal shield useful for mitigating radiation hazards would degrade the antenna efficiency. The measurements were usually conducted at a height of approximately 32 inches above a ground plane. Different people were used for versions of the measurements. After we completed the series of measurements, we inserted a transformer to reduce the antenna's impedance, and repeated the measurements.

Figure 5 compares the impedance of the Mark II vest antenna with the Mark I. The SSC San Diego Model Shop fabricated both antennas. The Mark II shows greater variation in the impedance. This variation makes the matching of the antenna somewhat more difficult. This difficulty will lead to a larger variation in the VSWR of the Mark II. Efficiency will be somewhat larger than that of the Mark I at some frequencies, and worse at other frequencies.

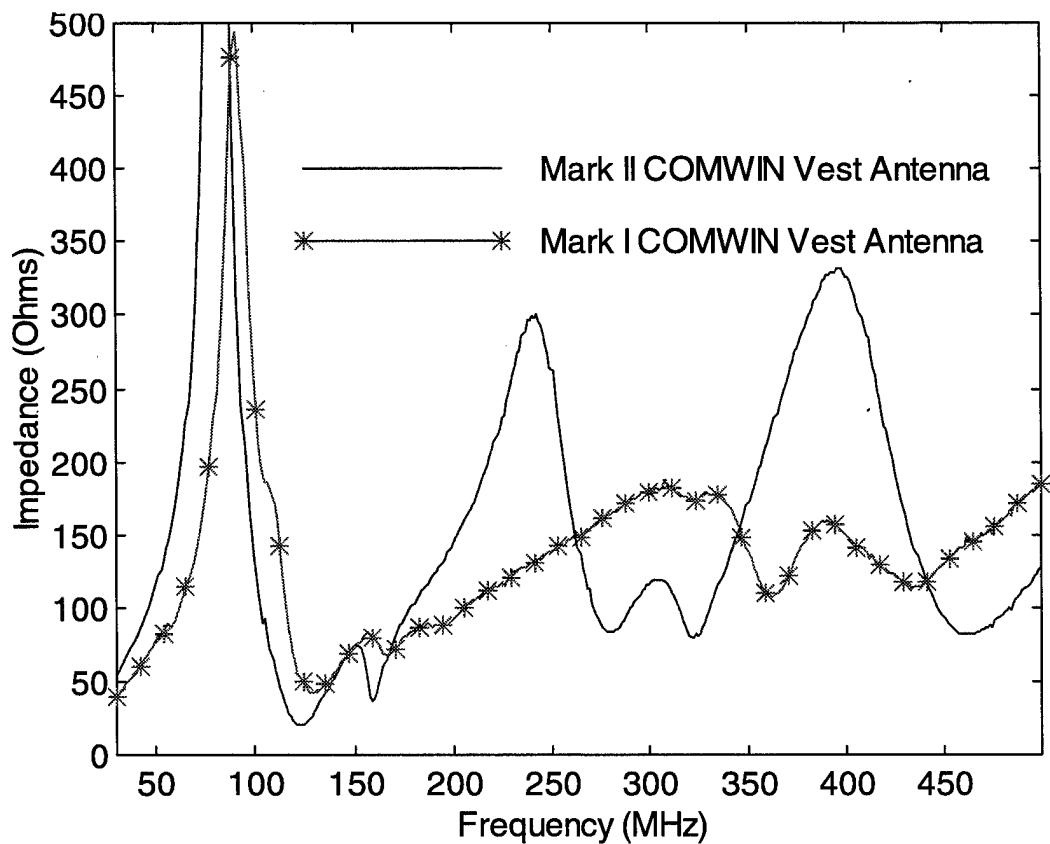

Figure 5. Comparison of SSC San Diego Mark I and Mark II vest antenna impedance.

Figure 6 compares the VSWR of the Mark II vest antenna after the introduction of the RF transformer into the circuit with the Mark I with the RF transformer. The Mark I has less variation in impedance with frequency than the Mark II. Thus, the transformer is much more effective in matching the antenna to the rest of the circuit. Mark I antenna impedance is approximately 125 ± 25 ohms. Mark II impedance is near 150 ± 100 ohms. This implies that more sophistication is needed for matching the Mark II than the Mark I. Mark I vest antenna VSWR was less than 3:1 for 237 out of 401 frequencies between 30 and 500 MHz. Mark II VSWR was less than 3:1 for only 137 of those frequencies. For a few frequencies (250 and 400 MHz), Mark II VSWR was much closer to 1:1 than the Mark I. There is a very good match that would lead to high efficiency for these frequencies.

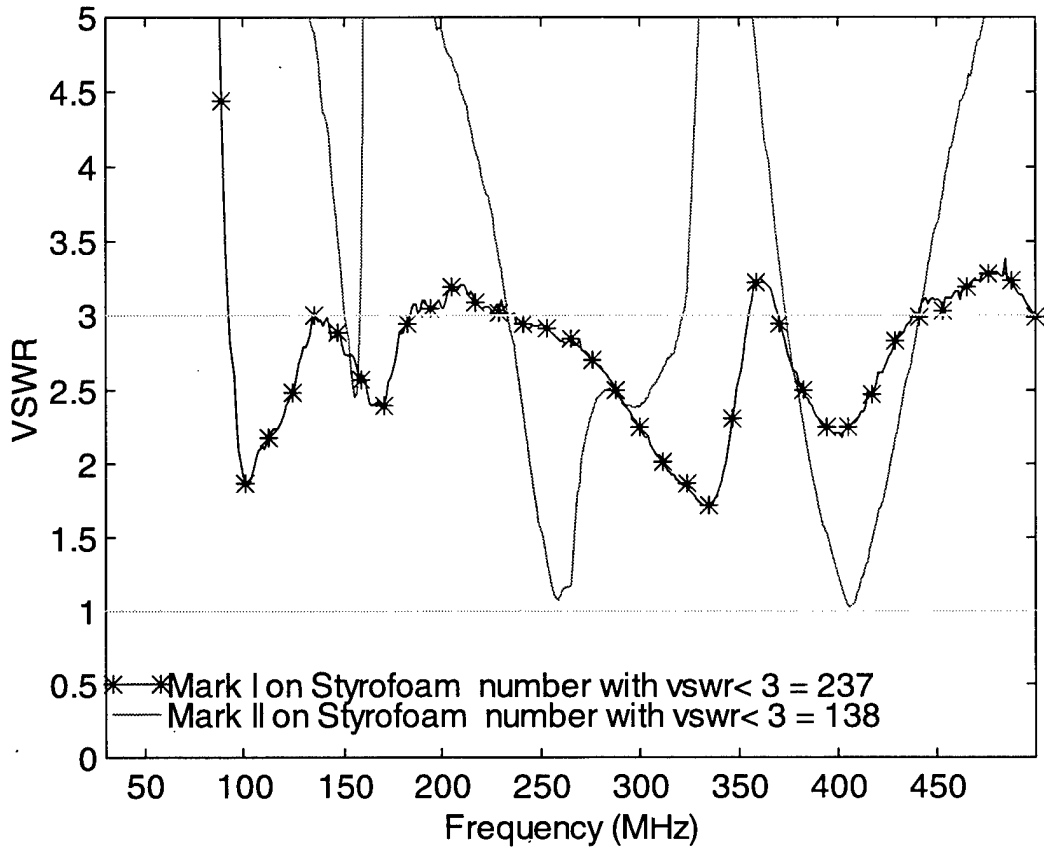

Figure 6. Comparison of Mark I and Mark II vest antenna impedance after introduction of RF transformer.

Putting the COMWIN Mark II vest antenna on a person has a good effect upon the impedance and the matching. Figure 7 compares the Mark II vest on the Styrofoam model and on a person. In both cases, a flak jacket is under the vest antenna. The person has a significant effect on the matching at frequencies below 100 MHz. The person reduces the maximum impedance near the resonance, and smoothes out the ripples for the higher frequencies. The number of frequencies at which the VSWR was less than 3:1 increased from 137 to 200 out of the 401 frequencies between 30 and 500 MHz.

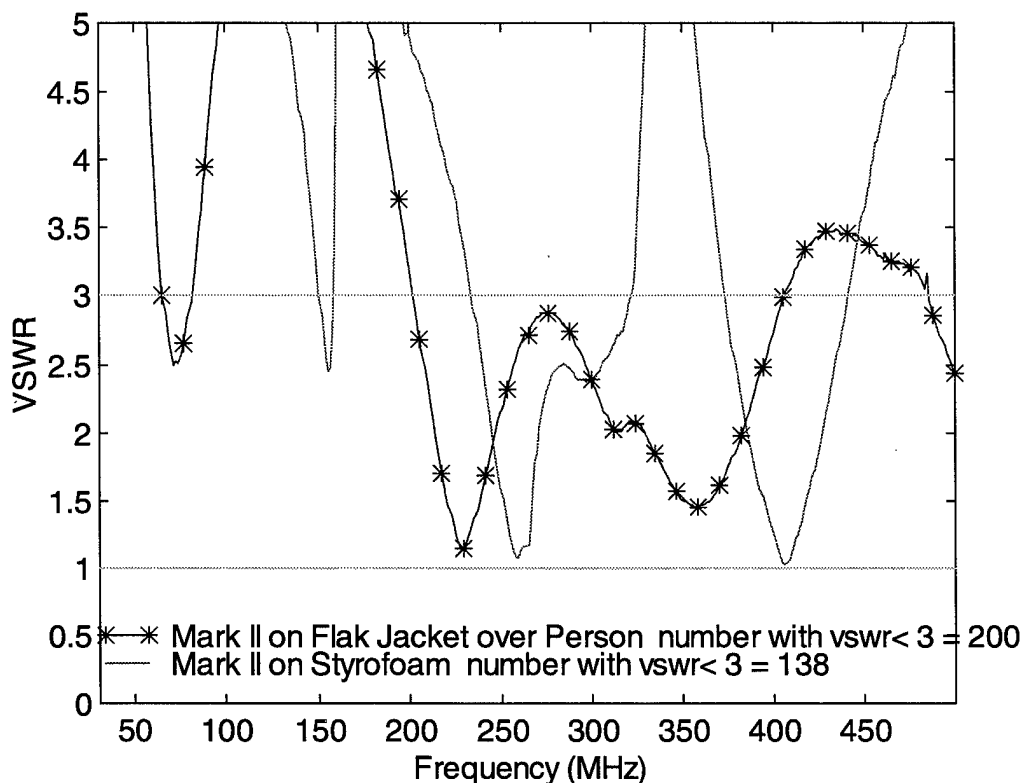

Figure 7. Effect of a person on Mark II vest antenna impedance.

Figure 8 compares VSWR versus frequency for the cases in which the Mark II COMWIN vest antenna was on a person with and without a flak jacket. The presence of the flak jacket made the matching slightly worse. The number of frequencies in which the VSWR was less than 3:1 was 297 without the flak jacket and 200 with the flak jacket over the person. The VSWR was lower, especially at frequencies below 100 MHz for the situation without the flak jacket. This situation probably indicates that the vest antenna should be on the inside of the flak jacket and closer to the wearer for a better match.

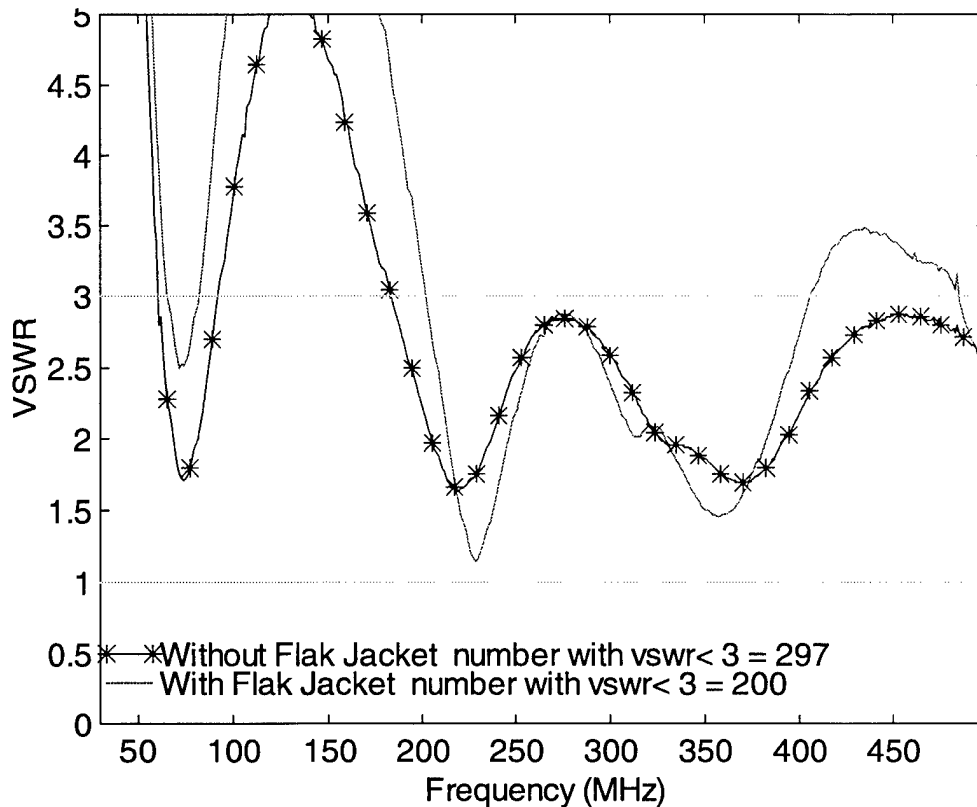

Figure 8. Effect of flak jacket on Mark II vest antenna impedance.

AZIMUTH PATTERNS

Radiation patterns were measured on the SSC San Diego Antenna Range from 15 May to 20 June 2000. These patterns were then plotted relative to an isotropic source. The receiving part of the Antenna Range is at Building 584, which is also called the West Tower. Building 584 is located at the edge of the Pacific Ocean. Building 592, located southeast of the West Tower across a valley, was the site for the transmitting antenna. The distance between transmit and receive antennas was 833 feet. There was no height difference between the transmitting antenna and the top of West Tower. The steep valley and the Pacific Ocean behind the West Tower mitigated reflections from the ground.

The measurement system is composed of a three-axis turntable, a Scientific Atlanta AS-1711 receiver, and a Fram and Russell FR-944 digital pattern recorder. A Hewlett-Packard VL/2 computer attached to the FR-944 and a bolometer recorded the data.

The transmitting antenna was a log periodic type connected to a signal generator. A log-periodic antenna whose gain was known for all frequencies between 30 MHz and 3000 MHz was the reference for measurement of test antenna gain. For some of the measurements, a 50-dB power amplifier provided greater signal-to-noise ratio. The signal generator was an HP 83712B synthesized Continuous Wave (CW) generator.

Figure 9 shows the azimuthal (horizontal plane) radiation patterns for the frequencies between 125 and 400 MHz in steps of 25 MHz. The figure also shows the gain at boresight (defined as the front of the vest in the horizontal plane). The pattern is isotropic for frequencies between 125 and 175 MHz. At a frequency of 200 MHz, a null starts to form at the location of the feed. The null becomes more pronounced as the frequency increases. The null then migrates to the sleeve region, where it becomes highly pronounced.

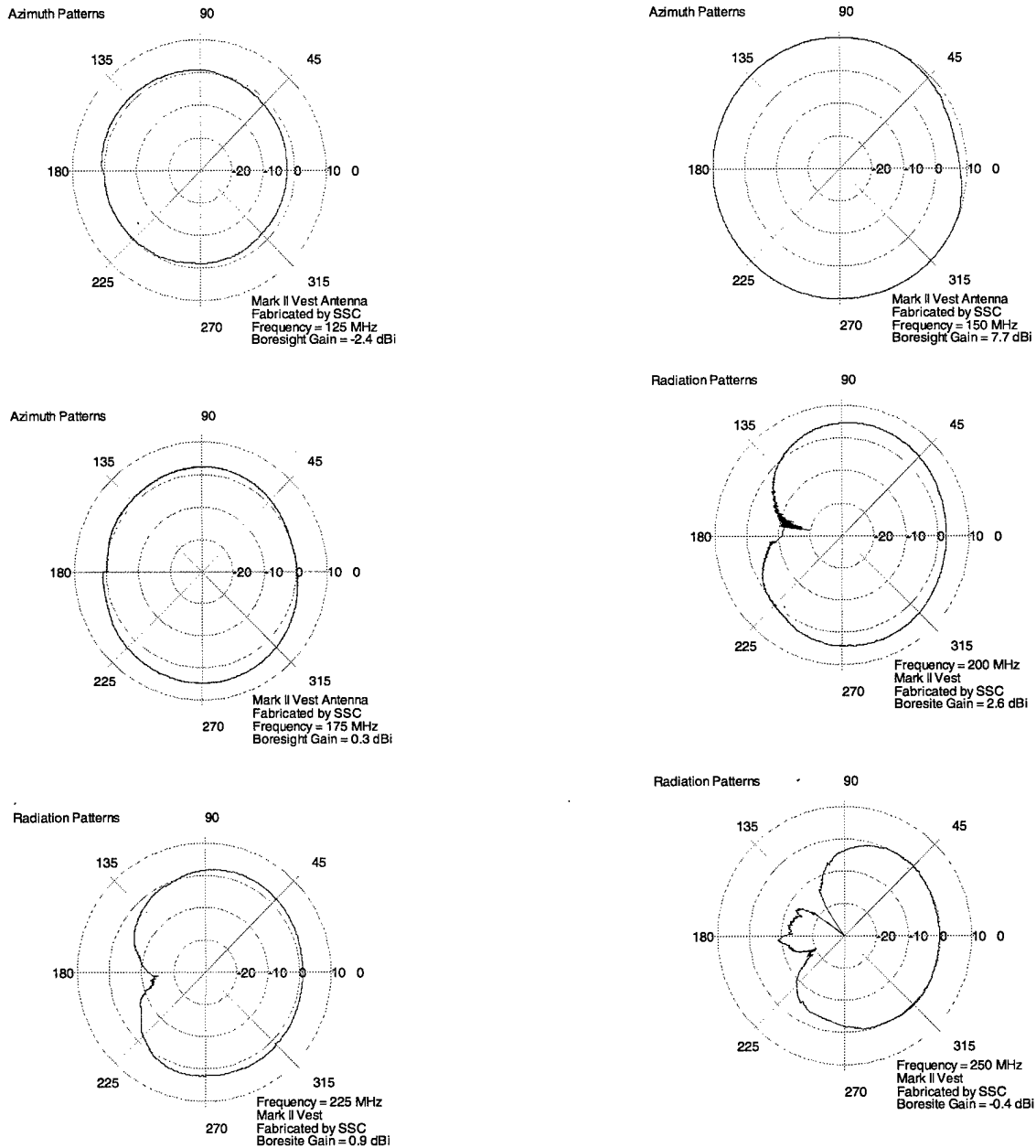

Figure 9. Radiation patterns in the horizontal plane for the Mark II vest antenna for frequencies between 125 and 400 MHz in steps of 25 MHz.

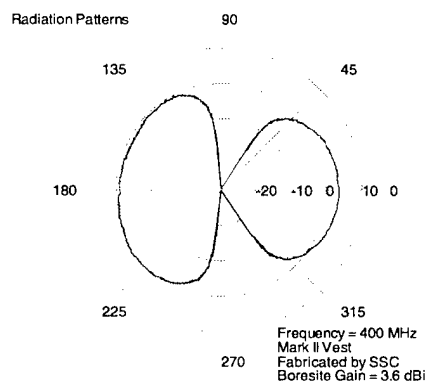
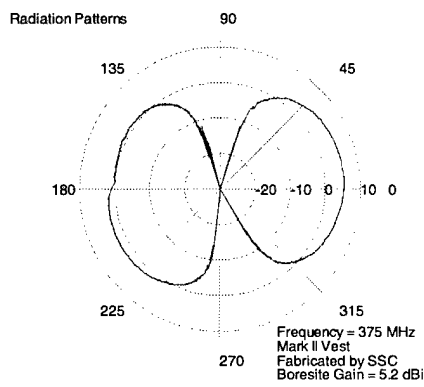
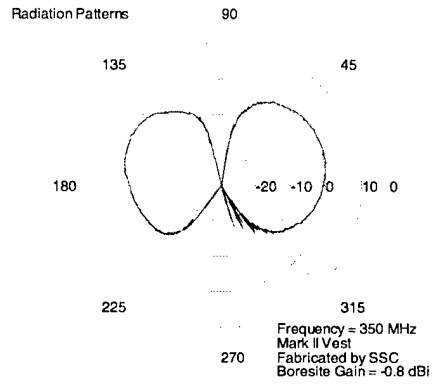
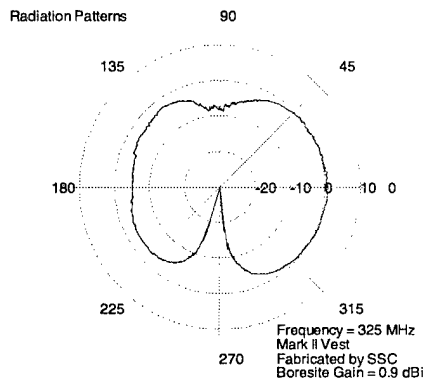
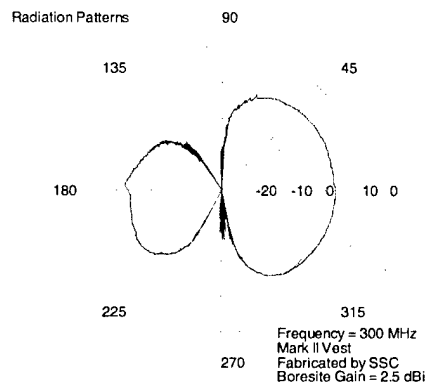
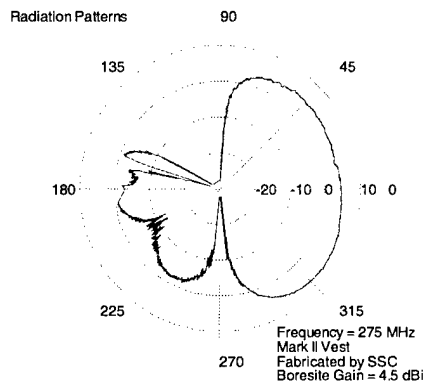

Figure 9 (continued). Radiation patterns in the horizontal plane for the Mark II vest antenna for frequencies between 125 and 400 MHz in steps of 25 MHz.

GAIN

The gain relative to an isotropic source was measured by comparing the signal received at the test antenna with that received at the standard antenna. The COMWIN Mark II vest antenna was measured with the front facing the transmitter (south) or with the left shoulder facing the transmitter (front facing west). The gain was measured with a calibrated Tektronix 495P spectrum analyzer on 26 May 2000 at the West Tower. A 50-dB amplifier was used to raise the signal 30 dB above the noise floor. The amplifier has a frequency range between 1.5 and 400 MHz. The difference in signal between the standard and the COMWIN vest antenna was measured at 10-MHz increments between 50 and 410 MHz.

Figure 10 shows the gain relative to an isotropic source of the Mark II COMWIN vest antenna. The gain with the vest facing the transmitter is almost always larger than that facing 90° away. The gain for the former is almost always larger than 0 dBi for frequencies greater than 90 MHz. For the set of frequencies, the minimum gain is -0.8 dBi at 350 MHz. The maximum gain is 5.2 dBi at 375 MHz. The boresight gain at 50 MHz was -13.1 dBi, which was the lowest gain measured.

Such a result is consistent with that obtained for the Mark I vest. The gain of the Mark I vest measured on the SSC San Diego Antenna Range had a minimum gain of 2 dBi at a frequency of 100 MHz and a maximum of 6 dBi at 500 MHz. Because the radiation patterns were measured at only five frequencies, little of the structure of the gain versus frequency could be obtained. Because of mismatch loss, the gain at lower frequencies was likely to be very low for the Mark I vest antenna.

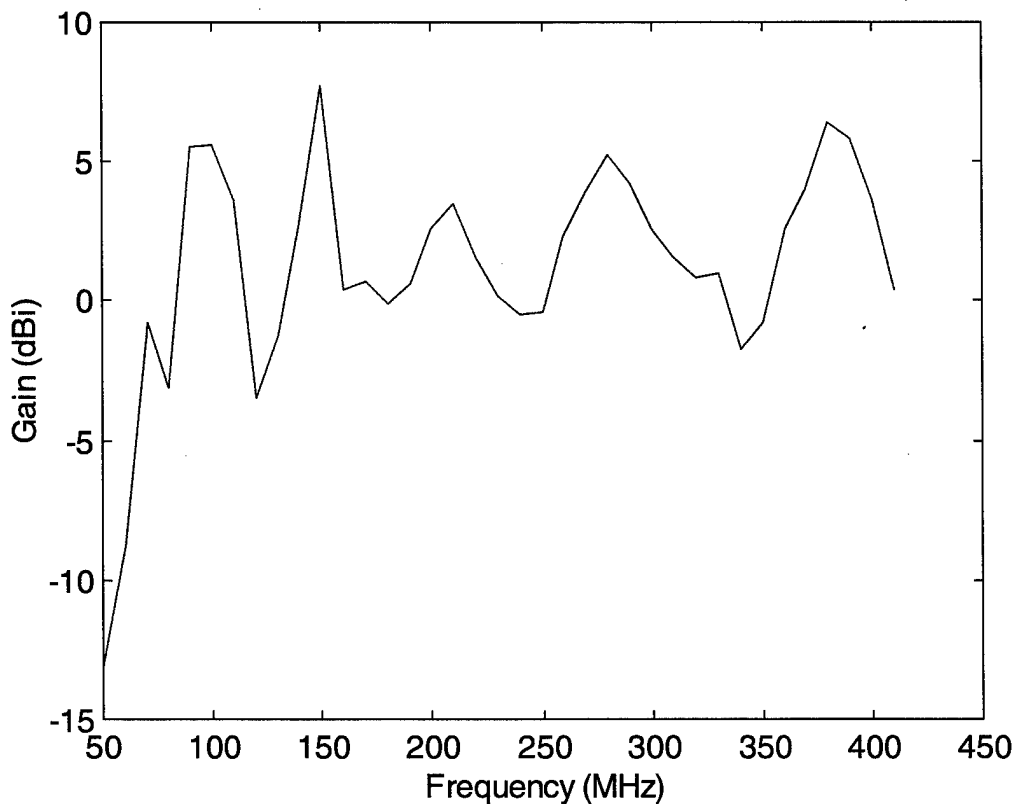

Figure 10. Boresight gain versus frequency for Mark II vest antenna.

POLARIZATION

The polarization was measured at the same time as the gain. The radiation plane of the transmitting antenna was rotated to horizontal. Both signals from the vertically oriented COMWIN antenna and the horizontally oriented standard were measured with the spectrum analyzer. The front of the vest faced the transmitter. Figure 11 shows the results for the difference between the vertically and horizontally polarized signal. The vertically polarized signal was larger than the horizontally polarized one for all frequencies larger than 90 MHz. For lower frequencies, the horizontal gain was larger than the vertical.

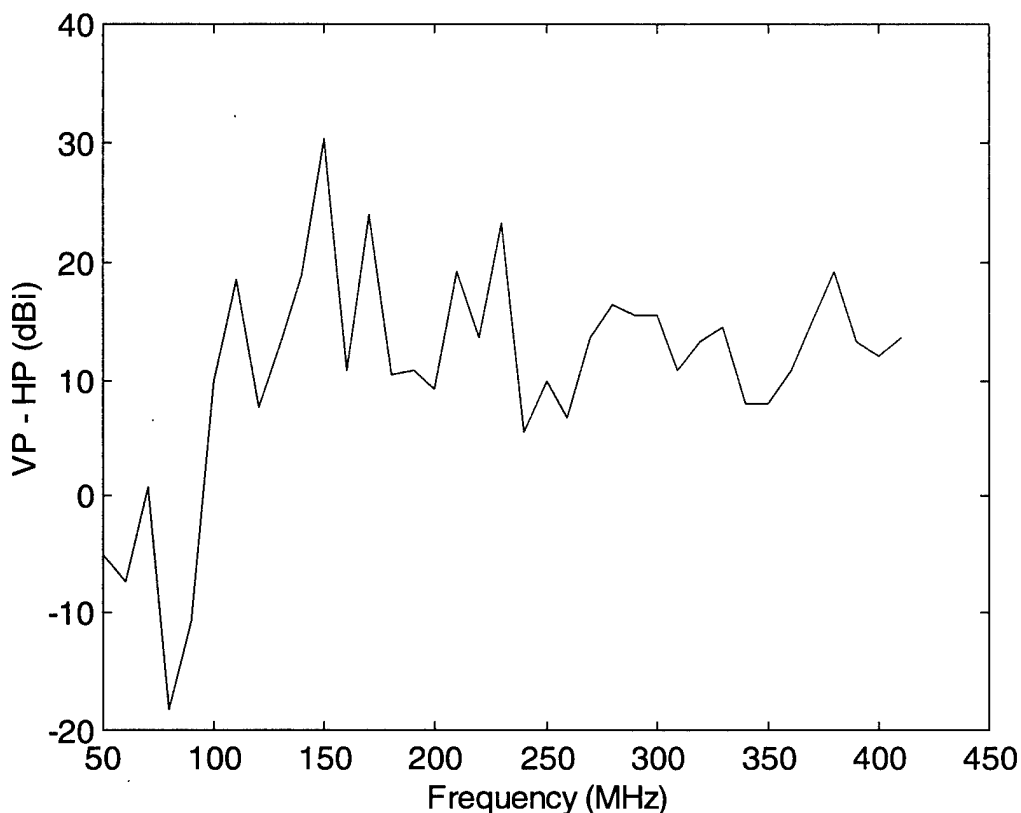

Figure 11. Difference of boresight gain between vertical and horizontal polarizations versus frequency for Mark II vest antenna.

The corresponding result for the Mark I vest antenna was that the polarization was almost completely vertical at frequencies less than 200 MHz when measured in the horizontal plane. The polarization became mixed for higher frequencies. For frequencies above 300 MHz, there were azimuths at which the horizontal gain was larger than the vertical gain.

ELEVATION PATTERNS

Elevation patterns were measured at 5° increments using a spectrum analyzer and the Mark II vest mounted on the turntable. Only the elevation pattern in the plane of the feed was measured. Figure 12 shows the elevation patterns relative to that measured at boresight for frequencies between 125 and 400 MHz in increments of 25 MHz. The maximum gain was rarely at boresight. Often, the maximum

gain was at a lower elevation angle different from the horizontal plane. Similar to the Mark I vest antenna, the elevation pattern often had nulls. The number of nulls increased with frequency. At an elevation angle of -90° , the bottom of the vest was facing the transmitter. Correspondingly, at an angle of 20° , the top of the vest was closer to the transmitter.

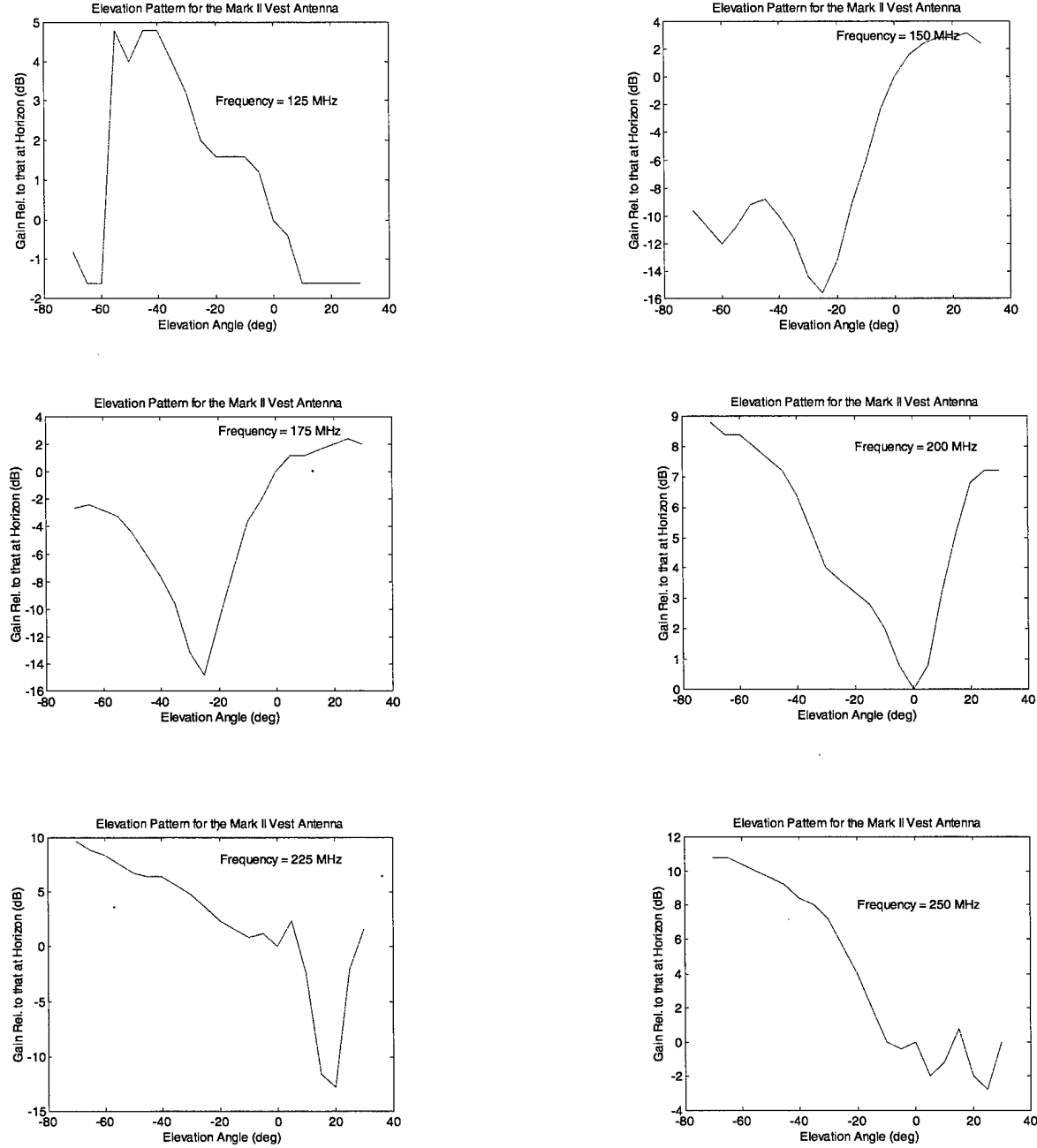

Figure 12. Radiation patterns versus elevation angle for frequencies between 125 and 400 MHz.

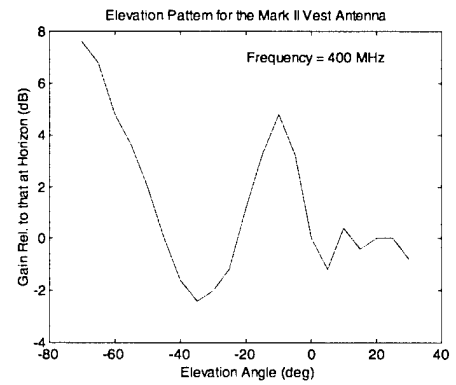
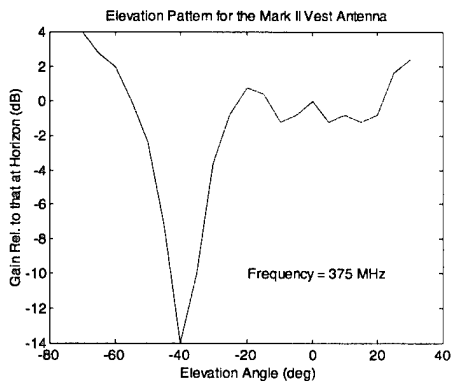
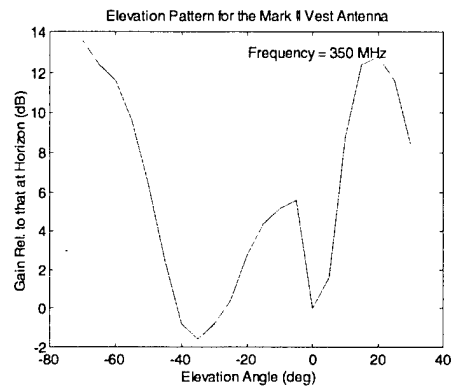
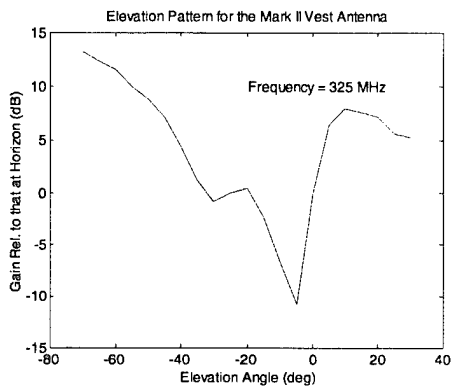
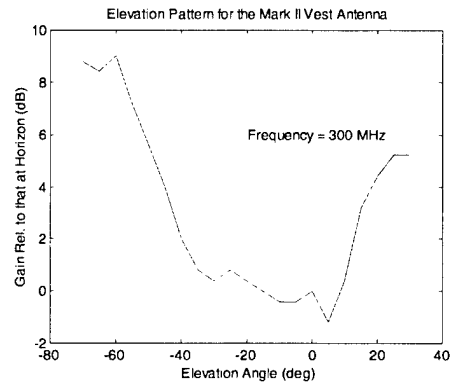
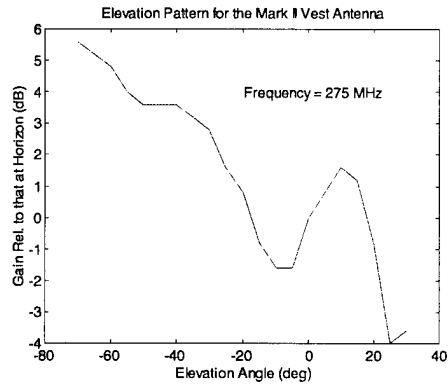

Figure 12 (continued). Radiation pattern versus elevation angle for frequencies between 125 and 400 MHz.

CONCLUSIONS CONCERNING CHARACTERISTICS OF MARK II VEST AS AN ANTENNA

The Mark I vest antenna with a straight gap usually has better VSWR as a function of frequency than the Mark II with a saw-toothed gap. The patterns and gain are comparable (those of the Mark I were not measured for frequencies less than 100 MHz). Both antennas have nulls in the pattern for frequencies greater than 200 MHz. Because of smaller variations, Mark I impedance for the higher frequencies is more easily matched than the Mark II. Mark II impedance with a person inside has a good VSWR for frequencies between 40 and 60 MHz.

All models of the Mark II vest antenna are badly mismatched in the set of frequencies between 90 and 110 MHz. These frequencies constitute the Frequency Modulation (FM) band for commercial broadcasting in many countries including the United States. It is unlikely that these frequencies will ever be used for military communications. The trend is to expand the commercial band at the expense of the military. Thus, the gap in the transmission band can be used to make the antenna more efficient in the usable bands. These bands include 30- to 88-MHz and 110- to 500-MHz bands. An electro-mechanical switch, or possibly a diplexer, can direct the signals to different circuits attached to the same antenna, maximizing efficiency in the more limited band. The cost in performance is to relinquish the possibility of instantaneous frequency hopping from a signal in the lower band to a signal in the higher band. There would instead be instantaneous hopping within the 30- to 88-MHz or the 110- to 500-MHz band.

COMWIN MARK I HELMET ANTENNA

NPS researchers fabricated a helmet antenna. They used a gap that was oriented parallel to the ground and straight. The gap separated the top and the bottom of the helmet so that the area of one was approximately the same as the area of the other. The VSWR was the lowest over the frequency range from 500 to 2000 MHz when the gap was 0.5 cm. Unfortunately, there were several regions of frequency in which the VSWR became large. The helmet was given to SSC San Diego for testing.

IMPEDANCE

COMWIN Mark I helmet antenna impedance was measured on the SSC San Diego Model Range on 1 March 2000. As mentioned, the SSC San Diego Model Range has a HP 8537A network analyzer that measures the reflection coefficient, impedance, and VSWR at 401 frequencies. This capability was applied to the Mark I helmet antenna for frequencies between 300 and 2000 MHz. The reason for measuring the impedance at frequencies that overlap those of the vest antenna was that the latter became electrically large at frequencies above 300 MHz. The radiation patterns exhibited lobes in the azimuth and elevation planes. Thus, if the helmet could radiate efficiently at frequencies below 500 MHz, the smaller size of the helmet would probably produce an isotropic pattern.

Figure 13 shows the Mark I helmet antenna impedance for three cases. In all cases, the impedance was measured with the helmet 6 feet above a ground plane. The first case is the antenna on Styrofoam. The second case is for the antenna on a standard Kevlar helmet, also on the Styrofoam model. The third case is for the antenna on the helmet on a person. In all three cases, the VSWR is larger than 3:1 for most frequencies. The large amount of mismatch has a bad effect upon patterns and gain. Antenna efficiency is low for frequencies less than 1000 MHz.

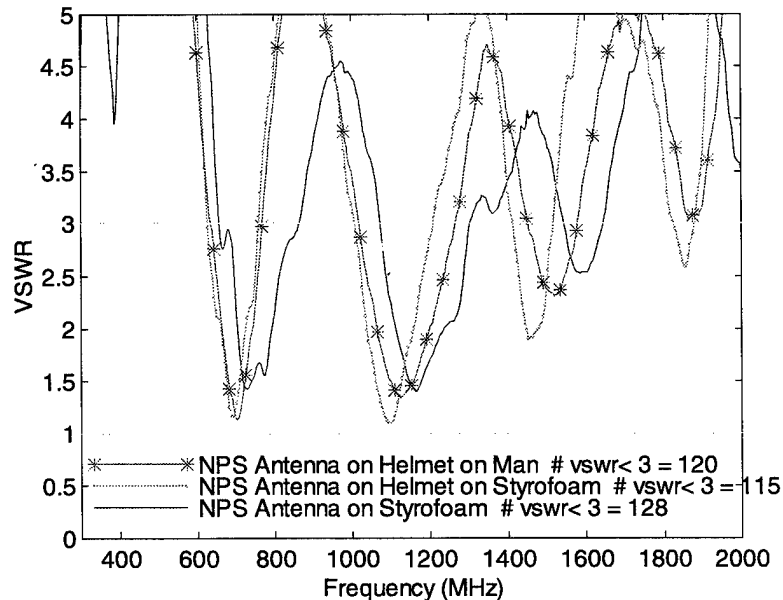

Figure 13. VSWR versus frequency for NPS COMWIN Mark I helmet antenna.

GAIN

Figure 14 presents the boresight gain of the Mark I helmet antenna compared to that of the Mark II (to be described later) as a function of frequency. The signal was measured at 10-MHz increments for all frequencies between 300 and 1800 MHz. The boresight direction would correspond to the soldier facing the transmitter. Methods of gain measurements were similar to those of the vest antenna. A calibrated Tektronix 495 P spectrum analyzer measured the difference in signal level between the helmet antenna and a standard gain, log periodic antenna. The transmitting antenna was a vertically oriented dipole. The measurements were made in the Anechoic Chamber (Building 377). The HP CW generator was used for the transmission. A Mini-Circuits low-noise amplifier provided 30 dB more gain in the signal.

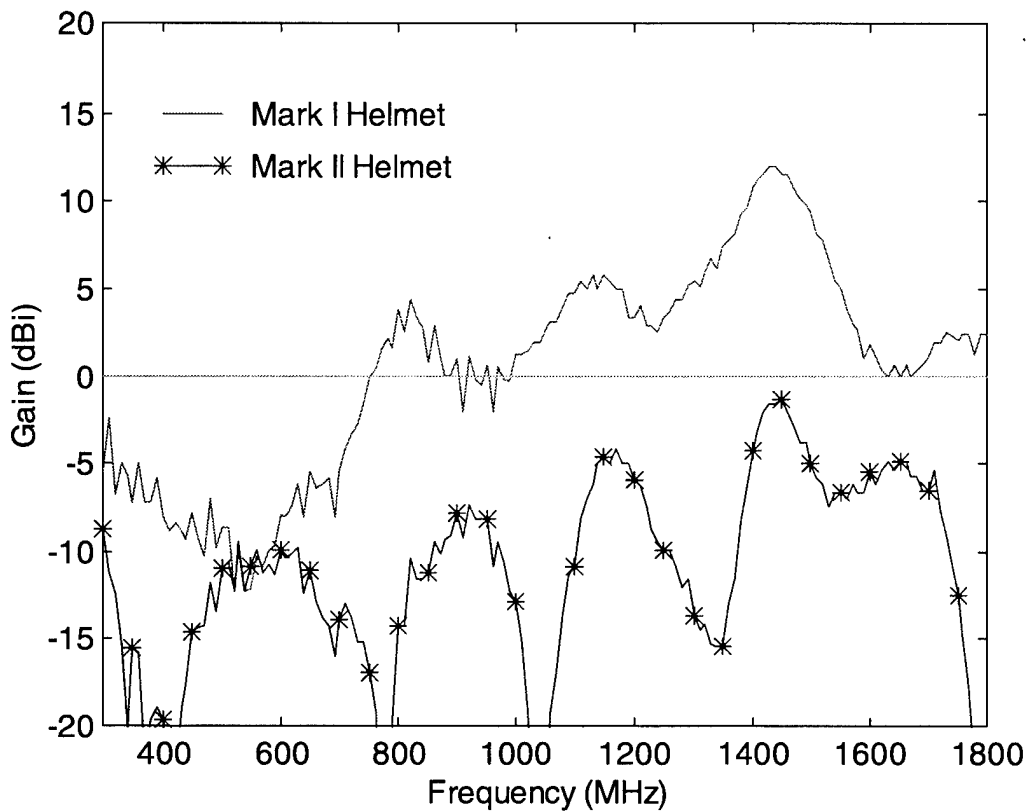

Figure 14. Boresight gain of Mark I and Mark II helmet antennas versus frequency.

The gain of the Mark I helmet antenna becomes greater than 0 dBi for most frequencies larger than 800 MHz. The gain becomes quite large (near 15 dBi at 1500 MHz) for frequencies larger than 1200 MHz. The increased number of nulls in the patterns (to be shown in later sections) causes the boresight gain to be large. The energy is concentrated into smaller angular sections.

POLARIZATION

Figure 15 shows COMWIN Mark I helmet antenna polarization as a function of frequency. The vertical and horizontal gains were measured as a function of frequency at 10-MHz increments between 300 and 1800 MHz. A vertically or horizontally oriented dipole was used as the

transmitting antenna. The signal in each orientation was measured and compared to that from a calibrated log periodic antenna to determine the gain.

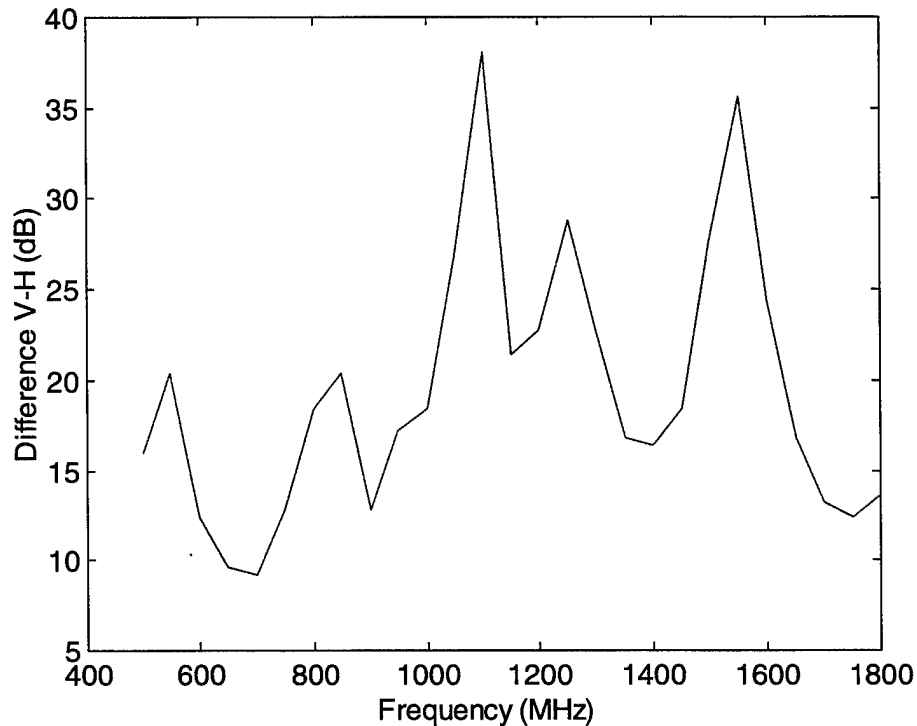

Figure 15. Difference in vertical gain at boresight with the horizontal gain as a function of frequency for Mark I helmet antenna.

The vertical gain at boresight is larger than the horizontal for all frequencies between 300 and 2000 MHz. This difference varies from a minimum of 8 dBi to a maximum of 40 dBi. There might be a purpose for making the polarization circular rather than linear. If the helmet is used for communications with satellites, circular polarization is needed. To accomplish this change in polarization, a change in feed would be required. Vertical polarization meets the requirements stated in the introduction.

AZIMUTH PATTERNS

Radiation patterns in the azimuth plane were measured in an Anechoic Chamber (Building 377) of SSC San Diego on 19 July 2000. Figure 16 shows the radiation patterns as a function of azimuth at the horizon for frequencies between 300 and 1800 MHz in 100-MHz steps. The patterns were measured with the Tektronix spectrum analyzer at an angular interval of 5° . A spline was used to interpolate for an angular increment of 1° .

Figure 16 shows gain versus azimuth relative to the isotropic source. Boresight gain (0°) is given on each plot. The signal was normalized by the gain measured at boresight. The scale was kept constant so that the contraction of the radiation patterns could be compared between frequencies. For all frequencies larger than 500 MHz, the antenna was electrically large. For these frequencies, there is a minimum of one lobe in the pattern. The number of lobes increases as the frequency increases.

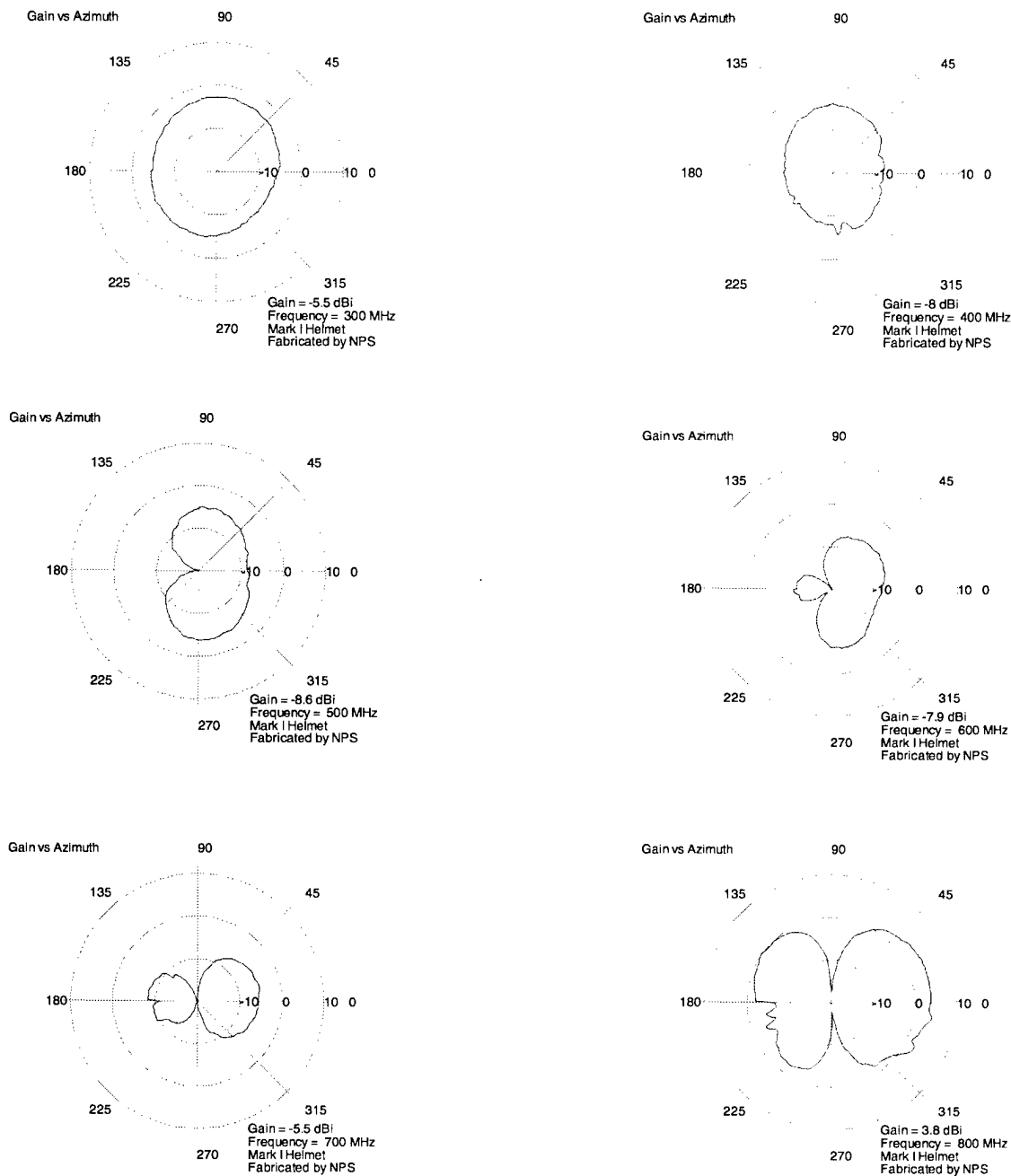

Figure 16. Radiation patterns in horizontal plane versus frequency for Mark I helmet antenna.

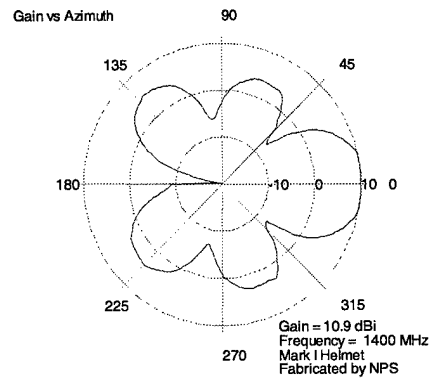
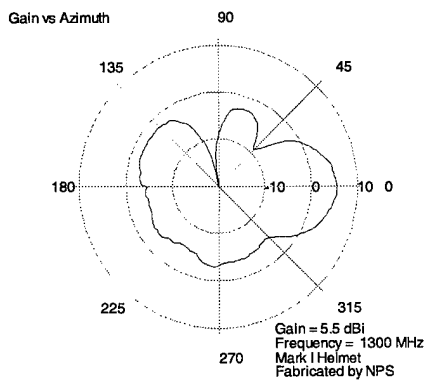
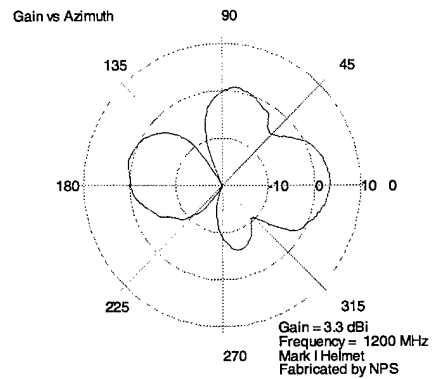
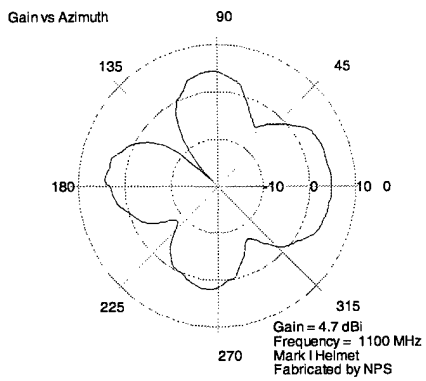
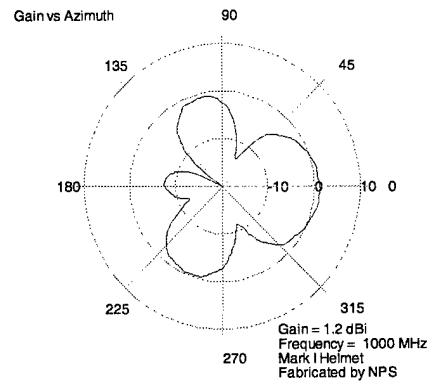
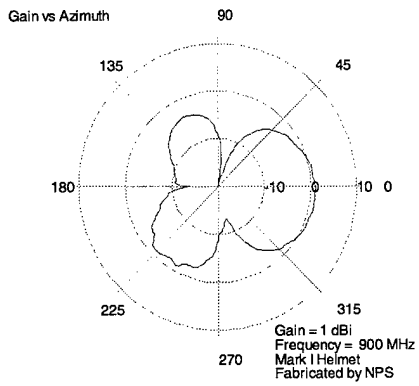

Figure 16 (continued). Radiation patterns in horizontal plane versus frequency for Mark I helmet antenna.

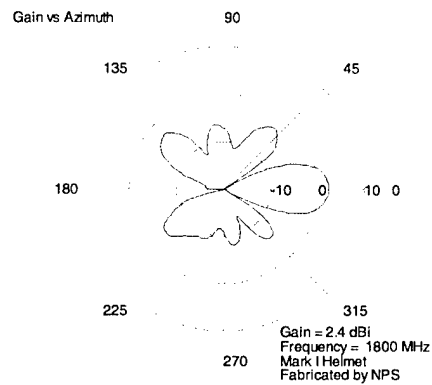
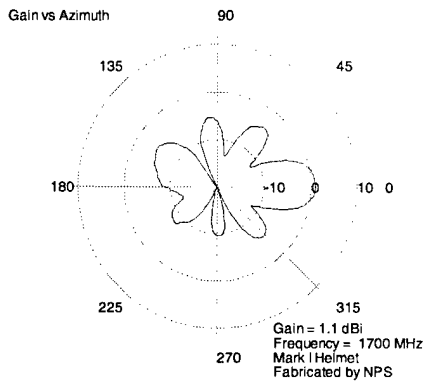
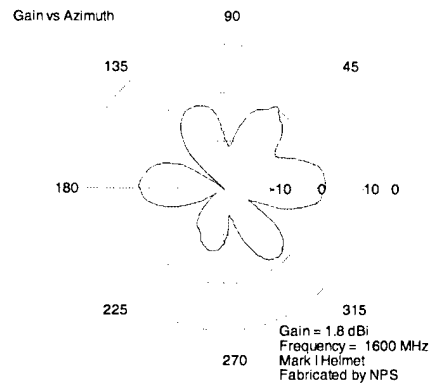
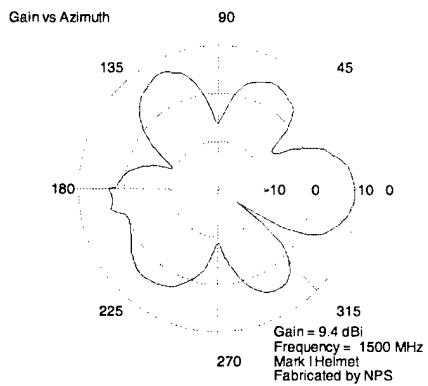

Figure 16 (continued). Radiation patterns in horizontal plane versus frequency for Mark I helmet antenna.

ELEVATION PATTERNS

The patterns in the elevation plane were also measured in the Anechoic Chamber using the vertical dipole and the spectrum analyzer. The increment of angle was 5° . Figure 17 shows the signal relative to that at boresight versus elevation angle and frequency for the Mark I helmet antenna. The elevation pattern was measured for frequencies between 500 and 1700 MHz, with a frequency interval of 100 MHz.

The helmet antenna often has the maximum gain at elevation angles higher than the horizon. Research must be done to ensure that the maximum gain is at the horizon. There are nulls at many frequencies above 800 MHz.

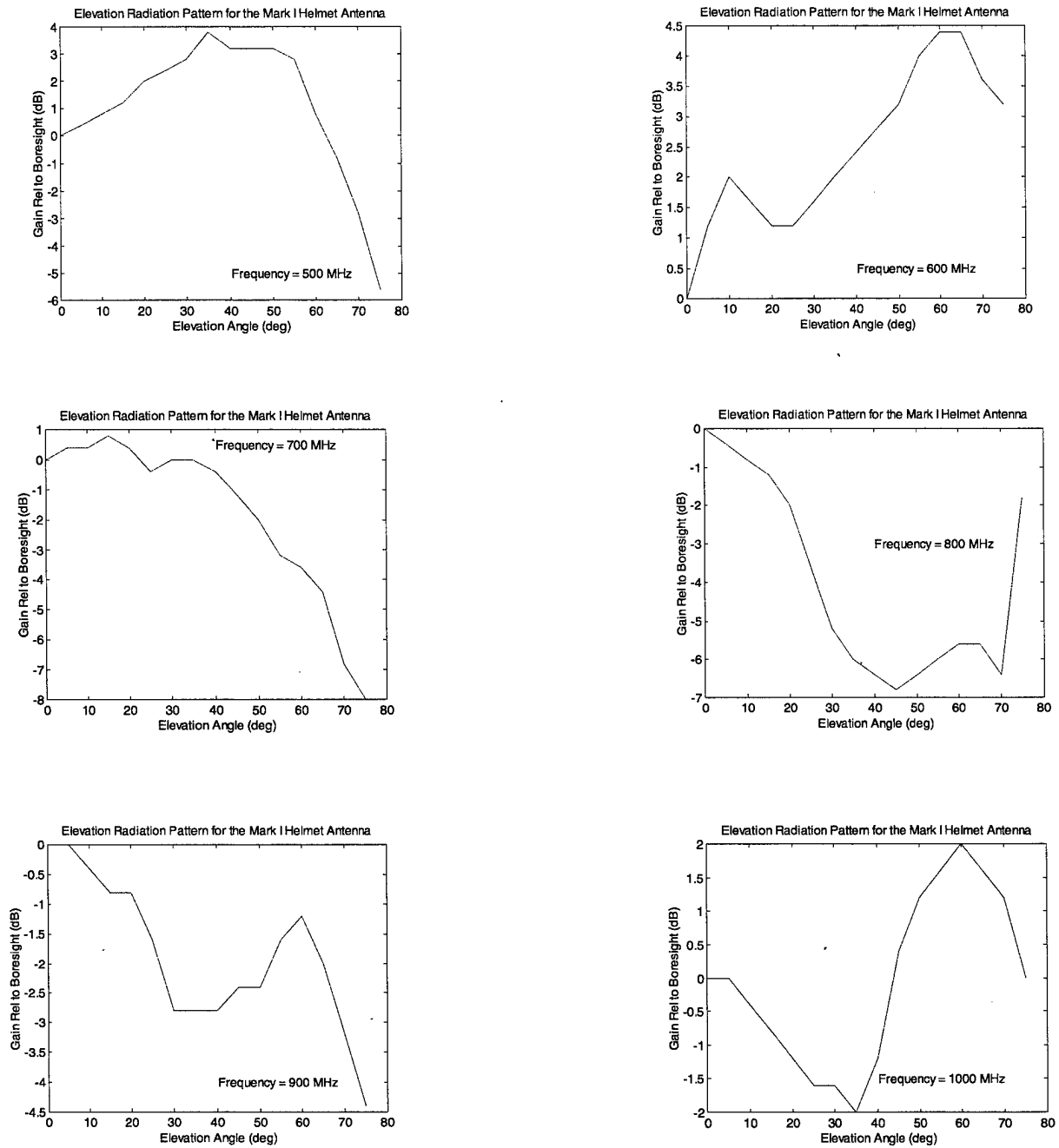

Figure 17. Signal relative to signal at boresight versus elevation angle and frequency for Mark I helmet antenna.

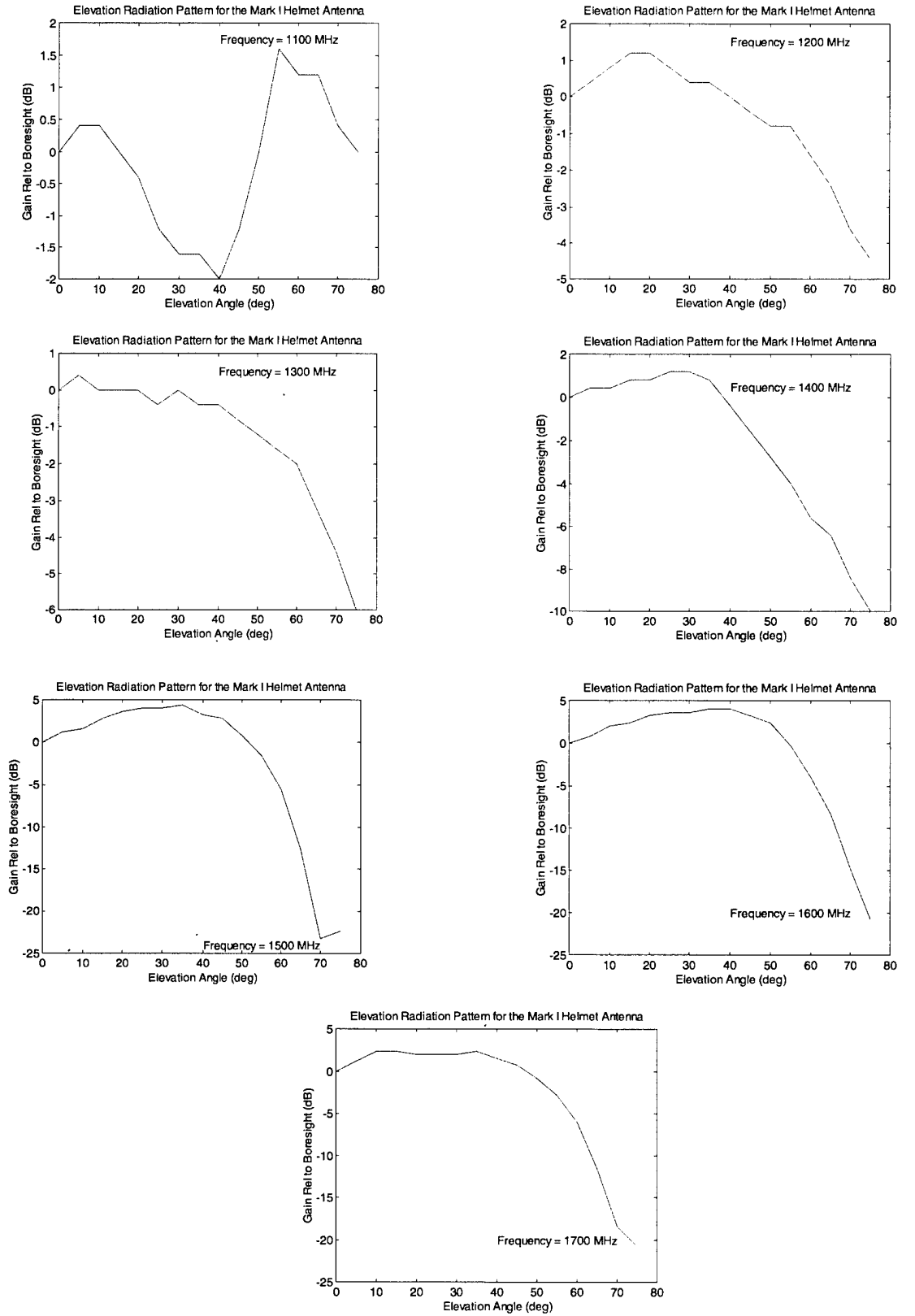

Figure 17 (continued). Signal relative to signal at boresight versus elevation angle and frequency for Mark I helmet antenna.

COMWIN MARK II HELMET ANTENNA

The primary differences between the Mark I helmet (fabricated at NPS) and the Mark II is that the latter has a gap with a saw-toothed pattern. The goal was similar to that of the vest antenna. The saw-toothed pattern should increase the usable frequency. The effect of the head upon the impedance of the antenna should be less than that of the body upon the vest antenna. These influences decrease as the frequency increases.

FABRICATION

After consultation with Professor Lebaric, the helmet antenna was fabricated at the SSC San Diego Model Shop. Several Kevlar helmets were borrowed to provide support for the antenna. The antenna covering, which provides camouflage, was the model for the overall shape of the antenna. Similar to the Mark II vest, the gap was a saw-toothed pattern. Unlike the vest, there was no shorting strap. Figure 18 shows a side view of the Mark I helmet antenna and a front view of the Mark II helmet antenna (fabricated by SSC San Diego). The gap on the Mark II is significantly larger than that of the Mark I. Captain Gainor added the copper tape to the Mark I helmet antenna to determine the optimum width of the gap. The best match of the antenna to the feed line was found when the gap was 0.5 cm.



Figure 18. Mark I helmet antenna (side view) and Mark II helmet antenna (front view).

IMPEDANCE

Mark II impedance was measured in a manner similar to that used to measure the Mark I helmet antenna. The HP 8537 network analyzer on the SSC San Diego Model Range measured Mark II impedance for 401 frequencies between 300 and 2000 MHz. In all cases, the helmet antenna was 6 feet above a ground plane during the measurement. Because of the very high frequencies involved, the ground plane should have virtually no influence upon the measurement. Figure 19 shows the VSWR relative to a 50-ohm load for antenna on Styrofoam, antenna on helmet on Styrofoam, and antenna on helmet on person.

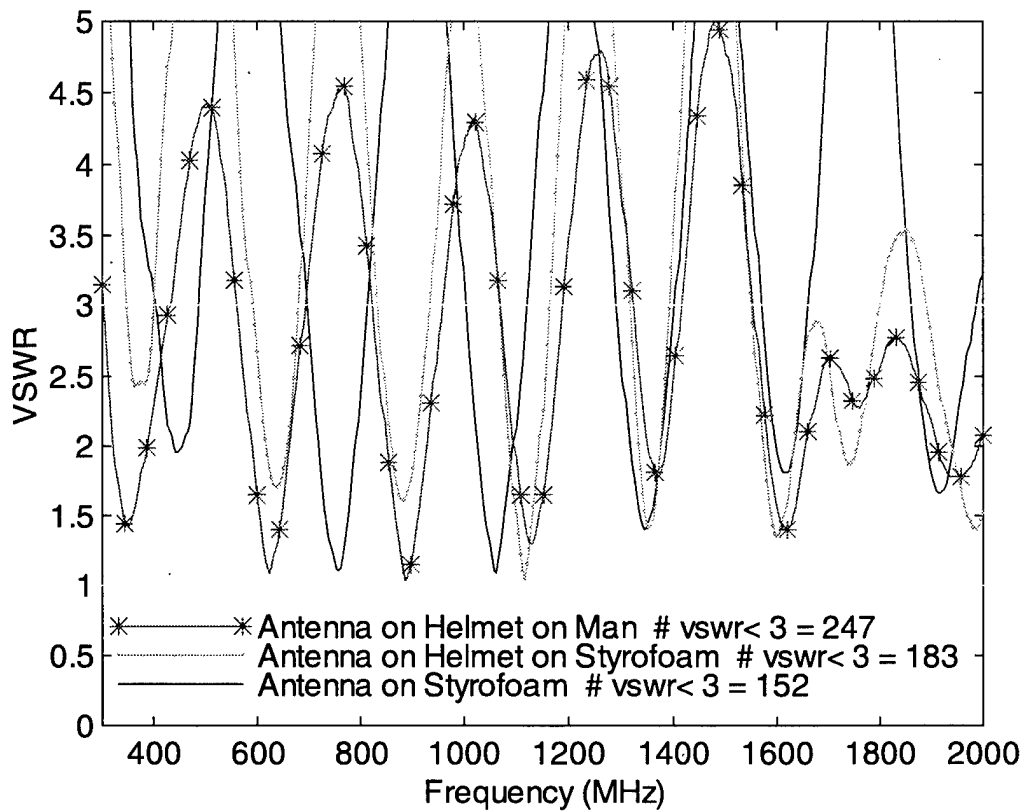

Figure 19. Mark II helmet antenna VSWR versus frequency for three conditions.

The presence of the person wearing the helmet has a modest, but good effect upon VSWR. For the antenna on the Styrofoam, the number of frequencies for which the VSWR was less than 3:1 was 152. The corresponding numbers for the antenna on a helmet on the Styrofoam and on a helmet on a person were 183 and 247, respectively. Both the head and the helmet reduce the fluctuations in impedance and make the antenna a better match to the feed line.

Figure 20 compares the VSWR of the Mark II (fabricated by SSC San Diego) to VSWR of the Mark I (fabricated by NPS). In both measurements, the antennas were on a helmet worn by a person.

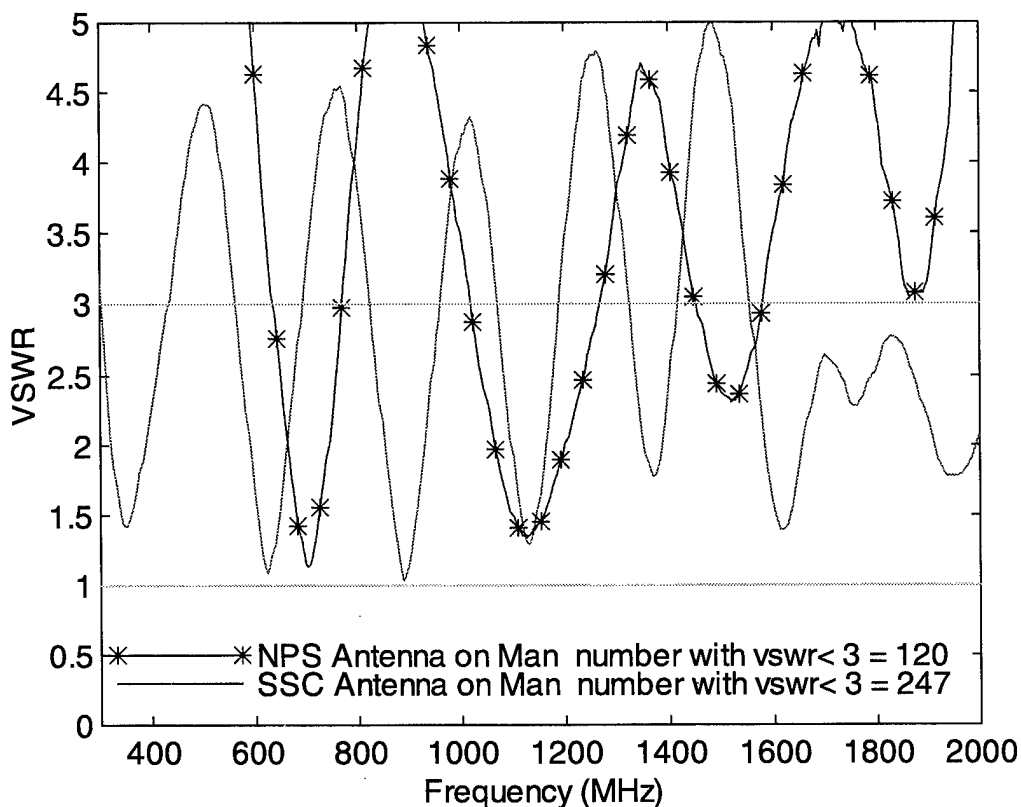

Figure 20. Comparison of Mark I and Mark II helmet antenna VSWR versus frequency.

In terms of impedance match, the Mark II is far superior to the Mark I. The VSWR of the former is never larger than 5:1. At 247 frequencies, the VSWR of the Mark II is less than 3:1. The Mark I satisfies this figure of merit for only 120 frequencies. The VSWR of the Mark I helmet antenna is often above 5:1.

AZIMUTH PATTERNS

Radiation patterns were measured in the Anechoic Chamber (Building 377) of SSC San Diego on 25 April 2000. The azimuth patterns were measured for frequencies between 500 MHz and 2000 MHz with a 100-MHz increment. A circularly polarized antenna was used for transmission. No elevation patterns were measured. Figure 14 shows the gain of the Mark II. A Scientific Atlanta Receiver, Model 1711-30 was used to measure the signal. A bolometer, Fram and Russell Interface, and a Hewlett Packard VL/2 computer with digital pattern recording software recorded the patterns.

Figure 21 presents these radiation patterns. The signal is normalized to the maximum in the pattern.

Similar to the Mark I, the patterns are of those of an electrically large antenna. There is no frequency at which there is no lobe. The number of lobes increases as the frequency increases. The low gain of the Mark II helmet antenna compared to the Mark I prevented further assessment of the patterns.

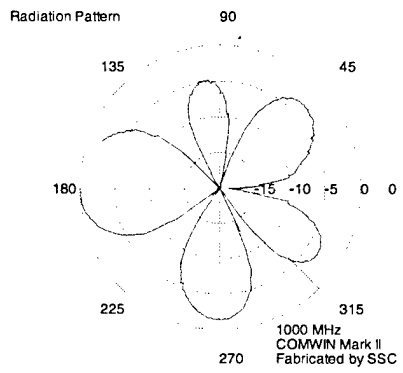
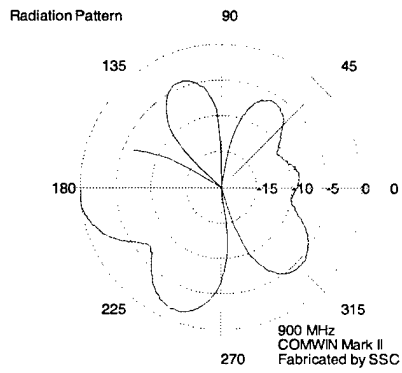
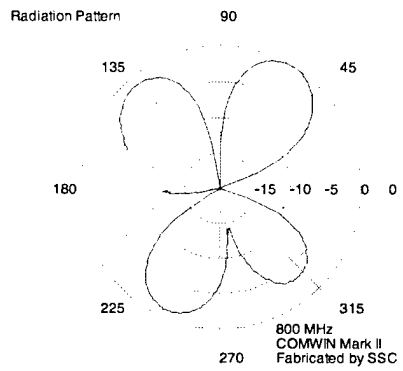
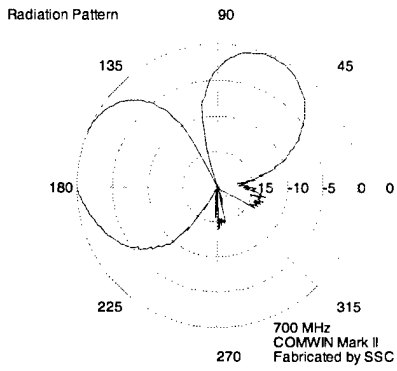
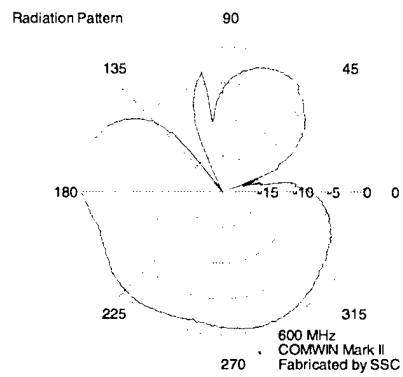
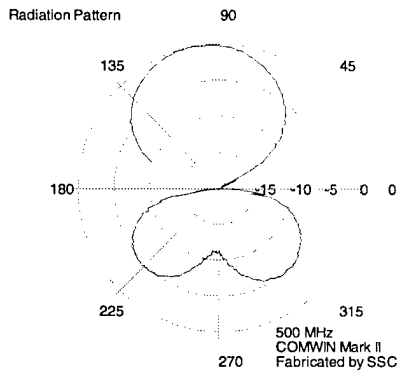

Figure 21. Radiation patterns of Mark II helmet antenna versus azimuth and frequency.

CONCLUSIONS ON MARK I AND MARK II HELMET ANTENNAS

The Mark I and Mark II helmet antennas were designed to be very different to assess the effect of the geometry of the gap upon performance. The differences are significant. The Mark II, with a saw-toothed gap, has an excellent VSWR versus frequency. The VSWR of the Mark II antenna over a helmet worn by a person never exceeds 5:1 for frequencies between 300 and 2000. The VSWR is often less than 3:1. The Mark I is not nearly as good. On the other hand, the gain for vertically polarized signals for the Mark I is almost always better than the gain of the Mark II. The patterns for the Mark I and Mark II have significant lobes. The number of lobes gets larger as the frequency increases.

For the vest and helmet antennas, a straight gap is preferable to a saw-toothed one. More of the models will be made and measured to determine the optimum arrangement of feed. Research must be done to decrease the number of lobes in the pattern. Presently, the gain for the Mark I is excellent for all frequencies larger than 800 MHz. Research must be done to ensure that the radiation pattern is concentrated in the horizontal plane. This can be done by systematically varying the amount of conducting material below and above the gap. Because the helmet is curved, there is probably an optimum ratio of material (below and above the gap) that concentrates the pattern in the horizontal plane while maximizing the gain.

RADIATION HAZARD ASSESSMENT ON COMWIN ANTENNAS

One of the primary requirements for any antenna is that it be safe to use. On a ship, this can be achieved by requiring a certain distance between personnel and the antenna that is radiating significant energy. A portable antenna does not have this luxury. The antenna must be safe for any input power and frequency with which it will be used. The antenna will be in close proximity at least to the radio operator.

One of the expected advantages of incorporating the antenna into the uniform is that the person will be largely shielded from exposure to high electromagnetic fields. The action of the antenna is largely that of a Faraday cage. This antenna action should be compared to the use of a dipole antenna (such as on a cell phone) in which the person is outside and close to the transmitter. For that case, high electromagnetic fields can be expected. The radiation hazard can be mitigated only by reducing the maximum input power and the range. Shielding the user is probably not possible.

A second reason for presuming that the radiation hazards for the wearable antenna are less than those of a dipole next to the user is the issue of power density. The maximum power density for the wearable antenna will probably be less than that of a dipole. The fields are spread over a large area (chest or head) rather than concentrated in a small region. The features of being within the cage and reducing the maximum power density will probably mitigate any radiation hazards for the wearable antennas.

GOALS

The Institute of Electronics and Electrical Engineers (IEEE) has published standards for radiation hazards from antennas. They are specific to controlled areas (those with personnel with knowledge of the hazards) and uncontrolled areas (people have no knowledge of the hazards). Standards for the latter are much more restrictive than for the former. The Department of Defense, the U.S. Navy, and IEEE have adopted the same standards (Institute of Electronics and Electrical Engineers, 1992; Department of Defense, 1995; Department of the Navy, 1999). These standards are largely based upon the thermal effects of the radiation. The assumption is that a person can withstand a 1°C rise in body temperature almost indefinitely. If the radiation is confined to a very small region of the body, a much larger rise in temperature can be withstood because of the cooling effect of blood circulation. Thus, the standard for a controlled area is based upon that amount of radiation impinging upon the whole body that would lead to a temperature rise of less than the stated amount. This amount is proportional to the mass of the body. The ratio of the power absorbed to the mass of the body is called the specific absorption rate. The controlled area maximum specific absorption rate is 0.4 W/kg. An exception is that for a small region (a cube with a 1-gram mass), the maximum specific absorption rate is 8 W/kg for a controlled area.

There are corresponding standards for the maximum permissible exposure (MPE). MPE is often related to the power density (power per unit area). If a plane wave is used to relate the power density to the maximum electric and magnetic field for much of the frequency spectrum between 30 and 300 MHz, the maximum electric field is given by 61.4 V/m. This maximum value rises slightly with increasing frequency. Using a plane wave relationship is probably not valid for frequencies less than 100 MHz. This relationship would depend on the detailed geometry. What is important is the amount of energy per unit time per unit mass that impinges upon the interior of the wearer. This amount of energy involves the analysis of the whole electromagnetic interaction between a complex antenna and a complex dielectric substance.

The SINCGARS man-carried radio is the standard we will adopt. With frequency coverage of between 30 and 88 MHz, the antenna has a maximum average input power of 4 W. We seek to meet all specific absorption rate and electromagnetic field requirements for a maximum input power of 4 W.

ELECTRIC AND MAGNETIC FIELD MEASUREMENTS

For the vest and helmet antennas, many measurements were obtained of the electromagnetic fields. For measurements close to the antenna and at the site of the person, an EMCO Electric Field Sensor was used. This calibrated sensor can measure the electric field for all frequencies between 1 and 1000 MHz. The EMCO probe is an isotropic sensor. Three mutually orthogonal components of the electric field are summed so that only the total field is measured. The probe is “non-perturbing” in that the connection between the sensor and electronic meter is fiber-optic. Although the electronic meter uses 60-Hz current, the interface unit is battery-powered. The minimum detectable electric field is 0.5 V/m.

At distances from the vest antenna on the order of 1 m, a perturbing probe can be used. The NARDA 8631 measures the magnetic field for frequencies between 10 and 300 MHz. The connection between the probe and the meter is metal. This feed perturbs the measurement if the probe is close to the antenna. We used the NARDA probe to measure the magnetic fields only if the input power was large and only at some distance away from the antenna.

Vest Antennas

Figure 22 shows a schematic of the locations at which the electric fields were measured. The primary locations for measurement were the feed region outside the vest (point A) and four locations along the center line of the vest. These are 20 cm below the vest (point B), at the lowest point in the vest (point D), in the center of the vest opposite the feed (point C), and at the top of the vest (point E). The field at the feed is needed for normalizing the result so that comparison between theory and experiment can be made. Points F, G, H, I, and J represent regions just outside the vest. Points K and L are far from the vest.

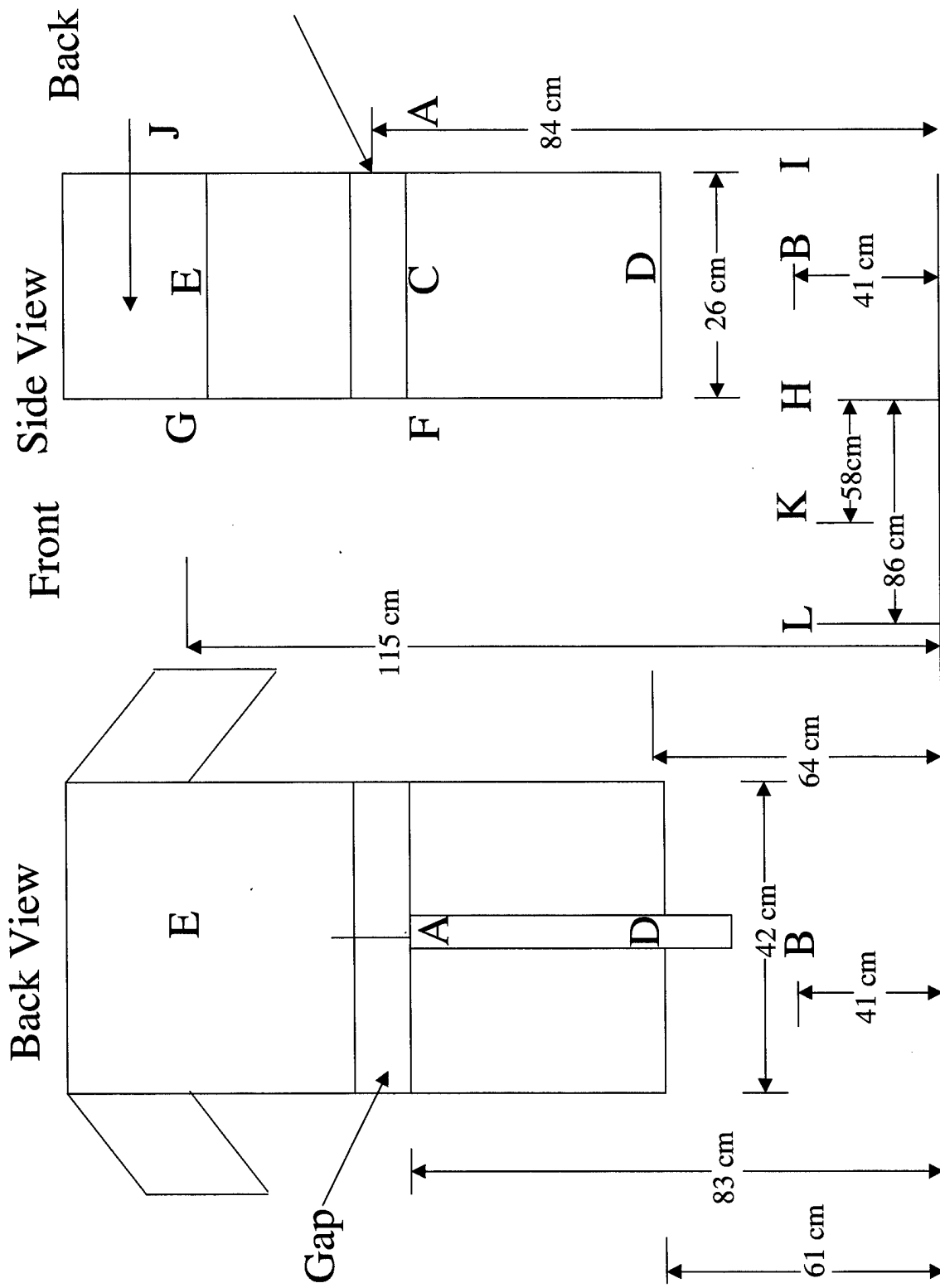

Figure 22. Location of measurement sites relative to vest antenna.

The first measurements confirmed the relationship between electric field and input power. Theory suggests that the electric field should be proportional to the square root of the input power. Figure 23 shows the measured electric field at one location (point A) for frequencies between 100 and 500 MHz for two values of the input power. The measured electric field for an input power of 10 dBm (0.01 W) was multiplied by 3.16 ($\sqrt{10}$) and the results compared to those of 20 dBm (0.1 W). The results are very close for almost all frequencies.

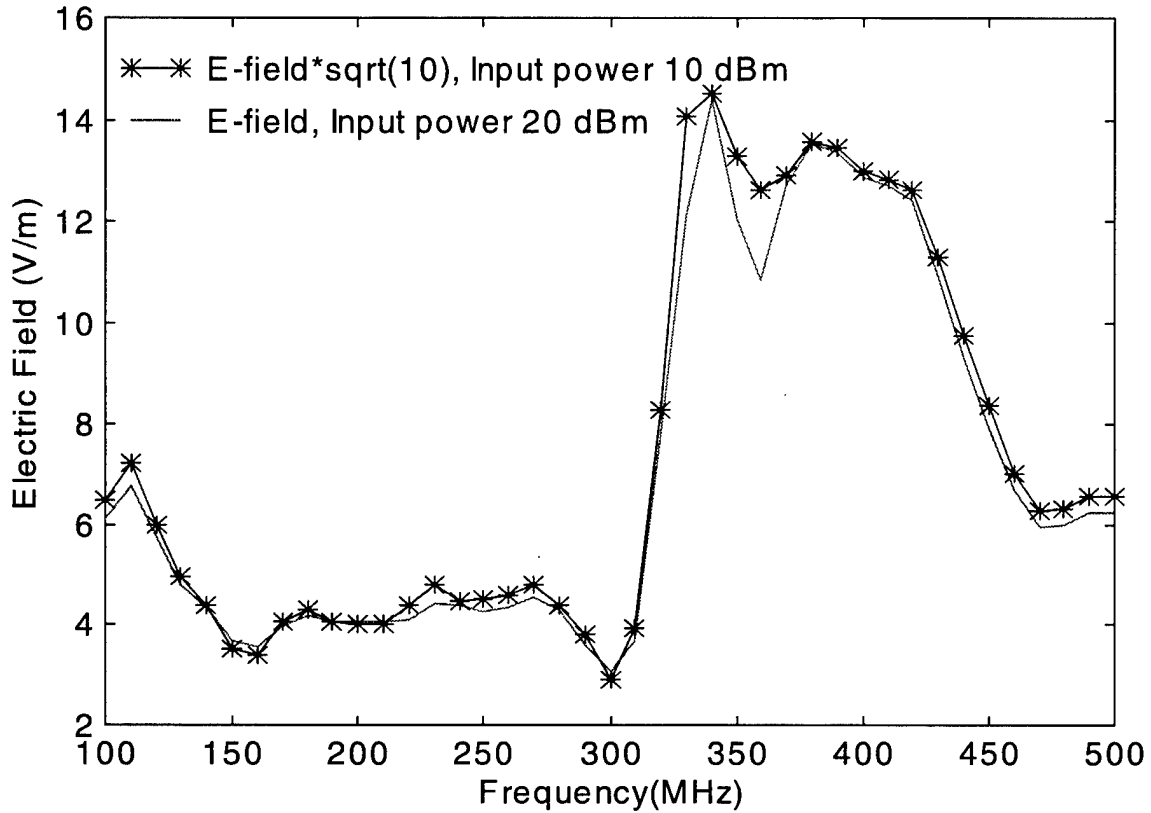

Figure 23. Comparison of electric fields measured near feed for Mark I vest antenna for two values of input power.

This power law relationship between the input power and measured electric field holds for many values of the input power. Figure 24 compares the measured electric fields scaled by the square root of the input power. These measurements were conducted at one frequency (250 MHz) and at one location (point C). The results were normalized so that the results coincided at an input power of 20 dBm. The power law relationship holds for many values of the input power.

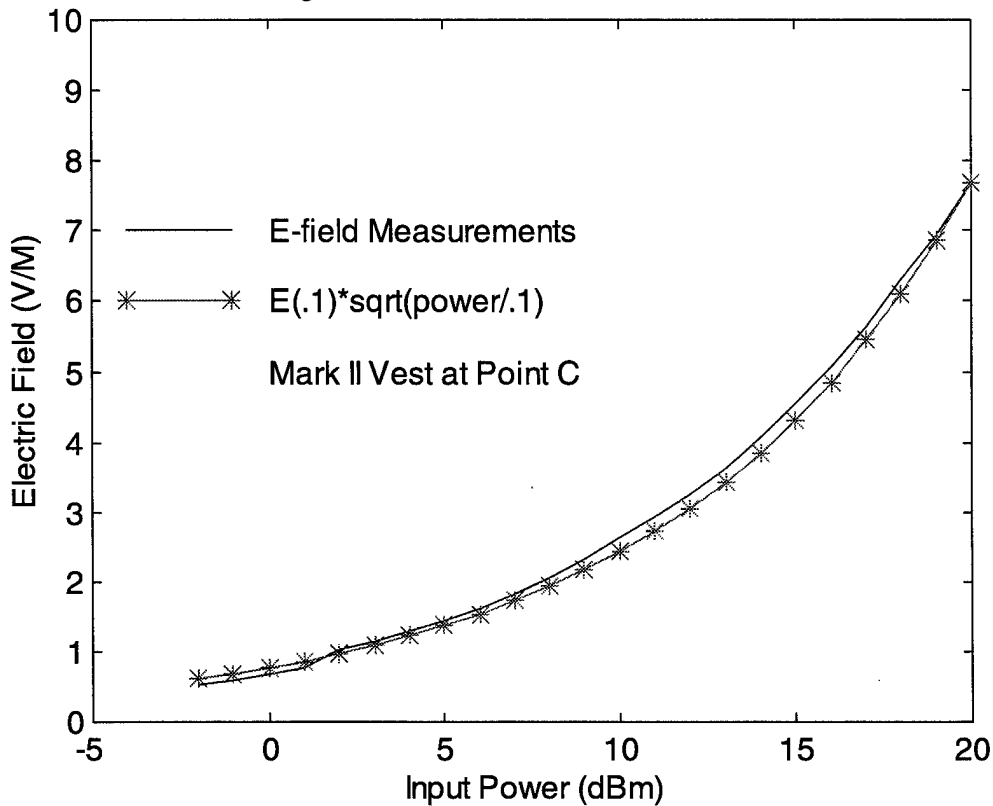

Figure 24. Scaled electric fields measured in Mark I vest antenna at one frequency at one location as a function of input power.

Verifying this relationship is important. To infer the result for an input power of 4 W from a measurement obtained at 0.1 W involves extrapolation, which is always dangerous. This result indicates that the procedure has some validity as long as no conductive body is present.

Figure 25 presents the measurements of the electric field versus frequency measured at various locations in the Mark I vest antenna. The input power from the signal generator was measured by using a bidirectional coupler (20 dB, nominally) and a Hewlett Packard power meter. There were many frequencies in which the full 20 dBm of power could not be input. The signal generator flashed a warning light for being unbalanced. At this frequency, the level of the input power was reduced. The results for the electric field were scaled so that there was 20 dBm of input power.

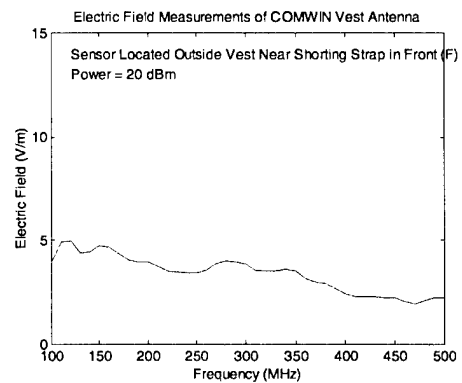
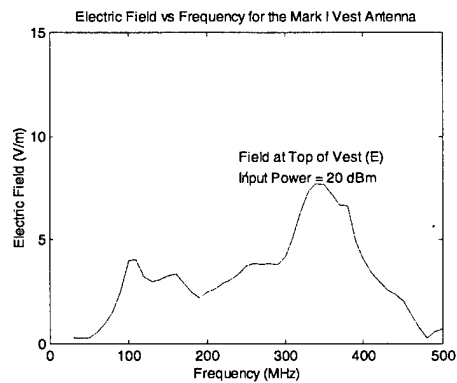
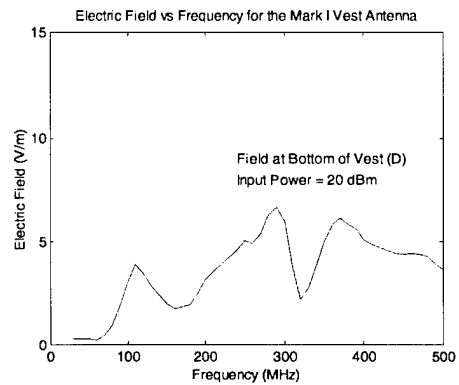
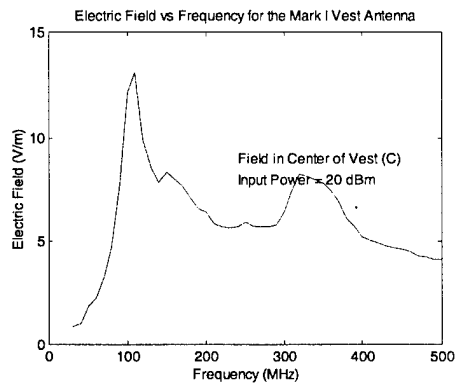
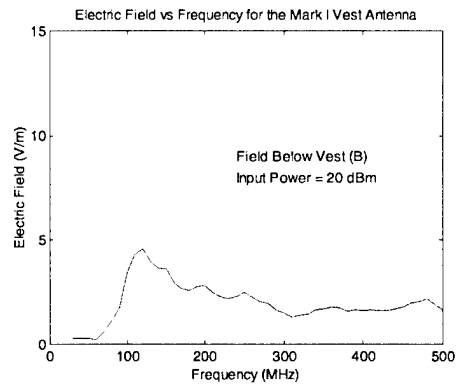
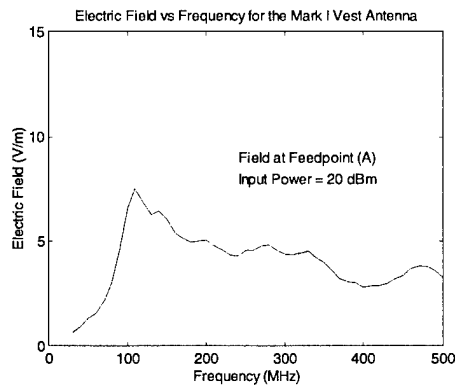

Figure 25. Electric fields measured at locations inside and outside Mark I vest antenna as a function of frequency.

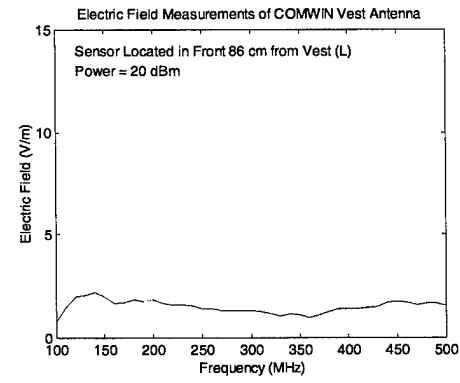
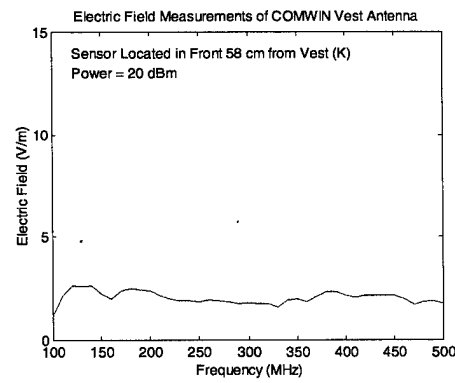
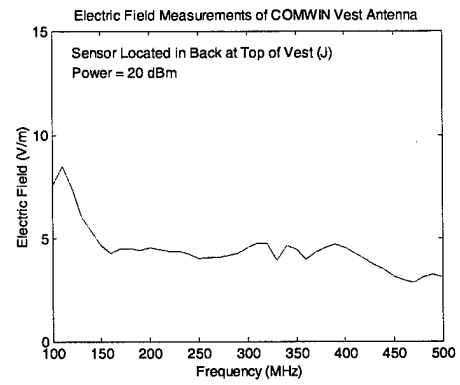
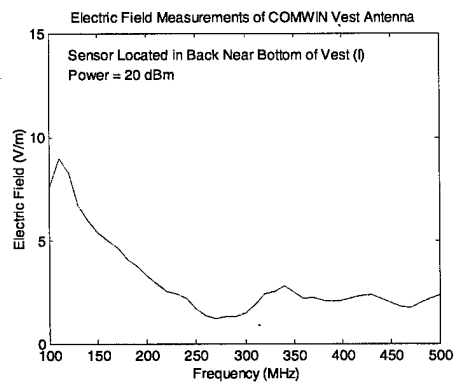
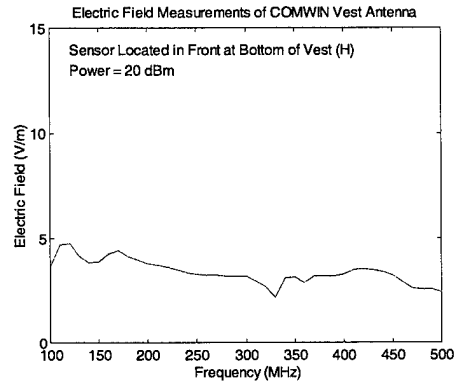
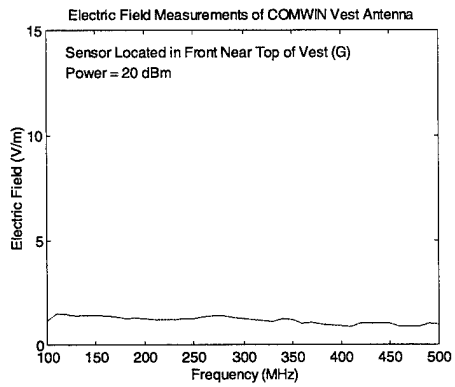

Figure 25 (continued). Electric fields measured at locations inside and outside Mark I vest antenna as a function of frequency.

The results for the measured electric field were then scaled to an input power of 4 W (multiplication by a factor of $\sqrt{40} = 6.3$). Figure 26 shows the results for the Mark I vest antenna.

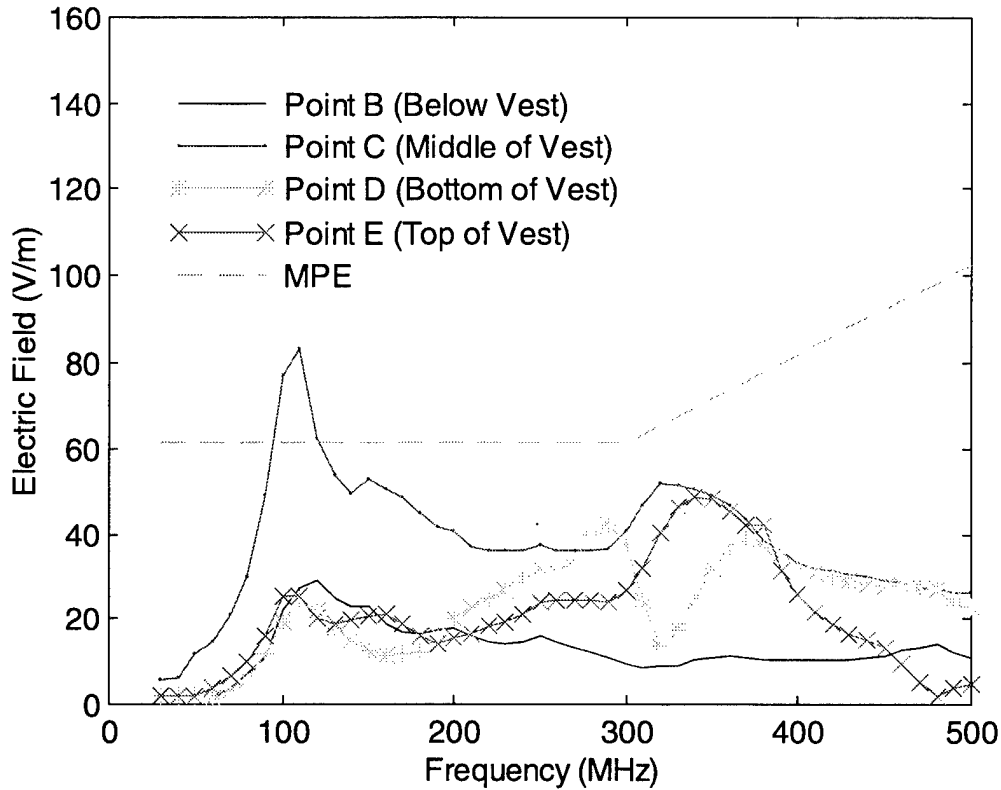

Figure 26. Electric fields measured inside Mark I vest antenna versus frequency for 4-W input power.

The MPE in terms of the electric field is plotted on the same curve. The electric field at the center of the vest antenna (point C just opposite the feed) is larger than the MPE in the frequency range from 90 to 120 MHz. For all other locations and frequencies, the scaled electric field is always less than the MPE. Because a 90- to 110-MHz frequency range is the commercial FM band, this result is probably not very serious.

Figures 27, 28, and 29 show a similar analysis for the Mark II vest antenna. Figure 27 pertains to the situation in which the Mark II is over a flak jacket. Figure 28 pertains to the Mark II alone. Figure 29 pertains to the use of the Mark I antenna as a shield for the person. The Mark II is over a flak jacket covering the Mark I. The power is input to the Mark II. For all cases, the result is scaled to an input power of 4 W.

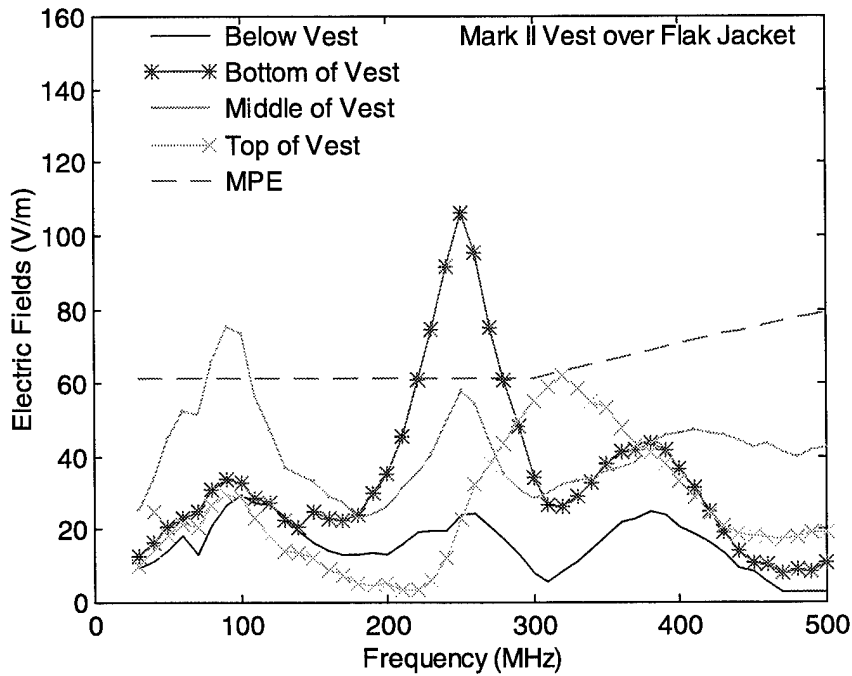

Figure 27. Electric fields measured inside Mark II vest antenna over flak jacket for four locations versus frequency.

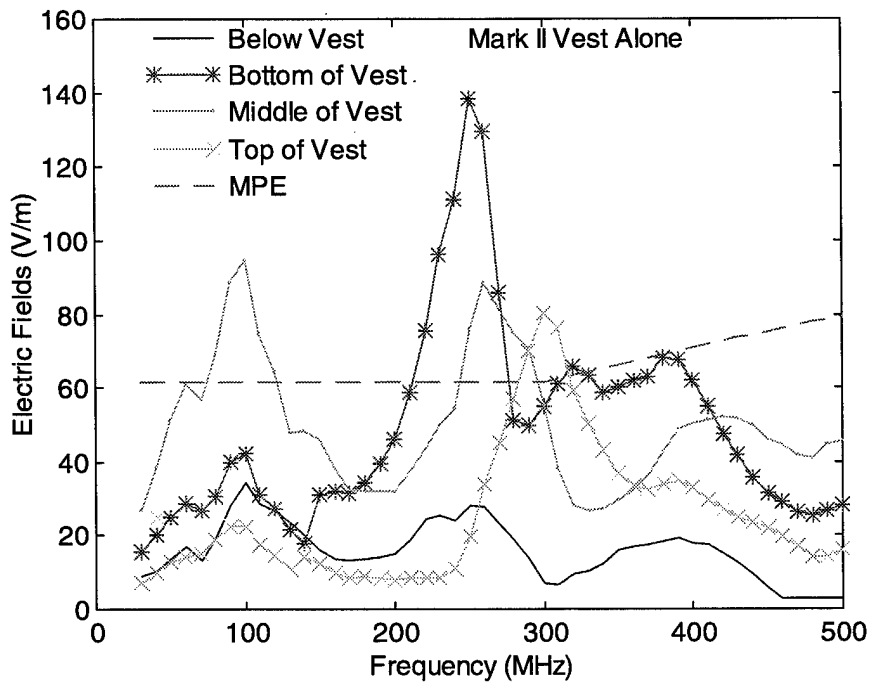

Figure 28. Electric fields measured inside Mark II vest antenna for four locations versus frequency.

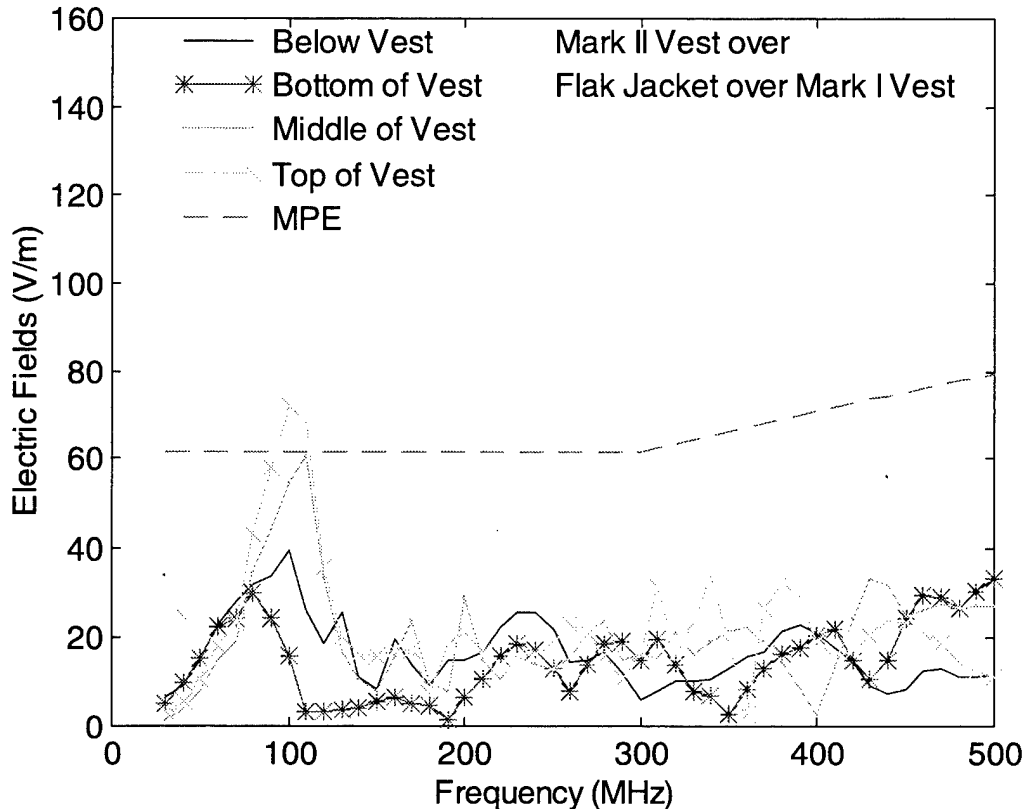

Figure 29. Electric fields measured inside Mark II vest over flak jacket over Mark I versus frequency.

At a frequency of 100 MHz for point E, at the top of the vest, the extrapolated field is larger than the MPE even for the case in which the Mark I vest antenna is used. Some sort of resonance is excited in the vest. This increase in field at 100 MHz was also present in the Mark I (figure 26). For the Mark II vest, there is also a major resonance at 270 MHz at the bottom of the vest (point D). The flak jacket reduces the field from approximately 140 V/m to 110 V/m. The flak jacket also reduces the fields at all other locations for this frequency to values below the MPE. The Mark I reduces the fields for frequencies above 100 MHz to values far below that of the MPE. The material of the Mark I can act as a shield.

The effect of a person inside the vest has a significant impact upon the distribution of fields and the radiation hazards. The conductive and dielectric properties of a person affect the impedance (figure 1). These properties also affect the fields themselves.

Helmet Antennas

The electric field was also measured for the Mark I and Mark II helmet antennas. Only a site that corresponds to the location of the head was used. Because of the lack of calibration of the probe for frequencies above 1000 MHz, the results were plotted only between 300 and 1000 MHz. Fields for frequencies higher than 1000 MHz were measured. The typical result was much less than that measured at the lower frequencies.

Figures 30 and 31 shows the measurement of electric field scaled to an input power of 100 mW (20 dBm) for the two helmet antennas for frequencies between 300 and 1000 MHz.

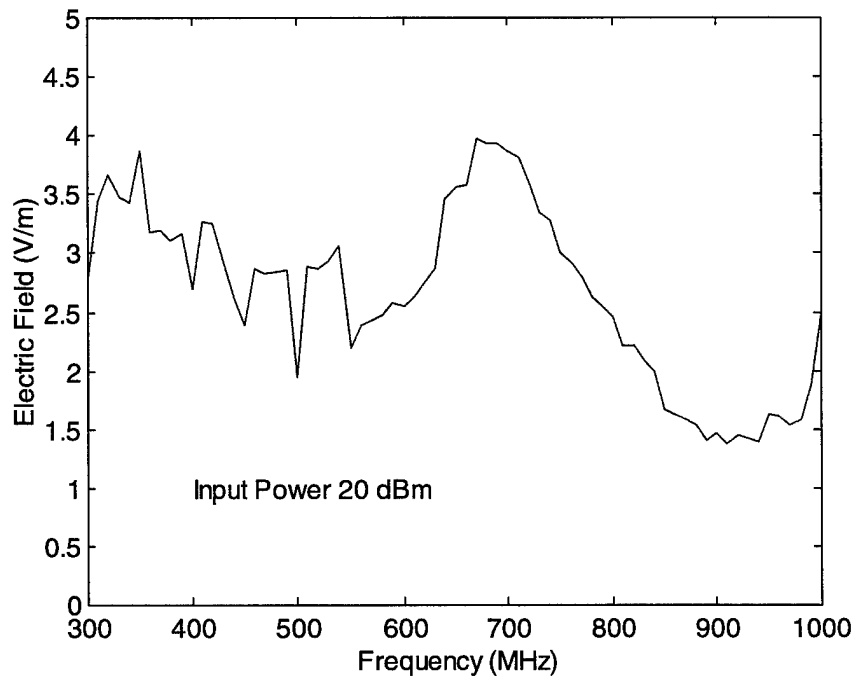

Figure 30. Electric field scaled to 20-dBm input power measured in Mark I helmet antenna versus frequency.

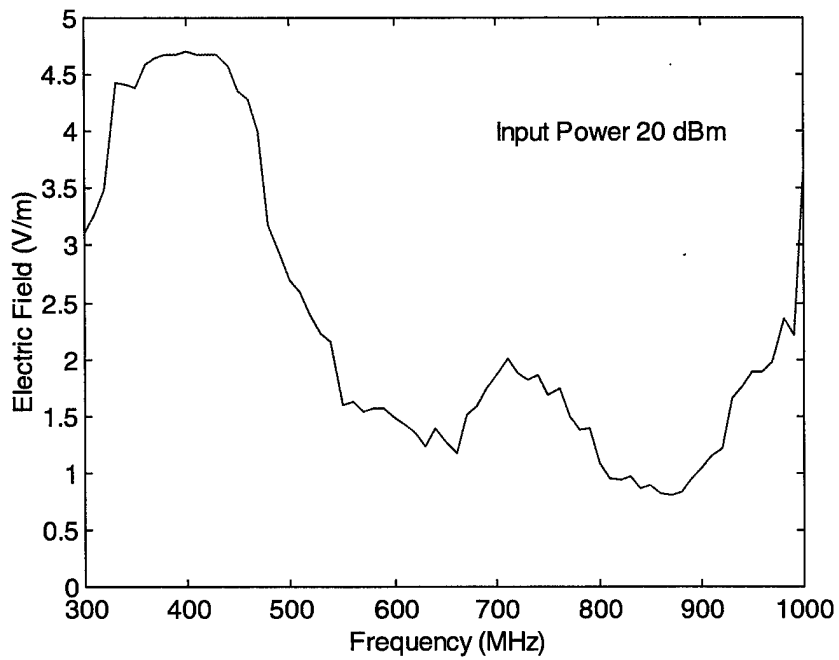

Figure 31. Electric field scaled to 20-dBm input power measured in Mark II helmet antenna versus frequency.

The electric fields in the Mark II helmet antenna are typically larger than those in the Mark I. Even when scaled to an input power of 4 W, the measured fields would still be less than those of the MPE. For frequencies higher than 1000 MHz, the fields decreased slowly with increasing frequency. There seems to be no reason to believe that the helmet antennas pose any radiation hazard.

SPECIFIC ABSORPTION RATE DETERMINATION

There is a large amount of literature concerning theoretical and experimental determination of the heating of a human body by electromagnetic fields. Much of this research discusses cell phones operating at 900 and 1800 MHz (Gandhi, Lazzi, and Furse, 1996). The typical procedure is to develop a theoretical model, often using finite difference, time domain methods for solving Maxwell's equations. The average dielectric and conductivity distributions of the body are known. (The University of Utah developed this model by freezing a corpse and slicing the "corpsesicle" into small sections to analyze the results.) The calculation then predicts the electric field inside the conducting body. The product of the conductivity and the absolute square of the electric field is equal to the Joule heating per unit volume. Division by the mass density results in determination of the specific absorption rate (SAR), which is the amount of heating per unit mass. The maximum SAR is 0.4 W/kg in a controlled area for a whole body. This value can increase to 8 W/kg for a 1-gram cube because of the cooling effects of blood flow. The averaging time is usually 6 minutes for the measurement of the SAR.

Experimentally, the procedure for determining the SAR is to expose the body to electromagnetic fields for a prescribed amount of time. The body has a mixture that simulates the dielectric and conductive properties of a human in the appropriate frequency range. The measurement of the loss of energy by the body, after exposure to the electromagnetic fields is discontinued, then allows determination of the total energy absorbed. The method for measuring this heat loss sometimes involves putting the body and a control into calorimeters and allowing the two bodies to come into thermal equilibrium after periods lasting as long as 48 hours (Olsen and Griner, 1989, 1993). Dr. Olsen has patented this technique (Olsen, 1988). A second method uses point thermal sensors to measure the rise in temperature in a localized area (Olsen and Bowman, 1989). Knowledge of the specific heat of the body and the rise in temperature allows measurement of the SAR. We will use a variant of this method for measuring the absorption of electromagnetic energy.

Before we fabricated a substance that simulates the dielectric and conductive properties of a human, we thought it prudent to develop experimental procedures on a purely salt solution. The generation of heat is caused by the conductivity of the salt in solution (a human has a conductivity of approximately one-quarter that of seawater). A purely salt solution will do much to allow an assessment of the heating of a body by the Mark I vest antenna.

The Mark I vest antenna described by Adams et al. (1999) was limited in power that could be radiated by the introduction of a RF transformer. Although the transformer made the antenna efficient, this device could handle a maximum of 0.25 W. The transformer was replaced by a matching circuit composed of an inductor and capacitor that could stand high power (at least 50 W) while providing acceptable matching in a limited frequency range.

Our goal is to input 50 W (47 dBm) and measure the rise in temperature of a salt solution. In performing this experiment, we will develop procedures for performing the more realistic case.

We mixed 737 g of salt with 34 liters of tap water and allowed the mixture to sit for several days. The saltwater was completely enclosed by a plastic trash can and a plastic trash bag on the top to prevent evaporation. We measured the temperature of the water (22°C). We estimated the conductiv-

ivity of the water as 1.4 S/m based upon a formula given by the web site for the Johns Hopkins University Applied Physics Laboratory (John Hopkins University Applied Physics Laboratory, 2000). We then used a HP 8510 C network analyzer to measure the VSWR of the Mark I vest antenna over the salt solution. Figure 32 presents the VSWR versus frequency for this case.

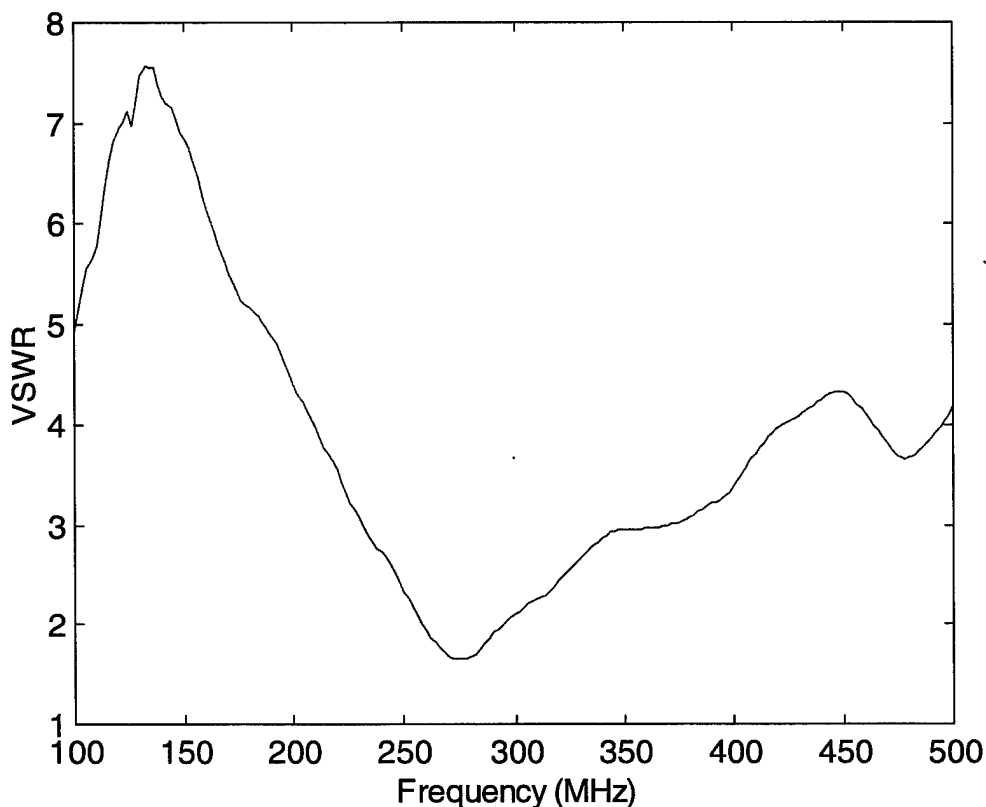

Figure 32. VSWR versus frequency for Mark I vest antenna surrounding a saltwater solution.

For frequencies between 230 and 360 MHz, the measured VSWR of the antenna was better than 3:1. We then attached the signal generator to a 50-dB power amplifier. The output of the power amplifier was connected to a bidirectional coupler. One coupler port was connected to a power meter. The other port was connected to a spectrum analyzer to measure the power returned to the amplifier. The output of the coupler was connected to the antenna. A total power of 47 dBm, as determined by the power meter, was input to the antenna. Many experiments were conducted. The water temperature was measured at 1, 3, 6, and 30 minutes. No increase in temperature was observed. We conducted a 30-minute exposure of the saltwater at frequencies of 250, 300, and 350 MHz. Again, no increase in temperature was observed. We used the NARDA 8631 to measure the magnetic field near the feed. The fields were far in excess of the MPE at distances less than 1 meter from the feed.

We then covered the NARDA probe with a plastic trash bag to protect it and dipped it into the saltwater. The power input to the vest was 20 dBm. The fields near the feed were measured at a frequency of 300 MHz and found smaller than those in figure 25. The fields in most salt solutions were very small. The outer portion of the salt solution had shielded the majority from the fields and prevented heat generation.

The lack of rise in temperature provides an estimate of the upper bound for the average electric field in saltwater. Assuming that the conductivity of the water was 1.4 S/m and the rise in temperature was less than 0.1°C for a period of 1800 s, the average electric field was less than 13 V/m. The total volume of the water was 0.034 m³. The specific heat was assumed to be 4180 J/°C kg. This is a factor of 4.5 less than the maximum permissible exposure.

Jell Fabrication

To understand the interaction of a person with electromagnetic fields, a substance with the appropriate dielectric and conductive properties must be developed. No one substance can represent these properties over the entire frequency range. Because of the result in the previous section, we will confine our investigation to the 200- to 400-MHz range. Chou et al. (1984) presented a recipe for making the jell for certain frequency bands. For frequencies less than 100 MHz, the recipe included aluminum powder that can be inflammable. The ingredients for the jell for frequencies higher than 100 MHz are water, salt, TX-151, and polyolefin. The TX-151, developed by Oil Center Research in Midland, TX, is a petroleum product designed to solidify upon the addition of water. The polyolefin modifies the dielectric constant of the resulting fluid. The salt provides conductivity. Table 1 presents the recipes for fabricating the jell for different frequencies, reproduced from Chou's paper.

Table 1. Dielectric and conductive properties of jell with compositions that depend on frequency.

Freq. (MHz)	Dielectric Constant Person	Conductivity Person (S/m)	Dielectric Constant Jell	Conductivity (S/m) Jell	TX-151 (%)	Polyolefin Powder (%)	Aluminum Powder (%)	Water (%)	Salt (%)
2450	47.0	2.17	47.4±0.9	2.17 ±0.08	8.46	15.01	-----	75.48	1.051
915	51.0	1.28	51.1±0.6	1.27 ±0.02	8.42	15.44	-----	75.15	0.996
750	52.0	1.25	52.5±0.6	1.26 ±0.04	8.42	15.44	-----	75.15	0.996
433	53.0	1.18	53.5±0.5	1.21 ±0.01	8.42	15.44	-----	75.15	0.996
300	54.0	1.15	54.8±0.7	1.17 ±0.01	8.42	15.44	-----	75.15	0.996
200	56.5	1.00	56.7±0.7	1.06 ±0.02	8.39	15.79	-----	74.92	0.894
100	71.7	0.89	71.5±1.1	0.89 ±0.01	9.81	-----	2.12	87.59	0.482
70	84.0	0.79	84.7±0.5	0.76 ±0.01	10.36	-----	2.72	86.50	0.424
40.68	97.0	0.68	97.9±3.8	0.70 ±0.02	9.68	-----	9.20	80.82	0.303
27.12	113.0	0.60	113±3.0	0.62 ±0.02	9.70	-----	9.06	80.97	0.270
13.56	149.0	0.62	149±3.0	0.62 ±0.03	9.69	-----	9.15	80.88	0.280

Numerous small batches of the jell were mixed. The usual result was a mess of "gloop" with small polyolefin balls mixed in. Eventually, the proper mix of original temperature of water (very cold so that the mixture did not solidify so rapidly), mixing time, and rotation speed on a drill provided a good mixture without air bubbles. The consistency was that of cake batter. The liquid was poured into a plexiglass container with electrodes at the end. The jell solidified within minutes. The shape was rectangular parallelepiped. The width was 0.1 m; the length was 0.2 m. The total height of either electrode was 0.1 m. The height of the liquid was 0.1 m. When we attempted to measure the DC resistance, we found that the application of any voltage caused electrolysis of the liquid. To measure the resistance, we used an LCR meter (model 4274A manufactured by Hewlett Packard). Operating at a frequency of 1000 Hz, the measurement of resistance did not change with time. The reading of the LCR meter was 18.7 ohms, resulting in a conductivity of 1.07 S/m. This measurement compares to the 1.17 S/m for Chou's fluid.

An inhomogeneous jell was fabricated. The percentage of water, TX-151, and polyolefin was constant. The amount of salt varied. The conductivity of the three other types of jell was 0.54, 0.78, and 0.94 S/m, respectively. Approximately 8300 g of each type of material was mixed in the usual fashion. The composition filled a closed plastic container that allowed the stacking of material. These containers sat on the 34 l container whose conductivity was 1.07 S/m.

Results

The jell was made of 25.55 kg of water, 2.86 kg of TX-151, 5.25 kg of polyolefin, and 0.34 kg of salt. The container was made of plastic (a 34-liter trash can). The jell was allowed to sit overnight so that its temperature was approximately equal to room temperature. The Mark I vest antenna was draped over the container. A Hewlett Packard 8510C network analyzer determined the VSWR of the vest over the jell and the frequency of maximum transmitted power. At a frequency of 250 MHz, 50 W of power was input to the vest for 30 minutes. Figure 33 compares the VSWR and the impedance versus frequency of the Mark I vest antenna for the jell and a person. The agreement was fairly good for frequencies between 100 and 320 MHz.

In the late afternoon of 1 September 2000, we conducted an experiment to assess the radiation hazard of the Mark I vest antenna. Power was input into the Mark I vest antenna with the jell inside. Because the VSWR of the Mark I vest antenna had a minimum of 3:1 at 250 MHz, we used this frequency. (We had developed the matching circuit to optimize the 100 to 500 MHz VSWR for the Mark I vest antenna over a Styrofoam model.) The output power as measured on the power meter was 36 dBm. This power was held constant for 30 minutes. Before the power was turned on, the temperature of the jell was 19.1°C. After 30 minutes, the temperature was 19.5°C. The ambient temperature inside the shed was 24°C. The specific heat of the jell was approximately 3600 J/(kg-C) (a guess based on Leonard et al., 1984). The 34 kg of jell absorbed approximately 49000 J of energy in the 1800 s of operation. This measurement corresponds to a specific absorption rate of 0.8 W/kg.

The electric field was measured outside the vest. At a distance of approximately 0.2 m in front, 0.2 m to the right of the center, and 0.44 m below the center of the vest, the electric field was measured as 3.2 V/m. A NARDA magnetic field probe (model 8631) very near the feed measured a field of 5 mW/cm². This power density corresponds to a magnetic field strength of 0.36 A/m.

The experiment was repeated in the early mornings of 5 and 6 September 2000. On 5 September, the ambient temperature of the shed was 23.2°C compared to 23.0°C for the jell. A total of 40 dBm was input into the vest antenna for 38 minutes. The temperature of the jell was exactly what

it was previously. The input power was increased to 40.7 dBm. After 30 minutes, the temperature of the jell was measured at 23.0°C.

On 6 September, the input was increased to 46 dBm. The measured electric field increased to 12.06 V/m outside the vest. The ambient temperature was 21.3°C. The initial temperature of the jell was 23.1°C. After 30 minutes, the ambient temperature had increased to 21.9°C, but the temperature of the jell remained fixed at 23.1°C.

During the afternoon of 6 September, the inhomogeneous jell was used as the model. The plastic containers with the differing conductivity were stacked on the 34 l container. The conductivity was arranged to decrease with increasing height. Again, there was no increase in the temperature of the jell even after 50 W of input power for 30 minutes.

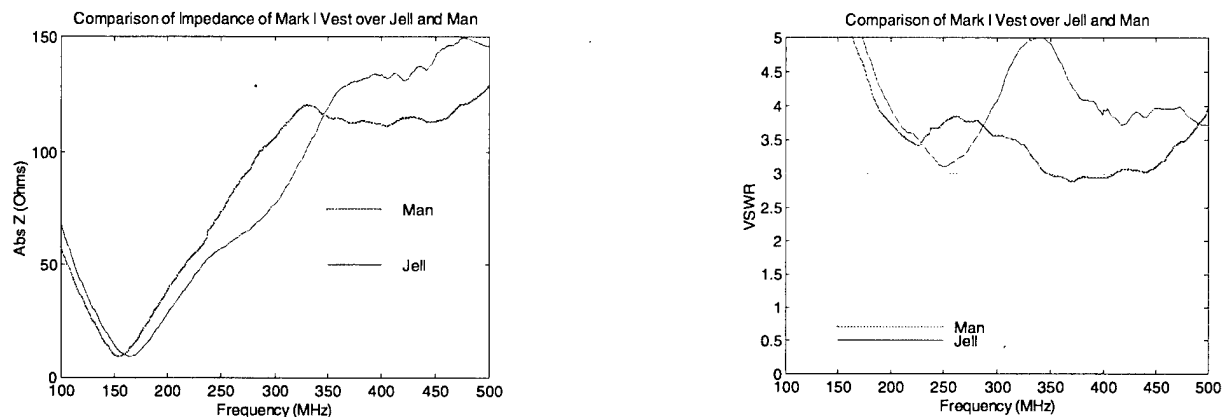

Figure 33. Comparison of VSWR and Mark I vest antenna impedance surrounding jell and a person.

THEORY

Many theoretical predictions of the heating of the human body by electromagnetic fields have been reported in the technical literature. The popularity of cell phones and the controversy over their radiation hazards are two reasons that many papers have been published on this topic during the past 10 years.

The most frequently used method for treating the interaction between humans and electromagnetic fields has been that of Finite Difference Time Domain (FDTD). This method solves the vector Maxwell's equations (i.e., Faraday's law and Ampere's law with displacement current) as an initial value problem. The divergence equations are automatically satisfied. The spatial derivatives are approximated as a central finite difference. Regions with spatially inhomogeneous dielectric and conductive properties are treated in a straightforward manner. If the substance within the region has dispersion (i.e., the dielectric constant depends upon frequency), the FDTD method has great difficulty. The method solves Maxwell's equations in the time domain. Large amounts of storage are required for significant problems (Taflove, 1995).

A second technique, used infrequently in problems for radiation hazards, is the method of moments. This method approximates the dependence of the current within a conductor upon space in a simple way and solves for the amplitudes of the currents with the imposition of boundary conditions. Recently, SSC San Diego, Lawrence Livermore National Laboratory, Ohio State University, and other organizations have upgraded the method of moments to treat different types of

substances. The code called EIGER can solve the problem of the interaction of humans with electromagnetic fields. Properties such as dispersion can be treated in a straightforward manner. Typically, a supercomputer is necessary to invert large sparse matrices. The method of moments works best if the radiating element is electrically small (i.e., if the wavelength is large compared to any length). If this condition is violated, the matrices become too large for present computers. The code, GNEC, also uses the method of moments. The prediction of the Mark I vest antenna impedance versus frequency was validated during FY 1999 (Adams et al., 1999).

A third technique uses the Geometric Theory of Diffraction (GTD). The code, Numerical Electromagnetic Code-Basic Scattering Code developed by Ohio State University among other organizations, treats electromagnetic fields as a collection of rays. The method is best suited if the wavelength of the electromagnetic field is smaller than any other length. The higher the frequency, the more accurate the result. The code can not handle substances with dielectric materials or imperfect conductors. Although the GTD is valid only at the highest frequencies, the method "degrades gracefully."

Models

Models of the electromagnetic fields were constructed using FDTD, EIGER, GNEC, and the NEC-BSC computer codes. The model using FDTD was completely unsuccessful because of a lack of time for formulating the proper input. EIGER compared the fields in a person with those in air. The model of the vest was very sophisticated. The GNEC work used the validated model for the Mark I vest antenna modified to calculate the internal electric and magnetic fields. The model using NEC-BSC computed the fields inside an empty vest. The vest was crudely modeled as a series of rectangular plates with holes for the head and arms. The feed was modeled as a dipole.

Comparison of Theory and Experiment

The NEC-BSC provided theoretical predictions of the electromagnetic fields inside the Mark I vest antenna. Figure 34 presents a comparison of the predicted and measured fields at four locations inside the vest as a function of frequency. Although the ratio of the theory to experiment can be as large as 2, the trends are treated well by the GTD method. Usually, the NEC-BSC predicts a field that is too large.

The theoretical results from GNEC and EIGER predicted electric fields too small by factors of 20 to 100 compared to those experimentally determined. The measurement was done too close to the source to make comparisons. Further research is necessary to understand this discrepancy fully.

Figure 35 shows the prediction by EIGER of the field in air to those in saltwater in the center of the vest. The dependent variable is the height above the floor. The height of the feed is marked. EIGER predicts that the field in the saltwater will be much smaller than that in air. This prediction was confirmed by the measurement by the NARDA probe and by the lack of rise in temperature versus time.

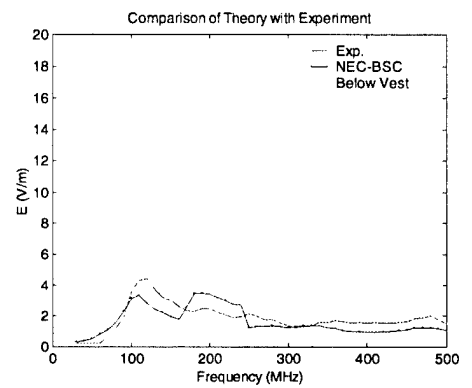
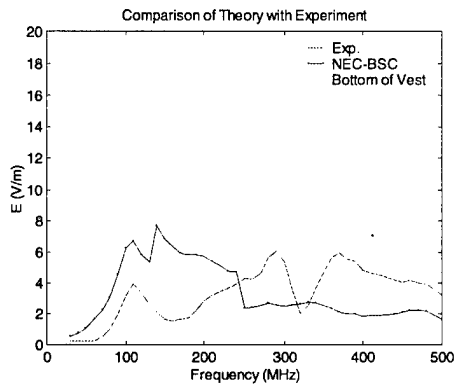
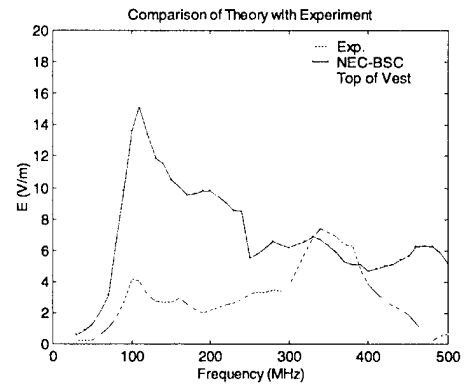
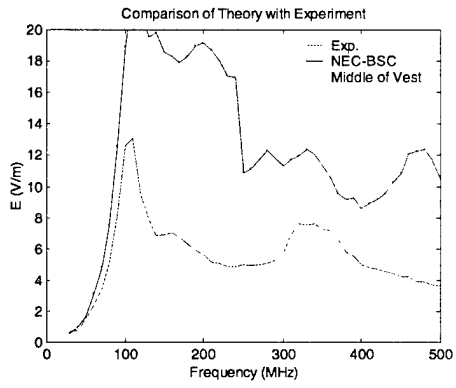

Figure 34. Predicted and measured electromagnetic fields inside Mark I vest antenna as a function of frequency.

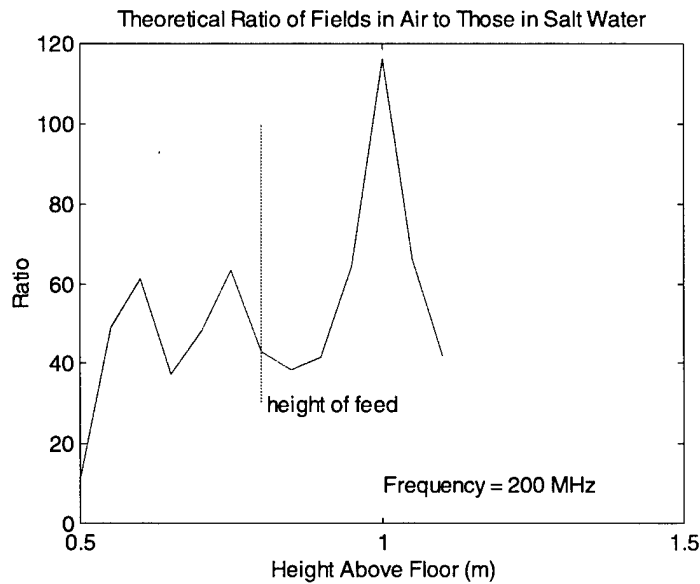

Figure 35. Predicted ratio of fields in air to those in saltwater.

ANALYSIS

Many measurements have been made of the electric field under various conditions of frequency, power, and location for the Mark I and Mark II vest antennas. The flak jacket has a moderating influence, but does not greatly affect the distribution of fields. The Mark I has a smaller internal electric field than that of the Mark II. When the Mark I vest antenna is used as a shield, the internal electric field of the Mark II becomes very small except at 90 MHz. This result provides one method of ensuring that the internal electric field meets the radiation hazard standards.

The usually null result from the measurement of the specific absorption rate for the Mark I vest antenna is very heartening. Clearly large amounts of energy were going into the Mark I vest antenna. These fields were radiated as electric and magnetic fields. Nonetheless, none of the fields heated the jell. Even after 30 minutes and 50 W of power, none of the jell was heated in four of the five experiments.

The use of 34 kg of jell in the form of a torso is actually a severe test of heating. All the jell is very close to the radiating element. If a whole body were used, the field at the feet would be small. The SAR would be minimized by the inclusion of parts of the body not affected by the fields.

CONCLUSIONS

The COMWIN antenna system shows great promise for providing a solution to two pressing problems of marines and soldiers. The first problem is to disguise the identity of the radio operator. The second problem is to provide broadband operation that is compatible with the Joint Tactical Radio. Although the antenna system has certain deficiencies when meeting the very stringent requirements imposed, the COMWIN meets most requirements. These requirements include those of VSWR versus frequency, gain, patterns, and radiation hazard.

There are still significant nulls in the pattern of the vest antenna as the frequency increases from 250 MHz. There are always nulls in the pattern of the helmet antenna throughout its range from 500 to 2000 MHz. The gain of the vest and the helmet antennas are unacceptably low as the frequency decreases. Although the internal electric field can be higher than those permitted at certain frequencies and at certain locations for input powers as high as 4 W, there is a null result in heating fluids within the vest with input power as high as 50 W. The presence of a person with a distribution of conductivity and dielectric material affects the fields in a complicated way. The result minimizes the heating of the interior of the person.

The Mark II with its saw-toothed design for the gap represents a significant departure from the straight gap of the Mark I. To a large extent, the Mark I has many advantages in efficiency and patterns. The experience gained in the testing of the Mark II will go far towards permitting the next model to meet the requirements.

REFERENCES

- Adams, R. C., P. Haglind, H. Pace, J. Lebaric, R. Adler, T. M. Gainor, and A. T. Tan. 1999. "FY99 Feasibility Study on COMWIN Antenna System." TD 1808 (Nov). SSC San Diego, CA..
- Chou, Chung-Kwang, Gang-Wu Chen, A. W. Guy, and K. H. Luk. 1984. "Formulas for Preparing Phantom Muscle Tissue at Various Radiofrequencies," *Bioelectromagnetics*, vol. 5, pp. 435-441.
- Department of Defense. 1995. DOD I 6055.11 (21 Feb). Washington, DC.
- Department of the Navy. 1999. OPNAVINST 5100.23E (15 Jan), "Non-Ionizing Radiation." Chapter 22 in *Navy Occupation and Health Program Manual*, Washington, D.C.
- Gandhi, O. P., G. Lazzi, and C. M. Furse. 1984. "Electromagnetic Absorption in the Human Head and Neck for Mobile Telephones at 835 and 1900 MHz," *IEEE Transactions on Microwave Theory and Techniques*, vol. 44, no. 10 (Oct), p. 1884.
- Institute of Electronic and Electrical Engineers. 1992. *IEEE Standard for Safety Levels with Respect to Human Exposure to Radio Frequency Electromagnetic Fields, 3 kHz to 300 GHz*. IEEE C95.1-1991 (27 Apr).
- John Hopkins University Applied Physics Laboratory. 2000. "A Sea Water Equation of State Calculator." Web site: <http://fermi.jhuapl.edu/denscalc.html>
- Leonard, J. B., K. R. Foster, and T. W. Athey. 1984. "Thermal Properties of Tissue Equivalent Phantom Materials," *IEEE Transactions on Biomedical Engineering*, vol. BME-31, no. 7 (Jul), p. 533.
- Olsen, R. G. 1988. "Near-Field Radio Wave Dosimetry," U.S. Patent 4,813,789, Filed August 1, 1988.
- Olsen, R. G. and R. R. Bowman. 1989. "Simple Nonperturbing Temperature Probe for Microwave/Radiofrequency Dosimetry," *Bioelectromagnetics*, vol. 10, pp. 208-213.
- Olsen, R. G. and T. A. Griner. 1989. "Outdoor Measurement of SAR in a Full-Sized Human Model Exposed to 29.9 MHz in the Near Field," *Bioelectromagnetics*, vol. 10, pp. 161-171.
- Olsen, R. G. and T. A. Griner. 1993. "Specific Absorption Rate and Radiofrequency Current-to-Ground in Human Models Exposed to Near-Field Irradiation," *Health Physics*, vol. 64, no. 6 (Jun), p. 633.
- Taflove, A. 1995. *Computational Electrodynamics: The Finite-Difference, Time-Domain Method*, Artech House, Norwood, MA.

REPORT DOCUMENTATION PAGE

Form Approved
OMB No. 0704-01-0188

The public reporting burden for this collection of information is estimated to average 1 hour per response, including the time for reviewing instructions, searching existing data sources, gathering and maintaining the data needed, and completing and reviewing the collection of information. Send comments regarding this burden estimate or any other aspect of this collection of information, including suggestions for reducing the burden to Department of Defense, Washington Headquarters Services Directorate for Information Operations and Reports (0704-0188), 1215 Jefferson Davis Highway, Suite 1204, Arlington VA 22202-4302. Respondents should be aware that notwithstanding any other provision of law, no person shall be subject to any penalty for failing to comply with a collection of information if it does not display a currently valid OMB control number.

PLEASE DO NOT RETURN YOUR FORM TO THE ABOVE ADDRESS.

1. REPORT DATE (DD-MM-YYYY) 09-2000		2. REPORT TYPE Technical		3. DATES COVERED (From - To)	
4. TITLE AND SUBTITLE COMWIN ANTENNA SYSTEM FISCAL YEAR 2000 REPORT				5a. CONTRACT NUMBER	
				5b. GRANT NUMBER	
				5c. PROGRAM ELEMENT NUMBER 0602131M	
6. AUTHORS R. C. Adams, R. S. Abramo, J. L. Parra, J. F. Moore				5d. PROJECT NUMBER	
				5e. TASK NUMBER	
				5f. WORK UNIT NUMBER	
7. PERFORMING ORGANIZATION NAME(S) AND ADDRESS(ES) SSC San Diego San Diego, CA 92152-5001				8. PERFORMING ORGANIZATION REPORT NUMBER TR 1836	
9. SPONSORING/MONITORING AGENCY NAME(S) AND ADDRESS(ES) Chief of Naval Research Ballston Centre Tower 1 800 North Quincy Street Arlington, VA 22217-5660				10. SPONSOR/MONITOR'S ACRONYM(S)	
				11. SPONSOR/MONITOR'S REPORT NUMBER(S)	
12. DISTRIBUTION/AVAILABILITY STATEMENT Approved for public release; distribution is unlimited.					
13. SUPPLEMENTARY NOTES					
14. ABSTRACT The project to develop a broadband, man-carried antenna began in May 1999. There were two objectives. The first objective was to develop an antenna system whose visual signature did not distinguish the radio operator from any other soldier. The solution to this first objective was to integrate the antenna into the uniform of the soldier. Hence, the project is COMbat Wear Integration (COMWIN). The second objective was to fabricate an antenna that could transmit or receive at any frequency between 2 MHz and 2GHz. The Joint Tactical Radio (JTR) requires this frequency. The figure of merit to determine whether the radio is efficient in the band is a Standing Wave Ratio (VSWR) of less than 3:1. The COMWIN antenna system would consist of three antennas. The first antenna, in the form of a vest, would operate in the 30- to 500-MHz band. The helmet antenna would operate in the 500- to 2000-MHz band. An antenna that runs down the edges would operate in the 2- to 30-MHz band.					
15. SUBJECT TERMS Mission Area: Command, Control, and Communications decision support amphibious assault man-carried antenna tactical command center broadband					
16. SECURITY CLASSIFICATION OF:			17. LIMITATION OF ABSTRACT	18. NUMBER OF PAGES	19a. NAME OF RESPONSIBLE PERSON
a. REPORT	b. ABSTRACT	c. THIS PAGE			R. C. Adams
U	U	U	UU	72	19b. TELEPHONE NUMBER (Include area code) (619) 553-4313

INITIAL DISTRIBUTION

D0012	Patent Counsel	(1)
D0271	Archive/Stock	(6)
D0274	Library	(2)
D027	M. E. Cathcart	(1)
D0271	D. Richter	(1)
D383	J. Moore	(2)
D12	USMC Office	(5)
D653	CW03 F. V. Canez	(1)
D841	R. C. North	(1)
D841	LCDR H. Pace, Jr.	(1)
D85	C. Sayre	(1)
D855	R. C. Adams	(6)
D855	C. Hendrickson	(1)
D855	J. Parra	(2)
D856	R. Abramo	(2)
D87	LCDR C. Wrightson	(1)
J323	K. Khalil	(1)

Defense Technical Information Center
Fort Belvoir, VA 22060-6218 (4)

SSC San Diego Liaison Office
Arlington, VA 22202-4804

Center for Naval Analyses
Alexandria, VA 22302-0268

Office of Naval Research
Attn: NARDIC (Code 362)
Arlington, VA 22217-5660

Government-Industry Data Exchange
Program Operations Center
Corona, CA 91718-8000

Office of Naval Research
Arlington, VA 22217-5660 (7)

Space and Naval Warfare Systems Command
San Diego, CA 92110-3127

Marine Corps Warfighting Lab
Quantico, VA 22134

Marine Corps Systems Command
Quantico, VA 22134-5080