

LOAN DOCUMENT

PHOTOGRAPH THIS SHEET

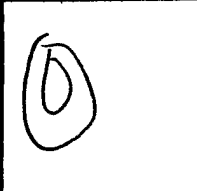

INVENTORY

DTIC ACCESSION NUMBER



LEVEL

Operations and Maintenance Manual . . .

DOCUMENT IDENTIFICATION

Nov 94

DISTRIBUTION STATEMENT A

Approved for Public Release
Distribution Unlimited

DISTRIBUTION STATEMENT

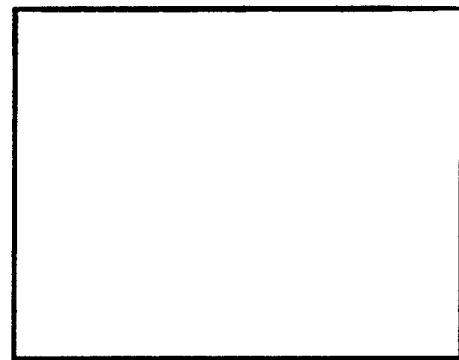

DATE ACCESSIONED



DATE RETURNED

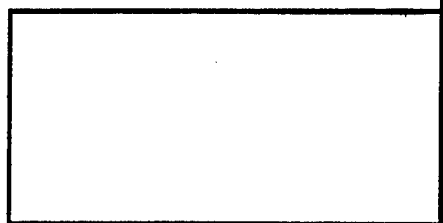

REGISTERED OR CERTIFIED NUMBER

ACCESSION FOR	
NTIS	CRAB
DTIC	TRAC
UNANNOUNCED	
JUSTIFICATION	
BY	
DISTRIBUTION/	
AVAILABILITY CODES	
DISTRIBUTION	AVAILABILITY AND/OR SPECIAL
A-1	

DISTRIBUTION STAMP

20001208 017

DATE RECEIVED IN DTIC

PHOTOGRAPH THIS SHEET AND RETURN TO DTIC-FDAC

H
A
N
D
L
E

W
I
T
H

C
A
R
E

**Operations and Maintenance Manual for the
Full-Scale Bioventing System at
POL Yard, Sites SS-06 and ST-40**



**Wurtsmith Air Force Base
Michigan**

Prepared For

**Air Force Center for Environmental Excellence
Brooks Air Force Base
San Antonio, Texas**

and

**Air Force Base Conversion Agency/OL-T
Oscoda, Michigan**

November 1996

 **PARSONS
ENGINEERING SCIENCE, INC.**

1700 Broadway, Suite 900 • Denver, Colorado 80290

AQ M01-02-0400

DEFENSE TECHNICAL INFORMATION CENTER REQUEST FOR SCIENTIFIC AND TECHNICAL REPORTS

Title AFCEE Collection

1. Report Availability (Please check one box)

- This report is available. Complete sections 2a - 2f.
- This report is not available. Complete section 3.

2a. Number of Copies Forwarded

1 each

2b. Forwarding Date

July/2000

2c. Distribution Statement (Please check ONE box)

DoD Directive 5230.24, "Distribution Statements on Technical Documents," 18 Mar 87, contains seven distribution statements, as described briefly below. Technical documents MUST be assigned a distribution statement.

- DISTRIBUTION STATEMENT A: Approved for public release. Distribution is unlimited.
- DISTRIBUTION STATEMENT B: Distribution authorized to U.S. Government Agencies only.
- DISTRIBUTION STATEMENT C: Distribution authorized to U.S. Government Agencies and their contractors.
- DISTRIBUTION STATEMENT D: Distribution authorized to U.S. Department of Defense (DoD) and U.S DoD contractors only.
- DISTRIBUTION STATEMENT E: Distribution authorized to U.S. Department of Defense (DoD) components only.
- DISTRIBUTION STATEMENT F: Further dissemination only as directed by the controlling DoD office indicated below or by higher authority.
- DISTRIBUTION STATEMENT X: Distribution authorized to U.S. Government agencies and private individuals or enterprises eligible to obtain export-controlled technical data in accordance with DoD Directive 5230.25, Withholding of Unclassified Technical Data from Public Disclosure, 6 Nov 84.

2d. Reason For the Above Distribution Statement (in accordance with DoD Directive 5230.24)

2e. Controlling Office

HQ AFCEE

2f. Date of Distribution Statement Determination

15 Nov 2000

3. This report is NOT forwarded for the following reasons. (Please check appropriate box)

- It was previously forwarded to DTIC on (date) and the AD number is
- It will be published at a later date. Enter approximate date if known.
- In accordance with the provisions of DoD Directive 3200.12, the requested document is not supplied because:

Print or Type Name

Laura Peña

Telephone

210-536-1431

Signature

Laura Peña

(For DTIC Use Only)

AQ Number M01-02-0400

CONTENTS

	<u>Page</u>
SECTION 1 - INTRODUCTION	1-1
SECTION 2 - SYSTEM DESCRIPTION	2-1
2.1 Blower System	2-1
2.2 Monitoring and Flow Control Equipment	2-1
2.2.1 Monitoring Gauges	2-1
2.2.2 Flow Control Equipment	2-1
SECTION 3 - SYSTEM MAINTENANCE	3-1
3.1 Blower/Motor	3-1
3.2 Air Filter	3-1
3.3 Maintenance Schedule	3-1
3.4 Major Repairs	3-2
SECTION 4 - SYSTEM MONITORING	4-1
4.1 Blower Performance Monitoring	4-1
4.1.1 Vacuum/Pressure	4-1
4.1.2 Temperature	4-1
4.2 Monitoring Schedule	4-1
4.3 Reporting Monitoring Results	4-1
APPENDIX A Regenerative Blower Information	
APPENDIX B Data Collection Sheets	

SECTION 1

INTRODUCTION

This Operations and Maintenance (O&M) Manual has been created as a guide for monitoring and maintaining the performance of the full-scale bioventing blower system and vent well plumbing at former Wurtsmith Air Force Base (AFB), Michigan. Record drawings of the full-scale bioventing system installed at Sites SS-06 and ST-40 have been provided to Wurtsmith Air Force Base Conversion Agency (AFBCA) personnel.

Bioventing is the forced injection of fresh air, or withdrawal of soil gas, to enhance the supply of oxygen in subsurface soils for *in situ* bioremediation. A blower system is used to inject air into the soil, thereby supplying fresh atmospheric air (with approximately 20.8 percent oxygen) to contaminated soils. Once oxygen is provided to the subsurface, existing bacteria aerobically break down fuel residuals. Aerobic biodegradation is much more efficient than anaerobic biodegradation which occurs in oxygen depleted soils.

Parsons Engineering Science, Inc. (Parsons ES) has installed an air injection bioventing system consisting of one air injection blower, eight vent wells (VWs), nine soil gas monitoring points (MPs), and associated piping at the site. Following the installation and testing of a pilot-scale bioventing system from 22 July to 31 July 1996, Parsons ES installed a full-scale bioventing system and initiated system operation on 4 August 1996. The air injection rates of the full-scale bioventing system were optimized at each vent well in October 1996 to assure adequate aeration of contaminated soils to promote aerobic biodegradation.

AFBCA personnel assigned to Wurtsmith AFB are responsible for routine monitoring of the bioventing system. Parsons ES has trained AFBCA personnel on the maintenance requirements of this plan. If significant problems are encountered with the operation of the system, Parsons ES should be notified so repairs can be made. Under the Extended Bioventing Project Option 1, Parsons ES is responsible for system repair for a 1-year period after system startup. Parsons ES will retain responsibility for system repair until August 1997. Should the bioventing system cease to operate or develop a significant problem, please call the Parsons ES Site Manager, Mr. John Hall, at (970) 244-8829, or Mr. Craig Snyder, at (303) 831-8100. If the system ceases to operate, please have a base electrician verify that adequate power is being supplied to the bioventing system blower motor prior to notifying Parsons ES.

SECTION 2

SYSTEM DESCRIPTION

2.1 BLOWER SYSTEM

A Gast[®] R6 blower powered by a 3-horsepower direct drive motor was installed at Sites SS-06 and ST-40 in August 1996. The R6 blower is rated as having a maximum flow rate of 215 standard cubic feet per minute (scfm) at open flow and a maximum pressure of 60 inches of water. As installed, the blower at Sites SS-06 and ST-40 was producing an estimated flow rate of 146 actual cubic feet per minute (acfm) at a pressure of 29 inches of water. Following adjustment of VW air injection rates in October 1996, approximately 27 acfm is being injected into VW1, 27 acfm into VW2, 20 acfm into VW3, 20 acfm into VW4, 21 acfm into VW5, 17 acfm into VW6, 6 acfm into VW7, and 11 acfm is being injected into VW8. The remainder of the flow is being bled to the atmosphere. Flow was optimized to each VW based on the degree of hydrocarbon contamination present within soils in the vicinity of each VW and the amount of oxygen at system MPs following two months of operation. The blower system includes an inlet air filter to remove any particulates which are entrained in the inlet air stream and several valves and monitoring gauges which are described in Section 2.2. A schematic of the full-scale blower system installed at Sites SS-06 and ST-40 is shown in the record drawings supplied to the base. Corresponding blower performance curves and relevant service information are provided in Appendix A. Blower system data collection sheets for use by facility personnel are provided in Appendix B.

2.2 MONITORING AND FLOW CONTROL EQUIPMENT

2.2.1 Monitoring Gauges

The bioventing system is equipped with vacuum, pressure, and temperature gauges, and air velocity measurement ports. Gauges have been installed on the air injection system at the following locations: a vacuum gauge in the inlet piping and pressure and temperature gauges in the outlet piping.

2.2.2 Flow Control Equipment

Manual and automatic flow control valves (FCVs) have been installed on the bioventing blower system. Manual FCVs have been installed in the piping leading to each VW to enable the flow rate to each VW to be adjusted individually. An automatic FCV, or pressure relief valve (PRV), is used to protect the blower system from burning out if pressures rise due to pipe blockage. The PRV is set to bleed off flow at a preset pressure and thus prevent blower outlet pressure from ever exceeding the rated pressure.

An additional FCV (bleed valve) has been installed to control the total air flow out of the blower by releasing excess air flow to the atmosphere. The FCVs have been set by Parsons ES personnel to deliver a calculated amount of air to each VW and should not be adjusted unless directed to do so by Parsons ES personnel.

The blower system has also been equipped with flow measurement ports. These ports consist of brass bushings installed in the outlet piping leading to each VW. These bushings, which should be plugged during system operation, allow the insertion of a thermal anemometer for the measurement of air velocity. These ports are used by Parsons ES for system optimization.

Although the blower system installed at Sites SS-06 and ST-40 is relatively maintenance free, periodic system maintenance is required for proper operation and long life. Recommended maintenance procedures and schedule are described in detail in the instruction manuals included in Appendix A and briefly summarized in this section.

Filter inspection must be performed with the system turned off. Do not change the flow control valve settings (valves have been pre-set for a specific flow rate) before re-starting the blower.

SECTION 3

SYSTEM MAINTENANCE

3.1 BLOWER/MOTOR

The blower and motor are relatively maintenance free and should not require any maintenance during the operational period. Both the blower and motor have sealed bearings and do not require lubrication.

3.2 AIR FILTER

To avoid damage caused by passing solids through the blower, an air filter has been installed in-line before the blower. The paper filter element is accompanied by a polyurethane foam pre-filter. The filter should be checked weekly for the first 2 months of operation. A facility employee should determine the best schedule for filter replacement based on the first 2 months of system monitoring. The polyurethane pre-filters can be washed with lukewarm water and a mild detergent. Paper filter elements should never be washed, and should be disposed of and replaced as necessary. When the vacuum drop across the filter increases by approximately 10 inches of water from the vacuum when the filter was new, a dirty filter element should be suspected, and cleaning or replacement should be performed. The initial vacuum when the filter element was new was 13 inches of water. Therefore, the filter should be cleaned or replaced when the vacuum increases to 23 inches of water. Typical filter element replacement intervals range from 3 to 6 months.

To remove the filter, turn the system off by pushing the stop button on the starter, loosen the three clamps or the wing nut on the filter top, lift the metal top off the air filter, and lift the air filter element from the metal housing. Remove the polyurethane pre-filter (if applicable) and wash before replacing.

The filter element is manufactured by Solberg Manufacturing, Inc. in Itasca, Illinois. Their toll free telephone number is 1-800-451-0642. Additional filters can also be obtained through Parsons ES. The Parsons ES contacts are Mr. John Hall, at (970) 244-8829, and Mr. Craig Snyder, at (303) 831-8100. The part number for the replacement filter element is 30P. Four spare air filter elements have been placed inside the blower enclosure.

3.3 MAINTENANCE SCHEDULE

The following maintenance schedule is recommended for the blower system. During the initial few months of operation more frequent monitoring is recommended to ensure that any startup problems are quickly corrected. A daily drive-by inspection is recommended during

the initial 2 weeks of operation to ensure that the blower system is still operating with no unusual sounds. Thereafter monitoring inspections every 2 weeks are recommended (see Section 4). Preprinted data collection sheets have been provided to the facility. Extra data collection sheets for recording maintenance activities are provided in Appendix B.

<u>Maintenance Item</u>	<u>Maintenance Frequency</u>
Filter	Check once every 2 weeks, wash or replace as necessary (see Section 3.3). Inlet vacuum exceeding 23 inches of water indicates that the filter requires cleaning or replacement.

3.4 MAJOR REPAIRS

Blowers systems are very reliable when properly maintained. Occasionally, however, a motor or blower will develop a serious problem. If a blower system fails to start, and a qualified electrician verifies that power is available at the blower or starter, Parsons ES should be contacted to arrange for repairs. The Parsons ES contacts are Mr. John Hall, at (970) 244-8829, and Mr. Craig Snyder, at (303) 831-8100. Parsons ES is responsible for major repairs during the first year of operation.

SECTION 4

SYSTEM MONITORING

4.1 BLOWER PERFORMANCE MONITORING

To monitor the blower performance, the vacuum, pressure, and temperature will be measured. These data should be recorded every 2 weeks on a data collection sheet (provided in Appendix B). All measurements should be taken at the same time while the system is running. Because the systems are noisy, hearing protection should be worn at all times.

4.1.1 Vacuum/Pressure

With hearing protection in place, unlock and open the blower enclosure and record all vacuum and pressure readings directly from the gauges (in inches of water). Record the measurements on the data collection sheet.

4.1.2 Temperature

With hearing protection in place, open the blower enclosure and record the temperature readings directly from the gauges in degrees Fahrenheit (°F). Record the measurements on a data collection sheet (provided in Appendix B). The temperature change can be converted to degrees Celsius (°C) using the formula $^{\circ}\text{C} = (^{\circ}\text{F} - 32) \times 5/9$.

4.2 MONITORING SCHEDULE

The following monitoring schedule is recommended for these systems. During the initial month of operation, more frequent monitoring is recommended to ensure that any start up problems are quickly corrected. Data collection sheets have been provided to assist your data collection and are included in Appendix B.

<u>Monitoring Item</u>	<u>Monitoring Frequency</u>
Vacuum/Pressure	Once every 2 weeks.
Temperature	Once every 2 weeks.

4.3 REPORTING MONITORING RESULTS

System monitoring data sheets should be faxed to the Parsons ES Site Manager, Mr. John Hall at (970) 244-8829, once every 2 months. However, if a significant change in the system

temperature or pressure is noted (such as a significant drop or increase in pressure) please call Mr. Hall at (970) 244-8829 immediately. A significant change in system temperature or pressure may be indicative of a problem with the air delivery system or blower.

APPENDIX A

REGENERATIVE BLOWER INFORMATION

Gast Manufacturing Corp.
P.O. Box 97
Benton Harbor, MI 49023-0097
(616) 926-6171

Model R6130Q-50

Motor Specifications

<u>Phase</u>	<u>HZ</u>	<u>HP</u>	<u>Voltage</u>	<u>Full Load Amps</u>
1	50	3	230	16.3

Overall Dimensions

<u>Height</u>	<u>Width</u>	<u>Depth</u>	<u>Net Weight</u>
15.38 in 391 mm	20.13 in 511 mm	15.30 in 3898 mm	129 lb 59 kg

Performance

<u>Maximum Vacuum</u>	<u>Maximum Pressure</u>	<u>Maximum Flow</u>
70 inH2O 174 mbar	60 inH2O 149 mbar	215 cfm 365 m ³ h

SOIL VAPOR EXTRACTION PUMPS - REGENERATIVE BLOWERS

Model R3

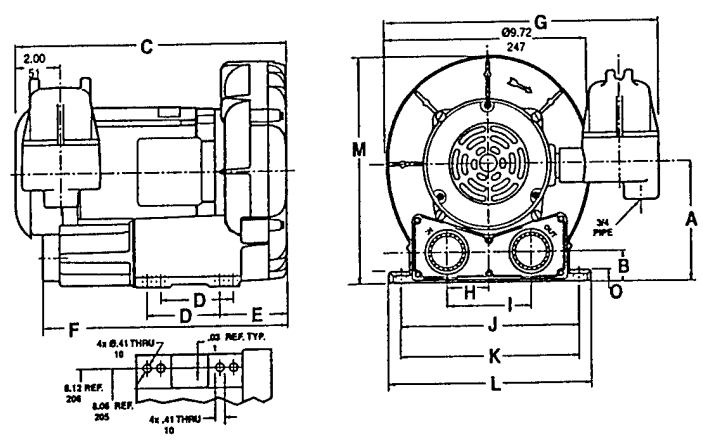

Models R6P, R7

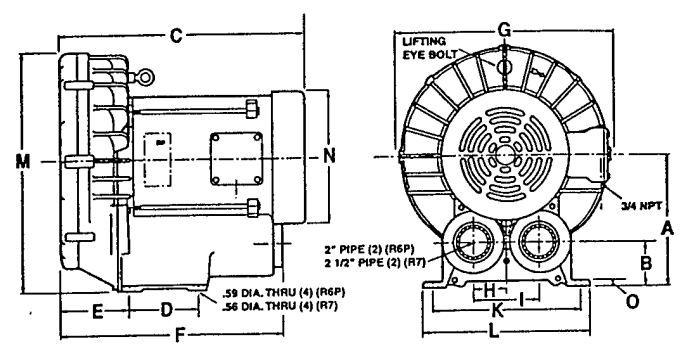

Models R4, R4P, R5, R6

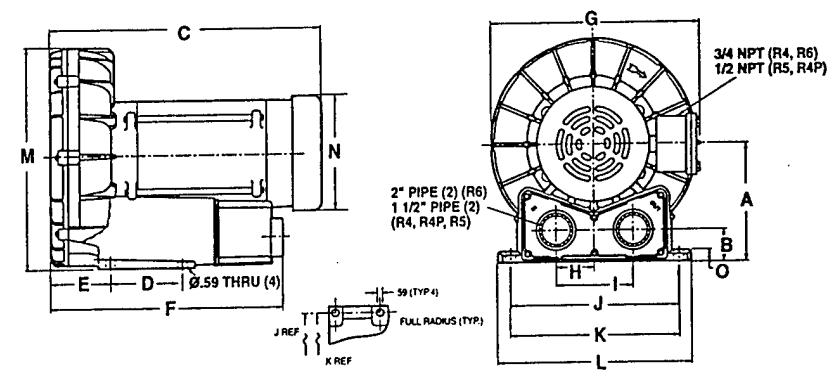

Model	Product Dimensions														
	Metric (mm)							U.S. Imperial (inches)							
	A	B	C	D	E	F	G	H	I	J	K	L	M	N	O
R3105N-50	131	35	310	83	80	281	324	49	99	205	206	238	258	-	13
	5.17	1.37	12.20	3.25	3.03	11.06	12.75	1.94	3.88	8.06	8.12	9.38	10.15	-	.53
R4110N-50	157	43	389	95	72	316	313	50	101	225	227	254	293	175	11
	6.18	1.68	15.30	3.75	2.85	12.44	12.31	1.98	3.96	8.86	8.93	10.00	11.73	6.88	.44
R4310P-50	157	43	356	95	72	316	313	50	101	225	227	254	293	175	11
	6.18	1.68	14.03	3.75	2.84	12.44	12.31	1.98	3.96	8.86	8.93	10.00	11.73	6.88	.44
R4P115N-50	177	47	442	114	83	354	338	60	121	260	262	298	346	175	15
	6.98	1.84	17.41	4.50	3.25	13.93	13.31	2.38	4.75	10.25	10.31	11.75	13.6	6.88	.60
R5125Q-50	178	46	445	114	91	361	344	60	121	260	262	298	350	173	15
	7.00	1.82	17.50	4.50	3.58	14.22	13.56	2.38	4.75	10.25	10.31	11.75	13.78	6.81	.59
R5325R-50	178	46	423	114	91	361	344	60	121	260	262	298	350	183	15
	7.00	1.82	16.66	4.50	3.58	14.22	13.56	2.38	4.75	10.25	10.31	11.75	13.78	7.19	.59
R6130Q-50	197	49	511	140	98	404	389	62	125	289	290	329	391	217	13
	7.75	1.94	20.13	5.50	3.85	15.89	15.30	2.46	4.92	11.38	11.42	12.96	15.38	8.56	.52
R6340R-50	197	49	478	140	98	404	385	62	125	289	290	329	390	217	13
	7.75	1.94	18.82	5.50	3.85	15.89	15.17	2.46	4.92	11.38	11.42	12.96	15.34	8.56	.52
R6P155Q-50	248	80	602	140	137	438	428	64	127	-	290	325	463	257	13
	9.77	3.15	23.7	5.51	5.39	17.25	16.87	2.50	5.00	-	11.42	12.80	18.21	10.12	.50
R6P355R-50	248	80	554	140	137	438	428	64	127	-	290	325	463	257	13
	9.77	3.15	21.80	5.51	5.39	17.25	16.87	2.50	5.00	-	11.42	12.80	18.21	10.12	.50
R7100R-50	274	92	577	216	212	545	457	100	200	-	375	410	509	257	14
	10.79	3.64	22.72	8.50	8.33	21.46	18.00	3.94	7.88	-	14.76	16.14	20.02	10.12	.56

Notice: Specifications subject to change without notice.

SOIL VAPOR EXTRACTION PUMPS - REGENERATIVE BLOWER

Product Specifications

Model Number	Phase	Hz	Motor Specifications			Max Vac		Max Pressure		Max Flow		Net. Wt.	
			Voltages	HP	Full Load Amps	"H ₂ O mbar	"H ₂ O mbar	cfm	m ³ /h	lbs	kg		
R3105N-50	Single	50	110/220-240	.33	3-8/1.9-2.0	28	70	31	77	43	73	52	24
		60	115/208-230	0.5	5.2/2.9-2.6	40	100	43	107	53	90		
R4110N-50	Single	50	110/220-240	0.6	9.2/5.2-4.6	35	87	38	95	74	126	60	28
		60	115/208-230	1.0	11.4/6.2-5.6	48	120	51	127	92	156		
R4310P-50	Three	50	220/380	0.6	3.2/1.6	35	87	38	95	74	126	58	27
		60	208-230/460	1.0	3.4-3.3/1.65	48	120	51	127	92	156		
R4P115N-50	Single	50	110/220-240	1.0	15.2/7.6-8	40	100	45	112	112	190	79	36
		60	115/208-230	1.5	18.2/9.7-9.1	60	149	65	162	133	226		
R5125Q-50	Single	60	115/230	2.0	25/12.5	60	149	55	137	160	272	77	35
R5325R-50	Three	50	190-220/380-415	1.5	5.0-4.4/2.5-2.6	47	117	50	125	133	226	75	34
		60	208-230/460	2.0	6.0-5.6/2.8	60	149	65	162	160	272		
R6130Q-50	Single	50	220-240	2.5	14.7-13.5	65	162	75	187	182	309	129	59
		60	230	3.0	16.3	70	174	60	149	215	365		
R6340R-50	Three	50	190-220/380-415	3.0	14.4-13.4/7.2-6.8	65	162	75	187	180	306	112	51
		60	208-230/460	4.0	13-12/6	80	199	100	249	215	365		
R6P155Q-50	Single	50	220-240	4.0	20.8-19.1	65	162	80	199	235	399	243	110
		60	230	5.5	29.9	85	212	95	237	280	476		
R6P355R-50	Three	50	190-220/380-415	4.5	14.9-11/7.45-5.8	65	162	80	199	232	394	233	105
		60	208-230/460	6.0	20-18/9	85	212	100	249	280	476		
R7100R-50	Three	50	190-220/380-415	8.0	20.8-18.9/10.4-9.5	72	179	80	199	350	595	297	134
		60	208-230/460	10.0	26.5-24/12	90	224	90	224	420	714		

NOTICE: Performance specifications subject to change without notice.

VACUUM

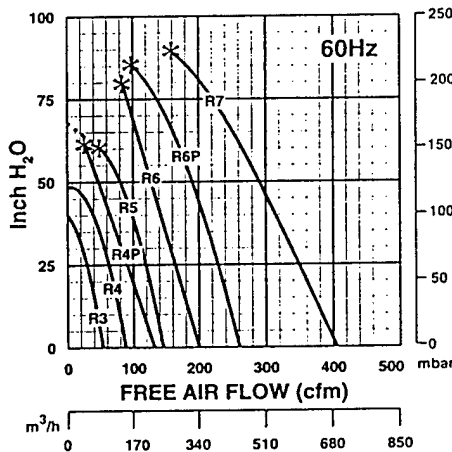
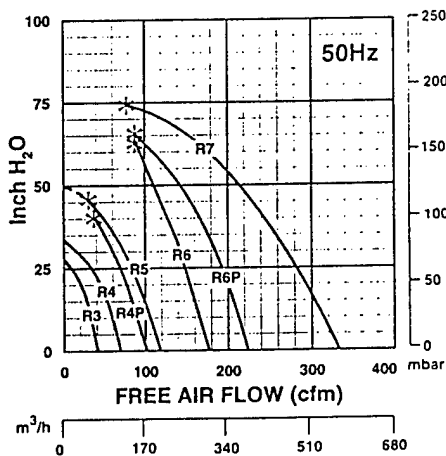

PRESSURE

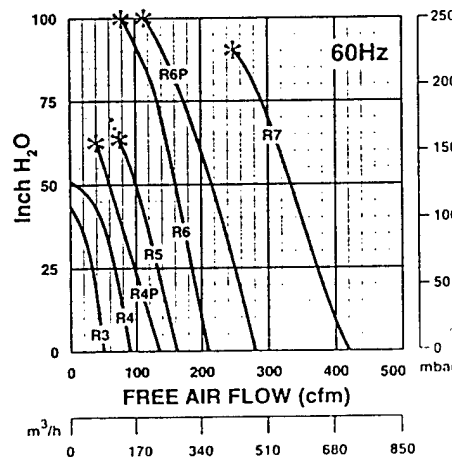
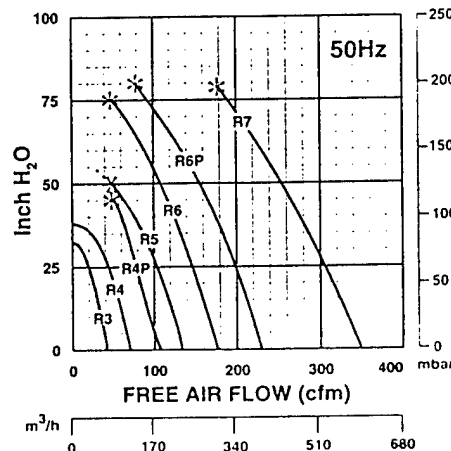

Free software identifies best Gast blowers for soil and groundwater remediation

Now you can size and select regenerative blowers and accessories for soil and groundwater remediation systems faster, easier and more accurately than ever before. Gast remediation system engineering software does the job and it is yours for the asking. The 3-1/2-inch IBM-compatible disk calculates performance when the blower is operating with both a vacuum and pressure load at the same time. The programs will also compensate for changes in performance from altitude and temperature, helping you identify the optimum Gast blowers for your application.

Call 1-800-952-4278 to receive your free remediation system engineering software.



Post Office Box 97
Benton Harbor, Michigan 49023-0097
Ph: 616/926-6171
Fax: 616/925-8288

Maintenance Instructions for Gast Standard Regenerative Blowers

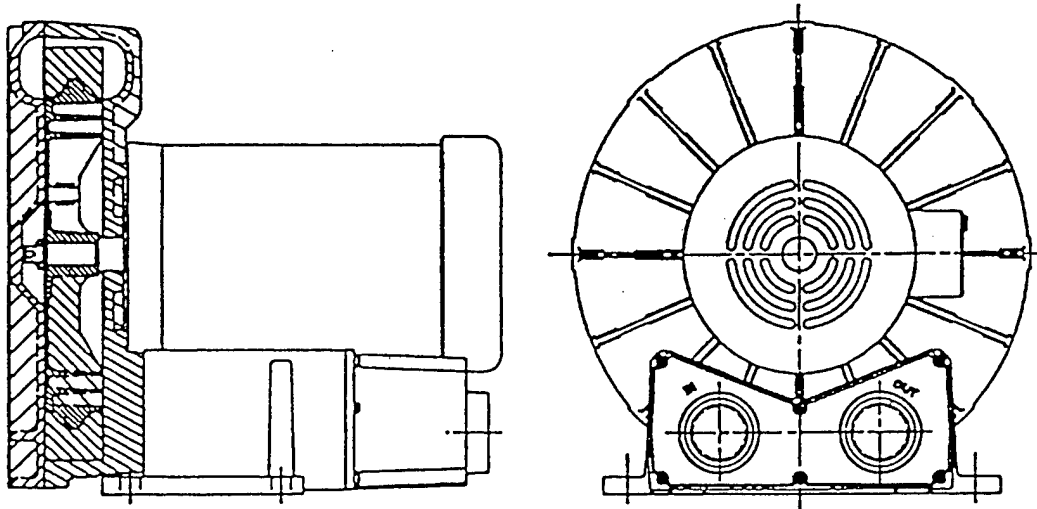

For original equipment manufacturers
special models, consult your local distributor

Gast Rebuilding Centers

Gast Mfg. Corp.
2550 Meadowbrook Rd.
Benton Harbor MI. 49022
Ph: 616/926-6171
Fax: 616/925-8288

Gast Mfg Corp.
505 Washington Avenue
Carlstadt, N. J. 07072
Ph: 201/933-8484
Fax: 201/933-5545

Brenner Fiedler. & Assoc.
13824 Bentley Place
Cerritos, CA. 90701
Ph: 213/404-2721
Fax: 213/404-7975

Walnbee, Limited
121 City View Drive
Toronto, Ont. Canada M9W 5A9
Ph: 416/243-1900
Fax: 416/243-2336

Walnbee, Limited
215 Brunswick Drive
Pointe Claire, P.Q. Canada H9R 4R7
Ph: 514/697-8810
Fax: 514/697-3070

Gast Mfg. Co. Limited.
Hallfax Rd, Cressex Estate
High Wycombe, Bucks HP12 3SN
Ph. 44 494 523571
Fax: 44 494 436588

Japan Machinery Co. Ltd.
Central PO Box 1451
Tokyo 100-91 Japan
Ph: 813/3573-5421
Fax: 813/3571-7865

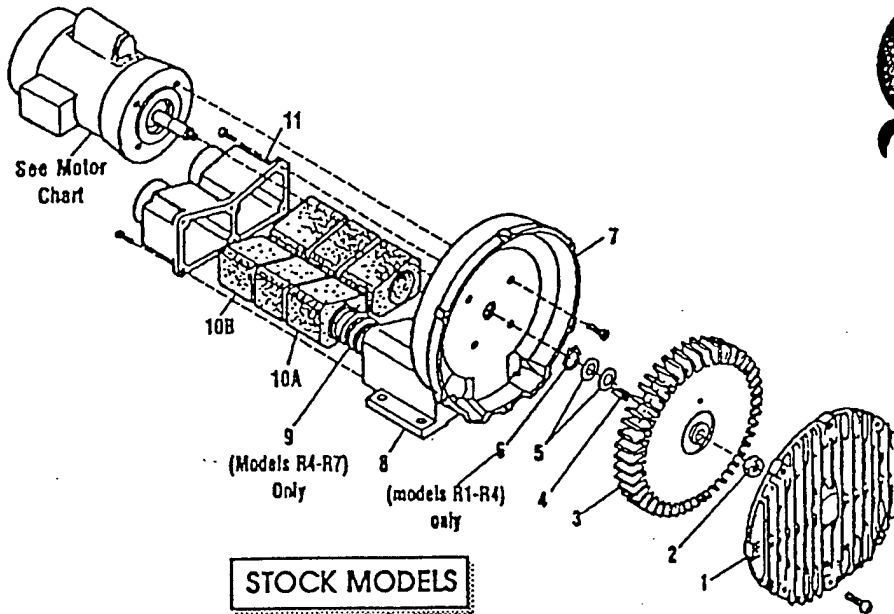

Part Name	R1	R2	R3	R4	R5	R6	R6P	R6PP/R6PS	R7
#1 Cover	AJ101A	AJ101B	AJ101C	AJ101D	AJ101EQ	AJ101F	AJ101K	(2)AJ101KA	AJ101G
#2 Stopnut	BC187	BC187	BC181	BC181	BC181	BC181	BC181	(2)BC182	BC183
#3 Impeller	AJ102A	AJ102BQ	AJ102C	AJ102D	AJ102E	AJ102FR	AJ102K	(2)AJ102KA	AJ102GA
#4 Square Key	AH212C	AH212	AB136A	AB136D	AB136	AB136	AB136	(2)AB136	AC628
#5 Shim Spacer (s)	AJ132	AE686-3	AJ109	AJ109	AJ109	AJ116A	AJ116A	AJ116A	AJ110
#6 Retaining Ring	AJ145	AJ145	AJ149	AJ149					
#7 Housing	AJ103A	AJ103BQ	AJ103C	AJ103DR	AJ103E	AJ103F	AJ103K	AJ103KD	AJ103GA
#8 Muffler Box					AJ104E	AJ104F			
#9 Spring				AJ113DR	AJ113DQ	AJ113FQ	AJ113FQ		AJ113G
#10A Foam	(4)AJ112A	(4)AJ112B	(4)AJ112C	(4)AJ112DS	(4)AJ112ER	(6)AJ112F	(8)AJ112K		(8)AJ112GA
#10B Foam		(2)AJ112BQ	(2)AJ112CQ	(2)AJ112DR	(2)AJ112EQ				
#11 Muffler Extension/ Adapter Plate	AJ106H	AJ106BQ	AJ106CQ	AJ106DQ	AJ106EQ	AJ106EQ	AJ104K		AJ104GA
Shim Kit	K396	K396							K395

MOTOR CHART

REGENAIR MODEL NUMBER	MOTOR NUMBER	MOTOR SPECIFICATIONS		PHASE
		60 HZ VOLTS	50 HZ VOLTS	
R1102	J111X	115/208-230	110/220-240	1
R1102C	J112X	115		1
R2103	J311X	115/208-230	110/220	1
R2105	J411X	115/208-230	110/220	1
R2303A	J310	208-230/460	220/380-415	3
R2303F	J313	208-230	220	3
R3105-1/R3105-12	J411X	115/208-230	110/220-240	1
R3305A-1/R3305A-13	J410	208-230/460	220/380-415	3
R4110-2	J611AX	115/208-230	110/220-240	1
R4310A-2	J610	208-230/460	220/380-415	3
R5125-2	J811X	115/208-230		1
R5325A-2	J810X	208-230/460	220/380-415	3
R6125-2	J811X	115/208-230		1
R6325A-2	J810X	208-230/460	220/380-415	3
R6335A-2	J910X	208-230/460	220/380-415	3
R6150J-2	J1013	230		1
R6350A-2	J1010	208-230/460	220/380-415	3
R6P335A	J910X	208-230/460	220/380-415	3
R6P350A	J1010	208-230/460	220/380-415	3
R6P355A	J1110A	208-230/460	220/380-415	3
R7100A-2*	J1210B	208-230/460	220/380-415	3
R6PP/R6PS3110M	JD1100	208-230/460	220/380-415	3

* No lubrication needed at start up. Bearings lubricated at factory.

* Motor is equipped with alemite fitting. Clean tip of fitting and apply grease gun. Use 1 to 2 strokes of high quality ball bearing grease.

Consistency	Type	Typical Grease
Medium	Lithium	Shell Dolum R

Hours of service per year	Suggested Retube Interval
5,000	3 years

Continual Normal Application 1 year

Seasonal service motor idle for 6 months or more	1 year beginning of season 6 months
--	-------------------------------------

Continuous-high ambient, dirty or moist applications.

All performance figures relate to stock models. A few high pressure units may be available. Consult your local distributor.

Regenalr Model Number	P R E S S U R E						Maximum Pressure "H ₂ O"
	0"H ₂ O	20"H ₂ O	40"H ₂ O	60"H ₂ O	80"H ₂ O	100"H ₂ O	
R1	26	14					28
R2	42	26					38
R3105-1	52	38	14				42
R3105-12	52	36	23				55
R3305A-13	52	36	23				55
R4	90	70	50				52
R5	145	130	100				65
R6125-2	200	180					35
R6325A-2	200	180	152				40
R6335A-2	205	175	155	135			70
R6350A-2	200	180	150	130	110	80	105
R6P335A	290	250					30
R6P350A	300	260	230	200			60
R6P355A	300	260	230	200	160		90
R7100A-2	420	380	340	310	280	230	115
R6PP311OM	485	452	420	380	330		95
R6PS311OM	265	258	252	244	236	226	170

Regenalr Model Number	V A C U U M					Maximum Vacuum "H ₂ O"
	0"H ₂ O	20"H ₂ O	40"H ₂ O	60"H ₂ O	80"H ₂ O	
R1	25	14				26
R2	40	22				34
R3105-1	50	34	9			40
R3105-12	51	34	20			50
R3305A-13	51	34	20			50
R4	82	62	39			48
R5	140	115	90	50		60
R6125-2	190	155	125			45
R6325A-2	190	155	125			45
R6335A-2	190	150	125	100		75
R6350A-2	190	180	150	100	70	90
R6P335A	270	230				37
R6P350A	280	240	210	170		70
R6P355A	280	240	210	170	100	86
R7100A-2	410	350	300	250	170	90
R6PP311OM	470	425	375	320	220	80
R6PS311OM	240	225	210	195	175	130

*This number indicates the maximum static pressure differential recommended (with cooling air still flowing through unit). In general, units 1hp or less can be dead headed. Check with local representative or distributor to verify which models apply.

Operation of the blower above the recommended maximum duty will cause premature failure due to the build up of heat damaging the components.

Performance data was determined under the following conditions:

- 1) Unit in a temperature stable condition.
- 2) Test conditions: Inlet air density at 0.075lbs. per cubic foot. (20°C(68°F), 29.92 in. Hg(14.7PSIA)).
- 3) Normal performance variations on the resistance curve within +/- 10% of supplied data can be expected.
- 4) Specifications subject to change without notice.
- 5) All performance at 60Hz operation.



70-6100
F2-205/8/92
Rev. E

Post Office Box 97
Benton Harbor, MI. 49023-0097
Ph: 616/926-6171
Fax: 616/925-8288

INSTALLATION AND OPERATING INSTRUCTIONS FOR GAST HAZARDOUS DUTY REGENAIR BLOWERS

This instruction applies to the following models ONLY: R3105N-50, R4110N-50, R4310P-50, R4P115N-50, R5125Q-50, R5325R-50, R6130Q-50, R6P155Q-50, R6350R-50, R6P355R-50 and R7100R-50.

Gast Authorized Service Facilities are Located in the locations listed below

Gast Manufacturing Corporation
505 Washington Avenue
Carlstadt, N. J. 07072
Ph: 201/933-8484
Fax: 201/933-5545

Gast Manufacturing Corporation
2550 Meadowbrook Road
Benton Harbor, MI. 49022
Ph: 616/926-6171
Fax: 616/925-8288

Brenner Fiedler & Associates
13824 Bentley Place
Cerritos, CA. 90701
Ph: 310/404-2721
Ph: 800/843-5558
Fax: 310/404-7975

Wainbee Limited
215 Brunswick Blvd.
Pointe Claire, Quebec
Canada H9R 4R7
Ph: 514/697-8810
Fax: 514/-697-3070

Wainbee Limited
5789 Coopers Ave.
Mississauga, Ontario
Canada L4Z 3S6
Ph: 416/243-1900
Fax: 416/243-2336

Japan Machinery
Central PO Box 1451
Toyko 100-91, Japan
Ph: 813 3573-5421
Fax: 813 3571-7896

Gast Manufacturing Co. Ltd.
Halifax Road, Cressex Estate
High Wycombe, Bucks HP12 3SN
England
Ph: 44 494 523571
Fax: 44 494 436588.

OPERATING AND MAINTENANCE INSTRUCTIONS

SAFETY

This is the safety alert symbol. When you see this symbol personal injury is possible. The degree of injury is shown by the following signal words:

⚠ DANGER Severe injury or death will occur if hazard is ignored.

⚠ WARNING Severe injury or death can occur if hazard is ignored.

⚠ CAUTION Minor injury or property damage can occur if hazard is ignored.

Review the following information carefully before operating.

GENERAL INFORMATION

This instruction applies to the following models ONLY: R3105N-50, R4110N-50, R4310P-50, R4P115N-50, R5125Q-50, R5325R-50, R6130Q-50, R6P155Q-50, R6350R-50, R6P355R-50 and R7100R-50. These blowers are intended for use in Soil Vapor Extraction Systems. The blowers are sealed at the factory for very low leakage. They are powered with a U.L. listed electric motor Class 1 Div. 1 Group D motors for Hazardous Duty locations. Ambient temperature for normal full load operation should not exceed 40° C (105° F). For higher ambient operation, contact the factory.

Gast Manufacturing Corporation may offer general application guidance: however, suitability of the particular blower and/or accessories is ultimately the responsibility of the user, not the manufacturer of the blower.

INSTALLATION

DANGER Models R5325R-50, R6130Q-50, R6350R-50, R5125Q-50, R6P155Q-50, R6P355R-50 AND R7100R-50 use Pilot Duty Thermal Overload Protection. Connecting this protection to the proper control circuitry is mandated by UL674 and NEC501. Failure to do so could result in a EXPLOSION. See pages 3 and 4 for recommended wiring schematic for these models.

⚠ WARNING Electric shock can result from bad wiring. A qualified person must install all wiring, conforming to all required safety codes. Grounding is necessary.

⚠ WARNING This blower is intended for use on soil vapor extraction equipment. Any other use must be approved in writing by Gast Manufacturing Corp. Install this blower in any mounting position. Do not block the flow of cooling air over the blower and motor.

PLUMBING - Use the threaded pipe for connection only. They will not support the plumbing. Be sure to use the same or larger size pipe to prevent air flow restriction and overheating of the blower. When installing fittings, be sure to use pipe thread sealant. This protects the threads in the blower housing and prevents leakage. Dirt and chips are often found in new plumbing. Do not allow them to enter the blower.

NOISE - Mount the unit on a solid surface that will not increase the sound. This will reduce noise and vibration. We suggest the use of shock mounts or vibration isolation material for mounting.

ROTATION - The Gast Regenair Blower should only rotate clockwise as viewed from the electric motor side. The casting has an arrow showing the correct direction. Confirm the proper rotation by checking air flow at the IN and OUT ports. If needed reverse rotation of three phase motors by changing the position of any two of the power line wires.

OPERATION

⚠ WARNING Solid or liquid material exiting the blower or piping can cause eye damage or skin cuts. Keep away from air stream.

⚠ WARNING - Gast Manufacturing Corporation will not knowingly specify, design or build any blower for installation in a hazardous, combustible or explosive location without a motor conforming to the proper NEMA or U. L. standards. Blowers with standard TEFC motors should never be utilized for soil vapor extraction applications or where local state and/or Federal codes specify the use of explosion-proof motors (as defined by the National Electric Code, Articles 100,500 c1990).

⚠ CAUTION Attach blower to solid surface before starting to prevent injury or damage from unit movement. Air containing solid particles or liquid must pass through a filter before entering the blower. Blowers must have filters, other accessories and all piping attached before starting. Any foreign material passing through the blower may cause internal damage to the blower.

⚠ CAUTION Outlet piping can burn skin. Guard or limit access. Mark "CAUTION Hot Surface. Can Cause Burns". Air temperature increases when passing through the blower. When run at duties above 50 in. H₂O, metal pipe may be required for hot exhaust air. The blower must not be operated above the limits for continuous duty. Only models R3105N-50, R4110N-50 and R4310P-50 can be operated continuously with no air flowing through the blower. Other units can only be run at the rating shown on the model number label. Do not Close off inlet (for vacuum) to reduce extra air flow. This will cause added heat and motor load. Blower exhaust air in excess of 230°F indicates operation in excess of rating which can cause the blower to fail.

ACCESSORIES ...Gast pressure gauge AJ496 and vacuum gauges AJ497 or AE134 show blower duty. The Gas pressure/vacuum relief valve, AG258, will limit the operating duty by admitting or relieving air. It also allows full flow through the blower when the relief valve closes.

SERVICING

⚠ WARNING To retain their sealed construction they should be serviced by Gast authorized service centers ONLY. These models are sealed at the factory for very low leakage.

⚠ WARNING Turn off electric power before removing blower from service. Be sure rotating parts have stopped. Electric shock or severe cuts can result. Inlet and exhaust filters attached to the blower may need cleaning or replacement of the elements. Failure to do so will result in more pressure drop, reduced air flow and hotter opera-

tion of the blower. The outside of the unit requires cleaning of dust and dirt. The inside of the blower also may need cleaning to remove foreign material coating the impeller and housing. This should be done at a Gast Authorized Service Center. This buildup can cause vibration, failure of the motor to operate or reduced flow.

KEEP THIS INFORMATION WITH THIS BLOWER. REFER TO IT FOR SAFE INSTALLATION, OPERATION OR SERVICE.

MOTOR WIRING DIAGRAM FOR R4110N-50 & R3105N-50

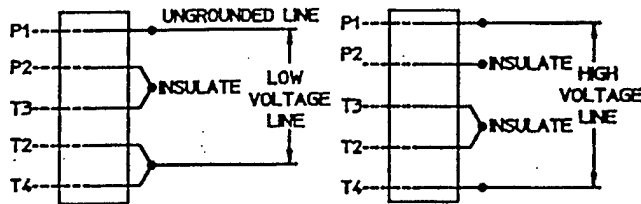

>> * WARNING
THIS MOTOR IS THERMALLY PROTECTED AND WILL AUTOMATICALLY RESTART WHEN PROTECTOR RESETS. ALWAYS DISCONNECT POWER SUPPLY BEFORE SERVICING.

MOTORS WIRING DIAGRAM FOR R4310P-50

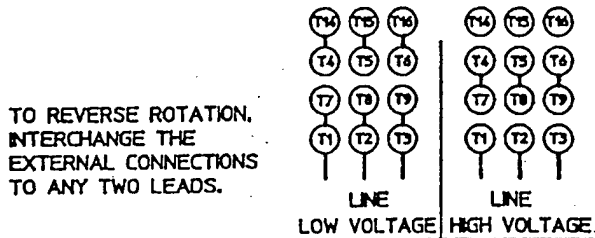

>> * WARNING
THIS MOTOR IS THERMALLY PROTECTED AND WILL AUTOMATICALLY RESTART WHEN PROTECTOR RESETS. ALWAYS DISCONNECT POWER SUPPLY BEFORE SERVICING.

MOTORS WIRING DIAGRAM FOR R5325R-50, R6350R-50, R6P355R-50, & R7100R-50

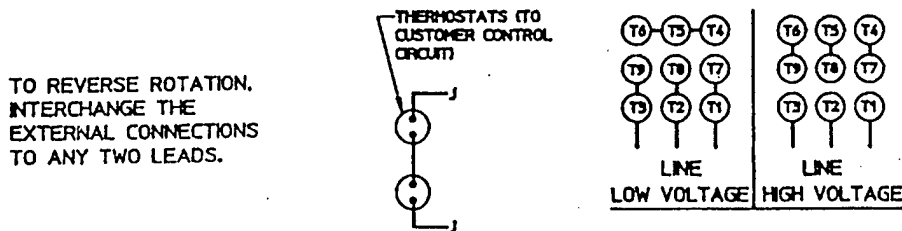

MOTOR WIRING DIAGRAM FOR R5125Q-50 & R4P115N-50

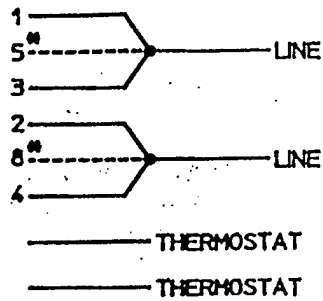

LOW VOLTAGE

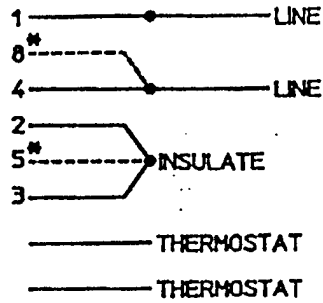

HIGH VOLTAGE

* R5125Q-50 BLOWERS PRODUCED AFTER SEPTEMBER 1992 (SER. NO. 0992) DO NOT HAVE MOTOR LEADS 5 & 8.

MOTOR WIRING DIAGRAM FOR R6130Q-50 & R6P155Q-50

CONNECT THERMOSTAT TO MOTOR PROTECTION CIRCUIT

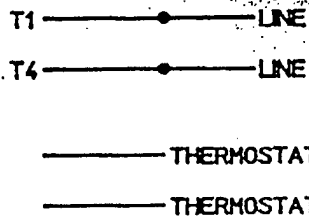

CONNECTION FOR THERMOSTAT MOTOR PROTECTION

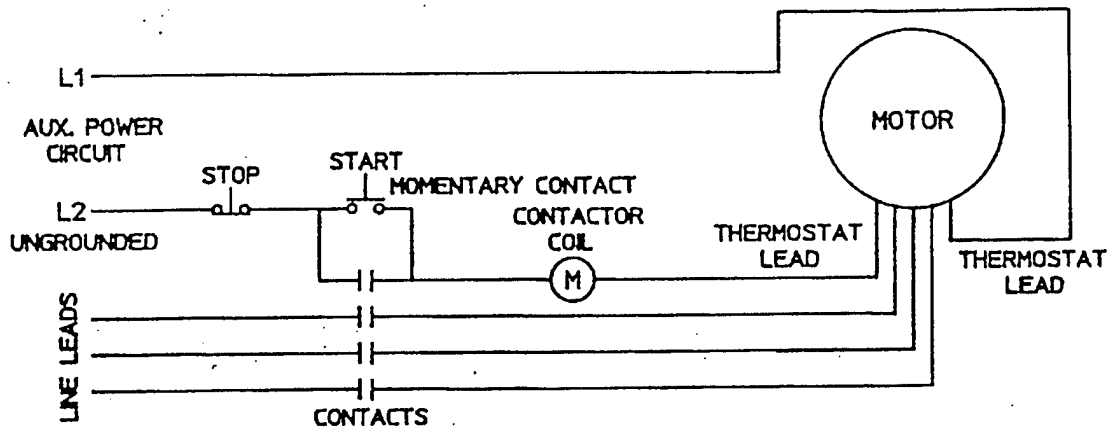

TERMOSTATS TO BE CONNECTED IN SERIES WITH CONTROL AS SHOWN. MOTOR FURNISHED WITH AUTOMATIC THERMOSTATS RATED A.C. 115-600V. 720VA

Blower Accessories

In-line Filters

The impeller of a blower passes very close to the housing. It is always wise to have an inlet or in-line filter to ensure troublefree life.



Model No.	R4	R5	R6,R6P	R7
Part No.	AJ151D	AJ151E	AJ151G	AJ151H
Replacement Element	AJ135E	AJ135F	AJ135G	AJ135C
Micron	10	10	10	10

Vacuum and Pressure Gauges

To monitor the system performance so as not to exceed maximum duties. Using two (one on each side of the filter) is a great way to know when the filter needs servicing.

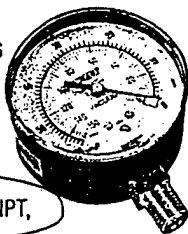

- Vacuum Gauge, Part #AJ497, 2 5/8" Dia., 1/4" NPT, 0-60 in. H₂O and 0-150 mbar
- Vacuum Gauge, Part #AE134, 2 5/8" Dia., 1/4" NPT, 0-160 in. H₂O and 0-400 mbar
- Pressure Gauge, Part #AJ496, 2 5/8" Dia., 1/4" NPT, 0-60 in. H₂O and 0-150 mbar
- Pressure Gauge, Part #AE133, 2 5/8" Dia., 1/4" NPT, 0-160 in. H₂O and 0-400 mbar
- Pressure Gauge, Part #AE133A, 2 5/8" Dia., 1/4" NPT, 0-200 in. H₂O

Horizontal Swing Type Check Valve

Designed to prevent back-wash of fluids that would enter the blower. Also prevents air back-streaming if needed. They can be mounted with their discharge either vertical or horizontal. Valve will open with 3" of water pressure.

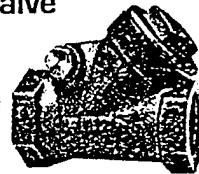

Model No.	R4,R5	R6,R6P	R7
Part No.	AH326D	AH326F	AH326G
	1 1/2" NPT	2" NPT	2 1/2" NPT

Moisture Separator

The purpose of the moisture separator is to remove liquids from the gas stream in a soil vapor extraction process. This helps protect the blower from corrosion and a build up of mineral deposits.



MODEL	LIQUID CAPACITY GALLONS	USED ON
RMS160	10	R4, R4P, R5
RMS200	19	R4, R4P, R5, R6
RMS300	19	R5, R6, R6P
RMS400	40	R6P, R7

Relief Valve

By setting a relief valve at a given pressure/vacuum you can be assured that no harm will come to the blower or products in your application from excessive duties.

- Pressure/Vacuum Relief Valve, 1 1/2" NPT, Adjustable 30 - 170 in. H₂O, 200 cfm max. Part #AG258

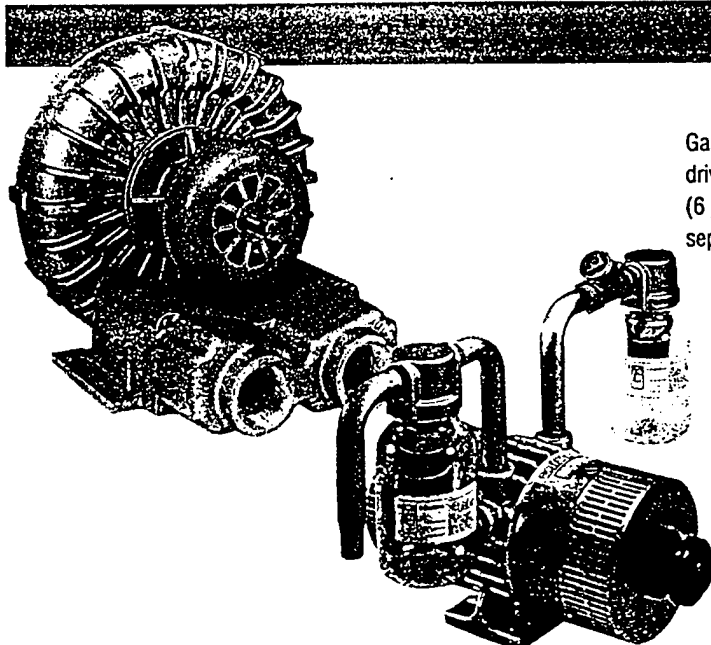
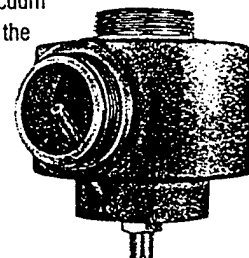

Gast also offers other models that are ideal for soil sparging. Our separate drive blowers are available in 4 sizes to 15 hp, pressures to 170" H₂O (6 psi). Rotary vane compressors are available in motor mounted or separate drive styles up to 5 hp, pressures to 20 psi.



LOW PRESSURE GAUGES

Types 611.10 & 612.20

WIKA INSTRUMENT CORPORATION
 1000 Wiegand Boulevard
 Lawrenceville, Georgia 30243-5868
 (404) 513-8200 1-800-645-0608
 FAX: (404) 513-8203

PRICE LIST

Type 611.10 2 1/2" (63mm)
 Type 612.20 4" (100mm)

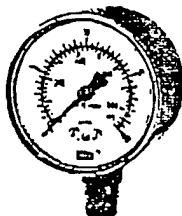

Standard Features

- Case: Black painted steel (611.10)
 Stainless steel (612.20)
- Bayonet Ring: None (2 1/2")
 Stainless steel (4")
- Wetted Parts: Copper alloy
- Window: Acrylic (2 1/2")
 Instrument glass (4")
- Dial: White aluminum
- Pointer: Black aluminum
- Accuracy: ± 1.5% of span

Brass movement with highly polished bearing surfaces

Recalibration screw on dial

Special Order Options

50 pcs. minimum order quantity per line item required (611.10)
 25 pcs. minimum order quantity per line item required (612.20)

Custom Dials - Special scales and dial markings are available. Standard list prices apply. Add any applicable artwork/set-up charges. Refer to "Custom Dial Artwork Charges" (price page PL95-32).

Special Connections - No additional charge for standard NPT or metric threads. Contact factory for other special threads.

Gauge Accessories - Additional accessories may be available. Refer to "Pressure Gauge Accessories" (price page PL95-30).

Additional Options Available -

- Nickel or chrome plated connection
- Lower back mount (Type 612.20 only)
- Rear flange
- U-clamp
- Safety glass window
- Stainless steel wetted parts 2 1/2" (631.10)
- Stainless steel wetted parts 4" (632.50)
- (refer to price page PL95-21 for prices)
- Cleaned for oxygen service
- Stainless steel case and ring
- Red drag pointer

- * Items with part numbers are available from stock (subject to prior sale).
- * Please use applicable part numbers when ordering.
- * Items shown without part numbers are available on special order at no additional charge. Above listed minimum order quantities per line item required. Contact factory for current lead times.

Type	611.10		612.20	
Size	2 1/2"		4"	
Connection	LM	CBM	LM	
Conn. Size	1/4" NPT			
Data Sheet	APM 06.01		APM 06.02	
List Price	\$43.25	\$47.55	\$139.15	
Vacuum Range (dual scale)				
	inch water	mm water		
	0-30	0-760	9852344	9851852 9747724
	0-60	0-1500	9748321	9748339
	0-100	0-2500	9747473	9747465
Pressure Ranges (dual scale)				
	inch water	mm water		
	0-15	0-380	9851682	9851860 9747732
	0-30	0-760	9851690	9855785 9747740
	0-60	0-1500	9851704	9803432 9747758
	0-100	0-2500	9851810	9851879 9747766
	0-200	0-5000	9851828	9851887 9747775
	oz/ sq. in.	mm water		
	0-10	0-440	9851771	
	0-15	0-660	9851780	
	0-20	0-880	9851798	
	0-30	0-1320	9851747	9851917
	0-35	0-1540	9851801	9857273
	0-60	0-2640	9851755	9803548
	oz/ sq. in.	in. water		
	0-20	0-34	9851720	9857281
	0-32	0-55	9851739	9855793
Pressure Ranges (single scale)				
	psi			
	3		9851925	9851836 9747783
	5		9851933	9851844 9747791
Accessories (installed)				
<small>Accessory prices do not apply to orders of 50 pcs or more per line item (25 pcs. for type 612.20). Contact factory for quote.</small>				
FF, chrome plated brass	\$27.55	\$21.55	N/A	
	1327085	1327087		
FF, black painted steel	\$21.30	\$24.55	N/A	
	1327089	1327091		
FF, stainless steel	--	--	\$23.65	
			1327081	
Restrictor, brass	\$.90			
	1326943			

ABBREVIATIONS
 LM - Lower Mount
 CBM - Center Back Mount
 FF - Front Flange
 N/A - Not Available

In keeping with and for purposes of product improvement, Wika reserves the right to make design changes without prior notice.

Prices subject to change without notice.
 This price list supersedes price list dated 01/01/95.
 Effective 03/01/95 or
 Price Page PL95-20

Prices: FOB Lawrenceville, GA
 Terms: 30 days net
 (subject to credit approval)

Warranty

REGARDLESS OF CAUSE, if a product you buy from this brochure does not work right, Gast will repair or replace it once, at no charge, for up to one year from the date of shipment from the factory. In the course of repair or replacement, Gast may send you written recommendations on how to prevent a problem from happening again. Gast reserves the right to withdraw this warranty if you do not follow these recommendations. Customer is responsible for freight charges both to and from Gast in all cases. This warranty does not apply to electric motors, electrical controls, and gasoline engines, which Gast obtains from other manufacturers. A motor or engine carries only the warranty of the company that makes it.

THIS WARRANTY IS EXCLUSIVE AND IS IN LIEU OF ALL OTHER WARRANTIES, WHETHER WRITTEN, ORAL OR IMPLIED, INCLUDING THE WARRANTY OF MERCHANTABILITY AND OF FITNESS FOR ANY PARTICULAR PURPOSE. GAST'S LIABILITY IS IN ALL CASES LIMITED TO THE REPLACEMENT PRICE OF ITS PRODUCT. GAST SHALL NOT BE LIABLE FOR ANY OTHER DAMAGES, WHETHER CONSEQUENTIAL, INDIRECT, OR INCIDENTAL, ARISING FROM THE SALE OR USE OF ITS PRODUCTS.

Gast's sales personnel may modify this warranty, but only by signing a specific, written description of any modifications.

DISCLAIMER

The information presented in this catalog is based on technical data and test results of nominal units. It is believed to be accurate and is offered as an aid in the selection of Gast products. It is the user's responsibility to determine suitability of the product for his intended use and the user assumes all risk and liability whatsoever in connection therewith.

North American Representatives and Distributors

A substantial stock of vacuum pumps, compressors, air motors, parts and accessories are carried by the offices listed below.

- (A) Distributor-plant-use sales only.
- (B) Manufacturers Representative - O.E.M. and plant-use sales.
- (C) Gast warehouse and sales office - O.E.M. and plant-use sales.
- (D) Gast service center.

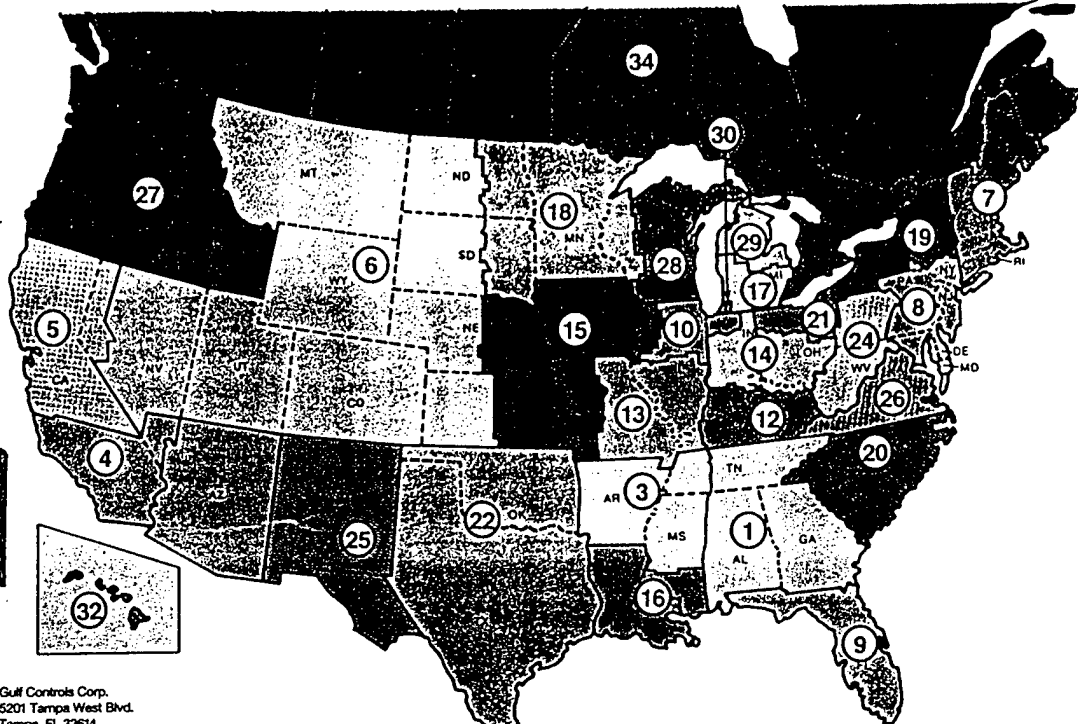

① James E. Watson & Co.
29 Doran Ave.
Marietta, GA 30060
Ph. 404/422-1154
James E. Watson & Co.
Birmingham, AL
Ph. 205/663-6678
James E. Watson & Co.
Nashville, TN
Ph. 615/331-5716

③ Franklin Electrofluid Co., Inc.
(B) 3854 Watman
Memphis, TN 38118
Ph. 901/362-7504
Ph. 1-800-238-7500
Franklin Electrofluid Co., Inc.
8900 Crystal Hill Road
North Little Rock, AR 72113
AR only 1-800-272-5665
Ph. 501/771-4170
Franklin Electrofluid Co., Inc.
5609 South 14th Street
Fl. Smith, AR 72901
Ph. 501/648-7448
Ph. 1-800-264-7406

④ Brenner-Fiedler & Assoc., Inc.
(B,D) 13824 Bentley Place
Cerritos, CA 90701
Ph. 310/404-2721 &
Ph. 714/521-6280
Ph. 1-800-843-5558
Brenner Fiedler & Assoc., Inc.
(B) San Diego, CA
Ph. 619/232-9152
Ph. 1-800-843-5558
Brenner Fiedler & Assoc., Inc.
(B) 2117 South 48th Street #102
Tempe, AZ 85282
Ph. 1-800-638-0394

⑤ TECO Pneumatic, Inc.
(B) 1069 Serpentine Lane
Pleasanton, CA 94566
Ph. 510/426-8500

⑥ Fiero Fluid Power, Inc.
(B) Suite 104
10515 East 40th Ave.
Denver, CO 80239
Ph. 303/373-2600
Fiero Fluid Power, Inc.
(B) 2155 South Main
Salt Lake City, UT 84115
Ph. 801/467-4622

⑦ Onheiser Corp.
(B) 17 Rose Ave.
West Hartford, CT 06103-0332
Connecticut only 203/953-7632
New England States 1-800-858-9368

⑧ GAST
Gast Mfg. Corp.
(C,D) Eastern Sales Office
505 Washington Ave.
Carlstadt, NJ 07072
Ph. 201/933-8484
Ph. 212/563-1870 (NYC)

Dees Corp.
(A) 8860 Kelso Dr.
Baltimore, MD 21221
Ph. 410/574-2900

Die-A-Matic, Inc.
(A) 119 Brown St.
Pittston (Wilkes-Barre), PA 18640
Ph. 717/655-6831

Die-A-Matic, Inc.
(A) 650 N. State St.
York, PA 17403
Ph. 717/846-9300

Van-Air & Hydraulics, Inc.
(A) Philadelphia, PA
Ph. 215/923-2575

Van-Air & Hydraulics, Inc.
(A) 525 E. Woodlawn Ave.
Maple Shade, NJ 08052
Ph. 609/779-7300

⑨ Gulf Controls Corp.
(B) 5201 Tampa West Blvd.
Tampa, FL 33614
Ph. 813/884-0471
Ph. 1-800-282-9125

⑩ GAST
Gast Midwestern Sales Office
(C) 755 N. Edgewood
Wood Dale, IL 60191
Ph. 708/860-7477

⑫ D & F Distributors
(B) 6309 Ulrich Avenue
Louisville, KY 40219
Ph. 502/988-0107
Ph. 1-800-45-PUMPS
D & F Distributors, Inc.
(B) 1144 Indy Court
Evansville, IN 47711
Ph. 812/867-2441
Ph. 1-800-45-PUMPS

⑬ John Henry Foster Co., Inc.
(B) 4700 Lebourget Drive
St. Louis, MO 63134-0820
Ph. 314/427-0600
Ph. 1-800-444-0522

⑭ Isaacs Fluid Power Equipment Company
(B) 8746 East 33rd Street
Indianapolis, IN 46226
Ph. 317/898-3486
Isaacs Fluid Power Equipment Company
FL Wayne, IN
Ph. 219/747-9804

Isaacs Fluid Power Equipment Company
(B) 1023 E. Fourth St.
Dayton, OH 45402
Ph. 513/228-7774
Isaacs Fluid Power Equipment Company
(B) 1840 Amberlawn Dr.
Cincinnati, OH 45237
Ph. 513/761-8855

Isaacs Fluid Power Equipment Company
(B) 929 Eastwind Drive, Suite 205
Westerville, OH 43081
Ph. 614/895-8540

⑮ Skarda Equipment Co., Inc.
(B) 2563 Farnam
Omaha, NE 68131
Ph. 1-800-228-9750
Ph. 402/422-0430

Skarda Equipment Co., Inc.
(B) 3545 Third Ave.
Marion, IA 52302
Ph. 1-800-228-9750
Skarda Equipment Co., Inc.
Des Moines, IA
Ph. 1-800-228-9750

Skarda Equipment Co., Inc.
(B) 10139 Kaw Dr.
Edwardsville, KS 66113
Ph. 1-800-228-9750

Skarda Equipment Co., Inc.
(B) 313 N. Mathewson
Wichita, KS 67214
Ph. 1-800-228-9750

⑯ D & L Pumps, Inc.
(B) 2845 Sharon Street
Kenner, LA 70062
Ph. 504/467-2490

⑰ William H. Nash Co., Inc.
(B) 23910 Freeway Park Drive
Farmington Hills, MI 48335
Ph. 810/477-5800

William H. Nash Co., Inc.
(B) 4134 36th Street S.E.
Grand Rapids, MI 49512
Ph. 616/949-4900

William H. Nash Co., Inc.
Flushing, MI
Ph. 810/732-7272

⑱ Midwest Machine Tool Supply
230 Commerce Circle South
Minneapolis, MN 55432
Ph. 612/571-3550
Ph. 1-800-327-9523

⑲ Kinequip, Inc.
(B) 365 Old Niagara Falls Blvd.
Buffalo, NY 14228-1636
Ph. 716/694-5000
Ph. 1-800-982-8894

Kinequip, Inc.
Johnstown, NY
Ph. 1-800-982-8894
Kinequip, Inc.
(B) Rochester, NY
Ph. 716/272-1590
Ph. 1-800-982-8894

Kinequip, Inc.
(B) Syracuse, NY 13211
Ph. 315/458-4115
Ph. 1-800-982-8894

⑳ Hydraulic & Pneumatic Sales
(B) 11100 Park Charlotte Blvd.
Charlotte, NC 28241
Ph. 704/588-3234

㉑ RAF Fluid Power, Inc.
(B) 23775 Mercantile Road
Cleveland, OH 44122-5990
Ph. 216/464-8990

㉒ Southwestern Controls
(B) 9912 B. East 45th Place
Tulsa, OK 74146-4752
Ph. 918/663-6777
Ph. 1-800-658-1570

Southwestern Controls
(B) 6720 Sands Point
Houston, TX 77074
Ph. 713/777-2626
Ph. 1-800-444-9368

Southwestern Controls
(B) 8808 Sovereign Flow
Dallas, TX 75247
Ph. 214/638-4266
Ph. 1-800-444-9367

Southwestern Controls
(B) 859 Isom Road
San Antonio, TX 78216-4035
Ph. 210/340-4111

㉔ Allegheny Fluid Power, Inc.
(B) 112 Douglas Road
Sewickley, PA 15143
Ph. 412/367-5894

㉕ Mesa Equipment & Supply Company
(B) 3820 Commons, N.E.
Albuquerque, NM 87109
Ph. 505/345-0284

Mesa Equipment & Supply Company
(B) 1342 Lomaland Drive
El Paso, TX 79935
Ph. 915/594-1414

㉖ C.A. Weaver Co., Inc.
(B) 2420 Grenoble Road
Richmond, VA 23294
Ph. 804/672-6501

C.A. Weaver Co., Inc.
(B) 7562 Hi Tech Rd.
Roanoke, VA 24019
Ph. 703/563-9761

C.A. Weaver Co., Inc.
(B) 2430 Alabama Avenue
Norfolk, VA 23513
Ph. 804/857-8700

㉗ Air-Oil Products Corp.
(B) 6353 Sixth Ave. South
Seattle, WA 98108-3437
Ph. 206/767-7750
Ph. 1-800-282-2672
Ph. 206/762-4736

Air-Oil Products Corp.
(B) 2400 E. Burnside St.
Portland, OR 97214
Ph. 503/234-0866
Ph. 1-800-242-2672

Air-Oil Products Corp.
(B) 865 Conger Street
Eugene, OR 97401
Ph. 503/485-2022
Ph. 1-800-322-2672

㉘ Fluid System Components Inc.
(B) 11100 Gross St.
Green Bay, WI 54307
Ph. 414/337-0233

Fluid System Components Inc.
(B) 2315 South 170th Street
New Berlin, WI 53151-2701
Ph. 414/827-2700

㉙ J.E.M. Fluid Power, Inc.
(B) 2182 Dam Rd.
West Branch, MI 48661
Ph. 517/345-1180

㉚ GAST
Gast Mfg. Corp.
(C) 2300 Highway M-139
Benton Harbor, MI 49023-0097
Ph. 616/926-6171

㉛ C & F Machinery
(A) 91-060 Hanua Street
Kapolei, Hawaii 96707-1777
Ph. 808/682-1541

㉜ Games Industries, Inc.
(B) 6317 Nielson Way
Anchorage, AK 99518
Ph. 907/562-2933

㉝ CANADA
ONTARIO
Wainbee Ltd.
Windsor
Ph. 1-800-265-0929

Wainbee Ltd.
(B) 1590 Liverpool Court
Ottawa, Ontario K1B 4L2
Ph. 613/744-1720

Wainbee Ltd.
(A,D) 5789 Coopers Ave.
Mississauga, Ontario L4Z 3S6
Ph. 905/568-1700
Fax: 905/568-0083

Wainbee Ltd.
(B) Unit 14
65 Trillium Park Place
Kitchener, Ont. N2E 1X1
Ph. 519/748-5391

Wainbee Ltd.
(B) 1909 Oxford Street East, Unit 45
London, Ont. N5V 4L9
Ph. 519/451-6266
Fax: 519/451-5566

QUEBEC
Wainbee Ltd.
(A,D) 215 Brunswick Blvd.
Pointe Claire, P.Q. H9R 4R7
Ph. 514/697-8810

Wainbee Ltd.
(B) 1990 Quest Blvd. Charest
Quebec City, P.Q. G1N 4K3
Ph. 418/683-1956

Wainbee Ltd.
(B) 1932 St. Paul Blvd.
Chicoutimi, P.Q. G7K 1H2
Ph. 418/698-4884

BRITISH COLUMBIA
Wainbee Ltd.
(B) 2231 Vauxhall Place
Richmond, B.C. V6V 1Z5
Ph. 604/278-4288
Ph. 1-800-663-9829

ALBERTA
Wainbee Ltd.
(B) 10336 59th Avenue
Edmonton, Alta. T6H 1E6
Ph. 403/434-9528

Wainbee Ltd.
(B) 7407 44th St. S.E.
Calgary, Alta. T2C 3C8
Ph. 403/236-1133

MANITOBA
Wainbee Ltd.
(B) 1393 Border St. #4
Winnipeg, Man. R3H 0N1
Ph. 1-800-663-1393

MARTIME PROVINCES
Wainbee Ltd.
(B) 10 Thornhill Drive, Suite #5
Dartmouth, Nova Scotia
Halifax B3B 1S1
Ph. 902/468-1787
Ph. 1-800-667-1787

SASKATOON
Wainbee Ltd.
437 34th Street
Saskatoon, Sask. S4S 0S9
Ph. 306/552-1433

NORTH BAY
Wainbee Ltd.
1954 Main Street West
North Bay, Ont. P1B 8K5
Ph. 705/472-4244
Ph. 1-800-461-9534



CONVERSION CHARTS

PRESSURE CONVERSION TABLE

Lbs. Per Sq. Inch	Atmospheres	Inches of Mercury	Millimeters of Mercury	Inches of Water	Meters of Water	Milli Bars	Kilopascals
1	.0680	2.036	51.71	27.73	.7037	69.0	6.895
14.70	1	29.92	760	407	10.33	1013.3	101.36
.4912	.0334	1	25.4	13.6	.3452	33.86	3.387
.0193	.001315	.03937	1	.5358	.0136	1.33	.13307
.0361	.00246	.0735	1.868	1	.0254	2.49	.24891
1.422	.0967	2.895	73.55	39.37	1	97.98	9.8047
14.50	.0009869	.02953	.750	4018	.01021	1	.09998
.145	.00986	.29529	7.4996	4.0174	.10206	10.01	1

VOLUME FLOW CONVERSION TABLE

cfm	cfh	gpm	m ³ h	l/s
1	60	7.4805	1.6990	.47195
1/60	1	.12468	.02832	.007866
.13368	8.0208	1	.22712	.06309
.58858	35.315	4.4029	1	1/3.6
2.1189	127.13	15.850	3.6	1

Power and Heat Flow Conversion Table

hp(U.S.)	ft.lb/min	Btu/hr	Btu/min	W	kcal/min
1	33000	2544.4	42.407	745.70	10.686
.000030303	1	.07710	.001285	.02260	.0003238
.0003930	12.969	1	1/60	.29307	.004200
.02358	778.17	60	1	17.584	.25200
.00134	44.254	3.4121	.05687	1	.01433
.09358	3088.0	238.10	3.9683	69.780	1

Temperature Conversion Chart

°C = $\frac{5}{9} (°F - 32)$

Absolute Kelvin = °C + 273.15

°F = (°C) + 32

Rankine °F = +459.67

TABLE EXAMPLE:

To Convert 100 °C to °F look up 100 read right

To Convert 100 °F to °C look up to 100 read left

to °F	From	to °C	to °F	From	to °C	to °F	From	to °C
-148.0	-100	-73.33	+50.00	+10	-12.22	161.6	72	22.22
-130.0	-90	-67.78	+53.6	+12	-11.11	165.2	74	23.33
-112.0	-80	-62.22	+57.2	+14	-10.00	168.8	76	24.44
-94.0	-70	-56.67	+60.8	+16	-8.89	172.4	78	25.56
-76.0	-60	-51.11	+64.4	+18	-7.78	176.0	80	26.67
-58.0	-50	-45.56	+68.0	+20	-6.67	179.6	82	27.78
-40.0	-40	-40.00	+71.6	+22	-5.56	183.2	84	28.89
-36.4	-38	-38.89	+75.2	+24	-4.44	186.8	86	30.00
-32.8	-36	-37.78	+78.8	+26	-3.33	190.4	88	31.11
-29.2	-34	-36.67	+82.4	+28	-2.22	194.0	90	32.22
-25.6	-32	-35.56	+86.0	+30	-1.11	197.6	92	33.33
-22.0	-30	-34.44	+89.6	+32	0.00	201.2	94	34.44
-18.4	-28	-33.33	+93.2	+34	+1.11	204.8	96	35.56
-14.8	-26	-32.22	+96.8	+36	+2.22	208.4	98	36.67
-11.2	-24	-31.11	+100.4	+38	+3.33	212.0	100	37.78
-7.6	-22	-30.00	+104.0	+40	+4.44	230.0	110	43.33
-4.0	-20	-28.89	107.6	42	5.56	248.0	120	48.89
-0.4	-18	-27.78	111.2	44	6.67	266.0	130	54.44
+3.2	-16	-26.67	114.2	46	7.78	284.0	140	60.00
+6.8	-14	-25.56	118.4	48	8.89	302.0	150	65.56
+10.4	-12	-24.44	122.0	50	10.00	320.0	160	71.11
+14.0	-10	-23.33	125.6	52	11.11	338.0	170	76.67
+17.6	-8	-22.22	129.2	54	12.22	356.0	180	82.22
+21.2	-6	-21.11	132.8	56	13.33	374.0	190	87.78
+24.8	-4	-20.00	136.4	58	14.44	392.0	200	93.33
+28.4	-2	-18.89	140.0	60	15.56	410.0	210	98.89
+32.0	0	-17.78	143.6	62	16.67	428.0	220	104.44
+35.6	+2	-16.67	147.2	64	17.78	446.0	230	110.00
+39.2	+4	-15.56	150.8	66	18.89	464.0	240	115.56
+42.8	+6	-14.44	154.4	68	20.00	482.0	250	121.11
+46.4	+8	-13.33	158.0	70	21.11			

APPENDIX B

DATA COLLECTION SHEETS

