

# LOAN DOCUMENT

PHOTOGRAPH THIS SHEET

①

INVENTORY

DTIC ACCESSION NUMBER

LEVEL

Part II

Draft Interim Test Results Rpt ...

DOCUMENT IDENTIFICATION

Nov 92

**DISTRIBUTION STATEMENT A**  
Approved for Public Release  
Distribution Unlimited

DISTRIBUTION STATEMENT

ACCESSION FOR	
NTIS	GRAM
DTIC	TRAC
UNANNOUNCED	
JUSTIFICATION	
BY	
DISTRIBUTION/	
AVAILABILITY CODES	
DISTRIBUTION	AVAILABILITY AND/OR SPECIAL
A-1	

DISTRIBUTION STAMP

DATE ACCESSIONED

DATE RETURNED

20001130 038

DATE RECEIVED IN DTIC

REGISTERED OR CERTIFIED NUMBER

PHOTOGRAPH THIS SHEET AND RETURN TO DTIC-FDAC

H  
A  
N  
D  
L  
E  
  
W  
I  
T  
H  
  
C  
A  
R  
E

# PART II

## DRAFT INTERIM TEST RESULTS REPORT

*For*

**BASE EXCHANGE SERVICE STATION  
UNDERGROUND STORAGE TANK AREA  
*Vandenberg Air Force Base, California***

*Prepared for*

**AIR FORCE CENTER FOR  
ENVIRONMENTAL EXCELLENCE  
*Brooks Air Force Base, Texas***

*and*

**730 CES / CEVR VANDENBERG AFB, California**

NOVEMBER 1992

211.1478/01/YO

*Prepared by*

**ENGINEERING-SCIENCE**

**DESIGN • RESEARCH • PLANNING**

199 SOUTH LOS ROBLES AVENUE • P.O. BOX 7056 • PASADENA, CALIFORNIA 91101

ES  
ENGINEERING-SCIENCE

AQM01-01-0364

### DEFENSE TECHNICAL INFORMATION CENTER REQUEST FOR SCIENTIFIC AND TECHNICAL REPORTS

Title AFCEE Collection

**1. Report Availability** (Please check one box)

- This report is available. Complete sections 2a - 2f.
- This report is not available. Complete section 3.

**2a. Number of Copies Forwarded**

1 each

**2b. Forwarding Date**

July/2000

**2c. Distribution Statement** (Please check ONE box)

DoD Directive 5230.24, "Distribution Statements on Technical Documents," 18 Mar 87, contains seven distribution statements, as described briefly below. Technical documents MUST be assigned a distribution statement.

- DISTRIBUTION STATEMENT A: Approved for public release. Distribution is unlimited.
- DISTRIBUTION STATEMENT B: Distribution authorized to U.S. Government Agencies only.
- DISTRIBUTION STATEMENT C: Distribution authorized to U.S. Government Agencies and their contractors.
- DISTRIBUTION STATEMENT D: Distribution authorized to U.S. Department of Defense (DoD) and U.S. DoD contractors only.
- DISTRIBUTION STATEMENT E: Distribution authorized to U.S. Department of Defense (DoD) components only.
- DISTRIBUTION STATEMENT F: Further dissemination only as directed by the controlling DoD office indicated below or by higher authority.
- DISTRIBUTION STATEMENT X: Distribution authorized to U.S. Government agencies and private individuals or enterprises eligible to obtain export-controlled technical data in accordance with DoD Directive 5230.25, Withholding of Unclassified Technical Data from Public Disclosure, 6 Nov 84.

**2d. Reason For the Above Distribution Statement** (in accordance with DoD Directive 5230.24)

**2e. Controlling Office**

HQ AFCEE

**2f. Date of Distribution Statement Determination**

15 Nov 2000

**3. This report is NOT forwarded for the following reasons.** (Please check appropriate box)

- It was previously forwarded to DTIC on ..... (date) and the AD number is .....
- It will be published at a later date. Enter approximate date if known. ....
- In accordance with the provisions of DoD Directive 3200.12, the requested document is not supplied because: .....

Print or Type Name

Laura Peña

Telephone

210-536-1431

Signature

Laura Peña

(For DTIC Use Only)

AD Number

MO1-01-0364

**PART II**  
**DRAFT INTERIM PILOT TEST RESULTS REPORT FOR**  
**BASE EXCHANGE SERVICE STATION**  
**UNDERGROUND STORAGE TANK AREA**  
**VANDENBERG AFB, CALIFORNIA**

**Prepared for:**

**AIR FORCE CENTER FOR ENVIRONMENTAL EXCELLENCE**  
**BROOKS AFB, TEXAS**  
**AND**  
**730 CES/CEVR VANDENBERG AFB, CALIFORNIA**

**NOVEMBER 1992**

**Prepared by:**

**ENGINEERING-SCIENCE, INC.**  
**199 S. LOS ROBLES AVENUE**  
**PASADENA, CALIFORNIA 91101**

## TABLE OF CONTENTS

1.0	Base Exchange UST Area.....	1
1.1	Pilot Test Design .....	1
	1.1.1 Air-Injection Vent Well .....	1
	1.1.2 Monitoring Points.....	6
	1.1.3 Blower Unit.....	6
1.2	Soil and Soil Gas Sampling Results.....	6
1.3	Exceptions to Test Protocol.....	9
1.4	Test Results .....	11
	1.4.1 Initial Soil Gas Chemistry.....	11
	1.4.2 Soil Gas Permeability .....	11
	1.4.3 Oxygen Influence.....	12
	1.4.4 In Situ Respiration Rates.....	13
	1.4.5 Potential Air Emissions.....	18
2.0	Recommendations for Expanded Pilot Test .....	18
	2.1 Drilling .....	20
	2.2 Piping and Air Injection Trench Excavations.....	20
	2.2.1 Air Injection Trenches .....	23
	2.2.2 Auxiliary Piping Trenches .....	23
	2.2.3 Photographs .....	23
	2.2.4 Utilities.....	23
	2.3 Soil Sampling Procedures .....	23
	2.4 Extraction Well Construction.....	23
	2.4.1 Well Casing.....	23
	2.4.2 Well Screen.....	24
	2.4.3 Filter Pack and Natural Pack.....	24
	2.4.4 Bentonite Seal .....	24
	2.4.5 Grout Seal/Grouting.....	24
	2.4.6 Surface Completion of VEWs and VMPs.....	24
	2.5 Piping Construction.....	25
	2.5.1 Air Injection Piping .....	25
	2.5.2 Vacuum and Injection Line Piping .....	25
	2.6 Decontamination Procedures.....	25
	2.6.1 General Decontamination Procedures.....	25
	2.6.2 Drilling Equipment.....	26
	2.6.3 Sampling Equipment.....	26

**TABLE OF CONTENTS (CONTINUED)**

2.7	Asphalt/Pavement Patching.....	26
	2.7.1 Materials.....	26
	2.7.2 Aggregate and Asphalt Placement.....	26
2.8	Extraction Equipment .....	27
	2.8.1 Vacuum Blower.....	27
	2.8.2 Instrumentation.....	27
	2.8.3 Vapor Treatment Unit.....	28
2.9	Regulatory Requirements and Permitting .....	28
2.10	Summary .....	29
2.11	Cost Estimate.....	29
2.12	Schedule.....	29
3.0	References .....	30

## TABLES

No.	Title	Page
1.1	Soil and Soil Gas Analytical Results.....	10
1.2	Initial Soil Gas Chemistry.....	11
1.3	Pressure Response Air Permeability Test .....	12
1.4	Steady-State Influence of Air Injection at Vent Well on Monitoring Point Oxygen Levels.....	13
1.5	1 Hour Vapor Extraction Test Sample Analytical Results .....	18

## FIGURES

No.	Title	Page
1.1	Site Location BXSS UST Area.....	2
1.2	As Built Vent Wells and Vapor Monitoring Point Locations, BXSS UST Area .....	3
1.3	Typical Geological Profile.....	4
1.4	Injection/Vent Well (BXS-MW-12) Construction Detail BXSS UST Area .....	5
1.5	Monitoring Point Construction Detail BXSS UST Area.....	7
1.6	Blower System Instrumentation Diagram for Air Injection BXSS UST Area.....	8
1.7	Respiration Test: Monitoring Point VA1-MPD .....	14
1.8	Respiration Test: Monitoring Point BXS-MW-7.....	15
1.9	Respiration Test: Monitoring Point BXS-MW-5.....	16
1.10	Respiration Test Oxygen and Helium Concentrations Monitoring Point VA1-MPD .....	17
2.1	Expanded Bioventing System Plan BXSS UST Area.....	19
2.2	Typical Vapor Extraction Well.....	21
2.3	Extended Bioventing System Conceptual Details .....	22

**PART II**  
**DRAFT**  
**INTERIM PILOT TEST RESULTS**

An initial bioventing pilot test was completed at the Base Exchange Service Station Underground Storage Tank (BXSS UST) area on Vandenberg Air Force Base, California during the period of 10 to 17 September 1992. The purpose of Part II is to describe the results of the initial pilot test at the site and to make specific recommendations for extended testing to determine the long-term impact of bioventing on site contaminants. Descriptions of the history, geology, and contamination at the BXSS UST area are contained in Part I, the Test Work Plan.

**1.0 BASE EXCHANGE UST AREA**

**1.1 Pilot Test Design**

Installation of vapor monitoring points (MPs) and a background monitoring point (BG) in and around the BXSS UST area began on 10 September 1992, and was completed on 11 September 1992. Drilling, installation and soil sampling were directed by Mr. Larry Dudus, the Engineering-Science, Inc. (ES) site manager. The following sections describe the final design and installation of the bioventing pilot test system on this site.

Four MPs were installed at the site. A blower unit was temporarily installed on the existing groundwater monitoring well BXS-MW-12 which was used as the vent well (VW). Figures 1.1, 1.2, and 1.3 depict the actual locations and vertical profiles of the VW and MPs completed at the site. A BG for this site was constructed approximately 145 feet southeast of the site.

Soils on this site were fine to medium sand from the surface to groundwater with minor clay layers of less than 1 inch at a depth of approximately 2.5 and 5.7 feet. Groundwater occurred at a depth of 8.7 feet in the VW.

**1.1.1 Air-Injection Vent Well**

The existing groundwater monitoring well BXS-MW-12 was used as the air injection VW. Figure 1.4 shows construction detail for the VW. The screened interval penetrates approximately 14 feet into the groundwater. Approximately 4 feet of screen extends above the water table into contaminated soil. The VW was constructed using 4-inch-diameter, Schedule 40 PVC casing with 18 feet of screen installed from 4.7 to 22.7 feet below ground surface. The annular space between the well casing and borehole was filled with No. 16 silica sand from the bottom of the

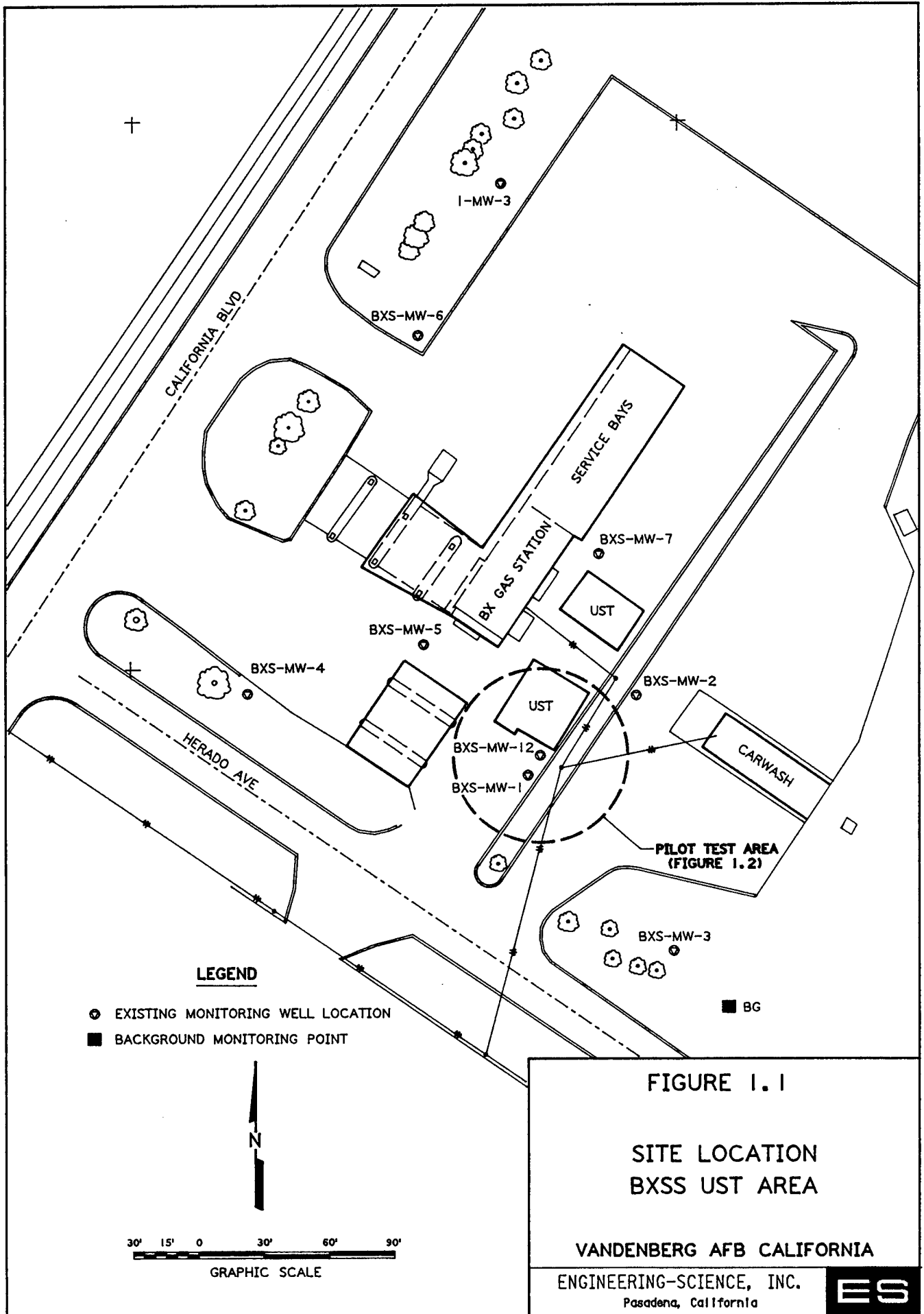

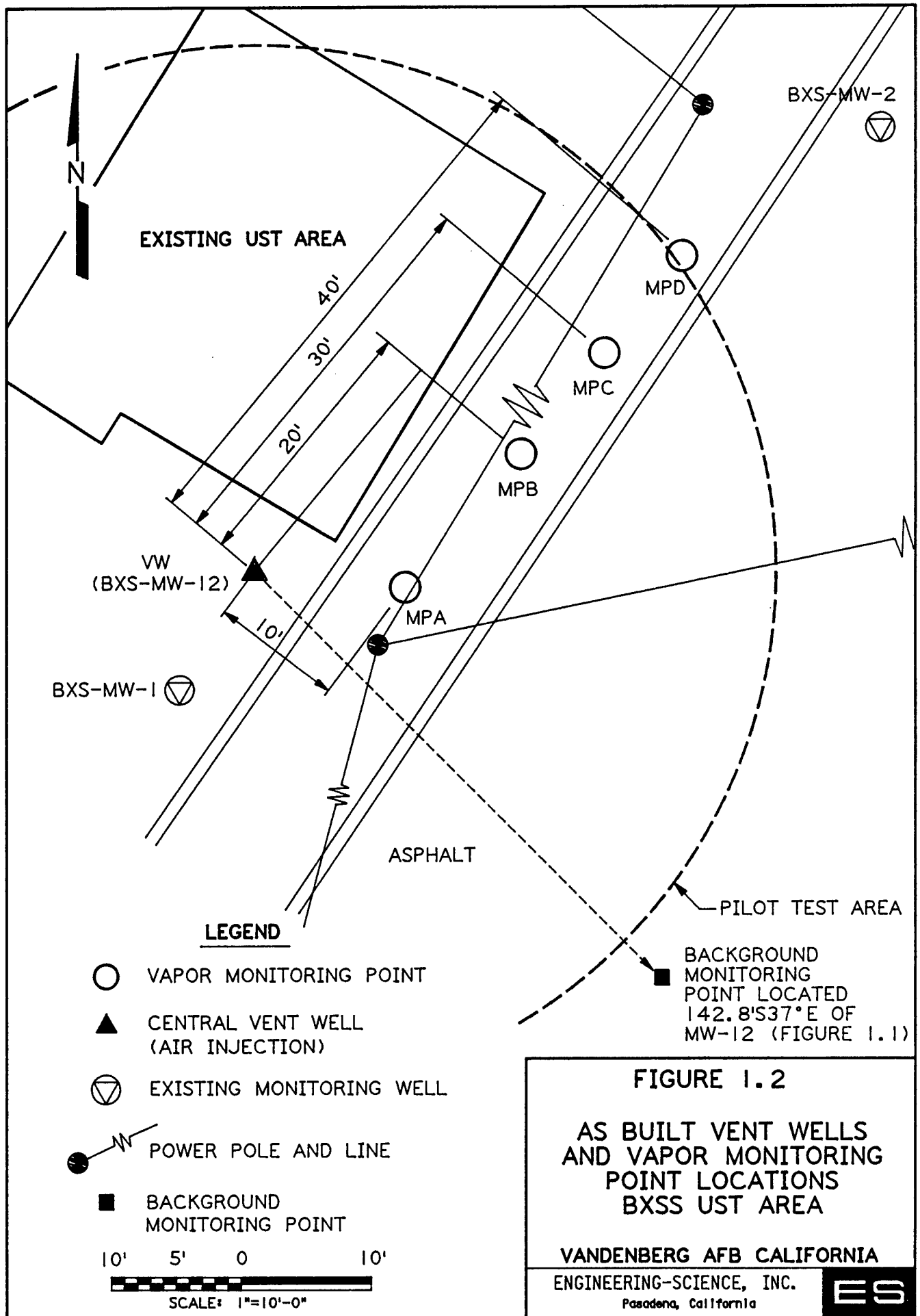

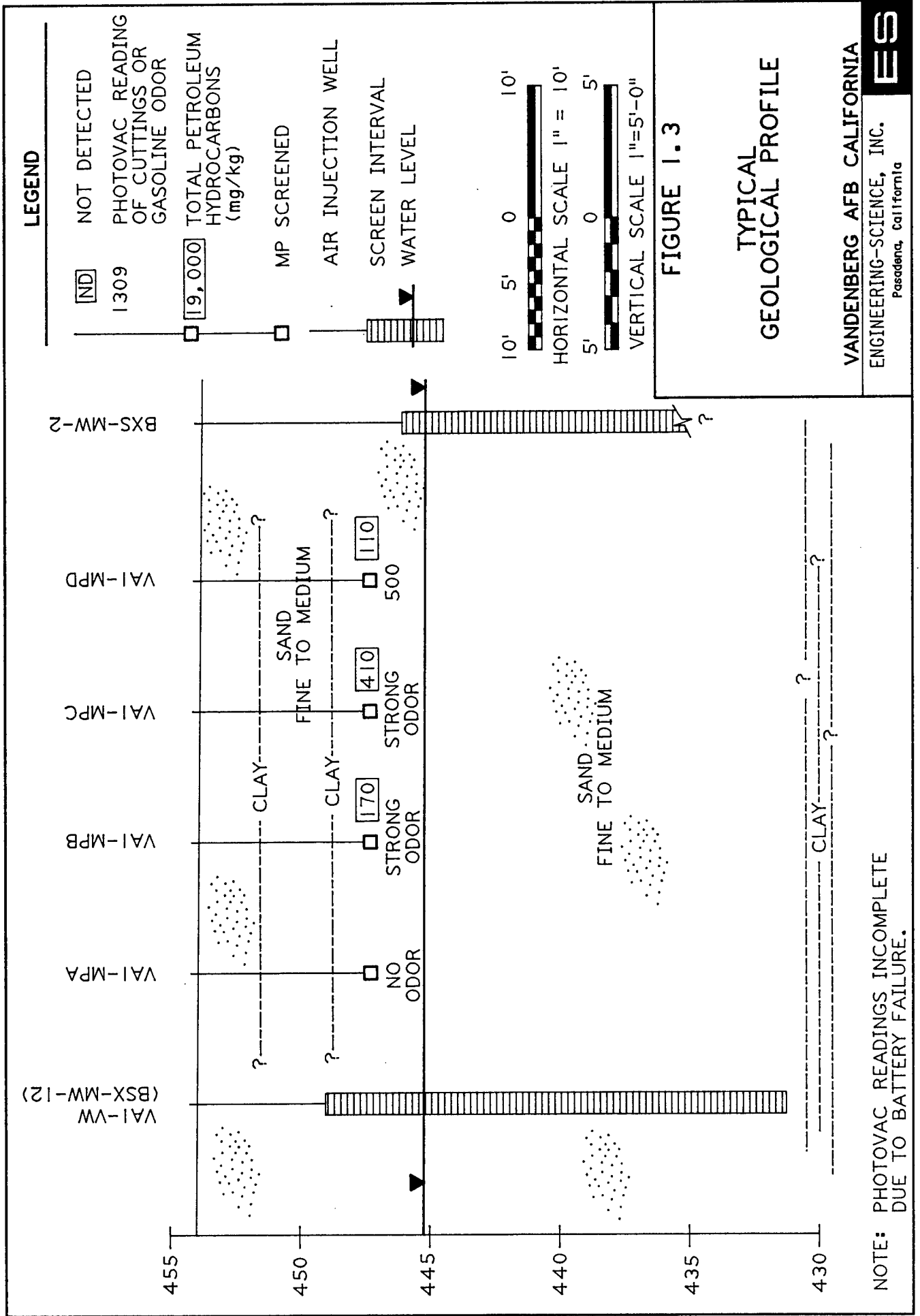

2" DIA SCH 40 PVC  
HEADER SLOPED  
TO WELL

FROM BLOWER

CONCRETE COLLAR

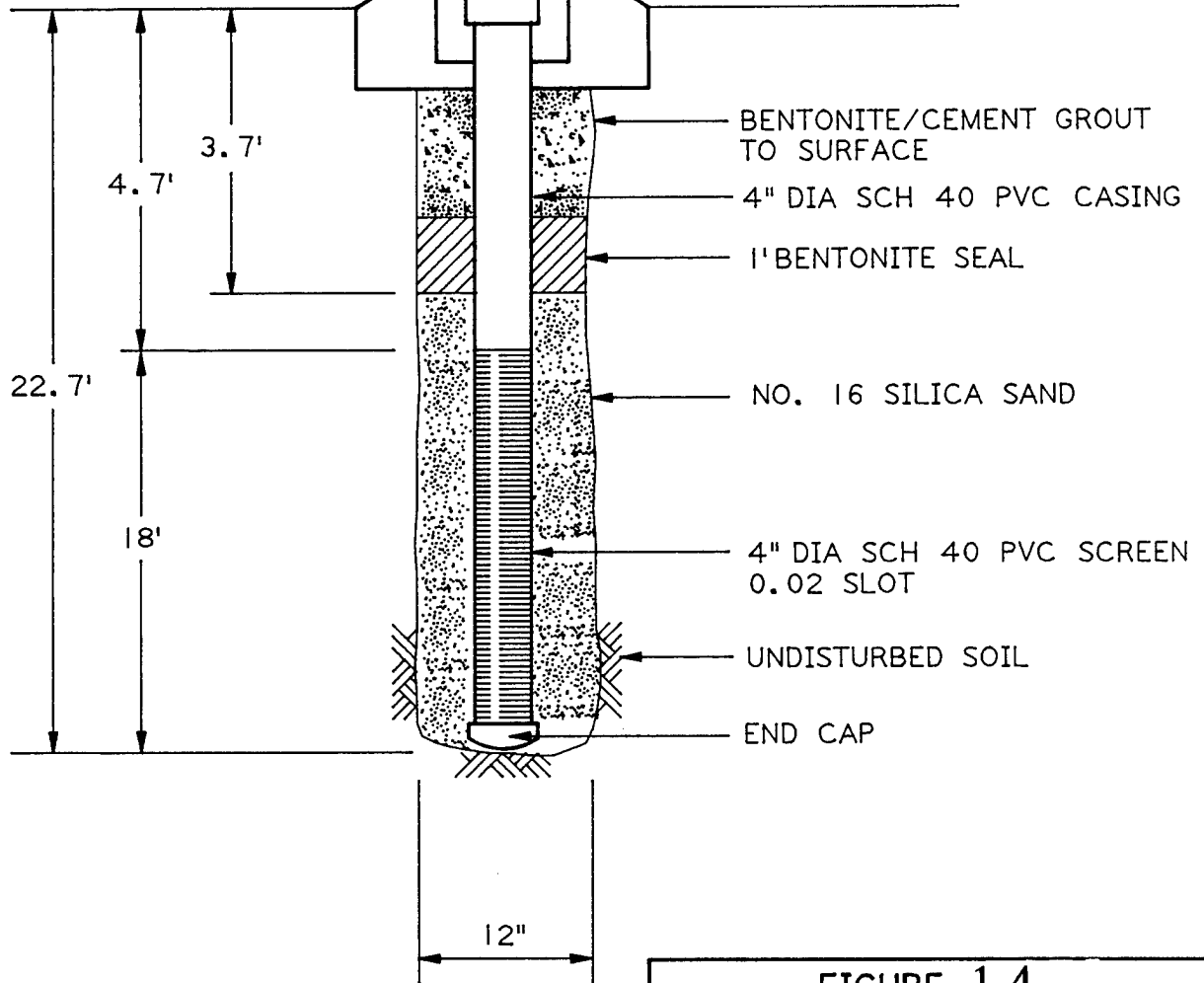

FIGURE 1.4

INJECTION/VENT WELL  
(BXS-MW-12)  
CONSTRUCTION DETAIL  
BXSS UST AREA

VANDENBERG AFB CALIFORNIA

ENGINEERING-SCIENCE, INC.  
Pasadena, California

ES

borehole to approximately one foot above the well screen. Bentonite pellets were placed 1.0 feet above the sand, followed by 2.7 feet of bentonite cement slurry. The top of the well was completed with a 4-inch-diameter locking cap and an 8-inch flush mount box. To connect the blower to the wellhead during the pilot test, the VW was fitted with a 4-inch to 2-inch Fernco® couple inside the flush mount box.

### 1.1.2 Monitoring Points

The MP screens were installed approximately 6.5 feet below ground surface. The four MPs and one BG at this site were constructed as shown in Figure 1.5. Each point was constructed using a 6-inch section of 1/2-inch PVC well screen and a 1/2-inch PVC riser pipe extending to the surface. At the top of each riser, a ball valve and 1/4-inch hose barb were installed. The top of each MP was completed with a 12-inch flush-mounted, metal well protector set in a concrete base. A thermocouple was installed at 6.5 feet in MPB to measure soil temperature. Each MP was labeled as shown in Figures 1.1 and 1.2.

### 1.1.3 Blower Unit

A portable 1-horsepower regenerative blower unit was used at the site for the initial pilot test. Figure 1.6 shows a schematic diagram of the blower system used. Instead of the standard extended pilot test, Vandenberg AFB has requested an expanded scale extended pilot test where the gasoline contaminated soil beneath the entire base exchange service station will be treated for 1 year. A description of the blower for the expanded system is included in Section 2.

## 1.2 Soil and Soil Gas Sampling Results

Hydrocarbon contamination in the MPs was generally observed from 6 feet below ground surface to the MP's total depth of 7.2 feet. It appears that contamination migrated vertically to the water table, then laterally due to seasonal water level fluctuations and groundwater movement. Contamination was identified based on visual appearance, odor, and volatile organic compound (VOC) field screening results. Some heavily contaminated soils were stained dark gray in color and had a strong gasoline odor. Soil samples were screened for VOCs using a photoionization detector (PID) to determine the presence of contamination. PID battery failure prevented all samples from being screened. PID readings and sample odor were used to select soil samples for laboratory analysis.

Three soil samples were collected during the installation of the MPs. Sampling procedures followed those outlined in the protocol document. One sample was collected from the interval of highest apparent contamination in VA1-MPB, VA1-MPC and VA1-MPD. Soil samples were analyzed for the following;

Analytical Parameter	Method
Total recoverable petroleum hydrocarbons (TRPH)	E 418.1
Benzene, toluene, ethyl benzene, xylenes (BTEX)	SW8020

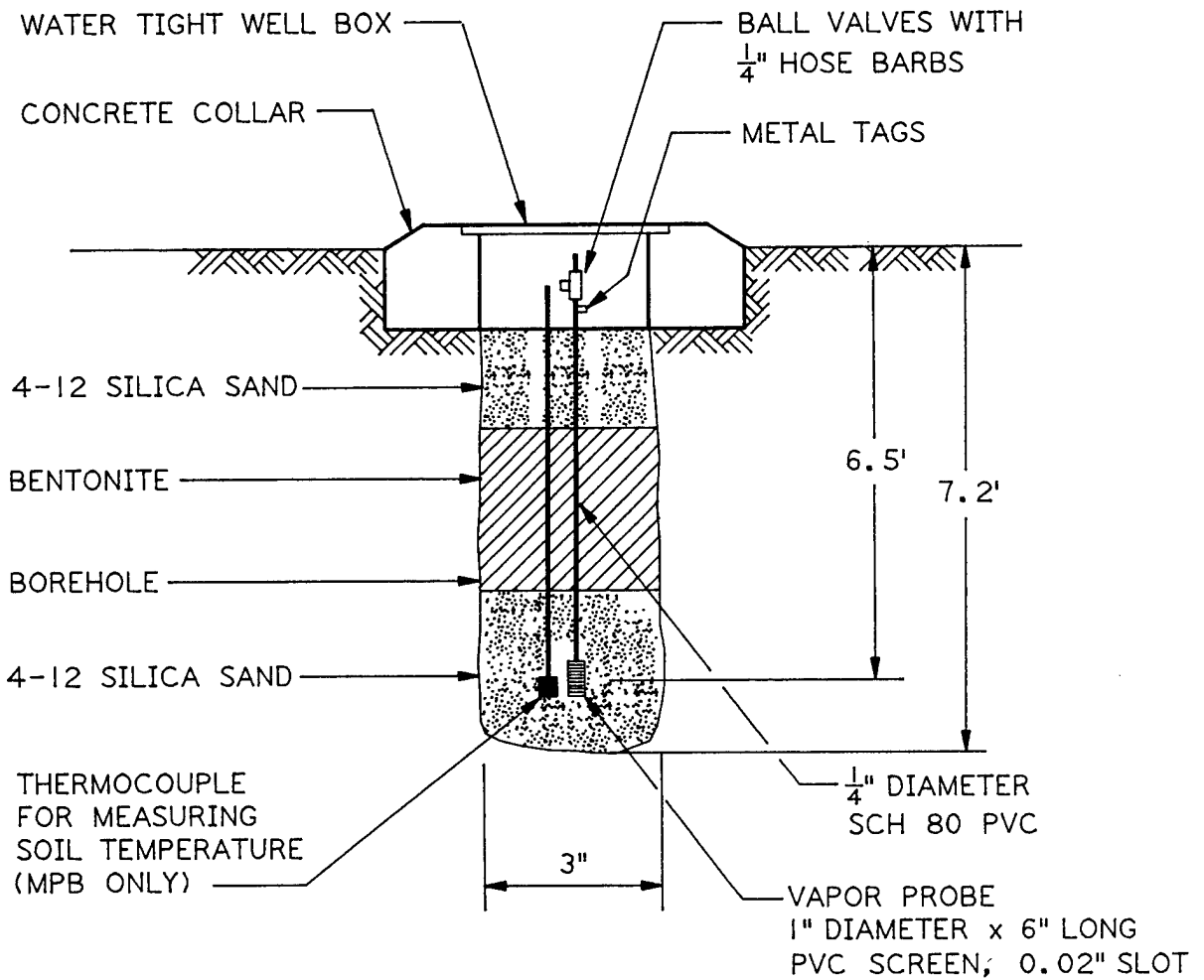

FIGURE 1.5

MONITORING POINT  
CONSTRUCTION DETAIL  
BXSS UST AREA

VANDENBERG AFB CALIFORNIA

ENGINEERING-SCIENCE, INC.  
Denver, Colorado

ES

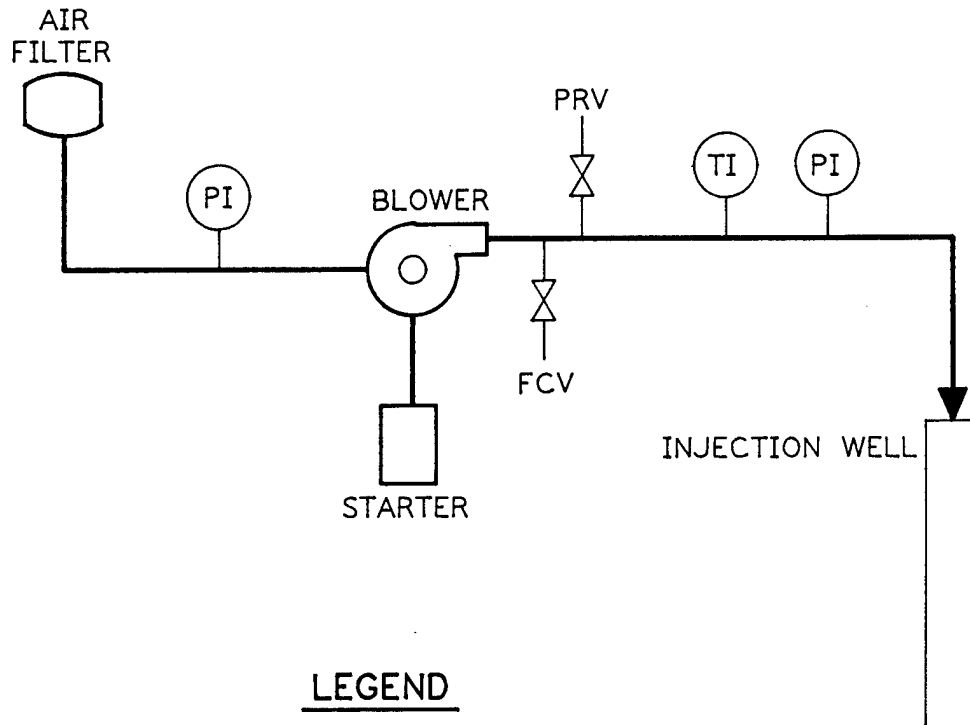

LEGEND

- PI
 PRESSURE INDICATOR (INCHES OF H<sub>2</sub>O)
- TI
 TEMPERATURE INDICATOR (FAHRENHEIT)
- FCV      MANUAL FLOW CONTROL VALVE
- PRV      AUTOMATIC PRESSURE RELIEF VALVE

FIGURE 1.6

BLOWER SYSTEM  
 INSTRUMENTATION DIAGRAM  
 FOR AIR INJECTION  
 BXSS UST AREA

VANDENDERG AFB CALIFORNIA

ENGINEERING-SCIENCE, INC.  
 Pasadena, California



Soil moisture	ASTM D2216
pH	SW9045
Particle size	UCM
Alkalinity	A403
Total iron	SW7380
Total Kjeldahl nitrogen	E351.2
Total phosphorus	E365.3

Samples for TRPH and BTEX analysis were collected using an AMS® soil core sampler containing brass tube liners. Soil samples collected in the brass tubes for TRPH and BTEX analyses were immediately trimmed and the ends sealed with Teflon sheets held in place by plastic caps. Soil samples collected for physical parameter analyses were placed into glass sample jars as specified in the bioventing field sampling plan.

Despite high PID readings and gasoline odor in MPB, MPC and MPD, only MPD had O<sub>2</sub> readings at or below 2 percent. For this reason existing groundwater monitoring wells BXS-MW-5 and BXS-MW-7 with approximately 3.5 feet of screen in contaminated soil above the water table were used for the respiration test. Therefore, instead of collecting soil gas samples from the MPs only, soil gas samples were collected using SUMMA® canisters from the VW (BXS-MW-12), VA1-MPD, and BSX-MW-7. Before sampling, the wells and MPs were completely purged as described in the protocol document.

Soil samples were shipped via Federal Express® to the ES Berkeley laboratory for chemical and physical analysis. Soil gas samples were shipped via Federal Express® to Air Toxics, Inc. in Rancho Cordova, California for total volatile hydrocarbon (TVH) and benzene, toluene, ethyl benzene, and xylenes (BTEX) analysis. The results of these analyses are provided in Table 1.1.

### 1.3 Exceptions to Test Protocol

The following exceptions to the protocol document occurred at the site.

- Due to PID battery failure, soil samples during MP drilling were screened by odor.
- Despite numerous adjustments, helium injection into VA1-MPD could not be calibrated at 1 percent and ranged from < 1 percent to 3 percent. This varied injection concentration has reduced the accuracy of oxygen diffusion estimates.
- Soil gas samples were analyzed for TPH as jet fuel instead of gasoline.
- Soil gas samples were collected from the VW, BXS-MW-7, and VA1-MPD instead of the VW, VA1-MPA, and VA1-MPD.

**Table 1.1**  
**Base Exchange Service Station UST Area**  
**Soil And Soil Gas Analytical Results**

Analytical Method	Analyte (Units) <sup>a/</sup>	Sample Location-Depth (feet below ground surface)				
		VA1-MPB-6 feet	VA1-MPC-6 feet	VA1-MPD- 5 feet 8 inches	BXS-MW7	VA1-VW (BXS-MW-12)
<b>Soil Hydrocarbons</b>						
E418.1	TRPH (mg/kg)	170	410	110		NA <sup>b/</sup>
SW8020	Benzene (µg/kg)	ND <sup>c/</sup>	ND	ND		NA
	Toluene (µg/kg)	1800	4900	9500		NA
	Ethyl benzene (µg/kg)	2700	5700	6200	NA	
	Xylenes (µg/kg)	22000	69000	46000		NA
<b>Soil Gas Hydrocarbons</b>						
TO-3	TVH (ppmv)			11,000	45,000	2,400
	Benzene (ppmv)			68	400	12
	Toluene (ppmv)			190	61	2.4
	Ethyl benzene (ppmv)			21	60	3.6
	Xylenes (ppmv)			160	240	18
<b>Soil Inorganics</b>						
SW 7380	Iron (mg/kg)	3000	3320	2430		NA
A 403	Alkalinity (mg/kg as CaCO <sub>3</sub> )	ND	ND	60		NA
SW 9045	pH (units)	6.5	6.7	7.5		NA
E351.2	TKN (mg/kg)	59	70	180		NA
E365.3	Phosphates (mg/kg)	95	120	90		NA
<b>Soil Physical Parameters</b>						
ASTM D2216	Moisture (% wt.)	7.2	7.7	5.0		NA
UCM	Gravel (%)	0	0	0		NA
	Sand (%)	63	70	66		NA
	Silt (%)	27	20	20		NA
	Clay (%)	10	10	14		NA

a/ TRPH - total recoverable petroleum hydrocarbons; mg/kg = milligrams per kilogram, ppmv = parts per million, volume per volume;

µg/kg = micrograms per kilogram, TVH = total volatile hydrocarbons;  
 CaCO<sub>3</sub> = calcium carbonate; TKN = total Kjeldahl nitrogen.

b/ NA = Not Analyzed

c/ ND = not detected.

## 1.4 Test Results

### 1.4.1 Initial Soil Gas Chemistry

Prior to initiating any air injection at BXS UST area, all MPs, the BG, BXS-MW-5, and BXS-MW-7 were purged, and initial oxygen, carbon dioxide, and TVH concentrations were sampled using portable gas analyzers, as described in the protocol document (Hinchee et al., 1992). Table 1.2 summarizes the initial soil gas chemistry on this site. These data also demonstrate the relationship between depleted oxygen levels and more contaminated soils. In highly contaminated soils, microorganisms have completely depleted soil gas oxygen supplies. Because BXS-MW-5 and BXS-MW-7 are also located in an asphalt covered area, oxygen diffusion from the atmosphere cannot occur, resulting in zero oxygen levels. In contrast, the background monitoring point (VA1-BG) has near atmospheric levels of oxygen at a depth of 6 feet since little or no oxygen depletion is occurring due to abiotic reactions or non-fuel hydrocarbon degradation. Natural organic and abiotic oxygen uptake should also be absent in the pilot test area.

**Table 1.2**  
**Base Exchange UST Area**  
**Initial Soil Gas Chemistry**

Location	O <sub>2</sub> %	CO <sub>2</sub> %	TVH ppmv	Temp °F
BXS-MW-12	11.0	9.4	870	NA
VA1-MPA	11.6	8.5	210	NA
VA1-MPB	8.2	10.5	3,000	74.7
VA1-MPC	6.0	11.6	1,500	NA
VA1-MPD	1.0	15.0	1,900	NA
BXS-MW-5	0.0	16.0	9,000	NA
BXS-MW-7	0.0	17.0	>10,000	NA
VA1-BG	20.4	1.2	200	NA

### 1.4.2 Soil Gas Permeability

A soil gas permeability test was conducted according to protocol procedures. Air was injected into BXS-MW-12 at a rate of approximately 55 standard cubic feet per minute (scfm) and an absolute well head pressure of 35 inches of water. The

maximum pressure response at each MP is listed in Table 1.3. Due to the rapid response and relatively short time to achieve steady-state conditions (approximately 2 minutes), the steady-state method of determining soil gas permeability was selected. As discussed in the protocol, the dynamic method of determining soil gas permeability that is coded in the Hyperventilate® model is not appropriate for soils which reach steady-state in less than 10 minutes. Using the steady-state method, soil gas permeability was estimated to be a minimum of 5.9 darcys.

**Table 1.3**  
**Base Exchange UST Area**  
**Steady-State Pressure Response**  
**Air Permeability Test**

Monitoring Point	BXS-MW-1	VA1-MPA	VA1-MPB	VA1-MPC	VA1-MPD
Distance From VW in Feet	10.65	9.9	20.1	30.1	40
Time (min)	1	2	130	130	130
Max Press (in inches H <sub>2</sub> O)	0.9	0.9	0.0	0.0	0.0

### 1.4.3 Oxygen Influence

The depth and radius of oxygen increase in the subsurface resulting from air injection in the central VW is the primary design parameter for bioventing systems. Optimization of full-scale and multiple VW systems requires pilot testing to determine the volume of soil which can be oxygenated at a given flow rate and VW screen configuration.

Table 1.4 describes the change in soil gas oxygen levels that occurred during a 17-hour air-injection test. After 6 hours of injecting at 55 scfm into BXS-MW-12, an odor of degraded gasoline was noted around the UST vault lids. A slight positive pressure around this area was also observed. To reduce the risk of migration of vapor towards the service station or other potentially sensitive receptor, the flow rate to the well was reduced by opening a pressure-relief valve. The blower injected air at this reduced rate for 11 more hours.

Despite short-circuiting caused by the UST vault lids and the flow reduction, an increase in O<sub>2</sub> was observed in VA1-MPD, 40 feet from the VW. Based on the full-scale system operating at Eglin AFB, FL, it is anticipated that the radius of oxygen influence for a long-term bioventing system operating at 10 scfm per well will exceed 40 feet. The soils at the Eglin AFB site are also sandy and the contaminated area is also covered with asphalt. Future monitoring at this site during the extended test will better define the treatment radius.

**Table 1.4**  
**Influence of Air Injection at Vent Well**  
**on Monitoring Point Oxygen Levels**

Monitoring Point	Distance from VW (ft)	Depth (ft)	Initial O <sub>2</sub> (%)	Final O <sub>2</sub> (%)
VA1-MPA	9.9	6	11.6	20.0
VA1-MPB	20.1	6	8.2	12.0
VA1-MPC	30.1	6	6.0	10.0
VA1-MPD	40	6	1.0	2.0

#### 1.4.4 In Situ Respiration Rates

*In situ* respiration tests are performed by injecting air (oxygen) into several contaminated MPs and then measuring the biological oxygen uptake over time. As described earlier, existing wells BXS-MW-5 and BXS-MW-7 were used during the *in situ* respiration test due to the lack of low (<2%) O<sub>2</sub> readings in VA1-MPA, VA1-MPB or VA1-MPC. It appears that the soils under this grassy area are receiving adequate oxygen through natural diffusion and do not require forced aeration. The results of *in situ* respiration testing at this site are presented in Figures 1.7-1.9. The oxygen loss at monitoring points A1-MPD, BXS-MW-5, and BXS-MW-7 ranged from 0.003 to 0.005 percent per minute during the initial 4000 minutes of testing.

A helium in air mixture was injected into VA1-MPD. Since helium is a conservative, inert gas, the change in helium concentrations over time can be useful in determining if oxygen diffusion is responsible for a portion of the oxygen lost from each MP. Figure 1.10 compares oxygen utilization and helium retention for monitoring point VA1-MPD. Approximately 87 percent of the helium was lost from the soil test volume during the same 4000 minutes of testing. This estimate is based upon an initial helium concentration of 2.5 percent. However, despite numerous adjustments, the helium injection concentration varied from <1 to 3%. In light of this unsteady input concentration, the actual loss of helium due to diffusion may have been less than the 87 percent estimate. Because helium is approximately 2.8 times more diffusive than oxygen, the estimated fractional loss of oxygen due to diffusion in those soils is approximately 30 percent. Thus, the loss of oxygen due to biodegradation is approximately 30 percent less than the measured rate of .003 to .005 percent per minute. The corrected oxygen utilization rate has been conservatively estimated at .002 to .0035 percent.

Based on oxygen utilization rates observed during the initial 4,000 minutes of respiration testing, an estimated 580 to 990 milligrams (mg) of fuel per kilogram (kg) of soil can be degraded each year on this site. This estimate is based on an average air-filled porosity of 0.15 liters per kilogram of soil, and a conservative ratio of 3.5 mg of oxygen consumed for every 1 mg of fuel biodegraded.

Figure 1.7  
Respiration Test  
Monitoring Point VA1-MPD  
Vandenberg AFB, CA

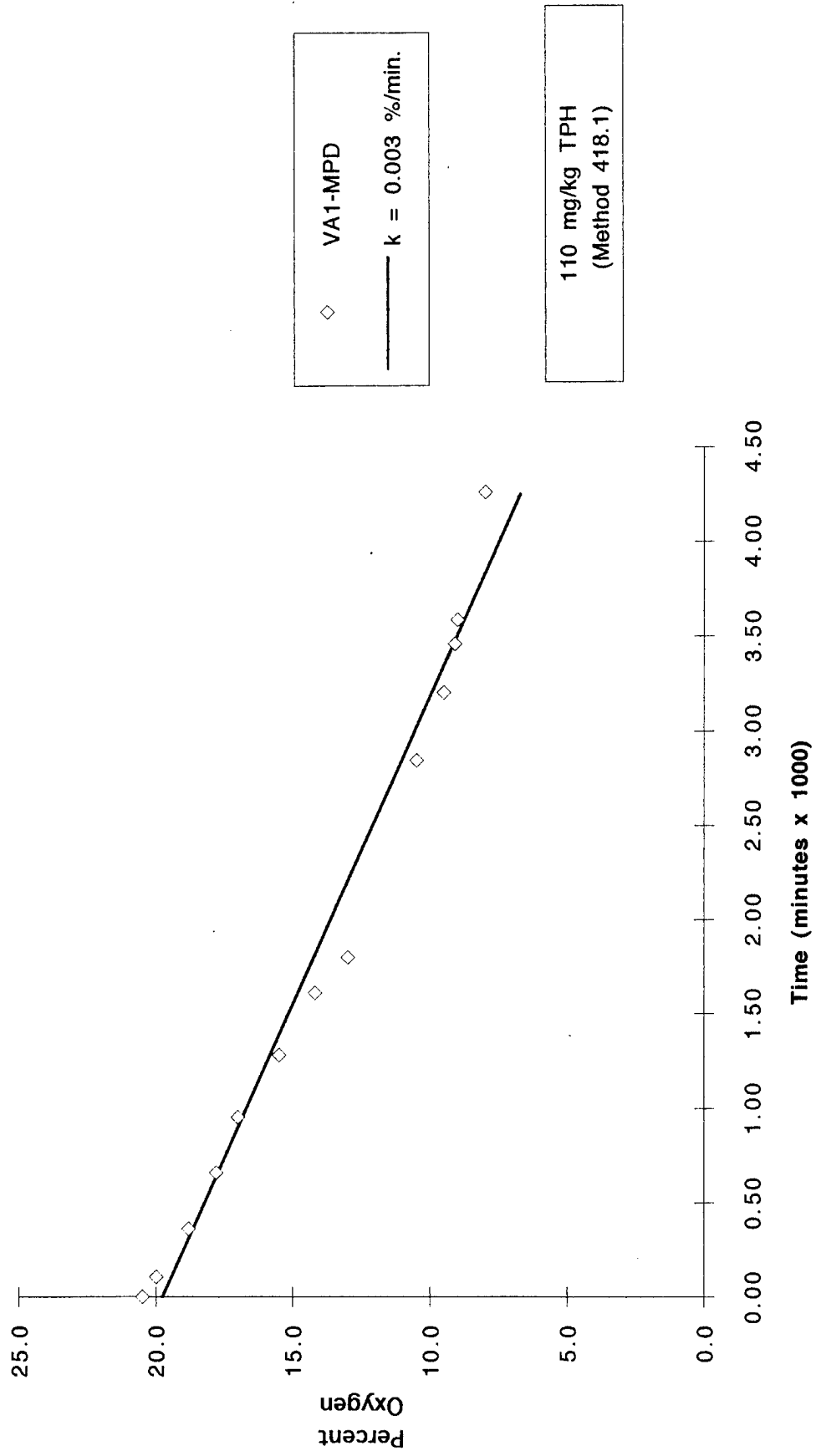

Figure 1.8  
Respiration Test  
Monitoring Point BXS-MW-7  
Vandenberg AFB, CA

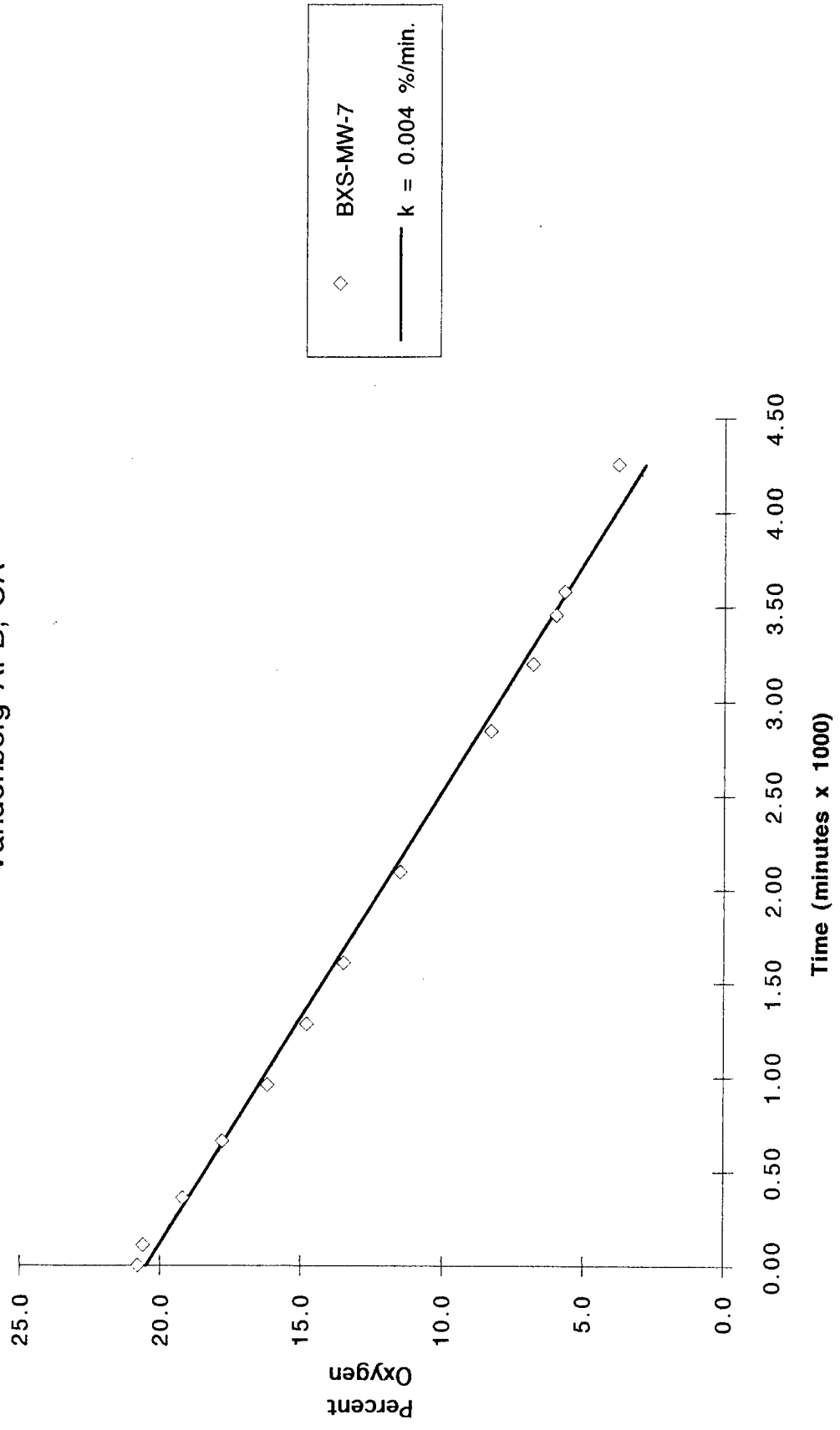
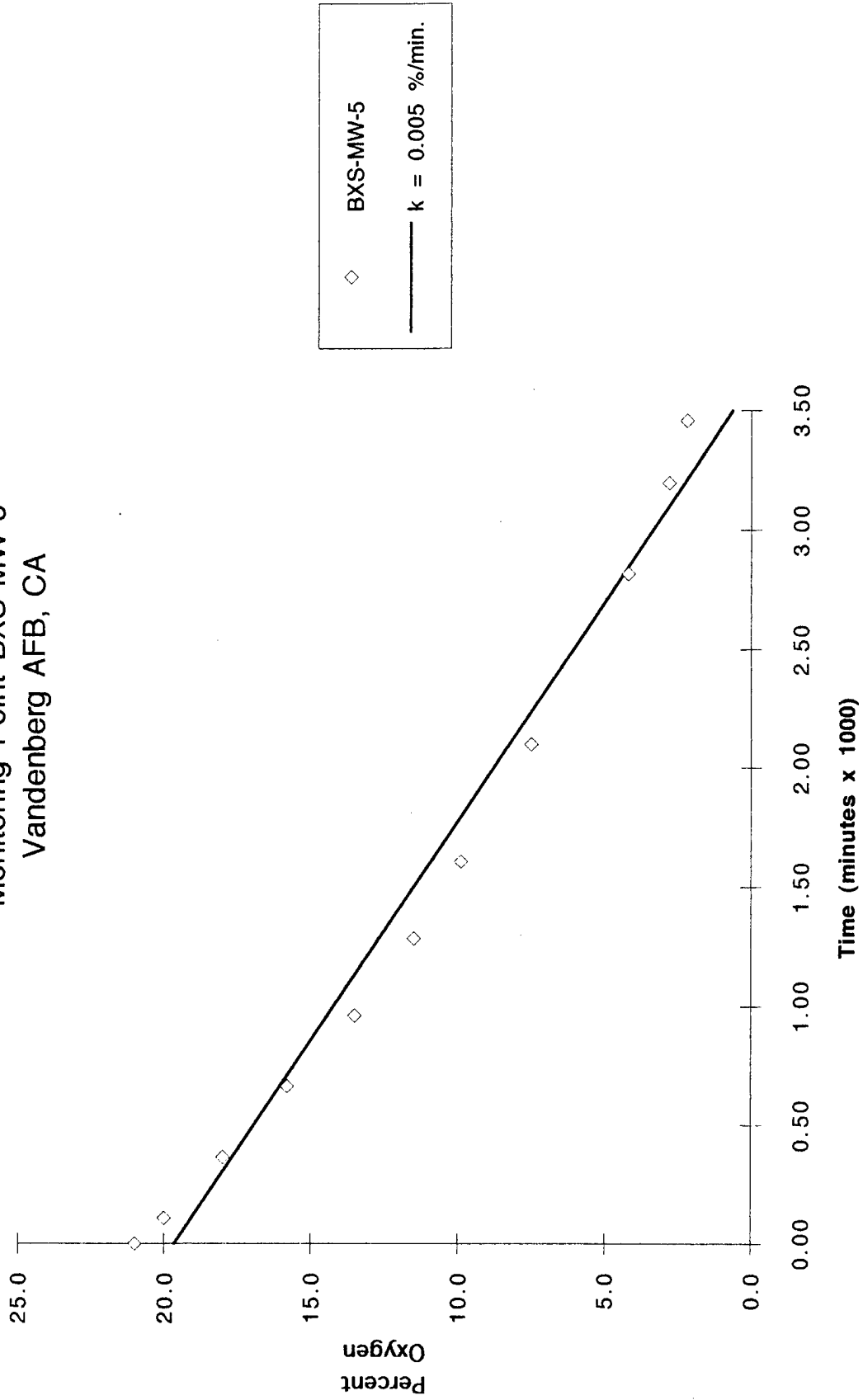

Figure 1.9  
Respiration Test  
Monitoring Point BXS-MW-5  
Vandenberg AFB, CA



### 1.4.5 Potential Air Emissions

As demonstrated during the 17 hour air injection period, the potential for air emissions at the site is high during the initial months of bioventing operations.

To assist in the design specification for the extended bioventing system, a vapor sample was collected from BXS-MW-5. The 1 horsepower blower used during the injection test was repiped and used to extract vapor from BXS-MW-5. The blower operated for 1 hour at a flow rate of approximately 30 scfm (-44 inches H<sub>2</sub>O)). At the end of the 1 hour test, a Tedlar® bag was filled with extracted vapor through a port on the blower's discharge line. The Tedlar® bag was immediately sampled with a SUMMA® canister. Results of the sampling are included in Table 1.5.

**Table 1.5**  
**1 hour Vapor Extraction Test**  
**Sample Analytical Results**

Location	TVH As Jet Fuel (ppmv)	Benzene (ppmv)	Toluene (ppmv)	Total Xylenes (ppmv)	Ethyl benzene (ppmv)
BXS-MW-5	78,000	420	690	220	50

## 2.0 RECOMMENDATIONS FOR EXPANDED PILOT TEST

The proposed system for expanded pilot testing is depicted on the bioventing system installation plan presented in Figure 2.1. The system is designed to operate at a flow rate that is sufficient to provide oxygen to the entire contaminated volume without creating excess volatile emissions at the site. Because of the potential danger of uncontrolled migration of the gasoline vapor, the blower will extract rather than inject air through the contaminated soil zone. Based on the radius of influence measured during the pilot testing, and experience at the Eglin AFB bioventing site, a blower capable of operating at 40 scfm at a vacuum of 40 inches H<sub>2</sub>O will be installed. A 1 horsepower Gast Model R4110N or EG&G Rotron Model DR404 AX5B explosion proof or equivalent will be adequate for this application, and will provide additional capacity for recirculation of vapor-laden air.

This bioventing system has been designed to maximize the recirculation of vapor-laden air through site soils. Figure 2.1 illustrates the recommended conceptual design for this site. Five 4-inch vapor extraction wells (VEWs), including BXS-MW-12, will draw oxygenated air into the site from all directions stimulating aerobic biodegradation. A dilution valve located on the vacuum side of the blower will be used to control flow rates and supply additional oxygen to the recirculation system. To control and reduce volatile organics in the extracted air stream during the initial months of operations, a PURUS® vapor treatment system will be installed on the site. The treated vapor effluent from the PURUS® system will be reinjected in two biofilter trenches along the perimeter of the site. The purpose of these trenches will be to bioremediate the remaining hydrocarbons in the air stream.

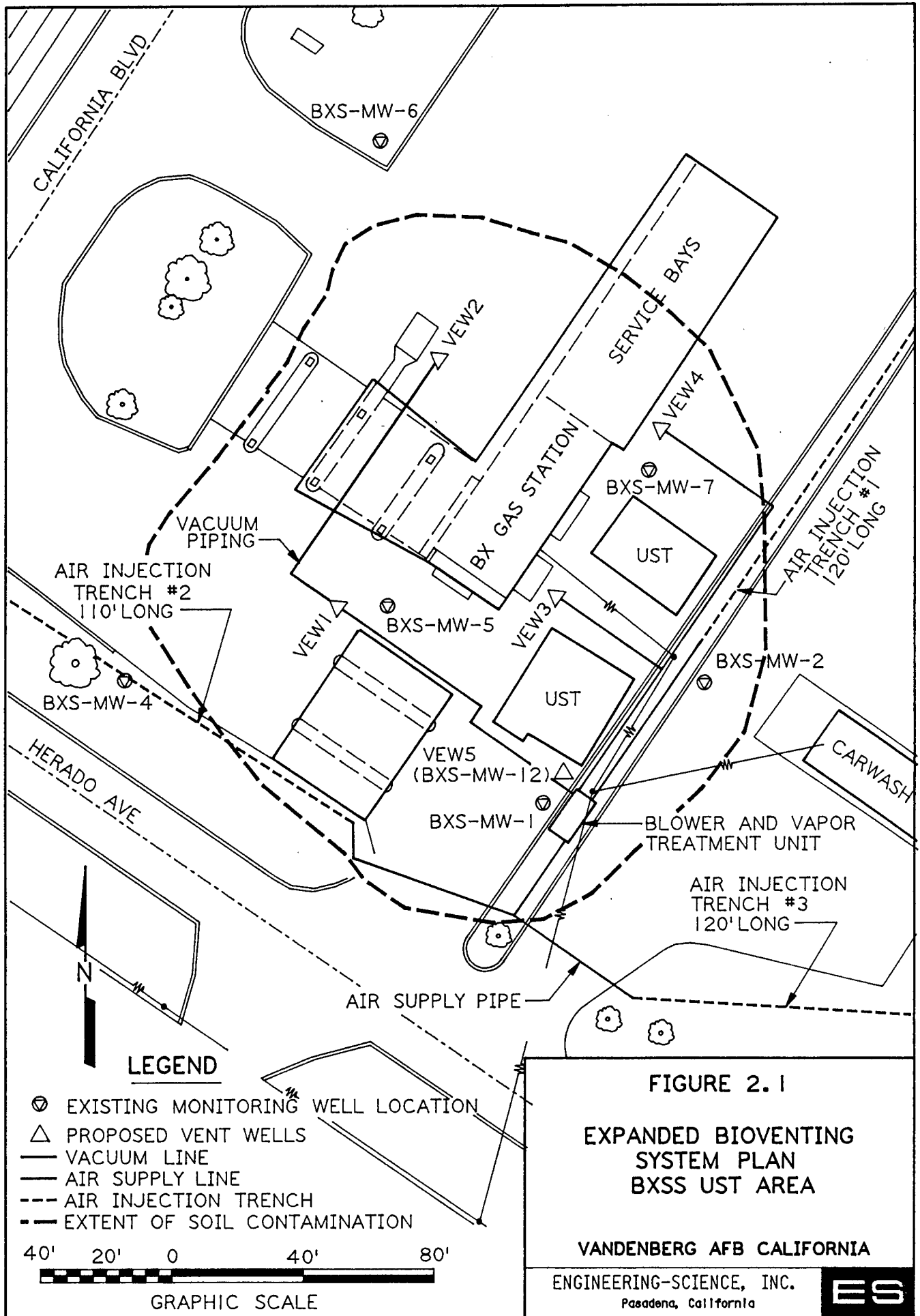

The uptake of oxygen by soil bacteria and subsequent production of carbon dioxide are indicators of biodegradation which can be measured at soil gas monitoring points. To evaluate the effectiveness of this system, existing monitoring points BXS-MW-5, BXS-MW-7, BXS-MW-2 and VA1-MPA, B, C, and D will be used to measure soil gas oxygen concentrations and vacuum influence.

The objectives of this system will be to: 1) supply oxygen to contaminated soils to stimulate *in situ* fuel biodegradation; 2) reduce volatile emissions by treating the extracted soil gas with the PURUS® system before recirculating extracted gases through *in situ* soil; and 3) create a vapor flow gradient away from the existing service station to prevent vapor hazards to building occupants.

## 2.1 Drilling

Drilling work will be conducted to install four new vapor extraction wells. A nominal 6-inch internal diameter, continuous flight hollow stem auger will be used for drilling boreholes for vapor extraction wells.

The boreholes for the vapor extraction wells will be approximately 12 inches in diameter and advanced to a depth of approximately 10 feet. The wells in these boreholes will be installed to a depth of approximately 10 feet (Figure 2.2). The wells will be constructed of 4-inch ID schedule 40 polyvinyl-chloride (PVC) casing and screen. The screen slot size will be 0.040-inch and the screen will be a 5-foot section of PVC. At a maximum the borehole shall extend 12 inches into the water table to accommodate the vapor extraction wells. The purpose for this is to allow bioventing to impact deeper soils as the water table fluctuates seasonally.

Soil samples will be collected for lithologic description as the borings are advanced. These samples will be collected using an 18-inch long split spoon sampler following Standard Penetration Test procedures (ASTM Method D-1586) where applicable. The samples will be collected at 2-foot intervals to depths specified for each type of borehole drilled. Soils will be classified with respect to type, grain size, mineralogy (when pertinent), color, etc. The samples will also be checked for discoloration, odor, and presence of organic vapors. The presence of organic vapors will be tested by placing a portion of the sample in a bottle, sealing the bottle, then testing for the presence of organics in the headspace of the bottle using an organic vapor detector. Information gathered from these sampling efforts will be recorded on the boring log being created for that borehole.

## 2.2 Piping and Air Injection Trench Excavations

The bioventing system will also require three air injection trenches and air supply piping excavations. Locations of the proposed excavations are presented on Figure 2.1. A typical section of pipe and air injection trench is included in the conceptual details for the bioventing systems on Figure 2.3. Installation of trenches for system piping will be in accordance with OSHA regulations.

### 2.2.1 Air Injection Trenches

Air injection trenches will be used to recirculate hydrocarbon vapors for treatment in the soil and to circulate additional oxygen to contaminated soils.

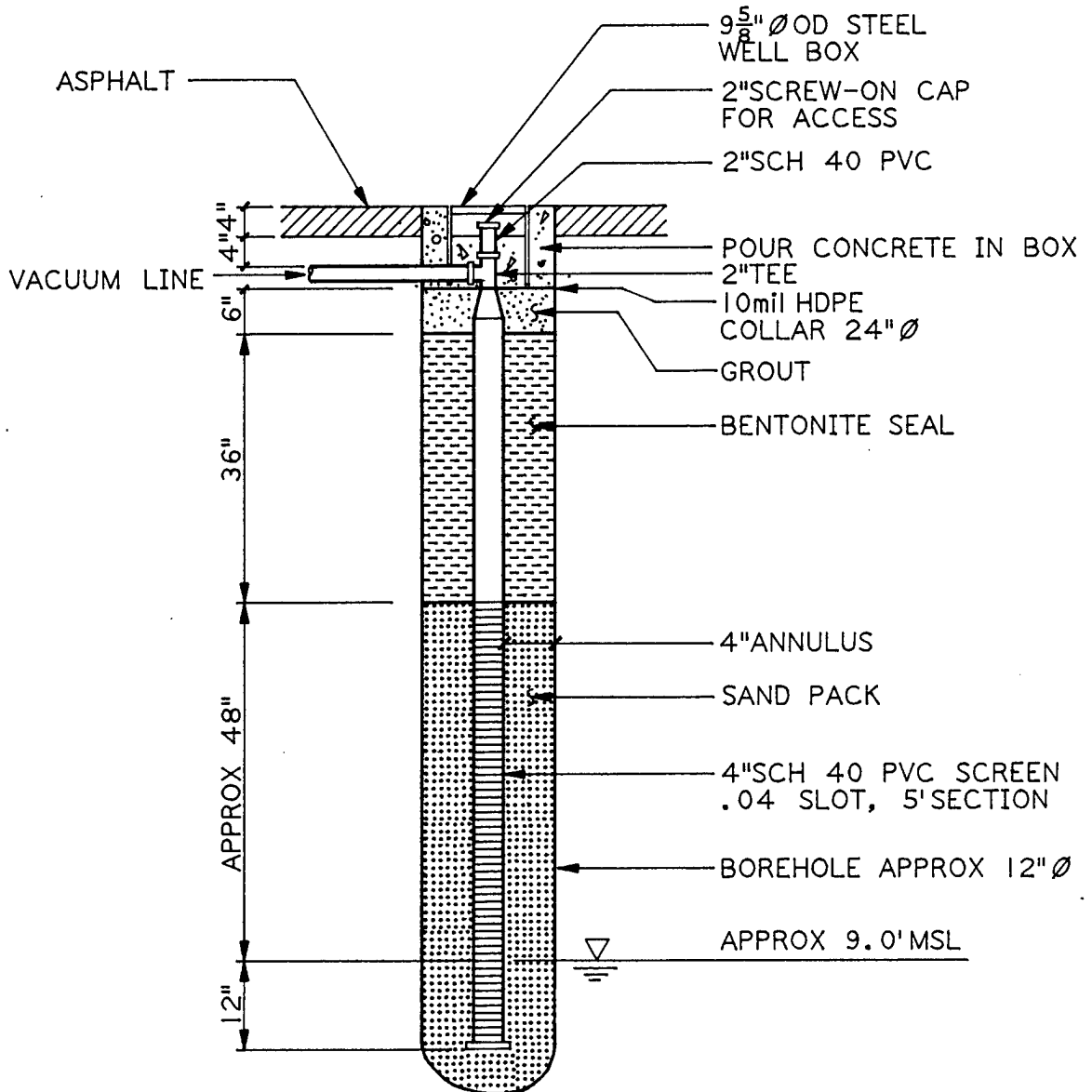

FIGURE 2.2

TYPICAL VAPOR EXTRACTION WELL (VEW)

VANDENBERG AFB CALIFORNIA

ENGINEERING-SCIENCE, INC.  
Pasadena, California

ES

Trenches constructed for installation of the air injection piping will be excavated to a maximum depth of 4 feet and 1 foot in width. The actual bottom of the trench will be determined by the on-site ES engineer based on the stability of the undisturbed material. Sections of the trenches to be constructed are shown on Figure 2.3.

### **2.2.2 Auxiliary Piping Trenches**

Excavations constructed for installation of vacuum line piping will be excavated to a maximum of 18 inches. If foundation soil is soft, wet, unstable or does not afford solid foundation for pipe, the subcontractor will excavate 6 inches below pipe grade and backfill with approved material as specified below.

### **2.2.3 Photographs**

Photographs of the trenching operations will be taken to document test activities. Photographs will be stored in the ES project files and will be provided to AFCEE and Vandenberg AFB.

### **2.2.4 Utilities**

Prior to any excavation activities, the excavation/drilling contractor will meet with a base civil engineering representative and determine the location of all underground utilities in the proposed trenching areas. Utilities will be identified in the field and marked by the base civil engineering personnel. All appropriate digging permits will be obtained from the base before excavation activities are initiated.

## **2.3 Soil Sampling Procedures**

The soil samples collected during hand augering or split- spoon sampling will be screened for contamination visually and with an organic vapor detector. A portion of the sample will be tested for the presence of organic vapors by transferring the soil to a glass bottle immediately upon retrieval, filling the bottle to 3/4 full, capping the bottle with aluminum foil, waiting for approximately 5 minutes, and then inserting the probe of the organic vapor detector through the foil into the headspace. The readings obtained will be recorded on the drilling records. The samples will be examined for obvious signs of contamination including discoloration and odor. Any indications of contamination will be noted on the boring logs. The samples will be labelled and examined visually for lithologic description.

## **2.4 Extraction Well Construction**

### **2.4.1 Well Casing**

All VEWs will be constructed of new, decontaminated, 4-inch ID, Schedule 40, polyvinyl-chloride (PVC) casing and screen (Figure 2.2). However, a reducer will be used to complete the VEWs just below the ground surface as a 2-inch well. The purpose for this is to allow for placement of an adaptor for monitoring equipment and for use in connecting to the vacuum line. A threaded 4-inch PVC bottom cap will be installed at the bottom of the well. Whenever possible, air tight threaded fittings will be used. All PVC casing will be straight and plumb, and will conform to



ASTM Standards F-480-88A or National Sanitation Foundation Standard 14 (Plastic Pipe Section).

The PVC casing will be visually inspected by the on site geologist prior to installation. Any section of PVC pipe that does not appear straight and in good condition will be rejected.

#### **2.4.2 Well Screen**

The VEWs will each have a 5-foot section of PVC screen. Screens will be 4-inch ID for the VEWs and constructed of Schedule 40 PVC factory-slotted screen. Screen slot size will be 0.040-inch for the VEWs. Screen intervals in the VEWs are shown in Figure 2.2.

#### **2.4.3 Filter Pack**

A filter pack will be emplaced in each VEW from the bottom of the borehole to a few inches above the top of the well screen. The filter pack will be tremied into the annular space using a 1.5-inch (minimum) diameter pipe. The tremie pipe will be lifted from the bottom of the hole at the same rate that the filter pack is set. The filter pack material will be clean, well rounded, inert silica sand. Filter pack shall be No. 6-9 silica sand (or equivalent) in the VEWs.

#### **2.4.4 Bentonite Seal**

A 36-inch thick wet bentonite seal will be placed directly above the filter pack in the VEWs. The bentonite will be tremied into the annular space. A minimum of one hour will be allowed for hydration of the bentonite before installation of the grout seal. The bentonite must form a complete seal. The depths at which bentonite seals will be placed in the VEWs are also shown in Figure 2.2.

#### **2.4.5 Grout Seal/Grouting**

A 6-inch grout seal will be emplaced above the bentonite seal in the VEWs, and above the natural pack in the shallow MPs. The grout will be mixed in the following proportions:

- 94 pounds of neat Type I Portland (or API Class A) cement.
- 4 pounds of pure sodium bentonite powder.
- 6.5 gallons of potable water.

Because of the shallow depth of well completion the grout can be poured.

#### **2.4.6 Surface Completion of VEWs and MPs**

Each of the VEWs will be completed flush to the surface using a 9 5/8-inch OD metal box. The fittings that will be installed at the top of the VEWs are also shown in Figure 2.2. These fittings include a 2-inch Schedule 40 ID casing with a screw-on cap for access to each VEW.

## **2.5 Piping Construction**

Air injection pipes and associated piping will be installed as shown in Figures 2.1 and 2.3. All pipe, fittings, couplings, and appurtenant items shall be new, free from defects or contamination, and will be standard products of the manufacturer.

### **2.5.1 Air Injection Piping**

The purpose of the air injection pipes will be to recirculate hydrocarbon vapors and provide oxygen to the contaminated soils at the south and east end of the site. The pipe will be laid in the bottom of the trench at an approximate depth of 4 feet. All injection pipes will be constructed of 2-inch Schedule 40 PVC screen with 0.02 slot. Screen lengths will be furnished in 10-foot flush threaded lengths. The PVC piping will be inspected by the onsite ES representative prior to installation. Any section of PVC pipe that does not appear in good condition will be rejected. All elbows, joints and fittings will be connected using standard PVC cements.

Backfill between the injection screen and the trench will consist of a gravel pack made up of pea size gravel. The gravel pack will be uniform in size and will be introduced uniformly across the screened interval. The gravel pack will extend approximately 4 inches above the top of the screen. A sheet of 10-mil PVC material will be laid on top of the gravel pack and overlain by 6 inches of wet bentonite and natural backfill to the ground surface as shown in Figure 3. Since the air injection piping will be located in low traffic areas the backfill will not be compacted.

### **2.5.2 Vacuum and Injection Line Piping**

Vacuum and injection line piping will be installed at the site as shown in Figure 2.3. All vacuum and injection line piping will be constructed of solid 2-inch Schedule 80 PVC pipe. All elbows, joints and fittings will be threaded and air tight. Vacuum lines will slope toward the VEW to allow condensate to drain into the VEW and away from the blower.

Backfill material for auxiliary pipe trenches will consist of uncontaminated natural soil or equivalent material. In areas of heavy traffic, material will be placed in 6 inch layers and compacted by tamping. Backfilling of the pipe zone will be completed by hand with particular attention to the underside of pipe and pipe fittings. Backfill will be placed to provide a firm support along the full length of the pipe.

## **2.6 Decontamination Procedures**

### **2.6.1 General Decontamination Procedures**

All equipment and tools that will be used at the site will be cleaned as necessary prior to each use. This effort will help prevent possible sample contamination from the variety of sampling equipment, tools and machinery that will be available for use during the execution of the field work. Decontamination will be documented in the field log book.

## **2.6.2 Drilling Equipment**

The drilling rig will be decontaminated by steam cleaning, washing with a non-phosphate laboratory-grade detergent and rinsing with potable water before moving to perform drilling work. All other drilling equipment, including casing and well screens, will be decontaminated following the procedures mentioned below.

## **2.6.3 Sampling Equipment**

All tools used for sampling, including split spoons, will be decontaminated before each use. Decontamination will consist of a laboratory grade detergent wash (e.g., Liquinox®), potable water rinse, pesticide-grade methanol rinse, and high pressure liquid chromatography (HPLC) grade water rinse, followed by air-drying. When dry, the equipment shall be wrapped in aluminum foil until ready for use. In general, as much decontamination as possible will be done at a designated area, preferable a base wash rack. Decontamination fluids will be discharged into the base sewer system. Decontamination fluids resulting from onsite decontamination will be collected and transported to the designated area for disposal.

Decontamination will be conducted in a manner that will guard against cross-contamination of equipment. Equipment will be placed on clean plastic sheeting or on surfaces covered with aluminum foil. Personnel will wear clean vinyl gloves during decontamination of equipment.

All decontamination procedures performed during the course of the field work will be documented in the field logbook. Any deviation from these decontamination procedures will be noted.

## **2.7 Asphalt/Pavement Patching**

This section includes the material and construction requirements necessary to repair any asphalt or pavement changed by construction of the bioventing system. Any asphalt or pavement to be removed will be saw cut along straight lines to provide a vertical surface abutting asphalt or pavement to remain.

### **2.7.1 Materials**

The aggregate used for the base will match existing material. The aggregate will consist of clean, hard durable fragments or particles of stone crushed to conform to that of aggregate commonly used at Vandenberg AFB in an area subject to loading by semi-tractor trailers and other heavy vehicles. Base material will be approved in advance by the ES representative.

The asphalt mix used to replace the excavated surface material will match the existing material. The mix will conform to mixes commonly used in the area for surfaces designed for fully loaded semi-tractor trailers. Mix shall be approved in advance by the ES representative.

### **2.7.2 Aggregate and Asphalt Placement**

Prior to placement of aggregate, the surface of the subgrade will be compacted to provide a firm surface. The aggregate will be placed in layers of not more than 2 inches (compacted) in thickness to match existing conditions. Aggregate will be

placed directly on the prepared subgrade or on the preceding layer of compacted aggregate by approved methods. Immediately after material has been placed, it will be compacted with a vibratory compactor of adequate size and then approved by the ES representative prior to any additional covering.

The asphalt mix shall be placed in layers or lifts of not more than 2 inches (compacted) in thickness to match existing conditions. Asphalt shall be placed directly on the prepared base or on the preceding layer of compacted asphalt by approved methods. Immediately after material has been placed, it shall be compacted with a vibratory compactor of adequate size and then approved by the onsite ES representative prior to any additional covering. The edges of the repaired section shall meet the existing pavement in flush, vertical joints to prevent mixing of new and old asphalt.

## **2.8 Extraction Equipment**

The vapor extraction (VE) unit to be used for the bioventing test is depicted in a flow diagram included in the site conceptual details provided on Figure 2.3. The unit consists of a vacuum blower, starter, air filter, flow control and air bleed valves, pressure and temperature gauges, flow indicator, and air sampling points. The following section describes the equipment and processes.

Based on a similar bioventing system at Eglin AFB, a continuous extraction rate of 8-10 scfm per well should produce a single well radius of oxygen influence of approximately 40 ft beneath the asphalt surface. Radius of influence, minimum oxygen supply requirements, and the area of contaminated soil were used for the total system design.

### **2.8.1 Vacuum Blower**

To create a vacuum in the subsurface, a vacuum blower will be used to remove air from the VEWs. A blower capable of providing 40 scfm at approximately 40 inches of water-column vacuum is required. A Gast Model R4110N or EG&G Rotron Model DR404 AR72M or equivalent has been selected as the vacuum blower to be used on site. The blower is constructed of aluminum for explosion proof operation.

The blower is driven by an explosion-proof 1 horsepower electric motor. It is rated for continuous-duty service, full-voltage starting, and is suitable for outdoor locations. A 230-volt, three-phase, 100 amp, 60-cycle electrical power source will be required at the site. This may be provided from the power pole near vent VA1-MPD. An explosion-proof starter will be installed through which power from the source to the blower will be controlled.

### **2.8.2 Instrumentation**

Piping connecting each VEW to the blower will consist of 2-inch-inside-diameter, Schedule-80 PVC pipe and fittings. As mentioned before, a 2-inch PVC header will be used to manifold the air flow from each VEW. Air velocity ports will be placed on each vapor extraction well vacuum line to measure air flow from each VEW. Air velocity ports will also be located on each air injection pipeline to measure injection

flow rates. A vacuum indicator and a temperature indicator will be located in 1.5-inch-diameter galvanized inlet pipe (V1 and T1 shown on Figure 2.3). A dilution valve will also be installed in the 1.5-inch galvanized pipe to regulate the vacuum and flow rate.

A water knock-out pot may be required if significant moisture condenses in the air filter unit. A knock-out pot will not be placed on the unit initially because it requires frequent maintenance. However, the blower configuration will allow the installation of a knock-out if required.

A particulate filter will be placed in-line between the VEWs and the blower to protect the blower. A vacuum indicator will be installed after the filter to measure the pressure differential across the filter (V2 shown on Figure 3). A vacuum relief valve will also be provided between the filter and blower. If the filter becomes fouled, the vacuum relief valve will prevent damage to the piping and blower. A pressure indicator (0-100 inches H<sub>2</sub>O) and temperature indicators will be installed between the blower outlet and the discharge piping (P3 and T2 shown on Figure 3). The discharge piping will consist of steel and PVC piping.

Vapor-sampling points will be placed between VEWs and the blower and in the air injection piping (S shown on Figure 2.3).

### **2.8.3 Vapor Treatment Unit**

Based on the results from a similar bioventing system on Eglin AFB, Florida, the initial volatile organic concentrations (VOCs) in extracted soil gas could exceed 50,000 ppmv. Within two weeks, an order of magnitude decrease in these concentrations was observed at the Eglin AFB site. A PURUS® Model 150 vapor treatment system will be used to reduce the volatile organics in the extracted soil gas prior to reinjection into the biofilter trenches. The PURUS® system will be used to reduce initial VOC concentrations to approximately 1,000 ppmv. At this concentration, soil biodegradation rates are expected to exceed the rate of hydrocarbon vapor loading into the biofilter trenches.

The PURUS® unit uses an adsorbent filter bed and desorbition/condensor system to reclaim petroleum hydrocarbons from the vapor phase and return them to a liquid phase for reuse or disposal. A three month rental of the PURUS® system is anticipated.

## **2.9 Regulatory Requirements and Permitting**

All drilling, well installation, sampling, trenching, and other construction activities pursuant to installation of the bioventing system shall be conducted in accordance with applicable laws, rules and regulations. The base will be contacted for construction requirements to enable issuance of permits where applicable. Well installation permits will be obtained from the state by the drilling subcontractor. Vandenberg AFB officials will be responsible for coordinating and obtaining any additional permits for air emissions or for the extended pilot test. ES will assist the base by providing technical input.

## 2.10 Summary

Initial bioventing tests on this site indicate that oxygen has been depleted in highly contaminated soils and that air injection is an effective method of increasing aerobic fuel biodegradation. An expanded pilot test has been recommended.

Based on the results of the first year of bioventing, AFCEE will recommend one of three options:

1. Upgrade and continue operation of the bioventing system for remediation of the site. If additional removal of free product or groundwater treatment is required, AFCEE can assist in the design and construction of an integrated remediation system.
2. If final soil sampling indicates significant contaminant removal has occurred, AFCEE may recommend additional sampling to confirm that cleanup criteria have been achieved.
3. If significant difficulties or poor results are encountered during bioventing at this site, AFCEE could recommend the removal of the blower system and proper abandonment of the VWs.

## 2.11 Cost Estimate

The estimated cost of installing the expanded pilot system and three months of rental charge for the PURUS® vapor treatment system is estimated at \$82,000.

<u>Item</u>	<u>Cost</u>
Additional Drilling	\$10,000
Excavation/Piping	\$25,000
Blower Unit/Electrical	\$3,000
PURUS® Unit Setup	\$6,000
PURUS® Unit Rental (3 months)	\$15,000
ES Construction Management	<u>\$23,000</u>
TOTAL	\$82,000

## 2.12 Schedule

The following schedule is recommended for the extended pilot test construction and operation.

<u>Event</u>	<u>Schedule</u>
Pilot Test Results Provided to AFCEE/Vandenberg AFB	11 November 1992
AFCEE/Vandenberg Review Complete	25 November 1992
Regulatory Review Complete	11 December 1992
Permitting, Subcontracting Complete	13 January 1993
Construct Pilot System	20 January 1993
Begin Operations	03 February 1993
Respiration Test	July 1993
Final Respiration Test/Soil Sampling	February 1994

### 3.0 REFERENCES

Site Assessment Report for Base Exchange Service Station, Site Characterization (Volume I). U.S. Bureau of Land Reclamation, March 1992.

Field Sampling Plan for AFCEE Bioventing. Engineering-Science, Inc., 1992.

Test Plan and Technical Protocol for a Field Treatability Test for Bioventing. Hinchee, R.E., Ong, S.K., Miller, R.N., Downey, D.C., Frandt, R., January 1992.