

LOAN DOCUMENT

PHOTOGRAPH THIS SHEET

①

DTIC ACCESSION NUMBER

LEVEL

INVENTORY

Initial Remedial Action Plan for ...

DOCUMENT IDENTIFICATION

Oct 96

DISTRIBUTION STATEMENT A
Approved for Public Release
Distribution Unlimited

DISTRIBUTION STATEMENT

ACCESSION FOR	
NTIS	GRAM <input type="checkbox"/>
DTIC	TRAC <input type="checkbox"/>
UNANNOUNCED	<input type="checkbox"/>
JUSTIFICATION	
BY	
DISTRIBUTION/	
AVAILABILITY CODES	
DISTRIBUTION	AVAILABILITY AND/OR SPECIAL
A-1	

DISTRIBUTION STAMP

DATE ACCESSIONED

DATE ACCESSIONED

DATE RETURNED

DATE RETURNED

REGISTERED OR CERTIFIED NUMBER

REGISTERED OR CERTIFIED NUMBER

20001208 004

DATE RECEIVED IN DTIC

PHOTOGRAPH THIS SHEET AND RETURN TO DTIC-FDAC

H
A
N
D
L
E

W
I
T
H

C
A
R
E

**Initial Remedial Action Plan for an
Expanded Bioventing System
Facilities 44625D and 44625E**



**Cape Canaveral Air Station
Florida**

Prepared For

**Air Force Center for Environmental Excellence
Brooks Air Force Base
San Antonio, Texas**

and

**45 CES/CEV
Patrick Air Force Base,
Florida**

October 1996



1700 Broadway, Suite 900 • Denver, Colorado 80290

AQ mol-03-0483

**Initial Remedial Action Plan for an
Expanded Bioventing System
Facilities 44625D and 44625E**



**Cape Canaveral Air Station
Florida**

Prepared For

**Air Force Center for Environmental Excellence
Brooks Air Force Base
San Antonio, Texas**

and

**45 CES/CEV
Patrick Air Force Base,
Florida**

October 1996



**PARSONS
ENGINEERING SCIENCE, INC.**

1700 Broadway, Suite 900 • Denver, Colorado 80290

AQ mol-03-0483

DEFENSE TECHNICAL INFORMATION CENTER REQUEST FOR SCIENTIFIC AND TECHNICAL REPORTS

Title AFCEE Collection

1. Report Availability (Please check one box)	2a. Number of Copies Forwarded	2b. Forwarding Date
<input checked="" type="checkbox"/> This report is available. Complete sections 2a - 2f. <input type="checkbox"/> This report is not available. Complete section 3.	<u>1 each</u>	<u>July/2000</u>

2c. Distribution Statement (Please check ONE box)

DoD Directive 5230.24, "Distribution Statements on Technical Documents," 18 Mar 87, contains seven distribution statements, as described briefly below. Technical documents MUST be assigned a distribution statement.

DISTRIBUTION STATEMENT A: Approved for public release. Distribution is unlimited.

DISTRIBUTION STATEMENT B: Distribution authorized to U.S. Government Agencies only.

DISTRIBUTION STATEMENT C: Distribution authorized to U.S. Government Agencies and their contractors.

DISTRIBUTION STATEMENT D: Distribution authorized to U.S. Department of Defense (DoD) and U.S DoD contractors only.

DISTRIBUTION STATEMENT E: Distribution authorized to U.S. Department of Defense (DoD) components only.

DISTRIBUTION STATEMENT F: Further dissemination only as directed by the controlling DoD office indicated below or by higher authority.

DISTRIBUTION STATEMENT X: Distribution authorized to U.S. Government agencies and private individuals or enterprises eligible to obtain export-controlled technical data in accordance with DoD Directive 5230.25, Withholding of Unclassified Technical Data from Public Disclosure, 6 Nov 84.

2d. Reason For the Above Distribution Statement (in accordance with DoD Directive 5230.24)

2e. Controlling Office	2f. Date of Distribution Statement Determination
<u>HQ AFCEE</u>	<u>15 Nov 2000</u>

3. This report is NOT forwarded for the following reasons. (Please check appropriate box)

It was previously forwarded to DTIC on (date) and the AD number is

It will be published at a later date. Enter approximate date if known.

In accordance with the provisions of DoD Directive 3200.12, the requested document is not supplied because:
.....
.....

Print or Type Name	Signature
<u>Laura Peña</u>	<u>Laura Peña</u>
Telephone	(For DTIC Use Only) AQ Number
<u>210-536-1431</u>	<u>NOI-03-0483</u>

**INITIAL REMEDIAL ACTION PLAN
FOR AN EXPANDED BIOVENTING SYSTEM
AT FACILITIES 44625D AND 44625E
CAPE CANAVERAL AIR STATION, FLORIDA**

Prepared for

**Air Force Center For Environmental Excellence
Brooks Air Force Base, Texas**

And

45 CES/CEV

Patrick Air Force Base, Florida

October 1996

Prepared by:

**Parsons Engineering Science, Inc.
1700 Broadway, Suite 900
Denver, Colorado 80290**

CONTENTS

	<u>Page</u>
P.E. CERTIFICATION	iii
SECTION 1 - INTRODUCTION	1-1
SECTION 2 - SITE BACKGROUND	2-1
2.1 Site History	2-1
2.2 Site Geology and Hydrogeology	2-3
2.3 Site Contaminants	2-3
SECTION 3 - BIOVENTING PILOT TESTING RESULTS	3-1
3.1 Pilot-Scale System Configuration	3-1
3.2 Initial Soil Gas Chemistry	3-3
3.3 <i>In Situ</i> Biodegradation Rates	3-5
3.4 Oxygen Influence/Air Permeability	3-5
3.5 Soil and Soil Gas Sampling Results	3-7
3.6 Potential Air Emissions	3-10
3.7 Recommendation for Full-Scale Bioventing	3-10
SECTION 4 - EXPANDED BIOVENTING SYSTEM	4-1
4.1 Objectives	4-1
4.2 Basis of Design	4-1
4.3 System Design	4-3
4.4 Project Schedule	4-6
4.5 System Operation, Maintenance, and Monitoring	4-6
4.5.1 System Optimization and Operation	4-6
4.5.2 System Maintenance	4-7
4.5.3 System Performance Monitoring	4-7
SECTION 5 - HANDLING OF INVESTIGATION-DERIVED WASTES	5-1
SECTION 6 - BASE AND STATION SUPPORT REQUIREMENTS	6-1
SECTION 7 - POINTS OF CONTACT	7-1
SECTION 8 - REFERENCES	8-1

APPENDIX A: DESIGN PACKAGE

APPENDIX B: DESIGN CALCULATIONS

TABLES

	<u>Page</u>
3.1 Pilot Scale VW and MP Construction Data	3-2
3.2 Initial Soil Gas Conditions	3-4
3.3 Respiration and Degradation Rates	3-6
3.4 Facility 44625D - Soil and Soil Gas Analytical Results	3-8
3.5 Facility 44625E - Soil and Soil Gas Analytical Results	3-9

FIGURES

	<u>Page</u>
2.1 Site Layout and Geologic Cross-Section Locations	2-2
2.2 Hydrogeologic Cross-Section A-A'	2-4
2.3 Hydrogeologic Cross-Section B-B'	2-5
2.4 Phase I Sampling Locations	2-7
2.5 Phase II and Bioventing Pilot Test Sampling Locations	2-8
2.6 Supplemental Assessment Soil Sampling Locations	2-10
2.7 Supplemental Assessment Groundwater Sampling Locations	2-11
2.8 One-Year Bioventing Soil and Soil Gas Sampling Locations and Results	2-13
4.1 Proposed Full-Scale Bioventing System Configuration	4-4
4.2 Contingency Full-Scale Bioventing System Configuration	4-5

P.E. CERTIFICATION

The initial remedial action plan for the Generator Shop Maintenance Facility (Facilities 44625D and E) located at Cape Canaveral Air Station (AS), Florida has been reviewed. The Florida Department of Environmental Protection (FDEP) facility ID number for this site is 05/8622713.

I hereby certify that, in my professional judgment, the components of this initial remedial action plan satisfy the requirements set forth in Chapter 62-770, Florida Administrative Code (FAC). This plan is intended to address soil contamination only. Groundwater remediation is not specifically addressed in this plan. The engineering design features incorporated in this plan provide reasonable assurances of achieving the soil remediation objectives stated in Chapter 62-770, FAC. To the best of my knowledge, this plan is free of errors and omissions and follows the guidelines outlined in the Petroleum Contamination Site Cleanup Criteria for Initial Remedial Actions-Alternative Procedures.

Signature Douglas C Downey, P.E.

FL 31941

P.E. Registration

10/14/96

Date

SECTION 1

INTRODUCTION

This initial remedial action plan (RAP) presents the scope for an expansion of pilot-scale bioventing systems in the vicinity of Facilities 44625D and 44625E at Cape Canaveral Air Station (AS), Florida. The purpose of the expanded bioventing system will be to better achieve full-scale *in situ* remediation of unsaturated fuel-contaminated soils at the site. The activities related to the installation of the proposed expanded system will be performed by Parsons Engineering Science, Inc. (Parsons ES) for the Air Force Center for Environmental Excellence (AFCEE) Technology Transfer Division (ERT) under contract F41624-92-D-8036, 0017. The AS is administered from nearby Patrick Air Force Base (AFB) where the point of contact for this project is based. The primary objectives of the bioventing system upgrade are to:

- Deliver oxygen to contaminated vadose zone soils throughout the affected portions of the site;
- Provide additional characterization data for site closure;
- Continue aerobic *in situ* remediation of fuel-contaminated soils by injection of atmospheric air into soil; and
- Sustain aerobic *in situ* biodegradation until hydrocarbon-contaminated soils within the unsaturated zone are remediated to levels below State of Florida regulatory standards.

Extended bioventing pilot tests were performed at Facilities 44625D and 44625E from October 1994 through December 1995 to determine if *in situ* bioventing is a feasible cleanup technology for fuel-contaminated soils within the unsaturated zone. A radius of oxygen influence of approximately 30 feet was observed around each of the individual vertical air injection wells installed at the facilities. Additional details on the pilot test procedures and results are presented in the *Draft Interim Pilot Test Results Report for Facilities 1748, 44625D, and 44625E, Cape Canaveral AFS, Florida* (Engineering-Science, Inc. [ES], 1994).

At the conclusion of the extended pilot tests, soil gas and soil samples were collected and analyzed to quantify contaminant removal over the course of the pilot test. Soil gas data confirmed significant vapor-phase contaminant removal in the pilot test areas. Reductions in total recoverable petroleum hydrocarbon (TRPH) soil concentrations were noted at some locations, but remained unchanged at other locations. The extended pilot tests demonstrated that significant oxygen utilization and biodegradation are continuing at the pilot test locations, and that continued bioventing will sustain the

biodegradation of remaining fuel residuals. Further discussion of the pilot test results is presented in Section 3. Pilot test results for the two facilities supported the recommendation of an expanded (full-scale) bioventing system to cost effectively remediate the remaining fuel-hydrocarbon-contaminated soils at Facilities 44625D and 44625E.

This RAP addresses unsaturated soil contamination associated with petroleum releases in the vicinity of Facilities 44625D and 44625E. Site investigation data collected to date indicate that the majority of soil contamination in the vicinity of Facilities 44625D and 44625E is "smear zone" contamination. Smear zone contamination results when dissolved or free-phase petroleum hydrocarbons sorb to soils near the groundwater surface. Smearing occurs as a result of fluctuations in the groundwater surface elevation. It appears that a release of waste oil from the former underground storage tank (UST) near Facility 44625D has resulted in significant smear zone contamination in soils within the immediate area of the release, as well as downgradient from the former UST location. Site investigation data also suggest that numerous past surface spills and leaks of petroleum products have occurred at these facilities (CH₂M Hill, 1992). The proposed expansion of the bioventing system will provide oxygen to all contaminated soils to facilitate the natural biodegradation of petroleum hydrocarbons.

Pilot test data from this site and system optimization data from horizontal air injection vent well (VW) bioventing systems installed at the BX Service Station and at Fire Training Area 2 (FTA-2) at Patrick AFB have been used to design the expanded bioventing system. The expanded system will consist of newly constructed air injection vent wells (VWs) and vapor monitoring points (MPs). Two horizontal VWs will be installed to more efficiently deliver oxygen throughout the entire area of unsaturated, smear zone, fuel-contaminated soils. The existing vertical VWs installed during initial pilot testing will not be used in the expanded system. Four new MPs will be constructed to monitor changes in soil gas chemistry that are indicative of fuel contaminant reduction and oxygen influence. It is anticipated that natural fluctuations in the water table elevation will periodically expose the contaminated smear zone (during periods of low groundwater levels) to the influence of air injection. Therefore, over time, all contaminated soils should be remediated.

This document is divided into eight sections including this introduction, and two appendices. Section 2 discusses site background and includes a review of existing characterization data. Section 3 provides the results of the extended pilot tests conducted at Facilities 44625D and 44625E. Section 4 identifies the target treatment area of the proposed expanded system; provides construction details of the expanded system; and recommends a proven, cost-effective approach for the remediation of the hydrocarbon-contaminated soils at the site. Procedures for handling investigation-derived waste are described in Section 5, and Base and Station support requirements are listed in Section 6. Section 7 lists the key points of contact for Patrick AFB, AFCEE, and Parsons ES. Section 8 provides the references cited in this document. A design package for the expanded bioventing system is provided in Appendix A and design calculations are provided in Appendix B.

SECTION 2

SITE BACKGROUND

2.1 SITE HISTORY

Cape Canaveral AS lies on the eastern coast of Florida between the Banana River and the Atlantic Ocean. The installation is approximately 10.5 miles long and varies in width from approximately 1 mile at its narrowest points to 4.6 miles at its widest points. Launch facilities for the US Air Force (USAF) and National Aeronautics and Space Administration (NASA) lie on the northeastern edge of the facility adjacent to the Atlantic Ocean. Support, research, and administrative complexes occupy the west-central and southern portions of the facility. Facilities 44624D and 44625E are located near the center of Cape Canaveral AFS within the industrial portion of the station. The AS is administered from nearby Patrick Air Force Base (AFB), where the point of contact for this project is based.

A layout of Facilities 44625D and 44625E, also known as the Generator Maintenance Facility, is provided in Figure 2.1. A 1,000-gallon UST was installed north of and adjacent to Facility 44625D in 1965 and used to store waste oil collected in an oil/water separator located within Facility 44625D (ES, 1994). The waste oil tank was removed in October 1991, and replaced with an aboveground storage tank (AST) (CH₂M Hill, 1994). According to AS personnel, during the excavation a layer of stained soil was apparent along the northeastern side of the open excavation. Approximately 200 cubic yards of petroleum-contaminated soil were excavated and disposed of offsite, and approximately 4,000 gallons of waste oil and groundwater were pumped from the excavation during removal of the waste oil UST (CH₂M Hill, 1994). AS personnel also reported that the ground surface in the vicinity of the former waste oil UST numerous surface spills and leaks of petroleum products in the past (CH₂M Hill, 1994).

CH₂M Hill (1994) conducted Phase I and Phase II assessments at Facilities 44625D and 44625E. In January 1992, CH₂M Hill conducted the Phase I assessment and discovered hydrocarbon contamination in soils in the vicinity of the waste oil UST. During this investigation, elevated volatile hydrocarbon concentrations also were noted during headspace analysis of soil samples obtained from the unsaturated zone at less than 6 feet below ground surface (bgs) on the northeastern side of Facility 44625E. Groundwater sampling performed during the Phase I investigation indicated the presence of benzene, toluene, ethylbenzene, and xylenes (BTEX) and polynuclear aromatic hydrocarbon (PAH) compounds in groundwater at concentrations above the Florida Department of Environmental Protection (FDEP) regulatory criteria (CH₂M Hill, 1994).

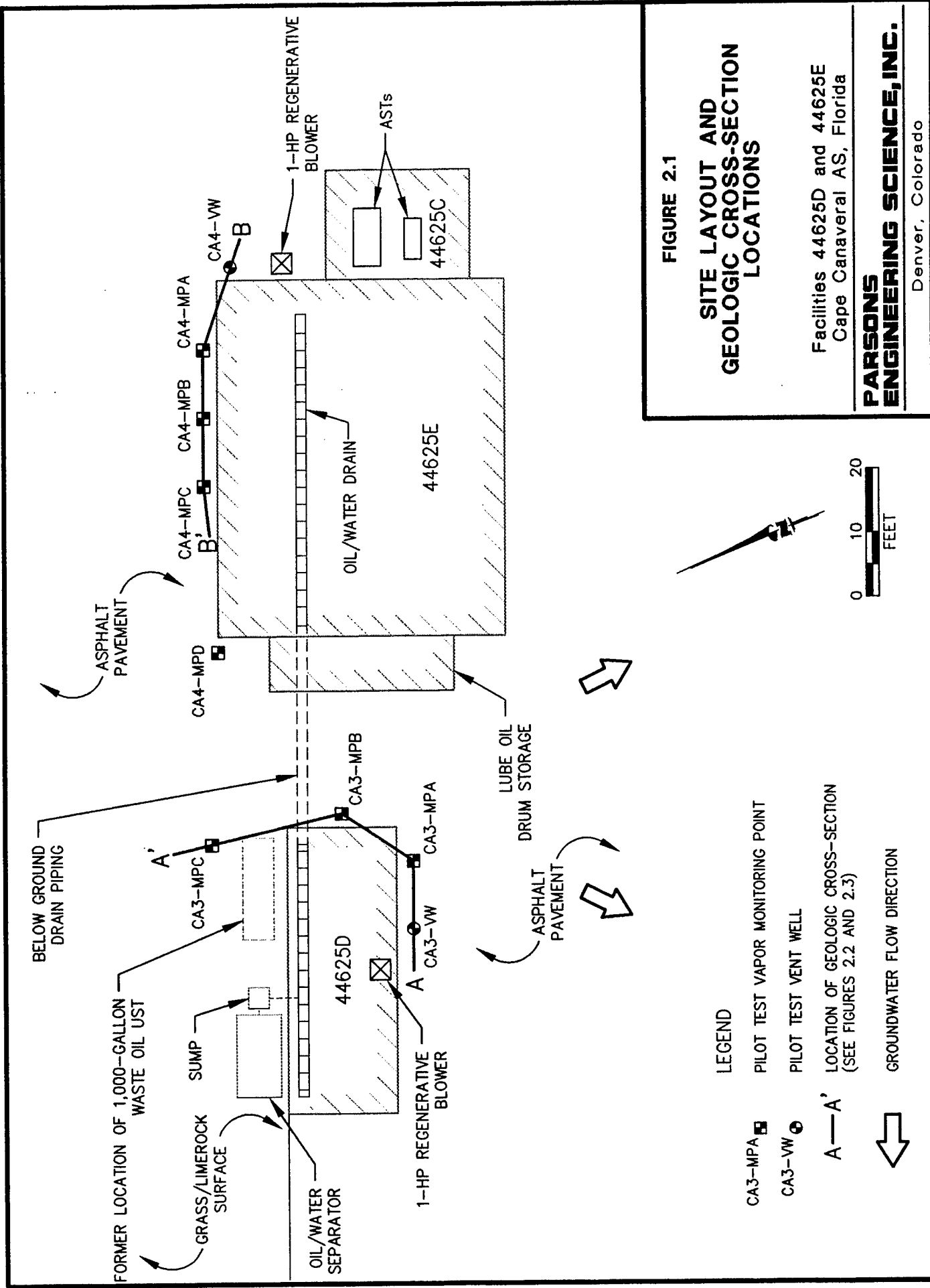

FIGURE 2.1

**SITE LAYOUT AND
GEOLOGIC CROSS-SECTION
LOCATIONS**

Facilities 44625D and 44625E
Cape Canaveral AS, Florida

**PARSONS
ENGINEERING SCIENCE, INC.**
Denver, Colorado

LEGEND

- CA3-MPA PILOT TEST VAPOR MONITORING POINT
- CA3-VW PILOT TEST WELL
- A—A' LOCATION OF GEOLOGIC CROSS-SECTION
(SEE FIGURES 2.2 AND 2.3)
- GROUNDWATER FLOW DIRECTION

The Phase II investigation was performed during 1992, 1993, and 1994. Sampling during these investigations was designed to better delineate the areas of soil contamination and to assess the extent of groundwater contamination. At the conclusion of the Phase II investigation, long-term monitoring of groundwater at the site was recommended (CH₂M Hill, 1994). Additional sampling was performed at the site in April 1995 to address the comments of the FDEP on the Phase II assessment.

Concurrent with the Phase II investigation, ES installed bioventing pilot test systems at Facility 44625D and 44625E as part of the AFCEE Bioventing Initiative program (ES, 1994). The pilot test systems (Figure 2.1) were operated for 1 year beginning in October 1994, after which soil and soil gas sampling and *in situ* respiration testing were performed. Based on the results of the 1-year test, which are presented in Section 3 of this RAP, expansion of the pilot test systems to a full-scale system was funded under the AFCEE Extended Bioventing program.

In support of the full-scale system design, soil gas data were collected at the facilities in June 1996 to quantify the extent of contaminated unsaturated soils at the site. Soil gas samples were collected and screened in the field for oxygen (O₂), carbon dioxide (CO₂), and total volatile hydrocarbons (TVH). The results of this sampling event were used to determine the extent of soils that would benefit from oxygenation via the full-scale bioventing system. Further details on this soil gas sampling event are presented in Section 2.3 of this RAP.

2.2 SITE GEOLOGY AND HYDROGEOLOGY

Because the bioventing technology is applied to unsaturated soils, this section primarily addresses soils above the shallow aquifer. A more detailed discussion of site geology and hydrogeology can be found in the *Draft Interim Pilot Test Results Report for Facilities 1748, 44625D, and 44625E, Cape Canaveral Air Force Station, Florida* (ES, 1994).

Unsaturated soils at Facilities 44625D and 44625E consist of predominantly unconsolidated, moderately well-sorted, fine- to coarse-grained quartz sand with up to 40 percent shells and shell fragments. The sites are capped with asphalt paving and lime rock. The shallow groundwater beneath the site is in an unconfined aquifer and is typically encountered at depths between 6 and 8 feet bgs; however, the groundwater surface may be encountered at depths as shallow as 3 feet bgs during periods of heavy rainfall.

Figures 2.2 and 2.3 are geologic cross-sections (traced on Figure 2.1) of the pilot test sites at Facilities 44625D and 44625E that were constructed using the geologic logs of the bioventing pilot test VWs and MPs. The interpreted soil profiles are shown along with TVH field screening results, VW and MP screened intervals, and total recoverable petroleum hydrocarbon (TRPH) concentrations from laboratory analysis of soil samples (ES, 1994).

2.3 SITE CONTAMINANTS

As part of the Phase I Assessment at the site in January 1992, subsurface soil samples were collected using a hand auger. Soil samples were collected from 14

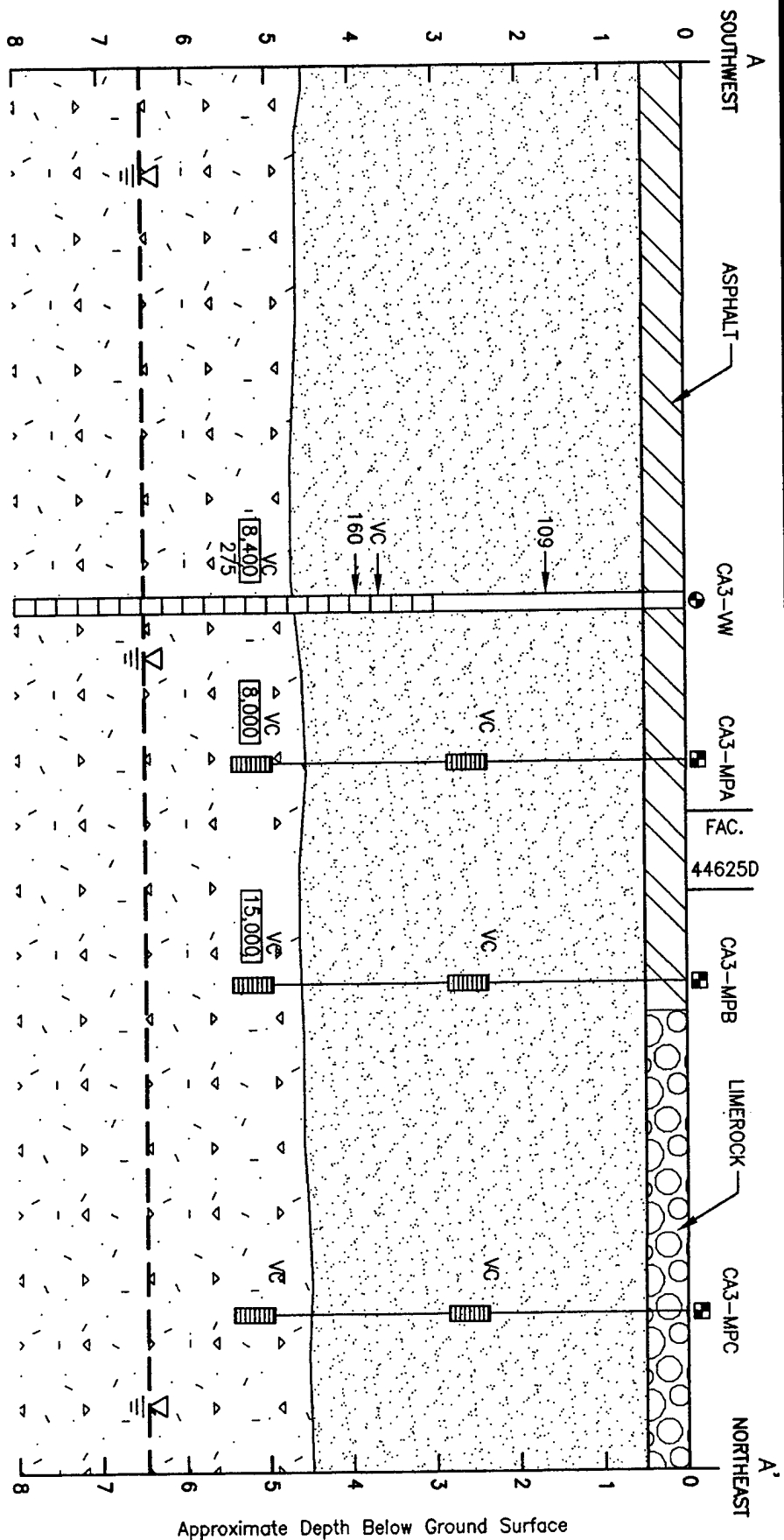

FIGURE 2.2
HYDROGEOLOGIC
CROSS-SECTION A-A'

Facilities 44625D and 44625E
Cape Canaveral AS, Florida

PARSONS
ENGINEERING SCIENCE, INC.

Denver, Colorado

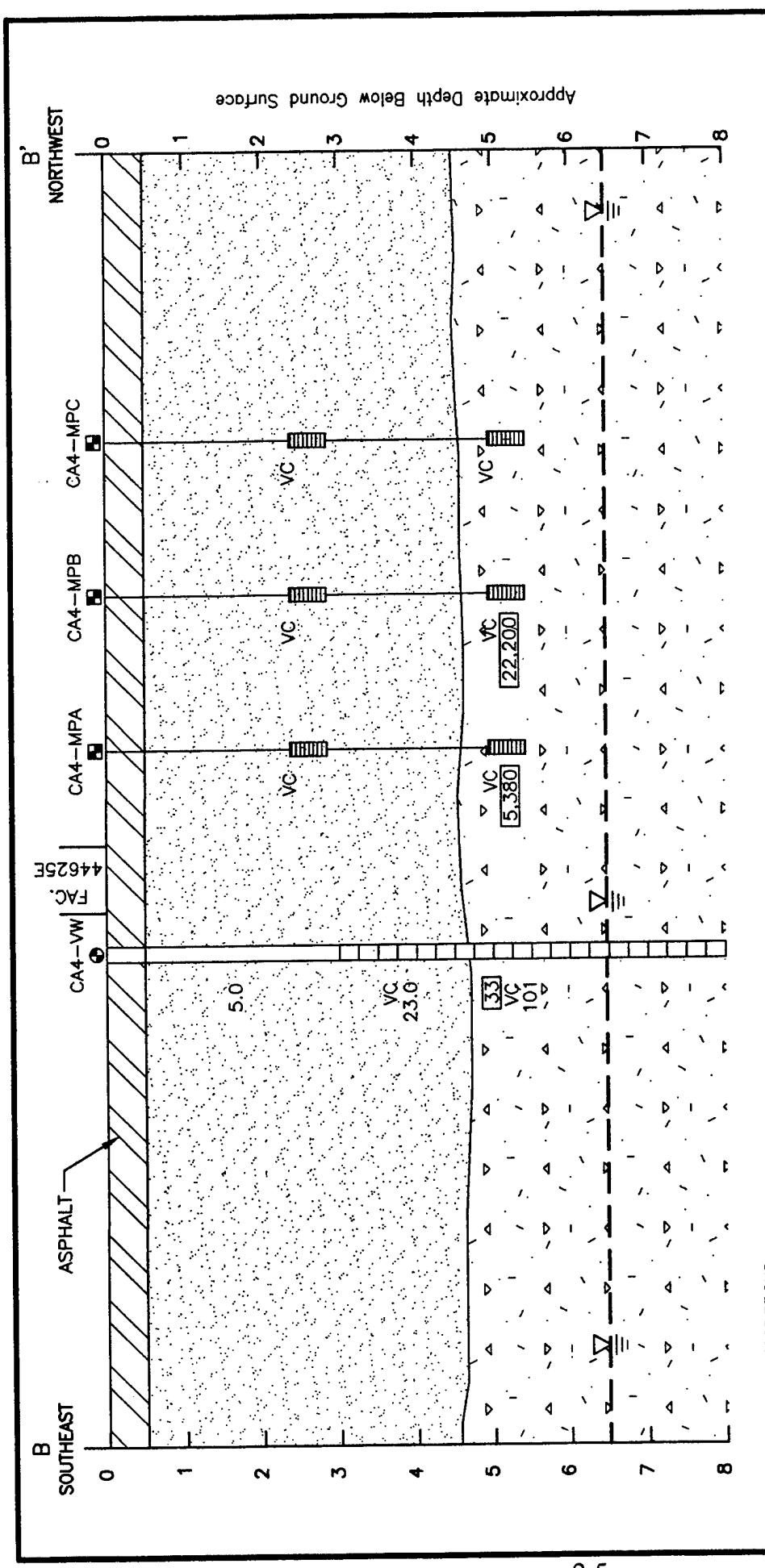

FIGURE 2.3

**HYDROGEOLOGIC
CROSS-SECTION B-B'**

Facilities 44625D and 44625E
Cape Canaveral AS, Florida

**PARSONS
ENGINEERING SCIENCE, INC.**

Denver, Colorado

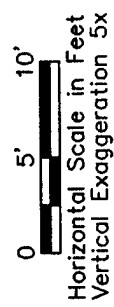

LITHOLOGIC DESCRIPTIONS

Fine-Coarse Sand,
w/Shell Fragments

FINE TO MEDIUM SAND

LEGEND

- Permanent monitoring point screened interval
- Vent Well Screened Interval
- Permanent Monitoring Point
- Permanent Injection Vent Well
- Water table surface
- Visible contamination (soil staining) VC
- Lab results for soil total petroleum hydrocarbons (mg/kg) 5.380
- Field screening results for soil gas total volatile hydrocarbons (ppmv) 101

Note: Water table depth shown was estimated on 12/23/93 during vent well construction.

borings (B-1 through B-14) at 2-foot intervals from the ground surface to approximately 6 feet bgs, where groundwater was encountered. The samples were screened in the field using an organic vapor analyzer (OVA) with a flame ionization detector (FID) and the headspace analysis method described in Chapter 17-770.200(2), Florida Administrative Code (FAC). Petroleum odor and staining were noticeable in some of the samples collected. Two of the 14 borings installed at the site, B-5 and B-14, had elevated soil headspace concentrations of petroleum hydrocarbon vapors. Phase I sampling locations are shown on Figure 2.4.

Four temporary groundwater monitoring wells (TMW-1 through TMW-4) were installed in hand-augured boreholes during the Phase I investigation. Three wells were placed near the suspected source of contamination, and one was placed downgradient to assess contaminant migration. Groundwater samples extracted from the wells were analyzed for aromatic volatile organic compounds (VOCs) by US Environmental Protection Agency (USEPA) analytical Method 602 and for PAHs by USEPA Method 610. Total BTEX was detected in the sample from TMW-1 at a concentration of 337 micrograms per liter ($\mu\text{g/L}$). This sample was the only one that exhibited contaminant concentrations that exceeded the FDEP target cleanup level of 50 $\mu\text{g/L}$ for BTEX. Three of the four wells (TMW-1, TMW-2, and TMW-3) contained total PAH concentrations in excess of the target cleanup level of 100 $\mu\text{g/L}$. These exceedances of the BTEX and PAH regulatory cleanup criteria prompted a Phase II assessment of the sites (CH₂M Hill, 1994).

As part of the Phase II investigation at the two facilities, 13 soil borings and 8 permanent groundwater monitoring wells were installed at the site. All soil borings were advanced to approximately 5.5 feet bgs with a hand auger. Soil samples were collected from 10 borings (B15 through B24) for headspace analysis following the same methods used during the Phase I investigation. Three borings (S1 through S3) were installed with a hand auger for the collection of samples for laboratory analysis. Seven of the groundwater monitoring wells (MW1 through MW7) were screened from 2 to 12 feet bgs. One deep well, DW1, was installed at the site to quantify deeper groundwater contamination. The deep well was screened from 25 to 35 feet bgs. Phase II sampling locations are presented in Figure 2.5.

Boring B15 contained unsaturated soils that were contaminated, based on headspace readings. This was the only boring of the 10 sampled for headspace analysis that demonstrated contaminated soils. Six samples were collected from three borings in May 1994 for laboratory analysis. Samples were collected from 2 and 5 feet bgs in each boring and analyzed for arsenic by USEPA Method SW7060, cadmium and chromium by USEPA Method SW6010, lead by USEPA Method SW7421, and TRPH by USEPA Method 418.1. One sample was collected from the most contaminated interval (the 5-foot-bgs interval of S1) and analyzed for priority pollutant volatile/extractable organics by USEPA Methods SW8240/SW8270; for toxicity characteristic leaching procedure (TLCP) extraction by USEPA Method 1310; for arsenic, barium, cadmium, chromium, lead, selenium, and silver by USEPA Method SW6010; and for mercury by USEPA Method SW7470. Total metals and TCLP metals concentrations were below method detection limits in all samples. TRPH were detected in two samples from the 5-foot-bgs intervals of S1 and S3 above the state cleanup criterion (Chapter 17-775, FAC) of 50 milligrams per kilogram (mg/kg). Chlorobenzene and total PAHs were detected in the 5-foot-bgs interval at S1 at

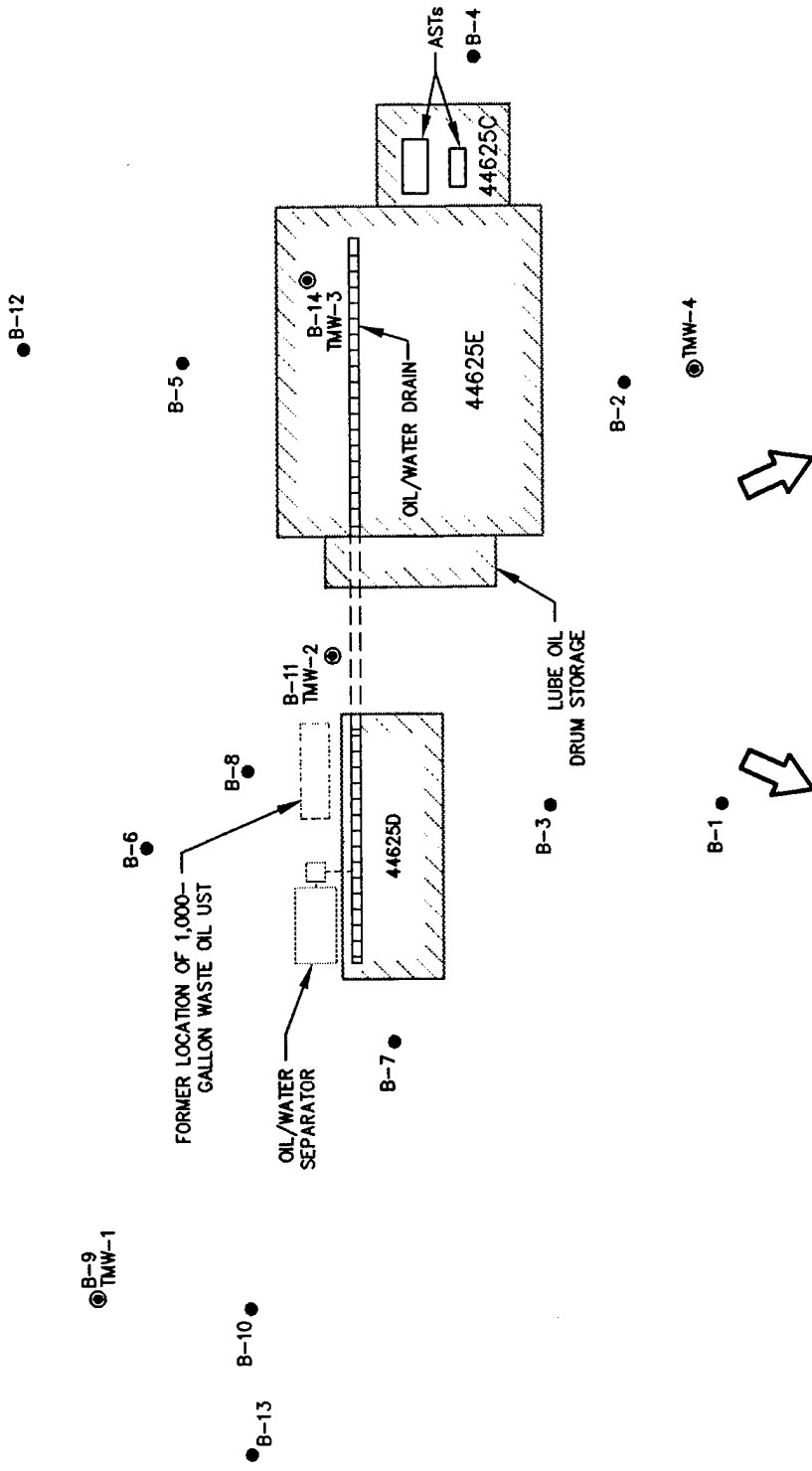

FIGURE 2.4

**PHASE I
SAMPLING LOCATIONS**

Facilities 44625D and 44625E
Cape Canaveral AS, Florida

**PARSONS
ENGINEERING SCIENCE, INC.**

Denver, Colorado

LEGEND

- B-13 ● PHASE I SOIL BORING
- TMW-1 ⊙ PHASE I TEMPORARY MONITORING WELL
- ⇨ GROUNDWATER FLOW DIRECTION

Source: CH₂M Hill, 1994.

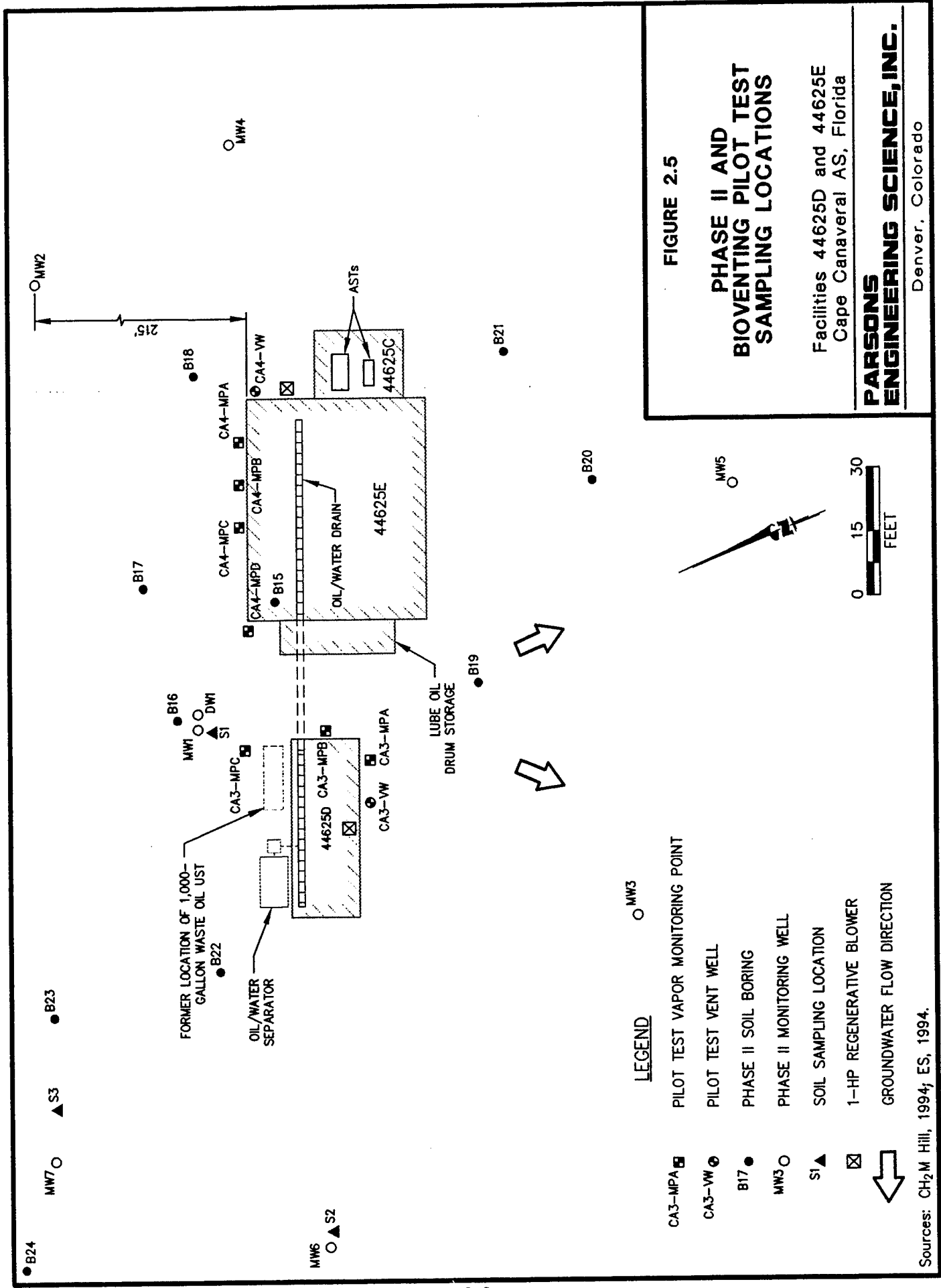

FIGURE 2.5

PHASE II AND BIOVENTING PILOT TEST SAMPLING LOCATIONS

Facilities 44625D and 44625E
Cape Canaveral AS, Florida

PARSONS ENGINEERING SCIENCE, INC.
Denver, Colorado

- LEGEND**
- CA3-MPA [] PILOT TEST VAPOR MONITORING POINT
 - CA3-VW [] PILOT TEST VENT WELL
 - B17 ● PHASE II SOIL BORING
 - MW3 ○ PHASE II MONITORING WELL
 - SI ▲ SOIL SAMPLING LOCATION
 - [] 1-HP REGENERATIVE BLOWER
 - [] GROUNDWATER FLOW DIRECTION

Sources: CH₂M Hill, 1994; ES, 1994.

concentrations that exceed State criteria for total VOCs and total PAHs of 100 micrograms per kilogram ($\mu\text{g}/\text{kg}$) and 1,000 $\mu\text{g}/\text{kg}$, respectively.

The eight Phase II groundwater monitoring wells were sampled in October 1992. The samples were analyzed for volatile halocarbons/aromatics by USEPA Method 601/602, for priority pollutant volatile/extractable organics by USEPA Methods 624/625, for PAHs by USEPA Method 610, for TRPH by USEPA Method 418.1, for arsenic by USEPA Method 206.2, for cadmium by USEPA Method 213.2, for chromium by USEPA Method 218.2, and for lead by USEPA Method 239.2. TRPH were detected in MW1 and MW7 at levels above the Chapter 17-770, FAC, no-further-action criterion of 5 milligrams per liter (mg/L). However, the concentrations of TRPH in these two wells were below the monitoring-only FDEP criterion of 100 mg/L . No contaminants were detected in deep well DW1 at the site (CH₂M Hill, 1994).

A supplemental soil assessment was performed at the site in April 1995 to further delineate the nature and extent of petroleum hydrocarbon contamination at the site. Twenty-seven additional soil borings were installed at the site. Borings SB-1 through SB-27 were installed by hand auger to 5 feet bgs. Headspace samples were collected at 1-foot intervals from each of the borings and screened with an OVA meter. These supplemental soil sampling locations are presented on Figure 2.6. Five of the 27 borings, SB-9, SB-10, SB-15, SB-25, and SB-26, contained soils that were contaminated with petroleum hydrocarbons. One soil sample was collected from 4 feet bgs in the most contaminated boring, SB-15, for laboratory analysis. The sample was analyzed using the same methods previously described for the Phase II assessment. Analyte concentrations from this sample were below 1995 FDEP soil cleanup goals (CH₂M Hill, 1995).

Five of the groundwater monitoring wells installed during the Phase II investigation at the site were destroyed during construction activities at the site in 1994. As part of the supplemental assessment at Facilities 44625D and 44625E, three new groundwater monitoring wells were installed. Monitoring wells MW-8, MW-9, and MW-10 were installed to complement three wells previously installed at the site by ES in November 1993 (MWS08, MWS09, and MWD06) (Figure 2.5). The locations of the groundwater monitoring wells sampled during the supplemental assessment are presented on Figure 2.7 with the exception of MWS08, which is located approximately 200 feet north of Facility 44625D. The three wells installed by ES were sampled in November 1993, and samples were analyzed by USEPA Methods 601, 610, and 418.1. The three new wells installed by CH₂M Hill were sampled in April 1995 and samples analyzed by USEPA Methods 624/625 and 418.1. None of the samples collected during either of these two sampling events contained contaminants at concentrations in excess of FDEP's (1990) monitoring-only groundwater criteria (CH₂M Hill, 1995).

The supplemental assessment concluded that no free product is present at the site and that groundwater contamination at the site is minimal. It was recommended that a monitoring-only plan (MOP) be implemented for groundwater at the site until bioventing has remediated source area soils (CH₂M Hill, 1995).

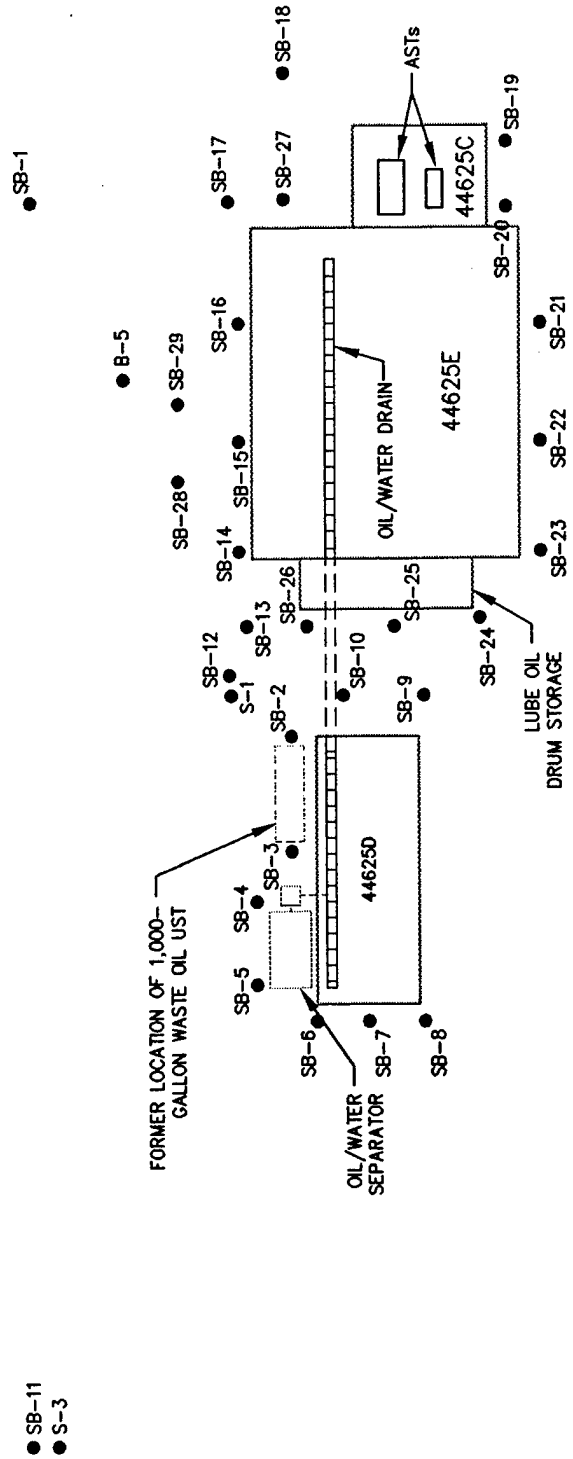
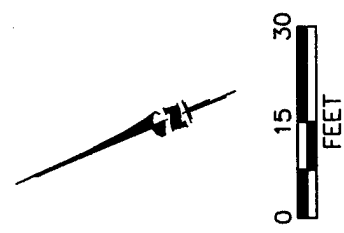

FIGURE 2.6

**SUPPLEMENTAL ASSESSMENT
SOIL SAMPLING
LOCATIONS**

Facilities 44625D and 44625E
Cape Canaveral AS, Florida

**PARSONS
ENGINEERING SCIENCE, INC.**
Denver, Colorado



LEGEND

SB-1 ● SOIL BORING

Source: CH₂M Hill, 1995.

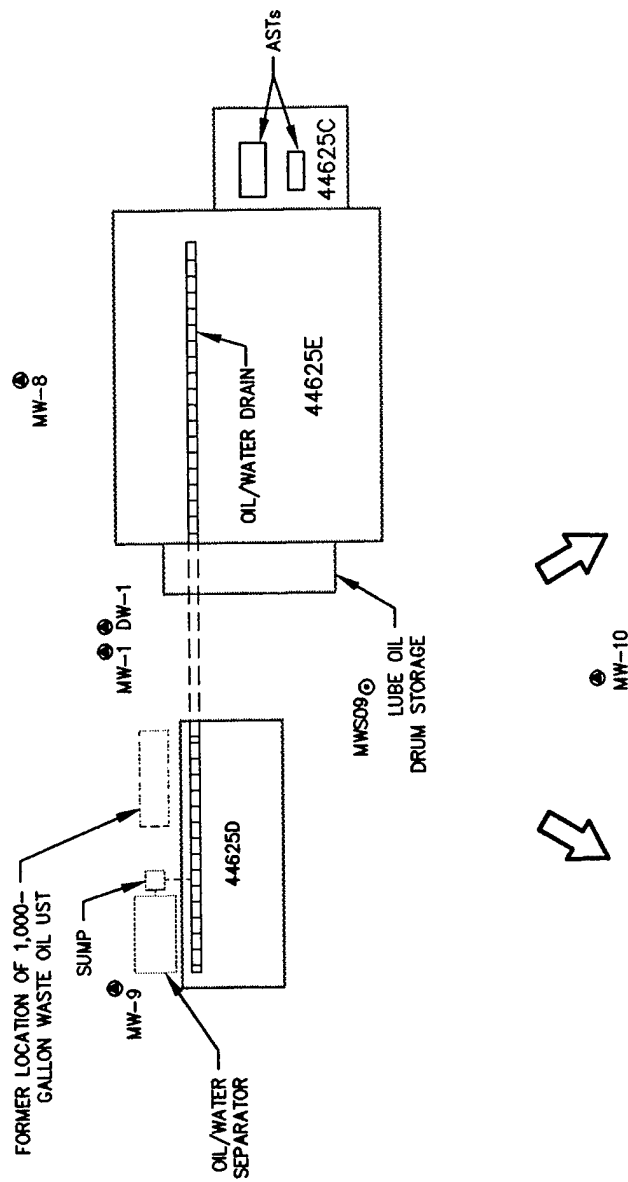

© MWD06

FIGURE 2.7

**SUPPLEMENTAL ASSESSMENT
GROUNDWATER SAMPLING
LOCATIONS**

Facilities 44625D and 44625E
Cape Canaveral AS, Florida

**PARSONS
ENGINEERING SCIENCE, INC.**

Denver, Colorado

LEGEND

- MW-1 ● CH₂M HILL MONITORING WELL
- MWD06 ● PARSONS ENGINEERING SCIENCE MONITORING WELL
- GROUNDWATER FLOW DIRECTION

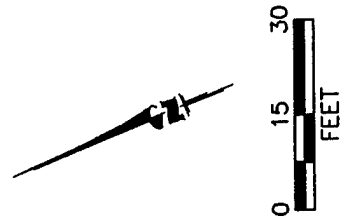

Source: CH₂M Hill, 1995.

K: \AFCEE\726876\CAPE\96DN0622, 08/21/96 at 13:52

Additional soil samples were collected at the site as part of the bioventing pilot tests at Facility 44625D and Facility 44625E. A total of six soil samples were collected during the installation of the system in 1994, three at each pilot test location. Soil samples were also collected at the end of 1 year of bioventing. These final samples were collected in December 1995 from approximately 5.5 feet bgs in hand-augered boreholes. The 1995 soil sample results indicated that TRPH concentrations in soils at the site were still elevated above state action levels. One-year bioventing pilot test soil sampling locations and results are presented on Figure 2.8.

In preparation for design of a full-scale bioventing system for Facilities 44625D and 44625E, a soil gas survey was performed at the site in June 1996. Parsons ES sampled 36 locations for O₂, CO₂, and TVH using probes pushed 2 to 5.5 feet bgs and field screening instruments. The sampling locations included all seven of the bioventing MPs installed as part of the pilot scale tests at the facility. The June 1996 soil gas sampling locations and results are shown on Figure 2.8. The majority of the samples had elevated levels of TVH and depleted O₂ concentrations. The results of this survey indicated that full-scale bioventing at the site would be a cost-effective method to supply the delineated zone of oxygen-depleted soils (Figure 2.8) with atmospheric air and continue to promote the aerobic biodegradation of petroleum hydrocarbons. Furthermore, installation of a full-scale bioventing system will meet the recommendations for soil remediation that were based on the results of the Phase II assessment and supplemental assessment prepared for the site (CH₂M Hill, 1994 and 1995).

SOIL GAS SAMPLING RESULTS FROM
PARSONS ENGINEERING SCIENCE - JUNE 3, 1996
INVESTIGATION AT FACILITIES 44625D AND E
CAPE CANAVERAL AFS, FLORIDA

LOCATION	DEPTH (ft)	O ₂ (%)	CO ₂ (%)	TVH (ppmv) ^{b/}
SG1	3	0.0	12.2	600
SG2	3	12.5	5.3	152
SG3	3	3.5	11.3	340
SG4	3	6.5	7.5	180
SG5	3	7.0	9.2	380
SG6	3	16.0	4.8	180
SG7	3	3.0	8.5	340
SG8	3	16.5	3.3	124
SG9	3	4.0	14.0	340
SG10	2	15.5	3.0	380
SG11	3	0.0	19.5	1,600
SG12	3	0.0	16.0	600
SG13	3	13.5	4.3	200
SG14	3	13.6	6.2	340
SG15	3	5.2	12.0	460
SG16	3	15.0	5.2	200
SG17	3	9.0	6.2	400
SG18	3	8.2	10.0	400
SG19	3	6.0	10.0	440
SG20	3	15.2	3.3	192
SG21	3	5.5	10.0	440
SG22	3	6.2	9.2	400
CA3-MPA	3	0.0	13.5	760
CA3-MPA	5.5	NS ^{c/}	NS	NS
CA3-MPB	3	0.0	16.5	920
CA3-MPB	5.5	NS	NS	NS
CA3-MPC	3	13.5	5.3	136
CA3-MPC	5.5	NS	NS	NS
CA4-MPA	3	0.0	15.5	12,800
CA4-MPA	5.5	NS	NS	NS
CA4-MPB	3	0.0	17.2	>20,000
CA4-MPB	5.5	NS	NS	NS
CA4-MPC	3	0.0	22.0	>20,000
CA4-MPC	5.5	NS	NS	NS
CA4-MPD	3	8.0	8.8	168
CA4-MPD	5.5	NS	NS	NS

a/ DEPTH IN FEET BELOW GROUND SURFACE

b/ TVH = TOTAL VOLATILE HYDROCARBONS; ppmv= PARTS PER MILLION, VOLUME PER VOLUME

c/ NS = NOT SAMPLED; SCREENED INTERVAL WAS UNDER WATER

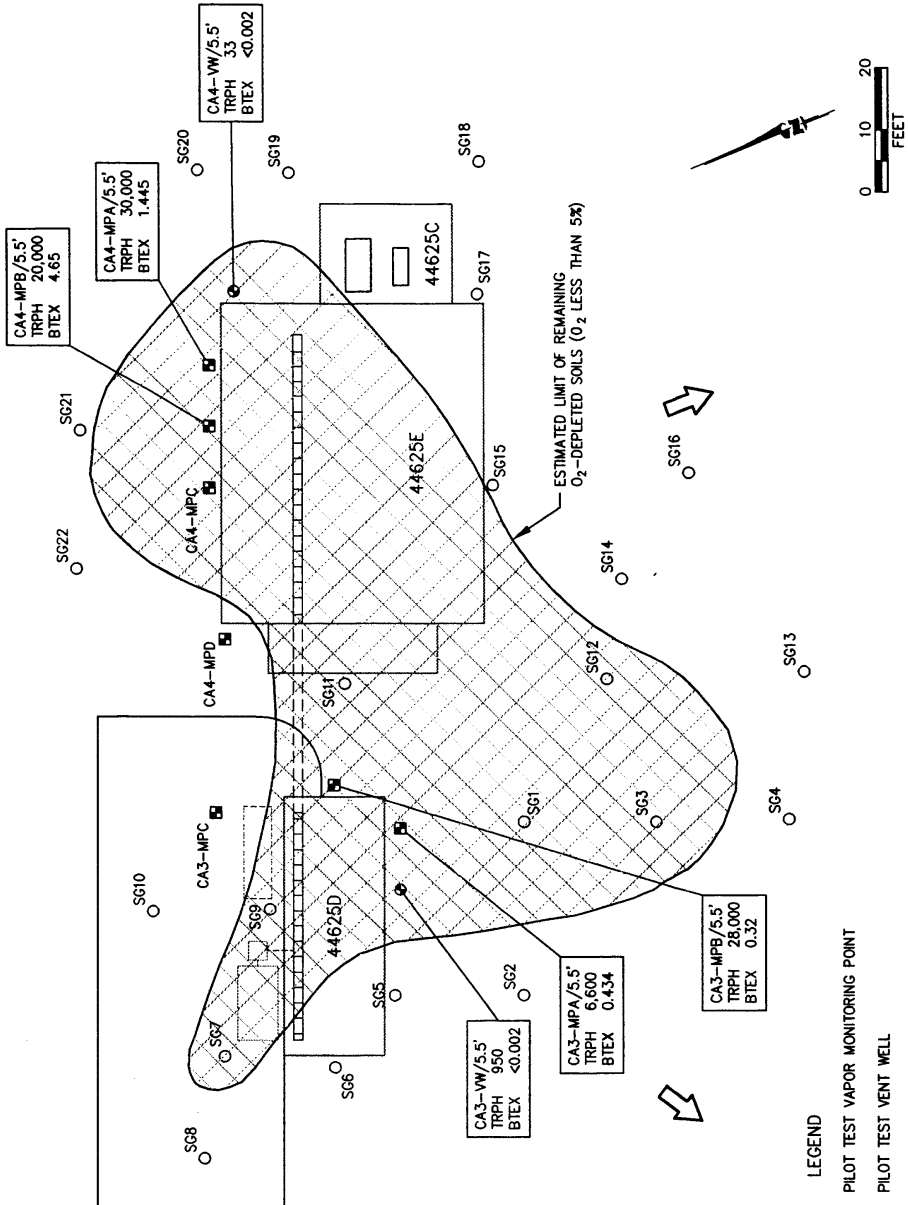

FIGURE 2.8
ONE-YEAR BIOVENTING
SOIL AND SOIL GAS SAMPLING
LOCATIONS AND RESULTS

Facilities 44625D and 44625E
Cape Canaveral AFS, Florida

PARSONS
ENGINEERING SCIENCE, INC.
Denver, Colorado

NOTE: SOIL ANALYTICAL RESULTS ARE FROM SAMPLES COLLECTED AFTER 1 YEAR OF BIOVENTING TREATMENT. FOR ANALYTICAL RESULTS PRIOR TO TREATMENT, SEE FIGURES 2.2 AND 2.3.

- LEGEND**
- CA3-MPA [square symbol]
 - CA3-VW [circle with dot symbol]
 - SG [circle symbol]
 - CA4-MPB/5.5' [rectangle symbol]
 - TRPH [circle symbol]
 - BTEX [circle with cross symbol]
- PILOT TEST VAPOR MONITORING POINT
PILOT TEST VENT WELL
SOIL GAS SAMPLING POINT (JUNE 96)
SOIL SAMPLING RESULTS (DECEMBER 96)
SOIL SAMPLE ID/DEPTH (FEET BELOW GROUND SURFACE)
TOTAL RECOVERABLE PETROLEUM HYDROCARBONS (418.1) IN mg/kg
BENZENE, TOLUENE, ETHYLBENZENE, AND TOTAL XYLENES (SW8020) IN mg/kg
GROUNDWATER FLOW DIRECTION

SECTION 3

BIOVENTING PILOT TESTING RESULTS

The objectives of the initial bioventing pilot tests at Facilities 44625D and 44625E were to:

- Assess the potential for supplying oxygen throughout the contaminated soil profile;
- To determine the rate at which indigenous microorganisms will degrade petroleum hydrocarbons when stimulated by oxygen-rich soil gas at this site; and
- To evaluate the potential for sustaining these rates of biodegradation until hydrocarbon contamination is remediated below regulatory approved standards.

Because bioventing has been demonstrated to be a feasible technology for this site, the pilot test data were used to design a full-scale remediation system (Section 4) to remediate fuel-contaminated soils at the site, to minimize potential releases to groundwater, and to assure that contaminant levels throughout the site are below state regulatory standards.

3.1 PILOT-SCALE SYSTEM CONFIGURATION

Single-VW pilot-scale bioventing systems were installed at Facilities 44625D and 44625E (one system at each site) between 23 and 30 December 1993. Locations of the VW and MPs for each site are shown on Figures 2.1 and 2.2. At Facility 44625D, the VW (CA3-VW) screen was set between 3 and 8 feet bgs. Three multi-depth MPs, CA3-MPA, CA3-MPB, and CA3-MPC, were installed at distances from CA3-VW of 10 feet, 20 feet, and 32 feet, respectively. Site-specific construction details for the VW and MPs installed at Facility 44625D are listed in Table 3.1.

One VW (CA4-VW) and three multi-depth MPs (CA4-MPA, CA4-MPB, and CA4-MPC) were installed at Facility 44625E during the same period in December 1993 (Figures 2.1 and 2.3). A fourth MP, CA4-MPD, was installed at the site in December 1994 at the request of FDEP to quantify the potential for vapor migration at the site. Locations of the VW and the four MPs are shown on Figure 2.1. The VW at the site was installed adjacent to the northeastern corner of Facility 44625E. The screen was set between 3 and 8 feet bgs. The four MPs, CA4-MPA, CA4-MPB, CA4-MPC, and CA4-MPD, were installed at distances from CA4-VW of 12 feet, 22 feet, 32 feet, and 57 feet, respectively. All four MPs were located along the northern edge of Facility 44625E. Site-specific construction details for the VW and MPs installed at Facility 44625E are contained in Table 3.1.

TABLE 3.1
PILOT-SCALE VW AND MP CONSTRUCTION DATA
FACILITIES 44625D AND 44625E
CAPE CANAVERAL AS, FLORIDA

Well ID #	Borehole Total Depth (feet bgs) ^{a/}	Screened Interval(s) (feet bgs)	Filter Pack Interval(s) (feet bgs)	Bentonite Interval(s) (feet bgs)	Grout Interval (feet bgs)
<u>Facility 44625D</u>					
CA3-VW	8	3.0 - 8.0	2.0 - 8.0	1.0 - 2.0	0.0 - 1.0
CA3-MPA	5.5	2.5 - 3.0 5.0 - 5.5	2.0 - 3.0 4.5 - 5.5	1.0 - 2.0 3.0 - 4.5	0.0 - 1.0
CA3-MPB	5.5	2.5 - 3.0 5.0 - 5.5	2.0 - 3.0 4.5 - 5.5	1.0 - 2.0 3.0 - 4.5	0.0 - 1.0
CA3-MPC	5.5	2.5 - 3.0 5.0 - 5.5	2.0 - 3.0 4.5 - 5.5	1.0 - 2.0 3.0 - 4.5	0.0 - 1.0
<u>Facility 44625E</u>					
CA4-VW	8	3.0 - 8.0	2.0 - 8.0	1.0 - 2.0	0.0 - 1.0
CA4-MPA	5.5	2.5 - 3.0 5.0 - 5.5	2.0 - 3.0 4.5 - 5.5	1.0 - 2.0 3.0 - 4.5	0.0 - 1.0
CA4-MPB	5.5	2.5 - 3.0 5.0 - 5.5	2.0 - 3.0 4.5 - 5.5	1.0 - 2.0 3.0 - 4.5	0.0 - 1.0
CA4-MPC	5.5	2.5 - 3.0 5.0 - 5.5	2.0 - 3.0 4.5 - 5.5	1.0 - 2.0 3.0 - 4.5	0.0 - 1.0
CA4-MPD	5.5	2.5 - 3.0 5.0 - 5.5	2.0 - 3.0 4.5 - 5.5	1.0 - 2.0 3.0 - 4.5	0.0 - 1.0
<u>Facility 1748</u>					
Background MP	5.5	2.5 - 3.0 5.0 - 5.5	2.0 - 3.0 4.5 - 5.5	1.0 - 2.0 3.0 - 4.5	0.0 - 1.0

^{a/} bgs = below ground surface.

Each VW was constructed using 4-inch inside-diameter (ID), Schedule 40 polyvinyl chloride (PVC) casing and slotted screen (0.030-inch slot size). The annular space adjacent to the screen was filled with 6-20 sieve size silica sand (filter pack material) from the bottom of the screen to approximately 1 foot above the top of the screen. To prevent preferential air movement to the surface during pilot testing, a 1-foot thick annular bentonite seal was emplaced on top of the VW filter pack. The annulus of the well was then filled with a bentonite/cement grout to approximately 6 inches bgs. The VWs were completed with 12-inch-diameter well boxes set in 2-foot-square concrete pads. Air was supplied from the blowers to the VWs using aboveground 1.5-inch-diameter galvanized steel pipe (ES, 1994).

Each MP was constructed using 0.5-inch-diameter, Schedule 80 PVC casing and 0.5-inch-diameter slotted screen intervals (0.020-inch slot size). Two casing strings/screens were installed in each MP borehole to provide monitoring points at variable depths within the contaminant levels. Each of the screened intervals was 6 inches in length and was centered in a 1-foot thick layer of 6-20 sieve size silica sand (filter pack material). These filter pack intervals were sealed above and below with bentonite to prevent short circuiting of injected air. A sampling valve was attached to the top of each casing string. In MPA and MPC at each of the two facilities, thermocouples were installed adjacent to the screens at the shallow and deep depths to allow measurement of soil temperature (ES, 1994).

A background MP was installed to monitor soil gas conditions in clean, uncontaminated soil. The MP was installed at nearby Facility 1748 at Cape Canaveral AS. No contamination was observed in the soil or detected by an OVA at this location. The background MP was installed following procedures described in the AFCEE bioventing protocol document (Hinchee *et al.*, 1992). The centers of the screened intervals at the MP are located at 3.0 and 5.5 feet bgs.

Fixed, 1.0-horsepower (HP) Gast® regenerative blower units (model R4) were installed at Facility 44625D and Facility 44625E for the 1-year pilot tests. The regenerative blower units were installed in December 1993, and began operation after regulatory approval for pilot testing was granted in October 1994. During startup, both systems were configured to inject approximately 10 to 20 standard cubic feet per minute (scfm) into each of the pilot test VWs.

3.2 INITIAL SOIL GAS CHEMISTRY

Prior to initiating air injection, the VWs and all MPs were purged until O₂ levels had stabilized, and then initial O₂, CO₂, and TVH concentrations were sampled using portable field meters as described in the AFCEE bioventing protocol document (Hinchee *et al.*, 1992). Depleted O₂ levels and increased CO₂ levels were found in soil gas at the VWs and at all MP screened intervals, indicating soil contamination and natural biological activity in contaminated soil. The initial soil gas chemistry results measured at Facilities 44625D and 44625E are summarized in Table 3.2.

TABLE 3.2
INITIAL SOIL GAS CONDITIONS
FACILITIES 44625D AND 44625E
CAPE CANAVERAL AS, FLORIDA

Sample Location	Depth (feet bgs)	O ₂ (percent)	CO ₂ (percent)	Laboratory TVH-jf (ppmv) ^{a/}	Field TVH (ppmv) ^{b/}
<u>Facility 44625D</u>					
CA3-VW	3-6.5 ^{c/}	0.0	16.0	350	200
CA3-MPA	5.5	0.0	15.8	510	260
CA3-MPB	5.5	0.0	15.9	NS ^{d/}	280
CA3-MPC	5.5	0.0	16.9	330	200
<u>Facility 44625E</u>					
CA4-VW	3-6.5 ^{c/}	11.5	8.0	0.25	60
CA4-MPA	5.5	0.0	16.9	320	120
CA4-MPB	5.5	0.0	16.0	NS	260
CA4-MPC	5.5	0.0	16.0	590	300
CA4-MPD	5.5	NA ^{e/}	NA	NA	NA
<u>Facility 1748</u>					
Background MP	3.0	20.5	0.5	NS	0.0
	5.5	20.3	0.7	NS	0.0

^{a/} TVH-jf = total volatile hydrocarbons as jet fuel (USEPA Method TO-3); ppmv = parts per million, volume per volume.

^{b/} TVH = total volatile hydrocarbons (field instrument).

^{c/} Water table at approximately 6.5 feet below ground surface during time of survey.

^{d/} NS = not sampled.

^{e/} NA = not available; initial soil gas survey was performed in January 1994; MPD was installed in December 1994.

In contrast, soil gas from the background MP had O₂ concentrations of 20.5 percent and 20.3 percent, and CO₂ concentrations of 3.0 and 5.5 percent at the 3.0' and 5.5-foot bgs depths (ES, 1994). These initial soil gas results demonstrated that O₂ depletion and CO₂ accumulation in contaminated soils resulted from biodegradation of hydrocarbon contaminants rather than from degradation of natural organic carbon or from abiotic processes.

3.3 *IN SITU* BIODEGRADATION RATES

Periodic *in situ* respiration testing has been conducted to estimate the biodegradation rates of indigenous bacteria in contaminated subsurface soils. Table 3.3 shows the results of three *in situ* respiration testing events conducted as part of the bioventing pilot tests (initial, 6-month, and 1-year) at Facilities 44625D and 44625E.

The initial and 1-year *in situ* respiration tests were performed by injecting ambient air (20.8 percent oxygen) at a rate of approximately 1 scfm into selected MP screened intervals for at least 20 hours in order to oxygenate surrounding soils. After air injection was ceased, O₂, CO₂, and TVH soil gas levels in selected screened intervals were measured. The bioventing systems had been turned off for several days prior to the 1-year test to allow soil gas to reach equilibrium. The 6-month *in situ* respiration tests were performed by turning off the blower systems and monitoring O₂, CO₂, and TVH levels in selected screened intervals.

Results from the *in situ* respiration tests indicated that the VWs and all of the MPs are screened in hydrocarbon-contaminated soils that have active microorganism populations. The generally higher rates observed in June 1995 correlate with an increase in soil temperature and bioactivity. The biodegradation rate estimates presented in Table 3.3 are based on calculated air-filled porosities (L of air per kg of soil) and a stoichiometric ratio of 3.5 mg of oxygen consumed for every 1 mg of fuel biodegraded.

3.4 OXYGEN INFLUENCE/AIR PERMEABILITY

Air permeability/radius of oxygen influence tests were performed at the two bioventing pilot test sites to determine the pressure response in the formation induced by pressurizing the VWs and to determine the volume of subsurface soils that could be oxygenated from air injection into a single VW. The depth and radius of oxygen influence in the subsurface resulting from air injection into the VW is the primary design parameter for extended bioventing systems. The pilot test data determine the volume of soil that can be oxygenated at a given flow rate and VW screen configuration.

The air permeability test was conducted at Facility 44625D on 8 February 1993, according to protocol document procedures. Air was injected into CA3-VW for approximately 4 hours at a flow rate of 64 scfm with an average pressure at the well head of 21 inches of water. Due to the rapid pressure response and the short length of time required to achieve steady-state conditions at the MPs, the steady-state response method was used to calculate air permeability values, as detailed in the protocol document (Hinchee *et al.*, 1992). Using the steady-state method, the permeability value for site soils is approximately 79 Darcys, typical for the sands that are

TABLE 3.3
RESPIRATION AND DEGRADATION RATES
FACILITIES 44625D AND 44625E
CAPE CANAVERAL AS, FLORIDA

Location-Depth (feet below ground surface)	Initial (January 1994) ^{a/}		6-Month (June 1995) ^{d/}		1-Year (December 1995) ^{e/}				
	K _o (% O ₂ /hour)	Degradation Rate (mg/kg/year) ^{b/}	Soil Temperature (°C)	K _o (% O ₂ /hour)	Degradation Rate (mg/kg/year)	K _o (% O ₂ /hour)	Degradation Rate (mg/kg/year)	Soil Temperature (°C)	
Facility 44625D									
CA3-MPA-3	NS ^{b/}	NC ^{b/}	NS	0.37	1,400	31.0	0.28	500	NS
CA3-MPA-5.5	0.40	2,400	21.2	0.25	950	27.8	NS	NC	NS
CA3-MPB-3	NS	NC	NS	0.47	1,900	NS	0.37	840	NS
CA3-MPB-5.5	0.26	1,600	NS ^{d/}	0.55	2,300	NS	NS	NC	NS
CA3-MPC-3	NS	NC	NS	0.28	1,100	28.8	0.05	110	NS
CA3-MPC-5.5	0.50	3,100	21.4	1.02	4,100	28.2	NS	NC	NS
Facility 44625E									
CA4-MPA-3	NS	NC	NS	0.28	1,200	31.4	0.18	370	NS
CA4-MPA-5.5	0.19	1,200	20.8	0.30	1,200	29.7	NS	NC	NS
CA4-MPB-3	NS	NC	NS	1.38	5,700	NS	0.50	1,200	NS
CA4-MPB-5.5	0.16	930	NS	1.50	6,200	NS	NS	NC	NS
CA4-MPC-3	NS	NC	NS	NS ^{b/}	NC	NS	1.38	3,400	NS
CA4-MPC-5.5	0.17	1,000	20.9	NS ^{b/}	NC	NS	NS	NC	NS

^{a/} Initial respiration testing performed in January 1994, but system operation did not begin until October 1994.

^{b/} Milligrams of hydrocarbons per kilogram of soil per year.

^{c/} Average soil temperature during respiration test.

^{d/} Assumes moisture content of the soil is average of initial and final moistures.

^{e/} Unable to perform respiration testing at 5.5 foot depths due to flooding/elevated water table.

^{f/} NS = not sampled.

^{g/} NC = not calculated.

^{h/} Unable to perform 6-month respiration test due to limited oxygen influence at this monitoring point.

predominant at the site (see Figure 2.2). The calculated permeability value indicates that the site soils are sufficiently permeable to air for the bioventing technology.

The change in soil gas O₂ levels during the air permeability test was measured at MPC, located 32 feet from CA3-VW. Increases in soil gas oxygen levels occurred at this most distant MP, indicating that the entire targeted pilot-scale treatment area was being effectively oxygenated by the single VW.

The air permeability test at the Facility 44625E site was conducted on 8 February 1993, according to protocol document procedures. Air was injected into CA4-VW for approximately 3 hours at a flow rate of 55 scfm with an average pressure at the well-head of 29 inches of water. Due to the rapid pressure response and the short length of time required to achieve steady-state conditions at the MPs, the steady-state response method was used to calculate air permeability values, as detailed in the protocol document (Hinchee *et al.*, 1992). Using the steady-state method, the permeability value for site soils was estimated to be 50 Darcys, typical for the sands that predominate at the site (see Figure 2.3). The calculated permeability value indicates that the site soils are sufficiently permeable to air for the bioventing technology.

An increase in the O₂ concentration in soil gas at MPC, located 32 feet from the VW, was measured at the conclusion of the 3-hour permeability test. This increase indicated that the single VW successfully distributed O₂ to a radial distance of at least 30 feet at all depths.

3.5 SOIL AND SOIL GAS SAMPLING RESULTS

Soil and soil gas samples were collected during the installation of the pilot-scale bioventing systems in December 1993 and January 1994 to determine baseline contaminant concentrations at the VW and MP locations. Samples were collected again in December 1995, after 1 year of bioventing (system operation did not begin until after regulatory approval was granted in October 1994). Soil samples were collected at the same depths originally sampled from boreholes immediately adjacent to the original boreholes, and soil gas samples were collected from the discrete MP intervals originally sampled. The bioventing systems were turned off 25 days prior to collecting soil gas samples to allow the soil gas composition to approach equilibrium. As shown in Tables 3.4 and 3.5, significant reductions in petroleum hydrocarbon concentrations were observed at both facilities.

At Facility 44625D, soil gas TVH concentrations at the CA3-VW and CA3-MPA were reduced from 350 and 510 parts per million, volume per volume (ppmv) to 0.18 and 4.4 ppmv, respectively. At CA3-MPC, soil gas TVH concentrations were reduced from 330 to 0.090 ppmv over the extended treatment period. Very low concentrations of BTEX were detected in initial and 1-year soil gas samples collected at the site (Table 3.4). Soil sampling results for Facility 44625D exhibited similar trends, with TRPH concentrations decreasing at two of the three sampling locations. The TRPH concentration at CA3-MPB appeared to increase during the 1-year pilot test. This is most likely the result of sampling a slightly different soil intervals during the initial and 1-year sampling events. As with soil gas, little to no BTEX was detected above method detection limits in either initial or 1-year soil samples collected from the site.

TABLE 3.4
FACILITY 44625D
SOIL AND SOIL GAS ANALYTICAL RESULTS
CAPE CANAVERAL AS, FLORIDA

Analyte (Units) ^a	Sample Locations-Depth (feet below ground surface)					
	CA3-VW-3-8		CA3-MPA ^b		CA3-MPC ^b	
	Initial ^c	1-Year ^d	Initial (MPA-5.5)	1-Year (MPA-3)	Initial (MPC-5.5)	1-Year (MPC-3)
Soil Gas Hydrocarbons						
TVH (ppmv)	350	0.18	510	4.4	330	0.090
Benzene (ppmv)	0.26	<0.002	0.80	<0.002	<0.025	<0.002
Toluene (ppmv)	0.19	<0.002	0.32	<0.002	0.10	<0.002
Ethylbenzene (ppmv)	<0.014	<0.002	<0.050	<0.002	<0.025	<0.002
Xylenes (ppmv)	1.3	<0.002	2.2	<0.002	1.2	<0.002
Soil Hydrocarbons						
TRPH (mg/kg)	8,440	950	8,000	6,600	15,000	28,000
Benzene (mg/kg)	<0.27	<0.0005	<0.53	<0.0025	<1.3	<0.060
Toluene (mg/kg)	<0.27	<0.0005	<0.53	<0.0025	<1.3	<0.060
Ethylbenzene (mg/kg)	<0.27	<0.0005	<0.53	0.049	<1.3	<0.060
Xylenes (mg/kg)	1.3	0.0005	1.7	0.38	<1.8	0.14
Moisture (%)	7.7	19.5	6.1	19.2	5.1	17.1

^a TVH = total volatile hydrocarbons; ppmv = parts per million, volume per volume;

TRPH = total recoverable petroleum hydrocarbons; mg/kg = milligrams per kilogram.

^b Unable to collect 1-year sample at 5.5 foot depth due to elevated water table and flooding of this interval.

^c Initial soil gas samples collected on January 14, 1994.

^d Final soil gas samples collected on December 22, 1995 following 1 year of bioventing. Blower system was shut down approximately 30 days prior to soil gas sampling to allow soil gas concentrations to come to equilibrium with soils.

^e Initial soil samples collected on December 30, 1993.

^f Final soil samples collected following 1 year of bioventing collected on December 23, 1995.

At Facility 44625E, soil gas TVH concentrations were reduced by three orders of magnitude at CA4-MPA and by less than one order of magnitude at CA4-VW and CA4-MPC over the extended treatment period (Table 3.5). Soil gas and soil BTEX concentrations were low during initial and 1-year sampling. Soil sampling results for TRPH indicated mixed results. One-year concentrations of TRPH remained constant or increased in samples collected near CA4-VW and CA4-MPA. A slight reduction in TRPH concentrations was observed at CA4-MPB. The lack of positive effects of bioventing may be the result of sampling variability and groundwater table fluctuations that smear contamination throughout the soil sampling interval. The most convincing evidence for bioventing at these sites is the continuing biological demand for oxygen and production of carbon dioxide as a byproduct of fuel respiration.

3.6 POTENTIAL AIR EMISSIONS

The long-term potential for air emissions from full-scale bioventing operations at this site is considered low because of the low injection rate proposed for extended operation (1 scfm per foot of well screen), the asphalt/building cover over much of the affected area, and the fact that initial soil gas BTEX levels were less than 10 ppmv (Tables 3.4 and 3.5). Health and safety monitoring was conducted during the air permeability testing using an OVA sensitive to 1-ppmv increases in TVH. No emissions in excess of 1 ppmv were detected in the worker breathing zone during the 3 to 4 hours of air injection. Because the potential for air emissions is highest during the initial hour of air injection, the long-term emission potential is considered negligible.

3.7 RECOMMENDATION FOR FULL-SCALE BIOVENTING

Based on the results of the 1-year bioventing pilot tests, AFCEE has provided funding for the design and installation of an expanded bioventing system that will remediate the remaining contaminated soils associated with Facilities 44625D and 44625E. The full-scale bioventing system will satisfy the recommendations of the Contamination Assessment Report and Addendum previously prepared for the site (CH₂M Hill, 1994 and 1995). AFCEE has retained Parsons ES to continue bioventing services at Cape Canaveral AS and to complete the design and installation of an expanded bioventing system. Based on the initial pilot test results, available analytical data, and recently completed soil gas sampling, Parsons ES has prepared a conceptual, full-scale upgrade design that will employ two new horizontal VWs. Four additional MPs also will be installed to ensure that oxygen is being delivered to contaminated soils throughout the targeted treatment area (see Figure 2.8). Section 4 provides details on the design, construction, and operation of the expanded system. A design package has been prepared for construction of the system and is included in Appendix A of this RAP.

SECTION 4

EXPANDED BIOVENTING SYSTEM

The purpose of the expanded bioventing system is to provide oxygen to stimulate aerobic biodegradation of the remaining soil contamination present at Facilities 44625D and 44625E at Cape Canaveral AS. Two new horizontal air injection VWs will be used to provide atmospheric air to oxygen-depleted, unsaturated, smear zone contaminated soils at the site. Four additional MPs also will be installed to ensure that oxygen is being delivered to contaminated soils. System design details are provided in Appendix A.

4.1 OBJECTIVES

Following its installation, the primary objectives for the expanded bioventing system will be to:

- Optimize the system to fully aerate the unsaturated subsurface in areas at the site designated for bioventing remediation;
- Reduce the existing contaminant levels in soils to below the FDEP cleanup criteria (Chapter 62-770, FAC). Applicable FDEP criteria include 100 mg/kg for TRPH, 1,000 $\mu\text{g}/\text{kg}$ for PAHs, and 100 $\mu\text{g}/\text{kg}$ for VOCs. Concentrations of BTEX in soils at Facilities 44625D and 44625E already meet the applicable regulatory cleanup criteria.
- Eliminate the potential for contamination to migrate and adversely affect groundwater quality at these sites by removing the contaminant source mass from vadose soils; and
- Provide the most cost-effective remediation alternative for these facilities.

4.2 BASIS OF DESIGN

Site investigation data, pilot test data, and experience at other bioventing sites provide the main elements of the basis of design. The expanded bioventing system was designed to provide oxygen to areas of significant soil contamination. Both vadose zone and smear zone contaminated soils have been targeted.

Pilot test data, such as operating pressure and radius of oxygen influence, were considered during design development. These data were considered in the spacing of VWs and sizing of a full-scale blower system. In addition to the pilot test data from these sites, experience at other sites with similar soil types was considered in design development. Experience at other sites was used only where there were shortcomings

in the pilot test data, such as uncertainty in accuracy of the required flow rate for a horizontal, rather than vertical, VW.

The significant design parameters and considerations are as follow:

- A radius of oxygen influence of 70 feet was used to design the spacing and placement of two horizontal VWs. This area of influence was based on site-specific radius-of-oxygen influence calculations; observations from pilot testing performed at the facilities; and past experience with similar horizontal VW systems at Patrick AFB, Florida. Both the BX Service Station site and site FTA-2 at Patrick AFB have similar hydrogeologic conditions as the Facilities 44625D and 44625E site and employ horizontal VWs for bioventing. In addition, the BX service station and the Facilities 44625D and 44625E site share similar surface features (i.e., asphalt and concrete pavement at the surface). Data from the Patrick AFB sites are applicable to the design of the Facilities 44625D and 44625E system.
- An air injection pressure of 10 inches of water was assumed in sizing the full-scale bioventing blower. This injection pressure is consistent with the injection pressure used at site FTA-2, Patrick AFB.
- An air injection flow rate of 50 scfm per VW was assumed based on site-specific calculations and experience at site FTA-2, Patrick AFB, Florida, where a 0.4 scfm per linear foot injection rate is producing a lateral oxygen influence of greater than 30 feet.

The presence of an office building immediately south of the Facilities 44625D and 44625E site has influenced the proposed placement of the horizontal air injection VWs. Horizontal VWs will be placed south of the concrete pads so that soil gas advection beneath the pads will be toward the north, away from the office building, minimizing the possibility of mobilizing VOCs into the building.

Based on 1-year soil and soil gas sampling results (Figure 2.8), a 70 foot radius of oxygen influence will effectively remediate hydrocarbon-contaminated, oxygen-depleted soils at Facilities 44625D and 44625E. The air injection rates and blower size necessary to achieve the 70 foot radius of influence was determined from the volume of soil designated for bioventing treatment, oxygen utilization rates observed during 1-year pilot testing, and an assumed 20 percent air-filled porosity. The total volume of soil designated for full-scale bioventing treatment is approximately 292,000 cubic feet. Based on a maximum observed oxygen utilization rate of 1.50 percent per hour (Table 3.3), injected air should reach the contaminated soil perimeter approximately 11.4 hours following injection and contain a minimum 5 percent oxygen residual. From these requirements, a flow rate of 46.0 scfm is necessary for effective bioventing treatment of the contaminated soil. Supporting calculations are provided in Appendix B.

Based on the calculations presented in Appendix B, a design air injection rate of 50 scfm will be achieved with a Gast[®] 2-HP R5 regenerative blower. The blower has the capacity to supply air at a rate of 60 scfm for each of two VWs (120 scfm total flow) at an estimated injection pressure of 10 inches of water. Because the majority of the site

is covered with concrete or asphalt pavement, the calculations in Appendix B assume that all air flow is horizontal and minimal short circuiting to the surface will occur. Design assumptions and calculations for the full-scale system at Facilities 44625D and 44625E closely approximate the actual measured performance of the horizontal VW system in place at Site FTA-2, Patrick AFB, Florida. The site at Facilities 44625D and 44625E is known to have hydrogeologic conditions very similar to the Patrick AFB FTA-2 site.

The existing 1-HP blowers installed during pilot testing will be removed, and the new 2-HP blower will be installed at the southeastern corner of Facility 44625E. The locations of the four additional MPs were selected such that they will provide information as to the extent of smear zone contamination, will be useful in evaluating the magnitude of contaminant reduction through soil gas sampling, and will provide important oxygen influence data. The proposed MPs will be located near the periphery of the expected area of influence of the new horizontal VWs. The MPs will be used to verify the area of soil oxygenated by the full-scale bioventing system. Figure 4.1 shows the proposed locations of the new blower, VWs, and MPs.

4.3 SYSTEM DESIGN

The proposed upgrade to the existing bioventing systems at Facilities 44625D and 44625E will incorporate the existing MPs, two new horizontal VWs, and four additional MPs. The additional VWs will be installed to ensure proper oxygen influence throughout the area of identified soil contamination. The VW locations were selected to make use of existing MPs, to provide coverage of the area of oxygen-depleted soils (Figure 2.8 and Figure 4.1), and to minimize the possibility of mobilizing VOCs into the office building south of the site.

In the event oxygen influence is not evident at the MPs on the north side of Facility 44625E (CA4-MPA, CA4-MPB, CA4-MPC, and CA4-MPD) following system installation and after the first week of initial operation, an additional horizontal VW will be installed on the north side of Facility 44625E. Figure 4.2 shows the contingency full-scale system configuration. The existing blower on the east side of Facility 44625E will be used to inject air into the third horizontal VW, if the new 2-HP blower has insufficient capacity, or if header pipe installation on the east side of Facility 44625E is not possible. Air flow to the three VWs will be optimized to oxygenate the full areal extent of contaminated soils and to minimize VOC migration from the site.

The new VWs will be 2 inches in diameter and each will be screened for 50 linear feet with 0.030-inch slotted screen. The VW trench configuration and other design details are included in the design package provided in Appendix A. The VWs will be manifolded using 1.5-inch-diameter, Schedule 80 PVC as the conduit for the injected air flow from the blower to the proposed VWs. The piping will be connected to the new 2.0-HP regenerative blower and will be set at a depth of 2 feet bgs. A separate, manual flow control valve and flow measurement port will be included in the lines connecting each VW to the blower to allow independent adjustment of the air flow to each VW. The blower and valving will be housed in weatherproof enclosures for protection from the elements and for security purposes.

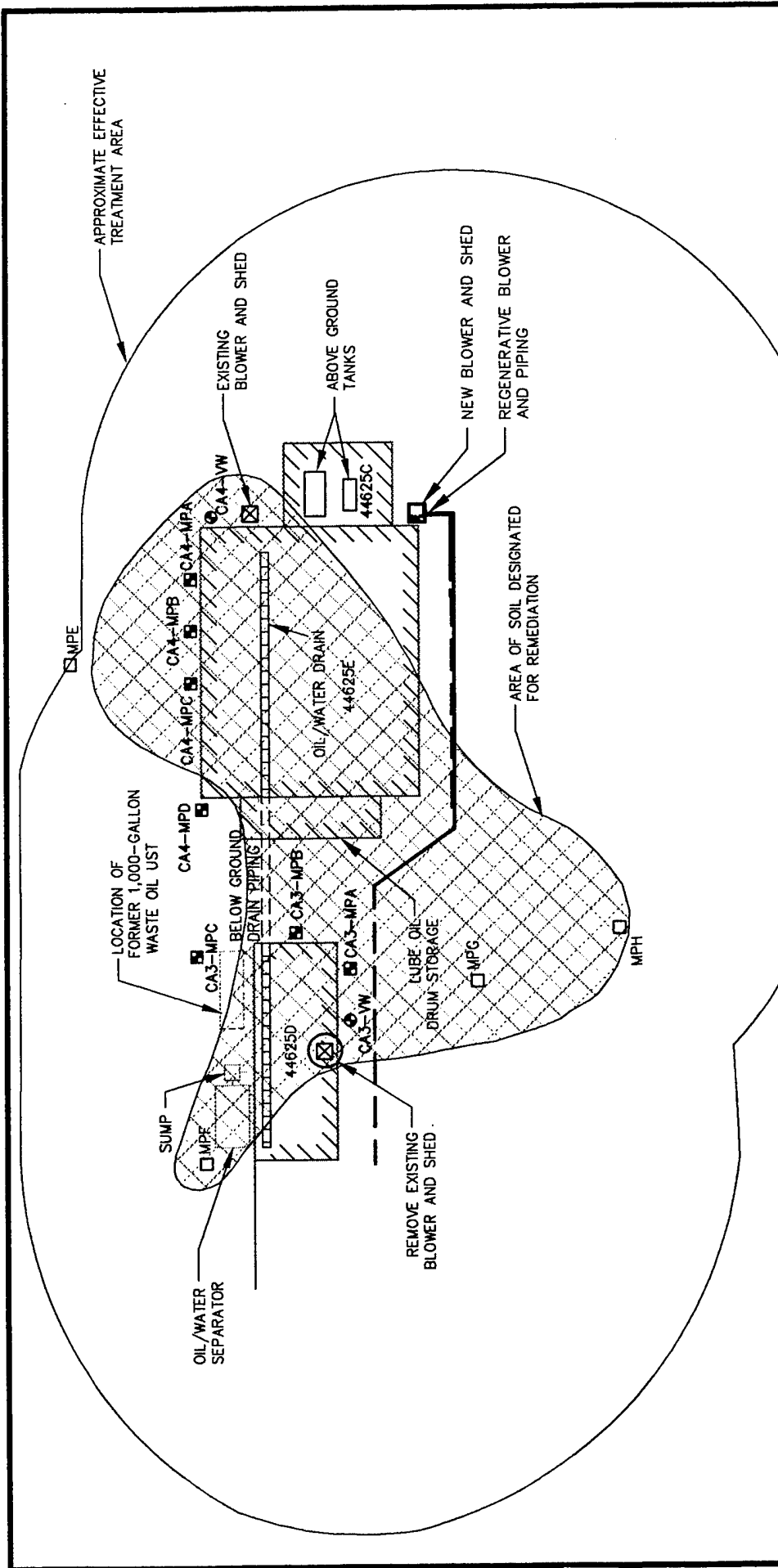

LEGEND

- PILOT TEST VAPOR MONITORING POINT
- PROPOSED VAPOR MONITORING POINT
- ⊙ PILOT TEST VENT WELL
- PROPOSED HEADER PIPE
- - - PROPOSED HORIZONTAL VENT WELL SCREENED INTERVAL
- ▨ CONCRETE PAD

FIGURE 4.1

PROPOSED FULL-SCALE BIOVENTING SYSTEM CONFIGURATION

Facilities 44625D and 44625E
Cape Canaveral AS, Florida

PARSONS ENGINEERING SCIENCE, INC.
Denver, Colorado

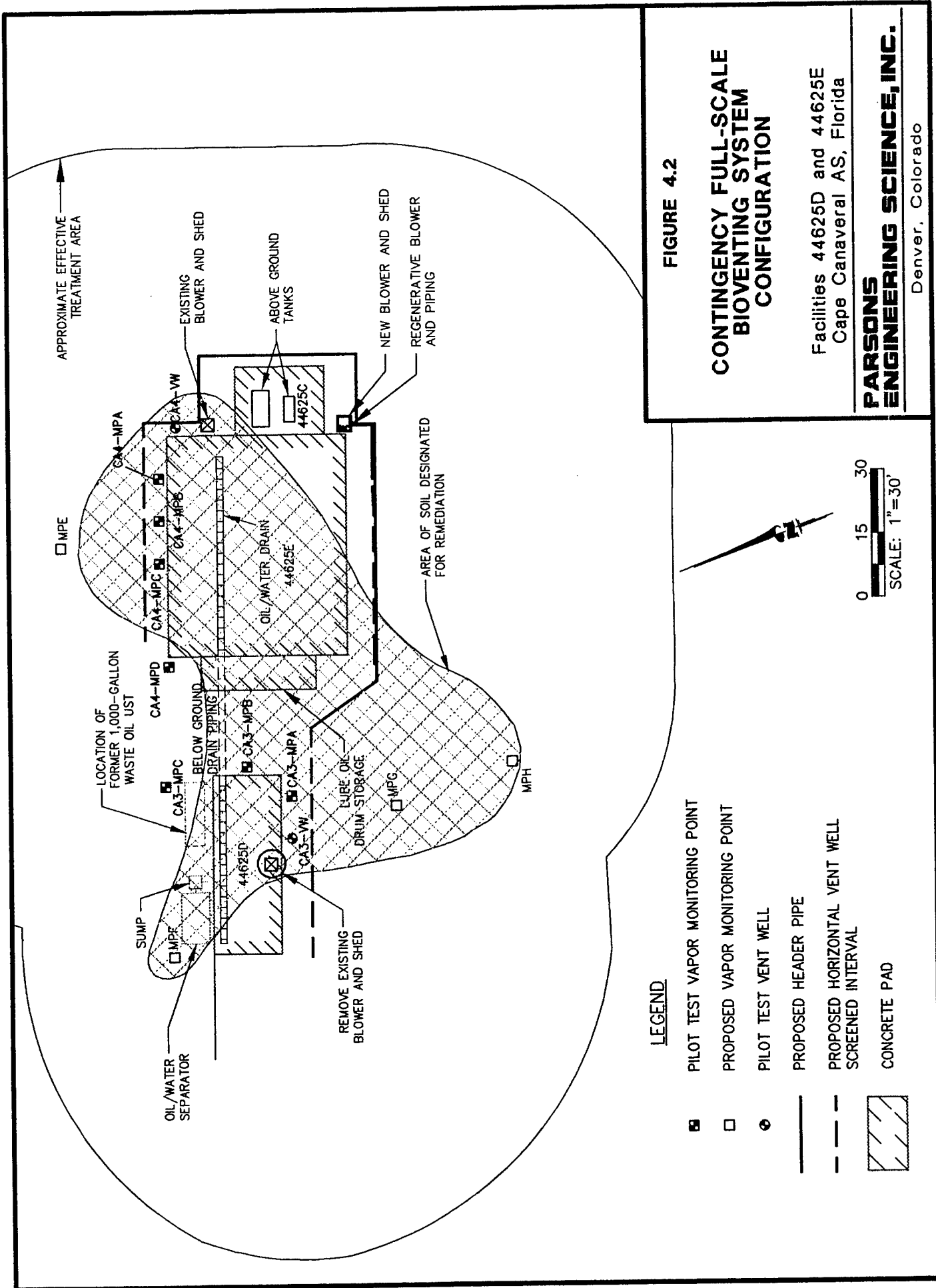

FIGURE 4.2

CONTINGENCY FULL-SCALE BIOVENTING SYSTEM CONFIGURATION

Facilities 44625D and 44625E
Cape Canaveral AS, Florida

PARSONS ENGINEERING SCIENCE, INC.
Denver, Colorado

LEGEND

- PILOT TEST VAPOR MONITORING POINT
- PROPOSED VAPOR MONITORING POINT
- ⊙ PILOT TEST VENT WELL
- PROPOSED HEADER PIPE
- - - PROPOSED HORIZONTAL VENT WELL SCREENED INTERVAL
- ▨ CONCRETE PAD

4.4 PROJECT SCHEDULE

The following schedule for the bioventing system upgrade is contingent upon timely approval of this final RAP by AFCEE and Patrick AFB personnel.

Event	Start Date	End Date	Duration (working days)
Submit Draft Remedial Action Plan and Design Package to AFCEE and Patrick AFB	NA	21 August 1996	NA
AFCEE and Patrick AFB Review Period	22 August 1996	6 September 1996	12 days
Respond to Comments on Draft	9 September 1996	16 October 1996	27 days
Submit Work Permit (digging permit) Request	NA	13 September 1996	NA
Submit Final RAP to AFCEE, Patrick AFB, and FDEP ^{a/} .	NA	16 October 1996	NA
Construction of Expanded System/System Startup	28 October 1996	8 November 1996	10 days
Confirmation of Oxygen Influence/Contingency Installation (if necessary)	11 November 1996	15 November 1996	5 days
Complete Construction Drawings/O&M Manual	18 November 1996	27 December 1996	30 days

^{a/} Final copies for FDEP to be submitted by Patrick AFB.

4.5 SYSTEM OPERATION, MAINTENANCE, AND MONITORING

Following system installation, Parsons ES engineers will perform system startup and optimization. An operations and maintenance (O&M) plan and record drawings of the system will be prepared and submitted to AFCEE and Patrick AFB following system startup and optimization.

4.5.1 System Optimization and Operation

At startup of the full-scale system, it will be necessary to optimize the air injection rate and to ensure proper operation of the blower system. Flow rate optimization is accomplished by gradually increasing the flow to each VW until soil gas oxygen concentrations at all MP depth intervals reach a minimum concentration of approximately 5 percent. Oxygen levels in excess of 5 percent at the outer MPs may indicate that the volume of air passing through the soil exceeds the biological oxygen utilization rate and the injection rates would be reduced to avoid excessive volatilization and minimize the potential for off-site vapor migration. The blower will be checked to ensure that it is producing the required flow rate and pressure for air injection.

Following flow rate optimization, the system will run continuously and will require minimal maintenance, as described below. Parsons ES has been contracted by AFCEE to provide 1 year of system O&M support under Option 1 of the Extended Bioventing Project. O&M support will include performing any system repairs should the bioventing system fail to operate properly.

4.5.2 System Maintenance

System maintenance requirements for the proposed bioventing system are minimal because the regenerative blower is virtually maintenance-free. The only recurring maintenance required is a monthly check of the air filter, which is generally replaced when the vacuum across the inlet filter reaches a reading 10 to 15 inches of water greater than the reading with a clean filter. The time period between filter changes is dependent on site conditions, and is typically every 3 to 6 months. The O&M manual will further detail maintenance requirements. Parsons ES is responsible for 1 year of maintenance support under Option 1 of the Extended Bioventing Project. Should the blower system give indications of an electrical or mechanical problem, such as a significant change in outlet pressure, abnormal noises from the blower, or system failure, during the first year of operation, Parsons ES will be responsible for repairing the system. Prior to mobilizing to the site, Parsons ES may request that an AS electrician verify that adequate power is being supplied to the blower motor. Once adequate power to the motor has been verified, Parsons ES will take the necessary actions to repair the blower system. Following the year of maintenance support by Parsons ES, Patrick AFB personnel, or personnel appointed by Patrick AFB, will be responsible for system maintenance.

4.5.3 System Performance Monitoring

Routine monitoring of the bioventing system will include system checks of blower operation, including outlet pressures, inlet vacuum, and exhaust temperature every 2 weeks. These system checks will be performed by Patrick AFB technicians or personnel appointed by Patrick AFB.

To provide baseline data against which the progress of remediation can be evaluated, soil and soil gas samples will be collected during installation of the full-scale bioventing system. These data will be used along with previously collected data to provide a basis for future comparison.

Soil samples will be collected from all new MP boreholes and VW trenches during installation of the full-scale bioventing system components. Samples will be collected at 2-foot intervals from all boreholes, and will be screened in the field for organic vapors using a OVA. Grab samples will be collected from the bottom of the horizontal VW trenches at 5-foot intervals along the length of each of the trenches. As many as ten soil samples will be sent to a laboratory for analysis of BTEX by Method SW8020A and total extractable petroleum hydrocarbons (TEPH) by Method SW8015A modified (for diesel fuel) and up to five soil samples will be analyzed for PAHs by Method SW8270. Soil samples from the most contaminated intervals based on OVA headspace readings will be sent to Inchcape Testing in Richardson, Texas for analysis.

Soil gas sampling will be conducted at all MPs and VWs prior to system startup to establish baseline O₂, CO₂, and TVH levels using field instruments. In addition, soil gas samples from as many as ten locations will be forwarded to Air Toxics Ltd. of Folsom, California for analysis of TVH (as jet fuel) and BTEX by USEPA Method TO-3. The locations of these samples will be determined based on the field screening results. The intervals exhibiting the highest TVH concentrations based on OVA readings will be sampled for laboratory analysis.

System performance monitoring by Parsons ES under Option 1 of the Extended Bioventing Project will include *in situ* respiration testing during a site visit after 1 year of full-scale system operation. Soil gas samples also will be collected from the same MPs sampled during full-scale system installation and reanalyzed for BTEX and TVH using USEPA Method TO-3. No soil sampling will be performed under Option 1 of the Extended Bioventing Project.

Prior to performing the 1-year respiration tests and soil gas sampling, the blower will be turned off for 30 days to allow soil gas to equilibrate so that 1-year full-scale data can be compared to initial soil gas data. Air will be injected into VWs or MPs for 20 hours, and then shut off. Oxygen uptake will be monitored in the MPs for approximately 72 hours to measure the rate at which oxygen concentrations decrease in the soil gas. These data will then be used to estimate the current biodegradation rates and to evaluate the progress of contaminant removal and system effectiveness. As the fuel in the soil is depleted, the respiration activity of the indigenous microorganisms is reduced, and slower O₂ utilization rates result. The use of O₂ utilization rates and soil gas chemistry as indicators of remaining contaminant concentration decreases the likelihood of premature closure soil sampling events.

System monitoring and *in situ* respiration test data will be analyzed to determine the progress of soil remediation. Estimates of contaminant reduction and time remaining to complete soil remediation will be based on the data collected during the respiration tests (O₂ utilization rates), quantitative estimates of the long-term biodegradation rates, and decreases in soil gas concentrations.

SECTION 5

HANDLING OF INVESTIGATION-DERIVED WASTES

Cutting and soils excavated from the VW trenches will be screened in the field with an OVA. If screening indicates that the soils are clean, they will be spread on the ground surface adjacent to the facilities. If screening indicates that the soils are contaminated, they will be placed in either US Department of Transportation (DOT) approved 55-gallon drums or a roll-off container and disposed of in accordance with the policies of Cape Canaveral AS and Patrick AFB. The majority of the soils excavated for the installation of the horizontal VWs will be placed back into the trenches and compacted. It is anticipated that 4.5 cubic yards of soil cuttings will be generated during installation of the full-scale bioventing system. Cape Canaveral AS and Patrick AFB are responsible for final disposition of contaminated soil.

Decontamination of augers, sampling equipment, and all other items requiring decontamination will be performed at a temporary decontamination area set up at the site. Decontamination water will be placed in DOT-approved 55-gallon drums and temporarily stored at the site. After completion of drilling activities, the water will be disposed of in accordance with the policies of Cape Canaveral AS and Patrick AFB.

SECTION 6

BASE AND STATION SUPPORT REQUIREMENTS

The following support from Patrick AFB and Cape Canaveral AS is needed prior to the arrival of the drillers and the Parsons ES team:

- Assistance in obtaining a Base digging permit.
- Obtaining all necessary regulatory permits for the VWs and MPs.
- Assistance in obtaining any air permits required.
- Provide a copy of any Base soils management plan and/or sampling and analysis plan.
- Provide any paperwork required to obtain gate passes and security badges for drilling personnel and two Parsons ES employees. If required by the Base, vehicle passes will be needed for two Parsons ES trucks, one drill rig, and two drilling support trucks. These passes must be valid for the expected duration of drilling operations (about 2 weeks) and the full-scale system installation and startup (about 1 week).
- A potable water supply for well construction and decontamination activities.

During full-scale bioventing, Base or Station personnel will be required to check the blower system once every 2 weeks to ensure that it is operating properly, to record air injection pressures and temperatures, and to replace air filters as needed. Parsons ES will provide an O&M procedures manual and a brief training session.

1. If a blower stops working, notify Mr. Steve Archabal of Parsons ES - Phoenix at (602) 852-9110, Mr. John Ratz of Parsons ES - Denver at (303) 831-8100, or Capt Ed Marchand of AFCEE at (210) 536-4364.
2. Arrange site access for a Parsons ES technician to conduct respiration testing and soil gas sampling approximately 1 year after full-scale system installation and start up.

SECTION 7
POINTS OF CONTACT

Mr. Hugh Houghton
45 CES/CEV
1224 Jupiter St.
Patrick AFB, FL 32925-3343
(407) 494-9263
Fax (407) 494-5965

Mr. John Ratz, Project Manager
Parsons Engineering Science, Inc.
1700 Broadway, Suite 900
Denver, CO 80290
(303) 831-8100
Fax: (303) 831-8208

Mr. Marty Faile
AFCEE/ERT
3207 North Road, Building 532
Brooks AFB, TX 78235-5363
(210) 536-4342
Fax: (210) 536-4330

Mr. Steve Archabal, Site Manager
Parsons Engineering Science, Inc.
3875 North 44th Street, Suite 250
Phoenix, AZ 85018
(602) 852-9110
Fax: (602) 852-9112

Captain Edward Marchand
AFCEE/ERT
3207 North Road, Building 532
Brooks AFB, TX 78235-5363
(210) 536-4364
Fax: (210) 536-4330

Mr. John Hall, Site Engineer
Parsons Engineering Science, Inc.
257 A 28 Road
Grand Junction, CO 81503
(970) 244-8829
Fax: (970) 244-8829

SECTION 8

REFERENCES

- CH₂M Hill. 1992. *Hazwrap, Martin Marietta Phase I Contamination Assessment, Cape Canaveral Air Force Station, Orlando, Florida, April/July.*
- CH₂M Hill, 1994. *Contamination Assessment Report, Facility 44625A/D Cape Canaveral Air Station.* August.
- CH₂M Hill, 1995. *Contamination Assessment Report Addendum, Response to FDEP Comments, Facility 44625 Cape Canaveral Air Station.* June.
- Florida Department of Environmental Protection (FDEP) 1990. *No Further Action and Monitoring Only Guidelines for Petroleum Contaminated Sites.* October.
- Hinchee, R.E., S.K. Ong, R.N. Miller, D.C. Downey, and R. Frandt. 1992. *Test Plan and Technical Protocol for a Field Treatability Test for Bioventing.* January.
- Engineering-Science, Inc. (ES) 1994. *Part I, Bioventing Pilot Test Work Plan and Part II, Draft Interim Pilot Test Results Report for Facilities 1748, 44625D, and 44625E, Cape Canaveral Air Force Station, Florida.* May.

APPENDIX A
DESIGN PACKAGE

APPENDIX B
DESIGN CALCULATIONS

Client Cape Canaveral Facilities 44625DE
 Subject Calculate treatment area

Job No. 726876.26342
 By J. Hall
 Checked C. Snyder

Sheet 1 of 1
 Date 9/16/86
 Rev. D

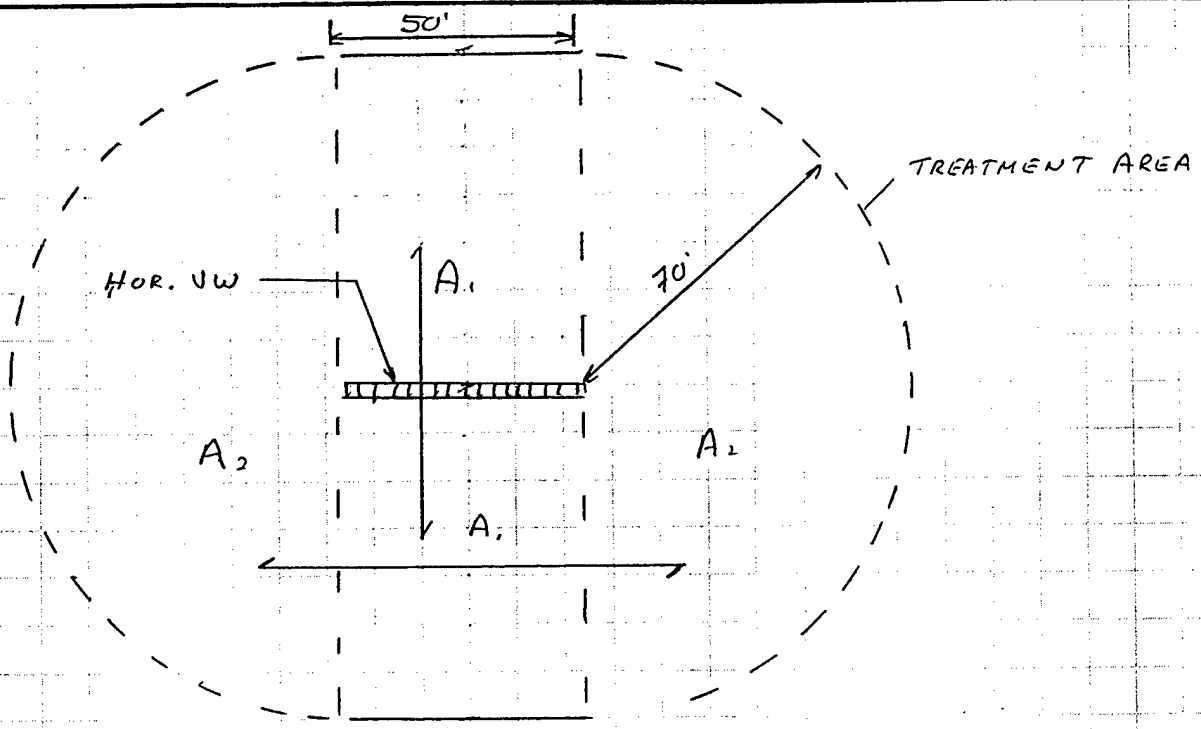

$$A_{TOT} = A_1 + A_2 = (50' \times 140') + (\pi 70'^2) = 22,400 \text{ ft}^2 \checkmark$$

Vol. soil (Assume 6.5' unsaturated thickness) = $22,400 \text{ ft}^2 \times 6.5' = 146,000 \text{ ft}^3$

• Air filled volume (assume 20% air filled porosity) = $146,000 \times 0.2 = 29,000 \text{ ft}^3$

• Time for O_2 to be reduced from 20.7 to 5% @ $K_0 = \frac{1.50\%}{1.38\%} / \text{hr}$ (Tab 6.3.3)
 $(20.7 - 5) / \frac{1.50}{1.38} = \frac{11.4 \text{ hr}}{10.5 \text{ hr}} \checkmark$ (max K_0)

• Calculate req'd air injection rate, (R)

$$R \text{ ft}^3/\text{min} = 29,000 \text{ ft}^3 / (10.5 \text{ hr} \times 60 \text{ min/hr}) = \frac{46.0}{42.4} \text{ cfm} \checkmark$$

- use 50 ~~45~~ scfm for design flow \checkmark

- blower capacity, (R5, 2HP) approx 120 scfm (60 scfm/JW) \checkmark

- use R5, 2HP blower
- use radius of O_2 influence = 70' min.

**CONSTRUCTION DRAWINGS FOR
EXPANDED BIOVENTING SYSTEM
FACILITIES 44625D AND 44625E
CAPE CANAVERAL AIR STATION**

**PREPARED FOR
AFCEE
SEPTEMBER 1996**

DRAWING INDEX

DRAWING NO	DRAWING NAME
G-0-1	TITLE SHEET AND SITE LAYOUT
G-0-2	LEGEND, STANDARD TRENCH DETAILS, HORIZONTAL VENT WELL, AND MONITORING POINT STANDARD DETAILS
G-0-3	BLOWER P & ID
G-0-4	BLOWER PIPING LAYOUT DETAIL
G-0-5	BLOWER SHED FIELD INSTALLATION DETAIL AND BLOWER SHED CONSTRUCTION DETAIL

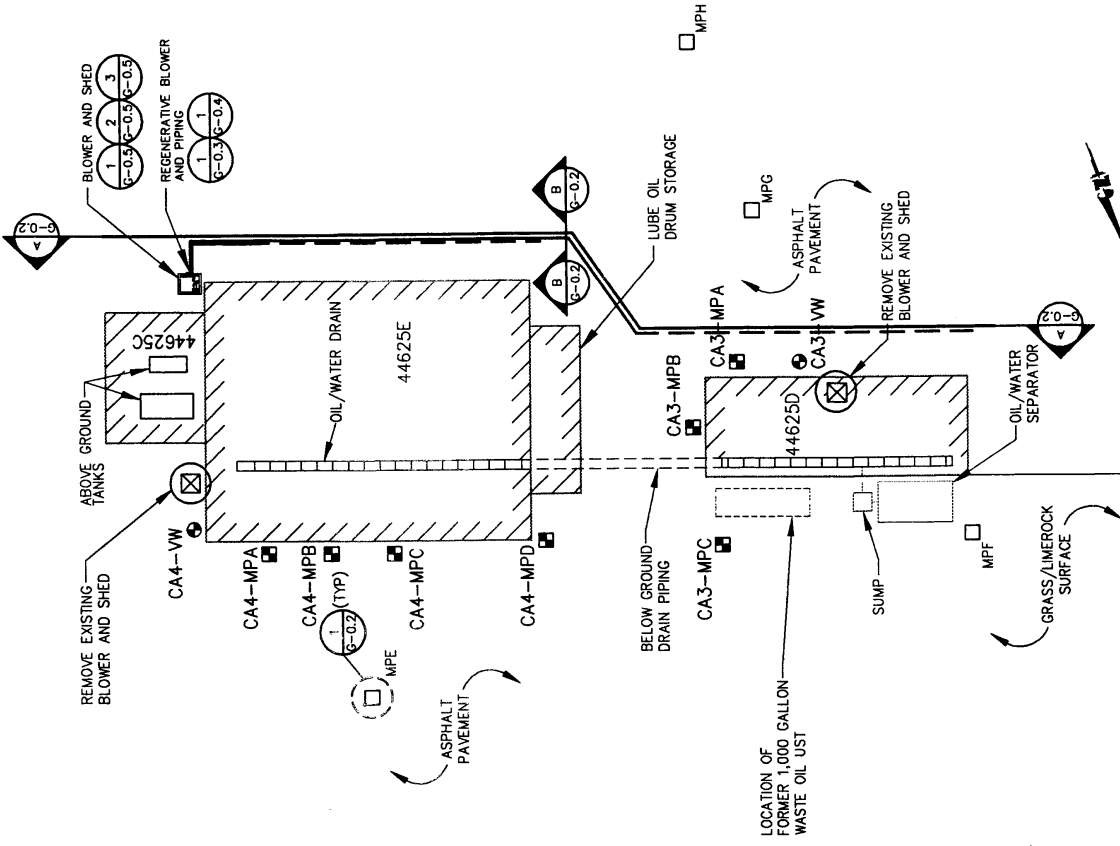

SITE LAYOUT
SCALE: 1" = 20'

Date	By	Description
9/27/96	AFCEE	DESIGNED SA
9/27/96	AFCEE	DRAWN MW
9/27/96	AFCEE	CHECKED
9/27/96	AFCEE	APPROVED
9/27/96	AFCEE	REVISED
9/27/96	AFCEE	REVISED

Job No. 726876.28242
Designed SA
Drawn MW
Checked
Approved
Rev
Date

PARSONS ENGINEERING SCIENCE, INC.
Denver, Colorado
(303) 851-8100

**AIR FORCE CENTER FOR
ENVIRONMENTAL EXCELLENCE
(AFCEE)
EXPANDED BIOVENTING SYSTEM
FACILITIES 44625D AND
44625E
CAPE CANAVERAL AIR STATION**

DRAWING NO	REV
G-0.1	A

ABBREVIATIONS

AU AIR INJECTION
 APPX APPROXIMATE
 ASTM AMERICAN SOCIETY OF TESTING AND MATERIALS
 & AND
 AT CENTER BACK MOUNT
 CLR CLEAR
 DIA DIAMETER
 CLR CLEAR
 EBB EXPLORATORY BORING
 ECC ECCENTRIC
 EW EACH WAY
 FDN FLAT ON TOP
 FTT FEMALE PIPE THREAD
 FTT FTT
 FUL FULCRANIZED STEEL
 FOR EXAMPLE
 GALV GALVANIZED
 LAX LOWER MOUNT
 LAX LOWER MOUNT
 MIL MILLIMETER
 MIN MINIMUM
 MP MONITORING POINT
 MP MALE PIPE THREAD
 NO. # NUMBER
 NPT NATIONAL PIPE THREAD
 NPT NOT TO SCALE
 ON CENTER
 OD OUTSIDE DIAMETER
 PVC POLYVINYL CHLORIDE
 PW PROPOSED WELL
 RED REDUCER
 REF REFERENCE
 SCH SCHEDULE
 S SOCKET
 SPVC SLOTTED POLYVINYL CHLORIDE
 ST STL
 TYP TYPICAL
 UNDERGROUND STORAGE TANK
 UST UNDERGROUND STORAGE TANK
 VV VENT WELL
 W/ WITH
 WN WELD NECK

MATERIAL LEGEND

ASPHALT
 BENTONITE
 BENTONITE/CEMENT GROUT
 BENTONITE PELLETS
 BUILDING (EXISTING)
 COMPACTED BACKFILL
 COMPACTED BASE STONE
 CONCRETE
 PEA GRAVEL
 SAND
 UNDISTURBED SOIL

PIPE MATERIAL
 GALV GALVANIZED STEEL
 PVC POLYVINYL CHLORIDE
 SPVC SCREENED POLYVINYL CHLORIDE

SYMBOLS

--- PROPOSED HEADER PIPE
 --- PROPOSED SCREENED INTERVAL
 CA3-MPA
 MPE
 CA3-VW

PERMANENT VAPOR MONITORING POINT
 PROPOSED VAPOR MONITORING POINT
 EXISTING VENT WELL

SECTION DESIGNATION
 SECTION NAME
SECTION CUT
 SCALE: NTS
 SCALE

DETAIL NAME
 DETAIL NUMBER
DETAIL DESCRIPTION
 SCALE: NTS
 SCALE

LEGEND, STANDARD TRENCH DETAILS, HORIZONTAL VENT

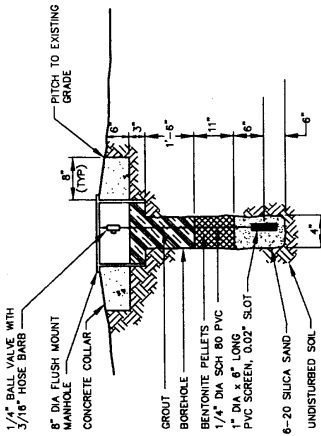

VAPOR MONITORING POINT CONSTRUCTION DETAIL
 NOT TO SCALE

LEGEND, STANDARD TRENCH DETAILS, HORIZONTAL VENT

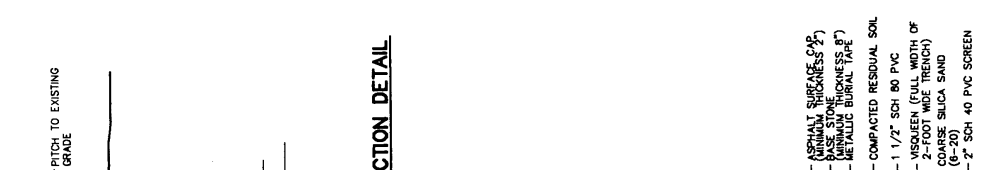

SECTION
 NOT TO SCALE

PIPE MATERIAL

GALV GALVANIZED STEEL
 PVC POLYVINYL CHLORIDE
 SPVC SCREENED POLYVINYL CHLORIDE

ABBREVIATIONS

AU AIR INJECTION
 APPX APPROXIMATE
 ASTM AMERICAN SOCIETY OF TESTING AND MATERIALS
 & AND
 AT CENTER BACK MOUNT
 CLR CLEAR
 DIA DIAMETER
 CLR CLEAR
 EBB EXPLORATORY BORING
 ECC ECCENTRIC
 EW EACH WAY
 FDN FLAT ON TOP
 FTT FEMALE PIPE THREAD
 FTT FTT
 FUL FULCRANIZED STEEL
 FOR EXAMPLE
 GALV GALVANIZED
 LAX LOWER MOUNT
 LAX LOWER MOUNT
 MIL MILLIMETER
 MIN MINIMUM
 MP MONITORING POINT
 MP MALE PIPE THREAD
 NO. # NUMBER
 NPT NATIONAL PIPE THREAD
 NPT NOT TO SCALE
 ON CENTER
 OD OUTSIDE DIAMETER
 PVC POLYVINYL CHLORIDE
 PW PROPOSED WELL
 RED REDUCER
 REF REFERENCE
 SCH SCHEDULE
 S SOCKET
 SPVC SLOTTED POLYVINYL CHLORIDE
 ST STL
 TYP TYPICAL
 UNDERGROUND STORAGE TANK
 UST UNDERGROUND STORAGE TANK
 VV VENT WELL
 W/ WITH
 WN WELD NECK

MATERIAL LEGEND

ASPHALT
 BENTONITE
 BENTONITE/CEMENT GROUT
 BENTONITE PELLETS
 BUILDING (EXISTING)
 COMPACTED BACKFILL
 COMPACTED BASE STONE
 CONCRETE
 PEA GRAVEL
 SAND
 UNDISTURBED SOIL

PIPE MATERIAL
 GALV GALVANIZED STEEL
 PVC POLYVINYL CHLORIDE
 SPVC SCREENED POLYVINYL CHLORIDE

SYMBOLS

--- PROPOSED HEADER PIPE
 --- PROPOSED SCREENED INTERVAL
 CA3-MPA
 MPE
 CA3-VW

PERMANENT VAPOR MONITORING POINT
 PROPOSED VAPOR MONITORING POINT
 EXISTING VENT WELL

SECTION DESIGNATION
 SECTION NAME
SECTION CUT
 SCALE: NTS
 SCALE

DETAIL NAME
 DETAIL NUMBER
DETAIL DESCRIPTION
 SCALE: NTS
 SCALE

LEGEND, STANDARD TRENCH DETAILS, HORIZONTAL VENT

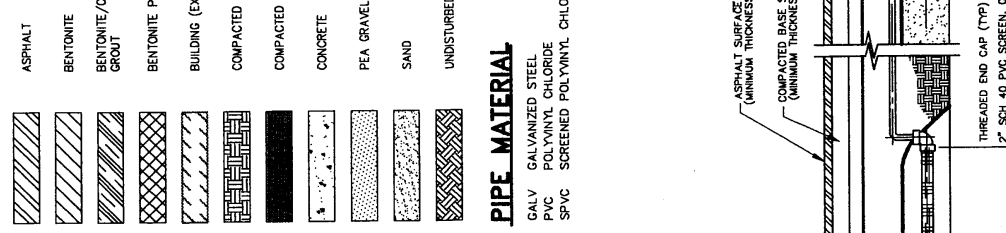

SECTION
 NOT TO SCALE

ABBREVIATIONS

AU AIR INJECTION
 APPX APPROXIMATE
 ASTM AMERICAN SOCIETY OF TESTING AND MATERIALS
 & AND
 AT CENTER BACK MOUNT
 CLR CLEAR
 DIA DIAMETER
 CLR CLEAR
 EBB EXPLORATORY BORING
 ECC ECCENTRIC
 EW EACH WAY
 FDN FLAT ON TOP
 FTT FEMALE PIPE THREAD
 FTT FTT
 FUL FULCRANIZED STEEL
 FOR EXAMPLE
 GALV GALVANIZED
 LAX LOWER MOUNT
 LAX LOWER MOUNT
 MIL MILLIMETER
 MIN MINIMUM
 MP MONITORING POINT
 MP MALE PIPE THREAD
 NO. # NUMBER
 NPT NATIONAL PIPE THREAD
 NPT NOT TO SCALE
 ON CENTER
 OD OUTSIDE DIAMETER
 PVC POLYVINYL CHLORIDE
 PW PROPOSED WELL
 RED REDUCER
 REF REFERENCE
 SCH SCHEDULE
 S SOCKET
 SPVC SLOTTED POLYVINYL CHLORIDE
 ST STL
 TYP TYPICAL
 UNDERGROUND STORAGE TANK
 UST UNDERGROUND STORAGE TANK
 VV VENT WELL
 W/ WITH
 WN WELD NECK

MATERIAL LEGEND

ASPHALT
 BENTONITE
 BENTONITE/CEMENT GROUT
 BENTONITE PELLETS
 BUILDING (EXISTING)
 COMPACTED BACKFILL
 COMPACTED BASE STONE
 CONCRETE
 PEA GRAVEL
 SAND
 UNDISTURBED SOIL

PIPE MATERIAL
 GALV GALVANIZED STEEL
 PVC POLYVINYL CHLORIDE
 SPVC SCREENED POLYVINYL CHLORIDE

SYMBOLS

--- PROPOSED HEADER PIPE
 --- PROPOSED SCREENED INTERVAL
 CA3-MPA
 MPE
 CA3-VW

PERMANENT VAPOR MONITORING POINT
 PROPOSED VAPOR MONITORING POINT
 EXISTING VENT WELL

SECTION DESIGNATION
 SECTION NAME
SECTION CUT
 SCALE: NTS
 SCALE

DETAIL NAME
 DETAIL NUMBER
DETAIL DESCRIPTION
 SCALE: NTS
 SCALE

LEGEND, STANDARD TRENCH DETAILS, HORIZONTAL VENT

SECTION
 NOT TO SCALE

REV	DATE	DESCRIPTION
A	12/21/97	ISSUE DESIGN
B	1/23/98	REVISION
C	1/23/98	REVISION
D	1/23/98	REVISION
E	1/23/98	REVISION
F	1/23/98	REVISION
G	1/23/98	REVISION
H	1/23/98	REVISION
I	1/23/98	REVISION
J	1/23/98	REVISION
K	1/23/98	REVISION
L	1/23/98	REVISION
M	1/23/98	REVISION
N	1/23/98	REVISION
O	1/23/98	REVISION
P	1/23/98	REVISION
Q	1/23/98	REVISION
R	1/23/98	REVISION
S	1/23/98	REVISION
T	1/23/98	REVISION
U	1/23/98	REVISION
V	1/23/98	REVISION
W	1/23/98	REVISION
X	1/23/98	REVISION
Y	1/23/98	REVISION
Z	1/23/98	REVISION

Job No. 726878.26242
 Designed SA
 Drawn MPE
 Checked MPE
 Approved MPE

Rev	Date	Description	By
A	7/2/76	55% DESIGN	

Date
 Rev
 Approved
 Checked
 Drawn
 Designed SA
 Job No. 726876 26242

PARSONS
 ENVIRONMENTAL SCIENCE, INC.
 Denver, Colorado
 (303) 631-8100

AIR FORCE CENTER FOR
 ENVIRONMENTAL EXCELLENCE
 (AFCEE)
 EXPANDED BLOWING SYSTEM
 FACILITIES 44625D AND E
 CAPE CANAVERAL AIR STATION

DRAWING NO
G-0.3
 REV
A
 BLOWER P & ID

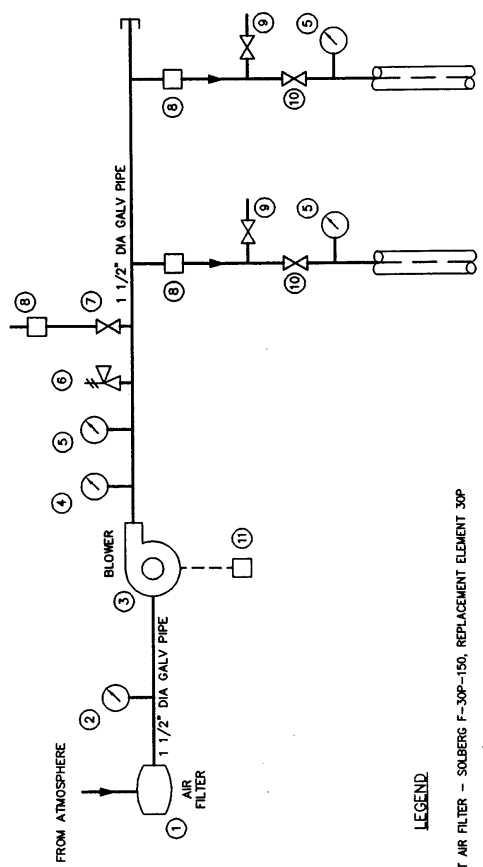

LEGEND

- ① INLET AIR FILTER - SOLBERG F-30P-150, REPLACEMENT ELEMENT 30P
- ② VACUUM GAUGE - GAST® AH497, 2 5/8" DIA, 0-60" H₂O, 1/4" NPT, LM (Part No. AJ497)
- ③ BLOWER - GAST® 2.0 HP RS1250-50, 120 CFM AT 30" H₂O PRESSURE
- ④ TEMPERATURE GAUGE - ASHCROFT, 0-250°F, 1/2" NPT, CBM (Part No. 24606 FROM GRAINGER)
- ⑤ PRESSURE GAUGE - WKA 611.10, 2 1/2" DIA, 0-100" H₂O, 1/4" NPT, CBM (Part No. 9851879)
- ⑥ AUTOMATIC PRESSURE RELIEF VALVE - GAST AG258, SET TO RELEASE AT 55" H₂O PRESSURE
- ⑦ MANUAL PRESSURE RELIEF (BLEED) VALVE - 1 1/2" GATE
- ⑧ FLOW MEASURING PORT FITTED WITH PLUG (1/4"x 1/8" NPT BRASS REDUCING BUSHING, 1/8" NPT BRASS PLUG)
- ⑨ SAMPLING PORT-1/4" BALL VALVE WITH 3/16" HOSE BARB
- ⑩ FLOW CONTROL VALVE - 1 1/2" GATE
- ⑪ STARTER

BLOWER PIPING AND INSTRUMENTATION DIAGRAM

SCALE: NTS



Rev	Date	Description
1	8/21/96	ISSUE DESIGN
2	8/21/96	
3		
4		
5		
6		
7		
8		

Job No. 726876.20242
 Designed SA
 Drawn MW
 Checked JF
 Approved JF
 Date 8/21/96

PARSONS ENGINEERING SCIENCE, INC.
 Denver, Colorado (303) 831-8100

AIR FORCE CENTER FOR ENVIRONMENTAL EXCELLENCE (AFCEE)
 EXPANDED ROVENTING SYSTEM FACILITIES 4425D AND E
 CAPE CANAVERAL AIR STATION

DRAWING NO. **G-04**
 REV. **A**

BLOWER PIPING LAYOUT DETAIL

- NOTES:
1. SHOP CORE HOLES TO PIPING DIMENSIONS
 2. ALL PIPING 1 1/2" DIA. GALVANIZED STEEL UNLESS OTHERWISE NOTED
 3. SEE DRAWING G-05 FOR BLOWER BUILDING DETAILS

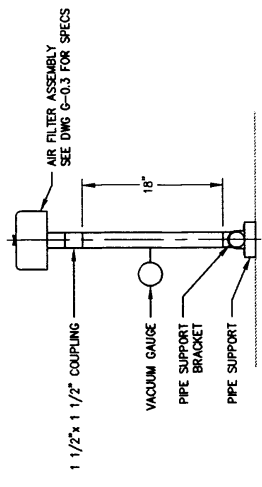

BLOWER INLET PIPING SECTION
 3/4" = 1'-0"

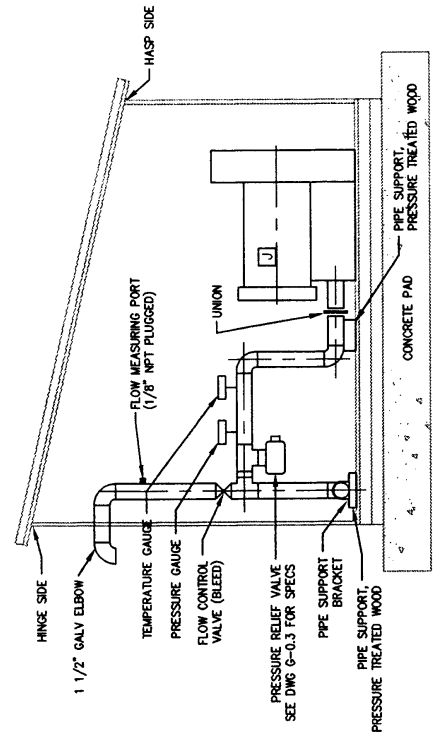

BLOWER OUTLET PIPING SECTION
 3/4" = 1'-0"

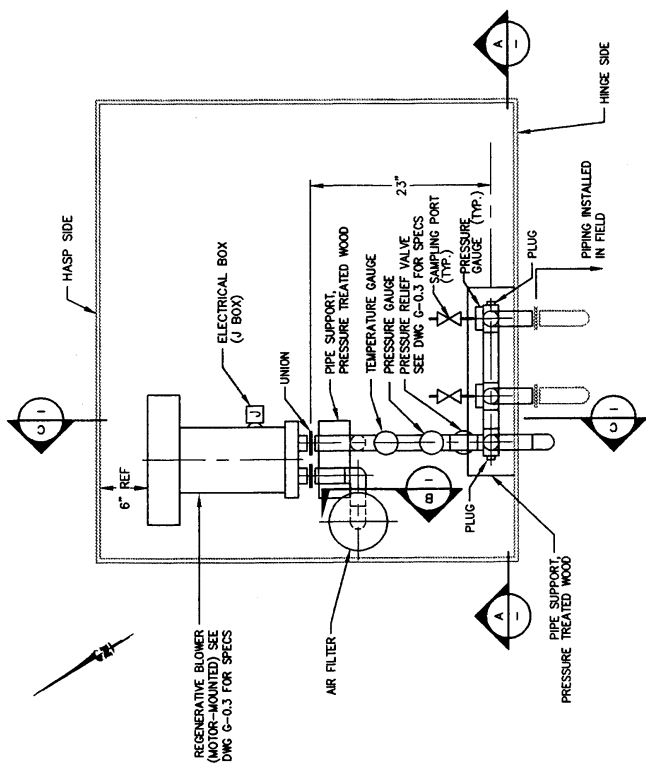

BLOWER PIPING LAYOUT PLAN DETAIL
 3/4" = 1'-0"

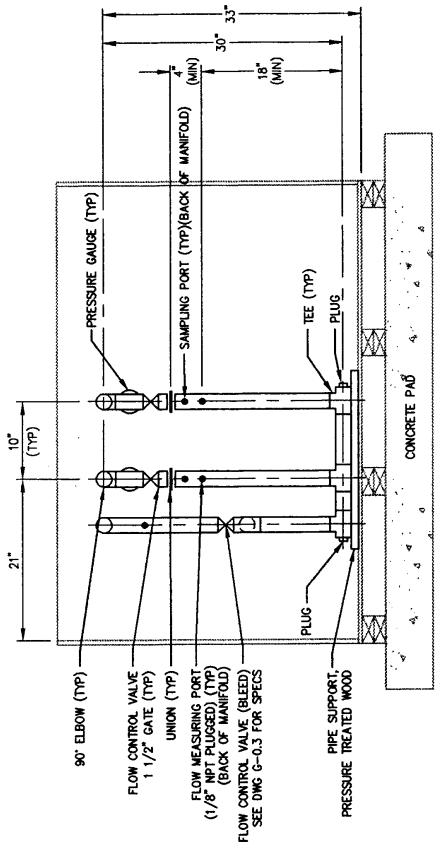

MANIFOLD DETAIL SECTION
 3/4" = 1'-0"

By	
Description	65% DESIGN
Rev	A
Date	8/21/96
Checked	8/21/96
Drawn	8/21/96
Design	8/21/96
Approved	8/21/96
Reg No	228242
Job No	228242

PARSONS
ENVIRONMENTAL SCIENCE, INC.
Denver, Colorado
(303) 831-8100

AIR FORCE CENTER FOR
ENVIRONMENTAL EXCELLENCE
(AFCEE)
EXPANDED BIOVENTING SYSTEM
FACILITIES 44825D AND E
CAPE CANAVERAL AIR STATION

BLOWER SHED FIELD
INSTALLATION DETAIL
AND BLOWER DETAILS
CONSTRUCTION DETAILS

DRAWING NO
G-0-5
REV
A

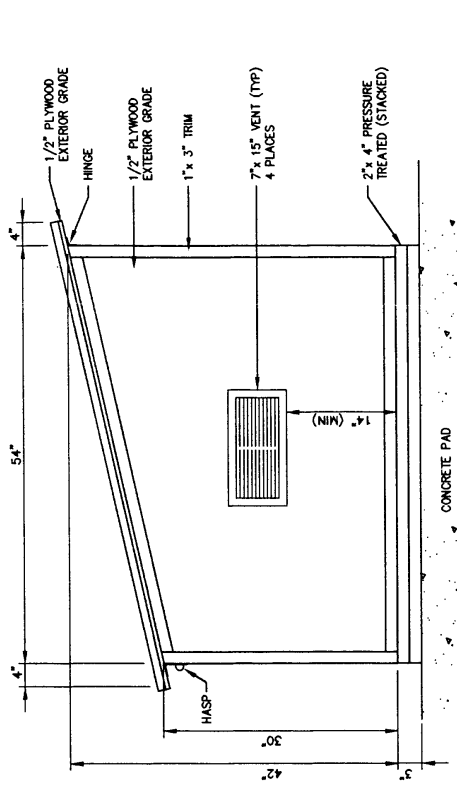

SIDE ELEVATION

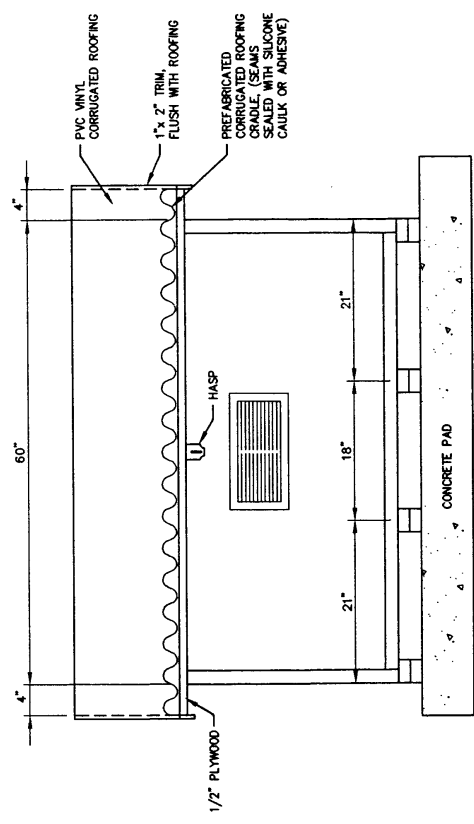

FRONT ELEVATION

- NOTES:
- 2" x 2" FRAME CONSTRUCTION
 - FLOOR CONSTRUCTED OF 3/4" EXTERIOR GRADE PLYWOOD
 - ROOF CONSTRUCTED OF 1/2" EXTERIOR GRADE PLYWOOD COVERED WITH PVC VINYL CORRUGATED ROOFING

BLOWER SHED CONSTRUCTION DETAIL
3/4" = 1'-0"

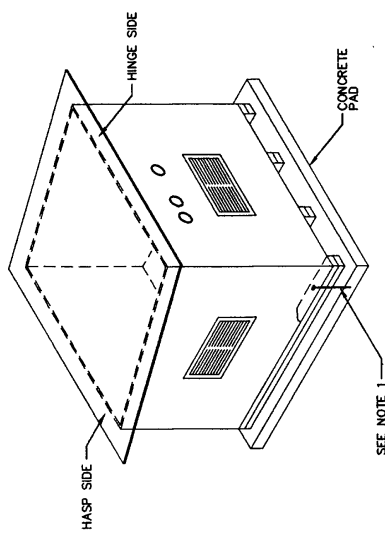

- NOTES:
- FIELD SECURE BLOWER SHED TO CONCRETE PAD AT 4 LOCATIONS BY THRU BOLTING. USE 3/8" x 6" LONG ST STL WEDGE ANCHOR BOLTS

BLOWER SHED FIELD INSTALLATION DETAIL
NOT TO SCALE

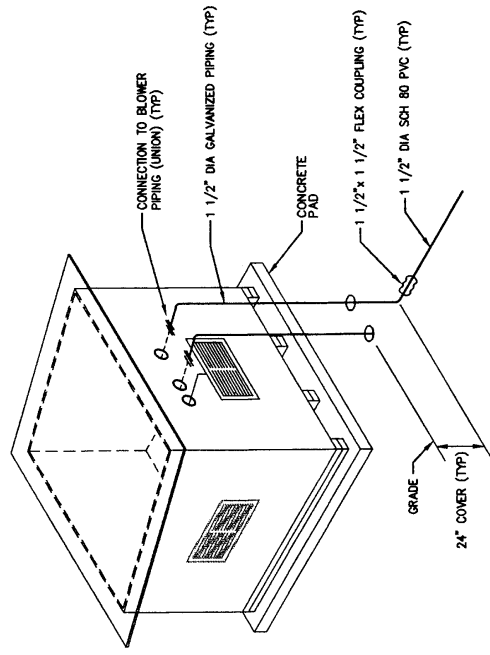

TYPICAL MANIFOLD DISCHARGE PIPING LAYOUT
NOT TO SCALE