

LOAN DOCUMENT

PHOTOGRAPH THIS SHEET

①

DTIC ACCESSION NUMBER

LEVEL

INVENTORY

2 Parts

Pilot Test Work Plan for SWMU...

DOCUMENT IDENTIFICATION

Aug 94

DISTRIBUTION STATEMENT A

Approved for Public Release
Distribution Unlimited

DISTRIBUTION STATEMENT

ACCESSION FOR	
NTIS	GRAM
DTIC	TRAC
UNANNOUNCED	
JUSTIFICATION	
BY	
DISTRIBUTION/	
AVAILABILITY CODES	
DISTRIBUTION	AVAILABILITY AND/OR SPECIAL
A-1	

DISTRIBUTION STAMP

DATE ACCESSIONED

DATE ACCESSIONED

DATE RETURNED

DATE RETURNED

DTIC QUANTITY ORDERED 4

20001208 005

DATE RECEIVED IN DTIC

REGISTERED OR CERTIFIED NUMBER

PHOTOGRAPH THIS SHEET AND RETURN TO DTIC-FDAC

H
A
N
D
L
E

W
I
T
H

C
A
R
E

PART I

**Pilot Test Work Plan for
SWMU #70-Oil/Water Separator No. 326
Cannon AFB, New Mexico**

PART II

**Interim Pilot Test Results Report for
SWMU #70 - Oil/Water Separator No. 326
Cannon AFB, New Mexico**

Prepared For

**Air Force Center for Environmental Excellence
Brooks AFB, Texas**

and

**27 CES/CEV
Cannon AFB, New Mexico**

ES

Engineering-Science, Inc.

August 1994

1700 BROADWAY, SUITE 900
DENVER, COLORADO 80290

AQ M01-02-0479

ES ENGINEERING-SCIENCE

DEFENSE TECHNICAL INFORMATION CENTER REQUEST FOR SCIENTIFIC AND TECHNICAL REPORTS

Title AFCEE Collection

1. Report Availability (Please check one box)

- This report is available. Complete sections 2a - 2f.
- This report is not available. Complete section 3.

2a. Number of Copies Forwarded

1 each

2b. Forwarding Date

July/2000

2c. Distribution Statement (Please check ONE box)

DoD Directive 5230.24, "Distribution Statements on Technical Documents," 18 Mar 87, contains seven distribution statements, as described briefly below. Technical documents MUST be assigned a distribution statement.

- DISTRIBUTION STATEMENT A: Approved for public release. Distribution is unlimited.
- DISTRIBUTION STATEMENT B: Distribution authorized to U.S. Government Agencies only.
- DISTRIBUTION STATEMENT C: Distribution authorized to U.S. Government Agencies and their contractors.
- DISTRIBUTION STATEMENT D: Distribution authorized to U.S. Department of Defense (DoD) and U.S. DoD contractors only.
- DISTRIBUTION STATEMENT E: Distribution authorized to U.S. Department of Defense (DoD) components only.
- DISTRIBUTION STATEMENT F: Further dissemination only as directed by the controlling DoD office indicated below or by higher authority.
- DISTRIBUTION STATEMENT X: Distribution authorized to U.S. Government agencies and private individuals or enterprises eligible to obtain export-controlled technical data in accordance with DoD Directive 5230.25, Withholding of Unclassified Technical Data from Public Disclosure, 6 Nov 84.

2d. Reason For the Above Distribution Statement (in accordance with DoD Directive 5230.24)

2e. Controlling Office

HQ AFCEE

2f. Date of Distribution Statement Determination

15 Nov 2000

3. This report is NOT forwarded for the following reasons. (Please check appropriate box)

- It was previously forwarded to DTIC on (date) and the AD number is
- It will be published at a later date. Enter approximate date if known.
- In accordance with the provisions of DoD Directive 3200.12, the requested document is not supplied because:

Print or Type Name

Laura Peña

Signature

Laura Peña

Telephone

210-536-1431

(For DTIC Use Only)

AQ Number

MD-02-0479

PART I
BIOVENTING PILOT TEST WORK PLAN FOR
SWMU #70 - OIL/WATER SEPARATOR NO. 326

CANNON AFB, NEW MEXICO

Prepared for:

Air Force Center for Environmental Excellence
Brooks AFB, Texas

and

27 CES/CEV
CANNON AFB, NEW MEXICO

Prepared by:

Engineering-Science, Inc.
1700 Broadway, Suite 900
Denver, Colorado 80290

AUGUST 1994

TABLE OF CONTENTS

DRAFT BIOVENTING PILOT TEST WORK PLAN FOR SWMU #70 - OIL/WATER SEPARATOR NO. 326 CANNON AFB, NEW MEXICO

	<u>Page</u>
1.0 Introduction	I-1
2.0 Facility 187.....	I-3
2.1 Site Description	I-3
2.2 Soil Gas Sampling Activities	I-3
3.0 SWMU #70 - Oil/Water Separator No. 326.....	I-3
3.1 Site Description	I-3
3.1.1 Site History and Location	I-3
3.1.2 Site Geology	I-5
3.1.3 Site Contaminants	I-5
3.2 Pilot Test Activities.....	I-5
3.2.1 Layout of Pilot Test Components	I-6
3.2.2 Vent Well.....	I-6
3.2.3 Monitoring Points	I-6
3.2.4 Blower System	I-10
3.2.5 Air Permeability Test.....	I-10
3.2.6 <i>In Situ</i> Respiration Test.....	I-10
3.2.7 Extended Pilot Test Bioventing System	I-12
4.0 Background Monitoring Point	I-12
5.0 Soil and Soil Gas Sampling	I-12
5.1 Soil Samples	I-12
5.2 Soil Gas Samples.....	I-13
6.0 Handling of Drill Cuttings	I-13
7.0 Exceptions to Protocol Procedures.....	I-13
8.0 Base Support Requirements	I-13
9.0 Project Schedule	I-14
10.0 Points of Contact	I-15
11.0 References	I-15

FIGURES

	<u>Page</u>
1.1	Site Locations With Respect To Base I-2
3.1	Site Layout SWMU #70 I-4
3.2	Proposed Vent Well, Monitoring Point, and Blower Locations SWMU #70 I-7
3.3	Proposed Injection Vent Well Construction Detail SWMU #70 I-8
3.4	Proposed Monitoring Point Construction Detail SWMU #70 I-9
3.5	Typical Blower System Instrumentation Diagram for Air Injection SWMU #70..... I-11

**BIOVENTING PILOT TEST WORK PLAN FOR
SWMU #70 - OIL/WATER SEPARATOR NO. 326
CANNON AFB, NEW MEXICO**

1.0 INTRODUCTION

This work plan presents the scope of multiphase bioventing pilot tests for *in situ* treatment of fuel-contaminated soils at solid waste management unit (SWMU) #70 - Oil/Water Separator No. 326 at Cannon Air Force Base (AFB), New Mexico. The location of the sites with respect to the base is shown on Figure 1.1. The pilot test will be performed by Engineering-Science, Inc. (ES). The three primary objectives of the proposed pilot test are: 1) to assess the potential for supplying oxygen throughout the contaminated soil interval, 2) to determine the rate at which indigenous microorganisms will degrade fuel when supplied with oxygen-rich soil gas, and 3) to evaluate the potential for sustaining these rates of biodegradation until fuel contamination is remediated to concentrations below regulatory standards.

The pilot test will be conducted in two phases. The initial phase will consist of construction of a vent well (VW) and vapor monitoring points (MPs), *in situ* respiration testing, and an air permeability test. This initial test phase is expected to take approximately 3 weeks. During the second phase, the bioventing system will be operated and monitored over a 1-year period.

If bioventing proves to be an effective means of remediating soil contamination at this site, pilot test data may be used to design a full-scale remediation system and to estimate the time required for site cleanup. An added benefit of the pilot testing at this site is that a significant amount of the fuel contamination should be biodegraded during the 1-year pilot test, as the testing will take place within highly contaminated soils at the site.

Additional background information on the development and recent success of the bioventing technology is found in the document entitled *Test Plan and Technical Protocol for a Field Treatability Test for Bioventing* (Hincee et al., 1992). This protocol document will serve as the primary reference for pilot test well designs and the detailed procedures to be used during the test.

In addition to the bioventing pilot test at SWMU #70, soil gas sampling will be performed at Facility 187 (Figure 1.1) to determine if contaminated soils are oxygen deficient.

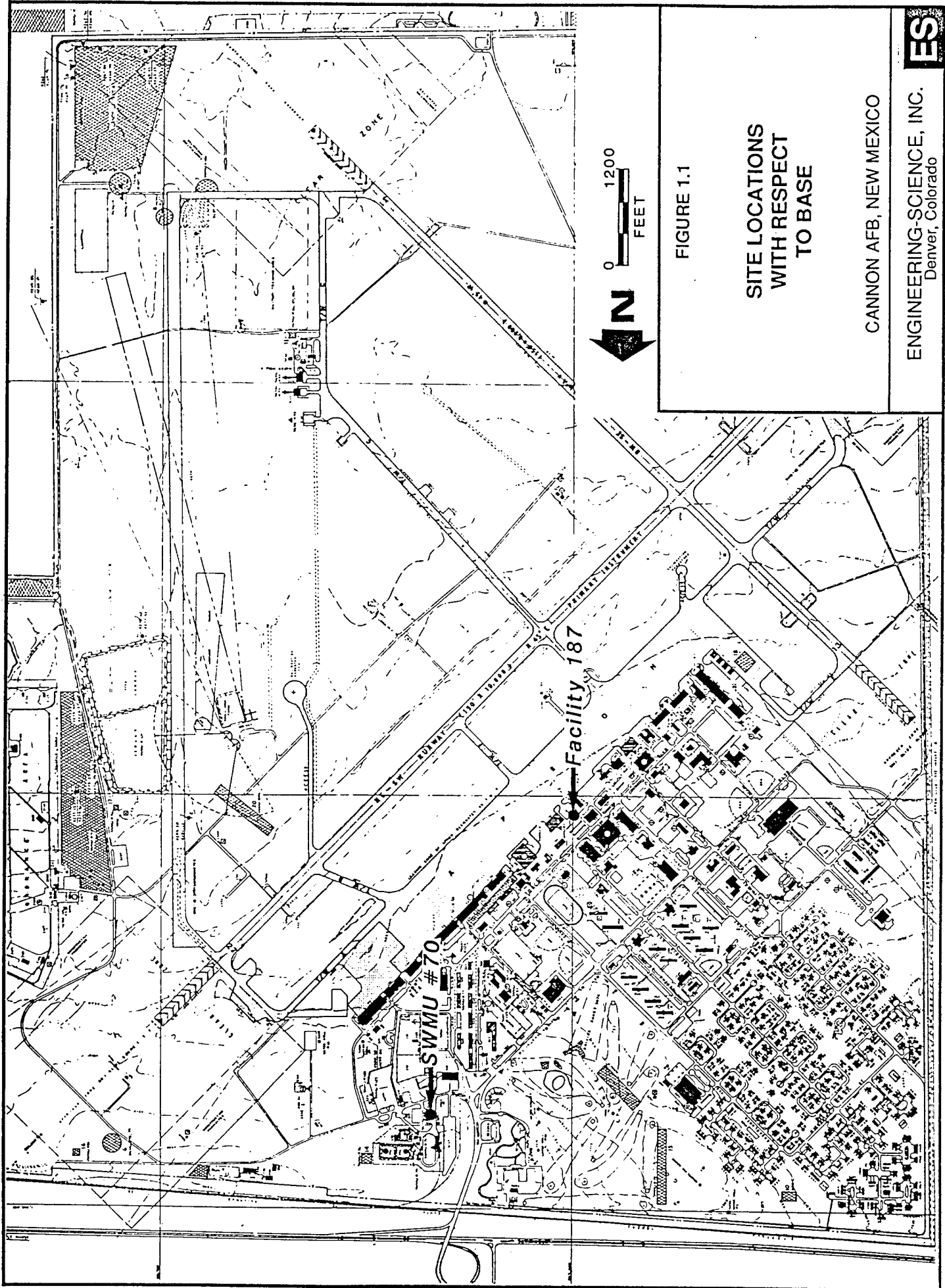

2.0 FACILITY 187

2.1 Site Description

Facility 187 is an operational jet fuel tank that feeds a jet fuel dispenser north of the apron and west of Building 170. During excavation for footings for a new canopy at the dispenser, soil contamination was detected. Soil was excavated to approximately 15 feet below ground surface (bgs) in the vicinity of the dispenser.

Soil near the bottom of the excavation was contaminated to 1580 part per million (ppm) total recoverable petroleum hydrocarbons (TRPH). The source of the contamination beneath the dispenser is unknown. Soils were excavated above and around the tank and contamination in that area was attributed to overfilling the tank. Halon tests indicated the tank was not leaking.

Due to safety, financial, and time constraints, further excavation and tank removal was not performed. Prior to back filling, 6 4-inch Schedule 40 polyvinyl chloride (PVC) perforated pipes were installed around the tank. Additionally, 2 6-inch Schedule 40 PVC perforated pipes were installed at the fuel dispenser. The excavation was backfilled with clean pea gravel.

2.2 Soil Gas Sampling Activities

During the site visit in December 1993, soil gas was sampled from the 6-inch perforated PVC pipes and ambient oxygen concentrations were detected. During pilot testing activities at SWMU #70 additional soil sampling at Facility 187 will be performed. Soil gas samples will be collected from the perforated pipes at both the tank and dispenser locations to determine if soils are oxygen deficient. Additionally, soil gas probes may be driven inside the PVC vent pipes into contaminated soils. This will allow soil gas sampling of contaminated soils beneath the limits of the excavation instead of sampling clean backfill. All soil gas samples will be analyzed with field instruments for oxygen, carbon dioxide, and petroleum hydrocarbons. The results will be available to the base point of contact (POC) following completion, and will be included in the interim bioventing pilot test results report.

3.0 SWMU #70 - OIL/WATER SEPARATOR NO. 326

3.1 Site Description

3.1.1 Site History and Location

SWMU #70 - Oil/Water Separator No. 326 is located in the north part of Cannon AFB, north of Building 326. The location of SWMU #70 with respect to the base is shown in Figure 1.1. The SWMU was used for the recovery of petroleum products generated from wash water effluent from JP-4 fuel truck maintenance operations at Building 326. This effluent contained JP-4 fuel, and petroleum and synthetic lubricating oils. The site proposed for the bioventing pilot study is located in the immediate vicinity of Oil/Water Separator No. 326 (Figure 3.1).

The oil/water separator, active since 1960, is a two-compartment underground unit with a 50-gallon oil/water separator compartment and a detached 220-gallon underground oil storage tank. Recovered petroleum products were directed to the 220-

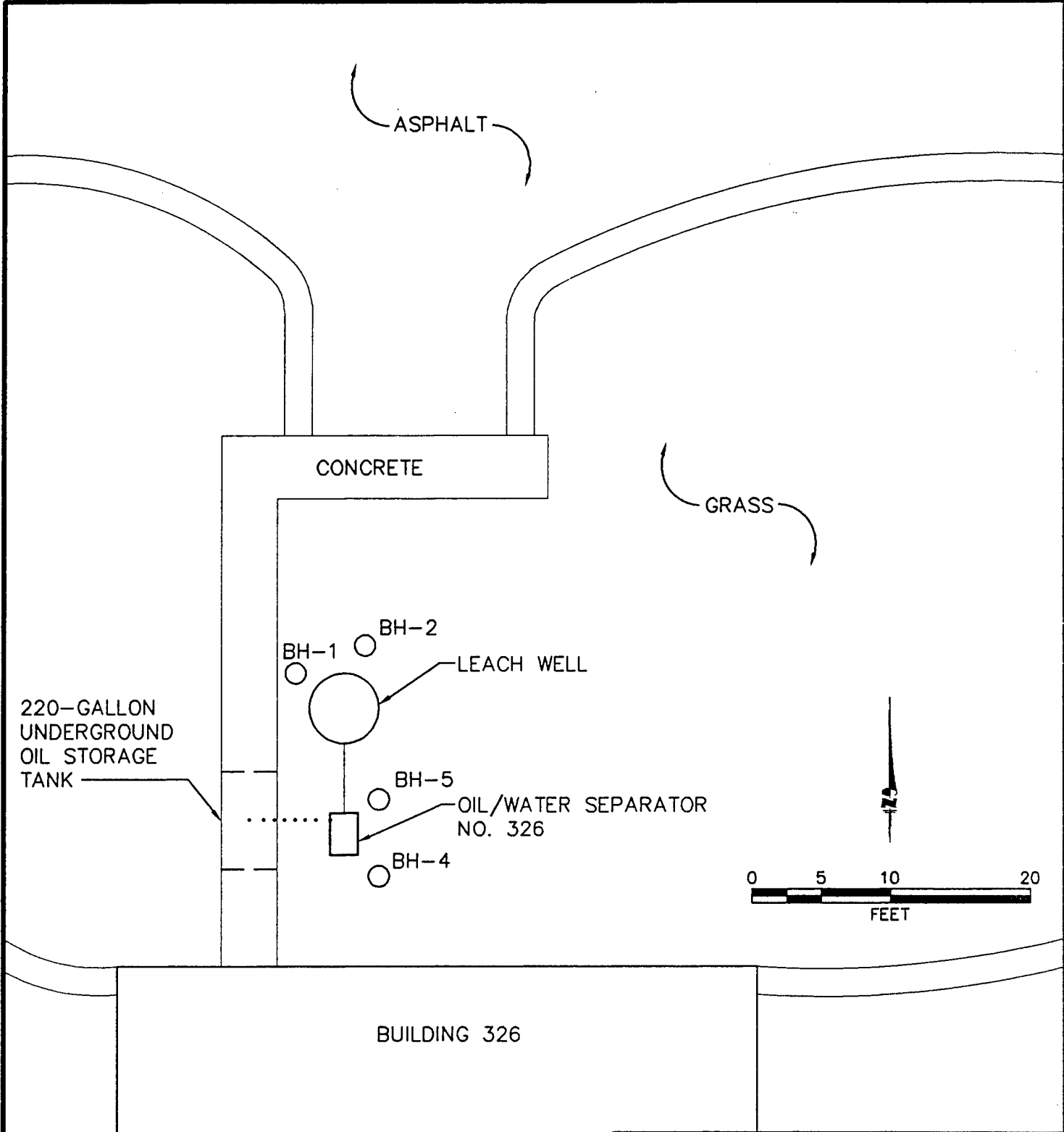

LEGEND

- BH-2 PREVIOUS SOIL BORING
- 2" PIPE

FIGURE 3.1

SITE LAYOUT
SWMU #70

CANNON AFB, NEW MEXICO

ENGINEERING-SCIENCE, INC.

Denver, Colorado

gallon holding tank and the wastewater was discharged into a leach well. The leach well is approximately 5 feet in diameter and 5 feet deep (Figure 3.1). Overflows from the oil/water separator that discharged into the leach well are the suspected source of contamination. The oil/water separator was recently removed from service by plugging the drain line from Building 326.

3.1.2 Site Geology

Because the bioventing technology is applied to unsaturated soils, this section will primarily discuss soils above the deep aquifer. Soils at SWMU #70 consist of clayey silt with sand lenses to approximately 38 feet below ground surface (bgs), and very stiff calcareous silty sand from approximately 38 to approximately 60 feet bgs. Soils from approximately 60 to 320 feet bgs consist of sand, sandstone, and silt of the Ogallala Formation. Groundwater is encountered at a depth of approximately 270 feet bgs and generally flows southeastward.

3.1.3 Site Contaminants

The primary soil contaminants at this site are fuel-related petroleum hydrocarbons which have been detected in the soils at depths ranging from 0 to 60 feet bgs. Soil sampling at this site has been conducted to a depth of only 58.5 feet bgs, and therefore the vertical extent of hydrocarbon contamination has not been defined. Total petroleum hydrocarbons (TPH) were detected at 19,200 milligrams per kilogram (mg/kg) in soil boring BH-2 at a depth of 4 to 6 feet bgs (Figure 3.1). In BH-1 at a depth of 58 feet bgs, TPH were detected at 5,710 mg/kg. Total benzene, toluene, ethylbenzene, and xylenes (BTEX) were detected in samples collected from the soil borings at concentrations ranging from nondetect to 1,815 mg/kg (Woodward-Clyde Consultants, 1993).

3.2 Pilot Test Activities

The purpose of this section is to describe the pilot test activities to take place at SWMU #70. The proposed locations and construction details for the central VW and vapor MPs are discussed. The blower configuration that will be used to inject air (oxygen) into contaminated soils is also discussed in this section. Finally, a brief description of the pilot test procedures is provided.

The bioventing technology is intended to remediate contamination only in the unsaturated zone. Therefore, pilot test activities will be confined mainly to unsaturated soils. Because site investigation information is limited, the central VW and MPs will be completed to a depth to be determined in the field based on visual observations and soil sample headspace readings. The VW will be completed to a depth corresponding to the assumed extent of contamination so that oxygen will be provided to the deepest levels of contamination. If ground water is encountered, the VW will be completed approximately 5 feet into the ground water to allow for seasonal water level fluctuations. No dewatering will take place during the pilot test.

Existing monitoring wells will not be used as primary air injection or vapor MPs. However, monitoring wells which have a portion of their screened interval above the water table may be used to measure the composition of background soil gas.

3.2.1 Layout of Pilot Test Components

A general description of criteria for siting a central VW and vapor MPs is included in the protocol document (Hinchee et al., 1992). Figure 3.2 illustrates the proposed locations of the central VW and MPs at this site. The final locations of these wells may vary slightly from the proposed locations if significant fuel contamination is not observed in the boring for the central VW. Based on previous site investigation data and a site visit, the VW should be located approximately 20 feet north of Building 326, near the northwest side of the leach well. Soils in this area are expected to be TPH contaminated and oxygen depleted (< 2%), and biological activity should be stimulated by oxygen-rich soil gas ventilation during pilot test operations.

Due to the extensive depth of contamination at this site, the potential for moderately-permeable soils, and the experience ES has had with similar soil types, the potential radius of venting influence around the central VW is expected to be 30 to 40 feet. Three vapor MPs (MPA, MPB, and MPC) will be located within a 35-foot radius of the central VW (Figure 3.2).

3.2.2 Vent Well

The VW will be constructed of 4-inch-diameter Schedule 40 polyvinyl chloride (PVC), with 0.04-inch slotted screen set from 8 feet bgs to a depth to be determined in the field. Flush-threaded PVC casing and screen with no organic solvents or glues will be used. The filter pack will be clean, well-rounded silica sand with a 6-9 grain size, and will be placed in the annular space to 1 foot above the screened interval. A 5-foot-thick bentonite seal will be placed directly over the filter pack to produce an air-tight seal above the screened interval. The bentonite seal, consisting of granular bentonite, will be placed in 6-inch layers, with each layer hydrated in place with potable water prior to the addition of subsequent layers. The remaining annular space will then be filled to 1 foot bgs with a bentonite/cement grout. A complete seal is critical to prevent injected air from short-circuiting to the surface during the bioventing test. The VW will be completed in a 12-inch flush-mount water-tight well box. Figure 3.3 illustrates the proposed central VW construction detail for this site.

3.2.3 Monitoring Points

A typical multidepth vapor MP installation for this site is shown in Figure 3.4. Soil gas oxygen and carbon dioxide concentrations will be monitored at up to five depths. The final depths of the screens may vary slightly from the proposed depths if significant fuel contamination is not observed at the specified interval. The vapor probes (screens) may be placed such that one probe will monitor each of the following layers: friable soils (5-foot depth); shallow loose caliche soils (25-foot depth); deeper very firm caliche soils (50-foot depth); and two probes in the deeper sand, sandstone, and silt materials. Soil temperature will be monitored using thermocouples installed at the upper and lower point at MPA. Multidepth monitoring will confirm that the entire soil profile is receiving oxygen and will be used to measure fuel biodegradation rates at all depths.

Each MP will be constructed with up to five vapor probes placed within sand intervals, separated by bentonite seals. Vapor probes, constructed of 6-inch-long

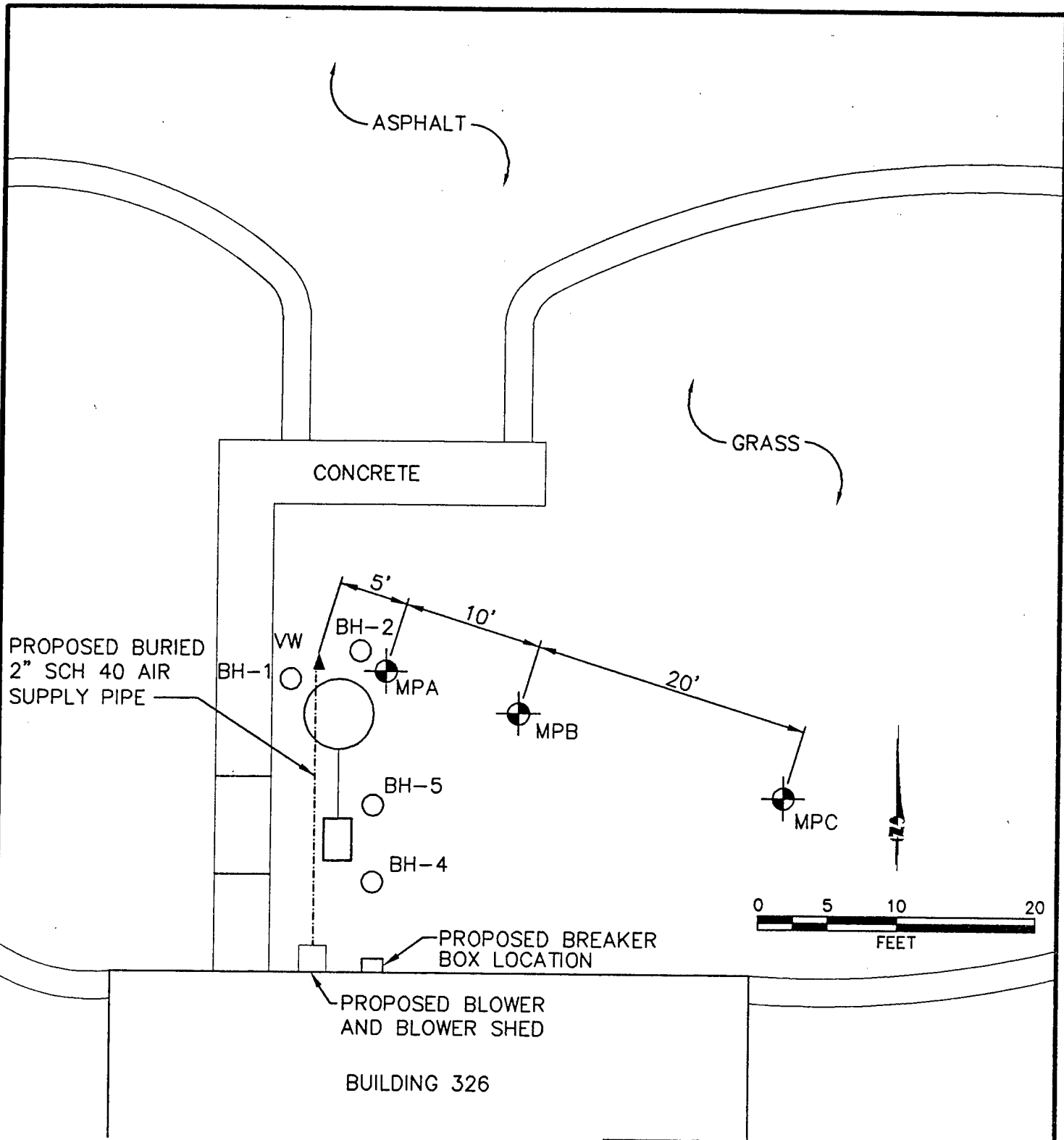

FIGURE 3.2
PROPOSED VENT WELL,
MONITORING POINT, AND
BLOWER LOCATIONS
SWMU #70

CANNON AFB, NEW MEXICO

ENGINEERING-SCIENCE, INC.

Denver, Colorado

- LEGEND**
- BH-2 ○ PREVIOUS SOIL BORING
 - MPC ⊕ MONITORING POINT
 - VW ▲ VENT WELL

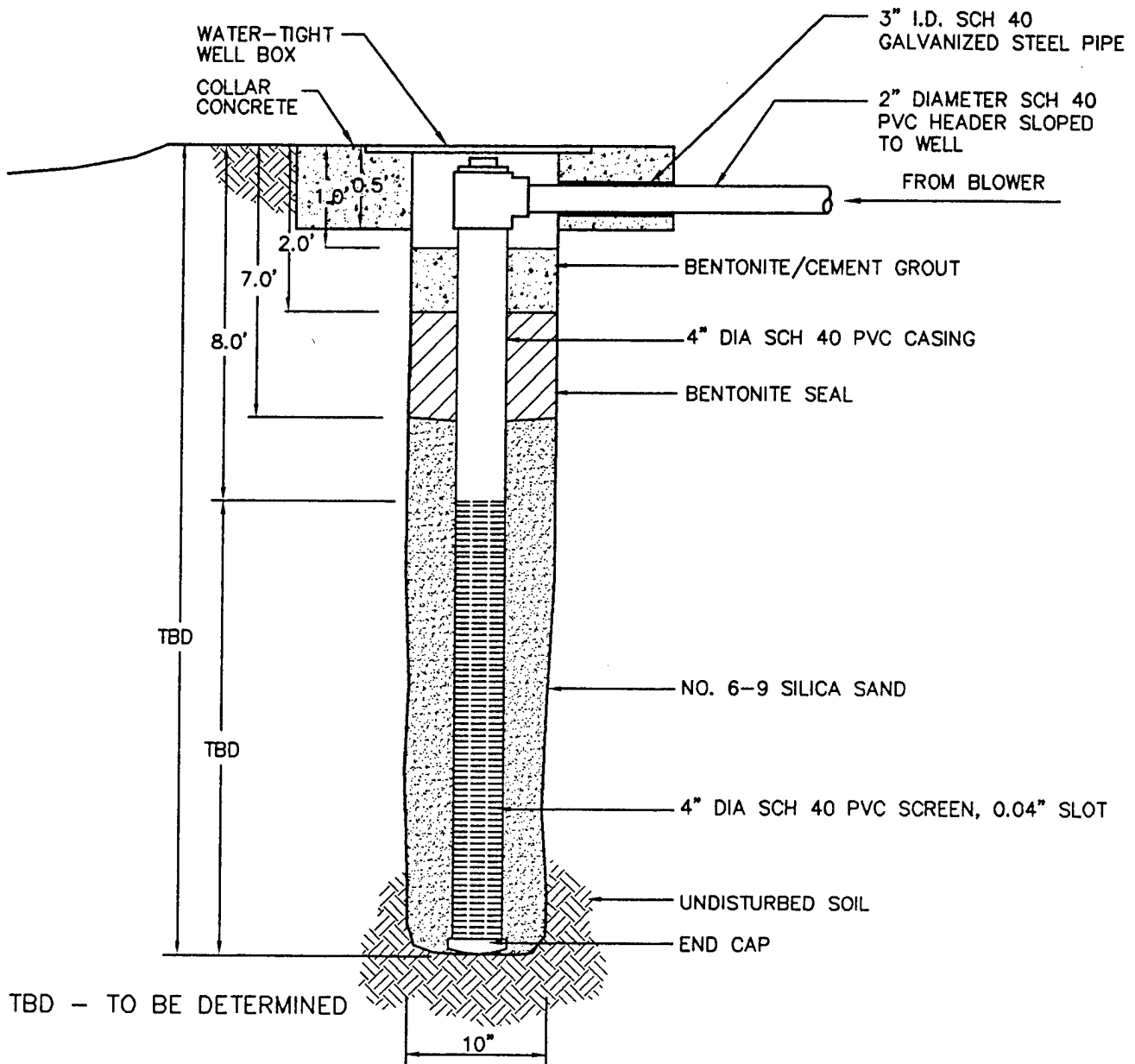

NOT TO SCALE

FIGURE 3.3
PROPOSED INJECTION VENT
WELL CONSTRUCTION DETAIL
SWMU #70

CANNON AFB, NEW MEXICO

ENGINEERING-SCIENCE, INC.

Denver, Colorado

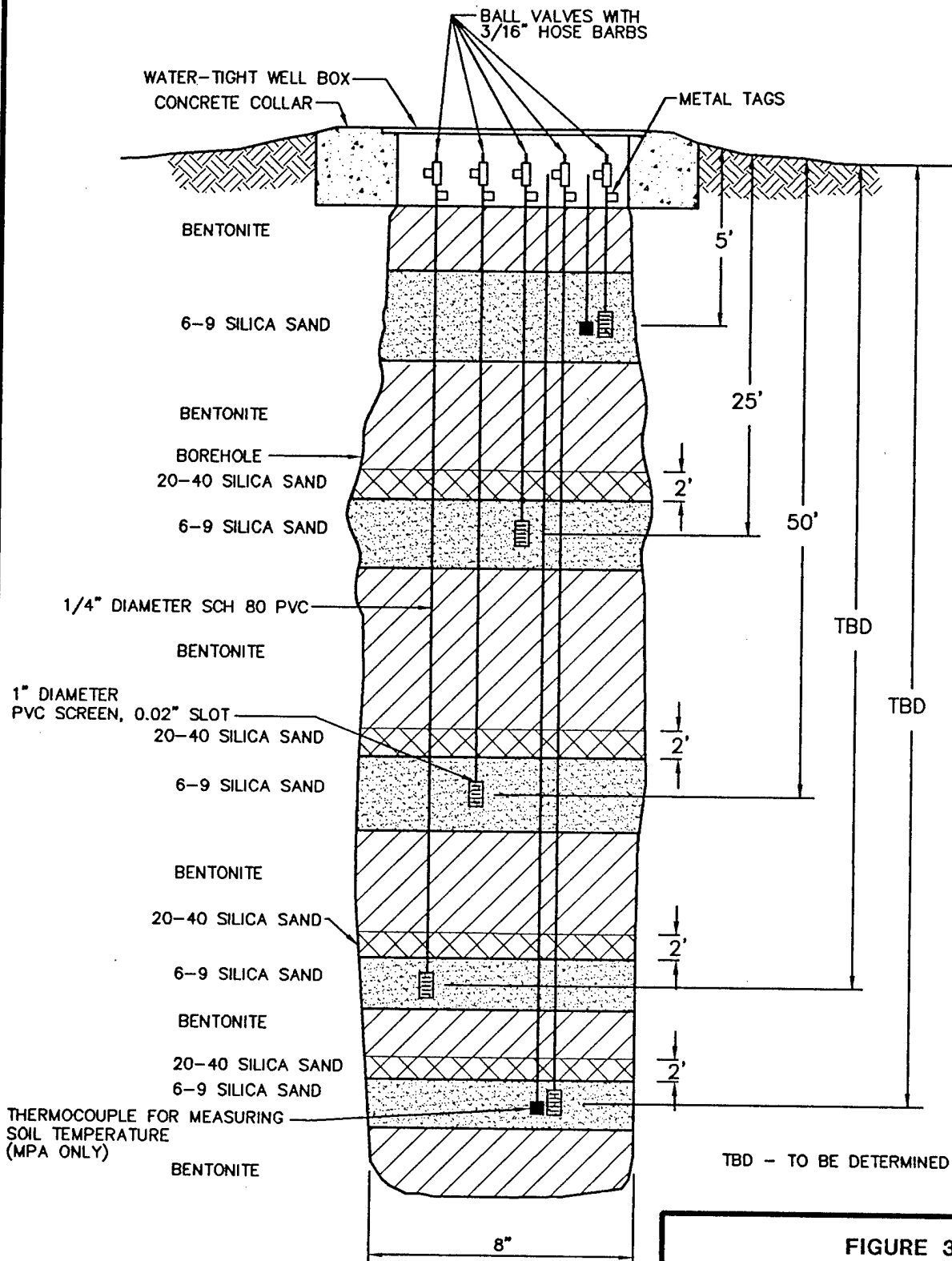

FIGURE 3.4
 PROPOSED MONITORING POINT
 CONSTRUCTION DETAIL
 SWMU #70
 CANNON AFB, NEW MEXICO
ENGINEERING-SCIENCE, INC.
 Denver, Colorado

sections of 1-inch-diameter, 0.02-inch-slotted PVC well screen, will be placed within a 2-foot layer of 6-9 silica sand and 0.25-inch Schedule 80 PVC will extend to the surface. A 2-foot layer of 20-40 silica sand will be placed above the 6-9 silica sand for all probes except at the 5-foot interval to ensure bentonite does not foul the probes. The annular spaces between the five screened MP intervals will be sealed with bentonite to isolate the monitoring intervals. The bentonite seals will consist of granular bentonite hydrated in place. The bentonite within 2 feet above and below the sand intervals will be placed in approximately 6-inch layers and hydrated with potable water prior to placement of subsequent layers to assure complete saturation and hydration of the bentonite. The top of each 0.25-inch PVC riser from the probes will be completed with a 0.25-inch ball valve. The ball valve assemblies and thermocouple plugs will be protected within a 12-inch flush-mount, water-tight well box set in concrete. Additional details on VW and MP construction are presented in Section 4 of the protocol document (Hinchee et al., 1992).

3.2.4 Blower System

A 3-horsepower positive-displacement blower capable of injecting air over a wide range of flow rates and pressures will be used to conduct the initial air permeability test. Figure 3.5 is a schematic of a typical air injection system used for pilot testing. The maximum power requirement anticipated for this pilot test is 230-volt, single-phase, 30-amp service. Additional details on power supply requirements are described in Section 8.0, Base Support Requirements.

3.2.5 Air Permeability Test

The objective of the air permeability test is to determine the extent of the subsurface that can be oxygenated using one VW. Prior to initiating the test, baseline concentrations of oxygen, carbon dioxide, and total volatile hydrocarbons (TVH) will be measured in soil gas from the VW and each MP screened interval.

Air will be injected into the VW using the blower unit, and pressure response will be measured at each MP with differential pressure gauges to determine the region influenced by the unit. Oxygen will also be monitored in the MPs to ascertain whether oxygen levels in the soil increase as the result of air injection. One air permeability test lasting 4 to 24 hours will be performed at this site.

3.2.6 *In Situ* Respiration Test

The objective of the *in situ* respiration test is to determine the rate at which soil bacteria degrade petroleum hydrocarbons. Respiration tests will be performed at every vapor MP where bacterial biodegradation of hydrocarbons is indicated by low initial oxygen levels and elevated carbon dioxide concentrations in the soil gas. Using 1-standard-cubic-foot-per-minute (scfm) pumps, air will be injected into approximately four MP depth intervals containing low levels (<2%) of oxygen. A 20-hour air injection period will be used to oxygenate local contaminated soils. At the end of the 20-hour injection period, the air supply will be cut off, and oxygen, carbon dioxide, and TVH concentrations will be monitored for the following 48 to 72 hours. The decline in oxygen and increase in carbon dioxide concentrations over time will be used to estimate rates of bacterial degradation of fuel residuals. Helium will also be injected

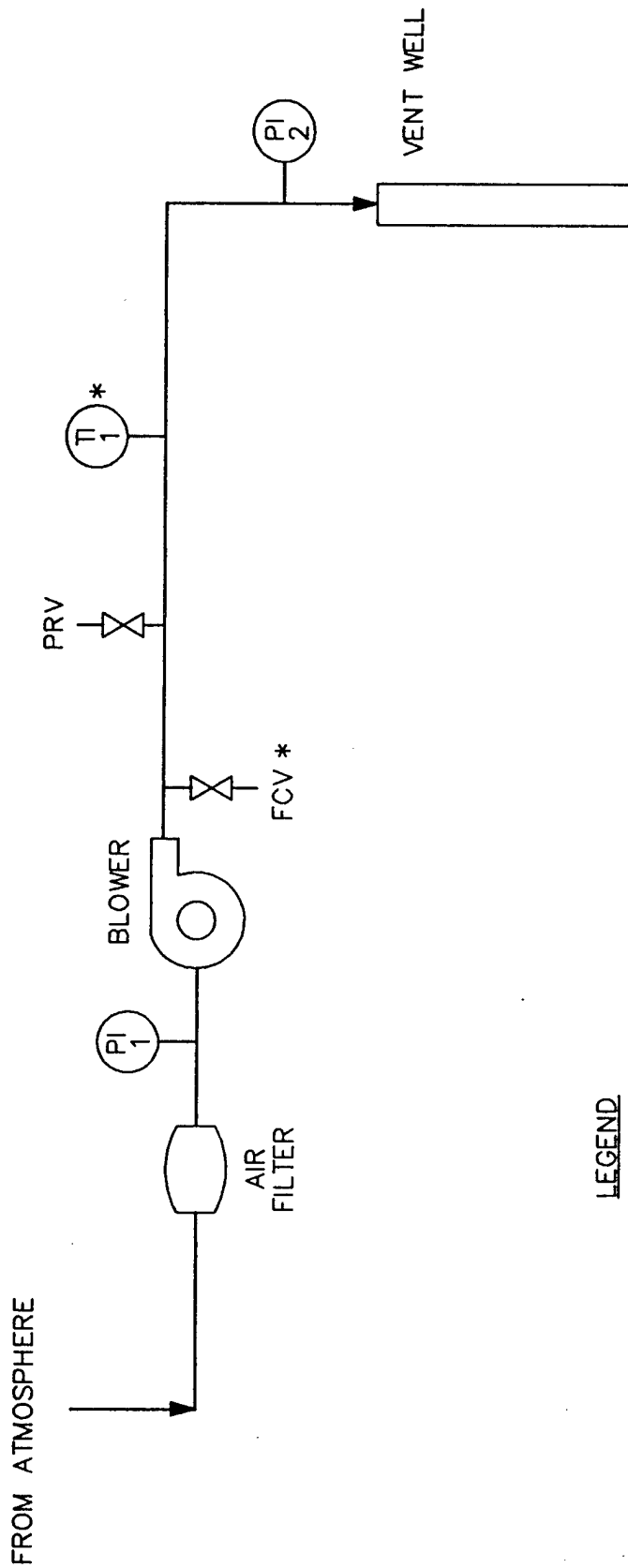

LEGEND

- PI 1 PRESSURE INDICATOR
- TI 1 TEMPERATURE INDICATOR
- FCV FLOW CONTROL VALVE
- PRV PRESSURE RELIEF VALVE
- * OPTIONAL

FIGURE 3.5
TYPICAL BLOWER SYSTEM
INSTRUMENTATION DIAGRAM
FOR AIR INJECTION
SWMU #70

CANNON AFB, NEW MEXICO
ENGINEERING-SCIENCE, INC.
 Denver, Colorado

into the selected MP intervals to determine the effectiveness of the bentonite seals. Additional details on the *in situ* respiration test procedures are provided in Section 5.7 of the protocol document (Hinchee et al., 1992).

3.2.7 Extended Pilot Test Bioventing System

An extended, 1-year bioventing system also will be installed at SWMU #70. The system will be chosen based upon the results of the initial respiration and air permeability tests. However, it is anticipated that the extended test blower will be capable of flow rate in the range of 50-70 scfm and will not exceed 2.5 horsepower. A base electrician will be requested to wire the blower to line power. The blower will be housed in a small, prefabricated shed to provide protection from the weather.

The system will be in operation for 1 year, and every 6 months ES personnel will conduct an *in situ* respiration test to monitor the long-term performance of this bioventing system. Weekly system checks will be performed by Cannon AFB personnel. If required, major maintenance of the blower unit will be performed by ES personnel. Detailed blower system information and a maintenance schedule will be included in the operation and maintenance (O&M) manual to be provided to the base. More detailed information regarding the test procedures can be found in the protocol document.

4.0 BACKGROUND MONITORING POINT

The construction of an additional vapor MP may be required to measure background levels of oxygen and carbon dioxide and to determine if natural carbon sources are contributing to oxygen uptake during the *in situ* respiration test. This background MP would be installed in an area of uncontaminated soil and in the same or similar stratigraphic formations as the MPs to be installed. The background well would be similar in construction to the MPs (Figure 3.4), and would be screened at two or more depths. ES will require some assistance from Cannon AFB in selecting an appropriate location for the proposed background MP within 200 feet of a 110-volt power source.

Existing groundwater monitoring wells located in areas with no fuel contamination may be suitable for use as background MPs. These wells must have a portion of their screened interval above the water table, and initial soil gas samples must contain oxygen in excess of 15 percent to be used as background MPs. Additional information regarding background MPs may be found in Section 4.3 of the protocol document (Hinchee et al., 1992).

5.0 SOIL AND SOIL GAS SAMPLING

5.1 Soil Samples

Four soil samples will be collected from the pilot test area during the installation of the VW and MPs. Sampling procedures will follow those outlined in the protocol document. One sample will be collected from the most contaminated interval of the VW boring, and one sample will be collected from the interval of highest apparent contamination in each of the borings for the three MPs. A total hydrocarbon vapor analyzer will be used during augering to screen split-spoon soil samples for intervals of high fuel contamination. Soil samples will be analyzed for total recoverable petroleum

hydrocarbons (TRPH), BTEX, soil moisture, pH, particle sizing, alkalinity, total iron, and nutrients.

Soil samples for laboratory analysis will be collected using a split-spoon sampler containing brass tube liners. Soil samples collected in the brass tubes will be immediately trimmed, and the ends will be sealed with Teflon® fabric held in place by plastic caps. Soil samples will be labelled following the nomenclature specified in the protocol document (Section 5), wrapped in plastic, and placed in a cooler maintained at a temperature of 4 degrees centigrade for shipment. A chain-of-custody form will be filled out, and the cooler will be shipped to the PACE, Inc. laboratory in Huntington Beach, California for analysis. This laboratory has been audited by the Air Force and meets all quality assurance/quality control and certification requirements for the State of California.

5.2 Soil Gas Samples

Initial and final soil gas samples will be collected in 1-liter SUMMA® canisters in accordance with the Bioventing Field Sampling Plan (Engineering-Science, Inc., 1992) from the VW and from the MPs closest to and furthest from the VW. Additionally, these soil gas samples will be used to predict potential air emissions, to determine the reduction in BTEX and TVH during the 1-year test, and to detect any migration of these vapors from the source area.

Soil gas sample canisters will be placed in a small cooler and packed with foam pellets to prevent excessive movement during shipment. Samples will not be sent on ice to prevent condensation of hydrocarbons. A chain-of-custody form will be filled out, and the cooler will be shipped to the Air Toxics, Inc. laboratory in Folsom, California for analysis.

6.0 HANDLING OF DRILL CUTTINGS

Drill cuttings from all VW and MP borings will be collected in U.S. Department of Transportation (DOT) approved containers. The containers will be labeled and placed in the Cannon AFB hazardous materials storage area. These drill cuttings will become the responsibility of Cannon AFB, and will be analyzed, handled, and disposed of in accordance with the current procedures for ongoing remedial investigations. This project could generate up to 90 55-gallon drums of cuttings.

7.0 EXCEPTIONS TO PROTOCOL PROCEDURES

The procedures that will be used to measure the air permeability of the soil and *in situ* respiration rates are described in Sections 4 and 5 of the protocol document (Hinchee et al., 1992). No exceptions to the protocol procedures are anticipated.

8.0 BASE SUPPORT REQUIREMENTS

The following base support is needed prior to the arrival of the drilling subcontractor and the ES pilot test team:

- Assistance in obtaining drilling and digging permits.

- Assistance in selecting a suitable location for the background MP. The background well location should be in an area with no fuel contamination and with similar stratigraphy to that of the bioventing pilot test sites. Preferably, 110-volt receptacle power will be available within 200 feet of the background MP location.
- Installation of a new power distribution panel or breaker box at Building 326 near the sidewalk (Figure 3.2). This location will require explosion-proof wiring and receptacles. The panel should include 230-volt, 30-amp, single-phase service with one 230-volt receptacle and two 115-volt receptacles.
- Provision of any paperwork required to obtain gate passes and security badges for approximately two ES employees and three drillers. Vehicle passes will be needed for one ES truck and trailer, and for the drill rig and service truck.

During the initial testing, the following base support is needed:

- Parking space for one 8- x 20-foot laboratory and equipment trailer located as close to each pilot test area as practical.
- A decontamination pad or other designated area where the driller can clean augers between borings.
- Acceptance of responsibility by Cannon AFB for drill cuttings from VW and MP borings, including additional sampling, to determine disposal options. ES will provide the results of TRPH and BTEX soil analysis to help characterize drill cuttings.
- Twelve square feet of desk space and a telephone in a building located as close to the sites as practicable.
- The use of a facsimile machine for transmitting 15 to 20 pages of test results.

During the 1-year extended pilot test, base personnel will be required to perform the following activities:

- Check the blower system once per week to ensure that it is operating and to record the air-injection pressure and temperature. Change air filters and blower lubricants when required. ES will provide a brief training session on these procedures and an O&M manual.
- If the blower stops working, notify Mr. Brian Blicher, Mr. John Hall, or Mr. Doug Downey, ES-Denver, at (303) 831-8100, or Mr. Patrick Haas, Air Force Center for Environmental Excellence (AFCEE), at (210) 536-4314.
- Arrange site access for an ES technician to conduct *in situ* respiration tests approximately 6 months and 1 year after the initial pilot tests, and for any blower system repairs or modifications.

9.0 PROJECT SCHEDULE

The following schedule is contingent upon timely approval of this pilot test work plan.

<u>Event</u>	<u>Date</u>
Draft Pilot Test Work Plan to AFCEE/Cannon AFB	12 January 1994
Begin Initial Pilot Test	7 February 1994
Complete Initial Pilot Test	25 February 1994
Interim Results Report	1 April 1994
6-Month Respiration Test	August 1994
Final Respiration Test	February 1995

10.0 POINTS OF CONTACT

Mr. John Ekhoﬀ
 27 Civil Engineering Squadron
 Cannon AFB, NM 88103-5136
 DSN 681-4639 or 2739
 COM (505) 784-4639

Mr. Patrick Haas
 AFCEE/EST
 Brooks AFB, TX 78235-5000
 DSN 240-4314
 COM (210) 536-4314

Mr. Doug Downey
 Engineering-Science, Inc.
 1700 Broadway, Suite 900
 Denver, CO. 80290
 (303) 831-8100
 Fax (303) 831-8208

11.0 REFERENCES

- Engineering-Science, Inc. 1992. *Field Sampling Plan for AFCEE Bioventing*. January.
- Hinchee, R.E., S.K. Ong, R.N. Miller, D.C. Downey, and R. Frandt. 1992. *Test Plan and Technical Protocol for a Field Treatability Test for Bioventing*. January.
- Woodward-Clyde Consultants. 1993. *RCRA Facility Investigation, Appendix 3 SWMUs, Phase 1, Cannon Air Force Base, New Mexico*. November

PART II
DRAFT
INTERIM PILOT TEST RESULTS REPORT FOR
SWMU #70
OIL/WATER SEPARATOR NO. 326
CANNON AFB, NEW MEXICO

Prepared for:

Air Force Center for Environmental Excellence
Brooks AFB, Texas

and

27 CES/CEV
Cannon AFB, New Mexico

Prepared by:

Engineering-Science, Inc.
1700 Broadway, Suite 900
Denver, Colorado 80290

August 1994

TABLE OF CONTENTS

	<u>Page</u>
1.0 PILOT TEST design and construction.....	II-1
1.1 Air Injection Vent Well.....	II-2
1.2 Monitoring Points.....	II-2
1.3 Blower Unit.....	II-2
2.0 PILOT TEST SOIL & SOIL GAS SAMPLING RESULTS	II-8
2.1 Soil Sampling.....	II-8
2.1.1 Soil Sampling Methods & Rationale	II-8
2.1.2 Site Geology	II-9
2.1.3 Soil Sampling Results	II-11
2.2 Soil Gas Sampling Results.....	II-15
2.3 Exceptions to Test Protocol Document Procedures	II-15
3.0 PILOT TEST RESULTS	II-19
3.1 Initial Soil Gas Chemistry	II-19
3.2 Air Permeability	II-19
3.3 Oxygen Influence	II-22
3.4 In Situ Respiration Rates	II-22
3.5 Potential Air Emissions	II-30
4.0 FACILITY 187	II-30
5.0 RECOMMENDATIONS	II-30
6.0 REFERENCES	II-31
APPENDIX A	
Soil Sampling Letter Addendum to the Work Plan	
APPENDIX B	
Geologic Boring Logs	
APPENDIX C	
O&M Checklist	
APPENDIX D	
Chain-of-Custody Forms	
APPENDIX E	
Test Data and Calculations	

TABLE OF CONTENTS (Continued)

LIST OF FIGURES

<u>No.</u>	<u>Title</u>	<u>Page</u>
1.1	As Built Vent Well, Monitoring Point, and Blower Locations.....	II-3
1.2	As Built Injection Vent Well Construction Detail	II-4
1.3	Typical As Built Monitoring Point Construction Detail	II-5
1.4	As Built Background Monitoring Point Construction Detail	II-6
1.5	As Built Extended Pilot Test Blower System Instrumentation Diagram for Air Injection.....	II-7
2.1	Geologic Cross Section A-A'	II-10
3.1	Respiration Test CA1-SWMU 70, CA1-MPA-5	II-24
3.2	Respiration Test CA1-SWMU 70, CA1-MPA-25	II-25
3.3	Respiration Test CA1-SWMU 70, CA1-MPA-50	II-26
3.4	Respiration Test CA1-SWMU 70, CA1-MPB-70.....	II-27
3.5	Respiration Test CA1-SWMU 70, CA1-MPB-50.....	II-28

LIST OF TABLES

<u>No.</u>	<u>Title</u>	<u>Page</u>
2.1	Soil TRPH & BTEX Analytical Results	II-12
2.2	Field QA/QC Analytical Results	II-14
2.3	Soil Semivolatile Analytical Results.....	II-16
2.4	Soil Inorganics and Physical Parameter Analytical Results	II-17
2.5	Soil Gas Analytical Results	II-18
3.1	Initial Soil Gas Chemistry	II-20
3.2	Maximum Pressure Response - Air Permeability Test.....	II-21
3.3	Influence of Air Injection at Vent Well on Monitoring Point Oxygen Levels.....	II-23
3.4	Oxygen Utilization Rates	II-29

PART II
DRAFT
INTERIM PILOT TEST RESULTS REPORT FOR
SWMU #70 - OIL/WATER SEPARATOR NO. 326
CANNON AFB, NEW MEXICO

Initial bioventing pilot tests for *in situ* treatment of fuel-contaminated soils at Solid Waste Management Unit (SWMU) #70 at Cannon Air Force Base (AFB) (the base), New Mexico were completed by Engineering-Science, Inc. (ES) during the period from May 2 through May 16, 1994. The three primary objectives of the pilot tests are:

- To assess the potential for supplying oxygen throughout the contaminated soil interval;
- To determine the rate at which indigenous microorganisms will degrade fuel when supplied with oxygen-rich soil gas, and
- To evaluate the potential for sustaining these rates of biodegradation until fuel contamination is remediated to concentrations below regulatory standards.

At the request of the US Environmental Protection Agency (EPA) Region VI office, an additional objective for the Cannon AFB investigation was to evaluate the vertical extent of petroleum contamination which had not been fully defined during the previous investigation of SWMU #70. The purpose of this report is to describe the results of the initial pilot tests at SWMU #70 and to make specific recommendations for extended testing to determine the long-term impact of bioventing on site contaminants. Descriptions of the history, geology, and contamination at the sites are contained in Part I, the Bioventing Pilot Test Work Plan. A letter addendum to the Work Plan detailed soil sampling and analysis activities that were performed at the site (Appendix A). Further detail of site geology and contaminant distribution as delineated during installation of the bioventing system is provided in Section 2 of this report. Additionally, this report details soil gas sampling activities that were performed at Facility 187 to determine if this site is a potential candidate for bioventing.

1.0 PILOT TEST DESIGN AND CONSTRUCTION

Installation of three vapor monitoring points (MPs) and one vent well (VW) at SWMU #70 took place on May 3 through May 11, 1994. Drilling oversight, MP installation, and soil sampling was conducted by Mr. Brian Blicher, ES site manager, and Mr. Dave Moutoux, ES

test engineer. Drilling services were provided by Beylik Drilling Inc. of Bernallilo, New Mexico, and electrical services were provided by Chaparral Electric of Portales, New Mexico. The following sections describe the final design and installation of the bioventing system.

Three MPs, one VW, and a blower unit were installed at the SWMU #70 site. Locations of the VW and MPs completed at the site are shown in Figure 1.1. Boring logs for the MPs and VW are included in Appendix B. The background MP for this site was installed south of the site in an open area approximately 20 feet to the north of the fenceline to Facility 210, the Morale, Welfare, and Recreation recreational vehicle parking area, west of Warehouse 211 and east of Building 216, the petroleum, oil, and lubricant (POL) administration offices.

1.1 Air Injection Vent Well

The air injection VW was installed following procedures described in the Air Force Center for Environmental Excellence (AFCEE) bioventing protocol document (Hinchee et al., 1992). Figure 1.2 shows construction details for the VW. The VW was installed in contaminated soils with the screened interval extending from 10 to 110 feet below ground surface (bgs). Groundwater was not encountered. The VW was constructed using 4-inch-diameter, Schedule 40 polyvinyl chloride (PVC) casing, with 100 feet of 0.04-inch slotted PVC screen. The annular space between the well casing and borehole was filled with 8-12 grain-size silica sand from the bottom of the borehole to 1.25 feet above the well screen. Approximately 8 feet of granular bentonite were placed above the sand in 6-inch lifts and hydrated in place. The VW was completed with a PVC tee set approximately 1 foot bgs. The tee was then covered with a well box set at the ground surface.

1.2 Monitoring Points

MP screens were installed at 5, 25, 50, 70, and 110 feet bgs. The three MPs (MPA, MPB, and MPC) at this site were constructed as shown in Figure 1.3. MPA, MPB, and MPC were installed approximately 9, 19, and 34 feet from the VW, respectively (Figure 1.1). The 25-, 50-, 70-, and 110-foot-deep intervals were constructed using 12-inch long sections of 1-inch-diameter PVC well screen with 0.50-inch PVC riser pipes extending to the ground surface. The 5-foot bgs intervals were constructed similarly with 6-inch-long sections of 1-inch-diameter PVC well screen. At the top of each riser, a ball valve and a 3/16-inch hose barb were installed. The top of each MP was completed with a flush-mounted metal well protector set in concrete. A thermocouple was installed at the 5- and 110-foot depths at MPA to measure soil temperature variations. The background MP was completed to 50 feet bgs, and three MP intervals were installed as shown in Figure 1.4.

1.3 Blower Unit

A 1-horsepower Gast® regenerative blower was installed at SWMU 70 for the extended pilot test (2.5- and 1-horsepower Gast® regenerative blowers were used for initial testing.) The blower is energized by 230-volt, single-phase, 30-amp power from a breaker box. The blower was configured to inject approximately 15 standard cubic feet per minute (scfm) for the extended pilot test. The low air injection flow rate was chosen to minimize drying effects and migration of volatile hydrocarbons through the soil while supplying oxygen throughout the contaminated soils. The configuration and instrumentation for the extended pilot test blower unit are shown on Figure 1.5. Prior to departing from the site, ES engineers provided

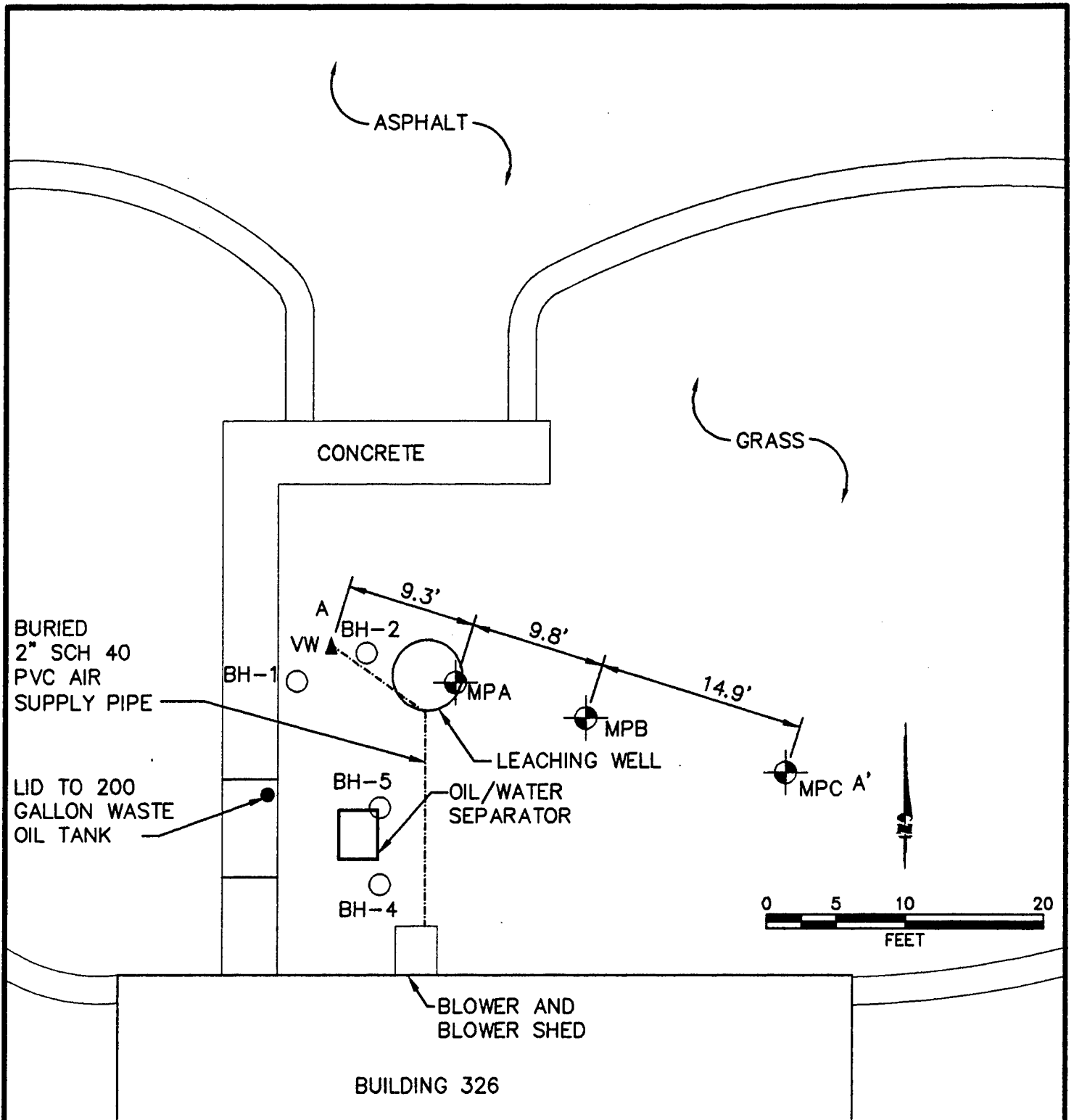



- LEGEND**
-  BH-2 PREVIOUS SOIL BORING
 -  MPC MONITORING POINT
 -  VW VENT WELL

FIGURE 1.1

**AS-BUILT VENT WELL,
MONITORING POINT, AND
BLOWER LOCATIONS
SWMU #70**

CANNON AFB, NEW MEXICO

ENGINEERING-SCIENCE, INC.

Denver, Colorado

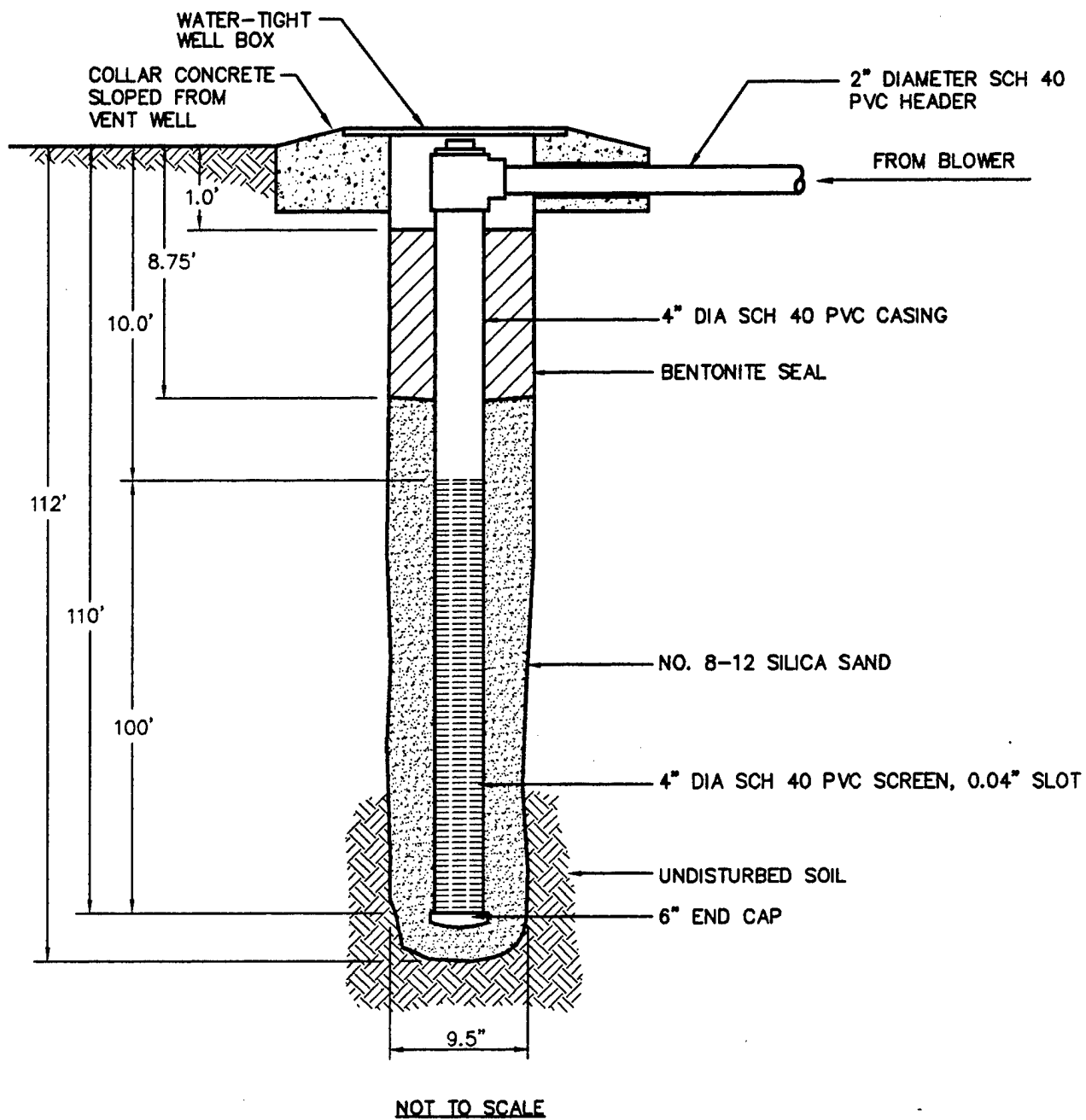
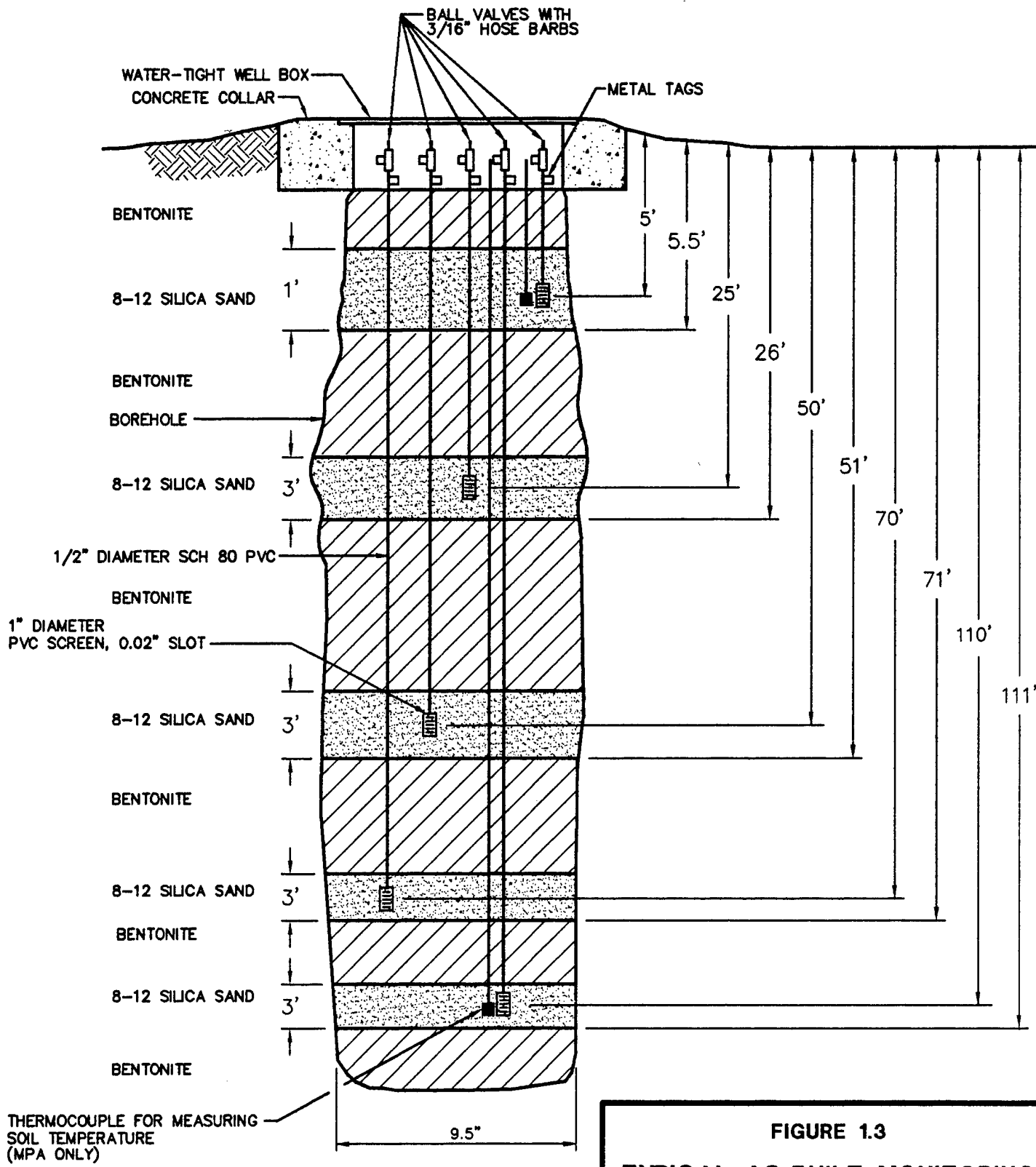

FIGURE 1.2
 AS-BUILT INJECTION VENT
 WELL CONSTRUCTION DETAIL
 SWMU #70

CANNON AFB, NEW MEXICO

ENGINEERING-SCIENCE, INC.

Denver, Colorado



NOT TO SCALE

FIGURE 1.3
TYPICAL AS-BUILT MONITORING POINT CONSTRUCTION DETAIL
SWMU #70

CANNON AFB, NEW MEXICO

ENGINEERING-SCIENCE, INC.
 Denver, Colorado

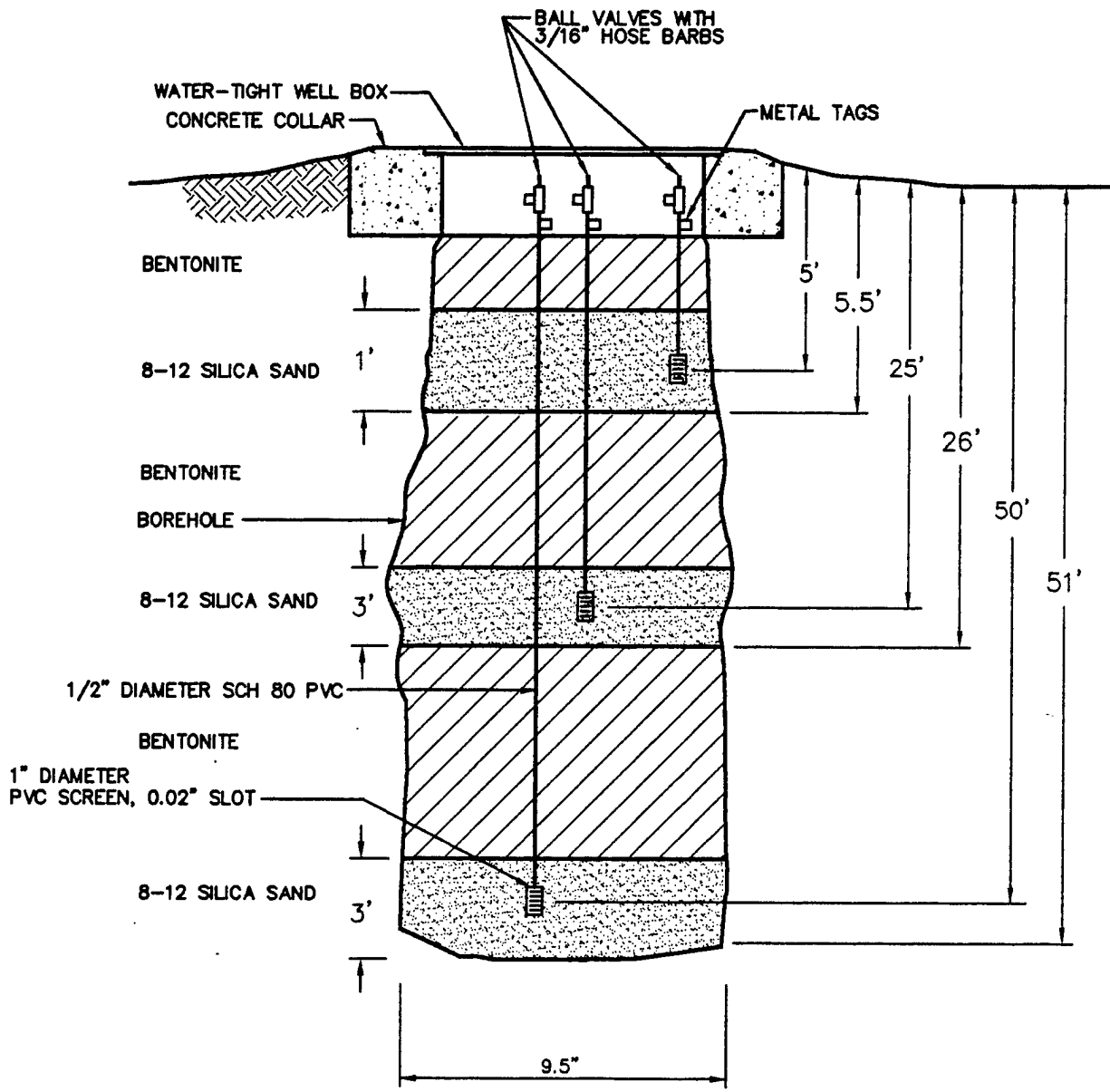

NOT TO SCALE

FIGURE 1.4
 AS-BUILT
 BACKGROUND MONITORING
 POINT CONSTRUCTION DETAIL
 SWMU #70
 CANNON AFB, NEW MEXICO
ENGINEERING-SCIENCE, INC.
 Denver, Colorado

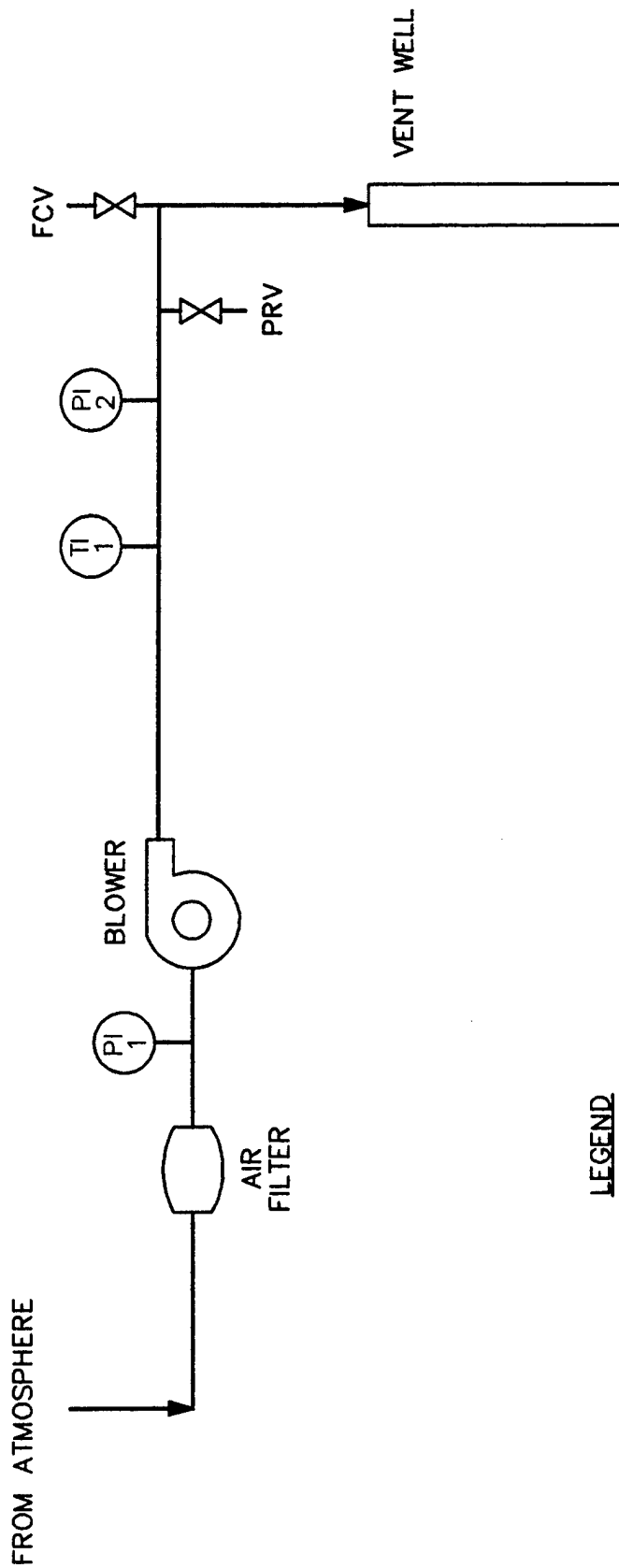

LEGEND

- PI 1 PRESSURE INDICATOR
- TI 1 TEMPERATURE INDICATOR
- FCV FLOW CONTROL VALVE
- PRV PRESSURE RELIEF VALVE

FIGURE 1.5

**AS-BUILT EXTENDED PILOT TEST
BLOWER SYSTEM
INSTRUMENTATION DIAGRAM
FOR AIR INJECTION
SWMU #70**

CANNON AFB, NEW MEXICO

ENGINEERING-SCIENCE, INC.

Denver, Colorado

an operations and maintenance (O&M) briefing, checklist, and blower maintenance manual to base personnel. A copy of the checklist is provided in Appendix C.

2.0 PILOT TEST SOIL AND SOIL GAS SAMPLING RESULTS

2.1 Soil Sampling

2.1.1 Soil Sampling Methods and Rationale

At the request of the EPA Region VI office, soil sampling activities performed at Cannon AFB SWMU #70 were considerably more extensive than sampling activities typically performed at bioventing sites under the AFCEE program. In a letter dated January 25, 1994, ES agreed to sample the VW soil at 10-foot intervals until two consecutive soil headspace readings for volatile organics, measured with a photoionization detector (PID), were below 20 parts per million, volume per volume (ppmv). Soil samples from the 10-foot intervals were analyzed for total recoverable petroleum hydrocarbons (TRPH) by EPA Method 418.1, and benzene, toluene, ethylbenzene, and xylenes (BTEX) by Method SW8020. In addition, ES agreed to screen soil cutting headspaces at 5-foot intervals for all boreholes; to collect soil samples from each MP interval to be installed; and to analyze these samples for TRPH and BTEX. The intent of sampling the VW more frequently was to fully define the vertical extent of hydrocarbon contamination in the borehole thought to be closest to the leach well. Soil samples at MPA were collected and analyzed for TRPH and BTEX with a greater frequency than agreed upon because the leach well was believed to have been penetrated during drilling of MPA. Sampling at MPA proceeded at 10 foot intervals as described for the VW. One sample was also selected from each of the VW, MPA, and MPB for analysis of iron; alkalinity; pH; total Kjeldahl nitrogen (TKN); phosphates; moisture content and grain size distribution as specified in the protocol document (Hinchee et al., 1992). At AFCEE's request two samples from the site were selected for analysis of semivolatile organic compounds by Method SW8270.

Boreholes were advanced using a model DWP-1200T40k dual tube percussion drill rig. At the specified intervals, soil samples were collected using split-spoon samplers lined with 2-inch-diameter, 4-inch-long, brass liners. Upon retrieval of the split-spoon from the borehole, each brass liner was screened with a PID to select the interval with the highest suspected volatile organic contamination for laboratory analysis of organic parameters. Soil samples were shipped on ice via Federal Express® to the Pace, Inc. laboratory in Huntington Beach, California for chemical and physical analysis. Chain-of-custody forms are provided in Appendix D.

Soil samples for headspace analysis were collected from drill cuttings or split spoons and placed in a sealable plastic bag. Alternately, headspace samples were placed in clean sample jars and sealed with aluminum foil. Samples were placed in a warm location and allowed to equilibrate for at least 10 minutes. The headspace reading was collected by inserting the probe of the PID into the plastic bag or through the aluminum foil.

The total depth of drilling and sampling activities at the site were initially defined by the headspace readings of soil samples collected from the VW borehole as per the January 25, 1994 letter. Two consecutive headspace readings of less than 20 ppmv were collected from the 100 foot and 110 foot soil samples. Headspace readings are provided on the borehole

logs included in Appendix A. During drilling of MPA, higher levels of soil contamination were suspected based upon headspace readings. In MPA, headspace readings significantly decreased below 75 feet bgs until a perched lense of water was encountered at 102 feet bgs. The wet cuttings from this interval had a foul odor and resulted in a headspace reading of approximately 150 ppmv. Soil samples below the perched water had headspaces ranging from 0 to 22 ppmv. The borehole was completed to 123 feet bgs, where a headspace of 0 ppmv was obtained.

Soil samples collected in the upper 60 feet from the borehole for MPB resulted in headspace readings ranging up to 550 ppmv. Below 60 feet bgs all soil sample headspace readings were below 50 ppmv. All headspace readings from soil samples collected at MPC were below 25 ppmv, indicating that MPC is outside the aerial extent of soil contamination.

2.1.2 Site Geology

Soil types were logged at 5-foot intervals during drilling activities. In addition, three soil samples were analyzed for grain size distribution. This information was used to develop borehole logs that are included in Appendix B and the geologic cross section shown as Figure 2.1.

Near-surface soils generally consisted of silts and clays to a depth of approximately 17 feet bgs. The silts and clays were typically medium brown, hard, and dry. In the borehole for MPA, a layer of grossly contaminated gravel and small cobbles was encountered from approximately 9 to 14 feet bgs. Visual and olfactory observations identified the contamination as petroleum related. It is suspected that these materials are part of the leach well.

Sands with silt and clay were observed from approximately 17 to 32 feet bgs. The grain size distribution results from sample MPA-20 indicated that 18 percent by weight of the sample was gravel. However, no gravel was observed in the field, and it is suspected that pieces of consolidated silty-clayey sand were retained in the number 4 sieve. The soil in this region typically ranged from light to medium brown.

A silty sand with layers of caliche was encountered below 32 feet bgs. The bottom of this formation ranged from 72 feet bgs at the VW to 58 feet bgs in MPC. The grain size analysis results indicate that 32 percent by weight of the soil was gravel. The gravel fraction was characterized by fragments of caliche, broken up during drilling that were retained in the number 4 sieve. No gravel other than caliche fragments was observed in the soils in this region. The caliche fragments had distinct calcareous cemented appearance. The caliche layers were very hard and spread throughout this interval. No distinct continuous layers of caliche could be identified. Soil color typically ranged from light to medium brown.

A fine- to medium-grained sand with discontinuous layers of sandstone was encountered beneath the silty sand. This formation extended to 116 feet in borehole MPA and continued beyond the total depths of boreholes VW, MPB, and MPC, each having a total depth of 112 feet bgs. The sand was predominantly light brown. Broken fragments and whole pieces of hard sandstone were recovered from the boreholes. A perched water zone was encountered in the borehole for MPA between approximately 102 and 106 feet bgs. The water had a foul, though not distinctly hydrocarbon, odor, and had a measured headspace reading of 150 ppmv. Soils below 106 feet bgs were dry. It is possible that a larger piece of sandstone impeded

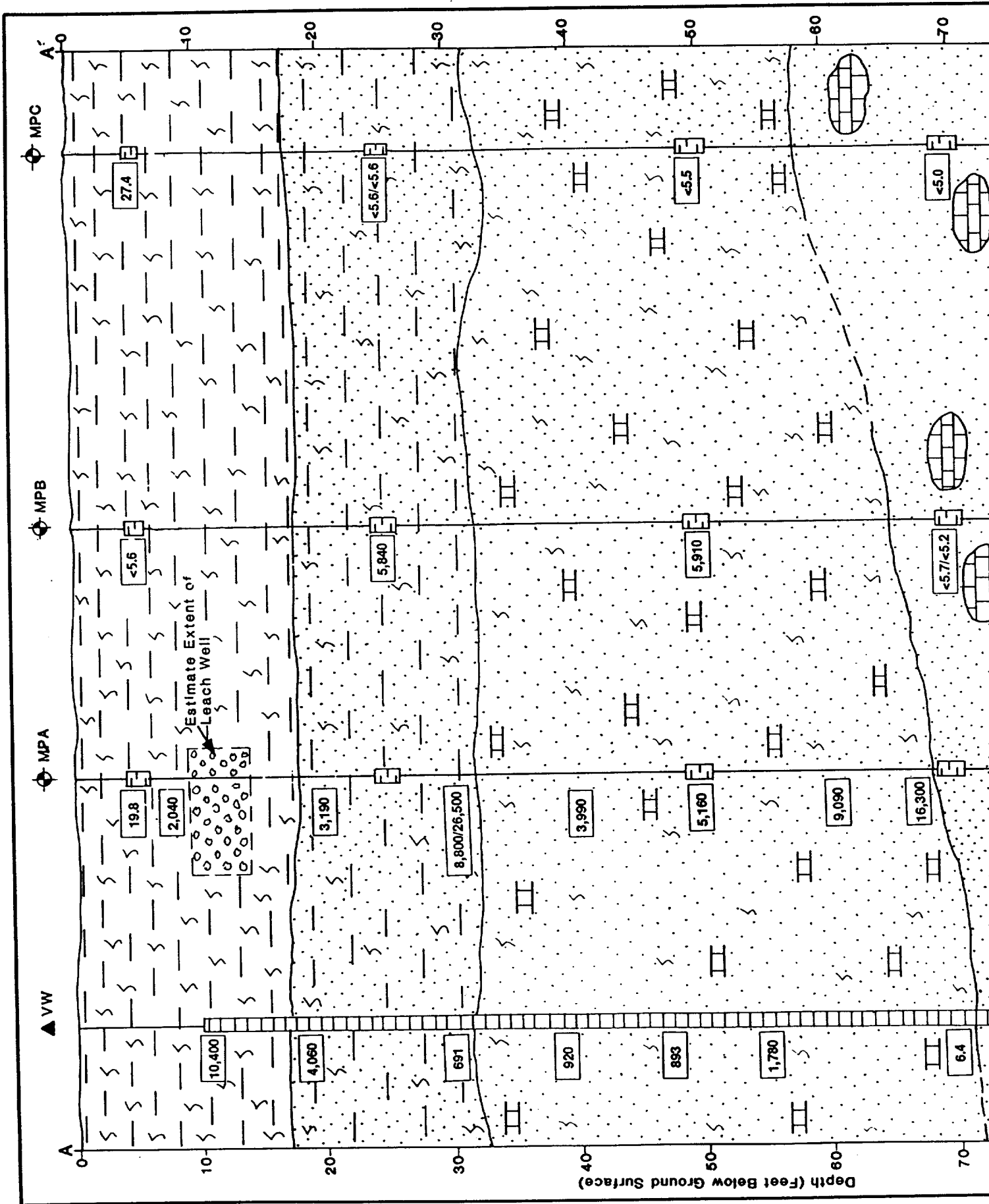

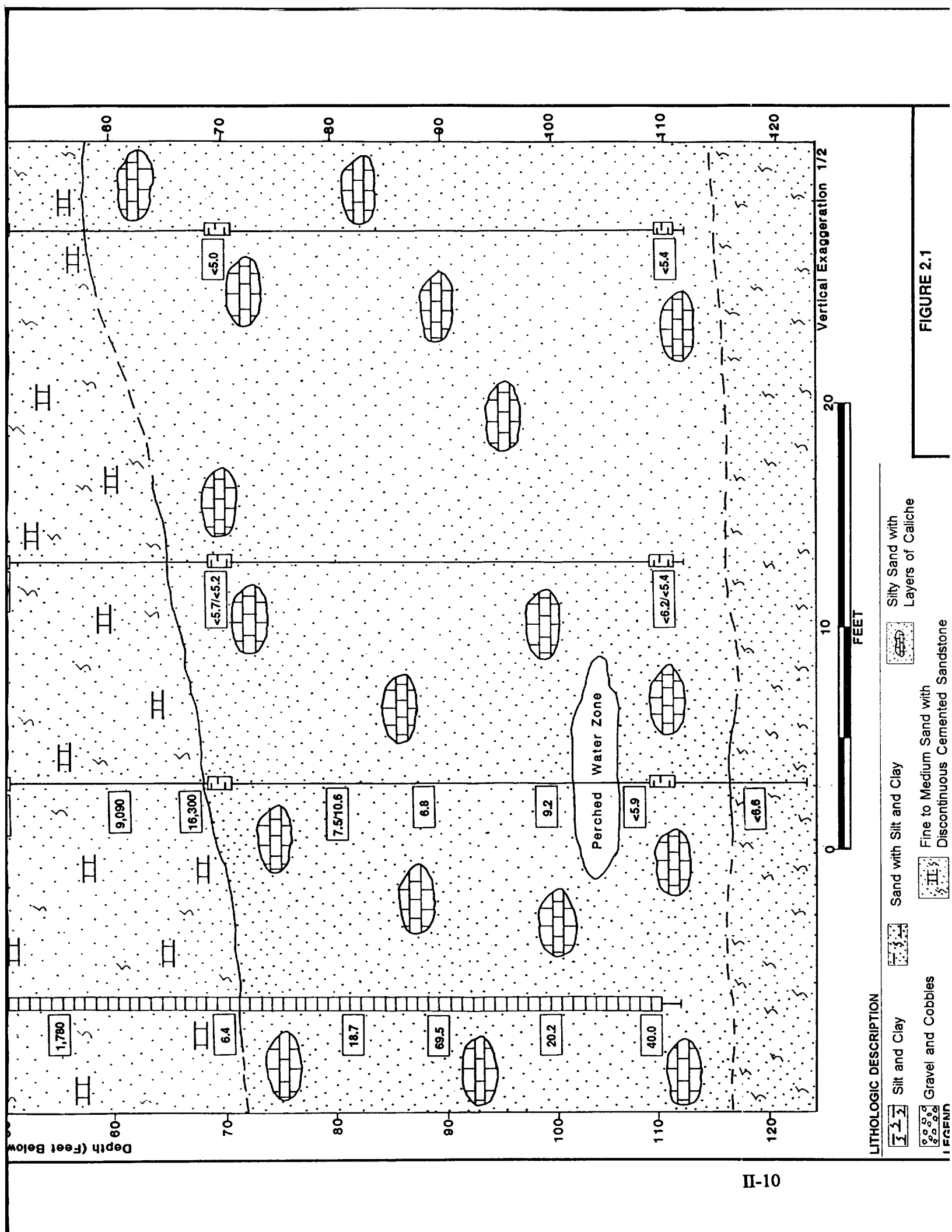
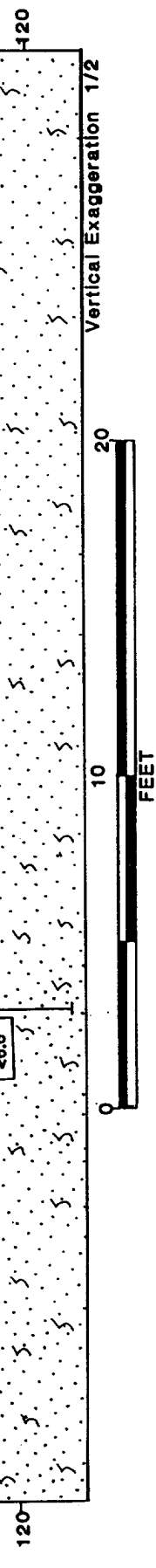







FIGURE 2.1



LITHOLOGIC DESCRIPTION

-  Silt and Clay
-  Sand with Silt and Clay
-  Silty Sand with Layers of Caliche
-  Gravel and Cobbles
-  Fine to Medium Sand with Discontinuous Cemented Sandstone

LEGEND

-  Vent Well
-  Monitoring Point
-  Monitoring Point Screened Interval
-  Vent Well Screened Interval
-  Geologic Contact, Dashed Where Inferred
-  Laboratory Results for total Petroleum Hydrocarbons in Soil (mg/kg)

1,780

FIGURE 2.1

**GEOLOGIC
CROSS SECTION A-A'
SWMU #70**

Cannon AFB, New Mexico

ENGINEERING-SCIENCE, INC.

Denver, Colorado

vertical migration of the water at this location. A silty sand was encountered in MPA below 116 feet bgs. Other than the perched water in MPA, groundwater was not encountered in any borehole at the site.

2.1.3 Soil Sampling Results

The distribution of TRPH is shown in Figure 2.1 and in Table 2.1. The two highest concentrations of TRPH [26,500 milligrams per kilogram (mg/kg) and 16,300 mg/kg] were found in MPA in samples collected below the leach well. Each of these detections occurred at the bottom of a lithologic unit (Figure 2.1). Samples collected from higher in each unit had progressively lower concentrations of TRPH (e.g., 16,300 mg/kg at 70 feet, 9,090 mg/kg at 60 feet, 5,160 mg/kg at 50 feet, and 3,990 mg/kg at 40 feet in MPA). Samples collected from the VW borehole had elevated TRPH concentrations to a depth of 60 feet bgs; however, the lithologic correlation with TRPH results observed in the borehole for MPA was not apparent in borehole VW. Elevated TRPH concentrations were detected in the 25- and 50-foot samples at MPB; however, there are not a sufficient number of samples to determine if a lithologic correlation is present. The aerial extent of TRPH contamination is less than 25 feet from the leach well in the direction of MPC, where little or no TRPH was detected.

Based on the BTEX concentration data presented in Table 2.1, it appears that the majority of BTEX contamination is within the effective treatment radius and depth of the pilot test bioventing system. Toluene appears to have migrated deepest into the soils, with detectable concentrations at 100 feet bgs in the VW, 120 feet bgs in MPA, 110 feet bgs in MPB, and 90 feet bgs in MPC. The deepest ethylbenzene detection was at 90 feet bgs in the VW boring, and none was detected in MPC. The deepest detections of xylenes were at 110 feet bgs in the VW and MPB (duplicate sample), and none was detected in MPC. It is important to note that the concentrations of toluene and xylenes that were detected in the 110 and 120 foot samples were in the micrograms per kilogram range and were close to the method detection limits.

The distribution of benzene is more limited, with detectable concentrations to 60 feet bgs in the VW, 70 feet bgs in MPA, and 25 feet bgs in MPC. Benzene was not detected in any of the soil samples collected from borehole MPB; however, Draeger® tube analyses detected benzene in the breathing zone air during drilling at concentrations up to 1.5 ppmv (borehole depth approximately 55 feet). Level C respiratory protection was worn while drilling from 50 to 70 feet at borehole MPB due to the presence of benzene in the breathing zone. It is believed that benzene was present in the 50-foot sample from borehole MPB. Due to high toluene, ethylbenzene, and xylenes concentrations, sample MPB-50 was diluted by a factor of 5,000. As a result the detection limit for benzene was increased by a factor of 5,000, and benzene was not detected above this elevated detection limit. It is also probable that benzene was present in sample MPB-25, which was diluted by a factor of 500.

Field duplicate samples were collected at 30 and 80 feet bgs in MPA, 70 and 110 feet bgs in MPB, and 25 feet bgs in MPC. Field duplicates were collected by submitting an adjacent brass liner, labeled with a coded sample identification, from the same split-spoon sampler as the primary sample. Table 2.2 compares the results of the field duplicates and shows the calculated relative percent differences (RPDs). RPDs were not calculated for analytes with a nondetect result. RPDs for BTEX and TRPH compounds were high for several analytes. Variability in hydrocarbon distribution is again likely responsible.

TABLE 2.1
SOIL TRPH AND BTEX ANALYTICAL RESULTS
SWMU #70
CANNON AFB, NEW MEXICO

Sample Location-Depth (feet below ground surface)	Analyte				
	TRPH (mg/kg) ^{a/}	Benzene (mg/kg)	Toluene (mg/kg)	Ethylbenzene (mg/kg)	Xylenes (mg/kg)
VW-10	10400	20	144	97	310
VW-20	4060	2.2	17	33	130
VW-30	691	<0.57	1.5	4.0	15
VW-40	920	<0.58	1.3	4.2	17
VW-50	893	0.66	6.6	7.3	38
VW-60	1780	0.21	2.3	6.4	36
VW-70	6.4	<0.0006	<0.0006	<0.0006	<0.0008
VW-80	18.7	<0.0005	0.0010	0.0007	0.0024
VW-90	69.5	<0.069	0.11	0.16	0.53
VW-100	20.2	<0.0005	0.0005	<0.0005	<0.0007
VW-110	40.0	<0.0005	<0.0005	<0.0005	0.0011
MPA-5	19.8	<0.0006	<0.0006	0.0008	0.0039
MPA-9	2040	3.7	28	16	55
MPA-20	3190	3.3	29	20	71
MPA-30	8800	4.6	36	48	180
MPA-130 ^{b/}	26500	5.8	84	57	210
MPA-40	3990	2.4	4.2	36	140
MPA-50	5160	1.4	26	26	92
MPA-60	9090	<2.8	48	59	200
MPA-70	16300	11	76	78	390
MPA-80	7.5	<0.0006	0.0007	<0.0006	0.013
MPA-140 ^{c/}	10.6	<0.0005	<0.0005	<0.0005	0.0009
MPA-90	6.8	<0.0006	0.0059	<0.0006	<0.0008
MPA-100	9.2	<0.0006	<0.0006	<0.0006	<0.0008
MPA-110	<5.9	<0.0006	0.0032	<0.0006	<0.0008
MPA-120	6.6	<0.0005	0.0006	<0.0005	<0.0007
MPB-5	<5.6	<0.0006	<0.0006	<0.0006	<0.0007
MPB-25	5840	<0.29	2.0	2.5	11
MPB-50	5910	<2.8	39	51	190
MPB-70	<5.7	<0.0006	<0.0006	<0.0006	0.001
MPB-140 ^{d/}	<5.2	<0.0005	0.0022	<0.0005	0.0009
MPB-110	6.2	<0.0006	0.0057	<0.0006	<0.0008
MPB-155 ^{e/}	<5.4	<0.0005	0.0012	<0.0005	0.0014

TABLE 2.1 (Continued)
SOIL TRPH AND BTEX ANALYTICAL RESULTS
SWMU #70
CANNON AFB, NEW MEXICO

Sample Location-Depth (feet below ground surface)	Analyte				
	TRPH (mg/kg) ^{a/}	Benzene (mg/kg)	Toluene (mg/kg)	Ethylbenzene (mg/kg)	Xylenes (mg/kg)
MPC-5	27.4	<0.0006	0.0016	<0.0006	<0.0008
MPC-25	<5.6	0.0006	0.0050	<0.0006	<0.0008
MPC-90 ^{f/}	<5.6	<0.0006	0.0006	<0.0006	<0.0008
MPC-50	<5.5	<0.0005	0.0040	<0.0005	<0.0007
MPC-70	<5.0	<0.0005	0.0014	<0.0005	<0.0007
MPC-110	<5.4	<0.0005	<0.0005	<0.0005	<0.0007

^{a/} mg/kg = milligrams per kilogram; TRPH = total recoverable petroleum hydrocarbons.

^{b/} Field duplicate of sample MPA-30..

^{c/} Field duplicate of sample MPA-80.

^{d/} Field duplicate of sample MPB-70.

^{e/} Field duplicate of sample MPB-110.

^{f/} Field duplicate of sample MPC-25.

TABLE 2.2
FIELD QA/QC ANALYTICAL RESULTS
SWMU #70
CANNON AFB, NEW MEXICO

Analyte (Units)	Primary Sample	Field Duplicate	RPD ^{b/}
<u>Soil Hydrocarbons</u>			
	<u>MPA-30</u>	<u>MPA-130</u>	
TRPH (mg/kg) ^{a/}	8800	26500	100%
Benzene (mg/kg)	4.6	5.8	23%
Toluene (mg/kg)	36	84	80%
Ethylbenzene (mg/kg)	48	57	17%
Xylenes (mg/kg)	180	210	15%
<u>Soil Hydrocarbons</u>			
	<u>MPA-80</u>	<u>MPA-140</u>	
TRPH (mg/kg)	7.5	10.6	34%
Benzene (mg/kg)	<0.0006	<0.0005	-- ^{c/}
Toluene (mg/kg)	0.0007	<0.0005	--
Ethylbenzene (mg/kg)	<0.0006	<0.0005	--
Xylenes (mg/kg)	0.013	0.0009	174%
<u>Soil Hydrocarbons</u>			
	<u>MPB-70</u>	<u>MPB-140</u>	
TRPH (mg/kg)	<5.7	<5.2	--
Benzene (mg/kg)	<0.0006	<0.0005	--
Toluene (mg/kg)	<0.0006	0.0022	--
Ethylbenzene (mg/kg)	<0.0006	<0.0005	--
Xylenes (mg/kg)	0.001	0.0009	11%
<u>Soil Hydrocarbons</u>			
	<u>MPB-110</u>	<u>MPB-155</u>	
TRPH (mg/kg)	6.2	<5.4	--
Benzene (mg/kg)	<0.0006	<0.0005	--
Toluene (mg/kg)	0.0057	0.0012	130%
Ethylbenzene (mg/kg)	<0.0006	<0.0005	--
Xylenes (mg/kg)	<0.0008	0.0014	--
<u>Soil Hydrocarbons</u>			
	<u>MPC-25</u>	<u>MPC-90</u>	
TRPH (mg/kg)	<5.6	<5.6	--
Benzene (mg/kg)	0.0006	<0.0006	--
Toluene (mg/kg)	0.0050	0.0006	157%
Ethylbenzene (mg/kg)	<0.0006	<0.0006	--
Xylenes (mg/kg)	<0.0008	<0.0008	--

a/ TRPH= Total recoverable petroleum hydrocarbons; mg/kg = milligrams per kilogram.

b/ RPD = Relative percent difference between primary sample and field duplicate.

c/ -- = RPD not calculated.

Semivolatile analysis by Method SW8270 was performed on two samples, MPA-30 and MPA-70. The intent was to determine if semivolatile constituents were being attenuated in the soil column, resulting in higher concentrations closer to the source area and lower concentrations in deeper soils. The 30-foot deep sample was collected approximately 16 feet below the bottom of the leach well. The only semivolatile compounds detected were naphthalene and 2-methylnaphthalene (Table 2.3). Naphthalene and 2-methylnaphthalene are typical fuel-related semivolatile organics. In the MPA-70 sample, naphthalene and 2-methylnaphthalene were again the only semivolatile compounds detected; however, they were detected in concentrations greater than at MPA-30. Likewise the TRPH and BTEX concentrations in MPA-70 were close to twice as high as those in MPA-30. It is possible that product that historically passed through the leach well was forced into deeper soils by cleaner water passing through the leach well more recently. General soil heterogeneity must also be considered as a factor in sample variability. Another possibility is that product migrating vertically through the soil column is impeded at the 70 foot lithologic contact in borehole MPA. If vertical migration is impeded, accumulation of the migrating product would occur. Based on the results, no significant attenuation of semivolatiles appears to have occurred in this scenario.

Table 2.4 presents the results of the nutrient and physical parameter analyses performed on three select samples from the site and one sample for the background MP. The sample from the background MP was analyzed for TKN only.

2.2 Soil Gas Sampling Results

Soil gas samples were collected by extracting soil gas from a depth of 5 feet bgs from MPA, 70 feet bgs from MPC, and from the VW. Soil gas samples were shipped via Federal Express to Air Toxics, Inc. in Folsom, California for total volatile hydrocarbon (TVH) and BTEX analysis. A field duplicate sample was collected from MPA-5 and was labeled MPA-140. Analytical results for the soil gas samples and the RPDs for MPA-5 and its duplicate sample are presented in Table 2.5. RPDs are a measure of the precision of the analyses. The RPDs are all within the acceptable criteria and demonstrate excellent precision by the analytical laboratory.

2.3 Exceptions To Test Protocol Document Procedures

Procedures described in the protocol document (Hinchee et al., 1992) were used to complete treatability tests at SWMU #70. As described in Section 2.1.1, field screening, sampling, and analytical procedures were more extensive to meet EPA Region VI requests. Another exception to the work plan was the failure to collect helium data during the respiration test. Although approximately 3 percent helium was injected into three MP intervals, a helium detector malfunction prohibited collection of the data. A helium injection will be reported during the one-year respiration testing to collect information on possible oxygen loss due to diffusion.

TABLE 2.3
SOIL SEMIVOLATILE ANALYTICAL RESULTS
SWMU #70
CANNON AFB, NEW MEXICO

Analyte	Sample Location-Depth (feet below ground surface)	
	MPA-30 (mg/kg) ^{a/}	MPA-70 (mg/kg)
Phenol	<3.8	<6.8
2-Chlorophenol	<2.5	<4.5
1,3-Dichlorobenzene	<1.3	<2.3
1,4-Dichlorobenzene	<1.3	<2.3
1,2-Dichlorobenzene	<1.3	<2.3
2-Nitrophenol	<1.3	<2.3
2,4-Dimethylphenol	<1.3	<2.3
2,4-Dichlorophenol	<2.5	<4.5
1,2,4-Trichlorobenzene	<2.5	<4.5
Naphthalene	7.9	42
2-Methylnaphthalene	17	67
Acenaphthylene	<2.5	<4.5
2,4-Dinitrotoluene	<2.5	<4.5
2,6-Dinitrotoluene	<3.8	<6.8
Fluorene	<1.3	<2.3
Hexachlorobenzene	<2.5	<4.5
Phenanthrene	<2.5	<4.5
Anthracene	<2.5	<4.5
Pyrene	<3.8	<6.8
Benzo(a)Anthracene	<2.5	<4.5
Chrysene	<2.5	<4.5
Benzo(b)Fluoranthene	<2.5	<4.5
Benzo(a)Pyrene	<2.5	<4.5

a/ mg/kg = milligram per kilogram.

TABLE 2.4
SOIL INORGANICS AND PHYSICAL PARAMETER ANALYTICAL RESULTS
SWMU #70
CANNON AFB, NEW MEXICO

Analyte (Units) ^{a/}	Sample Location-Depth (feet below ground surface)			
<u>Soil Inorganics</u>	<u>VW-20</u>	<u>MPA-20</u>	<u>MPB-50</u>	<u>MPBG-25</u>
Iron (mg/kg)	6780	7870	5050	NA ^{b/}
Alkalinity (mg/kg as CaCO ₃)	2398	730	318	NA
pH (standard units)	8.3	8.0	8.8	NA
TKN (mg/kg)	230	260	69	56
Phosphate (mg/kg)	90	110	28	NA
<u>Soil Physical Parameters</u>	<u>VW-65</u>	<u>MPA-42</u>	<u>MPB-50</u>	
Moisture (% wt.)	11.5	16.0	9.1	
Gravel (%)	0.7	17.8	32.1	
Sand (%)	65.0	50.8	50.1	
Silt (%)	15.1	14.8	14.7	
Clay (%)	19.2	16.6	3.1	
<u>Soil Temperature (°C)</u>	<u>MPA-5</u>	<u>MPA-110</u>		
	18.6	17.7		

^{a/} mg/kg = milligrams per kilogram; volume per volume; CaCO₃ = calcium carbonate; TKN = total Kjeldahl nitrogen; °C = degrees Celcius.

^{b/} NA = not analyzed.

TABLE 2.5
SOIL GAS ANALYTICAL RESULTS
SWMU #70
CANNON AFB, NEW MEXICO

Analyte (Units) ^{a/}	Sample Location-Depth (feet below ground surface)			
	<u>VW 10-110</u>	<u>MPA-5</u>	<u>MPA-140^{b/}</u>	<u>MPC-50</u>
<u>Soil Gas Hydrocarbons</u>				
TVH (ppmv)	3,900	23,000	23,000	120
Benzene (ppmv)	6.3	84	82	<0.003
Toluene (ppmv)	21	32	32	0.010
Ethylbenzene (ppmv)	9.2	13	12	0.007
Xylenes (ppmv)	27	41	41	0.063

Relative Percent Difference - MPA-5 and MPA-140

<u>Soil Gas Hydrocarbons</u>	<u>RPD (%)</u>
TVH (ppmv)	0.0
Benzene (ppmv)	2.4
Toluene (ppmv)	0.0
Ethylbenzene (ppmv)	8.0
Xylenes (ppmv)	0.0

^{a/} ppmv = parts per million, volume per volume.

^{b/} MPA-140 is a field duplicate of MPA-5.

3.0 PILOT TEST RESULTS

3.1 Initial Soil Gas Chemistry

Prior to initiating air injection, all MPs and the VW were purged until oxygen levels had stabilized, and initial oxygen, carbon dioxide, and TVH concentrations were sampled using portable gas analyzers as described in the protocol document (Hinchee et al., 1992). At all MPA and the MPB-25 and -50 screened intervals, microorganisms had significantly depleted soil gas oxygen supplies, indicating significant biological activity and soil contamination. Elevated levels of carbon dioxide corresponded with elevated levels of TVH and low levels of oxygen, as expected. Soil gas samples taken from a background (BG) well contained near atmospheric levels of oxygen and carbon dioxide indicating that oxygen utilization in SWMU 70 soils was the result of fuel biodegradation, and little or no oxygen uptake can be attributed to abiotic oxygen demand. Table 3.1 summarizes the initial soil gas chemistry.

3.2 Air Permeability

An air permeability test was conducted on site soils according to protocol document procedures. Air was injected into the VW for 3.25 hours at a rate of approximately 61 scfm and an average pressure of 32 inches of water. The maximum pressure response at each MP is listed in Table 3.2. The pressure measured at the MPs steadily increased throughout the period of air injection. A radius of pressure influence of at least 34 feet was observed at the 50, 70 and 110-foot depths. A radius of pressure influence of approximately 20 feet was observed at the 25-foot depth. No significant pressure response was observed at the 5 foot depth.

Both the dynamic method (Hyperventilate model) and the steady-state method were used to estimate the air permeability. Calculations are provided in Appendix E. Soil gas permeabilities calculated using Method 1 from the Hyperventilate model (known flow rate and screened interval length) ranged from 5.7 to 9.6 darcys at the 50 foot depth, 3.4 to 5.9 darcys at the 70 foot depth, and 3.9 to 6.8 darcys at the 110 foot depth. The corresponding results using the steady-state method were 1.8 darcys at the 50 foot depth, 2.0 darcys at the 70 foot depth, and 2.0 darcys at the 110 foot depth. The steady-state method results were consistently lower than the dynamic method results, but still within the same order of magnitude for these intervals. All results for these intervals are within the range given for medium sand (Johnson, 1990) and are higher than expected for the observed soil types (silty, fine sands). This has been a common observation at bioventing sites and results from the fact that most soils are nonuniform and have layers of variable permeability. The steady-state method resulted in a permeability of 1.6 darcys at the 25 foot depth, while the Hyperventilate model resulted in a range of permeabilities from 21 to 27 darcys. Both are within the range for a medium sand and an order of magnitude higher than expected for the soil types observed at 25 feet bgs. Pressure responses at the 5 foot depths were not significant enough to calculate reasonable permeabilities using either method.

TABLE 3.1
INITIAL SOIL GAS CHEMISTRY
SWMU #70
CANNON AFB, NEW MEXICO

Sample Location	Depth (ft)	O ₂ ^{a/} (%)	CO ₂ ^{b/} (%)	Field TVH ^{c/} (ppmv) ^{d/}	Lab ^{e/} TVH (ppmv)	Soil TRPH ^{f/} (mg/kg) ^{g/}
MPA	5	0.0	10.2	<20,000	23,000	19.8
MPB	5	12.8	2.6	1,200	NS ^{h/}	<5.6
MPC	5	18.9	2.3	85	NS	27.4
BG	5	20.1	0.6	350	NS	NS
MPA	25	0.0	13.1	18,900	NS	8,800 ^{i/}
MPB	25	0.0 ^{e/}	15.3 ^{e/}	11,400 ^{j/}	NS	5,840
MPC	25	12.5	0.1	220	NS	<5.6
BG	25	20.2	0.3	110	NS	NS
MPA	50	0.0	6.0	11,800	NS	5,160
MPB	50	0.0	9.1	12,000	NS	5,910
MPC	50	10.0	6.1	240	120	<5.5
BG	50	19.8	0.5	205	NS	NS
MPA	70	0.0	12.5	7,000	NS	16,300
MPB	70	7.6	5.0	1,000	NS	<5.7
MPC	70	10.6	7.6	260	NS	<5.0
MPA	110	9.8	8.1	1,450	NS	<5.9
MPB	110	12.8	5.3	310	NS	6.2
MPC	110	14.3	4.8	260	NS	<5.4
VW	10-110	11.8	6.4	2,200	3,900	NA ^{k/}

^{a/} O₂ = Oxygen.

^{b/} CO₂ = Carbon dioxide.

^{c/} TVH = Total volatile hydrocarbons.

^{d/} Field screening results, in parts per million, volume per volume (ppmv).

^{e/} Laboratory results.

^{f/} TRPH = Total recoverable petroleum hydrocarbons.

^{g/} Laboratory soil results, in milligrams per kilogram (mg/kg).

^{h/} NS = not sampled.

^{i/} MPB-25 initially was saturated from construction, sample collected following respiration testing.

^{j/} Result from the 30-foot sample.

^{k/} NA = not applicable.

3.3 Oxygen Influence

The depth and radius of oxygen increase in the subsurface resulting from air injection into the central VW during pilot testing is the primary design parameter for full-scale bioventing systems. Optimization of full-scale and multiple VW systems requires pilot testing to determine the volume of soil that can be oxygenated at a given flow rate and VW screen configuration.

Table 3.3 presents the change in soil gas oxygen levels that occurred during the initial 10 days of air injection. This period of air injection at approximately 15 scfm produced changes in soil gas oxygen levels at all MP depths. Oxygen concentrations at the 5-foot interval at MPB and the 5- and 25-foot intervals at MPC dropped during the initial 10 days of injection. This is the result of oxygen deficient soil gas in the upper formations slowly moving outward from the source area into clean soils. Biodegradation of fuel components transported with the soil gas will occur as the oxygen-deficient soil gas mixes with oxygen-rich soil gas in the soils away from the source area. Preferential flow of injected air was observed in the 50 through 110 foot monitoring intervals where soils are predominantly sands and silty sands. Likewise, oxygen influence was achieved rapidly in these intervals, whereas oxygen influence in the 5- and 25-foot intervals had yet to reach steady state. Based on measured changes in oxygen levels, it is anticipated that the radius of influence for a long-term bioventing system at this site will exceed 34 feet at all depths. Good oxygen influence below the less permeable, shallow soils should result in upward oxygen diffusion into these low-permeability soils. Monitoring during the extended pilot test at this site will better define the effective treatment radius at all depths.

3.4 *In Situ* Respiration Rates

The *in situ* respiration test was performed by injecting a mixture of air (oxygen) and approximately 3-percent helium (inert tracer gas) into three MP screened intervals (MPA-25, MPA-70, and MPB-50), and ambient air without helium into two MP screened intervals (MPA-5 and MPA-50) over a 19-hour period. Oxygen loss and other changes in soil gas composition over time were then measured at these intervals. Helium concentrations were not monitored during the respiration test due to a helium detector malfunction. Oxygen, TVH, and carbon dioxide were measured for a period of approximately 3 days following air injection. The measured oxygen losses were then used to calculate biological oxygen utilization rates. The results of *in situ* respiration testing for the MP intervals at this site are presented in Figures 3.1 through 3.5. Additional respiration test results are included in Appendix E. Table 3.4 provides a summary of the oxygen utilization rates.

Oxygen loss occurred at moderate rates, ranging from 0.0039 percent per minute at MPA-70 to 0.014 percent per minute at the MPA-25. At the MPA-25, oxygen dropped from 20.2 percent to 0 percent in 1,940 minutes.

Based on these oxygen utilization rates, an estimated 390 to 1,100 milligrams (mg) of fuel per kilogram (kg) of soil can be degraded each year at this site. This conservative estimate is based on air-filled porosities ranging from 0.015 to 0.10 liter per kg of soil, and a ratio of 3.5 mg of oxygen consumed for every 1 mg of fuel biodegraded. If oxygen can be uniformly distributed in these soils, moderate rates of hydrocarbon remediation are predicted.

TABLE 3.3
INFLUENCE OF AIR INJECTION AT VENT WELL
ON MONITORING POINT OXYGEN LEVELS
SWMU #70
CANNON AFB, NEW MEXICO

MP	Distance From VW (ft)	Depth (ft)	Initial O ₂ (%)	Final O ₂ (%) ^{a/}
A	9	5	0.0	18.0
B	19	5	10.4	0.0
C	34	5	18.4	2.1
A	9	25	0.0	13.8
B	19	25	0.0	0.5
C	34	25	7.7	3.3
A	9	50	0.0	16.1
B	19	50	0.0	7.9
C	34	50	6.8	18.0
A	9	70	0.0	19.5
B	19	70	7.6	20.5
C	34	70	8.7	20.7
A	9	110	9.8	20.8
B	19	110	12.2	20.8
C	34	110	12.9	20.4

^{a/} Readings taken after approximately 10 days of injection using long-term blower system.

Figure 3.1
Respiration Test
CA1-SWMU 70, CA1-MPA-5
Cannon AFB, NM

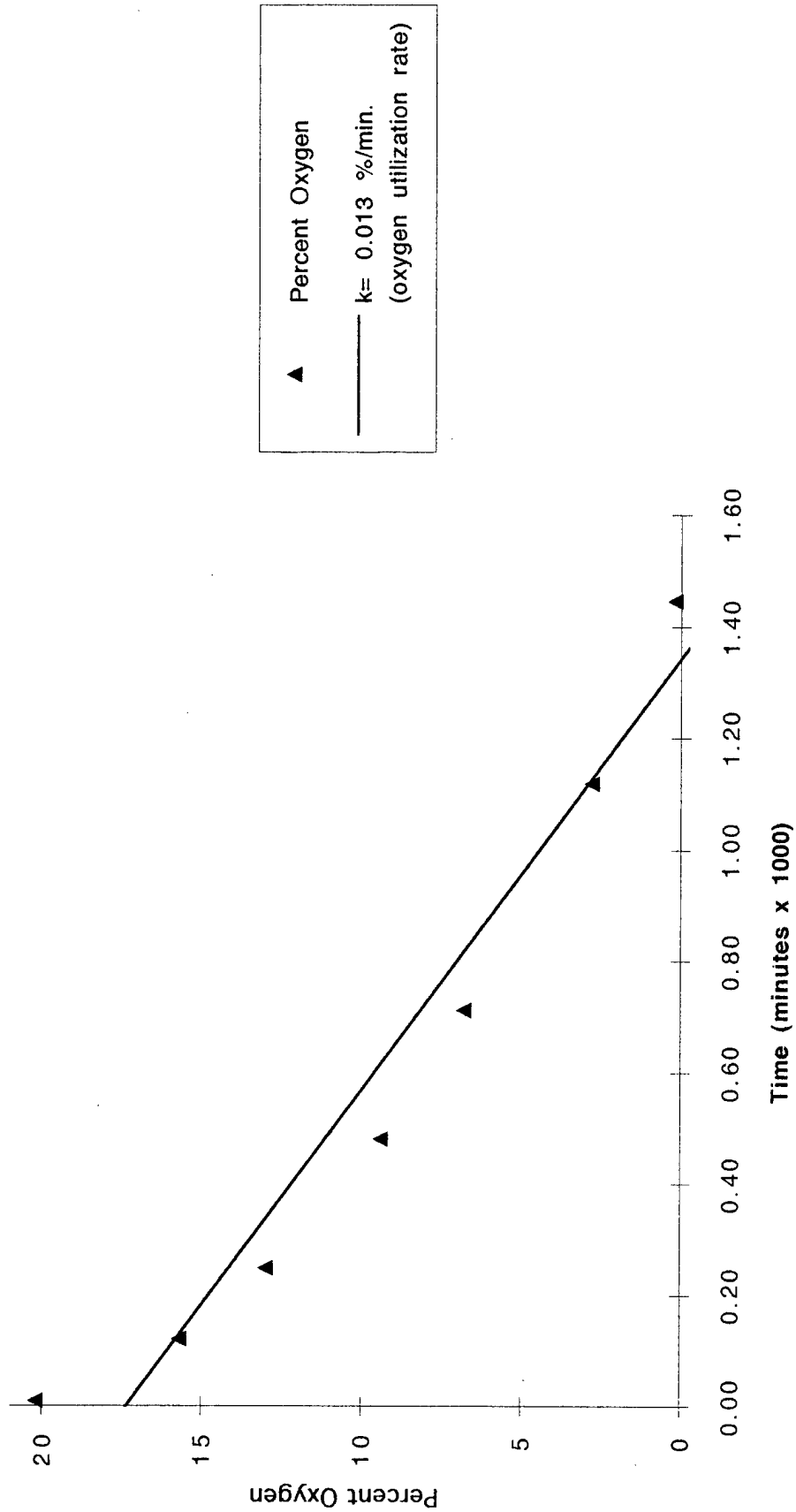

Figure 3.2
Respiration Test
CA1-SWMU 70, CA1-MPA-25
Cannon AFB, NM

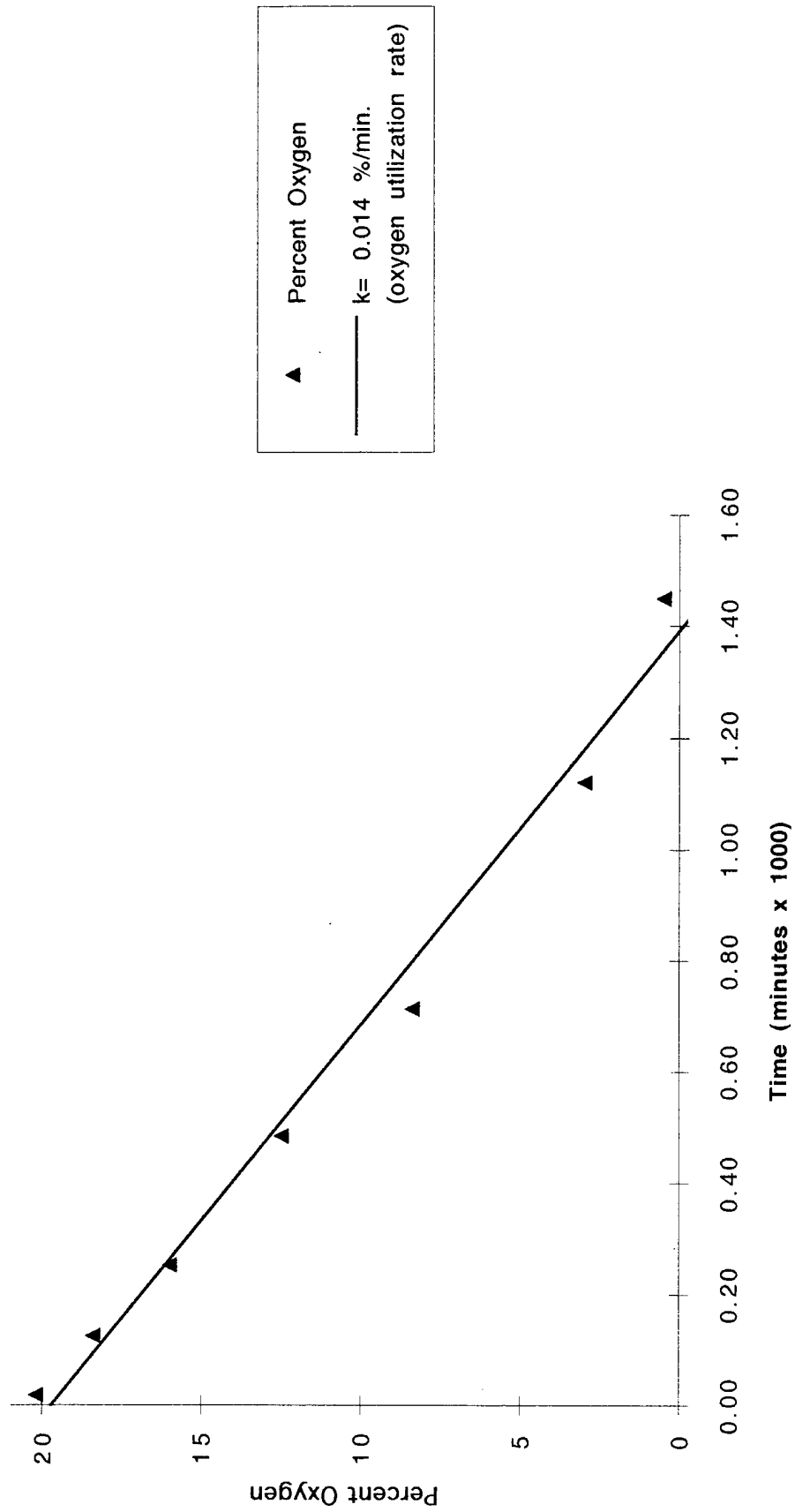

Figure 3.3
Respiration Test
CA1-SWMU 70, CA1-MPA-50
Cannon AFB, NM

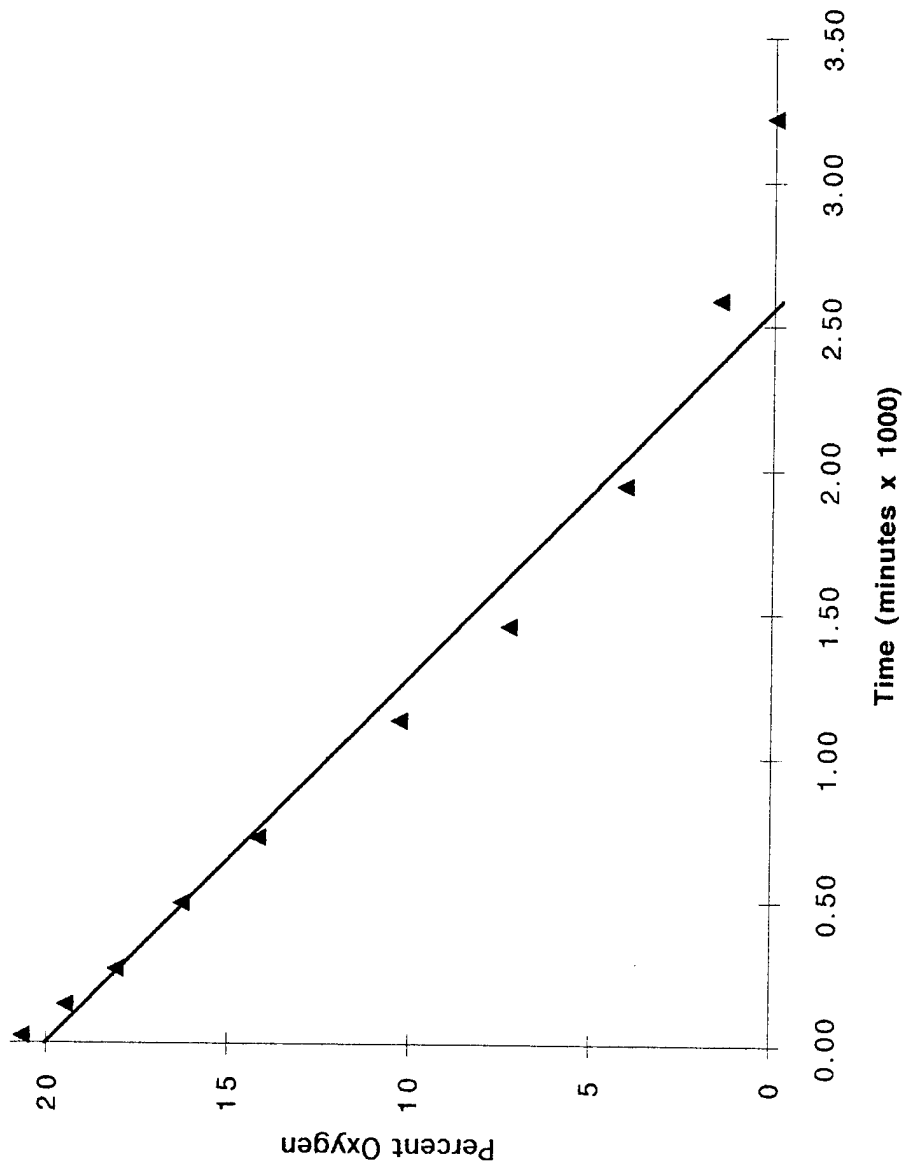

Figure 3.4
Respiration Test
CA1-SWMU 70, CA1-MPA-70
Cannon AFB, NM

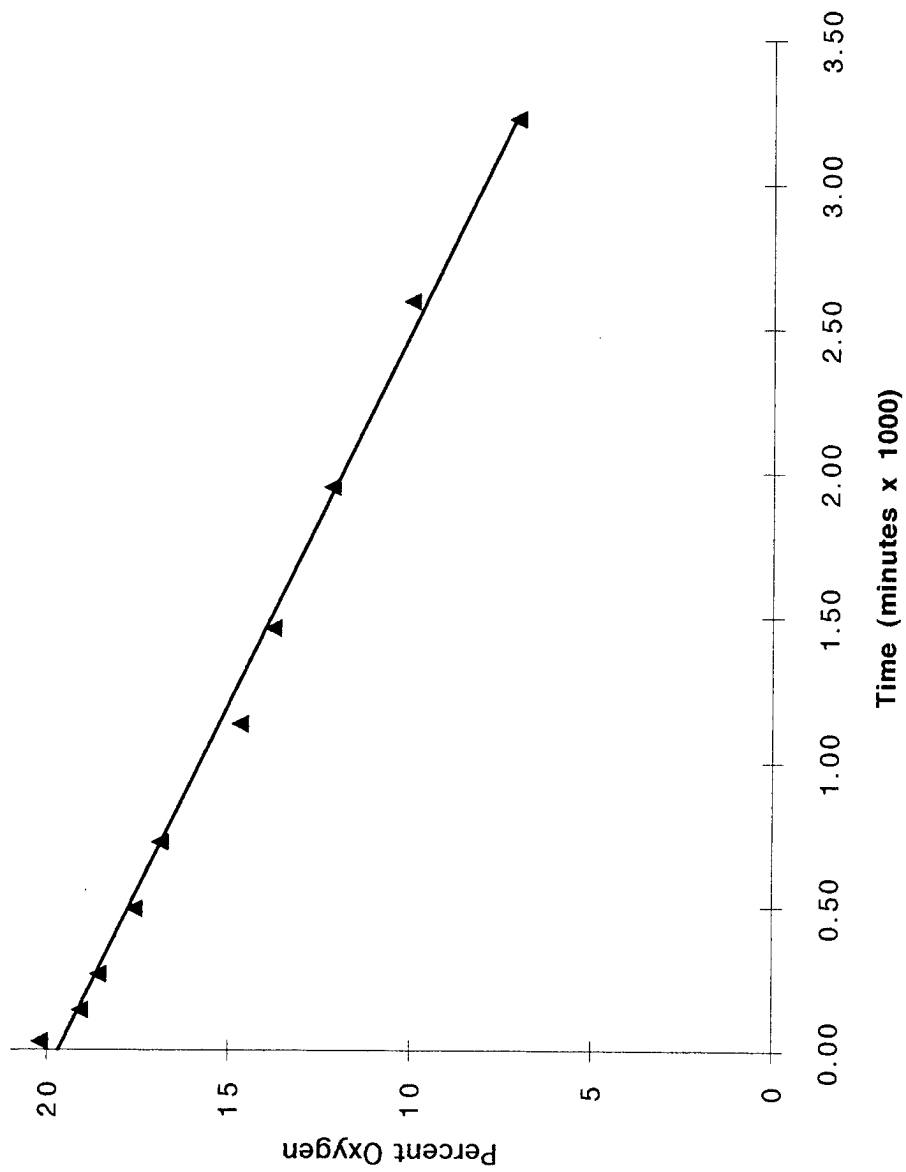

Figure 3.5
Respiration Test
CA1-SWMU 70, CA1-MPB-50
Cannon AFB, NM

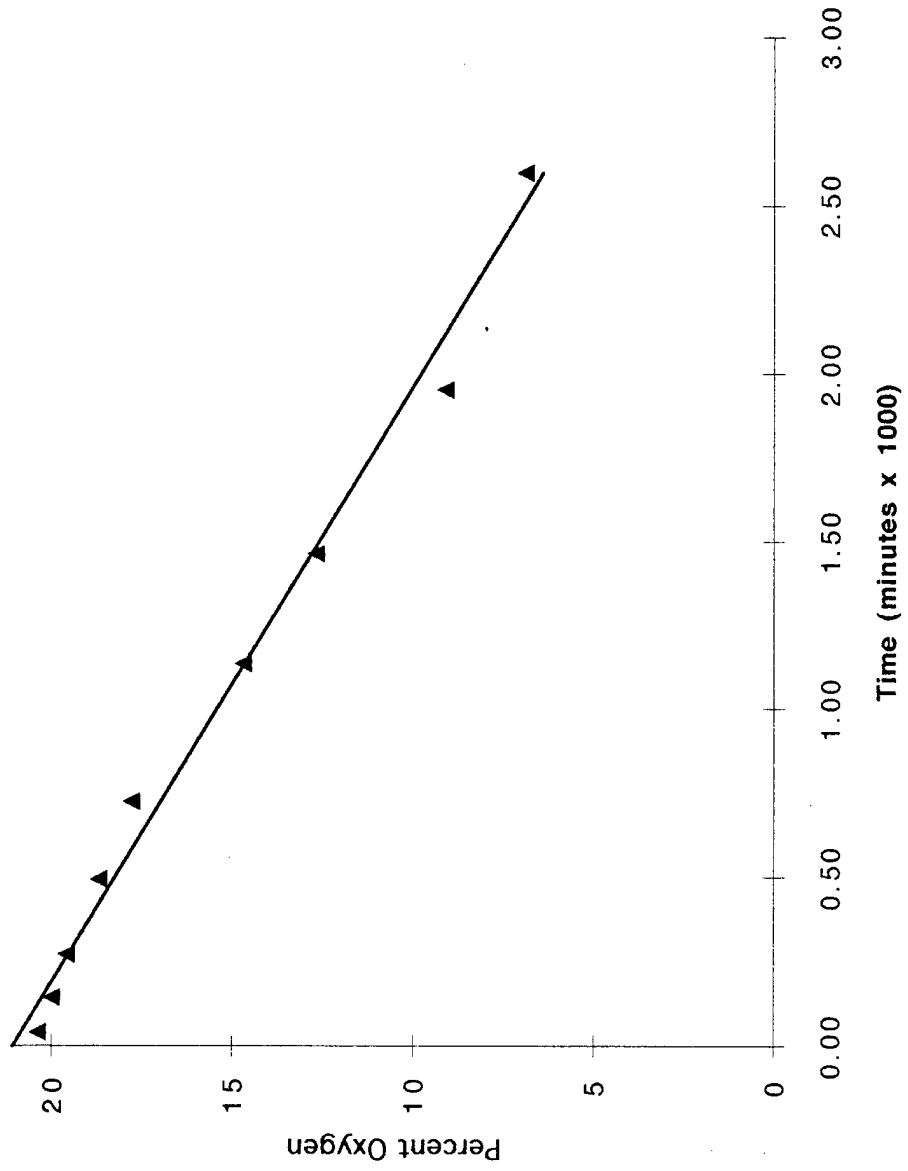

TABLE 3.4
OXYGEN UTILIZATION RATES
SWMU #70
CANNON AFB, NEW MEXICO

Location	O ₂ Loss ^{a/} (%)	Test ^{b/} Duration (min)	O ₂ Utilization ^{c/} Rate (%/min)
MPA-5	20.2	1,940	0.013
MPA-25	20.2	1,940	0.014
MPA-50	20.7	3,220	0.0078
MPA-70	14.6	4,050	0.0039
MPB-50	16.6	4,060	0.0056

^{a/} Actual measured oxygen loss (Difference between original %O₂ and final %O₂).

^{b/} Elapsed time from beginning of test to time when minimum oxygen concentration was measured.

^{c/} Values based on best-fit lines (Figures 3.1 through 3.4).

3.5 Potential Air Emissions

The long-term potential for air emissions from full-scale bioventing operations at this site is low because of the very low air injection flow rate (15 scfm) and the higher permeability of the deeper soils as compared to shallow soils. The majority of the injected air is flowing through soils below 25 feet bgs. Accumulated vapors will move slowly outward from the air injection VW, and vapor-phase hydrocarbons will be biodegraded as they move horizontally through the soil.

4.0 FACILITY 187

Soil gas sampling was performed at Facility 187 in December 1993. At that time, soil gas was sampled by withdrawing soil gas from the two 6-inch PVC perforated pipes installed in the dispenser island. Soil gas oxygen concentrations were not oxygen deficient. During pilot testing activities at SWMU #70, additional soil gas sampling was performed at Facility 187. Soil gas probes were driven into the soil at the bottom of the two, 6-inch PVC pipes. A probe was driven approximately 20 inches below the bottom of the southern pipe. Soil gas withdrawn from this location contained 18 percent oxygen and approximately 40 ppmv TVH. The probe could not be driven any deeper at this location. A probe was driven approximately 36 inches deep into the soil at the bottom of the northern PVC pipe. Soil gas withdrawn from this location contained 15 percent oxygen and 51 ppmv TVH. Based on the measured oxygen concentrations, it appears that soils beneath the dispenser are not oxygen depleted and that bioventing would not enhance degradation of petroleum hydrocarbons beneath the dispenser.

5.0 RECOMMENDATIONS

Initial bioventing tests at SWMU #70-Oil/Water Separator No. 326 at Cannon AFB indicate that oxygen has been depleted in the contaminated soils, and that air injection is an effective method of increasing aerobic fuel biodegradation. AFCEE recommends that air injection continue at this site to determine the long-term radius of oxygen influence and the effect of time, available nutrients, and changing temperatures on fuel biodegradation rates.

A small, 1-horsepower regenerative blower has been installed at the site to continue air injection at a rate of approximately 15 scfm. The blower system was started on May 15, 1994. In November 1994, ES will return to the site to sample and analyze the soil gas and conduct a repeat respiration test. In June 1995, a final respiration test will be conducted, and soil and soil gas samples will be collected from the site to determine the degree of remediation achieved during the first year of *in situ* treatment. Based on the results of the first year of pilot-scale bioventing, AFCEE will recommend one of three options:

- Continue operation of the bioventing system for full-scale remediation of the site. Based on soil sampling results, the existing system is providing oxygen throughout the entire contaminated soil volume. AFCEE can assist the base in obtaining regulatory approval for continued operation; or
- If final soil sampling indicates significant contaminant removal has occurred, AFCEE may recommend additional sampling to confirm that cleanup criteria have been achieved; or

- If significant difficulties or poor results are encountered during bioventing at this site, AFCEE may recommend removal of the blower system.

6.0 REFERENCES

- Hinchee, R.E., S.K. Ong., R.N. Miller, D.C. Downey, and R. Frandt. 1992. *Test Plan and Technical Protocol for a Field Treatability Test for Bioventing*. Prepared for USAF Center for Environmental Excellence. May.
- Johnson, P.C., M.W. Kemblowski, and J.D. Colthart. 1990. "Quantitative Analysis for the Cleanup of Hydrocarbon-Contaminated Soils by In-Situ Soil Venting." *Ground Water* 28(3). May-June.

APPENDIX A

SOIL SAMPLING LETTER

ADDENDUM TO THE WORK PLAN

January 25, 1994

Mr. John Ekhoﬀ
27 CES
111 Engineers Way
Cannon AFB, NM 88103-5136

Re: Proposed Soil Sampling Procedures at SWMU #70 Bioventing Pilot Test Site

Dear Mr. Ekhoﬀ:

The purpose of this letter is to clarify the soil sampling procedures that will be used during drilling activities at Cannon Air Force Base (AFB). The drilling will be performed to install components of the bioventing pilot testing system. The purpose of the pilot test activities planned for the SWMU #70 site are to assess the potential for bioventing as a remedial alternative at this site. While some site investigation data will be gathered during the pilot testing activities, site characterization is not a primary goal of the pilot test.

Because the depth of soil contamination remains unknown, Engineering-Science, Inc. (ES) proposes the following soil sampling procedures. If approved, these procedures will be considered an addendum to the *Draft Bioventing Pilot Test Work Plan for SWMU #70 - Oil/Water Separator, Cannon AFB, New Mexico, January, 1994* (Work Plan).

During installation of the first boring (at the location of the proposed vent well) soil sampling will be performed as follows:

- Drill cuttings will be screened with a portable total volatile hydrocarbon (TVH) analyzer approximately every 5 feet and the results will be reported on the boring log.
- One soil sample will be collected every 10 feet, beginning at 10 feet below ground surface (bgs) and continuing to the bottom of the boring.
- Soil samples will be stored at 4 degrees Celsius in brass liners covered with Teflon sheets and plastic end caps.
- A portion of each soil sample will be placed in a sealable plastic bag, be set in a warm location and allowed to equilibrate for at least 10 minutes and a headspace reading will be collected using a portable TVH analyzer.

Mr. John Ekhoﬀ
January 25, 1994
Page 2

- One brass liner from each sampling interval will be properly labeled, packaged, and sent to the laboratory for analysis of benzene, toluene, ethylbenzene, and xylenes (BTEX) by method SW8020 and total recoverable petroleum hydrocarbons (TRPH) by EPA Method 418.1. These analytes are the typical analyses performed under the AFCEE bioventing program. EPA Region 6 approved the use of these analytes for bioventing pilot tests at Kirkland AFB in April 1993.
- The most contaminated soil sample, based on the headspace readings obtained will be properly labeled, packaged, and sent to the laboratory for analysis of all the analytes described in the Work Plan (BTEX, TRPH, soil moisture, pH, grain size analysis, alkalinity, total iron, and nutrients).

Based on the total depth of the vent well the site manager may determine that two rather than three monitoring points will be constructed. This deviation from the work plan would facilitate increased soil sampling of two monitoring points with consideration for budget and schedule constraints. During installation of the monitoring points, soil sampling will be performed as follows:

- Drill cuttings will be screened with a portable total volatile hydrocarbon (TVH) analyzer approximately every 5 feet and the results will be reported on the boring log.
- Samples will be collected at the location of the monitoring point screened intervals (a minimum of three and a maximum of five screened intervals will be installed). The depths of the screened intervals will be determined by the field manager but will coincide with contaminated soils.
- Soil samples will be stored at 4 degrees Celsius in brass liners covered with Teflon sheets and plastic end caps.
- A portion of each soil sample will be placed in a sealable plastic bag, be set in a warm location and allowed to equilibrate for at least 10 minutes and a headspace reading will be collected using a portable TVH analyzer.
- One brass liner from each sampling interval will be properly labeled, packaged, and sent to the laboratory for analysis of BTEX by method SW8020 and TRPH by EPA Method 418.1.
- At the discretion of the site manager, one sample will be selected for analysis of all the analytes described in the Work Plan.

The total depth of the vent well and monitoring point boreholes will be dependant on the depth of contamination in the vent well boring based on field instrument readings. The boreholes will be completed to a minimum of 60 feet bgs, the known depth of contamination. The vent well borehole will continue beyond 60 feet bgs until soil samples from two consecutive 10 foot intervals produce headspace readings of less

Mr. John Ekhoﬀ
January 25, 1994
Page 3

than 20 parts per million volume per volume (ppmv) or until ground water is encountered. The 20 ppmv level was chosen because soil moisture alone will frequently cause 0 to 20 ppmv detections on the TVH analyzer. The total depth of the monitoring point boreholes will be approximately 5 feet less than the total depth of the vent well screen. If the vent well extends into the groundwater the total depth of the monitoring points will be approximately 10 feet above the ground water surface.

We look forward to working with you on this exciting project. Please call me or Doug Downey at (303) 831-8100 if you have any questions.

Sincerely,

ENGINEERING-SCIENCE, INC.

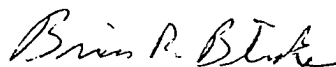

Brian R. Blicher
Site Manager

cc: Mr. Patrick Haas, AFCEE/ESRX
File 722408.52C

APPENDIX B

GEOLOGIC BORING LOGS

GEOLOGIC BORING LOG

JOB NO.:	722408.5205	CLIENT:	AFCEE/CANNON AFB	DATE:	5/3/94 TO 5/4/94
BORING NO.:	CA1-VW	BORING DIA.:	9.5 INCHES O.D.	ELEV.:	APPROX 4,000 FEET
RIG TYPE:	DWP-1200 T40K	CONTRACTOR:	BEYLIK	GEOLOGIST:	BRB/DEM
DRILLING MEDIUM:	AIR	DRLG METHOD:	DUAL WALL PERCUSSION	TEMP.:	APPROX 70°F

Depth (ft)	Pro-file	USCS	Geologic Description	Sample		Sample Type	Blow Counts	Remarks TIP = Bkgrnd/Reading (ppm)
				No.	Depth (ft)			
								Samples driven with 140 lb hammer unless otherwise noted.
5		ML-	SILT, sm sand, mod brn 5YR 4/4, dry	CA1-VW-5	5	G		1.8/3.2
10			CLAYEY SILT, sm sand, mod brn 5 YR 3/4, moist	CA1-VW-10	9 - 11	D	17/11 11/12	1.4/approx. 200 07:32
15			SANDY SILT, pale yellowish brn 10 YR 6/2	CA1-VW-15	15	G		1.4/approx 320
20		SM-SC	VF SAND, w clay & silt, mod brn 5 YR 4/4	CA1-VW-20	19 - 21	D	1/2 6/17	1.4/approx. 380 08:01
25			CLAYEY F SAND, sm silt, dk yellowish brn 10 YR 4/2	CA1-VW-25	25	G		1.1/approx. 160 Borehole hydrated to improve recovery
30			VF SAND, sm silt and clay, mod brn 5 YR 3/4	CA1-VW-30	29 - 31	D	11/34 34/38	1.1/approx. 150 09:33
35		SM	VF SAND, sm silt, w layers of caliche, lt brn 5 YR 6/4, stained	CA1-VW-35	35	G		1.1/approx. 50 Borehole hydrated to improve recovery
40			VF SAND, sm silt, dk yellowish brn 10 yr 4/2, stained	CA1-VW-40	39 - 41	D	1/1/4/8	1.1/approx. 250, 10:15 Poor recovery (<50%)

tr - trace	lt - light	c - coarse	@ - at	brn - brown
SAA - Same As Above	med - medium	f - fine	v - very	blk - black
sm - some	gr - grained	vf - very fine	dk - dark	mod - moderate
dia - diameter	w - with	& - and	sl - slightly	

GEOLOGIC BORING LOG

JOB NO.:	722408.5205	CLIENT:	AFCEE/CANNON AFB	DATE: 5/3/94 TO 5/4/94
BORING NO.:	CA1-VW	BORING DIA.:	9.5 INCHES O.D.	ELEV: APPROX 4,000 FEET
RIG TYPE:	DWP-1200 T40K	CONTRACTOR:	BEYLIK	GEOLOG: BRB/DEM
DRILLING MEDIUM:	AIR	DRLG METHOD:	DUAL WALL PERCUSSION	TEMP: APPROX 70°F

Depth (ft)	Pro-- file	USCS	Geologic Description	Sample		Sample Type	Blow Counts	Remarks TIP = Bkgrnd/Reading (ppm)
				No.	Depth (ft)			
45		SM	VF SAND & SILT, w layers of caliche, lt brn 5 YR 5/6,	CA1-VW-45	45	G	1.8/approx. 70	Boring hydrated to improve recovery
50			F SAND, tr m sand, lt brn 5 YR 6/4, calcarious, cemented	CA1-VW-50	49 - 51	D	1/1 2/3	10:35 poor recovery (<50%) 1.8/approx. 160
55			F SAND & SILT, mod brn 5 YR 4/4, layers of caliche	CA1-VW-55	55	G		1.0/approx 60 Boring hydrated to improve recovery
60			F SAND & SILT, tr m sand, lt brn 5 YR 5/6	CA1-VW-60	59 - 61	D	3/4 7/8	11:15 1.0/approx. 90
65		SM	F SAND & SILT, w layers of caliche, lt brn 5 YR 6/4	CA1-VW-65	65	G		1.5/approx. 31 Boring hydrated to improve recovery
70			F SAND & SILT, lt brn 5 YR 6/4	CA1-VW-70	69 - 71	D	2/8 11/11	11:46 1.3/10
75			SP	M SAND, sm sandstone, lt brn 5 YR 5/6 lt brn 5 YR 6/4, stained	CA1-VW-75	75	G	
80		F-M SAND, lt brn 5 YR 6/4		CA1-VW-80	79 - 81	D	1/2/2/2	12:59, 0/36

tr - trace	lt - light	c - coarse	@ - at	brn - brown
SAA - Same As Above	med - medium	f - fine	v - very	blk - black
sm - some	gr - grained	vf - very fine	dk - dark	mod - moderate
dia - diameter	w - with	& - and		sl - slightly

GEOLOGIC BORING LOG

JOB NO.:	722408.5205	CLIENT:	AFCEE/CANNON AFB	DATE:	5/3/94 TO 5/4/94
BORING NO.:	CA1-VW	BORING DIA.:	9.5 INCHES O.D.	ELEV.:	APPROX 4,000 FEET
RIG TYPE:	DWP-1200 T40K	CONTRACTOR:	BEYLIK	GEOLOGIST:	BRB/DEM
DRILLING MEDIUM:	AIR	DRLG METHOD:	DUAL WALL PERCUSSION	TEMP.:	APPROX 70°F

Depth (ft)	Pro-file	USCS	Geologic Description	Sample		Sample Type	Blow Counts	Remarks TIP = Bkgrnd/Reading (ppm)
				No.	Depth (ft)			
85			F-M SAND, sm sandstone, mod brn 5 YR 3/4	CA1-VW-85	85	G		1.6/2.0
90			F SAND, sm sandstone, lt brn 5 yr 5/6	CA1-VW-90	89 - 91	D	1/2 6/24	14:30, 60 % recovery, lt odor 1.3/78
95		SP	F SAND, sm sandstone, lt brn 5 yr 5/6	CA1-VW-95	95	G		Formation becomes more consolidated below 94 feet. 1.6/10.8
100			F-M SAND, lt brn 5 YR 5/6	CA1-VW-100	99 - 101	D	1/24 36/42	14:48, poor recovery 1.6/2.7
105			F-M SAND & SANDSTONE, lt brn, 5 YR 5/6	CA1-VW-105	105	G		1.6/1.8 Boring hydrated to improve recovery
110			F-M SAND & SANDSTONE, lt brn, 5 YR 5/6	CA1-VW-110	109 - 110	D	2/4 4/4	15:20, poor recovery 1.3/9.4
			TD = 112 feet					
115								
120								

tr - trace	lt - light	c - coarse	@ - at	brn - brown
SAA - Same As Above	med - medium	f - fine	v - very	blk - black
sm - some	gr - grained	vf - very fine	dk - dark	mod - moderate
dia - diameter	w - with	& - and		sl - slightly

GEOLOGIC BORING LOG

JOB NO.:	722408.5205	CLIENT:	AFCEE/CANNON AFB
BORING NO.:	CA1-MPA	BORING DIA.:	9.5 INCHES O.D.
RIG TYPE:	DWP-1200 T40K	CONTRACTOR:	BEYLIK
DRILLING MEDIUM:	AIR	DRLG METHOD:	DUAL WALL PERCUSSION
		DATE:	5/5/94 TO 5/6/94
		ELEV:	APPROX 4,000 FEET
		GEOL:	BRB/DEM
		TEMP:	APPROX 70°F

Depth (ft)	Pro-file	USCS	Geologic Description	Sample		Sample Type	Blow Counts	Remarks TIP = Bkgrnd/Reading (ppm)
				No.	Depth (ft)			
5		ML	SANDY SILT, mod brn 5 YR 4/4, stained	CA1-MPA-5	4-6	D	22/32 38/42	17:05 95 ppm
10		GM-GC	GRAVEL AND COBBLES, sm clay & silt, grossly stained, v strong odor	CA1-MPA-9	9-10	G		17:40, appears to be leach well 175 ppm
15		ML	SILT & F SAND, grayish orange pink 5 YR 7/2 and v lt grey N8, strong odor	CA1-MPA-15	14-15	D	4/8	18:03, heavily contaminated Approx. 400 ppm
20		SM	F SAND, sm silt & clay, mod yellowish brn 10 YR 5/4 stained, strong odor	CA1-MPA-20	19-21	D	4/23 24/28	07:56 360 ppm
25		SM-SC	F SAND, sm silt and clay, lt brnish gray 5 YR 6/1 stained, strong odor	CA1-MPA-25	25	G		190 ppm Borehole hydrated to improve recovery
30		SM	F SAND, sm silt & clay, sm gravel, mod brn 5 YR 4/4 stained, strong odor	CA1-MPA-30	29-31	D	8/16 24/32	08:35 180 ppm
35		SM	F SAND & SILT, w layers of caliche, mod brn 5 YR 4/4 strong odor	CA1-MPA-35	35	G		240 ppm Borehole hydrated to improve recovery
40		SM	F SAND & SILT, well consolidated, hard, mod brn 5 YR 4/4, hydrocarbon odor	CA1-MPA-40	39-41	D		09:15, poor recovery (30%) 237 ppm

tr - trace	lt - light	c - coarse	@ - at	brn - brown
SAA - Same As Above	med - medium	f - fine	v - very	blk - black
sm - some	gr - grained	vf - very fine	dk - dark	mod - moderate
dia - diameter	w - with	& - and	sl - slightly	

GEOLOGIC BORING LOG

JOB NO.:	722408.5205	CLIENT:	AFCEE/CANNON AFB	DATE: 5/5/94 TO 5/6/94
BORING NO.:	CA1-MPA	BORING DIA.:	9.5 INCHES O.D.	ELEV: APPROX 4,000 FEET
RIG TYPE:	DWP-1200 T40K	CONTRACTOR:	BEYLIK	GEOLOG: BRB/DEM
DRILLING MEDIUM:	AIR	DRLG METHOD:	DUAL WALL PERCUSSION	TEMP: APPROX 70°F

Depth (ft)	Pro-file	USCS	Geologic Description	Sample		Sample Type	Blow Counts	Remarks TIP = Bkgrnd/Reading (ppm)	
				No.	Depth (ft)				
45		SM							
			F SAND & SILT, sm sand & siltstone, mod brn 5 YR 4/4, strong odor	CA1-MPA-46	46	G		Approx. 250 ppm	
50			F SAND & SILT, w layers of caliche, mod brn 5 yr 4/4	CA1-MPA-50	49 - 49.5	D	52	09:40, poor recovery 220 ppm	
55			F SAND & SILT, layers of caliche, lt brn 5 YR 5/6	CA1-MPA-55	55	G		Approx. 200 ppm	
60			F SAND & SILT, layers of caliche, lt brn 5 YR 6/4	CA1-MPA-60	59 - 59.5	D	52	10:05, poor recovery Too little sample for headspace	
65			F SAND & SILT, w layers of caliche, lt brn 5 YR 6/4	CA1-MPA-65	65	G		Approx. 220 ppm recovery	
70		SP	F SAND, sm m sand w/ layers of caliche, pale yellowish brn 10 YR 6/2, strong odor	CA1-MPA-70	69 - 70	D	NA	10:31, poor recovery (50%), Sampled using 1000 lb hammer 210 ppm	
75				SAND & SANDSTONE, lt brn 5 YR 6/4	CA1-MPA-75	75	G		-3.0/approx. 320 ppm
									10:50, poor recovery w 1000 lb Duplicate labeled MPA-140
80			F-M SAND, mod brn, 5 YR 4/4, slight odor	VW-80	79 - 80	D	NA	collected, -3.5/12.0 ppm	

tr - trace	lt - light	c - coarse	@ - at	brn - brown
SAA - Same As Above	med - medium	f - fine	v - very	blk - black
sm - some	gr - grained	vf - very fine	dk - dark	mod - moderate
dia - diameter	w - with	& - and	sl - slightly	

GEOLOGIC BORING LOG

JOB NO.:	722408.5205	CLIENT:	AFCEE/CANNON AFB	DATE:	5/5/94 TO 5/6/94
BORING NO.:	CA1-MPA	BORING DIA.:	9.5 INCHES O.D.	ELEV.:	APPROX 4,000 FEET
RIG TYPE:	DWP-1200 T40K	CONTRACTOR:	BEYLIK	GEOL.:	BRB/DEM
DRILLING MEDIUM:	AIR	DRLG METHOD:	DUAL WALL PERCUSSION	TEMP.:	APPROX 70°F

Depth (ft)	Pro-file	USCS	Geologic Description	Sample		Sample Type	Blow Counts	Remarks TIP = Bkgrnd/Reading (ppm)
				No.	Depth (ft)			
85			SAND & SANDSTONE, mod brn 5 YR 4/4	CA1-MPA-85	85	G		-3.5/approx. 12
90			F SAND, sm sandstone, lt brn 5 yr 5/6	CA1-MPA-90	89 - 90	D	NA	11:08, sample w 1000 lb hammer, poor recovery, -3.5/approx.39
95		SP	F SAND, sm sandstone, lt brn 5 yr 5/6	CA1-MPA-95	95	G		-7.9/-8.2
100			F-M SAND, sm sandstone, lt brn 5 YR 5/6	CA1-MPA-100	99 - 101	D	2/8 12/24	12:35 -7.9/-5.0
105			Perched water w foul odor from 102 feet to 106 feet.					-9.1/approx. 150 Thin mud consistency
110			F SAND & SANDSTONE	CA1-MPA-110	109 - 109.5 110 - 110.5	D D		13:25, poor recovery, -9.1/-5 13:35, poor recovery, -10.0/-12.0
115		SM	F SAND, sm silt, lt br 5 YR 5/6	CA1-MPA-116	115	G		-10.0/-9.8
120			F SAND & SILT, lt brn 5 YR 6/4. TD = 123 feet	CA1-MPA-120	119 - 121	D		14:02, -10.0/-10.3

tr - trace	lt - light	c - coarse	@ - at	brn - brown
SAA - Same As Above	med - medium	f - fine	v - very	blk - black
sm - some	gr - grained	vf - very fine	dk - dark	mod - moderate
dia - diameter	w - with	& - and		sl - slightly

GEOLOGIC BORING LOG

JOB NO.:	722408.52050	CLIENT:	AFCEE/CANNON AFB	DATE:	5/7/94
BORING NO.:	CA1-MPB	BORING DIA.:	9.5 INCHES O.D.	ELEV.:	APPROX 4,000 FEET
RIG TYPE:	DWP-1200 T40K	CONTRACTOR:	BEYLIK	GEOL.:	BRB/DEM
DRILLING MEDIUM:	AIR	DRLG METHOD:	DUAL WALL PERCUSSION	TEMP.:	APPROX 70°F

Depth (ft)	Pro-file	USCS	Geologic Description	Sample		Sample Type	Blow Counts	Remarks TIP = Bkgrnd/Reading (ppm)
				No.	Depth (ft)			
								* All driven soil samples were with a 1000 lb hammer.
5		ML-CL	SILTY CLAY, v hard, mod brn 5 YR 3/4, dry	CA1-MPB-5	4 - 6	D	NA*	12:57 -0.9/-1.2
10			SILTY CLAY, v hard, mod brn 5 YR 4/4	CA1-MPB-10	10	G		
15		ML-CL	SILT, w f sand, mod brn 5 YR 4/4, dry, sm staining hydrocarbon odor	CA1-MPB-15	14 - 16	D	NA	13:20 -0.9/approx. 300
20			F SAND, sm silt & clay, lt brn 5 YR 6/4	CA1-MPB-20	20	G		160 ppm
25		SM-SC	F SAND, sm silt and clay, mod brn 5 YR 4/4, firm strong odor	CA1-MPB-25	24 - 26	D	NA	13:37 -0.9/136, -0.9/232 resample
30			F SAND, sm silt & clay, layers of caliche, lt brn 5 YR 5/6, hydrocarbon odor	CA1-MPB-30	30	G		299 ppm
35		SM	F SAND & SILT, v pale orange 10 YR 8/2	CA1-MPB-35	34 - 36	D	NA	13:55, color change @ 35 feet 337 ppm
40			F-M SAND, sm silt mod brn 5 YR 4/4, dry, str. odor	CA1-MPB-40	40	G		331 ppm

tr - trace	lt - light	c - coarse	@ - at	brn - brown
SAA - Same As Above	med - medium	f - fine	v - very	blk - black
sm - some	gr - grained	vf - very fine	dk - dark	mod - moderate
dia - diameter	w - with	& - and		sl - slightly

GEOLOGIC BORING LOG

JOB NO.:	722408.5205	CLIENT:	AFCEE/CANNON AFB	DATE:	5/7/94
BORING NO.:	CA1-MPB	BORING DIA.:	9.5 INCHES O.D.	ELEV.:	APPROX 4,000 FEET
RIG TYPE:	DWP-1200 T40K	CONTRACTOR:	BEYLIK	GEOL.:	BRB/DEM
DRILLING MEDIUM:	AIR	DRLG METHOD:	DUAL WALL PERCUSSION	TEMP.:	APPROX 70°F

Depth (ft)	Pro-- file	USCS	Geologic Description	Sample		Sample Type	Blow Counts	Remarks TIP = Bkgrnd/Reading (ppm)
				No.	Depth (ft)			
45		SM	F SAND & SILT, sm sandstone, lt brn 5 YR 5/6	CA1-MPB-45	45	G		443 ppm
50			F SAND & SILT, w layers of caliche, lt brn 5 yr 6/4 hard	CA1-MPB-50	49 - 50	D	NA	14:32, poor recovery Approx. 450 ppm
55			V F SAND & SILT, sm caliche, grayish orange pink 5 YR 7/2	CA1-MPB-55	55	G		245 ppm
60		SM	F SAND & SILT, layers of caliche, lt brn 5 YR 5/6	CA1-MPB-60	59 - 60	D	NA	15:03, poor recovery Approx. 550 ppm
65			F SAND & SILT, w layers sand and siltstone, lt brn 5 YR 5/6	CA1-MPB-65	65	G		25 ppm
70			M-F SAND, lt brn 5 YR 5/6	CA1-MPB-70	69 - 71	D	NA	15:53 13 ppm
75		SP	M-F SAND, lt brn 5 YR 5/6, sl odor	CA1-MPB-75	75	G		10 ppm
80			F-M SAND & SANDSTONE, lt brn 5 YR 5/6, sl odor	CA1-MPB-80	80	G		8 ppm

tr - trace	lt - light	c - coarse	@ - at	brn - brown
SAA - Same As Above	med - medium	f - fine	v - very	blk - black
sm - some	gr - grained	vf - very fine	dk - dark	mod - moderate
dia - diameter	w - with	& - and	sl - slightly	

GEOLOGIC BORING LOG

JOB NO.:	722408.5205	CLIENT:	AFCEE/CANNON AFB	DATE:	05/07/94
BORING NO.:	CA1-MPB	BORING DIA.:	9.5 INCHES O.D.	ELEV.:	APPROX 4,000 FEET
RIG TYPE:	DWP-1200 T40K	CONTRACTOR:	BEYLIK	GEOL.:	BRB/DEM
DRILLING MEDIUM:	AIR	DRLG METHOD:	DUAL TUBE PERCUSSION	TEMP.:	APPROX 70°F

Depth (ft)	Pro-file	USCS	Geologic Description	Sample		Sample Type	Blow Counts	Remarks TIP = Bkgrnd/Reading (ppm)
				No.	Depth (ft)			
85			F SAND, sm sandstone, lt brn, 5 YR 5/6	CA1-MPB-85	84-86	D	NA	16:23 39 ppmv
90			F SAND and sandstone, lt brn 5 YR 6/4, no order	CA1-MPB-90	90	G		8 ppmv
95		SP	F SAND, lt brn, 5 YR 5/6	CA1-MPB-95	94-96	D	NA	16:42 11 ppmv
100			V FINE SAND, lt brn, 5 YR 6/4	CA1-MPB-100	100	G		7 ppmv
105			F SAND, lt brn 5 YR 5/6	CA1-MPB-105	105	G		8 ppmv
			Encounter hard material					
110			F SAND, tr sandstone, lt brn, 5 yr 6/4, slight odor	CA1-MPB-110	109-111	D	NA	17:15 46 ppmv
			TD=112 feet					
115								
120								

tr - trace	lt - light	c - coarse	@ - at	brn - brown
SAA - Same As Above	med - medium	f - fine	v - very	blk - black
sm - some	gr - grained	vf - very fine	dk - dark	mod - moderate
dia - diameter	w - with	& - and		sl - slightly

ENGINEERING-SCIENCE

GEOLOGIC BORING LOG

JOB NO.:	722408.5205	CLIENT:	AFCEE/CANNON AFB
BORING NO.:	CA1-MPC	BORING DIA.:	9.5 INCHES O.D.
RIG TYPE:	DWP-1200 T40K	CONTRACTOR:	BEYLIK
DRILLING MEDIUM:	AIR	DRLG METHOD:	DUAL WALL PERCUSSION
			DATE: 5/8/94 TO 5/9/94
			ELEV: APPROX 4,000 FEET
			GEOL: BRB/DEM
			TEMP: APPROX 70°F

Depth (ft)	Pro-file	USCS	Geologic Description	Sample		Sample Type	Blow Counts	Remarks TIP = Bkgrnd/Reading (ppm)
				No.	Depth (ft)			
5		ML-CL	SILTY CLAY, v hard and dry, dk yellowish brn 10 YR 4/2 to ~ 5/SILT, sm f sand, v hard and dry, lt brn 5 YR 5/6, no odor or staining	CA1-MPC-5	4-6	D	NA	Poor recovery 1445 -3.7/-7.6
10								
15		ML-CL	SILT, w sm f sand, hard, layers of caliche, moderate orange-pink, 5 YR 8/4 to 15'/lt brn 5 YR 5/6 below 15, no odor	CA1-MPC-15	14-16	D	NA	15:03 -2.7/-7.6
20								
25		SM-SC	F SAND, sm silt and clay, and caliche lt br 5 YR 6/4, no odor	CA1-MPC-20	20	G		
25				F SAND, silt and clay, sm caliche lt brn 5 YR 5/6, no odor	CA1-MPC-25	24-26	D	NA
30		SM-SC	VF SAND, sm silt and clay, lt brn, 5 YR 6/4, dry, loose, no odor	CA1-MPC-30	30	G		-8.3/3.3
35								
35		SM	F SAND & SILT, lt brn 5 YR 6/4, no odor, dry	CA1-MPC-35	34-35	D	NA	15:55 poor recovery -9.0/-8.0
40				F SAND & SILT, tr m sand, lt brn, 5 YR 6/4, dry	CA1-MPC-40	40	G	

tr - trace	lt - light	c - coarse	@ - at	brn - brown
SAA - Same As Above	med - medium	f - fine	v - very	blk - black
sm - some	gr - grained	vf - very fine	dk - dark	mod - moderate
dia - diameter	w - with	& - and		sl - slightly

ENGINEERING-SCIENCE

GEOLOGIC BORING LOG

JOB NO.:	722408.5205	CLIENT:	AFCEE/CANNON AFB	DATE:	5/8/94 TO 5/9/94
BORING NO.:	CA1-MPC	BORING DIA.:	9.5 INCHES O.D.	ELEV.:	APPROX 4,000 FEET
RIG TYPE:	DWP-1200 T40K	CONTRACTOR:	BEYLIK	GEOL.:	BRB/DEM
DRILLING MEDIUM:	AIR	DRLG METHOD:	DUAL WALL PERCUSSION	TEMP.:	APPROX 70°F

Depth (ft)	Pro-file	USCS	Geologic Description	Sample		Sample Type	Blow Counts	Remarks TIP = Bkgrnd/Reading (ppm)
				No.	Depth (ft)			
45		SM	F SAND & SILT, sm m sand, lt brn 5 YR 6/4,0 no odor, dry	CA1-MPC-45	45	G		-7.7/-4.7
50			F SAND & SILT, sm m sand, layers of caliche, lt brn 5 YR 5/6, dry, no odor	CA1-MPC-50	49-51	D	NA	1627 -9.0/-7.3
55			VF SAND & SILT, sm m sand, sm caliche, lt brn, 5 yr 6/4, dry, no odor	CA1-MPC-55	55	G		-9.0/2.0
60		SP	F SAND, tr m sand, lt brn 5 YR 5/6, layers of caliche, no odor	CA1-MPC-60	59-60	D	NA	1647 poor recovery -8.6/-8.0
65			VF SAND, tr m sand, and caliche, dry, loose, lt brn 5 YR 6/4, no odor	CA1-MPC-65	65	G		-9.3/14.0
70			M to F SAND, w caliche, lt brn 5 YR 6/4, no odor	CA1-MPC-70	69-71	D	NA	17:13 2.3/-1.0
75			Not available					
80			M to F SAND, lt brn 5 YR 6/4, dry, loose, no odor	CA1-MPC-80	80	G		2.7/-3.3

tr - trace	lt - light	c - coarse	@ - at	brn - brown
SAA - Same As Above	med - medium	f - fine	v - very	blk - black
sm - some	gr - grained	vf - very fine	dk - dark	mod - moderate
dia - diameter	w - with	& - and		sl - slightly

ENGINEERING-SCIENCE

GEOLOGIC BORING LOG

JOB NO.:	722408.5205	CLIENT:	AFCEE/CANNON AFB	DATE:	5/8/94 TO 5/9/94
BORING NO.:	CA1-MPC	BORING DIA.:	9.5 INCHES O.D.	ELEV.:	APPROX 4,000 FEET
RIG TYPE:	DWP-1200 T40K	CONTRACTOR:	BEYLIK	GEOL.:	BRB/DEM
DRILLING MEDIUM:	AIR	DRLG METHOD:	DUAL WALL PERCUSSION	TEMP.:	APPROX 70°F

Depth (ft)	Pro-file	USCS	Geologic Description	Sample		Sample Type	Blow Counts	Remarks TIP = Bkgrnd/Reading (ppm)
				No.	Depth (ft)			
85		SP	F SAND, sm m sand, sm sandstone, lt brn 5 YR 6/4, no odor	CA1-MPC-85	84.5	D	NA	1727, very poor recovery 1.3/-3.0 (baggie)
90			F SAND, loose, lt brn 5 YR 6/4, no odor	CA1-MPC-90	90	G		0.3/-5.0
95			F SAND, lt brn 5 YR 5/6, no odor	CA1-MPC-95	94-96	D	NA	1750 -0.3/-5.0
100			V F SAND, lt brn 5 YR 5/6, dry, loose	CA1-MPC-100	100	G		-0.3/-4.3
105			V F SAND, lt brn 5 YR 6/4, no odor	CA1-MPC-105	105	G		-2.0/-5.6
110			F SAND & SANDSTONE, lt brn 5 YR 6/4 TD=112 ft	CA1-MPC-110	109-110	D	NA	0854, 5-9-94 Poor recovery 1.0/-1.3
115								
120								

tr - trace	lt - light	c - coarse	@ - at	brn - brown
SAA - Same As Above	med - medium	f - fine	v - very	blk - black
sm - some	gr - grained	vf - very fine	dk - dark	mod - moderate
dia - diameter	w - with	& - and		sl - slightly

ENGINEERING-SCIENCE

GEOLOGIC BORING LOG

JOB NO.:	722408.52050	CLIENT:	AFCEE/CANNON AFB	DATE:	05/10/94
BORING NO.:	CA1-BG	BORING DIA.:	9.5 INCHES O.D.	ELEV.:	APPROX 4,000 FEET
RIG TYPE:	DWP-1200 T40K	CONTRACTOR:	BEYLIK	GEOL.:	BRB/DEM
DRILLING MEDIUM:	AIR	DRLG METHOD:	DUAL WALL PERCUSSION	TEMP.:	APPROX 70°F

Depth (ft)	Pro-file	USCS	Geologic Description	Sample		Sample Type	Blow Counts	Remarks TIP = Bkgrnd/Reading (ppm)
				No.	Depth (ft)			
5			F SAND, moderate brn 5 YR 4/4	CA1-BG-5	5	G		-1.2/-1.7
10								
15			V F SAND, lt brn 5 YR 6/4	CA1-BG-15	15	G		-2.7/-3.2
20			F SAND, lt brn 5 YR 5/6	CA1-BG-20	20	G		-1.2/-2.2
25			V F SAND & SILT, sm caliche, lt brn 5 YR 5/6 TO 26', mod brn 5 YR 4/4 below 26', no odor	CA1-BG-25	24-26	D	NA	08:37 -1.2/-3.2
30			F SAND & SILT, lt brn 5 YR 5/6 w clayey fine sand, mod brn 5 YR 4/4, no odor	CA1-BG-30	30	G		-1.5/-2.5
35								
40			F SAND & SILT, w tr caliche, lt brn 5 YR 5/6, no odor	CA1-BG-40	40	G		1.7/-2.5

tr - trace	lt - light	c - coarse	@ - at	brn - brown
SAA - Same As Above	med - medium	f - fine	v - very	blk - black
sm - some	gr - grained	vf - very fine	dk - dark	mod - moderate
dia - diameter	w - with	& - and		sl - slightly

ENGINEERING-SCIENCE

GEOLOGIC BORING LOG

JOB NO.:	722408.52050	CLIENT:	AFCEE/CANNON AFB	DATE:	05/10/94
BORING NO.:	CA1-BG	BORING DIA.:	9.5 INCHES O.D.	ELEV.:	APPROX 4,000 FEET
RIG TYPE:	DWP-1200 T40K	CONTRACTOR:	BEYLIK	GEOL.:	BRB/DEM
DRILLING MEDIUM:	AIR	DRLG METHOD:	DUAL WALL PERCUSSION	TEMP.:	APPROX 70°F

Depth (ft)	Pro-file	USCS	Geologic Description	Sample		Sample Type	Blow Counts	Remarks TIP = Bkgrnd/Reading (ppm)
				No.	Depth (ft)			
45		SM	F SAND & SILT, w tr caliche, lt brn 5 YR 5/6, no odor	CA1-BG-45	45	G		-2.7/-3.2
50			F SAND & SILT, sm caliche, lt brn 5 YR 6/4	CA1-BG-50	50	G		-2.5/-3.0
55								
60								
65								
70								
75								
80								

tr - trace	lt - light	c - coarse	@ - at	brn - brown
SAA - Same As Above	med - medium	f - fine	v - very	blk - black
sm - some	gr - grained	vf - very fine	dk - dark	mod - moderate
dia - diameter	w - with	& - and		sl - slightly

ENGINEERING-SCIENCE

APPENDIX C

O & M CHECKLIST

APPENDIX C

OPERATION AND MAINTENANCE INSTRUCTIONS

This appendix is intended to supplement the Interim Results Report, not to replace the operations and maintenance (O&M) manual provided to Cannon Air Force Base (AFB). Please refer to the O&M manual for more detail.

1.0 BLOWER/MOTOR MAINTENANCE

A 1-horsepower Gast® regenerative blower has been installed at the SWMU #70 site at Cannon AFB. The blower and motor are relatively maintenance free. There is no lubrication required because the blower and motor have sealed bearings. If a blower system is in need of repair, please contact Mr. Brian Blicher of Engineering-Science, Inc. (ES) in Denver, Colorado at (303) 831-8100.

2.0 FILTER MAINTENANCE

To avoid damage caused by passing solids through the blower, an air filter has been installed inline before the blower. Continuous ingestion of solids will damage or imbalance the impellers. The inline air filter will prevent solids from entering the blower and is rated at 99-percent efficiency to 10 microns.

The paper filter element is replaceable. The filter should be checked weekly for the first 2 months of operation. The air filter should be replaced when the pressure difference across the filter reaches 15 to 20 inches of water. It will be the responsibility of Cannon AFB personnel to determine the best schedule for filter replacement depending on the results of the initial observations.

The filter can be checked after turning off the blower system. To remove the filter, loosen the clamps, lift the metal top off of the air filter, and lift the air filter from the metal housing. When replacing the filter, be careful to ensure that the rubber seals remain in place. ES has provided Cannon AFB with a supply of air filters for the next year of blower operation. Should additional air filters be required, they can be ordered from Solberg Manufacturing, Inc. in Itasca, Illinois. Their phone number is (708) 773-1363. It is recommended that Cannon AFB keep a spare air filter at the site.

3.0 BLOWER PERFORMANCE MONITORING

To monitor the blower performance, vacuum, pressure, and temperature must be measured. These data should be recorded on the data collection sheets provided. All measurements will be taken at the same time while the system is running.

3.1 Pressure/Vacuum

Open the shed roof and record the pressure and vacuum readings directly from the gauges in inches of water. Pressure readings are necessary to determine design parameters, and to verify that the blower is operating correctly. Vacuum readings are necessary to assure that the filter is clean. Record the measurements on the data collection sheet provided.

3.2 Temperature

Open the shed roof and record the temperature readings directly from the gauges in degrees Fahrenheit (°F). Record the measurements on the data collection sheet provided. Temperature readings are necessary to verify that the blower is operating correctly. The temperature should remain relatively constant with time. Should the temperature rise substantially in a short period of time, a problem may exist within the blower. Ambient air temperature fluctuations will affect the temperature readings but the temperature rise across the blower should not vary by more than 20°F.

4.0 MONITORING SCHEDULE

The following monitoring schedule is recommended for this system. During the initial months of operation, more frequent monitoring is recommended to ensure that any start up problems are quickly corrected. Data collection sheets have been provided for use by Randolph AFB personnel during data collection.

<u>Monitoring Item</u>	<u>Monitoring Frequency</u>
Blower pressure, vacuum, and temperature	Weekly.
Filter change	As required. When vacuum across filter exceeds 15 inches of water

APPENDIX D

CHAIN OF CUSTODY FORMS

740510.506

CHAIN OF CUSTODY RECORD

ENGINEERING-SCIENCE, INC.
1700 BROADWAY, SUITE 900
DENVER, COLORADO 80290
303-831-8100

Base: *Cannon AFB*

Site: *CA1 (SWMU #70)*

ES Job No. 722403-52040
DE268. 5 2.08

AFCEE BIOVENTING PILOT TESTS

Sampler(s): (Signature) *David Montoya*
Brian Bieker

Date	Time	Sample Description	Lab I.D.	No. of Contrs.
5/5/94	1705	CA1-MPA-5		1
5/5/94	1740	CA1-MPA-9		1
5/6/94	0756	CA1-MPA-20		3
5/6/94	0835	CA1-MPA-30 *		2
5/6/94	0915	CA1-MPA-40		1
5/6/94	0940	CA1-MPA-50		1
5/6/94	1005	CA1-MPA-60		1
5/6/94	1031	CA1-MPA-70 *		2
5/6/94	1050	CA1-MPA-80		1
5/6/94	1108	CA1-MPA-90		1
5/6/94	1235	CA1-MPA-100		1
5/6/94	1325	CA1-MPA-110		1
5/6/94	1402	CA1-MPA-120		1
5/6/94	1440	CA1-MPA-130		1
5/6/94	1505	CA1-MPA-140		1
5/7/94	1257	CA1-MPB-5		1

Relinquished by: (Signature) *David Montoya* Date / Time *5/9/94 1700*

Relinquished by: (Signature) *VIA FED EX* Date / Time *5-10-94 0910*

Received for Laboratory by: (Signature) *VIA FED EX* Date / Time *5-9 1615*

Received for Laboratory by: (Signature) *PAE* Date / Time *5-10-94 0930*

Distribution: Original Accompanies Shipment. Copies to: Coordinator Field Files

Federal Express Number: *1968964244*

Airbill Number: _____

REAC 60c

GU

Ship To:

PACE INCORPORATED
5702 Bolsa Ave.
Huntington Beach, CA 92649

Attn: Melony Concepcion
(714) 892-2565

Sample Type	Matrix	Remarks
G C	SOIL	BTEX from 5 1/3 to 5 2/3 BGS
G C	SOIL	Collected from Cuttings
G C	SOIL	BTEX from 20 2/3 to 21'
G C	SOIL	BTEX from 30 1/3 to 30 2/3. Also analyzed for SVOCs (SW8270)
G C	SOIL	Poor recovery. Packed in 4oz jar
G C	SOIL	Poor recovery. Packed in 4oz jar
G C	SOIL	Also analyze for SVOCs (SW8270)
G C	SOIL	
G C	SOIL	
G C	SOIL	
G C	SOIL	
G C	SOIL	
G C	SOIL	collected from 130 2/3 to 131'
G C	SOIL	
G C	SOIL	4.5 to 5.0' BGS

Preservative: NONE

Analysis Required:

SW 9045 (PH)	
A 403 (ALKA)	X
SW 7380 (IRON)	
SW 846 (MOIST)	
SW 8020 (BTEX)	X
E 418.1 (TRPH)	
E 351.2 (TKN)	
E 365.3 (PHOS)	
UCM (CLASS)	

Hold AT 4C NONE

Remarks: ** Also analyze for semivolatile organics (SW8270)*

G - Grab Sample, C - Composite Sample



AIR TOXICS LTD.

AN ENVIRONMENTAL ANALYTICAL LABORATORY

180 BLUE RAVINE ROAD, SUITE B
FOLSOM, CA 95630
(916) 985-1000 • FAX (916) 985-1020

9405104

CHAIN OF CUSTODY RECORD

Page 1 of 1

PROJECT # 722408.52040 PO # 722408.52080 COLLECTED BY (Signature) Brian Blisk / David Mauter

REMARKS _____

FIELD SAMPLE I.D.#	SAMPLING MEDIA (Tenax, Canister etc.)	DATE/TIME	ANALYSIS	VAC./PRESSURE	LAB I.D.#
01A6	Summa # 9378 AT	5-11-94 / 20:10	T0-3 (TPH + BTX)	3.0" Hg	
02A6	Summa # 9373 AT	5-11-94 / 20:23	T0-3 (TPH + BTX)	4.0" Hg	
03A	Summa # 93111 AT	5-18-94 0847	T0-3 (TPH + BTX)	4.0" Hg	
04A	Summa # 9370 AT	5-15-94 / 09:10	T0-3 (TPH + BTX)	4.0" Hg	
	Also included is canister # 93418 AT which did not appear to draw a sample. Suspect insufficient vacuum.				

RELINQUISHED BY: DATE/TIME Brian Blisk 5-16-94 09:05 RECEIVED BY: DATE/TIME John Washt AF 5/17/94 9:15

to Fed Ex air bill # 1968964200 RECEIVED BY: DATE/TIME _____

LAB USE ONLY

SHIPPER NAME Fed-X AIR BILL # 1968964200 OPENED BY: DATE/TIME JW 5/17/94 9:15 TEMP (°C) Room CONDITION Good

REMARKS Custody Seal intact? Y N None Temp. Room

APPENDIX E

TEST DATA AND CALCULATIONS

EXTENDED TESTING DATA SHEET
AFCEE BIOVENTING

Base Cannon
Site CA1 - Sumu 70

Sampler(s) RDW/JEW
Date 5-25-94 17:00
Test Type ~~()~~ ~~()~~

INITIAL SOIL GAS CHEMISTRY

Monitoring Point	CO ₂ (%)	O ₂ (%)	TVH * (ppm)	Temperature (F)	Comments
MPA-5	2.5	18.0	19,000	—	60s purge 20s stabilized
MPA-25	5.9	13.8	8,000	—	60s purge 40s stabilized
MPA-50	5.7	16.1	10,000	—	90s purge 20s stabilized
MPA-70	1.1	19.5	5,400	—	90s purge 90s purge
MPA-110	0.1	20.8	340	—	150s purge 150s purge
MPB-5	11.1	0.0	4,400	—	30s purge 30s purge
- 25	9.6	0.5	14,400	—	45s purge 45s purge
- 50	11.3	7.9	7400	—	75s purge 75s purge
- 70	0.5	20.5	RDW 900	—	90s purge 90s purge
- 110	1.8	20.5	440	—	90s purge 90s purge

* - with dilution fitting (after multiplying by 2)
BLOWER PERFORMANCE

Vacuum 1 ("H ₂ O)	Vacuum 2 ("H ₂ O)	Pressure ("H ₂ O)	Temperature (F)	Flow Rate (cfm)	Comments
4.3		6.4	81°F		

SOIL SAMPLES

Monitoring Point	Depth (feet)	Sample Number	Date	Time	Comments

SOIL GAS SAMPLES

Monitoring Point	Depth (feet)	Sample Number	Date	Time	Canister Number

EXTENDED TESTING DATA SHEET
AFCEE BIOVENTING

Base Cannon AFB
Site CA1 - SWMU 70

Sampler(s) RDW/JEW
Date 5-25-94 17:00
Test Type (~~6-10-11~~) (~~1-1-1~~)

INITIAL SOIL GAS CHEMISTRY

Monitoring Point	CO ₂ (%)	O ₂ (%)	TVH * (ppm)	Temperature (F)	Comments
mPL-5	13.5	2.1	7,000	-	30 s purge 30 s purge
-75	4.2	3.3	2,000	-	45 s purge 45 s purge
-50	8.3	18.0	760	-	60 s purge 20 s stabilized
-70	0.7	20.7	320	-	90 s purge 90 s purge
-110	3.3	20.5	400	-	90 s purge 11 s stabilized
resample 110	3.2	20.4	360	-	with 90 s purge

with dilution fitting (after multiplying)

BLOWER PERFORMANCE

Vacuum 1 (" H ₂ O)	Vacuum 2 (" H ₂ O)	Pressure (" H ₂ O)	Temperature (F)	Flow Rate (cfm)	Comments

SOIL SAMPLES

Monitoring Point	Depth (feet)	Sample Number	Date	Time	Comments

SOIL GAS SAMPLES

Monitoring Point	Depth (feet)	Sample Number	Date	Time	Canister Number

Air Permeability Test - Data Analysis (cont.)

① Enter radial distances of monitoring points $r =$ (ft)

② Enter measured times and gauge vacuums

③ Enter (optional):

 a) flowrate (SCFM)

 b) screened interval thickness (ft)

	MPA-25		MPA-50		MPA-70	
	(min)	(in H2O)	(min)	(in H2O)	(min)	(in H2O)
1	.18	↑	.5	↑	2.4	↑
2	.36	□	1.15	□	3.7	□
3	.51	▨	1.70	▨	4.4	▨
4	.60	▨	2.0	▨	5.0	▨
5	.67	▨	2.3	▨	5.4	▨
6	.71	▨	2.5	▨	5.7	▨
7	.76	▨	2.7	▨	6.0	▨
8	.80	▨	2.85	▨	6.3	▨
9	.83	▨	3.0	▨	6.5	▨
10	.86	↓	3.1	↓	6.7	↓

k= darcy (A) k= darcy (A) k= darcy (A)

 k= darcy (B) k= darcy (B) k= darcy (B)



Air Permeability Test - Data Analysis (cont.)

On the previous Card (AP8), the data you input were fit to the approximate expression given on Card AP6. It was analyzed using both methods described on card AP7, if you input values for the extraction well flowrate (Q) and the stratum thickness (m). Below each column of data, the two calculated permeability values are denoted by:

darcy(A) - refers to calculation method 1 (see Card AP7)

darcy(B) - refers to calculation method 2 (see Card AP7)

During the regression analyses, the data expressed as pairs of points ($\ln(t), P'$) are fit to a line. The "correlation coefficient", r , is a measure of how well the data conform to the theoretical curve. As $r \rightarrow 1$, the data points all fall on the theoretical curve. At the right are given the correlation coefficient values for the three data sets. For more info on the meaning of r , consult any introductory Statistics book.

Correlation Coef.
(r)

data set #1

data set #2

data set #3



Return

AP9

Cannon AFB / CA1-SWU70

Air Permeability Test - Data Analysis (cont.)

① Enter radial distances of monitoring points → $r =$ (ft) ^{*MPA10*} $r =$ (ft) ^{*MPA5*} $r =$ (ft) ^{*MPA25*}

(min) (in H2O) (min) (in H2O) (min) (in H2O)

② Enter measured times and gauge vacuums

1	1.2	↑	1	.01	↑	1	.04	↑
2	2.2	□	2.5	.025	□	2.5	.135	□
3	2.8	▨	4	.04	▨	4	.21	▨
4	3.35	▩	5.5	.055	▩	5.5	.29	▩
5	3.75	▪	6.5	.06	▪	6.5	.34	▪
6	4.05	▫	8	.065	▫	8	.37	▫
7	4.25	▬	9	.07	▬	9	.405	▬
8	4.5	▭	10	.075	▭	10	.42	▭
9	4.65	▮	12	.08	▮	12	.465	▮
10	4.85	▯	14	.095	▯	14	.52	▯

③ Enter (optional):

a) flowrate (SCFM)

b) screened interval thickness (ft)

--> Calculate <-- $k =$ darcy (A) $k =$ darcy (A) $k =$ darcy (A)
 $k =$ darcy (B) $k =$ darcy (B) $k =$ darcy (B)

QC-SH-6-20-94

Air Permeability Test - Data Analysis (cont.)

<p>① Enter radial distances of monitoring points → r= <input style="width: 50px;" type="text" value="9.3"/> (ft)</p> <p>② Enter measured times and gauge vacuums →</p> <p>③ Enter (optional):</p> <p>a) flowrate <input style="width: 50px;" type="text" value="61"/> (SCFM)</p> <p>b) screened interval thickness <input style="width: 50px;" type="text" value="100"/> (ft)</p>	<p style="text-align: center;"><i>MPA110</i></p> <p>r= <input style="width: 50px;" type="text" value="19.1"/> (ft)</p> <table border="1" style="width: 100%; border-collapse: collapse; text-align: center;"> <thead> <tr> <th>(min)</th> <th>(in H2O)</th> </tr> </thead> <tbody> <tr><td>12</td><td>5.0</td></tr> <tr><td>14</td><td>5.2</td></tr> <tr><td>16</td><td>5.4</td></tr> <tr><td>18</td><td>5.55</td></tr> <tr><td>20</td><td>5.7</td></tr> <tr><td>23</td><td>5.8</td></tr> <tr><td>26</td><td>5.9</td></tr> <tr><td>29</td><td>6.0</td></tr> <tr><td>32</td><td>6.1</td></tr> <tr><td>36</td><td>6.2</td></tr> </tbody> </table> <p style="text-align: center;"><input type="button" value="clear"/></p>	(min)	(in H2O)	12	5.0	14	5.2	16	5.4	18	5.55	20	5.7	23	5.8	26	5.9	29	6.0	32	6.1	36	6.2	<p style="text-align: center;"><i>MPB5</i></p> <p>r= <input style="width: 50px;" type="text" value="19.1"/> (ft)</p> <table border="1" style="width: 100%; border-collapse: collapse; text-align: center;"> <thead> <tr> <th>(min)</th> <th>(in H2O)</th> </tr> </thead> <tbody> <tr><td>16</td><td>.097</td></tr> <tr><td>18</td><td>.105</td></tr> <tr><td>20</td><td>.11</td></tr> <tr><td>23</td><td>.11</td></tr> <tr><td>26</td><td>.12</td></tr> <tr><td>29</td><td>.125</td></tr> <tr><td>32</td><td>.135</td></tr> <tr><td>36</td><td>.135</td></tr> <tr><td>40</td><td>.135</td></tr> <tr><td>45</td><td>.153</td></tr> </tbody> </table> <p style="text-align: center;"><input type="button" value="clear"/></p>	(min)	(in H2O)	16	.097	18	.105	20	.11	23	.11	26	.12	29	.125	32	.135	36	.135	40	.135	45	.153
(min)	(in H2O)																																													
12	5.0																																													
14	5.2																																													
16	5.4																																													
18	5.55																																													
20	5.7																																													
23	5.8																																													
26	5.9																																													
29	6.0																																													
32	6.1																																													
36	6.2																																													
(min)	(in H2O)																																													
16	.097																																													
18	.105																																													
20	.11																																													
23	.11																																													
26	.12																																													
29	.125																																													
32	.135																																													
36	.135																																													
40	.135																																													
45	.153																																													
<p>→ <input type="button" value="Calculate"/> ←</p>	<p>k= <input style="width: 50px;" type="text" value="3.89086"/> darcy (A) k= <input style="width: 50px;" type="text" value="8.58839"/> darcy (B)</p>	<p style="text-align: center;"><i>MPB 25</i></p> <p>r= <input style="width: 50px;" type="text" value="19.1"/> (ft)</p> <table border="1" style="width: 100%; border-collapse: collapse; text-align: center;"> <thead> <tr> <th>(min)</th> <th>(in H2O)</th> </tr> </thead> <tbody> <tr><td>16</td><td>.6</td></tr> <tr><td>18</td><td>.6</td></tr> <tr><td>20</td><td>.6</td></tr> <tr><td>23</td><td>.65</td></tr> <tr><td>26</td><td>.65</td></tr> <tr><td>29</td><td>.67</td></tr> <tr><td>32</td><td>.69</td></tr> <tr><td>36</td><td>.70</td></tr> <tr><td>40</td><td>.70</td></tr> <tr><td>45</td><td>.72</td></tr> </tbody> </table> <p style="text-align: center;"><input type="button" value="clear"/></p> <p>k= <input style="width: 50px;" type="text" value="27.0217"/> darcy (A) k= <input style="width: 50px;" type="text" value="11.9359"/> darcy (B)</p>	(min)	(in H2O)	16	.6	18	.6	20	.6	23	.65	26	.65	29	.67	32	.69	36	.70	40	.70	45	.72																						
(min)	(in H2O)																																													
16	.6																																													
18	.6																																													
20	.6																																													
23	.65																																													
26	.65																																													
29	.67																																													
32	.69																																													
36	.70																																													
40	.70																																													
45	.72																																													



Return



Explanation & Statistics

AP8

Air Permeability Test - Data Analysis (cont.)

On the previous Card (AP8), the data you input were fit to the approximate expression given on Card AP6. It was analyzed using both methods described on card AP7, if you input values for the extraction well flowrate (Q) and the stratum thickness (m). Below each column of data, the two calculated permeability values are denoted by:

darcy(A) - refers to calculation method 1 (see Card AP7)

darcy(B) - refers to calculation method 2 (see Card AP7)

During the regression analyses, the data expressed as pairs of points ($\ln(t), P'$) are fit to a line. The "correlation coefficient", r , is a measure of how well the data conform to the theoretical curve. As $r \rightarrow 1$, the data points all fall on the theoretical curve. At the right are given the correlation coefficient values for the three data sets. For more info on the meaning of r , consult any introductory Statistics book.

	Correlation Coef. (r)
data set #1	0.994729
data set #2	0.984629
data set #3	0.988094



Return

AP9

Cannon AIB / CA1 - SWMU 70

Air Permeability Test - Data Analysis (cont.)

	<i>MPB50</i>		<i>MPB70</i>		<i>MPB110</i>	
① Enter radial distances of monitoring points → r=	19.1 (ft)		19.1 (ft)		19.1 (ft)	
	(min)	(in H2O)	(min)	(in H2O)	(min)	(in H2O)
② Enter measured times and gauge vacuums →	1	.2	1	1.15	1	.4
	2.5	.4	2.5	2.05	2.5	.95
③ Enter (optional):	4	.6	4	2.55	4	1.3
a) flowrate	5.5	.8	5.5	3.0	5.5	1.7
<input type="text" value="61"/> (SCFM)	6.5	.95	6.5	3.3	6.5	1.95
b) screened interval thickness	8	1.1	8	3.55	8	2.2
<input type="text" value="100"/> (ft)	9	1.2	9	3.8	9	2.35
<input type="text" value="clear"/>	10	1.25	10	3.9	10	2.5
	12	1.45	12	4.15	12	2.7
	14	1.6	14	4.4	14	2.95
<input type="text" value="clear"/>			<input type="text" value="clear"/>		<input type="text" value="clear"/>	
<input type="button" value="--> Calculate <--"/>	k= 8.30597	darcy (A)	k= 4.35121	darcy (A)	k= 4.99130	darcy (A)
	k= 10.6585	darcy (B)	k= 29.4089	darcy (B)	k= 13.6187	darcy (B)

QC-SF-6/20/94

Air Permeability Test - Data Analysis (cont.)

<p>① Enter radial distances of monitoring points → r= <input style="width: 60px;" type="text" value="19.1"/> (ft)</p> <p>② Enter measured times and gauge vacuums →</p> <p>③ Enter (optional):</p> <p>a) flowrate <input style="width: 60px;" type="text" value="61"/> (SCFM)</p> <p>b) screened interval thickness <input style="width: 60px;" type="text" value="100"/> (ft)</p>	<p style="text-align: center;"><i>MPB50</i></p> <p>r= <input style="width: 60px;" type="text" value="19.1"/> (ft)</p> <table border="1" style="width: 100%; border-collapse: collapse; text-align: center;"> <thead> <tr> <th>(min)</th> <th>(in H2O)</th> </tr> </thead> <tbody> <tr><td>16</td><td>1.75</td></tr> <tr><td>18</td><td>1.8</td></tr> <tr><td>20</td><td>1.9</td></tr> <tr><td>23</td><td>2.0</td></tr> <tr><td>26</td><td>2.05</td></tr> <tr><td>29</td><td>2.15</td></tr> <tr><td>32</td><td>2.2</td></tr> <tr><td>36</td><td>2.25</td></tr> <tr><td>40</td><td>2.3</td></tr> <tr><td>45</td><td>2.35</td></tr> </tbody> </table> <p style="text-align: center;">clear</p>	(min)	(in H2O)	16	1.75	18	1.8	20	1.9	23	2.0	26	2.05	29	2.15	32	2.2	36	2.25	40	2.3	45	2.35	<p style="text-align: center;"><i>MPB70</i></p> <p>r= <input style="width: 60px;" type="text" value="19.1"/> (ft)</p> <table border="1" style="width: 100%; border-collapse: collapse; text-align: center;"> <thead> <tr> <th>(min)</th> <th>(in H2O)</th> </tr> </thead> <tbody> <tr><td>16</td><td>4.6</td></tr> <tr><td>18</td><td>4.7</td></tr> <tr><td>20</td><td>4.85</td></tr> <tr><td>23</td><td>5.0</td></tr> <tr><td>26</td><td>5.1</td></tr> <tr><td>29</td><td>5.3</td></tr> <tr><td>32</td><td>5.4</td></tr> <tr><td>36</td><td>5.5</td></tr> <tr><td>40</td><td>5.6</td></tr> <tr><td>45</td><td>5.63</td></tr> </tbody> </table> <p style="text-align: center;">clear</p>	(min)	(in H2O)	16	4.6	18	4.7	20	4.85	23	5.0	26	5.1	29	5.3	32	5.4	36	5.5	40	5.6	45	5.63	<p style="text-align: center;"><i>MPB110</i></p> <p>r= <input style="width: 60px;" type="text" value="19.1"/> (ft)</p> <table border="1" style="width: 100%; border-collapse: collapse; text-align: center;"> <thead> <tr> <th>(min)</th> <th>(in H2O)</th> </tr> </thead> <tbody> <tr><td>16</td><td>3.1</td></tr> <tr><td>18</td><td>3.25</td></tr> <tr><td>20</td><td>3.35</td></tr> <tr><td>23</td><td>3.5</td></tr> <tr><td>26</td><td>3.65</td></tr> <tr><td>29</td><td>3.78</td></tr> <tr><td>32</td><td>3.85</td></tr> <tr><td>36</td><td>4.0</td></tr> <tr><td>40</td><td>4.1</td></tr> <tr><td>45</td><td>4.25</td></tr> </tbody> </table> <p style="text-align: center;">clear</p>	(min)	(in H2O)	16	3.1	18	3.25	20	3.35	23	3.5	26	3.65	29	3.78	32	3.85	36	4.0	40	4.1	45	4.25
(min)	(in H2O)																																																																				
16	1.75																																																																				
18	1.8																																																																				
20	1.9																																																																				
23	2.0																																																																				
26	2.05																																																																				
29	2.15																																																																				
32	2.2																																																																				
36	2.25																																																																				
40	2.3																																																																				
45	2.35																																																																				
(min)	(in H2O)																																																																				
16	4.6																																																																				
18	4.7																																																																				
20	4.85																																																																				
23	5.0																																																																				
26	5.1																																																																				
29	5.3																																																																				
32	5.4																																																																				
36	5.5																																																																				
40	5.6																																																																				
45	5.63																																																																				
(min)	(in H2O)																																																																				
16	3.1																																																																				
18	3.25																																																																				
20	3.35																																																																				
23	3.5																																																																				
26	3.65																																																																				
29	3.78																																																																				
32	3.85																																																																				
36	4.0																																																																				
40	4.1																																																																				
45	4.25																																																																				
<p>-->Calculate<--</p>	<p>k= <input style="width: 60px;" type="text" value="8.30597"/> darcy (A)</p> <p>k= <input style="width: 60px;" type="text" value="10.6585"/> darcy (B)</p>	<p>k= <input style="width: 60px;" type="text" value="4.35121"/> darcy (A)</p> <p>k= <input style="width: 60px;" type="text" value="29.4089"/> darcy (B)</p>	<p>k= <input style="width: 60px;" type="text" value="4.99130"/> darcy (A)</p> <p>k= <input style="width: 60px;" type="text" value="13.6187"/> darcy (B)</p>																																																																		



Return



Explanation & Statistics

AP8

Air Permeability Test - Data Analysis (cont.)

On the previous Card (AP8), the data you input were fit to the approximate expression given on Card AP6. It was analyzed using both methods described on card AP7, if you input values for the extraction well flowrate (Q) and the stratum thickness (m). Below each column of data, the two calculated permeability values are denoted by:

darcy(A) - refers to calculation method 1 (see Card AP7)

darcy(B) - refers to calculation method 2 (see Card AP7)

During the regression analyses, the data expressed as pairs of points ($\ln(t), P'$) are fit to a line. The "correlation coefficient", r , is a measure of how well the data conform to the theoretical curve. As $r \rightarrow 1$, the data points all fall on the theoretical curve. At the right are given the correlation coefficient values for the three data sets. For more info on the meaning of r , consult any introductory Statistics book.

Correlation Coef.

(r)

data set #1

data set #2

data set #3



Return

AP9

Cammie AFB / CA1-SWNU70

Air Permeability Test - Data Analysis (cont.)

	<i>MPC 25</i>	<i>MPC 50</i>	<i>MPC 70</i>
① Enter radial distances of monitoring points → r=	34.0 (ft)	34.0 (ft)	34.0 (ft)
	(min) (in H2O)	(min) (in H2O)	(min) (in H2O)
② Enter measured times and gauge vacuums →	1 .02	1 .04	1 .45
	2.5 .03	2.5 .09	2.5 .85
	4 .055	4 .15	4 1.1
	5.5 .105	5.5 .28	5.5 1.4
③ Enter (optional):	6.5 .12	6.5 .34	6.5 1.55
a) flowrate	8 .16	8 .45	8 1.75
<input type="text" value="61"/> (SCFM)	9 .175	9 .51	9 1.9
b) screened interval thickness	10 .20	10 .58	10 2.05
<input type="text" value="100"/> (ft)	12 .24	12 .70	12 2.22
	14 .34	14 .83	14 2.45
	<input type="button" value="clear"/>	<input type="button" value="clear"/>	<input type="button" value="clear"/>
<input type="button" value="-->Calculate<--"/>	k= <input type="text" value="27.3504"/> darcy (A)	k= <input type="text" value="9.56501"/> darcy (A)	k= <input type="text" value="5.93412"/> darcy (A)
	k= <input type="text" value="17.6795"/> darcy (B)	k= <input type="text" value="17.1385"/> darcy (B)	k= <input type="text" value="42.8543"/> darcy (B)



Return



Explanation & Statistics

AP8

AP-514 - 6/20/94

Air Permeability Test - Data Analysis (cont.)

	<i>MPC 25</i> Enter radial distances of monitoring points → r= <input type="text" value="34.0"/> (ft)	<i>MPC 50</i> r= <input type="text" value="34.0"/> (ft)	<i>MPC 70</i> r= <input type="text" value="34.0"/> (ft)																																																																		
① Enter radial distances of monitoring points ② Enter measured times and gauge vacuums ③ Enter (optional): a) flowrate <input type="text" value="61"/> (SCFM) b) screened interval thickness <input type="text" value="100"/> (ft)	<table border="1" style="margin: auto;"> <thead> <tr> <th>(min)</th> <th>(in H2O)</th> </tr> </thead> <tbody> <tr><td>16</td><td>.38</td></tr> <tr><td>18</td><td>.40</td></tr> <tr><td>20</td><td>.43</td></tr> <tr><td>23</td><td>.465</td></tr> <tr><td>26</td><td>.51</td></tr> <tr><td>29</td><td>.54</td></tr> <tr><td>32</td><td>.57</td></tr> <tr><td>36</td><td>.595</td></tr> <tr><td>40</td><td>.61</td></tr> <tr><td>45</td><td>.65</td></tr> </tbody> </table> <p style="text-align: center;"><input type="button" value="clear"/></p>	(min)	(in H2O)	16	.38	18	.40	20	.43	23	.465	26	.51	29	.54	32	.57	36	.595	40	.61	45	.65	<table border="1" style="margin: auto;"> <thead> <tr> <th>(min)</th> <th>(in H2O)</th> </tr> </thead> <tbody> <tr><td>16</td><td>.91</td></tr> <tr><td>18</td><td>.99</td></tr> <tr><td>20</td><td>1.3</td></tr> <tr><td>23</td><td>1.4</td></tr> <tr><td>26</td><td>1.47</td></tr> <tr><td>29</td><td>1.55</td></tr> <tr><td>32</td><td>1.65</td></tr> <tr><td>36</td><td>1.7</td></tr> <tr><td>40</td><td>1.73</td></tr> <tr><td>45</td><td>1.83</td></tr> </tbody> </table> <p style="text-align: center;"><input type="button" value="clear"/></p>	(min)	(in H2O)	16	.91	18	.99	20	1.3	23	1.4	26	1.47	29	1.55	32	1.65	36	1.7	40	1.73	45	1.83	<table border="1" style="margin: auto;"> <thead> <tr> <th>(min)</th> <th>(in H2O)</th> </tr> </thead> <tbody> <tr><td>16</td><td>2.55</td></tr> <tr><td>18</td><td>2.70</td></tr> <tr><td>20</td><td>2.80</td></tr> <tr><td>23</td><td>2.95</td></tr> <tr><td>26</td><td>3.1</td></tr> <tr><td>29</td><td>3.2</td></tr> <tr><td>32</td><td>3.3</td></tr> <tr><td>36</td><td>3.4</td></tr> <tr><td>40</td><td>3.47</td></tr> <tr><td>45</td><td>3.64</td></tr> </tbody> </table> <p style="text-align: center;"><input type="button" value="clear"/></p>	(min)	(in H2O)	16	2.55	18	2.70	20	2.80	23	2.95	26	3.1	29	3.2	32	3.3	36	3.4	40	3.47	45	3.64
(min)	(in H2O)																																																																				
16	.38																																																																				
18	.40																																																																				
20	.43																																																																				
23	.465																																																																				
26	.51																																																																				
29	.54																																																																				
32	.57																																																																				
36	.595																																																																				
40	.61																																																																				
45	.65																																																																				
(min)	(in H2O)																																																																				
16	.91																																																																				
18	.99																																																																				
20	1.3																																																																				
23	1.4																																																																				
26	1.47																																																																				
29	1.55																																																																				
32	1.65																																																																				
36	1.7																																																																				
40	1.73																																																																				
45	1.83																																																																				
(min)	(in H2O)																																																																				
16	2.55																																																																				
18	2.70																																																																				
20	2.80																																																																				
23	2.95																																																																				
26	3.1																																																																				
29	3.2																																																																				
32	3.3																																																																				
36	3.4																																																																				
40	3.47																																																																				
45	3.64																																																																				
<input type="button" value="-->Calculate<--"/>	k= <input type="text" value="27.3504"/> darcy (A) k= <input type="text" value="17.6795"/> darcy (B)	k= <input type="text" value="9.56501"/> darcy (A) k= <input type="text" value="17.1385"/> darcy (B)	k= <input type="text" value="5.93412"/> darcy (A) k= <input type="text" value="42.8543"/> darcy (B)																																																																		



Return



Explanation & Statistics

AP8

Air Permeability Test - Data Analysis (cont.)

On the previous Card (AP8), the data you input were fit to the approximate expression given on Card AP6. It was analyzed using both methods described on card AP7, if you input values for the extraction well flowrate (Q) and the stratum thickness (m). Below each column of data, the two calculated permeability values are denoted by:

darcy(A) - refers to calculation method 1 (see Card AP7)

darcy(B) - refers to calculation method 2 (see Card AP7)

During the regression analyses, the data expressed as pairs of points ($\ln(t), P'$) are fit to a line. The "correlation coefficient", r , is a measure of how well the data conform to the theoretical curve. As $r \rightarrow 1$, the data points all fall on the theoretical curve. At the right are given the correlation coefficient values for the three data sets. For more info on the meaning of r , consult any introductory Statistics book.

Correlation Coef.

(r)

data set #1

data set #2

data set #3



Return

AP9

Cannon AIB / CA1-SWMU 70

Air Permeability Test - Data Analysis (cont.)

① Enter radial distances of monitoring points → $r =$ (ft) $r =$ (ft) $r =$ (ft)

(min) (in H2O) (min) (in H2O) (min) (in H2O)

② Enter measured times and gauge vacuums

1	.15	<input type="text"/>	<input type="text"/>
2.5	.35	<input type="text"/>	<input type="text"/>
4	.5	<input type="text"/>	<input type="text"/>
5.5	.75	<input type="text"/>	<input type="text"/>
6.5	.85	<input type="text"/>	<input type="text"/>
8	1.1	<input type="text"/>	<input type="text"/>
9	1.15	<input type="text"/>	<input type="text"/>
10	1.25	<input type="text"/>	<input type="text"/>
12	1.45	<input type="text"/>	<input type="text"/>
14	1.7	<input type="text"/>	<input type="text"/>

③ Enter (optional):

a) flowrate (SCFM)

b) screened interval thickness (ft)

--> **Calculate** <--

k= darcy (A) k= darcy (A) k= darcy (A)

k= darcy (B) k= darcy (B) k= darcy (B)



AP8

AP-SP-6/20/94

Air Permeability Test - Data Analysis (cont.)

1 Enter radial distances of monitoring points → r= (ft) r= (ft) r= (ft)

2 Enter measured times and gauge vacuums

	(min)	(in H2O)	
	16	1.8	↑
	18	1.95	□
	20	2.0	▨
	23	2.15	▨
	26	2.25	▨
	29	2.4	▨
	32	2.5	▨
	36	2.6	▨
	40	2.7	□
	45	2.85	↓

3 Enter (optional):

a) flowrate (SCFM)

b) screened interval thickness (ft)

k= darcy (A)
k= darcy (A)
k= darcy (A)

k= darcy (B)
k= darcy (B)
k= darcy (B)



AP8

Air Permeability Test - Data Analysis (cont.)

On the previous Card (AP8), the data you input were fit to the approximate expression given on Card AP6. It was analyzed using both methods described on card AP7, if you input values for the extraction well flowrate (Q) and the stratum thickness (m). Below each column of data, the two calculated permeability values are denoted by:

darcy(A) - refers to calculation method 1 (see Card AP7)

darcy(B) - refers to calculation method 2 (see Card AP7)

During the regression analyses, the data expressed as pairs of points $(\ln(t), P')$ are fit to a line. The "correlation coefficient", r , is a measure of how well the data conform to the theoretical curve. As $r \rightarrow 1$, the data points all fall on the theoretical curve. At the right are given the correlation coefficient values for the three data sets. For more info on the meaning of r , consult any introductory Statistics book.

Correlation Coef.
(r)

data set #1

data set #2

data set #3



Return

AP9

**25ft MPS Interval
Steady-State Equation – Air Injection**

Enter data

$$k = \frac{Q \mu \ln(Rw/Ri)}{H \pi Patm [1 - (Pw/Patm)^2]}$$

Calculated data

Where:

Q = Volumetric flow rate of vent well

scfm x (30.48 cm/ft)³ x (1 min/60 s) = cm³/s

μ = Viscosity of Air @ 18° C = g/cm s

Patm = Ambient pressure @ _____ feet of elevation (use Excel table to get this number)

inches H2O x (3.61E-2 psia/in. H2O) = psia

psia x (6.89476E4 g/cm s²)/psia = g/cm s²

Rw = Radius of Vent Well

inches x 2.54 cm/in = cm

H = Depth of Screen (length of screened interval)

feet x 30.48 cm/ft = cm

Ri = Maximum Radius of Venting Influence

feet x 30.48 cm/ft = cm

Pw = Absolute Pressure at Vent Well

inches H2O x (3.61E-2 psia/in. H2O) = psia

psia + psia = psia

psia x (6.89476E4 g/cm s²)/psia = g/cm s²

k = cm²

cm² x (1 m/100 cm)² = m²

m² x 1 darcy/(9.870E-13 m²) = darcys

50ft MPS Interval
Steady-State Equation – Air Injection

Enter data

$$k = \frac{Q \mu \ln (R_w / R_i)}{H \pi P_{atm} [1 - (P_w / P_{atm})^2]}$$

Calculated data

Where:

Q = Volumetric flow rate of vent well

scfm x (30.48 cm/ft)³ x (1 min/60 s) = cm³/s

μ = Viscosity of Air @ 18° C = g/cm s

P_{atm} = Ambient pressure @ _____ feet of elevation (use Excel table to get this number)

inches H₂O x (3.61E-2 psia/in. H₂O) = psia

psia x (6.89476E4 g/cm s²)/psia = g/cm s²

R_w = Radius of Vent Well

inches x 2.54 cm/in = cm

H = Depth of Screen (length of screened interval)

feet x 30.48 cm/ft = cm

R_i = Maximum Radius of Venting Influence

feet x 30.48 cm/ft = cm

P_w = Absolute Pressure at Vent Well

inches H₂O x (3.61E-2 psia/in. H₂O) = psia

psia + psia = psia

psia x (6.89476E4 g/cm s²)/psia = g/cm s²

k = cm²

cm² x (1 m/100 cm)² = m²

m² x 1 darcy/(9.870E-13 m²) = darcys

70ft MPS Interval
Steady-State Equation – Air Injection

Enter data

Calculated data

$$k = \frac{Q \mu \ln (R_w / R_i)}{H \pi P_{atm} [1 - (P_w / P_{atm})^2]}$$

Where:

Q = Volumetric flow rate of vent well

scfm x (30.48 cm/ft)³ x (1 min/60 s) = cm³/s

μ = Viscosity of Air @ 18° C = g/cm s

P_{atm} = Ambient pressure @ _____ feet of elevation (use Excel table to get this number)

inches H₂O x (3.61E-2 psia/in. H₂O) = psia

psia x (6.89476E4 g/cm s²)/psia = g/cm s²

R_w = Radius of Vent Well

inches x 2.54 cm/in = cm

H = Depth of Screen (length of screened interval)

feet x 30.48 cm/ft = cm

R_i = Maximum Radius of Venting Influence

feet x 30.48 cm/ft = cm

P_w = Absolute Pressure at Vent Well

inches H₂O x (3.61E-2 psia/in. H₂O) = psia

psia + psia = psia

psia x (6.89476E4 g/cm s²)/psia = g/cm s²

k = cm²

cm² x (1 m/100 cm)² = m²

m² x 1 darcy/(9.870E-13 m²) = darcys

110ft MPS Interval
Steady-State Equation – Air Injection

Enter data

$$k = \frac{Q \mu \ln(Rw/Ri)}{H \pi Patm [1 - (Pw/Patm)^2]}$$

Calculated data

Where:

Q = Volumetric flow rate of vent well

scfm x (30.48 cm/ft)³ x (1 min/60 s) = cm³/s

μ = Viscosity of Air @ 18° C = g/cm s

Patm = Ambient pressure @ _____ feet of elevation (use Excel table to get this number)

inches H2O x (3.61E-2 psia/in. H2O) = psia

psia x (6.89476E4 g/cm s²)/psia = g/cm s²

Rw = Radius of Vent Well

inches x 2.54 cm/in = cm

H = Depth of Screen (length of screened interval)

feet x 30.48 cm/ft = cm

Ri = Maximum Radius of Venting Influence

feet x 30.48 cm/ft = cm

Pw = Absolute Pressure at Vent Well

inches H2O x (3.61E-2 psia/in. H2O) = psia

psia + psia = psia

psia x (6.89476E4 g/cm s²)/psia = g/cm s²

k = cm²

cm² x (1 m/100 cm)² = m²

m² x 1 darcy/(9.870E-13 m²) = darcys

Respiration Test
CA1-SWMU 70
Cannon AFB, NM

Monitoring Point	Date	Days Elapsed (frac. days)	Time	Hrs elapsed (fractional days)	Days Elapsed	Elapsed Time (min. x 1000)	O2%	CO2%	Total Hydrocarbon	Helium	Comments	Trend of O2 Time	New x-values	k
CA1-MPA-5	05/12/94	0.00	12:19	0.01	0.01	0.01	20.2	0.05	550	0.00		17.363574	0	0.012922
CA1-MPA-5	05/12/94	0.00	14:10	0.08	0.08	0.12	15.7	0.60	2,600	0.00		-1.3731946	1.45	
CA1-MPA-5	05/12/94	0.00	16:19	0.17	0.17	0.25	13.0	1.50	4,600					
CA1-MPA-5	05/12/94	0.00	20:11	0.33	0.33	0.48	9.4	2.60	6,200					
CA1-MPA-5	05/13/94	1.00	00:02	-0.51	0.49	0.71	6.8	3.80	7,500					
CA1-MPA-5	05/13/94	1.00	06:49	-0.22	0.78	1.12	2.8	5.30	9,600		Temp=19.1C 5U sec purge TVH w/dsl fitting			
CA1-MPA-5	05/13/94	1.00	12:16	0.00	1.00	1.45	0.2	6.70	10,700		Used 2X diluter			
CA1-MPA-5	05/13/94	1.00	20:29	0.35	1.35	1.94	0.0	8.70	12,000		TVH w/dsl fitting			
CA1-MPA-5	05/14/94	2.00	07:10	-0.21	1.79	2.58	0.0	9.30	12,800		2X dilution fitting used			
CA1-MPA-5	05/14/94	2.00	17:45	0.23	2.23	3.22	0.0	10.20	14,100		2X dsl fitting used			
CA1-MPA-5	05/15/94	3.00	07:29	-0.20	2.80	4.04	0.0	10.80	15,000		Temp=18.7C 2X dil fitting			
CA1-MPA-25	05/12/94	0.00	12:29	0.01	0.01	0.02	20.2	0.05	220	1.10	Purged 2 min	19.726255	0	0.014182
CA1-MPA-25	05/12/94	0.00	14:15	0.09	0.09	0.13	18.4	0.09	900	2.90		-0.8381918	1.45	
CA1-MPA-25	05/12/94	0.00	16:23	0.18	0.18	0.25	16.0	0.08	1,000	1.80				
CA1-MPA-25	05/12/94	0.00	20:15	0.34	0.34	0.49	12.5	0.10	1,600					
CA1-MPA-25	05/13/94	1.00	00:04	-0.50	0.50	0.71	8.4	0.20	1,900					
CA1-MPA-25	05/13/94	1.00	06:51	-0.22	0.78	1.12	3.0	0.20	2,000		TVH w/ 90s purge dil fitting			
CA1-MPA-25	05/13/94	1.00	12:19	0.01	1.01	1.45	0.5	0.30	2,100		w/ 2X hydrocarbon diluter. 90s purge			
CA1-MPA-25	05/13/94	1.00	20:30	0.35	1.35	1.94	0.0	0.40	2,300		TVH w/ dil fitting (60s)			
CA1-MPA-25	05/14/94	2.00	07:12	-0.21	1.79	2.58	0.0	0.50	2,300		TVH w/ 2X dilution fitting			
CA1-MPA-25	05/14/94	2.00	17:47	0.23	2.23	3.22	0.0	0.50	2,600		w/ 2X dil fitting			
CA1-MPA-25	05/15/94	3.00	07:34	-0.19	2.81	4.04	0.0	0.60	3,000		w/ 2X dil fitting			
CA1-MPA-50	05/12/94	0.00	12:34	0.02	0.02	0.02	20.7	0.05	49	0.00	90 sec purge	20.043583	0	0.007827
CA1-MPA-50	05/12/94	0.00	14:24	0.09	0.09	0.13	19.5	0.08	215		He battery dead	-0.2283229	2.59	
CA1-MPA-50	05/12/94	0.00	16:29	0.18	0.18	0.26	18.1	0.09	400					
CA1-MPA-50	05/12/94	0.00	20:19	0.34	0.34	0.49	16.3	0.10	740					
CA1-MPA-50	05/13/94	1.00	00:08	-0.50	0.50	0.72	14.2	0.20	985					
CA1-MPA-50	05/13/94	1.00	06:57	-0.22	0.78	1.13	10.3	0.30	1,200					
CA1-MPA-50	05/13/94	1.00	12:24	0.01	1.01	1.45	7.3	0.40	1,500					
CA1-MPA-50	05/13/94	1.00	20:35	0.35	1.35	1.95	4.1	0.70	2,000					
CA1-MPA-50	05/14/94	2.00	07:18	-0.20	1.80	2.59	1.5	0.80	2,000		TVH w/ 2X dilution filter			
CA1-MPA-50	05/14/94	2.00	17:50	0.24	2.24	3.22	0.0	0.80	2,000		TVH w/ 2X dilution filter			
CA1-MPA-50	05/15/94	3.00	07:36	-0.19	2.81	4.05	0.0	0.90	2,400		w/ 2X dil. fitting			

Monitoring Point	Date	Days Elapsed (frac. days)	Hrs elapsed (fractional days)	Days Elapsed (min. x 1000)	O2%	CO2%	Total Hydro-carbon	Helium	Comments	Trend of O2 Time	New x-values	k
CA1-MPA-70	05/12/94	0.00	12:40	0.02	0.03	20.2	0.05	15	1.40	19.687141	0	0.003889
CA1-MPA-70	05/12/94	0.00	14:28	0.10	0.14	19.1	0.08	88		7.1657325	3.22	
CA1-MPA-70	05/12/94	0.00	16:34	0.18	0.26	18.6	0.10	120				
CA1-MPA-70	05/12/94	0.00	20:21	0.34	0.49	17.6	0.20	220				
CA1-MPA-70	05/13/94	1.00	00:11	-0.50	0.72	16.9	0.30	390				
CA1-MPA-70	05/13/94	1.00	07:01	-0.21	0.79	1.13	14.7	0.50	400			
CA1-MPA-70	05/13/94	1.00	12:30	0.01	1.01	1.46	13.8	0.80	490			
CA1-MPA-70	05/13/94	1.00	20:40	0.35	1.35	1.95	12.2	1.10	565			
CA1-MPA-70	05/14/94	2.00	07:23	-0.20	1.80	2.59	10.0	1.50	650			
CA1-MPA-70	05/14/94	2.00	17:54	0.24	2.24	3.22	7.1	1.90	760	w/o 2X filter (640 w/2X diluter)		
CA1-MPA-70	05/15/94	3.00	07:38	-0.19	2.81	4.05	5.6	2.50	925	w/o 2X filter (800 w/2X diluter)		
CA1-MPB-50	05/12/94	0.00	12:50	0.03	0.04	20.4	0.05	62	2.00	75s purge	21.078142	0
CA1-MPB-50	05/12/94	0.00	14:34	0.10	0.14	20.0	0.05	245	1.80		6.405222	2.6
CA1-MPB-50	05/12/94	0.00	16:42	0.19	0.27	19.6	0.08	390		Batteries dead on its meter		
CA1-MPB-50	05/12/94	0.00	20:24	0.34	0.34	18.7	0.09	610				
CA1-MPB-50	05/13/94	1.00	00:15	-0.50	0.50	0.73	17.8	0.09	770			
CA1-MPB-50	05/13/94	1.00	07:05	-0.21	0.79	1.14	14.7	0.10	1,000			
CA1-MPB-50	05/13/94	1.00	12:34	0.02	1.02	1.46	12.7	0.20	1,100			
CA1-MPB-50	05/13/94	1.00	20:43	0.36	1.36	1.95	9.1	0.20	1,400			
CA1-MPB-50	05/14/94	2.00	07:28	-0.20	1.80	2.60	6.9	0.20	1,500			
CA1-MPB-50	05/14/94	2.00	17:56	0.24	2.24	3.23	5.3	0.20	1,700			
CA1-MPB-50	05/15/94	3.00	07:49	-0.18	2.82	4.06	3.8	0.20	1,850	w/ 2X dil fitting		

Biodegradation Rate Calculations

enter data

calculated data

Formula: $K_b = K_o \times 1/100\% \times A \times D_o \times C$ Where:

K_b = fuel biodegradation rate

K_o = O_2 utilization rate (%/min.)

A = volume of air/kg soil

D_o = O_2 density 1340 mg/L

C = Carbon/ O_2 ratio for hexane mineralization = 1/3.5

Test Results:

MPA-5

K_o = max. observed rate

0.013

%/min.

w = moisture content

18.7

%

Assume:

Soil properties for Silty sand

Specify from

Table 1.4 (Ref. Foundation Engineering, Peck, Hanson, and Thornburn, John Wiley Press, 1974)

Porosity:

$n = 0.35$

Unit weight (dry):

$\gamma_d = 1.72$

Void ratio:

$e = n/1-n = 0.54$

Specific gravity:

G = 2.65

Calculate A = Air filled volume (V_a)/unit wt.

Solving for 1 liter of soil

a) $V_v = n \times 1 \text{ L}$

$V_v = 0.35$ liters V_v = void volume

b) $S_r = Gw/e$

$S_r = 0.92$ S_r = degree of saturation

c) $V_w = S_r \times V_v$

$V_w = 0.32$ liters V_w = volume of water

d) $V_a = V_v - V_{ww}$

$V_a = 0.03$ liters V_w = volume of water

e) Bulk density = $\gamma_d + (V_w \times \gamma_w) = 2$ kg/l soil

f) $A = V_a/\text{Bulk density} = 0.015$ l air/kg soil

$K_b = K_o \times 1/100\% \times A \times D_o \times C \times 525,600 \text{ min/yr} = 392$ mg TPH/year

Biodegradation Rate Calculations

enter data

calculated data

Formula: $K_b = K_o \times 1/100\% \times A \times D_o \times C$ Where: K_b = fuel biodegradation rate K_o = O_2 utilization rate (%/min.)

A = volume of air/kg soil

 D_o = O_2 density 1340 mg/LC = Carbon/ O_2 ratio for hexane mineralization = 1/3.5

Test Results:

MPA-25

 K_o = max. observed rate

0.014

%/min.

w = moisture content

18.4

%

Assume:

Soil properties for Silty sand

Specify from

Table 1.4 (Ref. Foundation Engineering, Peck, Hanson, and Thornburn, John Wiley Press, 1974)

Porosity:

 $n =$ 0.35

Unit weight (dry):

 $\%d =$ 1.72

Void ratio:

 $e = n/1 - n =$ 0.54

Specific gravity:

G = 2.65

Calculate A = Air filled volume (V_a)/unit wt.

Solving for 1 liter of soil

a) $V_v = n \times 1 \text{ L}$

$V_v =$ 0.35 liters V_v = void volume

b) $S_r = Gw/e$

$S_r =$ 0.9 S_r = degree of saturation

c) $V_w = S_r \times V_v$

$V_w =$ 0.32 liters V_w = volume of water

d) $V_a = V_v - V_{vw}$

$V_a =$ 0.03 liters V_w = volume of water

e) Bulk density = $\%d + (V_w \times \%w) =$ 2 kg/l soil

f) $A = V_a/\text{Bulk density} =$ 0.015 l air/kg soil

$K_b = K_o \times 1/100\% \times A \times D_o \times C \times 525,600 \text{ min/yr} =$ 423 mg TPH/year

Biodegradation Rate Calculations

enter data

calculated data

Formula: $K_b = K_o \times 1/100\% \times A \times D_o \times C$ Where: K_b = fuel biodegradation rate K_o = O_2 utilization rate (%/min.)

A = volume of air/kg soil

 D_o = O_2 density 1340 mg/LC = Carbon/ O_2 ratio for hexane mineralization = 1/3.5

Test Results:

MPA-50

 K_o = max. observed rate

0.0078

%/min.

w = moisture content

13.8

%

Assume:

Soil properties for Silty sand

Specify from

Table 1.4 (Ref. Foundation Engineering, Peck, Hanson, and Thornburn, John Wiley Press, 1974)

Porosity:

 $n = 0.35$

Unit weight (dry):

 $\gamma_d = 1.72$

Void ratio:

 $e = n/1-n = 0.54$

Specific gravity:

G = 2.65

Calculate A = Air filled volume (V_a)/unit wt.

Solving for 1 liter of soil

a) $V_v = n \times 1 \text{ L}$

$V_v = 0.35$ liters V_v = void volume

b) $S_r = Gw/e$

$S_r = 0.68$ S_r = degree of saturation

c) $V_w = S_r \times V_v$

$V_w = 0.24$ liters V_w = volume of water

d) $V_a = V_v - V_w$

$V_a = 0.11$ liters V_w = volume of water

e) Bulk density = $\gamma_d + (V_w \times \gamma_w) = 2$ kg/l soil

f) $A = V_a/\text{Bulk density} = 0.055$ l air/kg soil

$K_b = K_o \times 1/100\% \times A \times D_o \times C \times 525,600 \text{ min/yr} = 863$ mg TPH/year

Biodegradation Rate Calculations

enter data

calculated data

Formula: $K_b = K_o \times 1/100\% \times A \times D_o \times C$ Where:

K_b = fuel biodegradation rate

K_o = O_2 utilization rate (%/min.)

A = volume of air/kg soil

D_o = O_2 density 1340 mg/L

C = Carbon/ O_2 ratio for hexane mineralization = 1/3.5

Test Results:

MPA-70

K_o = max. observed rate

0.0039

%/min.

w = moisture content

11.8

%

Assume:

Soil properties for Mixed grained sand Specify from Table 1.4 (Ref. Foundation Engineering, Peck, Hanson, and Thornburn, John Wiley Press, 1974)

Porosity:

$n = 0.35$

Unit weight (dry):

$\gamma_d = 1.72$

Void ratio:

$e = n/1-n = 0.54$

Specific gravity:

G = 2.65

Calculate A = Air filled volume (V_a)/unit wt.

Solving for 1 liter of soil

a) $V_v = n \times 1 \text{ L}$

$V_v = 0.35$ liters V_v = void volume

b) $S_r = Gw/e$

$S_r = 0.58$ S_r = degree of saturation

c) $V_w = S_r \times V_v$

$V_w = 0.2$ liters V_w = volume of water

d) $V_a = V_v - V_w$

$V_a = 0.15$ liters V_w = volume of water

e) Bulk density = $\gamma_d + (V_w \times \gamma_w) = 1.9$ kg/l soil

f) $A = V_a/\text{Bulk density} = 0.079$ l air/kg soil

$K_b = K_o \times 1/100\% \times A \times D_o \times C \times 525,600 \text{ min/yr} = 620$ mg TPH/year

Biodegradation Rate Calculations

enter data

calculated data

Formula: $K_b = K_o \times 1/100\% \times A \times D_o \times C$ Where:

K_b = fuel biodegradation rate

K_o = O₂ utilization rate (%/min.)

A = volume of air/kg soil

D_o = O₂ density 1340 mg/L

C = Carbon/O₂ ratio for hexane mineralization = 1/3.5

Test Results:

MPB-50

K_o = max. observed rate

0.0056

%/min.

w = moisture content

9.1

%

Assume:

Soil properties for Silty sand

Specify from

Table 1.4 (Ref. Foundation Engineering, Peck, Hanson, and Thornburn, John Wiley Press, 1974)

Porosity:

$n = 0.35$

Unit weight (dry):

$\rho_d = 1.72$

Void ratio:

$e = n/1-n = 0.54$

Specific gravity:

G = 2.65

Calculate A = Air filled volume (V_a)/unit wt.

Solving for 1 liter of soil

a) $V_v = n \times 1 \text{ L}$

$V_v = 0.35$ liters V_v = void volume

b) $S_r = Gw/e$

$S_r = 0.45$ S_r = degree of saturation

c) $V_w = S_r \times V_v$

$V_w = 0.16$ liters V_w = volume of water

d) $V_a = V_v - V_w$

$V_a = 0.19$ liters V_w = volume of water

e) Bulk density = $\rho_d + (V_w \times \rho_w) = 1.9$ kg/l soil

f) $A = V_a/\text{Bulk density} = 0.1$ l air/kg soil

$K_b = K_o \times 1/100\% \times A \times D_o \times C \times 525,600 \text{ min/yr} = 1127$ mg TPH/year