

LOAN DOCUMENT

PHOTOGRAPH THIS SHEET

DTIC ACCESSION NUMBER

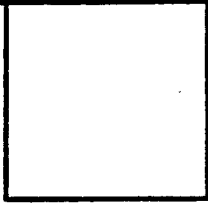

LEVEL

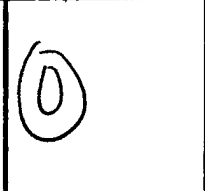

INVENTORY

Bioventing Test Work Plan for ...
DOCUMENT IDENTIFICATION
Oct 93

DISTRIBUTION STATEMENT A
Approved for Public Release
Distribution Unlimited

DISTRIBUTION STATEMENT

ACCESSION BOX	
NTIS	GRAM
DTIC	TRAC
UNANNOUNCED	
JUSTIFICATION	
BY	
DISTRIBUTION/	
AVAILABILITY CODES	
DISTRIBUTION	AVAILABILITY AND/OR SPECIAL
A-1	

DISTRIBUTION STAMP

--

DATE ACCESSIONED

--

DATE RETURNED

--

REGISTERED OR CERTIFIED NUMBER

DTIC QUANTITY REQUESTED 4
20001208 008

DATE RECEIVED IN DTIC

PHOTOGRAPH THIS SHEET AND RETURN TO DTIC-FDAC

H
A
N
D
L
E

W
I
T
H

C
A
R
E

**BIOVENTING TEST WORK PLAN FOR
AIR FORCE PLANT 6 (AFP 6)
IRP SITE #10 (JP-5 LEAK AREA)**

Prepared For

**Air Force Center for Environmental Excellence
Brooks AFB, Texas**

and

**Air Force Plant 6 (AFP6)
Lockheed-Georgia Company
Marietta, Georgia**

Prepared By

ENGINEERING-SCIENCE

Atlanta, Georgia

October 1993

ENGINEERING-SCIENCE
ES

AF 61-03-0176

DEFENSE TECHNICAL INFORMATION CENTER REQUEST FOR SCIENTIFIC AND TECHNICAL REPORTS

Title AFCEE Collection

1. Report Availability (Please check one box)

- This report is available. Complete sections 2a - 2f.
- This report is not available. Complete section 3.

2a. Number of Copies Forwarded

1 each

2b. Forwarding Date

July/2000

2c. Distribution Statement (Please check ONE box)

DoD Directive 5230.24, "Distribution Statements on Technical Documents," 18 Mar 87, contains seven distribution statements, as described briefly below. Technical documents MUST be assigned a distribution statement.

- DISTRIBUTION STATEMENT A: Approved for public release. Distribution is unlimited.
- DISTRIBUTION STATEMENT B: Distribution authorized to U.S. Government Agencies only.
- DISTRIBUTION STATEMENT C: Distribution authorized to U.S. Government Agencies and their contractors.
- DISTRIBUTION STATEMENT D: Distribution authorized to U.S. Department of Defense (DoD) and U.S DoD contractors only.
- DISTRIBUTION STATEMENT E: Distribution authorized to U.S. Department of Defense (DoD) components only.
- DISTRIBUTION STATEMENT F: Further dissemination only as directed by the controlling DoD office indicated below or by higher authority.
- DISTRIBUTION STATEMENT X: Distribution authorized to U.S. Government agencies and private individuals or enterprises eligible to obtain export-controlled technical data in accordance with DoD Directive 5230.25, Withholding of Unclassified Technical Data from Public Disclosure, 6 Nov 84.

2d. Reason For the Above Distribution Statement (in accordance with DoD Directive 5230.24)

2e. Controlling Office

HQ AFCEE

2f. Date of Distribution Statement Determination

15 Nov 2000

3. This report is NOT forwarded for the following reasons. (Please check appropriate box)

- It was previously forwarded to DTIC on (date) and the AD number is
- It will be published at a later date. Enter approximate date if known.
- In accordance with the provisions of DoD Directive 3200.12, the requested document is not supplied because:

Print or Type Name

Laura Peña

Signature

Laura Peña

Telephone

210-536-1431

(For DTIC Use Only)

AQ Number

M01-02-0476

CERTIFICATION STATEMENT

I certify under penalty of the law that this document and all attachments were prepared under my direction or supervision in accordance with a system designed to assure that qualified personnel properly gather and evaluate the information submitted. Based on my inquiry of the person or persons who manage the system or those personnel directly responsible for gathering the information, the information submitted is, to the best of my knowledge and belief, true, accurate, and complete. I am aware there are significant penalties for submitting false information, including the possibility of fine and imprisonment for having violations.

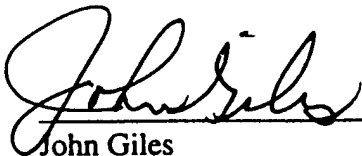

John Giles

Director, Safety & Environmental
Lockheed Aeronautical Systems Company

13 Oct 1993

Date

WORK PLAN CERTIFICATION

I the undersigned, do hereby affirm that the information contained in this work plan is accurate and correct to the best of my knowledge and belief.

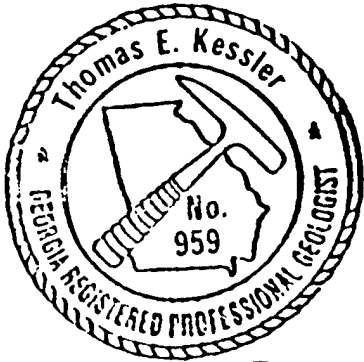

Thomas E Kessler, P.G.
Project Geologist
Engineering Science, Inc.

12 OCTOBER 1993
Date

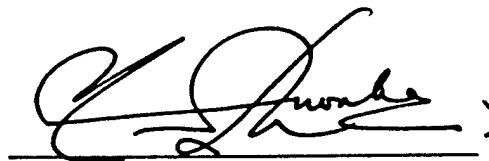
Ola A Awosika
Project Site Manager
Engineering Science, Inc.

October 11, 1993.
Date

BIOVENTING TEST WORK PLAN FOR

AIR FORCE PLANT 6 (AFP 6)
IRP SITE #10 (JP-5 LEAK AREA)

Prepared for

Air Force Center for Environmental Excellence
Brooks AFB, Texas

and

Air Force Plant 6 (AFP 6)
Lockheed-Georgia Company
Marietta, Georgia

by

Engineering-Science, Inc.
57 Executive Park South, NE, Suite 500
Atlanta, Georgia

October 1993

TABLE OF CONTENTS

	Page
1.0 INTRODUCTION	1
2.0 SITE DESCRIPTION	2
2.1 Site Location and History	2
2.2 Site Geology	5
2.3 Site Contaminants	5
3.0 PILOT TEST ACTIVITIES	7
3.1 Introduction.....	7
3.2 Well Siting and Construction.....	7
3.3 Handling of Drill Cuttings.....	9
3.4 Soil and Soil Gas Sampling.....	9
3.4.1 Soil Sampling.....	9
3.4.2 Soil Gas Sampling.....	12
3.5 Blower System	12
3.6 Air Monitoring.....	15
3.7 In Situ Respiration Test.....	15
3.8 Air Permeability Test	16
3.9 Installation of Extended Pilot Test Bioventing System	16
3.10 Availability of Microorganisms	16
4.0 EXCEPTIONS TO PROTOCOL PROCEDURES.....	17
5.0 BASE SUPPORT REQUIREMENTS	17
6.0 PROJECT SCHEDULE	18
7.0 POINTS OF CONTACT.....	18
8.0 REFERENCES	19

- APPENDIX A GENERIC HEALTH AND SAFETY PLAN
- APPENDIX B QUALITY ASSURANCE PROJECT PLAN
- APPENDIX C FIELD SAMPLING PLAN
- APPENDIX D ES ADDENDUM TO TECHNICAL PROTOCOL
- APPENDIX E PROGRAM MANAGEMENT PLAN
- APPENDIX F LABORATORY ANALYTICAL RESULTS
- APPENDIX G EMISSION ISOLATION FLUX CHAMBER METHODOLOGY
- APPENDIX H INJECTION WELL OPERATING PERMIT APPLICATION

LIST OF FIGURES

FIGURE 2.1 SITE LOCATION MAP.....	3
FIGURE 2.2 SITE MAP	4
FIGURE 2.3 CROSS SECTION B-B	6
FIGURE 3.1 PROPOSED VENT WELLS AND VAPOR MONITORING POINTS	8
FIGURE 3.2 AIR FORCE PLANT 6 INJECTION VENT WELL CONSTRUCTION DETAIL.....	10
FIGURE 3.3 AIR FORCE PLANT 6 MONITORING POINT CONSTRUCTION DETAIL.....	11
FIGURE 3.4 SCHEMATIC OF BLOWER SYSTEM FOR AIR INJECTION.....	13
FIGURE 3.5 CONCEPTUAL CROSS-SECTION DESIGN FOR BIOVENTING PILOT TEST OR THE JP-5 LEAK AREA	14

**BIOVENTING TEST WORK PLAN FOR
IRP SITE #10 (JP-5 LEAK AREA)
AIR FORCE PLANT 6
LOCKHEED-GEORGIA COMPANY
MARIETTA, GEORGIA**

1.0 INTRODUCTION

This test work plan presents the scope of an *in situ* bioventing pilot test for treatment of fuel contaminated soils at Air Force Plant (AFP) 6, IRP Site # 10 (JP-5 Leak Area) located at the Lockheed-Georgia Company in Marietta, Georgia. The pilot test has three primary objectives: 1) to assess the potential for supplying oxygen throughout the contaminated soil depth, 2) to determine the rate at which indigenous microorganisms will degrade fuel when stimulated by oxygen rich soil gas, 3) to evaluate the potential for sustaining these rates of biodegradation until fuel contamination is remediated below regulatory standards.

Pilot testing will consist of two phases, an initial air permeability and *in situ* respiration test which will take place in November of 1993, and an extended one year pilot test which will be used to determine the potential for bioventing remediation using natural nutrient levels. The initial and extended pilot test will serve as treatability studies under the CERCLA feasibility study process. If bioventing proves to be feasible at this site, pilot test data may be used to design a full scale remediation system and to estimate the time required for site cleanup.

The initial test will involve air injection at a vent well with a regenerative blower to produce a radius of influence of approximately 30 feet. *In situ* rates of fuel biodegradation and soil gas permeability will be determined during this short term test and a decision on how best to proceed with extended testing will be made with regulatory concurrence.

Additional background information on the development and recent success of the bioventing technology is found in the document entitled *Test Plan and Technical Protocol For A Field Treatability Test For Bioventing* (Hinchee, et al. 1992). A copy of this protocol was submitted to Georgia Environmental Protection Division (GA EPD) on April 1, 1993. The protocol document is a supplement to the site-specific work plan, and it will also serve as the primary reference for pilot test vent well designs and detailed test objectives and procedures. Unless otherwise noted, test procedures outlined in the protocol document will be used during the pilot tests at AFP 6. Other scoping documents

designed to clearly define project activities before implementation are provided in the appendices to this work plan for reference purposes. These documents include a generic Health and Safety Plan (Appendix A), Quality Assurance Project Plan (Appendix B), Field Sampling Plan (Appendix C), ES Addendum to the Protocol (Appendix D), Program Management Plan (Appendix E), Laboratory Analytical Results (Appendix F), a description of the Emission Isolation Flux Chamber Methodology (Appendix G), and the Injection Well Operating Permit Application (Appendix H).

2.0 SITE DESCRIPTION

2.1 Site Location and History

The JP-5 Leak Area is located near the southern central portion of the Lockheed-Georgia Company in Marietta, Georgia (Figure 2.1). The Lockheed industrial waste treatment facility is located north of the site and Dobbins Air Force Base is located to the south. The topography in the site area slopes from the northwest to the southeast. The difference in elevation across the site is approximately 15 feet. Surface cover at the site consists of exposed grass and native soil. A site map is provided in Figure 2.2.

The site area is used as an unloading area for jet fuel. Jet fuel is transported to the site primarily by tank trucks and occasionally by rail cars. The fuel is then transferred by a pipeline to a tank farm located several thousand feet northwest of the site.

The pipeline leading from the fuel unloading area to the tank farm ruptured in late December 1980 resulting in the loss of approximately 24,000 gallons of JP-5 jet fuel. At the leak location, numerous small leak areas and one hole were detected along a twenty foot section of fuel pipe. The fuel pipe is buried between five to seven feet below ground surface (BGS). Following the rupture, some of the fuel migrated to the ground surface and flowed overland to a lake approximately 2,500 feet away. Approximately 1,000 gallons of JP-5 were recovered from the surface of the lake.

Two environmental investigations have been performed at the JP-5 Leak Area. The first investigation was performed by LAW Engineering Testing Company (LAW) in March 1981, and the second investigation was performed by Geo-Hydro Engineers, Inc. (Geo-Hydro) in August of 1992.

The investigation performed by LAW involved the installation of soil borings and monitoring wells to assess the subsurface geology, and to determine the vertical and horizontal extent of hydrocarbons in the soil and groundwater. As part of the investigation conducted by LAW, fifteen soil borings were drilled and seven borings were completed as monitoring wells. In addition, several hand auger borings were advanced to determine the approximate extent of JP-5 contamination at the surface. Groundwater was also analyzed from the new wells and an existing observation well (A-1) located on site.

SITE LOCATION MAP LOCKHEED-GEORGIA COMPANY MARIETTA, GEORGIA

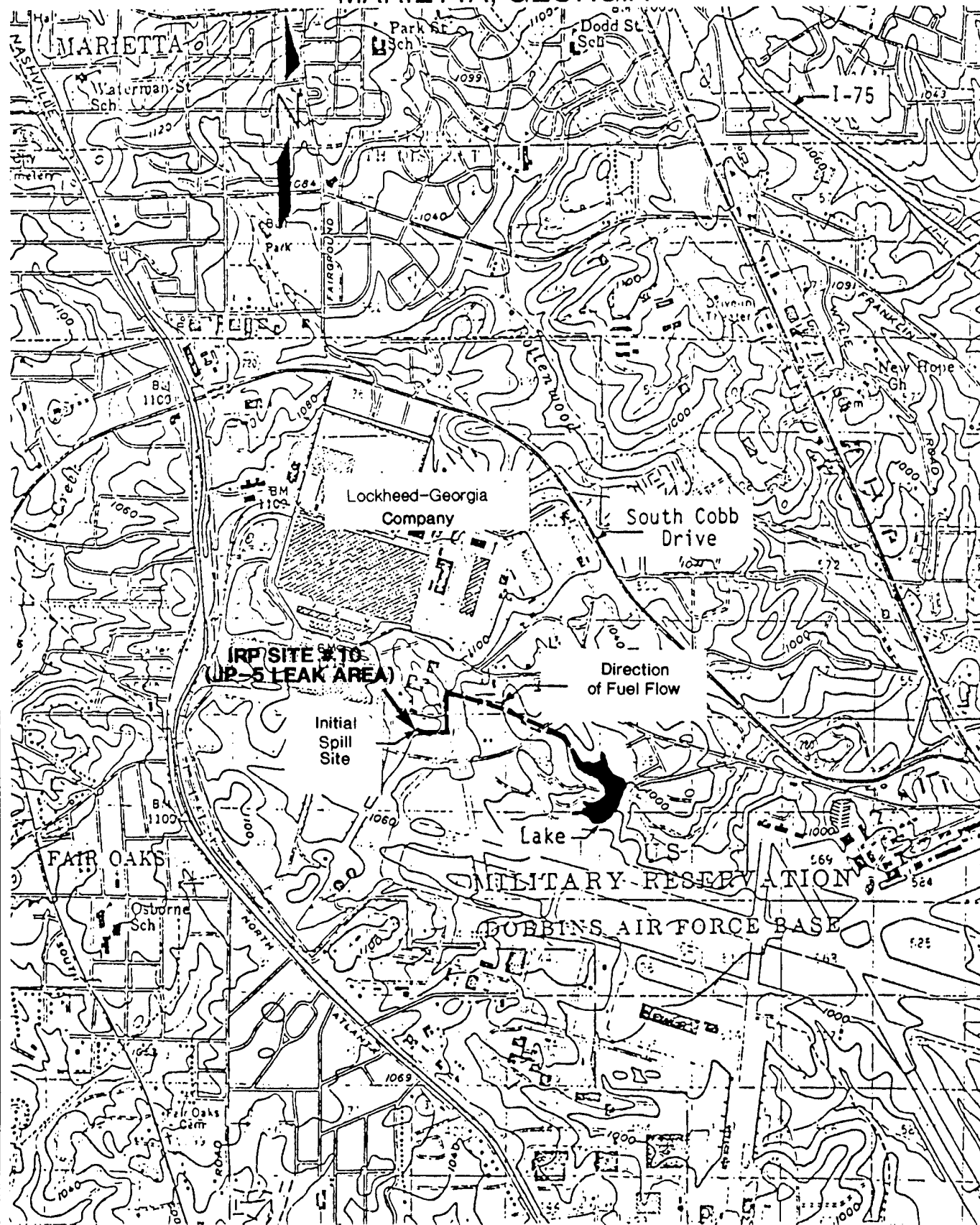

Source: Law Engineering Testing Company, 1981.

SCALE - 1" = 24,000'

Figure 2.2

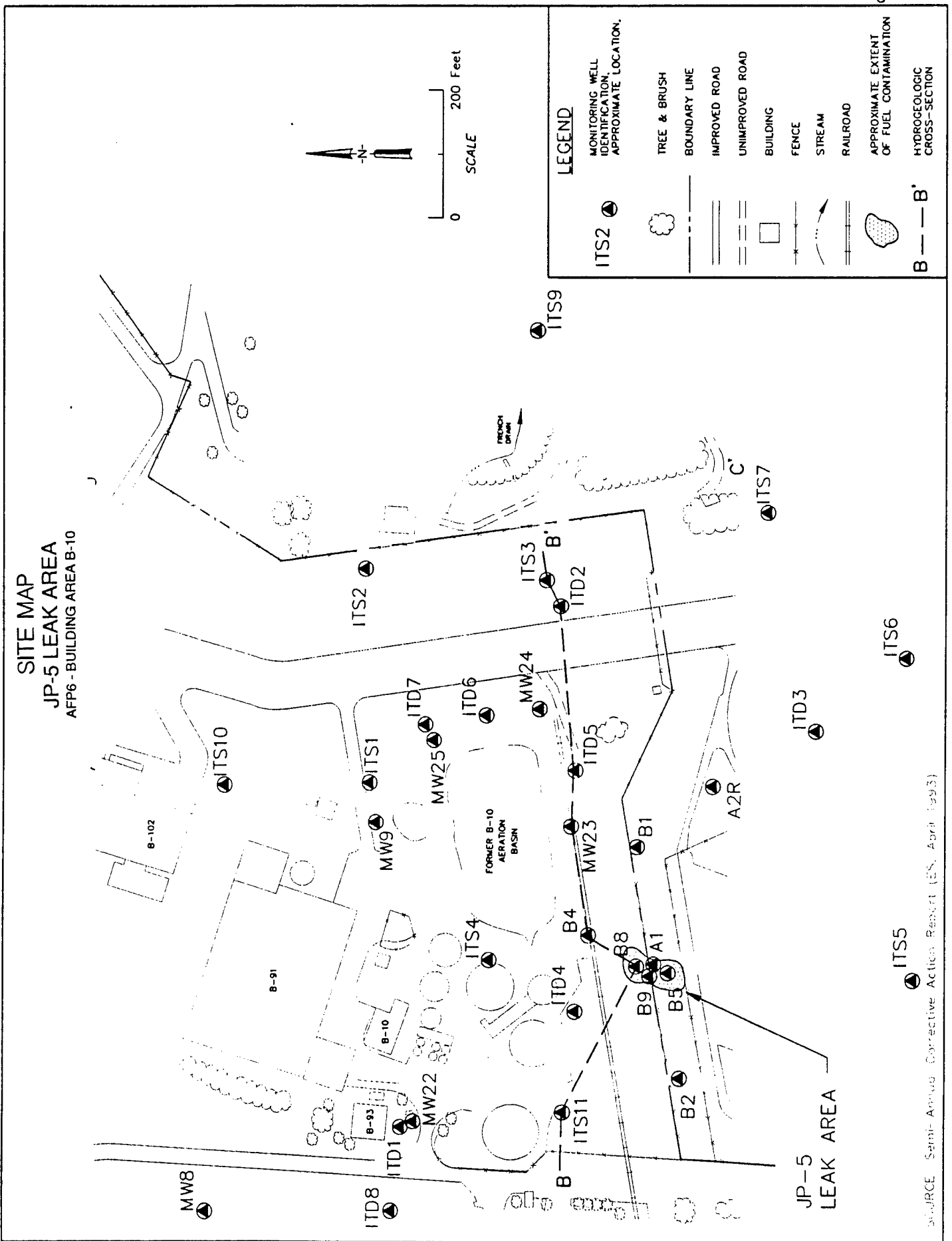

SOURCE: Semi-Annual Corrective Action Report (ES, April 1993)

CROSS-SECTION B-B' - BUILDING AREA B-10 AFP6

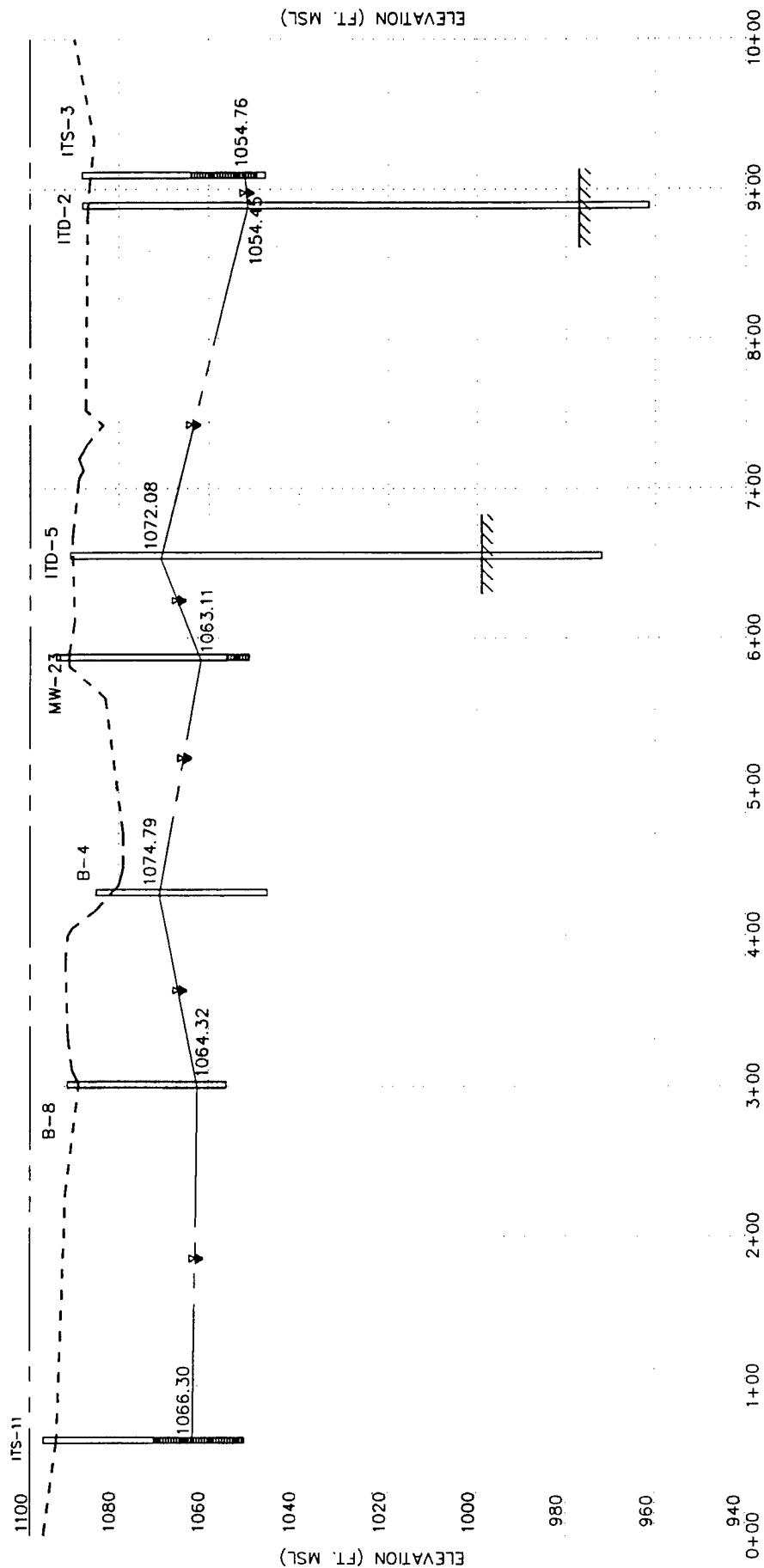

SECTION B-B'

SCALES: HORIZ. 1"=110'; VERT. 1"=20'

LEGEND

- EXISTING GROUND
- ▽- WATER TABLE
- /// BEDROCK

Figure 2.3

SOURCE: Semi-Annual Corrective Action Report (E.S. April 1993)

This boring is located adjacent to well B5 (installed by LAW in March 1981), and is approximately 40 feet south and downgradient of the pipeline leak. The laboratory analytical results are included in Appendix F.

Benzene, toluene, ethylbenzene, and xylenes (BTEX) concentrations in the soil samples ranged from below detection limits to a maximum total BTEX concentration of 27.5 ppm. Groundwater samples collected during the investigation performed by Geo-Hydro did not detect hydrocarbons in groundwater beneath the site.

3.0 PILOT TEST ACTIVITIES

3.1 Introduction

The purpose of this section is to describe the work that will be performed by Engineering-Science, Inc. (ES) at IRP Site #10. Activities performed at the site will include siting and construction of a central vent well (VW) and three vapor monitoring points (VMPs); an *in situ* respiration test; an air permeability test; and the installation of an extended bioventing pilot test system. Soil and soil gas sampling procedures and blower configuration that will be used to inject air (oxygen) into contaminated soils are also discussed in this section. In an effort to be as cost effective as possible, a single VW will be completed to the depth of lowest seasonal groundwater at the site. Pilot test activities will be confined to unsaturated soils remediation. Existing monitoring wells will not be used as primary air injection or extraction wells. However, monitoring wells which have a portion of their screened interval above the water table may be used as VMPs or to measure the composition of background soil gas. Existing monitoring wells at Site #10 may also be monitored during air permeability testing.

3.2 Well Siting and Construction

A general description of criteria for siting a single central VW and associated VMPs at IRP Site #10 are included in the attached protocol document. Figure 3.1 illustrates the proposed location of the central VW and VMPs at Site #10. The final location of the VW may vary slightly from the proposed location if significant fuel contamination is not observed in the boring for the central VW. Based on previous site investigation data, the VW will be located between wells A1, B5, and B9. The area is expected to have an average TPH concentration exceeding 3,000 ppm. Soils in this area are expected to be oxygen depleted (<2%) and increased biological activity should be stimulated by oxygen-rich soil gas ventilation during full-scale operations.

Due to the relatively deep depth of contamination at this site and the potential for moderate permeability soils, the radius of venting influence around the central air injection well in the pit is expected to exceed 30 feet. Three VMPs will be located within a 30-foot radius of the central VW. Background monitoring for this test will be conducted at either an existing background monitoring point or at a background vapor monitoring point located approximately 300 feet northwest of the leak area. Well ITS-11 is a potential candidate for the background well. The location of this well is shown on

PROPOSED VENT WELL AND VAPOR MONITORING POINTS
AFP6 - JP-5 LEAK AREA

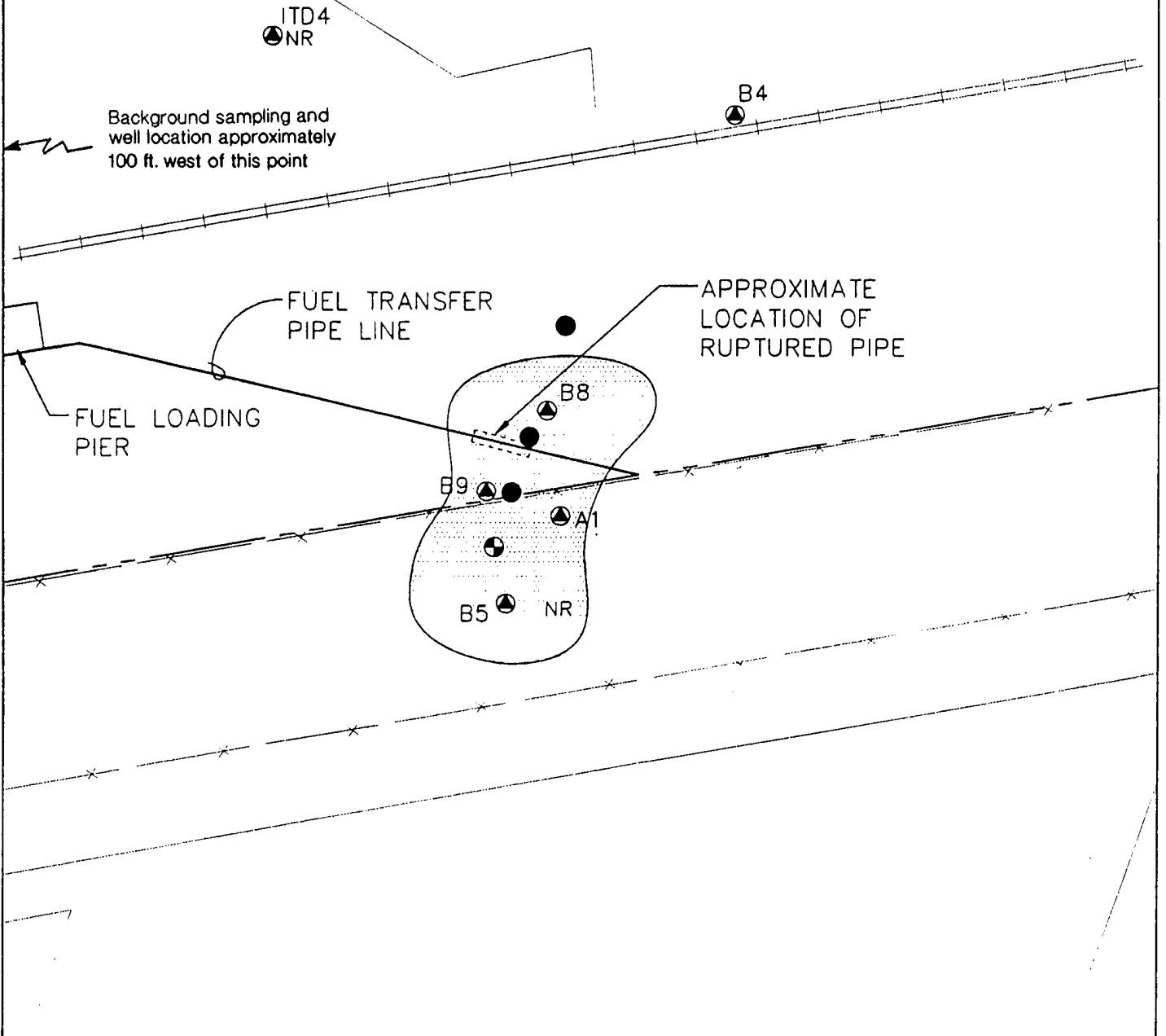

LEGEND

ITS2	MONITORING WELL IDENTIFICATION, APPROXIMATE LOCATION.		BUILDING
	TREE & BRUSH		FENCE
	BOUNDARY LINE		STREAM
	IMPROVED ROAD		RAILROAD
	UNIMPROVED ROAD	ITD3 NR	SAMPLE COLLECTION NOT REQUIRED AT THE MONITORING WELL
	VENT WELL (VW)		
	VAPOR MONITORING POINT (VMP) SET AT 15', 30' AND 60' FROM VW		EXTENT OF SURFACE FUEL CONTAMINATION

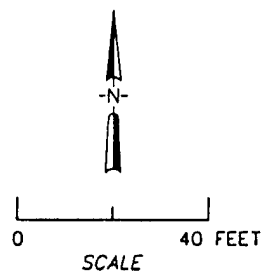

N:\DE268\CADD\SITE-1, 06/04/93 at 17:17

Figure 2.2 and 2.3. If a background vapor monitoring well has to be installed, it will be constructed in the vicinity of well ITS-11 during the initial field work. The background well would be used to measure background levels of oxygen and carbon dioxide and to determine if natural carbon sources are contributing to oxygen uptake during the *in situ* respiration test.

The VW will be constructed of 4-inch ID Schedule 40 PVC, with a 20-foot interval of 0.04 slotted screen set between 6 and 26 feet BGS (groundwater occurs at depths between 24 and 28 feet below ground surface). Flush-threaded PVC casing and screen will be used with no organic solvents or glues. The filter pack will be clean, well-rounded silica sand with a 8-12 grain size and will be placed in the annular space of the screened interval. A 3-foot layer of bentonite will be placed directly over the filter pack. The bentonite will consist of granular bentonite and/or pellets hydrated in place with potable water to produce an air tight seal above the screened interval. A complete seal is critical to prevent injected air from short-circuiting to the surface during the bioventing test. Silica sand and cement grout will placed over the slurry and extend to the ground surface. Figure 3.2 illustrates the proposed central VW construction details for this site.

A typical multi-depth VMP installation for this site is shown in Figure 3.3. Soil gas oxygen and carbon dioxide concentrations will be monitored at depth intervals of approximately 5 to 6 feet, 14 to 15 and 23 to 24 feet at each location (the deepest monitoring point will be set at approximately 3 feet above the deepest seasonal groundwater elevation). Multi-depth monitoring will confirm that the entire soil profile is receiving oxygen and be used to measure fuel biodegradation rates at all depths. The annular space between these three monitoring points will be sealed with bentonite to isolate the monitoring intervals. As with the central vent well, granular bentonite or pellets will be used to create the air tight seal between discreet depth monitoring points. Additional details on VW and monitoring point construction are found in Section 4 of the protocol document and the addendum provided in Appendix D.

3.3 Handling of Drill Cuttings

Soil cuttings obtained during monitoring point and vent well construction will be drummed, labeled, and stored onsite pending evaluation of final disposal option by the Plant 6 point of contact.

3.4 Soil and Soil Gas Sampling

3.4.1 Soil Sampling

Three soil samples will be collected during the pilot test at the time of VW and VMP installation. One sample will be collected from the most contaminated interval of the central VW boring and one sample will be collected from the interval of highest apparent contamination in two of the borings drilled for VMP installations. Soil samples will be analyzed for TPH, BTEX, soil moisture, pH, particle sizing, alkalinity, total iron and nutrients.

INJECTION VENTING WELL CONSTRUCTION DETAIL

Air Force Plant 6, Georgia

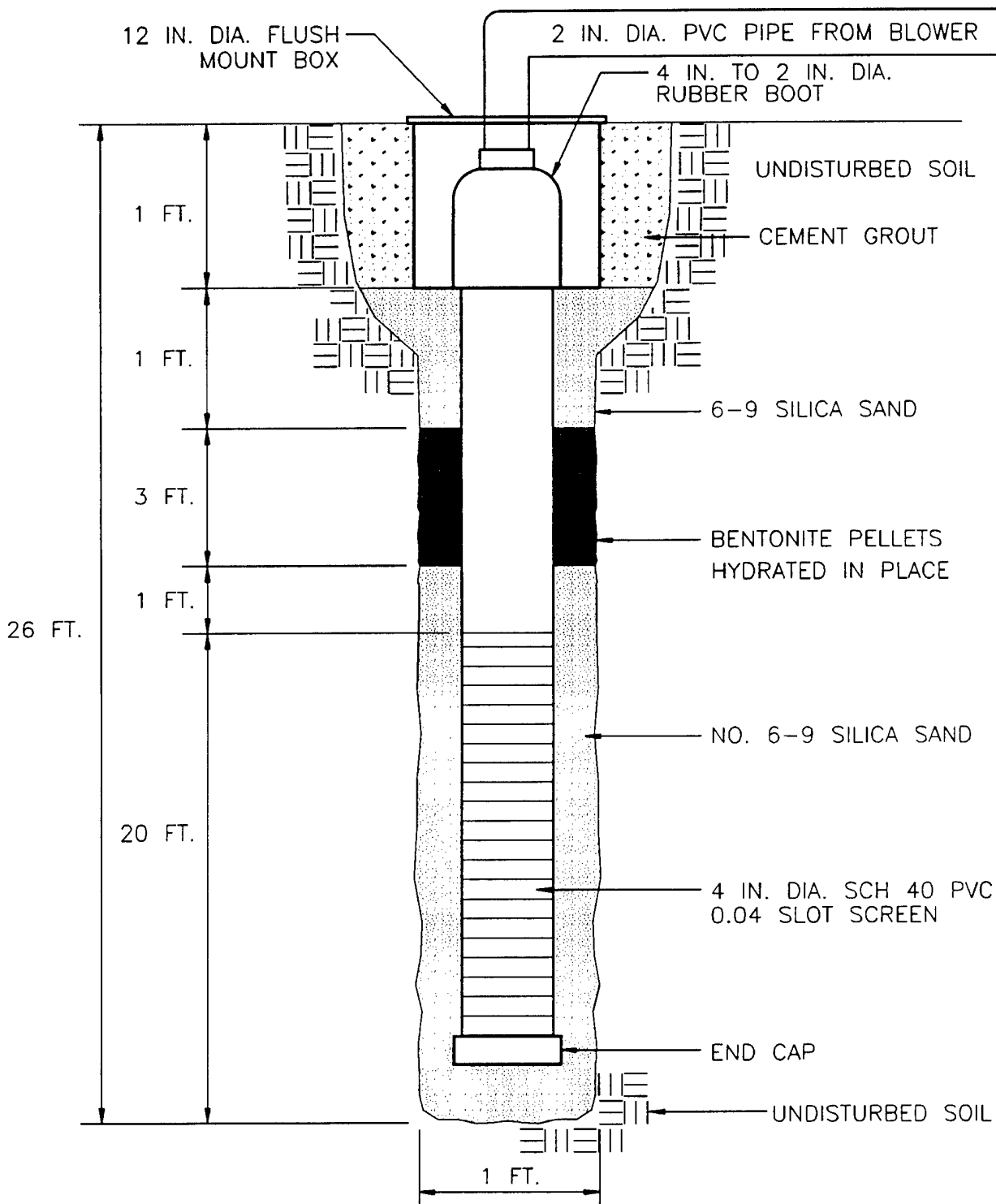

Not To Scale

N:\AT808\CADD\WELL-1, 06/04/93 at 13:35

TYPICAL MONITORING POINT CONSTRUCTION DETAIL

Air Force Plant 6, Georgia

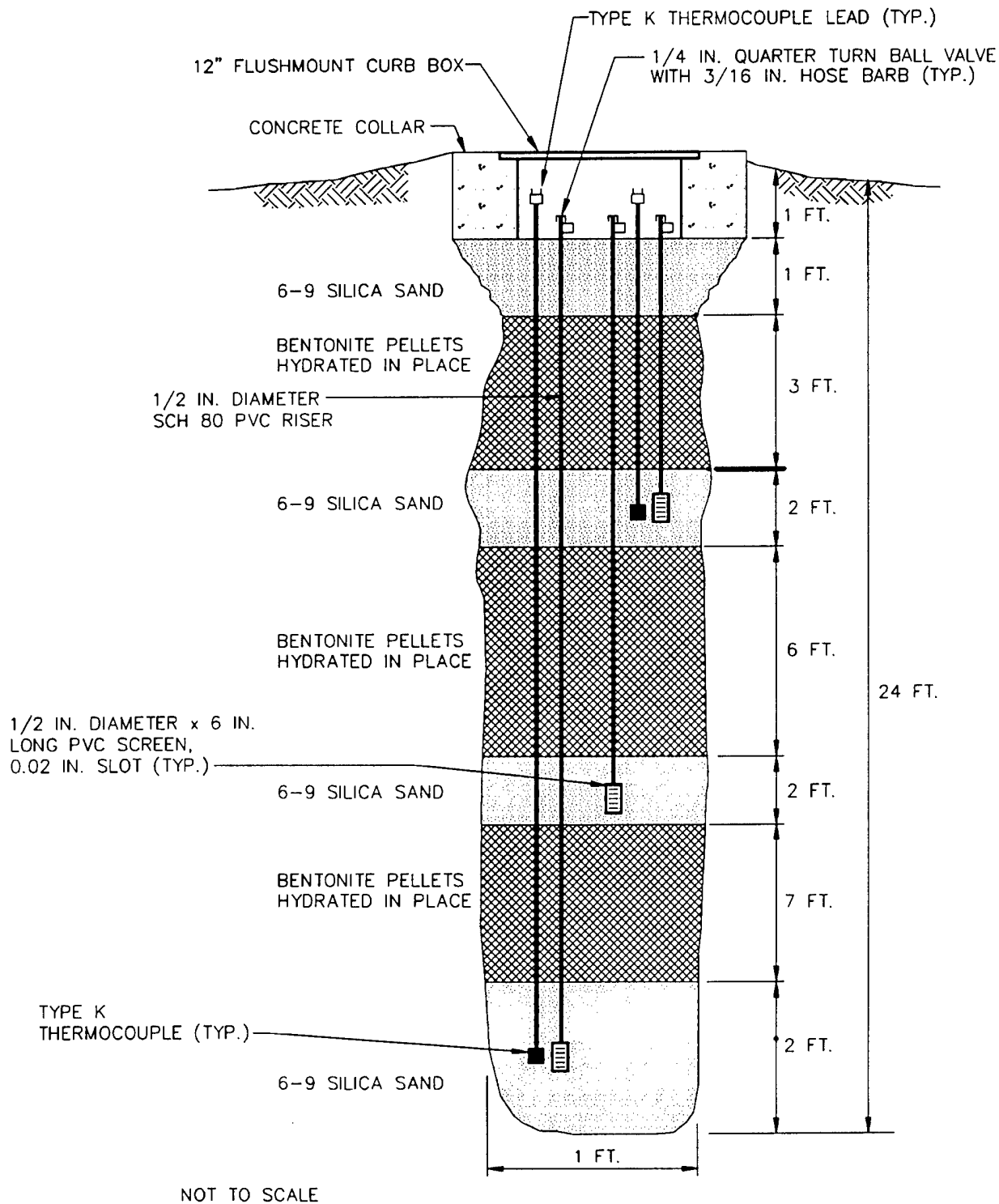

N:\AT808\CADD\WELL2, 06/04/93 at 13:47

Samples will be collected using a split-spoon sampler containing brass tube liners. A photoionization detector or total hydrocarbon vapor analyzer (see protocol Section 4.5.2) will be used to insure that breathing zone levels of volatiles do not exceed 1 ppm during drilling and to screen split spoon samples for intervals of high fuel contamination. Soil samples collected in the brass tubes will be immediately trimmed and aluminum foil and a plastic cap placed over the ends. Soil samples will be labeled following the nomenclature specified in the protocol document (Section 5.5), wrapped in plastic, and placed in an ice chest for shipment. A chain of custody form will be filled out and the ice chest shipped to the Pace Laboratory in Novato, California, for analysis. This laboratory has been audited by the U.S. Air Force and meets all quality assurance/quality control and certification requirements for the State of California.

3.4.2 Soil Gas Sampling

A total of three soil gas samples will be collected in SUMMA™ canisters in accordance with the *Bioventing Field Sampling Plan* (ES, 1992) (Appendix C). The samples will be collected from the VW, and from the VMPs closest to and furthest from the VW at the site. These soil gas samples will be used to predict potential air emissions, to determine the reduction in BTEX and total volatile hydrocarbons (TVH) during the 1-year test, and to detect any migration of these vapors from the source area.

Soil gas sample canisters will be placed in a small cooler and packed with foam pellets to prevent excessive movement during shipment. Samples will not be sent on ice to prevent condensation of hydrocarbons. A chain-of-custody form will be filled out, and the cooler will be shipped to the Air Toxics laboratory in Folsom, California for analysis. The procedure for collecting these samples are presented in the Field Sampling Plan (FSP) (Appendix C, Section C.2). Sample analysis, type, number, container, and preservatives are also presented in Table C.1 in the FSP.

3.5 Blower System

A 1.0-HP blower capable of injecting 30 - 60 scfm will be used to conduct the initial air permeability test. This blower provides a wide range of flow rates and should develop sufficient pressure to move air through moderate permeability soils. Air injection will be used to provide oxygen to soil bacteria and to minimize emissions of volatiles to the atmosphere. If initial testing at the site indicates that less pressure is required to supply oxygen, a smaller blower will be installed for extended testing (1 year pilot test)..

An extended pilot test will be performed if results of initial pilot testing indicate oxygen utilization rates that confirm presence of biological activity is positive. The extended bioventing test will be initiated following a review of initial test data and regulatory approval. Figure 3.4 is a schematic of a typical air injection system that will be used for pilot testing at these sites. A conceptual cross section design for the bioventing system at the JP-5 Leak Area is depicted on Figure 3.5.

SCHEMATIC OF BLOWER SYSTEM FOR AIR INJECTION
JP-5 LEAK AREA
 AIR FORCE PLANT 6, GEORGIA

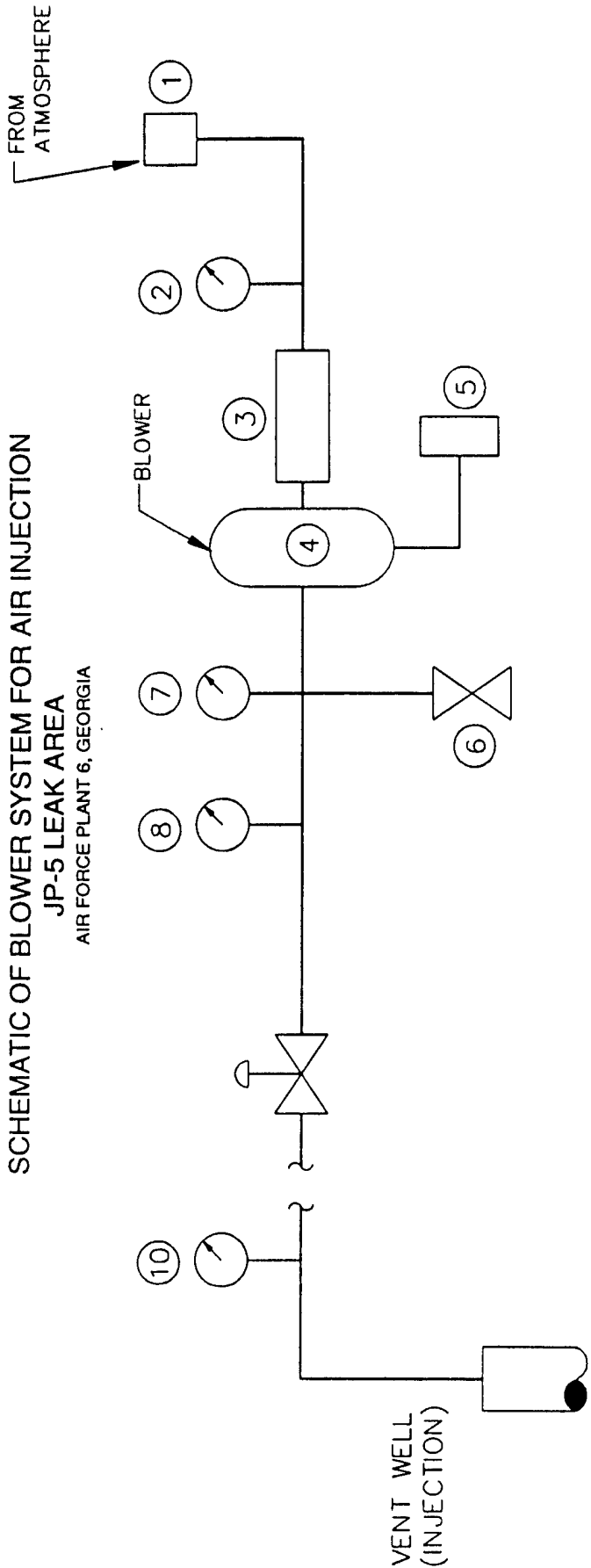

- ① INLET FILTER
- ② VACUUM GAUGE (INCHES OF H O)
- ③ DRIVE MOTOR
1 HP / 3450 RPM @ 60 Hz / 230v / SINGLE PHASE / 15 A
- ④ BLOWER - GAST R4110-2 / REGENERATIVE
70 SCFM @ 20 INCHES H O
- ⑤ POWER SWITCH
- ⑥ AUTOMATIC PRESSURE RELIEF VALVE - SET @ 42 INCHES H O
- ⑦ PRESSURE GAUGE (INCHES OF H O)
- ⑧ THERMOMETER (FAHRENHEIT)
- ⑨ MANUAL PRESSURE RELIEF (BLEED) VALVE - 1 1/2" BALL
- ⑩ AIR VELOCITY MEASUREMENT PORT

CONCEPTUAL CROSS-SECTION DESIGN FOR
BIOVENTING PILOT TEST AT THE JP-5 LEAK AREA
AF PLANT-6

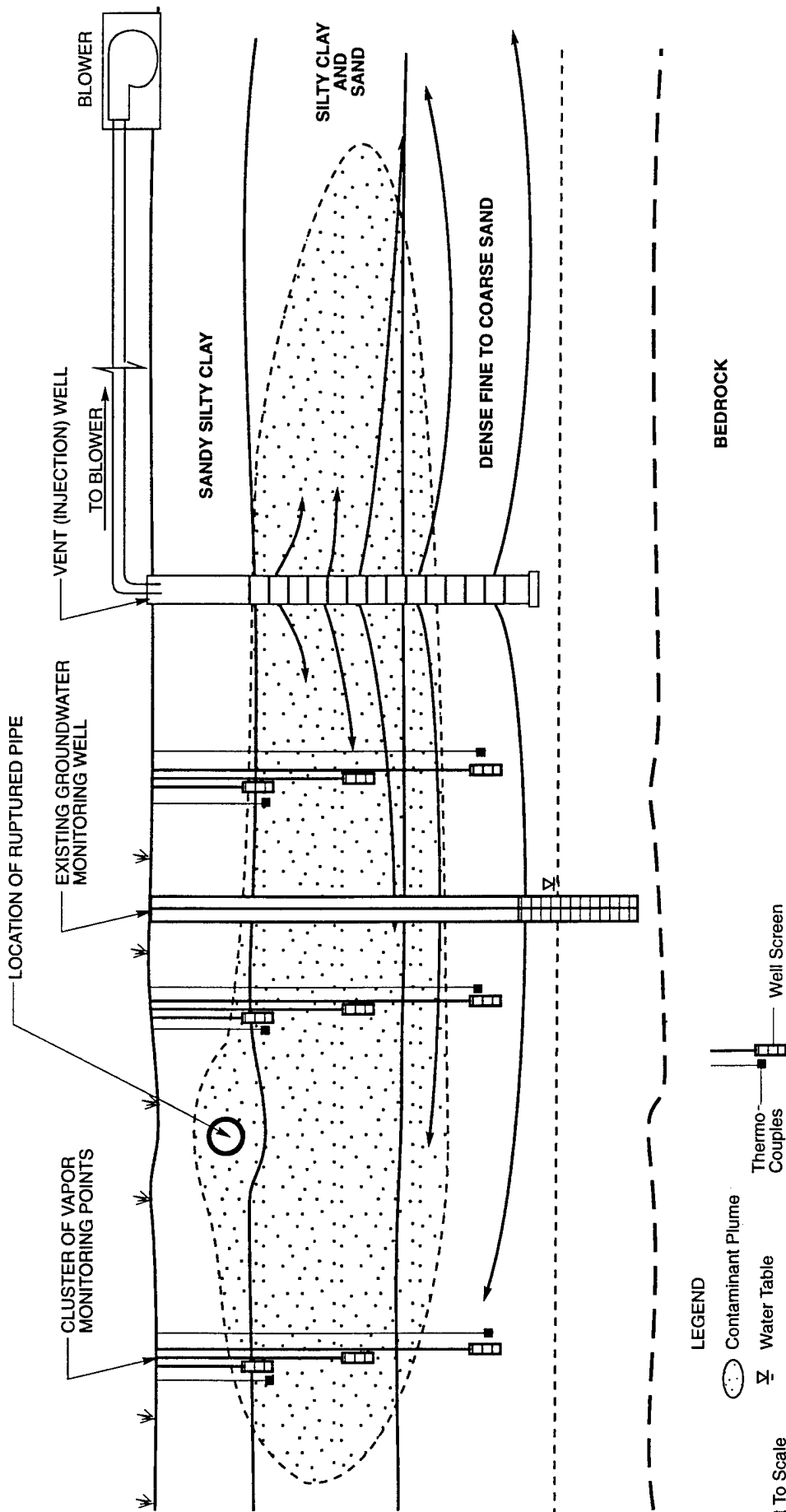

Not To Scale

6/DE288-2/CD/0993

The maximum power requirement anticipated for this pilot test is a 230-volt, single-phase, 30-amp service. Additional details on power supply requirements are described in Section 5.0, Base Support Requirements.

3.6 Air Monitoring

The bioventing technique will minimize total emissions of more volatile hydrocarbons to the atmosphere. This is accomplished by reducing air injection rates to supply only the minimum required oxygen to sustain the indigenous microorganisms. By supplying only the required oxygen for biodegradation, volatilization effects caused by excess air injection is minimized.

During all activities involving air injection, the air at the ground surface and at the breathing zone within a 20 foot radius of the injection well will be monitored for volatile hydrocarbons by use of a photoionization detector. Air monitoring will be done to ensure safe working conditions and to provide a rough estimate of volatilization losses, if they occur. More intense air monitoring is required during the first eight hours of the air permeability test because the potential for emissions of the more volatile hydrocarbons is greatest at that time.

The potential for emissions at the JP-5 Leak Area is minimal because of the age of the fuel residuals (13 years). Flux emissions measured at a similar site at another Air Force base with similar aged contaminants and silty clay soils showed less than 5 grams of fuel hydrocarbons emitted to the atmosphere per hour of operation, or less than 0.26 pounds per day. To determine if contaminants are being released to the atmosphere on-site flux emission measurements will be made during the initial and extended testing. A description of the method and equipment that will be used for the flux emission measurements is included in Appendix G.

3.7 In Situ Respiration Test

The objective of the *in situ* respiration test is to determine the rate at which soil bacteria degrade petroleum hydrocarbons in the presence of oxygen. Respiration tests will be performed at the three VMP points with the highest apparent fuel contamination at the site. Air will be injected into each VMP depth interval containing low levels (<2%) of oxygen. A 20 to 24-hour air injection period will be used to oxygenate local contaminated soil. At the end of the air injection period, the air supply will be cut off, and oxygen and carbon dioxide levels will be monitored for five days or until the oxygen level falls below 5 %, whichever is earlier. The decline in oxygen and increase in carbon dioxide concentrations over time will be used to estimate rates of bacterial degradation of fuel residuals.

Concurrent to the air injection period, a helium tracer will also be injected at the VMPs at a concentration of two to five percent. Helium levels will be monitored along with the oxygen and carbon dioxide levels to ensure that the VMPs do not leak.

Additional details on the *in situ* respiration test are found in Section 5.7 of the protocol document.

3.8 Air Permeability Test

The objective of the air permeability test is to determine the extent of the subsurface that can be oxygenated using one air injection VW. Air will be injected into the 4-inch-diameter VW using the blower unit, and pressure response will be measured at each VMP with differential pressure gauges to determine the region influenced by the unit. Oxygen will also be monitored in the VMPs to verify that oxygen levels in the soil increase as the result of air injection. One air permeability test lasting 4 to 8 hours will be performed.

3.9 Installation of Extended Pilot Test Bioventing System

An extended, 1-year bioventing pilot system will be installed at the JP-5 Leak Area. The decision to proceed with the bioventing pilot system for a year will be based on the results of the degradation rate calculations. From previous studies, the oxygen utilization rates that can be expected from sites contaminated with jet fuel are between 0.05 to 1.0% O₂/hour. If rates within this range are obtained and are significantly greater than background, there is sufficient evidence to assume that some microbial activity is occurring and that the addition of O₂ in these contaminated areas will enhance biodegradation. If soil gas O₂ levels are above 2 to 5% prior to any air injection, or if oxygen utilization rates are not greater than background, venting will most probably not stimulate biodegradation and consideration will be given to terminate the bioventing effort.

The base will be requested to provide a power pole with a 230-volt, single-phase, 30-amp breaker box. Two 115-volt receptacles will also be required. Depending on the availability of a base electrician, a base electrician or a licensed electrician subcontracted to ES will assist in wiring the blowers to line power. The blower will be housed in a small, prefabricated shed to provide protection from the weather.

The system will be in operation for 24-hours per day for 1 year. Air injection rates of less than 30 SCFM are anticipated at the site. After six months and 12 months of operation, ES personnel will conduct follow-up *in situ* respiration tests to monitor the long-term performance of this bioventing system. Weekly system checks will be performed by Lockheed personnel. If required, major maintenance of the blower unit may be performed by ES personnel. Detailed blower system information and a maintenance schedule will be included in the operation and maintenance (O&M) manual provided to the base. More detailed information regarding the test procedures can be found in the protocol document.

3.10 Availability of Microorganisms

No microbial population study has been conducted at the JP-5 Leak Area. However, microbial communities composed of bacteria that would degrade fuel residuals are

expected at the site. The type of bacteria expected is pseudomonas. The parameters of interest in JP-5 are benzene, toluene, ethylbenzene, and xylene (BTEX) and TPH. On the basis of available analytical results and bioventing studies in soils of similar contamination, the concentrations of these compounds will not be toxic to these organisms.

4.0 EXCEPTIONS TO PROTOCOL PROCEDURES

The procedures that will be used to measure the air permeability of the soil and *in situ* respiration rates are described in Sections 4 and 5 of the protocol document. No exceptions to this protocol are anticipated.

5.0 BASE SUPPORT REQUIREMENTS

The following base support is needed prior to the arrival of a driller and the ES test team:

- Confirmation of regulatory approval for the pilot test.
- Assistance in obtaining a digging permit at the site.
- A breaker box or generator within 50 feet of the proposed VW which can supply 230-volt, single-phase, 30-amp service for the initial and extended pilot test. This service will be supplied from a central breaker box situated in the area of the fire training pits.
- Provision of any paperwork required to obtain gate passes and security badges for approximately four ES employees and two drillers. Vehicle passes will be needed for two trucks and a drill rig.

During the initial three week pilot test the following base support is needed:

- Twelve square feet of desk space and a telephone in a building located as near to the site as practical.
- The use of a fax machine for transmitting 15 to 20 pages of test results.

During the one year extended pilot test the following base support is needed:

- Check the blower system at Site #10 at least once a week to ensure that it is operating and to record the air injection pressure. Engineering-Science will provide a brief training session on this procedure.
- Notify Mr. Ola Awosika (404) 235-2371, ES-Atlanta, or Mr. David Brown, ES-Syracuse, (315) 451-9560; or Mr. Sam Taffinder of the AFCEE, (210) 536-4366, if the blower or motor stop working.
- Arrange site access for an ES technician to conduct *in situ* respiration tests approximately six months and one year after the initial pilot test.

6.0 PROJECT SCHEDULE

The following schedule is contingent upon timely approval of this pilot test work plan.

Event	Date
Final Test Work Plan to AFCEE & GA EPD	October 15, 1993
Regulatory Approval	October 29, 1993
Begin Pilot Test	November 15, 1993
Complete Initial Pilot Test	November 19, 1993
Interim Results Report	January 14, 1994
Six Month Respiration Test	June 1994
Final Respiration Test	December 1994

7.0 POINTS OF CONTACT

Mr. Richard Rexrode
Lockheed-Georgia Company
Department 49-52, Zone 0444
Marietta, Georgia 30063
(404) 494-2417

Ms. Rita Chan
ASC/EMVR
2060 3rd Street, Bldg 17
Wright Patterson AFB OH 45433-7203
DSN 785-4151/5855
(513) 255-4151/9985

Lt. Colonel Ross Miller/Mr. Sam Taffinder
AFCEE/ESR/ESCT
Brooks AFB, Texas 78235-5000
(210) 536-4331/(210) 536-4366

Mr. Dave Brown
Engineering-Science, Inc
290 Elwood Davis Road, Suite 312
Liverpool, New York 13088
(315) 451-9560 Fax.(315) 451-9570

Mr. Ola Awosika
Engineering-Science, Inc.
57 Executive Park South, NE, Suite 500
Atlanta, Georgia 30329
(404) 235-2371 Fax (404) 235 2500

8.0 REFERENCES

Engineering-Science, Inc. 1992. Project Management Plan for AFCEE Bioventing, Appendix D, Field Sampling Plan. Denver, Colorado. April.

Geo-Hydro Engineers, Inc., 1992. Letter Report "Lockheed Georgia Company Environmental Testing Area JP-5 LEAK AREA and Area G-12 Marietta, Georgia.

Hinchee, R.E., S.K. Ong, R.N. Miller, D.C. Downey, R. Frandt. 1992. Test Plan and Technical Protocol for a Field Treatability Test for Bioventing. Columbus, Ohio. January.

Law Engineering Testing Company, 1981. Report of Subsurface Fuel Contamination Study Lockheed-Georgia Company, Marietta, Georgia.

APPENDIX A
GENERIC HEALTH AND SAFETY PLAN

**PROGRAM HEALTH AND SAFETY PLAN
FOR
BIOVENTING TEST INITIATIVE**

Prepared for:

**AIR FORCE CENTER FOR ENVIRONMENTAL EXCELLENCE (AFCEE)
ENVIRONMENTAL RESTORATION DIVISION (ESR)
BROOKS AIR FORCE BASE, TEXAS 78235-5000**

USAF CONTRACT F33615-90-D-4014, DELIVERY ORDER 14

June 1992

Prepared by:

**ENGINEERING-SCIENCE, INC.
1700 Broadway, Suite 900
Denver, Colorado 80290**

Reviewed and Approved By:

	Name	Date
Project Manager		<u>29 Dec 92</u>
Office H & S Representative		<u>12/29/92</u>

TABLE OF CONTENTS

	Page
SECTION 1 PURPOSE AND POLICY	1-1
SECTION 2 PROJECT DESCRIPTION AND SCOPE OF WORK	2-1
2.1 Project Description	2-1
2.2 Scope of Work	2-1
SECTION 3 PROJECT TEAM ORGANIZATION	3-1
SECTION 4 SITE-SPECIFIC EMPLOYEE TRAINING AND MEDICAL MONITORING REQUIREMENTS	4-1
4.1 Additional Safety Training Requirements	4-1
4.2 Additional Medical Monitoring Requirements	4-1
SECTION 5 SAFETY AND HEALTH RISK ANALYSIS	5-1
5.1 Chemical Hazards	5-1
5.2 Physical Hazards	5-1
5.2.1 Heat Stress	5-1
5.2.2 Other Physical Hazards	5-1
SECTION 6 EMERGENCY RESPONSE PLAN	6-1
6.1 Guidelines for Pre-Emergency Planning and Training	6-1
6.2 Emergency Recognition and Prevention	6-1
6.3 Electrical Safety	6-2
6.3.1 General Electrical Safety Rules	6-3
6.3.2 Holding and Locking Out Electrical Circuits	6-4
6.4 Fire Safety	6-4
6.5 Physical Hazards	6-5
6.5.1 Motor Vehicles and Heavy Equipment	6-5
6.5.2 Slip, Trip and Fall Hazards	6-5
6.5.3 Excavation Activities	6-6
6.5.4 Drilling Accidents	6-6
6.5.5 Subsurface Hazards	6-6
6.5.6 Electrical Line Clearance and Thunderstorms	6-6
6.5.7 Noise-induced Hearing Loss	6-7
6.6 Personnel Roles, Lines Of Authority, And Communication Procedures During An Emergency	6-7
6.7 Evacuation Routes And Procedures, Safe Distances, And Places Of Refuge	6-7
6.8 Decontamination Of Personnel During An Emergency	6-7
6.9 Emergency Site Security And Control	6-8

**TABLE OF CONTENTS
(CONTINUED)**

	Page
6.10 Procedures For Emergency Medical Treatment And First Aid	6-8
6.10.1 Chemical Exposure	6-8
6.10.2 Personal Injury	6-8
6.10.3 Fire or Explosion	6-9
6.10.4 Emergency Contacts	6-9
SECTION 7 LEVELS OF PROTECTION AND PERSONAL PROTECTIVE EQUIPMENT REQUIRED FOR SITE ACTIVITIES	7-1
7.1 Personal Protective Equipment	7-1
7.2 Equipment Needs	7-1
7.3 Heat Stress	7-2
7.3.1 Effects of Heat Stress	7-2
7.3.2 Heat-Related Problems	7-2
7.3.3 Heat Stress Monitoring	7-3
SECTION 8 FREQUENCY AND TYPES OF AIR MONITORING	8-1
SECTION 9 SITE CONTROL MEASURES	9-1
9.1 Site Organization-Operation Zones	9-1
9.1.1 Exclusion Zone (Contamination Zone)	9-1
9.1.2 Contamination Reduction Zone	9-2
9.1.3 Support Zone	9-2
9.2 Site Security	9-2
9.3 Site Communication	9-2
9.4 Safe Work Practices	9-2
SECTION 10 DECONTAMINATION PROCEDURES	10-1
10.1 Personnel Decontamination Procedures	10-1
10.2 Decontamination Of Equipment	10-1
SECTION 11 AIR MONITORING EQUIPMENT USE AND CALIBRATION PROCEDURES	11-1
11.1 Photovac TIP® Air Analyzer	11-1
11.2 HNu® Photoionization Detector	11-1
11.3 Total Volatile Hydrocarbon Analyzer	11-1
11.4 Sensidyne® or Draeger® Colorimetric Gas Analysis Tubes (Benzene Specific)	11-2
APPENDIX A EMERGENCY CONTACTS	
APPENDIX B PROJECT HEALTH AND SAFETY FORMS	

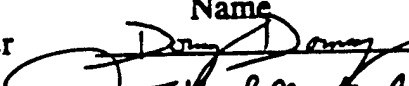
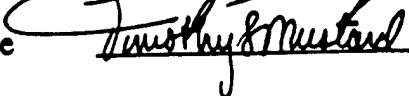
SECTION 1

PURPOSE AND POLICY

Engineering-Science, Inc. (ES) has prepared this program health and safety plan to conduct bioventing pilot tests at U.S. Air Force sites contaminated with petroleum hydrocarbons. The purpose of this plan is to establish personnel protection standards and mandatory safety practices for the installation/construction and monitoring of these systems. The plan also provides for contingencies that may arise during field operations. All ES personnel and subcontractors who engage in field activities will be familiar with this plan and comply with its requirements. This plan provides guidance for general operations on bioventing sites. Site-specific information is not provided in this plan and will be addressed in formal health and safety plan addenda.

A project description and scope of work summary for the project are provided in Section 2. Section 3 presents the project team organization, personnel responsibilities, and lines of authority. Training and medical monitoring requirements are contained in Section 4. Section 5 presents a safety and health risk analysis. Section 6 contains the program emergency response plan. Program requirements for levels of protection are included in Section 7, and air monitoring procedures are provided in Section 8. Site control measures, including designation of site work zones, are contained in Section 9, while Section 10 provides decontamination procedures. Section 11 contains information on the use and calibration of air monitoring equipment. Appendix A contains an example of an Emergency Contacts Form to be used in each formal health and safety plan addenda prepared for all U.S. Air Force Bioventing sites. Appendix B contains a Plan Acceptance Form, Site Specific Training Records, Personal Air Sampling Data Form, Accident Report Form, Daily Health and Safety Report Form, Self Contained Breathing Apparatus (SCBA) Log Forms, and Respirator Use Forms.

SECTION 2

PROJECT DESCRIPTION AND SCOPE OF WORK

2.1 PROJECT DESCRIPTION

Work performed under this contract will remediate soils primarily contaminated with fuels using venting and bioremediation technologies. Sites will be located on Air Force installations across the United States and remediation activities will be performed under a variety of climatic, soil, and contaminant conditions.

2.2 SCOPE OF WORK

The objective of the bioventing program is to aid in remediating site soils. This scope of work was developed through evaluation of previous investigation results, current remediation efforts, and results of a bioventing pilot test at other Air Force sites.

The scope of work for this project includes construction and installation of the bioventing system, and operation, monitoring and maintenance of the system for one year. This project will include the following field activities: drilling and installation of vapor collection and monitoring wells; excavation of shallow trenches; assembly and wiring of mechanical/electrical components of venting/biodegradation systems; maintenance of the system; and periodic sampling and monitoring of soil vapors at the site.

SECTION 3

PROGRAM TEAM ORGANIZATION

The Engineering-Science team assigned to the bioventing program, their responsibilities, and lines of authority are outlined below.

<u>Name</u>	<u>Task Assigned</u>
Mr. R. Bionovi	Program Manager
Mr. Doug Downey	Project Manager
Ms. Gail Saxton	Deputy Project Manager
Mr. Timothy Mustard	Program Health and Safety Manager
Major Ross Miller	Contact - AFCEE TPM

The installation managers (to be assigned) are responsible for the overall conduct of the project, including enforcing the requirements of the program health and safety plan. The program health and safety manager will be responsible for updating and revising the program health and safety plan, as necessary. He will arrange for periodic field audits to ensure that the provisions of the health and safety plan are being enforced. These audits will be conducted to verify compliance with the corporate health and safety program and applicable regulations.

The installation manager will supervise construction and installation of the venting/bioremediation system and serve as the site health and safety officer (SHSO). This person is responsible for assuring that the day-to-day bioventing activities are performed in conformance with the project health and safety plan. The SHSO has the authority to stop work on the site if actions or conditions are deemed unsafe or not in conformance with the health and safety plan.

All field team members and subcontractors are responsible for reading and conforming with this health and safety plan. All ES team members will sign the statement found in Appendix B stating they have read the plan, are familiar with its contents and have received training in accordance with OSHA regulation 29 CFR 1910.120(e). No employee will perform a project activity that he or she believes may endanger his or her health and safety or the health and safety of others.

SECTION 4

SITE-SPECIFIC EMPLOYEE TRAINING AND MEDICAL MONITORING REQUIREMENTS

The ES corporate health and safety manual is incorporated by reference (Engineering-Science, Inc., 1987). It presents general requirements for Engineering-Science employee training and medical monitoring. All field team members will have the 40-hour Occupational Safety and Health Administration (OSHA) training as specified in Title 29, Code of Federal Regulations Section 1910.120 (29 CFR 1910.120) and a current 8-hour annual refresher course. All field team members will be on appropriate and current medical monitoring programs. Listed below are additional health and safety training and medical monitoring requirements for this project.

4.1 ADDITIONAL SAFETY TRAINING REQUIREMENTS

All Engineering-Science team personnel engaged in site supervisory positions will have completed the 8-hour OSHA supervisory training as specified in 29 CFR 1910.120(e). All field team members must have site-specific training. Weekly safety briefings will be conducted if necessary.

4.2 ADDITIONAL MEDICAL MONITORING REQUIREMENTS

There are no additional medical monitoring requirements for bioventing sites on U.S. Air Force Bases under this contract.

SECTION 5

SAFETY AND HEALTH RISK ANALYSIS

5.1 CHEMICAL HAZARDS

The chemicals of primary concern occurring at the majority of sites will be those originating from jet fuel. One-third of these sites may be contaminated with trichloroethene (TCE) or other chlorinated solvents. The properties of jet fuel and several of its volatile constituents are summarized in Table 5.1. If additional compounds are discovered at other Air Force Facilities, the health and safety plan shall be amended and pertinent information about the compounds will be provided in site-specific health and safety plan addenda.

5.2 PHYSICAL HAZARDS

5.2.1 Heat Stress

Because work at the Air Force bases may occur during warm months, heat stress could be a concern. Although protective clothing is not anticipated at the majority of sites, monitoring of personnel wearing personal protective clothing will commence when ambient temperature is 70°F or above. Monitoring frequency should increase as the ambient temperature increases or as slow recovery rates are observed. A more detailed explanation of heat stress monitoring is discussed in Section 7.

5.2.2 Other Physical Hazards

Employees must implement safe work practices in accordance with OSHA regulations while working on site. In addition to the hazardous substances and environments present onsite, other physical hazards may exist during installation of bioventing equipment, including risk of injury while working in or around equipment. Work areas should therefore be cordoned off to protect both public and operational personnel. Additional information concerning construction hazards is presented in Section 6.3 - Electrical Safety, Section 6.4 - Fire Safety, Section 6.5 - Physical Hazards, and Section 9.4 - Safe Work Practices.

HEALTH AND PHYSICAL HAZARD AND RECOGNITION QUALITIES OF SITE CONTAMINANTS/

TABLE 3.1

Contaminant	PEL ^{b/} (ppm)	TLV ^{c/} (ppm)	IDLH ^{d/} (ppm)	Warning		Fire Hazard	Explosion Hazard	Comments
				Conc. e/ (ppm)	IP ^{f/} (eV)			
Benzene ^{g/}	1	10	3,000	4.65	9.24	Dangerous	Moderate	Eye and nose irritant. Chronic exposure has been linked to leukemia.
Ethylbenzene ^{g/}	100	100	2,000	0.2-200	0.76	Dangerous	Moderate	Eye and mucous membrane irritant. Can cause headache, narcosis, and coma following exposure to high concentrations.
Gasoline ^{h/}	300	300	--	<.01-10	--	Dangerous	Moderate	Avoid skin and eye contact.
Jet Fuel ^{j/}	500	300	10,000	0.06	--	Dangerous	Moderate	No exposure limits set. Long-term effects include liver, kidney, and CNS damage.
Toluene ^{g/}	100	100	2,000	0.2-4.0	0.0	Dangerous	Moderate	Fatigue, weakness, confusion, and headache.
Trichloroethene (TCE) ^{h/}	50	50	1,000	21.4-100	9.45	Dangerous	Moderate	Suspected carcinogen, narcotic anesthetic, eye irritant, causes nausea, vomiting, visual disturbances arrhythmics
Xylene ^{g/}	100	100	1,000	0.05-200	0.5	Moderate	Moderate	Dizziness, drowsiness, irritant and may cause vomiting and abdominal pains.

a/ Information summarized from Sax, 1979, Dangerous Properties of Industrial Materials, Fifth Edition; OSHA regulations contained in 29 CFR 1910.1000; EPA, 1983, Response Safety Decision-Making Workshop manual; American Conference of Governmental Industrial Hygienists (ACGIH) 1991-92 Threshold Limit Values; and National Institute for Occupational Safety and Health (NIOSH)/OSHA 1990, Pocket Guide to Chemical Hazards.

b/ PEL: Permissible Exposure Limit expressed as parts per million (ppm) unless otherwise indicated. OSHA limit as found in 29 CFR 1910.1000.

c/ TLV: Threshold Limit Value expressed as ppm unless otherwise indicated. From Plunkett, E.R., Handbook of Industrial Toxicology, 1978; or ACGIH 1991-92.

d/ IDLH: Immediately dangerous to life or health. Expressed as ppm unless otherwise indicated.

e/ Warning concentration is the odor threshold of the substance. Different sources listed different warning concentrations. When a range is given, use the highest concentration.

f/ IP - Ionization potential expressed in electron volts (eV).

g/ Volatile components of gasoline and jet fuel.

h/ Potential human carcinogen.

i/ Note: Primary constituent of concern in gasoline is Benzene. The OSHA PEL for Benzene is 1 ppm.

j/ Based on petroleum distillates (naphtha).

SECTION 6

EMERGENCY RESPONSE PLAN

Site activities will present a degree of risk to onsite personnel. During routine operations, risk is minimized by establishing good work practices, staying alert, and using proper personal protective equipment (PPE). Unpredictable events such as physical injury, chemical exposure, or fire may occur and must be anticipated. All field team members must participate in Red Cross or equivalent first aid and cardiopulmonary resuscitation (CPR) courses to more effectively handle physical and medical emergencies that may arise in the field. The sections below establish procedures and guidelines for emergencies.

6.1 GUIDELINES FOR PRE-EMERGENCY PLANNING AND TRAINING

Employees must read this health and safety plan, the site specific addendum to this plan, and familiarize themselves with the information in this chapter. Prior to project initiation, the SHSO will conduct a meeting with the field team members to review the provisions of this health and safety plan and to review the emergency response plan. Employees are required to have a copy of the emergency contacts and telephone numbers immediately accessible onsite and know the route to the nearest emergency medical services. The emergency contacts, telephone numbers, and routes to the hospital will be provided in the site-specific health and safety plan addenda prepared for each bioventing site.

6.2 EMERGENCY RECOGNITION AND PREVENTION

Emergency conditions are considered to exist if:

- Any member of the field crew is involved in an accident or experiences any adverse effects or symptoms of exposure while onsite.
- A condition is discovered that suggests the existence of a situation more hazardous than anticipated.
- Concentrations of combustible vapors reach or exceed 20 percent of the lower explosive limit (LEL).
- A fire or explosion hazard exists.

Some ways of preventing emergency situations are listed below.

- Site workers must maintain visual contact and should remain close together to assist each other during emergencies.

- During continual operations, onsite workers act as safety backup to each other. Offsite personnel provide emergency assistance.
- All field crew members should make use of all of their senses to alert themselves to potentially dangerous situations which they should avoid (e.g., presence of strong and irritating or nauseating odors).
- Field crew members will be familiar with the physical characteristics of investigations, including:
 - Wind direction in relation to contamination zones;
 - Accessibility to associates, equipment, and vehicles;
 - Communications;
 - Hot zone (areas of known or suspected contamination);
 - Site access; and
 - Nearest water sources.
- Personnel and equipment in a work area should be minimized, consistent with effective site operations.

In the event that any member of the field crew experiences any adverse effects or symptoms of exposure while on the scene, or that organic vapors and combustible vapors exceed the action limits, the entire field crew will immediately halt work and act according to the instructions provided by the SHSO.

The discovery of any condition that would suggest the existence of a situation more hazardous than anticipated will result in the evacuation of the field team and reevaluation of the hazard and the level of protection required.

In the event an accident occurs, the field supervisor is to complete an Accident Report Form. Follow-up action should be taken to correct the situation that caused the accident.

Electrical safety, fire safety, physical hazards, general emergency procedures, and specific procedures for handling personal injury and chemical exposure, are described in the following sections.

6.3 ELECTRICAL SAFETY

The equipment used in the bioventing system is electrically operated. Maintenance and day-to-day activities require personnel to handle and control this equipment. Unless safe work practices are strictly observed, serious injury or death can result.

Ordinary 120 volt (V) alternating current may be fatal. Extensive studies have shown that currents as low as 10 to 15 milliamps (mA) can cause loss of muscle control and that 12 V AC may, on good contact, cause injury. Therefore, all voltages should be considered dangerous. All electricity should be treated cautiously by trained personnel.

Electricity kills by paralyzing the nervous system and stopping muscular action. Frequently, electricity may hit the breathing center at the base of the brain and interrupt the transmission of the nervous impulses to the muscles responsible for breathing. In other cases, the electrical current directly affects the heart, causing it to cease pumping blood. Death follows from lack of oxygen in the body. It cannot be determined which action has taken place, therefore, a victim must be freed from the live conductor promptly by use of a dry stick or other nonconductor or by turning off the electricity to at least this point of contact. Never use bare hands to remove a live wire from a victim or a victim from an electrical source. CPR or artificial respiration should be applied immediately and continuously until breathing is restored, or until a doctor or emergency medical technician arrives.

6.3.1 General Electrical Safety Rules

- While working on electrical circuits, do not touch the switch box cabinet or any other object, such as a pipe, that will give electric current a path through your body. Do not stand in water and, if possible, place a rubber mat under your feet.
- Allow only authorized people to work on electrical panels.
- Keep rubber mats in front of electrical panels.
- Treat all electrical wires and circuits as "live," unless you are certain they are not.
- Use approved rubber gloves.
- Electrical control panels should never be opened unless the job requires it.
- No part of the body should be used to test a circuit.
- Always work from a firm base as loss of balance may cause a fall onto energized busses or parts. Energized busses and parts should be covered with a good electrical insulator such as a rubber blanket while exposed.
- No safety device should be made inoperative by removing guards, using oversized fuses, blocking or bypassing protective devices, unless it is absolutely essential to the repair or maintenance activity, and then only after alerting operating personnel and the maintenance supervisor. Follow OSHA lockout/tagout requirements.
- All tools should have insulated handles, be electrically grounded, or double insulated.
- Jewelry should never be worn when working on electric circuits.
- Use fuse pullers to change fuses.
- Never use metal ladders, metal tape measures, or other metal tools around electrical equipment.
- Keep wires from becoming a tripping hazard.

- When performing electrical work, even simply energizing a piece of equipment, observe "No Smoking" signs.
- When working around electrical equipment, keep your mind on the potential hazards at all times.

6.3.2 Holding and Locking Out Electrical Circuits

The most important safety requirement in electrical maintenance is to have and adhere to a good system for locking out electrical circuits when equipment is being repaired. Unexpected operation of electrical equipment that can be started by automatic or manual remote control may cause injuries to persons who happen to be close enough to be struck.

When motors or electrical equipment require repair, the circuit should be opened at the switch box, and the switch should be padlocked in the "OFF" position.

All personnel involved in maintenance work should be instructed in the following lockout procedure:

- Alert the affected personnel.
- Before starting work on an engine, motor line shaft, or other power transmission equipment, or power driven machine, make sure it cannot be set in motion without your permission.
- Place your own padlock on the control switch, lever, or valve, even though someone may have already locked the control. You will not be protected unless you put your own padlock on it.
- When through working at the end of your shift, remove your padlock; never permit someone else to remove it for you; and be sure you are not exposing another person to danger by removing your padlock.
- After repair, clear personnel from area BEFORE closing the breaker.

Further information concerning lockout/tag out procedures can be found in 54 CFR Part 169.

6.4 FIRE SAFETY

Jet fuel and possibly some solvents have been released into the soils at these sites and vapors escaping from the soils may be flammable or explosive (if in a confined space). Therefore, precautions should be taken when doing field work (drilling or system construction/installation) to ensure that combustible or explosive vapors have not accumulated or that an ignition source is not introduced into a flammable atmosphere.

OSHA standards for fire protection and prevention are contained in 29 CFR Subpart F, 1926.150 through 1926.154. Of particular concern on this site are:

- Proper storage of flammables;
- Adequate numbers and types of fire extinguishers;

- Use of intrinsically safe or explosion proof equipment where appropriate; and
- Monitoring for development of an explosive atmosphere.
- Prevention of explosive atmospheres by placing blower equipment in well-ventilated enclosures.

6.5 PHYSICAL HAZARDS

The scope of work for this study involves working outdoors around vehicles and heavy equipment. Any project involving heavy equipment, unimproved work sites, and outside work can present numerous physical hazards to the work force. Training, adherence to work rules, and careful housekeeping can prevent many problems or accidents arising from physical hazards. The general rules and preventative measures for this work follows.

6.5.1 Motor Vehicles and Heavy Equipment

Working with large motor vehicles and heavy equipment could be a major hazard at these sites. Injuries can result from equipment hitting or running over personnel and impacts from flying objects or overturning of vehicles. Vehicles and heavy equipment design and operation will be in accordance with 29 CFR, Subpart O, 1926.600 through 1926.602. In particular, the following precautions will be used to help prevent injuries and accidents:

- Brakes, hydraulic lines, light signals, fire extinguishers, fluid levels, steering, tires, horn, and other safety devices will be checked and recorded on a log sheet at the beginning of each week.
- Do not back up large construction motor vehicles unless the vehicle has a reverse signal alarm audible above the surrounding noise level, backup warning lights, or when an observer signals it is safe to do so.
- Heavy equipment or motor vehicle cabs will be kept free of all nonessential items and all loose items will be secured.
- Construction and heavy equipment will be provided with necessary safety equipment including seat belts, roll over protection, emergency shutoff during roll over, backup warning lights, and audible alarms.
- Blades and buckets will be lowered to the ground and parking brakes will be set before shutting off any heavy equipment or vehicle.

6.5.2 Slip, Trip and Fall Hazards

The sites could contain a number of slip, trip and fall hazards for site workers, such as:

- Holes, pits, or ditches;
- Slippery surfaces;
- Steep grades;
- Uneven grades; and

- Sharp objects.

Site personnel will be instructed to look for potential safety hazards and immediately inform the site health and safety officer or the task manager about any new hazards. If the hazard cannot be immediately removed, actions must be taken to warn site workers about the hazard.

6.5.3 Excavation Activities

Prior to any excavation activity, the location, if any, of underground installations such as sewers, telephone, water, fuel, and electric lines must be determined. The walls and faces of all excavation in which personnel are exposed to danger from moving ground must be guarded by a shoring system, sloping of the ground, or by some other equivalent means.

Excavations (greater than 4 feet deep) must be inspected by a competent person, as defined in OSHA, after every rainstorm or other hazard increasing occurrence, and the protection against slides and wall collapse will be increased if necessary. All OSHA requirements concerning excavation activities, contained in 29 CFR 1926.651, must be followed.

6.5.4 Drilling Accidents

Hazards associated with drilling activities may occur from suspended loads dropping on employees, being caught behind a load and a stationary object, or being struck by counterweights. Accidents of this type are most likely to occur during drilling operations and can be prevented by the safe operation of drilling equipment, wearing protective equipment including a hard hat and safety boots, and the routine inspection of drilling equipment to identify unsafe conditions (e.g., frayed ropes).

6.5.5 Subsurface Hazards

Before any drilling or soil gas activity begins, efforts must be made to determine whether underground installations, (e.g., sewers, telephone, water, fuel, and electric lines) will be encountered and, if so, where such underground installations are located. Utility companies or the base engineer will be contacted by the field team leader prior to commencing drilling or soil gas operations and the necessary clearances obtained using Air Force Form 103.

6.5.6 Electrical Line Clearance and Thunderstorms

Extra precautions will be exercised when drilling near overhead electrical lines. The minimum clearance between overhead electrical lines of 50 kilovolts (kV) or less and the drill rig is 10 feet. For lines rated over 50 kV, the minimum clearance between the lines and any part of the rig is 10 feet plus 0.4 inches for each kV over 50 kV. Drilling operations must cease during thunderstorms.

The SHSO will provide onsite surveillance of the drilling subcontractor to ensure that personnel meet these requirements. If deficiencies are noted, work will be stopped and corrective actions implemented. Reports of health and safety deficiencies and the corrective actions taken will be forwarded to the installation manager by the SHSO.

6.5.7 Noise-Induced Hearing Loss

Work onsite may involve the use of heavy equipment such as a drill rig, compressor, generator, and excavation equipment. The unprotected exposure of site workers to this noise or to aircraft noise during activities near runways or aircraft can result in noise induced hearing loss. The SHSO will ensure that either ear muffs or disposable foam earplugs are made available to, and used by, all personnel in the vicinity of the operation of heavy equipment, aircraft noise or other sources of high intensity noise.

6.6 PERSONNEL ROLES, LINES OF AUTHORITY, AND COMMUNICATION PROCEDURES DURING AN EMERGENCY

When an emergency occurs, decisive action is required. Rapidly made choices may have far reaching, long-term consequences. Delays of minutes can create life threatening situations. Personnel must be ready to respond to emergency situations immediately. All personnel should know their own responsibilities during an emergency, know who is in charge during an emergency, and know the extent of that person's authority. This section outlines personnel roles, lines of authority, and communication procedures during emergencies.

In the event of an emergency situation at a site, the installation manager (SHSO) will assume total control and will be responsible for onsite decision making. The designated alternate for the SHSO will be the test engineer. These individuals have the authority to resolve all disputes about health and safety requirements and precautions. They will also be responsible for coordinating all activities until emergency response teams (ambulance, fire department, etc.) arrive onsite.

The installation manager will ensure that the necessary Air Force personnel, Engineering-Science team personnel, and agencies are contacted as soon as possible after the emergency occurs. All onsite personnel must know the location of the nearest telephone and the location of the emergency telephone number list.

6.7 EVACUATION ROUTES AND PROCEDURES, SAFE DISTANCES, AND PLACES OF REFUGE

In the event of emergency conditions, employees will evacuate the area as instructed, transport injured personnel, or take other measures to mitigate the situation. Evacuation routes and safe distances will be decided upon and posted by the field team prior to initiating work.

6.8 DECONTAMINATION OF PERSONNEL DURING AN EMERGENCY

Procedures for leaving a contaminated area must be planned and implemented prior to going onsite. Work areas and decontamination procedures must be established based on expected site conditions. If a member of the field crew is exposed to chemicals, the emergency procedures outlined below should be followed:

- Another team member (buddy) should assist or remove the individual from the immediate area of contamination to an upwind location if it is safe to do so.

- Precautions should be taken to avoid exposure of other individuals to the chemical.
- If the chemical is on the individual's clothing, the clothing should be removed if it is safe to do so.
- Administer first aid and transport the victim to the nearest medical facility, if necessary.

6.9 EMERGENCY SITE SECURITY AND CONTROL

For this project, the installation manager (or designated representative) must know who is onsite and who is in the work area. Personnel access into the work area should be controlled. In an emergency situation, only necessary rescue and response personnel should be allowed into the exclusion zone.

6.10 PROCEDURES FOR EMERGENCY MEDICAL TREATMENT AND FIRST AID

6.10.1 Chemical Exposure

In the event of chemical exposure (skin contact, inhalation, ingestion) the following procedures should be implemented:

- Another team member (buddy) should assist or remove the individual from the immediate area of contamination to an upwind location if it is safe to do so.
- Precautions should be taken to avoid exposure of other individuals to the chemical.
- If the chemical is on the individual's clothing, the clothing should be removed if it is safe to do so.
- If the chemical has contacted the skin, the skin should be washed with copious amounts of water, preferably under a shower.
- In case of eye contact, an emergency eye wash should be used. Eyes should be washed for at least 15 minutes.
- If necessary, the victim should be transported to the nearest hospital or medical center. If necessary, an ambulance should be called to transport the victim.

6.10.2 Personal Injury

In the event of personal injury:

- Field team members trained in first aid can administer treatment to an injured worker.
- The victim should be transported to the nearest hospital or medical center. If necessary, an ambulance should be called to transport the victim.
- The field supervisor is responsible for the completion of an Accident Report Form.

6.10.3 Fire or Explosion

In the event of fire or explosion, personnel will evacuate the area immediately. Administer necessary first aid to injured employees. Personnel will proceed to a safe area and phone the emergency support services. Upon contacting the emergency support services, state your name, nature of the hazard (fire, high combustible vapor levels), the location of the incident, and whether there were any physical injuries requiring an ambulance. Do not hang up until emergency support services has all of the additional information they may require.

6.10.4 Emergency Contacts

In the event of any situation or unplanned occurrence requiring assistance, the appropriate contact(s) should be made from the list provided in the health and safety plan addenda. For emergency situations, telephone or radio contact should be made with the site point of contact or site emergency personnel who will then contact the appropriate response teams.

SECTION 7

LEVELS OF PROTECTION AND PERSONAL PROTECTIVE EQUIPMENT REQUIRED FOR SITE ACTIVITIES

7.1 PERSONAL PROTECTIVE EQUIPMENT

Levels of protection and PPE required for site activities are based upon the risk of exposure to chemical contaminants (fuel hydrocarbons, TCE, etc.). The personal protection level prescribed for these projects is OSHA Level D with a contingency for the use of OSHA modified Level D as well as Level C or Level B. PPE will be required when handling contaminated samples, working with potentially contaminated materials, during construction or installation of bioventing systems.

The Level D modified personnel protective ensembles will be required when personnel are handling contaminated samples or working with potentially contaminated equipment during construction or installation of the bioventing system. Such Level D modified PPE could typically include:

- Vinyl or latex inner gloves;
- Neoprene or "Silver Shield" outer gloves;
- Leather or rubber safety boots (construction or installation only);
- Hard Hat (construction or installation only); and
- Disposable coveralls (construction or installation only).

The following is required for construction activities involving soil excavation activities and suggested for all site activities:

- Either an OVA, HNu, or Photovac TIP or Micro TIP;
- Full size trash bags for decontamination; and
- Plastic drop cloth for decontamination.

7.2 EQUIPMENT NEEDS

Each field team shall have the following items readily available:

- Copy of site health and safety plan including a separate list of emergency contacts;

- First aid kit;
- Three half-face respirators and 24 clean cartridges
- Eye wash bottle;
- Paper towels;
- Air monitoring instruments
- 55 Gallon drums
- Decontamination supplies;
- Water; and
- Plastic garbage bags.

7.3 HEAT STRESS

Hot weather can cause physical discomfort, loss of efficiency, and personal injury. Heat stress can occur even when temperatures are moderate. The following recommendations will help reduce heat stress:

- Provide plenty of liquids. To replace body fluids (water and electrolytes) lost due to sweating, use a 0.1 percent salt water solution, more heavily salted foods, or commercial mixes. The commercial mixes may be preferable for those employees on a low-sodium diet.
- Provide cooling devices to aid natural body ventilation. These devices, however, add weight, and their use should be balanced against worker efficiency.
- In extremely hot weather, conduct activities in the early morning or evening.
- Ensure that shade is available to protect personnel from heat.

7.3.1 Effects of Heat Stress

If the body's physiological processes fail to maintain a normal body temperature because of excessive heat, a number of physical reactions can occur. They can range from mild symptoms such as fatigue, irritability, anxiety, and decreased concentration, dexterity, or movement to death. Medical help must be obtained for the more serious cases of heat stress.

7.3.2 Heat-Related Problems

- **Heat rash:** Caused by continuous exposure to heat and humid air and aggravated by chafing clothes. Decreases ability to tolerate heat and is a nuisance.
- **Heat cramps:** Caused by profuse perspiration with inadequate fluid intake and chemical replacement, especially salts. Signs include muscle spasm and pain in the extremities and abdomen.

- **Heat exhaustion:** Caused by increased stress on various organs to meet increased demands to cool the body. Signs include shallow breathing; pale, cool, moist skin; profuse sweating; and dizziness and lassitude.
- **Heat stroke:** The most severe form of heat stress. Body must be cooled immediately to prevent severe injury and/or death. Signs include red, hot, dry skin; no perspiration; nausea; dizziness and confusion; strong, rapid pulse; and possibly coma. Medical help must be obtained immediately.

7.3.3 Heat-Stress Monitoring

Monitoring of personnel wearing impervious clothing will begin when the ambient temperature is 70°F or above. Table 7.1 presents the suggested frequency for such monitoring. Monitoring frequency will increase as the ambient temperature increases or as slow recovery rates are observed. Heat-stress monitoring will be performed by a person with a current first-aid certification who is trained to recognize heat-stress symptoms. For monitoring the body's recuperative abilities from excess heat, one or more of the techniques listed below will be used. Other methods for determining heat-stress monitoring, such as the wet bulb globe temperature index from the ACGIH TLV booklet may be used.

To monitor the worker, measure:

- **Heart rate:** Count the radial pulse during a 30-second period as early as possible during the rest period.
 - If the heart rate exceeds 110 beats per minute at the beginning of the rest period, the next work cycle will be shortened by one-third and the rest period will remain the same.
 - If the heart rate still exceeds 110 beats per minute at the next rest period, the following work cycle will be reduced by one third.
- **Oral temperature:** Use a clinical thermometer (3 minutes under the tongue) or similar device to measure the oral temperature at the end of the work period (before drinking).
 - If oral temperature exceeds 99.6°F (37.6°C), the next work cycle will be reduced by one-third without changing the rest period.
 - If oral temperature still exceeds 99.6°F (37.6°C) at the beginning of the next rest period, the following cycle will be reduced by one-third.
 - No worker will be permitted to wear a semipermeable or impermeable garment when oral temperature exceeds 100.6°F (38.1°C).

TABLE 7.1
SUGGESTED FREQUENCY OF PHYSIOLOGICAL MONITORING
FOR FIT AND ACCLIMATIZED WORKERS^{a/}

Adjusted Temperature ^{b/}	Normal Work Ensemble ^{c/}	Impermeable Ensemble
90°F (32.2°C) or above	After each 45 minutes of work	After each 15 minutes of work
87.5°-90°F (30.8°- 32.2°C)	After each 60 minutes of work	After each 60 minutes of work
82.5°-87.5°F (28.1°- 30.8°C)	After each 90 minutes of work	After each 90 minutes of work
77.5°-82.5°F (25.3°- 28.1°C)	After each 120 minutes of work	After each 120 minutes of work
72.5°-77.5°F (22.5°- 25.3°C)	After each 150 minutes of work	After each 120 minutes of work

a/ For work levels of 250 kilocalories/hour.

b/ Calculate the adjusted air temperature (ta adj) by using this equation: $ta\ adj\ ^\circ F = ta\ ^\circ F + (13 \times \% \text{ sunshine})$. Measure air temperature (ta) with a standard mercury-in-glass thermometer, with the bulb shielded from radiant heat. Estimate percent sunshine by judging what percent time the sun is not covered by clouds that are thick enough to produce a shadow. (100 percent sunshine = no cloud cover and a sharp, distinct shadow; 0 percent sunshine = no shadows.)

c/ A normal work ensemble consists of cotton coveralls or other cotton clothing with long sleeves and pants.

SECTION 8

FREQUENCY AND TYPES OF AIR MONITORING

Air monitoring will be used to identify and quantify airborne levels of hazardous substances. Periodic monitoring is required during on site activities. The types of monitoring and equipment to be used are as follows:

<u>Type of Equipment</u>	<u>Minimum Calibration Frequency</u>	<u>Parameter(s) to be Measured</u>	<u>Minimum Sampling Frequency</u>	<u>Sampling Locations</u>
PID-	1/day	Organic Vapors	<ul style="list-style-type: none"> ■ 4/hr or each 5-foot intervals (while disturbing or drilling into soils) ■ 1/hour when working near soil vapor extraction unit 	■ Breathing Zone
Sensidyne® or Draeger® Tubes	-	Benzene	■ When PID exceeds 1 ppm	■ Breathing Zone

During operations that disturb site soils, a photoionization detector (such as an HNu®, Photovac TIP®, or MicroTIP®) should be used to measure ambient air concentrations in the worker breathing zone and to screen split spoon samples which will be taken at five-foot intervals. A concentration of 1 ppm above background in the breathing zone will necessitate evacuation until the area is well ventilated (based on the exposure limit for benzene).

If and when the PID or Microtip® exceeds 1 ppm for a one minute period, site workers will move upwind and don respirators. The SHSO will then reenter the "hot" zone with a benzene sensitive Sensidyne® tube and PID. If the benzene concentration is less than 1 ppm and the PID is less than 100 ppm the work site can be reentered without a respirator (Note: by locating yourselves upwind of drilling operations much of this procedure can be avoided). If benzene concentrations are

greater than 1 ppm and a safe upwind location cannot be identified, half-face respirators will be used. If benzene concentrations exceed 10 ppm and a safe upwind location cannot be identified, work will cease.

Bioventing tests will not be performed on sites requiring Level B respiratory protection. The SHSO will determine whether it is safe to continue activities or assign an upgrade to Level C protection.

For other activities at the site (such as taking readings at system), use the PID's to monitor worker exposure levels. Worker exposure monitoring will be conducted to document any exposures to organic vapors received onsite.

The results of air monitoring will be noted in the logbook and the air monitoring data form. The employees for which the breathing zone monitoring was performed will be listed. Copies of the logbook entries will be placed in the employee medical files for exposure documentation.

Calibration, use, and maintenance information for the air sampling equipment to be used onsite are contained in Section 11.

SECTION 9

SITE CONTROL MEASURES

The following site control measures will be followed in order to minimize potential contamination of workers, protect the public from potential site hazards, and to control access to the sites. Site control involves the physical arrangement and control of the operation zones and the methods for removing contaminants from workers and equipment. The first aspect, site organization, is discussed in this section. The second aspect, decontamination, is considered in the next section.

9.1 SITE ORGANIZATION/OPERATION ZONES

Any time respirators are worn, the following operation zones will be established on the site or around a particular site feature (such as the drill rig, or bioventing system).

- Exclusion Zone (Contamination Zone),
- Contamination Reduction Zone, and
- Support Zone.

If protective clothing, such as gloves and/or Tyvek® suits are worn but respirators are not worn (Level D-modified), the field crew will establish a decontamination area to avoid spreading contaminants offsite. The field team leader and/or SHSO will be responsible for establishing the size and distance between zones at the site or around the site feature. Considerable judgement is required to assure safe working distances for each zone are balanced against practical work considerations.

9.1.1 Exclusion Zone (EZ) (Contamination Zone)

The EZ includes the areas where active investigation or cleanup operations take place. Within the EZ, prescribed levels of PPE must be worn by all personnel. The hotline, or EZ boundary, is initially established based upon the presence of actual wastes or apparent spilled material, or through air monitoring, and is placed around all physical indicators of hazardous substances. The hotline may be readjusted based upon subsequent observations and measurements. This boundary should be physically secured and posted or well-defined by physical and geographic boundaries.

Under some circumstances, the EZ may be subdivided into zones based upon environmental measurements or expected onsite work conditions.

9.1.2 Contamination Reduction Zone (CRZ)

Between the EZ and the support zone is the CRZ. This zone provides an area to prevent or reduce the transfer of hazardous materials which may have been picked up by personnel or equipment leaving the exclusion area. All decontamination activities occur in this area. The organization of the CRZ, and the control or decontamination operations, are described in Section 10.

9.1.3 Support Zone

The support zone is the outermost area of the site and is considered a noncontaminated or clean area. The support zone contains the command post for field operations, first aid stations, and other investigation and cleanup support. Normal work clothes are appropriate apparel within this zone; potentially contaminated personnel clothing, equipment, etc., are not permitted.

9.2 SITE SECURITY

Site security is necessary to prevent exposure of unauthorized, unprotected individuals in the work area. The areas immediately surrounding the work area will be clearly marked through use of warning signs, traffic cones, barrier tape, rope, or other suitable means.

Site security will be enforced by the SHSO who will ensure that only authorized personnel are allowed in the work area and that entry personnel have the required level of PPE, are trained under the requirements of 29 CFR 1910.120, and are on a current medical monitoring program.

9.3 SITE COMMUNICATION

Internal site communication is necessary to alert field team members in the EZ and CRZ of emergency conditions, to convey safety information, and to communicate changes or clarification in the work to be performed. For internal site communication, the field team members will use prearranged hand signals (and responses). Radios and/or compressed air horns may also be used for communication.

External site communication is necessary to coordinate emergency response teams and to maintain contact with essential offsite personnel. A telephone will be available for use in external site communication. A list of emergency contact phone numbers is provided in Section 10.2 of the Addendum.

9.4 SAFE WORK PRACTICES

To ensure a strong safety awareness program during field operations, personnel will have adequate training, this health and safety plan must be communicated to the employees, and standing work orders developed and communicated to the employees. Sample standing orders for personnel entering the CRZ and EZ are as follows:

- No smoking, eating, drinking;
- No matches/lighters in the zone;
- Check in/check out at access control points;
- Use the buddy system;
- Wear appropriate PPE;
- Avoid walking through puddles or stained soil;
- Discovery of unusual or unexpected conditions will result in immediate evaluation and reassessment of site conditions and health and safety practices;
- Conduct safety briefings prior to onsite work;
- Conduct daily/weekly safety meetings as necessary; and
- Take precautions to reduce injuries from heavy equipment and other tools.

The following guideleines will also be followed while working onsite:

- Heavy Equipment - Only qualified operators will be allowed to operate heavy equipment. Subcontractors will be required to use the safe work guidelines included in the OSHA General Industry (29 CFR 1910) and Construction Industry (29 CFR 1926) Standards.
- Electrical Equipment - As outlined in Section 6.3.1
- Machine Guarding - All machinery onsite will be properly guarded to prevent contact with rotating shafts, blades or gears.
- Illumination - Work areas will be lighted beyond the minimum requirements of 29 CFR 1910.120
- Engineering Controls - In the event that the project requires additional provisions to safeguard the public and onsite personnel.

SECTION 10

DECONTAMINATION PROCEDURES

10.1 PERSONNEL DECONTAMINATION PROCEDURES

An EZ, CRZ, and support zone will be established whenever field personnel are using Level C respiratory protection. Decontamination station layout will be made on a site-specific basis and will be designed to accommodate the particular PPE worn by employees and the types of chemical hazards encountered. Defined site access and egress points will be established and personnel will enter and exit only through these points.

If personnel are in Level D-modified protection (no respirator but using protective gloves and/or suits and other equipment), a portable decontamination station will be set up at the site. The decontamination station will include provisions for collecting disposable PPE (e.g., garbage bags); washing boots, gloves, vinyl rain suits (if used), and field instruments and tools; and washing hands, face, and other exposed body parts. Onsite personnel will shower upon return to their hotel or homes at the end of the work day. Refuse from decontamination will be bagged and left onsite for proper disposal.

Decontamination equipment will include:

- Plastic buckets and pails;
- Scrub brushes and long-handle brushes;
- Detergent;
- Containers of water;
- Paper towels;
- Plastic garbage bags;
- Plastic or steel 55-gallon barrels;
- Distilled water; and
- An eye wash station.

10.2 DECONTAMINATION OF EQUIPMENT

Decontamination of drilling rigs will be conducted at a location onsite where the rinse water can be collected. High-pressure steam cleaning of drilling rigs will be

necessary prior to the start of the drilling operation, between borehole locations, and before the drill rig leaves the project site. All sampling equipment will be decontaminated prior to use, between samples, and between sampling locations. Sampling equipment should be thoroughly washed with detergent, followed by clean water rinse, solvent (methanol) rinse, and a distilled water rinse. Adequate time will be allowed for solvent evaporation.

SECTION 11

AIR MONITORING EQUIPMENT USE AND CALIBRATION PROCEDURES

11.1 PHOTOVAC TIP® AIR ANALYZER

To use the Photovac TIP® press the power switch, unlock ZERO and SPAN controls by turning locking rings clockwise. Set span control to 5, lock span control by turning locking ring counter-clockwise. Allow TIP® to sample clean air. Adjust zero control until display reads 0.00. Lock zero control by turning locking ring counterclockwise observe sample concentration changes. Turn TIP® off.

The TIP® is used as a direct-reading instrument in conjunction with the span gas kit. In order to calibrate your TIP® press the power switch, unlock the zero and span controls by turning locking rings clockwise. Set span control to 5. Allow TIP® to sample clean air. Adjust zero control until display reads 0.00. Connect bag of span gas to the TIP® inlet. Adjust span control until display indicates the span gas concentration (usually 100 ppm). Disconnect span gas bag. Sample clean air again and readjust zero control until displays reads 0.00. Lock zero control in. Sample span gas again, and readjust span control until display indicates the span gas concentration. Lock span control in. Observe sample concentrations. The concentration of total ionizables is displayed in span gas equivalent units. Turn TIP® off.

11.2 HNu® PHOTOIONIZATION DETECTOR

To use the HNu® connect the probe to the instrument by matching the alignment slot in the probe connector to the key in the 12-pin connector on the control panel, twist the probe connector until a distinct snap and lock is felt. Turn the function switch to battery check position. The needle should read within or above the green battery arc on the scale plate. If the needle is in the lower position of the battery arc, the instrument should be recharged before use. If the red light comes on, the battery should be recharged. Next, turn the functions switch to the on position, and the instrument is ready to take direct air readings.

11.3 TRACETECHTOR® TOTAL VOLATILES ANALYZER

The Tracetechtor® is used for measuring total volatile hydrocarbon gas levels. The ON/OFF switch is located on the front of the case. Once the unit is turned on,

wait a few seconds for the readings to stabilize. Check the battery charge and the alarms before using the instrument.

To calibrate the instrument with span gas, attach the flow regulator to the calibration gas cylinder. Fill a 3-liter Tedlar bag with calibration gas. Connect the instrument to the Tedlar bag using Tygon tubing and wait for the readings to stabilize. Using a small jeweler's screwdriver, adjust the span gas pot on the side of the instrument to obtain a steady reading which corresponds with the calibration gas concentration. Remove the calibration lines and let the instrument run for a full minute to flush out any excess span gas. Check readings; the combustible sensor should now be reading zero in fresh air.

11.4 SENSIDYNE® OR DRAEGER® COLORIMETRIC GAS ANALYSIS TUBES (BENZENE SPECIFIC)

Dräger® tubes can be used to give an instantaneous reading of various organic compounds. Their aim is to determine very small concentrations of a compound in the shortest amount of time. To sample with a Dräger tube use the Dräger® or Sensidyne® bellows pump and select the appropriate tube (for example, a tube marked benzene to look for benzene). Break off both ends on the pump's break-off plate. Insert the tube into the pump head (the tube should be inserted with the arrow pointing towards the pump). There is a given number of suction strokes for each tube/compound. Each box of tubes will have instructions for how many suction strokes are required for that compound.

APPENDIX A
EMERGENCY CONTACTS

APPENDIX A
EMERGENCY CONTACTS

In the event of any situation or unplanned occurrence requiring assistance, the appropriate contact(s) should be made from a list similar to this which will be prepared in the health and safety plan addenda. For emergency situations, telephone or radio contact should be made with the site point of contact or site emergency personnel who will then contact the appropriate response teams.

<u>Contingency Contacts</u>	<u>Phone Number</u>
Nearest phone located at the work site	_____
Base Fire Department	_____
Site Contact	_____
Site Medical Services	_____
Site Emergency Number	_____
Security Police	_____
<u>Medical Emergency</u>	
Hospital Name	_____
Hospital Phone Number	_____
Ambulance Service (Also Police)	_____
Airlift helicopter	_____
Directions or Map to the Hospital	

ES Contacts

ES Project Manager	(303) 831-8100 (w)
Doug Downey	(303) 670-0512 (h)
ES Health and Safety Manager	(303) 831-8100 (w)
Timothy Mustard	(303) 450-9778 (h)
Corporate Health and Safety Manager	(404) 325-0770 (w)
Edward Grunwald	

APPENDIX B
PROJECT HEALTH
AND SAFETY FORMS

APPENDIX B

SITE/BASE SPECIFIC TRAINING RECORD

On this date _____ the following individuals were provided site specific training in accordance with OSHA regulations contained in 29 CFR 1910.120 (e). This individuals have also read and are familiar with the contents of the site specific health and safety plan.

Name (print)	Employee No.	Signature
1.	_____	_____
2.	_____	_____
3.	_____	_____
4.	_____	_____
5.	_____	_____

PLAN ACCEPTANCE FORM
PROJECT HEALTH AND SAFETY PLAN

Instructions: This form is to be completed by each person to work on the subject project work site and returned to the safety manager.

I have read and agree to abide by the contents of the Health and Safety Plan for the following project:

Signed

Date

RETURN TO:

Office Health and
Safety Representative
Engineering-Science, Inc.
1700 Broadway, Suite 900
Denver, CO 80290

DAILY HEALTH AND SAFETY REPORT

This form is to be completed by the ES site Health and Safety Officer or Resident Construction Manager. The aforementioned shall return the original form to the office Health and Safety Representative and place a copy in the site Health and Safety file.

Name _____ Project Name _____
 Date _____ Project Number _____

- 1) Have all field team members reviewed the site H&S Plan? Yes ___ No ___
 If not, explain why and corrective actions taken: _____

- 2) Are Plan Acceptance Forms on file for all field team members?
 Yes ___ No ___
 (If not, obtain form and forward to Office H&S Representative.)
- 3) Is at least one copy of the site H&S Plan present on-site for employee review?
 Yes ___ No ___
 (If not, obtain copy immediately and inform employees of its location.)
- 4) Are all field team members on current and appropriate medical monitoring and have they had the required 40-hour/8-hour training within the past year?
 Yes ___ No ___
 If not, explain why and corrective actions taken: _____

- 5) Have all field team members received on-site H&S training? Yes ___ No ___
 If yes, describe frequency: Initial ___ Daily ___ Weekly ___
 (If not, perform required training before allowing employee(s) to continue working on-site).
- 6) Provide the following information:

<u>Task</u>	<u>Employee Name</u> (by Task)	<u>Level of</u> <u>Respiratory Protection</u> (for each employee)	<u>Comments</u>
-------------	-----------------------------------	---	-----------------

- 7) Was heat stress monitoring performed today? Yes ___ No ___
If yes, was it documented? _____
If no, explain: _____
- 8) Was personal air monitoring conducted today? Yes ___ No ___
If yes, describe: _____
If no, explain : _____
- 9) Describe other air monitoring procedures used today: _____

- 10) Were site work zones established today? Yes ___ No ___
If not, explain: _____

- 11) Describe personal decontamination procedures used today: _____

- 12) Did any accidents occur today? Yes ___ No ___
If yes, describe: _____

- 13) Comments: _____

Return this report to the office Health and Safety Representative.

ACCIDENT REPORT FORM

Project: _____

EMPLOYER

- 1. Name _____
- 2. Mail Address _____
(No. and Street) (City or Town) (State)
- 3. Location, if different from mail address _____

INJURED OR ILL EMPLOYEE

- 4. Name _____ Social Security Number _____
(First) (Middle) (Last)
- 5. Home address _____
(No. and Street) (City or Town) (State)
- 6. Age _____ 7. Sex: Male _____ Female _____ (Check one)
- 8. Occupation _____
(Specific job title, not the specific activity he was performing at time of injury)
- 9. Department _____
(Enter name of department in which injured persons is employed, even though he may have been temporarily working in another department at the time of injury)

THE ACCIDENT OR EXPOSURE TO OCCUPATIONAL ILLNESS

- 10. Place of accident or exposure _____
(No. and Street) (City or Town) (State)

ACCIDENT REPORT FORM
(Continued)

11. Was place of accident or exposure on employer's premises?
(Yes/No)
12. What was the employee doing when injured? _____
(Be specific - If he was
_____ using tools or equipment or handling material, name and tell what he was
_____ doing.)
13. How did the accident occur? _____
(Describe fully the events which resulted
_____ in the injury or occupational illness. Tell what happened and how. Name
_____ any objects or substances involved. Give details on all factors which led
_____ to accident. Use separate sheet for additional space.)
14. Time of accident: _____
15. WITNESSES TO _____
(Name) (Affiliation) (Phone No.)
- ACCIDENT _____
(Name) (Affiliation) (Phone No.)
- _____ (Name) (Affiliation) (Phone No.)

OCCUPATIONAL INJURY OR OCCUPATIONAL ILLNESS

16. Describe the injury or illness in detail and indicate the part of body
affected. _____

17. Name the object or substance which directly injured the employee. (For
example, the machine or thing or struck against or which struck him; the vapor
or poison he inhaled or swallowed; the chemical or radiation which irritated his
skin; or in cases of strains, hernias, etc., the thing he was lifting, pulling, etc.)

ACCIDENT REPORT FORM
(Continued)

18. Date of injury or initial diagnosis of occupational illness _____
(Date)

19. Did employee die? _____ (Yes or No)

OTHER

20. Name and address of physician _____

21. If hospitalized, name and address of hospital _____

Date of report _____ Prepared by _____

Official position _____

**ADDENDUM TO THE PROGRAM HEALTH AND SAFETY PLAN
FOR THE BIOVENTING TEST INITIATIVE**

**ADDENDUM TO THE PROGRAM HEALTH AND SAFETY PLAN
FOR THE BIOVENTING TEST INITIATIVE**

BASE NAME: AF PLANT 6, GA

JOB #DE268.45.02

Installation Manager:

Ola Awosika

Site Health and Safety Officer:

Ola Awosika

Site Contact - U.S. Air Force Installation:

Richard Rextrode

**Ms. Rita Chan
Wright Patterson AFB
(513) 255-4151**

**Air Force Plant 6
(404) 494-2417**

REVIEWED AND APPROVED BY:

Project Manager:

Doug Dancy 10/4/93
Name Date

Program H&S Manager:

Janethy S. Mustard 10/4/93
Name Date

1.0 INTRODUCTION

This addendum modifies the existing Program Health and Safety Plan for the Bioventing Test Initiative, for conducting bioventing pilot tests at United States Air Force facilities under contract number F33615-90-D-4014.

This addendum outlines the site-specific requirements and provides site-specific information for work which will be conducted at AF Plant 6, Georgia. The Site of interest for this bioventing Pilot Study is Jet Fuel (JP-5) Leak Area.

Two additional documents providing information regarding activities to be performed on this site are the Protocol Document and the Site-specific Bioventing Test Work Plan for Air Force Plant 6.

Included or referenced in this addendum are site-specific descriptions, history and site-specific activities; hazard evaluation of known or suspected chemicals; personal protective equipment (PPE); personnel decontamination procedures; site-specific training and medical monitoring requirements; air monitoring; site control procedures; employee exposure monitoring; and emergency response procedures.

2.0 SITE DESCRIPTION, HISTORY, AND SITE-SPECIFIC ACTIVITIES

The site description, history, and site-specific activities to be performed at this site are outlined in the site-specific work plan entitled *Bioventing Test Work Plan for the JP-5 Leak Area, Air Force Plant 6, Marietta, Georgia*.

3.0 SITE-SPECIFIC EMPLOYEE TRAINING AND MEDICAL MONITORING REQUIREMENTS

See Section 4 of the program health and safety plan for guidance.

4.0 HAZARD EVALUATION

4.1 Chemical Hazards

General hazards are addressed in the program health and safety plan. Site-specific hazards are identified below.

Chemicals known or suspected to occur at this site include hydrocarbon fuel components benzene, toluene, ethylbenzene, and xylenes (BTEX), total petroleum hydrocarbons and total lead.

Health hazard qualities for these compounds are presented in Table 5.1 of the program health and safety plan.

4.2 Physical Hazards

Potential physical hazards at this site include risks associated with the installation/operation of bioventing equipment and the hazards from working in or around moving equipment (such as drill rigs, motor vehicles, etc.).

Protection standards for physical hazards are contained in Section 7 of the program health and safety plan.

5.0 AIR MONITORING

During operations that disturb site soils, a hydrocarbon detector (HNU® or equivalent) will be used to measure ambient air concentrations in the worker breathing zone. Flammable vapor monitoring will be conducted if potentially flammable atmospheres occur. See Sections 8 and 11 of the program health and safety plan for specific guidance.

6.0 SITE CONTROL PROCEDURES

Site control measures will be followed in order to minimize potential contamination of workers, protect the public from potential site hazards, and control access to the sites. Site control involves the physical arrangement and control of the operation zones and the methods for removing contaminants from workers and equipment. See Section 9 of the program health and safety plan for guidance.

Specific site control procedures at this site will include those outlined in the program health and safety plan.

7.0 PERSONAL PROTECTIVE EQUIPMENT

It is anticipated that Level D respiratory protection with a contingency for the use of Level C&B will be used at this site. Additional guidelines for the selection of respiratory protection at this site are contingent upon the discovery of benzene while performing site activities. Site crews will assess the need for respiratory protection or PPE as applicable.

Protective clothing to be used at this site includes:

Hard hats

Suits (Tyvek or Saranex)

Inner gloves (Latex or Vinyl)

Outer gloves (Nitrile or Neoprene)

Boots (Safety boots with latex boot covers)

Respirator not anticipated

Cartridges

Other

8.0 PERSONNEL DECONTAMINATION PROCEDURES

See Section 10 of the program health and safety plan for guidance.

9.0 EMPLOYEE EXPOSURE MONITORING

Employee exposure monitoring will be conducted on this site in accordance with federal OSHA Standards (29 CFR 1910) and the program health and safety plan.

10.0 EMERGENCY RESPONSE PLAN

10.1 Safe Distances and Places of Refuge

Prior to initiation of field activities, the field crew shall decide on safe distances to retreat to and a place of refuge in the event of an emergency. This information shall be provided in weekly site-specific safety briefings. All other guidelines established in the program health and safety plan for emergency planning, training, recognition, etc. shall be followed.

10.2 Emergency Information

Hospital Windy Hill Hospital

Address 2540 Windy Hill Road
 Marietta, GA 30061

Phone (404) 951-3371

Description of the route to the hospital.

A Map outlining the best route to the hospital is shown in Figure 10.1.

Other Emergency Numbers:

Fire Department 421-4808
Security Police 421-4909
Ambulance 422-1446

Program Health and Safety Manager:

Tim Mustard work: (303) 831-8100
 home: (303) 450-9778

Project Manager:

Doug Downey work: (303) 831-8100
 home: (303) 670-0512

Figure 10.1

HOSPITAL ROUTE MAP AIR FORCE PLANT 6 MARIETTA, GEORGIA

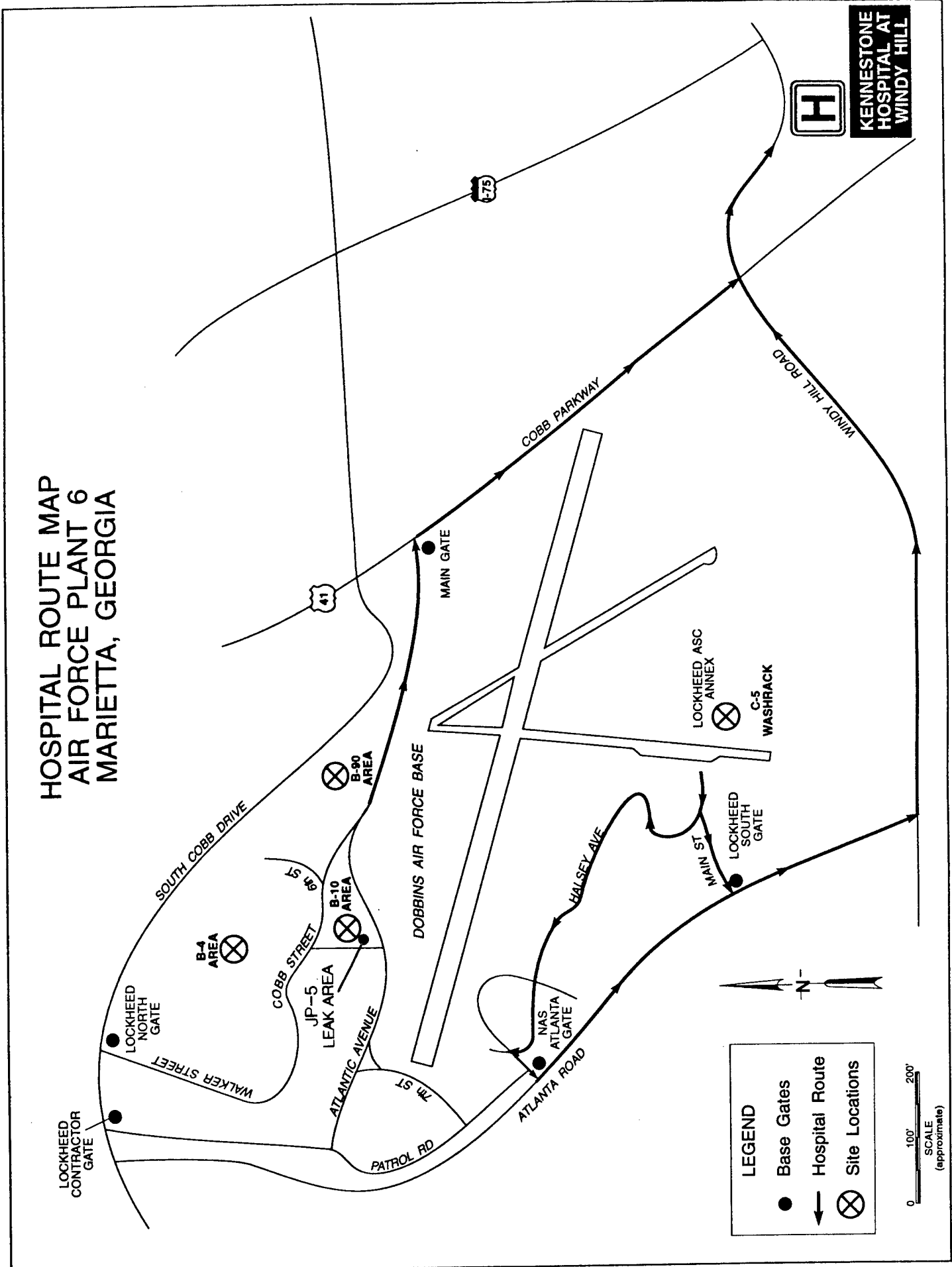

**KENNESTONE
HOSPITAL AT
WINDY HILL**

LEGEND

- Base Gates
- Hospital Route
- ⊗ Site Locations

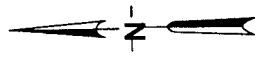
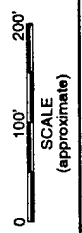

APPENDIX B
QUALITY ASSURANCE PROJECT PLAN

TABLE OF CONTENTS

	<u>Page</u>
B.1 Project Description And Quality Assurance Objectives	B-1
B.1.1 Introduction	B-1
B.1.2 Project Description.....	B-1
B.1.3 Quality Assurance Objectives.....	B-1
B.2 Organization and Staffing	B-2
B.3 Laboratory Testing Quality Assurance Objectives for Data Measurement.....	B-2
B.3.1 Precision.....	B-2
B.3.2 Accuracy.....	B-2
B.3.3 Completeness	B-4
B.3.4 Representativeness.....	B-4
B.3.5 Comparability.....	B-4
B.4 Sample Handling, Sample Receipt.....	B-5
B.4.1 Sample Handling, Packaging, and Shipment	B-5
B.4.1.1 Sample Containers.....	B-5
B.4.1.2 Sample Sealing and Labeling.....	B-5
B.4.1.3 Sample Numbering System.....	B-5
B.4.1.4 Preservatives and Holding Times.....	B-5
B.4.2 Shipping Requirements	B-5
B.4.3 Shipping Addresses	B-9
B.4.3.1 Soil Samples.....	B-9
B.4.3.2 Soil Gas Samples.....	B-9
B.4.4 Sample Receipt.....	B-9
B.5 Sample Custody	B-9
B.5.1 Sample Custody.....	B-12
B.5.2 Transfer of Custody and Shipment	B-12
B.5.3 Laboratory Custody Procedures.....	B-13
B.6 Calibration Procedures and Frequency	B-13
B.7 Analytical Procedures	B-13
B.7.1 Analyses for Organic Compounds and Physical Parameters	B-14
B.7.2 Detection Limits	B-14
B.8 Data Reduction, Validation and Reporting.....	B-14
B.8.1 Field Measurement Data	B-14
B.8.2 Data Analysis and Reporting.....	B-15
B.8.3 Maintenance of Project Documents	B-15
B.9 Field and Laboratory Control Checks.....	B-15
B.9.1 Field Quality Control Samples	B-15
B.9.1.3 Field Duplicates	B-15
B.9.2 Laboratory QA/QC Samples.....	B-15
B.9.2.1 Analytical Duplicate Analyses	B-15
B.9.2.2 Matrix Spike/duplicate Spike Analyses	B-16
B.10 Preventive Maintenance	B-16
B.11 Corrective Action	B-16
B.12 Quality Assurance Audits.....	B-17

LIST OF TABLES

<u>No.</u>	<u>Title</u>	<u>Page</u>
B.1	Sample Analysis Type, Number, Container, Method, Preservative, Holding Time, Reporting Units and Limits, and QA Objectives	B-3
B.2	Sample Numbering System	B-7
B.3	ES Base Number, Name, Abbreviation, and Number of Sites in ES Base Number Order	B-8

LIST OF FIGURES

<u>No.</u>	<u>Title</u>	<u>Page</u>
B.1	Sample Custody Seal and Sample Label.....	B-6
B.2	Chain-of-Custody Record - Soil Matrix	B-10
B.3	Chain-of-Custody Record - Air Matrix	B-11

B.1 PROJECT DESCRIPTION AND QUALITY ASSURANCE OBJECTIVES

B.1.1 INTRODUCTION

This Quality Assurance Project Plan (QAPP) is prepared for the AFCEE Bioventing Pilot Tests at 38 Air Force Bases nationwide. The QAPP follows the procedures as outlined in the standardized ES Quality Assurance Policy Manual. The primary references for this QAPP are the *Test Plan and Technical Protocol for a Field Treatability Test* (Protocol Document) for bioventing and the *Handbook to Support the Installation Restoration Program (IRP) Statements of Work, Volume I, Remedial Investigation/Feasibility Studies (RI/FS)*. Because the purpose of these tests is to determine the feasibility of using the bioventing method for different site conditions, and not for RI/FS work, this QAPP uses the IRP Handbook for guidance but does not rigorously follow its formats and requirements.

The purpose of the quality assurance program is to ensure that the quality standards required to meet the project objectives are followed. The objective of the QAPP is to describe the procedures necessary to demonstrate that field testing, sample acquisition and analysis, review, verification, documentation, and reporting are performed to the quality standards outlined.

B.1.2 PROJECT DESCRIPTION

See Project Description of the Project Management Plan AFCEE Bioventing Pilot Tests (PMP), Section 1.

B.1.3 QUALITY ASSURANCE OBJECTIVES

The primary objective of the Quality Assurance/Quality Control (QA/QC) program is to ensure that the procedures followed and data obtained during the course of the project are adequate to determine the feasibility of using the bioventing methods for soil remediation under a variety of conditions. Specific objectives of the QA/QC program include the following:

- To ensure the use of proper investigative procedures and equipment in the field and the analytical laboratory;
- To specify the responsibilities of personnel included in the QA/QC program and how the program will be implemented; and
- To maintain a high level of quality during the field testing, data analysis, and report writing phases of the project.

B.2 ORGANIZATION AND STAFFING

The Organization and Staff responsibilities, including QA/QC responsibilities, are described in the PMP, Section 3.

B.3 LABORATORY TESTING QUALITY ASSURANCE OBJECTIVES FOR DATA MEASUREMENT

The quality assurance objectives for all laboratory analyses include considerations of precision, accuracy, completeness, representativeness, and comparability.

B.3.1 PRECISION

The precision of a measurement is an expression of mutual agreement of multiple measurement values of the same property conducted under prescribed similar conditions. Precision is evaluated most directly by recording and comparing multiple measurements of the same parameter on the same exact sample under the same conditions.

For laboratory analyses precision is expressed in terms of Relative Percent Difference (RPD). The RPD is calculated as follows:

$$RPD = \frac{(x_1 - x_2) 100}{(x_1 + x_2)/2}$$

where:

x_1 = analyte concentration of first duplicate; and

x_2 = analyte concentration of second duplicate.

Acceptable levels of precision will vary according to the sample matrix, the specific analytical method, and the analytical concentration relative to the method detection limit. Replicate standards and/or spiked samples will be used to estimate the precision of 5 percent (1 in 20) of the analytical test procedures for a known matrix. Table B.1 shows the precision required for each analysis.

B.3.2 ACCURACY

The term accuracy refers to the correctness of the value obtained from analysis of a sample, and is determined by analyzing a sample and its corresponding matrix spike sample. Accuracy is expressed as Percentage Recovery (PR) and is calculated using the following formula:

$$PR = \frac{(A-B)}{C} \times 100$$

TABLE B.1
Sample Analysis Type, Number, Container, Method, Preservative, Holding Time, Reporting Units and Limits, and QA Objectives

SAMPLE MEDIUM	LABORATORY ANALYSIS TYPE Parameter	APPROXIMATE NUMBER SOIL SAMPLES BY SITE		SAMPLE CONTAINER		Analytical Method	Preservative	Holding Time	Holding Time After Leaching	Reporting Units	Method Reporting Limits	Precision of (%)	Accuracy of (%)	Completeness of (%)		
		INITIAL	FINAL	NUMBER	SIZE										TYPE	
SOIL	BERKELEY INORGANIC pH Alkalinity	3	0	1	4 OUNCE	GLASS	None	None	ASAP / 14 Days	pH units mg/kg of as CaCO ₃	0.05 50 mg/kg	20	75	90		
									None	6 Months NA //	5.4 mg/kg 0.1%	20	75	90		
									Hold at 4 C	14 Days 14 Days 14 Days 14 Days	mg/kg // mg/kg mg/kg mg/kg	0.6 mg/kg 0.7 mg/kg 0.5 mg/kg 0.9 mg/kg	20	75	90	
										14 Days 14 Days	mg/kg	10 mg/kg	20	75	90	
		ORGANIC Benzene Toluene Ethyl Benzene Xylenes (total) TRPNI ^a	3	3	1	4 OUNCE	3" DIA. SHELBY	None	None	None	None	None	20	75	90	
		SEQUOIA ANALYTICAL INORGANIC Total Kjeldahl Nitrogen Total Phosphate	3	0	1	16 OUNCE	GLASS	None	None	28 Days 28 Days	mg/kg mg/kg	1.0 mg/kg 1.0 mg/kg	20	75	90	
		PHYSICAL Soil Classification							NA	NA	U.S. Standard Units	NA	20	75	90	
	AIR	AIR TOXICS ORGANIC Benzene Toluene Ethyl Benzene Xylenes (total) TVN ^b	3	3	1	1 LITER	SUNMA ^c CANNISTER	None Do Not Chill	None	None	None	ppmv, µg/L // ppmv, µg/L ppmv, µg/L ppmv, µg/L	0.001, 0.003 0.001, 0.004 0.001, 0.004 0.001, 0.004	20	75	90
														20	75	90
														20	75	90
													20	75	90	

NOTE:

- a/ // Precision - Expressed as relative percent difference (RPD) of analytical results unless otherwise noted.
- b/ Accuracy - Expressed as percentage recovery (PR).
- c/ Completeness - Valid data percentage of total test results.
- d/ ASAP - As soon as possible.
- e/ NA - Not applicable.
- f/ mg/kg - milligrams per kilogram.
- g/ µg/kg - micrograms per kilogram.
- h/ TRPNI - total recoverable petroleum hydrocarbons.
- i/ ppmv - parts per million per volume, µg/L - micrograms per liter.
- j/ TVN - total volatile hydrocarbons.

where:

- A = spiked sample result (SSR);
- B = sample result (SR); and
- C = spike added (SA).

The degree of accuracy and the recovery of analyte to be expected for the analysis of QA samples and spiked samples is dependent upon the matrix, method of analysis, and compound or element being determined. The concentration of the analyte relative to the detection limit is also a major factor in determining the accuracy of the measurement. The practical quantitation level for most analyses is generally stated in the analytical method. Certified standards and/or spiked samples will be used to estimate analyte recovery for each test procedure for a known matrix. The accuracy of Gas Chromatography (GC) analyses is compound- and matrix-dependent. Thus matrix spike recovery is used to determine the effect of the matrix, and a laboratory control sample is used to determine accuracy of the analyses. The recovery of analytes in a soil matrix is often lower than that obtainable for liquid matrices. As for precision, replicate standards and/or spiked samples will be used to estimate the accuracy of 5 percent (1 in 20) of analytical test procedures for a known matrix.

B.3.3 COMPLETENESS

The completeness of the data is the amount of valid data obtained from the measurement system (field and laboratory) versus the amount of data expected from the system. At the end of each sampling event, an assessment of the completeness of data will be performed and, if any sample omissions are apparent, an attempt will be made to resample if feasible. Resampling for laboratory analyses is not feasible, therefore, it is critical that holding times are met and that the laboratory inform the deputy project manager if any containers were broken during shipping. In addition, data completeness will be assessed prior to the preparation of data reports.

B.3.4 REPRESENTATIVENESS

Samples taken must be representative of the population. To assess the representativeness of the samples, some samples will be collected in duplicate. Comparisons of the results from the original sample and its field duplicate will allow for an evaluation of the representativeness of the samples.

B.3.5 COMPARABILITY

Where appropriate, the results of analyses obtained may be compared with the results obtained in previous studies. Consistency in the acquisition, handling, and analysis of samples by USEPA-recommended procedures is necessary in order that the results may be compared. To this end, standard solutions and materials used in calibrating field and laboratory analytical instruments must be traceable to National Bureau of Standards (NBS) or EPA standards, and published analytical methods will be followed. Any deviations from the specified analytical protocol will be documented by the laboratory.

B.4 SAMPLE HANDLING, SAMPLE RECEIPT

B.4.1 SAMPLE HANDLING, PACKAGING, AND SHIPMENT

B.4.1.1 Sample Containers

Laboratory samples will be placed in pre-cleaned glass bottles, pre-cleaned Shelby Tubes, and evacuated SUMMA® canisters as listed on Table B.1. The samples will be carefully packed for shipment. The pre-cleaned bottles, brass tubes, and SUMMA® canisters will be obtained from the analytical laboratory. If necessary, individual sample bottles will be wrapped in bubble pack to prevent breakage during transport to the lab. The bottles will be placed into insulated shipping coolers with a plastic bag of ice. A Chain-of-Custody Record describing the contents of the cooler will be placed in a sealed plastic bag and taped to the upper lid of the cooler. When coolers are delivered to the shipping company, they will be taped shut with security labels taped over opposite ends of the lid.

B.4.1.2 Sample Sealing and Labeling

Laboratory sample containers will be sealed with a custody seal. See Figure B.1 for a custody seal. Also on Figure B.1 is a sample label. The label will include the sample numbers assigned according to the sample numbering system.

B.4.1.3 Sample Numbering System

Each laboratory sample will be assigned a unique sample identification number that describes where the sample was collected. Each number will consist of a group of letters and numbers, separated by hyphens. The sample numbering system to be used on this project is presented on Table B.2.

B.4.1.4 Preservatives and Holding Times

After samples have been taken, they will be delivered to the laboratory for analysis as soon as possible after collection in order to ensure that the most reliable and accurate answers will be obtained as a result of the analysis. Holding times and preservation methods are specified in Table B.1. The holding time begins from the date of collection in the field.

B.4.2 SHIPPING REQUIREMENTS

Shipping containers will be secured by using nylon strapping tape and custody seals to ensure that the samples have not been disturbed during transport. The custody seals will be placed on the containers so they cannot be opened without breaking the seal.

Soil samples which must be kept cool shall be shipped in insulated containers with either freezer forms or ice. If ice is used, it must be placed in a container so that the water will not fill the cooler as the ice melts. The samples will be delivered as soon as possible after collection to allow the laboratory to meet holding times.

Copies of the signed Chain-of-Custody forms will be delivered with the data packages. The originals will remain on file with the laboratory.

FIGURE B.1
SAMPLE CUSTODY SEAL AND SAMPLE LABEL

CUSTODY SEAL

_____	ENGINEERING-SCIENCE INC.
Date _____	1700 Broadway, Suite 900
_____	Denver, Colorado 80290
Signature _____	

SAMPLE IDENTIFICATION LABEL

Ship To:	PACE LABORATORY 11 Digital Drive Novato, California 94949 Attn: Stacy Hock (415) 883-6100
Sample ID: _____	Project Name: <u>AFCEE BIOVENTING</u>
ES Project NO.: <u>DE268. ____ .08</u>	Field Personnel: _____
Base: _____	Site: _____
Date: _____	Time: _____
Analyses: _____	_____
Preservation: _____	_____
Comments: _____	_____

TABLE B.2

SAMPLE NUMBERING SYSTEM

The Sample Numbering System includes 3 identifying pieces of information separated by hypens:

[Code for Site] - [Code for Location] - [Depth]

Code for Site - by site provided on Table C.3.

Code for Location - a two letter prefix and letter (indicating which A, B, C only when necessary) will indicate the sample location.

VW - Vent well
MP - Monitoring point
BG - Background well
EB - Exploratory boring or other
boring not completed as one of the above

Depth - from the surface where the sample is gathered

Example Sample Numbers

M2 - VW - 12: Sample from site #2 at Millersworth AFB from a depth of 12 feet from the vent well boring.

M2 - MPC - 28: Sample from site #2 at Millersworth AFB from a depth of 28 feet from the monitoring point C boring.

M2 - BG - 4: Sample from site #2 Millersworth AFB from a depth of 4 feet from the background boring.

B.4.3 SHIPPING ADDRESSES

B.4.3.1 SOIL SAMPLES

All soil samples will be shipped to the PACE Laboratory
PACE Laboratory
11 Digital Drive
Novato, CA 94949
Attention: Stacy Hock
Phone: (415) 883-6100

B.4.3.2 SOIL GAS SAMPLES

Air Toxics LTD
11325 Sunrise Gold Circle, Suite 4
180 Blue Ravine Road, Suite B
Folsom, California 95630
Attention: Alexis Merydith
Phone: (916) 638-985-1000

B.4.4 SAMPLE RECEIPT

The laboratory will sign the Chain-of-Custody upon receipt, keep the original, and immediately send a signed copy, which describes sample conditions upon receipt, back to the deputy project manager. The condition of the samples and temperature of the cooler will be documented in a signed, dated, and bound log book and on the Chain-of-Custody form with signature and date of person checking samples. If any breakage or discrepancy arises between Chain-of-Custody, sample labels, and requested analysis, the sample custodian will notify the ES deputy project manager immediately. Any breakage, discrepancy, or improper preservation will be noted by the laboratory as an out-of-control form with the corrective action taken. The out-of-control form will be signed and dated by the custodian and any other person responsible for corrective action.

B.5 SAMPLE CUSTODY

All samples will be accompanied by a Chain-of-Custody Record, examples of which are shown in Figures B.2 and B.3. A Chain-of-Custody Record will accompany the sample during shipment to the laboratory and through the laboratory. The Site Manager will fax a copy of each Chain-of-Custody Record to the project administrator, ES Denver (303) 831-8208 for tracking purposes.

The information provided on the Chain-of-Custody Record will include:

- The project name and the Air Force Base name;
- The signature of the samplers;
- The sampling station number or sample number;
- Date and time of collection;

- Grab or sample designation;
- A brief description of the type of sample and sampling location;
- Signature of individuals involved in the sample transfer;
- The time and date they receive the sample;
- The type of matrix;
- The preservatives used; and
- The analytical methods required; and
- The number of containers of each sample.

Chain-of-Custody Records initiated in the field shall be placed in a plastic cover and taped to the inside of the shipping containers used for sample transport from the field to the laboratory. This record will be used to document sample custody transfer from the field sampler to the laboratory or to an ES office.

B.5.1 SAMPLE CUSTODY

A sample is under custody if:

- it is in your actual possession; or
- it is in your view, after being in your physical possession; or
- it was in your physical possession and then you locked it up to prevent tampering; or
- it is in a designated and identified secure area.

B.5.2 TRANSFER OF CUSTODY AND SHIPMENT

The following procedures will be used in transferring and shipping samples:

- Samples are accompanied by a Chain-of-Custody Record. When transferring the possession of samples, the individuals relinquishing and receiving will sign, date, and note the time on the Record. This Record documents transfer of custody of samples from the field sampler to another person, or to the laboratory.
- Samples will be properly packaged for shipment and dispatched to the appropriate laboratory for analysis with a separate signed Chain-of-Custody Record enclosed in each sample box or cooler. The Chain-of-Custody Records will be numbered 1 of N, 2 of N, ..., where N is equal to the number of coolers shipped each day.
- Whenever samples are split with a facility or government agency, a separate Chain-of-Custody Record will be prepared for those samples and marked to indicate with whom the samples are being split.
- All packages will be accompanied by the Chain-of-Custody Record showing identification of the contents. The original Record will accompany the

shipment and copies will be retained by the site manager and in the ES Denver office.

B.5.3 LABORATORY CUSTODY PROCEDURES

The analytical laboratory will, as a minimum, record the temperature of the shipping container, check all incoming samples for integrity, and note any observations on the original Chain-of-Custody Record. Each sample will be logged into the laboratory system by assigning it a unique sample number. This number and the field sample identification number will be recorded on the laboratory report. Samples will be stored and analyzed according to specific USEPA methods. After the project is completed, the original Chain-of-Custody Record will be returned to the project manager for permanent storage.

The following procedures will be used by the laboratory sample custodian in maintaining the Chain-of-Custody once the samples have arrived at the laboratory:

- The samples received by the laboratory will be cross-checked to verify that the information on the sample labels matches that on the Chain-of-Custody record included with the shipment;
- If all data and samples are correct, and there has been no tampering with the custody seals, the "received by laboratory" box is signed and dated; and
- The samples will be distributed to the appropriate analysts, with names of individuals who receive samples to be recorded in internal laboratory records.

For data that are input by an analyst and processed using a computer, a copy of the input shall be kept and identified with the project number and other information as needed.

If the data are directly acquired from instrumentation and processed, the analyst will verify that the following are correct:

- Project and sample numbers;
- Calibration constants and response factors;
- Output parameters such as units of measurement; and
- Numerical values used for detection limits if a value is reported as "less than".

B.6 CALIBRATION PROCEDURES AND FREQUENCY

See Test Wells and Equipment, Section 4, of the Protocol Document.

B.7 ANALYTICAL PROCEDURES

Specific chemical parameters for the sampling program were selected based on suspected contaminants released at the Air Force Bases. The analytical program was designed to qualify and quantify the effect of bioventing on a variety of soil types, contamination concentrations, and under different climatic conditions.

B.7.1 ANALYSES FOR ORGANIC COMPOUNDS AND PHYSICAL PARAMETERS

All analyses will be performed within the holding times recommended for the specific test procedure and sample matrix. Samples will be collected and shipped in EPA recommended sample containers and preserved as required for specific tests as specified on Table B.1.

B.7.2 DETECTION LIMITS

The method detection limits (MDL) for the analyses described above are summarized in Table B.1.

B.8 DATA REDUCTION, VALIDATION AND REPORTING

B.8.1 FIELD MEASUREMENT DATA

Field measurements will be made by the site manager or the test engineer. The following standard reporting units will be used during all phases of the project:

- Pressure will be reported to 0.1 standard units on 5", 10", and 15" magnehelics, and reported in inches on larger magnehelics;
- O₂ and CO₂ will be reported to 0.1 percent;
- TVH will be reported in ppmv on the appropriate scale;
- Helium will be reported to 0.1 percent;
- Ambient temperature will be reported to the nearest 0.5 C;
- Soil temperature will be reported to 0.1 C; and
- Soil sampling depths will be reported to the nearest 0.5 foot.

Field data will be validated using three different procedures:

- Routine checks will be made during the processing of data. An example is looking for errors in identification codes.
- Internal consistency of a data set will be evaluated. This step may involve plotting the data and testing for outliers.
- Checks may be made for consistency with parallel data sets, that is, data sets obtained presumably from the same population (for example, from the same region of the aquifer or volume of soil).

The purpose of these validation checks and tests is to identify outliers; that is, an observation that does not conform to the pattern established by other observations. Outliers may be the result of transcription errors or instrumental breakdowns. Outliers may also be manifestations of a greater degree of spatial or temporal variability than expected.

After an outlier has been identified, a decision concerning its fate must be rendered. Obvious mistakes in data will be corrected when possible, and the correct value will be inserted. If the correct value cannot be obtained, the data may be

excluded. An attempt will be made to explain the existence of the outlier. If no plausible explanation can be found for the outlier, it may be excluded, but a note to that effect will be included in the report.

B.8.2 DATA ANALYSIS AND REPORTING

During data analysis and report preparation, the accuracy of numbers, calculations, tables, and figures will be reviewed and confirmed. In addition, the technical content of the report will be reviewed by the Project Manager and the report will be edited for syntax, grammar, composition, and printed quality. Data will be reported in AFCEE level 1 format. Data analysis reports will be issued to ES Denver within 30 days of receipt of samples. All data packages will be submitted to the deputy project manager and will include soil and soil gas analysis results. A copy of the Chain-of-Custody Record will be submitted with the analysis results.

B.8.3 MAINTENANCE OF PROJECT DOCUMENTS

See Procedures and Controls of the PMP, Section 5.

B.9 FIELD AND LABORATORY CONTROL CHECKS

B.9.1 FIELD QUALITY CONTROL SAMPLES

During each sampling effort, a number of quality control (QC) samples must be collected and submitted for laboratory analysis. The number and frequency of the QC sample collection will be 5 percent (or 1 in 20 samples). A list of the types of QC sample collection will be 5 (or 1 in 20 samples). A list of the types of QC samples that shall be collected along with a brief description of each sample type is outlined in the following sections.

B.9.1.1 Field Duplicates

Five percent of all soil and soil gas samples will be collected in duplicate and submitted for laboratory analysis. Field duplicates will be labeled in such a manner so that persons performing laboratory analyses are not able to distinguish duplicates from other collected samples.

B.9.2 LABORATORY QA/QC SAMPLES

Quality control data are necessary to determine the absence of interferences and contamination of glassware and reagents. All method QA/QC is applied to each sample set at a method-specified frequency; matrix spike and spike duplicate analyses are performed for each matrix type. Duplicate samples and/or matrix spike duplicate samples will be analyzed with each set of samples, one every 20 samples or 5 percent.

B.9.2.1 Analytical Duplicate Analyses

Analytical duplicate samples are aliquots of a single sample that are split on arrival at the laboratory or upon analysis.

B.9.2.2 Matrix Spike/Duplicate Spike Analyses

This technique is used to determine the effect of matrix interference on the results for the GC/MS methods. Aliquots of the same sample are prepared in the laboratory and each aliquot is treated exactly the same throughout the analytical method. Spikes are added at concentrations specified in the method. The percent difference between the values of the duplicates is taken as a measure of the precision of the analytical method.

Selected samples will be spiked to determine accuracy as a percentage recovery of the analyte from the sample matrix. These matrix spikes will be prepared using reagent grade salts, pure compounds, or certified stock solutions whenever possible. Concentrated solutions will be used to minimize differences in the sample matrix resulting from dilution. Samples will be randomly selected and split into identical duplicates, one of which will then be spiked with a known mass of the analyte to be determined. The final concentration after spiking should be within the same range as the samples being analyzed to avoid the need for dilution, attenuation of instrument outputs, or other required alterations in the procedure which might affect the instrument response and determination of accuracy. A matrix spike duplicate sample is prepared in the same manner as the matrix spike sample.

B.10 PREVENTIVE MAINTENANCE

All field equipment, instruments, tools, gauges, and other items requiring preventive maintenance will be serviced in accordance with the manufacturer's specified recommendations. Maintenance records will be documented and traceable to specific equipment.

All laboratory instruments will be maintained in accordance with the standard operating procedures for each instrument. All maintenance will be documented for each analytical instrument.

B.11 CORRECTIVE ACTION

The following procedures have been established to assure that conditions adverse to quality including malfunctions, deficiencies, deviations, and errors are promptly investigated, documented, evaluated, and corrected.

When a significant condition adverse to quality is noted at the project site, laboratory, or subcontractor locations, the cause of the condition will be determined and corrective action taken to preclude repetition. Condition identification, cause, reference documents, and corrective action planned to be taken will be documented and reported to the Project Manager, Quality Assurance Manager, Site Investigation Geologist, and involved subcontractor management, as a minimum. Implementation of corrective action will be verified by documented follow-up action. All project personnel have the responsibility, as part of the normal work duties, to promptly identify, solicit approved correction, and report conditions adverse to quality.

Corrective actions may be initiated as a minimum:

- When predetermined acceptance standards are not attained (objectives for precision, accuracy and completeness);
- When procedures or data compiled are determined to be faulty;
- When equipment or instrumentation is found faulty;
- When samples and test results cannot be traced with certainty;
- When quality assurance requirements have been violated;
- When designated approvals have been circumvented;
- As a result of system and performance audits;
- As a result of a management assessment; or
- As a result of QA audits.

B.12 QUALITY ASSURANCE AUDITS

A quality assurance audit will be performed at least once in each regional office by the Quality Assurance Manager (QAM) or designated alternate. This audit will be performed to evaluate implementation of the QA/QC Plan, and the performance of project personnel, items, activities, and documentation of the measurement systems.

APPENDIX C
FIELD SAMPLING PLAN

CONTENTS

	Page
C.1 Field Operations.....	C-1
C.1.1 Site Reconnaissance and Preparation Procedures.....	C-1
C.1.2 Soil Organic Vapor Survey Procedures.....	C-1
C.1.3 Installation of Vent, Monitoring and Background Wells.....	C-3
C.1.4 Well Abandonment and Waste Handling.....	C-3
C.2 Environmental Sampling Procedures	C-5
C.2.1 Soil Sampling Procedures.....	C-5
C.2.1.1 Soil Sampling for BTEX and TRPH.....	C-5
C.2.1.2 Soil Sampling for Physical Parameters.....	C-5
C.2.2 Soil Gas Sampling Procedures.....	C-5
C.3 Sample Handling.....	C-7
C.3.1 Soil Samples	C-7
C.3.2 Soil Gas Samples	C-7
C.4 Field Measurements	C-10
C.5 Field QA/QC Program.....	C-10
C.6 Bioventing Pilot Test	C-10
C.7 Systems Operation and Monitoring	C-10
C.7.1 Pressure/Vacuum Monitoring.....	C-10
C.7.2 Temperature Monitoring.....	C-10
C.7.3 Helium Monitoring.....	C-10
C.7.4 Oxygen and Carbon Dioxide Monitoring.....	C-10
C.7.5 Total Volatile Hydrocarbons.....	C-13

LIST OF TABLES

No.	Title	Page
C.1	Sample Analysis Type, Number, Container, Method, Preservative, Holding Time, Reporting Units and Limits, and QA Objectives	C-6
C.2	Field Measurements.....	C-11
C.3	Control Parameters, Control Limits, and Corrective Actions.....	C-12

CONTENTS (Continued)

LIST OF FIGURES

No.	Title	Page
C.1	Sample Field Log Book	C-2
C.2	Geologic Boring Log	C-4
C.3	Typical Well Head Configuration for Soil Gas Sampling	C-8
C.4	Sample Collection Instructions and Canister Diagram	C-9

APPENDIX C

FIELD SAMPLING PLAN

C.1 FIELD OPERATIONS

This field sampling plan (FSP) provides guidance for the field procedures to be followed while conducting the activities specified in the Test Plan and Technical Protocol for field Treatability Test for Bioventing (Protocol Document). The following contains procedures for typical venting/bioremediation test activities. Any additional activities specified will be identified in the site-specific test plan.

C.1.1 Site Reconnaissance and Preparation Procedures

Site reconnaissance and preparation procedures include a review of existing site data and an initial base meeting. These are described in the Project Management Plan (PMP) Section 4.2 (page 4-1).

C.1.2 Soil Organic Vapor Survey Procedures

Soil organic vapor (SOV) surveys will be performed to locate the optimum test area. For contamination 20 ft deep or less, an initial soil gas survey will be performed to locate areas of depleted oxygen. For contamination deeper than 20 ft, exploratory borings will be drilled. See the Protocol Document (pages 41, 42, and 43) for procedures for performing the soil gas survey or to identify contaminated soils using exploratory borings.

All soil gas survey and exploratory boring information as well as all other field activity information will be recorded in a permanently bound notebook with sequentially numbered pages.

The date, job number, and initials will be recorded at the top of each page. A sample field log book is included as Figure C.1. Minimum information required for each entry includes:

- Time (recorded in the column under the date),
- Ambient temperature (°F),
- Weather conditions during previous 24 hours,
- Persons performing the soil gas survey drilling oversight, sampling, or testing,
- Drilling and well construction information,
- Site identification,

FIGURE C.1

SAMPLE FIELD LOG BOOK

Time	Activity	Notes	Depth
4/10/91	Drive At Site	Establish Datum	3:30
7:30	Establish Datum	Establish Datum	3:30
8:20	Begin Drilling Log on Existing Log	from grab samples	22' 1/2"
9:00	Collect Split Spore Sample PMPY-1		24' 0"
9:15	Install Construction Well		26' 1"
9:30	Finish Well Construction		30'
9:35	Begin		

Time	Activity	Notes	Depth
4/10/91	Drive At Site	Establish Datum	3:30
7:30	Establish Datum	Establish Datum	3:30
8:20	Begin Drilling Log on Existing Log	from grab samples	22' 1/2"
9:00	Collect Split Spore Sample PMPY-1		24' 0"
9:15	Install Construction Well		26' 1"
9:30	Finish Well Construction		30'
9:35	Begin		

- Sampling location,
- Sample number,
- Sample media (soil or air),
- Sample type (grab, composite, etc.),
- Sample description,
- Test information including O₂, CO₂ and TVH soil gas concentrations recorded on separate data sheets,
- Chemical analysis to be performed,
- Preservation method,
- Laboratory to which samples were sent and air bill numbers, if applicable,
- Photo numbers and description,
- Equipment decontaminated and procedures utilized,
- Equipment serial numbers,
- Calibrations,
- Field measurements not recorded on other data sheets,
- Description of extended blower test equipment set up,
- Records of pertinent telephone conversations,
- Names, titles, and organization of any visitors entering the site, and
- Comments (suitable for reconstructing incident without memory).

All entries will be made in waterproof ink. Any errors will be corrected by drawing a single line through the mistake, and all corrections will be initialed and dated.

C.1.3 Installation of Vent, Monitoring, and Background Wells

See the Protocol Document Sections 5.2, 5.3, and 5.4 (page 44). Use Figure C.2 for logging each boring.

C.1.4 Well Abandonment and Waste Handling

ES will advise the Air Force on proper well abandonment techniques based on federal, state, and local regulations. Drill cuttings will be handled in accordance with base policy. ES drilling subcontractors may be required to drum drill cuttings for placement in the base hazardous material storage area. Drums will be labelled according to base procedures. Under no circumstances should ES personnel assume responsibility for disposal.



FIGURE C.2

Sheet of

GEOLOGIC BORING LOG

Project Number _____	Client _____	Date _____
Borehole ID _____	Borehole Diameter _____	Elevation _____
Drill Rig _____	Contractor _____	Depth _____
Temp (°F): _____	Weather _____	Geologist _____
	Drilling Medium _____	

Depth (ft.)	Proj. No.	USCS	Geologic Description	Samples		Sample Type	Blow Counts	Remarks TIP = Report/Reading (type)
				No.	Depth (ft.)			
1								
5								
10								
15								
20								
25								
30								
35								
40								

sl - silt	lv - clay	fs - fine	 SPLIT SPOON SAMPLE
cl - clay	lc - light	ml - medium	 GRAB SAMPLE
ml - medium	cl - clay	co - coarse	 WATER TABLE DRILLED
st - silt	sc - sand	sh - shales	
ss - silt	sl - silt	SAA - Same As Above	
st - silt	sl - silt	D - Driller	
st - silt	sl - silt		

ENGINEERING SCIENCE, INC.

C.2 ENVIRONMENTAL SAMPLING PROCEDURES

C.2.1 Soil Sampling Procedures

For the number, types of samples and corresponding containers see Table D-1. Initial and final soil samples will be collected from the following locations on each site:

- The most contaminated depth of the Vent Well (VW) which is the central injection or extraction well and
- Two monitoring points (MPs) including one sample from the most contaminated depths of the closest and the second closest MPs to the VW.

C.2.1.1 Soil Sampling for BTEX and TRPH

Soil samples will generally be obtained using a truck-mounted hollow-stem auger rig and split-spoon sampler containing brass tubes. The split-spoon sampler will be driven by a 140-pound drop hammer having a 30-inch drop. The sampler will be driven for its full length or until 6 inches, or less, of penetration is achieved after 50 blows.

If required by regulatory agencies, soil samples will be handled according to individual base sampling and analysis plans (SAP). If there is no established base SAP, immediately upon removal from the split-spoon sampler, the ends of one of the brass liners will be trimmed with a decontaminated stainless steel knife or spatula and sealed with oil-free aluminum foil or covered with a Teflon® fabric. The foil or fabric will be held in place on the ends of each tube by plastic caps sealed with tape. Soil in this liner will be extruded in the laboratory immediately prior to analysis for VOCs.

C.2.1.2 Soil Sampling for Physical Parameters

Soil in the remaining liners or soil from drill cuttings or hand augering will be placed into appropriate sample containers (see Table C.1), or used for field measurement surveys and visual descriptions.

C.2.2 Soil Gas Sampling Procedures

The purpose of soil gas sampling and analysis is to determine the initial levels of benzene, toluene, ethylbenzene, and xylenes (BTEX) and total volatile hydrocarbons (TVH) in the soil gas to predict potential air emissions and to determine the reduction in BTEX and TVH during the one year test and to detect migration of these vapors from the source area.

Initial and final soil gas samples will be collected from the following locations on each site:

- Central injection or extraction well, VW and
- Two MPs including one sample from the closest MP where a soil sample has been taken and another gas sample from the furthest MP from the VW.

TABLE C.1
Sample Analysis Type, Number, and Container

SAMPLE MEDIUM	LABORATORY ANALYSIS TYPE	PARAMETER	APPROXIMATE NUMBER OF SOIL SAMPLES BY SITE		SAMPLE CONTAINER		PRESERVATIVE							
			INITIAL #	FINAL #	NUMBER	SIZE		TYPE						
SOIL	INORGANIC	pH ALKALINITY IRON, TOTAL SOIL MOISTURE CONTENT	3	0	1	4 OUNCE	GLASS	NONE						
									3	3	1	4 OUNCE	2" DIA. BRASS TUBE	HOLD AT 4 C
AIR	ORGANIC	BTEX AND TVII w/ MS/MSD per 20 project samples), triple sample volume; e.g. 3 brass tubes for BTEX and TRPH.	3	3	1	1 LITER	SUMMA (a) CANISTER	NONE DO NOT CHILL						

w/ On samples requiring MS/MSD (normally 1 MS/MSD per 20 project samples), triple sample volume; e.g. 3 brass tubes for BTEX and TRPH.
 v/ BTEX - benzene, toluene, ethylbenzene, and xylene.
 w/ TRPH - total recoverable petroleum hydrocarbons.
 x/ TVII - total volatile hydrocarbons.

Prior to collecting soil gas samples, the vent well and the monitoring points must be purged with a 1 CFM pump. approximately three times the well or probe volume should be purged. To determine adequate purging time, soil gas concentrations should be monitored until the concentrations stabilize or until the oxygen concentration reaches a minimum level. The CO₂/O₂ analyzer will be connected to the outlet of the sampling pump with a "tee" connection as shown in Figure 5.1 of the protocol document. The pump can be connected to the vent well using a combination of fittings as shown in Figure C.3. Soil gas samples should be taken immediately upon completion of purging.

A sample will be collected in a 1-liter evacuated stainless steel (SUMMA®) canister provided by the analytical laboratory. A simple checklist and diagram for operating these canisters is provided (Figure C.4). Because the canisters are evacuated, when they are opened, the sample is collected almost instantaneously. According to the laboratory, one does not need to record pressure and temperature because the samples are brought to standard pressure and temperature in the lab. One sample in twenty (5%) should be a field duplicate.

In silt and clay soils the soil gas sample will first be collected in a new 2-liter Tedlar® bag using a vacuum chamber (egg) connected to the vapor well. The Tedlar® bag will then be connected to the evacuated cylinder using a 6-inch section of clean Tygon® tubing. The gas is then transferred from the Tedlar® bag by first opening the Tedlar® bag valve and then opening the valve on the evacuated cylinder. The sample will transfer rapidly. Once the transfer is complete, the valve on the cylinder should be immediately closed and sealed with a piece of tape to prevent reopening.

In sandy soils, the evacuated cylinder can be connected directly to a purged vapor monitoring point and the cylinder valve opened to draw a soil gas sample from the well. Check to insure the gas sample is properly labelled using the nomenclature described in Section 4.2.3 of the Protocol Document.

C.3 SAMPLE HANDLING

C.3.1 Soil Samples

Sample handling is addressed in the QAPP in Appendix C. Site managers are responsible for contacting the PACE Laboratory to alert them to the number of samples that will be sent for analyses.

C.3.2 Soil Gas Samples

Samples and chain of custody form should be placed in a small cooler and packed with foam pellets to prevent excessive movement during shipment. Samples should not be sent on ice as this will cause condensation of hydrocarbons and degrade sample integrity.

Figure C.3 in graphics

FIGURE C.3
TYPICAL WELL HEAD CONFIGURATION FOR SOIL GAS SAMPLING

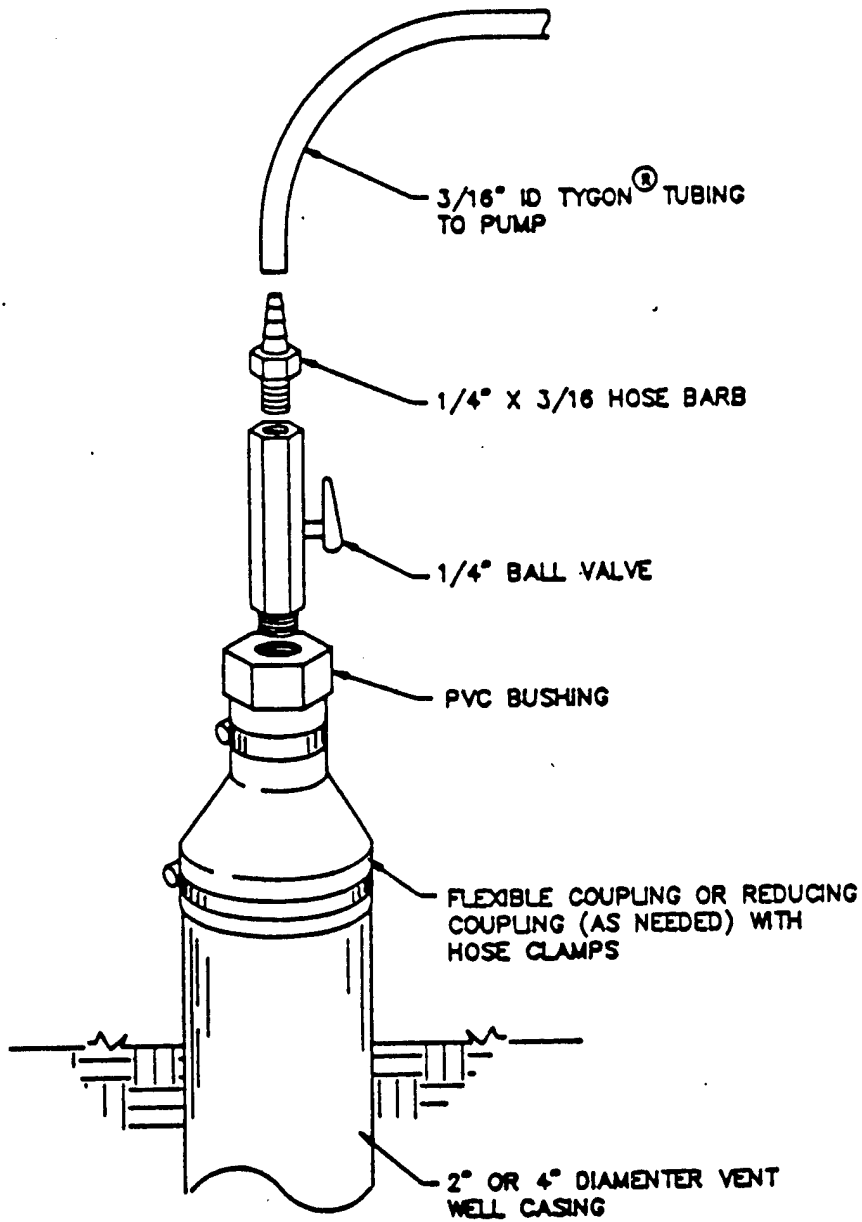

NOT TO SCALE

FIGURE C-4

INSTRUCTIONS FOR TAKING SAMPLES USING SUMMA® CANISTERS SUPPLEMENTAL REMEDIAL INVESTIGATION/FEASIBILITY STUDY LOWRY AIR FORCE BASE, COLORADO

Required Equipment:

Evacuated SUMMA® canisters
a 2-7 micron filter
a 1/2" open end wrench
a 9/16" open end wrench
a hose barb adapter to adapt the threaded fitting on the canister to 3/16" Tygon® tubing.

Assembly of the sampling hardware:

1. Remove the brass cap from the canister.
2. Connect the filter to the canister. Tighten the filter to the canister using the 9/16" wrench.
3. Connect the hose barb to the filter.
4. Connect the well head or the Tedlar® bag to the hose barb using 3/16" Tygon® tubing (using as short a connector as possible).

The assembly is now complete...sampling will commence when the valve on the canister (green handle) is opened.

The Final Step

When the sample interval is complete, close the valve (green handle) on the canister and remove the filter. It is not necessary to over-tighten the valve upon closing. Replace the brass cap. Fill out the sampling tracking tag. The canister may now be submitted to Analytical Technologies, Inc. for analysis.

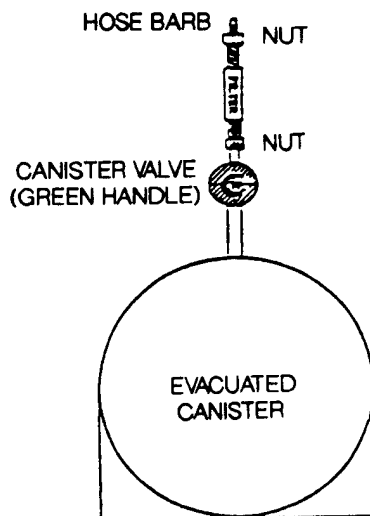

C.4 FIELD MEASUREMENTS

Typical field parameters that may be measured and the equipment that will be used for the measurements are described in Table C.2. Details of the equipment calibration, maintenance, and decontamination are also described in Table C.3.

C.5 FIELD QA/QC PROGRAM

Field measurement parameters, control checks, control limits, and corrective actions are identified in Table C.3.

C.6 BIOVENTING PILOT TEST

See the Protocol Document (pages 46-60).

C.7 FIELD SYSTEMS OPERATION AND MONITORING

C.7.1 Pressure/Vacuum Monitoring

Dwyer Instruments Magnehelic® gauges with a range of 0 to 200 inches of water-column will be used to measure pressure/vacuum at the VMPs. The pressure/vacuum measurements will be taken manually by connecting the Magnehelic® gauge to each VMP. The gauges should be read to 0.1 of the smallest standard unit.

Operating time for each test will be recorded from the time the blower is turned on. Pressure/vacuum at each VMP, and at each measurement location on the vacuum extraction (VE) unit, will be recorded at 1, 5, 10, 15, 20, 30, 40, 50, and 60 minutes, and every 60 minutes thereafter. After the initial 12 hours of operation, vacuum measurements will be recorded every 4 to 8 hours.

C.7.2 Temperature Monitoring

Ambient temperature will be measured using a mercury thermometer during the use of direct reading instruments to account for data variability possibly due to temperature.

Soil temperature will be measured using type J thermocouples placed at a minimum of two MPs per site.

C.7.3 Helium Monitoring

Helium concentrations in extracted soil gas will be measured using a Marks Helium Detector 9821. The instrument is factory calibrated but should be checked with a 1 percent helium standard to insure it remains within ± 5 percent of factory calibration.

C.7.4 Oxygen and Carbon Dioxide Monitoring

Both oxygen and carbon dioxide will be monitored with a Gastehtor® Model 3252OX gas analyzer. This instrument includes an infrared detector for carbon dioxide and an electrochemical cell for oxygen analysis, and is capable of measuring both compounds to within an accuracy of 0.1 percent. The instrument requires daily

TABLE C.2

FIELD MEASUREMENTS

PARAMETER	EQUIPMENT	CALIBRATION	SOURCE OF CALIBRATION STANDARDS	EQUIPMENT MAINTENANCE	EQUIPMENT DECONTAMINATION
Pressure/ Vacuum	Dwyer Instruments Magnohelic® Gauge	Calibrated By Manufacturer	Not Applicable	Replace in case of malfunction	Not Applicable
Temperature	Mercury Thermometer	Calibrated by Manufacturer	Not Applicable	Replace in case of malfunction	Rinse thermometer with distilled water after each use and blot or shake to remove excess water.
Soil Temperature	Type J Thermocouple	Check with ambient temperature and ice	Mercury thermometer	Follow manufacturers procedures	Rinse probe with distilled water. Remove excess water.
Helium	Marks Helium	Calibrated by Manufacture	Not Applicable	Follow manufacturers procedures	Rinse probe with distilled water. Remove excess water.
O ₂ /CO ₂	GasTech® Analyzer	Two-point calibration	Commercially available gas mixes	Follow manufacturers procedures	Rinse probe with distilled water. Remove excess water.
Total Volatile Hydrocarbons	GasTech® Analyzer	Two-point calibration	Commercially available gas mixes	Follow manufacturers procedures	Rinse probe with distilled water. Remove excess water.

G-11

Table C.3

CONTROL PARAMETERS, CONTROL LIMITS, AND CORRECTIVE ACTIONS

Measurement Parameter	Control Checks	Control Limits	Corrective Action ^{a/}
Pressure/ Vacuum	Check measurement	± 1" water	Replace gauge
Temperature	Check measurement	± 1 degree centigrade	Replace thermometer or correct temperature readings
Soil Temperature	Check measurement	± 1 degree centigrade	Replace thermocouple or return reader to manufacturer
Helium	Calibration Std.	± 5% of value	If calibration exceeds ± 5%, return to manufacturer Check battery Clean Filter
O ₂ /CO ₂	Calibrate Stds.	± 5% of value	Recalibrate Check battery Clean Filter
Total Volatile Hydrocarbons	Calibrate Daily Check Battery	± 100ppm	Recalibrate Check battery Clean Filter

a/ Required if control limits not achieved

calibration with a 5 percent carbon dioxide gas mixed in laboratory-grade nitrogen. The same calibration gas can also be used to provide a zero for oxygen.

C.7.5 Total Volatile Hydrocarbons

Hydrocarbon concentrations in extracted soil gas will be measured using a GasTech® Trace-Tector Hydrocarbon Analyzer, model 72-8418E-O2.

APPENDIX D
ES ADDENDUM TO TECHNICAL PROTOCOL

ES ADDENDUM TO PROTOCOL DOCUMENT

INSERT 1. p. 27 Add to criteria 4

At sites that will have underground piping between the blower and vent well, the upper 18-inches of annular space will be left open to allow access for below-grade well head completion.

INSERT 2. p 31 Replace first three paragraphs

Monitoring point construction will vary depending on the depth of drilling, drilling technique, and soil and hydrologic conditions. Basically, the monitoring points will consist of rigid, 1/4-inch inside diameter, Schedule 80 PVC pipe to the specified depth with a 6-inch length of 1-inch diameter Schedule 40 PVC well screen with 0.020-inch slots. Each monitoring point screen will be centered within a 1 to 2 foot thick sand pack consisting of clean, rounded silica sand with a 6-9 sieve grain size. In low permeability soils, a slightly longer sand pack may be desirable. In wet soils, and where the depth to the groundwater surface fluctuates greatly, a longer sand pack with the screen near the top may be desirable. An approximately 1-foot thick sand pack will also be placed directly below the well box to provide drainage.

The annular space between sand packs will be filled with bentonite to form air-tight seals between sampling intervals. The bentonite seals will be hydrated in place instead of using bentonite slurry to assure long-term integrity of the seals. Bentonite slurry emplaced in monitoring points constructed in dry and/or sandy soils may dehydrate and shrink with time, resulting in the loss of the seal and settling or collapse of the overlying sand pack. The 2 feet of bentonite immediately above and below the annular sand pack intervals will consist of 1/4-inch diameter sodium bentonite pellets or granular bentonite less than 1/4-inch in diameter. These 2-foot thick intervals will be placed in 6-inch layers and each layer hydrated with potable water before placement of subsequent layers. To assure adequate hydration of each 6-inch bentonite layer, the water will be added in 2 or 3 portions with sufficient time allowed between additions to allow for hydration. The bentonite is sufficiently hydrated when the water will no longer penetrate the seal. Backfill between bentonite seals will consist of bentonite chips (hole plug) hydrated in place with potable water.

PVC pipe will be used to collect soil gas for CO₂ and O₂ analysis in the 0.25% range, and for JP-4 hydrocarbons in the 100 ppm range or higher. The pipe material must have sufficient strength and be nonreactive. Sorption and gas interaction with the pipe materials have not been significant problems for this application. If a monitoring point will be used to monitor specific organics in the low ppm or ppb range, Teflon[®] or stainless steel may be necessary. However, this will not normally be the case.

The top of each ¼ inch PVC pipe will be finished with a ¼ inch ball valve fitted with a 3/16 inch hose barb. Each screened depth will be labeled using aluminum tags with a name as follows:

INSERT 3. p. 33, Section 4.2.4 Replace 3rd sentence

Type K (chromel-Alumel) thermocouples with Type K mini connectors will be used.

INSERT 4. p. 33 Replace Section 4.3

4.3 Background Monitoring Point

In addition to the vent well and the monitoring points installed in contaminated soils, a background monitoring point will be installed in uncontaminated soil to monitor the background respiration of natural organic matter. Soil gas in uncontaminated soil generally has O₂ levels between 15 and 20% and CO₂ levels between 1 and 5%. The background monitoring point will be similar in construction to the monitoring points installed in contaminated soils (Figure 4-2) and screened at similar depths in the same stratigraphic formation.

Alternatively, an existing groundwater monitoring well can be used as a background monitoring point if the well is installed in clean soils and the well screen extends several feet above the groundwater surface.

INSERT 5. p. 37 following 1st paragraph

WELL PURGING PROCEDURES

Prior to performing the following measurements and collecting soil gas samples, the vent well and monitoring point volumes must be purged. The purge volume should be approximately three times the vent well or monitoring point volume. Required purge volumes vary with length of sand pack, bore hole diameter and soil type. To determine adequate purging times for each sampling point, oxygen concentrations will be monitored during the initial purging until the concentrations reach a minimum value. Figure 5-1 shows a typical setup for the initial purging. For the vent well, this will depend on depth. For monitoring points and soil gas probes, this purging typically takes less than one minute using a one cubic foot per minute (cfm) pump. The required purge time will be recorded in the field book and used for all subsequent purging to ensure consistent measurements. Especially in fine-grained soils, it is important to avoid over-purging, which can draw in fresh, oxygenated air and result in erroneous measurements. Samples and measurements should be taken immediately upon completion of purging. **NOTE: FOR ANYTHING OTHER THAN SANDY SOILS THE SAMPLE MUST BE COLLECTED USING THE VACUUM CHAMBER (EGG).**

INSERT 6. p. 44 Replace title of Section 5.5

5.5 COLLECTION OF SOIL AND SOIL GAS SAMPLES

INSERT 7. p. 45 following 2nd paragraph

In addition to the listed soil analyses, two soil analyses will be performed to evaluate benzene toluene, ethylbenzene, and xylene (BTEX) and total recoverable petroleum hydrocarbons (TRPH) and three soil gas analyses will be performed to evaluate BTEX and total volatile hydrocarbon (TVH).

SOIL

For each additional soil sample to be analyzed for BTEX and TRPH, one 2" diameter by 6" length thin walled, brass tube taken from a split spoon sampler, will be provided. These samples must be preserved by shipping at 4°C.

SOIL GAS

For each soil gas analyses, one SUMMA® canister will be provided. This is not to be chilled or preserved for shipping.

INSERT 8. p. 48, Section 5.7.1, 1st paragraph, last sentence Figure 2-9 should read 5-2.

INSERT 9. p. 48, Section 5.7.1 following 1st paragraph.

HELIUM INJECTION

The key to successful helium diffusion testing is to provide a uniform injection concentration of helium. This requires regular checks on helium injection concentrations at the well head and may require adjustment of the two-stage regulator controlling helium and air injection to the monitoring point. A helium mixing device provided by ES-Denver will be used to inject a constant helium concentration into multiple wells.

INSERT 10. p. 53, Section 5.7.2, replaces 2nd paragraph.

Battelle and AFCEE have determined that helium loss cannot be quantitatively related to oxygen diffusion. Helium will be used as a conservative tracer to detect serious leakage or short-circuiting in each monitoring point used for respiration testing. If a monitoring point loses over 75% of its initial helium concentration in the first 1000 minutes of respiration testing, that monitoring point will be considered unacceptable for respiration testing.

INSERT 11. p. 29 Replace Figure 4-1 with the following figure.

2-4" DIAMETER SCH 40
PVC HEADER SLOPED
TO WELL

TO/FROM BLOWER

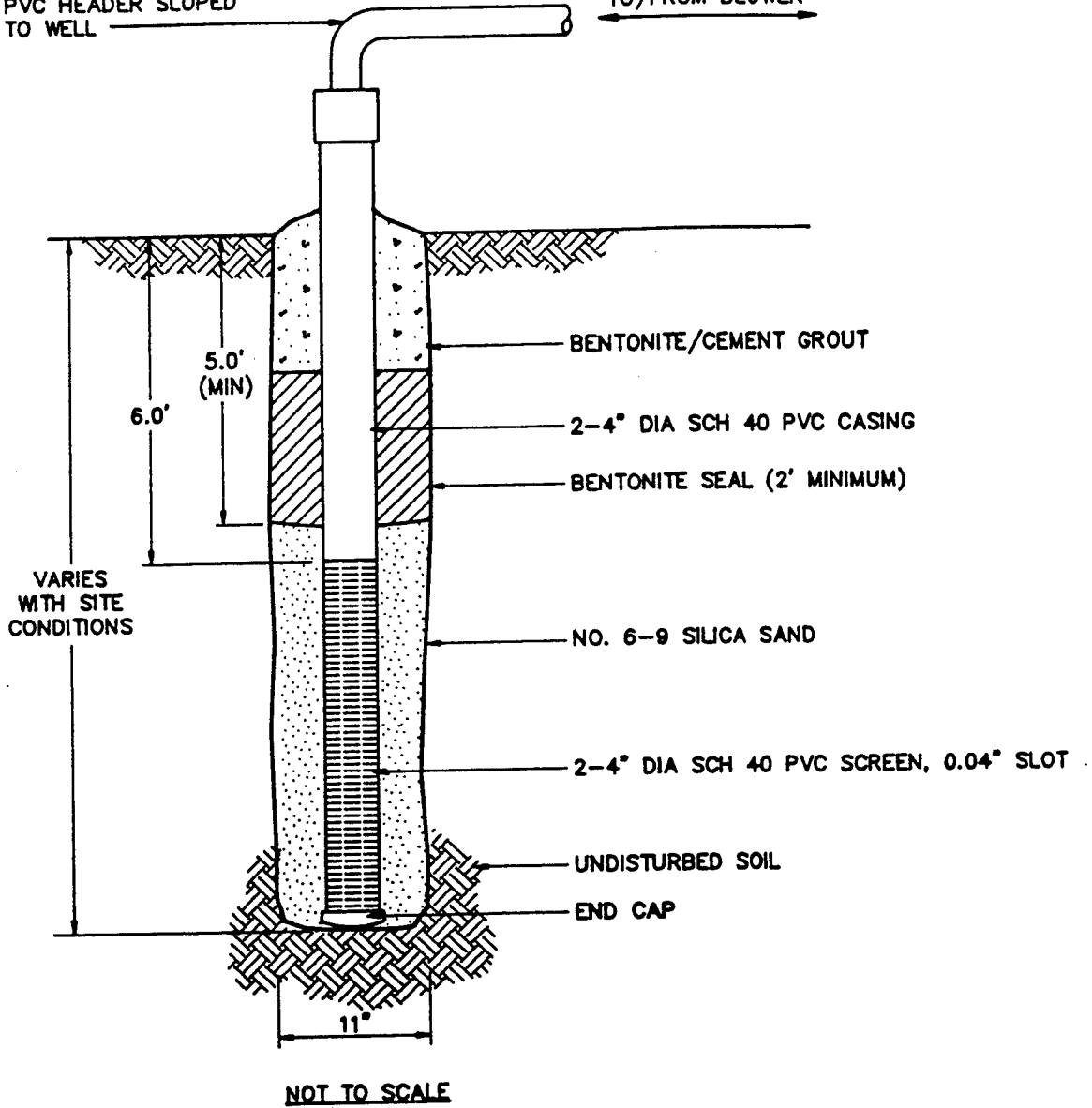

FIGURE D.5

TYPICAL
INJECTION/VACUUM VENTING
WELL CONSTRUCTION DETAIL

ENGINEERING-SCIENCE, INC.
Denver, Colorado



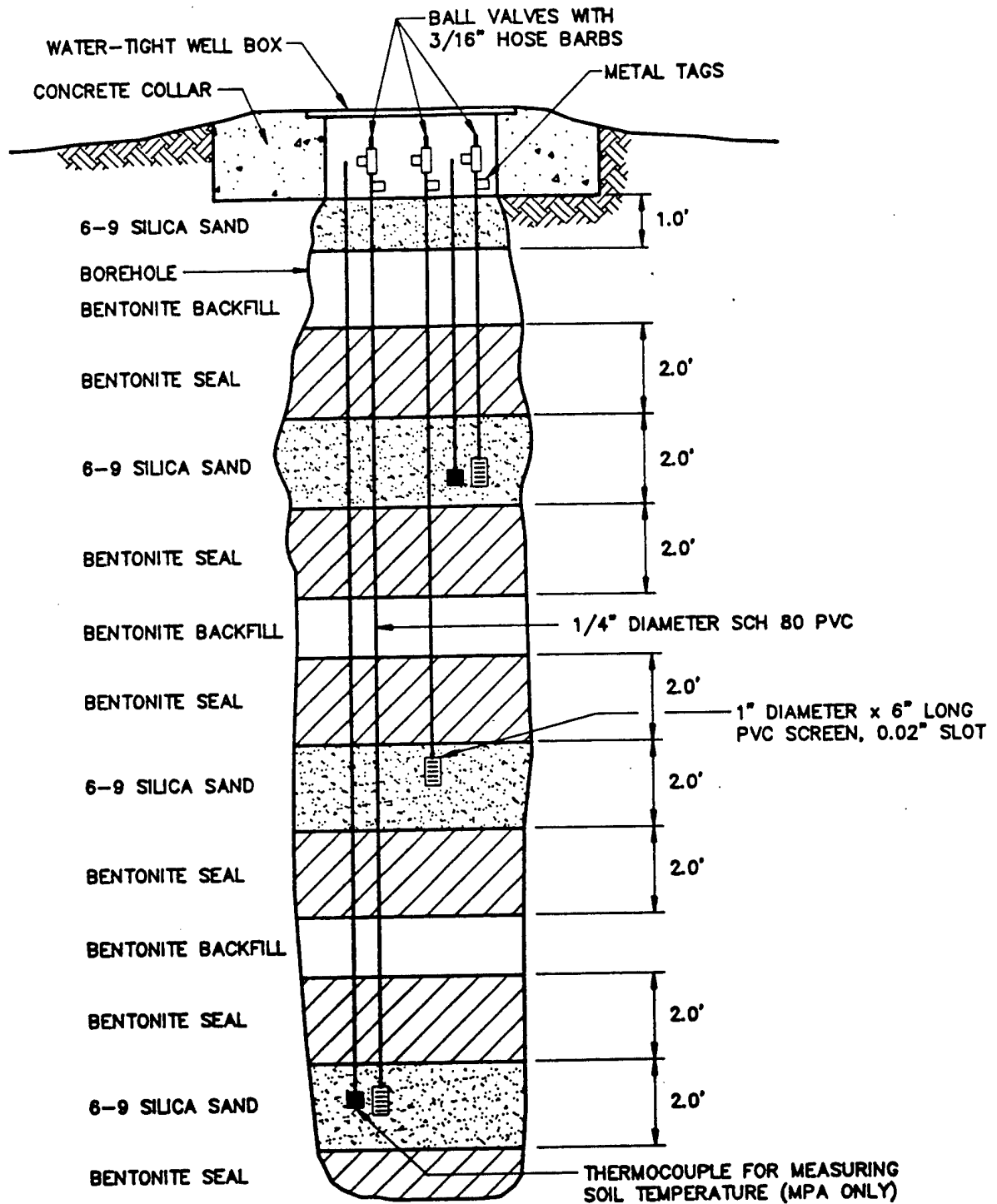

FIGURE D.6

TYPICAL MONITORING POINT
CONSTRUCTION DETAIL

ENGINEERING-SCIENCE, INC.
Denver, Colorado



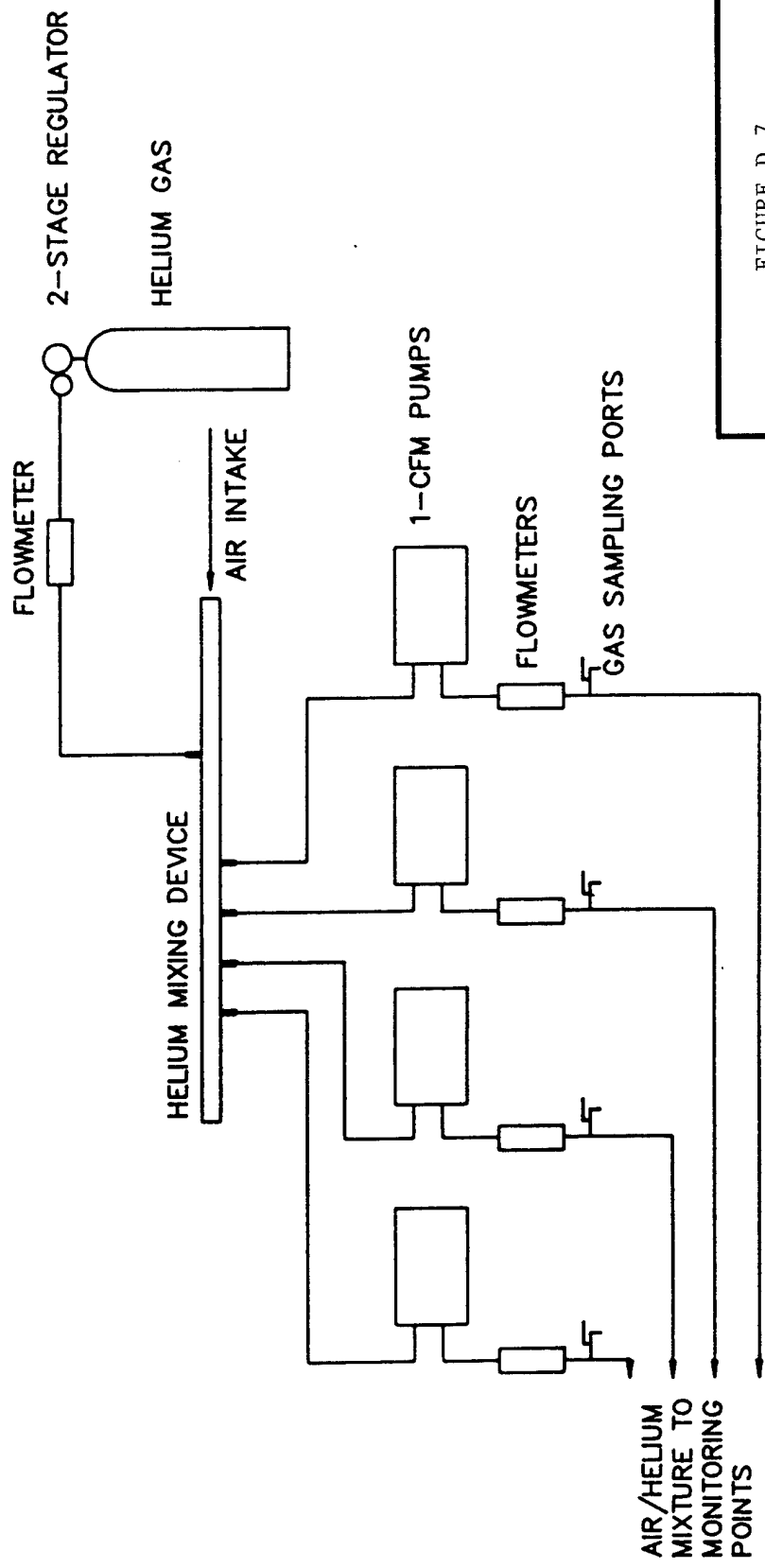

FIGURE D.7

TYPICAL AIR/HELIUM INJECTION APPARATUS FOR IN-SITU RESPIRATOR TESTS

PILOT TEST OUTLINE
AND
EQUIPMENT LIST

BIOVENTING PILOT TEST OUTLINE

1 PRE MOBILIZATION

- ELECTRICAL POWER READY?
- Air, drilling and other permits
- Work/Health and Safety Plans approved by base/regulators?
- Utilities cleared?
- Arrange to meet with electrician upon arriving on site
- Check supplies
- Hotel, airline, and vehicle rental reservations
- Security clearance information (ES and driller personnel)
- Potential background well information: existing groundwater monitoring well and/or location for new monitoring point outside contaminated area

2 DRILLING/SOIL SAMPLING

2.1 Pre-Drilling

- Meet with base contact
- Check utility clearance
- Soil gas survey: confirm low O₂ concentrations
- Locate water source
- Arrange for drum staging
- Establish decontamination area
- Drum labeling instructions/materials from base contact

2.2 Drilling

- Soil sampling: see Sampling Plan
- Collect one soil sample from VW, MPA, and MPB

2.3 MP Construction

- Install 2 thermocouples in MPA. Compare with mercury thermometer before installing

3 BASELINE MEASUREMENTS

- Purge MPs, VW; determine optimum purge times; check vacuum to determine if "egg" is needed for sampling
- Measure O₂, CO₂, and hydrocarbon concentrations
- Collect SUMMA air samples; MPA, MPC, VW
- Measure soil temperature

4. PERMEABILITY TEST

4.1 System Check

- Set-up, zero gages
- Measure initial pressures
- Check flow rate, injection pressure, pressure response at MPs
- Choose appropriate pressure gages

4.2 Permeability Test

- Run blower until steady state for pressure achieved and O₂ response measured at all/most MPs
- Measure post-test O₂, CO₂, and HC concentrations
- Measure soil temperature
- Begin respiration test for the VW

5. RESPIRATION TEST

- Continue measuring O₂, CO₂ and HC at VW
- Choose 3 or 4 MPs with low initial O₂ and high initial HC concentrations. Use MPs where soil samples collected.
- Inject helium/air mixture (2-5% Helium) using helium mixing manifold
- Inject air at background MP/well if initial O₂ concentration is less than 18 percent
- Inject air for 20 hours
- Measure flow rates and Helium concentrations during injection
- After injecting for 20 hours, begin measuring O₂, CO₂ HC, and helium concentrations
- Measure soil temperature

6. EXTENDED PILOT TEST BLOWER SYSTEM

- Set-up system
- Paint blower enclosure appropriate color to match nearby buildings; Check with base contact for proper color selection
- Measure O₂ concentrations at MPs
- Start blower and adjust air flow to VW. reduce air flow if short circuiting is occurring or strong fuel odor is noticed
- Check injection pressure, temperature, motor amps/voltage
- Set automatic pressure relief valve at or below maximum blower rating
- Set starter overload protection to 0.85 X amperage on motor nameplate (FLA) for single phase power
- If motor amperage too high, adjust manual bleed valve
- Run blower for approximately 24 hours and until O₂ change and pressure response is measured in all/most MPs
- Check injection pressure, temperature, relief valve setting (should not continuously release air), and motor amps. Make any necessary adjustments
- Train base personnel on system monitoring and maintenance
- Provide base with O&M manual (fill in the blanks !!), data sheets, and 2 spare filter elements (oil, grease, etc. for PD blowers)
- Leave key for blower enclosure with base contact

7. DEMOBILIZATION

- General site check
- Arrangement with base for disposal soil cuttings, decontamination water, etc.?
- Secure items in trailer; check trailer lights, brakes, tires, etc.

BIOVENTING PILOT TEST EQUIPMENT LIST

ITEM	NEEDED	NOT NEEDED	IN STOCK	ADD TO STOCK
------	--------	------------	----------	--------------

SOIL GAS SURVEY

Jack				
Hammer				
Probe set				
Spare screens				
Tygon tubing, 1/8"				
Probe tips				
Probe tip screens				

DRILLING, SOIL SAMPLING, AND AIR SAMPLING

Alconox				
Baggies				
Boring logs				
Brass liners				
Brushes				
Caps, plastic				
Chain-of-Custody forms				
Decon buckets				
DI water				
Field books				
Garbage bags				
Haz Waste labels				
Keys				
Labels				
Locks				
Pin flags				
Sample jars				
Sampling Plan				
SUMMA canisters and adaptor				
Teflon squares				
Trowels				
Work plans & reports				

MONITORING POINT & VENT WELL CONSTRUCTION

Aluminum tags				
Hose barbs				
MP Flush-mount covers, 8"				
MP Screen assemblies				
MP Tops				
Hose barbs, 1/4" NPT x 3/16"				
1/4" ball valve				
Threaded adaptor				
Thermocouples				
VW Flush-mount covers, 12"				

METERS ETC.

Calibration gas				
O2/CO2 (5% CO2, 95% nitrogen)				
Helium				
Hexane (4400 ppm)				
Digital thermometer (for thermocouples)				
O2/CO2 meter				
Block-type flow meters				
0-3 SCFH (helium injection)				
0-100 SCFH (1 CFM sampling/injection pumps)				
0-40 CFM (measure bleed air)				
Helium detector				
TVH analyzer				
2-Stage regulator (for helium)				
1-stage regulator (for calibration gas)				

ITEM	NEEDED	NOT NEEDED	IN STOCK	ADD TO STOCK
------	--------	------------	----------	--------------

AIR PERMEABILITY TEST

Data sheets				
Magnehelic pressure gages				
0-1"				
0-5"				
0-10"				
0-20"				
0-50"				
0-100"				
0-150"				
Pilot test P.D. blower				
Air flow measurement				
Pitot tube				
Tubing				
0-0.25" gage				
0-0.50" gage				
2"-diameter x 5' long PVC				
4"-diameter x 8' long PVC				
Flexible connectors (Femco)				
1 1/2" x 2"				
1 1/2" x 4"				
2" x 2"				
2" x 4"				
4" Street ell				
2" Street ell				

RESPIRATION TEST

Data sheets				
Helium mixing manifold				
Meters				
Portable pumps (1 CFM)				
Portable pump covers				
Tubing, 3/16"				
Tees				
Clamps				
VW top with 3/16" hose barb				
Regulator, helium				

EXTENDED TEST BLOWER SYSTEM

Air filters				
Air filter elements (spare)				
Blower (and alternate ?)				
Blower enclosure				
Bleed valve (gate valve)				
Misc. pipe fittings				
1 1/2" for regenerative blower				
3/4" for rotary vane blower				
Pressure gage (dial)				
Pressure relief valve (automatic)				
PVC and/or iron pipe fittings				
VW top				
Blower to VW				
Gages, dial type (vacuum & pressure)				
Starter (and alternate ?)				
Thermometer (dial)				

ITEM	NEEDED	NOT NEEDED	IN STOCK	ADD TO STOCK
------	--------	------------	----------	--------------

HEALTH AND SAFETY

Calibration gas				
Draeger kit				
Explosimeter				
Eye wash				
First Aid Kit				
Gloves - inner				
Gloves - outer				
Gloves - leather				
Goggles/safety glasses				
Health & safety plan				
Hard hats				
Hnu/TIP/TVHA				
Nuke boots				
Steel toe boots				
Rain gear				
Tyvek suits				

MISCELLANEOUS

Camera				
Extension cords				
Federal Express Forms				
Field Clipboard				
Film				
Flagging tape				
Generator				
Helium				
Light, clamp-on				
List of contacts				
Locks				
Paper towels				
Pens and Markers				
Pick axe				
Scissors				
Shovel				
SUMMA Canister adaptor				
Tape - Duct				
Tape - Clear				
Tool kit				

APPENDIX E
PROJECT MANAGEMENT PLAN

**PROJECT MANAGEMENT PLAN
AFCEE BIOVENTING PILOT TESTS**

April 1992

Updated January 1993

Prepared by:

**Engineering-Science, Inc.
1700 Broadway, Suite 900
Denver, Colorado 80290**

CONTENTS

	<u>Page</u>
1	Project Description 1-1
2	Tasks and Deliverables 2-1
2.1	Task Descriptions..... 2-1
2.1.1	Program Management Tasks 2-1
2.1.2	Site Specific Tasks..... 2-2
2.2	Project Deliverables 2-5
3	Organization and Staffing..... 3-1
3.1	Organizational Structure..... 3-1
3.2	Staff Responsibilities 3-1
4	Project Schedule, Approach and Labor Allocations 4-1
4.1	Schedule..... 4-1
4.2	Approach 4-1
5	Procedures and Controls..... 5-1
5.1	Project Communications..... 5-1
5.2	Equipment and Material Procurement 5-13
5.3	Maintenance of Project Documents..... 5-13
5.4	Cost and Schedule Controls 5-13
5.4.1	Cost Control..... 5-13
5.4.2	Schedule Controls 5-17

Appendices:

- Appendix A - Sample Test Work Plan/Sample Interim Test Results Report
- Appendix B - Generic Health and Safety Plan
- Appendix C - Quality Assurance Plan
- Appendix D - Field Sampling Plan
- Appendix E - ES Addendum to Technical Protocol
- Appendix F - Initial Base Meeting Checklist
- Appendix G - Extended Testing Results Form
- Appendix H - Generic O&M Manual for Extended Testing System

TABLES

<u>No.</u>	<u>Title</u>	<u>Page</u>
5.1	Points of Contact.....	5-2
5.2	Central Files Index.....	5-14
5.3	Project Cost Codes.....	5-18

CONTENTS (Continued)

FIGURES

No.	Title	Page
3.1	Organization Chart	3-2
4.1	Program Schedule	4-2
4.2	AFCEE Bioventing Accelerated Schedule	4-3
4.3	Typical Pilot Test Schedule and Labor Allocations	4-4

SECTION 1

PROJECT DESCRIPTION

On 20 April 1992, Engineering-Science, Inc. (ES) was awarded a task order by the Air Force Center for Environmental Excellence (AFCEE) Brooks AFB, TX (Contract F33615-90-D-4014, Order 14) to conduct bioventing pilot tests on 23 Air Force bases (35 individual sites) across the United States. On 22 December 1992 this contract was modified to bring the total number of bases to 38 (110 sites). The purpose of these tests is to determine the feasibility of using the bioventing method for soil remediation in a variety of soil types, contaminant concentrations and climatic conditions, and to document the performance of pilot systems over a one year test period.

Bioventing is a simple technology which uses mechanical soil venting to increase soil gas oxygen levels and promote the natural biodegradation of contaminants. Although this technology is most often applied for fuel hydrocarbons, it may also be effective in biodegrading and volatilizing chlorinated solvents. Bioventing can be accomplished by either injecting atmospheric air into the soil or by extracting soil gas and stimulating the influx of atmospheric air and oxygen-rich soil gas from clean soils. The progress of bioventing is monitored by measuring the biological uptake of oxygen and production of carbon dioxide in the soil gas.

A 100-page pilot test protocol document was recently developed by Battelle Laboratories and Engineering-Science, Inc for AFCEE. This testing protocol will serve as the standard test plan for conducting the pilot tests. Additional details on these procedures and soil and soil gas sampling methods are included in Appendixes D and E. Standardized pilot testing procedures and the small blower system that will be installed on each site will simplify project execution and produce a safe, high-quality venting unit.

ES Denver will provide the primary management and personnel resources to accomplish this project. Other ES offices with personnel trained in bioventing test methods will be put in charge of completing tests on bases in their region. A more complete description of how ES resources will be integrated to perform this work is contained in Section 3.

SECTION 2

TASKS AND DELIVERABLES

AFCEE and ES have developed a series of tasks and deliverables to efficiently perform the pilot tests and to document test results. These well-defined tasks will insure a uniform approach from site to site and allow costs to be carefully tracked as the work is performed.

2.1 TASK DESCRIPTIONS

The following tasks have been developed to fulfill the requirements of the AFCEE statement of work in a timely and cost efficient manner. The tasks have been divided into two primary categories, Program Management Tasks and Base Specific Pilot Testing Tasks. A brief description of ES and Air Force responsibilities under each task are provided below.

2.1.1 Program Management Tasks

Task 1.1 - Program Mobilization

This task includes preparation of project initiation documents, such as this project management plan. Pricing and ordering of test equipment and materials. Setting up files and a cost accounting structure. Other deliverables under the Program Mobilization Task include:

Program Schedule

Developing a schedule for completing the pilot tests on 110 sites within a two year period. This was provided to AFCEE on 5 May 1992 and is updated quarterly.

Developing a sample format for a site specific pilot test work plan. This format will provide site specific maps and vent well descriptions but will primarily reference the 100-page protocol document. A sample test work plan is included in Appendix A and was approved by AFCEE on 6 May 1992. A generic health and safety plan will be developed for performing bioventing pilot tests (Appendix B). A base specific health and safety addenda will be developed for each base. Although not specifically required in the SOW, a sampling and analysis plan (SAP) has been developed to promote quality, and uniformity and found in Appendix D.

Project Initiation Meeting

Approximately 15 days after contract award, a meeting was held between AFCEE technical program managers and the ES project manager. This meeting was completed on 6 May 1992 and included discussions on the statement of work,

program schedule, regulatory strategies and the format of deliverables. The results of this meeting have been incorporated into this updated PMP.

Task 1.2 - Prepare Drilling Subcontracts

Several drilling subcontracts are anticipated to complete this work. ES will prepare these contracts using several generic vent well and vapor monitoring point layouts and attempt to get a discounted price for multiple bases. Local ES offices will assist in the subcontracting effort since they are knowledgeable of experienced and cost effective drilling firms in their region.

Task 1.3 - Management of AFCESA Soil Samples

A separate bioventing test contract has been issued by the Air Force Civil Engineering Service Agency (AFCESA) to Battelle Laboratories. Soil samples and soil gas samples collected by Battelle will be sent to the ES Berkeley Lab for analysis. ES Denver will track these samples and insure that a copy of all results are returned to Battelle.

Task 1.4 - Monthly Cost and Progress Reporting to AFCEE

This task will be the primary responsibility of ES San Antonio office with technical and cost input from ES Denver. Monthly reports are due to AFCEE on the 20th of each month and will summarize the previous month's activities.

Task 1.5 - Special Notifications

Special notifications are intended to provide AFCEE with immediate written notification of hazardous conditions or safety problems encountered during testing.

Task 1.6 - Final Technical Report and Presentation Package

A final technical report will be produced after all pilot tests have been performed. The report will summarize the results of the tests by providing analytical results, in situ respiration data and air permeability data for each site. Single-line as-built drawings of vent well installations and the blower configuration for each site will also be included. A presentation package including photos and 35-mm slides of each site and viewgraphs will be prepared to present the overall results of these tests.

2.1.2 Site Specific Tasks

The following tasks will generally be performed in preparing for and during pilot tests at each site. On bases with multiple sites, many of the tasks will be performed once for each base. For example, only one test work plan and only one interim report on test results will be prepared for each base. These reports will be divided into site-specific sections. The following site specific tasks have been identified:

Task 01 Initial Base Meeting

A one-day meeting will be held at each base to familiarize the ES team manager or site manager with the candidate test sites and to coordinate base support requirements. A checklist will be completed during each initial meeting to insure important site information is gathered and a tentative layout of the test wells is

determined. Other topics such as regulatory requirements, power requirements, base security and schedule will be discussed. The findings of this meeting will be translated into the site specific test work plan.

Task 02 Develop Base Specific Test Work Plan/Health and Safety Plan

A base specific test work plan will be prepared and submitted to AFCEE at least 30 days prior to initiating field work on each base. AFCEE is required to provide ES with available site investigation data on each site at least 60 days prior to initiating field work. ES should have approximately 30 days to complete the base specific documents. Due to the standardization of these documents, they can be produced much faster when required. The test work plan will consist of a brief letter report which will describe each site, the proposed location of the vent well and vapor monitoring points, proposed soil sampling locations and a schedule for completing the initial pilot test. An example test work plan is provided in Appendix A. A generic health and safety plan has been produced for bioventing pilot tests and is provided in Appendix B. The plan will be customized for each base by including an addenda with site specific data. Every ES person and drilling subcontractor who will be working on a site must read and sign the health and safety report before they can work on the site. The test work plan will be used as an addendum to the 100-page test protocol document which will often be submitted for regulatory approval.

Task 03 Regulatory Permit Applications

Although the Air Force will take the lead in obtaining regulatory approval for pilot testing at each base, ES will assist the Air Force by completing air emission permits, if they are required. Past ES bioventing pilot tests have required minimal permitting due to the minor air emissions involved. Whenever possible, local drillers will be asked to assist in the preparation of drilling and well permits as a part of their subcontracts. AFCEE has also requested that ES determine the appropriate well abandonment procedures for vent wells on each base. Once the test wells are sited, the base point of contact will prepare an Air Force digging permit to locate and mark all underground utilities in the test area.

Task 04 Construct Pilot Test System and Perform Air Permeability and In Situ Respiration Testing

This task will be performed in one or two phases depending on the availability of test equipment and drilling schedules. A single mobilization is desired which begins with the drilling and construction of a central vent well and several vapor monitoring points and then moves directly into air permeability and in situ respiration testing. In some instances it may be more cost effective for an ES geologist and subcontracted driller to install the wells on several sites and have the test team return to perform the tests. The drilling/testing sequence for each base will be a base-specific decision.

A complete description of well construction methods and test procedures is found in the 100-page test protocol. Briefly this task will include:

- An initial soil gas survey or exploratory borings to find the center of the fuel spill if site characterization data is incomplete.
- The installation of a central vent well and four vapor monitoring points, including an uncontaminated background well. Three soil samples and three soil gas samples will be collected from each site for analysis at the ES Berkeley Lab. (See details in Appendix E)
- Initial oxygen and carbon dioxide soil gas readings.
- An air permeability test to determine the feasibility of moving sufficient oxygen into the contaminated soil.
- An in situ respiration test to measure the rate of oxygen uptake of fuel degrading microorganisms.
- If initial test results are positive, the installation of a small blower unit to provide soil ventilation over a one year extended testing period. Test results will be immediately phoned or "faxed" to the project manager who will then relay results to the AFCEE TPM. Verbal approval to proceed with the small blower installation will be provided to the field team while they are still on site. Operation and maintenance procedures for the blower will be explained to the base P.O.C. and an O&M Manual and checklist provided.

Task 05 Interim Test Results Report

A letter report will be prepared and delivered to the AFCEE TPM within 45 days of the test completion. The letter report will include a discussion of test results, any exceptions to the standard protocol, a single line "as built" drawing of the test wells and blower configuration, blower specifications, and a summary lab analysis results table. Air permeability test results will be provided in the Hyperventilate software format and respiration results will be provided on an Excel spreadsheet. At the end of the project, a computer disk will be provided which contains test data for each base.

Task 06 Extended Testing

The small blower will be installed on the site and continue to ventilate the soil for approximately one year. During this year of operation, ES will perform two in situ respiration tests at each site to determine the rate of biological degradation. The first test will occur approximately six months after installation or when soil temperatures are expected to be significantly warmer or colder than the initial test. The last respiration test will take place after approximately one year of operation.

Three soil and three soil gas samples will be gathered at the same time as the final respiration test. These samples will be analyzed by the ES Berkeley Lab. The purpose of this sampling is to determine the actual fuel removed after one year and how the ratio of TPH to BTEX has been altered. Whenever possible, a Minuteman or other ES operated drill rig will be used to collect the final soil samples. For depths exceeding 30 feet, a driller will be used.

Task 07 System Repairs

Basic system checks and maintenance such as filter changes will be a base responsibility. Consultations with base personnel on system problems will be charged to this task. However, if a motor or blower fails, ES will be responsible for replacing the blower or motor. Since these blowers will carry an unconditional one-year warranty, a local ES technician will order a replacement blower and return the broken item to the manufacturer. (If possible the base point of contact will be asked to ship the blower to the nearest ES office and also asked to replace it with a new unit we send them. If the base cannot or will not provide this support, the ES technician will drive to the site and make the switch.) Our experience with these simple units is that they are very reliable.

2.2 PROJECT DELIVERABLES

The following deliverables have been specified for this project:

<u>Item</u>	<u>Frequency</u>	<u>1st Draft</u>	<u>Copies</u>
1. Program Schedule	quarterly	5 May 92	5
2. Test Work Plan/ Health & Safety Plan	23	5 May 92	10
3. Interim Letter Repts/ Test Results	23	45 days after each test	10
4. Final Letter Report/ Technical Report	once	60 days after last test	10
5. Special Notifications	as required	3 days after event	3
6. Presentation Material	once	60 days after last test	3
7. Photos/Slides	once	60 days after last test	
8. Monthly Cost/ Status Reports	monthly	20th of month	2
9. Hyperventilate/ Excel Data Disks	1 file/ site	15 days after each test	2

2.2.1 Deliverables Flow Chart

Figure 2.1 provides a flow chart showing how deliverables will be produced, reviewed and routed for this project.

**FIGURE 2.1
DELIVERABLES FLOW CHART**

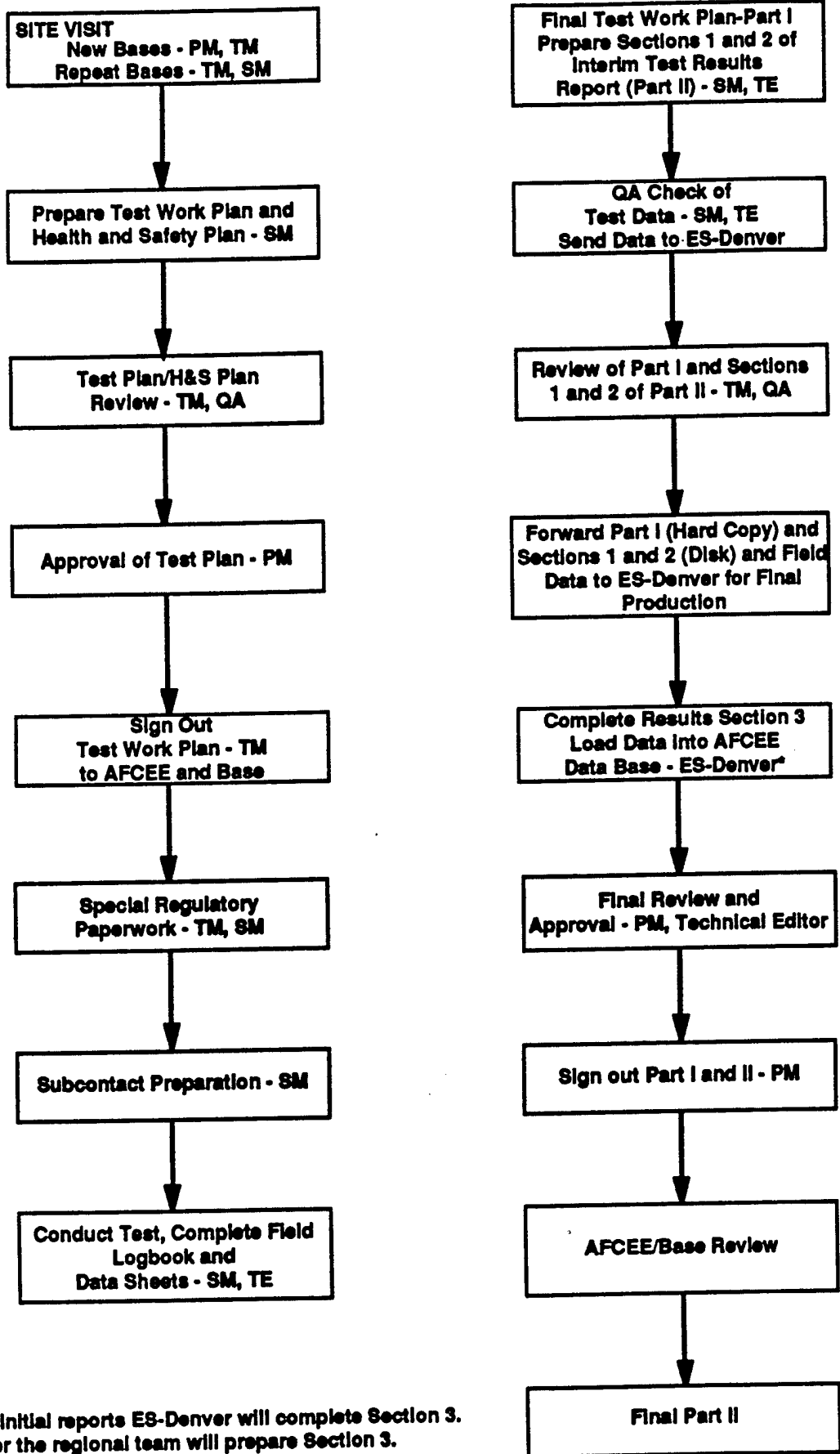

* For initial reports ES-Denver will complete Section 3. Later the regional team will prepare Section 3.

SECTION 3

ORGANIZATION AND STAFFING

3.1 ORGANIZATIONAL STRUCTURE

An organization chart showing key staff positions and lines of authority is provided in Figure 3.1. The organization and staffing illustrated on this chart will be adequate to complete all aspects of the statement of work. This organization has been created to support the Site Manager and Test Engineer in their planning and execution of bioventing pilot tests. The primary responsibility of all staff members is to support the test teams by reducing their administrative burdens and to provide them with the resources to conduct successful pilot tests. Our common goal will be to make technical excellence and customer satisfaction the trademark of every test we perform.

3.2 STAFF RESPONSIBILITIES

Program Sponsor - Mr. Tom Sargeant

Responsible for overall client satisfaction with work performed under this AFCEE contract. Provides corporate resources to ensure a high quality product is provided.

Program Manager - Mr Bob Binovi

Responsible for day-to-day contract management activities and direct liaison with AFCEE officials. Reviews monthly cost and progress reports, prepares and negotiates contract modifications, assists the project manager in fulfilling AFCEE contract requirements.

Project Manager - Mr Doug Downey

Overall responsibility for completing the requirements of the statement of work. Organizes personnel and resources to accomplish pilot testing on approximately 110 Air Force sites. Supervises and trains staff members. Provides technical direction and ensures quality products are produced. Responsible for the following specific activities under this work order:

FIGURE 3.1
ORGANIZATION CHART

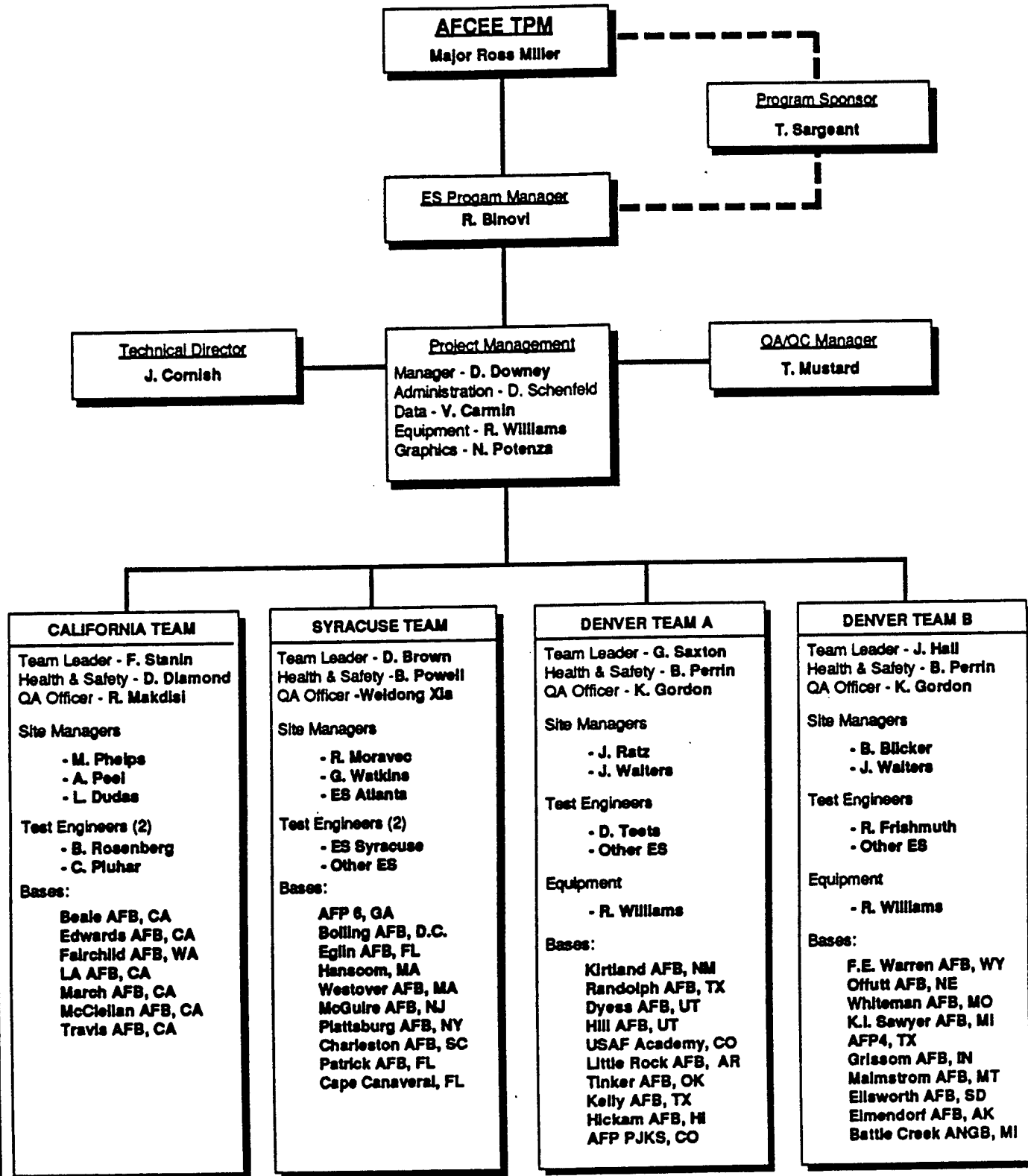

- Develops the organizational approach to complete the work.
- Trains staff in bioventing procedures.
- Develops sample test work plans and interim test reports for use by other staff members.
- Attends initial base meetings to determine a pilot test approach for each site and to establish working relationships with base personnel.
- Provides a final review and approval of site specific work plans.
- Reviews/approves monthly invoices before forwarding them to ES-San Antonio for final preparation.
- Evaluates and approves test data. Oversight of data transition into test results.
- Final approval and signs out all interim test result reports.
- Prepares final data report on 110 site bioventing results.

Project Administrator -

The project administrator assists the project manager in areas of cost control, laboratory results accounting, scheduling and status reporting. Specific responsibilities include:

- Assists in the preparation of monthly invoices.
- Review of weekly cost summaries for potential errors.
- Tracking of laboratory results and invoices to insure analytical data is complete and invoices are paid promptly after data is received.
- Tracking and scheduling of project deliverables (work plans and interim test results) to insure proper QA/QC is performed and deliverables are produced in a timely manner.
- Prepares a written base-by-base update each month and provides it to the project manager.

Graphics Manager - Ms. Nancy Potenza

- Contacts site managers and obtains at least six good photos and negatives for each test site completed.
- Places photos and negatives in the base specific file under Interim Test Results Report.
- Prepares one specialty slide (5 copies) for each site and provides three copies to the AFCEE TPM (Major Miller).
- Assist the project manager in preparation of final presentation package and special project graphics as required.

Data Manager - Ms. Vicki Carmin

- Receives test data from team managers and completes calculations for air permeability and in situ respiration tests. Prepares graphics and tables for interim test results reports.
- Builds data base for final data base report to AFCEE.
- Receives laboratory data for soil and soil gas analysis and completes summary tables for interim test results report.

Team Managers - Ms Gail Saxton, Mr. John Hall, Mr. Dave Brown, Mr. Fred Stanin

Assists the Project Manager in day to day organization of execution of bioventing tests with the following specific responsibilities:

- Organizes teams of site managers, test engineers and equipment to accomplish bioventing tests on assigned bases.
- Conducts initial site visits on bases where regulatory briefings are not required and base officials are familiar with bioventing tests.
- Assists site manager in developing test work plans for each new base or amended work plans for bases which have previously hosted bioventing tests.
- Assists the project manager by providing technical support to AFCEE and base officials in regulatory negotiations and permitting, if required.
- Insures that technical problems are resolved by contacting a qualified technical resource.
- Assists site managers in obtaining base support for electrical supply, digging permits, and long-term maintenance of installed systems.
- Assists site managers in the preparation of Interim Test Results Reports and insures high-quality test data is provided to ES-Denver.
- Responsible for reviewing weekly job cost summaries and for keeping labor and ODCs within assigned budgets for each base.
- Signs subcontractor, test equipment, materials and supplies invoices and insures they are assigned to the proper cost code.
- Prepares a brief monthly written summary of activities accomplished on each base (one paragraph/base) and provides a copy to the program manager on or before the 3rd day of each month.

Technical Director - Mr John Cornish

Mr John Cornish will provide technical reviews of the sample test work plan, interim test results report and advise on proper blower installation methods.

Quality Assurance Manager - Mr Tim Mustard

Responsible for insuring that corporate QA/QC procedures are followed and that the quality of products delivered to AFCEE meet or exceeds all standards. Duties will include an audit of all field and office procedures to insure they conform to the project specific Quality Assurance Plan.

Quality Assurance Officers - (one per region)

Assists regional team managers in maintaining a high standard of deliverable quality by reviewing documents, conducting file audits, and other QA duties.

Health and Safety Officers - (one per region)

Assists site managers in the development of the generic health and safety plan for bioventing pilot tests and the addition of site specific modifications. Conduct one field audit per region during testing to insure that health and safety procedures are being followed.

Site Managers

Responsible for performing the pilot test at a specific site within a specific budget and timeframe. Responsibilities include:

- Completing the test work plan and site specific health and safety plan and preparing it for AFCEE and regulatory review.
- Finalizing drilling and testing schedules and coordinating support from base personnel and local ES offices.
- Arranging drilling subcontracts when required.
- Organizing equipment and supplies for field testing.
- Supervision of drilling and well installations.
- Conducting the pilot test in accordance with the protocol and test work plan.
- FAX initial results for project manager and AFCEE review and participate in technical decision to install blower for extended testing.
- Install blower for extended testing and prepare single line as-built drawings for test results report.
- Training base personnel in basic system checks and maintenance.
- Preparation of interim test results report Sections 1 and 2, and provide quality data for Section 3.
- Make monthly telephone contact with each assigned base to insure systems are operating properly.
- Conducts final respiration test and collects soil samples from each site after one-year of blower operation.

Test Engineer

Responsible for assisting the site manager in all aspects of his/her work with special emphasis on:

- Preparation of equipment and materials for all aspects of pilot testing.
- Conducting six-month in situ respiration tests.
- Checking of test data before leaving the site to insure it is complete and accurate.
- Installation of blower for extended testing.
- Responding to base maintenance questions and correction of blower problems that occur during extended testing.
- One test engineer in each region will also serve as the test equipment and materials manager and keep an accurate inventory of all test equipment purchased for this project and insure that rental charges are applied to appropriate cost codes (see Section 5.4).

SECTION 4

PROJECT SCHEDULE, APPROACH AND LABOR ALLOCATIONS

This section describes the schedule and general approach that has been developed to complete all aspects of pilot testing and extended bioventing at a typical Air Force installation.

4.1 SCHEDULE

Three schedules have been developed to more completely describe the work under this contract. A general program schedule (Figure 4.1) is provided to describe the overall program milestones and deliverables. Figure 4.2 describes an updated schedule for completing each of the 38 bases assigned under this contract. Because the sequence of testing for all 38 bases cannot be predicted and will be subject to change due to regulatory delays, the schedule will be finalized in 90 day segments. Figure 4.3 provides a more detailed schedule of the preparations and events required to complete a pilot test at a typical base. Labor allocated for each major task is found in Section 5.4. Since test teams will be working different phases of several sites, the total time to complete 110 sites will depend on the degree of overlap.

4.2 APPROACH

The following narrative is intended to provide a general approach for planning and executing each pilot test and corresponds to the site specific tasks described in Section 2.1.2 and the events shown in Figure 4.3. Although the approach will be altered to meet site specific requirements, major changes are not anticipated and should only occur with the approval of the project manager.

Review Site Data

AFCEE and the bases will provide available site characterization data for each site selected for the bioventing pilot tests. If additional data are required, the designated site manager will contact the base point of contact and discuss the data requirement and request written documents if needed to develop the test work plan. Labor Allocation: Hours for data review will be assigned to the Test Work Plan (Task 02) for each base.

Initial Base Meeting (Task 01)

A one-day meeting will be held at each base to familiarize the ES project manager (PM) or team manager, and site manager (SM) with the candidate test

**FIGURE 4.1
PROGRAM SCHEDULE**

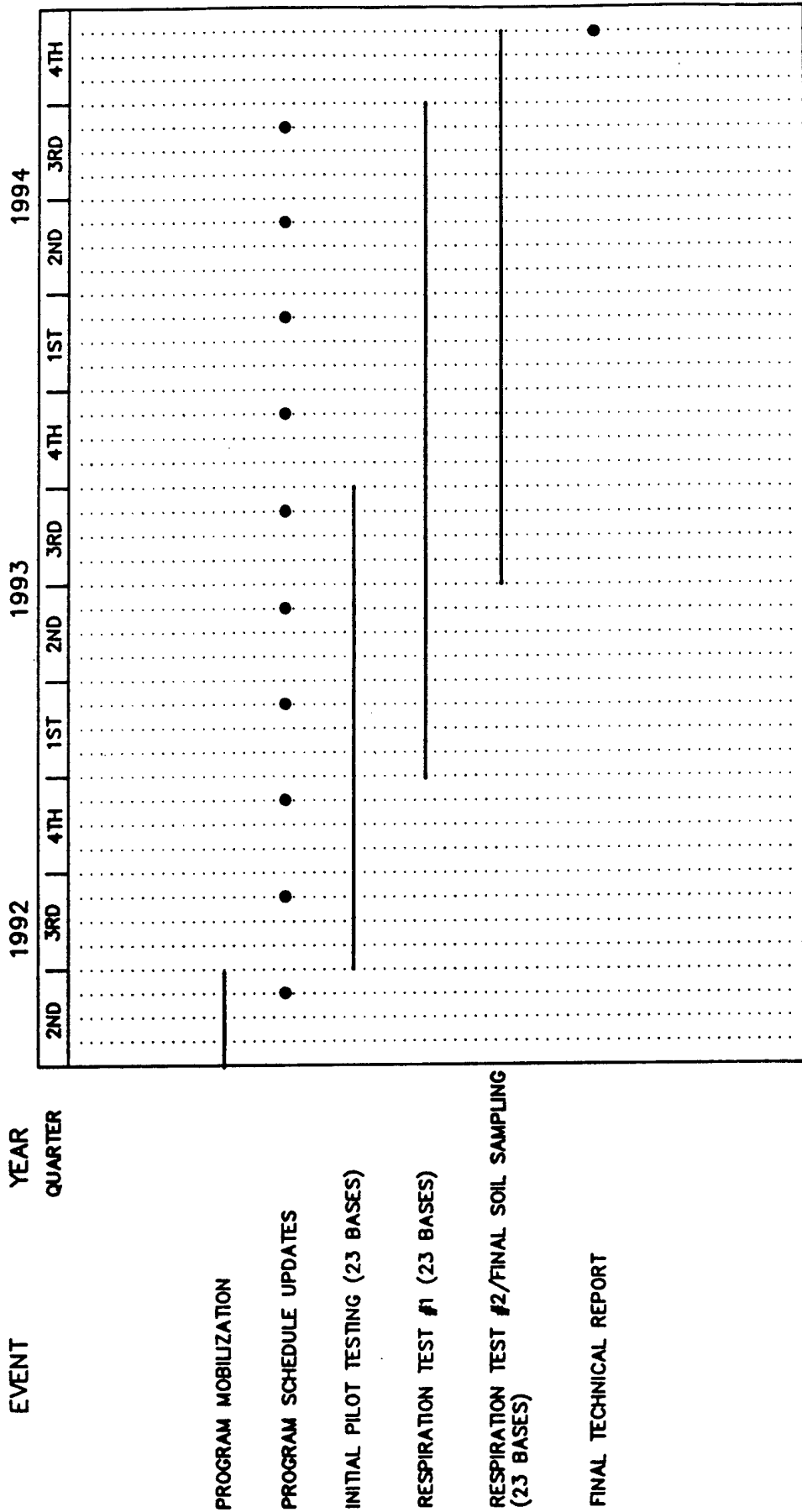

**FIGURE 4.3
TYPICAL PILOT TEST SCHEDULE**

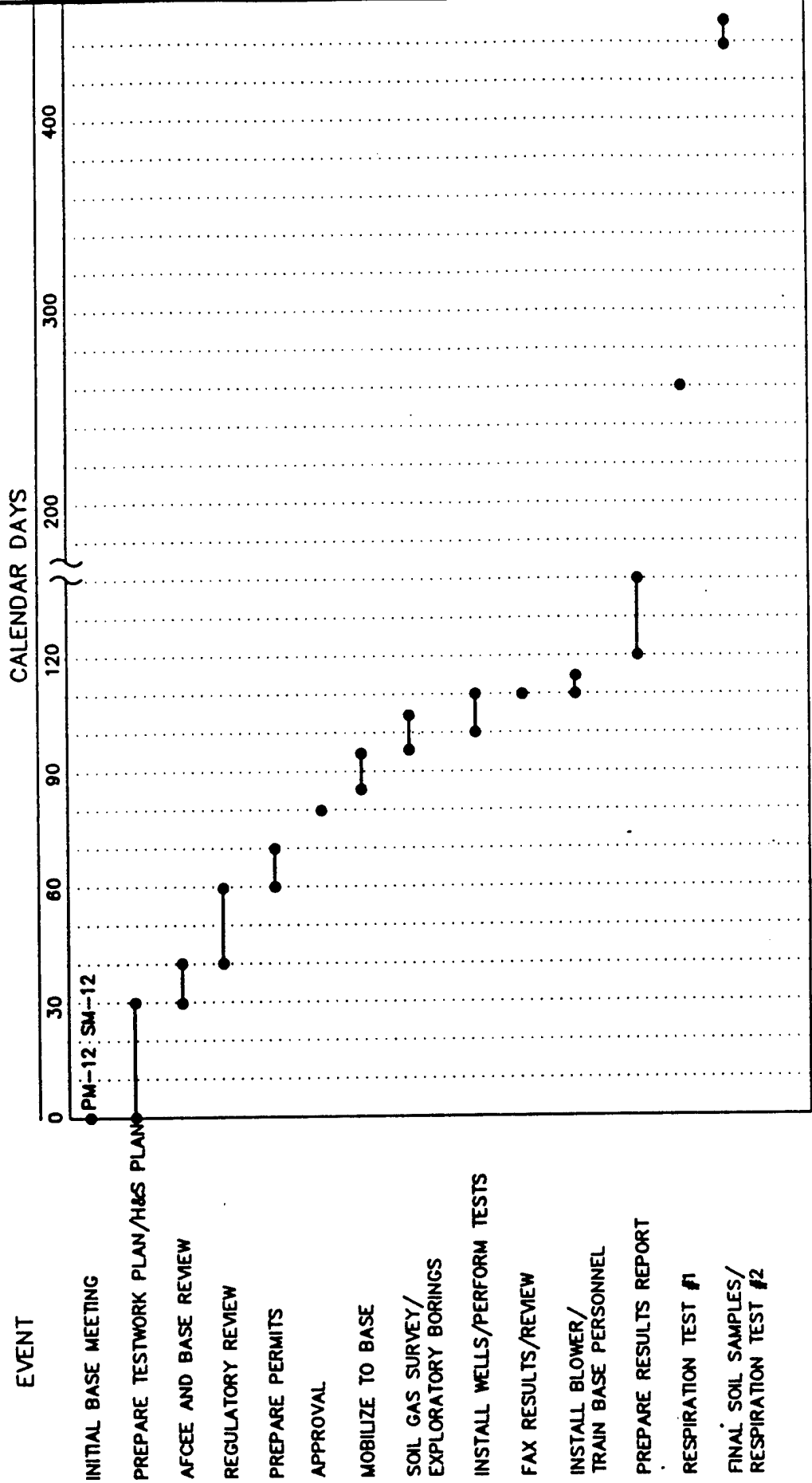

FIC
AFCEE BIOVI
STATUS

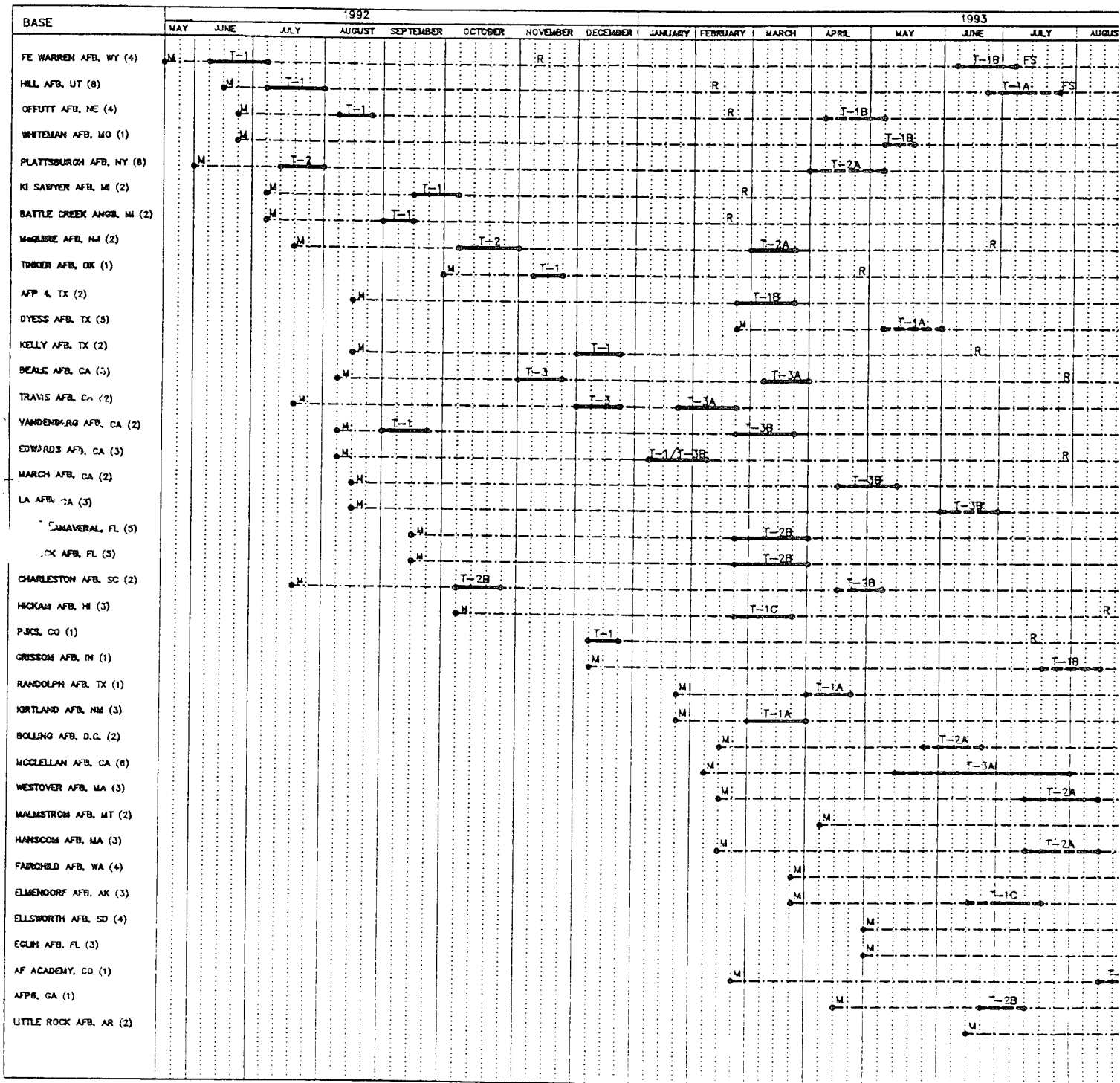

sites and to coordinate base support requirements. During the initial year of the project the PM will attend these meetings. As the experience of the team manager and site managers increases they may attend these meetings for the PM. A checklist will be completed during each initial base meeting (Appendix G) to insure important site information is gathered and a tentative layout of the test wells is determined. Other topics such as regulatory requirements, base security and schedule will be discussed. The findings of this meeting will be translated into the site specific test work plan. Labor Allocation for Task 01: SM - 12 hrs, PM/TM-12 hrs.

Test Work Plan/Health and Safety Plan (Task 02)

A base specific test work plan will be prepared and submitted to AFCEE and the base at least 30 days prior to initiating field work on each base. AFCEE is required to provide ES with available site investigation data on each site at least 60 days prior to initiating field work. ES should have approximately 30 days to complete the base specific documents. Due to the standardization of these documents, they should be easy to prepare. The test work plan will consist of a brief letter report which will describe each site, the proposed location of the vent well and vapor monitoring points, proposed soil sampling locations and a schedule for completing the initial pilot test. The site manager will have primary responsibility for completing this document with assistance from the test engineer (TE). The team manager will sign out all test work plans following a technical review by the project manager. An example test work plan is provided in Appendix A.

The general health and safety plan for bioventing activities will be customized for each base by specific addenda with information on site specific hazards and local emergency phone numbers and hospital routes. An example health and safety plan is provided in Appendix B. Every site worker including subcontractor will read and sign the cover sheet of the health and safety plan before entering the field.

The test work plan and health and safety (H&S) plan will be used as an addendum to the 100-page test protocol document. A first draft will be submitted to AFCEE and the base for an initial review and after their changes are incorporated a final draft submitted for regulatory approval when required. It is likely that some states will approve pilot tests within a few weeks while others take much longer. Because it is difficult to schedule a series of pilot tests without consistent regulatory approval, we will try to obtain regulatory approvals for all sites on a base to reduce multiple trips to the same area. Labor Allocation for Task 02: SM-50 hrs, TE-20 hrs, TM-10 hrs, PM-2 hrs

Regulatory Permit Applications (Task 03)

The strategy for regulatory approval will be developed during the initial base meeting. Each base and the AFCEE TPM will be responsible for obtaining regulatory approval for pilot testing at each base. ES will assist the Air Force by providing technical support but will not negotiate with regulators. The PM and TM will provide this support as required. Past ES bioventing pilot tests have required minimal permitting due to the minor air emissions involved. Drillers will be asked to assist in the preparation of drilling and well permits as a part of their

subcontracts. Once a test well layout is provided in the draft test work plan, base officials will check underground utilities and obtain the necessary digging permit. Base AFCEE has also requested that ES determine the appropriate well abandonment procedures for vent wells on each base. Labor Allocation for Task 03: SM-24 hrs, TE-6 hrs, PM/TM-2 hrs

Construct Pilot Test System and Perform Air Permeability and In Situ Respiration Testing (Task 04).

Approval to proceed with a pilot test will be contingent upon AFCEE, base, and local regulatory approval of the Test Work Plan. Once approval is received from AFCEE, and the base ES will finalize the pilot test schedule and begin to mobilize for the test. Mobilization will include final drilling subcontract arrangements, test equipment preparation, insuring base support assignments such as electrical power supply and digging permits have been completed, and driving or flying to the site.

This task will be performed in one or two phases depending on the availability of test equipment and drilling schedules. A single mobilization is desired which begins with the drilling and construction of a central vent well and several vapor monitoring points and then moves directly into air permeability and in situ respiration testing. In some instances it may be more cost effective for an ES geologist and subcontracted driller to install the wells on several sites and have the test team follow several days behind performing the tests. The drilling/testing sequence for each base and the mix of ES Denver and other ES office personnel will be a base-specific decision.

A complete description of well construction methods and test procedures is found in the 100-page test protocol. Briefly this task will include:

- An initial soil gas survey or exploratory borings to find the center of the fuel spill when site characterization data is incomplete.
- The installation of a central vent well and four vapor monitoring points, including an uncontaminated background well. Three soil samples and three soil gas samples will be collected from each site using procedures outlined in Appendix D and sent for analysis at the ES Berkeley Lab and Air Toxics Ltd. (ES Berkeley will provide a base-by-base summary of current test results to the team manager within 30 days of the receipt.)
- Initial oxygen and carbon dioxide soil gas readings will be taken from all wells.
- A one day air permeability test will be performed to determine the feasibility of moving sufficient oxygen into the contaminated soil.
- A three to four day in situ respiration test will be conducted to measure the rate of oxygen uptake of fuel degrading microorganisms.
- Test results will be immediately "faxed" to the team manager or project manager who will relay results to the AFCEE TPM. If initial test results are positive, a small blower unit will be installed on the site to provide soil ventilation over a one year extended testing period. Verbal approval to

proceed with the small blower installation will be provided to the field team while they are still on site.

Labor Allocation for Mobilization, Drilling and Testing Task 04:
SM-130 hrs, TE-130 hrs, TM-4 hrs

Prepare Interim Test Results Report (Task 05)

Within 30 days of completing the initial test, the site manager and test engineer will prepare Sections 1 and 2 of a draft Interim Test Results Report and a final Test Work Plan. Examples of these reports are found in Appendix A. Within 15 days of completing initial pilot tests the team manager will forward a copy of all field notes and a clean, quality-controlled, copy of data from the air permeability, oxygen influence and *in situ* respiration tests. ES Denver will enter all data into an AFCEE master data base and complete an analysis of the data. Initially, ES Denver will complete Section 3 of the Interim Test Results Report and produce the consolidated report. After completing several sites, and gaining confidence in data analysis, regional team managers will be responsible for completing the entire report. ES Denver will continue to receive field data for each site and the project manager will continue to provide final review and signature of all Interim Test Results Reports.

Extended Testing (Task 06)

The small blower will be installed on the site and continue to ventilate the soil for approximately one year. During this year of operation, ES will perform two *in situ* respiration tests at each site to determine the rate of biological degradation. The results of this test will be provided to ES Denver using the form provided in Appendix F.

The first test will occur approximately six months after installation or when soil temperatures are expected to be significantly warmer or colder than the initial test. A test engineer will conduct the first respiration test. This test will require only one person and will generally last no more than 3 days. Several tests will be scheduled in the same geographic region and the test engineer will generally drive from site to site. Labor Allocation Per Site for First Respiration Test: TE-40 hrs, SM-12 hrs, PM-2 hrs

The last respiration test will take place after approximately one year of operation. In addition to the respiration test, three soil and three soil gas samples will be gathered from near the original sampling locations. These samples will be analyzed by the ES Berkeley Lab and Air Toxics Ltd. The purpose of this sampling is to estimate the actual fuel removed after one year and how the ratio of TPH to BTEX has been altered. Whenever possible, a Minuteman® or other small, ES operated drill rig will be used to collect the final soil samples. For depths exceeding 30 feet, a driller may be required. Labor Allocation for Final Respiration Test and Soil Sampling : SM-60 hrs, TE-80 hrs, TM-4 hrs

System Repairs (Task 07)

Basic system checks and maintenance such as filter changes will be a base responsibility. Consultations with base personnel on system problems will be charged to this task. However, if a motor or blower fails, ES will be responsible for replacing the blower or motor. Since these blowers will carry an unconditional one-year warranty, a local ES technician will order a replacement blower and return the broken item to the manufacturer. (If possible the base point of contact will be asked to ship the blower to the nearest ES office and also asked to replace it with a new unit we send them. If the base cannot or will not provide this support, the ES technician will drive to the site and make the switch.) Our experience with these units is that they are very reliable. Labor Allocation for Task 07: TE-20 hrs/base, SM-2 hr base.

SECTION 5

PROCEDURES AND CONTROLS

This section describes the standard procedures which will be used to efficiently complete the assigned work and the project controls which will be implemented to track costs and organize project documents. This section has four subsections:

- 5.1 PROJECT COMMUNICATIONS**
- 5.2 EQUIPMENT AND MATERIAL PROCUREMENT**
- 5.3 MAINTENANCE OF PROJECT RECORDS**
- 5.4 COST AND SCHEDULE CONTROLS**

5.1 PROJECT COMMUNICATIONS

All written communication with AFCEE or base officials will be signed by the project manager or team manager. Any person having verbal communication with AFCEE will prepare a record of telephone conversations and provide a copy to the project manager. Site managers are authorized to verbally communicate with base personnel while arranging pilot test support and during the pilot test. If the conversation involves decisions which will impact budget or test completion dates, they will be recorded in writing and provided to the team manager as soon as practical. Copies of phone conversations will be kept in appropriate program of base-specific files. If parties to the conversations request copies, they will be sent. All correspondence to the Air Force should be addressed to the technical project manager, Major Ross Miller, or his designated representatives. A listing of key ES, AFCEE and base points of contact is included as Table 5.1.

ES will only communicate with regulatory agencies after the Air Force has made initial contacts and only with Air Force permission. The Air Force will conduct all negotiations with regulatory agencies concerning the pilot test. ES will obtain drilling and well permits and will assist the Air Force in filling our air emission permits if required. The document originator will log all correspondence and transmittals with the proper file designation, (in the upper right hand corner) per the filing system (Section 5.3).

All draft work plans sent to AFCEE or the base will include a cover letter with the team manager's signature. All Final Work Plans and Interim Test Results reports will be reviewed by, and include a cover letter signed by, the project manager. The number of reports required for each deliverable are described in

TABLE 5.1
POINTS OF CONTACT

Engineering-Science Inc.

Program Manager:

Mr Robert Binovi
ES Austin
San Antonio, TX

Project Manager:

Mr Doug Downey
1700 Broadway, Suite 900
Denver, CO 80290
(303) 831-8100

Deputy Project Manager:

Ms Gail Saxton
1700 Broadway, Suite 900
Denver CO 20290
(303) 831-8100

AFCEE

Technical Program Manager:

Major Ross N. Miller
AFCEE/ESR
Brooks AFB, TX 78235-5000
1 (800) 821-4528 ext.282

Technical Program Manager:

Mr Jim Williams
AFCEE/ESR
Brooks AFB, TX 78235-5000
1 (800) 821-4528 ext.282

Technical Program Manager:

Mr Sam Taffinder
AFCEE/EST Building 624W
Brooks AFB, TX 78235-5000
1 (800) 821-4528 ext.230
FAX (512) 536-9026

Contracting Officer:

Mr William M. Watts
Human System Division/PK
Brooks AFB, TX 78235-5000
(512) 536-9386

AFCEE POINTS OF CONTACT

SAM TAFFINDER
AFCEE/EST
2504 D Drive, Suite 3
Brooks AFB, TX 78235-5103
DSN 240-4366
COM 210-536-4366
FAX 210-536-4330

JERRY HANSEN
AFCEE/EST
2504 D Drive, Suite 3
Brooks AFB TX 78235-5103
DSN 240-4353
COM 210-536-4353
FAX 210-536-4330

JIM WILLIAMS
AFCEE/ESCM
8001 Inner Circle Dr., Suite 2
Brooks AFB TX 78235-5328
DSN 240-5246
COM 210-536-5246
FAX 210-536-9026

CAPT CHUNG YEN
AFCEE/ESCT
8001 Inner Circle Dr., Suite 2
DSN 240-5241
COM 210-536-5241
FAX 210-536-9026

AF Plant 4, TX
AF Plant 6, GA
AF Plant PJKS, CO
Beale AFB CA
Edwards AFB CA
Ellsworth AFB SD
Little Rock AFB AR
Randolph AFB CA
Travis AFB CA
Vandenberg AFB CA

Air Force Academy CO
Bolling AFB DC
Elmendorf AFB AK
F.E. Warren AFB WY
Hanscom AFB MA
Kelly AFB TX
Los Angeles AFB TX
March AFB CA
Plattsburgh AFB NY
Tinker AFB OK
Westover AFB MA
Whiteman AFB MO

Charleston AFB SC
Eglin AFB FL
Fairchild AFB WA
Hickam AFB HI
Kirtland AFB NM

Cape Canaveral FL
Grissom AFB IN
McGuire AFB NJ
Newark AFB OH
Patrick AFB FL

CHARLES TASS
AFCEE/ESCR
8001 Inner Circle Dr., Suite 2
Brooks AFB TX 78235-5328
DSN 240-4763
COM 210-536-4763
FAX 210-536-9026

GRIFFIN JONES
AFCEE/ESCT
8001 Inner Circle Dr., Suite 2
Brooks AFB TX 78235-5328
DSN 240-5294
COM 210-536-5294
FAX 210-536-9026

PATRICK HAAS
AFCEE/ESRX
8001 Inner Circle Dr., Suite 2
Brooks AFB TX 78235-53258
DSN 240-5239
COM 210-536-5239
FAX 210-536-9026

Battle Creek ANGB MI
K.I. Sawyer AFB MI
Malmstrom AFB MT

Dyes AFB TX
Hill AFB UT
Offutt AFB NE

McClellan AFB CA

BIOVENTING INITIATIVE
SELECTED BASES AND POINTS OF CONTACT (POC)
FOR AFCEE AND ES

ARI FORCE ACADEMY (USAFA)
POC: Martha Shelby
HQ USAF/CEV
8120 Edgerton Dr., Suite 40
Colorado Springs CO 80840-2400
DSN 259-4483
COM 719-472-4483

AFCEE POC: Jerry Hansen

AF PLANT 4, TX (ASC)
POC: Kamel Mardini
ASC/EMVR
2060 3rd Street, Bldg 17
Wright Patterson AFB OH 45433-7203
DSN 785-7716/7717
COM 513-255-7716/7717

AFCEE POC: Sam Taffinder

AF PLANT 6, GA (ASC)
POC: Rita Chan
ASC/EMVR
2060 3rd Street, Bldg 17
Wright Patterson AFB OH 45433-7203
DSN 785-4151/5855
COM 513-255-4151/5855
FAX 513-255-9985

AFCEE POC: Sam Taffinder

AF PLANT PJKS, CO (ASC)
POC: Kamel Mardini
ASC/EMVR
2060 3rd Street, Bldg 17
Wright Patterson AFB OH 45433-7203
DSN 785-7716/7717
COM 513-255-7716/7717

AFCEE POC: Sam Taffinder

BEALE AFB CA (ACC)
POC: Sherri Rolfsness
9 CES/DEV
Beale AFB CA 95903-1708
DSN 368-2642
COM 916-634-2642

AFCEE POC: Sam Taffinder

BOLLING AFB DC (AFDW)
POC: Capt William Phacker, Jr.
1100 ABG/CEV
1 McChord St., Suite 300
Bolling AFB DC 20032-5403
DSN 297-1159/1162
COM 202-767-1159/1162
FX 202-767-1160

AFCEE POC: Jerry Hansen

CAPE CANAVERAL AFS FL (SPACECOM)
POC: Mark A. Kershner
45 CES/CEV
1224 Jupiter St., Bldg 1224
Patrick AFB FL 32925-3343
DSN 467-6157
COM 407-853-6157
FAX 407-853-6255

AFCEE POC: Capt Yen

CHARLESTON AFB SC (AMC)
POC: Sue Davis
437 SPTG/CEV
100 West Stewart St.
Charleston AFB SC 29404-4827
DSN 673-4978
COM 803-566-4978
FAX 803-566-4993

AFCEE POC: Jim Williams

DYESS AFB TX (ACC)
POC: Teresa Clouse
96 CES/DEV
7103 3rd Street
Dyess AFB TX 79607-1670
DSN 461-5667
COM 915-696-5667
FAX 461-2052

AFCEE POC: Griffin Jones

EDWARDS AFB CA (AFMC)
POC: Steve Daneke
6500 SW/DEV
Bldg 1632
Edwards AFB CA 93523-5000
DSN 527-8092
COM 805-277-8092
FAX 527-0818

AFCEE POC: Sam Taffinder

EGLIN AFB FL (AFMC)
POC: Jay Baynes
646 CES/CEVR
501 DeLeon Street, Suite 100
Eglin AFB FL 32542-5101
DSN 872-3324
COM 904-882-3324
FAX 904-882-5290

AFCEE POC: Jim Williams

ELLSWORTH AFB SD (ACC)
POC: Dell Peterson
28 SG/CEVR
2103 Scott Drive
Ellsworth AFB SD 57706-5000
DSN 675-2677
COM 605-385-2677

AFCEE POC: Sam Taffinder

ELMENDORF AFB AK (PACAF)
POC: Karl Russek
3 SPTG/DEV
22040 Maple Street
Elmendorf AFB AK 99506-3240
DSN 317-552-7305
COM 907-552-7305

AFCEE POC: Jerry Hansen

FAIRCHILD AFB WA (ACC)
POC: Tom Smiley
96 SG/CEV
Fairchild AFB WA 99011
DSN 657-2313
COM 509-247-2313
FAX 509-247-2878

AFCEE POC: Jim Williams

F.E. WARREN AFB WY (ACC)
POC: Linda Wobbe
90 CES/CEVR
300 Vesle Drive
F.E. Warren AFB WY 82005-2793
DSN 481-3468/4154
COM 307-775-3468/4154
FAX 481-4153

AFCEE POC: Jerry Hansen

GRISSOM AFB IN (ACC)
BASE POC: Lt Gina Oliver
305 SPTG/DEV
Grissom AFB IN 46971-5000
DSN 928-4576
COM 317-688-4576
FAX

AFCEE POC: Capt Yen

HANSCOM AFB MA (AFMC)
POC: Robert Spelfogel
647 CES/CEV
Hansom AFB MA 01731-5000
DSN 478-4217
COM 617-377-4217

AFCEE POC: Jerry Hansen

HICKAM AFB HI (PACAF)
POC: William Barry
15 CES/DEV
75 H Street
Hickam AFB HI 96853-5233
DSN 315-448-7519
COM 808-449-7519
FAX 808-448-0563

AFCEE POC: Jim Williams

HILL AFB UT (AFMC)
POC: Andrew Gemperline
OO-ALC/EMR
Hill AFB UT 84056-5990
DSN 458-8790/8791/8792
COM 801-777-8790/8791/8792

AFCEE POC: Griffin Jones

KELLY AFB TX (AFMC)
POC: Dennis Guadarrama
SA-ALC/EMR
Kelly AFB TX 78241-5000
DSN 945-3100 ext 253
COM 210-925-3100 ext 253

AFCEE POC: Jerry Hansen

KIRTLAND AFB NM (AFMC)
POC: Harry Davidson
377 ABW/EM
2000 Wyoming Blvd. SE, Suite 5659
Kirtland AFB NM 87117-5659
DSN 246-2773
COM 505-846-2773
FAX 505-846-0403

AFCEE POC: Jim Williams

K.I. SAWYER AFB MI (ACC)
POC: Maeve Morgan
410 CES/CEV
400 C Ave., Suite 100
K.I. Sawyer AFB MI 49843-3200
DSN 472-2342
COM 906-372-2342
FAX 906-372-1504

AFCEE POC: Charles Tass

LITTLE ROCK AFB AR (AMC)
BASE POC: Robert Hood
314 CES/CEV
4001 Thomas Ave
Jacksonville AR 72099-5005
DSN 731-6762
COM (501) 988-6762
FAX (501) 988-3826

AFCEE POC: Sam Taffinder

LOS ANGELES AFB CA (AFMC)
POC: Michael R. Hanna
6592 ABG/CECV
501 N. Aviation Blvd.
El Segundo CA 90245
DSN 833-0874
COM 310-363-0874
FAX 310-640-6857

AFCEE POC: Jerry Hansen

MALMSTROM AFB MT (AMC)
POC: James Hodges
43 CES/CEV
39 78th Street North
Malmstrom AFB MT 59402-7536
DSN 632-7126
COM 406-731-7126
FAX 406-731-7050

AFCEE POC: Charles Tass

MARCH AFB (AMC)
POC: John Sabol
22 SPTG/DEV
5335 4th Street, Suite 100
March AFB CA 92518-1886
DSN 947-2477
COM 714-655-2477
FAX 714-655-5655

AFCEE POC: Jerry Hansen

McCLELLAN AFB CA (AFMC)
POC:

AFCEE POC: Patrick Hass

MCGUIRE AFB NJ (AFMC)
POC: Robert Panebianco
438 SPTG/DEV
McGuire AFB NJ 08641-5005
DSN 440-6166
COM 609-724-6166
FAX 609-723-0592

AFCEE POC: Capt Yen

MICHIGAN ANG BASE (ANG)
POC: Capt Fredrick C. Vollmerhausen
Michigan Air National Guard
Headquarters, 110th TFG
3545 Mustang Ave.
Battle Creek MI 49015-5509
DSN 580-3233
COM 616-969-3233
FAX 616-969-3421

AFCEE POC: Capt Yen

NEWARK AFB OH (AFMC)
POC: Rob Large
AGMC/EM
813 Irving-Wick Dr. West
Newark AFB OH 43057-0024
DSN 346-8076
COM 614-522-7077
FAX 614-522-8865

AFCEE POC: Capt Yen

OFFUTT AFB NE (ACC)

POC: Mr. Phil Cork

55 CES/CEVR

M B B 19

106 Peacekeeper Dr. Suite 2N3

Offutt AFB NE 68113-4019

DSN 271-4087/7619

COM 402-294-4087/7619

FAX 402-294-3969

AFCEE POC: Capt Yen

PATRICK AFB FL (SPACECOM)

POC: Ed Worth

45 CES/DEEV

1224 Jupiter St., Bldg 1224

Patrick AFB FL 32925-3343

DSN 854-7288

COM 407-494-7288

FAX 854-2529

AFCEE POC: Capt Yen

PLATTSBURGH AFB NY (AMC)

POC: Brady Baker

380 SPTG/CEV

324 Oval Street

Plattsburgh AFB NY 12903-3316

DSN 689-6672

COM 518-565-6672

FAX 518-565-5167

AFCEE POC: Jerry Hansen

RANDOLPH AFB TX (ATC)

POC: Dennis Kirsch

12 CES/DEV

1651 5th Street West

Randolph AFB TX 78150-4513

DSN 487-4668

COM 210-652-4668

AFCEE POC: Sam Taffinder

TINKER AFB OK (AFMC)

POC: Jerry Forste

OC-ALC/EMR

Tinker AFB OK 73145-5000

DSN 884-3058

FAX 884-4210

AFCEE POC: Jerry Hansen

TRAVIS AFB CA (AMC)
POC: Glenn Anderson
60 AW/EMC
420 Airman Drive
Travis AFB CA 94535-2041
DSN 837-4359
COM 707-424-4359

AFCEE POC: Sam Taffinder

VANDENBERG AFB CA (SPACECOM)
POC: Layi Oyelowo
730 CES/CEVR
1172 Iceland Ave.
Vandenberg AFB CA 93437-6011
DSN 275-8399
COM 805-734-8232 + ext. (58399)

AFCEE POC: Sam Taffinder

WESTOVER AFB MA (AFRES)
POC: Jack Moriarty/Jim Kelly
Base Civil Engineer
250 Patriot Ave., Suite 1
Westover AFB MA 01022-1670
DSN 589-2434/2485
COM 413-557-2434/2485
FAX 413-557-2419

AFCEE POC: Jerry Hansen

WHITEMAN AFB MO (ACC)
POC: Marvin Eaves
351 CES/CEV
920 Arnold Ave., Suite 101
Whiteman AFB MO 65305-5000
DSN 975-6263
COM 816-687-6263

AFCEE POC: Jerry Hansen

Section 2.2. All drafts will be clearly marked as drafts but will be complete in every required detail. After AFCEE review, ES will have 15 days to incorporate the revisions (if any) and to provide AFCEE with the final reports.

5.2 EQUIPMENT AND MATERIAL PROCUREMENT

Equipment and material procurement under this contract will be competitive and purchased items will represent the best combination of low cost and product quality. All equipment items which cost more than \$1000.00 will be purchased based on an analysis of at least three written bids. All items which cost more than \$200.00 will be purchased from at least three verbal or written bids. A bid analysis summary (Figure 5.1) will be completed for all equipment exceeding the \$200.00 limit. For equipment and materials items costing less than \$200.00 every effort should be made to obtain quality at the lowest cost.

Requisition forms and purchase orders will reflect the proper task cost code, a complete description of the item ordered, the date of order, expected date of delivery and vendor point of contact. Once delivered to ES Denver or another field location, the bill of lading and condition of equipment will be carefully checked by the ES person ordering the equipment. Invoices will be presented to the project manager for final approval before payment.

Purchased test equipment will be added to the AFCEE bioventing equipment kit and assigned to a specific test team. Each team will maintain their own equipment inventory and will be responsible for keeping equipment properly maintained and accounted for. Equipment purchased with AF funds (gas analyzers, blower units) will be accounted for by serial number and will become AF property at the end of the contract.

5.3 MAINTENANCE OF PROJECT DOCUMENTS

Central files will be maintained in the Denver office and follow the designations in Table 5.2. Files maintenance is the primary responsibility of the project administrator but is a shared responsibility of every team member. File numbers should be written in the upper right hand corner of every document using the designations in Table 5.2. To insure proper filing, a basket will be established in the project administrator's office. Any document borrowed from the file should be replaced with a borrower's card.

5.4 COST AND SCHEDULE CONTROLS

5.4.1 Cost Control

Budget

The average cost for conducting all phases of initial pilot testing and extended pilot testing on a base with one or multiple sites is provided in Table 5.4. This generic budget and the task manpower allocations provided in Section 4 should be used as a budgetary guide for team managers. The goal of each team manager should be to complete the required tasks at or below the budgetary guideline. On

TABLE 5.2
CENTRAL FILES INDEX

File No.	Document
268	File Index
268.01	Project Management Primary Contract Modifications Statement of Work Original Proposal Project Management Plan Quality Assurance Plan
268.02	General Project Correspondence To/From AFCEE To/From Other ES Offices Other General Correspondence
268.03	Project Cost Controls Proposed Budget Total Job Cost Summaries Reports To/From ES Austin Monthly Cost Reports to AFCEE Equipment/Materials Invoices Job Cost Summaries By Base
268.04	Progress and Schedule Reports Monthly Progress Reports Quarterly Schedules
268.05	Subcontract Contracts/Billings Drillers Electricians Others
268.06	Quality Assurance QA Plan QA Audits Corrective Actions
268.07	Health and Safety Health and Safety Plan Field Audits Corrective Actions
268.08 thru 268.49	Specific Base Files(At least 38 bases)

TABLE 5.2 (Continued)
CENTRAL FILES INDEX

Example:
268.08

F.E. Warren AFB, WY

Subfiles

- 268.08.A - Test Work Plan
 - H&S Plan
 - Site Checklist
 - Raw Data
 - Schedule
- 268.08.B - Regulatory Permits (obtained by ES or Air Force)
- 268.08.C - Correspondence
- 268.08.D - Field Test Results/Calculations
- 268.08.E - Interim Test Results Report
- 268.08.F - Laboratory Results
- 268.08.G - Extended Testing Results
- 268.08.H - System Repairs
- 268.08.I - Cost Summaries and Invoices
- 268.08.J - Other

Other Bases	Abbreviation	Number of Sites	
268.09	Hill AFB, UT	HL	8
268.10	Offutt AFB, NE	OF	4
268.11	Whiteman AFB, MO	WH	1
268.12	Plattsburgh AFB, NY	PL	4
268.13	K.I. Sawyer AFB, MI	KIS	2
268.14	Battle Creek ANGB, MI	BA	2
268.15	McGuire AFB, NJ	MC	2
268.16	Tinker AFB, OK	TI	1
268.17	AF Plant 4, TX	AFP	2
268.18	Dyess AFB, TX	DY	5
268.19	Kelly AFB, TX	KE	2
268.20	Beale AFB, CA	BE	3
268.21	Travis AFB, CA	TR	2
268.22	Vandenberg AFB, CA	VA	2
268.23	Edwards AFB, CA	ED	3
268.24	March AFB, CA	MA	2
268.25	LA AFS, CA	LA	3
268.26	Cape Canaveral, FL	CA	5
268.27	Patrick AFB, FL	PA	5
268.28	Charleston AFB, SC	CH	2
268.29	Hickam AFB, HI	HI	3
268.30	AFP PJKS, CO	PJKS	1
268.31	Grissom AFB, IN	GR	1
268.32	Plattsburgh AFB (II), NY	PLZ	2
268.33	Randolph AFB, TX	RA	1
268.34	Kirtland AFB, NM	KL	3
268.35	Bolling AFB, D.C.	BO	2

TABLE 5.2 (Continued)
CENTRAL FILES INDEX

268.36	McClellan AFB, CA	ML	3
268.37	Westover AFB, MA	WE	3
268.38	Malmstrom AFB, MT	MS	2
268.39	Hanscom AFB, MA	HA	3
268.40	Fairchild AFB, WA	FA	4
268.41	Elmendorf AFB, AK	ELM	3
268.42	Ellsworth AFB, SD	ELS	4
268.43	Eglin AFB, FL	EG	3
268.44	AF Academy, CO	AFA	1
268.45	AFP6, GA	AFP6	1
268.46	Little Rock AFB, AR	LR	2
268.47	McClellan AFB (II), CA	ML2	3
268.48-79	Reserved		
268.80	Final Report		
268.80.01	Laboratory Results		

sites with deep drilling requirements (>40 feet) or high per diem rates, the team manager may authorize an increased budget. The team manager will receive a weekly job cost summary for each base he/she is responsible for. The project manager will receive a weekly cost summary of all activities.

Time Sheets

Time will be reported on time sheets using the cost codes identified in Table 5.3. Project billing numbers have been established for each task and each base.

The project manager will be responsible for ensuring that the total hours on the task order estimate are distributed among the available time sheet codes based on the approved cost estimate. If budget overruns are anticipated, a revised estimate will be prepared for that task order. The project manager is responsible for notifying the Air Force of an impending overrun, and justifying it with an estimate for remaining work on that task before accounting will accept charges in excess of those originally budgeted.

Before any out of scope work will be performed the cost impact will be discussed with the project manager. If a significant cost impact will result, the project manager will contact AFCEE and request written permission to proceed with out of scope work. Written AFCEE permission is required to justify later contract modifications.

Invoices and Expense Sheets

All invoices and weekly expense sheets will be approved by the team manager before they are forwarded to ES Austin or ES Pasadena for processing and payment.

5.4.2 Schedule Controls

Once each week Team Managers will provide a telephone update to the Project Manager to the progress of their assigned sites.

On the 3rd of each month, Team Managers will provide a paragraph describing the progress on each of their assigned basis including any work completed during the last 30 days. This informal report will be faxed to the ES Denver project administrator for incorporation into the monthly progress report to AFCEE.

Progress will be updated monthly in the progress report, and reported to the Air Force with percent-complete estimates for tasks in progress. A narrative description of accomplishments for the month will be included. If a trend is observed that indicates the project is falling behind schedule, the Project Manager will discuss methods of schedule correction with the AFCEE TPM and any budgetary impact.

Manpower levels will be predicted by the schedule, which is based upon the cost estimate for each task and site activity. This will be adjusted periodically to reflect actual manpower levels utilized during activities at sites where work has been completed. Manpower forecasts will be reviewed by the Project Manager with the other key project personnel to be certain that sufficient staff is always available to support this project.

TABLE 5.3
PROJECT COST CODES

Program Management (Includes the following tasks: project mobilization, subcontract preparation and oversight, initial meeting, initial schedule preparation, conceptual test work plan/H&S plan, monthly reporting)

<u>Task</u>	<u>Cost Code</u>
Labor	DE268.01.01
Travel/PerDiem	DE268.01.02
Other ODCs (Equipment Purchases)	DE268.01.03
Program Meetings (no base meetings)	
Labor	DE268.02.01
Travel/PerDiem	DE268.02.02
Other ODCs	DE268.02.03
Laboratory Costs for Battelle Sites	
ES Lab Charges	DE268.03.03
Subcontract Lab Charges	DE268.03.04
Reserved	DE268.04 - 268.07
Base Specific Costs	DE268.08 - 268.79
Example: F.E. Warren AFB	DE268.08
Initial Base Meeting	DE268.08.01
Test Work Plan/H&S Plan	DE268.08.02
Regulatory Permits	DE268.08.03
Construct/Conduct Pilot Test	DE268.08.04
Interim Report	DE268.08.05
Extended Testing	DE268.08.06
System Repair	DE268.08.07
ES Laboratory Costs	DE268.08.08
Subcontract Lab Costs	DE268.08.09
Other Bases	
DE268.09	Hill AFB, UT
DE268.10	Offutt AFB, NE
DE268.11	Whiteman AFB, MO
DE268.12	Plattsburgh AFB, NY
DE268.13	K.I. Sawyer AFB, MI
DE268.14	Battle Creek ANGB, MI
DE268.15	McGuire AFB, NJ
DE268.16	Tinker AFB, OK

TABLE 5.3 (Continued)

PROJECT COST CODES

<u>Task</u>	<u>Cost Code</u>
Other Bases (Continued)	
DE268.17	AF Plant 4, TX
DE268.18	Dyess AFB, TX
DE268.19	Kelly AFB, TX
DE268.20	Beale AFB, CA
DE268.21	Travis AFB, CA
DE268.22	Vandenberg AFB, CA
DE268.23	Edwards AFB, CA
DE268.24	March AFB, CA
DE268.25	LA AFS, CA
DE268.26	Cape Canaveral, FL
DE268.27	Patrick AFB, FL
DE268.28	Charleston AFB, SC
DE268.29	Hickam AFB, HI
DE268.30	AFP PJKS, CO
DE268.31	Grissom AFB, IN
DE268.32	Plattsburgh AFB (II), NY
DE268.33	Randolph AFB, TX
DE268.34	Kirtland AFB, NM
DE268.35	Bolling AFB, D.C.
DE268.36	McClellan AFB, CA
DE268.37	Westover AFB, MA
DE268.38	Malmstrom AFB, MT
DE268.39	Hanscom AFB, MA
DE268.40	Fairchild AFB, WA
DE268.41	Elmendorf AFB, AK
DE268.42	Ellsworth AFB, SD
DE268.43	Eglin AFB, FL
DE268.44	AF Academy, CO
DE268.45	AFP6, GA
DE268.46	Little Rock AFB, AR
DE268.47	McClellan AFB (II), CA
DE268.48-79	Reserved

APPENDIX F
LABORATORY ANALYTICAL RESULTS

August 7, 1992

GEOHYDRO

Lockheed Georgia Company
86 South Cobb Drive
Dept. 49-52, Zone 0444
Marietta, Georgia 30063

Attention: Mr. Richard Rexrode

Lockheed Georgia Company
Environmental Testing
Area G-10 and Area G-12
Marietta, Georgia
Our Project Number 111-92-21004

Gentlemen:

As requested, we have performed environmental sampling in Areas G-10 and G-12 at the Lockheed Georgia Company facilities. Four soil samples from area G-10 were collected at two locations at depths of 3.5 and 7.0 feet below prevailing ground surface utilizing a decontaminated stainless steel hand auger. Samples from each hand-auger boring were placed into the appropriate laboratory supplied containers, preserved in ice, and immediately transported to an analytical chemistry testing laboratory for TPH (EPA method 418.1) and BTEX (EPA method 8240) analyses. Table 1 and Figure 1 attached present a summary of sample designations, sampling depths and locations. A copy of the chain-of-custody and laboratory test results are also attached.

At area G-12 we collected water samples from monitoring wells G12-2 and G12-3. We also collected two soil samples from two shallow hand-auger borings performed in the creek's floodplain. Water samples were collected utilizing a decontaminated stainless steel bailer. Soil samples were collected utilizing a decontaminated stainless steel hand auger. Samples from each well and each hand-auger boring were placed into the appropriate laboratory supplied containers, preserved in ice, and immediately transported to an analytical chemistry testing laboratory. Table 2 and Figure 2 attached present a summary of sample designations, sampling depths and locations. A copy of the chain-of-custody and laboratory test results are also attached.

If you have any questions concerning this letter or any of our services, please contact our office.

Sincerely,

GEO-HYDRO ENGINEERS, INC.



Luis E. Babler, E.I.T.
Geotechnical Engineer

LEB\jm\21004L2

GEO-HYDRO ENGINEERS, INC.
1000 Cobb Place Boulevard
Suite 290
Kennesaw, Georgia 30144
(404) 426-7100



● Monitoring Well A-1

● Monitoring Well B-5

● G10 AGH2

● G10 AGH1

● Monitoring Well B-9

**Figure 1. Hand-Auger Boring Locations
Area G-10**



LEGEND: ● Hand-Auger Boring

○ Existing Monitoring Well

PROJECT: Environmental Testing
Lockheed Georgia Company
Area G-10

Our Project Number 111-92-21004

GEOHYDRO

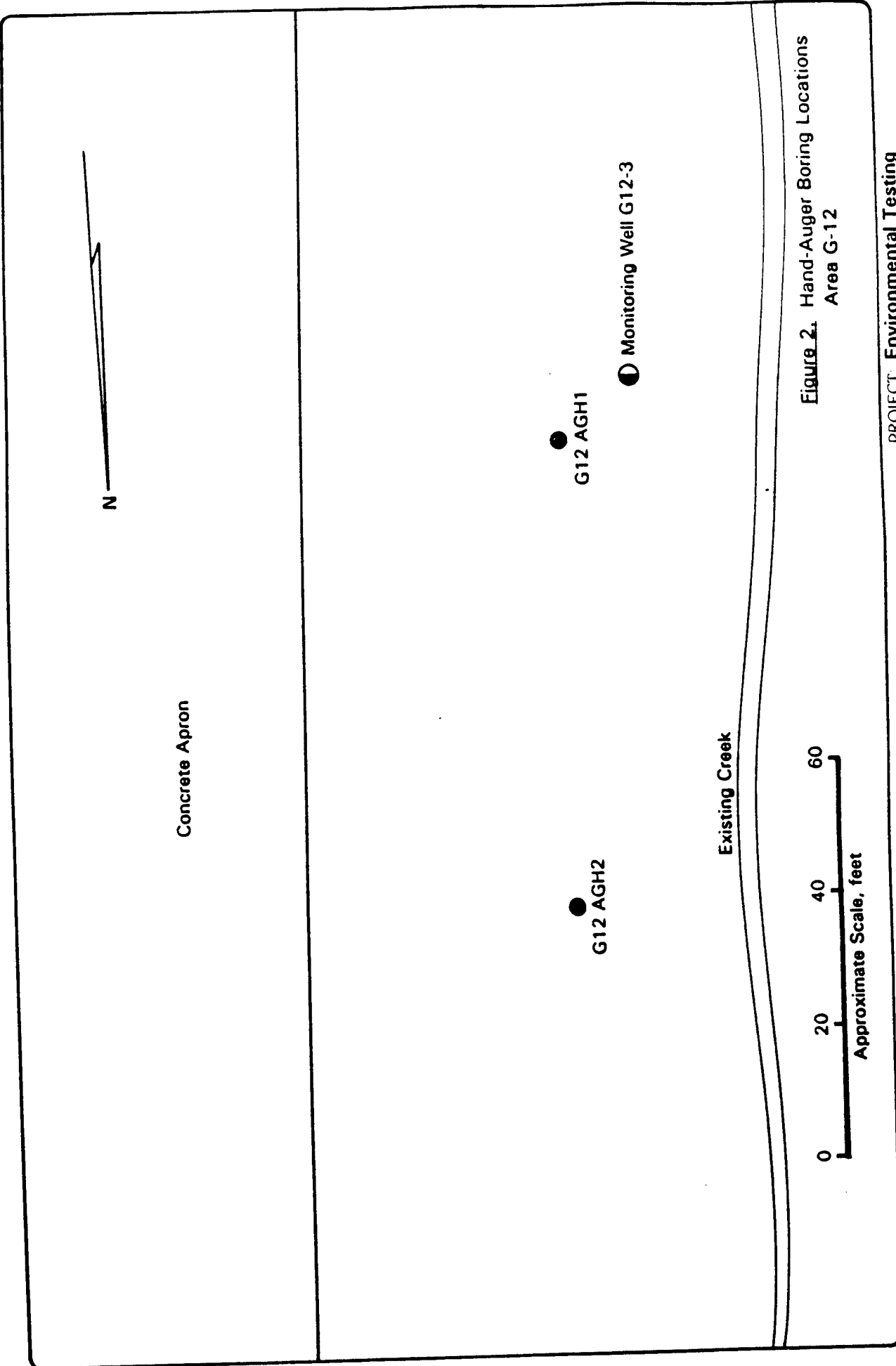

Figure 2. Hand-Auger Boring Locations
Area G-12

PROJECT: Environmental Testing

Lockheed Georgia Company

Area G-12

Our Project Number 111-92-21004

LEGEND: ● Hand-Auger Boring

⊙ Existing Monitoring Well

TABLE 1
ENVIRONMENTAL TESTING
LOCKHEED GEORGIA COMPANY
AREA G-10
OUR PROJECT NUMBER 111-92-21004

<u>Boring Location</u>	<u>Sample Designation</u>	<u>Matrix</u>	<u>Depth (ft.)</u>
AGH1	AGH1-1	Soil	3.5
AGH1	AGH1-2	Soil	7.0
AGH2	AGH2-1	Soil	3.5
AGH2	AGH2-2	Soil	7.0

TABLE 2
ENVIRONMENTAL TESTING
LOCKHEED GEORGIA COMPANY
AREA G-12
OUR PROJECT NUMBER 111-92-21004

<u>Sampling Location</u>	<u>Sample Designation</u>	<u>Matrix</u>	<u>Depth (ft.)</u>
Hand Auger Boring G12 AGH1	G12 AGH1-1	Soil	2.5
Hand Auger Boring G12 AGH2	G12 AGH2-1	Soil	2.5
Monitoring Well G12-2	G12-2	Water	Not applicable
Monitoring Well G12-3	G12-3	Water	Not applicable



ANALYTICAL SERVICES, INC.

ENVIRONMENTAL MONITORING & LABORATORY ANALYSIS
390 TRABERT AVENUE • ATLANTA, GEORGIA 30309 • (404) 892-8144
FAX (404)892-2740 • Federal I.D. #58-1625655

LABORATORY REPORT

Geo-Hydro Engineers
1000 Cobb Place Blvd.
Suite 290
Kennesaw, GA 30144

July 30, 1992

Attention: Mr. Louis Babler

Report No. 36355-1

Sample: Soil, Lockheed Aeronautical Systems, Project #111 92 21004, Area
G-10, AGH1-1, 7/22/92, 13:40, received 7/22/92

RESULTS

	<u>Result</u>	<u>Detection Limit</u>
Benzene (ug/kg) (EPA 8240).....	BDL	2500
Ethylbenzene (ug/kg) (EPA 8240).....	BDL	2500
Toluene (ug/kg) (EPA 8240).....	BDL	2500
Xylenes (ug/kg) (EPA 8240).....	BDL	2500
Total BTEX (ug/kg) (EPA 8240).....	BDL	2500
Total Petroleum Hydrocarbons (mg/kg) (EPA 418.1)	3040	10

BDL - Below Detection Limit

Respectfully submitted,

By: *Victor E. Bendeck, Jr.*

3-18000



ANALYTICAL SERVICES, INC.

ENVIRONMENTAL MONITORING & LABORATORY ANALYSIS
390 TRABERT AVENUE • ATLANTA, GEORGIA 30309 • (404) 892-8144
FAX (404)892-2740 • Federal I.D. #58-1625655

LABORATORY REPORT

July 30, 1992

Geo-Hydro Engineers
1000 Cobb Place Blvd.
Suite 290
Kennesaw, GA 30144

Report No. 36355-2

Attention: Mr. Louis Babler

Sample: Soil, Lockheed Aeronautical Systems, Project #111 92 21004, Area G-10, AGH1-2, 7/22/92, 13:40, received 7/22/92

RESULTS

	<u>Result</u>	<u>Detection Limit</u>
Benzene (ug/kg) (EPA 8240).....	BDL	500
Ethylbenzene (ug/kg) (EPA 8240).....	4700	500
Toluene (ug/kg) (EPA 8240).....	700	500
Xylenes (ug/kg) (EPA 8240).....	16000	500
Total BTEX (ug/kg) (EPA 8240).....	21400	500
Total Petroleum Hydrocarbons (mg/kg) (EPA 418.1)	4030	10

BDL - Below Detection Limit

Respectfully submitted,

By: *Victor E. Bendeck, Jr.*

3-18000



ANALYTICAL SERVICES, INC.

ENVIRONMENTAL MONITORING & LABORATORY ANALYSIS
390 TRABERT AVENUE ● ATLANTA, GEORGIA 30309 ● (404) 892-8144
FAX (404)892-2740 ● Federal I.D. #58-1625655

LABORATORY REPORT

July 30, 1992

Geo-Hydro Engineers
1000 Cobb Place Blvd.
Suite 290
Kennesaw, GA 30144

Report No. 36355-3

Attention: Mr. Louis Babler

Sample: Soil, Lockheed Aeronautical Systems, Project #111 92 21004, Area
G-10, AGH2-1, 7/22/92, 14:20, received 7/22/92

RESULTS

	<u>Result</u>	<u>Detection Limit</u>
Benzene (ug/kg) (EPA 8240).....	BDL	500
Ethylbenzene (ug/kg) (EPA 8240).....	2100	500
Toluene (ug/kg) (EPA 8240).....	BDL	500
Xylenes (ug/kg) (EPA 8240).....	2800	500
Total BTEX (ug/kg) (EPA 8240).....	4900	500
Total Petroleum Hydrocarbons (mg/kg) (EPA 418.1)	4170	10

BDL - Below Detection Limit

Respectfully submitted,

By: *Victor E. Bendeck, Jr.*

3-18000



ANALYTICAL SERVICES, INC.

ENVIRONMENTAL MONITORING & LABORATORY ANALYSIS
390 TRABERT AVENUE ● ATLANTA, GEORGIA 30309 ● (404) 892-8144
FAX (404)892-2740 ● Federal I.D. #58-1625655

LABORATORY REPORT

July 30, 1992

Geo-Hydro Engineers
1000 Cobb Place Blvd.
Suite 290
Kennesaw, GA 30144

Report No. 36355-4

Attention: Mr. Louis Babler

Sample: Soil, Lockheed Aeronautical Systems, Project #111 92 21004, Area
G-10, AGH2-2, 7/22/92, 14:25, received 7/22/92

RESULTS

	<u>Result</u>	<u>Detection Limit</u>
Benzene (ug/kg) (EPA 8240).....	BDL	2500
Ethylbenzene (ug/kg) (EPA 8240).....	6500	2500
Toluene (ug/kg) (EPA 8240).....	BDL	2500
Xylenes (ug/kg) (EPA 8240).....	21000	2500
Total BTEX (ug/kg) (EPA 8240).....	27500	2500
Total Petroleum Hydrocarbons (mg/kg) (EPA 418.1)	6860	10

BDL - Below Detection Limit

Respectfully submitted,

By: *Victor E. Bendeck, Jr.*

3-18000



ANALYTICAL SERVICES, INC.

ENVIRONMENTAL MONITORING & LABORATORY ANALYSIS
390 TRABERT AVENUE ● ATLANTA, GEORGIA 30309 ● (404) 892-8144
FAX (404)892-2740 ● Federal I.D. #58-1625655

LABORATORY REPORT

Geo-Hydro Engineers
1000 Cobb Place Blvd.
Suite 290
Kennesaw, GA 30144

August 6, 1992

Attention: Mr. Luis Babler

Report No. 36382-1

Sample: Soil, Lockheed Area G12, Project #1119221004, G12 AGH1-1,
7/23/92, 1300hrs, received 7/23/92

RESULTS

The sample was extracted and analyzed according to the procedures outlined in the TCLP Method 1311 promulgated as Appendix II, 55 FR 11862, March 29, 1990 (revised June 29, 1990). The results of the analysis are as follows:

<u>EPA HW Number</u>	<u>Parameter</u>	<u>Result (mg/l)</u>	<u>Detection Limit (mg/l)</u>	<u>Regulatory Limit (mg/l)</u>
D007	Chromium (Cr).....	BDL	0.01	5.0

BDL - Below Detection Limit

Respectfully submitted,

By:

3-16500



ANALYTICAL SERVICES, INC.

ENVIRONMENTAL MONITORING & LABORATORY ANALYSIS
390 TRABERT AVENUE • ATLANTA, GEORGIA 30309 • (404) 892-8144
FAX (404)892-2740 • Federal I.D. #58-1625655

LABORATORY REPORT

Geo-Hydro Engineers
1000 Cobb Place Blvd.
Suite 290
Kennesaw, GA 30144

August 6, 1992

Attention: Mr. Luis Babler

Report No. 36382-2

Sample: Soil, Lockheed Area G12, Project #1119221004, G12 AGH2-1,
7/23/92, 1320hrs, received 7/23/92

RESULTS

The sample was extracted and analyzed according to the procedures outlined in the TCLP Method 1311 promulgated as Appendix II, 55 FR 11862, March 29, 1990 (revised June 29, 1990). The results of the analysis are as follows:

<u>EPA HW Number</u>	<u>Parameter</u>	<u>Result (mg/l)</u>	<u>Detection Limit (mg/l)</u>	<u>Regulatory Limit (mg/l)</u>
D007	Chromium (Cr).....	BDL	0.01	5.0

BDL - Below Detection Limit

Respectfully submitted,

By:

3-16500



ANALYTICAL SERVICES, INC.

ENVIRONMENTAL MONITORING & LABORATORY ANALYSIS
390 TRABERT AVENUE ● ATLANTA, GEORGIA 30309 ● (404) 892-8144
FAX (404) 892-2740 ● Federal I.D. #58-1625655

LABORATORY REPORT

Geo-Hydro Engineers
1000 Cobb Place Blvd.
Suite 290
Kennesaw, GA 30144

August 6, 1992

Attention: Mr. Luis Babler

Report No. 36382-4

Sample: Groundwater, Lockheed Area G12, Project #1119221004, Well G12-2,
7/23/9, 1350hrs, received 7/23/92

RESULTS

	<u>Result</u>	<u>Detection Limit</u>
pH (laboratory) (EPA 9040).....	6.72	-
Specific Conductance (umhos/cm @ 25°C) (EPA 9050).....	1685	1
Oil and Grease (mg/l) (EPA 413.1).....	BDL	5
Total Chromium (Cr) (mg/l) (EPA 6010).....	BDL	0.01
Total Organic Carbon (TOC) (mg/l) (EPA 9060)...	16.5	1.0
Total Organic Halogens (TOX) (mg/l) (EPA 9020).	0.016	0.01

BDL - Below Detection Limit

Respectfully submitted,

By:

3-17000



ANALYTICAL SERVICES, INC.

ENVIRONMENTAL MONITORING & LABORATORY ANALYSIS
390 TRABERT AVENUE • ATLANTA, GEORGIA 30309 • (404) 892-8144
FAX (404)892-2740 • Federal I.D. #58-1625655

LABORATORY REPORT

Geo-Hydro Engineers
1000 Cobb Place Blvd.
Suite 290
Kennesaw, GA 30144

August 6, 1992

Attention: Mr. Luis Babler

Report No. 36382-3

Sample: Groundwater, Lockheed Area G12, Project #1119221004, Well G12-3,
7/23/92, 1420hrs, received 7/23/92

RESULTS

	<u>Result</u>	<u>Detection Limit</u>
pH (laboratory) (EPA 9040).....	6.62	-
Specific Conductance (umhos/cm @ 25°C) (EPA 9050).....	174	1
Oil and Grease (mg/l) (EPA 413.1).....	BDL	5
Total Chromium (Cr) (mg/l) (EPA 6010).....	BDL	0.01
Total Organic Carbon (TOC) (mg/l) (EPA 9060)...	1.9	1.0
Total Organic Halogens (TOX) (mg/l) (EPA 9020).	0.005	0.005

BDL - Below Detection Limit

Respectfully submitted,

By:

3-17000

APPENDIX G
EMISSION ISOLATION FLUX CHAMBER METHODOLOGY

Jeff

*PHOTO COPY
1/15/85*

PB86-223161

Measurement of Gaseous Emission Rates from
Land Surfaces Using an Emission
Isolation Flux Chamber. User's Guide

Radian Corp., Austin, TX

Prepared for

Environmental Monitoring Systems Lab.
Las Vegas, NV

Feb 85

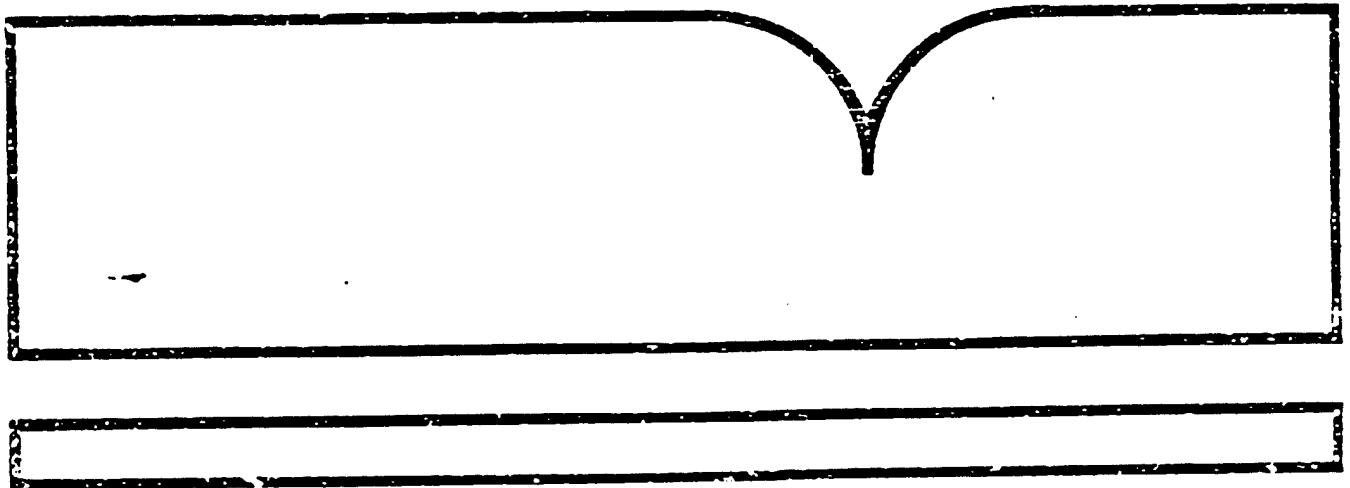

U.S. Department of Commerce
National Technical Information Service

NTIS

EPA/600/8-86/008
February 1986

MEASUREMENT OF GASEOUS EMISSION
RATES FROM LAND SURFACES
USING AN EMISSION
ISOLATION FLUX CHAMBER

USER'S GUIDE

by
M. R. Klenbusch
RadJan Corporation
P.O. Box 9948
Austin, Texas 78766

EPA Contract No. 68-02-3889
Work Assignment 18

Project Officer: Shelly J. Williamson
Exposure Assessment Division
Environmental Monitoring Systems Laboratory
Las Vegas, Nevada 89114

ENVIRONMENTAL MONITORING SYSTEMS LABORATORY
OFFICE OF RESEARCH AND DEVELOPMENT
U.S. ENVIRONMENTAL PROTECTION AGENCY
LAS VEGAS, NV 89114

REPRODUCED BY
NATIONAL TECHNICAL
INFORMATION SERVICE
U.S. DEPARTMENT OF COMMERCE
SPRINGFIELD, VA 22161

TECHNICAL REPORT DATA <i>(Please read instructions on the reverse before completing)</i>		
1. REPORT NO. EPA/600/8-86/008	2.	3. RECIPIENT'S ACCESSION NO.
4. TITLE AND SUBTITLE MEASUREMENT OF GASEOUS EMISSION RATES FROM LAND SURFACES USING AN EMISSION ISOLATION FLUX CHAMBER USER'S GUIDE	5. REPORT DATE February 1986	
	6. PERFORMING ORGANIZATION CODE	
7. AUTHOR(S) M. R. Klenbusch	8. PERFORMING ORGANIZATION REPORT NO.	
9. PERFORMING ORGANIZATION NAME AND ADDRESS Radian Corporation P.O. Box 9948 Austin, TX 78766	10. PROGRAM ELEMENT NO. ABSDIA	
	11. CONTRACT/GRANT NO. Contract, Radian Corp. No. 68-02-3889	
12. SPONSORING AGENCY NAME AND ADDRESS Environmental Monitoring Systems Laboratory - LV, NV Office of Research and Development U.S. Environmental Protection Agency Las Vegas, NV 89114	13. TYPE OF REPORT AND PERIOD COVERED User's Guide	
	14. SPONSORING AGENCY CODE EPA/600/07	
15. SUPPLEMENTARY NOTES		
16. ABSTRACT A promising method for monitoring ground emissions involves the use of an emission isolation flux chamber. The method is simple, easily available, and inexpensive. Applications would include RCRA and CERCLA facilities. To date, a uniform method operations does not exist. For this reason, an operations guide has been developed. This guide presents literature surveys, operation protocols, a case study, and references for further reading. The use of this protocol will aid in unifying flux chamber measurements and increase data comparability.		
17. KEY WORDS AND DOCUMENT ANALYSIS		
18. DESCRIPTORS	19. IDENTIFIERS/OPEN ENDED TERMS	20. COSATI Field Group
18. DISTRIBUTION STATEMENT RELEASE TO PUBLIC	19. SECURITY CLASS (This Report) UNCLASSIFIED	21. NO. OF PAGES 60
	20. SECURITY CLASS (This page) UNCLASSIFIED	22. PRICE

INSTRUCTIONS

1. **REPORT NUMBER**
Insert the EPA report number as it appears on the cover of the publication.
2. **LEAVE BLANK**
3. **RECIPIENTS ACCESSION NUMBER**
Reserved for use by each report recipient.
4. **TITLE AND SUBTITLE**
Title should indicate clearly and briefly the subject coverage of the report, and be displayed prominently. Set subtitle, if used, in smaller type or otherwise subordinate it to main title. When a report is prepared in more than one volume, repeat the primary title, add volume number and include subtitle for the specific title.
5. **REPORT DATE**
Each report shall carry a date indicating at least month and year. Indicate the basis on which it was selected (e.g., date of issue, date of approval, date of preparation, etc.).
6. **PERFORMING ORGANIZATION CODE**
Leave blank.
7. **AUTHOR(S)**
Give names in conventional order (John R. Doe, J. Robert Doe, etc.). List author's affiliation if it differs from the performing organization.
8. **PERFORMING ORGANIZATION REPORT NUMBER**
Insert if performing organization wishes to assign this number.
9. **PERFORMING ORGANIZATION NAME AND ADDRESS**
Give name, street, city, state, and ZIP code. List no more than two levels of an organizational hierarchy.
10. **PROGRAM ELEMENT NUMBER**
Use the program element number under which the report was prepared. Subordinate numbers may be included in parentheses.
11. **CONTRACT/GRANT NUMBER**
Insert contract or grant number under which report was prepared.
12. **SPONSORING AGENCY NAME AND ADDRESS**
Include ZIP code.
13. **TYPE OF REPORT AND PERIOD COVERED**
Indicate interim final, etc., and if applicable, dates covered.
14. **SPONSORING AGENCY CODE**
Insert appropriate code.
15. **SUPPLEMENTARY NOTES**
Enter information not included elsewhere but useful, such as: Prepared in cooperation with, Translation of, Presented at conference, to be published in, Supersedes, Supplements, etc.
16. **ABSTRACT**
Include a brief (200 words or less) factual summary of the most significant information contained in the report. If the report contains a significant bibliography or literature survey, mention it here.
17. **KEY WORDS AND DOCUMENT ANALYSIS**
 - (a) **DESCRIPTORS** - Select from the Thesaurus of Engineering and Scientific Terms the proper authorized terms that identify the major concept of the research and are sufficiently specific and precise to be used as index entries for cataloging.
 - (b) **IDENTIFIERS AND OPEN-ENDED TERMS** - Use identifiers for project names, code names, equipment designators, etc. Use open-ended terms written in descriptor form for those subjects for which no descriptor exists.
 - (c) **COSATI FIELD GROUP** - Field and group assignments are to be taken from the 1965 COSATI Subject Category List. Since the majority of documents are multidisciplinary in nature, the Primary Field/Group assignment(s) will be specific discipline, area of human endeavor, or type of physical object. The application(s) will be cross-referenced with secondary Field/Group assignments that will follow the primary posting(s).
18. **DISTRIBUTION STATEMENT**
Denote releasability to the public or limitation for reasons other than security for example "Release Unlimited." Cite any availability to the public, with address and price.
19. & 20. **SECURITY CLASSIFICATION**
DO NOT submit classified reports to the National Technical Information Service.
21. **NUMBER OF PAGES**
Insert the total number of pages, including this one and unnumbered pages, but exclude distribution list, if any.
22. **PRICE**
Insert the price set by the National Technical Information Service or the Government Printing Office, if known.

NOTICE

The information in this document has been funded wholly or in part by the United States Environmental Protection Agency under Contract No. 68-02-3889 to Radian Corporation. It has been subject to the Agency's peer and administrative review, and it has been approved for publication as an EPA document.

TABLE OF CONTENTS

<u>Section</u>	<u>Page</u>
1 INTRODUCTION	1-1
2 BACKGROUND	2-1
2.1 Emission Processes.	2-1
2.2 Measurement Techniques.	2-2
2.3 Flux Chamber Operation.	2-3
3 MEASUREMENT OF GASEOUS EMISSION RATES FROM LAND SURFACES USING AN EMISSION ISOLATION FLUX CHAMBER - PROPOSED METHOD	3-1
3.1 Applicability and Principle	3-1
3.1.1 Applicability.	3-1
3.1.2 Principle.	3-1
3.2 Precision, Accuracy, Sensitivity, and Range	3-1
3.2.1 Precision.	3-1
3.2.2 Accuracy	3-2
3.2.3 Sensitivity.	3-2
3.2.4 Range.	3-2
3.3 Interferences	3-2
3.3.1 Flux Chamber Method.	3-2
3.3.2 Emission Process	3-4
3.4 Apparatus and Materials	3-4
3.4.1 Flux Chamber and Supporting Equipment.	3-4
3.4.2 Discrete Sample Collection	3-6
3.4.3 Analysis	3-6
3.5 Procedure	3-11
3.5.1 Flux Chamber Operation	3-11
3.5.2 Sample Collection.	3-11
3.5.3 Sample Analysis.	3-13
3.5.4 Sampling Strategy.	3-15
3.6 Calibration	3-18
3.6.1 Equipment.	3-18
3.6.2 Analyzers.	3-19
3.7 Quality Control	3-20
3.7.1 Sampling Equipment	3-20
3.7.2 Sampling	3-22
3.7.3 Analytical	3-22
3.8 Calculations.	3-23
3.8.1 Definitions.	3-23
3.8.2 Percent Recovery	3-25
3.8.3 Calculation of the Dilution Factor involved In Gas Canister Analysis	3-27
3.8.4 Area Source Emission Rate Equations.	3-27
4 CASE STUDY	4-1
5 ADDITIONAL INFORMATION	5-1
REFERENCES	R-1
APPENDIX A - SELECTION OF A RANDOM SAMPLE.	A-1

FIGURES

<u>Number</u>		<u>Page</u>
3-1	A Cutaway Diagram of the Emission Isolation Flux Chamber and Support Equipment.	3-5
3-2	Exploded View of the Flux Chamber.	3-9
3-3	Flux Chamber Gas Emission Measurements Field Data Sheet. . .	3-12
3-4	Stainless Steel Gas Canister and Sampling Manifold (not to scale)	3-14
3-5	Chain-of-Custody Form for Gas Canister Samples	3-21
3-6	Nested Sampling Scheme	3-24
4-1	Schematic Diagram of Bonifay Spill Site, Monitor Wells, and Exploratory Borings (Brown and Kirkner, Inc., 1983).	4-2
4-2	Schematic Diagram of Sampling Grid with Subsurface Plume at Bonifay Spill Site.	4-4
4-3	Field Data Sheet for Isolation Flux Chamber Sampling at Grid Point 08	4-6

TABLES

<u>Number</u>		<u>Page</u>
3-1	Compounds Tested in the Emission Isolation Flux Chamber and the Measured Percent Recovery.	3-3
3-2	Flux Chamber Materials Specifications.	3-7
3-3	Total Sample Size Required Based on the Preliminary Sample Coefficient of Variation Estimate	3-17
3-4	Tabulated Values of Student's "t".	3-26
4-1	Field Data Sheet for Undisturbed Surface Survey.	4-3
4-2	Results of GC Analysis of Gas Syringe Taken During Flux Chamber Sampling.	4-7
4-3	Sample Calculation of the Emission Rate for Grid Point Point 08 on 1/13/84.	4-8

SECTION 1

INTRODUCTION

Volatilization of organic compounds from contaminated soil or groundwater into the air represents a major potential source of exposure which has not been assessed. In order to assess this exposure potential, a method is needed to directly measure gas emission rates from contaminated soils and/or groundwater. Additionally, it is recognized that an understanding of the volatilization, transport, and emission processes could lead to a predictive tool for exposure assessment. The information provided by direct measurement and/or predictive modeling will allow state and local regulatory agencies to develop programs to assess and define the need to control gas emissions from area sources contaminated by organic compounds.

The purpose of this User's Guide is to present an approach and protocol, namely the emission isolation flux chamber (or flux chamber) technique, for measuring emission rates of volatile organic compounds from contaminated soils and/or groundwater. Presented is the theory of operation, specifications, sensitivities, method of operation, and data reduction procedures for this technique. It is assumed that the individuals who will use the protocol are, in general, familiar with sample collection and analysis of volatile organic compounds. Also included in this document is a case study that demonstrates the measurement and data reduction processes around a spill site.

The flux chamber technique is applicable to the measurement of emission rates from Resource Conservation and Recovery Act (RCRA) facilities (hazardous waste landtreatment, and landfill facilities), and from Comprehensive Environmental Response, Compensation, and Liability Act (CERCLA) area sources contaminated by losses of volatile organic compounds from spills, from leaking underground storage tanks, from pipelines, and/or from surface impoundments.

This protocol does not present the vast amount of work that was required to develop this document. Rather, the protocol is a result of literature reviews selecting a measurement technique and field applications demonstrating the technique and developing a data base and validation studies identifying the method of flux chamber operation. References to the other area sources where this technique was applied, the work performed to validate the technique, and the investigations of variables which control the emission process are also given for those individuals desiring further information.

SECTION 2

BACKGROUND

The following subsections discuss the process by which volatile organic compounds are emitted from contaminated land surfaces, the basis upon which the flux chamber technique was selected as an approach for measuring such emission rates, and the principle of the technique.

2.1 Emission Processes

The rate of volatile organic compound (VOC) emissions from contaminated soils is generally believed to be controlled by the diffusion rate of the chemical compound through the air-filled pore spaces of the soil.(1,2,3) The exception occurs when the contaminated material lies on or very near the soil surface. Such is the case when spills occur or immediately after waste is surface-applied to a landtreatment site. In these cases, the emission process will be controlled by the rate of evaporation.

Evaporation is a surface phenomenon, and the parameters that affect the evaporation process are the properties of the waste itself as well as those that have an effect on the air-surface interface (i.e. wind, surface roughness). The important parameters include the volatility or vapor pressure of the waste, ambient meteorological conditions (solar insolation, air and waste temperature, surface wind speed, relative humidity), surface coarseness, and the bulk concentration of the volatile components in the air (although this is usually very low and generally assumed to be negligible).

There are two major types of soil emission processes. Each are treatment dependent. One type occurs in landtreatment facilities and the other at underground facilities such as landfills. In landtreatment applications, the emission rate is generally highly time-dependent. When a fixed amount of waste is applied to the soil surface, it penetrates the soil to a certain depth. The vaporization rate is maximum immediately after waste application, as the material nearest the surface is vaporized and diffuses through a very thin layer of soil. As the waste near the surface is depleted of its VOC content, the volatile material deeper in the soil must diffuse through an increasingly thick soil layer. The soil presents a resistance to VOC diffusion in direct proportion to the VOC depth. Thus, the rate of emissions from the surface decreases with time.

It is common practice in landtreatment to periodically till the soil to provide oxygen for bacterial activity. The tilling effectively mixes the remaining waste in a homogeneous layer near the soil surface. The emission rate is at a maximum immediately following each tilling episode since

volatile waste is again present very near the surface, and resistance to diffusion is at a minimum.

Although also diffusion controlled, the emission process from underground sources such as landfilled waste or material present as a "lens" on the water table has significantly different characteristics than that from surface or near-surface sources. The depth of the emission source is usually quite substantial. Therefore, the emission rate is initially lower due to the resistance to diffusion produced by the column of soil. The initial emission rate is zero, since it takes some time for the volatile material to diffuse through the soil layer. The adsorptive sites on the soil particles must also be initially saturated. Once the emission rate has equilibrated, the rate is relatively constant with time until the underground source is exhausted.

The diffusion process itself through the soil is the same for both types of sources, land treatment (surface) and landfill (underground). Consequently, many of the parameters important to the emission processes are the same, including diffusivity of the VOC in air, soil properties (particle size distribution, soil type, moisture content, particle density, porosity), soil/waste temperature, and volatility of the VOC in the waste. Additional parameters important to the near surface emission processes are the amount of material present in the contaminated soil layer, the initial depth of the contamination, the elapsed time from application (or tillage) and, possibly, ambient conditions such as surface wind speed and relative humidity. The depth of the soil layer above the waste is a very important parameter in the emission process from subsurface sources. Additionally, the adsorptive properties of the soil may also have a significant effect on the emission rate from this latter source type.

An understanding of the emission processes and the important parameters is necessary in the measurement of emission rates from soil surfaces and in the proper interpretation of the test results. As an example, the emission rate from a source is affected by rain since the porosity and, hence, the diffusion rate are reduced with increasing moisture content of the soil. Thus, emission rates immediately after a rainfall will be lower than those from drier soils and may take substantial periods of time to return to the emission rate prior to the rain. (4) Emission rates may vary with the time of day and season, as a result of changes in ambient and soil/waste temperatures. (4) Emission rates from soil areas containing fissures can be higher and much less homogeneous than those from unfractured areas. Thus, considerable care must be taken in planning and implementing a measurement program to determine representative emission rates from such soil surfaces.

2.2 Measurement Techniques

Based on a literature review (5), the techniques for determining gas emissions rates from land surfaces contaminated with organic compounds can be divided into three approaches: indirect measurements, direct measurements, and laboratory simulations. Indirect techniques typically require measurements of ambient air concentrations at or near the site. These

measurements are related to the surface area of the area source and local meteorological conditions using a dispersion model to determine an emission rate. The second approach is to directly measure emission rates using for example the flux chamber. The third approach is to create an emission source in the laboratory and model the emissions by various techniques for application to field sites. These three approaches were compared for precision, accuracy, and sensitivity. Other considerations included applicability, complexity, manpower requirements, and costs.

The most promising technique for measuring gas emission rates from land surfaces was determined to be the emission isolation flux chamber technique. The advantages are:

- o lowest (most sensitive) detection limit of the methods examined;
- o easily obtained accuracy and precision data;
- o simple and economical equipment relative to other techniques;
- o minimal manpower and time requirements;
- o rapid and simple data reduction; and
- o applicable to a wide variety of surfaces.

2.3 Flux Chamber Operation

The flux chamber technique has been used by researchers to measure emission fluxes of sulfur, nitrogen, and volatile organic species (6,7,8,9,10). This approach uses a flux chamber (enclosure device) to sample gaseous emissions from a defined surface area. Clean dry sweep air is added to the chamber at a fixed, controlled rate. The volumetric flow rate of sweep air through the chamber is recorded and the concentration of the species of interest is measured at the exit of the chamber. The emission rate is calculated as:

$$E_1 = Y_1 Q / A \quad (2-1)$$

where: E_1 = emission rate of component 1 (mass/area-time),
 Y_1 = concentration of component 1 in the air flowing from the chamber (mass/volume),
 Q = flow rate of air into the chamber (volume/time),
 A = surface area enclosed by the chamber (area).

All parameters in Equation 2-1 are measured directly.

Most of the emission rate assessments are of area sources much larger than the enclosed surface area of the flux chamber (0.130 m²). In these

C 1.4 E-3

cases, an overall emission rate for the area source is calculated from multiple measurements based on random sampling and statistical analysis.

SECTION 3

MEASUREMENT OF GASEOUS EMISSION RATES FROM LAND SURFACES USING AN EMISSION ISOLATION FLUX CHAMBER - PROPOSED METHOD

3.1 Applicability and Principle

3.1.1 Applicability

The flux chamber technique is applicable to the measurement of emission rates from Resource Conservation and Recovery Act (RCRA) facilities such as hazardous waste landtreatment and landfill facilities. This technique is also applicable for emission rate measurements from Comprehensive Environmental Response, Compensation, and Liability Act (CERCLA) waste sites such as areas contaminated by losses of volatile organic compounds from spills, from leaking underground storage tanks, from pipelines, and/or from surface impoundments.

3.1.2 Principle

Gaseous emissions are collected from an isolated surface area with an enclosure device called an emission isolation flux chamber (or flux chamber). The gaseous emissions are swept through an exit port where the concentration is monitored and/or sampled. The concentration is monitored and/or sampled either continuously (i.e., "real-time") or discretely. Real-time measurements are typically made with portable total hydrocarbon analyzers and are useful for relative measurements (i.e., the determination of flux chamber steady-state operation, zoning). Discrete samples are taken when absolute measurements are necessary (i.e., steady-state concentrations, emission rate levels). The emission rate is calculated based upon the surface area isolated, the sweep air flow rate, and the gaseous concentration measured. An estimated average emission rate for the area source is calculated based upon statistical sampling of a defined total area.

3.2 Precision, Accuracy, Sensitivity, and Range

3.2.1 Precision

Single chamber precision (i.e., repeatability) of the method is approximately 5 percent at measured emission rates of 3,200 ug/min·m². Variability between different flux chambers (i.e., reproducibility) is approximately 9.5 percent within a measured emission rate range of 39,000 to 65,000 ug/min·m². (4)

The reproducibility results were determined from a bench-scale study. The tests were designed to eliminate temporal variations from the flux chamber reproducibility. However, using the same bench-scale facility, a test design was not possible for measuring flux chamber repeatability without bias from temporal variations. As a result, the repeatability tests were performed in the laboratory. The differences therefore between the stated emission rates for repeatability and reproducibility reflect the differences in laboratory simulated emission rates and those measured from the bench-scale facility.

3.2.2 Accuracy

Flux chamber recovery (Section 3.6.1.4.2) results show a recovery range of 77 percent to 124 percent. Table 3-1 lists measured recoveries for a number of compounds tested. The average recovery for the 40 compounds tested is 103 percent.

Flux chamber emission rate measurements made on the soil cells range from 50 percent to 100 percent of the predicted emission rates. That is, the measured emission rates can be expected to be within a factor of one-half of the "true" emission rates. (4) The flux chamber accuracy based upon both the recovery tests and predictive modeling ranges from 50 percent to 124 percent.

3.2.3 Sensitivity

The sensitivity of this method depends on the detection limit of the analytical technique used. When discrete samples are collected using gas canisters and analyzed by gas chromatographic methods, the estimated emission rate sensitivity is $1.2 \text{ ug/min}\cdot\text{m}^2$ for an analytical detection limit of 10 ppbv benzene. When emission rates are measured in a continuous (real-time) method, the estimated sensitivity is $124 \text{ ug/min}\cdot\text{m}^2$ for an analytical detection limit of 1 ppmv benzene.

3.2.4 Range

The range of this method depends upon the analytical technique used. High level emission rates are analyzed by introducing proportional amounts of gas sample to the analyzer. Using this technique, high level emission rates of $120,000 \text{ ug/min}\cdot\text{m}^2$ have been measured. (4) Low levels are limited by the sensitivity of the analytical technique. Gas chromatographic techniques have been used to measure low level emission rates of $1.2 \text{ ug/min}\cdot\text{m}^2$ for measured concentrations of 10 ppbv benzene.

3.3 Interferences

3.3.1 Flux Chamber Method

Impurities in the sweep air and/or organic compounds outgassing from the transfer lines and acrylic chamber top may cause background contamination. The emission isolation flux chamber must be demonstrated to be free

TABLE 3-1
 COMPOUNDS TESTED IN THE EMISSION ISOLATION FLUX CHAMBER
 AND THE MEASURED PERCENT RECOVERY

Compound	Percent Recovery*	Compound	Percent Recovery*
Total C ₂	100	3-methylhexane	106
Total C ₃	108	2,2,4-trimethylpentane	106
Isobutane	109	n-heptane	103
1-butene	108	Methylcyclohexane	103
n-butane	106	Toluene	103
t-2-butane	107	Ethyl benzene	94.7
c-2-butene	109	mtp-xylene	88.5
Isopentane	112	o-xylene	97.3
1-pentene	105	n-nonane	99.4
2-methyl-1-butene	124	n-propylbenzene	95.5
n-pentane	107	p-ethyltoluene	92.5
n-pentene	103	1,3,5-trimethylbenzene	93.5
c-2-pentene	105	1,2,4-trimethylbenzene	88.7
Cyclopentene	105	2-methyl-2-butene	103
n-hexane	95.1	Methyl mercaptan	107
Isohexane	107	Ethyl mercaptan	107
3-methylpentane	106	Butyl mercaptan	101
Methylcyclopentane	105	Tetrahydrothiophene	115
Benzene	106	Trichloroethylene	77.1
1,2-Dimethylpentane	105	Ethylene dichloride	103

*Section 3.8.2

from significant (<10 percent of expected measured concentrations) levels of such contamination under the measurement operating conditions by running method blanks. Background levels above this limit will significantly bias the flux chamber measurements. Typical values measured with a real-time analyzer (OVA) range from 0 to 2 ppmv exit gas concentration.

Cross-contamination can occur whenever high level and low level samples are sequentially analyzed. To reduce the likelihood of cross-contamination, the chamber should be purged between samples with ultra high purity air and followed with running a method blank until typical values are achieved.

The use of a transparent chamber may result in gas and surface warming due to greenhouse effects. The degree of gas and surface warming are dependent upon the outside air temperature. For outside air temperatures of 28°C, a temperature gradient between the inside flux chamber air and outside air increases from 9°C at 5t (30 minutes) to 30°C 2.5 hours later. Such heating is minimized by the use of short sampling times.

As a result of the greenhouse effect, condensation may occur when monitoring moist surfaces. Condensation should be recorded when observed and dried from chamber surfaces and lines between sample runs. Condensation could reduce exit gas concentrations of water soluble compounds.

The emission rate process from soils enclosed by the flux chamber could be suppressed as the internal VOC vapor phase concentration increases. Emission rate suppression is avoided by increasing the sweep air flow rate. Suppression is not a significant factor until flux chamber entrapped vapor concentrations are greater than 10 percent of the equilibrium vapor phase concentration. The equilibrium vapor phase concentration is determined from the headspace concentration measurements of a soil sample. This concern applies only when sampling highly concentrated and volatile waste.

3.3.2 Emission Process

Ground moisture resulting from either rain, heavy dew, etc. has a definite effect upon the emission rate from land surfaces. Ground moisture accumulation from trace amounts of rain (≤ 0.01 inches) have little or no effect, whereas ground moisture resulting from a rainfall of 0.30 inches of water has been observed to decrease emission rates by 90 percent. (4) At this level of precipitation, seven days of hot, sunny weather were required before the gas emission rates returned to values equal to that before the rain. As such, emission rate measurements made on soils recently experiencing an elevated ground moisture content would be biased. Emission rate measurements will be below those made at normal soil moisture levels.

3.4 Apparatus and Materials

3.4.1 Flux Chamber and Supporting Equipment

A diagram of the flux chamber and supporting equipment is shown in Figure 3-1. The flux chamber materials and specifications are listed in

FIGURE 3-1
 A CUTAWAY DIAGRAM OF THE EMISSION ISOLATION FLUX CHAMBER, AND
 SUPPORT EQUIPMENT

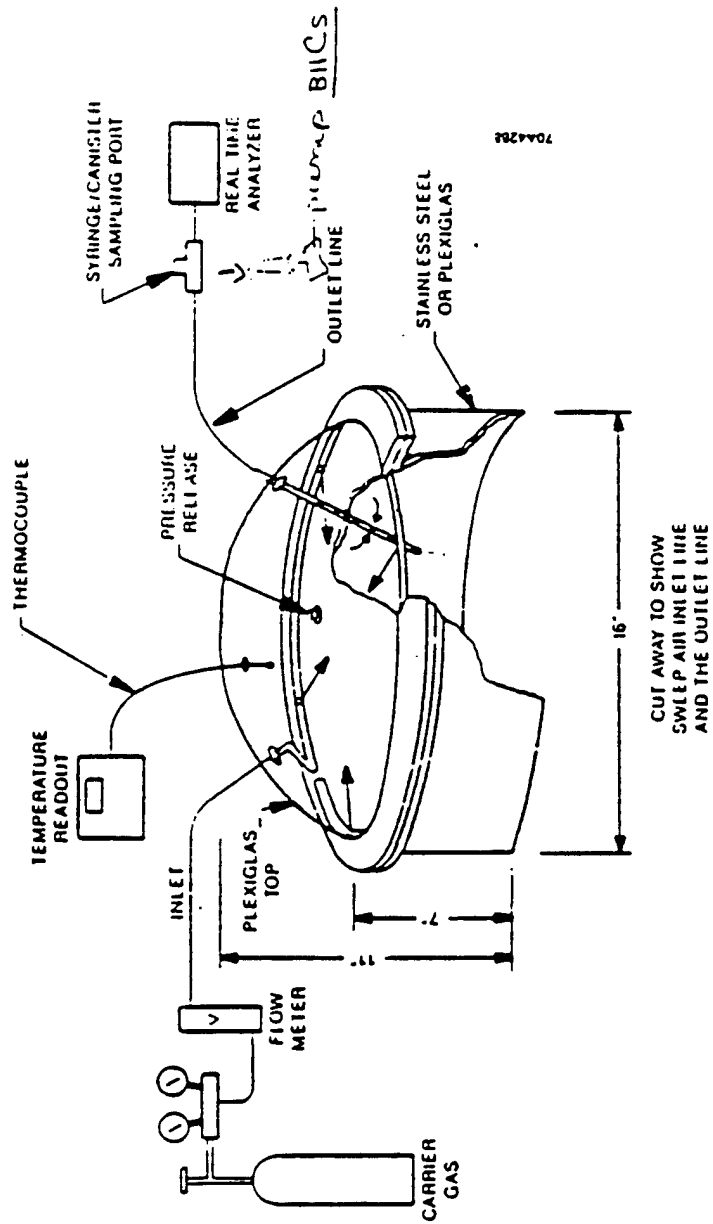

Table 3-2. A construction diagram of the flux chamber is shown in Figure 3-2.

The sweep air carrier gas should be dry, organic free air equal to or better than commercial ultra high purity grade (<0.1 ppmv THC). A gas flow meter with no internal rubber parts and adjustable within the range of 1-10 L/min should be used to control gas flow. Temperature measurements should be made with an accuracy of $\pm 1.0^\circ\text{C}$. A fine-wire thermocouple with electronic readout is recommended. Caution should be taken to avoid any contact of a thermocouple with metal. This would give inaccurate air temperature readings. A pressure release port is required to avoid pressure build-up inside the flux chamber during operation. This port should never be blocked. For system blanks, a clean Teflon[®] sheet should be used to provide a clean surface for the flux chamber.

3.4.2 Discrete Sample Collection

Discrete grab samples should be collected with air-tight, inert containers. For on-site analysis, 100 ml precision lock, glass syringes are recommended. Glass plungers are recommended over Teflon[®] tip plungers. If Teflon[®] tip plungers are used, then special controls must be followed to avoid cross-contamination (Section 3.7.1.1). For samples to be transported or to be stored for periods longer than 1 hour, 2L stainless steel gas canisters are recommended.

3.4.3 Analysis

3.4.3.1 Real Time

Analyzer

For real-time, continuous monitoring of the exit gas concentration, analyzers with precision of ± 10 percent of the measured value and a detection limit of 1 ppmv are recommended.

Calibration Gases

The portable, real-time analyzers will require the following levels of calibration gases:

- o High-Level Gas: Concentration within 50 percent to 90 percent of the span value (maximum expected concentration or upper limit of instrument linear range).
- o Low-Level Gas: Concentration less than or equal to 0.01 percent of the span value.
- o Zero Grade Gas: Ultra high purity (UHP) air (<0.1 ppmv THC).

The calibration gas for these analyzers can be the same as that used for the on-site discrete analyzer (Section 3.4.3.2.2).

TABLE 3-2
FLUX CHAMBER MATERIALS SPECIFICATIONS

Item	Description	Specification
Carrier Gas Lines: Inlet/Outlet	Teflon [™] (clear)	1/4" OD, 5' to 8' long, thin walled, 1/4" stainless steel fittings
Sweep Air Wrap Perforation ^a	Stainless Steel four equidistant holes jetting direction	1/4" OD, 54" long, perforated hole No. 1 (nearest input), 5/64" ID, holes No. 2-4, 3/32" ID, axially, horizontally
Fittings ^b	Stainless steel Stainless steel	1/4" bulkheads with teflon washers for chamber penetration 1/4" cap to seal wrap line end
Thermocouples Air (1)	Fine wire K type	36" long, bead tip, teflon coated (extensions optional), penetrate flux chamber 3", support with 1/4" bulkhead with septa
Flux Chamber: Base	Stainless steel column	16" ID x 7" tall, welded to a support ring flange
Support ring flange	Stainless steel	16" ID x 20" OD x 1/4" thick
Dome	Acrylic four holes	Spherical, 4" displacement at center, 16" ID at seal, 2" lip for seal, 1/4" thick, molded Equidistant, 4" from aluminum gasket
	Inlet/outlet	1/2" ID with 1/4" stainless steel bulkhead
	Air temperature	1/2" ID with 1/4" stainless steel bulkhead
	Pressure release	13/16" ID with 3/4" stainless steel bulkhead
Seal Dome to Base	Top gasket Dome lip	Aluminum 16" ID, 20" OD, 1/4" thick Below aluminum gasket is the acrylic lip of dome

(Continued)

TABLE 3-2
(Continued)

Item	Description	Specification
	Sealing washer	Teflon, 16" ID, 20" OD, 1/32" thick
	Bottom gasket Fasteners	Stainless steel support ring 20, 1/4" bolts equidistant around lip
Volume	With 1" soil penetration	0.03 m ³ (30L)
Surface Area	Enclosed by chamber	0.130 m ²
Exit Line Probe	Teflon ^a	1/4" OD, 6" long, stainless steel fitting, perforated
Perforation	2 rows of holes	3/32" ID, 5 holes per row, 1" separation, rows are positioned orthogonally

^aAvoid placement of exit line probe in jetting path of sweep air inlet holes

^bAll fittings are manufactured by Swagelok[®] or equivalent manufacturer (bulkheads use Teflon[™] washers for sealing)

FIGURE 3-2
EXPLODED VIEW OF THE FLUX CHAMBER

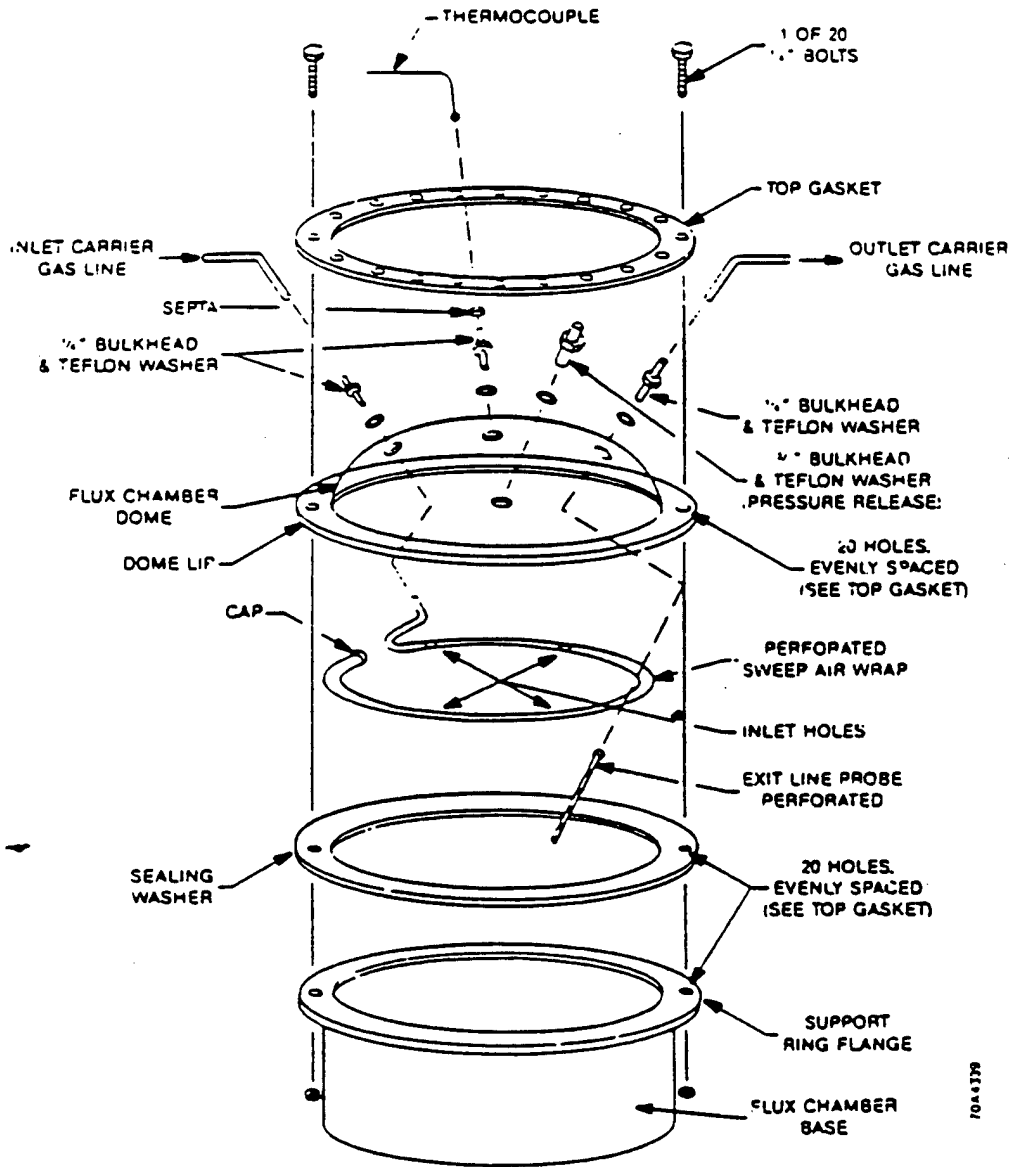

Quality Control (QC) Gas

The portable, real-time analyzer will require a quality control (QC) gas concentrated to fall within the span range. The QC gas for this analyzer can be the same as that used for the on-site discrete analyzer.

3.4.3.2 Discrete

Analyzer

The analyzer should be sensitive with low detection limits. For on-site analysis of grab samples, instrumentation having precision of ± 5 percent of the measured value with a detection limit of 1 ppm is recommended. Analyzers with injection loops are recommended to reproduce the sample volumes injected. For off-site analysis, instrumentation with precision of ± 30 percent at detection limits of 1 ppbv are recommended.

Calibration Gases

The concentrations and composition of the calibration gases to be used will vary depending on the species of interest. Preferably, the following gas concentrations should be used for each species of interest:

- o High-Level Gas: 90 percent of the span value.
- o Mid-Level Gas: Average expected concentration.
- o Low-Level Gas: 0.01 percent of the span value.
- o Zero Grade Gas: Ultra high purity (UHP) air, (<0.1 ppmv THC).

Alternatively, a high-level gas may be used with a dilution system to generate the lower level gas concentrations. A dilution system is recommended that meets or exceeds that described in Section 6.2.1.1 of Method 15 of 40 CFR Part 60. If multicomponent species are analyzed, then on-site calibration gases should be benzene or hexane. To identify and quantitate multicomponent responses when a single component (benzene or hexane) is used for calibration, a library of normalized responses relative to the single component calibration gas must be employed. This does not guarantee all species of the multicomponent will be identified. If specific identification and quantitation are not required, then quantitation and identification should be made relative to the calibration gas.

QC Gas

The discrete analyzer will require a QC gas that has a concentration within the span range.

Steve
we used a
modified
version of
this
44 min not 54 min

3.5 Procedure

3.5.1 Flux Chamber Operation

The flux chamber is operated identically for real-time and discrete sampling.

3.5.1.1 Preparation

All exposed chamber surfaces should be cleaned with water and wiped dry prior to use. Assemble the sampling apparatus and check for malfunctions and leaks.

3.5.1.2 Operation

Place the flux chamber over the surface area to be sampled and work it into the surface to a depth of 2-3 cm. Initiate the sweep air and set the flow rate at 5 L/min. Record data at time intervals defined by residence times or τ (tau), where τ = flux chamber volume (30L)/sweep air flow rate (5L/min). One τ then has the value of 6 minutes under normal operating conditions. At $\tau = 0$ (flux chamber placement), record the following: time, sweep air rate, chamber inside air temperature, ambient air temperature, and exit gas concentration (real-time analyzer). The data should be recorded on the data sheet shown in Figure 3-3. At each residence time (τ , 6 minutes), the sweep air rate shall be checked (and corrected to 5 L/min if necessary), and the gas concentration shall be recorded (real-time analyzer). After 4 residence times (24 minutes), initiate sample collection. At this time, record the following data: time, sweep air rate, air temperatures inside and outside, exit gas concentration, and sample number(s). If sulfonated organic compounds are of specific interest, then measurements should be taken after 10 residence times (1 hour).

3.5.2 Sample Collection

3.5.2.1 Real Time

When real-time monitoring is required, the sample is collected by the real-time analyzer directly from the exit gas line.

3.5.2.2 Discrete Sample Collection

Sample collection should not exceed a flow rate of 2 L/min.

Gas Syringes

Sample collection with syringes should be performed after purging the syringe three times with the sample gas. This should be performed without removing the syringe from the sampling line manifold. To ensure fresh sample at each purge, a sampling manifold should be positioned prior to a real-time analyzer (Figure 3-1). The analyzer will then draw the sample past the manifold for sampling.

**FIGURE 3-3
FLUX CHAMBER GAS EMISSION MEASUREMENTS FIELD DATA SHEET**

FLUX CHAMBER EMISSIONS MEASUREMENT DATA

Date _____ Sampler(s) _____

Location _____ Zone/Grid Point _____

Surface Description _____

Concurrent Activity _____

Time	Sweep Air Rate, Q (L/Min)	Air Residence No. (Q/V)	Gas Conc. (ppmv)	Air Temperature Chamber (C)	Air Temperature Ambient (C)	Sample Type/No.	Comments:
		0					
		1					
		2					
		3					
		4					
		5					

Comments: _____

7-86-24843

Gas Canister

Sample collection with evacuated gas canisters should be performed with the real-time analyzer replaced by the gas canister (Figure 3-4).

To collect canister samples, remove the real-time analyzer from the exit line sampling manifold. Securely fasten the canister sampling manifold to the exit line manifold. Open the flow control valve (V_1 , Figure 3-4) slightly. If this valve is opened too much, the large pressure drop at the exit line inside the flux chamber could draw direct air jetting from the sweep air inlet manifold. This would reduce the measured emission rate. A large pressure drop inside the flux chamber could also draw ambient air in through the pressure release port. These concerns are important only when the exit line sampling rate approaches that of the entrance sweep air rate (5 L/min). If a 2L gas canister is used, then control the flow to fill the canister in 1 to 2 minutes. The use of a capillary flow controller between the exit line and canister could be used to control gas flow.

After sample collection, seal the sample valve (V_1) prior to removal from the sampling line. This prevents contamination. At this time, the sample is labeled and recorded. Record the final pressure of the canister.

3.5.3 Sample Analysis

3.5.3.1 Real Time

Real-time analysis is a continuous process with the real-time analyzer connected to the exit line. These data are an initial indication of the exit line concentration.

3.5.3.2 Discrete

Gas Syringes

Gas syringe samples collected should be treated promptly and consistently. Temperature differentials between the flux chamber air and the analytical laboratory air can cause changes in sample volume. It is recommended that the analytical air temperature be constant, recorded twice daily and within 10°F of the ambient outside air temperature. The samples should be analyzed either immediately upon arrival into the analytical area or allowed to thermally equilibrate (1-5 min depending on syringe size). Since immediate analysis is not always possible, the later technique is recommended.

Gas Canisters

Prior to sample preparation for analysis, the canister pressure should be measured. The canisters are then pressurized to 18 psi with ultra high purity nitrogen. Measure the final pressure. A known volume of diluted gas canister sample is taken from the canister by releasing sample into an evacuated volumetric stainless steel canister (3.55L). From this volumetric

FIGURE 3-4
STAINLESS STEEL GAS CANISTER AND SAMPLING MANIFOLD
(NOT TO SCALE)

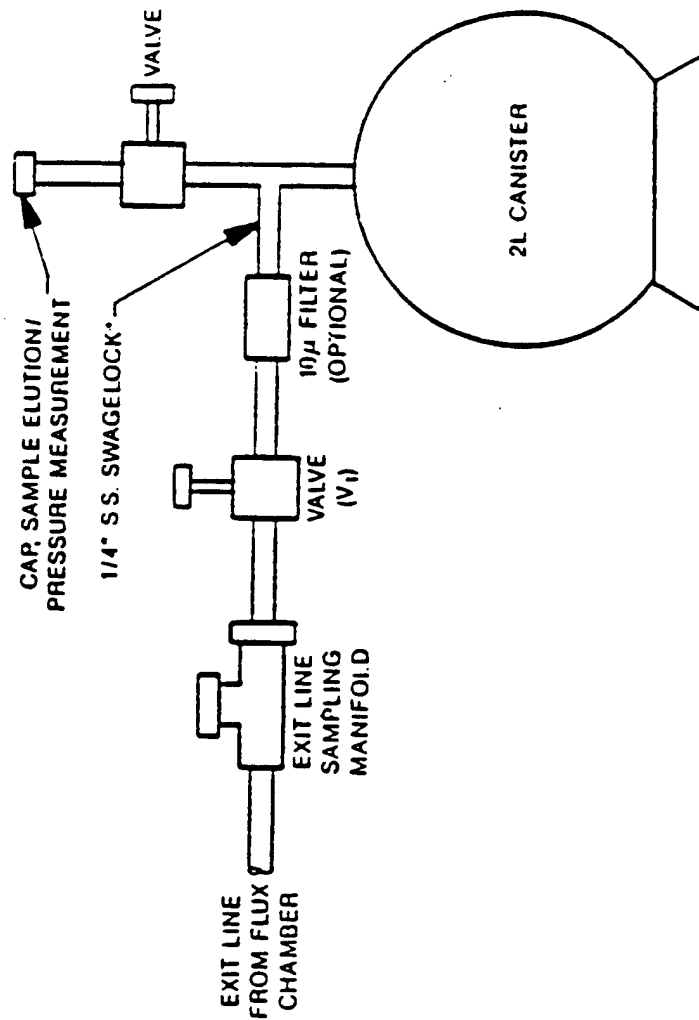

7044404

gas canister, the sample is then introduced into the gas chromatograph through cryogenic traps. The dilution factor is calculated by Equation 3-2 (Section 3.8.3).

3.5.4 Sampling Strategy

The following sampling strategy provides an accurate and precise estimate of the emission rate for a total area source through random sampling in which any location within the area source has a theoretically equal chance of being sampled. The sampling strategy described below provides an estimated average emission rate within 20 percent of the true mean with 95 percent confidence.

3.5.4.1 Zones

Based on area source records and/or preliminary survey data, subdivide the total area source into zones if nonrandom chemical distribution is exhibited or anticipated. The zones should be arranged to maximize the between-zone variability and minimize the within-zone variability.

3.5.4.2 Grids

Divide each zone by an imaginary grid with unit areas that depend on zone area size (Z) as follows:

If $Z \leq 500 \text{ m}^2$, then divide the zone area into units with areas equal to 5 percent of the total zone area (i.e., 20 units total).

If $500 \text{ m}^2 < Z \leq 4,000 \text{ m}^2$, then divide the zone area into units of area 25 m^2 .

If $4000 \text{ m}^2 < Z \leq 32000 \text{ m}^2$, then divide the zone area into 160 units.

If $Z > 32000 \text{ m}^2$, then divide the zone area into units with area equal to 200 m^2 .

Assign a series of consecutive numbers to the units in each zone.

3.5.4.3 Sample Number

Using Equation 3-3 (Section 3.8.4), calculate the number of units (grid points) to be sampled for the K th zone (n_k).

3.5.4.4 Sample Locations

Using the random numbers table (Appendix A), identify n_k grid points (units) that will be sampled in zone K . A grid point shall be selected for measurement only once. (This is not to be confused with duplicate sampling, Section 3.7.2.2.)

3.5.4.5 Emission Rate Calculations

After sample collection, use Equations 3-4, 3-5, 3-6, 3-7, and 3-8 to calculate the measured emission rate (E_{CKI}) for each grid point (I) in each zone (K). Research has shown an emission rate dependency upon the air temperature inside the flux chamber.(4) Through a statistical analysis of both laboratory and field data, a correction factor for temperature variations has been developed. The correction factor compensates a measured emission rate for chamber air temperature variations from the nominal chamber air temperature.

The nominal chamber air temperature can be defined in two ways depending on the purpose of emission rate measurements. If emission rate measurements are for an estimate of an area source, then the nominal chamber air temperature should be the mean chamber air temperature of all the measurements made at that area source. If emission rate measurements are compared between area sources, then the nominal chamber air temperature should be 25°C (298K).

3.5.4.6 Preliminary Estimates

With Equations 3-9, 3-10, and 3-11, calculate the zone mean emission rate (\bar{E}_K), variance (S_K^2), and coefficient of variation (CV_K), respectively. For these calculations, use the first emission rate measurement of a duplicate set.

3.5.4.7 Further Sampling

Use Table 3-3 and CV_K to determine the total number of samples (N_K) required from a given zone to estimate with 95 percent confidence an emission rate within 20 percent of the mean. If $N_K > n_K$, then $N_K - n_K$ additional samples must be collected from zone K. Locate these additional samples using a random numbers table. Do not duplicate previously sampled locations.

If $N_K \gg n_K$, it may be most effective to rezone using the preliminary measured emission rates as a guide. If new zones are established, then these new zones will need to be gridded accordingly (Section 3.5.4.2).

3.5.4.8 Final Estimates

Collect any additional samples and recalculate the emission estimates for the sample mean (\bar{E}_K) and variance (S_K^2) for each zone (Section 3.5.4.6). Then compute the overall area source mean (E) and variance (S^2) for the total site area using Equations 3-13 and 3-14, respectively. Determine the 95 percent confidence interval for each zone (CI_K) and for the site area (CI) using Equations 3-15 and 3-16.

TABLE 3-3
 TOTAL SAMPLE SIZE REQUIRED BASED ON THE PRELIMINARY
 SAMPLE COEFFICIENT OF VARIATION ESTIMATE*

Coefficient of Variation - CV (%)**	Number of Samples Required (N_K) per Zone K
0 - 19.1	6
19.2 - 21.6	7
21.7 - 24.0	8
24.1 - 26.0	9
26.1 - 28.0	10
28.1 - 29.7	11
29.8 - 31.5	12
31.6 - 33.1	13
33.2 - 34.6	14
34.7 - 36.2	15
36.3 - 37.6	16
37.7 - 38.9	17
39.0 - 40.2	18
40.3 - 41.5	19
41.6 - 42.8	20
42.9 - 43.9	21
44.0 - 45.1	22
45.2 - 46.2	23
46.3 - 47.3	24
47.4 - 48.4	25
48.5 - 49.5	26
49.6 - 50.7	27
50.8 - 51.6	28
51.7 - 52.3	29
52.4 - 53.4	30

*Value given is the sample size required to estimate the average emission rate with 95 percent confidence that the estimate will be within 20 percent of the true mean.

**For CVs greater than 53.4, the sample size required is greater or equal to $CV^2/100$.

3.6 Calibration:

3.6.1 Equipment

3.6.1.1 Flow Meters

The flow meter should be calibrated against an NBS-traceable bubble meter before sampling. The flow meter should have a working range of 2-10 L/min.

3.6.1.2 Thermocouple

Fine wire K-type insulated thermocouples are recommended for temperature measurements. Prior to field use, the thermocouple and readout should be calibrated against a mercury-in-glass thermometer meeting ASTM E-1 No. 63C or 63F specifications. The thermocouple should have an accuracy within $\pm 1^\circ\text{C}$.

3.6.1.3 Calibration Gases

For checking the concentrations of the calibration gases, use calibration gases that are documented traceable to National Bureau of Standard Reference Materials. Use Traceability Protocol for Establishing True Concentrations of Gases Used for Calibrations and Audits of Continuous Source Emission Monitors (Protocol Number 1) that is available from the Environmental Monitoring and Support Laboratory, Quality Assurance Branch, Mail Drop 77, Environmental Protection Agency, Research Triangle Park, North Carolina 27711. Obtain a certification from the gas manufacturer that the protocol was followed.

3.6.1.4 Flux Chamber System

Several tests should be performed to characterize a new flux chamber prior to use. These tests should be repeated if a chamber is exposed to severe conditions such as corrosive gases, extremely high levels of organic vapors, or organic liquids.

Blanks

Check the flux chamber for background by placing the chamber over a clean Teflon[®] surface and running a test using ultra high purity sweep air and routine operating conditions. Sample collection and analysis should be as previously described (Sections 3.5.2 and 3.5.3).

Recovery Efficiency

Check the flux chamber sample recovery efficiency by placing the chamber over a flat Teflon[®] surface containing an inlet port at the center for introduction of a calibration gas(es). The calibration gas should be that used for the on-site analyzer at a concentration of at least 1,000 ppmv (high-level gas). The calibration gas should be introduced into the chamber

at a flow rate of no greater than 0.5 L/min. Add ultra high purity sweep air concurrently through the enclosure sweep air inlet (5 L/min) and determine the concentration exiting the enclosure under routine operating conditions. Compare the measured concentration to the true concentration (corrected for dilution), and calculate a percent recovery using Equation 3-1. Results for a variety of volatile organic compounds are presented in Table 3-1. Results should be within 10 percent of the true concentration. The limited data characterizing the recovery efficiency for halogenated compounds indicate an acceptance level that may be larger than 10 percent.

Corrective Action

If the background levels of the flux chamber are greater than 10 percent of the measured concentrations or 10 ppmv, whichever is smaller, then rerun the blank sample. If high levels persist, then disassemble the flux chamber, clean all internal parts with water and replace those suspected to be contaminated, and reassemble for another blank run. Repeat above until satisfactory levels are reached.

If the recovery efficiency is below 90 percent for non-halogenated compounds, then rerun the recovery test. If low recoveries persist, check for poor sealing and/or inlet gas shortcutting directly from the input line to the exit line and/or misadjusted flow rate settings.

3.6.2. Analyzers

The following procedures should be performed at the recommended frequency during the analysis of flux chamber samples.

3.6.2.1 Real Time

Real-time analyzers are used more for relative, continuous measurements than for absolute measurements. If these analyzers are intended for absolute measurements, then they should be calibrated according to Section 3.6.2.2. Real-time analyzers may be used when data quality requirements are less stringent (Section 3.1.2). As such, these analyzers require less stringent quality control practices.

Each day prior to sampling, a three-point calibration should be performed on each analyzer (Section 3.4.3.1.2). Consider the calibration acceptable if responses are within ± 20 percent of the expected response. If the responses are not acceptable, then recalibrate the instrument.

3.6.2.2 Discrete Analyzer

Discrete analyzers are those that are the most relied upon for absolute, quantitative data of the analyzers used on site. As such, these analyzers require more stringent quality control practices (Section 3.1.2). The calibration procedure suggested here is for linear detectors (i.e., FID, PID). Compensations for non-linear detectors used for analysis of sulfonated compounds (flame photometric detectors) must be made.

Prior to each field investigation, a multipoint calibration including zero and at least three upscale concentrations (Subsection 3.4.3.2.2) should be performed to establish the linearity of the analyzer. The results may be used to prepare a calibration curve for each compound. Alternatively, if the ratio of GC response to amount injected (response factor) is a constant over the multipoint range (<10 percent coefficient of variation, standard deviation/mean), linearity through the origin can be assumed, and the average response factor can be used in place of a calibration curve.

Each day prior to sampling and after every fifth sample, the working calibration curve (or response factor) must be verified by the measurement of one or more calibration standards. If the response for any standard varies from the predicted response by 20 percent, the test must be repeated using a fresh calibration standard. If the analyzer response is still unacceptable, a new calibration curve (or response factor) must be prepared for that compound. A new calibration curve (or response factor) should be calculated after each verification of calibration using the acceptable results of the one or more calibration standards injected.

3.7 Quality Control

3.7.1 Sampling Equipment

3.7.1.1 Syringes

Prior to use for sample collection, all syringes should be challenged with one or more of the calibration standards. An acceptable response is within ± 10 percent of the predicted response. If the response is unacceptable, then repeat the test. Alternatively, check for leakage around the plunger or lock valve by pressurizing the syringe and submerging it under water. Syringes should be checked after every 25 to 30 uses or whenever leakage is suspected. If Teflon[™] tip plungers are used, then suspect memory effects after exposure to high levels of organics. In instances when memory effects are apparent, the Teflon[™] tips should be replaced.

3.7.1.2 Gas Canisters

Gas canisters should be cleaned and evacuated before each use. The pressure should be recorded after each evacuation. Prior to sample collection, check the pressure and compare it to that recorded after cleaning. Acceptable differences are <10 percent of the post evacuation pressure. Canisters having unacceptable pressure differences should not be used for sample collection.

To identify gas canisters and record pressure values, each gas canister should have a chain-of-custody form (Figure 3-5). Copies of this form should be retained for the sampler, laboratory, and sample control.

FIGURE 3-5
CHAIN-OF-CUSTODY FORM FOR GAS CANISTER SAMPLES

STAINLESS STEEL CANISTER
CHAIN OF CUSTODY

----- TO BE COMPLETED BY FIELD SAMPLER -----

SAMPLE CONTROL NUMBER: _____
 CANISTER NUMBER: _____
 DATE SAMPLED: _____ TIME: _____
 WELL/STATION NUMBER: _____
 OVA READING (P/AK): _____
 ADDRESS/REFINERY LOCATION: _____
 HEIGHT/DEPTH/ROOM: _____
 SAMPLER'S INITIALS: _____
 TASK: _____
 TYPE (CIRCLE ONE): _____ or POINT SOURCE (specify): _____
 COMMENTS: _____

----- TO BE COMPLETED BY LAB (PART ONE) -----

OPERATION	DATE	INITIALS	COMMENTS
1. Canister cleaned	_____	_____	_____
2. Filter cleaned	_____	_____	_____
3. Canister evacuated	_____	_____	Pressure: _____
4. Canister shipped	_____	_____	_____
5. Canister received	_____	_____	_____
6. Analysis completed	_____	_____	_____
7. Sample discarded	_____	_____	_____

----- TO BE COMPLETED BY LAB (PART TWO) -----

PARAMETER	DILUTION 1	DILUTION 2	DILUTION 3	DILUTION 4
Initial Pressure	_____	_____	_____	_____
Final Pressure	_____	_____	_____	_____
Add UHP Air	_____	_____	_____	_____
Dilution Factor	_____	_____	_____	_____
FINAL Dilution Factor	_____	_____	_____	_____

3.7.2 Sampling

These tests should be performed at the specified frequency during use of the flux chamber.

3.7.2.1 Sample Blanks

Sample blanks should be performed once daily or after extremely high-level samples. The flux chamber should be cleaned and blanks rerun until exit concentrations are <10 ppmv or <10 percent of expected concentrations, whichever is smaller.

3.7.2.2 Duplicate Samples

A minimum of 10 percent of the sampling points should be sampled in duplicate. Take the two sample over as brief a time span as feasible to minimize any temporal variations in the emitting source.

3.7.2.3 Control Point Samples

One sampling location (grid point or unit) in each zone should be resampled after every ten individual measurements (or a minimum of once per day) when an area source is being investigated. Preferably, this control point should be measured at different times during the diurnal cycle (maximum difference in ambient temperatures). These values provide a measure of temporal variability of the emission rate from the area source.

3.7.3 Analytical

3.7.3.1 Real-Time Analyzers

Real-time measurements are typically made with portable total hydrocarbon analyzers. Real-time analyses are useful for relative measurements (i.e., to determine if steady-state operation of the flux chamber has been attained or to determine the zoning boundaries). Each day following calibration, the analyzer should be challenged with the QC gas (Section 3.4.3.1.3). Analyzer performance should be considered acceptable if the measured concentration is within 20 percent of the certified concentration. If this criterion is not met, the QC analysis should be repeated. If the criterion is still not met, then daily calibration should be repeated.

At the conclusion of each day, the QC gas should be reintroduced to the analyzer. The difference between pretesting and posttesting responses provides a measure of upscale drift. Drifts >30 percent should be flagged and not relied upon. If these data are necessary, then resample the grid points sampled on that day.

3.7.3.2 Discrete Analyzers

Each day after calibration, the analyzer should be challenged with the QC gas (Section 3.4.3.2.3). Analyzer performance should be considered

acceptable if the measured concentration is within 10 percent of the certified concentration. If this criterion is not met, repeat the QC gas analysis. If the criterion still cannot be met, then repeat the daily calibration (Section 3.6.2.2).

At the conclusion of each day's testing, the QC gas and zero grade gas should be reintroduced to the analyzer. The differences between pretesting and posttesting values provide a measure of upscale and zero drifts. Daily drift results that show >20 percent should be flagged and tests repeated if determined necessary.

3.7.3.3 Analysis of Integrated Samples

Quality control for the analysis of integrated samples should include a minimum of 10 percent analytical blanks and 10 percent duplicate analysis. It is recommended that duplicate samples each be analyzed in duplicate to provide information on analytical as well as sampling variation. A convenient technique is the use of a nested sampling scheme as shown in Figure 3-6.

3.8 CALCULATIONS

3.8.1 Definitions

A = surface area enclosed by the flux chamber (0.130 m^2)

a = number of carbon atoms per compound molecule

CI = confidence interval for the area source emission rate mean ($\pm \text{ug}/\text{min}\cdot\text{m}^2$)

CI_K = confidence interval for the zone K emission rate mean ($\pm \text{ug}/\text{min}\cdot\text{m}^2$)

C_{IM} = measured concentration of species I (ppmv) corrected for dilution

C_{IT} = theoretical concentration of species I (ppmv)

C_{KI} = measured concentration for point I in zone K, total NMHC (ppmv-C)

CV_K = coefficient of variance for zone K (%)

\bar{E} = mean emission rate for the area source ($\text{ug}/\text{min}\cdot\text{m}^2$)

\bar{E}_K = zone K emission rate mean ($\text{ug}/\text{min}\cdot\text{m}^2$)

E_{KI} = measured emission rate for point I in zone K ($\text{ug}/\text{min}\cdot\text{m}^2$)

E_{CKI} = measured emission rate for point I in zone K ($\text{ug}/\text{min}\cdot\text{m}^2$) corrected for temperature variations

MW = molecular weight of compound (g/mole)

FIGURE 3-6
NESTED SAMPLING SCHEME

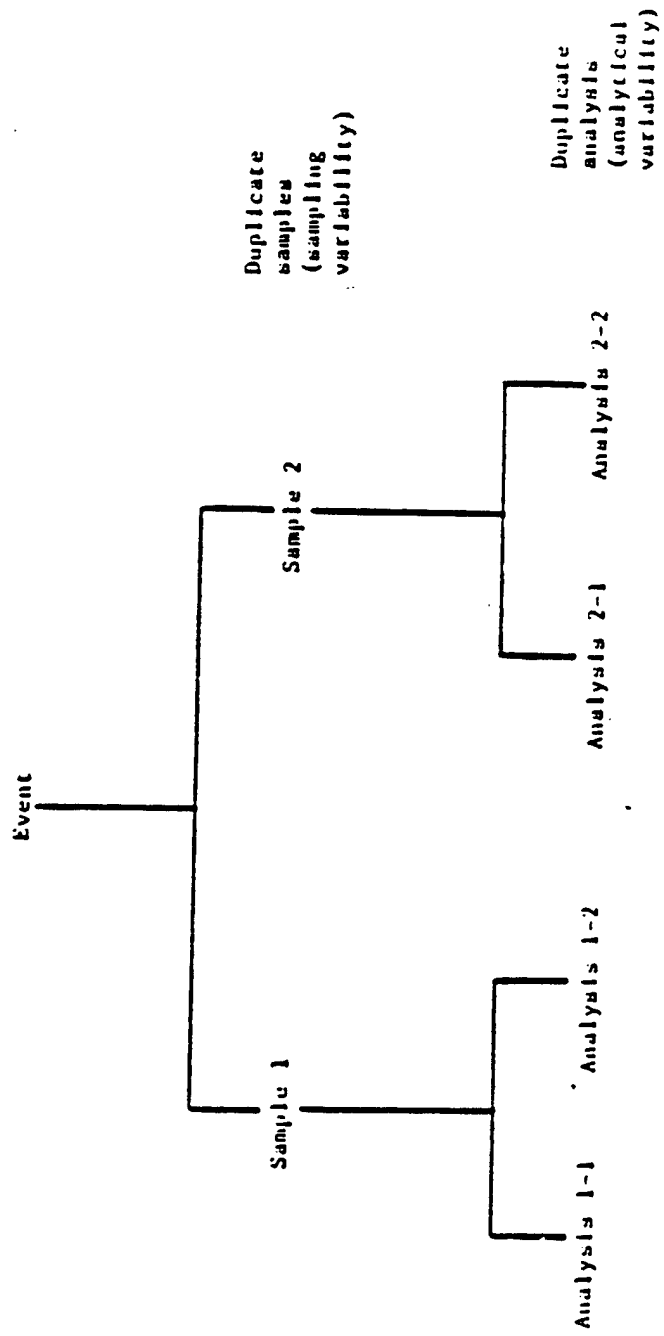

- N = total number of grid points sampled in the area source (all zones)
 N_K = final number of grid points (units) sampled in zone K
 n_K = initial number of grid points (units) sampled in zone K
 P = atmospheric pressure (atm)
 Q = sweep air flow rate (L/min)
 R = gas constant (0.08205 L·atm/mol·K)
 S = standard error of the overall area source emission rate mean (ug/min·m²)
 S_K^2 = zone K emission rate variance
 T = temperature of laboratory where analyzer is located (K)
TEMP = temperature of the flux chamber air (°C)
 $t_{0.025}$ = the 97.5th percentage point of a student's t-distribution (Table 3-4)
 V = volume enclosed by the flux chamber (30L)
 W_K = the fraction of the site represented by the zone K (zone area (m²)/site area (m²))
 Y_{KI} = measured concentration for point I in zone K, total NMHC (ug/L)
 α = parameter defining the level of confidence 100(1-2 α) percent
 Y = total number of zones in the total area source
 ρ = confidence interval (%)
 τ = measure of residence time = V/Q (min)

3.8.2 Percent Recovery

The percent recovery measurements used to characterize the flux chamber performance are calculated accordingly:

$$\text{Percent Recovery} = (C_{IM}/C_{IT}) \times 100 \quad (3-1)$$

where: C_{IM} = the measured concentration of species I (ppmv) corrected for dilution as follows:

$$C_{IM} = (1/DF) \times C \quad (3-1a)$$

TABLE 3-4
TABULATED VALUES OF STUDENT'S "t"

Degrees of Freedom*	Tabulated "t" Value**	Degrees of Freedom*	Tabulated "t" Value**
1	12.706	21	2.080
2	4.303	22	2.074
3	3.182	23	2.069
4	2.776	24	2.064
5	2.571	25	2.060
6	2.477	26	2.056
7	2.365	27	2.052
8	2.306	28	2.048
9	2.262	29	2.045
10	2.228	30	2.042
11	2.201	40	2.021
12	2.179	60	2.000
13	2.160	120	1.980
14	2.145	"	1.960
15	2.131		
16	2.120		
17	2.110		
18	2.101		
19	2.093		
20	2.086		

*Degrees of freedom (df) are equal to the number of samples collected less one.

**Tabulated "t" values are for a two-tailed confidence interval and a probability of 0.05 (the same values are applicable to a one-tailed confidence interval and a probability of 0.025).

where C is the sample concentration (ppmv) and
DF is the dilution factor calculated as follows:

$$S_1 / (S_2 + S_1) \quad (3-1b)$$

where S_1 is the flow rate of the trace gas and
 S_2 is the sweep gas flow rate

C_{1T} = the true concentration of species 1, gas cylinder value (ppmv)

3.8.3 Calculation of the Dilution Factor Involved in Gas Canister Analysis

Analyzing the gas canisters requires pressurizing the canister with nitrogen. This introduces a dilution which must be accounted for as follows:

$$DF = (P_2 - P_1) / (14.7 + P_3) \quad (3-2)$$

where: P_1 = the measured pressure after cleaning and canister evacuation prior to sampling (psig)
 P_2 = the measured pressure after sample collection (psig)
 P_3 = the measured pressure after pressurizing with nitrogen (psig)

The temperature is not required if all pressure measurements used in this equation are performed in the same laboratory (i.e., same temperature) after the canisters have thermally equilibrated.

3.8.4 Area Source Emission Rate Equations

The number of units or grids (n_K) to be sampled per zone (K) is dependent upon the zone area as follows:

$$n_K = 6 + 0.15 \sqrt{\text{area of zone } m^2} \quad (3-3)$$

Flux chamber measurements taken at each sampling unit are converted from ppmv-C to ug/L as follows: To calculate the measured concentration (C_{K1}) in ppmv-C, the measured concentration (Y_{K1}) in ug/L must be converted from sampling units are representing the

$$Y_{K1} = (P / (R \cdot T)) (MW/a) C_{K1} \quad (3-4)$$

where P is pressure (atm), R is Rydberg's gas constant (L·atm/mole·K), T is the flux chamber air temperature (K) (Section 3.5.4.5), MW is the species' molecular weight (g/mole), a is the number of moles of carbon per mole, C_{K1} is the measured concentration of sampled unit 1 in zone K (ppmv-C), and Y_{K1} is the measured concentration of sampled unit 1 in zone K (ug/L).

The emission rate for point 1 in zone K (E_{K1}) is then calculated using the converted gas concentration (ug/L) as follows:

$$E_{KI} = (Q \cdot Y_{KI}) / A \quad (3-5)$$

where Q is the flux chamber sweep air flow rate (L/min), A is the enclosed surface area measured (m^2), and E_{KI} is the emission rate measured for point I in zone K ($ug/m^2 \cdot min$).

Prior to calculating a mean emission rate for the zone measured, the emission rates measured for the individual sampling points need to be corrected for fluctuations in chamber air the temperature (i.e., atmosphere temperature).

The approach used to develop the correction procedure involved developing an empirical equation to predict emission rates as a function of chamber air temperature. (4) The resulting emission rate equation was then used to define the correction factor (C), as follows:

$$C = EF_s / EF_a \quad (3-6)$$

where: EF_s = emission factor calculated at the nominal chamber air temperature (Section 3.5.4.5)
 EF_a = emission factor calculated at the measured chamber air temperature

Both EF_s and EF_a are predicted using the proper chamber air temperatures and the following equation:

$$EF_{(s \text{ or } a)} = \exp [0.013(TEMP_{(s \text{ or } a)})] \quad (3-7)$$

where $TEMP$ is measured in $^{\circ}C$.

The measured emission rate (E_{KI}) is then corrected to the nominal emission rate (E_{cKI}) accordingly:

$$E_{cKI} = C \cdot E_{KI} \quad (3-8)$$

The above procedure has a significance level (i.e., probability that the correlation between chamber air temperature and emission rate measured is due to chance) of 0.4 percent. The standard error of the coefficient in Equation 3-7 is ± 0.003 .

The mean emission rate for each zone is then calculated accordingly:

$$\bar{E}_K = \frac{1}{n_K} \sum_{I=1}^{n_K} E_{cKI} \quad (3-9)$$

where E_{cKI} is the temperature corrected emission rates (Equation 3-8) and n_K is the number of points sampled in zone K (Section 3.5.4.7).

For each zone (K) sampled, the zone variance (S_K^2) and coefficient of variance (CV_K) must be determined as follows:

$$S_K^2 = \frac{1}{n_K - 1} \left[\sum_{i=1}^{n_K} (E_{CKi})^2 - n_K \bar{E}_K^2 \right] \quad (3-10)$$

$$CV_K = 100 \cdot S_K / \bar{E}_K \quad (3-11)$$

where n_K , E_{CKi} , and \bar{E}_K are defined in Equations 3-3, 3-8, and 3-9, respectively. The standard deviation (S_K) should be calculated for $n_K - 1$ degrees of freedom for populations (n_K) less than or equal to 30. Larger sample sizes require n_K degrees of freedom.

Prior to calculating the overall emission rate that represents all the zones measured, the data must be tested for level of confidence. That is, for the given coefficient of variance (CV_K) of zone K, the zone sample size (n_K) must be equal to or greater than the sample size required (N_K), listed in Table 3-3, to estimate the overall emission rate with 95 percent confidence that the estimate will be within 20 percent of the true mean.

Table 3-3 lists sample sizes required for 95 percent confidence and a 20 percent confidence interval. The total number of samples (N_K) to be collected for different levels of confidences are calculated accordingly:

$$N_K \geq \frac{t_{\alpha}^2 CV_K^2}{p^2} \quad (3-12)$$

where a study requires $100(1 - 2\alpha)$ percent confidence that the emission rate estimates will be within p percent of the true mean. The parameter t_{α} is the $(1 - \alpha)$ percentage point of a student's t -distribution with N_K degrees of freedom. A table of t -values can be found in any book on standard statistical techniques. Recommended values for t_{α} are listed in Table 3-4.

Use Table 3-3 and CV_K to determine the total number of samples (N_K) required from a given zone. If $N_K > n_K$, then $N_K - n_K$ additional samples must be collected from zone K.

Collect any additional samples and recalculate the emission estimates for the zone mean (\bar{E}_K) and variance (S_K^2) using Equations 3-9 and 3-10, respectively. If $N_K - n_K$ additional samples were collected, then use N_K samples instead of n_K in the recalculations. The overall area source mean emission rate (\bar{E}) is then calculated as follows:

$$\bar{E} = \frac{\gamma}{\sum_{K=1}^Y W_K} \bar{E}_K \quad (3-13)$$

where \bar{E}_K is defined by Equation 3-9, W_K is the fraction of site covered by zone K (zone area/site area) and γ is the total number of zones sampled.

Finally, calculate the variance of the overall area source mean (S^2) and the confidence intervals for each zone K (CI_K) and area source (CI) emission rate mean as follows:

$$S^2 = \sqrt{\sum_{K=1}^Y W_K^2 \cdot S_K^2 / N_K} \quad (3-14)$$

$$CI_K = \bar{E}_K \pm t_{0.025} \sqrt{S_K^2 / N_K} \quad (3-15)$$

$$CI = \bar{E} \pm t_{0.025} \cdot S \quad (3-16)$$

SECTION 4

CASE STUDY

To supplement the protocol presented in Section 3, a case study will be reviewed. This study will illustrate an actual application of the protocol. Calculations and pertinent decisions will be presented.

The site, referred to as the Bonifay Spill Site, was the scene of an accidental spill of 5500 gallons of JP-4 aviation fuel. The spill site occurred near the intersection of two roads. The majority of the contaminated soil was excavated. The residual product extended over two areas, 30 feet of unvegetated right-of-way along the highway and into a pine forest containing dense underbrush.

The free surface of the water table was three feet below the land surface. The thickness of the unconsolidated sediments that comprised the water table aquifer at the site ranged from 20 to 50 feet. The state aquifer overlaid this sediment layer. Contamination of the free water table surface was expected since it was only 3 feet below landsurface. However, the state aquifer was not considered threatened due to the contaminants net upward hydraulic gradient.

A preliminary survey was performed to define the contaminated area. A series of ten borings indicated that the contaminants had percolated downward to the capillary fringe and moved laterally down gradient. A lens of product several inches thick was detected at a depth of seven feet below land surface. The estimated extent of contamination at the time of the survey study was 7,000 square feet (Figure 4-1).

Results from a preliminary emissions survey performed with a portable real-time analyzer (organic vapor analyzer) held a few inches above ground were used to divide the area source into emission zones for gridding purposes. The survey indicated only one zone was present, and the site was gridded accordingly. The field data for the survey is shown in Table 4-1. The grid system used is shown in Figure 4-2.

Surface emission measurements were made initially at eight sampling grid points. The protocol, at that time, called for the minimum number of sampling points per zone, n_k , to be selected according to the following equation (note, this equation has since been changed to Equation 3-3).

$$n_k \geq 6 + 0.1 \sqrt{\text{zone area (m}^2\text{)}}$$

FIGURE 4-1
 SCHEMATIC DIAGRAM OF BONIFAY SPILL SITE, MONITOR WELLS, AND
 EXPLORATORY BORINGS (BROWN AND KIRKNER, INC., 1983)

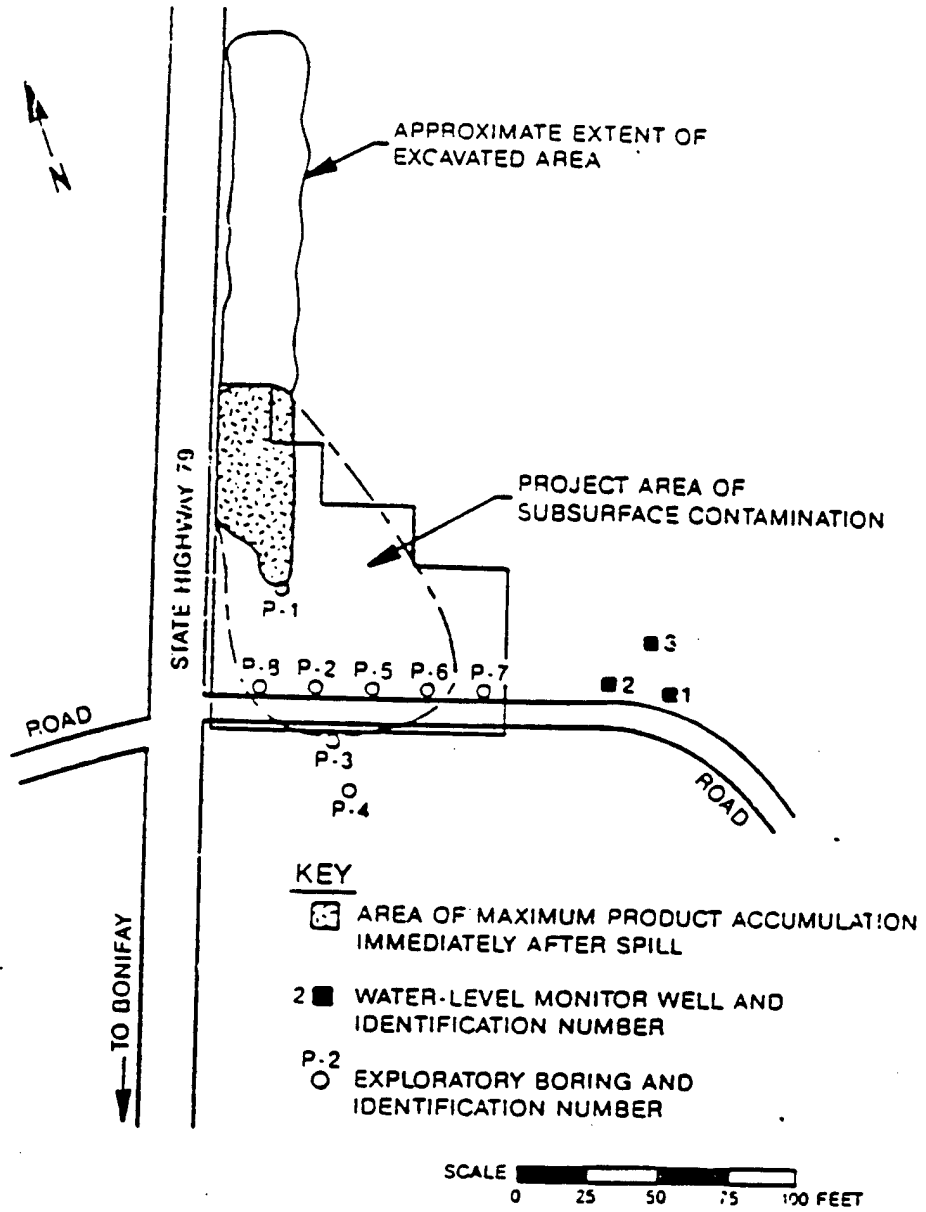

70A434

TABLE 4-1
FIELD DATA SHEET FOR UNDISTURBED SURFACE SURVEY

Operator: BME Date: 1-12-84

Weather: Temperature = 45°F. Light breeze. partly cloudy

Grid Point	Surface Temperature	Air Temperature	GC-PID		Comment
			Peak (ppmv)	Average (ppmv)	
01	40-42	45°F		0.10	Sampler was 2"-6" above soil surface
02				0.10	
04				0.10	
08				0.10	
14				0.10	
20				0.10-0.12	
21				0.10-0.12	
22				0.10-0.12	
23				0.10-0.12	
24				0.10-0.12	
25				0.10-0.12	
16				0.10	
18				0.10	
19				0.10	
Well P-3				5-6	
Well P-4			25	7	
Well P-7				40-70	
Well P-7				65	

Measurement on 1/14/84
(with GC-FID)

Comments: Survey done at Midday. Results indicate only one zone

FIGURE 4-2
 SCHEMATIC DIAGRAM OF SAMPLING GRID AT BONIFAY SPILL SITE

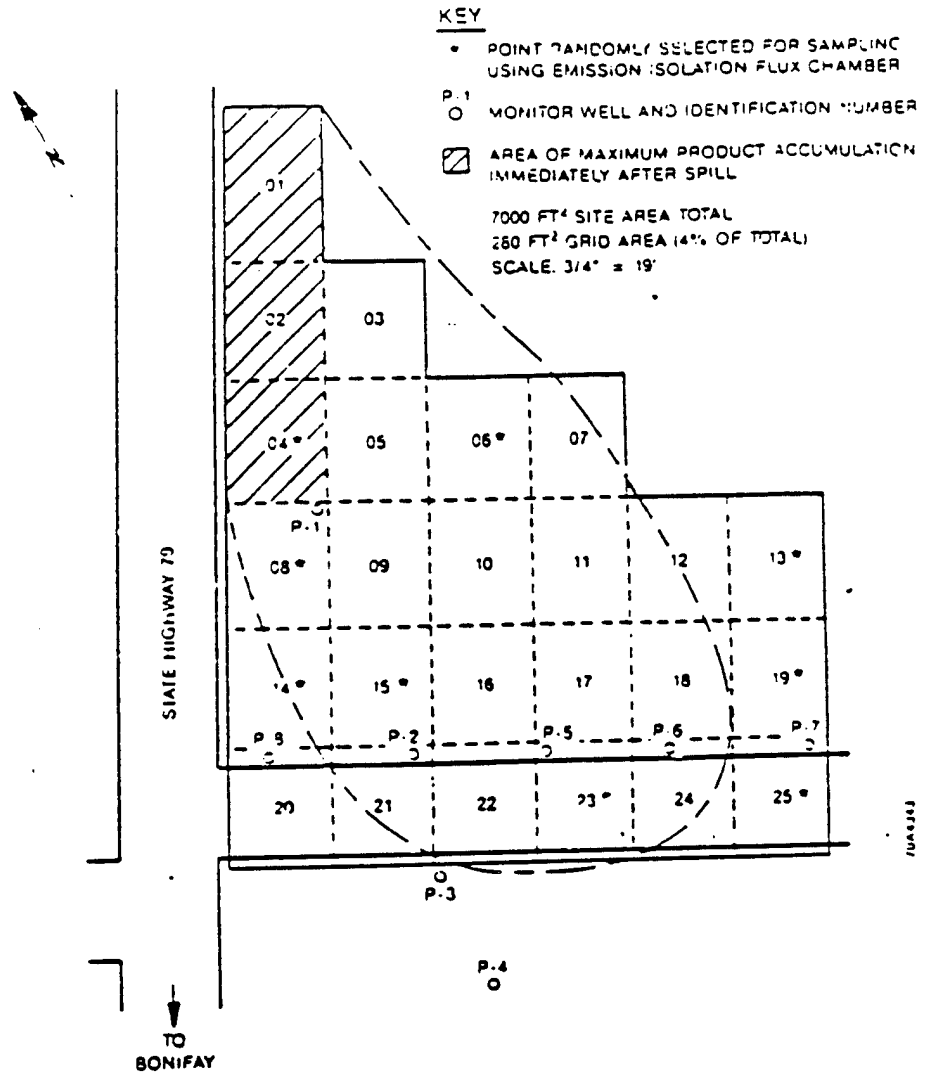

For the single zone at Bonifay, this reduced to:

$$n_K \geq 6 + 0.1 \sqrt{650 \text{ m}^2} = 8.5$$

The 8 locations were selected through the use of a random number table, Appendix A. Grid point 08 was selected to be the control point (i.e., a sampling point to be repeated each day) since it was believed that emissions would be of the largest magnitude at that location. At each sampling location a gas syringe sample was taken for on-site analysis. At several sampling locations, a gas canister was collected in addition to the syringe samples for off-site detailed analysis. A sample field data sheet is shown in Figure 4-3. The results of the emission rate measurement are given in Table 4-2, and a sample calculation is given in Table 4-3.

Total non-methane emission rates were calculated for each grid point based on the on-site analytical data. These emission rates are also presented in Table 4-2. The variation (spatially and temporally) in measured emission rates over the extent of the contaminated area was large (93.8 percent coefficient of variation). Replicate sampling at the control point allowed an estimate of the emission rate temporal variability. The temporal variability was also large (96.0 percent). The major contributor to the variation in measured emission rates from point-to-point can, therefore, be attributed to day-to-day (temporal) variability. The spatial variability was then estimated to be negligible. Using Table 3-3 to determine the total number (N_K) of samples to be collected based upon the spatial variability shows that at least 17 samples should have been collected. Although additional samples were required to be collected, sampling was terminated due to rain. It was realized that the lack of a complete data set would then result in a larger emission rate confidence interval.

Using the following equation, the 95 percent confidence interval (CI) for the zone emission rate was estimated.

$$CI = ER \pm t_{0.025} \sqrt{s^2/N_K}$$

where ER is the mean emission rate of the zone, s^2 is the zone variance, N_K is the total number of sites sampled, and $t_{0.025}$ is obtained from Table 3-4. The 95 percent confidence interval for the zone emission rate is from 11.3 ug/min·m² to 55.2 ug/min·m².

FIGURE 4-3
FIELD DATA SHEET FOR ISOLATION FLUX CHAMBER SAMPLING AT GRID POINT 08

Date 1-13-84 Samplers BME
 Location Sonitay Spill Site, Grid Point 08
 Concurrent Activity None
 Surface Description Sand

Time	Purge Air or Flowrate	Residence Time Number (τ)	Temp. °F		Gas Data		Air Sample Number
			Surface	Air	OVA ppmv	HNU ppmv	
0858	4.86 L/min	0	46	43	-	0.15	
0902	4.86 L/min	1			-	0.16	
0906	4.86 L/min	2			-	0.16	
0910	4.86 L/min	3			4.0	0.16	
0914	4.86 L/min	4			4.0	-	
0913	4.86 L/min	5			-	-	Canister 3003
0933	4.86 L/min	9			4.0	0.16	Gas Syringe 3002

Comments OVA background = 4 ppm. Some trouble with syringe needle plugging

TABLE 4-2
RESULTS OF GC ANALYSIS OF GAS SYRINGE TAKEN DURING FLUX CHAMBER SAMPLING

Grid Point	Sample No.	Date	Total NMHC Syringe		Sweep Air Rate (L/min)	Atmospheric Temperature		Average Emission Rate ($\mu\text{g}/\text{m}^2 \cdot \text{min}$)
			(ppmv-C)	($\mu\text{g}/\text{L}$)		$^{\circ}\text{F}$	$^{\circ}\text{C}$	
4	B004	1/13/84	1.0	0.62	2.60	47	8.3	14.4
6	B017-A	1/14/84	6.8	4.2	2.60	51*	10.6	72.6
8	B001	1/12/84	2.0	1.2	5.00	42	5.5	79.6
8	B002	1/13/84	1.0	0.62	4.86	48	8.9	24.9
8	B016	1/14/84	1.0	0.62	2.60	52	11.1	10.0
14	B006	1/13/84	1.0	0.62	2.60	45	7.2	16.6
15	B013	1/13/84	1.0	0.62	2.60	51	10.6	10.7
19	B009	1/13/84	1.0	0.62	2.60	51	10.6	10.7
23	B011	1/13/84	1.0	0.62	2.60	50	10.0	11.5
25	B008	1/13/84	8.8	5.4	2.60	53	11.7	81.4

4-7

Variability	
Spatial and Temporal:	
Mean	33.24
Standard Deviation	31.17
CV(%)	93.8
Temporal: (Control Point 8)	
Mean	38.2
Standard Deviation	36.6
CV(%)	96.0

*Surface temperature used rather than the chamber air temperature due to a large temperature differential not present in the other measurements. This is suggestive of an error in chamber air temperature measurement.

TABLE 4-3
 SAMPLE CALCULATIONS OF THE EMISSION RATE FOR GRID POINT 09 ON 1/13/84

Concentration Conversion:

$$Y_i = (P/(R \cdot T))(MW/a)(C_i) \quad \text{(Equation 3-4)}$$

where: $P = 1 \text{ atm}$
 $R = 0.08205 \text{ L} \cdot \text{atm}/\text{mole} \cdot \text{K}$
 $T = 282.6\text{K}$ (average area site air temperature)
 $MW = 86.18 \text{ g}/\text{mole}$ (referenced to hexane)
 $a = 6 \text{ moles of carbon}/\text{mole of hexane}$
 $C_i = 1.0 \text{ ppmv-C}$

$$Y_i = \frac{1 \text{ atm}}{(0.08205 \text{ L} \cdot \text{atm}/\text{mole} \cdot \text{K})(282.6\text{K})} \times \frac{86.18 \text{ g}/\text{mole}}{6 \text{ mole C}/\text{mole}} \times 1.0 \text{ ppmv-C}$$

$$Y_i = 0.6194 \text{ ug/L}$$

Emission Rate (uncorrected)

$$E_i = (Q \cdot Y_i)/A \quad \text{(Equation 3-5)}$$

where: $Q = 4.86 \text{ L}/\text{min}$
 $Y_i = 0.6194 \text{ ug}/\text{L}$
 $A = 0.130 \text{ m}^2$

$$E_i = \frac{4.86 \text{ l}/\text{min} \cdot 0.6194 \text{ ug}/\text{L}}{0.130 \text{ m}^2}$$

$$E_i = 23.15 \text{ ug}/\text{min} \cdot \text{m}^2$$

Emission Rate Correction Factor

$$EF_S = \exp[0.13(\text{TEMP}_S)] \quad \text{(Equation 3-7)}$$

where: $\text{TEMP}_S = 9.45^\circ\text{C}$ (nominal chamber air temperature $^\circ\text{C}$)
 $EF_S = \text{emission factor at nominal chamber air temperature}$

$$EF_S = \exp(0.13 \cdot 9.45)$$

$$EF_S = 3.416$$

(Continued)

TABLE 4-3
(Continued)

$$EF_a = \exp[0.13(\text{TEMP}_a)]$$

where: $\text{TEMP}_a = 8.9^\circ\text{C}$ (measured chamber air temperature $^\circ\text{C}$)
 EF_a = emission factor at the measured chamber air temperature.

$$EF_a = \exp(0.13 \cdot 8.9)$$
$$EF_a = 3.180$$

$$C = EF_s / EF_a \quad \text{(Equation 3-5)}$$
$$C = 3.416 / 3.180$$
$$C = 1.074$$

Emission Rate (corrected for temperature variation)

$$E_{cl} = C \cdot E_1 \quad \text{(Equation 3-8)}$$
$$E_{cl} = 1.074 \cdot 23.15 \text{ ug/min} \cdot \text{m}^2$$
$$= 24.86$$
$$= 24.9 \text{ ug/min} \cdot \text{m}^2$$

SECTION 5

ADDITIONAL INFORMATION

For further information on vapor/liquid equilibria (VLE) for organic systems, the following reference is suggested. The intent of this bibliography was to provide a ready listing of the references for data on VLE.

Nelson, T.P., N.P. Meserole, Annotated Bibliography of Published Material on Vapor/Liquid Equilibria. EPA, July 1983.

For further information on the selection of the flux chamber enclosure method for direct measurement of gas emission rates from contaminated soils and/or groundwater, the following reference is suggested.

Radian Corporation. Soil Gas Sampling Techniques of Chemicals for Exposure Assessment, Interim Report. EPA Contract No. 68-02-3513, Work Assignment 32, August 1983.

For further information on the actual field applications of this technique, the following references are suggested:

Radian Corporation, Soil Gas Sampling Techniques of Chemicals for Exposure Assessment: Tustin Spill Site Data Volume. EPA Contract No. 68-02-3513, Work Assignment 32. July 27, 1984.

Radian Corporation, Soil Gas Sampling Techniques of Chemicals for Exposure Assessment, Bonifay Spill Site Data Volume. EPA Contract No. 68-02-3513, Work Assignment 32. 1984.

For further information on the validation of the flux chamber technique for emission rate measurements on soil surfaces, the following reference is suggested:

Klenbusch, M.R., D. Ranum, Validation of Flux Chamber Emission Measurements on Soil Surfaces. EPA Contract No. 68-02-3889, Work Assignment 18, December 1985.

For information concerning the emission process including diffusion and adsorption, the following reference is suggested:

Manos, C.G., Jr., Effects of Clay Mineral Organic Matter Complexes on VOC Adsorption, Draft Report. EPA Contract No. 68-02-3889, Work Assignment 18, October 3, 1985.

Radian Corporation. Soil Gas Sampling Techniques of Chemicals for Exposure Assessment; Laboratory Study of Emission Rates from Soil Columns, Draft Final Report. EPA Contract No. 68-02-3513, Work Assignment 32, October 1984.

REFERENCES

1. Farmer, W.J., M.S. Yang, and J. Letoy. Land Disposal of Hexachloro-benzene Wastes--Controlling Vapor Movement in Soil. EPA-600/2-80-119, Municipal Environmental Research Laboratory, Cincinnati, Ohio, August 1981.
2. Shen, T.T. Estimating Hazardous Air Emissions from Disposal Sites, Pollution Engineering, August 1981.
3. U.S. EPA, Office of Solid Waste. Guidance Document for Subpart F, Air Emission Monitoring, Land Disposal Toxic Air Emissions Evaluation Guideline. December 1980.
4. Kienbusch, M.R., D. Ranum. Validation of Flux Chamber Emission Measurements on Soil Surfaces. EPA, EMSL, Contract No. 68-02-3889, Work Assignment 18, December 1985.
5. Radlen Corporation, Soil Gas Sampling Techniques of Chemicals for Exposure Assessment, Interim Report, EPA Contract No. 68-02-3513, Work Assignment 32, U.S. EPA EMSL, EAD, August 1983.
6. Adams, D.F., M.R. Pack, W.L. Barnesberger, and A.E. Sherrard, "Measurement of Biogenic Sulfur-Containing Gas Emissions from Soils and Vegetation." In: Proceedings of 71st Annual APCA Meeting, Houston, TX, 1978, p. 78-76.
7. Adams, D.F., Sulfur Gas Emissions from Flue Gas Desulfurization Sludge Ponds. J. Air Pol. Contr. Assoc. Vol. 29, No. 9, p. 963-968, 1979.
8. Dermead, O.T. Chamber Systems for Measuring Nitrous Oxide Emission from Soils in the Field. Soil Sciences Soc. of Am. J., 43, p. 89-95, 1979.
9. Balfour, W.D. and C.E. Schmidt, Sampling Approaches for Measuring Emission Rates from Hazardous Waste Disposal Facilities. In: Proceedings of 77th Annual Meeting of the Air Pollution Control Association, San Francisco, California, June 1984.
10. Zimmerman, P. Procedures for Conducting Hydrocarbon Emission Inventories of Biogenic Sources and Some Results of Recent Investigations. In: Proceedings of 1977 Environmental Protection Agency Emission Inventory/Factor Workshop, Raleigh, NC, 1977.

APPENDIX A

SELECTION OF A RANDOM SAMPLE

An illustration of the method of use of tables of random numbers follows. Suppose the population consists of 87 items, and we wish to select a random sample of 10. Assign to each individual a separate two-digit number between 00 and 86. In a table of random numbers, pick an arbitrary starting place and decide upon the direction of reading the numbers. Any direction may be used, provided the rule is fixed in advance and is independent of the numbers occurring. Read two-digit numbers from the table, and select for the sample those individuals whose numbers occur until 10 individuals have been selected. For example, in Table A-1, start with the second page of the table, column 20, line 6, and read down. The 10 items picked for the sample would thus be numbers 38, 44, 13, 73, 39, 41, 35, 07, 14, and 47.

The method described is applicable for obtaining simple random samples from any sampled population consisting of a finite set of individuals. In the case of an infinite sampled population for the target population of weighings as comprising all weighings which might conceptually have been made during the time while weighing was done. We cannot, by mechanical randomization, draw a random sample from this population, and so must recognize that we have a random sample only by assumption. This assumption will be warranted if previous data indicate that the weighing procedure is in a state of statistical control; unwarranted if the contrary is indicated; and a leap in the dark if no previous data are available.

TABLE A-1
SHORT TABLE OF RANDOM NUMBERS

46	24	45	77	27	92	36	26	45	21	39	91	71	42	64	64	53	22	75	31	74	51	45	46	18
44	19	15	32	53	55	37	77	33	29	45	00	31	34	44	95	72	50	44	27	78	22	07	62	17
74	19	40	62	24	33	31	67	28	11	74	79	26	35	34	23	09	94	00	30	55	31	53	27	91
74	97	50	30	65	07	71	30	01	84	47	45	39	70	74	13	04	90	51	27	61	34	53	57	44
22	14	61	60	86	38	33	71	13	33	72	08	16	13	50	56	48	51	29	48	30	93	45	46	29
40	03	96	40	03	47	24	60	09	21	21	18	00	05	86	52	35	40	73	73	57	58	36	33	91
52	33	76	44	36	15	47	75	78	73	78	19	37	06	98	47	48	02	62	03	42	05	12	55	02
37	59	20	40	93	17	82	24	19	90	30	37	32	71	59	84	24	49	79	17	23	75	53	42	00
11	02	55	57	48	34	74	36	22	67	19	20	15	92	53	37	13	75	54	39	56	73	23	19	07
10	13	79	26	34	54	71	33	89	74	68	48	23	17	49	18	31	05	52	35	70	05	73	11	17
67	59	28	25	47	89	11	65	65	20	42	23	96	41	64	20	30	39	87	64	37	93	36	96	35
93	50	75	20	09	18	54	34	68	02	54	67	23	05	43	36	98	29	97	93	87	08	30	92	98
24	43	23	72	30	64	34	27	23	46	15	36	10	63	21	59	69	76	02	62	31	62	47	50	34
39	91	63	18	38	27	10	78	38	84	42	32	00	97	92	00	04	94	50	05	75	42	70	30	35
74	62	19	67	54	18	28	92	33	69	98	96	74	35	72	11	68	25	08	95	31	79	11	79	54
91	03	35	60	81	16	61	97	25	14	78	21	22	05	25	47	26	37	50	39	19	06	41	02	90
42	57	66	75	72	91	03	63	48	46	44	01	33	53	62	25	30	59	55	05	02	16	13	17	54
06	16	63	06	15	03	72	38	01	58	25	37	66	48	56	19	56	41	29	28	76	45	74	39	50
92	70	96	70	89	90	87	14	25	49	25	94	62	78	26	15	41	39	48	75	64	69	61	06	38
91	08	38	53	52	13	04	32	23	00	26	36	47	44	04	08	84	80	07	44	76	51	52	41	39
58	35	97	74	47	53	90	05	90	94	87	48	25	01	11	05	45	11	43	15	60	40	31	94	59
59	54	13	09	13	80	42	23	63	03	24	64	12	43	28	10	01	65	62	07	79	83	05	59	61
19	18	32	69	33	46	58	19	34	03	59	28	97	31	02	65	47	47	70	39	74	17	30	22	55
47	43	31	09	12	60	19	57	53	78	11	30	10	77	15	70	04	39	81	78	54	84	47	33	42
61	75	37	19	56	90	75	39	03	56	49	92	72	95	27	52	87	47	12	52	54	62	43	23	13
78	19	91	11	00	63	19	63	74	58	69	03	51	38	60	36	53	56	77	06	69	03	59	91	24
93	23	71	58	09	78	08	03	07	71	79	32	25	19	61	04	40	33	12	06	78	91	37	38	95
37	55	48	82	63	89	92	39	14	72	19	17	22	51	90	20	03	64	96	60	48	01	95	44	34
62	13	11	71	17	23	29	25	13	85	33	35	07	69	15	68	57	92	57	11	94	44	01	33	66
29	69	97	47	03	13	20	86	22	45	59	98	64	53	39	64	94	31	55	37	73	31	58	46	42
16	94	35	82	39	07	17	30	29	89	89	90	98	36	25	36	53	02	49	14	34	03	52	09	20
04	93	10	59	75	12	28	84	60	93	68	16	87	60	11	50	46	56	58	45	98	72	50	46	11
95	71	43	68	57	18	85	17	13	08	00	50	77	50	46	92	45	26	97	21	48	22	23	08	32
96	05	79	14	35	48	68	18	36	57	09	62	40	28	87	08	74	79	91	08	27	12	43	32	03
50	30	60	10	41	31	00	69	63	77	01	89	94	60	19	02	70	88	72	33	38	88	20	60	46
05	45	35	40	54	03	98	96	76	27	77	54	80	08	64	60	44	34	54	24	85	20	55	77	32
71	35	17	74	66	27	35	19	55	56	51	36	48	92	32	44	40	47	10	38	22	52	42	29	96
80	20	32	50	98	00	40	92	57	51	32	33	14	55	31	99	73	23	40	07	64	54	44	99	21
13	50	78	02	73	39	56	92	01	28	67	51	75	66	33	97	47	58	42	44	88	09	28	58	06
67	92	65	41	45	36	77	96	46	21	14	33	56	36	70	15	74	43	62	69	82	30	77	25	77
72	56	73	44	26	04	62	81	15	35	79	26	99	57	28	22	25	94	80	62	95	48	98	23	86
28	86	35	64	94	11	58	78	45	36	34	45	91	38	51	10	58	76	57	81	16	77	30	19	36
59	57	40	50	44	94	60	92	94	93	98	01	48	50	57	69	60	77	69	60	74	22	05	77	17
71	20	03	30	79	25	74	17	78	34	54	45	04	77	42	59	75	78	64	99	37	03	18	03	36
49	98	55	98	22	45	12	49	82	71	57	33	28	69	50	59	15	09	25	79	39	42	44	18	70
58	74	82	81	14	02	01	05	77	94	65	57	70	39	42	48	56	94	31	59	18	70	41	74	90
50	54	73	81	91	07	31	26	25	45	49	61	22	88	41	20	00	15	59	93	51	60	65	65	63
49	13	72	90	10	20	65	28	44	63	95	56	75	78	69	24	41	65	96	10	34	10	32	00	93
11	35	01	43	65	02	85	69	56	58	74	29	64	75	48	15	70	11	77	33	01	34	32	91	04
14	22	46	41	84	74	27	02	57	77	47	93	72	02	95	63	75	74	69	59	61	34	31	92	13

TABLE A-1
(CONTINUED)

05	57	23	06	26	23	08	66	16	11	75	28	81	56	14	62	82	45	65	80	36	02	76	55	63
37	75	16	06	57	12	46	22	90	97	75	67	39	06	63	60	51	02	07	16	75	12	90	41	16
23	71	15	08	82	64	87	29	01	20	46	72	05	30	19	27	47	15	76	51	58	67	06	90	76
42	67	98	41	67	44	28	71	45	08	19	47	76	30	26	72	33	69	92	51	95	23	26	87	76
05	83	03	34	32	62	83	27	18	83	09	19	84	90	20	20	50	87	74	93	51	62	10	23	30
60	46	18	41	23	74	73	51	72	90	40	52	95	41	20	89	48	98	27	38	81	33	53	82	94
32	30	64	75	91	98	09	40	64	89	29	99	46	35	69	91	50	73	75	92	90	56	82	93	24
79	86	53	77	78	06	62	37	48	82	71	00	78	21	65	65	88	45	82	44	78	93	22	78	09
45	13	23	32	01	09	46	36	43	66	37	15	35	04	88	79	83	53	19	13	91	59	81	81	87
20	60	97	48	21	41	84	22	72	77	99	81	83	30	46	15	90	26	51	73	66	34	99	40	60
67	91	44	83	43	25	56	33	28	80	99	53	27	56	19	80	76	32	53	95	07	53	09	61	98
86	50	76	93	86	35	58	45	37	83	47	44	92	57	66	59	64	16	48	39	26	94	54	66	40
66	73	38	38	23	36	10	95	16	01	10	01	59	71	55	99	24	88	31	41	00	73	13	80	62
55	11	50	29	17	73	97	04	20	39	20	22	71	11	43	00	15	10	12	35	09	11	00	89	05
23	54	33	87	92	92	04	49	73	96	57	53	57	08	93	09	69	87	83	07	46	39	50	37	65
41	48	67	79	44	57	40	29	10	34	58	63	51	18	07	41	02	39	79	14	40	68	10	01	61
03	97	71	72	43	27	36	24	59	88	52	37	26	31	11	44	28	58	99	47	83	21	35	22	88
90	24	83	48	07	41	56	68	11	14	77	75	48	68	08	90	89	63	87	00	06	18	63	21	91
98	98	97	42	27	11	80	51	13	03	42	91	14	51	22	15	48	67	52	09	40	34	60	85	85
74	20	94	21	49	96	51	69	99	85	43	76	55	81	36	11	88	68	32	43	08	14	78	05	34
94	67	48	87	11	84	00	85	93	56	43	99	21	74	84	13	56	41	90	96	30	04	19	68	73
58	18	84	82	71	23	66	33	19	25	65	17	90	84	24	91	75	38	14	83	86	22	70	86	99
31	47	25	24	88	49	28	69	78	62	23	45	53	38	78	65	97	44	91	93	91	62	76	09	20
45	62	31	06	70	92	73	27	83	57	15	64	40	57	58	54	42	35	43	93	55	82	08	78	87
31	49	87	12	27	41	07	91	72	64	63	42	06	66	82	71	28	36	45	31	99	01	03	35	76
69	37	22	23	46	10	75	83	62	54	44	65	46	23	65	71	69	20	89	12	16	56	61	70	41
93	67	21	56	78	42	52	53	14	86	24	70	25	18	23	23	56	24	03	86	11	06	46	10	23
77	56	18	37	01	32	20	18	70	79	20	85	77	89	28	17	77	15	52	47	15	30	35	12	75
37	07	47	79	60	75	24	15	31	63	25	93	27	66	19	53	52	49	98	45	12	12	06	00	32
72	08	71	01	73	46	39	60	37	58	22	25	20	84	30	02	03	62	68	58	33	04	06	89	94
55	22	48	46	72	50	14	24	47	67	84	37	32	84	82	64	97	13	69	86	20	09	80	46	75
63	24	98	90	70	29	34	25	33	23	12	69	90	50	38	93	84	32	28	96	03	65	70	90	12
01	86	77	18	21	91	66	11	84	65	48	75	26	94	51	40	51	53	36	39	77	69	06	25	07
51	40	94	06	80	61	34	28	46	28	11	48	48	94	60	65	06	63	71	06	19	35	05	32	56
58	78	02	85	80	29	67	27	44	07	67	23	20	28	22	62	97	59	62	13	41	72	70	71	07
33	75	88	51	00	33	56	15	84	34	28	50	18	65	12	81	56	43	54	14	63	37	74	97	59
58	60	37	45	62	09	95	93	16	59	35	22	91	78	04	97	98	80	20	04	38	93	13	92	30
72	13	12	95	32	87	99	32	82	65	40	17	92	57	22	68	98	79	16	23	53	56	56	07	47
22	21	13	16	10	52	57	71	40	49	95	25	55	36	95	57	25	25	77	05	38	05	62	57	77
97	94	83	67	90	65	74	88	17	22	38	01	04	33	49	38	47	57	61	87	15	39	43	87	00
09	03	68	53	63	29	27	31	66	57	39	34	88	87	04	35	80	69	52	74	99	16	52	01	65
29	95	61	42	65	05	72	27	25	14	09	85	24	59	46	03	91	55	38	62	51	71	47	37	38
81	96	78	90	47	41	38	36	33	95	05	90	28	72	85	23	23	30	70	51	56	93	23	84	90
44	62	20	81	21	57	57	85	00	47	26	10	87	22	45	72	03	51	75	23	38	38	56	77	97
68	91	12	15	08	02	18	74	56	79	21	53	63	41	77	15	07	39	87	11	19	25	62	19	30
29	33	77	60	29	09	25	09	42	28	07	15	40	67	56	29	58	75	84	06	19	54	31	16	53
54	13	39	19	29	64	97	73	71	61	78	03	24	02	93	86	69	76	74	28	08	98	84	08	23
75	16	55	64	64	93	85	68	08	84	15	41	57	84	45	11	70	13	17	60	47	80	10	13	00
36	47	17	08	79	03	92	85	18	42	95	48	27	37	99	98	81	94	44	72	06	95	42	31	17
29	61	08	21	91	23	76	72	84	98	26	23	66	54	86	88	95	14	82	57	17	99	16	28	99

TABLE A-1
(CONTINUED)

03	46	35	56	84	81	20	59	68	52	45	41	01	71	55	14	18	05	15	01	74	94	50	56	07
74	12	14	57	26	12	48	33	67	04	88	69	05	27	23	68	54	23	32	07	21	67	13	52	01
08	23	73	51	23	92	93	05	54	32	84	46	61	33	92	13	50	91	73	11	30	44	21	71	20
99	21	30	24	79	30	18	06	96	20	62	06	47	96	07	04	32	33	01	56	62	70	3	21	85
96	82	59	39	23	22	20	95	72	00	24	85	63	57	75	88	05	79	13	75	78	64	25	89	55
62	15	18	23	64	50	90	57	50	54	04	96	09	08	17	14	63	17	80	80	56	10	17	11	57
21	40	82	41	45	41	41	39	46	18	55	36	94	32	57	44	12	64	75	12	78	01	13	69	81
13	43	48	32	60	78	96	30	57	13	40	28	10	24	48	73	50	92	70	13	72	86	54	09	76
29	6	33	93	52	99	26	01	86	11	95	42	48	36	59	24	96	35	07	87	67	31	25	99	62
17	49	05	12	13	52	01	98	80	17	83	35	38	14	79	52	36	44	51	35	40	70	68	27	27
14	38	47	29	15	14	22	27	62	93	15	60	43	13	05	25	75	40	08	55	44	70	89	64	13
78	09	76	61	07	48	31	27	48	28	96	11	28	95	03	06	96	81	52	72	68	74	71	60	25
83	17	94	28	39	01	48	68	56	97	05	76	82	89	15	66	81	63	81	96	12	44	71	57	43
87	12	89	46	85	58	09	94	39	92	09	08	76	54	38	82	73	24	94	39	02	79	07	58	27
44	30	30	40	85	96	34	99	87	03	93	03	00	74	18	67	13	97	11	12	59	30	54	51	66
54	56	95	50	81	32	42	53	60	36	98	03	65	10	60	26	52	64	74	35	28	13	24	65	23
65	99	30	88	88	44	91	22	50	72	61	95	90	98	80	65	03	45	04	27	58	70	88	40	49
55	56	01	94	09	94	02	71	85	10	27	20	51	27	36	09	15	11	62	41	03	22	82	10	60
55	78	53	40	57	16	20	17	73	02	76	09	62	95	95	67	75	45	99	63	39	55	88	27	99
33	78	98	57	23	38	95	61	06	58	69	07	35	82	10	35	61	61	66	06	75	45	83	33	70
20	14	56	25	85	78	33	37	34	15	50	63	78	74	56	49	94	72	58	00	93	68	11	47	46
48	04	07	78	13	43	03	62	46	20	06	94	09	27	69	00	71	51	43	84	21	12	96	03	51
61	10	14	39	57	87	76	60	77	02	06	50	15	60	46	22	27	52	87	43	69	58	65	79	02
64	91	38	96	42	22	57	18	13	44	46	81	95	15	37	91	81	63	33	38	39	50	47	46	94
89	53	11	10	33	10	46	41	63	84	20	46	86	41	05	82	95	56	76	23	33	13	94	28	49
96	45	86	42	40	85	95	17	28	74	65	20	70	90	34	33	61	11	01	31	37	28	81	00	31
84	11	25	39	49	31	80	86	53	51	35	48	22	28	25	27	06	38	71	90	50	77	47	41	58
29	75	56	28	39	23	26	12	23	48	89	28	34	08	52	21	05	73	08	04	83	42	91	01	91
58	92	40	32	19	49	20	85	32	69	34	17	99	11	56	39	15	67	55	53	65	29	15	51	32
94	19	67	99	27	70	71	04	43	18	44	18	75	11	70	53	21	60	78	30	92	54	21	02	42
84	84	68	46	85	58	91	23	65	24	71	19	67	18	79	90	83	47	86	32	48	69	97	10	97
63	22	84	35	10	02	05	03	47	93	45	70	25	27	90	32	98	41	45	96	39	86	91	78	79
42	53	20	46	19	11	16	93	21	93	14	91	74	92	11	97	58	24	20	35	19	54	75	37	84
37	90	76	51	58	49	25	58	28	69	55	55	73	10	22	66	79	23	30	03	51	11	00	81	37
20	12	97	40	25	45	94	35	18	65	10	99	31	24	42	14	53	78	41	79	36	57	79	19	76
24	11	65	19	92	46	11	76	64	37	33	23	96	23	73	93	99	53	14	49	40	01	63	17	74
98	21	62	16	29	73	52	06	26	35	30	52	74	61	20	57	45	86	36	54	75	29	64	49	43
02	82	14	07	19	72	77	97	39	77	25	32	60	39	04	04	88	65	47	20	81	72	40	65	48
97	20	87	54	01	93	38	53	07	38	61	00	22	95	65	79	59	28	90	49	24	61	78	19	40
17	84	31	34	32	29	40	23	66	71	14	91	93	75	02	10	13	86	27	32	59	36	40	06	61
75	50	70	16	34	21	99	87	09	37	27	40	66	07	73	13	44	06	10	43	91	11	73	13	97
47	53	77	58	88	52	47	37	21	60	83	58	21	59	82	58	05	35	17	68	33	62	15	09	88
20	93	99	76	58	93	00	39	77	75	59	39	49	61	13	68	11	80	07	72	81	65	95	94	53
91	02	65	18	16	57	93	64	76	45	21	49	51	58	96	12	62	42	10	79	57	44	97	35	66
58	49	25	97	76	12	90	94	85	25	36	40	97	46	71	83	36	55	41	38	49	98	82	70	96
98	51	20	13	77	75	86	22	62	68	36	87	02	47	99	68	30	27	34	10	09	22	54	59	33
05	32	54	17	31	87	20	77	78	80	98	42	48	42	47	41	76	11	41	79	41	48	26	94	59
40	96	49	91	79	57	18	61	50	48	06	07	68	43	07	01	04	06	22	03	11	11	75	95	02
58	43	93	93	53	01	61	75	76	90	25	97	08	76	69	35	65	24	83	85	00	49	37	05	46
76	98	86	43	60	47	85	65	73	62	66	15	98	17	20	43	96	27	87	53	57	37	92	86	16

TABLE A-1
(CONTINUED)

24	81	06	14	98	24	93	38	63	66	58	26	24	45	65	91	42	68	67	42	61	74	77	93	46
75	55	34	29	67	02	81	01	67	34	08	31	31	00	79	62	38	52	14	58	38	66	59	41	97
49	71	80	34	37	73	34	11	74	14	91	36	82	41	02	76	12	36	71	38	43	72	94	36	27
04	19	48	35	54	98	00	41	47	44	63	13	27	50	18	75	16	72	40	90	02	45	87	82	15
66	15	52	42	22	91	22	96	38	41	03	27	15	67	26	36	81	75	11	82	94	33	62	08	94
10	90	17	67	83	05	31	23	08	07	40	00	60	44	65	70	16	31	73	05	46	41	47	64	63
40	42	27	55	76	82	88	42	76	51	58	49	58	75	38	23	57	06	64	69	46	90	09	55	68
95	57	21	21	25	12	05	41	70	23	03	39	97	37	64	48	69	48	59	60	89	76	35	83	05
57	27	64	94	92	88	93	70	86	39	46	84	08	32	31	75	61	19	49	11	28	46	76	79	28
80	56	69	49	63	83	78	78	76	36	89	51	16	47	35	86	69	96	69	88	91	22	47	24	84
44	51	75	51	08	17	43	53	31	09	60	34	34	61	93	68	01	94	37	13	24	09	75	29	21
55	42	48	76	50	13	89	69	00	05	99	45	82	01	53	88	68	81	36	50	75	20	17	94	47
80	50	67	83	01	97	76	21	64	34	62	43	02	84	38	13	60	26	32	36	51	43	17	56	41
03	64	65	44	02	75	41	33	91	28	82	97	57	38	49	27	26	97	34	44	26	12	00	68	24
14	23	75	37	91	43	95	15	13	26	33	27	45	48	33	80	80	25	69	76	04	87	83	58	32
01	64	43	36	30	71	24	75	92	73	07	81	13	35	46	88	62	80	64	59	86	25	73	92	98
39	38	79	42	17	77	99	55	32	85	13	35	48	49	80	83	59	06	34	94	06	03	61	85	02
74	96	24	94	89	54	66	29	75	58	50	46	65	50	26	62	45	80	61	55	07	99	57	10	54
21	16	54	55	77	46	38	33	88	55	21	56	18	93	32	94	24	80	97	03	78	39	73	87	70
58	51	99	53	96	73	60	77	21	06	76	59	78	55	96	99	07	53	91	95	99	60	56	61	79
46	98	27	95	19	22	25	41	56	76	83	48	49	82	79	79	20	00	26	40	22	50	14	30	73
58	46	36	76	19	19	00	60	50	23	32	44	18	35	99	28	91	50	53	62	21	61	26	46	81
43	05	50	00	20	39	25	46	84	39	27	39	92	42	59	04	64	15	09	35	07	11	25	51	17
84	07	33	83	87	14	33	79	07	66	60	43	66	57	57	59	01	78	80	13	77	63	58	10	
93	54	23	72	70	09	36	16	24	04	74	05	65	29	64	67	37	28	13	98	01	48	29	75	89
54	46	72	02	34	52	81	38	52	96	14	54	27	32	41	74	84	83	90	01	97	59	87	66	41
43	60	84	28	32	93	91	76	70	31	50	22	09	40	89	64	85	82	76	91	16	71	99	98	70
64	80	90	16	92	46	42	46	47	22	87	16	20	65	82	01	45	21	49	80	17	39	70	74	03
72	70	39	30	06	59	65	14	84	04	82	28	46	64	05	89	81	80	09	89	56	11	27	81	44
14	88	67	03	59	32	15	83	04	01	20	82	92	25	34	88	84	80	76	69	25	10	04	86	02
69	28	06	18	56	78	97	49	14	85	01	58	31	16	20	53	74	03	27	05	80	39	15	67	49
99	68	09	96	36	54	10	77	95	88	90	84	52	16	52	58	87	51	31	71	68	53	11	85	50
01	66	27	15	54	63	83	64	15	30	21	86	48	17	11	68	92	16	17	49	36	05	17	80	24
67	85	26	91	23	14	28	01	76	47	65	12	58	24	27	61	59	43	20	15	93	47	30	56	27
13	91	16	76	91	97	85	48	99	50	40	96	30	68	97	82	66	06	90	97	65	28	44	98	08
95	82	20	95	52	65	95	03	48	75	64	25	04	13	85	80	13	37	08	18	09	28	63	07	69
44	06	82	49	28	27	34	53	42	35	44	12	40	64	35	06	28	14	37	23	97	38	07	60	80
99	22	26	64	15	71	06	96	22	93	77	46	73	57	51	22	54	82	37	99	96	27	25	87	77
08	44	26	12	87	72	42	13	57	77	61	07	94	24	62	17	76	19	45	18	98	11	47	40	31
14	96	76	06	37	32	09	72	81	22	87	70	81	93	78	93	37	22	32	25	38	45	38	03	31
27	36	41	53	58	16	49	99	19	03	62	98	79	81	98	15	03	62	32	93	68	24	14	44	50
99	67	81	61	25	52	97	87	98	15	85	99	01	86	59	00	11	39	32	53	49	18	62	51	65
89	14	37	94	03	22	32	45	42	61	97	83	04	28	30	48	49	40	99	99	69	96	13	94	21
34	13	53	15	32	42	02	58	32	14	83	73	02	82	49	25	62	91	14	94	70	72	64	50	51
72	11	79	75	79	36	07	12	92	61	89	93	77	82	08	23	74	75	67	56	37	45	35	13	44
19	72	57	61	99	08	62	02	25	82	32	90	72	51	94	84	59	79	34	19	95	76	21	49	91
96	99	76	63	90	27	60	94	15	70	17	74	92	21	85	24	47	55	64	51	91	47	13	39	69
44	15	86	76	18	15	57	29	51	52	95	84	20	83	01	11	90	66	80	81	40	43	65	87	35
33	83	94	07	50	18	89	86	16	50	09	97	04	76	51	41	20	56	50	20	33	53	70	10	22
53	07	06	16	30	84	43	40	37	32	18	09	47	16	69	41	03	38	24	02	16	41	58	39	58

APPENDIX H
INJECTION WELL OPERATING PERMIT APPLICATION

 **Lockheed**
Aeronautical Systems Company

A Division of Lockheed Corporation
Marietta, Georgia 30063-0440

John K. Giles
Director of
Safety and Environmental

October 12, 1993

Georgia Geologic Survey
Environmental Protection Division
Georgia Department of Natural Resources
Room 400
19 MLK, Jr. Drive, S.W.
Atlanta, Georgia 30334

Attn: Permit Application Department

Subject: INJECTION WELL OPERATING PERMIT APPLICATION FOR BIOVENTING
PROJECT AT LOCKHEED AERONAUTICAL SYSTEMS COMPANY (LASC),
MARIETTA, GEORGIA

Dear Sir:

LASC, in conjunction with the Air Force and Engineering Science, is attempting to initiate a pilot bioventing program to remediate an existing JP-5 fuel spill site. Basically, the procedure involves pumping ambient air into the ground through a PVC well to stimulate subsurface biological activity, which in turn will accelerate the bacterial consumption of the existing petroleum hydrocarbons in the soil.

It is our understanding that the Georgia Geologic Survey, in the realm of injection well requirements, considers air to be a liquid and liquids require an injection well permit. Therefore, we are submitting the enclosed injection well operating permit application. Please review this application at your earliest convenience, as we are anxious to commence with the remediation project.

If you have any questions or require additional information, please contact Richard Rexrode at 494-2417.

Sincerely,

LOCKHEED AERONAUTICAL SYSTEMS COMPANY

J. K. Giles

JKG:RTR:lh
RTR195 #

Enclosure

STATE OF GEORGIA
DEPARTMENT OF NATURAL RESOURCES
ENVIRONMENTAL PROTECTION DIVISION
GEORGIA GEOLOGIC SURVEY

INJECTION WELL OPERATING PERMIT APPLICATION

REGULATORY
AGENCY:

Georgia Geologic Survey Branch
Environmental Protection Division
Georgia Department of Natural Resources
Room 400
19 Martin Luther King Jr. Dr. S.W.
Atlanta, Georgia 30334

LEGAL

AUTHORITY: Water Quality Control Act
OCGA 12-5-20 et. seq.

FACILITY DATA

Lockheed Aeronautical Systems Company - Georgia

Business/Corporate Name

86 South Cobb Drive

Street

City

County

Georgia

30063

State

Zip Code

Telephone Number

Manufacturing of Aircraft

Type of Industry

John Giles

Name of Owner or Authorized Representative

Director, Safety & Environmental

Title of Authorized Representative **Number if Different from Above**

Is the underground injection part of a corrective action or
remediation plan to be included in another EPD permit? If so, please
explain. no

INJECTION WELL DATA

Kilman Brothers Inc. - groundwater monitoring well drilling N/A
Ga. Licensed Water Well Contractor contractor Lic. Num.

P.O. Box 870013 Stone Mountain Dekalb
Street City County

GA 30087-0001 (404) 469-9080
State Zip Code Telephone Number

How many injection wells or devices does this application include?
one well to be completed in the soil (see Figure 3.5 attached)

Are the wells or devices proposed or existing? proposed

Classification of injection well(s) or devices (please circle): I
II, III, IV(prohibited), V

INJECTION WELL CONSTRUCTION

Well Depth 26 ft Borehole Dia. 12 in Csg. Depth _____

Csg. Dia. 2 in Screen Type PVC, Sch 40 Screen Dia. 2 in

Screened Interval: from 6 to 26 ft

Grouted Interval: from 0 to 2 ft Grout thick. 1 ft

Grout type: cement grout

Csg. Material (please check the material used): PVC Steel
 Polybutylene Polyethtlene Latex Fiberglass Teflon
 Other

Please provide a detailed diagram of the injection well(s) or device(s) showing the items described above.

INJECTION SYSTEM DATA

Type of Injection Fluid: ambient air

INJECTION SYSTEM DATA (CONT.)

Source of Injected Fluid: ambient air
Purpose of Injection: to supply minimum oxygen into the subsurface to sustain indigenous
Proposed Injection Rate: 30 SCFM ~~average daily gallons per minute~~ micro-organisms
Proposed Injection Volume: 43,200 SCFD ~~average daily gallons--~~
Proposed Injection Pressure: TBD* ave. daily lbs./sq. inch (psi)

Please include the following with the application:

- a. A chemical analysis of the injected fluid. The analysis must include all constituents specified in the currently applicable Georgia Rules for Safe Drinking Water. NA for ambient air
- b. A detailed diagram showing the engineering layout of the injection equipment and all piping associated with the system. Figures 3.2, 3.3, 3.4 (attached)
- c. A comprehensive subsurface report, prepared by or directly supervised by a Georgia Professional Engineer or Geologist. (attached)
- d. A letter from the applicable local government stating that the project is not inconsistent with their local land use planning or zoning requirements or that they have no applicable land use or zoning requirements. NA
- e. A detailed map orienting the injection well(s) and any other wells to two (2) nearby reference points such as roads, streams or nearby structures, etc. Please clearly mark the distances from the wells to the reference points. Figure 3.1 (attached)

The applicant specifically grants to EPD or any authorized agent of the Director the right of entry and travel upon the injection well site for the purpose of conducting necessary compliance inspections.

Certification:

I certify under the penalty of law that I have examined and am familiar with the information submitted in this document and all attachments and that, based on the inquiry of the individuals responsible for the data, I believe that the information is true, accurate and complete. I am aware that there are penalties for submitting false information, including the possibility of fine and imprisonment.

John Giles

Owner or Authorized Representative

Signature

13 Oct '93
Date Signed

Figure 3.1

PROPOSED VENT WELL AND VAPOR MONITORING POINTS
 AFP6 - JP-5 LEAK AREA

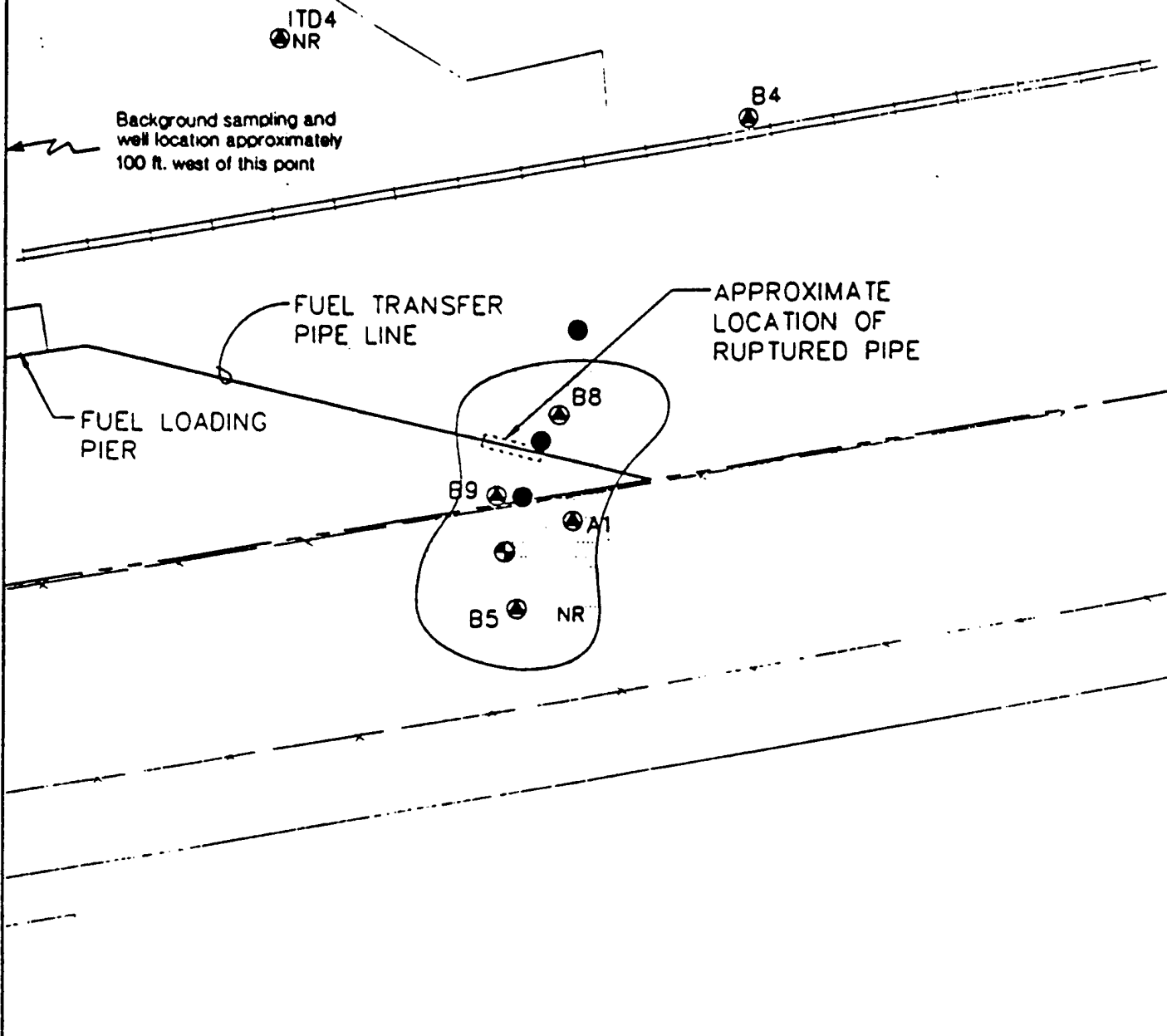

LEGEND

ITS2	MONITORING WELL IDENTIFICATION, APPROXIMATE LOCATION.		BUILDING
	TREE & BRUSH		FENCE
	BOUNDARY LINE		STREAM
	IMPROVED ROAD		RAILROAD
	UNIMPROVED ROAD	ITD3 NR	SAMPLE COLLECTION NOT REQUIRED AT THE MONITORING WELL
	VENT WELL (VW)		EXTENT OF SURFACE FUEL CONTAMINATION
	VAPOR MONITORING POINT (VMP) SET AT 15', 30' AND 60' FROM VW		

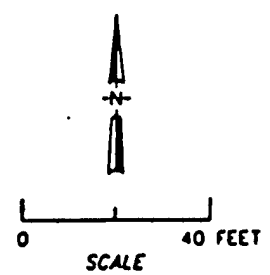

N:\DE268\CADD\SITE-1. 06/04/93 at 17:17

INJECTION VENTING WELL CONSTRUCTION DETAIL Air Force Plant 6, Georgia

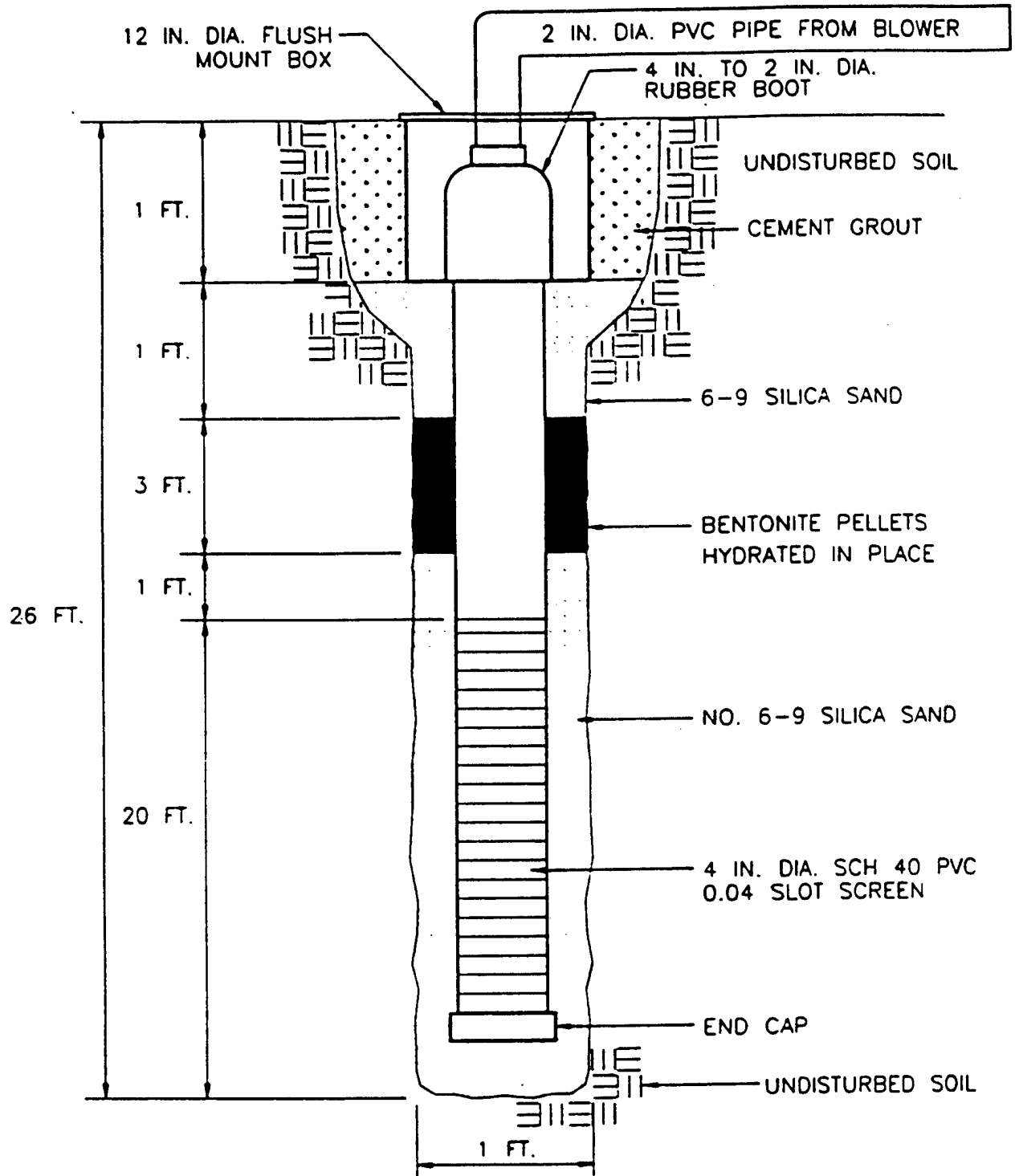

N:\AT808\CADD\WELL-1. 06/04/93 at 13:35

Not To Scale

TYPICAL MONITORING POINT CONSTRUCTION DETAIL

Air Force Plant 6, Georgia

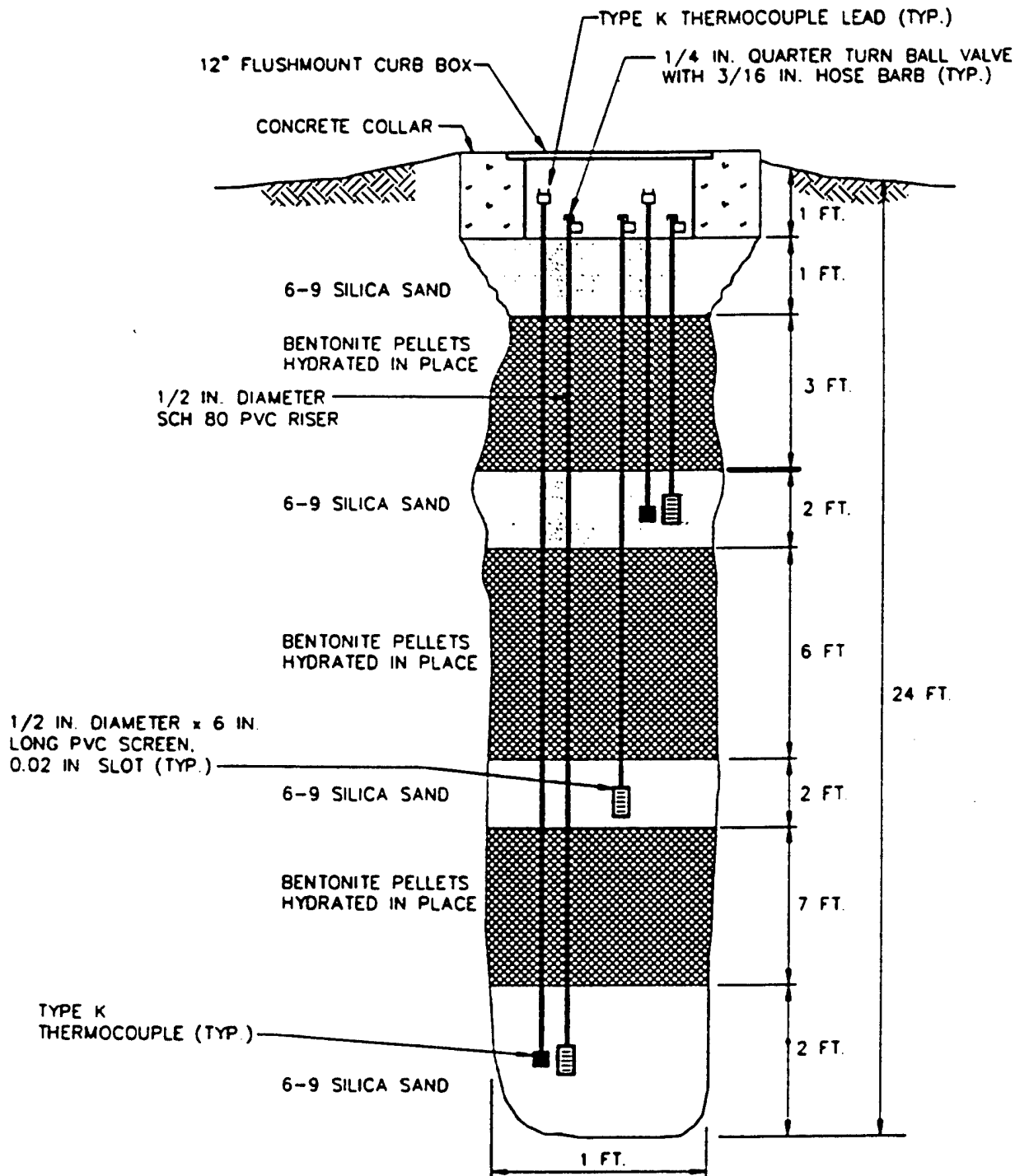

NOT TO SCALE

N:\AT808\CADD\WELL2. 06/04/93 at 13:47

SCHEMATIC OF BLOWER SYSTEM FOR AIR INJECTION
JP-5 LEAK AREA
 AIR FORCE PLANT 6, GEORGIA

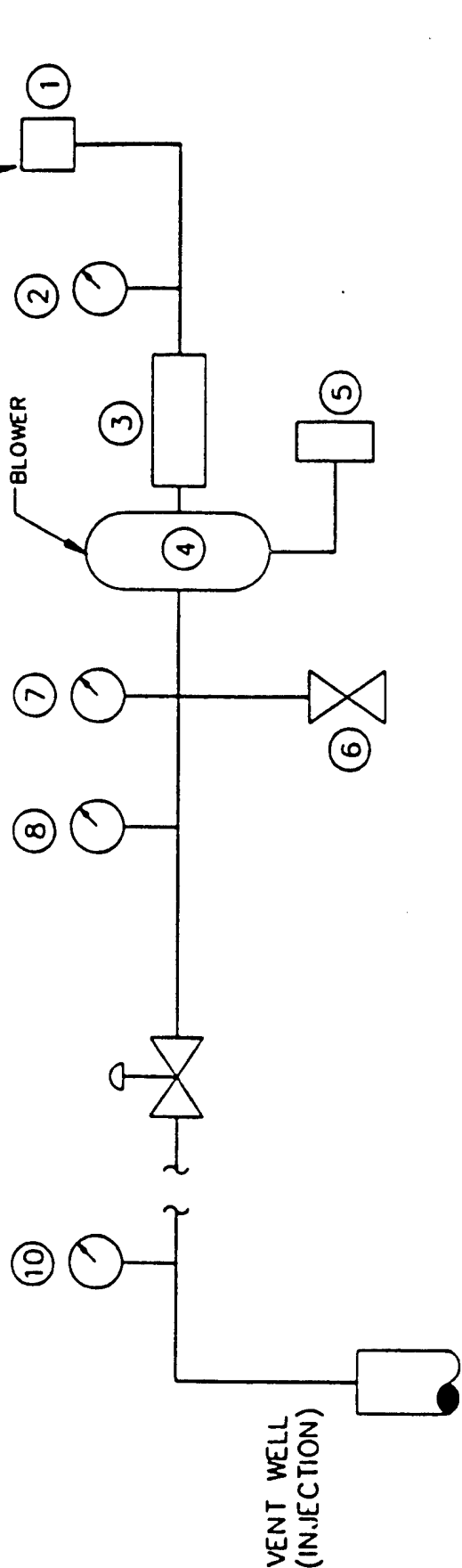

- ① INLET FILTER
- ② VACUUM GAUGE (INCHES OF H O)
- ③ DRIVE MOTOR
1 HP / 3450 RPM @ 60 Hz / 230v / SINGLE PHASE / 15 A
- ④ BLOWER - GAST R4110-2 / REGENERATIVE
70 SCFM @ 20 INCHES H O
- ⑤ POWER SWITCH
- ⑥ AUTOMATIC PRESSURE RELIEF VALVE - SET @ 42 INCHES H O
- ⑦ PRESSURE GAUGE (INCHES OF H O)
- ⑧ THERMOMETER (FAHRENHEIT)
- ⑨ MANUAL PRESSURE RELIEF (BLEED) VALVE - 1 1/2" BALL
- ⑩ AIR VELOCITY MEASUREMENT PORT

CONCEPTUAL CROSS-SECTION DESIGN FOR
 BIOVENTING PILOT TEST AT THE JP-5 LEAK AREA
 AF PLANT-6

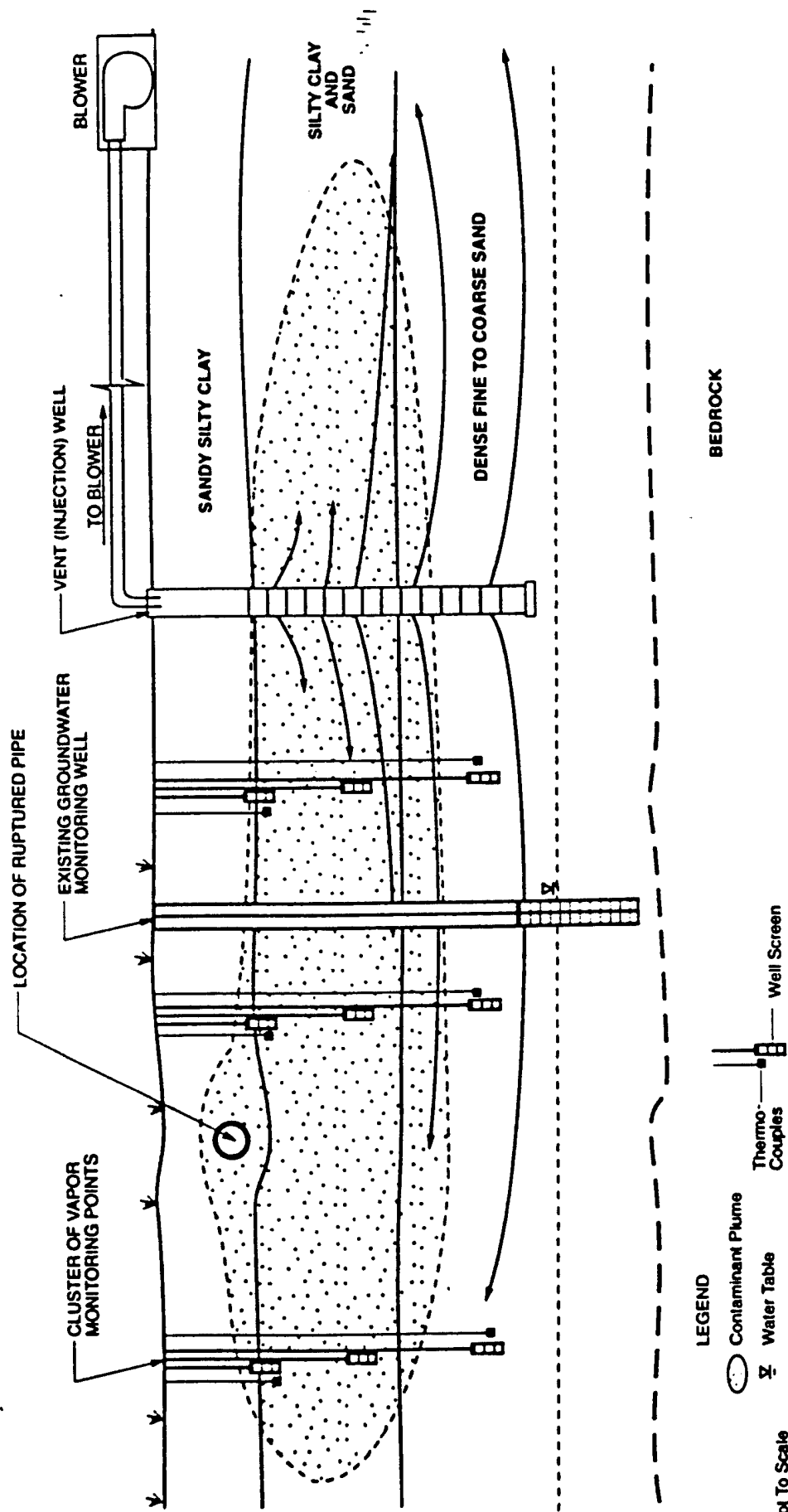

Figure 3.5

ENGINEERING-SCIENCE