

LOAN DOCUMENT

PHOTOGRAPH THIS SHEET

0

DTIC ACCESSION NUMBER

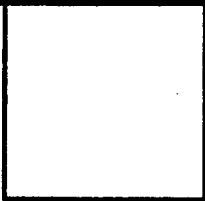

LEVEL

INVENTORY

Work Plan for a Treatability Study...

DOCUMENT IDENTIFICATION

Jan 90

DISTRIBUTION STATEMENT A
Approved for Public Release
Distribution Unlimited

DISTRIBUTION STATEMENT

ACCESSION FOR	
NTIS	GRAM
DTIC	TRAC
UNANNOUNCED	
JUSTIFICATION	
BY	
DISTRIBUTION/	
AVAILABILITY CODES	
DISTRIBUTION	AVAILABILITY AND/OR SPECIAL
A-1	

DISTRIBUTION STAMP

--

DATE ACCESSIONED

--

DATE RETURNED

20001130 044

DATE RECEIVED IN DTIC

--

REGISTERED OR CERTIFIED NUMBER

PHOTOGRAPH THIS SHEET AND RETURN TO DTIC-FDAC

H
A
N
D
L
E

W
I
T
H

C
A
R
E

**Work Plan for a
Treatability Study in Support of the
Intrinsic Remediation (Natural Attenuation) Option at
The BX Shoppette (Site E11)**



**Eaker Air Force Base
Blytheville, Arkansas**

Prepared For

**Air Force Center for Environmental Excellence
Technology Transfer Division
Brooks Air Force Base
San Antonio, Texas**

and

**Air Force Base Conversion Agency/OL-J
Eaker Air Force Base
Blytheville, Arkansas**

January 1996

AQM01-01-0358

DEFENSE TECHNICAL INFORMATION CENTER REQUEST FOR SCIENTIFIC AND TECHNICAL REPORTS

Title AFCEE Collection

1. Report Availability (Please check one box)

- This report is available. Complete sections 2a - 2f.
- This report is not available. Complete section 3.

2a. Number of Copies Forwarded

1 each

2b. Forwarding Date

July/2000

2c. Distribution Statement (Please check ONE box)

DoD Directive 5230.24, "Distribution Statements on Technical Documents," 18 Mar 87, contains seven distribution statements, as described briefly below. Technical documents MUST be assigned a distribution statement.

- DISTRIBUTION STATEMENT A: Approved for public release. Distribution is unlimited.
- DISTRIBUTION STATEMENT B: Distribution authorized to U.S. Government Agencies only.
- DISTRIBUTION STATEMENT C: Distribution authorized to U.S. Government Agencies and their contractors.
- DISTRIBUTION STATEMENT D: Distribution authorized to U.S. Department of Defense (DoD) and U.S. DoD contractors only.
- DISTRIBUTION STATEMENT E: Distribution authorized to U.S. Department of Defense (DoD) components only.
- DISTRIBUTION STATEMENT F: Further dissemination only as directed by the controlling DoD office indicated below or by higher authority.
- DISTRIBUTION STATEMENT X: Distribution authorized to U.S. Government agencies and private individuals or enterprises eligible to obtain export-controlled technical data in accordance with DoD Directive 5230.25, Withholding of Unclassified Technical Data from Public Disclosure, 6 Nov 84.

2d. Reason For the Above Distribution Statement (in accordance with DoD Directive 5230.24)

2e. Controlling Office

HQ AFCEE

2f. Date of Distribution Statement Determination

15 Nov 2000

3. This report is NOT forwarded for the following reasons. (Please check appropriate box)

- It was previously forwarded to DTIC on _____ (date) and the AD number is _____
- It will be published at a later date. Enter approximate date if known. _____
- In accordance with the provisions of DoD Directive 3200.12, the requested document is not supplied because: _____

Print or Type Name

Laura Peña

Signature

Laura Peña

Telephone

210-536-1431

(For DTIC Use Only)

AQ Number MOI-01-0358

**WORK PLAN FOR A
TREATABILITY STUDY IN SUPPORT OF
INTRINSIC REMEDIATION (NATURAL ATTENUATION)
OPTION AT THE BX SHOPPETTE (SITE E11)**

**EAKER AIR FORCE BASE
BLYTHEVILLE, ARKANSAS**

January 1996

Prepared for:

**AIR FORCE CENTER FOR ENVIRONMENTAL EXCELLENCE
TECHNOLOGY TRANSFER DIVISION
BROOKS AIR FORCE BASE
SAN ANTONIO, TEXAS**

and

**AIR FORCE BASE CONVERSION AGENCY/OL-J
EAKER AIR FORCE BASE
BLYTHEVILLE, ARKANSAS**

Prepared by:

**PARSONS ENGINEERING SCIENCE, INC.
1700 BROADWAY, SUITE 900
DENVER, COLORADO 80290**

TABLE OF CONTENTS

	Page
1 INTRODUCTION.....	1-1
1.1 Scope of Current Work Plan.....	1-2
1.2 Background	1-4
2 DATA REVIEW AND CONCEPTUAL MODEL DEVELOPMENT	2-1
2.1 Data Review	2-1
2.1.1 Topography, Surface Hydrology, and Climate	2-2
2.1.2 Overview of Geology and Hydrogeology	2-4
2.1.2.1 Regional Geology and Hydrogeology	2-4
2.1.2.2 BX Shoppette Geology and Hydrology	2-5
2.1.3 Summary of Analytical Data for BX Shoppette	2-13
2.1.3.1 Soil Sampling and Analytical Results	2-13
2.1.3.2 Groundwater Sampling and Analytical Results	2-18
2.1.3.3 Geochemical Indicators of BTEX Degradation.....	2-20
2.2 Development of Conceptual Site Model	2-26
2.2.1 Predicting Intrinsic Remediation with Fate and Transport Models	2-27
2.2.2 Initial Conceptual Site Model.....	2-29
2.2.3 Potential Pathways and Receptors	2-31
3 COLLECTION OF ADDITIONAL DATA	3-1
3.1 Cone Penetrometry	3-4
3.1.1 CPT/LIF Testing Strategy	3-6
3.1.2 Soil Sampling and Analysis	3-9
3.1.3 CPT Locations and Datum Survey	3-11
3.1.4 Site Restoration	3-13
3.1.5 Equipment Decontamination Procedures	3-13
3.2 Permanent Monitoring Point Installation	3-14
3.2.1 Monitoring Point Locations and Completion Intervals.....	3-14
3.2.2 Monitoring Point Installation Procedures	3-15
3.2.2.1 Pre-Placement Activities	3-16
3.2.2.2 Groundwater Monitoring Point Installation	3-16
3.2.2.3 Above-Grade and At-Grade Well Completion.....	3-17
3.2.2.4 Monitoring Point Development.....	3-17
3.2.2.5 Water Level Measurements	3-21
3.2.2.6 Monitoring Point Location and Datum Survey	3-21
3.2.3 Site Restoration	3-22

TABLE OF CONTENTS (Continued)

3.3	Groundwater Sampling	3-22
3.3.1	Groundwater Sampling Strategy	3-24
3.3.2	Preparation for Sampling	3-24
3.3.2.1	Equipment Cleaning	3-24
3.3.2.2	Equipment Calibration	3-25
3.3.3	Sampling Procedures	3-25
3.3.3.1	Preparation of Location	3-28
3.3.3.2	Water Level and Total Depth Measurements	3-28
3.3.3.3	Purging Before Sampling	3-29
3.3.3.4	Sample Extraction	3-29
3.3.4	Onsite Groundwater Parameter Measurement	3-30
3.3.4.1	Dissolved Oxygen (DO) Measurements	3-30
3.3.4.2	pH, Temperature, and Specific Conductance	3-31
3.3.4.3	Carbon Dioxide Measurements	3-31
3.3.4.4	Alkalinity Measurements	3-31
3.3.4.5	Nitrate- and Nitrite-Nitrogen Measurements	3-32
3.3.4.6	Sulfate and Sulfide Sulfur Measurements	3-32
3.3.4.7	Total Iron, Ferrous Iron, and Ferric Iron Measurements	3-32
3.3.4.8	Manganese Measurements	3-33
3.3.4.9	Reduction/Oxidation Potential	3-33
3.3.5	Handling of Samples for Laboratory Analysis	3-34
3.3.5.1	Sample Preservation	3-34
3.3.5.2	Sample Container and Labels	3-34
3.3.5.3	Sample Shipment	3-35
3.3.5.4	Chain-of-Custody Control	3-35
3.3.5.5	Sampling Records	3-36
3.3.6	Laboratory Analyses	3-38
3.4	Aquifer Testing	3-38
3.4.1	Definitions	3-39
3.4.2	Equipment	3-40
3.4.3	General Test Methods	3-40
3.4.4	Falling Head Test	3-41
3.4.5	Rising Head Test	3-44
3.4.6	Slug Test Data Analysis	3-44
4	REMEDIAL OPTION EVALUATION AND TS REPORT	4-1
5	QUALITY ASSURANCE/QUALITY CONTROL	5-1
6	REFERENCES	6-1

TABLE OF CONTENTS (Continued)

APPENDIX A CONTAINERS, PRESERVATIVES, PACKAGING,
AND SHIPPING REQUIREMENTS FOR
GROUNDWATER SAMPLES

APPENDIX B ADDITIONAL SITE DATA

LIST OF TABLES

<u>No.</u>	<u>Title</u>	<u>Page</u>
2.1	Summary of Well Completion Data	2-11
2.2	Summary of Soil Analytical Data	2-14
2.3	Summary of Groundwater Analytical Data	2-19
2.4	Summary of Groundwater Geochemical Data	2-23
3.1	Analytical Protocol for Groundwater and Soil Samples	3-3
4.1	Example TS Report Outline.....	4-3
5.1	QA/QC Sampling Program	5-2

LIST OF FIGURES

<u>No.</u>	<u>Title</u>	<u>Page</u>
1.1	Base Location.....	1-5
1.2	BX Shoppette Location	1-6
1.3	BX Shoppette Site	1-8
2.1	Regional Topographic Map	2-3
2.2	Hydrogeologic Cross-Section Locations	2-7
2.3	Cross-Section A-A'	2-8
2.4	Cross-Section B-B'	2-9
2.5	Groundwater Elevation Map (March 27, 1992)	2-12
2.6	Soil BTEX Contour (0-10 feet bgs) March 1991.....	2-16
2.7	Groundwater BTEX Isopleth Map August 1995	2-21
2.8	Groundwater Alkalinity Isopleth Map August 1995	2-24
2.9	Groundwater Sulfate Isopleth Map August 1995	2-25
3.1	Cross-Section of Fiber Optic Fluorometry Penetrometer.....	3-7
3.2	Proposed Soil and Groundwater Sampling Locations	3-8
3.3	Geologic Boring Log.....	3-12
3.4	Monitoring Point Installation Record	3-18
3.5	Monitoring Point Development Record.....	3-20
3.6	Groundwater Sampling Record.....	3-26
3.7	Aquifer Test Data Form	3-42

SECTION 1

INTRODUCTION

This work plan, prepared by Parsons Engineering Science, Inc. (Parsons ES), presents the scope of work required for the collection of data necessary to conduct a treatability study (TS) for remediation of groundwater contaminated with petroleum hydrocarbons at the Base Exchange (BX) Shoppette underground storage tank site (Site E11) located at Eaker Air Force Base (AFB) (the Base), near the city of Blytheville, Arkansas. Several groundwater remedial options will be evaluated as a part of the TS report, including: active bioremediation (i.e., air sparging and bioventing); groundwater extraction, treatment, and disposal (i.e., pump and treat); and natural contaminant attenuation (intrinsic remediation) with long-term monitoring. Hydrogeologic and groundwater chemical data necessary to evaluate the various remedial options will be collected under this program; however, this work plan is oriented toward the collection of hydrogeologic data to be used as input into groundwater flow and solute transport models in support of intrinsic remediation for restoration of groundwater contaminated with benzene, toluene, ethylbenzene, and xylene (BTEX).

As used in this report, the term "intrinsic remediation" refers to a management strategy that relies on natural attenuation mechanisms to remediate contaminants dissolved in groundwater and to control receptor exposure risks associated with contaminants in the subsurface. "Natural attenuation" refers to the actual physical, chemical, and biological processes that facilitate intrinsic remediation. Mechanisms for natural attenuation of BTEX include biodegradation, advection, dispersion, dilution from recharge, sorption, and volatilization. Of these processes, biodegradation is the only mechanism working to

transform contaminants into innocuous byproducts. Intrinsic bioremediation occurs when indigenous microorganisms work to bring about a reduction in the total mass of contamination in the subsurface without the addition of nutrients. Patterns and rates of intrinsic remediation can vary markedly from site to site depending on governing physical and chemical processes.

As part of the TS, the contaminant fate and transport modeling effort has three primary objectives: 1) predict the future extent and concentration of dissolved contaminant plumes by modeling the effects of advection, dispersion, sorption, and biodegradation; 2) assess the possible exposure of potential downgradient receptors to contaminant concentrations that exceed levels intended to be protective of human health and the environment; and 3) provide technical support for selection of the intrinsic remediation option as the best remedial alternative at regulatory negotiations, as appropriate. The modeling efforts for the BX Shoppette at Eaker AFB will involve completion of several tasks, which are described in the following sections.

This work plan was developed following discussions among representatives from the Air Force Center for Environmental Excellence (AFCEE), Air Force Base Conversion Agency (AFBCA), and Parsons ES at a meeting held at the Base on November 16, 1995, the statement of work (SOW) for this project, and on a review of existing site characterization data. All field work will follow the health and safety procedures presented in the program *Health and Safety Plan for Bioplume II Modeling Initiative* (Engineering Science, Inc., 1993), and the site-specific addendum to the program Health and Safety Plan. This work plan was prepared for AFCEE and AFBCA.

1.1 SCOPE OF CURRENT WORK PLAN

The ultimate objective of the work described herein is to provide a TS for remediation of hydrocarbon groundwater contamination at the BX Shoppette. However, this project is part of a larger, broad-based initiative being conducted by AFCEE in conjunction with the US Environmental Protection Agency (USEPA) and Parsons ES to document the

biodegradation and resulting attenuation of fuel hydrocarbons and solvents dissolved in groundwater, and to model this degradation using numerical and analytical groundwater model codes. For this reason, the work described in this work plan is directed toward the collection of data in support of this initiative. Data sufficient to develop a 30-percent design of an alternate groundwater remediation system, should intrinsic remediation not prove to be a viable remedial option at this facility, also will be collected under this program. This work plan describes the site characterization activities to be performed by personnel from Parsons ES in support of the TS and the groundwater modeling effort. Field activities will be performed to determine the extent of mobile and residual light nonaqueous-phase liquid (LNAPL) at the site and to determine the extent of dissolved contamination. The data collected during the TS will be used along with data from previous investigations to complete the characterization of the site. These data will also be used in the groundwater flow and solute transport models to make predictions of the future concentrations and extent of contamination.

Site characterization activities in support of the TS will include: 1) determination of preferential contaminant migration and potential receptor exposure pathways; 2) soil sampling using cone penetrometer (CPT) direct-push technology; 3) groundwater monitoring point placement; 4) groundwater sampling; and 5) aquifer testing. The materials and methodologies to accomplish these activities are described herein. Previously reported site-specific data and data collected during the supplemental site characterization activities described in this work plan will be used as input for the groundwater flow and solute transport models. Where site-specific data are not available, conservative values for the types of aquifer materials present at the site will be obtained from widely accepted published literature and used for model input. Sensitivity analyses will be conducted for the parameters that are known to have the greatest influence on the model results, and where possible, the model will be calibrated using historical site data. Upon completion of the modeling, Parsons ES will provide technical assistance at regulatory negotiations to support the intrinsic remediation option if the results of the modeling indicate that this approach is warranted. If it is shown that intrinsic remediation

is not the most appropriate remedial option, Parsons ES will recommend the most appropriate groundwater remedial technology on the basis of available data.

This work plan consists of six sections, including this introduction. Section 2 presents a review of available (previously reported) site-specific data, and conceptual models for the site. Section 3 describes the proposed sampling strategy and procedures to be used for the collection of additional site characterization data. Section 4 describes the remedial option evaluation procedure and TS report format. Section 5 describes the quality assurance/quality control (QA/QC) measures to be used during this project. Section 6 contains the references used in preparing this document. There are two appendices to this work plan. Appendix A contains a listing of containers, preservatives, packaging, and shipping requirements for soil and groundwater samples. Appendix B contains a summary of site data, including available well logs, and summaries of historical soil and groundwater analytical data from previous field investigations.

1.2 BACKGROUND

Eaker AFB is located in the northeastern corner of Arkansas, in Mississippi County, approximately 3 miles south of the Missouri state line and 11 miles east of the Tennessee state line. The Base occupies an area of approximately 3,300 acres 2 miles northwest of Blytheville, Arkansas and adjacent to the community of Gosnell (Figure 1.1). The Base is divided roughly in half by the main north/south runway (Figure 1.2). Aviation support, approximately 930 Base housing units, a hospital, and commercial facilities are located in the western portion of the Base. The eastern half of the Base is dedicated primarily to agricultural, recreational, and industrial activities. The predominant existing land use surrounding Eaker AFB is agricultural, with some residential parcels (Eaker AFB, 1992).

The Base was established in 1942 as the Blytheville Army Airfield and served as a training center until deactivation in 1945. From 1947 to 1955, the site was used for manufacturing, private housing, and as an airport. The Base was reactivated as Blytheville AFB in 1955 under the direction of the Tactical Air Command, and then

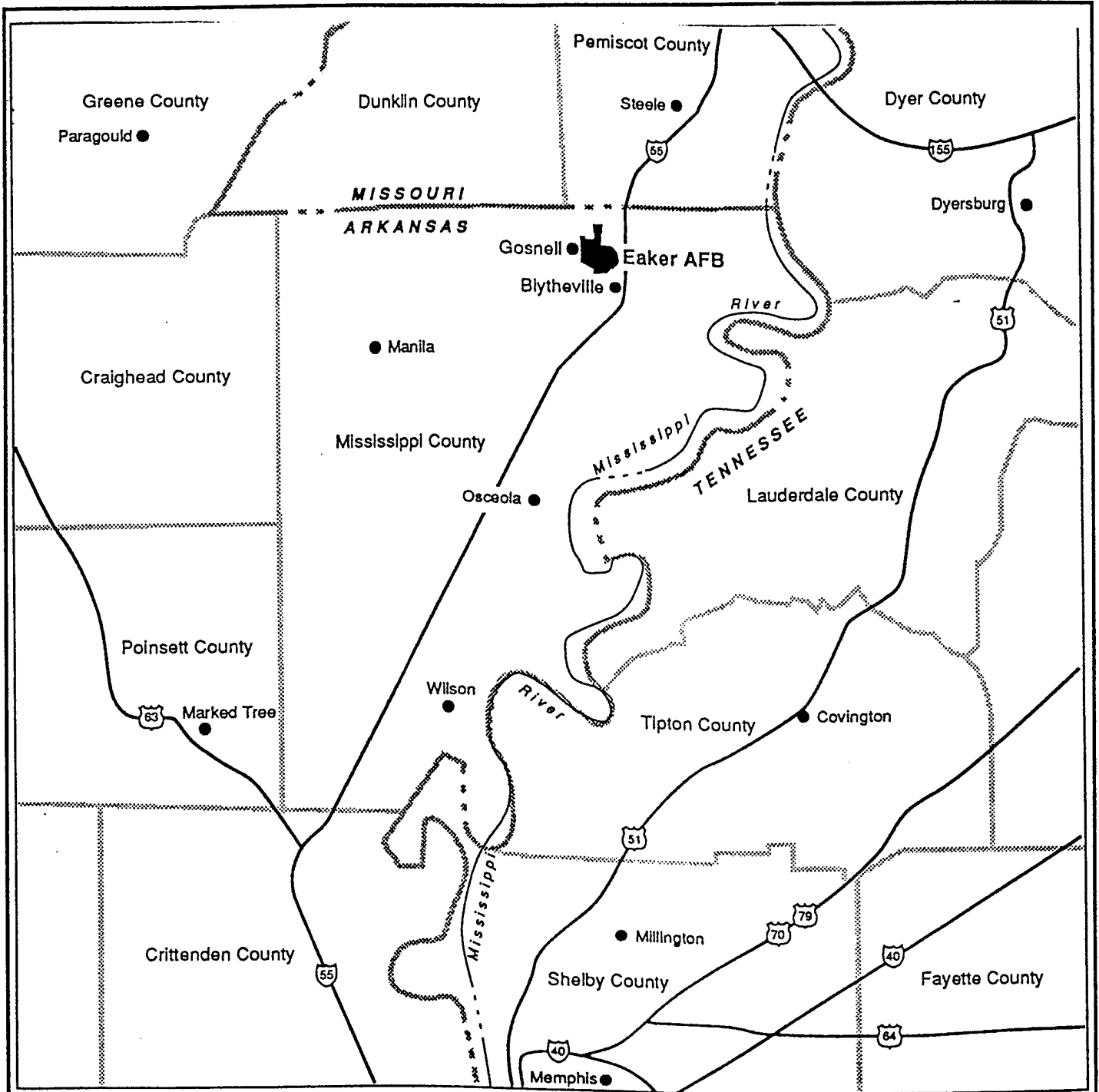

EXPLANATION

- Interstate Highway
- U. S. Highway
- State Boundary
- County Boundary
- River

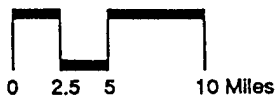

FIGURE 1.1

BASE LOCATION

BX Shoppette
 Intrinsic Remediation TS
 Eaker AFB, Arkansas



**PARSONS
 ENGINEERING SCIENCE, INC.**

Denver, Colorado

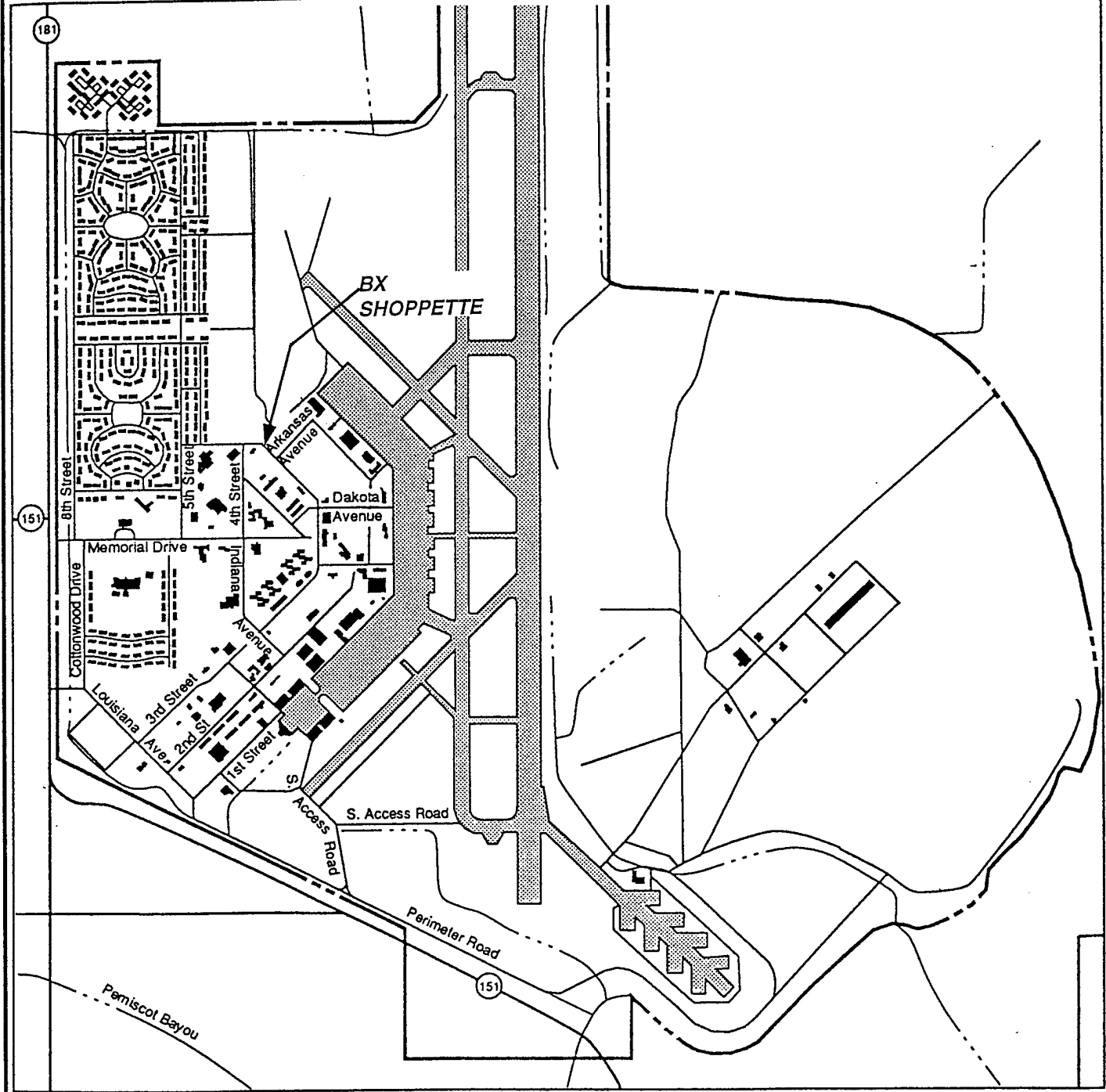
Sources: Eaker AFB, 1992.



EXPLANATION

-  Airfield Pavement
-  Base Boundary
-  Drainage



Sources: Eaker AFB, 1992.

FIGURE 1.2

**BX SHOPPETTE
LOCATION**

BX Shoppette
Intrinsic Remediation TS
Eaker AFB, Arkansas

**PARSONS
ENGINEERING SCIENCE, INC.**

Denver, Colorado

transferred to the Strategic Air Command (SAC) in 1958. The 97th Bombardment Wing assumed command of the Base until the disestablishment of SAC in 1992, when control was transferred to the Air Combat Command. In 1988, the Base was renamed Eaker AFB. Base operations in 1990 employed approximately 3,600 civilian and military personnel (Eaker AFB, 1992). In July 1991, the recommendation for base closure was approved and closure was scheduled for December, 1992.

The BX Shoppette site is located in the west-central portion of the base (Figure 1.2) and is bounded by open land to the north and west, and by base operations facilities to the east and south. Two 10,000-gallon USTs were installed at the site in 1969. The tanks (160-A and 160-B) contained regular unleaded gasoline and were steel-constructed, tar-coated, and corrosion protected by sacrificial anodes (cathodic protection). Two additional USTs (160-C and 160-D) were installed in 1971. Tank 160-C was steel-constructed, tar-coated, and cathodically protected. The tank capacity was 6,000 gallons. The tank originally contained regular leaded gasoline; however, the tank was converted to a premium unleaded gasoline tank in 1990. Tanks 160-A, -B, and -C are located within a gasoline tank pit, approximately 30 feet northwest of the BX Shoppette (Figure 1.3). Tank 160-D, a 1,000-gallon tank used to store waste oil, is located in the northeastern corner of the shoppette building (Figure 1.3). This tank is constructed of steel but is not cathodically protected (Halliburton NUS, 1994).

In 1974, a leak in the pipeline from the fuel USTs to the fuel dispensers was repaired. An unknown amount fuel was released prior to repair of the 1974 pipeline leak, and no hydrocarbon-contaminated soils were removed during the repair (Halliburton NUS, 1992). In December 1989, a tank tightness test was performed on the BX Shoppette USTs. Tank 160-A failed the tightness test and was subsequently deactivated in March 1990. In August 1990, a tank and line tightness test was performed on the remaining USTs and fuel dispensing system. This test indicated leaks in one of the 10,000-gallon USTs, the 6,000-gallon UST, and the waste oil tank. The tops of the tanks were exposed and isolated from their associated piping for retesting. All four tanks passed the retesting.





- LEGEND**
- MW1104  MONITORING WELL
 - TW1107  TEMPORARY WELL
 -  GROUNDWATER FLOW DIRECTION
 -  SURFACE DRAINAGE

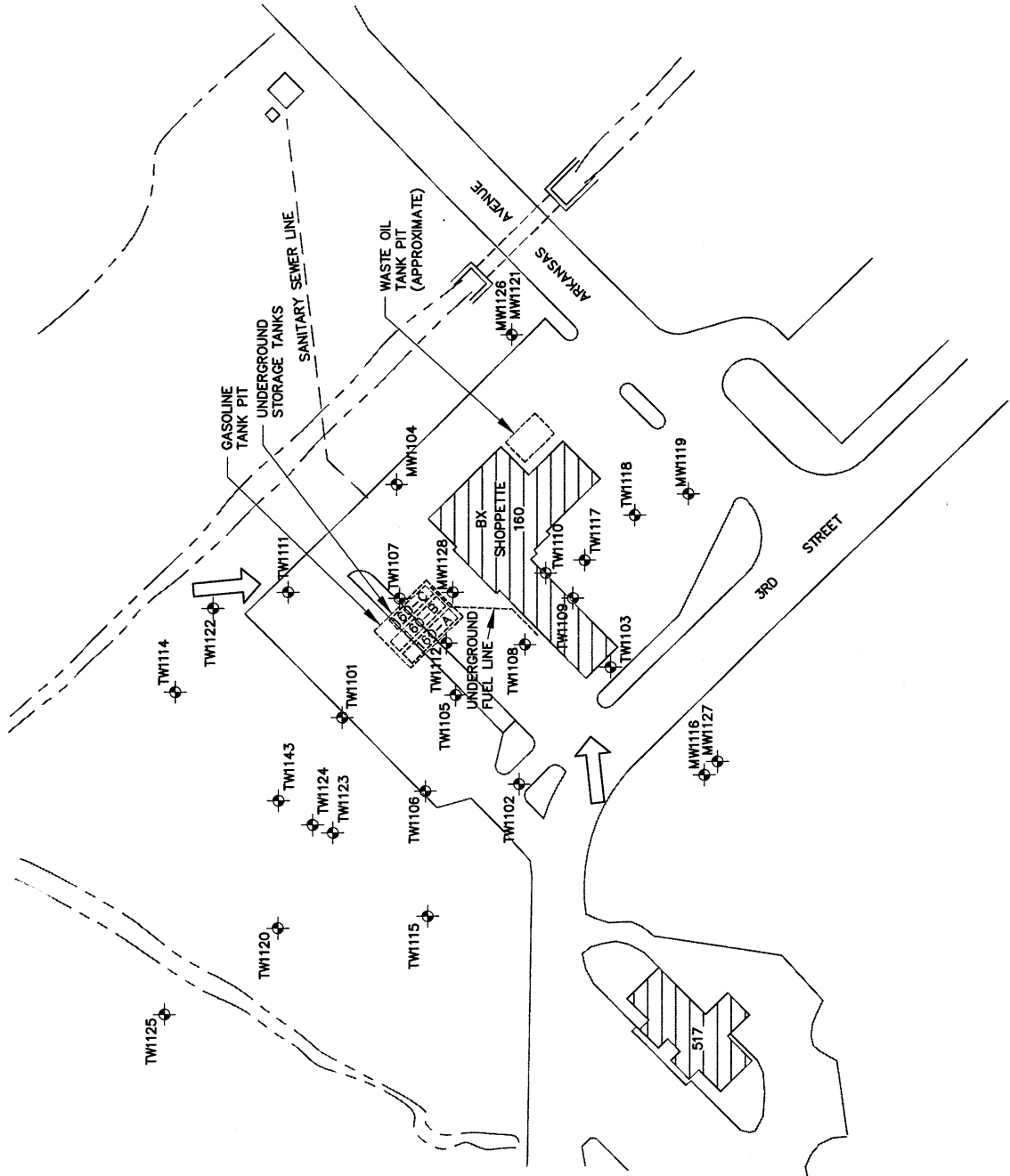

FIGURE 1.3

BX SHOPPETTE SITE

BX Shoppette
 Intrinsic Remediation TS
 Eaker AFB, Arkansas

PARSONS ENGINEERING SCIENCE, INC.
 Denver, Colorado



In February and June 1991 a total of 28 soil borings were installed by Professional Services, Inc. (PSI) (Halliburton NUS, 1992). These borings confirmed the presence hydrocarbons in the soil around the tank pit and identified free product in groundwater. Halliburton NUS (1992, 1994, and 1995) continued site investigation under the Installation Restoration Program (IRP) and collected additional soil samples, installed monitoring wells, and sampled site groundwater. The horizontal limits of soil BTEX contamination have been established, however the vertical extent of soil BTEX has not been defined. BTEX compounds have been detected in soil samples from 22 feet below ground surface (bgs) between the fuel tank pit and the BX Shoppette. Mobile LNAPL was up to 4 feet thick in an area southwest of the gasoline tank pit, as measured in May 1992. Groundwater is contaminated and may be preferentially migrating laterally along thin layers of silt and sand between clay layers. In February 1992, Eaker AFB personnel bailed a total of 10.75 gallons of free product from monitoring well TW1105. Other than this action, no product recovery has taken place (Halliburton NUS, 1994).

SECTION 2

DATA REVIEW AND CONCEPTUAL MODEL DEVELOPMENT

Previously reported site-specific data were reviewed and used to develop a conceptual site model (CSM) for the groundwater flow and contaminant transport conditions at the BX Shoppette. The CSM guides the selection of sampling locations and analytical data requirements needed to support the modeling efforts and to evaluate potential remediation technologies (including intrinsic remediation). Section 2.1 presents a synopsis of available site characterization data. Section 2.2 presents the preliminary conceptual groundwater flow and contaminant transport model that was developed based on these data.

2.1 DATA REVIEW

The following sections are based upon review of the following sources:

- *Final Environmental Impact Statement Disposal and Reuse of Eaker Air Force Base, Arkansas* (FEIS) (Eaker AFB, 1992);
- *IRP Draft Site Assessment Report for the BX Shoppette Underground Storage Tank Site* (Halliburton NUS, 1992),
- Unpublished site data (Halliburton NUS, 1994 and 1995); and

- Site Characterization and Analysis System (SCAPS) Report [US Army Corps of Engineers (USACE, 1995)].

2.1.1 Topography, Surface Hydrology, and Climate

Eaker AFB is located within the Mississippi Embayment of the Atlantic and Gulf Plains physiographic province (Eaker AFB, 1992), and lies within the eastern lowland portion of the Central Mississippi River Valley. The topography in the region is generally level except in areas adjacent to the Mississippi River. Ground surface elevations on the Base range from 245 feet above mean sea level (msl) at the southeastern end of the Base (in the vicinity of Pemiscot Bayou) to 265 feet msl at the northwestern end of the Base, near the firing range (Figure 2.1). At the BX Shoppette, the topography is flat and the ground surface elevation is approximately 250 feet msl.

Eaker AFB is located within the St. Francis River watershed of the Lower Mississippi River Basin. Surface water drainage is characteristic of the Mississippi River floodplain, and drainage ditches and bayous have been dredged in the flat terrain to accommodate surface water runoff. The majority of the Base lies above the level of the 100-year floodplain, and the potential for flooding is minimal. A combination of open drainage ditches and storm drains is used to capture and direct runoff from the Base (Eaker AFB, 1992). Stormwater runoff in the eastern portion of the Base drains to Pemiscot Bayou, while surface water flow on the western half of the Base drains to Ditch 25. Both of these drainage channels flow southwest to the Little River, which discharges into the St. Francis River. The St. Francis River discharges into the Mississippi River approximately 150 miles south of Eaker AFB. Surface water flow at the BX Shoppette discharges into the adjacent surface drainages which flow into Ditch Number 25, located approximately 4,000 feet north of the site.

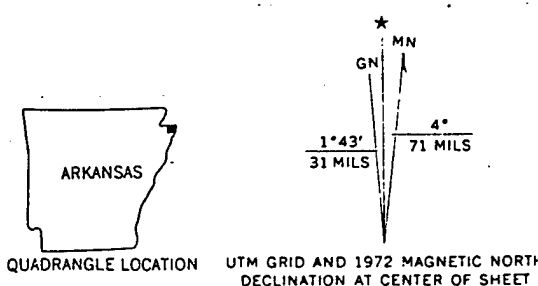
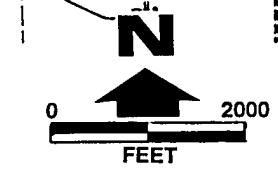
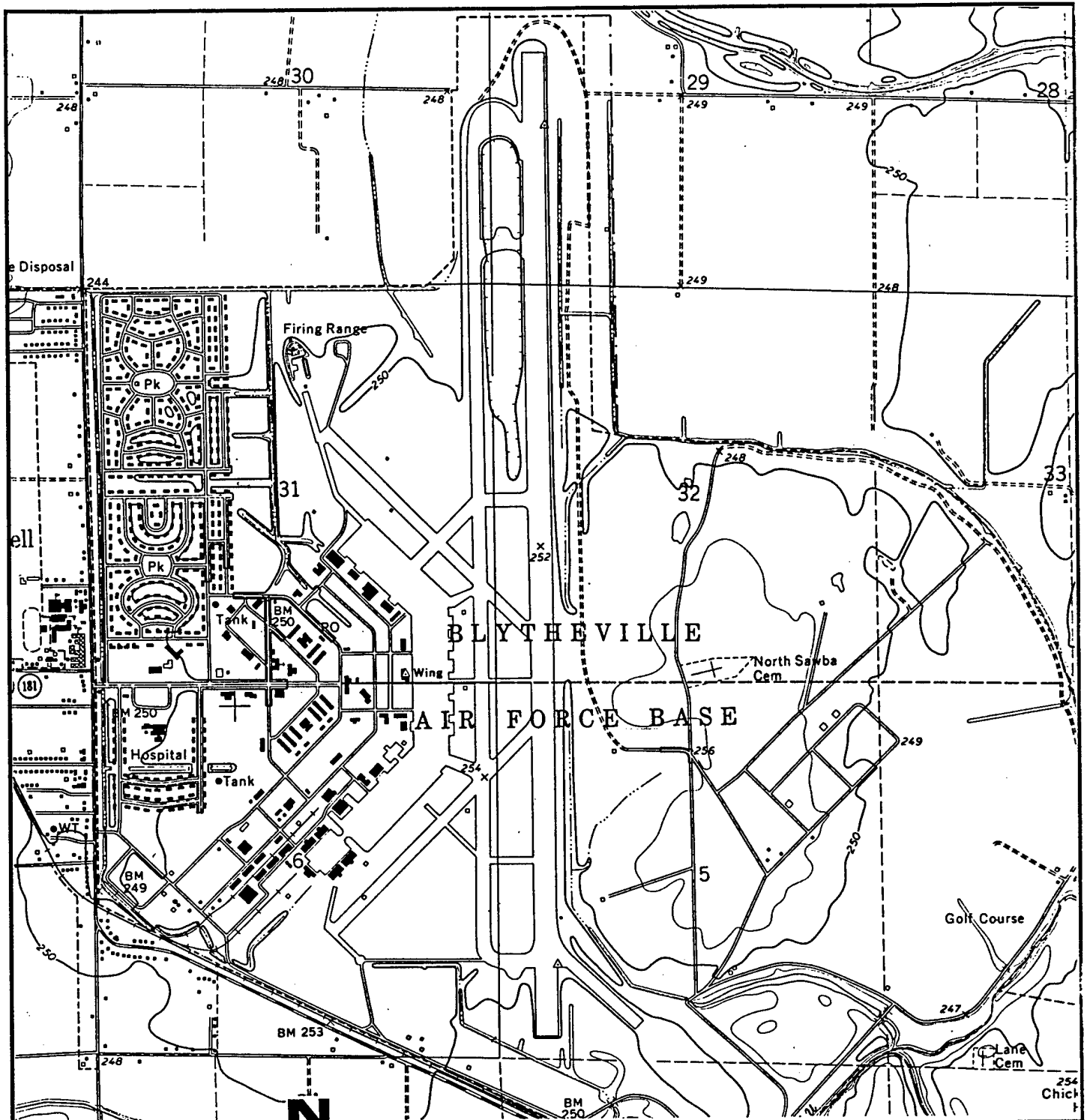

Sources: USGS, 1972.

FIGURE 2.1
REGIONAL TOPOGRAPHIC MAP
 BX Shoppette
 Intrinsic Remediation TS
 Eaker AFB, Arkansas
PARSONS ENGINEERING SCIENCE, INC.
 Denver, Colorado

The Eaker AFB climate is subtropical, with mild winters and hot, humid summers. July is the warmest month with an average maximum daily temperature of 90 degrees Fahrenheit (°F). The coolest month is January with an average minimum daily temperature of 28°F. The average annual precipitation is 48.3 inches, which is evenly distributed throughout the year. The average annual relative humidity is 69 percent. Flooding occurs during periods of prolonged heavy rainfall, and during the summer months climatic conditions make tornado formation possible (Eaker AFB, 1992).

2.1.2 Overview of Geology and Hydrogeology

2.1.2.1 Regional Geology and Hydrogeology

The shallow subsurface geology of northeastern Arkansas consists of Quaternary alluvium, which is thickest near the Mississippi River and thins in a westerly direction. The alluvium is composed of interbedded clays, silts, sand, and minor gravel and has an average thickness of 125 feet (Eaker AFB, 1992). The shallow, unconsolidated, Quaternary sediments on Eaker AFB are interpreted to be flood plain and channel deposits associated with the past and present positions of the Mississippi River (Halliburton NUS, 1992). The overlying soils are weathering products of the alluvial deposits and are generally nontransmissive, fine-grained, clayey soils. These soils impede infiltration and allow for rapid runoff of surface water.

Sediments in the vicinity of the Base consist of over 2,000 feet of Tertiary and Cretaceous unconsolidated deposits overlying Lower Paleozoic carbonate bedrock (Eaker AFB, 1992). The Tertiary Wilcox Formation is present approximately 900 feet below the Base. The lower part of this formation is composed of sands that produce potable water used by Eaker AFB, the city of Blytheville, and the city of Gosnell (Eaker AFB, 1992).

The aquifer is under confined conditions, and the water quality is excellent. Water treatment is required only to remove slightly elevated iron concentrations. The lower Wilcox Formation aquifer is protected from contamination by approximately 800 feet of interbedded unconsolidated sands and clays that form the Claiborne Group.

Shallow groundwater in the vicinity of the Base is present between 7 and 12 feet bgs and in the Quaternary alluvial sands. Irrigation wells and rural residences generally obtain water from these Quaternary sands (Eaker AFB, 1992). The upper part of the Quaternary deposits consists of sandy clay and clay, while the remainder of the deposits are sand and gravel. The sands and gravels comprise the major water-bearing units in the Quaternary deposits. Water from the alluvial aquifer is characterized as moderately hard to very hard hardness (as calcium bicarbonate). The water table is highest in the area northeast of the Base, indicating an area of surface recharge to the Quaternary sands and gravels (Eaker, 1992). Flood control for the Mississippi River and local flooding are responsible for some groundwater elevation fluctuation. Groundwater in the vicinity of Eaker AFB flows southwest to south.

2.1.2.2 BX Shoppette Geology and Hydrology

Most of the ground surface at the BX Shoppette is covered by about 6 inches of asphalt pavement overlying approximately 2 to 4 feet of sandy fill material. On the basis of information collected during the previous investigations, the shallow alluvial sediments at the site consist primarily of interbedded clays (with or without silt), sands, and sandy clays. Below the fill are several interbedded clayey, sandy, and silty layers extending to approximately 10 to 15 feet bgs. This series of units varies in texture both laterally and vertically across the site. Underlying the top 12 to 19 feet of soil is a stiff, gray and brown clay. The base of the clay layer is undefined, but this layer is suspected

to be a minimum of 10 feet thick. A medium- to coarse-grained sand unit underlies the clay where the sand is present. The sand has not been observed in all deep boreholes and is not believed to be laterally continuous across the site. Figure 2.2 shows the location of stratigraphic cross-sections A-A' and B-B'. Figure 2.3 presents cross-section A-A', which is oriented in a northwest-southeast direction along the axis of groundwater flow. Figure 2.4 presents cross-section B-B', oriented southwest-northeast, approximately perpendicular to the direction of groundwater flow.

The cross-sections were constructed using geologic boring logs from the Halliburton NUS (1992) site investigation and CPT/laser induced fluorescence (LIF) verification data results collected by the US Army Corps of Engineers (USACE, 1995). The CPT soil data were interpreted using a soil classification graph and a fluorescence graph. The soil graph is constructed by referencing the strain gauge readings, calibration curves, and an empirical relationship. The fluorescence graph presents the relative measurement of the returned fluorescence from the LIF window on the probe. This is a relative measurement of the fuel hydrocarbon contamination. By comparing the CPT soil graph with existing adjacent soil borehole logs, the data were correlated to produce a more complete cross-section and to better define locations of suspected mobile LNAPL. Appendix B presents available geologic boring logs and CPT/LIF output logs

Borehole logs from downgradient monitoring well MW1126 at the eastern corner of the BX Shoppette near Arkansas Avenue (Figure 2.2) show that soils from the surface to 3 feet bgs are a silt and fine-grained sand. From 3 feet bgs to approximately 14 feet bgs is an orange-brown, silty clay, with the silt content decreasing with depth. Below 14 feet bgs, a dark-gray to brown clay with organic fragments and worm burrows extends to 25 feet bgs. The silt content of the clay soil increases with depth, and a fine-grained sandy

- LEGEND**
- MW1104
 - TEMPORARY WELL
 - GROUNDWATER FLOW DIRECTION
 - SURFACE DRAINAGE
 - GEOLOGIC CROSS-SECTION LOCATION

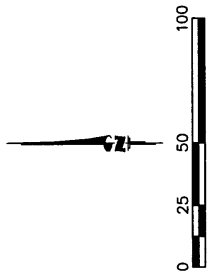
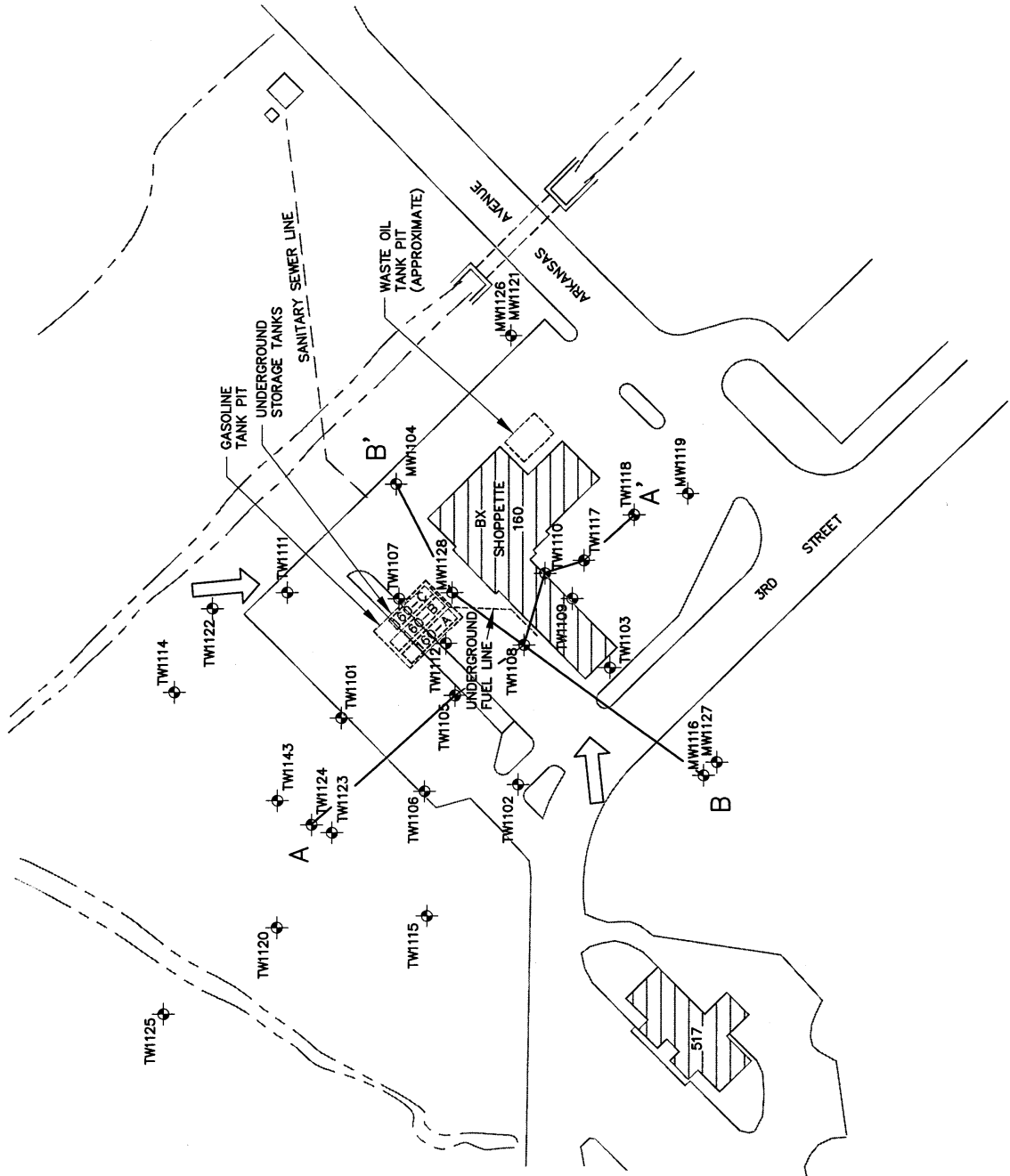

FIGURE 2.2

**HYDROGEOLOGIC
CROSS-SECTION LOCATIONS**

BX Shoppette
Intrinsic Remediation TS
Eaker AFB, Arkansas

**PARSONS
ENGINEERING SCIENCE, INC.**
Denver, Colorado



A

TW118

TW110



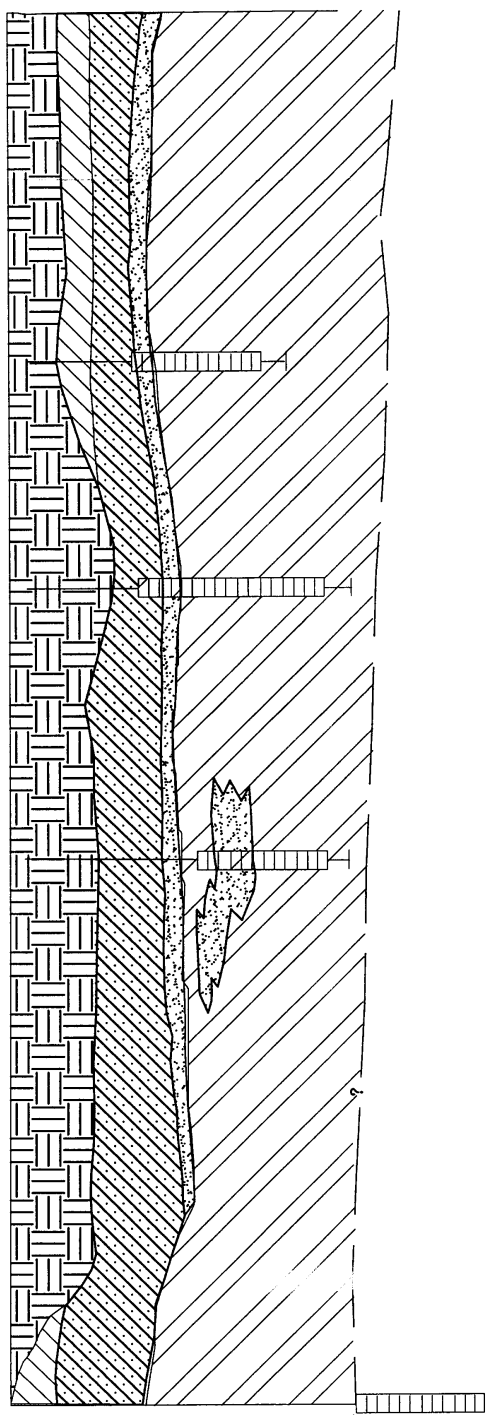

TW108

TW105

TW124



LEGEND

-  Fill, sand, some gravel and silt
-  Silty clay, some fine sand
-  Sandy clay, brown, gray mottles, some silt
-  Sand, fine-to-medium-grained, gray saturated
-  Clay, gray, plastic, some minor silt saturated

Sand, fine-to-medium-grained angular quartz, brownish gray, poorly sorted

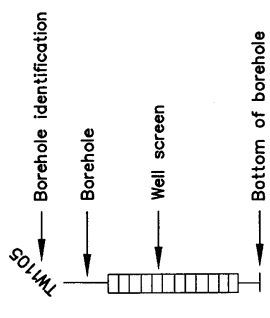

Geologic Contact (Dashed where inferred)

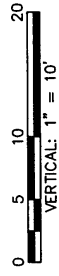
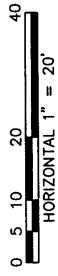

FIGURE 2.3

CROSS-SECTION A-A'

BX Shoppette
 Intrinsic Remediation TS
 Eaker AFB, Arkansas

PARSONS ENGINEERING SCIENCE, INC.
 Denver, Colorado

B

B



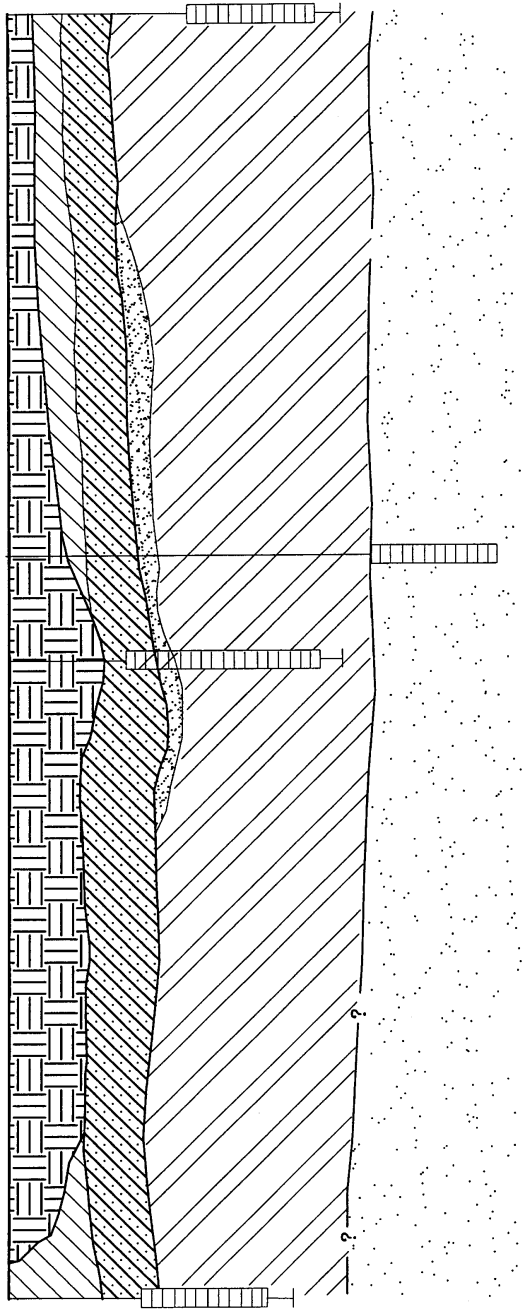

MWT104

MWT128

TW108



LEGEND

-  Fill, sand, some gravel and silt
-  Silty clay, some fine sand
-  Sandy clay, brown, gray mottles, some silt
-  Sand, fine-to-medium-grained, gray saturated
-  Clay, gray, plastic, some minor silt saturated

 Sand, fine-to-medium-grained angular quartz, brownish gray, poorly sorted

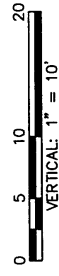
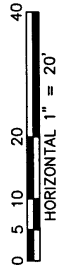
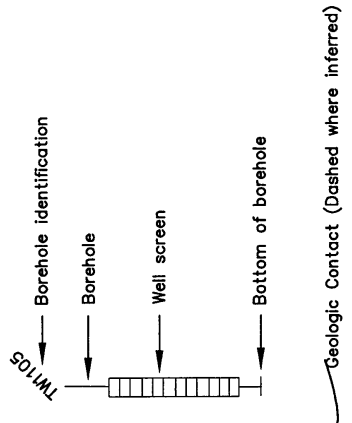

FIGURE 2.4

CROSS-SECTION B-B'

BX Shopette
 Intrinsic Remediation TS
 Eaker AFB, Arkansas

PARSONS ENGINEERING SCIENCE, INC.
 Denver, Colorado

clay is present to a depth of approximately 29 feet bgs. From 29 feet bgs to a total drilled depth of 41 feet bgs a medium-grained, poorly sorted quartz sand is present.

There are currently 21 groundwater monitoring wells at the BX Shoppette. Seven former temporary monitoring wells have been abandoned at the site. All of the wells are screened in the shallow alluvial deposits. These wells were installed during several site investigations as part of the IRP. Groundwater at the site occurs in the sandy units of the Quaternary alluvium and may be perched above the finer-grained clay sediments. Available monitoring well construction details are presented in Table 2.1. Figure 2.5 shows the groundwater surface for the BX Shoppette in March 1992.

Groundwater flow in the immediate vicinity of the site appears to converge on the site from two different directions. West of the BX Shoppette the groundwater flow is to the northeast; however, the confluence of two drainage channels north of the station appears to create a recharge zone, resulting in a southerly groundwater flow from the confluence toward the site. As a result, groundwater flow directly beneath the BX Shoppette is deflected to the east by the convergent flows. The hydraulic gradient across the site ranges from 0.016 foot per foot (ft/ft) south of the fuel tank pit to 0.0017 ft/ft in the immediate tank pit and dispenser area (Halliburton NUS, 1992). The groundwater surface shown on Figure 2.5 correlates with the shape and orientation of the groundwater BTEX plume, implying that the groundwater flow direction at the site is relatively consistent. The converging groundwater flow combined with the small gradient beneath the site, gives groundwater a relatively longer residence time below the site.

In 1988, Halliburton NUS (1992) performed slug tests on shallow aquifer monitoring wells located approximately 2,500 feet northeast of the BX Shoppette. Using the methods of Bouwer and Rice (1976), hydraulic conductivity values at monitoring wells

TABLE 2.1
SUMMARY OF WELL COMPLETION DATA
BX SHOPPETTE
INTRINSIC REMEDIATION TS
EAKER AFB, ARKANSAS

Well ID	Installation Date	Total Depth (ft bgs)	Completion Depth (ft bgs)	Screened Interval (ft bgs)	Ground Elevation (ft msl)	Top of Casing (ft msl)
TW1101	12/11/91	30	27.2	15.2-25.2	NA ^{a/}	NA
TW1102	12/11/91	30	24.7	12.4-22.6	NA	249.52
TW1103 ^{b/}	12/11/91	30	27.1	15.1-25.1	NA	249.99
MW1104	12/11/91	30	26.1	14.1-24.1	NA	251.48
TW1105	12/13/91	26	25.2	13.4-23.4	NA	251.14
TW1106	12/13/91	29	25.7	13.5-23.7	NA	250.98
TW1107	12/13/91	30	27.2	15.1-25.2	NA	251.31
TW1108	12/14/91	29	25.2	8.2-23.2	NA	250.75
TW1109	12/14/91	25	20.2	8.2-18.2	NA	250.89
MW1110	12/14/91	25	20.3	8.2-18.2	NA	251.23
MW1111	12/15/91	22	20.1	8.1-18.1	NA	251.32
TW1112	12/15/91	25	25.1	8.1-25.1	NA	250.86
TW1113	12/15/91	27	25.3	8.4-23.3	NA	252.01
MW1114	12/16/91	24	18.4	6.2-16.4	NA	251.64
MW1115	12/16/91	22	18.3	6.2-16.3	NA	250.37
MW1116	12/16/91	22	20	7.9-18.0	NA	250.62
TW1117	12/17/91	12	NA	NA	NA	250.83
TW1118	12/17/91	12	NA	NA	NA	250.42
MW1119	12/17/91	22	17	5.0-15.0	NA	249.75
MW1120	1/7/92	30	29.2	17.2-27.2	NA	251.73
MW1121	4/8/95	17	16.2	4.2-14.2	250.97	253.16
MW1122	4/7/95	18	17.3	5.1-15.1	250.68	253.02
MW1123	8/11/95	20	19	7.0-17.0	251.13	253.56
MW1124	8/12/95	38	38	26.0-36.0	251.93	253.58
MW1125	10/31/95	38	38	26.0-36.0	250.58	253.48
MW1126	11/1/95	41	41	29.0-39.0	250.91	253.70
MW1127	11/3/95	37	36.5	24.5-34.5	250.76	250.56
MW1128	11/5/95	40	40	28.0-38.0	NA	251.34

^{a/} NA = Data not available.

^{b/} Temporary wells TW1103, TW1107, TW1108, TW1112, TW1113, TW1117, and TW1118 have been removed.

Sources: Halliburton NUS, 1992 and 1995.

- LEGEND**
- MONITORING WELL WITH GROUNDWATER
 - TEMPORARY WELL WITH GROUNDWATER
 - GROUNDWATER FLOW DIRECTION
 - SURFACE DRAINAGE
 - GROUNDWATER ELEVATION CONTOUR LINE (feet msl) (DASHED WHERE APPROXIMATE)

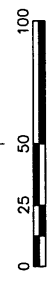
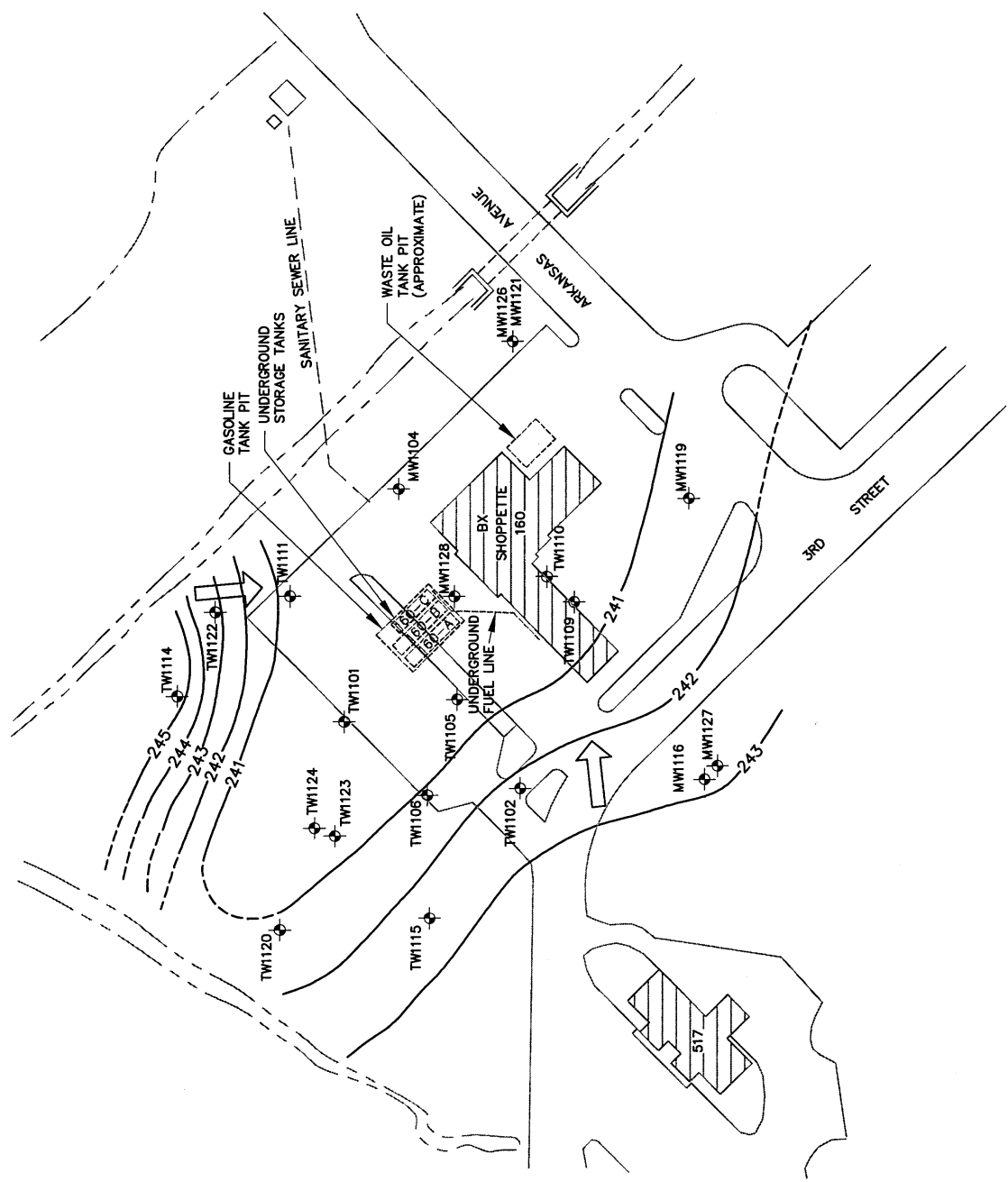

FIGURE 2.5
GROUNDWATER ELEVATION MAP
(MARCH 27, 1992)

BX Shoppette
 Intrinsic Remediation TS
 Eaker AFB, Arkansas

PARSONS ENGINEERING SCIENCE, INC.
 Denver, Colorado



MW502 and MW504 were calculated to be 2.1×10^{-4} centimeters per second (cm/sec) and 5.4×10^{-4} cm/sec, respectively. Using the average of these two measurements, Halliburton NUS (1992) estimated the hydraulic conductivity to be 1.06 feet per day (ft/day) (3.7×10^{-4} cm/sec) beneath the site. Using a gradient of 0.0017 ft/ft and an estimated porosity of 0.25, the groundwater velocity at the BX Shoppette is approximately 0.007 ft/day. Halliburton NUS (1992) assumed an aquifer thickness of 10 feet and calculated an estimated aquifer transmissivity of 79 gallons per day per foot (gal/day/ft) in the shallow alluvial aquifer below the BX Shoppette.

2.1.3 Summary of Analytical Data for BX Shoppette

2.1.3.1 Soil Sampling and Analytical Results

Historical soil sampling data are available for sampling events that took place in 1991 and 1995. In 1991, 56 soil samples were collected by Halliburton NUS (1994) from boreholes B-1 through B-27, and 12 soil samples were collected from boreholes for wells TW1103, TW1108, TW1109, and TW1110 (Figure 2.6). Four years later, Halliburton NUS (1995) collected 11 additional soil samples during the installation of monitoring wells MW1121 through MW1123 and soil boreholes SB1129 through SB1135. All the soil samples collected during these sampling events were analyzed for BTEX and total petroleum hydrocarbons (TPH). Some soil samples were analyzed for additional contaminants [i.e., metals and semivolatile organic compounds (SVOCs)]; however, results reported for these additional analytes are not of primary importance for completion of this TS and are not summarized in this work plan. Table 2.2 summarizes BTEX and TPH results for all soil samples collected during these sampling efforts. Locations of soil samples collected during the 1991 investigation are shown on Figure 2.6.

TABLE 2.2
SUMMARY OF SOIL ANALYTICAL DATA
BX SHOPPETTE
INTRINSIC REMEDIATION TS
EAKER AFB, ARKANSAS

Borehole ID	Date	Depth (ft bgs)	Benzene (mg/kg)	Toluene (mg/kg)	Ethylbenzne (mg/kg)	Total Xylenes (mg/kg)	Total BTEX (mg/kg)	TPH (mg/kg)
B-1	2/91	5-10 ^a	6.2	47	14	80	147.2	322
		15	2.4	8.2	4.5	17	32.1	176
B-2	2/91	5-10	2.3	24	7.7	40	74	248
		15	3.1	8.6	0.3	2.1	14.1	478
B-3	2/91	5-10	14	250	62	300	626	338
		15	3.6	16	1.8	9.8	31.2	176
B-4	2/91	5-10	ND ^b	22	3.7	14	39.7	484
		15	ND	ND	ND	ND	ND	477
B-5	2/91	5-10	15	130	22	90	257	559
		15	2.4	15	3.9	16	37.3	351
B-6	2/91	5-10	1.5	18	2.5	14	36	218
		15	1.6	6.2	1	4.6	13.4	147
B-7	2/91	5-10	3.8	44	7.3	44	99.1	212
		15	1.1	0.9	0.2	0.1	2.3	247
B-8	2/91	5-10	5	27	7	39	78	157
		15	ND	ND	ND	ND	ND	163
B-9	2/91	5-10	7.6	43	16	88	154.6	136
		15	1.6	1.4	0.2	0.5	3.7	179
B-10	2/91	5-10	11	72	20	110	213	152
		15	ND	ND	ND	ND	ND	203
B-11	2/91	5-10	3.2	15	2.8	14	35	234
		15	1.9	5.2	0.6	2.2	9.9	240
B-12	2/91	5-10	6.3	35	8.2	44	93.5	207
		15	1.6	5.2	0.5	2.4	9.7	210
B-13	6/91	5-10	5.3	24	6.8	33	69.1	<30
		15	0.7	1.1	ND	0.4	2.2	<30
		20	0.8	1.2	0.2	0.8	3	<30
B-15	6/91	5-10	5.1	4.2	9.4	73	91.7	46
		15	7.9	30	6.1	27	71	<30
		20	3.7	16	4.5	24	48.2	35
B-16	6/91	5-10	9	37	11	46	103	<30
		15	ND	ND	ND	ND	ND	<30
		20	ND	ND	ND	0.5	0.5	<30
B-17	6/91	5-10	2.3	13	4.3	26	45.6	<30
B-18	6/91	5-10	7.2	20	3.7	22	52.9	<30
		15	6.2	19	5.2	24	54.4	<30
B-19	6/91	5-10	0.5	3	5.4	19	27.9	<30
		15	0.6	1.8	ND	0.7	3.1	<30
		20	0.7	1.9	0.3	0.8	3.7	<30

TABLE 2.2 (Concluded)
SUMMARY OF SOIL ANALYTICAL DATA
BX SHOPPETTE
INTRINSIC REMEDIATION TS
EAKER AFB, ARKANSAS

Borehole ID	Date	Depth (ft bgs)	Benzene (mg/kg)	Toluene (mg/kg)	Ethylbenzene (mg/kg)	Total Xylenes (mg/kg)	Total BTEX (mg/kg)	TPH (mg/kg)
B-20	6/91	5-10	3.3	26	ND	26	55.3	<30
		15	37	280	68	400	785	<30
		20	14	130	31	160	335	<30
B-21	6/91	5-10	18	84	15	100	217	30
		15	13	54	18	83	168	64
		20	8.4	22	4.7	27	62.1	<30
B-22	6/91	5-10	5.3	32	7.5	44	88.8	<30
		15	15	65	10	51	141	<30
B-23	6/91	5-10	1	17	7.1	28	53.1	<30
		15	0.6	2	1.9	7.8	12.3	<30
B-24	6/91	5-10	1.3	17	11	29	58.3	<30
		15	0.2	2.3	1.6	7.1	11.2	<30
		20	0.2	0.6	0.2	0.9	1.9	<30
B-25	6/91	5-10	4.4	28	7.9	44	84.3	<30
		15	0.2	0.8	0.1	0.8	1.9	<30
B-27	6/91	5-10	2.4	23	9.2	36	70.6	<30
		15	1.1	10	1.6	15	27.7	<30
TW1103	12/11/95	3	<1	<1	<1	3	3	<20
		10	<1	<1	<1	<1	<1	<20
		22	ND	<1	<1	<1	<1	<20
TW1108	12/14/95	5	<1	<1	<1	3	3	<20
		17	<1	<1	1	4	5	<20
		21	<1	<1	<1	<1	<1	<20
TW1109	12/14/95	6	5	17	17	78	123	172
		10	<1	<1	<1	<1	<1	<20
		18	<1	<1	<1	<1	<1	<20
TW1110	12/14/95	6-7	2	58	19	93	172	23
		8.5	1	19	<1	51	71	<20
		16.5	<1	3	<1	3	6	<20
MW1121A	4/8/95	NA ^{c/}	ND	ND	ND	ND	ND	ND
MW1122A	4/7/95	NA	<1	<1	ND	ND	<1	ND
MW1123A	8/11/95	NA	ND	ND	ND	ND	ND	ND
SB1129A	4/6/95	NA	ND	ND	ND	ND	ND	ND
SB1130A	4/6/95	NA	ND	ND	ND	ND	ND	ND
SB1131A	4/7/95	NA	<1	<1	ND	ND	<1	ND
SB1132A	4/9/95	NA	ND	ND	ND	ND	ND	ND
SB1133A	4/7/95	NA	ND	ND	ND	ND	ND	ND
SB1134A	4/8/95	NA	ND	ND	ND	ND	ND	ND
SB1135A	4/7/95	NA	0.9	2.7	1.1	5.4	10.1	38
SB1135B	4/7/95	NA	6.1	27	15	74	122.1	570

^{a/} 5-10 foot samples were composited at 5 and 10 feet.

^{b/} ND = not detected.

^{c/} NA = data not available.

Sources: Halliburton NUS, 1992 and 1995.

LEGEND

MONITORING WELL AM1104 ●
 TEMPORARY WELL TM1101 ⊕
 SOIL BORING B-1 ■

TOTAL BTEX¹
 ISOCON CONTOUR LINE (DASHED WHERE APPROX.)

FENCE

SURFACE DRAINAGE

GROUNDWATER FLOW DIRECTION

BORING OR WELL	BENZENE 1	TOTAL BTEX ¹
B-1	6.2	147.2
B-2	2.3	7.4
B-3	1.4	62.6
B-4	NOT DETECTED	39.7
B-5	1.5	251
B-6	1.5	36
B-7	3.8	99.1
B-8	5	78
B-9	7.6	154.6
B-10	1.1	213
B-11	3.2	35
B-12	6.3	93.5
B-13	5.3	69.1
B-14	NOT SAMPLED	NOT SAMPLED
B-15	5.1	91.7
B-16	9	103
B-17	2.3	55.6
B-18	7.2	52.9
B-19	0.5	27.3
B-20	3.3	55.3
B-21	18	211
B-22	5.3	68.8
B-23	1.0	53.1
B-24	1.3	56.3
B-25	4.4	64.3
B-26	NOT SAMPLED	NOT SAMPLED
B-27	2.4	70.6
B-28	NOT SAMPLED	NOT SAMPLED
TM1103	CI	3
TM1108	CI	3
TM1109	5	117
AM1110	2	172

¹ - CONCENTRATIONS IN mg/kg OF SOIL

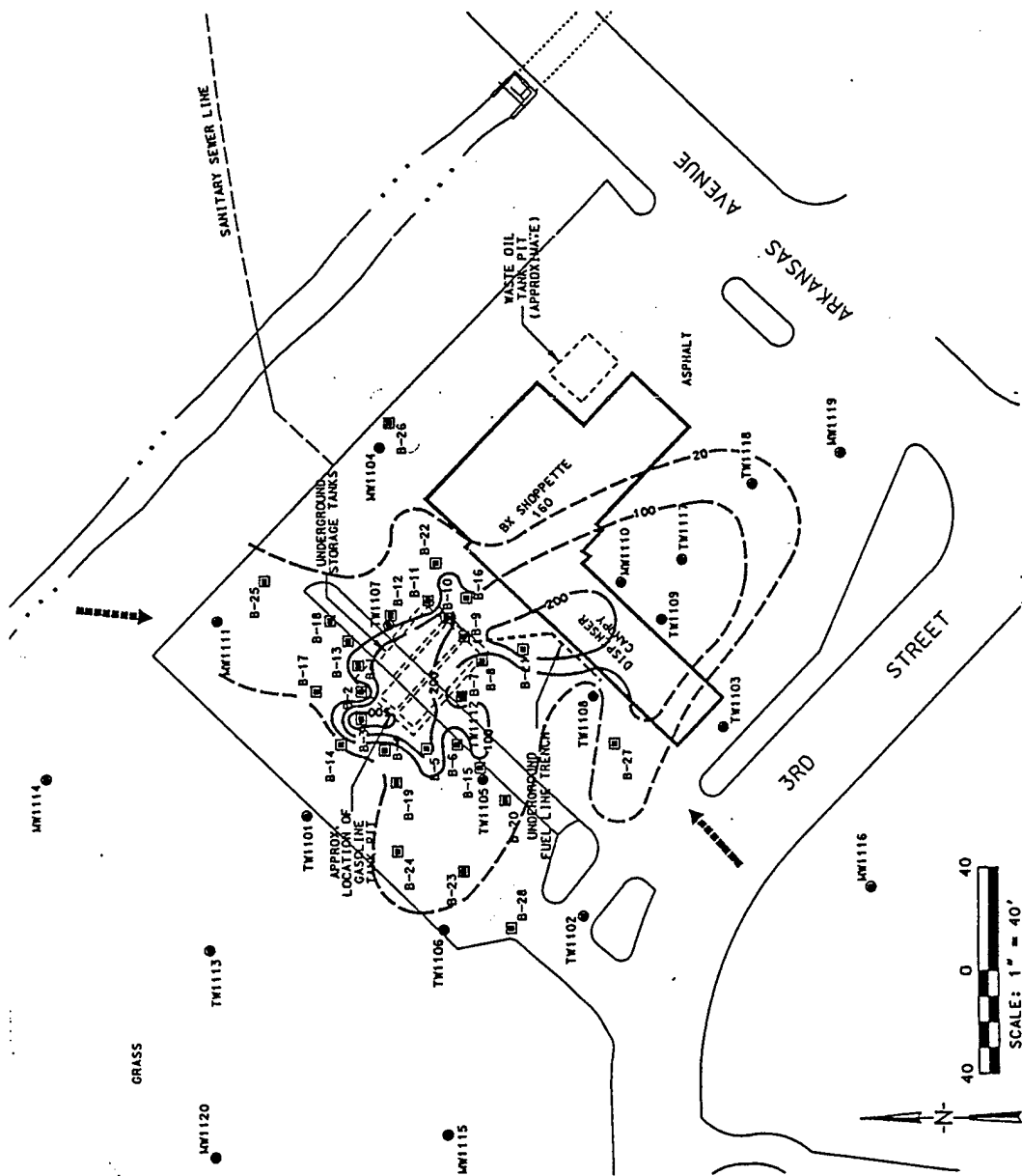

FIGURE 2.6

**SOIL BTEX CONTOUR
 (0-10 FEET BGS)
 MARCH 1991**

BX Shoppette
 Intrinsic Remediation TS
 Eaker AFB, Arkansas

**PARSONS
 ENGINEERING SCIENCE, INC.**
 Denver, Colorado

During the 1991 investigation (Halliburton NUS, 1992), saturated and unsaturated zone soil samples were collected at depths ranging from 5 to 22 feet bgs. Soil BTEX contamination was identified in saturated samples collected below the water table at 20 feet below bgs. However, the saturated samples collected below about 10 feet bgs do not correlate with surface contamination sources and are believed to result from groundwater smear of mobile LNAPL. Appendix B presents figures from Halliburton NUS (1992) that contour the soil contamination below 10 feet bgs.

Significant concentrations of BTEX and TPH in unsaturated soils appear to be limited to soils in the vicinity of the gasoline tank pit and the underground fuel line trench. Figure 2.6 is an isocontour map showing BTEX contamination in soils to a maximum depth of 10 feet bgs. The unsaturated soil BTEX contamination appears to be confined within the site boundaries. The maximum total BTEX contamination measured in unsaturated soils [626 milligrams per kilogram (mg/kg)] was detected in soil borehole B-3, adjacent to the gasoline tank pit. Unsaturated soil contamination in the region of the UST pit is concentrated mostly to the north and west of, and below, the pit. The highest unsaturated total BTEX concentration not related to the tank pit contamination was located at borehole B-21 adjacent to the fuel line trench, that lies between the tank pit and the fuel dispensers. The remainder of the soil sampling indicated lower BTEX concentrations throughout the rest of the BX Shoppette site (Figure 2.6). The fluctuation of the groundwater surface, LNAPL dispersion, and isolated small fuel spills most likely are responsible for the lower outlying soil BTEX concentrations away from the two primary source areas (i.e., the gasoline UST pit and the fuel line).

2.1.3.2 Groundwater Sampling and Analytical Results

A total of 28 monitoring wells have been installed at the BX Shoppette. All of the wells have been installed by Halliburton NUS (1992 and 1995) during several phases of investigation. Seven temporary wells (TW1103, TW1107, TW1108, TW1112, TW1113, TW1117, and TW1118) were removed by Halliburton NUS (1992) after sampling and analysis. Available well construction details are presented in Table 2.1. All of the monitoring wells at the site are screened within the shallow unconsolidated sediments. Groundwater quality data were collected from the BX Shoppette wells in 1992 and 1995 (Halliburton NUS, 1992 and 1995) as part of site assessment activities. BTEX and TPH results for both groundwater sampling events are presented in Table 2.3.

Measurable mobile LNAPL (free product) has been observed in monitoring well TW1105. Immediately after installation, well TW1105 contained 0.3 foot of LNAPL. In January 1992, 5.35 feet of product was measured at monitoring well TW1105, and in February 1992, 10.75 gallons of product was bailed from the well by Eaker AFB personnel (Halliburton NUS, 1992). In May 1992, the LNAPL was measured at approximately 4 feet. Analysis of the LNAPL indicated the product is leaded gasoline. The storage and sale of leaded gasoline at the BX Shoppette ceased in March 1990; therefore, the release that resulted in the accumulation of LNAPL in this area likely occurred before 1990. It is possible that the 1974 leak in the fuel transfer line was the source of the mobile LNAPL in this area (Halliburton NUS, 1992). The lateral extent of the mobile LNAPL plume has not been determined, but the plume is believed to be limited because it has only been observed in monitoring well TW1105. However, the observed BTEX concentration of 36,800 micrograms per liter ($\mu\text{g/L}$) in a 1995 groundwater sample from monitoring well TW1111, about 100 feet north of TW1105, is

TABLE 2.3
SUMMARY OF GROUNDWATER ANALYTICAL DATA
BX SHOPPETTE
INTRINSIC REMEDIATION TS
EAKER AFB, ARKANSAS

Well ID	Sample Date	Benzene (µg/L)	Ethylbenzene (µg/L)	Toluene (µg/L)	Total Xylene (µg/L)	Total BTEX (µg/L)	TPH (mg/L)
TW1101	6/1/95	610	310	440	880	2240	9
TW1102	6/1/95	ND ^{a/}	ND	ND	ND	ND	ND
MW1104	1/13/92	< 2	< 2	< 2	< 2	< 8	< 0.2
	6/2/95	130	210	170	560	1070	16
TW1105	NS ^{b/}	NS	NS	NS	NS	NS	NS
TW1106	6/2/95	ND	ND	ND	ND	ND	ND
TW1109	6/5/95	2200	170	160	1100	3630	15.5
MW1110	1/13/92	4800	2000	45000 J ^{c/}	7600	59700 J	2
	6/2/95	10000	1000	280	3200	14480	52.5
MW1111	1/13/92	5300 J	1500 J	< 2	7120 J	13920 J	2.7
	6/2/95	5000	2800	14000	15000	36800	21.2
	8/15/95	4100	2000	11000	14000	31100	67
MW1114	1/13/92	< 2	< 2	< 2	< 2	< 8	< 0.2
	6/5/95	ND	ND	ND	ND	ND	ND
MW1115	1/13/92	< 2	< 2	< 2	< 2	< 8	< 0.2
	6/5/95	ND	ND	ND	ND	ND	ND
MW1116	1/12/92	< 2	< 2	< 2	< 2	< 8	< 0.2
	6/5/95	ND	ND	ND	ND	ND	ND
MW1119	1/13/92	< 2	< 2	< 2	< 2	< 8	< 0.2
	6/5/95	ND	ND	ND	ND	ND	ND
MW1120	1/12/92	< 2	< 2	< 2	< 2	< 8	< 0.2
	6/8/95	ND	ND	ND	ND	ND	ND
MW1121	6/8/95	ND	ND	ND	ND	ND	ND
MW1122	6/8/95	ND	ND	ND	ND	ND	ND
MW1123	8/24/95	ND	ND	ND	ND	ND	ND
MW1124	8/25/95	62	5.4	4.5	10	81.9	ND

Sources: Halliburton NUS, 1992 and 1995.

^{a/} ND = Not detected.

^{b/} NS = Not sampled because mobile LNAPL was present.

^{c/} J = Estimated value.

near equilibrium BTEX concentrations, and therefore this well may also contain free product.

Elevated concentrations of dissolved BTEX in groundwater correspond with regions of mobile LNAPL and soil contamination (Figure 2.7). Total BTEX concentrations in excess of 10,000 µg/L were detected in 1995 groundwater samples collected from TW1110 and TW1111 (Halliburton NUS, 1995). The dissolved BTEX plume shape is relatively symmetrical; and it does not appear to be traveling away from the site. The convergent groundwater flow from the west and north, coupled with the flat hydraulic gradient appears to be acting to limit plume migration away from the BX Shoppette. The shape of the BTEX plume indicates relatively minor plume expansion to the northwest and southeast. This observed plume expansion may be the result of the BTEX plume traveling within the shallow aquifer in deeper, more conductive layers. At monitoring well cluster MW1123 and MW1124, BTEX compounds were not detected in groundwater samples from the shallower well (MW1123), but 81.9 µg/L total BTEX was detected in a groundwater sample from the deeper well, (MW1124). BTEX was not detected at the shallow downgradient well MW1121; and data from the deeper adjacent well, MW1126, were not available. The downgradient extent of dissolved BTEX in deeper aquifer zones has not been completely defined.

2.1.3.3 Geochemical Indicators of BTEX Degradation

Biodegradation of dissolved fuel hydrocarbons causes measurable changes in groundwater chemistry (Wiedemeier *et al.*, 1995). Microorganisms obtain energy for cell production and maintenance by facilitating thermodynamically advantageous reduction/oxidation reactions involving the transfer of electrons from electron donors to available electron acceptors. This results in the oxidation of the electron donor and the

LEGEND

- MONITORING WELL WITH GROUNDWATER BTEX CONCENTRATION ($\mu\text{g/L}$)
- TEMPORARY WELL WITH GROUNDWATER BTEX CONCENTRATION ($\mu\text{g/L}$)
- GROUNDWATER FLOW DIRECTION
- SURFACE DRAINAGE
- NOT DETECTED
- LINE OF EQUAL GROUNDWATER BTEX CONCENTRATION ($\mu\text{g/L}$) (DASHED WHERE APPROXIMATE)

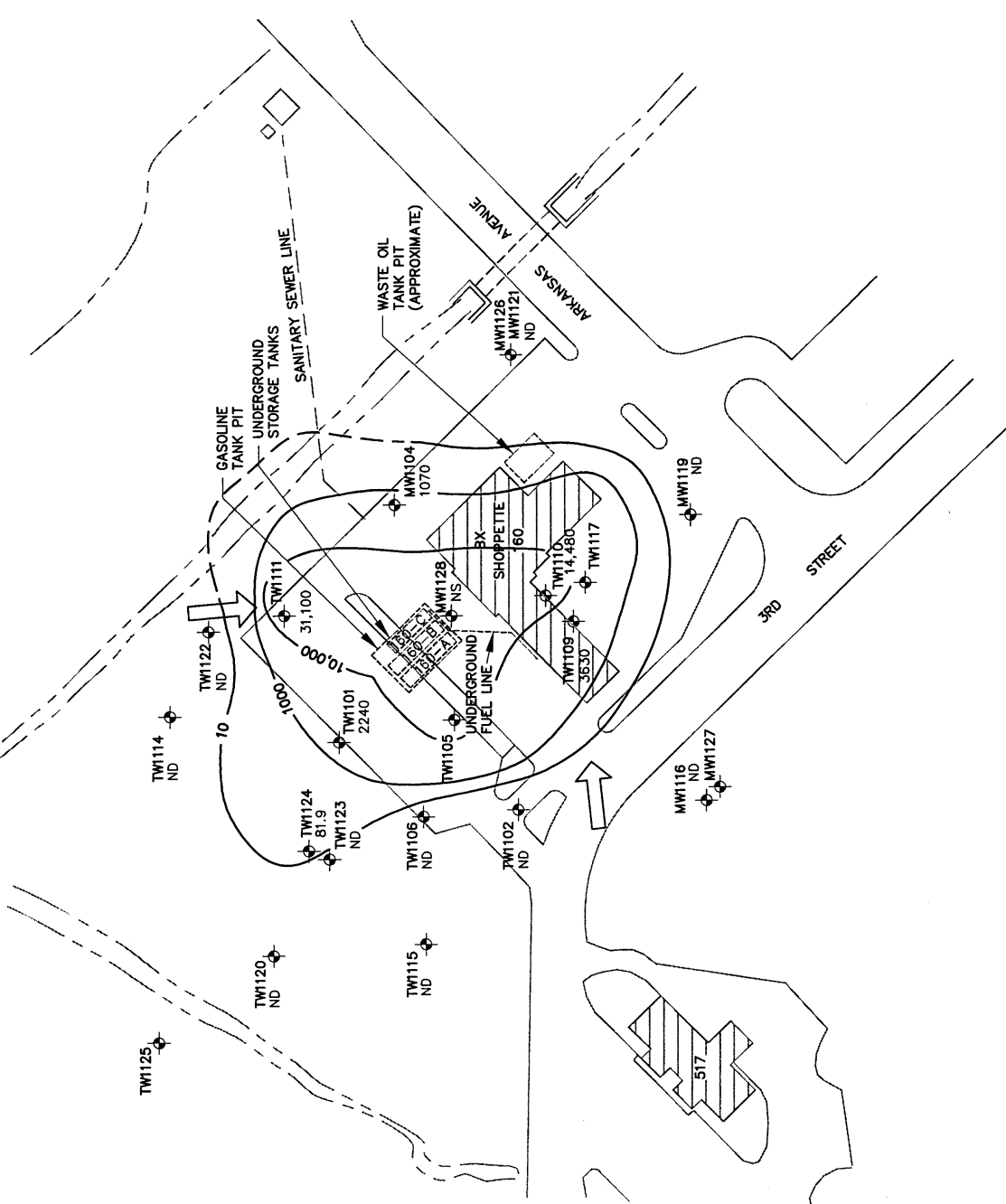

FIGURE 2.7
GROUNDWATER BTEX ISOPLETH MAP
AUGUST 1995
 BX Shoppette
 Intrinsic Remediation TS
 Eaker AFB, Arkansas
PARSONS ENGINEERING SCIENCE, INC.
 Denver, Colorado

reduction of the electron acceptor. Electron donors at the BX Shoppette include natural organic carbon and fuel hydrocarbon compounds. Electron acceptors are elements or compounds that occur in relatively oxidized states, and include dissolved oxygen, nitrate, ferric iron, sulfate, and carbon dioxide.

During aerobic respiration of BTEX compounds, oxygen is used as an electron acceptor during microbial mineralization of carbon, and dissolved oxygen concentration decrease. In anaerobic systems where sulfate, nitrate, and ferric iron are available electron acceptors, the concentrations of sulfate and nitrate decrease, and the ferrous iron concentrations increase. In anaerobic conditions where carbon dioxide is used as an electron acceptor, it is reduced by methanogenic bacteria, and methane is produced. Groundwater geochemical data collected at 16 wells at the BX Shoppette by Halliburton NUS (1995) are summarized in Table 2.4. The data indicate that anaerobic biodegradation of BTEX through sulfate reduction may be occurring at the site. Aerobic biodegradation may be occurring, but data indicating this are not available.

Groundwater alkalinity is a measure of the ability of groundwater to buffer changes in pH caused by the generation of biologically generated acids. Increased alkalinity in the areas of groundwater BTEX contamination can occur in response to increased carbon dioxide concentrations, which are a product of BTEX biodegradation (Morell and Hering, 1993). Figure 2.8 presents an isopleth map of groundwater alkalinity in August 1995.

Sulfate also appears depleted in the areas corresponding to the BTEX plume (Figure 2.7) at the site, which suggests anaerobic BTEX biodegradation through sulfate reduction. Figure 2.9 is an isopleth map of August 1995 groundwater sulfate concentrations. In this anaerobic process, the BTEX compounds combine with sulfate and hydrogen to produce carbon dioxide, water, and sulfur. Comparison of Figures 2.8 and 2.9 with the





TABLE 2.4
SUMMARY OF GROUNDWATER GEOCHEMICAL DATA
BX SHOPPETTE
INTRINSIC REMEDIATION TS
EAKER AFB, ARKANSAS

Well ID	Nitrate (mg/L)	Alkalinity (mg/L)	Sulfate (mg/L)	Chloride (mg/L)
TW1101	ND ^{a/}	280	13	5
TW1102	ND	270	382	5
MW1104	ND	260	38	7
TW1106	0.013	430	7	4
TW1109	0.1	330	22	36
MW1110	0.12	350	3	200
MW1111	0.03	220	ND	ND
MW1114	ND	83	102	24
MW1115	0.16	81	57	9
MW1116	0.02	120	52	3
MW1119	0.01	630	86	9
MW1120	ND	240	2.5	ND
MW1121	0.13	62	15	ND
MW1122	ND	110	46	ND
MW1123	ND	140	14	ND
MW1124	ND	170	28	1

^{a/} ND = Not detected.

Source: Halliburton NUS, 1995.

LEGEND

- 
 MONITORING WELL WITH GROUNDWATER ALKALINITY (mg/L)
- 
 TEMPORARY WELL WITH GROUNDWATER ALKALINITY (mg/L)
- 
 GROUNDWATER FLOW DIRECTION
- 
 SURFACE DRAINAGE
- 
 LINE OF EQUAL GROUNDWATER ALKALINITY (mg/L) (DASHED WHERE APPROXIMATE)

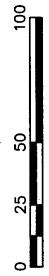
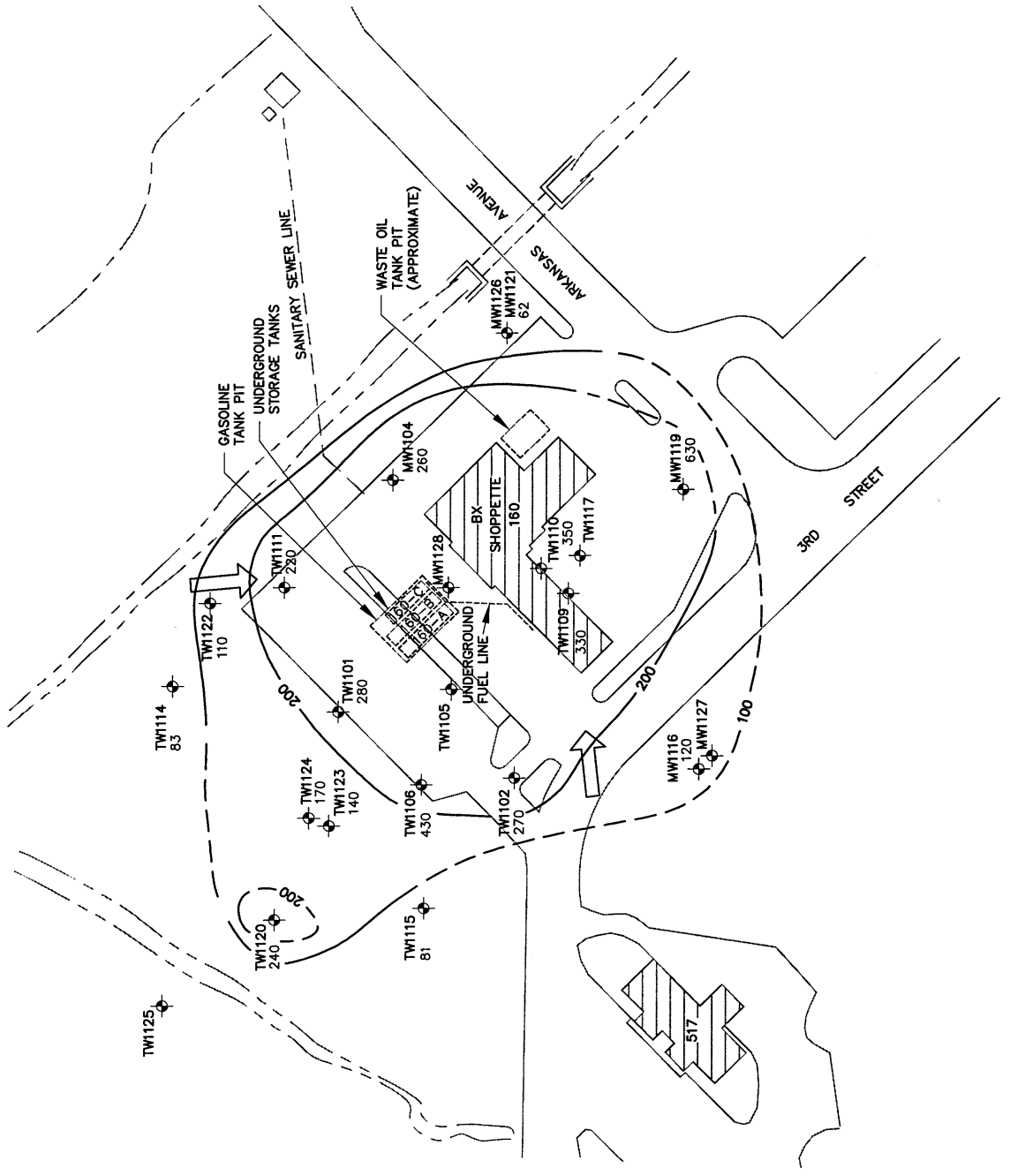

FIGURE 2.8







GROUNDWATER ALKALINITY ISOPLETH MAP AUGUST 1995

BX Shopette
 Intrinsic Remediation TS
 Eaker AFB, Arkansas

PARSONS ENGINEERING SCIENCE, INC.
 Denver, Colorado



LEGEND

- 
 MONITORING WELL WITH GROUNDWATER SULFATE CONCENTRATION (mg/L)
- 
 TEMPORARY WELL WITH GROUNDWATER SULFATE CONCENTRATION (mg/L)
- 
 GROUNDWATER FLOW DIRECTION
- 
 SURFACE DRAINAGE
- 
 NOT DETECTED
- 
 LINE OF EQUAL GROUNDWATER SULFATE CONCENTRATION (mg/L) (DASHED WHERE APPROXIMATE)

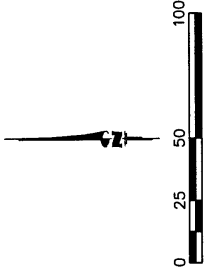
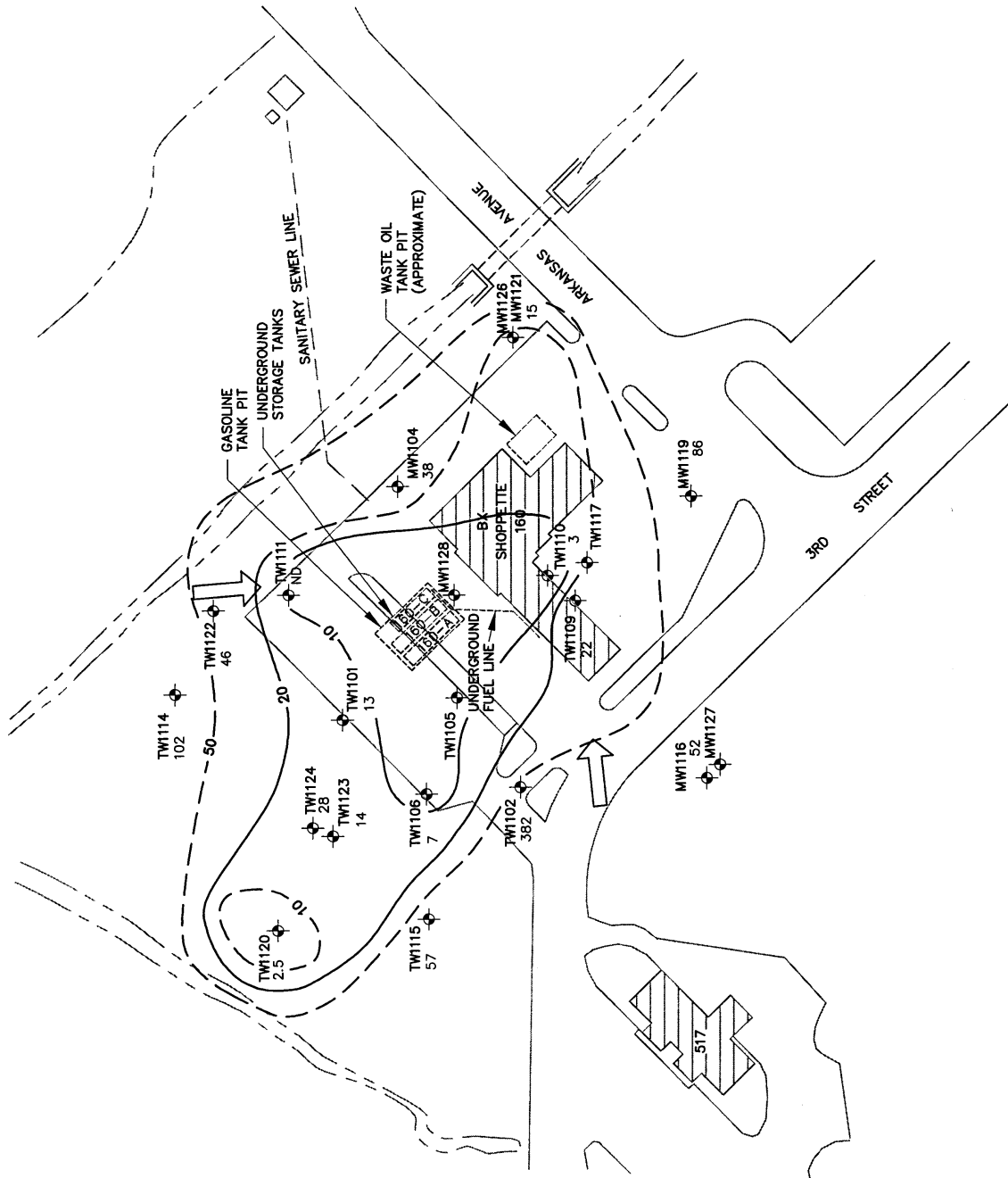

FIGURE 2.9
GROUNDWATER SULFATE ISOPLETH MAP
AUGUST 1995
 BX Shoppette
 Intrinsic Remediation TS
 Eaker AFB, Arkansas
PARSONS ENGINEERING SCIENCE, INC.
 Denver, Colorado

groundwater BTEX plume (Figure 2.7) shows graphically that the areas of relatively high alkalinity and reduced sulfate correspond with the BTEX plume. This is a preliminary indication that biodegradation of BTEX compounds is occurring at the site. Additional analysis of these and other attenuation processes will be provided in the TS report.

2.2 DEVELOPMENT OF CONCEPTUAL SITE MODEL

A CSM is a three-dimensional representation of a site's hydrogeologic system based on available geological, hydrological, climatological, and geochemical data. A CSM is developed to provide an understanding of the mechanisms controlling contaminant fate and transport and to identify additional data requirements. The model describes known and suspected sources of contamination, types of contamination, affected media, and contaminant migration pathways. The model also provides a foundation for formulating decisions regarding additional data collection activities and potential remedial actions. The CSM for the BX Shoppette will be used to aid in selecting additional data collection points and to identify appropriate data needs for quantifying and simulating groundwater flow characteristics and evidence of hydrocarbon degradation using groundwater flow and solute transport models.

Successful conceptual model development involves:

- Defining the problem to be solved;
- Integrating available data, including
 - Local geologic and topographic data,
 - Hydraulic data,
 - Site stratigraphic data, and

- Contaminant concentration and distribution data;
- Evaluating contaminant fate and transport characteristics;
- Identifying contaminant migration pathways;
- Identifying potential receptors and receptor exposure points; and
- Determining additional data requirements.

2.2.1 Predicting Intrinsic Remediation with Fate and Transport Models

The positive effect of natural attenuation processes (e.g., advection, dispersion, sorption, and biodegradation) on reducing the actual mass of fuel-related contamination dissolved in groundwater has been termed intrinsic remediation. Advantages of intrinsic remediation include: (1) contaminants are transformed to innocuous byproducts (e.g., carbon dioxide and water), not just transferred to another phase or location within the environment; (2) current pump-and-treat technologies are energy-intensive and generally not as effective in reducing residual contamination; (3) the process is nonintrusive and allows continuing use of infrastructure during remediation; (4) current engineered remedial technologies may pose a greater risk to potential receptors than intrinsic remediation because contaminants may be transferred into the atmosphere during remediation activities; and (5) intrinsic remediation is far less costly than conventional, engineered remedial technologies.

An accurate estimate of the potential for natural biodegradation of BTEX compounds in groundwater is important to consider when determining whether fuel hydrocarbon contamination presents a substantial threat to human health and the environment (through modeling), and when deciding what type of remedial alternative will be most cost effective in eliminating or abating such threats. Over the past two decades, numerous

laboratory and field studies have demonstrated that subsurface microorganisms can degrade a variety of hydrocarbons (Lee, 1988). This process occurs naturally when sufficient oxygen (or other electron acceptors) and nutrients are available in the groundwater. Hence, biodegradation is considered the most important natural attenuation process operating to remove BTEX contamination. The rate of natural biodegradation is generally limited by the lack of oxygen (or other electron acceptors) rather than by the lack of nutrients such as nitrogen or phosphorus. The supply of oxygen to unsaturated soil is constantly renewed by the vertical diffusion from the atmosphere. The supply of oxygen to a shallow, fuel-contaminated aquifer is constantly renewed by the influx of oxygenated, upgradient flow and precipitation recharge, and by the vertical diffusion of oxygen from the unsaturated soil zone into the groundwater (Borden and Bedient, 1986). The rate of natural biodegradation in unsaturated soil and shallow aquifers is largely dependent upon the rates at which oxygen and other electron acceptors enter the contaminated media.

By combining site-specific geochemical and chemical evidence, the potential for intrinsic remediation can be quantified through fate and transport modeling. Several analytical and numerical models are available for modeling the fate and transport of fuel hydrocarbons under the influence of advection, dispersion, sorption, and natural aerobic and anaerobic biodegradation. Analytical models may be used in conjunction with numerical models, such as Bioplume II, as appropriate. The Bioplume II numerical model is based upon the US Geological Survey (USGS) two-dimensional (2-D) solute transport model (Konikow and Bredehoeft, 1978), which has been modified to include a biodegradation component that is activated by a superimposed plume of dissolved oxygen. Bioplume II solves the USGS 2-D solute equation twice, once for hydrocarbon concentrations in the groundwater and once for a dissolved oxygen plume. The two

plumes are then combined using superimposition at every particle move to simulate biological reactions between fuel products and oxygen. As appropriate, biodegradation of contaminants by anaerobic processes is simulated using a first-order decay rate. The Bioplume II model will be used to predict the fate and transport of contaminants at the BX Shoppette site.

2.2.2 Initial Conceptual Site Model

The BX Shoppette hydrogeologic data were previously integrated to produce two hydrogeologic cross-sections of the site. Cross sections A - A' and B - B' (Figures 2.3 and 2.4) show the interbedded hydrostratigraphic units present at the site as determined from previous cross-sections and USACE (1995) CPT results. Figure 2.5 is a groundwater surface map prepared using March 1992 groundwater elevation data (Halliburton NUS, 1992)

The water table is present at approximately 7 to 12 feet bgs, in the silty sand and sandy clay deposits in the beneath the site. Groundwater flow converges in the site vicinity from the west and north, with gradients ranging from 0.016 ft/ft to 0.0017 ft/ft. On the basis of the available data, Parsons ES will model the site as an unconfined, fine-grained sand aquifer interbedded with clay sediments. The aquifer may become confined with depth due to overlying clay units, and the CSM will be modified as necessary as additional site hydrogeologic data become available. Vertical migration of site contaminants in groundwater will be further investigated in the source area near monitoring well TW1105 to evaluate the spread of dissolved BTEX in different aquifer subunits.

Mobile LNAPL is believed to be present at the BX Shoppette, and it may be necessary to use the fuel/water partitioning models of Bruce *et al.* (1991) or Cline *et al.* (1991) to provide a conservative source term to model the partitioning of BTEX from the mobile LNAPL into the groundwater. In order to use one of these models, samples of free product will be collected and analyzed for mass fraction of BTEX. Parsons ES also will collect additional groundwater samples from immediately below the LNAPL layer. Mobile LNAPL has been observed in well TW1105; the lateral extent of free product has not been determined. Figure 2.7 shows the extent of BTEX groundwater contamination at the site. Information from this map and historical soil contamination data for the site (Figure 2.6) will be used to select the locations of new monitoring wells to fully define the extents of the mobile LNAPL and dissolved BTEX plumes at the BX Shoppette.

Because of its solubility and relative toxicity, benzene is the primary chemical of interest in groundwater at the BX Shoppette. However, the synergistic effects of all of the BTEX compounds on attenuation rates make site data on all of the BTEX compounds important. Therefore, the BTEX compounds will be the primary focus of this intrinsic remediation TS. The Bioplume II model will be used to simulate the degradation of these chemicals at the BX Shoppette and to predict the concentrations and extent of the contaminant plumes in the groundwater over time.

Dissolved BTEX compounds at the site are expected to continue to leach from contaminated soils containing fuel residuals, to dissolve from mobile LNAPL into the groundwater, and to migrate downgradient as a dissolved contaminant plume. In addition to the effects of mass transport mechanisms (volatilization, dispersion, diffusion, and adsorption), these dissolved contaminants will likely be removed from the groundwater system by destructive attenuation mechanisms, such as biodegradation. The effects of

these fate and transport processes on the dissolved BTEX plume will be investigated using the quantitative groundwater analytical data and the solute transport models. Data collection and analysis requirements are discussed in Section 3 of this work plan.

2.2.3 Potential Pathways and Receptors

Potential preferential contaminant migration pathways such as groundwater discharge points and subsurface utility corridors (artificial conduits) will be identified during the field work phase of this project. The primary potential migration path for contaminants at the BX Shoppette is from the residual LNAPL in contaminated soils and mobile LNAPL at the site into the groundwater, and from the groundwater to potential downgradient receptors via ingestion or incidental contact.

Shallow groundwater beneath the site flows toward the east. There are no known operating potable or nonpotable water wells (other than monitoring wells) located within 1 mile downgradient or crossgradient from the site. Surface drainage by overland flow from the site discharges into the adjacent surface drainages and flows into Ditch 25, north of the site. Shallow soil contamination at the site is located at the gasoline tank pit and fuel trench, and is not expected to impact surface water quality due to the asphalt cover.

The potential for exposure to contaminated groundwater originating from the site through ingestion is low because Base access is restricted and Base drinking water does not come from wells located downgradient from the site and within the surficial aquifer. Pavement at the site prevents surface water/soil contact. However, fuel vapors could migrate into the BX Shoppette building. There are four deep-aquifer potable- water wells located approximately 2.3 miles southeast of the Base that are used by the city of Blytheville. Site contaminants are not expected to migrate to any of these drinking water

wells. However, determining the potential impacts from shallow groundwater discharge into the adjacent drainage ditch will be of primary importance for assessing the feasibility of intrinsic remediation at the BX Shoppette and will be considered in greater detail once additional site data essential for the evaluation of intrinsic remediation have been collected.

SECTION 3

COLLECTION OF ADDITIONAL DATA

To complete the TS and to evaluate whether natural attenuation of fuel-related contaminants is occurring, additional site-specific hydrogeologic data will be collected. The physical and chemical hydrogeologic parameters listed below will be determined during the field work phase of the TS.

Physical hydrogeologic characteristics include:

- Depth from measurement datum to the groundwater surface in existing monitoring wells;
- Locations of potential groundwater recharge and discharge areas;
- Locations of downgradient wells and their uses;
- Hydraulic conductivity through slug tests, as required;
- Estimation of dispersivity, where possible;
- Stratigraphic analysis of subsurface media;
- Groundwater temperature; and
- Determination of extent and thickness of mobile- and residual-LNAPL.

Chemical hydrogeologic characteristics include:

- Dissolved oxygen (DO) concentrations;

- Specific conductance;
- pH;
- Chemical analysis of mobile LNAPL to determine mass fraction of BTEX; and
- Additional chemical analysis of groundwater and soil for the parameters listed in Table 3.1.

Field work described in this work plan in support of the TS will be completed in March 1996. The objective of field work will be to define the extent of residual and mobile LNAPL hydrocarbon contamination using CPT in conjunction with LIF testing and soil, groundwater, and mobile LNAPL sampling. Areas of residual and free-phase hydrocarbon contamination were sampled during field operations conducted in 1991, 1992, and 1995; however, additional LIF testing will be required during the upcoming field operations to better define the extent of residual and mobile LNAPL.

The following sections describe the procedures that will be followed when performing field investigations and collecting site-specific data. The CPT/LIF system is described in Section 3.1. Procedures for soil sample collection to verify CPT/LIF data are described in Section 3.1.2. Procedures for the installation of new monitoring points are described in Section 3.2. Procedures for sampling existing groundwater monitoring wells and newly installed groundwater monitoring points are described in Section 3.3, and procedures for the measurement of aquifer parameters (e.g., hydraulic conductivity) are described in Section 3.4.

TABLE 3.1
ANALYTICAL PROTOCOL FOR
GROUND WATER AND SOIL SAMPLES
BX SHOPPETTE
INTRINSIC REMEDIATION TS
EAKER AFB, ARKANSAS

MATRIX Analyte	METHOD	FIELD (F) OR ANALYTICAL LABORATORY (L)
WATER		
Total Iron	Colorimetric, Hach Method 8008 (or similar)	F
Ferrous Iron (Fe+2)	Colorimetric, Hach Method 8146 (or similar)	F
Ferric Iron (Fe+3)	Difference between total and ferrous iron	F
Manganese	Colorimetric, Hach Method 8034 (or similar)	F
Sulfide	Colorimetric, Hach Method 8131 (or similar)	F
Sulfate	Colorimetric, Hach Method 8051 (or similar)	F
Nitrate	Titrimetric, Hach Method 8039 (or similar)	F
Nitrite	Titrimetric, Hach Method 8507 (or similar)	F
Redox Potential	A2580B, direct-reading meter	F
Oxygen	Direct-reading meter	F
pH	E150.1/SW9040, direct-reading meter	F
Conductivity	E120.1/SW9050, direct-reading meter	F
Temperature	E170.1	F
Alkalinity (Carbonate [CO3-2] and Bicarbonate [HCO3-1])	Titrimetric, Hach Method 8221 (or similar)	F
Carbon Dioxide	CHEMetrics Method 4500	F
Nitrate	E300 or SW9056	L
Nitrite	E300 or SW9056	L
Chloride	E300 or SW9056	L
Sulfate	E300 or SW9056	L
Alkalinity	E150.1	L
Methane	RSKSOP 175 ^a	L
Total Organic Carbon	A5310C	L
Aromatic Hydrocarbons (Including Trimethylbenzene and Tetramethylbenzene)	SW8020	L
Total Hydrocarbons	SW8015, modified for gasoline-range organics	L
FREE PRODUCT		
Free Product	GS/MS, Direct Injection	L
SOIL		
Total Organic Carbon	SW9060	L
Moisture	ASTM D-2216	L
Aromatic Hydrocarbons	SW8020	L
Total Hydrocarbons	SW8015, modified for gasoline-range organics	L

^aRSKSOP = Robert S. Kerr Laboratory standard operating procedure.

3.1 CONE PENETROMETRY

Subsurface conditions at the site will be characterized using CPT coupled with LIF. Cone penetrometry is an expeditious and effective means of analyzing the stratigraphy of a site by measuring resistance against the conical probe of the penetrometer as it is pushed into the subsurface. Stratigraphy is determined from a correlation of the point stress at the probe tip and frictional stress on the side of the cone. Soil cores also are collected to correlate the CPT readings to the lithologies present at the site.

CPT will be conducted using the USACE's cone penetrometer truck. This equipment consists of an instrument probe that is forced into the ground using a hydraulic load frame mounted on a heavy truck, with the weight of the truck providing the necessary reaction mass. The penetrometer equipment is housed in a stainless steel, dual-compartment body mounted on a 43,000-pound, triple-axle Kenworth® truck chassis powered by a turbo-charged diesel engine. The weight of the truck and equipment is used as ballast to achieve the overall push capability of 39,000 pounds. This push capacity may be limited in tight soils by the structural bending capacity of the 1.40-inch outside-diameter (OD) push rods, rather than by the weight of the truck. The current 39,000-pound limitation is intended to minimize the possibility of push-rod buckling. Penetration force is supplied by a pair of large hydraulic cylinders bolted to the truck frame.

The penetrometer probe is of standard dimensions, having a 1.40-inch OD, a 60-degree conical point with sacrificial tip, and an 8.0-inch-long by 1.40-inch OD friction sleeve. Inside the probe, two load cells independently measure the vertical resistance against the conical tip and the side friction along the sleeve. Each load cell is a cylinder of uniform cross-section that is instrumented with four strain gauges in a full-bridge circuit. Forces are sensed by the load cells, and the data are transmitted from the probe

assembly via a cable running through the push tubes. The analog data are digitized, recorded, and plotted by computer in the penetrometry truck. A grout tube also runs down the push cylinder to allow the emplacement of cement grout in order to seal the CPT hole. The USACE CPT is not equipped to monitor pore pressure; therefore, the location of the water table will not be measured using the CPT apparatus. However, evaluation of point and sleeve stresses can often provide an estimated depth to groundwater. The penetrometer is usually advanced vertically into the soil at a constant rate of 2 cm/s, although this rate must sometimes be reduced, such as when hard layers are encountered. Penetration, dissipation, and resistivity data will be used to determine lithologic layering as it is encountered in the field.

The known propensity of aromatic hydrocarbons to fluoresce under ultraviolet wavelengths has allowed the use of LIF technology, in conjunction with CPT technology, to detect soil characteristics and hydrocarbon contamination simultaneously. The LIF is not capable of detecting chlorinated solvents. The LIF is only useful for more grossly contaminated areas with mobile LNAPL or significant residual contamination concentrations. The lower range of detection is greater than 100 mg/kg total hydrocarbons. The LIF system has a 0.25-inch sapphire window in the side of the cone that allows a laser to scan the soil for fluorescent compounds as the LIF penetrometer rod pushes through soil. Assuming that aromatic hydrocarbons are simultaneously solvenated with other fuel-hydrocarbon constituents, the magnitude of aromatic fluorescence is indicative of hydrocarbon contamination in a soil matrix. Fiber optic cables connected to the laser spectrometer and a 6-pair electrical conductor connected to the CPT data acquisition system, are routed through the interior of the push tubes to the CPT probe.

The basic components of the LIF instrument are a nitrogen laser, a fiber optic probe, a monochromator for wavelength resolution of the return fluorescence, a photomultiplier tube to convert photons into an electrical signal, a digital oscilloscope for waveform capture, and a control computer. The fiber optic probe for the cone penetrometer consists of delivery and collection optical fibers, a protective sheath, a fiber optic mount within the cone, and a 0.25-inch sapphire window (Figure 3.1).

The results of each CPT/LIF push will be available 2 or 3 minutes after the completion of each hole. Graphs showing cone resistance, sleeve friction, soil classification, fluorescence intensity, and wavelength will be plotted by USACE personnel at the conclusion of each penetration and presented to the Parsons ES field scientist in order to allow investigative decisions to be based on the most current information.

3.1.1 CPT/LIF Testing Strategy

The purpose of the CPT/LIF testing at the site is to determine subsurface stratigraphy and to better define the areal and vertical extent of residual fuel hydrocarbons in the unsaturated zone and free-phase hydrocarbons in the site groundwater. The CPT will be pushed from ground surface to below fluorescing contamination, refusal, or up to 60 feet bgs, depending on contaminant distribution and subsurface conditions. In order to define the edges of mobile LNAPL contamination, CPT/LIF points will be placed at the locations shown on Figure 3.2. The majority of the points will be used to better define the vertical and lateral extent of the mobile LNAPL layer that has been observed in monitoring well TW1105. Points will be placed at the estimated outer extent of the LNAPL to establish a known mobile LNAPL plume location. CPT/LIF points also will be placed closer or further away, as necessary, to define the extent of the layer. Other CPT/LIF sites are located downgradient from the site across the drainage ditch and will

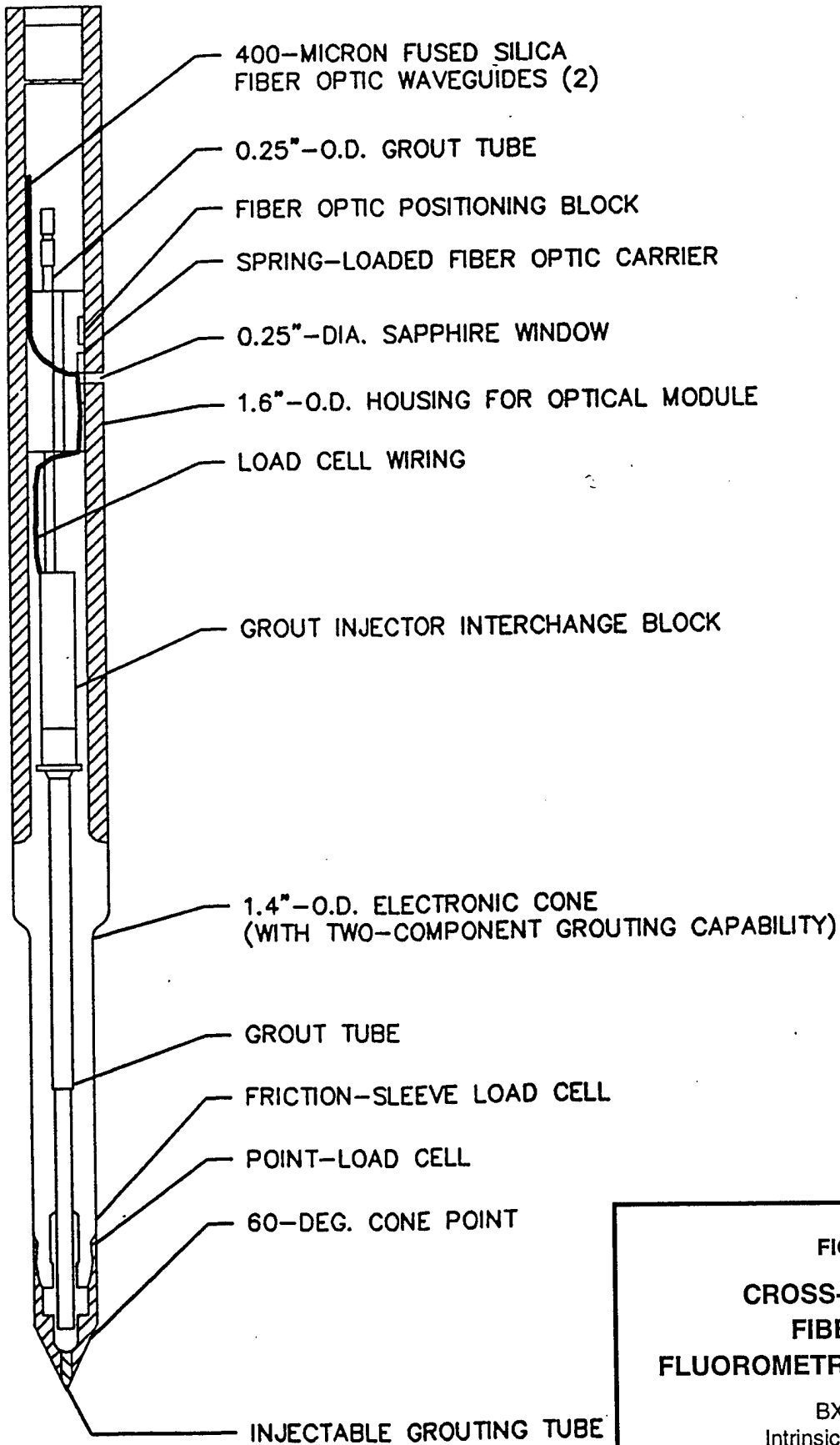

FIGURE 3.1
**CROSS-SECTION OF
 FIBER OPTIC
 FLUOROMETRY PENETROMETER**

BX Shoppette
 Intrinsic Remediation TS
 Eaker AFB, Arkansas

**PARSONS
 ENGINEERING SCIENCE, INC.**

Denver, Colorado

Sources: USGS, 1972.

- LEGEND**
- MW1101
 - TW1104
 - S
 - D
 - ⊕
 -

MONITORING WELL (CLOSED CIRCLE INDICATES GROUNDWATER SAMPLE LOCATION)

TEMPORARY WELL (CLOSED CIRCLE INDICATES GROUNDWATER SAMPLE LOCATION)

PROPOSED MONITORING POINT AND GROUNDWATER SAMPLING LOCATION (S=SHALLOW, D=DEEP)

PROPOSED SOIL OR LIF SAMPLING LOCATION

GROUNDWATER FLOW DIRECTION

SURFACE DRAINAGE

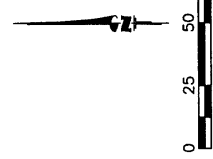
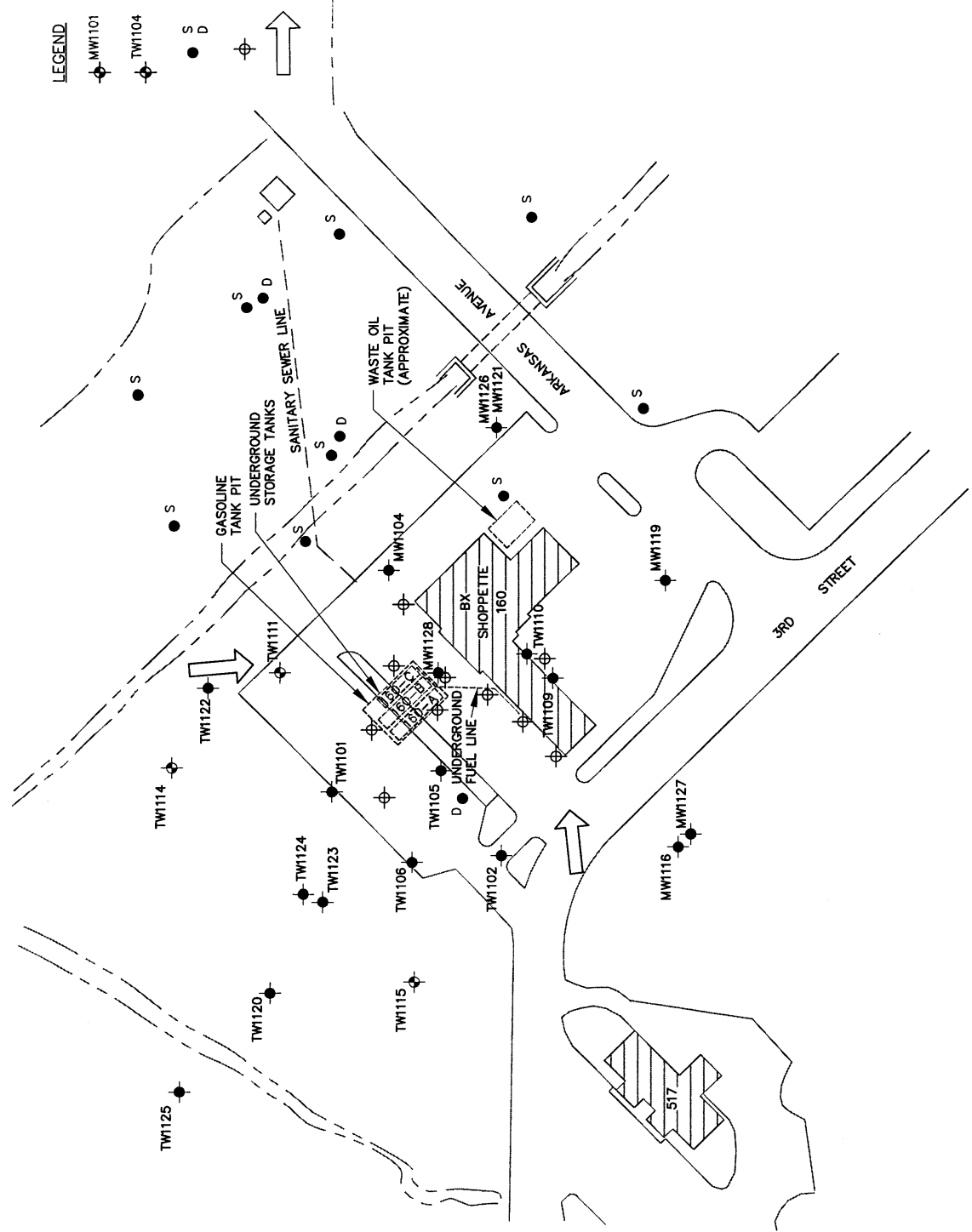

FIGURE 3.2

PROPOSED SOIL AND GROUNDWATER SAMPLING LOCATIONS

BX Shoppette
 Intrinsic Remediation TS
 Eaker AFB, Arkansas

PARSONS ENGINEERING SCIENCE, INC.
 Denver, Colorado



be used to install monitoring points to collect groundwater BTEX and electron acceptor data. One CPT point will be located north of the site to serve as a background monitoring point. The proposed CPT locations will be repositioned, as needed, based on data collected at the time of field sampling.

Base personnel will coordinate with the USACE to identify the location of all utility lines, USTs, fuel lines, and any other underground infrastructure prior to any CPT activities. All necessary digging permits will be obtained by Base and the USACE personnel prior to mobilizing to the field. Digging permits issued in 1995 for previous USACE (1995) work at the BX Shoppette may be used if Base authorities agree. Base personnel also will coordinate with USACE to acquire drilling and monitoring point installation permits for the proposed CPT/LIF locations indicated in Figure 3.2.

3.1.2 Soil Sampling and Analysis

To check the CPT soil classifications and to calibrate the LIF data, soil samples from discrete intervals will be collected at the site. Soil samples will be collected from varied soil units (if present) within source areas and visibly contaminated areas, at the fringe of the identified residual or mobile LNAPL hydrocarbon plume, and outside of the LNAPL plume. Soil samples will be collected at up to 13 locations. Figure 3.2 shows the locations for 10 proposed sampling locations. In addition, a minimum of three samples will be collected from background or uncontaminated downgradient locations for total organic carbon (TOC) analysis. These sampling locations will be determined by the field scientist based on field data collected using the CPT.

When soil samples are collected using the CPT, a Hoggen-Toggler[®] attachment for the CPT push rods will be used. A Hoggen-Toggler[®] sampler is a device used to collect undisturbed soil samples at any desired depth within the range of the driving apparatus.

The sampler is coupled to the penetrometer rod and pushed into the soil with the CPT truck. With the Hoggen-Toggler[®] cone in the closed position, soil is prevented from entering the sampling tube until the desired depth is achieved. When the sampler has been pushed to the depth at which the soil sample is to be taken, the sampling unit is raised a few inches and the Hoggen-Toggler[®] apparatus is opened. The open Hoggen-Toggler[®] is then pushed to fill with soil, then pulled from the ground as quickly as possible. The Hoggen-Toggler[®] sampling apparatus allows collection of 8-inch-long by 1-inch inside-diameter (ID) continuous samples. Recovery efficiencies for samples in saturated or sandy soils are often reduced, or the samples are compromised, because of spillage of the soil from the device after extraction. To mitigate this problem, soil samples will be compressed *in situ* with the penetrometer and Hoggen-Toggler[®] assembly to expel the pore water before extraction.

When the Hoggen-Toggler[®] sampling technique described above is ineffective or unable to efficiently provide sufficient soil volumes for the characterization of the site, soil samples will be obtained using a hand auger or similar method judged acceptable by the Parsons ES field scientist. Procedures will be modified, if necessary, to ensure good sample recovery.

Recovered soil will be placed in analyte-appropriate sample containers (Appendix A) and shipped to an approved analytical laboratory for analysis of BTEX, TOC, moisture content, and TPH by the analytical methods listed in Table 3.1. The lithology of recovered soil will be recorded for comparison and correlation with CPT results.

The Parsons ES field scientist will be responsible for observing all field investigation activities, maintaining a detailed descriptive log of all subsurface materials recovered during soil coring, photographing representative samples, and properly labeling and

storing samples. An example of the proposed geologic boring log form is presented in Figure 3.3. The descriptive log will contain the following information:

- Sample interval (top and bottom depth);
- Sample recovery;
- Presence or absence of contamination based on visual observations, odor, and photoionization detector (PID) headspace measurements;
- Lithologic description, including relative density, color, major textural constituents, minor constituents, porosity, relative moisture content, plasticity of fines, cohesiveness, grain size, structure or stratification, relative permeability, and any other significant observations; and
- Depths of lithologic contacts and/or significant textural changes measured and recorded to the nearest 0.1 foot.

3.1.3 CPT Locations and Datum Survey

The horizontal location of all CPT/LIF testing locations relative to established Base coordinates will be measured by a licensed surveyor. Horizontal coordinates will be measured to the nearest 0.1 foot. The elevation of the ground surface will also be measured to the nearest 0.1 foot relative to a USGS msl datum. Sample location and other relevant site information for the soil cores collected for verification purposes will be recorded by the Parsons ES field scientist.

GEOLOGIC BORING LOG

Sheet 1 of 1

BORING NO.: _____ CONTRACTOR: _____ DATE SPUD: _____
 CLIENT: AFCEE RIG TYPE: CPT DATE CMPL.: _____
 JOB NO.: 722450.15 DRLG METHOD: CPT ELEVATION: _____
 LOCATION: EAKER AFB BORING DIA.: _____ TEMP: _____
 GEOLOGIST: _____ DRLG FLUID: NONE WEATHER: _____
 COMMENTS: _____

Elev (ft)	Depth (ft)	Pro- file	US CS	Geologic Description	Sample	Sample	Penet	PID(ppm)	WKSPC PID(ppm)	TOTAL BTEX(ppm)	TPH (ppm)
					No.	Depth (ft)	Type				
	- 1 -										
	- 5 -										
	- 10 -										
	- 15 -										
	- 20 -										
	- 25 -										
	- 30 -										
	- 35 -										

NOTES

bgs - Below Ground Surface
 GS - Ground Surface
 TOC - Top of Casing
 NS - Not Sampled
 SAA - Same As Above

SAMPLE TYPE

D - DRIVE
 C - CORE
 G - GRAB

Water level drilled

FIGURE 3.3

GEOLOGIC BORING LOG

BX Shoppette
 Intrinsic Remediation TS
 Eaker AFB, Arkansas

PARSONS
ENGINEERING SCIENCE, INC.
 Denver, Colorado

3.1.4 Site Restoration

After sampling is complete, each CPT location will be restored as closely to its original condition as possible. Any test holes remaining open after extraction of the penetrometer rod will be sealed with hydrated bentonite chips, pellets, or grout to eliminate the creation or enhancement of contaminant migration pathways to the groundwater. Soil sampling using the CPT creates minor volumes of soil waste. The accumulated volume of soil waste generated during field activities will be collected in 55-gallon drums or buckets and disposed of at the soil landfarm located on Base.

3.1.5 Equipment Decontamination Procedures

The CPT push rods will be cleaned with potable water using the USACE CPT steam-cleaning system (rod cleaner) as the rods are withdrawn from the ground. A vacuum system located beneath the CPT truck will be used to recover rinseate. Use of this system results in nearly 100-percent recovery of steam-cleaning rinseate from the rod cleaner. Rinseate is generated only as the rods move past the cleaner, thereby minimizing liquid waste generation. Care will be taken not to apply the pressurized steam to the LIF module, which will be decontaminated by hand. Rinseate will be collected in 55-gallon drums. USACE personnel will arrange for final disposal of the containerized rinseate. USACE personnel are responsible for sampling the contents of the drums to identify any hazardous constituents before the drums are transported to an appropriate disposal facility. Other downhole and sampling equipment will be decontaminated by steam cleaning or by the procedures specified in Section 3.3.2.1.

Potable water to be used in CPT equipment cleaning, decontamination, or grouting will be obtained from one of the Base water supplies. Water use approval will be verified by contacting the appropriate facility personnel. The field scientist will make the final

determination as to the suitability of site water for these activities. Precautions will be taken to minimize any impact on the surrounding area that might result from decontamination operations.

3.2 PERMANENT MONITORING POINT INSTALLATION

To further characterize the hydrogeologic conditions of the shallow subsurface, up to 12 groundwater monitoring points may be installed at the site to supplement the existing site monitoring wells. The following sections describe the proposed monitoring point locations and completion intervals, monitoring point installation, monitoring point development, and equipment decontamination procedures.

3.2.1 Monitoring Point Locations and Completion Intervals

The locations of 12 proposed groundwater monitoring points are identified for the BX Shoppette site on Figure 3.2. The proposed locations for the new monitoring points were determined from a review of data gathered during previous site activities. Monitoring point locations were selected to provide hydrogeologic data necessary for successful implementation of the Bioplume II model and to monitor potential fuel hydrocarbon migration from the site. Monitoring point locations were selected to define three aspects of the site: 1) the areal extent of residual and mobile LNAPL contamination, 2) the horizontal and vertical distribution of dissolved BTEX, and 3) the hydrogeology and groundwater flow direction at the site. The proposed locations shown on Figure 3.2 may be modified in the field as a result of encountered field conditions and acquired field data.

Several shallow monitoring points are proposed to define the areal extent of contamination. Eight shallow monitoring points are proposed to be located east of the site to define the lateral extent of the dissolved contaminant migration. At least two deep

monitoring points will be located along the downgradient contaminant flow path to define the vertical extent of BTEX compounds. Another deep point will be placed adjacent to TW1105 to determine if any vertical migration of BTEX is occurring within the mobile LNAPL source area. The final proposed point will be located downgradient of the site near the intersection of the Arkansas and Third Street. Data from this monitoring point will provide additional information on electron acceptor concentrations and define the extent of the BTEX plume.

Screened intervals for shallow monitoring points will extend from approximately 1 foot above the water table to 2 feet below the water table. Deep points will be placed on the basis of lithology, or approximately 10 feet below the next shallowest monitoring point (in the absence of significant lithologic changes). All monitoring points will be installed with 1 meter of screen. The proposed screened intervals of 1 meter will help mitigate the dilution of water samples from potential vertical mixing of contaminated and uncontaminated groundwater in the monitoring point casing, and will give important information on the nature of vertical hydraulic gradients in the area. Adjustments of the depth and length of the screened interval of the monitoring points may be necessary in response to actual aquifer conditions and contaminant stratification identified during LIF/CPT testing.

3.2.2 Monitoring Point Installation Procedures

This section describes the procedures to be used for installation of new groundwater monitoring points. All new monitoring points will be constructed of 0.75-inch OD/0.5-inch ID polyvinyl chloride (PVC) casing placed with a CPT pushrod using equipment described in Section 3.1.

3.2.2.1 Pre-Placement Activities

All necessary digging, drilling, and groundwater monitoring point installation permits will be obtained prior to mobilizing to the field. In addition, all utility lines will be located, and proposed drilling locations will be cleared prior to any intrusive activities. Responsibilities for these permits and clearances are discussed in Section 3.1.1.

Water to be used in monitoring point installation and equipment cleaning will be obtained from one of the Base water supplies. Water use approval will be verified by contacting the appropriate facility personnel. The field scientist will make the final determination as to the suitability of water for these activities.

3.2.2.2 Groundwater Monitoring Point Installation

3.2.2.2.1 Monitoring Point Materials Decontamination

Monitoring point completion materials will be inspected by the field scientist and determined to be clean and acceptable prior to use. If not factory sealed, casing, screen, and casing plugs and caps will be cleaned prior to use with a high-pressure, steam/hot-water cleaner using approved water. Materials that cannot be cleaned to the satisfaction of the field scientist will not be used.

3.2.2.2.2 Monitoring Point Screen and Casing

Groundwater monitoring points will be installed by attaching 0.75-inch OD/0.5-inch ID PVC casing and screen to a sacrificial tip and threading the casing/screen through the penetrometer pushrod. As the pushrod is pressed into the ground, new 0.75-inch OD/0.5-inch ID PVC casing will be continuously attached until the desired depth is reached and a fully cased monitoring point is created. Data collection devices such as CPT and LIF will not be used during monitoring point placement; however, a CPT test will be performed at

each monitoring point location prior to monitoring point placement in order to select desired screen depths.

Monitoring point casing and screens will be constructed of flush-threaded, Schedule 40 PVC. The screens will be factory slotted with 0.01-inch openings. Casing joints will not be glued. The PVC top cap for monitoring points completed at or below grade will not be vented in order to minimize the potential for surface water entering the point.

The field scientist will verify and record the total depth of the monitoring point, the lengths of all casing sections, and the depth to the top of all monitoring point completion materials. All lengths and depths will be recorded to the nearest 0.1 foot. Monitoring point construction details will be noted on a Monitoring Point Installation Record form (Figure 3.4). This information will become part of the permanent field record for the site.

3.2.2.3 Above-Grade and At-Grade Well Completion

Each monitoring point will be completed with an at-grade protective cover. In areas where pavement is present, the at-grade cover will be cemented in place using concrete blended to the existing pavement; otherwise, a concrete pad will be installed around the monitoring point. The concrete immediately surrounding the monitoring point will be sloped gently away from the protective casing to facilitate runoff during precipitation events.

3.2.2.4 Monitoring Point Development

New monitoring points will be developed prior to sampling. Development removes sediment from inside the monitoring point casing and flushes fines from the portion of the formation adjacent to the monitoring point screen.

MONITORING POINT INSTALLATION RECORD

JOB NAME EAKER AIR FORCE BASE WELL NUMBER _____
 JOB NUMBER 722450.15 INSTALLATION DATE _____ LOCATION _____
 DATUM ELEVATION _____ GROUND SURFACE ELEVATION _____
 DATUM FOR WATER LEVEL MEASUREMENT _____
 SCREEN DIAMETER & MATERIAL _____ SLOT SIZE _____
 RISER DIAMETER & MATERIAL _____ BOREHOLE DIAMETER _____
 GRANULAR BACKFILL MATERIAL _____ ES REPRESENTATIVE _____
 DRILLING METHOD _____ DRILLING CONTRACTOR _____

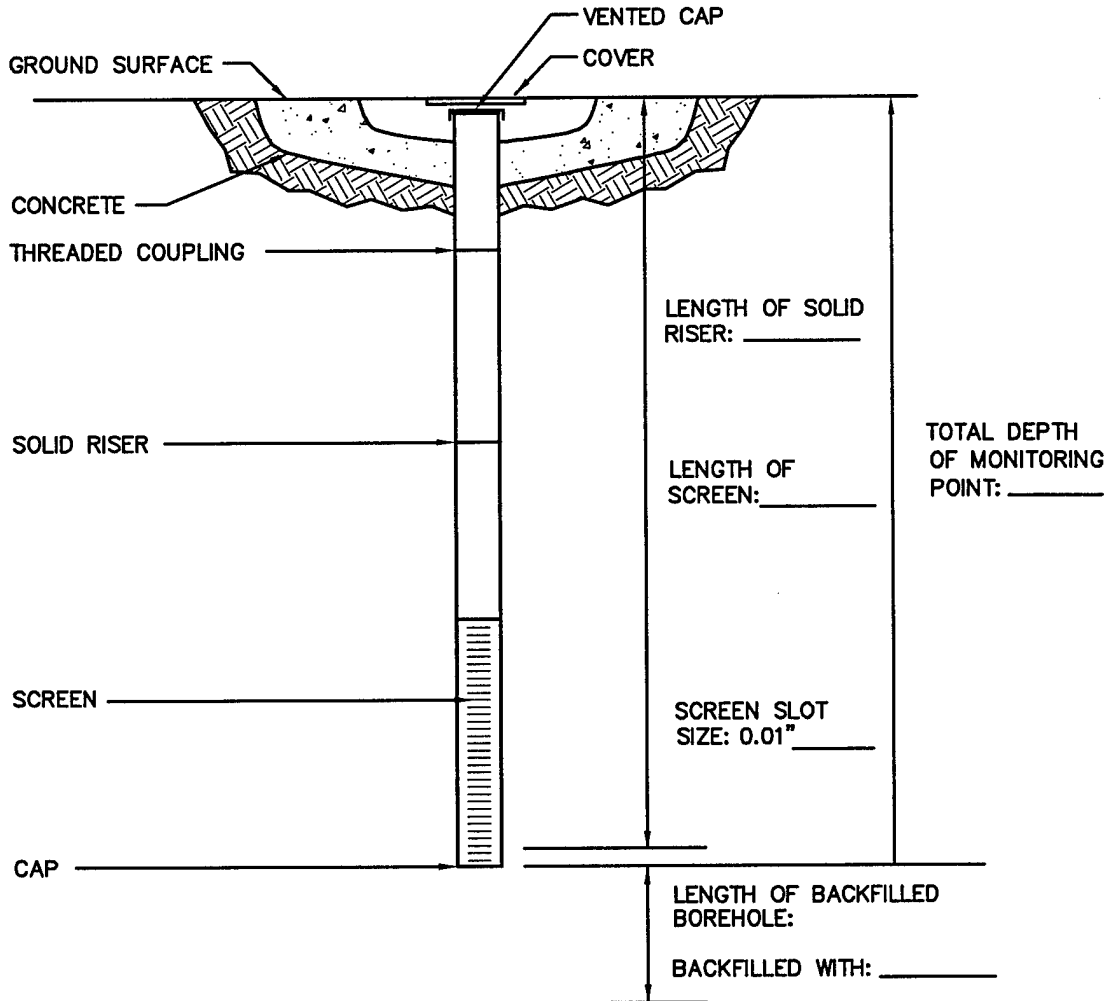

NOT TO SCALE

STABILIZED WATER LEVEL _____ FEET
 BELOW DATUM.

FIGURE 3.4

MONITORING POINT INSTALLATION RECORD

BX Shoppette
 Intrinsic Remediation TS
 Eaker AFB, Arkansas

**PARSONS
 ENGINEERING SCIENCE, INC.**

Denver, Colorado

Monitoring point development will be accomplished using a peristaltic pump with dedicated tubing provided by Parsons ES. The pump tubing will be regularly lowered to the bottom of the monitoring point so that fines which have accumulated in the bottom are agitated and removed from the monitoring point.

Development will be continued until a minimum 10 casing volumes of water has been removed from the monitoring point and until pH, temperature, specific conductivity, DO, and water clarity (turbidity) stabilize. If the water remains turbid, monitoring point development will continue until the turbidity of the water produced has been stable after the removal of several casing volumes.

A monitoring point development record will be maintained for each point. The monitoring point development record will be completed in the field by the field scientist. Figure 3.5 is an example of the monitoring point development record. Development records will include:

- Monitoring point number;
- Date and time of development;
- Development method;
- Predevelopment water level and monitoring point depth;
- Volume of water produced;
- Description of water produced;
- Postdevelopment water level and monitoring point depth; and
- Field analytical measurements, including pH and specific conductivity.

Job Number: 722450.15 Job Name: AFCEE Natural Attenuation
Location Eaker AFB - BX Shoppette by THMV Date
Well Number Measurement Datum

Pre-Development Information

Time (Start):

Water Level: Total Depth of Well:

Water Characteristics

Color Clear Cloudy
Odor: None Weak Moderate Strong
Any Films or Immiscible Material
pH Temperature(°F °C)
Specific Conductance(µS/cm)

Interim Water Characteristics

Gallons Removed
pH
Temperature (°F °C)
Specific Conductance(µS/cm)

Post-Development Information

Time (Finish):

Water Level: Total Depth of Well:

Approximate Volume Removed:

Water Characteristics

Color Clear Cloudy
Odor: None Weak Moderate Strong
Any Films or Immiscible Material
pH Temperature(°F °C)
Specific Conductance(µS/cm)

Comments:

FIGURE 3.5
MONITORING POINT
DEVELOPMENT RECORD

BX Shoppette
Intrinsic Remediation TS
Eaker AFB, Arkansas

PARSONS
ENGINEERING SCIENCE, INC.

Denver, Colorado

Sources: USGS, 1972.

Development waters from monitoring points will be collected in buckets at the site because low volumes of purge water are expected. Samples of the development water will be collected in 500- to 1,000-milliliter (mL) plastic or glass jars that are capped with foil and set at ambient temperatures for 15 minutes. A headspace reading of the development water sample will be taken with an organic vapor meter (OVM). Development water with a headspace reading less than 5 parts per million, volume (ppmv) will be released on the ground surface at the site. Development waters with organic vapor headspace readings above 5 ppmv will be collected and transported to the on-base landfarm for disposal.

3.2.2.5 Water Level Measurements

Water levels at existing monitoring wells and newly installed monitoring points will be measured within a short time period so that the water level data are comparable. The depth to water below the measurement datum will be measured to the nearest 0.01 foot using an electric water level probe.

3.2.2.6 Monitoring Point Location and Datum Survey

The location and elevation of the new monitoring points will be surveyed soon after point completion. The horizontal location will be measured relative to established Base coordinates. Horizontal coordinates will be measured to the nearest 0.1 foot. The elevation of the ground surface adjacent to the monitoring point casing and the measurement datum elevation (top of PVC casing) will be measured relative to the USGS msl datum. The ground surface elevation will be measured to the nearest 0.1 foot and the measurement datum, outer casing, and surveyor's pin (if present) elevation will be measured to the nearest 0.01 foot.

3.2.3 Site Restoration

After monitoring point installation and sampling is complete, each site will be restored around the finished monitoring point as closely as possible to its original condition. Both clean and contaminated development waters and sampling purge waters will be stored in 55-gallon drums or buckets. Development water will be disposed of as specified in Section 3.2.2.4.

3.3 GROUNDWATER SAMPLING

This section describes the scope of work required for collection of groundwater quality samples at existing groundwater monitoring wells, monitoring points, and well points. This section also details grab-sampling using peristaltic pumps inserted into the probe rods themselves to obtain single, discrete groundwater samples, if required. All groundwater samples will be obtained using a peristaltic pump and dedicated high-density polyethylene tubing (HDPE) where groundwater levels permit. In order to maintain a high degree of QC during this sampling event, the procedures described in the following sections will be followed.

Sampling will be conducted by qualified scientists and technicians trained in the conduct of groundwater sampling, records documentation, and chain-of-custody procedures. In addition, sampling personnel will have thoroughly reviewed this work plan prior to sample acquisition and will have a copy of the work plan available on site for reference.

The following list summarizes the activities that will occur during groundwater sampling:

- Assembly and preparation of equipment and supplies;

- Inspection of the monitoring well or monitoring point integrity including:
 - Protective cover, cap, and lock,
 - External surface seal and pad,
 - Monitoring point ca, and datum reference, and
 - Internal surface seal;
- Groundwater sampling, including
 - Water level and product thickness measurements,
 - Visual inspection of sample water,
 - Monitoring point casing evacuation, and
 - Sample collection;
- Sample preservation and shipment, including
 - Sample preparation,
 - Onsite measurement of physical parameters, and
 - Sample labeling;
- Completion of sampling records: and
- Sample disposition.

Detailed groundwater sampling and sample handling procedures are presented in following sections.

3.3.1 Groundwater Sampling Strategy

Groundwater samples will be collected from previously installed monitoring wells and from monitoring points installed during this project. The existing wells and proposed monitoring point locations for sampling are identified in the following sections.

With the exception of wells TW1114 and TW1115, existing monitoring wells TW1101 through MW1128 will be sampled. At monitoring wells MW1124, MW1125, MW1126, MW1127, and MW1128, groundwater samples will be collected from the medium-grained sand unit located approximately 26 feet bgs. Shallow groundwater samples will be collected from the remaining wells. In addition, samples will be collected from the newly installed monitoring points.

3.3.2 Preparation for Sampling

All equipment to be used for sampling will be assembled and properly cleaned and calibrated (if required) prior to arriving in the field. In addition, all record-keeping materials will be gathered prior to leaving the office.

3.3.2.1 Equipment Cleaning

All portions of sampling and test equipment that will contact the sample matrix will be thoroughly cleaned before each use. This includes the CPT rods, water level probe and cable, lifting line, test equipment for onsite use, and other equipment or portions thereof that will contact the samples. Based on the types of sample analyses to be conducted, the following cleaning protocol will be used:

- Wash with potable water and phosphate-free laboratory detergent (HP-II detergent solutions, as appropriate);
- Rinse with potable water;

- Rinse with distilled or deionized water;
- Rinse with isopropyl alcohol; and,
- Air dry the equipment prior to use.

Any deviations from these procedures will be documented in the field scientist's field notebook and on the Groundwater Sampling Record (Figure 3.6).

If precleaned disposable sampling equipment is used, the cleaning protocol specified above will not be required. Laboratory-supplied sample containers will be cleaned and sealed by the laboratory. The type of container provided and the method of container decontamination will be documented in the laboratory's permanent record of the sampling event.

3.3.2.2 Equipment Calibration

As required, field analytical equipment will be calibrated according to the manufacturers' specifications prior to field use. This applies to equipment used for onsite measurements of oxygen, carbon dioxide, pH, electrical conductivity, temperature, alkalinity, reduction/oxidation potential, sulfate, sulfide, nitrate, nitrite, ferrous iron (Fe^{2+}), total iron, ferric iron [$\text{Fe}^{3+} = (\text{total iron}) - \text{Fe}^{2+}$], and manganese.

3.3.3 Sampling Procedures

Special care will be taken to prevent contamination of the groundwater and extracted samples. The two primary ways in which sample contamination can occur are through contact with improperly cleaned equipment and through cross-contamination due to insufficient cleaning of equipment between wells and monitoring points. To prevent such contamination, the water level probe and cable used to determine static water levels and

GROUND WATER SAMPLING RECORD - MONITORING WELL _____
(number)

REASON FOR SAMPLING: Regular Sampling; Special Sampling;

DATE AND TIME OF SAMPLING: _____, 1996 _____ a.m./p.m.

SAMPLE COLLECTED BY: THMV of _____

WEATHER: _____

DATUM FOR WATER DEPTH MEASUREMENT (Describe): _____

MONITORING WELL CONDITION:

LOCKED: UNLOCKED

WELL NUMBER (IS - IS NOT) APPARENT _____

STEEL CASING CONDITION IS: _____

INNER PVC CASING CONDITION IS: _____

WATER DEPTH MEASUREMENT DATUM (IS - IS NOT) APPARENT _____

DEFICIENCIES CORRECTED BY SAMPLE COLLECTOR

MONITORING WELL REQUIRED REPAIR (describe): _____

Check-off

1 EQUIPMENT CLEANED BEFORE USE WITH _____
Items Cleaned (List): _____

2 PRODUCT DEPTH _____ FT. BELOW DATUM
Measured with: _____

WATER DEPTH _____ FT. BELOW DATUM
Measured with: _____

3 WATER-CONDITION BEFORE WELL EVACUATION (Describe):
Appearance: _____
Odor: _____
Other Comments: _____

4 WELL EVACUATION:
Method: _____
Volume Removed: _____
Observations: Water (slightly - very) cloudy
Water level (rose - fell - no change)
Water odors: _____
Other comments: _____

FIGURE 3.6

**GROUNDWATER
SAMPLING RECORD**

BX Shoppette
Intrinsic Remediation TS
Eaker AFB, Arkansas

**PARSONS
ENGINEERING SCIENCE, INC.**

Denver, -Colorado

total well depths will be thoroughly cleaned before and after field use and between uses at different sampling locations according to the procedures presented in Section 3.3.2.1. In addition to the use of properly cleaned equipment, dedicated HDPE tubing will be used at each sampling point, and a clean pair of new, disposable nitrile or latex gloves will be worn each time a different well or monitoring point is sampled. The following paragraphs present the procedures to be followed for groundwater sample collection from groundwater monitoring wells and monitoring points. These activities will be performed in the order presented below. Exceptions to this procedure will be noted in the sampler's field notebook and the groundwater sampling form.

3.3.3.1 Preparation of Location

Prior to starting the sampling procedure, the area around the existing wells and new monitoring points will be cleared of foreign materials, such as brush, rocks, and debris. These procedures will prevent sampling equipment from inadvertently contacting debris around the monitoring well/point.

3.3.3.2 Water Level and Total Depth Measurements

Prior to removing any water from the monitoring well or monitoring point, the static water level will be measured. An electric water level probe will be used to measure the depth to groundwater below the datum to the nearest 0.01 foot. After measuring the static water level, the water level probe will be slowly lowered to the bottom of the monitoring well/point, and the depth will be measured to the nearest 0.01 foot. Based on these measurements, the volume of water to be purged from the monitoring well/point will be calculated. If mobile LNAPL is encountered, the thickness of the LNAPL layer will be measured.

3.3.3.3 Purging Before Sampling

The volume of water contained within the monitoring well/monitoring point casing at the time of sampling will be calculated, and three times the calculated volume will be removed from the well/monitoring point. Clean and contaminated purge waters will be stored in 55-gallon drums or buckets. Water with a headspace reading less than 5 ppmv will be redistributed on the ground surface at the site. Water with headspace readings above 5 ppmv will be collected and transported to the on-Base landfarm for disposal

If a monitoring well/monitoring point is evacuated to a dry state during purging, the monitoring well/monitoring point will be allowed to recharge, and the sample will be collected as soon as sufficient water is present in the monitoring well or monitoring point to obtain the necessary sample quantity. Sample compositing or sampling over a lengthy period by accumulating small volumes of water at different times to obtain a sample of sufficient volume will not be allowed.

3.3.3.4 Sample Extraction

HDPE tubing and a peristaltic pump will be used to extract groundwater samples from the monitoring wells and well points. The tubing will be lowered through the well and 0.75-inch-outside diameter PVC monitoring point casing into the water gently to prevent splashing. The sample will be transferred directly into the appropriate sample container. The water will be carefully poured down the inner walls of the sample bottle to minimize aeration of the sample.

Unless other instructions are given by the analytical laboratory, sample containers will be completely filled so that no air space remains in the container. Excess water collected during sampling will be placed into 55-gallon drums used for monitoring well/monitoring point purge waters and transported for disposal by Base personnel to the on-Base facilities

3.3.4 Onsite Groundwater Parameter Measurement

As indicated on Table 3.1, many of the groundwater chemical parameters will be measured onsite by Parsons ES personnel. Some of the measurements will be made with direct-reading meters, while others will be made using of a Hach[®] portable colorimeter in accordance with specific Hach[®] analytical procedures. These procedures will be described in the following subsections.

All glassware or plasticware used in the analyses will have been cleaned prior to sample collection by thoroughly washing with a solution of Alconox[®] and water, and rinsing with deionized water and ethanol to prevent interference or cross contamination between measurements. If concentrations of an analyte are above the range detectable by the titrimetric method, the analysis will be repeated by diluting the groundwater sample with double-distilled water until the analyte concentration falls to a level within the range of the method. All rinseate and sample reagents accumulated during groundwater analysis will be collected in glass containers fitted with screw caps. These waste containers will be clearly labeled as to their contents and carefully stored for later transfer by Base personnel to the approved disposal facility.

3.3.4.1 Dissolved Oxygen (DO) Measurements

DO measurements will be made using a meter with a downhole oxygen sensor or a sensor in a flow-through cell. Measurements will be taken before and immediately

following groundwater sample acquisition. When DO measurements are taken in monitoring wells/points that have not yet been sampled, the existing monitoring wells/points will be purged until DO levels stabilize. DO measurements will be recorded on the groundwater sampling record (Figure 3.6)

3.3.4.2 pH, Temperature, and Specific Conductance

Because the pH, temperature, and specific conductance of a groundwater sample can change significantly within a short time following sample acquisition, these parameters will be measured in the field in unfiltered, unpreserved, "fresh" water collected by the same technique as the samples taken for laboratory analyses. The measurements will be made in a clean glass container separate from those intended for laboratory analysis, and the measured values will be recorded in the groundwater sampling record (Figure 3.6).

3.3.4.3 Carbon Dioxide Measurements

Carbon dioxide (CO₂) concentrations in groundwater will be measured in the field by experienced Parsons ES scientists via titrimetric analysis using CHEMetrics Method 4500 (0 to 250 mg/L as CO₂). Sample preparation and disposal procedures are the same as outlined at the beginning of Section 3.3.4.

3.3.4.4 Alkalinity Measurements

Alkalinity in groundwater helps buffer the groundwater system against acids generated through both aerobic and anaerobic biodegradation processes. Alkalinity of the groundwater sample will be measured in the field by experienced Parsons ES scientists via titrimetric analysis using USEPA-approved Hach[®] Method 8221 (0 to 5,000 mg/L as calcium carbonate).

3.3.4.5 Nitrate- and Nitrite-Nitrogen Measurements

Nitrate-nitrogen concentrations are of interest because nitrate can act as an electron acceptor during hydrocarbon biodegradation under anaerobic soil or groundwater conditions. Nitrate-nitrogen is also a potential nitrogen source for hydrocarbon-degrading bacteria biomass formation. Nitrite-nitrogen is an intermediate byproduct in both ammonia nitrification and in nitrate reduction in anaerobic environments.

Nitrate- and nitrite-nitrogen concentrations in groundwater will be measured in the field by experienced Parsons ES scientists via colorimetric analysis using a Hach® DR/700 Portable Colorimeter. Nitrate concentrations in groundwater samples will be analyzed after preparation with Hach® Method 8039 (0 to 30.0 mg/L nitrate). Nitrite concentrations in groundwater samples will be analyzed after preparation with USEPA-approved Hach® Method 8507 (0 to 0.35 mg/L nitrite).

3.3.4.6 Sulfate and Sulfide Sulfur Measurements

Sulfate in groundwater is a potential electron acceptor for fuel-hydrocarbon biodegradation in anaerobic environments, and sulfide is resultant after sulfate reduction. The Parsons ES scientist will measure sulfate and sulfide concentrations via colorimetric analysis with a Hach® DR/700 Portable Colorimeter after appropriate sample preparation. EPA-approved Hach® Methods 8051 (0 to 70.0 mg/L sulfate) and 8131 (0.60 mg/L sulfide) will be used to prepare samples and analyze sulfate and sulfide concentrations, respectively.

3.3.4.7 Total Iron, Ferrous Iron, and Ferric Iron Measurements

Iron is an important trace nutrient for bacterial growth, and different states of iron can affect the oxidation/reduction potential of the groundwater and act as an electron acceptor for biological metabolism under anaerobic conditions. Iron concentrations will be

measured in the field via colorimetric analysis with a Hach® DR/700 Portable Colorimeter after appropriate sample preparation. Hach® Method 8008 for total soluble iron (0 to 3.0 mg/L ferric + ferrous iron) and Hach® Method 8146 for ferrous iron (0 to 3.0 mg/L) will be used to prepare and quantitate the samples. Ferric iron will be quantitated by subtracting ferrous iron levels from total iron levels.

3.3.4.8 Manganese Measurements

Manganese is a potential electron acceptor under anaerobic environments. Manganese concentrations will be quantitated in the field using colorimetric analysis with a Hach® DR/700 Portable Colorimeter. EPA-approved Hach® Method 8034 (0 to 20.0 mg/L) will be used to prepare the samples for quantitation of manganese concentrations. Sample preparation and disposal procedures are outlined earlier in Section 3.3.4.

3.3.4.9 Reduction/Oxidation Potential

The reduction/oxidation (redox) potential of groundwater is an indicator of the relative tendency of a solution to accept or transfer electrons. Redox reactions in groundwater are usually biologically mediated; therefore, the redox potential of a groundwater system depends upon and influences rates of biodegradation. Redox potential can be used to provide real time data on the location of the contaminant plume, especially in areas undergoing anaerobic biodegradation. The redox potential of a groundwater sample taken inside the contaminant plume should have a redox potential somewhat less than that taken in the upgradient location.

The redox potential of a groundwater sample can change significantly within a short time following sample acquisition and exposure to atmospheric oxygen. As a result, this parameter will be measured in the field in unfiltered, unpreserved, "fresh" water collected by the same technique as the samples taken for laboratory analyses. The measurements

will be made as quickly as possible in a clean glass container separate from those intended for laboratory analysis.

3.3.5 Handling of Samples for Laboratory Analysis

This section describes the procedures for sample handling from the time of sampling until the samples arrive at the laboratory.

3.3.5.1 Sample Preservation

The analytical laboratory support personnel will add any necessary chemical preservatives prior to shipping the containers to the site. Samples will be prepared for transportation to the analytical laboratory by placing the samples in a cooler containing ice to maintain a shipping temperature of approximately 4 degrees centigrade (°C). Samples will be delivered to the analytical laboratory via overnight courier so that all sample holding times are met.

3.3.5.2 Sample Container and Labels

Sample containers and appropriate container lids will be provided by the analytical laboratory (see Appendix A). The sample containers will be filled as described in Section 3.3.3.2.4, and the container lids will be tightly closed. The sample label will be firmly attached to the container side, and the following information will be legibly and indelibly written on the label:

- Facility name;
- Sample identification;
- Sample type (e.g., groundwater);
- Sampling date;

- Sampling time;
- Preservatives added;
- Sample collector's initials; and
- Requested analyses.

3.3.5.3 Sample Shipment

After the samples are sealed and labeled, they will be packaged for transport to the mobile laboratory. The following packaging and labeling procedures will be followed:

- Package sample so that it will not leak, spill, or vaporize from its container;
- Cushion samples to avoid breakage; and
- Add ice to container to keep samples cool.

The packaged samples will be delivered by overnight courier to the analytical laboratory. Delivery will occur as soon as possible after sample acquisition.

3.3.5.4 Chain-of-Custody Control

After the samples have been collected, chain-of-custody procedures will be followed to establish a written record of sample handling and movement between the sampling site and the analytical laboratory. Each shipping container will have a chain-of-custody form completed in triplicate by the sampling personnel. One copy of this form will be kept by the sampling contractor after sample delivery to the analytical laboratory, and the other two copies will be retained at the laboratory. One of the laboratory copies will become a

part of the permanent record for the sample and will be returned with the sample analytical results. The chain-of-custody will contain the following information:

- Sample identification number;
- Sample collectors' printed names and signatures;
- Date and time of collection;
- Place and address of collection;
- Sample matrix;
- Chemical preservatives added;
- Analyses requested;
- Signatures of individuals involved in the chain of possession; and
- Inclusive dates of possession

The chain-of custody documentation will be placed inside the shipping container so that it will be immediately apparent to the laboratory personnel receiving the container, but will not be damaged or lost during transport. The shipping container will be sealed so that it will be obvious if the seal has been tampered with or broken.

3.3.5.5 Sampling Records

In order to provide complete documentation of the sampling event, detailed records will be maintained by the field scientist. At a minimum, these records will include the following information:

- Sample location (facility name);
- Sample identification;
- Sample location map or detailed sketch;
- Date and time of sampling;
- Sampling method;
- Field observations of
 - Sample appearance, and
 - Sample odor;
- Weather conditions;
- Water level prior to purging;
- Total monitoring well/monitoring point depth;
- Purge volume;
- Water level after purging;
- Monitoring well/point condition;
- Sampler's identification;
- Field measurements of pH, temperature, DO, and specific conductivity; and
- Any other relevant information.

Groundwater sampling information will be recorded on a groundwater sampling form. Figure 3.6 shows an example of the groundwater sampling record.

3.3.6 Laboratory Analyses

Laboratory analyses will be performed on all groundwater samples and the QA/QC samples described in Section 5. The analytical methods for this sampling event are listed in Table 3.1. Prior to sampling, arrangements will be made with the analytical laboratory to provide a sufficient number of appropriate sample containers for the samples to be collected. All containers, preservatives, and shipping requirements will be consistent with USEPA protocol or those reported in Appendix A of this plan.

Analytical laboratory support personnel will specify the necessary QC samples and prepare appropriate QC sample bottles. For samples requiring chemical preservation, preservatives will be added to containers by the laboratory prior to delivery to the site. Containers, ice chests with adequate padding, and cooling media may be sent by the laboratory to the site. Sampling personnel will fill the sample containers and return the samples to the laboratory.

3.4 AQUIFER TESTING

Aquifer Slug tests will be conducted on selected existing wells to estimate the hydraulic conductivity of unconsolidated sand and clay deposits at the site. This information is required to accurately estimate the velocity of groundwater and contaminants in the shallow saturated zone. A slug test is a single-well hydraulic test used to determine the hydraulic conductivity of an aquifer in the immediate vicinity of the tested well. Slug tests can be used for both confined and unconfined aquifers that have a transmissivity of less than 7,000 square feet per day (ft²/day). Slug testing can be

performed using either a rising head or a falling head test; at this site, both methods will be used in sequence.

3.4.1 Definitions

- **Hydraulic Conductivity (K).** A quantitative measure of the ability of porous material to transmit water; defined as the volume of water that will flow through a unit cross-sectional area of porous or fractured material per unit time under a unit hydraulic gradient.
- **Transmissivity (T).** A quantitative measure of the ability of an aquifer to transmit water. It is the product of the hydraulic conductivity and the saturated thickness.
- **Slug Test.** Two types of testing are possible: rising head and falling head tests. A slug test consists of adding a slug of water or a solid cylinder of known volume to the well to be tested or removing a known volume of water or cylinder and measuring the rate of recovery of water level inside the well. The slug of a known volume acts to raise or lower the water level in the well.
- **Rising Head Test.** A test used in an individual well within the saturated zone to estimate the hydraulic conductivity of the surrounding formation by lowering the water level in the well and measuring the rate of recovery of the water level. The water level may be lowered by pumping, bailing, or removing a submerged slug from the well.
- **Falling Head Test.** A test used in an individual well to estimate the hydraulic conductivity of the surrounding formation by raising the water level in the well by insertion of a slug or quantity of water, and then measuring the rate of drop in the water level.

3.4.2 Equipment

The following equipment will be used to conduct a slug test:

- Teflon®, PVC, or metal slugs;
- Nylon or polypropylene rope;
- Electric water level indicator;
- Pressure transducer/sensor;
- Field logbook/forms; and
- Automatic data recording instrument (such as the Hermit Environmental Data Logger®, In-Situ, Inc. Model SE1000B, or equivalent).

3.4.3 General Test Methods

Aquifer hydraulic conductivity tests (slug tests) are accomplished by either removal of a slug or quantity of water (rising head) or introduction of a slug (falling head), and then allowing the water level to stabilize while taking water level measurements at closely spaced time intervals.

Because hydraulic testing will be completed on existing wells, it will be assumed that the wells were properly developed and that water levels have stabilized. Slug testing will proceed only after multiple submerged pressure transducer measurements over time show that static water levels are in equilibrium. During the slug test, the water level change should be influenced only by the introduction (or removal) of the slug volume. Other factors, such as inadequate well development or extended pumping may lead to

inaccurate results; slug tests will not be performed on wells with free product. The field scientist will determine when static equilibrium has been reached in the well. The pressure transducer, slugs, and any other downhole equipment will be decontaminated prior to and immediately after the performance of each slug test using the procedures described in Section 3.3.2.1.

3.4.4 Falling Head Test

The falling head test is the first step in the two-step slug-testing procedure. The following steps describe procedures to be followed during performance of the falling head test.

1. Decontaminate all downhole equipment prior to initiating the test.
2. Open the well. Where wells are equipped with water-tight caps, the well should be unsealed at least 24 hours prior to testing to allow the water level to stabilize. The protective casing will remain locked during this time to prevent vandalism.
3. Prepare the Aquifer Slug Test Data Form (Figure 3.7) with entries for:
 - Borehole/well number,
 - Project number,
 - Project name,
 - Aquifer testing team,
 - Climatic data,
 - Ground surface elevation,

- Top of well casing elevation,
 - Identification of measuring equipment being used,
 - Page number,
 - Static water level, and
 - Date.
4. Measure the static water level in the well to the nearest 0.01 foot.
 5. Lower the decontaminated pressure transducer into the well and allow the displaced water to return to its static level. This can be determined by periodic water level measurements until the static water level in the well is within 0.01 foot of the original static water level or the submerged pressure-transducer indicates no pressure changes (indicating equilibrium).
 6. Lower the decontaminated slug into the well to just above the water level in the well.
 7. Turn on the data logger and quickly lower the slug below the water table, being careful not to disturb the pressure transducer. Follow the owner's manual for proper operation of the data logger.
 8. Terminate data recording when the water level stabilizes in the well. The well will be considered stabilized for termination purposes when it has recovered 80 to 90 percent from the initial slug.

3.4.5 Rising Head Test

After completion of the falling head test, the rising head test will be performed. The following steps describe the rising-head slug test procedure.

1. Measure the water level in the well to the nearest 0.01 foot to ensure that it has returned to the static water level.
2. Initiate data recording and quickly withdraw the slug from the well. Follow the owner's manual for proper operation of the data logger.
3. Terminate data recording when the water level stabilizes in the well, and remove the pressure transducer from the well and decontaminate. The well will be considered stabilized for termination purposes when it has recovered 80 to 90 percent from the initial slug.

3.4.6 Slug Test Data Analysis

Data obtained during slug testing will be analyzed using AQTESOLV™ and the method of Hvorslev (1951) for confined aquifers or the method of Bouwer and Rice (1976) and Bouwer (1989) for unconfined conditions.

SECTION 4

REMEDIAL OPTION EVALUATION AND TS REPORT

Upon completion of field work, numerical and analytical groundwater models will be used to determine the fate and transport of fuel hydrocarbons dissolved in groundwater at the site. Based upon model predictions of contaminant concentration and distribution through time, and upon potential receptor exposure pathways, the potential risk to human health and the environment will be assessed. If it is shown that intrinsic remediation of BTEX compounds at the sites is sufficient to reduce the potential risk to human health and the environment to acceptable levels, Parsons ES will recommend implementation of the intrinsic remediation option. If intrinsic remediation is chosen, Parsons ES will prepare site-specific, long-term monitoring plans that will specify the location of point-of-compliance monitoring wells and sampling frequencies.

If the intrinsic remediation remedial option is deemed inappropriate for use at this site, institutional controls such as groundwater or land use restrictions will be evaluated to determine if they will be sufficient to reduce the risk to human health and the environment to acceptable levels. If institutional controls are inappropriate, remedial options which could reduce risks to acceptable levels will be evaluated and the most appropriate remedial options will be recommended. Potential remedial options include, but are not limited to, mobile LNAPL recovery, groundwater pump-and-treat, enhanced biological treatment, bioventing, air sparging, and *in situ* reactive barrier walls. The

reduction in dissolved BTEX that should result from remedial activities will be used to produce new input files for the groundwater models. The models will then be used to predict the BTEX plume (and risk) reduction that should result from remedial actions.

Upon completion of modeling and remedial option selection, a TS report detailing the results of the modeling and remedial option selection will be prepared. This report will follow the outline presented in Table 4.1 and will contain an introduction, site description, identification of remediation objectives, description of remediation alternatives, an analysis of remediation alternatives, and the recommended remedial approach for the site. This report will also contain the results of the site characterization activities described herein and a description of the models developed for the site.

TABLE 4.1
EXAMPLE TS REPORT OUTLINE
BX SHOPPETTE
INTRINSIC REMEDIATION TS
EAKER AFB, ARKANSAS

INTRODUCTION

- Scope and Objectives
- Site Background

SITE CHARACTERIZATION ACTIVITIES

- Sampling and Aquifer Testing Procedures

PHYSICAL CHARACTERISTICS OF THE STUDY AREA

- Surface Features
- Regional Geology and Hydrogeology
- Site Geology and Hydrogeology
- Climatological Characteristics

NATURE AND EXTENT OF CONTAMINATION

- Source Characterization
- Soil Chemistry
 - Residual Contamination
 - Total Organic Carbon
- Ground Water Chemistry
 - LNAPL Contamination
 - Dissolved Contamination
 - Ground Water Geochemistry
 - Expressed Assimilative Capacity

GROUND WATER MODEL

- Model Description
- Conceptual Model Design and Assumptions
- Initial Model Setup
- Model Calibration
- Sensitivity Analysis
- Model Results
- Conclusions

COMPARATIVE ANALYSIS OF REMEDIAL ALTERNATIVES

- Remedial Alternative Evaluation Criteria
 - Long-Term Effectiveness
 - Implementability (Technical, Administrative)
 - Cost (Capital, Operating, Present Worth)
- Factors Influencing Alternatives Development
 - Program Objectives
 - Contaminant Properties
 - Site-Specific Conditions
- Brief Description of Remedial Alternatives
 - Intrinsic Remediation with Long-Term Monitoring
 - Other Alternatives
- Evaluation of Alternatives
- Recommended Remedial Approach

TABLE 4.1 (Concluded)
EXAMPLE TS REPORT OUTLINE
BX SHOPPETTE
INTRINSIC REMEDIATION TS
EAKER AFB, ARKANSAS

LONG-TERM MONITORING PLAN

- Overview
- Monitoring Networks
- Ground Water Sampling

CONCLUSIONS AND RECOMMENDATIONS

- APPENDICES: Supporting Data and Documentation**
Site-Specific Bioplume II Model Input and Results
-

SECTION 5

QUALITY ASSURANCE/QUALITY CONTROL

Field QA/QC procedures will include collection of field replicates and duplicates and rinseate, field and trip blanks; decontamination of all equipment that contacts the sample medium before and after each use; use of analyte-appropriate containers; and chain-of-custody procedures for sample handling and tracking. All samples to be transferred to the analytical laboratory for analysis will be clearly labeled to indicate sample number, location, matrix (e.g., groundwater), and analyses requested. Samples will be preserved in accordance with the analytical methods to be used, and water sample containers will be packaged in coolers with ice to maintain a temperature of as close to 4°C as possible.

All field sampling activities will be recorded in a bound, sequentially paginated field notebook in permanent ink. All sample collection entries will include the date, time, sample locations and numbers, notations of field observations, and the sampler's name and signature. Field QC samples will be collected in accordance with the program described below, and as summarized in Table 5.1.

QA/QC sampling will include collection and analysis of duplicate groundwater and replicate soil samples, rinseate blanks, field/trip blanks, and matrix spike samples. Internal laboratory QC analyses will involve the analysis of laboratory control samples (LCSs) and laboratory method blanks (LMBs). QA/QC objectives for each of these samples, blanks, and spikes are described below.

TABLE 5.1
QA/QC SAMPLING PROGRAM
BX SHOPPETTE
INTRINSIC REMEDIATION TS
EAKER AFB, ARKANSAS

QA/QC Sample Types	Collection/Analysis	Analytical Methods
Duplicates/Replicates	3 Groundwater and 2 Soil Samples (10%)	VOCs, TPH
Rinseate Blanks	1 Sample	VOCs
Field Blanks	1 Sample	VOCs
Trip Blanks	One per shipping cooler containing VOC samples	VOCs
Matrix Spike Samples	Once per sampling event	VOCs
Laboratory Control Sample	Once per method per medium	Laboratory Control Charts (Method Specific)
Laboratory Method Blanks	Once per method per medium	Laboratory Control Charts (Method Specific)

Only one rinseate sample will be collected at the site because dedicated tubing will eliminate the potential for cross-contamination due to improper decontamination of sampling tubing. Rinseate samples will consist of a sample of distilled water poured into or pulled through decontaminated or new sampling equipment and subsequently transferred into a sample container provided by the laboratory. Rinseate samples will be analyzed for VOCs only.

A field blank will be collected to assess the effects of ambient conditions in the field. The field blank will consist of a sample of distilled water poured into a laboratory-supplied sample container while sampling activities are underway. The field blank will be analyzed for VOCs.

A trip blank will be analyzed to assess the effects of ambient conditions on sampling results during the transportation of samples. The trip blank will be prepared by the laboratory. A trip blank will be transported inside each cooler which contains samples for VOC analysis. Trip blanks will be analyzed for VOCs.

Matrix spikes will be prepared in the laboratory and used to establish matrix effects for samples analyzed for VOCs. LCSs and LMBs also will be prepared internally by the laboratory and will be analyzed each day that samples from the site are analyzed. Samples will be reanalyzed in cases where the LCS or LMB are out of the control limits. Control charts for LCSs and LMBs will be developed by the laboratory and monitored for the analytical methods used.

SECTION 6

REFERENCES

- Borden, R.C., and Bedient, P.B. 1986. Transport of dissolved hydrocarbons influenced by oxygen limited biodegradation - theoretical development. *Water Resources Research*, vol. 22, no. 13. p. 1973-82.
- Bouwer, H., 1989, The Bouwer and Rice slug test - an update: *Ground Water*, 27(3), p. 304-309.
- Bouwer, H., and Rice, R.C., 1976, A slug test for determining hydraulic conductivity of unconfined aquifers with completely or partially penetrating wells: *Water Resources Research*, 12(3), p. 423-428.
- Bruce, L., Miller, T., and Hockman, B., 1991, Solubility versus equilibrium saturation of gasoline compounds - a method to estimate fuel/water partition coefficient using solubility or K_{oc} . In, A. Stanley (editor), *NWWAI/API Conference on Petroleum Hydrocarbons in Ground Water*: NWT/API, p. 571-582.
- Cline, P.V., Delfino, J.J., and Rao, P.S.C., 1991, Partitioning of aromatic constituents into water from gasoline and other complex solvent mixtures: *Environmental Science and Technology*: v. 17, no. 4, p. 227-231.
- Eaker Air Force Base (AFB), 1992, *Final Environmental Impact Statement, Disposal and Reuse of Eaker Air Force Base, Arkansas*, US Air Force, November.
- Engineering-Science, Inc., 1993, *Health and Safety Plan for the Bioplume Modeling Initiative*. Prepared for Air Force Center for Environmental Excellence, Environmental Restoration Division, USAF Contract F41624-92-D-8036.
- Halliburton NUS, 1992, *Installation Restoration Program (IRP) Draft Site Assessment Report for the BX Shoppette Underground Storage Tank Site, Eaker AFB, Arkansas*. June.
- Halliburton NUS, 1994, Unpublished BX Shoppette site data, Eaker AFB, Arkansas, June.
- Halliburton NUS, 1995, Unpublished BX Shoppette site data, Eaker AFB, Arkansas.
- Hvorslev, M. J., 1951, *Time Lag and Soil Permeability in Ground-Water Observations*: United States Corps of Engineers Waterways Experiment Station Bulletin 36, Vicksburg, Mississippi. 50p.
- Konikow, L. F., and Bredehoeft, J. D., 1978, Computer model of two-dimensional solute transport and dispersion in ground water: United States Geological Survey,

Techniques of Water Resources Investigations of the United States Geological Survey, Book 7, Chapter C2.

Lee, M.D. 1988. Bioremediation of aquifers contaminated with organic compounds. *CRC Critical Reviews in Environmental Control*, v. 18. p. 29-89.

Morell, F.M.M. and Hering, J.G., 1993, *Principals and Applications of Aquatic Chemistry*: John Wiley & Sons, Inc., New York.

US Army Corps of Engineers (COE), 1995, Site Characterization and Analysis Penetrometer System (SCAPS), BX Gas Station, Eaker AFB, Arkansas.

US Geological Survey (USGS), 1972, 7.5 Minute Quadrangle Map of Blytheville, Arkansas.

Wiedemeier, Todd H., Downey, Douglas C., Wilson, John T., Kampbell, Donald H., Miller, Ross N., and Hansen, Jerry E., 1995, *Draft Technical Protocol for Implementing the Intrinsic Remediation (Natural Attenuation) with Long-term Monitoring Option for Dissolved-phase Fuel Contamination in Ground Water*. Prepared by the Air Force Center for Environmental Excellence.

APPENDIX A

CONTAINERS, PRESERVATIVES, PACKAGING, AND SHIPPING

REQUIREMENTS FOR GROUNDWATER SAMPLES

TABLE A.1(Continued)
SAMPLE PACKAGING AND HANDLING REQUIREMENTS
BX Shoppette
Intrinsic Remediation TS
Eaker AFB, Arkansas

Matrix	Analysis	Method/Reference	Comments	Data Use	Recommended Frequency of Analysis	Sample Volume, Sample Container, Sample Preservation	Field or Fixed-Base Laboratory
Soil	Total organic carbon (TOC)	SW9060 modified for soil samples	Procedure must be accurate over the range of 0.5-15 percent TOC	Relatively high amounts of TOC may be indicative of a reducing environment and may indicate the need for analysis of electron acceptors associated with that environment; the rate of migration of petroleum contaminants in groundwater is dependent upon the amount of TOC in the saturated zone soil; the rate of release of petroleum contaminants from the source into groundwater is dependent (in part) on the amount of TOC in the vadose zone soil	At initial sampling	Collect 100 g of soil in a glass container with Teflon-lined cap; cool to 4°C	Fixed-base
Soil	Moisture	ASTM D-2216	Handbook method	Data are used to correct soil sample analytical results for moisture content (e.g., report results on a dry weight basis)	Each soil sampling round	Use a portion of soil sample collected for another analysis	Fixed-base
Soil	Grain size distribution	ASTM D422	Procedure provides a distribution of grain size by sieving	Data are used to infer hydraulic conductivity of aquifer, and are used in calculating sorption of contaminants	One time during life of project	Collect 250 g of soil in a glass or plastic container; preservation is unnecessary	Fixed-base
Soil gas	Carbon dioxide content of soil gas	Nondispersive infrared instrument operating over the range of approximately 0.1-15 percent	Soil gas carbon dioxide may be produced by the degradation of petroleum hydrocarbons	Data used to understand the carbon dioxide concentration gradient with depth and to infer the biological degradation of petroleum contaminants	Each sampling round	N/A	Field

TABLE A.1
SAMPLE PACKAGING AND HANDLING REQUIREMENTS
BX Shoppette
Intrinsic Remediation TS
Eaker AFB, Arkansas

Matrix	Analysis	Method/Reference	Comments	Data Use	Recommended Frequency of Analysis	Sample Volume, Sample Container, Sample Preservation	Field or Fixed-Base Laboratory
Soil	Volatile organics	Gas chromatography/mass spectrometry method SW8240.	Handbook method	Data is used to determine the extent of chlorinated solvent and aromatic hydrocarbon contamination, contaminant mass present, and the need for source removal	Each sampling round	Collect 100 g of soil in a glass container with Teflon®-lined cap; cool to 4°C	Fixed-base
Soil	Dehydrogenase enzyme activity (optional)	Colorimetric RKSOP-100	Reduction of added triphenyltetrazolium chloride by soil microbes is measured colorimetrically; analyze immediately	An indicator of the presence of soil microbes, which are necessary for bioremediation to occur	At the beginning of the project	Collect 100 g of soil in a glass container	Field
Soil	Aromatic hydrocarbons (benzene, toluene, ethylbenzene, and xylene [BTEX]; trimethylbenzene isomers)	Purge and trap gas chromatography (GC) method SW8020	Handbook method modified for field extraction of soil using methanol	Data is used to determine the extent of soil contamination, the contaminant mass present, and the need for source removal	Each sampling round	Collect 100 g of soil in a glass container with Teflon-lined cap; cool to 4°C	Fixed-base
Soil	Total hydrocarbons, volatile and extractable	GC method SW8015 [modified]	Handbook method; reference is the California LUFT manual	Data are used to determine the extent of soil contamination, the contaminant mass present, and the need for source removal	Each sampling round	Collect 100 g of soil in a glass container with Teflon-lined cap; cool to 4°C	Fixed-base

TABLE A.1 (Continued)
SAMPLE PACKAGING AND HANDLING REQUIREMENTS
 BX Shoppette
 Intrinsic Remediation TS
 Eaker AFB, Arkansas

Matrix	Analysis	Method/Reference	Comments	Data Use	Recommended Frequency of Analysis	Sample Volume, Sample Container, Sample Preservation	Field or Fixed-Base Laboratory
Soil gas	Oxygen content of soil gas	Electrochemical oxygen meter operating over the range of 0-25 percent of oxygen in the soil gas sample	The concentration of soil gas oxygen is often related to the amount of biological activity, such as the degradation of petroleum hydrocarbons; soil gas oxygen concentrations may decrease to the point where anaerobic pathways dominate	Data are used to understand the oxygen concentration gradient with depth and to determine the presence or absence of aerobic degradation processes	Each sampling round	N/A	Field
Soil gas	Methane content of soil gas	Total combustible hydrocarbon meter using a platinum catalyst with a carbon trap, and operating in the low parts per million volume (ppmv) range	Methane is a product of the anaerobic degradation of petroleum hydrocarbons	Soil gas methane can be used to locate contaminated soil and to determine the presence of anaerobic processes, see discussion of data use for methane in water	Each sampling round	N/A	Field
Soil gas	Fuel hydrocarbon vapor content of soil gas	Total combustible hydrocarbon meter operating over a wide ppmv range	Soil gas hydrocarbons indicate the presence of these contaminants in the soil column	Data used to understand the petroleum hydrocarbon concentration gradient with depth and to locate the most heavily contaminated soils	Each sampling round	N/A	Field
Water	Ferrous (Fe ²⁺)	Colorimetric A3500-Fe:D	Field only	May indicate an anaerobic degradation process due to depletion of oxygen, nitrate, and manganese	Each sampling round	Collect 100 mL of water in a glass container, acidify with hydrochloric acid per method	Field

TABLE A.1(Continued)
SAMPLE PACKAGING AND HANDLING REQUIREMENTS
BX Shoppette
Intrinsic Remediation TS
Eaker AFB, Arkansas

Matrix	Analysis	Method/Reference	Comments	Data Use	Recommended Frequency of Analysis	Sample Volume, Sample Container, Sample Preservation	Field or Fixed-Base Laboratory
Water	Ferrous (Fe ²⁺)	Colorimetric HACH Method # 8146	Alternate method; field only	Same as above	Each sampling round	Collect 100 mL of water in a glass container	Field
Water	Total Iron	Colorimetric HACH Method # 8008	Field only		Each sampling round	Collect 100mL of water in a glass container	Field
Water	Manganese	Colorimetric HACH Method # 8034	Field only		Each sampling round	Collect 100 mL of water in a glass container	Field
Water	Chloride	Mercuric nitrate titration A4500-Cl ⁻ C	Ion chromatography (IC) method E300 or method SW9050 may also be used	General water quality parameter used as a marker to verify that site samples are obtained from the same groundwater system	Each sampling round	Collect 250 mL of water in a glass container	Field
Water	Chloride	HACH Chloride test kit model 8-P	Silver nitrate titration	Same as above	Each sampling round	Collect 100mL of water in a glass container	Field
Water	Oxygen	Dissolved oxygen meter	Refer to method A4500 for a comparable laboratory procedure	The oxygen concentration is a data input to the Bioplume model; concentrations less than 1 mg/L generally indicate an anaerobic pathway	Each sampling round	Collect 300 mL of water in biochemical oxygen demand bottles; analyze immediately, alternately, measure dissolved oxygen <i>in situ</i>	Field
Water	Conductivity	E120.1/SW9050, direct reading meter	Protocols/Handbook methods	General water quality parameter used as a marker to verify that site samples are obtained from the same groundwater system	Each sampling round	Collect 100-250 mL of water in a glass or plastic container	Field
Water	Alkalinity	HACH Alkalinity test kit model AL AP MG-L	Phenolphthalein method	General water quality parameter used (1) as a marker to verify that all site samples are obtained from the same groundwater system; and (2) to measure the buffering capacity of groundwater	Each sampling round	Collect 100mL of water in glass container	Field

TABLE A.1 (Continued)
SAMPLE PACKAGING AND HANDLING REQUIREMENTS
BX Shoppette
Intrinsic Remediation TS
Eaker AFB, Arkansas

Matrix	Analysis	Method/Reference	Comments	Data Use	Recommended Frequency of Analysis	Sample Volume, Sample Container, Sample Preservation	Field or Fixed-Base Laboratory
Water	Alkalinity	A2320, titrimetric; E310.2, colorimetric	Handbook method	Same as above	Each sampling round	Collect 250 mL of water in a glass or plastic container, analyze within 6 hours	Field
Water	Nitrate (NO_3^{-1})	IC method E300 or method SW9056; colorimetric, method E353.2	Method E300 is a Handbook method; method SW9056 is an equivalent procedure Colorimetric	Substrate for microbial respiration if oxygen is depleted	Each sampling round	Collect up to 40 mL of water in a glass or plastic container, cool to 4°C; analyze within 48 hours	Fixed-base
Water	Nitrate (NO_3^{-1})	HACH method # 8039 for high range method # 8192 for low range HACH method #8040	Colorimetric	Same as above	Each sampling round	Collect 100mL of water in a glass container	Field
Water	Nitrite (NO)	HACH method #8040	Colorimetric	Substrate for microbial respiration if oxygen is depleted	Each sampling round	Collect 100mL of water in a glass container	Field
Water	Sulfate (SO_4^{-2})	IC method E300 or method SW9056	Method E300 is a Handbook method; method SW9056 is an equivalent procedure Colorimetric	Substrate for anaerobic microbial respiration	Each sampling round	Collect up to 40 mL of water in a glass or plastic container, cool to 4°C	Fixed-base
Water	Sulfate (SO_4^{-2})	HACH method # 8051	Colorimetric	Same as above	Each sampling round	Collect up to 40 mL of water in a glass or plastic container, cool to 4°C	Field
Water	Dissolved sulfide (S^{-2})	HACH method # 8131	Colorimetric	Product of sulfate-based anaerobic microbial respiration; analyze in conjunction with sulfate analysis	Each sampling round	Collect 100 mL of water in a glass container, analyze immediately	Field

TABLE A.1(Continued)
SAMPLE PACKAGING AND HANDLING REQUIREMENTS
BX Shoppette
Intrinsic Remediation TS
Eaker AFB, Arkansas

Matrix	Analysis	Method/Reference	Comments	Data Use	Recommended Frequency of Analysis	Sample Volume, Sample Container, Sample Preservation	Field or Fixed-Base Laboratory
Water	Ethane, ethene	RSKSOP-114 (cont'd)	Ethane and ethene are analyzed in addition to the other analytes only if chlorinated hydrocarbons are suspected of undergoing biological transformation	Ethane and ethene are products of the biotransformation of chlorinated hydrocarbons under anaerobic conditions. The presence of these chemicals may indicate that anaerobic degradation is occurring			
Water	Carbon dioxide	HACH test kit model CA-23 or CHEMetrics Method 4500	Titrimetric; alternate method	The presence of free carbon dioxide dissolved in groundwater is unlikely because of the carbonate buffering system of water, but if detected, the carbon dioxide concentrations should be compared with background to determine whether they are elevated; elevated concentrations of carbon dioxide could indicate an aerobic mechanism for bacterial degradation of petroleum	Each sampling round	Collect 100 mL of water in a glass container	Field

TABLE A.1 (Continued)
SAMPLE PACKAGING AND HANDLING REQUIREMENTS
BX Shoppette
Intrinsic Remediation TS
Eaker AFB, Arkansas

Matrix	Analysis	Method/Reference	Comments	Data Use	Recommended Frequency of Analysis	Sample Volume, Sample Container, Sample Preservation	Field or Fixed-Base Laboratory
Water	Aromatic hydrocarbons (BTEX, trimethylbenzene isomers)	Purge and trap GC method SW8020	Handbook method; analysis may be extended to higher molecular weight alkyl benzenes	Method of analysis for BTEX, which is the primary target analyte for monitoring natural attenuation; BTEX concentrations must also be measured for regulatory compliance; method can be extended to higher molecular weight alkyl benzenes; trimethylbenzenes are used to monitor plume dilution if degradation is primarily anaerobic	Each sampling round	Collect water samples in a 40 mL VOA vial; cool to 4°C; add hydrochloric acid to pH 2	Fixed-base
Water	Total hydrocarbons, volatile and extractable	GC method SW8015 [modified]	Handbook method; reference is the California LUFT manual	Data used to monitor the reduction in concentrations of total fuel hydrocarbons (in addition to BTEX) due to natural attenuation; data also used to infer presence of an emulsion or surface layer of petroleum in water sample, as a result of sampling	One time per year or as required by regulations	Volatile hydrocarbons—collect water samples in a 40 mL VOA vial; cool to 4°C; add hydrochloric acid to pH 2 Extractable hydrocarbons—collect 1 L of water in a glass container; cool to 4°C; add hydrochloric acid to pH 2	Fixed-base
Water	Polycyclic aromatic hydrocarbons (PAHs) (optional)	GC/mass spectroscopy method SW8270; high-performance liquid chromatography method SW8310	Analysis needed only for several samples per site	PAHs are components of fuel and are typically analyzed for regulatory compliance; data on their concentrations are not used currently in the evaluation of natural attenuation	At initial sampling and at site closure or as required by regulations	Collect 1 L of water in a glass container; cool to 4°C	Fixed-base

TABLE A.1(Continued)
SAMPLE PACKAGING AND HANDLING REQUIREMENTS
BX Shoppette
Intrinsic Remediation TS
Eaker AFB, Arkansas

Matrix	Analysis	Method/Reference	Comments	Data Use	Recommended Frequency of Analysis	Sample Volume, Sample Container, Sample Preservation	Field or Fixed-Base Laboratory
Water	Total fuel carbon (optional)	Purge and trap GC method SW8020 modified to measure all volatile aromatic hydrocarbons present in the sample	A substitute method for measuring total volatile hydrocarbons; reports amount of fuel as carbon present in the sample; method available from the U.S. EPA Robert S. Kerr Laboratory Handbook method	Data used to monitor the reduction in concentrations of total fuel hydrocarbons (in addition to BTEX) due to natural attenuation	At initial sampling and at site closure	Collect 40 mL of water in glass vials with Teflon-lined caps; add sulfuric acid to pH 2; cool to 4°C	Fixed-base
Water	Volatile Organics	GS/MS method SW8240		Method of analysis for chlorinated solvents and aromatic hydrocarbons for evaluation of comatabolic degradation; measured for regulatory compliance when chlorinated solvents are known site contaminants	Each sampling round	Collect water samples in a 40 mL VOA vial; cool to 4°C; add hydrochloric acid to pH 2	Fixed-base
Water	Dissolved organic carbon (DOC) (optional)	A5310 C	An oxidation procedure whereby carbon dioxide formed from DOC is measured by an infrared spectrometer. The minimum detectable amount of DOC is 0.05 mg/L	An indirect index of microbial activity	Each sampling round	Collect 100 mL of water in an amber glass container with Teflon-lined cap; preserve with sulfuric acid to pH less than 2; cool to 4°C	Fixed-base
Water	pH	E150.1/SW9040, direct reading meter	Protocols/Handbook methods	Aerobic and anaerobic processes are pH-sensitive	Each sampling round	Collect 100-250 mL of water in a glass or plastic container; analyze immediately	Field

TABLE A.1 (Continued)
SAMPLE PACKAGING AND HANDLING REQUIREMENTS
 BX Shoppette
 Intrinsic Remediation TS
 Eaker AFB, Arkansas

Matrix	Analysis	Method/Reference	Comments	Data Use	Recommended Frequency of Analysis	Sample Volume, Sample Container, Sample Preservation	Field or Fixed-Base Laboratory
Water	Temperature	E170.1	Field only	Well development	Each sampling round	N/A	Field
Water	Redox potential	A2580 B	Measurements are made with electrodes; results are displayed on a meter; samples should be protected from exposure to atmospheric oxygen	The redox potential of groundwater influences and is influenced by the nature of the biologically mediated degradation of contaminants; the redox potential of groundwater may range from more than 200 mV to less than -400 mV	Each sampling round	Collect 100-250 mL of water in a glass container, filling container from bottom; analyze immediately	Field

TABLE A.1(Continued)
SAMPLE PACKAGING AND HANDLING REQUIREMENTS

BX Shoppette
Intrinsic Remediation TS
Eaker AFB, Arkansas

NOTES:

1. "HACH" refers to the HACH Company catalog, 1990.
2. "A" refers to *Standard Methods for the Examination of Water and Wastewater*, 18th edition, 1992.
3. "E" refers to *Methods for Chemical Analysis of Water and Wastes*, U.S. Environmental Protection Agency, March 1979.
4. "Protocols" refers to the *AFCEE Environmental Chemistry Function Installation Restoration Program Analytical Protocols*, 11 June 1992.
5. "Handbook" refers to the *AFCEE Handbook to Support the Installation Restoration Program (IRP) Remedial Investigations and Feasibility Studies (RI/FS)*, September 1993.
6. "SW" refers to the *Test Methods for Evaluating Solid Waste, Physical, and Chemical Methods*, SW-846, U.S. Environmental Protection Agency, 3rd edition, 1986.
7. "ASTM" refers to the *American Society for Testing and Materials*, current edition.
8. "RSKSOP" refers to Robert S. Kerr (*Environmental Protection Agency Laboratory Standard Operating Procedure*).
9. "LUFT" refers to the state of California *Leaking Underground Fuel Tank Field Manual*, 1988 edition.
10. *International Journal of Environmental Analytical Chemistry*, Volume 36, pp. 249-257, "Dissolved Oxygen and Methane in Water by a Gas Chromatography Headspace Equilibration Technique," by D. H. Kambell, J. T. Wilson, and S. A. Vandegrift.

APPENDIX B
ADDITIONAL SITE DATA

APPENDIX B - 1A

SOIL BOREHOLE LOGS

BX SHOPPETTE

Source: Halliburton NUS 1992, 1994, and 1995.



FIELD LOG OF BORING

SHEET 1 OF 2

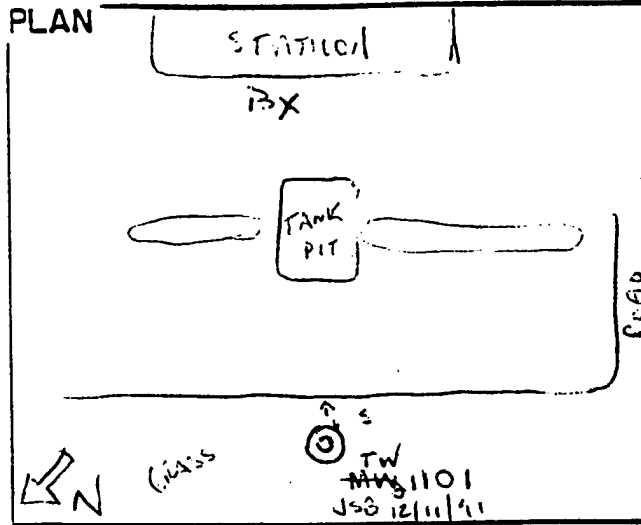

PROJECT EAKER 3K98 BA	BORING NO. TW1101
JOB NO. 3K98	LOGGED BY: JSS
PROJ. MGR. GVG	EDITED BY: BFN
DRILLING COMPANY: A.W POOL	
DRILL RIG TYPE: MOBILE B-61	
DRILLING METHOD: HOLLOW STEM AUGER	
DRILLERS NAME: VINCE BARAIZA	
TOTAL DEPTH (FT.) 30'	
TIME STARTED 0735	DATE 12/11/91
TIME COMPLETED 0827	DATE 12/11/91

GROUND-WATER CONDITION AT COMPLETION OF DRILLING
GROUNDWATER AT 19' ON CORE BARREL

BACKFILLED, SEE WELL DATE TIME COMPLETION FORM

WEATHER CONDITIONS
CLEAR, COOL, 40°

SURFACE ELEVATION

COMMENTS

SAMPLER TYPE	FEET DRIVEN	FEET RECOVERED	SAMPLE CONDITION	FIELD LABORATORY SAMPLE NUMBER	FIXED LABORATORY SAMPLE NUMBER	HNU SCAN (PPM)	LITHOLOGIC CODE	DEPTH (FEET)
LOW-SPLIT SPOON	0-2	2	VERY GOOD			0	CL	1
LOW-SPLIT SPOON	2-7	5	FAIR	E1101-1 (0745)	(25)	0	SW	2-7
LOW-SPLIT SPOON	7-12	5	EXCELLENT	E1101-2	JSS 12/11/91 (29) (0750)	30	CL	8-12

GRASS AT SURFACE

SILTY CLAY DK BROWN, MOIST
 ABUNDANT ORGANICS; TL SAND
 0-2'

SAND: MED GRAINED, WELL SORTED, BROWN -
 RUST COLORED, IRON-STAINING - VERY
 EVIDENT 2-6.5 MOIST

CLAY; VERY MOIST, PLASTIC, SOFT
 GREY - DK GREY; MINOR SILT
 6.5 - 30.0'

CLAY AS ABOVE; FEEL COOL

FIELD LOG OF BORING (CONT'D.)

SHEET 2 OF 2

SAMPLER TYPE	FEET DRIVEN	FEET RECOVERED	SAMPLE CONDITION	FIELD LAB. SAMPLE NO.	FIXED LAB. SAMPLE NO.	HNUSCAN (PPM)	LITHOLOGIC CODE	DEPTH (FEET)	PROJECT	BORING NO.
									EAKER	TW1101
									JOB NO. 3K98	
						50		11		
						4		12		
						2	CL #	13		CLAY AS ABOVE; MINOR SILT
						5		14		RUST-LT GREY; MOTTLED, TRACE
						0		15		MINOR ORGANICS (WOOD FRAGS) OR OXIDE
						0		16		SLIGHT FUEL ODR
						0		17		
						0		18		water on barrel @ 19'
						0		19		
						0	CL #	20		CLAY AS ABOVE;
						0		21		
						0		22		Driller will put on solid auger and
						0		23		drill to 30' to set well
						0		24		
						0		25		O.D. OF AUGER = 1 1/4"
						0		26		
						0		27		DRILLER REPORTS DRILLING CLAY TO 30'
						0		28		
						0		29		30'
						0		30		TD REACHED @ 0827
						0		1		
						0		2		
						0		3		
						0		4		
						0		5		
						0		6		
						0		7		
						0		8		
						0		9		
						0		10		

NOTES:

CONT & PLT
SPOON

CONT & PLT
SPOON

STRAIGHT
AUGER;
22-30

5

5

1

5

5

1

EXCELLENT

EXCELLENT

1

E1101-3

E1101-4

1

(215')

(19')

1

0802

0812

1

50

0

1

CL #

CL #

1

11

12

13

14

15

16

17

18

19

20

21

22

23

24

25

26

27

28

29

30

1

2

3

4

5

6

7

8

9

10

11

12

13

14

15

16

17

18

19

20

21

22

23

24

25

26

27

28

29

30

1

2

3

4

5

6

7

8

9

10

11

12

13

14

15

16

17

18

19

20

21

22

23

24

25

26

27

28

29

30



FIELD LOG OF BORING

SHEET 1 OF 2

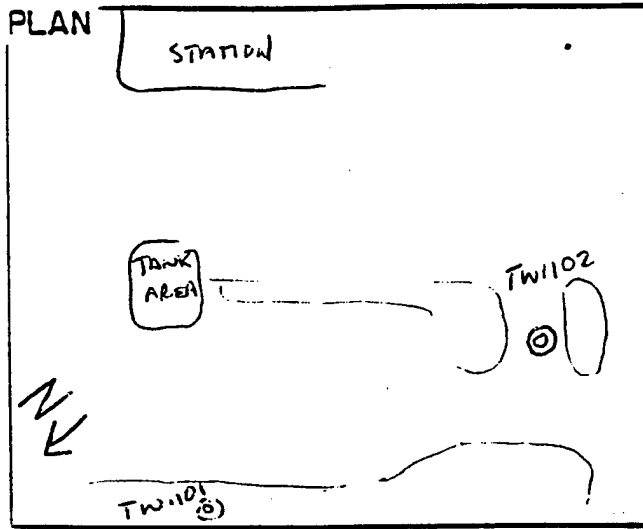

PROJECT EAKER 3K98 BX	BORING NO. TW1102
JOB NO. 3K98	LOGGED BY: JSB
PROJ. MGR. GVG	EDITED BY: BEN
DRILLING COMPANY: AW POOL	
DRILL RIG TYPE: MOBILE B-61	
DRILLING METHOD: Hollow Stem Auger	
DRILLERS NAME: V. BARAZZA	
TOTAL DEPTH (FT.) 30	
TIME STARTED 0945	DATE 12/11/91
TIME COMPLETED 1238	DATE 12/11/91

GROUND-WATER CONDITION AT COMPLETION OF DRILLING
Saturated zone 7.5' and 18'

BACKFILLED, TIME - DATE - SEE COMPLETION F

WEATHER CONDITIONS
CLEAR, 50°, S.L. BREEZE

SURFACE ELEVATION

COMMENTS ASPHALT AS SURFACE

SAMPLER TYPE	FEET DRIVEN	FEET RECOVERED	SAMPLE CONDITION	FIELD LABORATORY SAMPLE NUMBER	FIXED LABORATORY SAMPLE NUMBER	HNU SCAN (PPM)	LITHOLOGIC CODE	DEPTH (FEET)
STRAIGHT AUGER	0-2	20	1	1	1	1	1	1
CONTINUOUS SPLIT SPOON	2-7	5	EXCELLENT	E1102-1 (3)	@1002	5	CL	2
CONT SPLIT SPOON	7-12	5	EXCELLENT	E1102-2 (11)	@1011	7	CL	3
								4
								5
								6
								7
								8
								9
								10

Fill: clay, dark black to gray moist w/ some small gravel clasts

Clay, brown, moist medium stiff plastic w/ some silt, trace of sand

SAND STRINGER @ 7-7.5'; SATURATED w/ WATER

CLAY; BROWN. MOIST, SOFT-MD. STIFF PLASTIC. SOME SILT. MOTTLED w/ REDDISH-GRAY MOTTLES.

JSB 12/11/91

FIELD LOG OF BORING (CONT'D.)

SHEET 2 OF 2

SAMPLER TYPE	FEET DRIVEN	FEET RECOVERED	SAMPLE CONDITION	FIELD LAB. SAMPLE NO.	FIXED LAB. SAMPLE NO.	HMUSCAN (PPM)	LITHOLOGIC CODE	DEPTH (FEET)	PROJECT	BORING NO.
									EAKER BX	TW1102
									JOB NO. 3K98	
								11		CLAY AS ABOVE
								12		
								13		CLAY AS ABOVE; MED. STIFF - STIFF
								14		PLASTIC. DARK BROWN THAN ABOVE
								15		
							CH	16		BARREL WET AT 18'
								17		
								18		CLAY AS ABOVE; SDPT - MED. STIFF - STIFF
								19		AT BOTTOM; SOME SILT; MOTTLED BROWN-GREY
								20		RED BROWN.
								21		
								22		DRILLER WILL INSERT CENTER BIT TO
								23		FINISH HOLE -
								24		
								25		
								26		
								27		
								28		
								29		
								30		TD = 30
								1		
								2		
								3		
								4		
								5		
								6		
								7		
								8		
								9		
								0		

NOTES:





FIELD LOG OF BORING

SHEET 1 OF 2

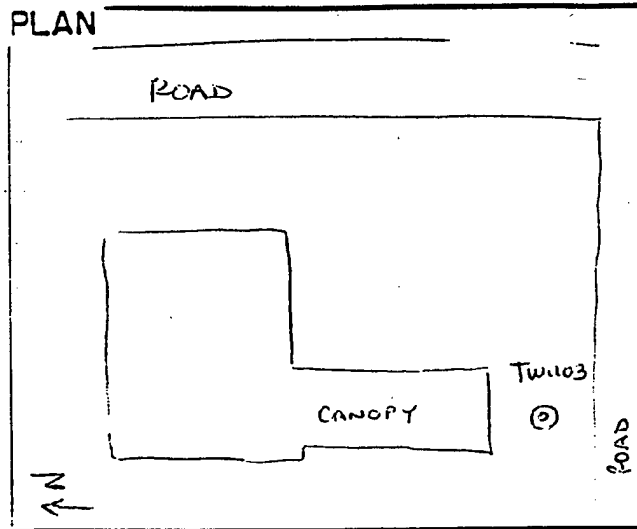

PROJECT BAKER BX SHOPPETTE	BORING NO. TW1103
JOB NO. 3K98	LOGGED BY: JSB
PROJ. MGR. GVG	EDITED BY: BFN
DRILLING COMPANY: AWPool	
DRILL RIG TYPE: MOBILE B-61	
DRILLING METHOD: HOLLOW STEM AUGER	
DRILLERS NAME: V. BARRAZA	
TOTAL DEPTH (FT.) 30	
TIME STARTED 1240	DATE 12/11/91
TIME COMPLETED 1335	DATE 12/11/91

SAMPLER TYPE	FEET DRIVEN	FEET RECOVERED	SAMPLE CONDITION	FIELD LABORATORY SAMPLE NUMBER	FIXED LABORATORY SAMPLE NUMBER	HNU SCAN (PPM)	LITHOLOGIC CODE	DEPTH (FEET)
STRAIGHT AUGER	0-2	0	-	-	-	-		1
CONTINUOUS SPLIT SPOON 2-7	5	3	GOOD	E1103-1 (3') @ 1302	E11-SU-TW1103A (3')	250	CL	2
CONT SPLIT SPOON 7-12	5	5	GOOD	E1103-2 (10') @ 1304	E11-SU-TW1103B (10') @ 1306	300	CH	8
						200		9
						200		10

GROUND-WATER CONDITION AT COMPLETION OF DRILLING	
BACKFILLED, TIME 1330	DATE 1/8/92
WEATHER CONDITIONS WARM 60°, SUNNY, LT BREEZE	
SURFACE ELEVATION	
COMMENTS ASPHALT AT SURFACE	
CLAY, (GREY-BROWN), SOME SILT, TR SD, MOTTLED, MOIST, STIFF; PRODUCT OVER 0.5 - 4.5	
SD (± 5') MED-FINE GRAINED, WELL-SORT. W/SOME GRAVEL, GREY 4.5-7	
CLAY AS ABOVE, GREY-BROWN w/OXIDE	
POSSIBLES MOTTLED: STIFF MED-SHA	
PLASTIC, TRACE SILT	



FIELD LOG OF BORING

SHEET 1 OF 2

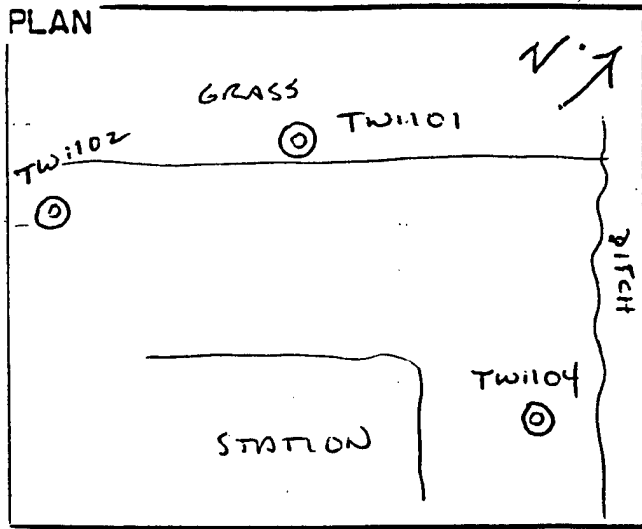

PROJECT EAKER BX	BORING NO. TW1104
JOB NO. 3K98	LOGGED BY: JSB
PROJ. MGR. GVG	EDITED BY: BFN
DRILLING COMPANY: AWPOL	
DRILL RIG TYPE: MOBILE B-61	
DRILLING METHOD: HOLLOW-STEM AUGER	
DRILLERS NAME: V. BARRAZA	
TOTAL DEPTH (FT.) 30	
TIME STARTED 12/11/91	DATE 12/11/91
TIME COMPLETED 1500	DATE 12/11/91

GROUND-WATER CONDITION AT COMPLETION OF DRILLING
SATURATED ZONE 8.5' and ± 19'

BACKFILLED, TIME _____ DATE _____ (SEE COMPLETION FORM)

WEATHER CONDITIONS
CLEAR, WARM 60°

SURFACE ELEVATION _____

COMMENTS ASPHALT AT SURFACE

FILL TO 2' GRAVELLY CLAY
0-2 FILL

CLAY: DK BROWN - BROWN; VERY MOIST
MED. STIFF, PLASTIC; TR SILT + SD.

2-8 CLAY

CLAY, BROWN; VERY MOIST; MED. STIFF
PLASTIC; TR SILT + SD; MOTTLED
GREENISH-GRAY TO RUST COLORED;
SDZ ZONE 8-8.5'

SAMPLER TYPE	FEET DRIVEN	FEET RECOVERED	SAMPLE CONDITION	FIELD LABORATORY SAMPLE NUMBER	FIXED LABORATORY SAMPLE NUMBER	HNU SCAN (PPM)	LITHOLOGIC CODE	DEPTH (FEET)
STRAIGHT AUGER 0-2	2	1					GC	0-2
CONTINUOUS SPLIT SPOON 2-7'	5	5	EXCELLENT			0	CLAY	2-7
CONTINUOUS SPLIT SPOON 7-12	5	5	EXCELLENT	E1104-1(8')	1455	6	SC/SW	7-12

FIELD LOG OF BORING (CONT'D.)

SHEET 2 OF 2

PROJECT EAKER BX		BORING NO. TW1104							
JOB NO. 3K98									
SAMPLER TYPE	FEET DRIVEN	FEET RECOVERED	SAMPLE CONDITION	FIELD LAB. SAMPLE NO.	FIXED LAB. SAMPLE NO.	HNUSCAN (PPM)	LITHOLOGIC CODE	DEPTH (FEET)	
CONTINUOUS SPLIT SPOON 12-17	5	5	EXCELLENT	-	-	-	CL CH	11	8.5-12
								12	CLAY AS ABOVE
								13	
								14	CLAY AS ABOVE; SILTY CLAY ZONE
								15	13-13.5'
								16	
CONTINUOUS SPLIT SPOON 17-22	5	5	EXCELLENT	E1104-2 (20')	@1509	-	SC	17	
								18	CLAY AS ABOVE: LT BROWN BELOW
								19	18'; ^{JKB} SANDIER ZONE
								20	20-21.5'
								21	
								22	SATURATED AT 19'
								23	
								24	
								25	
								26	
								27	
								28	
								29	
								30	TD = 30
								1	
								2	
								3	
								4	
								5	
								6	
								7	
								8	
								9	
								0	

NOTES:

No BARREL CAN FROM
22 TO 30'



FIELD LOG OF BORING

SHEET 2 OF 2

PLAN

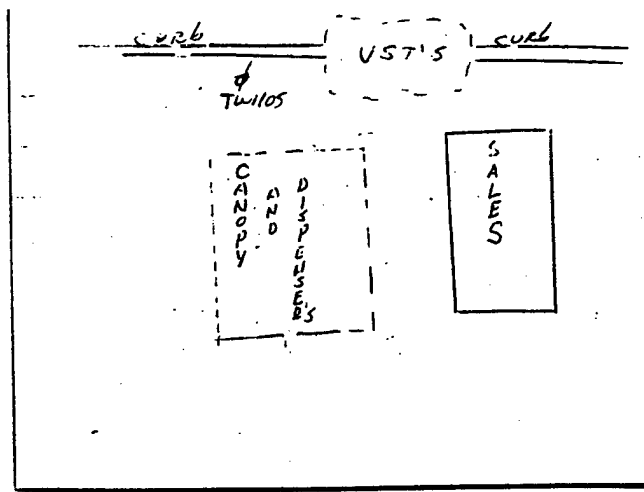

PROJECT	BORING NO.
EAKER: BX SITE	TW1105
JOB NO. 3K98	LOGGED BY: BFN
PROJ. MGR. GYG	EDITED BY: JSS
DRILLING COMPANY: Pool	
DRILL RIG TYPE: mobile B61	
DRILLING METHOD: Hellawster Augers	
DRILLERS NAME: V. Barrozza	
TOTAL DEPTH (FT.) 25	
TIME STARTED 0725	DATE 12/13/91
TIME COMPLETED 0803	DATE 12/13/91

GROUND-WATER CONDITION AT COMPLETION OF DRILLING
sat water at 215 feet

BACKFILLED, TIME - DATE - (SEE COMPLETION FORM)

WEATHER CONDITIONS
cloudy, cool 48°F

SAMPLER TYPE	FEET DRIVEN	FEET RECOVERED	SAMPLE CONDITION	FIELD LABORATORY SAMPLE NUMBER	FIXED LABORATORY SAMPLE NUMBER	HNU SCAN (PPM)	LITHOLOGIC CODE	DEPTH (FEET)
5' SPLIT BARREL	5.0	2.7	FAIR	E11TW05-1	-	75000	SW	1
5' SPLIT BARREL	5.0	5.0	Good	E11TW05-2	-	75000	SC	8

SURFACE ELEVATION

COMMENTS

Asphalt at surface
 0.0 to 0.2'

Fill: Gravel clast mixed some fines 0.2 to 1.0'

Fill: Sand: medium to coarse
 scummed, loose, moist
 non-plastic, strong hydrocarbon odor
 1.0 - 7.5

* Original soil
 Sandy Clay / clayey sand: grayish brown, sand is fine grained,
 slightly silted, moist, medium
 silt, slightly plastic.
 7.5 to 13.0'

FIELD LOG OF BORING (CONT'D.)

SHEET 2 OF 2

SAMPLER TYPE	FEET DRIVEN	FEET RECOVERED	SAMPLE CONDITION	FIELD LAB. SAMPLE NO.	FIXED LAB. SAMPLE NO.	HNUSCAN (PPM)	LITHOLOGIC CODE	DEPTH (FEET)	PROJECT	BORING NO.
									EAKER PFB	
									JOB NO. 3K98	E11T405
						2500	SC	1		
								2		
								3		
						2500	SW	4		
5' split 8' hole	5.0	2.1	FAIL	1	1	2500		15	Saturated at 15'	material from 12-17' same as above
						2500		6		Sand: gray, medium grained, moist to wet, loose.
								17		13.00 to 17.0'
								8		
								9		
							SC	20		
								1		Sandy clay; brown, moist, median
								2		stiff, to soft, moderately plastic
								3		mottled.
								4		
								25		
								6		T.D. = 25'
								7		
								8		
								9		
								0		
								1		
								2		
								3		
								4		
								5		
								6		
								7		
								0		

NOTES:



FIELD LOG OF BORING

SHEET 1 OF 2

PLAN

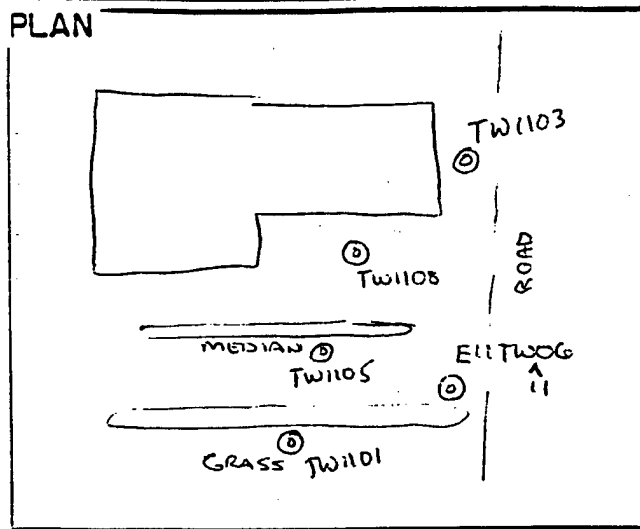

PROJECT <i>EAKEL AFB</i>	BORING NO. <i>E11TW1106</i> <i>5474006 JSG</i>
JOB NO. <i>3K9B</i>	LOGGED BY: <i>BFAI</i>
PROJ. MGR. <i>GVG</i>	EDITED BY:
DRILLING COMPANY: <i>POOL</i>	
DRILL RIG TYPE: <i>mobile, B61</i>	
DRILLING METHOD: <i>Hollow Stem Auger</i>	
DRILLERS NAME: <i>V. Buitrago</i>	
TOTAL DEPTH (FT.) <i>25</i>	
TIME STARTED <i>0936</i>	DATE <i>12/13/91</i>
TIME COMPLETED <i>1020</i>	DATE <i>12:13:91</i>

GROUND-WATER CONDITION AT COMPLETION OF DRILLING
saturated at 16.5' and at 9.0'

BACKFILLED, TIME _____ DATE *SEE COMPLETION FORM*

WEATHER CONDITIONS
Partly cloudy, lite breeze, cool

SURFACE ELEVATION _____

SAMPLER TYPE	FEET DRIVEN	FEET RECOVERED	SAMPLE CONDITION	FIELD LABORATORY SAMPLE NUMBER	FIXED LABORATORY SAMPLE NUMBER	HNU SCAN (PPM)	LITHOLOGIC CODE	DEPTH (FEET)
<i>Carbide S.T.</i>	<i>20</i>	<i>0</i>	<i>1</i>	<i>1</i>	<i>1</i>			<i>1</i>
<i>5' SPLIT BARREL</i>	<i>50</i>	<i>50</i>	<i>Sand</i>	<i>1</i>	<i>1</i>	<i>60</i>	<i>ML</i>	<i>2</i>
<i>5' SPLIT BARREL</i>	<i>50</i>	<i>50</i>	<i>Sand</i>	<i>1</i>	<i>1</i>	<i>50</i>	<i>ML</i>	<i>3</i>
								<i>4</i>
								<i>5</i>
								<i>6</i>
								<i>7</i>
								<i>8</i>
								<i>9</i>
								<i>10</i>

COMMENTS

Asphalt at surface and -0.3'
Fill: Gravel mixed w/ fines

Fill: Silty Clay, dense gray, moist silt, w/ some small concretions 0.3 to 3.5

Silty Clay, gray to brown w/ some sand, moist, medium to stiff w/ some oxide nodules, slightly mottled. 3.5 to 7.0

Sand clay / clayey sand, brown to gray brown, moist to wet in 2005, sand is fine grained 7.0 to 10.0

FIELD LOG OF BORING (CONT'D.)

SHEET 2 OF 2

SAMPLER TYPE	FEET DRIVEN	FEET RECOVERED	SAMPLE CONDITION	FIELD LAB. SAMPLE NO.	FIXED LAB. SAMPLE NO.	HNUSSCAN (PPM)	LITHOLOGIC CODE	DEPTH (FEET)	PROJECT	BORING NO.
									WALKER AFB	E11 TUBE 6
									JOB NO. 3K98	
5' SAMPLE DUPLET	5.0	5.0	5.0	/	/	0	CL	1-4		
								5-6		
5' SAMPLE BYPASS	5.0	4.0	4.0	/	/	0	SW	7-16		
								17-20		
NO SAMPLE BYPASS							CL CH	21-24		
								25-27		
								28-35		
								36-37		
								38-40		
								41-42		
								43-44		
								45-46		
								47-48		
								49-50		

Clay; brown, w/ some sand & silt
moist, medium stiff, moderate
plasticity, slightly mottled
10 - 16.5

material becomes stiffer and
more clayey from 12-16' depth
Sand seam at 16.5' to 17' depth
medium to coarse grained

Sand; gray to brownish gray
moist to wet, soft, non plastic
trace amount of clay
16.5 to 21.0

Sandy clay / clayey sand gray brown
moist, soft to medium stiff
Clay content greatly increases at 22

Transitions back into clay w/
some sand & silt, stiff, plastic
22 to 35'

TD = 55'

NOTES:



FIELD LOG OF BORING

SHEET 1 OF 2

PLAN

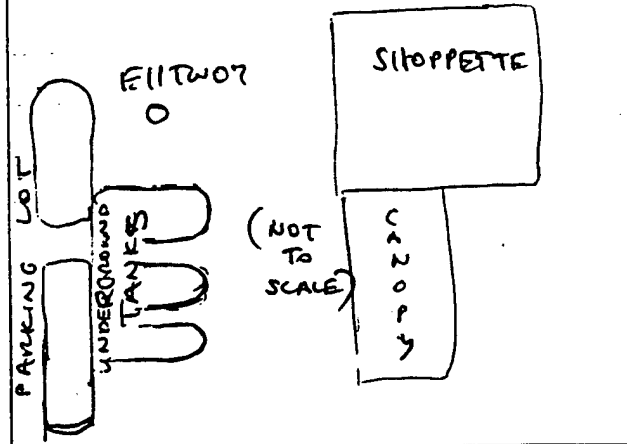

PROJECT EAKER AFB	BORING NO. E11TW07
JOB NO. 3K98	LOGGED BY: URE
PROJ. MGR. GVG	EDITED BY: BFN
DRILLING COMPANY: A.V. POOL	
DRILL RIG TYPE: B-61	
DRILLING METHOD: HOLLOW STEM AUGER	
DRILLERS NAME: VINCE BARRAZZO	
TOTAL DEPTH (FT.) 30'	
TIME STARTED 1515	DATE 12/13/91
TIME COMPLETED 1600	DATE 12/13/91

GROUND-WATER CONDITION AT COMPLETION OF DRILLING
barrel saturated at ±22'

BACKFILLED, TIME: **—** DATE: **—**

WEATHER CONDITIONS
Partly cloudy, 5 mph wind, 55°F

SURFACE ELEVATION

SAMPLER TYPE	FEET DRIVEN	FEET RECOVERED	SAMPLE CONDITION	FIELD LABORATORY SAMPLE NUMBER	FIXED LABORATORY SAMPLE NUMBER	HNU SCAN (PPM)	LITHOLOGIC CODE	DEPTH (FEET)
BIT	20	1	-	-	-	-	-	1
SPLIT BARREL	5.0	3.5	EXCELLENT	E11TW07-1	-	7500	SW/SC	2-4
SPLIT BARREL	5.0	5.0	EXCELLENT	-	-	7500	SC	5-10

COMMENTS

ASPHALT @ SURFACE
0-3.5' Asphalt + Fill

3.5-6.5'; CLAYEY SAND + SANDY CLAY, ALTERNATING, SAND - MEDIUM TO COARSE GRAINED; CLAY - MODERATELY SOFT, DARK BROWN. MOIST

6.5-10.5; CLAYEY SAND, grey, fine-grained; moist to wet.

FIELD LOG OF BORING (CONT'D.)

SHEET 2 OF 2

SAMPLER TYPE	FEET DRIVEN	FEET RECOVERED	SAMPLE CONDITION	FIELD LAB. SAMPLE NO.	FIXED LAB. SAMPLE NO.	HNUSCAN (PPM)	LITHOLOGIC CODE	DEPTH (FEET)	PROJECT	BORING NO.
									EAKER AFB	E11TW1107
								JOB NO. 3K98	E11TW07 JK	
								11	10.5 - 21.0; BROWN-GREY CLAY, hard, plastic, mottled	
								12		
								13		
								14		
								15		
								16		
								17		
								18		
								19		
								20		
								21	21.0 - 22.0; SANDY CLAY, soft, brown, saturated.	
								22		
								23		
								24		
								25		
								26		
								27	BETWEEN 22-30 - MED. TO COARSE SAND	
								28	ALTERNATING W/ MOD. HARD, DARK GREY CLAY, MOSTLY CLAY HORIZONS.	
								29		
								30		
								1		
								2		
								3		
								4		
								5		
								6		
								7		
								8		
								9		
								0		

NOTES:



FIELD LOG OF BORING

SHEET 1 OF 2

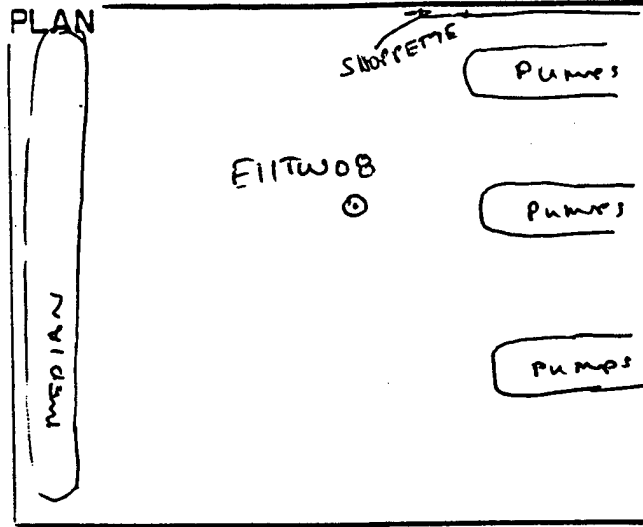

PROJECT EAKER AFB	BORING NO. E11TW1108 E11TW08 #M
JOB NO. 3K98	LOGGED BY: LRF
PROJ. MGR. GVG	EDITED BY: BEN
DRILLING COMPANY: A.W. POOL	
DRILL RIG TYPE: B-81 6'	
DRILLING METHOD: Hollow Stem Augers	
DRILLERS NAME: VINCE BARRAZZO	
TOTAL DEPTH (FT.) 29	
TIME STARTED 0745 0845 AM	DATE 12/14/91
TIME COMPLETED 0825	DATE 12/14/91

SAMPLER TYPE	FEET DRIVEN	FEET RECOVERED	SAMPLE CONDITION	FIELD LABORATORY SAMPLE NUMBER	FIXED LABORATORY SAMPLE NUMBER	HNU SCAN (PPM)	LITHOLOGIC CODE	DEPTH (FEET)
BIT	2.0	-	-	-	-	-		1
SPUT BARREL	5.0	2.5	Good	-	E11-su-sd1108A	7500	SW	2-5
SPUT BARREL	5.0	5.0	EXCELLENT	-	-	7500	SC	6-10

GROUND-WATER CONDITION AT COMPLETION OF DRILLING
Saturated zones at 10' and 21'

BACKFILLED, TIME 219.00	DATE 12-18-91
-------------------------	---------------

WEATHER CONDITIONS
PARTLY CLOUDY, HIGH 40S, 10MPH WIND

SURFACE ELEVATION

COMMENTS

ASPHALT @ SURFACE

FILL 0'-6.5', SAND, WELL SORTED. MED. TO COARSE GRAINED

6.5' - 10' SANDY CLAY, BROWN W. GRAY-MOTTLES, MOIST, HYDRO CARBON ODOR. BECOMES SANDIER W/ DEPTH

FIELD LOG OF BORING (CONT'D.)

SHEET 2 OF 2

SAMPLER TYPE	FEET DRIVEN	FEET RECOVERED	SAMPLE CONDITION	FIELD LAB. SAMPLE NO.	FIXED LAB. SAMPLE NO.	HNUSCAN (PPM)	LITHOLOGIC CODE	DEPTH (FEET)	PROJECT	BORING NO.
									EAKER	TW
									JOB NO. 3K98	EH 808 E11TW110
						150	SW	11		10'-11' SAND; MEDIUM GRAINED, WET, APPEARS TO CONTAIN FREE PRODUCT
						5000		12		
						150	CL	13		11'-21' CLAY, brown w/ grey mottles, hard, plastic
						50	CL	14		
						0		15		
						50		16		
						0		17		
						50		18		
						0		19		
						0	CL	20		21-TO CLAY, grey, hard, moderately plastic
						0		21		WET @ 21.
						0		22		SOME SAND ZONES PROBABLE BASED ON DRILLER'S COMMENTS.
						0		23		
						0		24		
						0		25		
						0		26		
						0		27		
						0		28		
						0		29		
						0		0		
						0		1		
						0		2		
						0		3		
						0		4		
						0		5		
						0		6		
						0		7		
						0		8		
						0		9		
						0		10		

NOTES:





FIELD LOG OF BORING

SHEET 1 OF 2

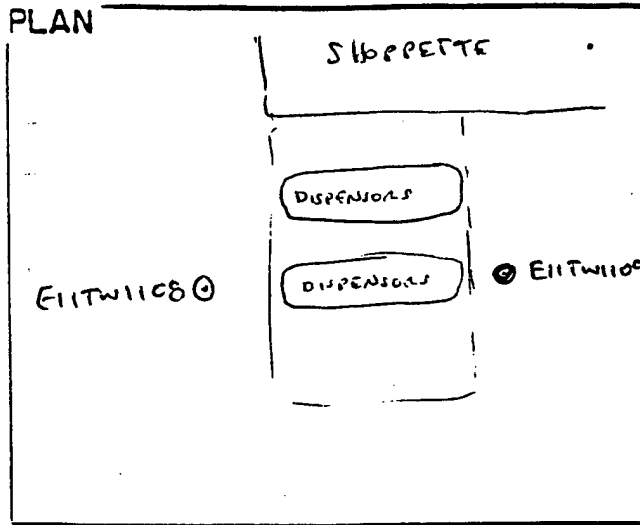

PROJECT	BORING NO.
EAKER AFB	E11TW1109
JOB NO. 3K98	LOGGED BY: URE
PROJ. MGR. GUG	EDITED BY: BFM
DRILLING COMPANY: A.W POOL	
DRILL RIG TYPE: B-2 61	
DRILLING METHOD: Hollow stem Auger	
DRILLERS NAME: V. BARRAZZO	
TOTAL DEPTH (FT.) 25	
TIME STARTED 0925	DATE 12/14/91
TIME COMPLETED 0955	DATE 12/14/91

GROUND-WATER CONDITION AT COMPLETION OF DRILLING
saturated at ± 10 and ± 21.5

BACKFILLED, TIME _____ DATE _____

WEATHER CONDITIONS
CLEAR, UPPER 30s, 10 MPH WIND

SURFACE ELEVATION _____

SAMPLER TYPE	FEET DRIVEN	FEET RECOVERED	SAMPLE CONDITION	FIELD LABORATORY SAMPLE NUMBER	FIXED LABORATORY SAMPLE NUMBER	HNU SCAN (PPM)	LITHOLOGIC CODE	DEPTH (FEET)
BIT	2.0	-	-	-	-	-	FM	1
S.B.	5.0	3.5	Good	-	E11-Su-Tw1109A	2000	SV	2
S.B.	5.0	4.0	Good	-	E11-Su-Tw1109B	2500	CL/CH	3
S.B.	5.0	4.0	Good	-	E11-Su-Tw1109C	2500	SW	4
S.B.	5.0	4.0	Good	-	E11-Su-Tw1109D	2500	SW	5
S.B.	5.0	4.0	Good	-	E11-Su-Tw1109E	2500	SW	6
S.B.	5.0	4.0	Good	-	E11-Su-Tw1109F	2500	SW	7
S.B.	5.0	4.0	Good	-	E11-Su-Tw1109G	2500	SW	8
S.B.	5.0	4.0	Good	-	E11-Su-Tw1109H	2500	SW	9
S.B.	5.0	4.0	Good	-	E11-Su-Tw1109I	2500	SW	10

COMMENTS

ASPHALT @ SURFACE

0-4.5' Fill, mostly medium grained sand, well sorted

4.5-6.0' Clay, dark brownish grey, moderately soft, slightly plastic transition into lower brown clay

6.0-9.5' SANDY CLAY, REDDISH BROWN, GREY MOTTLES, SOME SILT.

9.5-10.5' SAND, FINE GRAINED, GREY, WET, FREE PRODUCT APPEARS TO BE PRESENT.

FIELD LOG OF BORING (CONT'D.)

SHEET 2 OF 2

SAMPLER TYPE	FEET DRIVEN	FEET RECOVERED	SAMPLE CONDITION	FIELD LAB. SAMPLE NO.	FIXED LAB. SAMPLE NO.	HNUSCAN (PPM)	LITHOLOGIC CODE	DEPTH (FEET)	PROJECT	BORING NO.
									EAKER	E11TW1109
									JOB NO. 3K98	
						500		11		10.5-15, CLAY, MOTTLED RED + GREY,
								12		MODERATELY PLASTIC, ABUNDANT Fe ₂ O ₃
						18	CL	13		CONCRETIONS, MINOR SILT, MOIST.
							CH	14		-TRANSITION INTO LOWER UNIT
S.B.	5.0	5.0	EXCELLENT	-	-	30		15		15-19.5 CLAY, GREY, MODERATELY
						10		16		PLASTIC, MINOR SILT; DAMP ^{SLT}
								17		Slightly moist
						0		18		
S.B.	5.0	5.0	EXCELLENT	-	E11-SU-TW1109C	0		19		
						0		20		19.5-25.? SILTY CLAY, GREY W/SOME
						0		21		LT. BRN ^{reddish} LAMINAE, SOFT. WATER
								22		NOTED @ ~ 21.5'
								23		
BIT	-	-	-	-	-	-		24		TD = 25'
								25		
								26		
								27		
								28		
								29		
								30		

NOTES:



FIELD LOG OF BORING

SHEET 1 OF 2

PLAN	STOPPETTE	
	DISPENSERS	⊙ E11TW10
	CANONS	
	DISPENSERS	⊙ E11TW09
	VACUUMS	
	PROJECT	EAKER AFB
	BORING NO.	E11TW110 JSS 2/31/92
	JOB NO.	3K90
	PROJ. MGR.	GUC
	LOGGED BY:	URE
EDITED BY:	BFN	
DRILLING COMPANY:	A.W POOL	
DRILL RIG TYPE:	B-61	
DRILLING METHOD:	HOLLOW STEM AUGER	
DRILLERS NAME:	V. BARRAZZA	
TOTAL DEPTH (FT.)	25	
TIME STARTED	1322	
DATE	12/14/91	
TIME COMPLETED	1355	
DATE	12/14/91	

SAMPLER TYPE	FEET DRIVEN	FEET RECOVERED	SAMPLE CONDITION	FIELD LABORATORY SAMPLE NUMBER	FIXED LABORATORY SAMPLE NUMBER	HNU SCAN (PPM)	LITHOLOGIC CODE	DEPTH (FEET)
Bit	2.0	-	-	-	-	-	-	1
S.B.	5.0	4.5	Good	-	E11-Su-Tw1110A @ 7'	100	SC	2
S.B.	5.0	3.5	-	-	E11-Su-Tw1110B @ 8.5'	300	SC	3
								4
								5
								6
								7
								8
								9
								10

GROUND-WATER CONDITION AT COMPLETION OF DRILLING
SATURATED 18.5'

BACKFILLED, TIME _____ DATE _____

WEATHER CONDITIONS
CLEAR, MID 40S, 10 MPH WIND

SURFACE ELEVATION _____

COMMENTS
ASPHALT @ SURFACE
0-2.5' Fill (NOT RECOVERED)
2.5' - 4.5' SANDY CLAY, DARK BROWN, ORGANIC RICH
- TRANSITION w/ LOWER UNIT
4.5' - 8.5' SANDY CLAY TO CLAYEY SAND, BROWN w/ GREY MOTTLES, MOD. SOFT, DAMP.
8.5' - 9.5' CLAYEY SAND, BROWN w/ GREY MOTTLES, MOD. TO FINE GRAINED

FIELD LOG OF BORING (CONT'D.)

SHEET 2 OF 2

SAMPLER TYPE	FEET DRIVEN	FEET RECOVERED	SAMPLE CONDITION	FIELD LAB. SAMPLE NO.	FIXED LAB. SAMPLE NO.	HNUSCAN (PPM)	LITHOLOGIC CODE	DEPTH (FEET)	PROJECT	BORING NO.
									EAKER AFB	E11 TW1110
									JOB NO. 3K98	
								11	8.5'-9.5' (CONTINUED) WET IN SAND ZONE.	
								12	9.5'-13' CLAY, HARD, PLASTIC, BROWN	
						0	CL	13	w/ GREY MOTTLES, MINOR SILT, Fe STAINS	
						0	CH	14	and nodules. DAMP.	
S.B	5.0	5.0	EXCELLENT			0		15	-TRANSITION ZONE w/ GREY CLAY BELOW	
						0		16	13'-22' CLAY, GREY, HARD PLASTIC,	
						0		17	SOME RED STAINS, MINOR SILT	
						0		18		
S.B	5.0	5.0	EXCELLENT			0		19	22'-25' BIT (NO RECOVERY)	
						0		20		
						0		21		
BIT	-	-	-	-	-	-		22		
								23		
								24		
								25		
								6	TO ^{25'} 22' 24'	
								7		
								8		
								9		
								0		
								1		
								2		
								3		
								4		
								5		
								6		
								7		
								8		
								9		
								0		

NOTES:



FIELD LOG OF BORING

SHEET 1 OF 2

PLAN

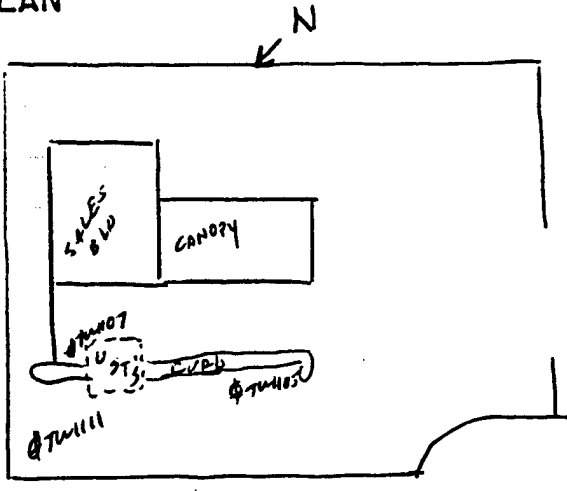

PROJECT EAKER AFB	BORING NO. E11TW111
JOB NO. 3K98	LOGGED BY: BFN
PROJ. MGR. GVG	EDITED BY: BFN-BEN
DRILLING COMPANY: Pool	
DRILL RIG TYPE: mobile, B61	
DRILLING METHOD: 6 1/4" Hollow stem Augers	
DRILLERS NAME: V. Burrazza	
TOTAL DEPTH (FT.) 22'	
TIME STARTED 0753	DATE 12-15-91
TIME COMPLETED 0818	DATE 12-15-91

GROUND-WATER CONDITION AT COMPLETION OF DRILLING
saturated at ≈ 110 and at $\approx 21'$

BACKFILLED, TIME	DATE
WEATHER CONDITIONS clear, cold, light breeze $\approx 30^\circ F$	
SURFACE ELEVATION	

SAMPLER TYPE	FEET DRIVEN	FEET RECOVERED	SAMPLE CONDITION	FIELD LABORATORY SAMPLE NUMBER	FIXED LABORATORY SAMPLE NUMBER	HNU SCAN (PPM)	LITHOLOGIC CODE	DEPTH (FEET)
5' SPLIT BARREL	2	0	—	—	—	—	SW	1
5' SPLIT BARREL	5'	2'	POOR	E11TW111-1	1	75000	CL	2-7
5' SPLIT BARREL	5'	5'	—	E11TW111-2	—	75000	CL	8-10

COMMENTS

Asphalt at surface 0.0-0.3

Fill; gravel mixed w/ fines 0.3-1.0'

Fill: Sand, heavy to very heavy medium to coarse grained, loose 1.0 to 7.0

Clay, brown, with silt and trace of sand moist, soft to medium stiff, 7.0-10.0'

saturated zone $\approx 110'$

Sandy zone w/ clay matrix moist to wet, soft 10 to 11.0'

FIELD LOG OF BORING (CONT'D.)

SHEET 2 OF 2

SAMPLER TYPE	FEET DRIVEN	FEET RECOVERED	SAMPLE CONDITION	FIELD LAB. SAMPLE NO.	FIXED LAB. SAMPLE NO.	HNUSCAN (PPM)	LITHOLOGIC CODE	DEPTH (FEET)	PROJECT	BORING NO.
									EAKEL AFB	
								JOB NO. 3K98	E1124111	
5' split barrel	5'	5'	Good	1	1	600	CL	1		
						600		2	Silty clay, brown, w/ some sand	
						600		3	no mottled zones, very moist, medium	
								4	stiff 11.0 - 16	
								5		
								6		
								7	Clay, blue gray, moist, very stiff	
								8	plastic, some silt present, mottled	
								9	16 - 22'	
5' split barrel	5'	5'	Good	1	1	0	CL/CH	20		
						0		1	Saturated zone at ~ 21'	
						0		2		
								3		
								4		
								5		
								6		
								7		
								8		
								9		
								0		

NOTES:



FIELD LOG OF BORING

SHEET 1 OF 2

PLAN

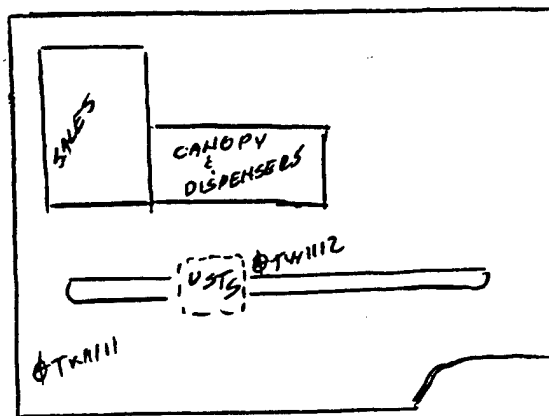

PROJECT <i>EAKER AFB</i>	BORING NO. <i>E11TW1112</i>
JOB NO. <i>3K98</i>	LOGGED BY: <i>BFN</i>
PROJ. MGR. <i>GVG</i>	EDITED BY: <i>JSB</i>
DRILLING COMPANY: <i>Pool</i>	
DRILL RIG TYPE: <i>MOBILE B61</i>	
DRILLING METHOD: <i>6" Hollow Stem Auger</i>	
DRILLERS NAME: <i>V. Barazzza</i>	
TOTAL DEPTH (FT.) <i>25</i>	
TIME STARTED <i>0915</i>	DATE <i>12-15-91</i>
TIME COMPLETED <i>1030</i>	DATE <i>12-15-91</i>

GROUND-WATER CONDITION AT COMPLETION OF DRILLING
Saturated zones @ 8.5', 10.5' and 121'

BACKFILLED, TIME *13:40* DATE *12-18-91*

WEATHER CONDITIONS
clear, cold, light breeze ~30°F

SAMPLER TYPE	FEET DRIVEN	FEET RECOVERED	SAMPLE CONDITION	FIELD LABORATORY SAMPLE NUMBER	FIXED LABORATORY SAMPLE NUMBER	HNU SCAN (PPM)	LITHOLOGIC CODE	DEPTH (FEET)
<i>5' SPLIT BARREL</i>	<i>2</i>	<i>0</i>	<i>1</i>	<i>1</i>	<i>1</i>	<i>75000</i>		<i>1</i>
<i>5' SPLIT BARREL</i>	<i>5'</i>	<i>4'</i>	<i>5000'</i>	<i>1</i>	<i>1</i>	<i>75000</i>	<i>S/C</i>	<i>2</i>
<i>5' SPLIT BARREL</i>	<i>5'</i>	<i>5000'</i>	<i>1</i>	<i>1</i>	<i>75000</i>	<i>SW</i>	<i>50</i>	<i>3</i>
<i>5' SPLIT BARREL</i>	<i>5'</i>	<i>5000'</i>	<i>1</i>	<i>1</i>	<i>75000</i>	<i>SW</i>	<i>50</i>	<i>4</i>
<i>5' SPLIT BARREL</i>	<i>5'</i>	<i>5000'</i>	<i>1</i>	<i>1</i>	<i>75000</i>	<i>SW</i>	<i>50</i>	<i>5</i>
<i>5' SPLIT BARREL</i>	<i>5'</i>	<i>5000'</i>	<i>1</i>	<i>1</i>	<i>75000</i>	<i>SW</i>	<i>50</i>	<i>6</i>
<i>5' SPLIT BARREL</i>	<i>5'</i>	<i>5000'</i>	<i>1</i>	<i>1</i>	<i>75000</i>	<i>SW</i>	<i>50</i>	<i>7</i>
<i>5' SPLIT BARREL</i>	<i>5'</i>	<i>5000'</i>	<i>1</i>	<i>1</i>	<i>75000</i>	<i>SW</i>	<i>50</i>	<i>8</i>
<i>5' SPLIT BARREL</i>	<i>5'</i>	<i>5000'</i>	<i>1</i>	<i>1</i>	<i>75000</i>	<i>SW</i>	<i>50</i>	<i>9</i>
<i>5' SPLIT BARREL</i>	<i>5'</i>	<i>5000'</i>	<i>1</i>	<i>1</i>	<i>75000</i>	<i>SW</i>	<i>50</i>	<i>10</i>

SURFACE ELEVATION

COMMENTS

Asphalt at surface 0.0-0.3

Fill: Gravel clast mixed w/ fines 0.3-1.0

Sandy clay, gray w/ some silt moist, soft, trace organics (root traces) possible fill strong hydrocarbon odor.

Sand seam @ 8' to 8.5', saturated

Sand seam @ 10' to 10.5' saturated

Clay content begins to increase below 10.5'

FIELD LOG OF BORING (CONT'D.)

SHEET 2 OF 2

SAMPLER TYPE	FEET DRIVEN	FEET RECOVERED	SAMPLE CONDITION	FIELD LAB. SAMPLE NO.	FIXED LAB. SAMPLE NO.	HNUSCAN (PPM)	LITHOLOGIC CODE	DEPTH (FEET)	PROJECT	BORING NO.
									EAKEL AFB	
								JOB NO. 3K98	E11TW1112	
5' SPLIT BARREL	5	5	good	/	/	2500	CL CH	11		
								12		
								13	Clay, brownish gray, slightly mottled, moist medium stiff	
								14	some silt, trace of sand, plastic	
								15	10.5 - 15.0	
								16		
								17		
5' SPLIT BARREL	5	5	good	/	/	0	CL CH	18	stiffness increases with depth	
								19		
								20		
								21	Clay, blue gray, moist, stiff plastic	
								22	saturated zone at ± 21'	
								23	15 - 25'	
								24		
								25		
								6	TD = 25'	
								7		
								8		
								9		
								0		
								1		
								2		
								3		
								4		
								5		
								6		
								7		
								8		
								9		
								0		

NOTES:

FIELD LOG OF BORING

SHEET 1 OF 2

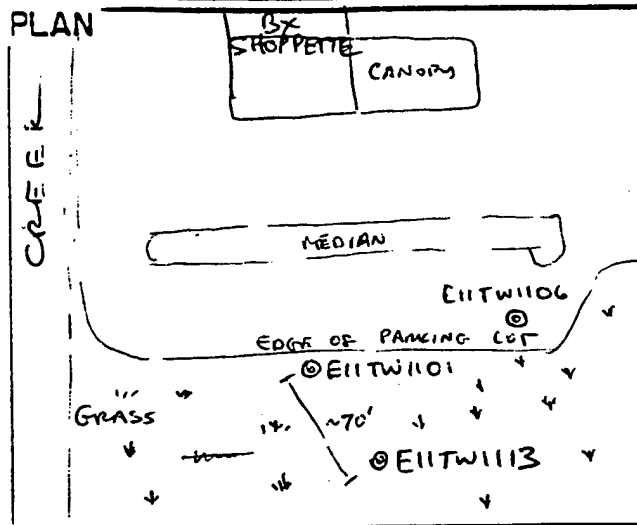

PROJECT	BORING NO.
FAKEL AFB	E11TW1113
JOB NO. 3198	LOGGED BY: LRE
PROJ. MGR. GUG	EDITED BY: BFN
DRILLING COMPANY: AW POOL	
DRILL RIG TYPE: B-61	
DRILLING METHOD: Hollow Stem Auger	
DRILLERS NAME: V. BARLAZZA	
TOTAL DEPTH (FT.) 27	
TIME STARTED 1350	DATE 12/15/91
TIME COMPLETED 1445	DATE 12/15/91

SAMPLER TYPE	FEET DRIVEN	FEET RECOVERED	SAMPLE CONDITION	FIELD LABORATORY SAMPLE NUMBER	FIXED LABORATORY SAMPLE NUMBER	HNU SCAN (PPM)	LITHOLOGIC CODE	DEPTH (FEET)
BIT	2.0	-	-	-	-	-	ML	1
SPUT BARREL	5.0	5.0	Good	-	-	0	CL	2-4
SPUT BARREL	5.0	5.0	Good	-	-	0	CL/ML	4-10

GROUND-WATER CONDITION AT COMPLETION OF DRILLING
saturated zones at 5' and 22'

BACKFILLED, TIME 0739 DATE 12-18-91

WEATHER CONDITIONS
CLEAR, SML WIND, MID 40S

SURFACE ELEVATION

COMMENTS
GRASS @ SURFACE
0'-3' PLOW ZONE & POSSIBLY FILL.
2'-3' MED. TO COARSE GRAINED SAND, DAMP, SOME BLACK ORGANIC AND RED IRON CONCRETIONS
3'-4.5' SILTY CLAY, DARK BROWN, VERY MOIST, SOFT, MOD. PLASTIC
4.5-10' SILTY SANDY CLAY, LT BROWN W/ RED + GREY MOTTLES, BECOMES LIGHTER IN COLOR W/ DEPTH, MORE GREY W/ DEPTH.
ZONES HAVE WATER IN 8'-10' INTERVALS.
SANDY INTERVALS ARE 1"-6" THICK.

FIELD LOG OF BORING (CONT'D.)

SHEET 2 OF 2

SAMPLER TYPE	FEET DRIVEN	FEET RECOVERED	SAMPLE CONDITION	FIELD LAB. SAMPLE NO.	FIXED LAB. SAMPLE NO.	HNUSCAN (PPM)	LITHOLOGIC CODE	DEPTH (FEET)	PROJECT	BORING NO.
									EAGLE AFB	E11TW113
									JOB NO. 3K98	
	PREVIOUS		PAGE			0		11		10'-21' CLAY, LT BROWN TO GREY,
								12		SILTY; RED IRON STAINS 12'-21'
								13		- BECOMES GREYER & LESS SILTY
								14		IN 12'-19.5' INTERVAL, PLASTIC,
S.B.	5.0	5.0	EXCELLENT	-	-	0	CL CH	15		HARD
						0		16		
								17		- 19.5 - 21', BECOMES LT BROWNISH
								18		RED, LESS PLASTIC, MORE SILTY
								19		TIMING ABOVE
S.B.	5.0	5.0	EXCELLENT	E1113-01 @ 22'	-	2		20		
						7		21		21'-27' SAND, COARSE GRAINED, MOD.
								22		WELL SORTED, WET.
								23		
								24		22'-27' IS SAND (AS PER DRILLER'S COMMENTS)
								25		
								26		TD = 27'
								27		
								8		
								9		
								0		
								1		
								2		
								3		
								4		
								5		
								6		
								7		
								8		
								9		
								0		

NOTES:



FIELD LOG OF BORING

SHEET 1 OF 2

PLAN

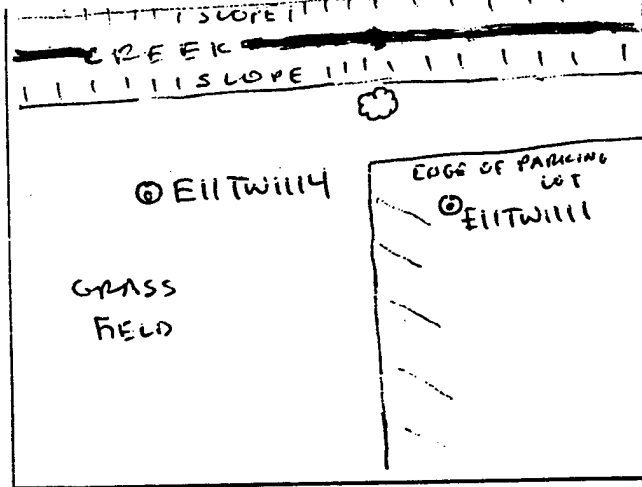

PROJECT EAKET AFB	BORING NO. E11 TW1114
JOB NO. 3K9E	LOGGED BY: LRE
PROJ. MGR. GVG	EDITED BY: BFH
DRILLING COMPANY: A.W POOL	
DRILL RIG TYPE: B-61	
DRILLING METHOD: Hollow STEM AUGER	
DRILLERS NAME: V. BARRAZA	
TOTAL DEPTH (FT.) 24'	

TIME STARTED 0955	DATE 12/16/91
TIME COMPLETED 1105	DATE 12/16/91
GROUND-WATER CONDITION AT COMPLETION OF DRILLING <i>saturated zone at ±8 and ±21'</i>	

BACKFILLED, TIME	DATE
WEATHER CONDITIONS CLEAR, MID 30s, 5 mph WIND	

SURFACE ELEVATION

COMMENTS

SAMPLER TYPE	FEET DRIVEN	FEET RECOVERED	SAMPLE CONDITION	FIELD LABORATORY SAMPLE NUMBER	FIXED LABORATORY SAMPLE NUMBER	HNU SCAN (PPM)	LITHOLOGIC CODE	DEPTH (FEET)
BIT	2.0	-	-	-	-	-		1
								2
								3
								4
S.B.	5.0	3.0	GOOD	1	1	0	SW	5
								6
							CL CH	7
								8
								9
S.B.	5.0	4.5	EXCELLENT	1	1	0	CL Clt	10

GRASS @ SURFACE

0-4' NO RECOVERY

4.8-5.0 SAND, MED GRAINED, MOIST.

5'-6' Silty CLAY, DARK BROWN, MOD. SOFT, SLIGHTLY PLASTIC, MOIST.

MINOR SAND

6'-13' SANDY, SILTY CLAY, BROWN MORE CLAYEY ZONES w/ GRAY MOTTLES. SLIGHTLY PLASTIC, HIGH IRON STAINS

12'-13' WET ZONE 8'-10' IN MORE SANDY ZONES INTERVALS

FIELD LOG OF BORING (CONT'D.)

SAMPLER TYPE	FEET DRIVEN	FEET RECOVERED	SAMPLE CONDITION	FIELD LAB. SAMPLE NO.	FIXED LAB. SAMPLE NO.	HNUSCAN (PPM)	LITHOLOGIC CODE	DEPTH (FEET)	PROJECT	BORING NO.
									EAKER AFB	E11 TW1114
									JOB NO. 3K98	
S.B.	SEE PREV		PAGE			0		11		
						0		12		
						0		13	-TRANSITION W/ LOWER GREY UNIT @ 13'	
						0		14	13'-21' CLAY, GREY, HARD, PLASTIC,	
						0		15	RED IRON STAINS 13'-16'.	
S.B.	5.0	5.0	EXCELLENT	-	-	0	CL	16	-BECOMES HARDER + MORE PLASTIC	
						0	CH	17	W/ DEPTH.	
						0		18		
						0		19		
S.B.	5.0		EXCELLENT	E1114-1	-	0		20		
						0		21		
						0	SW	22	21'-24'* SAND, COARSE GRAINED; WET;	
						0		23	MOD. WELL SORTED	
BIT	2.0	-	-	-	-	-		24	WET @ ~21'	
								25		
								26	TD=24	
								27		
								28		
								29		
								30		
								31		
								32		
								33		
								34		
								35		
								36		
								37		
								38		
								39		
								40		

NOTES: * As per driller's comments



FIELD LOG OF BORING

SHEET 1 OF 2

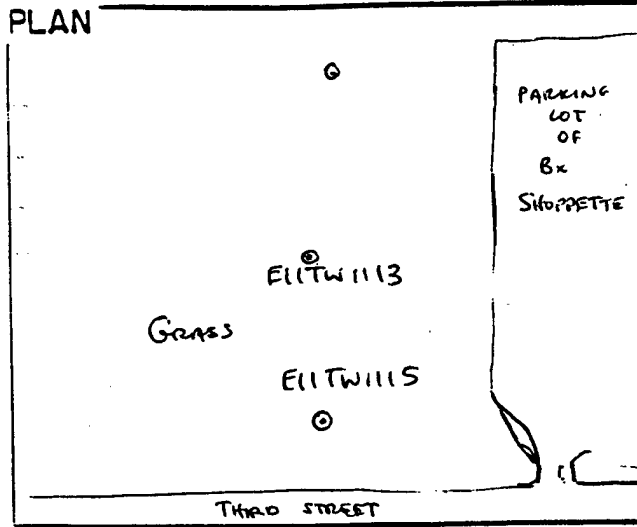

PROJECT	BORING NO.
EAKER AFB	E11TW1115
JOB NO. 31498	LOGGED BY: JLL
PROJ. MGR. GVG	EDITED BY: BFN
DRILLING COMPANY: A.W. POOL	
DRILL RIG TYPE: B-61	
DRILLING METHOD: Hollow Stem Auger	
DRILLERS NAME: V. BARRAZA	
TOTAL DEPTH (FT.) 22'	
TIME STARTED 1320	DATE 12/16/91
TIME COMPLETED 1420	DATE 12/16/91

GROUND-WATER CONDITION AT COMPLETION OF DRILLING
 Saturated zones at ± 7' and 17'

BACKFILLED, TIME	DATE

WEATHER CONDITIONS
 CLEAR, MID TO UPPER 40s, LIGHT WIND

SURFACE ELEVATION

COMMENTS

SAMPLER TYPE	FEET DRIVEN	FEET RECOVERED	SAMPLE CONDITION	FIELD LABORATORY SAMPLE NUMBER	FIXED LABORATORY SAMPLE NUMBER	HNU SCAN (PPM)	LITHOLOGIC CODE	DEPTH (FEET)
BIT	2.0	-	-	-	-	-	CL	1
S.B	5.0	5.0	EXCELLENT			0	ML CL	2-9
S.B	5.0	5.0	EXCELLENT	E115-1 e8		0	CL CH	9-19

GRASS @ SURFACE

0-2 NO RECOVERY

2'-3' CLAY, DARK BROWN, ORGANIC RICH, ABUNDANT ROOT HAIRS. MOIST

3'-9' CLAYEY, SANDY, SILT/SILTY SANDY CLAY; BROWN. SILTY ZONES ARE MORE FRABLE THAN CLAYEY ZONES. ROOT HAIRS + ORGANICS @ DP. MOIST

- WET ZONE ~ 7' WHERE MORE SAND IS PRESENT

9'-19' CLAY, BROWNISH GREY w/ RED MOTTLES, HARD, PLASTIC. MINOR SD + SILT.

FIELD LOG OF BORING (CONT'D.)

SHEET 2 OF 2

SAMPLER TYPE	FEET DRIVEN	FEET RECOVERED	SAMPLE CONDITION	FIELD LAB. SAMPLE NO.	FIXED LAB. SAMPLE NO.	HNUSCAN (PPM)	LITHOLOGIC CODE	DEPTH (FEET)	PROJECT	BORING NO.
									EAKER AFB	E11TW1115
									JOB NO. 3K98	
								11		MOIST 9-
								12		- IRON STAINS 11'-12'
								13		
S.B.	5.0	5.0	Excellent			0		14		
						0		15		
						0		16		
						0		17		
						0		18		
S.B.	6.0	5.0	Excellent	19'-20'		0	SC	19		19-20 CLAYEY SAND, LAMINATED. SAND FINE GRAINED
				E1115-2		0		20		- SAMPLE SATURATED @ 19.5'. VERY
						2		21		MOIST TO WET UP TO 17'. GREYISH BROWN
								22		w/ REDDISH ^{sil} LAMINAE
								3		
								4		TD = 22'
								5		
								6		
								7		
								8		
								9		
								0		

NOTES:





FIELD LOG OF BORING

SHEET 1 OF 2

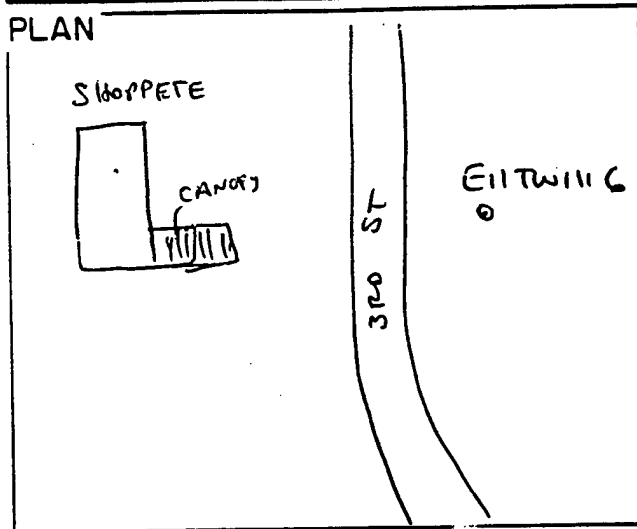

PROJECT EAKER AFB	BORING NO. E11TW1116
JOB NO. 3K98	LOGGED BY: JLK
PROJ. MGR. GJG	EDITED BY: BFN
DRILLING COMPANY: A.W. POOL	
DRILL RIG TYPE: B-61	
DRILLING METHOD: HOLLOW STEM AUGER	
DRILLERS NAME: V. BARRAZA	
TOTAL DEPTH (FT.) 22'	

TIME STARTED 1530	DATE 12/16/91
TIME COMPLETED 1425 <small>1600 REN</small>	DATE 12/16/91
GROUND-WATER CONDITION AT COMPLETION OF DRILLING SATURATED 2012 ± 10 and 47, 15'	

BACKFILLED, TIME -	DATE -
WEATHER CONDITIONS CLEAR, MID 50s, LIGHT WIND	

SAMPLER TYPE	FEET DRIVEN	FEET RECOVERED	SAMPLE CONDITION	FIELD LABORATORY SAMPLE NUMBER	FIXED LABORATORY SAMPLE NUMBER	HNU SCAN (PPM)	LITHOLOGIC CODE	DEPTH (FEET)
BIT	2.0	1	-	-	-	-		1
SB	5.0	4.5	Good	-	-	0	CL	2-3
SB	5.0	4.0	Good	E1116-1 10'	12'	0	ML	6-7
SB	5.0	4.0	Good	E1116-1 10'	12'	0		8-9

SURFACE ELEVATION	
COMMENTS	GRASS @ SURFACE
	0-2.5' NO RECOVERY
	2.5-6 Silty CLAY, ^{Dark} BROWN w/ RED MOTTLES
	- MOIST hard
	6-10.5' CLAYEY SANDY SILT, BROWN w/ REDDISH MOTTLES, VERY MOIST.
	- WET IN ZONES w/ LESS CLAY. ^{REDDISH} LAMINAE.
	SATURATED IN CORE BARREL @ ~8' IN 6" ZONE THAT LESS CLAYEY.

FIELD LOG OF BORING (CONT'D.)

SHEET 2 OF 2

SAMPLER TYPE	FEET DRIVEN	FEET RECOVERED	SAMPLE CONDITION	FIELD LAB. SAMPLE NO.	FIXED LAB. SAMPLE NO.	HNUSCAN (PPM)	LITHOLOGIC CODE	DEPTH (FEET)	PROJECT	BORING NO.
									FAKER AFB	E11TW1116
									JOB NO. 3K98	
								11		
							CL	12		10.5-12.5, Silty clay, ^{BROWNISH} GREY w/ REDDISH MOTTLES, MODERATELY HARD, PLASTIC, VERY MOIST.
S.B.	5.0	5.0	Good	/	/	0	CL	13		
							CL	14		12.5-20, CLAY, ^{BLUE} GREY, MOD. SOFT, MOIST, PLASTIC. SOME SILTY ZONES.
							CH	15		
								16		- REDDISH HEMATITE/LIMONITE @ 14'-16'
								17		
								18		
S.B.	5.0	5.0	Good	E1116-02 @ 18'	-	0		19		- 17-19' WET, MORE SILTY THAN DRIER ZONES ABOVE + BELOW. ^{WETTER}
								20		
								21		- SMALL HEMATITE STAINS 18.5'-20'.
								22		
								23		
								24		
								25		
								26		
								27		
								28		
								29		
								30		
								31		
								32		
								33		
								34		
								35		
								36		
								37		
								38		
								39		
								40		
								41		
								42		
								43		
								44		
								45		
								46		
								47		
								48		
								49		
								50		
								51		
								52		
								53		
								54		
								55		
								56		
								57		
								58		
								59		
								60		
								61		
								62		
								63		
								64		
								65		
								66		
								67		
								68		
								69		
								70		
								71		
								72		
								73		
								74		
								75		
								76		
								77		
								78		
								79		
								80		
								81		
								82		
								83		
								84		
								85		
								86		
								87		
								88		
								89		
								90		
								91		
								92		
								93		
								94		
								95		
								96		
								97		
								98		
								99		
								100		

NOTES:

* WATER ON CONC BARREL @ 21'



FIELD LOG OF BORING

SHEET 1 OF 2

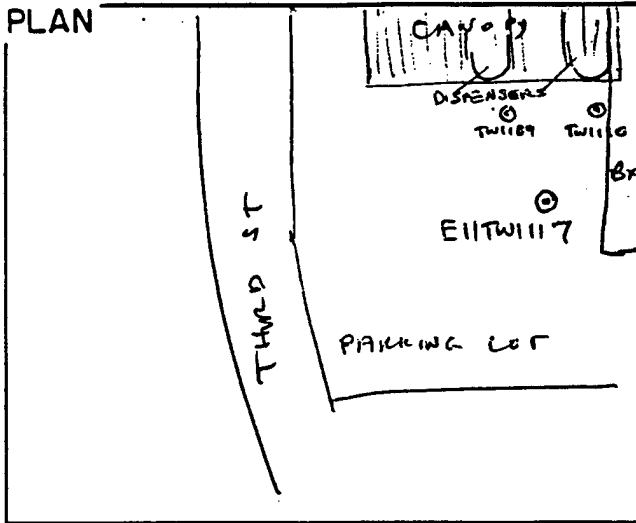

PROJECT EAKER AFB	BORING NO. E11TW117
JOB NO. 3190	LOGGED BY: LRF
PROJ. MGR. GVG	EDITED BY: BFN
DRILLING COMPANY: AW POOL	
DRILL RIG TYPE: Hollow Stem Auger MOBILE BE1	
DRILLING METHOD: Hollow Stem Auger	
DRILLERS NAME: V. BARRAZA	
TOTAL DEPTH (FT.) 12	
TIME STARTED 0815	DATE 12/17/91
TIME COMPLETED 0826	DATE 12/17/91

SAMPLER TYPE	FEET DRIVEN	FEET RECOVERED	SAMPLE CONDITION	FIELD LABORATORY SAMPLE NUMBER	FIXED LABORATORY SAMPLE NUMBER	HNU SCAN (PPM)	LITHOLOGIC CODE	DEPTH (FEET)
BIT	2.0	-	-	-	-	-		1
SPLIT BARREL	5.0	3.5	Good	E1117-1	E11-34-TW117A 07'	400	ML	2-4
SPLIT BARREL	5.0	5.0	Excellent	-	-	30	CL	5-10

GROUND-WATER CONDITION AT COMPLETION OF DRILLING
saturated zone at ± 8.5'

BACKFILLED, TIME 1622 DATE 12-17-91

WEATHER CONDITIONS
CLEAR, MID 30s, 5 mph wind

SURFACE ELEVATION

COMMENTS

ASPHALT @ SURFACE

0-3.5' NO RECOVERY

3.5-5.0' CLAYEY SILT, DARK BROWN, ORGANIC HORIZON, DRY.

5.0'-9.5' SILTY CLAY, REDDISH BROWN w/ DARK MOTTLES BECOMES GREYER w/ DEPTH. MOIST TO WET.

- WET IN MORE SILTY HORIZONS (SEE BELOW)

IRON G. ~~odor~~ odor

- 8.5 to 9.5 WET, FREE WATER VISIBLE IN TWO 4" ZONES

9.5'-12' CLAY, GREY w/ LT BWN MOTTLES, SILTY, SOME REDDISH-BLACK STAINS (Fe?) PLASTIC, MOD. HARD. MOIST



FIELD LOG OF BORING

SHEET 1 OF 1

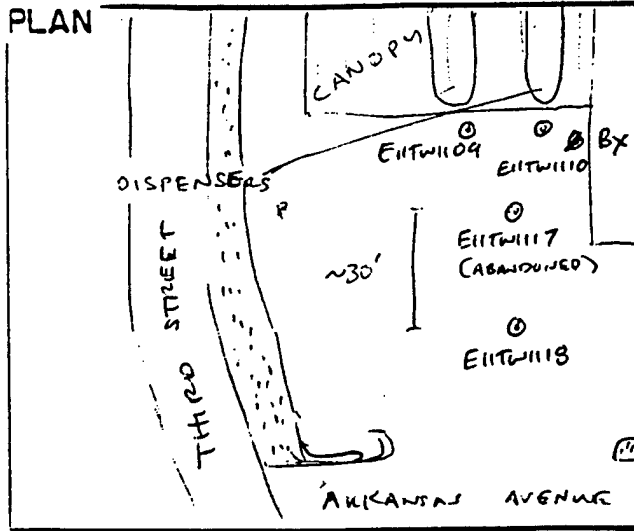

PROJECT EAKER AFB	BORING NO. EITW1118 (ABANDONED BEFORE CASING PLACED IN WELL)
JOB NO. 3K98	LOGGED BY: LME
PROJ. MGR. GVG	EDITED BY: GFN
DRILLING COMPANY: A.W. POOL	
DRILL RIG TYPE: ^{MOBILE} HOLOW STEM AUGER	
DRILLING METHOD: ⁵⁶ hollow stem Auger	
DRILLERS NAME: V. BARRAZA	
TOTAL DEPTH (FT.) 12	
TIME STARTED 0855	DATE 12/17/91
TIME COMPLETED 0920	DATE 12/17/91

SAMPLER TYPE	FEET DRIVEN	FEET RECOVERED	SAMPLE CONDITION	FIELD LABORATORY SAMPLE NUMBER	FIXED LABORATORY SAMPLE NUMBER	HNU SCAN (PPM)	LITHOLOGIC CODE	DEPTH (FEET)
BIT	20	0	-	-	-	-	-	1
S.B.	50	50	-	-	-	3	CL	2-5
S.B.	5.0	5.0	-	118-1; E118-2	-	30	CL CH	6-9.5
S.B.	5.0	5.0	-	118-1; E118-2	-	90	CL	9.5-12

GROUND-WATER CONDITION AT COMPLETION OF DRILLING
Saturated zone at ± 8.5'

BACKFILLED, TIME 16:35 DATE 12-17-91

WEATHER CONDITIONS
CLEAR, MID 40S, LIGHT WIND

SURFACE ELEVATION

COMMENTS

ASPHALT @ SURFACE

2'-5' SILTY CLAY, DARK BROWN TO GREYISH BROWN; SLIGHTLY PLASTIC, MODERATELY HARD, - HYDROCARBON ODOR

5'-9.5' SILTY CLAY, GREYISH BROWN w/ RED MOTTLES, SLIGHTLY MOIST TO WET.

- 8.5' - 9.5' WET IN MORE SILTY ZONES
TWO 3"-4" ZONES HERE w/ FREE WATER

9.5'-12' CLAY, GREY w/ LT REDDISH BROWN MOTTLES, PLASTIC, MOD. HARD, MOIST

FIELD LOG OF BORING (CONT'D.)

SHEET 2 OF 2

SAMPLER TYPE	FEET DRIVEN	FEET RECOVERED	SAMPLE CONDITION	FIELD LAB. SAMPLE NO.	FIXED LAB. SAMPLE NO.	HMUSCAN (PPM)	LITHOLOGIC CODE	DEPTH (FEET)	PROJECT	BORING NO.
									EAKER AFB	TW1119
									JOB NO. 3E98	
SEE PREV. PAGE						0		11		17'
						0		12		12-20' CLAY, GREY; HARD, PLASTIC, ABUNDANT
						0	CL	13		Fe STAINS AND "NODULES" FOLLOWING
						0	CH	14		OLD ROOT HOLES; MINOR SILT; DAMP
S.B.	5.0	5.0	EXCELLENT			0		15		
						0		16		20' SILTY
						0		17		17'-20.5' CLAY, BROWNISH GREY w/ ABUNDANT
						0		18		RED FE STAINS + "NODULES" - SLURRY - 1/2"
						0	CL	19		- WET @ 18'
S.B.	5.0	4.0	EXCELLENT	E1119-02		0		20		20' - 21'
						0		21		20.5' - 21' CLAY, GREY, HARD, PLASTIC, ABUNDANT
						0		22		Fe STAINS AND "NODULES" (SAME AS 12'-17' INTERVAL)
								23		
								24		
								25		TD = 22
								26		
								27		
								28		
								29		
								30		
								31		
								32		
								33		
								34		
								35		
								36		
								37		
								38		
								39		
								40		

NOTES:



FIELD LOG OF BORING

SHEET 1 OF 2

PLAN

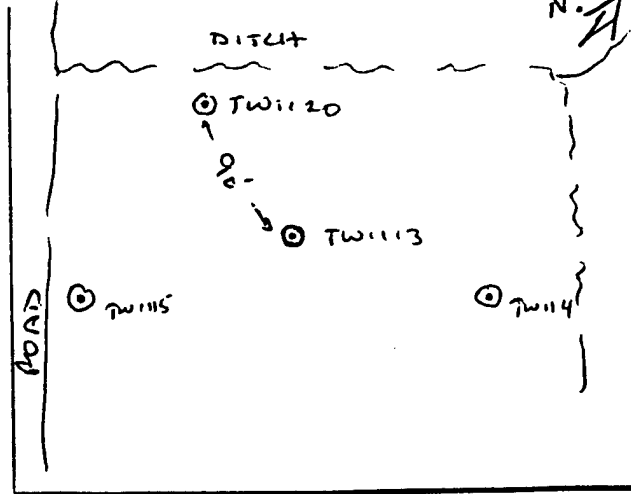

PROJECT EAKER AFB BX Shuttle	BORING NO. TW1120
JOB NO. 3K98	LOGGED BY: JSB
PROJ. MGR. BVG	EDITED BY: BFN
DRILLING COMPANY: A.W Pool	
DRILL RIG TYPE: Mobile B-61	
DRILLING METHOD: Hollow stem auger	
DRILLERS NAME: V. Barazza	
TOTAL DEPTH (FT.) 30	
TIME STARTED 1019	DATE 1-7-92
TIME COMPLETED 1112	DATE 1-7-92

GROUND-WATER CONDITION AT COMPLETION OF DRILLING
Saturated zone at 29' and 11' and 21'

BACKFILLED, TIME DATE 1/9/92 SEE WELL COMPLETE FOR

WEATHER CONDITIONS
cool, 45°, pty cloudy, light breeze

SAMPLER TYPE	FEET DRIVEN	FEET RECOVERED	SAMPLE CONDITION	FIELD LABORATORY SAMPLE NUMBER	FIXED LABORATORY SAMPLE NUMBER	HNU SCAN (PPM)	LITHOLOGIC CODE	DEPTH (FEET)
STRAIGHT AUGER	0.2	2	-	-	-	-	-	1
CONTINUOUS SPLIT SPOON	2.7	5	3.5'	GOOD	-	0%	SS	2.7 - 5
CONTINUOUS SPLIT SPOON	7-12	5	5	EXCELLENT	-	4	CL	7 - 12

SURFACE ELEVATION

COMMENTS

GRASS AT SURFACE

DK BROWN - BROWN SILTY SAND w/ SOME CLAY, ORGANICS ABUNDANT SAND IS MED - COARSE GRAINED WELL SORTED RTZ + ROCK FRAGS. FRIABLE, MOIST 0-6'

DK BROWN - BROWN SILTY CLAY MOIST, MOTTLED, PLASTIC TR SAND 6-9 6-12'

SILTY CLAY ~~TO ABOVE TO 9'~~ (LT BROWN TO BROWN)

SATURATED ZONE AT 9'; (9-9.5)

SOY CLAY AS ABOVE, SATURATED

FIELD LOG OF BORING (CONT'D.)

SHEET 2 OF 2

PROJECT EAKER A6B BORING NO. TW1120
 JOB NO. 3K98

SAMPLER TYPE	FEET DRIVEN	FEET RECOVERED	SAMPLE CONDITION	FIELD LAB. SAMPLE NO.	FIXED LAB. SAMPLE NO.	HNUSCAN (PPM)	LITHOLOGIC CODE	DEPTH (FEET)
CONT SPLIT SPOON	12-17	5	EXCELLENT	-	-	4	SC	11
CONT SPLIT SPOON	17-22	5	EXCELLENT	-	-	0	CL	12
CONT SPLIT SPOON	22-27	5	EXCELLENT	-	-	0	ML	13
AUGUST 10 30' 27-30	3	-	-	-	-	-	-	14
								15
								16
								17
								18
								19
								20
								21
								22
								23
								24
								25
								26
								27
								28
								29
								30
								1
								2
								3
								4
								5
								6
								7
								8
								9
								0

LITHOLOGY FROM 6-12.5 IS PREDOMINANTLY:
 A SANDY CLAY / CLAYEY SD SATURATED
 ZONES HAVE CONSIDERABLE MOLE SAND IN
 THEM (CLAYEY SAND).
 GREY-BROWN MOTTLED CLAY W/TR SILT, SD
 STIFF, PLASTIC - MED. PLASTIC
 12.5-27 (SD STRINGER AT 13)
 CLAY AS ABOVE - MOTTLING
 DECREASES BELOW 18.5' CLAY BELOW
 MUCH GRAYER IN COLOR
 BARREL WET AT 22k
 21 J
 CLAY AS ABOVE, SOFT, (SATURATED)
 PLASTIC, TRACE OXIDE NODULES, AND
 COARSE GRAINED SAND.
 TD = 30' Driller reports
 clay to TD

NOTES:



MW1120

FIELD LOG OF BORING

SHEET 1 OF 2

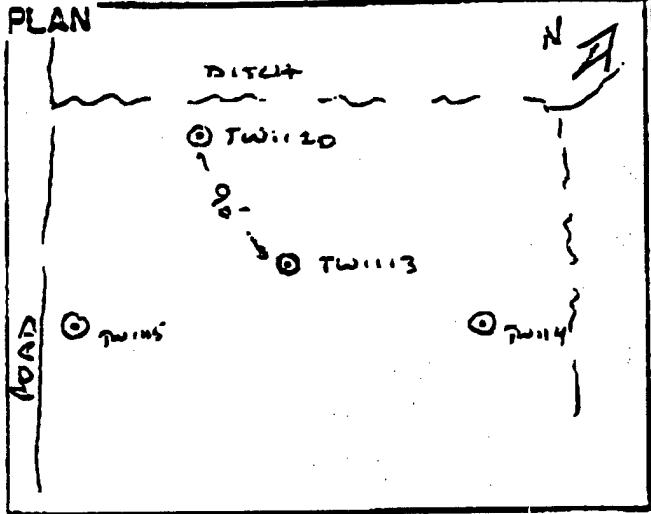

PROJECT EAKER AFB BX Shuttle	BORING NO. TW1120
JOB NO. 3K98	LOGGED BY: JSB
PROJ. MGR. GVG	EDITED BY: BFN
DRILLING COMPANY: A.W Pool	
DRILL RIG TYPE: Mobile B-61	
DRILLING METHOD: Hollow stem auger	
DRILLERS NAME: V. Barozzin	
TOTAL DEPTH (FT.) 30	
TIME STARTED 1019	DATE 1-7-92
TIME COMPLETED 1112	DATE 1-7-92

GROUND-WATER CONDITION AT COMPLETION OF DRILLING
Saturated zone at 29' and 11' and 1'

BACKFILLED, TIME 1/7/92 DATE 1/7/92 SEE WELL COMPLETION FORM

WEATHER CONDITIONS
cool, 45°, pty cloudy, light breeze

SURFACE ELEVATION

COMMENTS

SAMPLER TYPE	FEET DRIVEN	FEET RECOVERED	SAMPLE CONDITION	FIELD LABORATORY SAMPLE NUMBER	FIXED LABORATORY SAMPLE NUMBER	HNU SCAN (PPM)	LITHOLOGIC CODE	DEPTH (FEET)
CONTINUOUS SPLIT SPEED STRAIGHT AUGER	0.2	2	-	-	-	-	-	1
CONTINUOUS SPLIT SPEED	2.7	5	3.5'	GOOD	-	0%	SS	5
CONTINUOUS SPLIT SPEED	7-12	5	5	EXCELLENT	-	0	CL	9
						4	A	10

GRASS AT SURFACE

DK BROWN - BROWN SILTY SAND w/ SOME CLAY. ORGANICS ABUNDANT. SAND IS MED - COARSE GRAINED. WELL SORTED BTZ + LICK FRAGS. FRIABLE, MOIST

0-6'

DK BROWN - BROWN SILTY CLAY. MOIST, MOTTLED, PLASTIC

TR SAND 6-9, 6-12'

SANDY

SILTY CLAY AS ABOVE TO 9' (LT BROWN TO BROWN)

SATURATED ZONE AT 9' (9-9.5')

SOY CLAY AS ABOVE; SATURATED ZONE 11-11.5'

MW1120
SHEET 2 OF 2

FIELD LOG OF BORING (CONT'D.)

										PROJECT	BORING NO.
										ERKED AFB	TW1120
										JOB NO. 3K98	
SAMPLER TYPE	FEET DRIVEN	FEET RECOVERED	SAMPLE CONDITION	FIELD LAB. SAMPLE NO.	FIXED LAB. SAMPLE NO.	SAMPLE NO. HURSCAN (PPM)	LITHOLOGIC CODE	DEPTH (FEET)			
CONT SPLIT SPOON	12-17	5	EXCELLENT	-	-	0304	SC	11	LITHOLOGY FROM 6-12.5 IS PREDOMINANTLY A SANDY CLAY / CLAYEY SD SATURATED ZONES HAVE CONSIDERABLE MOLE SAND IN THEM (CLAYEY SAND)		
CONT SPLIT SPOON	17-22	5	EXCELLENT	-	-	0000	CL	12	GRAY-BROWN MOTTLED CLAY WITH SILT, SD STIFF, PLASTIC - MED. PLASTIC		
CONT SPLIT SPOON	22-27	5	EXCELLENT	-	-	0000	HL	13	12.5-27 (SD STRINGER AT 13')		
AUGER TO 10'	27-30	3	-	-	-	-	-	14	CLAY AS ABOVE - MOTTLED		
								15	DECREASES BELOW 18.5' CLAY BECOME MUCH GRAYER IN COLOR.		
								16	BARREL WET AT 22.6		
								17	21.55		
								18	CLAY AS ABOVE SOFT, (SATURATED)		
								19	PLASTIC, TRACE OXIDE NODULES, AND MED		
								20	COARSE GRAINED SAND.		
								21	ID=30' Driller reports clay to TD		

NOTES:





Halliburton NUS
CORPORATION

FIELD LOG OF BORING

WELL NO. MW1121

SHEET 1 OF 2

PROJECT: EAKER AFB RFI		JOB NO.: 0114		BORING/WELL NO.: MW1121	
		LOGGED BY: BDH		TOTAL DEPTH OF BOREHOLE: 16.7'	
DRILLING CONTRACTOR: Tri-State Testing			SURFACE ELEV.: _____		DATUM: _____
DRILLER'S NAME: Joe T. Leaper			START TIME: 0818		DATE: 4/8/95
DRILL RIG TYPE: CME-55			FINISH TIME: 0920		DATE: 4/8/95
BORING METHOD: HSA			WATER DEPTH: _____		
HOLE DIAMETER: 7 1/4", 10 1/4"			DATE: _____		
SAMPLING METHOD: Continuous			TIME: _____		
HAMMER WGT.: NA		DROP HGT: NA		BACKFILLED. TIME: _____	
DATE: _____		DATE: _____		DATE: _____	
SURFACE CONDITIONS: SNOW			WEATHER: Fair, to 60°F, very strong wind, gusty		

SAMPLE INTERVAL	SAMPLE TYPE	BLOWS / 8-INCHES	INCHES DRIVEN	INCHES RECOVERED	OVA READING (ppm)	MOISTURE	DENSITY	MUNSELL COLOR	LAB SAMPLE NUMBER	DEPTH IN FEET	LITHOLOGY
					0	51	moist	10YR 4/3		1.1'	0.5' - 1.1' silt, clayey, silty, rootless, sh. moist, brown
					0		moist	10YR 6/3		2.7'	1.1 - 2.9 sand, well sorted, fine
		2.7	2.7					10YR 5/3		2.9'	2.7 - 3.2' fine sand, moist, pale brown
					0		moist	10YR 3/2		4.0'	2.9 - 4.0' clay, silty, minor sd., very moist to wet at top, wet @ 3.4'
				3'				10YR 4/3		5.0'	3.4' very dark grayish brn, mottled red/orange brn.
					0		moist			6.0'	4.0' - 13.8' clay, silty, brn, mottled, orange brn, olive gray
					0		moist firm			7.7'	
					0					8.7'	
				5'						13.8'	

NOTES: _____

EDITED BY/DATE: _____



Halliburton NUS
CORPORATION

FIELD LOG OF BORING

WELL NO. MW121

SHEET 2 OF 2

PROJECT: EAKER AFB RFI									JOB NO.: 0114	BORING NO.: MW121	
INTERVAL	SAMPLE TYPE	BLOWS / 8-INCHES	INCHES DRIVEN	RECOVERY	OVA (ppm)	MOISTURE	DENSITY	COLOR	SAMPLE NUMBER	DEPTH IN FEET	LITH.
11.7										11.7	Clay, low silt content, isofine
12.7					0	moist fin			10YR 4/3	12	
13.8										13.8	
14			2.6	2.6	0	moist fin			10YR 4/1	14	13.8' - 16.3' Clay, silty, fine, moist, dk gray, mottled orange br, reddish br along old fractures.
16.3										16	
										17	

NOTES:

EDITED BY/DATE:



Halliburton NUS
CORPORATION

FIELD LOG OF BORING

WELL NO. MW1122

SHEET 1 OF 2

PROJECT: EAKER AFB RFI		JOB NO.: 0114		BORING/WELL NO.: MW1122	
DRILLING CONTRACTOR: Tri-State Testing		LOGGED BY: BDH		TOTAL DEPTH OF BOREHOLE: 17.9	
DRILLER'S NAME: Joe T. Begger		START TIME: 1236		DATE: 4/7/95	
DRILL RIG TYPE: CME-55		FINISH TIME: 1430		DATE: 4/7/95	
BORING METHOD: HSA		WATER DEPTH:			
HOLE DIAMETER: 7 1/4"		DATE:			
SAMPLING METHOD: Continuous		TIME:			
HAMMER WGT.: NA		DROP HGT.: NA		BACKFILLED, TIME: DATE:	
SURFACE CONDITIONS: grass		WEATHER: Fair, upper 70°F, easterly wind			

SAMPLE INTERVAL	SAMPLE TYPE	BLOWS / 6-INCHES	INCHES DRIVEN	INCHES RECOVERED	OVA READING (ppm)	MOISTURE	DENSITY	MUNSELL COLOR	LAB SAMPLE NUMBER	DEPTH IN FEET	LITHOLOGY
0-0.5					0	dry soft	2.51	4/4		1.1	0.5'-1.1' sand, fine grained, silty, sl. clayey, w/ mottles, olive brn.
0.5-1.1					0	sl. moist	2.51	6/4		1.9	1.1'-1.8' sand, fine grained, silty; sl. moist, light yellowish brown
1.1-1.8		2.3	2.3		0	moist	2.51	4/2		3.2	1.8'-3.2' clay, sandy at top, silty, dark grayish brown, mottled orange brn, moist
1.8-3.2					0					4	3.2'-5.1' clay, silty, light olive brown, mottled orange brn, moist
3.2-5.1					0	moist	2.51	5/3		5.1	4.8'-5.3' E11-SU-MW1122A @ 1250
5.1-5.3		5.0	5.0		0	moist	2.51	4/2		6.2	5.1'-6.2' sand, very fine grained to silty, olive brown, moist
5.3-6.2					0	moist	10YR	4/3		7	6.2'-7.7' clay, silty, brown, mottled black, orange brown, moist
6.2-7.7					0	moist	10YR	4/3		7.7	7.7'-9.1' sand very fine grained, silty, light olive brown, moist
7.7-9.1					0	moist	2.51	5/3		9.1	9.1'-11.7' clay, sl. silty, mottled light bluish gray, sl. brn, orange brn, moist
9.1-11.7					0	moist	10YR	6/2		10	

NOTES:

EDITED BY/DATE:

Halliburton NUS

FIELD LOG OF BORING

WELL NO. MW1123

CORPORATION

SHEET 1 OF 2

PROJECT: EAKER AFB RFI		JOB NO.: 0114		BORING/WELL NO.: MW1123	
DRILLING CONTRACTOR: Tri-State Testing		LOGGED BY: G. Miller		TOTAL DEPTH OF BOREHOLE:	
DRILLER'S NAME: John Crawford		SURFACE ELEV.: _____		DATUM: _____	
DRILL RIG TYPE: CME 75		START TIME: 15:35		DATE: 8/11/95	
BORING METHOD: 7 1/4 HSA Overdrilled w/10" HSA		FINISH TIME: 17:30		DATE: 9/11/95	
HOLE DIAMETER: 10"		WATER DEPTH: _____		DATE: _____	
SAMPLING METHOD: Continuous Sampling		TIME: _____		DATE: _____	
HAMMER WGT.: NA		DROP HGT.: NA		BACKFILLED, TIME: _____	
SURFACE CONDITIONS: Grassy		WEATHER: Hot; Humid; 95°F, Sunny		DATE: _____	

SAMPLE INTERVAL	SAMPLE TYPE	BLOWS / 6-INCHES	INCHES DRIVEN	INCHES RECOVERED	OVA READING (ppm)	MOISTURE	DENSITY	MUNSELL COLOR	LAB SAMPLE NUMBER	DEPTH IN FEET	LITHOLOGY	<p style="text-align: center;">SKETCH OF BORING LOCATION</p>
1-5	ES	NA	3FT	3FT	0	Silt	Silt	10YR 3/4		1	<p style="text-align: center;">MATERIAL DESCRIPTION</p> <p>0.5' - 3.0' - Sandy SILT; some clay; dk yellowish brn; color change at 1.5' to 10YR 4/4 yellowish brn then back to 10YR 3/4 at 2ft. sand is fg angular; well sorted. silt. cohesive; multiple roots to 1.5' less roots to 3.0'.</p> <p>3.0' - 8.0' - SILT; trace vfg sand; angular grains; trace clay; yellowish brn; some root casts + roots; mottled w/ 10YR 4/6 dk yellowish brn; appears laminated</p> <p>8.0' - 9.5' - SILT; trace sand; vfg; brn w/ 10YR 5/6 yellowish brn mottling.</p>	
5-10	ES	NA			0			10YR 4/4		2		
10-15	ES	NA			0			10YR 3/4		3		
15-20	ES	NA			0			10YR 6/4		4		
20-25	ES	NA			0			10YR 6/4		5		
25-30	ES	NA			0			10YR 6/4		6		
30-35	ES	NA			0			10YR 6/4		7		
35-40	ES	NA			0			10YR 6/4		8		
40-45	ES	NA			0			10YR 6/4		9		
45-50	ES	NA			0			10YR 6/4		10		

NOTES: _____

EDITED BY/DATE: _____



Halliburton NUS
CORPORATION

FIELD LOG OF BORING

WELL NO. MW1123

SHEET 2 OF 2

PROJECT: EAKER AFB RFI										JOB NO.: 0114		BORING NO.: MW1123		
INTERVAL	SAMPLE TYPE	BLOWS / 9-INCHES	INCHES DRIVEN	RECOVERY	OVA (ppm)	MOISTURE	DENSITY	COLOR	SAMPLE NUMBER	DEPTH IN FEET	LITH.			
					0	WET				11	CL	9.5' - 13.0' - Clayey SILT; trace vfg sand; brn some roots; root casts + worm burrows; mottled w/ 10% R/S 1/6 yellowish brn; silt plastic		
					0					12				
					0					13				
	OS CLAY		SFT	SFT	0	Silt mo	Silt SFT	10% S/2		14	CL	13.0' - 15.0' - CLAY; trace silt; grayish brn w multiple root casts / worm burrows throughout; filled w/ 2.5% 4/6 dk red silty sand material. Some root structures still intact; some chliche; silt plastic		
					0					15				
					0					16				
					0					17				
					0					18				
			15	15	0					19	CL	15.0' - 19.5' - CLAY; trace silt. dark gray; some worm burrows / root cast but not as many as 13.0-15.0'. Worm burrows filled w/ 2.5% 4/6 dk red material; not plastic until ~ 19.0' when more silt is noted. No worm burrows / root casts below 18.0' but some chliche noted.		
					0					20		TD 19.5'		

NOTES:

EDITED BY/DATE:

Halliburton NUS

FIELD LOG OF BORING

WELL NO. MW1124

CORPORATION

SHEET _____ OF _____

PROJECT: EAKER AFB RFI		JOB NO.: 0114		BORING/WELL NO.: MW1124	
DRILLING CONTRACTOR: Tri-State Testing		LOGGED BY: G. Miller		TOTAL DEPTH OF BOREHOLE:	
DRILLER'S NAME: John Crawford		SURFACE ELEV.: _____		DATUM: _____	
DRILL RIG TYPE: CNE-75		START TIME: 0930		DATE: 8/12/95	
BORING METHOD: 7/4 HSA overdrilled w/10' MSP		FINISH TIME: 1.915		DATE: 8/12/95	
HOLE DIAMETER: 10"		WATER DEPTH: _____		DATE: _____	
SAMPLING METHOD: Continuous Sampling		TIME: _____		DATE: _____	
HAMMER WGT.: NA		DROP HGT.: NA		BACKFILLED, TIME: _____	
SURFACE CONDITIONS: Grassy		WEATHER: 10+; Humid; 95°F; Sunny		DATE: _____	

SAMPLE INTERVAL	SAMPLE TYPE	BLOWS / 6-INCHES	INCHES DRIVEN	INCHES RECOVERED	OVA READING (ppm)	MOISTURE	DENSITY	MUNSELL COLOR	LAB SAMPLE NUMBER	DEPTH IN FEET	LITHOLOGY
0.5'	ECG LINE	NA	5 FT	4.5	0	0	0	5YR 5/4	1046	0.5	ML
1.5' - 2.3'					0	0	0	5YR 5/4	1047	1.5	SM SP
2.3' - 2.5'					0	0	0	5YR 5/4	1048	2.3	ML
2.5' - 4.5'					0	0	0	5YR 5/4	1049	2.5	ML
4.5' - 9.0'					0	0	0	5YR 5/4	1050	4.5	ML

SKETCH OF BORING LOCATION

MATERIAL DESCRIPTION

0.5' - 1.5' - Clayey SILT; Some sand fg, angular grains roots; dk yellowish brn.

1.5' - 2.3' - Sandy SILT; Some clay, SH. Cohesive vry dk grayish brn.

2.3' - 2.5' - SAND; vfg; well sorted; angular; brn. laminated w/ yellowish brn. color.

2.5' - 4.5' - Clayey SILT Some muscovite, vry dk grayish brn. color change @ 3.5' to grayish brn w/ 04R4/6 dk red mottling.

4.5' - 9.0' - SILT, greyish brn.

NOTES: drilled to determine if contamination exists in the lower aquifer. EDITED BY: _____ DATE: _____



Halliburton NUS CORPORATION

FIELD LOG OF BORING

WELL NO. NW1124

SHEET OF

PROJECT: EAKER AFB RFI		JOB NO.: 0114		BORING NO.: MW1124							
INTERVAL	SAMPLE TYPE	BLOWS / 6-INCHES	INCHES DRIVEN	RECOVERY	OVA (ppm)	MOISTURE	DENSITY	COLOR	SAMPLE NUMBER	DEPTH IN FEET	LITH.
					0	moist		grey		10.0 - 10.3	CL
					0					10.3 - 12.0	CL
13					0					12.0 - 13.0	CL
			SFT	SFT	0	Silt moist				13.0 - 14.0	CL
					0					14.0 - 15.0	CL
					0					15.0 - 17.0	CL
17					0					17.0 - 19.0	CL
			SFT	SFT	0	moist				19.0 - 21.0	CL
					0					21.0 - 22.5	CL
					0					22.5 - 23.0	CL
23			SFT	4.5	0					23.0 - 24.0	CL
					0					24.0 - 25.0	CL
					0					25.0 - 26.0	CL
					0	SFT				26.0 - 27.0	CL
28					0					27.0 - 28.0	CL
	NW2		10 FT	10 FT	0					28.0 - 29.0	SW
					0					29.0 - 30.0	SW

NO SAMPLES COLLECTED FOR ANALYSIS

trace sand vfg; trace clay, more clay from 10.0' - to 10.3' mottled throughout w/ dk yellowish brn; from 9.0' - 9.0' more clay.

9.0' - 14.0' - silty CLAY, root casts; worm burrows; roots; some intact carbonized root structures; grey w/ 2.5% 4/8 dk red; plastic

14.0' - 18.0' - Clay; trace silt dk grey, some vertical seams filled w/ 10% silt yellowish brn material. Some root casts + worm burrows. One verticle seam ~ 3 inches in length begins at ~16.0'

18' - 23.0' - Clay as above w/ more worm burrows; root casts verticle seams filled w/ 10% silt yellowish brn. One verticle seam extends from 21.5' - 22.5'. Horizontal vfg sandy/silt seam from 22.0' - 22.5'.

23.0' - 26.0' sand/silty CLAY; sand is med grained; angular; well sorted; dk grey w/ some 10% silt mottling; some very small root casts; or worm burrows.

26.0' - 38.0' - SAND; med grained angular; well sorted; qtz. yellowish brn.

Halliburton NUS

FIELD LOG OF BORING

WELL NO. MW1125

SHEET 1 OF 2

CORPORATION

PROJECT: EAKER AFB RFI		JOB NO.: <u>0114</u>		BORING/WELL NO.: <u>MW1125</u>																																																																																																																																																	
		LOGGED BY: <u>G. Miller</u>		TOTAL DEPTH OF BOREHOLE: <u>28'</u>																																																																																																																																																	
DRILLING CONTRACTOR: <u>Tri-State Testing</u>			SURFACE ELEV.: _____		DATUM: _____																																																																																																																																																
DRILLER'S NAME: <u>John Crawford</u>			START TIME: <u>0828</u>		DATE: <u>10/31/95</u>																																																																																																																																																
DRILL RIG TYPE: <u>CME-75</u>			FINISH TIME: <u>0925</u>		DATE: <u>11/01/95</u>																																																																																																																																																
BORING METHOD: <u>7 1/4" HSA Overdrilled w/10" HSA</u>			WATER DEPTH: _____																																																																																																																																																		
HOLE DIAMETER: <u>10"</u>			DATE: _____																																																																																																																																																		
SAMPLING METHOD: <u>Continuous Sampling</u>			TIME: _____																																																																																																																																																		
HAMMER WGT.: <u>NA</u>		DROP HGT: <u>NA</u>		BACKFILLED, TIME: _____																																																																																																																																																	
SURFACE CONDITIONS: <u>Grassy</u>		WEATHER: <u>Overcast; 50's-70's; slt. breeze</u>																																																																																																																																																			
<table border="1"> <thead> <tr> <th>SAMPLE INTERVAL</th> <th>SAMPLE TYPE</th> <th>BLOWS / 6-INCHES</th> <th>INCHES DRIVEN</th> <th>INCHES RECOVERED</th> <th>OVA READING (ppm)</th> <th>MOISTURE</th> <th>DENSITY</th> <th>MUNSELL COLOR</th> <th>LAB SAMPLE NUMBER</th> <th>DEPTH IN FEET</th> <th>LITHOLOGY</th> </tr> </thead> <tbody> <tr> <td colspan="12" style="text-align: center;">NOT SAMPLED OR ANALYZED FOR LITHOLOGY</td> </tr> <tr> <td></td> <td></td> <td></td> <td></td> <td></td> <td></td> <td></td> <td></td> <td></td> <td></td> <td>2</td> <td></td> </tr> <tr> <td></td> <td></td> <td></td> <td></td> <td></td> <td></td> <td></td> <td></td> <td></td> <td></td> <td>4</td> <td></td> </tr> <tr> <td></td> <td></td> <td></td> <td></td> <td></td> <td></td> <td></td> <td></td> <td></td> <td></td> <td>6</td> <td></td> </tr> <tr> <td></td> <td></td> <td></td> <td></td> <td></td> <td></td> <td></td> <td></td> <td></td> <td></td> <td>8</td> <td></td> </tr> <tr> <td></td> <td></td> <td></td> <td></td> <td></td> <td></td> <td></td> <td></td> <td></td> <td></td> <td>10</td> <td></td> </tr> <tr> <td></td> <td></td> <td></td> <td></td> <td></td> <td></td> <td></td> <td></td> <td></td> <td></td> <td>12</td> <td></td> </tr> <tr> <td></td> <td></td> <td></td> <td></td> <td></td> <td></td> <td></td> <td></td> <td></td> <td></td> <td>14</td> <td></td> </tr> <tr> <td></td> <td></td> <td></td> <td></td> <td></td> <td></td> <td></td> <td></td> <td></td> <td></td> <td>16</td> <td></td> </tr> <tr> <td></td> <td></td> <td></td> <td></td> <td></td> <td></td> <td></td> <td></td> <td></td> <td></td> <td>18</td> <td></td> </tr> <tr> <td></td> <td></td> <td></td> <td></td> <td></td> <td></td> <td></td> <td></td> <td></td> <td></td> <td>20</td> <td>CL</td> </tr> </tbody> </table>			SAMPLE INTERVAL	SAMPLE TYPE	BLOWS / 6-INCHES	INCHES DRIVEN	INCHES RECOVERED	OVA READING (ppm)	MOISTURE	DENSITY	MUNSELL COLOR	LAB SAMPLE NUMBER	DEPTH IN FEET	LITHOLOGY	NOT SAMPLED OR ANALYZED FOR LITHOLOGY																						2												4												6												8												10												12												14												16												18												20	CL	<p>SKETCH OF BORING LOCATION</p>		
SAMPLE INTERVAL	SAMPLE TYPE	BLOWS / 6-INCHES	INCHES DRIVEN	INCHES RECOVERED	OVA READING (ppm)	MOISTURE	DENSITY	MUNSELL COLOR	LAB SAMPLE NUMBER	DEPTH IN FEET	LITHOLOGY																																																																																																																																										
NOT SAMPLED OR ANALYZED FOR LITHOLOGY																																																																																																																																																					
										2																																																																																																																																											
										4																																																																																																																																											
										6																																																																																																																																											
										8																																																																																																																																											
										10																																																																																																																																											
										12																																																																																																																																											
										14																																																																																																																																											
										16																																																																																																																																											
										18																																																																																																																																											
										20	CL																																																																																																																																										
MATERIAL DESCRIPTION																																																																																																																																																					
<p>See boring log for MW1124, drilled 8/12/95 for description of lithology from surface to 18.0'. Summary of lithology from surface to 18.0': 0.0' - 1.5' - Clayey SILT 1.5' - 2.3' - Sandy SILT 2.3' - 2.5' - SAND 2.5' - 4.5' - Clayey SILT 4.5' - 9.0' - SILT 9.0' - 14.0' - Silty CLAY 14.0' - 18.0' - CLAY</p>																																																																																																																																																					

NOTES: Drilled to determine extent of Contamin- EDITED BY/DATE: _____
ation in groundwater.

Halliburton NUS CORPORATION

FIELD LOG OF BORING

WELL NO. MW1125

SHEET 2 of 2

PROJECT: EAKER AFB RFI										JOB NO.: 0114		BORING NO.: MW1125		
INTERVAL	SAMPLE TYPE	BLOWS / 6-INCHES	INCHES DRIVEN	RECOVERY	QVA (ppm)	MOISTURE	DENSITY	COLOR	SAMPLE NUMBER	DEPTH IN FEET	LITH.			
		21	5 FT	4.5 FT	0	23.8	1.27	10YR 5/6		21	CL	18.0' - 20.0' - silty CLAY; Clayey SILT; brn. w/ 10YR 5/6 yellowish brn. mottling; some root structures and worm burrows.		
		23	5 FT	2.5 FT	0	24.5	1.27	10YR 5/3		23	CL	20.0' - 21.0' - CLAY; trace silt; dk gray; some brn 10YR 5/3 mottles; silt plastic.		
		25			0	25.0	1.27	10YR 5/6		25	SN	21.0' - 24.5' - Sandy CLAY, dk gray; sand is poorly sorted, some med. and some fg sand; angular; @ 24.0' is a 2 inch verticle sand seam sand is fg to med. grained 5YR 5/8 yellowish red and angular.		
		28								28	SP	24.5' - 25.0' - SAND; well sorted fg sand; angular; gray.		
		32								32		25.0' - 25.5' - SAND; poorly sorted mg-fg; angular qtz; some coarse grains; multi colored grains; overall color 10YR 5/6 yellowish brn.		
		35								35		25.5' - 28.0' - AS above		
		36								36		TD = 28.0 28.5		
		37								37		TD = 38		

Not Described
 28' - 35'
 SAND BASED
 ON SOIL CUTTINGS

NOTES:

EDITED BY/DATE:

Halliburton NUS

FIELD LOG OF BORING

WELL NO. MW1126

CORPORATION

SHEET 2 OF 2

PROJECT: EAKER AFB RFI										JOB NO.: 0114		BORING NO.: MW1126		
INTERVAL	SAMPLE TYPE	BLOWS / 6-INCHES	INCHES DRIVEN	RECOVERY	OVA (ppm)	MOISTURE	DENSITY	COLOR	SAMPLE NUMBER	DEPTH IN FEET	LITH.			
18.0' - 20.3'	LEG 50 EG	NA	SFT		0/0	Silt 70%			NOVA 5/3	21	CH	18.0' - 20.3' - CLAY; silt. plastic dk gray; some root structure + worm burrows.		
20.3' - 21.3'					0/0					22		20.3' - 21.3' - As above w/ color change to brn.		
21.3' - 23.0'			SFT	SFT	0/0	Silt 70%			NOVA 5/3	23		23.0' - 25.0' - CLAY; some sand; poorly sorted; angular med; coarse, + fine grains, dk gray, silt. plastic, some root casts, worm burrows, veins filled w/ yellowish red silt; some w/ R 5/3 (brn), mottles.		
25.0' - 28.0'			SFT	SFT	0/0					25	CL	25.0' - 28.0' - Sandy CLAY; dk gray; angular; fg - coarse grained, veins filled w/ w/ eyes w/ yellowish red silt.		
28.0' - 29.2'					0/0	SAT 100%				28	CH SP S2	28.0 - 29.2' - Sandy CLAY as above, sand is med grained to fine grained.		
29.2' - 33.0'					0/0					29		29.2 - 33.0' - SAND, med grained to fg, poorly sorted angular qtz w/ multi colored grains.		
<p>Not Samples For Drilled Auger By Hollow Stem</p>										30		TD = 41 FD = 33 (well installed at 41.0'), dk 11/2/95		
<p>- THOUGHT TO BE SAND BASED ON DRILL CUTTINGS AND ADJACENT BORE HOLE DATA.</p>										31				
<p>41</p>										32				
<p>41</p>										33				
<p>41</p>										34				

NOTES: DUE TO PROXIMITY OF ADJACENT HOLES & TIME LIMITATIONS, A COMPLETE SOIL DESCRIPTION NOT PERFORMED @ THIS LOCATION

EDITED BY/DATE: JR 9/11/28/95

Halliburton NUS

FIELD LOG OF BORING

WELL NO. MW1127

SHEET 1 OF 2

CORPORATION

PROJECT: EAKER AFB RFI		JOB NO.: <u>0114</u>		BORING/WELL NO.: <u>MW1127</u>							
		LOGGED BY: <u>G. Millar</u>		TOTAL DEPTH OF BOREHOLE: <u>28.0'</u>							
DRILLING CONTRACTOR: <u>Tri-State Testing</u>			SURFACE ELEV.: _____		DATUM: _____						
DRILLER'S NAME: <u>John Crawford</u>			START TIME: <u>1634</u>		DATE: <u>11/02/95</u>						
DRILL RIG TYPE: <u>CME - 75</u>			FINISH TIME: <u>1400</u>		DATE: <u>11/08/95</u>						
BORING METHOD: <u>7/4" HSA Overdrilled w/10" HSA</u>			WATER DEPTH: _____		DATE: _____						
HOLE DIAMETER: <u>10"</u>			TIME: _____		DATE: _____						
SAMPLING METHOD: <u>Continuous Sampling</u>			BACKFILLED, TIME: _____		DATE: _____						
HAMMER WGT.: <u>NA</u>		DROP HGT.: <u>NA</u>		WEATHER: <u>Overcast; breezy; 40's - 50's.</u>							
SURFACE CONDITIONS: <u>Grassy</u>			<p>SKETCH OF BORING LOCATION</p>								
SAMPLE INTERVAL	SAMPLE TYPE	BLOWS / 6-INCHES	INCHES DRIVEN	INCHES RECOVERED	GVA READING (ppm)	MOISTURE	DENSITY	MUNSELL COLOR	LAB SAMPLE NUMBER	DEPTH IN FEET	LITHOLOGY
MATERIAL DESCRIPTION											
See boring log for MW1116 drilled 12/16/91 for lithology from 18.0' surface to 18.0'.											
NOT SAMPLED FOR ANALYSIS FOR LITHOLOGY											
18	CS	NA	SFT	SFT	Oppm	dry	dry	10YR 5/1	10YR 5/1	18	ML
19	CS	NA	SFT	SFT	Oppm	dry	dry	10YR 5/1	10YR 5/1	19	CL
20	CS	NA	SFT	SFT	Oppm	dry	dry	10YR 5/1	10YR 5/1	20	CL

NOTES: Drilled to determine the absence or presence of contamination in sand.

EDITED BY/DATE: JL Miller 11/28/95



Halliburton NUS CORPORATION

FIELD LOG OF BORING

WELL NO. MW1127

SHEET 2 OF 2

PROJECT: EAKER AFB RFI										JOB NO.: 0114		BORING NO.: MW1127	
INTERVAL	SAMPLE TYPE	BLOWS / 8-INCHES	INCHES DRIVEN	RECOVERY	QVA (ppm)	MOISTURE	DENSITY	COLOR	SAMPLE NUMBER	DEPTH IN FEET	LITH.		
	CS CS CS	NA	5FT	5FT	0PPM	51.1 moist	51.1 51.1			21			structures / worm burrows filled w/ 54R 518 yellowish red material (overall color brn.
						moist	51.1 51.1			22	CL		
23										23			19.0' - 24.5' - CLAY, some SILT; root structures / worm burrows, to 21.0' then less root structures but some
23			5FT	3.8						24			104R 513, brn. mottles. Some fg - mg, poorly sorted sand. Overall color dk gray.
						SAT	104R 513			25	SW		
										26			
										27	SP		24.5' - 26.0' - SAND, vfg - fg, well sorted; angular, dk gray; Peat-like material from 25.0' - 25.2' dk black.
28										28			
										29			
										30			26.0' - 29.0' - vfg - mg, SAND, well-sorted, poorly sorted, brn, angular grains, qtz.
										31			
										32			TD = 28.0' 36.5'
										33			
										34			
										35			
										36			
26.5'										37			
										38			
										39			
										40			

Not Sampled For
 Lithology
 Due to
 Drilling
 Problems
 at
 this
 Location

NOTES: Due to proximity of holes & time limitations, a complete soil description not performed at this location.

EDITED BY/DATE: JLG/lls

Halliburton NUS
CORPORATION

FIELD LOG OF BORING

WELL NO. MW1128
SHEET 1 OF 3

PROJECT: EAKER AFB RFI		JOB NO.: 0114		BORING/WELL NO.: MW1128							
		LOGGED BY: G. Millar		TOTAL DEPTH OF BOREHOLE: 40.0'							
DRILLING CONTRACTOR: Tri-State Testing			SURFACE ELEV.: DATUM:								
DRILLER'S NAME: John Crawford			START TIME: 1525 DATE: 11/03/95								
DRILL RIG TYPE: CME-75			FINISH TIME: 1800 DATE: 11/05/95								
BORING METHOD: 7/4" HSA drilled through surface casing			WATER DEPTH:								
HOLE DIAMETER: 12" to 25" 7/4" to 40.0'			DATE:								
SAMPLING METHOD: Continuous Sampling			TIME:								
HAMMER WGT.: NA		DROP HGT.: NA		BACKFILLED, TIME: DATE:							
SURFACE CONDITIONS: Asphalt			WEATHER: Clear; sunny; breezy, 42°F								
SAMPLE INTERVAL	SAMPLE TYPE	BLOWS / 6-INCHES	INCHES DRIVEN	INCHES RECOVERED	OVA READING (ppm)	MOISTURE	DENSITY	MUNSELL COLOR	LAB SAMPLE NUMBER	DEPTH IN FEET	LITHOLOGY
<p>SKETCH OF BORING LOCATION</p>											
MATERIAL DESCRIPTION											
<p>surface to 10.0' not sampled for lithology. See SB1135 for soil description in that interval.</p>											
<p>NOT SAMPLED FOR OVA</p>											

NOTES: Drilled to determine presence or absence of contamination in the sand aquifer.

EDITED BY/DATE: Miller 11/29/95



Halliburton NUS
CORPORATION

FIELD LOG OF BORING

WELL NO. MW1128

SHEET 2 OF 3

PROJECT: EAKER AFB RFI										JOB NO.: 0114	BORING NO.: MW1128	
INTERVAL	SAMPLE TYPE	BLOWS / 8-INCHES	INCHES DRIVEN	RECOVERY	OVA (ppm)	MOISTURE	DENSITY	COLOR	SAMPLE NUMBER	DEPTH IN FEET	LITH.	
10	13/15 10/8	NA	3FT	3FT	10/100	51%	5FT	10YR 5/2		10	ML	10.0' - 11.0' - Clayey silt, brownish gray, mottled w/ 10YR 5/3 brn. mottles.
11					10/100					11		
12					10/100					12	CL	
13					10/100					13		11.0' - 12.5' - CLAY; some silt; brownish gray w/ some 10YR 5/6 yellowish brn. mottles.
14			5FT	5FT	70/15			10YR 5/3		14		Some root casts, worm burrows; some roots still intact; silt. plastic
15					20/15					15	CH	
16					20/15					16		12.5' - 17.0' - CLAY, trace silt; plastic; brn. mottled w/ 10YR 5/6 yellowish brn.
17					5/			10YR 4/1		17		Root casts / worm burrows, some darker mottles, some intact roots.
18			5FT	4.5	100/100	WE				18		
19					100/100					19		
20					100/100					20		17.0' - 25.0' - CLAY, some silt; dk gray; crumbly texture, verticle root casts w/ roots still intact; (some are 4-5 inches in length); along root casts is yellowish red (iron) staining; some 10YR 5/3 brn. mottles; Product sheen observed in veins from 18.5' to 21.2'. Sheen also noted along barrel; Strong odor!
21					100/100					21		
22					100/100					22		
23			2FT	1.5	15/					23		
24										24		
25			3FT	3FT	0/					25		25.0' - 28.0 - CLAY; as above
26					0/					26		
27					0/					27		
28					0/					28		28.0' - TD - SAND; Ag-med grained poorly sorted w/ angular qtz; multi colored grains (wh, blk, coral); overall color brownish gray.
NOT SAMPLED										29	SW	
										30		

EDITED BY: DATE: JREllis 11/28/15

NOTES:



Halliburton NUS CORPORATION

FIELD LOG OF BORING

WELL NO. MW1128

SHEET 3 OF 3

PROJECT: EAKER AFB RFI										JOB NO.: 0114		BORING NO.: MW1128					
INTERVAL	SAMPLE TYPE	BLOWS / 8-INCHES	INCHES DRIVEN	RECOVERY	OVA (ppm)	MOISTURE	DENSITY	COLOR	SAMPLE NUMBER	DEPTH IN FEET	LITH.						
NOT SAMPLED OR ANALYZED FOR LITHOLOGY										31		TD = 40.0'					
										32							
										33							
										34							
										35							
										36							
										37							
										38							
										39							
										40							

NOTES:

EDITED BY/DATE:

DRILLING LOG		DIVISION MRD	INSTALLATION 111K	SHEET 1 OF 2 SHEETS
1. PROJECT ARISTONIA STUDY SAHAR AFB AR		10. SIZE AND TYPE OF BIT 10 1/4 bit		
2. LOCATION (Coordinates or Station) 5' from LIF 62		11. DATUM FOR ELEVATION SHOWN (TBM or MSL)		
3. DRILLING AGENCY USACE-CEMRK-EP-66		12. MANUFACTURER'S DESIGNATION OF DRILL CME 750 / SCARS		
4. HOLE NO. (As shown on drawing title and file number) OVERCORE AP-62		13. TOTAL NO. OF OVER-BURDEN SAMPLES TAKEN	DISTURBED	UNDISTURBED
5. NAME OF DRILLER ROGER HUNTER		14. TOTAL NUMBER CORE BOXES		
6. DIRECTION OF HOLE <input checked="" type="checkbox"/> VERTICAL <input type="checkbox"/> INCLINED _____ DEG. FROM VERT.		15. ELEVATION GROUND WATER	NOT ENCOUNTERED	
7. THICKNESS OF OVERBURDEN —		16. DATE HOLE	STARTED 18 OCT 95	COMPLETED 18 OCT 95
8. DEPTH DRILLED INTO ROCK —		17. ELEVATION TOP OF HOLE		
9. TOTAL DEPTH OF HOLE 10.7		18. TOTAL CORE RECOVERY FOR BORING %		
		19. SIGNATURE OF INSPECTOR Karl... Oldin		

ELEVATION a	DEPTH b	LEGEND c	CLASSIFICATION OF MATERIALS (Description) d	% CORE RECOVERY e	BOX OR SAMPLE NO. f	REMARKS (Drilling time, water loss, depth of weathering, etc., if significant) g
	1		SANDY, clayey fill w/ gravel			6 1/4" ID AUGER Auger thru asphalt & fill - No sample
	2		dk gray to black petroleum odor			SET UP ALJAZIT TO 2311F FROM 3-25-95
	3					3.0
	4		SILTY LEAN CLAY damp - moist mottled gray & orange v. stiff		4.2	inserted inner bbl sampler Ran 2.8 Rec 2.6
	5		medium to stiff petroleum odor		4.5	0.2 fell out of size
	6		becomes sandy w/ fine sand and moist to wet petroleum odor (heavy) stiff			5.8
	7		SILTY CLAY to clayey silt V. STIFF TO STIFF (breaks w/ pressure) cohesive moist gray & orange brown (dk brown areas when cut w/ knife - looks almost a sheen)		7.4 sample	Push probe 7.0' Auger 5' Rec 4.9' made measurements from augered depth of 10.8'; one tenth like petroleum product)
	8		SILT DARK GRAY; wet to SATURATED, medium CLAYEY, COHESIVE petroleum odor		7.8	off of measurements made from tip of probe;
	9		SILTY CLAY STIFF, MOIST GRAY & orange brown iron inclusions		8.1 sample	10.0 on auger = 10.1 on probe
	10				9.0 sample	
					9.5 sample	
					9.9	

Hole No. AP-62

DRILLING LOG		DIVISION MRD	INSTALLATION MPK	SHEET 2 OF 2 SHEETS
1. PROJECT Armstrong Study EAKER AFB		10. SIZE AND TYPE OF BIT		
2. LOCATION (Coordinates or Station) EAKER AFB		11. DATUM FOR ELEVATION SHOWN (TBM or MSL)		
3. DRILLING AGENCY USACE-CENPK-EP-GG		12. MANUFACTURER'S DESIGNATION OF DRILL CME 750		
4. HOLE NO. (As shown on drawing title and file number) AP-62		13. TOTAL NO. OF OVER-BURDEN SAMPLES TAKEN DISTURBED _____ UNDISTURBED _____		
5. NAME OF DRILLER ROGER HUNTER		14. TOTAL NUMBER CORE BOXES		
6. DIRECTION OF HOLE <input checked="" type="checkbox"/> VERTICAL <input type="checkbox"/> INCLINED _____ DEG. FROM VERT.		15. ELEVATION GROUND WATER		
7. THICKNESS OF OVERBURDEN		16. DATE HOLE STARTED 18 OCT 95 COMPLETED 18 OCT 95		
8. DEPTH DRILLED INTO ROCK		17. ELEVATION TOP OF HOLE		
9. TOTAL DEPTH OF HOLE		18. TOTAL CORE RECOVERY FOR BORING %		
		19. SIGNATURE OF INSPECTOR Kathleen O'Brien		

ELEVATION a	DEPTH b	LEGEND c	CLASSIFICATION OF MATERIALS (Description) d	% CORE RECOVERY e	BOX OR SAMPLE NO. f	REMARKS (Drilling time, water loss, depth of weathering, etc., if significant) g
			SILTY CLAY (continued)		10.5	
					FIELD TRPH	
	11				10.7	B.O.H @ 10.7 11.28 → window
	12					
	13					13.33
	14					13.43
	15					Taped hole to 10.3' after augers out NOTE: MAY HAVE TO adjust all depths up 0.1'
	16					Samples 4.2-4.5 FIELD TRPH 7.4-7.8 { TPH, TRPH, 8.7-9.0 { PAH, FIELD 9.5-9.9 { TRPH, 10.6-10.8 FIELD TRPH
	17					No water in hole on 20 OCT; hole backfilled with concrete
	18					
	19					
	20					

DRILLING LOG		DIVISION MRD	INSTALLATION MPK	SHEET 1 OF 1 SHEETS
1. PROJECT ARMSTRONGS VALID STUDY			10. SIZE AND TYPE OF BIT 1 1/4 auger bit 6" inner	
2. LOCATION (Coordinates or Station) EAKER AFB			11. DATUM FOR ELEVATION/SHOWN (TBM or MSL) bbl sample	
3. DRILLING AGENCY CEMRK-EP-GG			12. MANUFACTURER'S DESIGNATION OF DRILL CME 750 / SCAPS	
4. HOLE NO. (As shown on drawing title and title number) OVERCORE AP-67			13. TOTAL NO. OF OVER-BURDEN SAMPLES TAKEN DISTURBED: UNDISTURBED:	
5. NAME OF DRILLER ROGER HUNTER			14. TOTAL NUMBER CORE BOXES	
6. DIRECTION OF HOLE <input type="checkbox"/> VERTICAL <input type="checkbox"/> INCLINED _____ DEG. FROM VERT.			15. ELEVATION GROUND WATER NOT ENCOUNTERED	
7. THICKNESS OF OVERBURDEN			16. DATE HOLE STARTED 19 OCT 95 COMPLETED 19 OCT 95	
8. DEPTH DRILLED INTO ROCK			17. ELEVATION TOP OF HOLE	
9. TOTAL DEPTH OF HOLE 8.6			18. TOTAL CORE RECOVERY FOR BORING	
			19. SIGNATURE OF INSPECTOR K. J. J. 11.2.1 - 01 Jan	

ELEVATION a	DEPTH b	LEGEND c	CLASSIFICATION OF MATERIALS (Description) d	% CORE RECOVERY e	BOX OR SAMPLE NO. f	REMARKS (Drilling time, water loss, depth of weathering, etc., if significant) g
	1		No sample thru fill material			6 1/4" ID Hollow STEEL RUGERS
	2					NS
	3			3.0		
	4		SANDY FILL fine sand damp to moist, loose tan to black wet; some blk fragments at base	4.2	3.8 3.9 SAMPLE	3.8
	5		SILTY CLAY dark green gray moist med-stf	4.8	4.5	
	6		SILTY CLAY gray & orange brown stf to v. stf some f. sand moist Some iron nodules becomes more orange	5.8	5.3 SAMPLE 5.5 SAMPLE	5.0 AUGER 5.0 REC 5.0
	7		becomes gray	7.0	6.8 SAMPLE	made measurements from bottom up
	8		Silty clay v. STIFF, gray & orange brown with fine sand damp to moist	8.3	7.9 SAMPLE 8.3	
	9		clayey silt medium green gray moist to wet			tapered to 8.6 B.O.H @ 8.6
	10					on 20 OCT Hole TAPPED To 7.9', no fluid encountered. Hole backfilled w/ concrete

Hole No. AP-63

DRILLING LOG		DIVISION MRD	INSTALLATION M.F.R.	SHEET 1 OF 1 SHEETS
1. PROJECT ARMSTRONG VALIDATION - LARRY (FB)			10. SIZE AND TYPE OF BIT 10 1/4" auger bit	
2. LOCATION (Coordinates or Station)			11. DATUM FOR ELEVATION SHOWN (TBM or MSL)	
3. DRILLING AGENCY CEMRK-EP-66			12. MANUFACTURER'S DESIGNATION OF DRILL CME-750 / SCAPE & 6" inner bbl	
4. HOLE NO. (As shown on drawing title and file number) OVERCORE AP-63			13. TOTAL NO. OF OVER-BURDEN SAMPLES TAKEN DISTURBED: _____ UNDISTURBED: _____	
5. NAME OF DRILLER ROGER HUNTER			14. TOTAL NUMBER CORE BOXES	
6. DIRECTION OF HOLE <input type="checkbox"/> VERTICAL <input type="checkbox"/> INCLINED _____ DEG. FROM VERT.			15. ELEVATION GROUND WATER NOT ENCOUNTERED	
7. THICKNESS OF OVERBURDEN —			16. DATE HOLE STARTED: 18 OCT 95 COMPLETED: 18 OCT 95	
8. DEPTH DRILLED INTO ROCK —			17. ELEVATION TOP OF HOLE	
9. TOTAL DEPTH OF HOLE 8.7			18. TOTAL CORE RECOVERY FOR BORING %	
			19. SIGNATURE OF INSPECTOR Kotli... 09/11/95	

ELEVATION a	DEPTH b	LEGEND c	CLASSIFICATION OF MATERIALS (Description) d	% CORE RECOVERY e	BOX OR SAMPLE NO. f	REMARKS (Drilling time, water loss, depth of weathering, etc., if significant) g
1	0		SANDY FILL petroleum odor			Auger to 3.8' ↓ 3.8
2	1					
3	2					
4	3					
5	4		SILTY CLAY dk green gray to dk brown STIFF MOIST - wet petroleum odor	5.0		STAFF W/TIP OF PROBE AT 3.77 (3.8') PUSH PROBE, AUGER 5.0' Rec 4.2
5.3	4.7		high angle sand layer blk material; oily appearance at top & bottom	5.7		
6	5		SILTY CLAY gray + orange brown STIFF - V-STIFF MOIST			(petroleum odor throughout sample)
6.6	5.1		SAND 0.07 looks like 0.2' blk at bottom blk may be flat particles	6.7		
7	6		SAND	7.2		Hole measured to 8.7; made measurements from bottom up
7.1	6.6		SILTY CLAY to clay silt iron nodules orange brown + gray MOIST, STIFF - V-STIFF	7.1		
7.2	6.5		SAND 0.07 looks like 0.2' black at bottom contact/ clayey silt	7.2		
8	7		clayey silt dk greenish gray cohesive wet medium - soft some fine sand	8.7		BDH Probe 0.16' below sample
9	8					
10	9					No liquid in hole end of day, about 1.1' at end of 20 OCT; hole backfilled w/ concrete

DRILLING LOG		DIVISION MPB	INSTALLATION MPB	SHEET 1 OF 2 SHEETS
1. PROJECT ARMSTRONG VALID STUDY - EAKER			10. SIZE AND TYPE OF BIT 10 1/4" BIT & 6" TAPERED	
2. LOCATION (Coordinates or Station) EAKER AFB AP			11. DATUM FOR ELEVATION SHOWN (TBM or MSL)	
3. DRILLING AGENCY MRK-EP-66			12. MANUFACTURER'S DESIGNATION OF DRILL CME 751	
4. HOLE NO. (As shown on drawing title and file number) OFFSET AD-63			13. TOTAL NO. OF OVER-BURDEN SAMPLES TAKEN DISTURBED UNDISTURBED	
5. NAME OF DRILLER ROGER HUNTER			14. TOTAL NUMBER CORE BOXES	
6. DIRECTION OF HOLE <input checked="" type="checkbox"/> VERTICAL <input type="checkbox"/> INCLINED _____ DEG. FROM VERT.			15. ELEVATION GROUND WATER NOT EXPOSURE LEVEL	
7. THICKNESS OF OVERBURDEN			16. DATE HOLE STARTED 20 OCT 95 COMPLETED 20 OCT 95	
8. DEPTH DRILLED INTO ROCK			17. ELEVATION TOP OF HOLE	
9. TOTAL DEPTH OF HOLE 13.6			18. TOTAL CORE RECOVERY FOR BORING	
			19. SIGNATURE OF INSPECTOR [Signature]	

ELEVATION a	DEPTH b	LEGEND c	CLASSIFICATION OF MATERIALS (Description) d	% CORE RECOVERY e	BOX OR SAMPLE NO. f	REMARKS (Drilling time, water loss, depth of weathering, etc., if significant) g
	1		(Fill)			NS
	2					
	3					
	4				4.0	
	4.2		black clay	4.2		Run 1 6" split inner bbl sampled
	4.4		SAND wet w/ product fine sand clayey, cohesive black		4.4	
	5.0		high angle contact	5.2	5.2	REC 4.6'
	5.7		SAND yellow stained w/ black		5.3	
	6		SILTY CLAY AND SAND high angle to vertical contact, clay is gray & orange V. STIFF TO HARD has some root hairs or root structures		6.5	← FIELD TR. PH OFF SCALE
	7.1		CLAY becomes SOFTER		7.0	
	7.5				7.5	
	8				8.4	← FIELD TR. PH X 3 8.6
	9		CLY SILT & sand GREEN GRAY COHESIVE, some f sand moist to wet adjacent to fine sand; tan, loose		8.6	
			← SAT SILT w/ adj cont sand black streak		9.4	Run 2
					9.9	

DRILLING LOG		DIVISION MRD	INSTALLATION MPK	SHEET 2 OF 2 SHEETS
1. PROJECT ARMSTRONG VALIDATION STUDY		10. SIZE AND TYPE OF BIT		
2. LOCATION (Coordinates or Station) EAKER AFB, HR		11. DAYUM FOR ELEVATION SHOWN (TBM or MSL)		
3. DRILLING AGENCY CEMRK-EP-66		12. MANUFACTURER'S DESIGNATION OF DRILL CME 750		
4. HOLE NO. (As shown on drawing title and file number) OFFSET AD-63		13. TOTAL NO. OF OVER-BURDEN SAMPLES TAKEN		
5. NAME OF DRILLER ROGER HUNTER		14. TOTAL NUMBER CORE BOXES		
6. DIRECTION OF HOLE <input type="checkbox"/> VERTICAL <input type="checkbox"/> INCLINED _____ DEG. FROM VERT.		15. ELEVATION GROUND WATER		
7. THICKNESS OF OVERBURDEN		16. DATE HOLE		
8. DEPTH DRILLED INTO ROCK		STARTED 20 OCT 95 COMPLETED 20 OCT 95		
9. TOTAL DEPTH OF HOLE		17. ELEVATION TOP OF HOLE		
		18. TOTAL CORE RECOVERY FOR BORING		
		19. SIGNATURE OF INSPECTOR P. J. Allen		

ELEVATION	DEPTH	LEGEND	CLASSIFICATION OF MATERIALS (Description)	% CORE RECOVERY	BOX OR SAMPLE NO.	REMARKS (Drilling time, water loss, depth of weathering, etc., if significant)
	10		(AS ABOVE)	10.1		Run 2
	11	CLAY CHANGES BUT CONTACT W/ SAND IS VERTICAL THROUGHOUT INTERVAL	STIFF CLAY SILTY, iron nod (small) wet → wet, H gray green & orange	10.6		RAN 5 REC 5
	12		SAND + SILTY CLAY sand & clay are side by side sand is stained w/ black SILTY CLAY IS SOFT, SATURATED predominantly green gray, some orange brown → STIFF - V. STF, WET	11.9	120	
	13		FAT CLAY / FINE SAND WET, STIFF STICKY Some silt gray w/ orange brown petroleum odor black hair like organic iron nodules (small)		12A	or lost matter
			FINE SAND - SAT, petroleum odor turns green when dry; loose adjacent to clay clay becomes more orange brown w/ depth			13.6 B.O.H.
						NOTE: SAND TURNS GREENISH UPON drying; can see staining along vertical & high-angle pathways.
						Free product entered hole - approximately 3.0' at end of day. Hole backfilled with concrete. Fuel sample sent to lab for fuel ID.

DRILLING LOG		DIVISION MPC	INSTALLATION MPC	SHEET 1 OF 1 SHEETS
1. PROJECT ACCOMMODATION VALIDATION) EAKET AFB		10. SIZE AND TYPE OF BIT 1 1/4" auger Bit		
2. LOCATION (Coordinates or Station) EAKET AFB AP. - GAS STATION		11. DATUM FOR ELEVATION SHOWN (TBM or MSL)		
3. DRILLING AGENCY CEMPC-EP-66		12. MANUFACTURER'S DESIGNATION OF DRILL C.M.E. 750 w/ 6 1/4" ID Hollow Stems		
4. HOLE NO. (As shown on drawing title and file number) OFFSET AD 68		13. TOTAL NO. OF OVER-BURDEN SAMPLES TAKEN DISTURBED UNDISTURBED		
5. NAME OF DRILLER ROGER HUNTER		14. TOTAL NUMBER CORE BOXES		
6. DIRECTION OF HOLE <input type="checkbox"/> VERTICAL <input type="checkbox"/> INCLINED _____ DEG. FROM VERT.		15. ELEVATION GROUND WATER NOT ENCOUNTERED		
7. THICKNESS OF OVERBURDEN		16. DATE HOLE STARTED 20 OCT 95 COMPLETED 20 OCT 95		
8. DEPTH DRILLED INTO ROCK		17. ELEVATION TOP OF HOLE		
9. TOTAL DEPTH OF HOLE 8.6		18. TOTAL CORE RECOVERY FOR BORING %		
		19. SIGNATURE OF INSPECTOR [Signature]		

ELEVATION a	DEPTH b	LEGEND c	CLASSIFICATION OF MATERIALS (Description) d	% CORE RECOVERY e	BOX OR SAMPLE NO. f	REMARKS (Drilling time, water loss, depth of weathering, etc., if significant) g
	1		(Fill)			NS
	2					
	3					
	3.7		SANDY CLAY Crumbly texture petroleum odor dk brown to blk V. STIFF TO STIFF, moist w/wet surfaces	3.7	3.4	6" inner bit
	4				ANALYTICAL A.4	RAN 5.0 REC 5.0
	5		becomes mottled w/ orange brown & gray (lighter v. STIFF, crumbly		A.5 ANALYTICAL	
	5.0					
	6		SILTY CLAY TO CLY SILT gray - orange brown moist w/wet surfaces white root hairs crumbly structure w/ fine sand	5.8	5.8	5.5-6.0 ANALYTICAL SAMPLE
	6.5		SILT w/ CLAY some fine sand, dk medium wet to sat some iron staining		6.1	6.0-6.5 (?)
	7		→ mottled w/ increase in clay		6.5: ANALYTICAL	
	7.2				7.0	
	7.6		SILT, clayey green gray, sdy, med, moist to wet		7.2 GEOTECH Soils	7.5-8.0 ANALYTICAL SAMPLE
	7.9		SILT, clayey - clay w/ fine white root hairs STIFF, becomes darker gray → becomes sandy		7.6	
	8					
	9					
	10					top to 8.6 6.0. 11
						No WATER IN HOLE @ end of day, backfilled w/ concrete

Hole No. AP-67

DRILLING LOG		DIVISION MRD	INSTALLATION MRK	SHEET 1 OF / SHEETS
1. PROJECT ARMSTRONG STUDY EAKER AFB, AR.		10. SIZE AND TYPE OF BIT 1 1/4 auger bit / 1 1/2" inner bit		
2. LOCATION (Coordinates or Station)		11. DATUM FOR ELEVATION SHOWN (TBM or MSL)		
3. DRILLING AGENCY USACE-CAMP K-EP-615		12. MANUFACTURER'S DESIGNATION OF DRILL CME 750 / SCAPS		
4. HOLE NO. (As shown on drawing title and file number) OVERCORE AP-68		13. TOTAL NO. OF OVER-BURDEN SAMPLES TAKEN		
5. NAME OF DRILLER ROGER HUNTER		14. TOTAL NUMBER CORE BOXES		
6. DIRECTION OF HOLE <input type="checkbox"/> VERTICAL <input type="checkbox"/> INCLINED _____ DEG. FROM VERT.		15. ELEVATION GROUND WATER NOT ENCOUNTERED		
7. THICKNESS OF OVERBURDEN		16. DATE HOLE 19 OCT 95 STARTED 19 OCT 95 COMPLETED		
8. DEPTH DRILLED INTO ROCK		17. ELEVATION TOP OF HOLE		
9. TOTAL DEPTH OF HOLE 10'		18. TOTAL CORE RECOVERY FOR BORING 2		
		19. SIGNATURE OF INSPECTOR		

ELEVATION	DEPTH	LEGEND	CLASSIFICATION OF MATERIALS (Description)	% CORE RECOVERY	BOX OR SAMPLE NO.	REMARKS (Drilling time, water loss, depth of weathering, etc., if significant)
1						<p>No fluid in hole on 20 OCT; bottom taped at 8.1 hole back filled w/ concrete</p> <p>NOTE: USED TAPE CHECK OF 9.8 AND made measurements from bottom up; window was 0.3' below shoe which removed from hole.</p> <p>R.C. 1.9</p>
2						
3			SAND DAMP, FINE, GRAY to black FILL 2.9 3.4			
4			SILTY CLAY STIFF, DAMP to moist DARK GRAY 4.3			
5			CLAYEY SILT medium, cohesive MOIST DARK GREEN GRAY 5.5 SOFT, IRON STAINED WET			
6			SILTY CLAY some sand V. STIFF MOIST Lt GRAY + orange brown some IRON STAINING + iron nodules 7.0	5.8 FIELD TRAIL 5.9		
7			CLAY SILT w/ f. sand, cohesive greenish gray w/ some iron stain MOIST STIFF - V. STIFF 7.8	6.0 6.5		
8			SILTY CLAY - CLAY SILT STIFF, MOIST gray w/ orange brown mottles 8.5	8.2		
9			CLAYEY SILT cohesive, greenish gray wet, stiff → becomes saturated, medium 9.5	8.8 9.5 FIELD TRAIL		
10			B.O.H. 9.8	9.8		

APPENDIX B - 1B

WELL INSTALLATION LOGS

BX SHOPPETTE

Source: Halliburton NUS 1992 and 1995.

FIELD WELL COMPLETION FORM TW1101

JOB NAME: EAKER AFB Bx SHOPETTE

JOB NUMBER: 31498 PROJECT MANAGER: GVG

LOGGED BY: JSB EDITED BY: BFR

WELL NAME: TW1101 DATE: 12/11/91

DRILLING COMPANY: A.W. POOL

EQUIPMENT: 1 1/4 INCH HOLLOW STEM AUGER DRILLER: V. BARAZZA
 INCH ROTARY WASH HOURS DRILLED: 1

GALLONS OF WATER USED DURING DRILLING: NONE GALLONS

METHOD OF DECONTAMINATION PRIOR TO DRILLING: PRESSURE STEAM

DEVELOPMENT SEE WELL DEVELOPMENT FORM

METHOD OF DEVELOPMENT:

DEVELOPMENT BEGAN DATE: TIME: DATE:

YIELD: GPM TIME: FROM TO DATE:

YIELD: GPM TIME: FROM TO DATE:

YIELD: GPM TIME: FROM TO DATE:

YIELD: GPM TIME: FROM TO DATE:

TOTAL WATER REMOVED DURING DEVELOPMENT: GALLONS

DESCRIPTION OF TURBIDITY AT END OF DEVELOPMENT: CLEAR SLIGHTLY CLOUDY

MOD. TURBID VERY MUDDY

ODOR OF WATER:

WATER DISCHARGED TO: GROUND SURFACE TANK TRUCK

STORM SEWERS STORAGE TANK

DRUMS OTHER

DEPTH TO WATER AFTER DEVELOPMENT: FEET

MATERIALS USED

3 100* SACKS OF COLORADO SILICA 20/40 SAND

~20 SACKS OF _____ CEMENT

50 GALLONS OF GROUT USED (PORTLAND TYPE II w/BENTONITE)

50 SACKS OF POWDERED BENTONITE

15 POUNDS OF BENTONITE PELLETS

15 FEET OF 2 INCH PVC BLANK CASING

10 FEET OF 2 INCH PVC-SLOTTED SCREEN

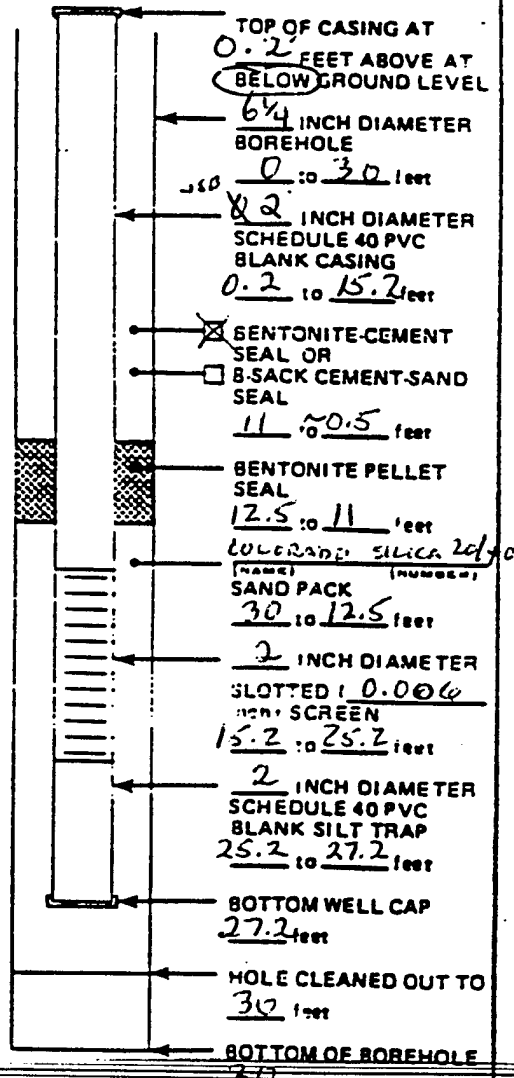
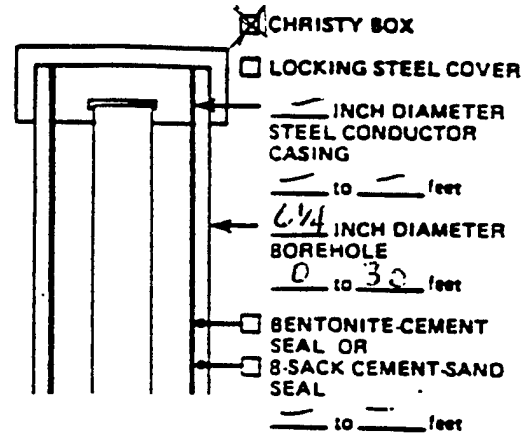

YARD³ CEMENT-SAND (REDI-MIX) USED

CONCRETE PUMPER USED? NO YES

NAME _____

WELL COVER USED: LOCKING STEEL COVER

CHRISTY BOX

OTHER _____

ADDITIONAL INFORMATION:

NOTE: MATERIALS WERE

NOT MEASURED BEFORE

GOING IN WELL JSB

FIELD WELL COMPLETION FORM

JOB NAME: EAKER AAS BX

JOB NUMBER: 3K98 PROJECT MANAGER: GK

LOGGED BY: JSB EDITED BY: BFH

WELL NAME: T-1102 DATE: 12-11-91

DRILLING COMPANY: AWPOOL

EQUIPMENT: 6 1/4 INCH HOLLOW STEM AUGER DRILLER: V. BARAZZA
 INCH ROTARY WASH HOURS DRILLED: .66

GALLONS OF WATER USED DURING DRILLING: NONE GALLONS

METHOD OF DECONTAMINATION PRIOR TO DRILLING: PRESSURE STEAM

DEVELOPMENT SEE WELL DEVELOPMENT FORM

METHOD OF DEVELOPMENT:

DEVELOPMENT BEGAN DATE:	TIME:	DATE:
YIELD: GPM	TIME: FROM TO	DATE:
YIELD: GPM	TIME: FROM TO	DATE:
YIELD: GPM	TIME: FROM TO	DATE:
YIELD: GPM	TIME: FROM TO	DATE:

TOTAL WATER REMOVED DURING DEVELOPMENT: _____ GALLONS

DESCRIPTION OF TURBIDITY AT END OF DEVELOPMENT: CLEAR SLIGHTLY CLOUDY
 MOD. TURBID VERY MUDDY

ODOR OF WATER:

WATER DISCHARGED TO: GROUND SURFACE TANK TRUCK
 STORM SEWERS STORAGE TANK
 DRUMS OTHER _____

DEPTH TO WATER AFTER DEVELOPMENT: _____ FEET

MATERIALS USED

- 2.5 SACKS OF SILICA GRADE SAND
- _____ SACKS OF _____ CEMENT
- ~20 GALLONS OF GROUT USED (PORTLAND TYPE II w/ BENTONITE)
- _____ SACKS OF POWDERED BENTONITE
- 50 POUNDS OF BENTONITE PELLETS
- 12.4 FEET OF 2 INCH PVC BLANK CASING
- 16.2 FEET OF _____ INCH PVC SLOTTED SCREEN

YARD CEMENT-SAND (REDI-MIX) ORDERED _____
 YARD CEMENT-SAND (REDI-MIX) USED _____

CONCRETE PUMPER USED? NO YES

NAME _____

WELL COVER USED: LOCKING STEEL COVER
 CHRISTY BOX
 OTHER _____

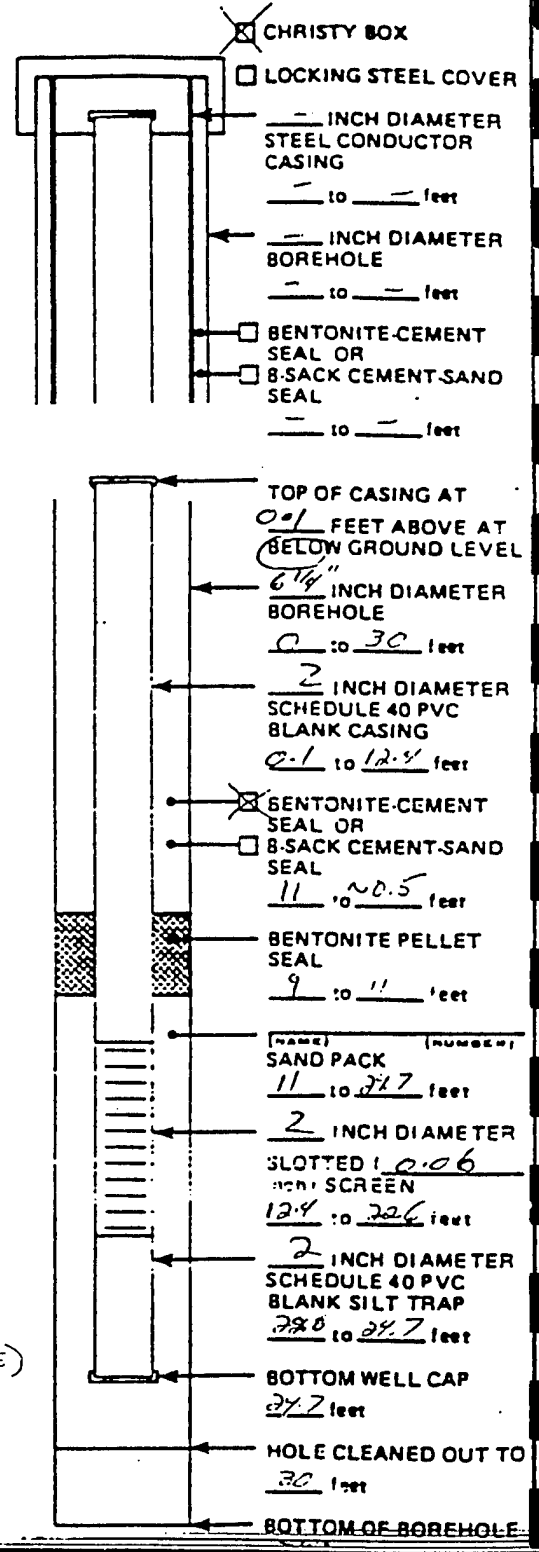

NOT TO SCALE

ADDITIONAL INFORMATION: _____
Borehole cleaned to 2'
per to setting well

FIELD WELL COMPLETION FORM

JOB NAME: EAKER AFB BX
 JOB NUMBER: 3K98 PROJECT MANAGER: GVB
 LOGGED BY: JSB EDITED BY: BFN
 WELL NAME: TW1103 DATE: 12/11/91
 DRILLING COMPANY: AW POOL
 EQUIPMENT: 6 1/4 INCH HOLLOW STEM AUGER DRILLER: V. BARAZZA
 INCH ROTARY WASH HOUR DRILLED: 1

GALLONS OF WATER USED DURING DRILLING: NONE GALLONS

METHOD OF DECONTAMINATION PRIOR TO DRILLING: PRESSURE STEAM

DEVELOPMENT SEE WELL DEVELOPMENT FORM

METHOD OF DEVELOPMENT:

YIELD:	GPM	TIME:	FROM	TO	DATE:

TOTAL WATER REMOVED DURING DEVELOPMENT: _____ GALLONS

DESCRIPTION OF TURBIDITY AT END OF DEVELOPMENT: CLEAR SLIGHTLY CLOUDY
 MOD. TURBID VERY MUDDY

ODOR OF WATER:

WATER DISCHARGED TO: GROUND SURFACE TANK TRUCK
 STORM SEWERS STORAGE TANK
 DRUMS OTHER _____

DEPTH TO WATER AFTER DEVELOPMENT: _____ FEET

MATERIALS USED

3.5 SACKS OF Silica Grade SAND
 _____ SACKS OF _____ CEMENT
 _____ GALLONS OF GROUT USED
 _____ SACKS OF POWDERED BENTONITE
50 POUNDS OF BENTONITE PELLETS
15 FEET OF 2 INCH PVC BLANK CASING
10 FEET OF 2 INCH PVC SLOTTED SCREEN

_____ YARD³ CEMENT-SAND (REDI-MIX) ORDERED

_____ YARD³ CEMENT-SAND (REDI-MIX) USED

CONCRETE PUMPER USED? NO YES

NAME _____

WELL COVER USED: LOCKING STEEL COVER
 CHRISTY BOX
 OTHER _____

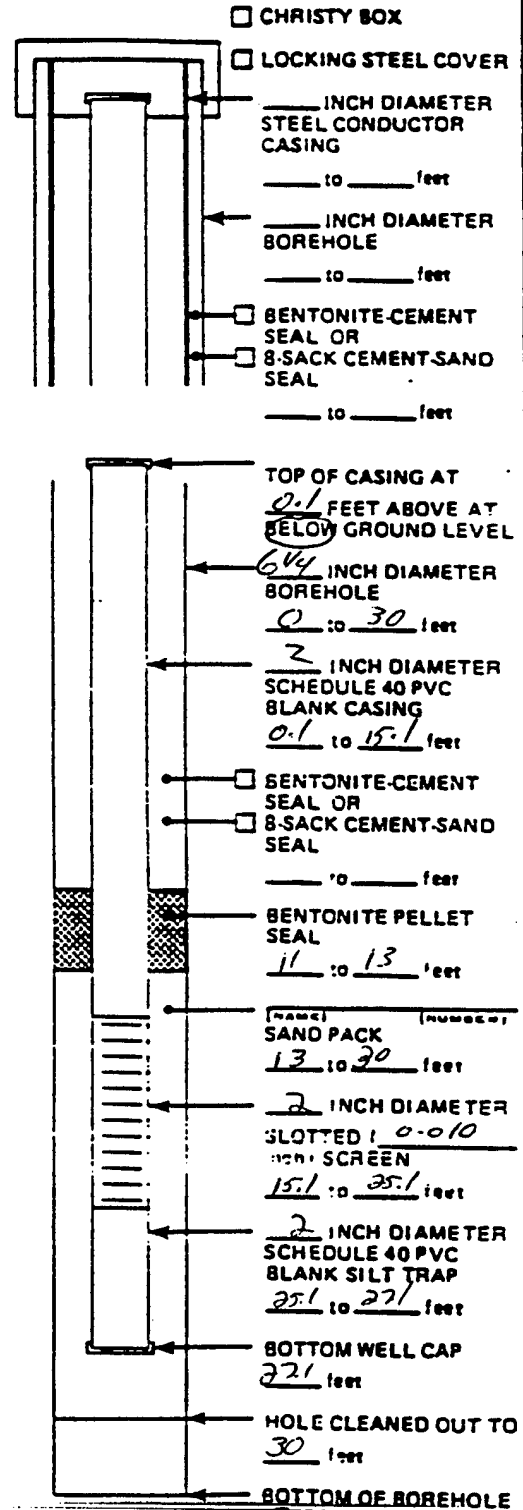

ADDITIONAL INFORMATION:

WELL ABANDONED 1/8/92

FIELD WELL COMPLETION FORM

JOB NAME: EAKER AFB

JOB NUMBER: 3K98 PROJECT MANAGER: GVG

LOGGED BY: BEN EDITED BY: BEN

WELL NAME: TW1104 DATE: 12-11-91

DRILLING COMPANY: A.W. POOL

EQUIPMENT: 6 1/4 INCH HOLLOW STEM AUGER DRILLER: V. BARREZA
 _____ INCH ROTARY WASH HOURS DRILLED: _____

GALLONS OF WATER USED DURING DRILLING: none GALLONS

METHOD OF DECONTAMINATION PRIOR TO DRILLING: pressure steam

DEVELOPMENT SEE DEVELOPMENT FORM

METHOD OF DEVELOPMENT: _____

YIELD:	TIME:	DATE:
GPM	FROM TO	

TOTAL WATER REMOVED DURING DEVELOPMENT: _____ GALLONS

DESCRIPTION OF TURBIDITY AT END OF DEVELOPMENT: CLEAR SLIGHTLY CLOUDY
 MOD. TURBID VERY MUDDY

ODOR OF WATER: _____

WATER DISCHARGED TO: GROUND SURFACE TANK TRUCK
 STORM SEWERS STORAGE TANK
 DRUMS OTHER _____

DEPTH TO WATER AFTER DEVELOPMENT: _____ FEET

MATERIALS USED

- 2.5 SACKS OF Silica Grade SAND
- _____ SACKS OF _____ CEMENT
- 1.20 GALLONS OF GROUT USED (PORTLAND TYPE I w/BENTONITE)
- _____ SACKS OF POWDERED BENTONITE
- 50 POUNDS OF BENTONITE PELLETS
- 14 FEET OF 2 INCH PVC BLANK CASING
- 10 FEET OF 2 INCH PVC SLOTTED SCREEN

_____ YARD CEMENT-SAND (RED-MIX) ORDERED

_____ YARD CEMENT-SAND (RED-MIX) USED

CONCRETE PUMPER USED? NO YES

NAME _____

WELL COVER USED: LOCKING STEEL COVER
 CHRISTY BOX
 OTHER _____

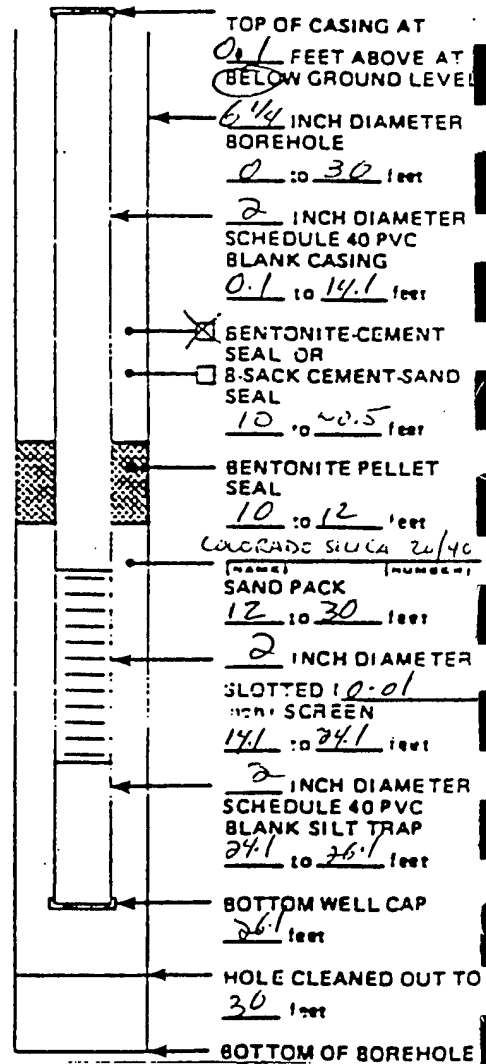
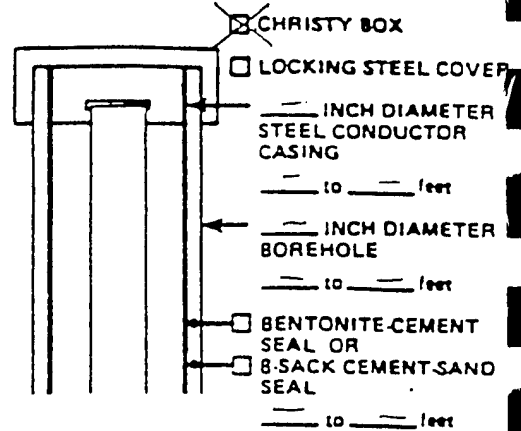

NOT TO SCALE

ADDITIONAL INFORMATION: _____

FIELD WELL COMPLETION FORM

JOB NAME: EAKER AFR

JOB NUMBER: 3K98 PROJECT MANAGER: G.V.G.

LOGGED BY: BFN EDITED BY: BFN/JSB

WELL NAME: E11TW05 DATE: 12/13/91

DRILLING COMPANY: Pool Drilling

EQUIPMENT: 6 1/4 INCH HOLLOW STEM AUGER DRILLER: V. Burrazes
 INCH ROTARY WASH HOURS DRILLED: 246

GALLONS OF WATER USED DURING DRILLING: NONE GALLONS

METHOD OF DECONTAMINATION PRIOR TO DRILLING: Stem cleaned

DEVELOPMENT SEE LOGBOOK; WELL CONTAINS FREE

METHOD OF DEVELOPMENT: PRODUCT; WAS NOT DEVELOPED

YIELD:	GPM	TIME: FROM	TO	DATE:

TOTAL WATER REMOVED DURING DEVELOPMENT: _____ GALLONS

DESCRIPTION OF TURBIDITY AT END OF DEVELOPMENT: CLEAR SLIGHTLY CLOUDY
 MOD. TURBID VERY MUDDY

ODOR OF WATER: _____

WATER DISCHARGED TO: GROUND SURFACE TANK TRUCK
 STORM SEWERS STORAGE TANK
 DRUMS OTHER _____

DEPTH TO WATER AFTER DEVELOPMENT: _____ FEET

MATERIALS USED

- 2.5 SACKS OF SILICA Grade 20/40 SAND
- _____ SACKS OF _____ CEMENT
- 220 GALLONS OF GROUT USED (PORTLAND TYPE II CEMENT / BENTONITE)
- _____ SACKS OF POWDERED BENTONITE
- 50 POUNDS OF BENTONITE PELLETS
- 13.1 FEET OF 2 INCH PVC-BLANK-CASING

10 _____

_____ YARD³ CEMENT-SAND (REDI-MIX) ORDERED

_____ YARD³ CEMENT-SAND (REDI-MIX) USED

CONCRETE PUMPER USED? NO YES

NAME _____

WELL COVER USED: LOCKING STEEL COVER
 CHRISTY BOX
 OTHER _____

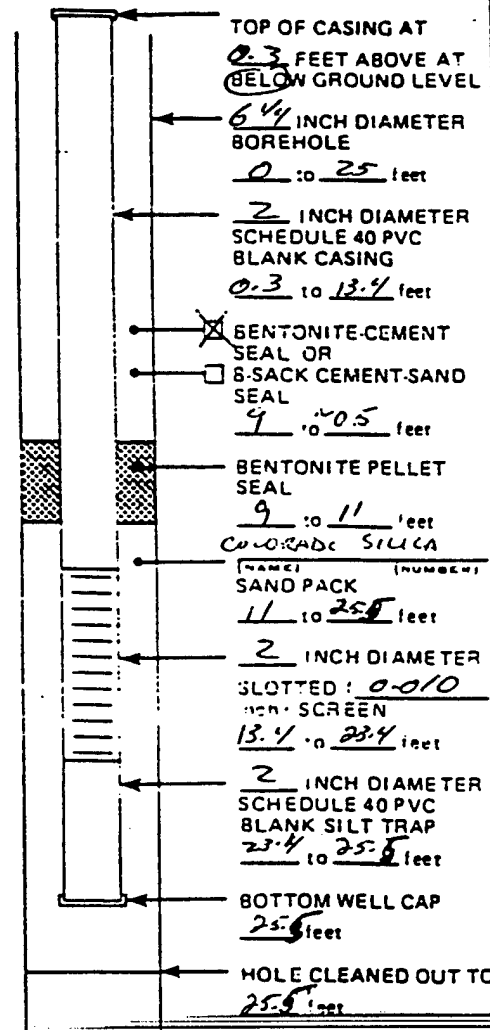
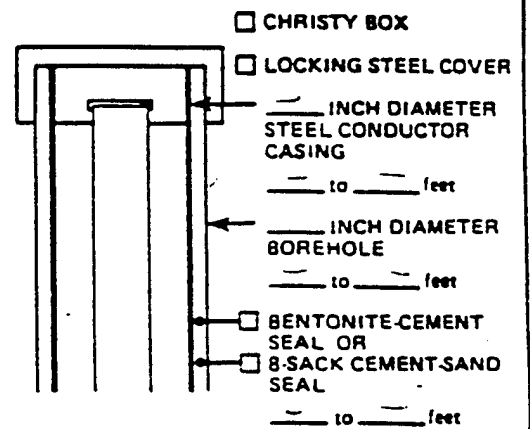

NOT TO SCALE

ADDITIONAL INFORMATION: _____

FIELD WELL COMPLETION FORM

JOB NAME: EAKER AFB

JOB NUMBER: 3K98 PROJECT MANAGER: George Gartzoff

LOGGED BY: LRE EDITED BY: BFN

WELL NAME: E112W06 DATE: 12/13/91

DRILLING COMPANY: Pool Drilling

EQUIPMENT: 6 1/4 INCH HOLLOW STEM AUGER DRILLER: V. Barazza
 INCH ROTARY WASH HOURS DRILLED: 1.2

GALLONS OF WATER USED DURING DRILLING: NONE GALLONS

METHOD OF DECONTAMINATION PRIOR TO DRILLING: HIGH-PRESSURE STEAM

DEVELOPMENT SEE WELL DEVELOPMENT FORM

METHOD OF DEVELOPMENT:

YIELD:	GPM	TIME:	FROM	TO	DATE:

TOTAL WATER REMOVED DURING DEVELOPMENT: _____ GALLONS

DESCRIPTION OF TURBIDITY AT END OF DEVELOPMENT: CLEAR SLIGHTLY CLOUDY
 MOD. TURBID VERY MUDDY

ODOR OF WATER:

WATER DISCHARGED TO: GROUND SURFACE TANK TRUCK
 STORM SEWERS STORAGE TANK
 DRUMS OTHER

DEPTH TO WATER AFTER DEVELOPMENT: _____ FEET

MATERIALS USED

- 2.5 SACKS OF 20/40 SAND
- _____ SACKS OF _____ CEMENT
- ~20 GALLONS OF GROUT USED (CEMENT/BENTONITE)
- _____ SACKS OF POWDERED BENTONITE
- 50 POUNDS OF BENTONITE PELLETS
- 13.20 FEET OF 2 INCH PVC BLANK CASING

~~10.20~~
~~2.00~~

_____ YARD CEMENT-SAND (REDI-MIX) ORDERED
 _____ YARD³ CEMENT-SAND (REDI-MIX) USED

CONCRETE PUMPER USED? NO YES

NAME _____

WELL COVER USED: LOCKING STEEL COVER
 CHRISTY BOX
 OTHER _____

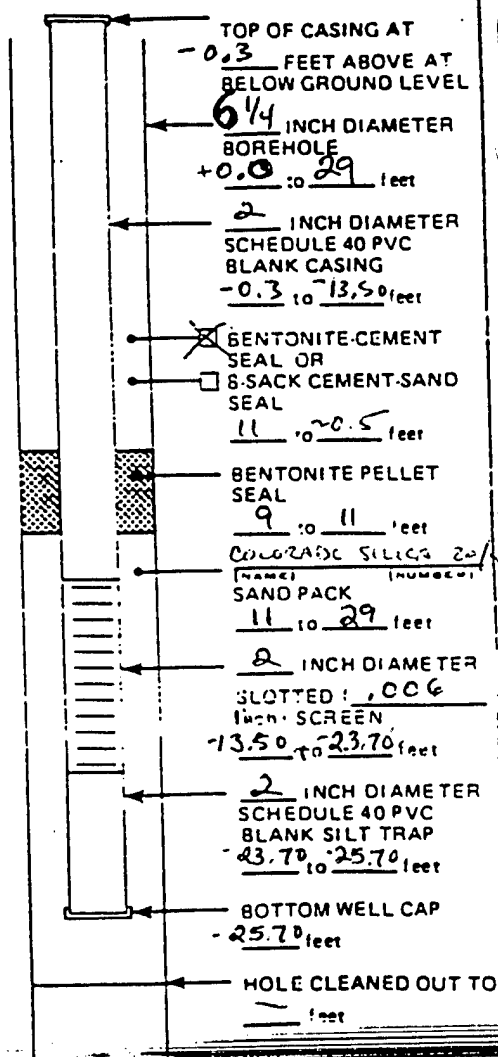
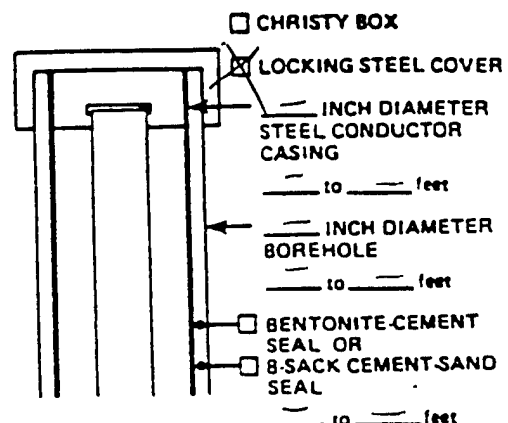

NOT TO SCALE

ADDITIONAL INFORMATION: _____

FIELD WELL COMPLETION FORM

JOB NAME: EAKER AFB

JOB NUMBER: 3K98 PROJECT MANAGER: GVG

LOGGED BY: JMK EDITED BY: G.F.N.

WELL NAME: EITW07 DATE: 12/13/91

DRILLING COMPANY: A.W. POOL

EQUIPMENT: 7/4 INCH HOLLOW STEM AUGER DRILLER: V. BARRAZZO
 6/4 INCH ROTARY WASH HOURS DRILLED: 0.75

GALLONS OF WATER USED DURING DRILLING: NONE GALLONS

METHOD OF DECONTAMINATION PRIOR TO DRILLING: PRESSURE STEAM

DEVELOPMENT SEE DEVELOPMENT FORM

METHOD OF DEVELOPMENT:

DEVELOPMENT BEGAN DATE:	TIME:	DATE:
YIELD: GPM	TIME: FROM TO	DATE:
YIELD: GPM	TIME: FROM TO	DATE:
YIELD: GPM	TIME: FROM TO	DATE:
YIELD: GPM	TIME: FROM TO	DATE:

TOTAL WATER REMOVED DURING DEVELOPMENT: _____ GALLONS

DESCRIPTION OF TURBIDITY AT END OF DEVELOPMENT: CLEAR SLIGHTLY CLOUDY
 MOD. TURBID VERY MUDDY

ODOR OF WATER: _____

WATER DISCHARGED TO: GROUND SURFACE TANK TRUCK
 STORM SEWERS STORAGE TANK
 DRUMS OTHER _____

DEPTH TO WATER AFTER DEVELOPMENT: _____ FEET

MATERIALS USED

2 1/2 SACKS OF Colorado 20/40 SAND

_____ SACKS OF _____ CEMENT

_____ GALLONS OF GROUT USED

_____ SACKS OF POWDERED BENTONITE

50 POUNDS OF BENTONITE PELLETS

14.92' FEET OF 2 INCH PVC BLANK CASING

10.05' 14.92' FEET OF 2 INCH PVC SLOTTED SCREEN

2.00' FEET OF _____

_____ YARD³ CEMENT-SAND (REDI-MIX) ORDERED

_____ YARD³ CEMENT-SAND (REDI-MIX) USED

CONCRETE PUMPER USED? NO YES

NAME _____

WELL COVER USED: LOCKING STEEL COVER
 CHRISTY BOX
 OTHER _____

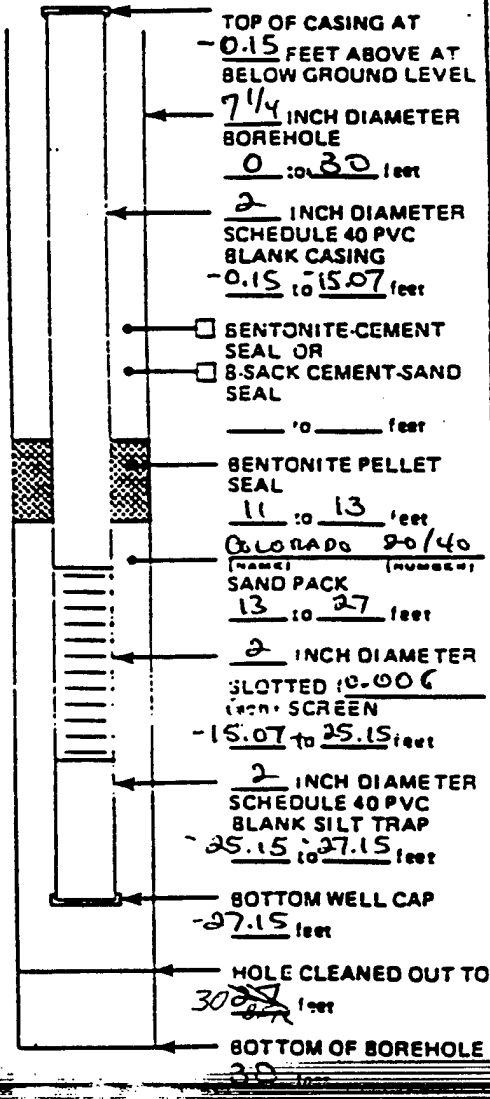
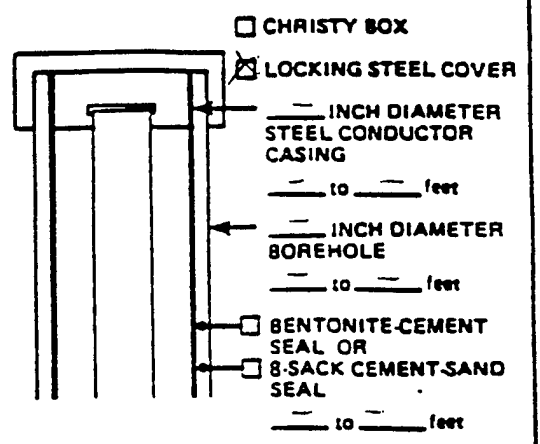

NOT-TO SCALE

ADDITIONAL INFORMATION: WELL ABANDONED

WELL ABANDONED: 1/8/92

FIELD WELL COMPLETION FORM

JOB NAME: EAKER, AFB

JOB NUMBER: 3K98 PROJECT MANAGER: GJG

LOGGED BY: LRE EDITED BY: BFN

WELL NAME: EUTW1108 DATE: 12/14/91

DRILLING COMPANY: A.W. POOL

EQUIPMENT: 7 1/2 INCH HOLLOW STEM AUGER DRILLER: V. BARRAZZO

INCH ROTARY WASH HOURS DRILLED: 0.75

GALLONS OF WATER USED DURING DRILLING: NONE GALLONS

METHOD OF DECONTAMINATION PRIOR TO DRILLING: STEAM (HIGH PRESSURE)

DEVELOPMENT SEE WELL DEVELOPMENT FORM

METHOD OF DEVELOPMENT:

YIELD:	GPM	TIME:	FROM	TO	DATE:

TOTAL WATER REMOVED DURING DEVELOPMENT: _____ GALLONS

DESCRIPTION OF TURBIDITY AT END OF DEVELOPMENT:

CLEAR SLIGHTLY CLOUDY

MOD. TURBID VERY MUDDY

ODOR OF WATER:

WATER DISCHARGED TO: GROUND SURFACE TANK TRUCK

STORM SEWERS STORAGE TANK

DRUMS OTHER _____

DEPTH TO WATER AFTER DEVELOPMENT: _____ FEET

- MATERIALS USED**
- 2.5 SACKS OF Silica Grade SAND
 - _____ SACKS OF _____ CEMENT
 - _____ GALLONS OF GROUT USED
 - _____ SACKS OF POWDERED BENTONITE
 - 50 POUNDS OF BENTONITE PELLETS
 - 8.00 FEET OF 2 INCH PVC BLANK CASING
 - 15.00 FEET OF 2 INCH PVC SLOTTED SCREEN

YARD CEMENTS _____

YARD CEMENT-SAND (RED MIX) USED _____

CONCRETE PUMPER USED? NO YES

NAME _____

WELL COVER USED: LOCKING STEEL COVER

CHRISTY BOX

OTHER _____

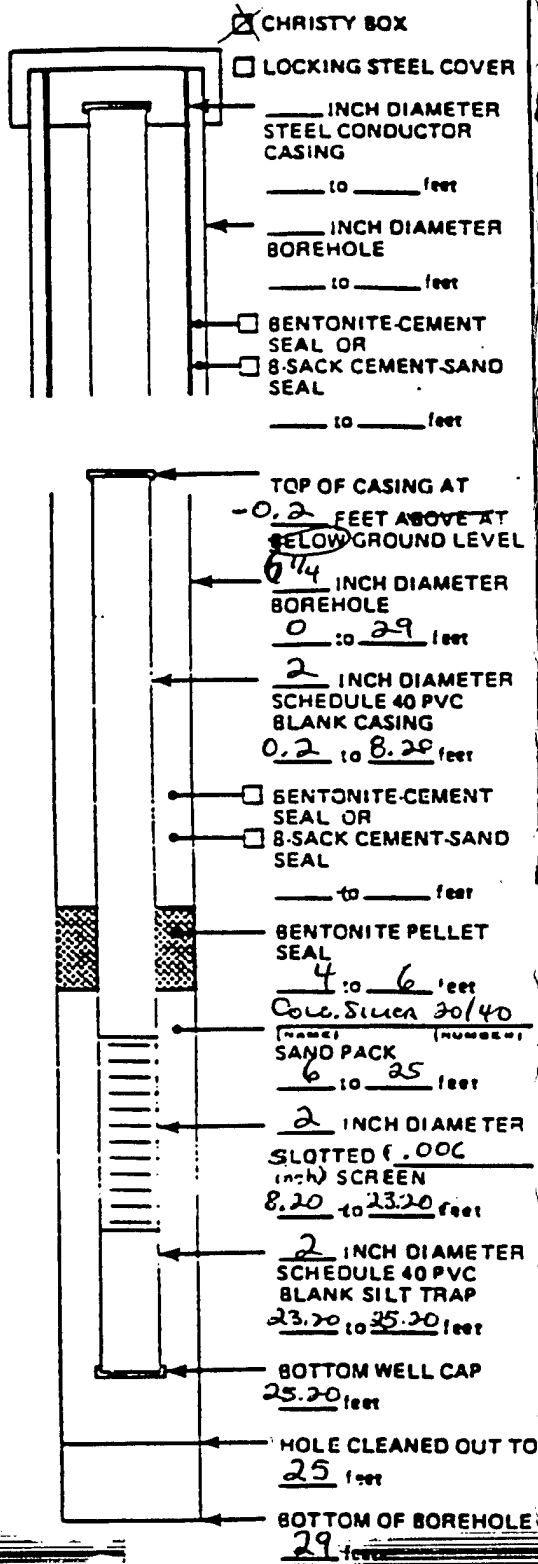

NOT TO SCALE

ADDITIONAL INFORMATION: Well

materials pulled on 12-18-91

Full recovery on well

Screen & riser. Borehole

backfilled with 250 sal

FIELD WELL COMPLETION FORM

JOB NAME: EAKER AFB

JOB NUMBER: 3K98 PROJECT MANAGER: GUG

LOGGED BY: LRE EDITED BY: BFN

WELL NAME: E11TW1109 DATE: 12/14/91

DRILLING COMPANY: A.W. POOL

EQUIPMENT: 6/4 INCH HOLLOW STEM AUGER DRILLER: V. BARRAZZO
 INCH ROTARY WASH HOURS DRILLED: 0.25
BFR

GALLONS OF WATER USED DURING DRILLING: NONE GALLONS

METHOD OF DECONTAMINATION PRIOR TO DRILLING: HIGH PRESSURE STEAM

DEVELOPMENT SEE WELL DEVELOPMENT FORM

METHOD OF DEVELOPMENT:

DEVELOPMENT BEGAN DATE:	TIME:	YIELD:	TIME:	DATE:
	FROM TO	GPM	FROM TO	

TOTAL WATER REMOVED DURING DEVELOPMENT: _____ GALLONS

DESCRIPTION OF TURBIDITY AT END OF DEVELOPMENT: CLEAR SLIGHTLY CLOUDY
 MOD. TURBID VERY MUDDY

ODOR OF WATER:

WATER DISCHARGED TO: GROUND SURFACE TANK TRUCK
 STORM SEWERS STORAGE TANK
 DRUMS OTHER _____

DEPTH TO WATER AFTER DEVELOPMENT: _____ FEET

MATERIALS USED

2.5 SACKS OF COLORADO SILICA 20/40 SAND

_____ SACKS OF _____ CEMENT

_____ GALLONS OF GROUT USED

50 SACKS OF POWDERED BENTONITE

8.00 POUNDS OF BENTONITE PELLETS

8.00 FEET OF 2 INCH PVC BLANK CASING

10.00 FEET OF 2 INCH PVC SLOTTED SCREEN

2.00 FEET OF _____

_____ YARD³ CEMENT-SAND (REDI-MIX) ORDERED

_____ YARD³ CEMENT-SAND (REDI-MIX) USED

CONCRETE PUMPER USED? NO YES

NAME _____

WELL COVER USED: LOCKING STEEL COVER
 CHRISTY BOX
 OTHER _____

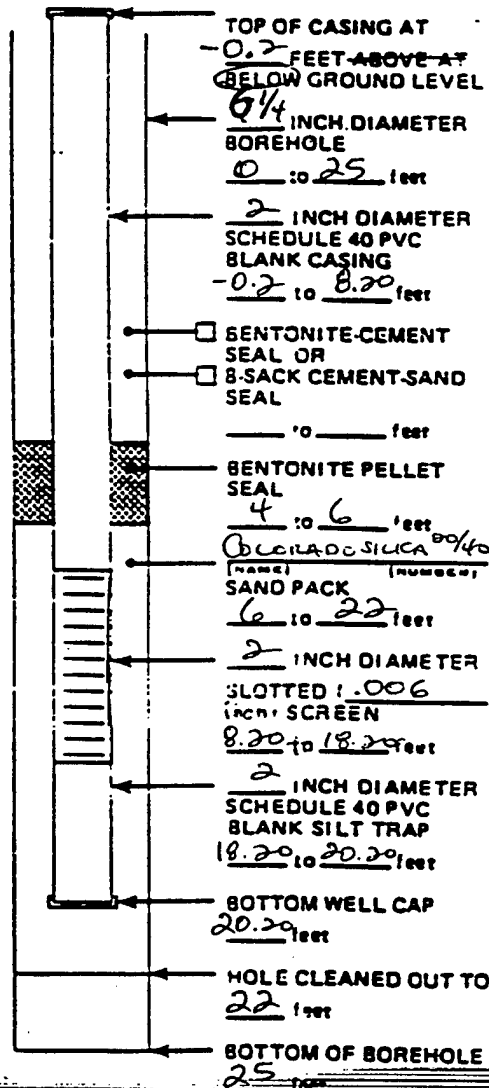
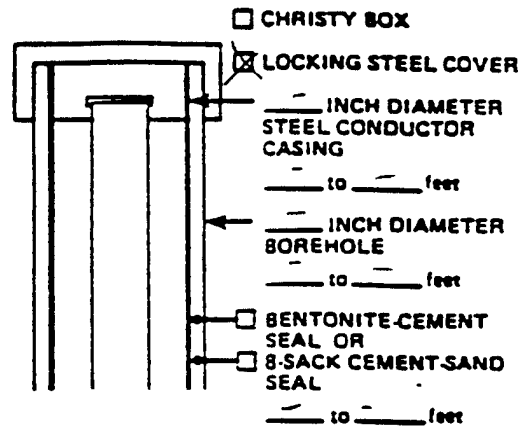

NOT TO SCALE

ADDITIONAL INFORMATION:

Bore Hole cased in 3'

FIELD WELL COMPLETION FORM

JOB NAME: FAIKEN
 JOB NUMBER: 3K9B PROJECT MANAGER: GVG
 LOGGED BY: LRE EDITED BY: BFN
 WELL NAME: E11TW1110 DATE: 12/14/91
 DRILLING COMPANY: A W POOL
 EQUIPMENT: 6 1/4 INCH HOLLOW STEM AUGER DRILLER: V. BARRAZA
 INCH ROTARY WASH HOURS DRILLED: 55

GALLONS OF WATER USED DURING DRILLING: NONE GALLONS

METHOD OF DECONTAMINATION PRIOR TO DRILLING: HIGH PRESSURE STEAM

DEVELOPMENT SEE WELL DEVELOPMENT FORM

METHOD OF DEVELOPMENT:

DEVELOPMENT BEGAN DATE:	TIME:	YIELD:	DATE:
		GPM	
	FROM TO		
		GPM	
	FROM TO		
		GPM	
	FROM TO		
		GPM	
	FROM TO		

TOTAL WATER REMOVED DURING DEVELOPMENT: GALLONS

DESCRIPTION OF TURBIDITY AT END OF DEVELOPMENT: CLEAR SLIGHTLY CLOUDY
 MOD. TURBID VERY MUDDY

ODOR OF WATER:

WATER DISCHARGED TO: GROUND SURFACE TANK TRUCK
 STORM SEWERS STORAGE TANK
 DRUMS OTHER

DEPTH TO WATER AFTER DEVELOPMENT: FEET

MATERIALS USED

- 2.5 SACKS OF silica Grade SAND
- SACKS OF CEMENT
- ~5 GALLONS OF GROUT USED (CEMENT/BENTONITE)
- SACKS OF POWDERED BENTONITE
- 50 POUNDS OF BENTONITE PELLETS
- 8.00 FEET OF 2 INCH PVC BLANK CASING
- 10.00 FEET OF 2 INCH PVC SLOTTED SCREEN
- 2.00 FEET OF

YARD CEMENT-SAND (REG. MIX) USED

YARD CEMENT-SAND (RED-MIX) USED

CONCRETE PUMPER USED? NO YES

NAME

WELL COVER USED: LOCKING STEEL COVER
 CHRISTY BOX
 OTHER

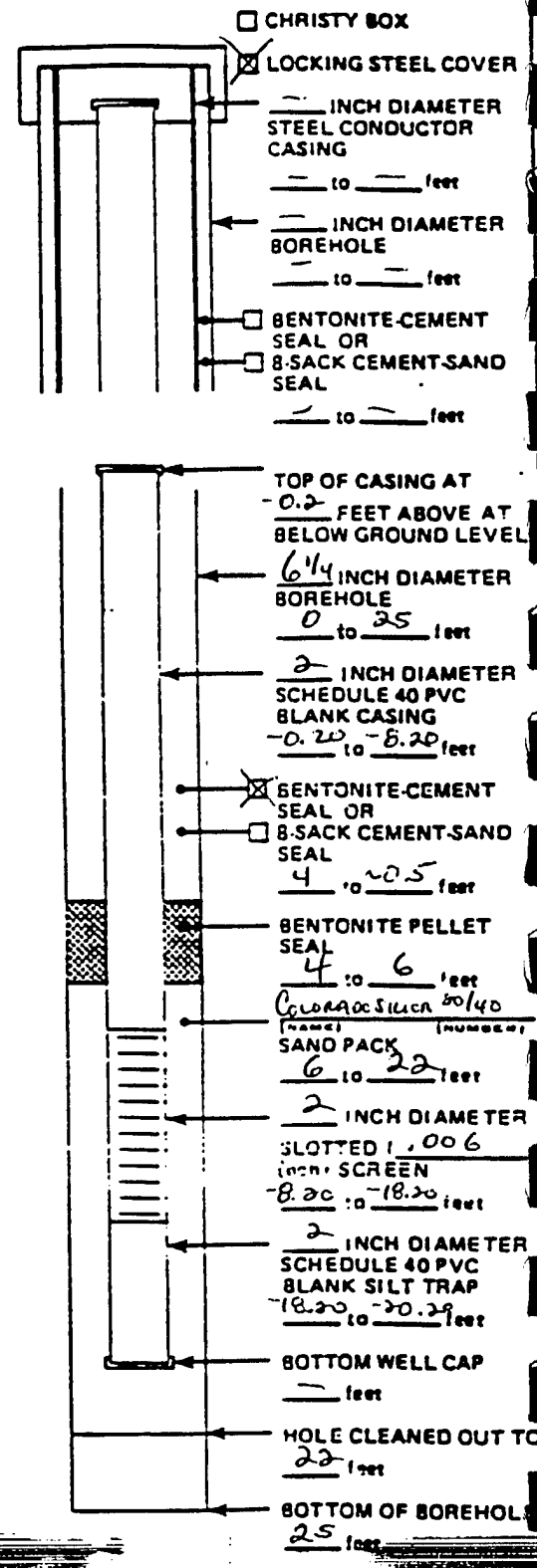

NOT TO SCALE

ADDITIONAL INFORMATION:

FIELD WELL COMPLETION FORM

JOB NAME: EAKER AFB

JOB NUMBER: 3K98 PROJECT MANAGER: GVG

LOGGED BY: BFK EDITED BY: JSB

WELL NAME: E11TW111 DATE: 12-15-91

DRILLING COMPANY: POOL

EQUIPMENT: 6 1/4 INCH HOLLOW STEM AUGER DRILLER: V. BOUTZEG
 INCH ROTARY WASH HOURS DRILLED: 0.42

GALLONS OF WATER USED DURING DRILLING: NONE GALLONS

METHOD OF DECONTAMINATION PRIOR TO DRILLING: HIGH PRESSURE STEAM

DEVELOPMENT SEE WELL DEVELOPMENT FORM

METHOD OF DEVELOPMENT:

DEVELOPMENT BEGAN DATE:	TIME:		DATE:
YIELD:	GPM	TIME: FROM TO	DATE:

TOTAL WATER REMOVED DURING DEVELOPMENT: _____ GALLONS

DESCRIPTION OF TURBIDITY AT END OF DEVELOPMENT: CLEAR SLIGHTLY CLOUDY
 MOD. TURBID VERY MUDDY

ODOR OF WATER:

WATER DISCHARGED TO: GROUND SURFACE TANK TRUCK
 STORM SEWERS STORAGE TANK
 DRUMS OTHER _____

DEPTH TO WATER AFTER DEVELOPMENT: _____ FEET

MATERIALS USED

- 2.5 SACKS OF Silica Grade SAND
- _____ SACKS OF _____ CEMENT
- 25 GALLONS OF GROUT USED (CEMENT/BENTONITE MIX)
- _____ SACKS OF POWDERED BENTONITE
- 25 POUNDS OF BENTONITE PELLETS
- 8 FEET OF 2 INCH PVC BLANK CASING
- 10 FEET OF 2 INCH PVC SLOTTED SCREEN
- 2 _____

YARD _____ (CEMENT MIX) ORDERED

YARD CEMENT-SAND MIX USED

CONCRETE PUMPER USED? NO YES

NAME _____

WELL COVER USED: LOCKING STEEL COVER
 CHRISTY BOX
 OTHER _____

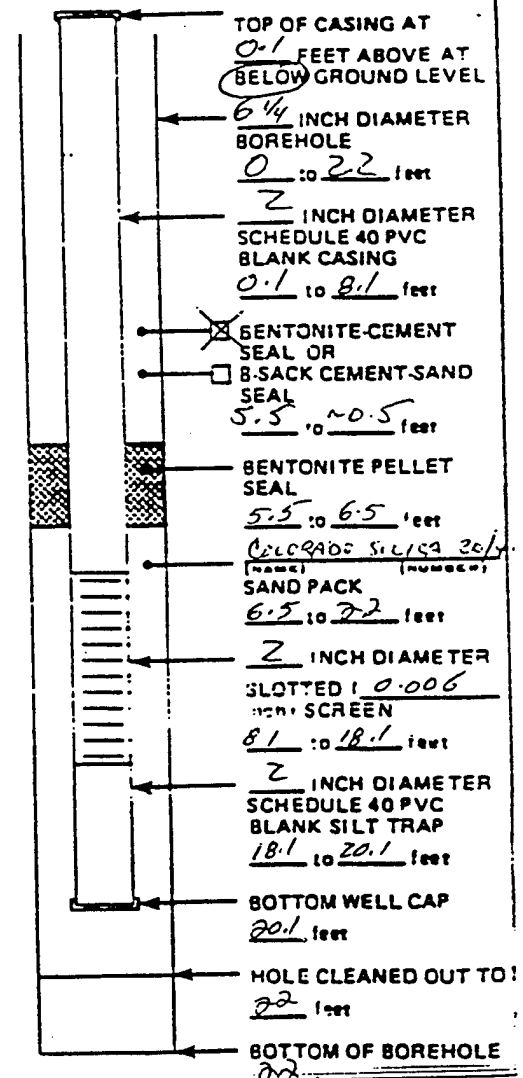
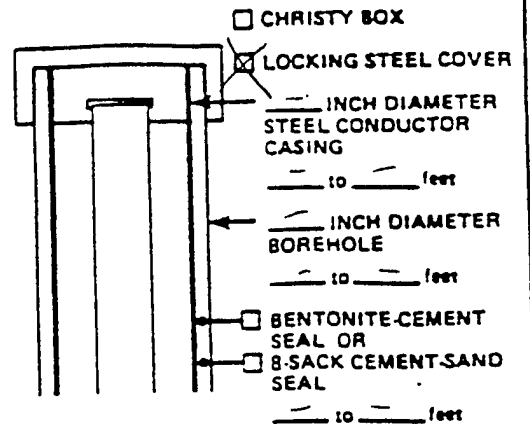

NOT TO SCALE

ADDITIONAL INFORMATION: _____

FIELD WELL COMPLETION FORM

JOB NAME: EAKER AFB

JOB NUMBER: 3K98 PROJECT MANAGER: GUG

LOGGED BY: BFKI EDITED BY: JSB

WELL NAME: E111112 DATE: 12-15-91

DRILLING COMPANY: Pool Drilling

EQUIPMENT: 6 1/4 INCH HOLLOW STEM AUGER DRILLER: V. BURAZZA
 INCH ROTARY WASH HOURS DRILLED: 1.25

GALLONS OF WATER USED DURING DRILLING: NONE GALLONS

METHOD OF DECONTAMINATION PRIOR TO DRILLING: Steam cleaned

DEVELOPMENT SEE WELL DEVELOPMENT FORM

METHOD OF DEVELOPMENT:

DEVELOPMENT BEGAN DATE:	TIME:	YIELD:	DATE:
		GPM	
	FROM TO		
		GPM	
	FROM TO		
		GPM	
	FROM TO		
		GPM	
	FROM TO		

TOTAL WATER REMOVED DURING DEVELOPMENT: _____ GALLONS

DESCRIPTION OF TURBIDITY AT END OF DEVELOPMENT: CLEAR SLIGHTLY CLOUDY
 MOD. TURBID VERY MUDDY

ODOR OF WATER:

WATER DISCHARGED TO: GROUND SURFACE TANK TRUCK
 STORM SEWERS STORAGE TANK
 DRUMS OTHER _____

DEPTH TO WATER AFTER DEVELOPMENT: _____ FEET

MATERIALS USED

- 3.5 SACKS OF SILICA GRADE SAND
- _____ SACKS OF _____ CEMENT
- _____ GALLONS OF GROUT USED
- _____ SACKS OF POWDERED BENTONITE
- 25 POUNDS OF BENTONITE PELLETS
- 8 FEET OF 2 INCH PVC BLANK CASING
- 15 FEET OF 2 INCH PVC SLOTTED SCREEN

_____ YARD³ CEMENT-SAND (REDI-MIX) ORDERED

_____ YARD³ CEMENT-SAND (REDI-MIX) USED

CONCRETE PUMPER USED? NO YES

NAME _____

WELL COVER USED: LOCKING STEEL COVER
 CHRISTY BOX
 OTHER _____

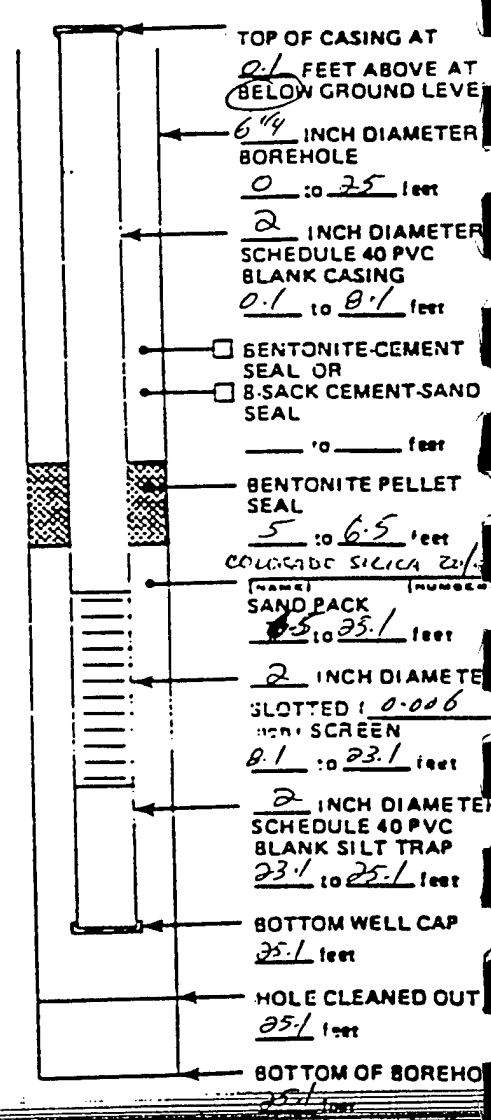
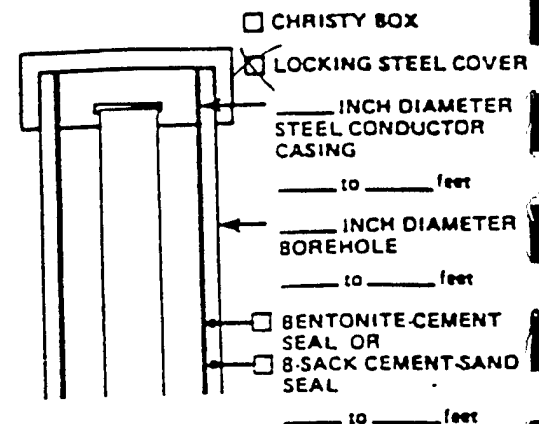

NOT TO SCALE

ADDITIONAL INFORMATION: Material was pulled & grouted to surface, on 12/15/91. Full recovery of well screen & riser.

FIELD WELL COMPLETION FORM

JOB NAME: EAKER APB

JOB NUMBER: 3K98 PROJECT MANAGER: GVC

LOGGED BY: LRE EDITED BY: BJN

WELL NAME: E11TW1113 DATE: 12/15/91

DRILLING COMPANY: AWPOOL

EQUIPMENT: 6 1/4 INCH HOLLOW STEM AUGER DRILLER: V. BARAAZA
 INCH ROTARY WASH HOURS DRILLED: 1

GALLONS OF WATER USED DURING DRILLING: 30 GALLONS

METHOD OF DECONTAMINATION PRIOR TO DRILLING: HIGH PRESSURE STEAM

DEVELOPMENT SEE WELL DEVELOPMENT FORM

METHOD OF DEVELOPMENT:

YIELD:	GPM	TIME:	FROM	TO	DATE:

TOTAL WATER REMOVED DURING DEVELOPMENT: _____ GALLONS

DESCRIPTION OF TURBIDITY AT END OF DEVELOPMENT: CLEAR SLIGHTLY CLOUDY
 MOD. TURBID VERY MUDDY

ODOR OF WATER: _____

WATER DISCHARGED TO: GROUND SURFACE TANK TRUCK
 STORM SEWERS STORAGE TANK
 DRUMS OTHER _____

DEPTH TO WATER AFTER DEVELOPMENT: _____ FEET

MATERIALS USED

2 SACKS OF Colorado 20/40 SAND

- SACKS OF _____ CEMENT

- GALLONS OF GROUT USED

- SACKS OF POWDERED BENTONITE

50 POUNDS OF BENTONITE PELLETS

8.2 FEET OF 2 INCH PVC BLANK CASING

14.9 FEET OF 2 INCH PVC SLOTTED SCREEN

YARD CEMENT-SAND (RED-MIX) ORDERED

YARD CEMENT-SAND (RED-MIX) USED

CONCRETE PUMPER USED? NO YES

NAME _____

WELL COVER USED: LOCKING STEEL COVER (NONE USED JSB 3/31/92)
 CHRISTY BOX
 OTHER _____

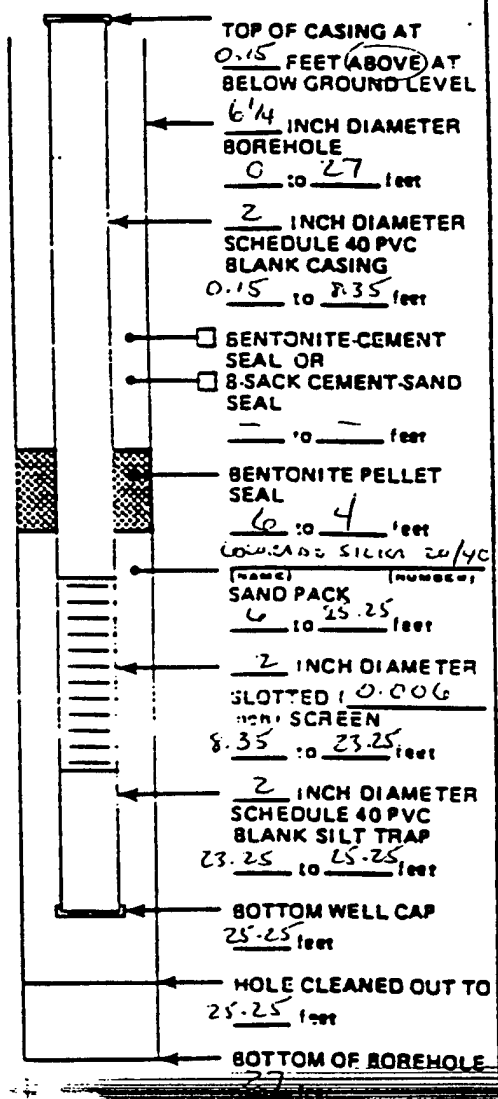
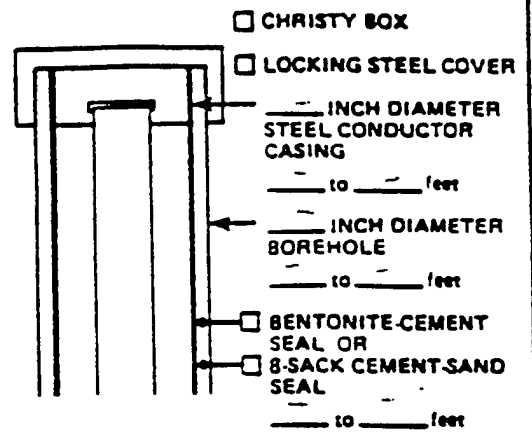

NOT TO SCALE

ADDITIONAL INFORMATION: _____

Materials pulled; well grouted to the surface

12/18/91 JSB

FIELD WELL COMPLETION FORM

JOB NAME: EAKER AFB

JOB NUMBER: 3K98 PROJECT MANAGER: GUG

LOGGED BY: URE EDITED BY: RFN

WELL NAME: E11TW1114 DATE: 12/16/91

DRILLING COMPANY: A.W POOL

EQUIPMENT: 6 1/4 INCH HOLLOW STEM AUGER DRILLER: J. BAYLARA
 INCH ROTARY WASH HOURS DRILLED: 1

GALLONS OF WATER USED DURING DRILLING: NONE GALLONS

METHOD OF DECONTAMINATION PRIOR TO DRILLING: STEAM CLEANED

DEVELOPMENT SEE WELL DEVELOPMENT FORM

METHOD OF DEVELOPMENT:

DEVELOPMENT BEGAN DATE:	TIME:	YIELD:	DATE:
	FROM TO	GPM	
	FROM TO	GPM	
	FROM TO	GPM	
	FROM TO	GPM	

TOTAL WATER REMOVED DURING DEVELOPMENT: _____ GALLONS

DESCRIPTION OF TURBIDITY AT END OF DEVELOPMENT: CLEAR SLIGHTLY CLOUDY
 MOD. TURBID VERY MUDDY

ODOR OF WATER:

WATER DISCHARGED TO: GROUND SURFACE TANK TRUCK
 STORM SEWERS STORAGE TANK
 DRUMS OTHER _____

DEPTH TO WATER AFTER DEVELOPMENT: _____ FEET

MATERIALS USED

2 SACKS OF Colorado Silica 20/40 SAND

_____ SACKS OF _____ CEMENT

~2 GALLONS OF GROUT USED (CEMENT/BENTONITE BENTONITE PELLET SEAL)

_____ SACKS OF POWDERED BENTONITE

180 POUNDS OF BENTONITE PELLETS

6.1 FEET OF 2 INCH PVC BLANK CASING

10.2 FEET OF 2 INCH PVC SLOTTED SCREEN

2.00'

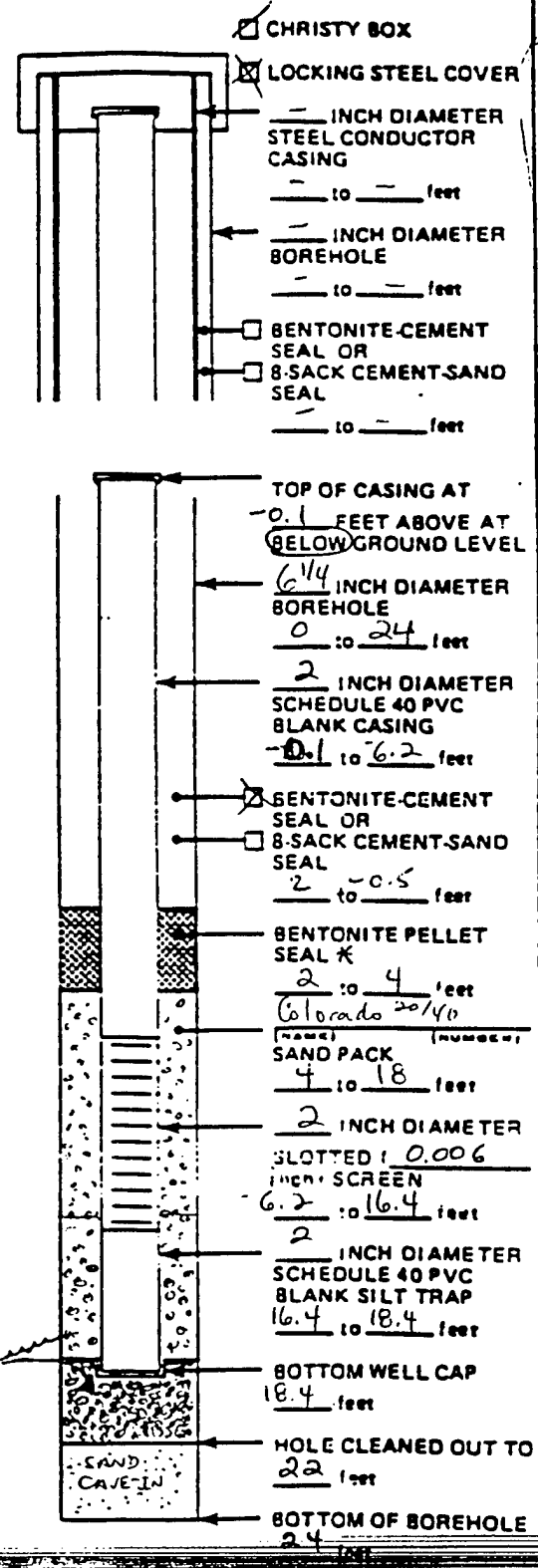

_____ YARD³ CEMENT-SAND (REDI-MIX) ORDERED

_____ YARD³ CEMENT-SAND (REDI-MIX) USED

CONCRETE PUMPER USED? NO YES

NAME _____

WELL COVER USED: LOCKING STEEL COVER
 CHRISTY BOX
 OTHER _____

NOT TO SCALE

ADDITIONAL INFORMATION: SEAL From 18'-22'

FIELD WELL COMPLETION FORM

JOB NAME: EAKER AFB

JOB NUMBER: 3198 PROJECT MANAGER: GUG

LOGGED BY: URE EDITED BY: BFN

WELL NAME: ELLTWIIS DATE: 12/16/91

DRILLING COMPANY: A.W. POOL

EQUIPMENT: 6 1/4 INCH HOLLOW STEM AUGER DRILLER: V. BARRAZA
 INCH ROTARY WASH HOURS DRILLED: 1.0

GALLONS OF WATER USED DURING DRILLING: NONE GALLONS

METHOD OF DECONTAMINATION PRIOR TO DRILLING: HIGH PRESSURE STEAM

DEVELOPMENT SEE DEVELOPMENT FORM

METHOD OF DEVELOPMENT:

DEVELOPMENT BEGAN DATE: _____ TIME: _____

YIELD:	GPM	TIME: FROM	TO	DATE:

TOTAL WATER REMOVED DURING DEVELOPMENT: _____ GALLONS

DESCRIPTION OF TURBIDITY AT END OF DEVELOPMENT: CLEAR SLIGHTLY CLOUDY
 MOD. TURBID VERY MUDDY

ODOR OF WATER:

WATER DISCHARGED TO: GROUND SURFACE TANK TRUCK
 STORM SEWERS STORAGE TANK
 DRUMS OTHER _____

DEPTH TO WATER AFTER DEVELOPMENT: _____ FEET

MATERIALS USED

- _____ SACKS OF Colorado Silica 20/40 SAND
- _____ SACKS OF _____ CEMENT
- 2 GALLONS OF GROUT USED (CEMENT/BENTONITE)
- _____ SACKS OF POWDERED BENTONITE
- 25 POUNDS OF BENTONITE PELLETS
- 6.15 FEET OF 2 INCH PVC BLANK CASING
- 10.1 FEET OF 2 INCH PVC SLOTTED SCREEN

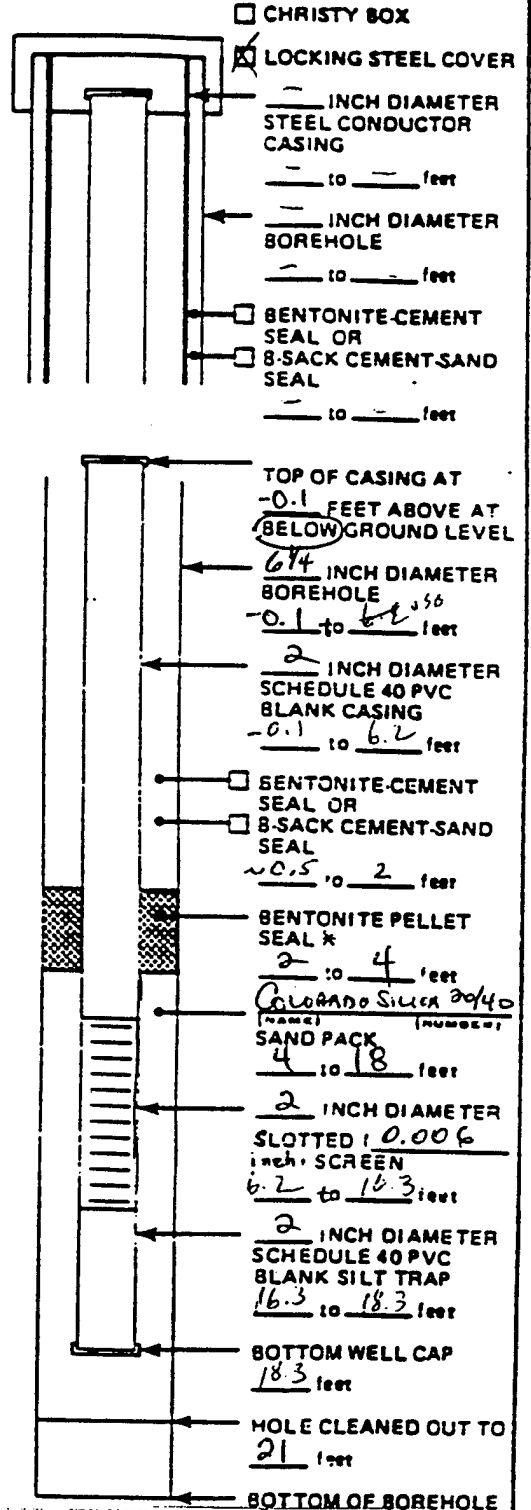

_____ YARD³ CEMENT-SAND (REDI-MIX) ORDERED

_____ YARD³ CEMENT-SAND (REDI-MIX) USED

CONCRETE PUMPER USED? NO YES

NAME _____

WELL COVER USED: LOCKING STEEL COVER
 CHRISTY BOX
 OTHER _____

NOT TO SCALE

ADDITIONAL INFORMATION: PELLETS 18-21 TO SEAL OFF LOWER WATER ZONE

JOB NAME: 1 EAKER AFB
 JOB NUMBER: 3K98 PROJECT MANAGER: GNV
 LOGGED BY: LRE EDITED BY: BNJ
 WELL NAME: EHFW16 TWILL DATE: 12/16/91

DRILLING COMPANY:
 EQUIPMENT: 6 1/4 INCH HOLLOW STEM AUGER DRILLER: V. Bara
 INCH ROTARY WASH HOURS DRILLED: 0.5

GALLONS OF WATER USED DURING DRILLING: _____ GALLONS

METHOD OF DECONTAMINATION PRIOR TO DRILLING: HIGH PRESSURE STEAM

DEVELOPMENT

METHOD OF DEVELOPMENT:

YIELD:	GPM	TIME:	FROM	TO	DATE:
YIELD:	GPM	TIME:	FROM	TO	DATE:
YIELD:	GPM	TIME:	FROM	TO	DATE:
YIELD:	GPM	TIME:	FROM	TO	DATE:

TOTAL WATER REMOVED DURING DEVELOPMENT: _____ GALLONS

DESCRIPTION OF TURBIDITY AT END OF DEVELOPMENT: CLEAR SLIGHTLY CLOUDY
 MOD. TURBID VERY MUDDY

ODOR OF WATER:
 WATER DISCHARGED TO: GROUND SURFACE TANK TRUCK
 STORM SEWERS STORAGE TANK
 DRUMS OTHER _____

DEPTH TO WATER AFTER DEVELOPMENT: _____ FEET

MATERIALS USED

- 3 SACKS OF 20/40 COLORADO SILICA SAND
- _____ SACKS OF _____ CEMENT
- 4 GALLONS OF GROUT USED (CEMENT/BENTONITE MIX)
- _____ SACKS OF POWDERED BENTONITE
- 25 POUNDS OF BENTONITE PELLETS
- 10 FEET OF 2 INCH PVC BLANK CASING
- 10 FEET OF _____ INCH _____ _____ _____ 2.3' cut off

YARD CEMENT-SAND (REDI-MIX) ORDERED

_____ YARD CEMENT-SAND (REDI-MIX) USED

CONCRETE PUMPER USED? NO YES

NAME _____

WELL COVER USED: LOCKING STEEL COVER
 CHRISTY BOX
 OTHER _____

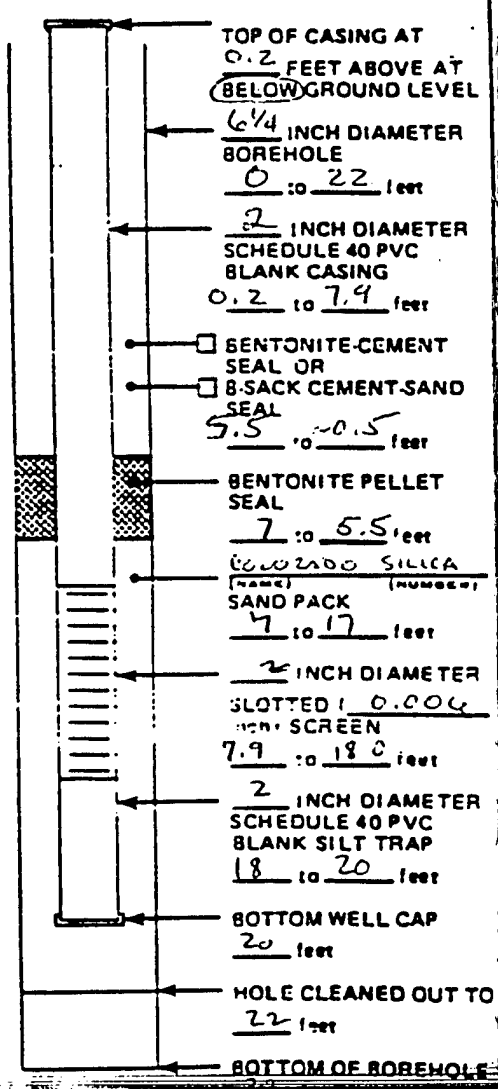
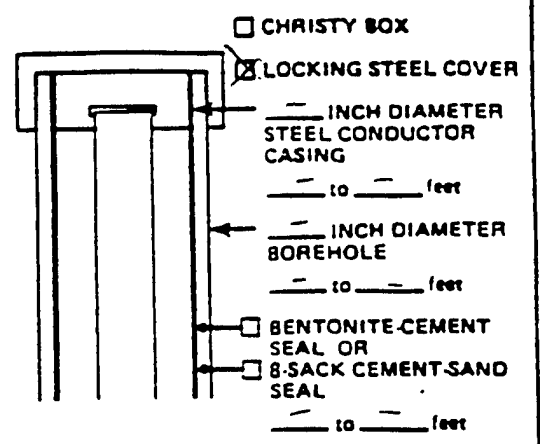

NOT TO SCALE

ADDITIONAL INFORMATION: _____
 Screen was originally set from 9.4-19.5 feet well was pulled up 1.5' and completed 12/17/91

FIELD WELL COMPLETION FORM

JOB NAME: EAKER AFB

JOB NUMBER: 3K98 PROJECT MANAGER: GUG

LOGGED BY: LRE EDITED BY: BFN

WELL NAME: E11-TW1119 DATE: 12/17/91

DRILLING COMPANY: AW POOL

EQUIPMENT: 6 1/4 INCH HOLLOW STEM AUGER DRILLER: V. BARRAZA
 INCH ROTARY WASH HOURS DRILLED: 1

GALLONS OF WATER USED DURING DRILLING: NONE GALLONS

METHOD OF DECONTAMINATION PRIOR TO DRILLING: PRESSURE STEAM

DEVELOPMENT SEE WELL DEVELOPMENT FORM

METHOD OF DEVELOPMENT:

DEVELOPMENT BEGAN DATE: _____ TIME: _____

YIELD:	GPM	TIME:	DATE:
		FROM TO	

TOTAL WATER REMOVED DURING DEVELOPMENT: _____ GALLONS

DESCRIPTION OF TURBIDITY AT END OF DEVELOPMENT: CLEAR SLIGHTLY CLOUDY
 MOD. TURBID VERY MUDDY

ODOR OF WATER:

WATER DISCHARGED TO: GROUND SURFACE TANK TRUCK
 STORM SEWERS STORAGE TANK
 DRUMS OTHER _____

DEPTH TO WATER AFTER DEVELOPMENT: _____ FEET

MATERIALS USED

- 3 SACKS OF COLORADO SILICA 20/40 SAND
- _____ SACKS OF _____ CEMENT
- 21 GALLONS OF GROUT USED (CEMENT/BENTONITE MIX)
- _____ SACKS OF POWDERED BENTONITE
- 25 POUNDS OF BENTONITE PELLETS
- 4.8 FEET OF 2 INCH PVC BLANK CASING
- 10.0 FEET OF 2 INCH PVC SLOTTED SCREEN

BENTONITE SEAL 17-18'

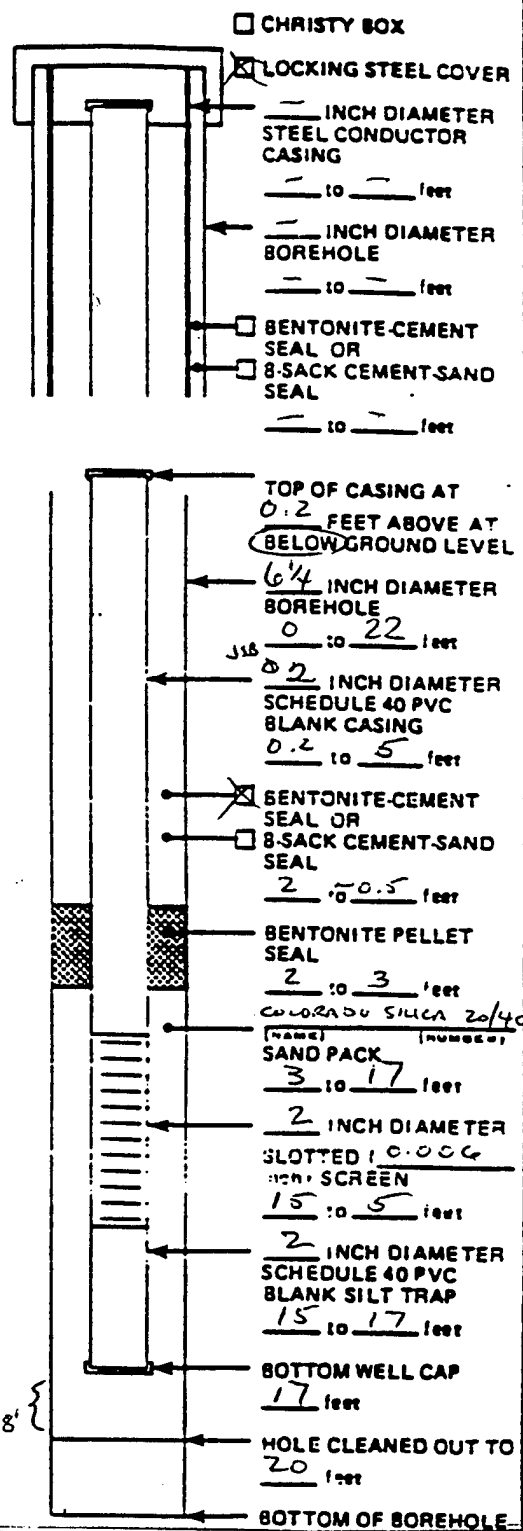

_____ YARD³ CEMENT-SAND (REDI-MIX) ORDERED

_____ YARD³ CEMENT-SAND (REDI-MIX) USED

CONCRETE PUMPER USED? NO YES

NAME _____

WELL COVER USED: LOCKING STEEL COVER
 CHRISTY BOX
 OTHER _____

NOT TO SCALE

ADDITIONAL INFORMATION: _____

FIELD WELL COMPLETION FORM

JOB NAME: EAKER AFB BX Shopette
 JOB NUMBER: 3K98 PROJECT MANAGER: G/G
 LOGGED BY: JSB EDITED BY: BFN
 WELL NAME: TW1120 DATE: 1-7-92
 DRILLING COMPANY: AW POOL
 EQUIPMENT: 6/4 INCH HOLLOW STEM AUGER DRILLER: V. SARAZZA
 INCH ROTARY WASH HOURS DRILLED: .88

GALLONS OF WATER USED DURING DRILLING: NONE GALLONS

METHOD OF DECONTAMINATION PRIOR TO DRILLING: PRESSURE STEAM

DEVELOPMENT SEE WELL DEVELOPMENT FORM

METHOD OF DEVELOPMENT:

DEVELOPMENT BEGAN DATE:	TIME:	YIELD:	TIME:	DATE:
		GPM	FROM TO	

TOTAL WATER REMOVED DURING DEVELOPMENT: _____ GALLONS

DESCRIPTION OF TURBIDITY AT END OF DEVELOPMENT:

CLEAR SLIGHTLY CLOUDY
 MOD. TURBID VERY MUDDY

ODOR OF WATER:

WATER DISCHARGED TO: GROUND SURFACE TANK TRUCK
 STORM SEWERS STORAGE TANK
 DRUMS OTHER _____

DEPTH TO WATER AFTER DEVELOPMENT: _____ FEET

MATERIALS USED

2 100# SACKS OF COLORADO SILICA 20/40 SAND
 _____ SACKS OF PORTLAND TYPE II CEMENT
 _____ GALLONS OF GROUT USED
 _____ SACKS OF POWDERED BENTONITE
50 POUNDS OF BENTONITE PELLETS
20 FEET OF 2 INCH PVC BLANK CASING
10 FEET OF 2 INCH PVC SLOTTED SCREEN
2 FEET OF 2 INCH PVC SUMP

_____ YARD³ CEMENT-SAND (REDI-MIX) ORDERED
 _____ YARD³ CEMENT-SAND (REDI-MIX) USED
 CONCRETE PUMPER USED? NO YES
 NAME _____
 WELL COVER USED: LOCKING STEEL COVER
 CHRISTY BOX
 OTHER _____

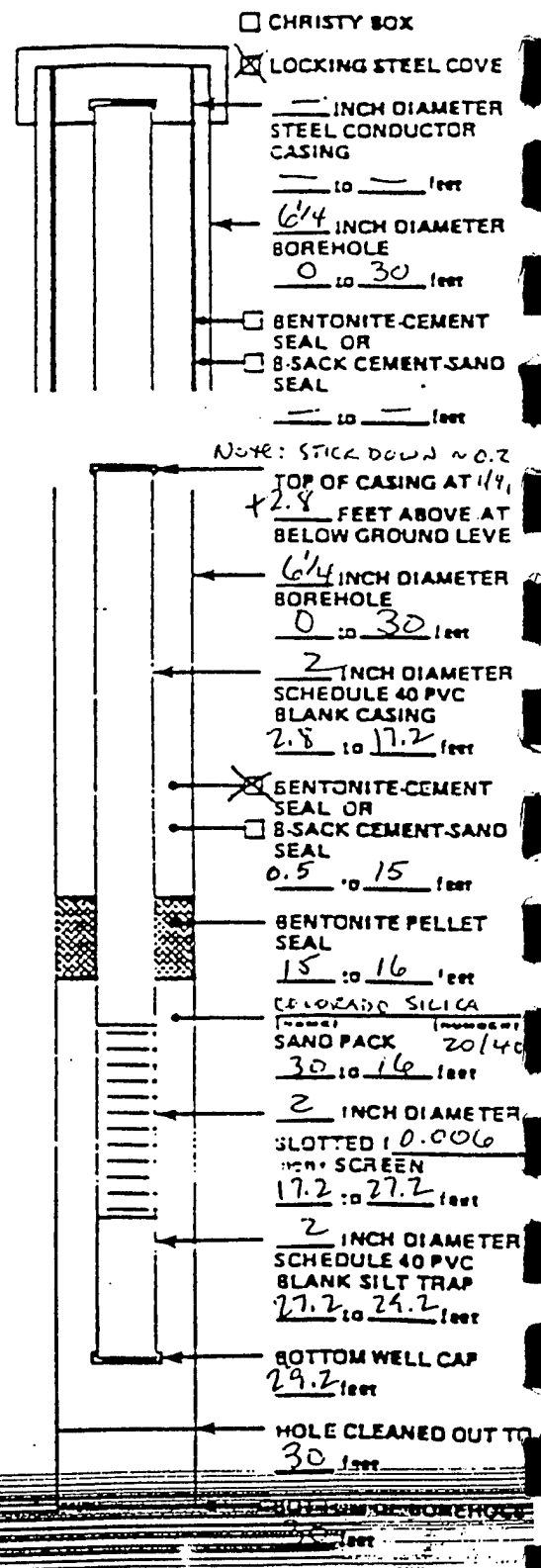

NOT TO SCALE

ADDITIONAL INFORMATION:
WELL PAD WAS CONSTRUCTED
1/9/92 - CUT OFF ~30' OF
2" SUMP PIPE, COMPLETED WELL
AS PER PLAN



FIELD WELL COMPLETION FORM

JOB NAME: Kaher AFB

JOB NUMBER: 0114 PROJECT MANAGER: A JENNINS

LOGGED BY: RPH EDITED BY: H Ellis

WELL NAME: MW1121 DATE: 4/8/95

DRILLING COMPANY: Tri-State Drilling

EQUIPMENT: 2 1/2 INCH HOLLOW STEM AUGER 1 hr of logs
 INCH ROTARY WASH HOURS DRILLED: _____

GALLONS OF WATER USED DURING DRILLING: NA GALLONS

METHOD OF DECONTAMINATION PRIOR TO DRILLING: Steam cleaner

DEVELOPMENT SEE WELL DEVELOPMENT FORM

METHOD OF DEVELOPMENT: _____

DEVELOPMENT BEGAN DATE:		TIME:		DATE:
YIELD:	GPM	TIME: FROM	TO	DATE:
YIELD:	GPM	TIME: FROM	TO	DATE:
YIELD:	GPM	TIME: FROM	TO	DATE:
YIELD:	GPM	TIME: FROM	TO	DATE:

TOTAL WATER REMOVED DURING DEVELOPMENT: _____ GALLONS

DESCRIPTION OF TURBIDITY AT END OF DEVELOPMENT: CLEAR SLIGHTLY CLOUDY MOD. TURBID VERY MUDDY

ODOR OF WATER: _____

WATER DISCHARGED TO: GROUND SURFACE TANK TRUCK STORM SEWERS STORAGE TANK DRUMS OTHER _____

DEPTH TO WATER AFTER DEVELOPMENT: _____ FEET

MATERIALS USED

11 SACKS OF 50lb 20/40 mine SAND

_____ SACKS OF _____ CEMENT

_____ GALLONS OF GROUT USED

75 SACKS OF POWDERED BENTONITE

1.8(4) 4.95 POUNDS OF BENTONITE PELLETS

10.0 FEET OF 2 INCH PVC BLANK CASING

2.0 FEET OF 2 INCH PVC SLOTTED SCREEN 5.5

2.0 feet of 2 inch 3.5 slot trap

_____ YARD³ CEMENT-SAND (REDI-MIX) ORDERED

_____ YARD³ CEMENT-SAND (REDI-MIX) USED

CONCRETE PUMPER USED? NO YES

NAME _____

WELL COVER USED: LOCKING STEEL COVER CHRISTY BOX OTHER _____

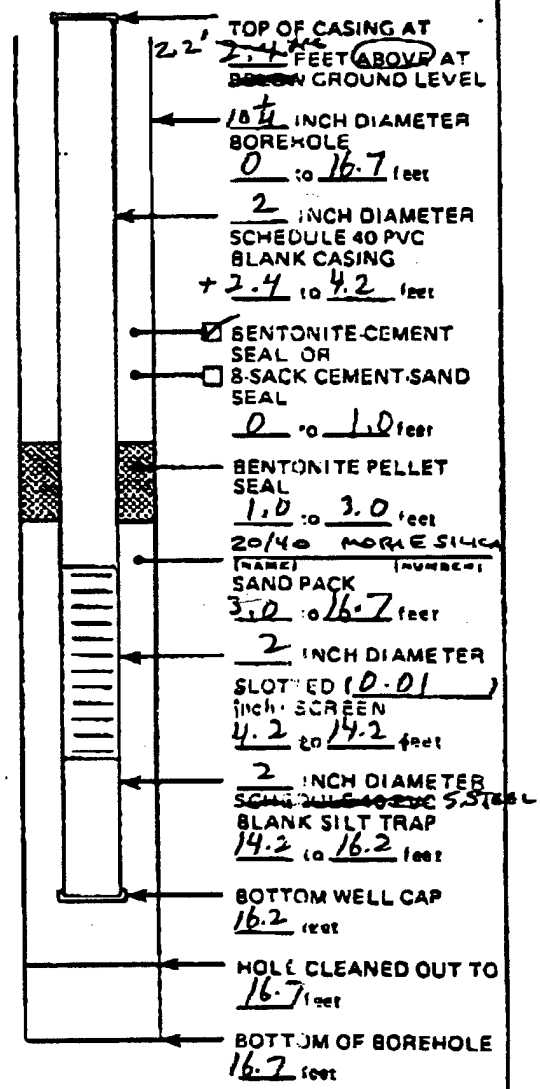
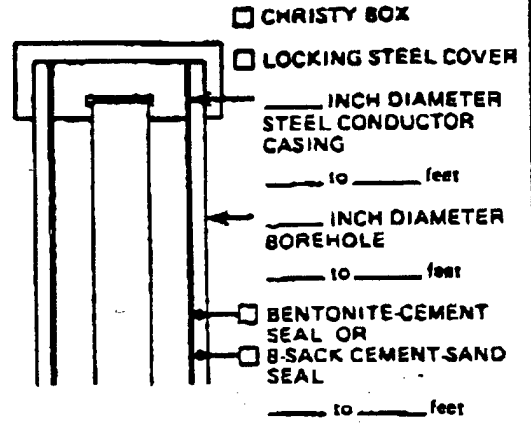

NOT TO SCALE

ADDITIONAL INFORMATION: _____



FIELD WELL COMPLETION FORM

JOB NAME: Kahn AFB
 JOB NUMBER: 0114 PROJECT MANAGER: A Jenkins
 LOGGED BY: BDH EDITED BY: JR Ellis
 WELL NAME: MW1122 DATE: 4/7/95

DRILLING COMPANY: Tri-state Drilling
 EQUIPMENT: 7 1/4 INCH HOLLOW STEM AUGER 10 1/2 RD. DRILLED BY: Joe Legger
 INCH ROTARY WASH HOURS DRILLED:

GALLONS OF WATER USED DURING DRILLING: NA GALLONS

METHOD OF DECONTAMINATION PRIOR TO DRILLING: Joan Jones

DEVELOPMENT SEE WELL DEVELOPMENT FORM

METHOD OF DEVELOPMENT:

DEVELOPMENT BEGAN DATE:	TIME:	DATE:
YIELD: GPM	TIME: FROM TO	DATE:
YIELD: GPM	TIME: FROM TO	DATE:
YIELD: GPM	TIME: FROM TO	DATE:
YIELD: GPM	TIME: FROM TO	DATE:

TOTAL WATER REMOVED DURING DEVELOPMENT: _____ GALLONS

DESCRIPTION OF TURBIDITY AT END OF DEVELOPMENT: CLEAR SLIGHTLY CLOUDY
 MOD. TURBID VERY MUDDY

ODOR OF WATER:

WATER DISCHARGED TO: GROUND SURFACE TANK TRUCK
 STORM SEWERS STORAGE TANK
 DRUMS OTHER

DEPTH TO WATER AFTER DEVELOPMENT: _____ FEET

MATERIALS USED

- 11.5 SACKS OF 25 50 lb bag 20/40 Marie SAND
- _____ SACKS OF _____ CEMENT
- _____ GALLONS OF GROUT USED
- _____ SACKS OF POWDERED BENTONITE
- 75 POUNDS OF BENTONITE PELLETS
- 8.3 FEET OF 2 INCH PVC BLANK CASING
- 10.0 FEET OF 2 INCH 3.5 SLOTTED SCREEN
- 2.2 FEET OF 2 inch S.S. silt trap
- _____ YARD³ CEMENT-SAND (REDI-MIX) ORDERED
- _____ YARD³ CEMENT-SAND (REDI-MIX) USED

CONCRETE PUMPER USED? NO YES

NAME _____

WELL COVER USED: LOCKING STEEL COVER
 CHRISTY BOX
 OTHER _____

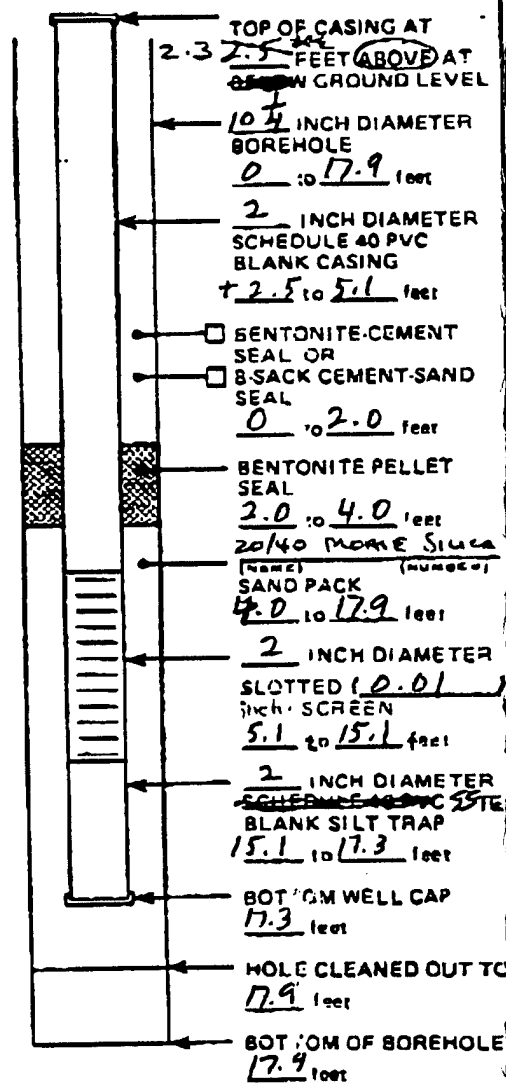
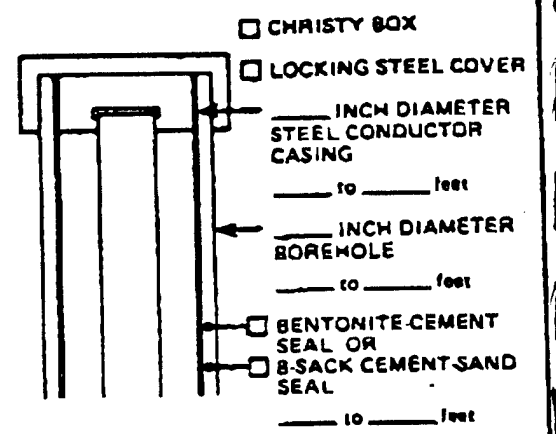

NOT TO SCALE

ADDITIONAL INFORMATION: _____

FIELD WELL COMPLETION FORM

JOB NAME: Eaker AFB
 JOB NUMBER: 0114 PROJECT MANAGER: Allan Jenkins
 LOGGED BY: G. Miller EDITED BY: JL Ellis
 WELL NAME: MW1123 DATE: 8/11/95
 DRILLING COMPANY: Tri state Testing Services
 EQUIPMENT: 10 INCH HOLLOW STEM AUGER DRILLER: J. Crawford
 INCH ROTARY WASH HOURS DRILLED:

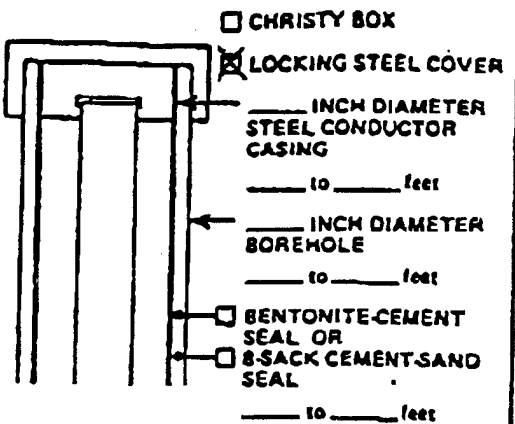

GALLONS OF WATER USED DURING DRILLING: 7 GALLONS *for by decision*

METHOD OF DECONTAMINATION PRIOR TO DRILLING: Steam cleaning
 DEVELOPMENT See Well Development Form

METHOD OF DEVELOPMENT:

YIELD:	GPM	TIME: FROM	TO	DATE:

TOTAL WATER REMOVED DURING DEVELOPMENT: _____ GALLONS
 DESCRIPTION OF TURBIDITY AT END OF DEVELOPMENT: CLEAR SLIGHTLY CLOUDY
 MOD. TURBID VERY MUDDY

ODOR OF WATER:
 WATER DISCHARGED TO: GROUND SURFACE TANK TRUCK
 STORM SEWERS STORAGE TANK
 DRUMS OTHER

DEPTH TO WATER AFTER DEVELOPMENT: _____ FEET

MATERIALS USED
12.0 SACKS OF Marie 20/40 Filtration media SAND
~10 SACKS OF _____ CEMENT
~10 GALLONS OF GROUT USED
75 125# POUNDS OF BENTONITE PELLETS 1 1/2 buckets
10 FEET OF 2 INCH PVC BLANK CASING
10 FEET OF 2 INCH 1/8 SLOTTED SCREEN
2 FT of 2 inch 55 silt trap.

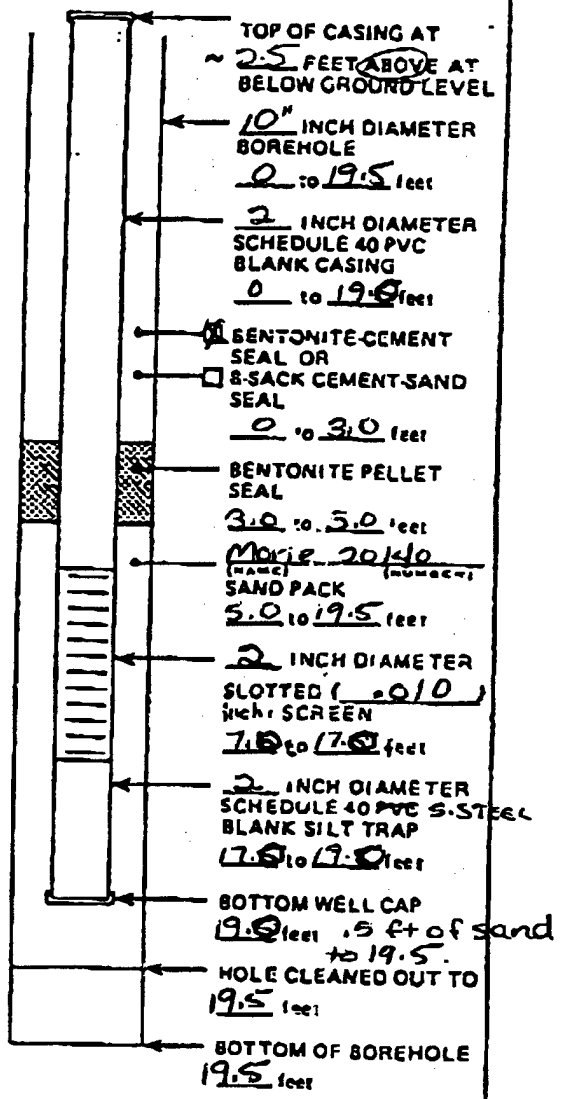

NOT TO SCALE
 ADDITIONAL INFORMATION:
calculated sand = 11.31 SACKS
calculated grout = 11.76 gal

CONCRETE PUMPER USED? NO YES
 NAME grout mixed in 55 gal drum
 WELL COVER USED: LOCKING STEEL COVER
 CHRISTY BOX
 OTHER _____



FIELD WELL COMPLETION FORM

JOB NAME: Foker AFB

JOB NUMBER: 0114 PROJECT MANAGER: Allan Jenkins

LOGGED BY: G. Miller EDITED BY:

WELL NAME: MW1124 DATE: 8/12/95

DRILLING COMPANY: Tri state Testing Services

EQUIPMENT: 10 INCH HOLLOW STEM AUGER DRILLER: J. Crawford
 INCH ROTARY WASH HOURS DRILLED:

GALLONS OF WATER USED DURING DRILLING: 50 GALLONS

METHOD OF DECONTAMINATION PRIOR TO DRILLING: Steam cleaning

DEVELOPMENT See Well Development form

METHOD OF DEVELOPMENT:

DEVELOPMENT BEGAN DATE: _____ TIME: _____ DATE: _____

YIELD:	GPM	TIME: FROM	TO	DATE:
YIELD:	GPM	TIME: FROM	TO	DATE:
YIELD:	GPM	TIME: FROM	TO	DATE:
YIELD:	GPM	TIME: FROM	TO	DATE:

TOTAL WATER REMOVED DURING DEVELOPMENT: _____ GALLONS

DESCRIPTION OF TURBIDITY AT END OF DEVELOPMENT: CLEAR SLIGHTLY CLOUDY
 MOD. TURBID VERY MUDDY

ODOR OF WATER:

WATER DISCHARGED TO: GROUND SURFACE TANK TRUCK
 STORM SEWERS STORAGE TANK
 DRUMS OTHER _____

DEPTH TO WATER AFTER DEVELOPMENT: _____ FEET

MATERIALS USED

- 12 1/2 SACKS OF Morie 20/40 Filtration media SAND
- _____ SACKS OF _____ CEMENT
- 265 GALLONS OF GROUT USED
- _____ SACKS OF POWDERED BENTONITE
- 50 POUNDS OF BENTONITE PELLETS 1 1/2 buckets
- 30 FEET OF 2 INCH PVC BLANK CASING 2 Feet of cut
- 10 FEET OF 2 INCH 35 SLOTTED SCREEN 006
- 2 FT of 2 inch ss silt trap
- _____ YARD³ CEMENT-SAND (REDI-MIX) ORDERED
- _____ YARD³ CEMENT-SAND (REDI-MIX) USED

CONCRETE PUMPER USED? NO YES

NAME grout mixed in 55 gal drum.

WELL COVER USED: LOCKING STEEL COVER
 CHRISTY BOX
 OTHER _____

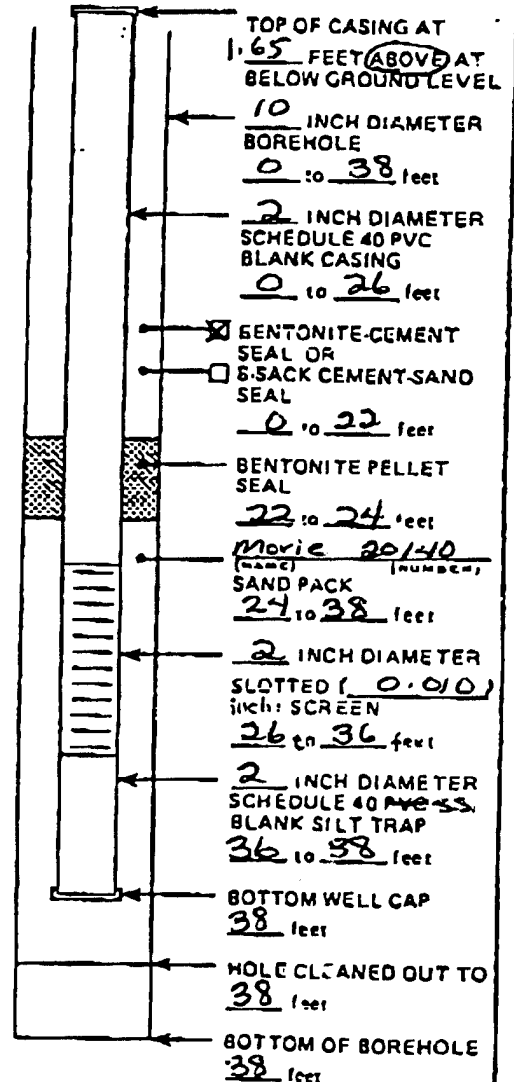
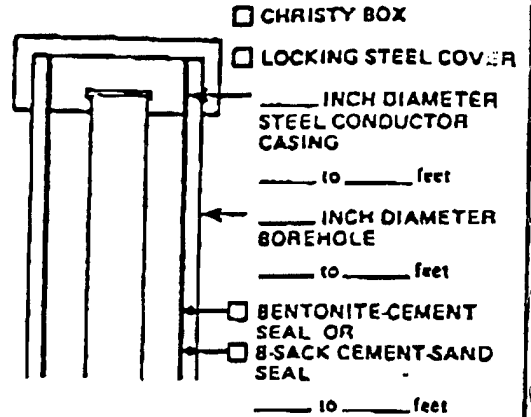

NOT TO SCALE

ADDITIONAL INFORMATION: calculated sand 10.93 sacks
calculated grout 26.24 gal.



FIELD WELL COMPLETION FORM

JOB NAME: Faker AFB
 JOB NUMBER: 0114 PROJECT MANAGER: Allan Jenkins
 LOGGED BY: G. Millar EDITED BY: J. Ellis
 WELL NAME: MW1125 DATE: 10/31/95
 DRILLING COMPANY: Tri State Testing Services
 EQUIPMENT: 7/4 INCH HOLLOW STEM AUGER DRILLER: J. Crawford
 INCH ROTARY WASH HOURS DRILLED: _____

GALLONS OF WATER USED DURING DRILLING: 70 GALLONS
 METHOD OF DECONTAMINATION PRIOR TO DRILLING: Steam Cleaning

DEVELOPMENT See Well Development Form

METHOD OF DEVELOPMENT: _____
 DEVELOPMENT BEGAN DATE: _____ TIME: _____

YIELD:	GPM	TIME: FROM	TO	DATE:

TOTAL WATER REMOVED DURING DEVELOPMENT: _____ GALLONS
 DESCRIPTION OF TURBIDITY AT END OF DEVELOPMENT: CLEAR SLIGHTLY CLOUDY
 MOD. TURBID VERY MUDDY

ODOR OF WATER: _____
 WATER DISCHARGED TO: GROUND SURFACE TANK TRUCK
 STORM SEWERS STORAGE TANK
 DRUMS OTHER _____

DEPTH TO WATER AFTER DEVELOPMENT: _____ FEET JK

MATERIALS USED
9 SACKS OF 090895 GR CON WELL SAND
 _____ SACKS OF _____ CEMENT
 _____ GALLONS OF GROUT USED
 _____ SACKS OF POWDERED BENTONITE
 _____ POUNDS OF BENTONITE PELLETS 1 1/4 buckets
30 FEET OF 2 INCH PVC BLANK CASING 1.5ft. cut off.
10 FEET OF 2 INCH SS SLOTTED SCREEN
2 FT of 2 inch SS silt trap
 _____ YARD³ CEMENT-SAND (REDI-MIX) ORDERED
 _____ YARD³ CEMENT-SAND (REDI-MIX) USED

CONCRETE PUMPER USED? NO YES
 NAME _____
 WELL COVER USED: LOCKING STEEL COVER
 CHRISTY BOX
 OTHER _____

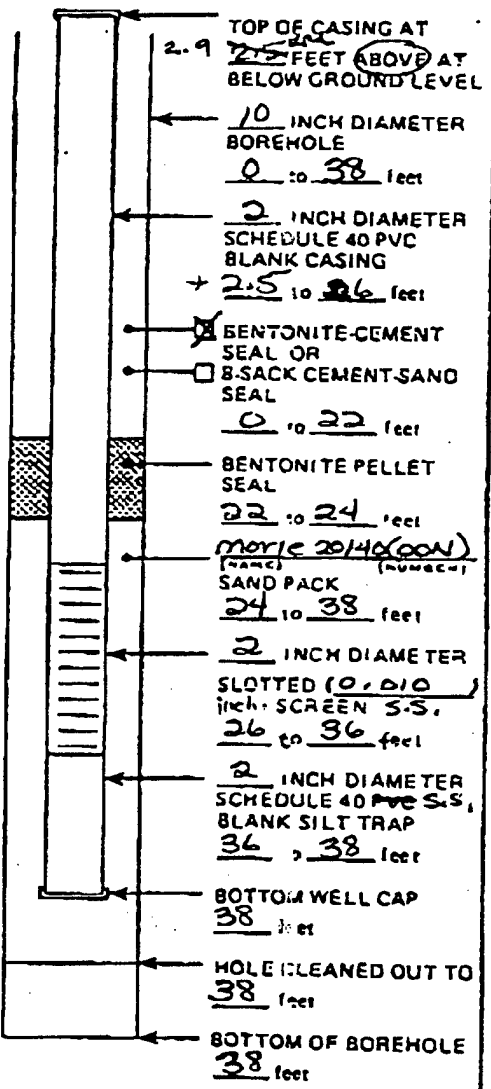
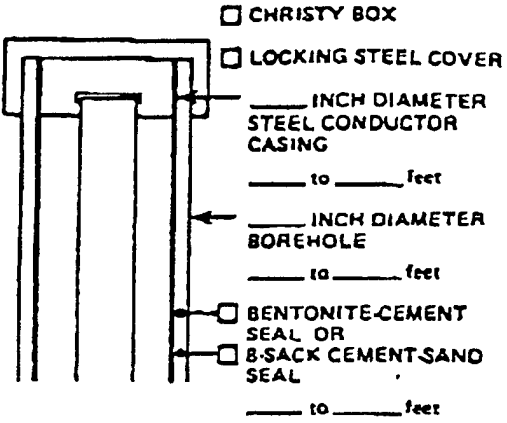

NOT TO SCALE
 ADDITIONAL INFORMATION: _____
Calculated Sand = 10.92 sacks
calculated grout = 50.36 gals



FIELD WELL COMPLETION FORM

JOB NAME: Fakur AFB
 JOB NUMBER: 0114 PROJECT MANAGER: Allan Jenkins
 LOGGED BY: G. Millar EDITED BY:
 WELL NAME: MW1126 DATE: 11/01/95
 DRILLING COMPANY: Tri-state Testing Services
 EQUIPMENT: 7/4 INCH HOLLOW STEM AUGER DRILLER: J. Crawford
 INCH ROTARY WASH HOURS DRILLED:

GALLONS OF WATER USED DURING DRILLING: 52 GALLONS *to equalize pressure*

METHOD OF DECONTAMINATION PRIOR TO DRILLING: steam cleaning

DEVELOPMENT See Well Development Form

METHOD OF DEVELOPMENT:

YIELD:	GPM	TIME: FROM	TO	DATE:

TOTAL WATER REMOVED DURING DEVELOPMENT: _____ GALLONS

DESCRIPTION OF TURBIDITY AT END OF DEVELOPMENT: CLEAR SLIGHTLY CLOUDY MOD. TURBID VERY MUDDY

ODOR OF WATER:

WATER DISCHARGED TO: GROUND SURFACE TANK TRUCK STORM SEWERS STORAGE TANK DRUMS OTHER

DEPTH TO WATER AFTER DEVELOPMENT: _____ FEET

MATERIALS USED

- 9 1/2 SACKS OF 0908956A CONWELL Marie 2040 Filtration media SAND
- _____ SACKS OF _____ CEMENT
- _____ GALLONS OF GROUT USED
- _____ SACKS OF POWDERED BENTONITE
- 50 POUNDS OF BENTONITE PELLETS 1 bucket
- 35 FEET OF 2 INCH PVC BLANK CASING 3.5ft cut off
- 10 FEET OF 2 INCH ^{S.S.} PVC SLOTTED SCREEN
- 2 FT of 2 inch S.S. silt trap
- _____ YARD³ CEMENT-SAND (REDI-MIX) ORDERED
- _____ YARD³ CEMENT-SAND (REDI-MIX) USED

CONCRETE PUMPER USED? NO YES

NAME _____

WELL COVER USED: LOCKING STEEL COVER CHRISTY BOX OTHER _____

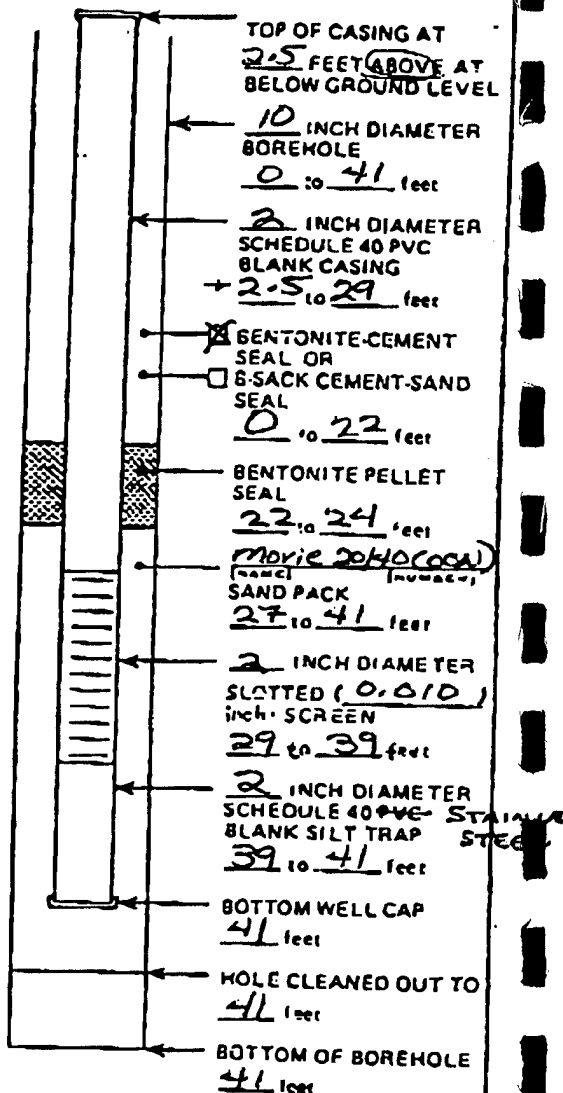
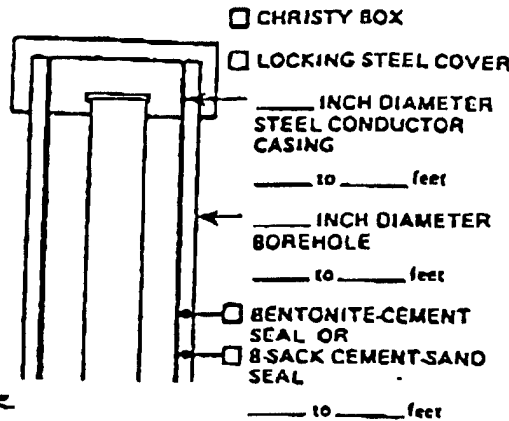

NOT TO SCALE

ADDITIONAL INFORMATION: calculated sand = 10.92 bags
calculated grout = 98 gals

SURVDATA.XLS

SAMPLE LOCATION/ELEVATION
EAKER AIR FORCE BASE, ARKANSAS

Sample Point	Elevation TOC	Ground Elevation	Coordinates		Site
			Northing	Easting	
TW1102	249.52		599301.20	2604930.49	BX
TW1103	249.99		599245.87	2605004.10	BX
MW1104	251.48		599380.79	2605116.02	BX
TW1105	251.14		599340.38	2604984.22	BX
TW1106	250.98		599356.10	2604925.65	BX
TW1107	251.31		599377.34	2605044.84	BX
TW1108	250.75		599297.47	2605018.95	BX
TW1109	250.89		599269.70	2605047.84	BX
MW1110	251.23		599285.35	2605052.46	BX
MW1111	251.32		599445.92	2605047.22	BX
TW1112	250.86		599348.57	2605017.22	BX
TW1113	252.01		599449.00	2604918.04	BX
MW1114	251.64		599513.89	2604985.04	BX
MW1115	250.37		599355.32	2604845.78	BX
MW1116	250.62		599187.31	2604940.79	BX
TW1117	250.83		599261.14	2605070.50	BX
TW1118	250.42		599233.00	2605100.52	BX
MW1119	249.75		599198.81	2605113.49	BX
MW1120	251.73		599447.41	2604838.18	BX
MW1121	253.16	250.97	599307.09	2605212.18	BX
MW1122	253.02	250.68	599488.98	2605029.14	BX
MW1123	253.56	251.13	599426.94	2604884.90	BX
MW1124	253.58	251.93	599440.75	2604894.57	BX
MW1125	253.48	250.88	599527.92	2604778.84	BX
MW1126	253.70	250.91	599313.88	2605207.14	BX
MW1127	250.56	250.76	599181.58	2604946.87	BX
MW1128	STILL REMAINING TO BE SURVEYED				BX
CF03		251.12	599361.54	2604978.20	BX
CF19					BX
CF22					BX
CF26		251.12	599356.27	2604925.70	BX
B1		252.18	599386.58	2605029.03	BX
B2		251.96	599388.57	2605019.62	BX
B3		251.85	599388.65	2605008.02	BX
B4		251.75	599381.05	2604999.58	BX
B5		251.64	599373.17	2604995.29	BX
B6		251.77	599350.54	2604998.47	BX
B7		250.97	599348.42	2605017.32	BX
B8		250.98	599340.55	2605031.63	BX
B9		251.12	599347.35	2605041.38	BX
B10		251.23	599354.04	2605048.24	BX
B11		251.26	599361.16	2605055.91	BX
B12		251.56	599376.42	2605049.23	BX
B13		252.50	599393.30	2605039.89	BX

APPENDIX B - 1C

CPT/LIF OUTPUT

BX SHOPPETTE

Source: USACE 1995.

20
19
18
17
16
15
12
13

29
28
27
26
1
22
31

CPT based SOIL CLASSIFICATION

Clays
Silt Mixtures
Sand
Sands & Gravels

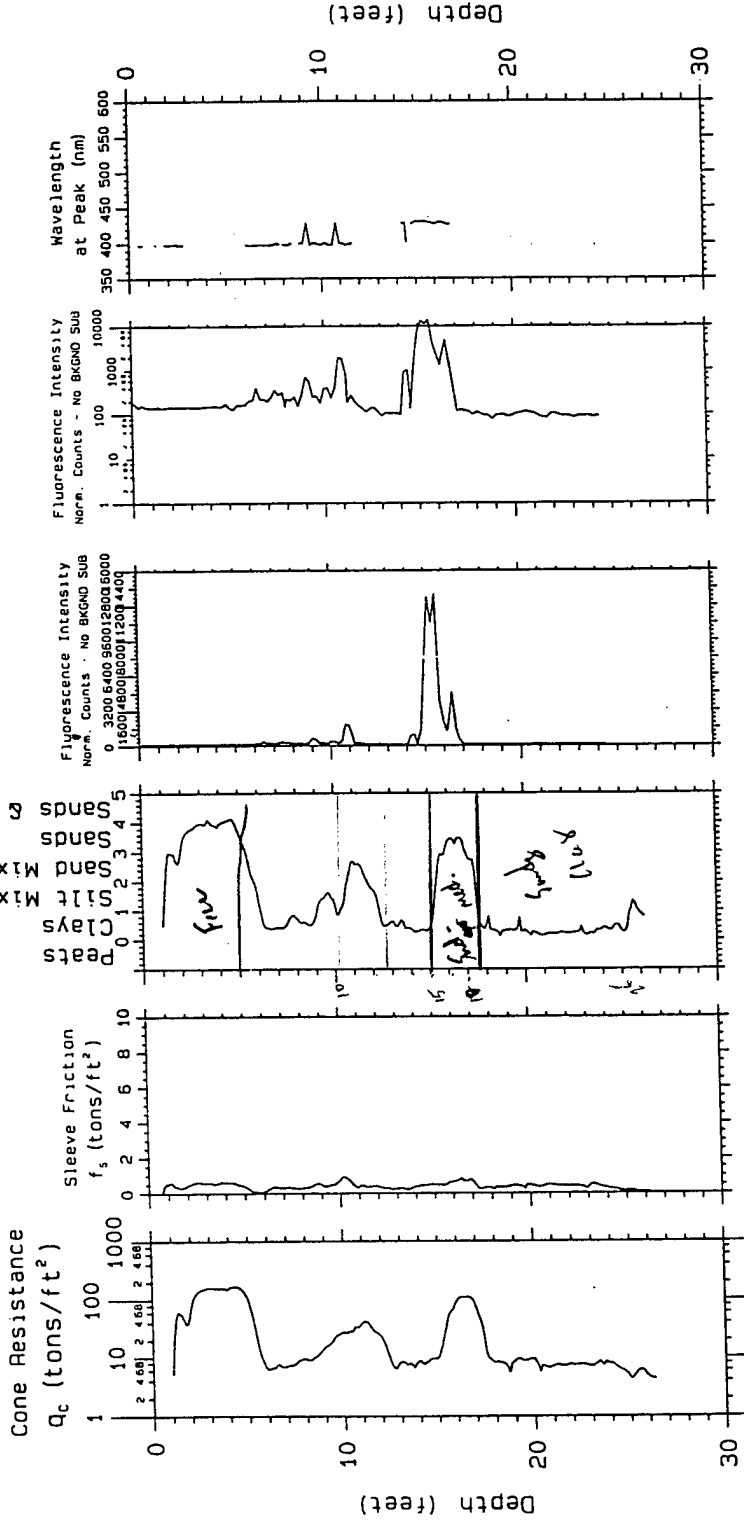

Laser induced fluorescence of POL via fiber optics

U.S. Army Engineer District Kansas City Geotechnical Branch

Project: Eaker AFB <NEW>
Probe Depth: 26.50

SCAPS

Site Characterization and Analysis Penetrometer System

CPT; 01EAK01

Probing date: 03-24-1995

CPT based SOIL CLASSIFICATION

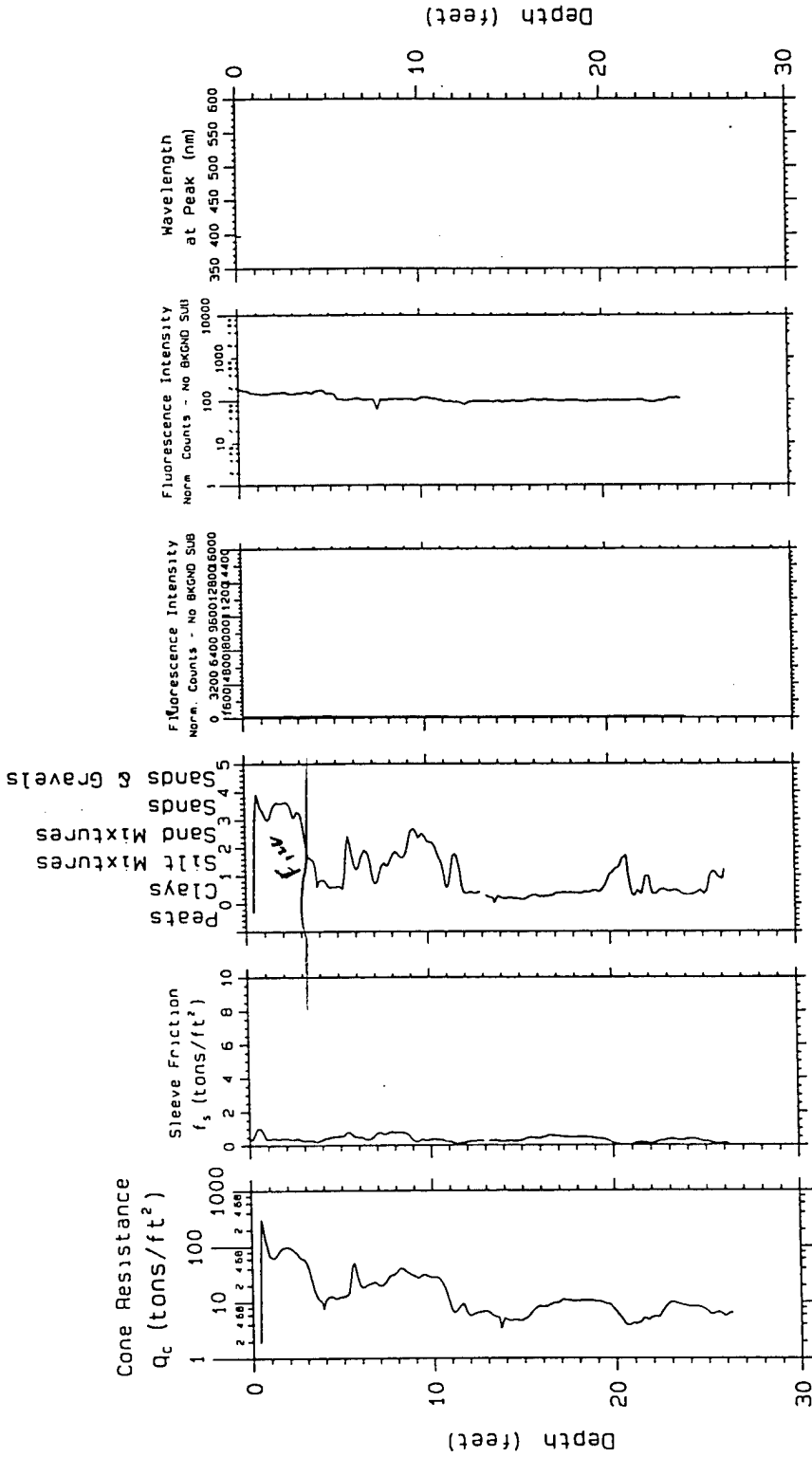

Project; Eaker AFB
Probe Depth; 26.45

Laser induced fluorescence of POL via fiber optics

U.S. Army Engineer District Kansas City Geotechnical Branch

SCAPS
Site Characterization and Analysis Penetrometer System

CPT; 2EAK01

CPT based SOIL CLASSIFICATION

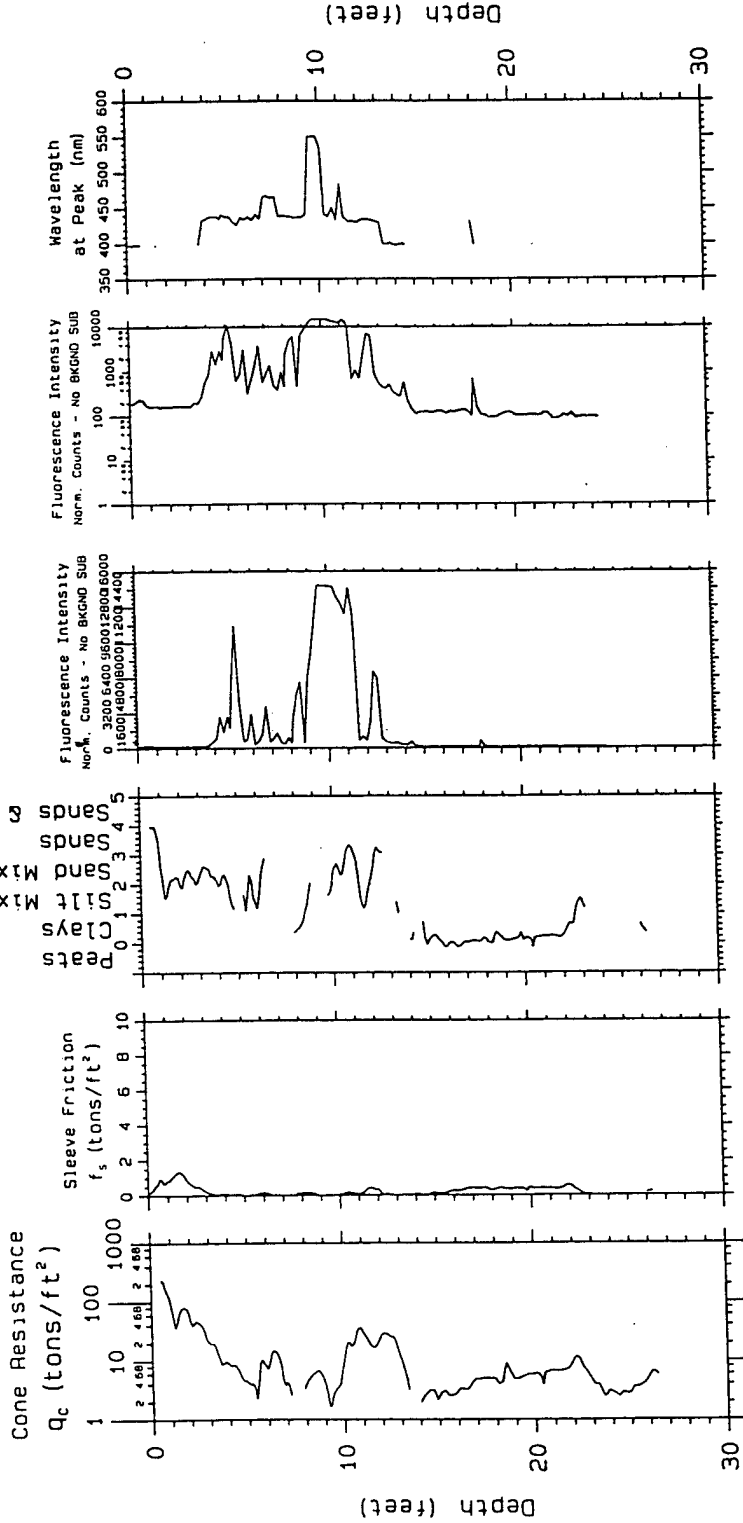

Project; Eaker AFB
 Probe Depth; 26.54

Site Characterization and Analysis Penetrometer System
CPT; 3EAK01

SCAPS

Laser induced fluorescence of PDL via fiber optics

U.S. Army Engineer District Kansas City Geotechnical Branch

Probing date; 03-24-1995

CPT based SOIL CLASSIFICATION

0 1 2 3 4 5
 Clays
 Silt Mixtures
 Sand Mixtures
 Sands & Gravels

Cone Resistance
 Q_c (tons/ft²)

1 10 100 1000

Sleeve Friction
 f_s (tons/ft²)

0 2 4 6 8 10

Fluorescence Intensity
 Norm. Counts - No BKGD Sub
 0 3200 6400 9600 12800 16000

Fluorescence Intensity
 Norm. Counts - No BKGD Sub
 1 10 100 1000 10000

Wavelength
 at Peak (nm)
 350 400 450 500 550 600

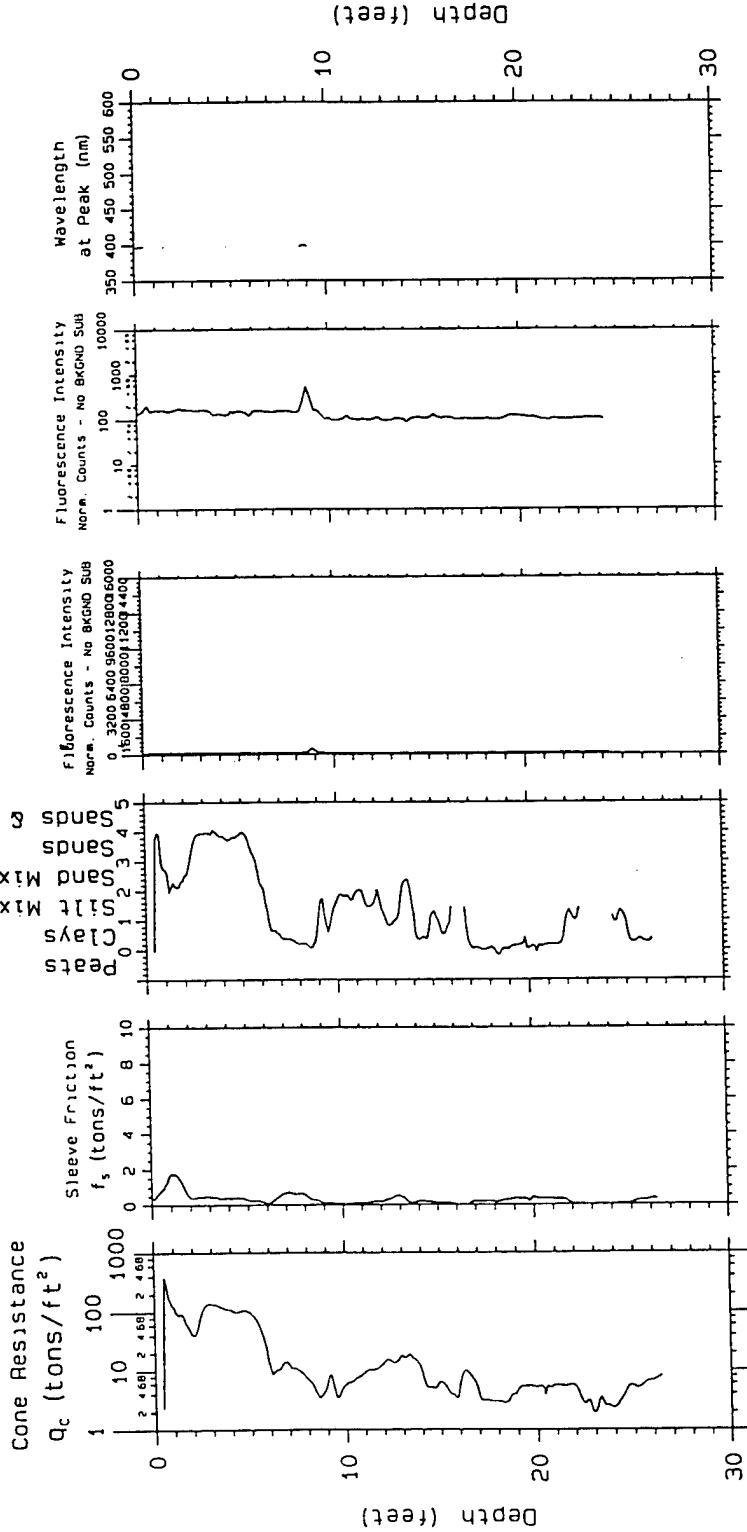

Project; Eaker AFB
 Probe Depth; 26.59

Site Characterization
 and Analysis
 Penetrometer System
CPT; 4EAK01

SCAPS

Laser induced
 fluorescence
 of POL via
 fiber optics

U.S. Army
 Engineer
 District
 Kansas City
 Geotechnical Branch

Printed date: 03-24-1995

CPT based SOIL CLASSIFICATION

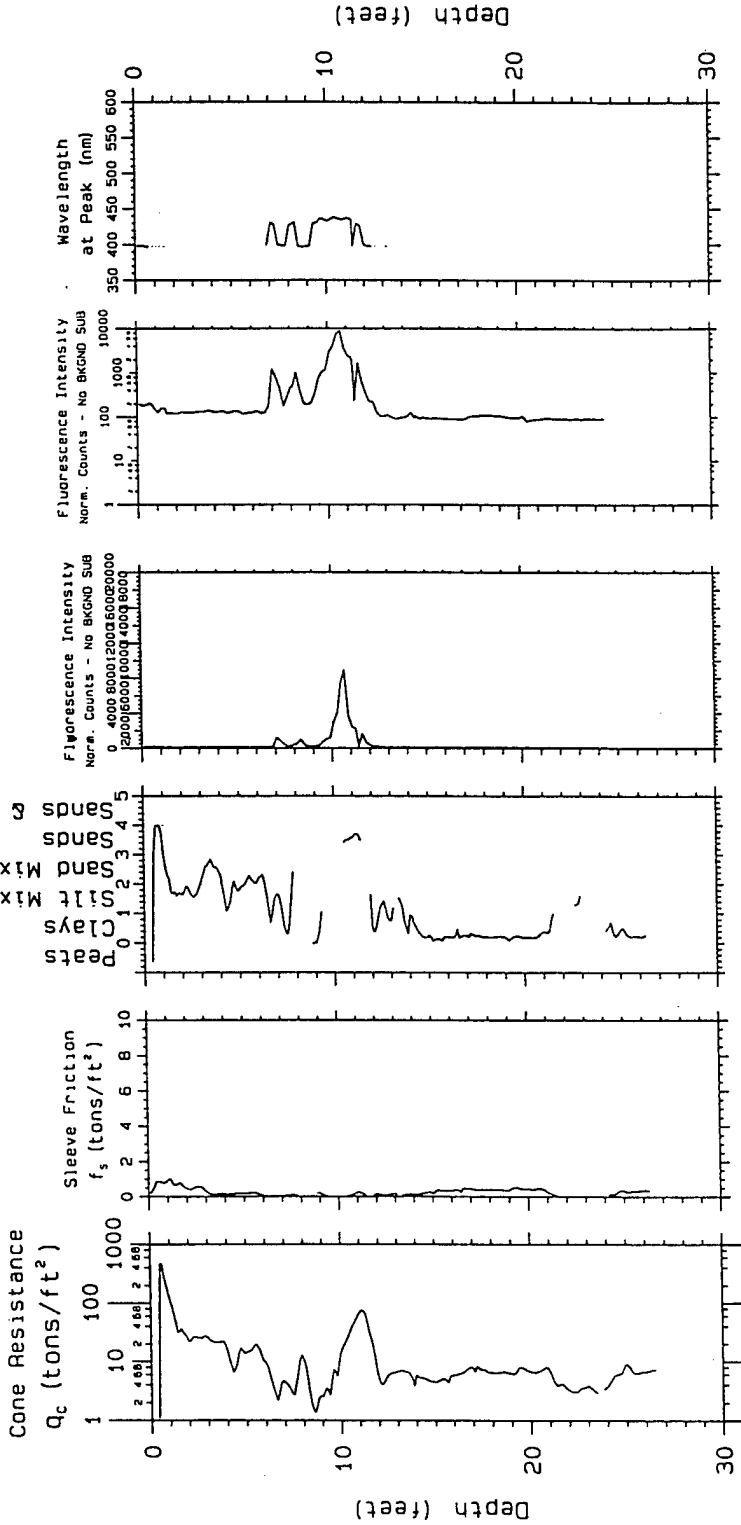

Laser induced fluorescence of POL via fiber optics

U.S. Army Engineer District Kansas City Geotechnical Branch

SCAPS

Site Characterization and Analysis Penetrometer System

CPT; 5EAK01

Project; Eaker AFB
Probe Depth; 26.61

Probing date; 03-24-1995

CPT based SOIL CLASSIFICATION

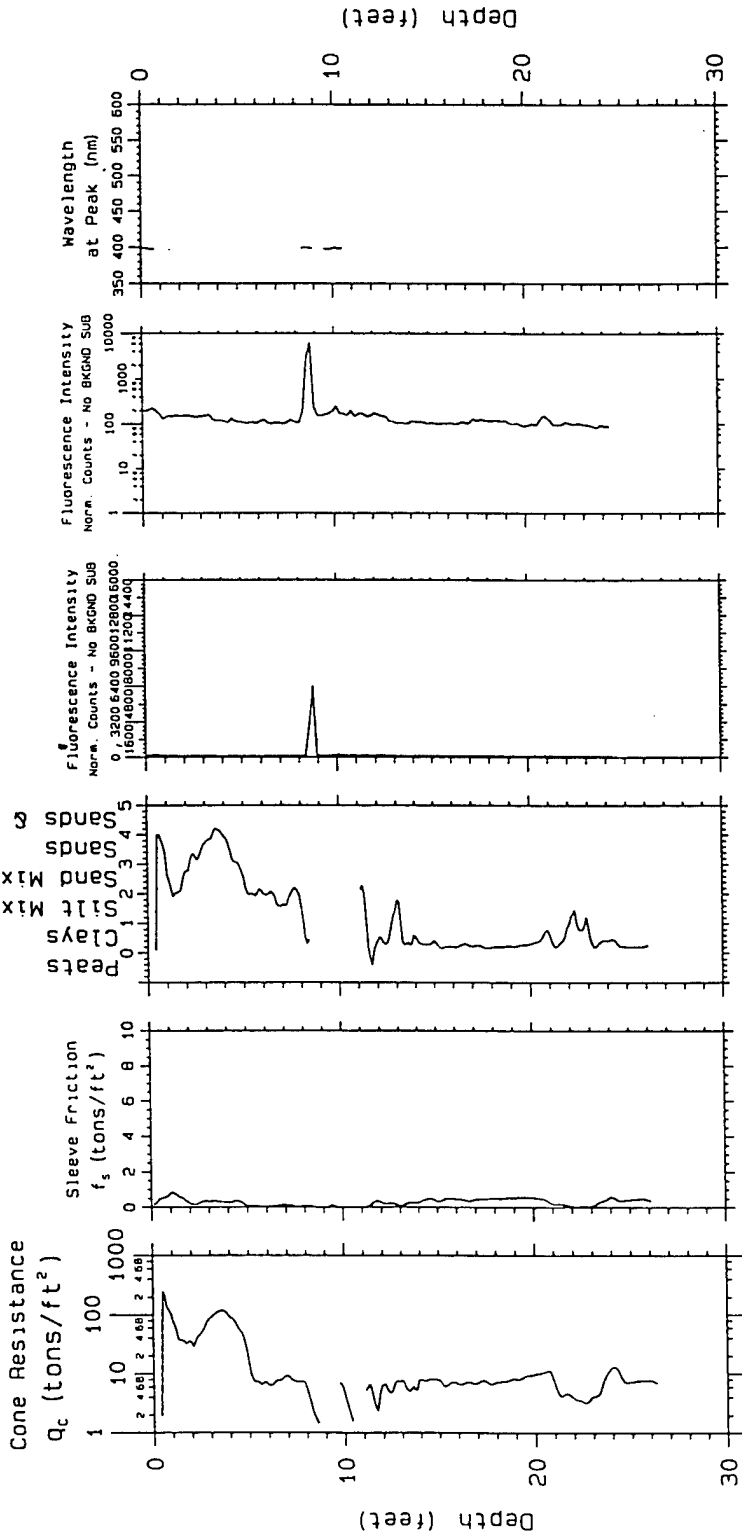

Laser induced fluorescence of POL via fiber optics

U.S. Army Engineer District Kansas City Geotechnical Branch

Probino date: 03-24-1995

Project; Eaker AFB
Probe Depth: 26.50

SCAPS

Site Characterization and Analysis Penetrometer System

CPT; 6EAK01

CPT based SOIL CLASSIFICATION

0 1 2 3 4 5
 Sands & Gravels
 Sands
 Sand Mixtures
 Clays
 Silts
 Clays & Gravels

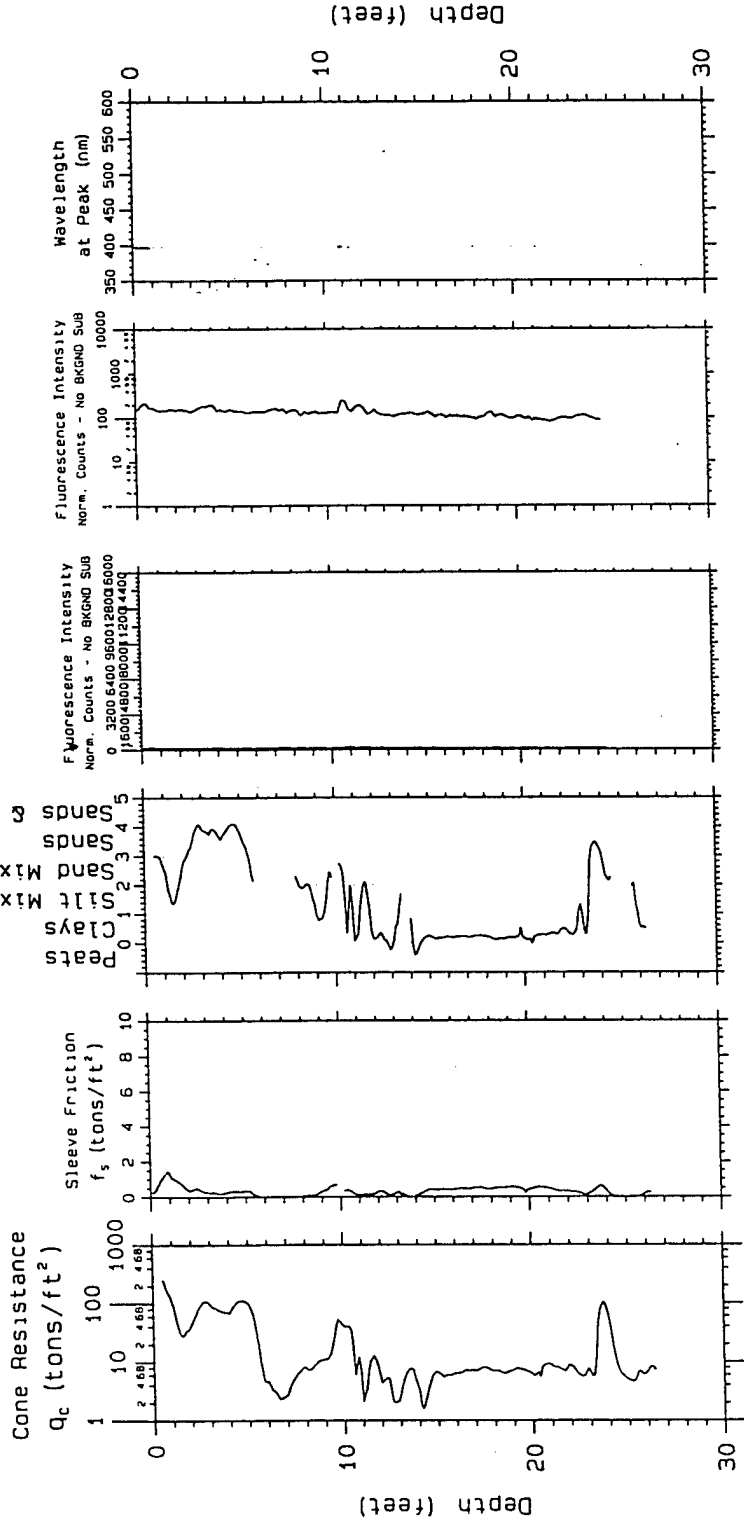

Project; Eaker AFB
 Probe Depth; 26.55

Site Characterization and Analysis Penetrometer System
CPT; 7EAK01



Laser induced fluorescence of POL via fiber optics

U.S. Army Engineer District Kansas City Geotechnical Branch

Probing date; 03-24-1995

CPT based SOIL CLASSIFICATION

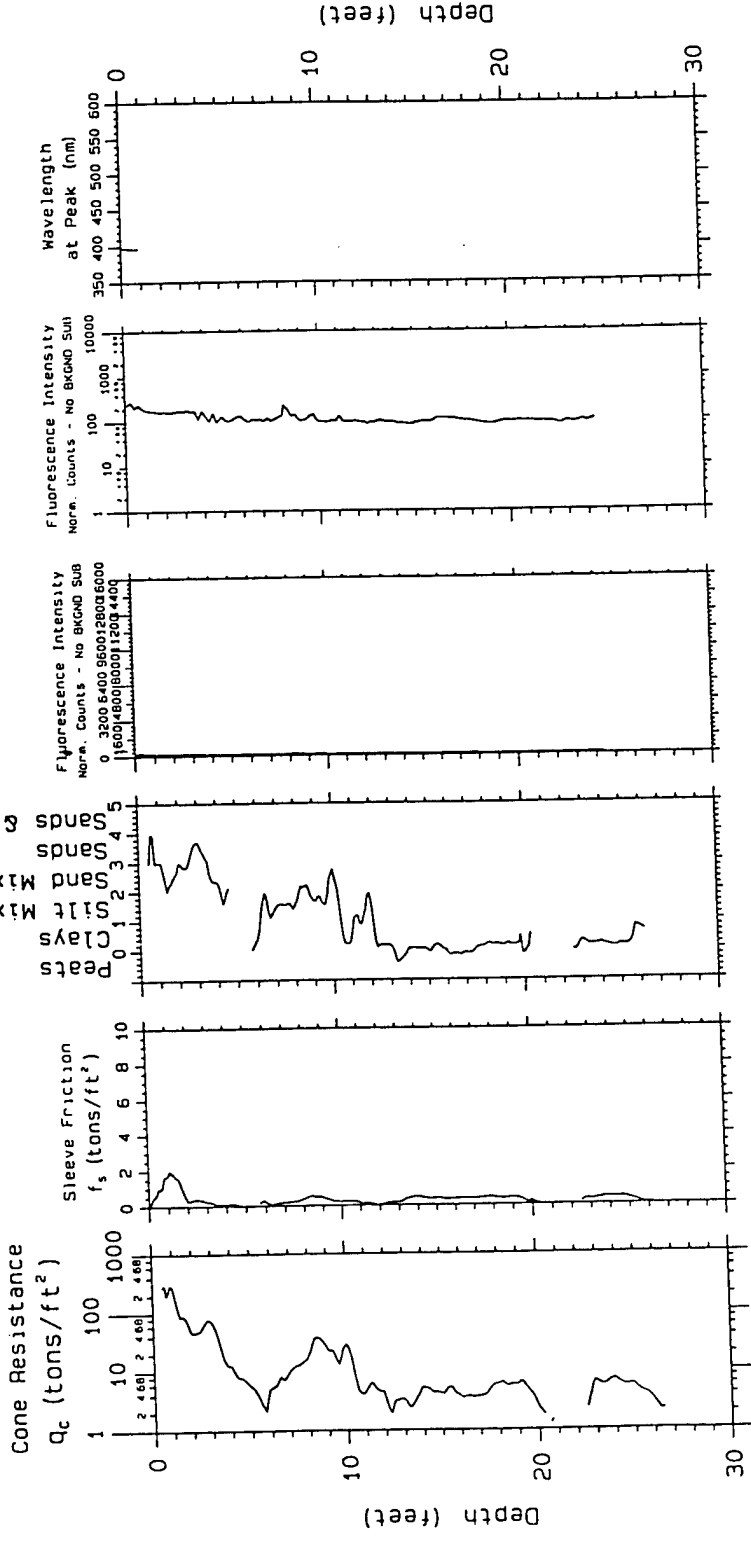

Project; Eaker AFB
 Probe Depth; 26.60

Site
 Characterization
 and Analysis
 Penetrometer System
CPT; 8EAK01

SCAPS

Laser induced
 fluorescence
 of POL via
 fiber optics

U.S. Army
 Engineer
 District
 Kansas City
 Geotechnical Branch

CPT based SOIL CLASSIFICATION

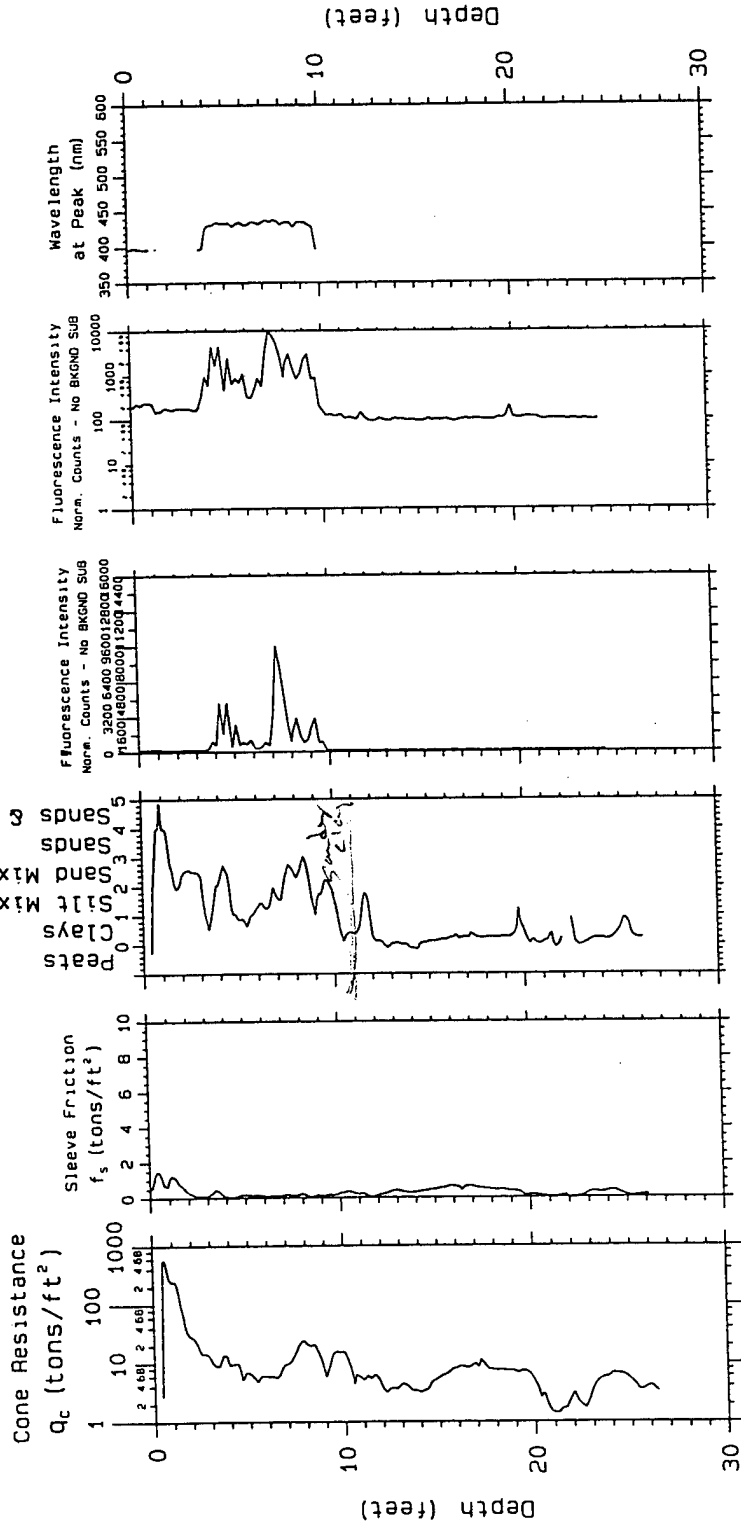

Laser induced fluorescence of PDL via fiber optics

U.S. Army Engineer District Kansas City Geotechnical Branch

Probing date: 03-24-1995

SCAPS

Site Characterization and Analysis Penetrometer System

CPT; 9EAK01

Project; Eaker AFB
Probe Depth: 26.52

MSW 1107

CPT based SOIL CLASSIFICATION

0 to 100% Clays
 100 to 200% Clays
 200 to 300% Sand
 300 to 400% Sand
 400 to 500% Sand
 500 to 600% Sand
 600 to 700% Sand
 700 to 800% Sand
 800 to 900% Sand
 900 to 1000% Sand
 & Gravels

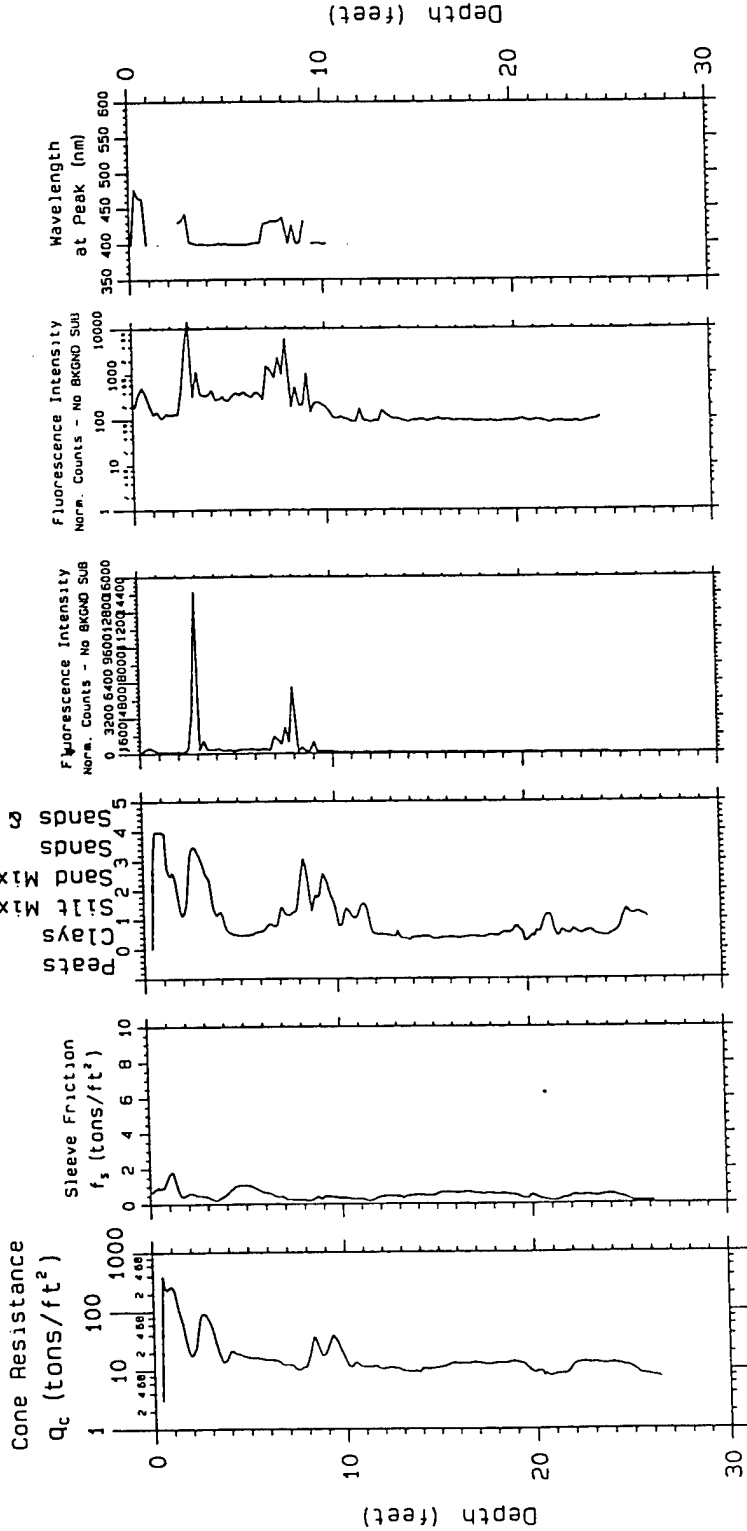

Project; Eaker AFB
 Probe Depth; 26.55

Site Characterization and Analysis Penetrometer System
CPT; 10EAK01

SCAPS

Laser induced fluorescence of POL via fiber optics
 U.S. Army Engineer District Kansas City Geotechnical Branch

Probing date: 03-25-1995

CPT based SOIL CLASSIFICATION

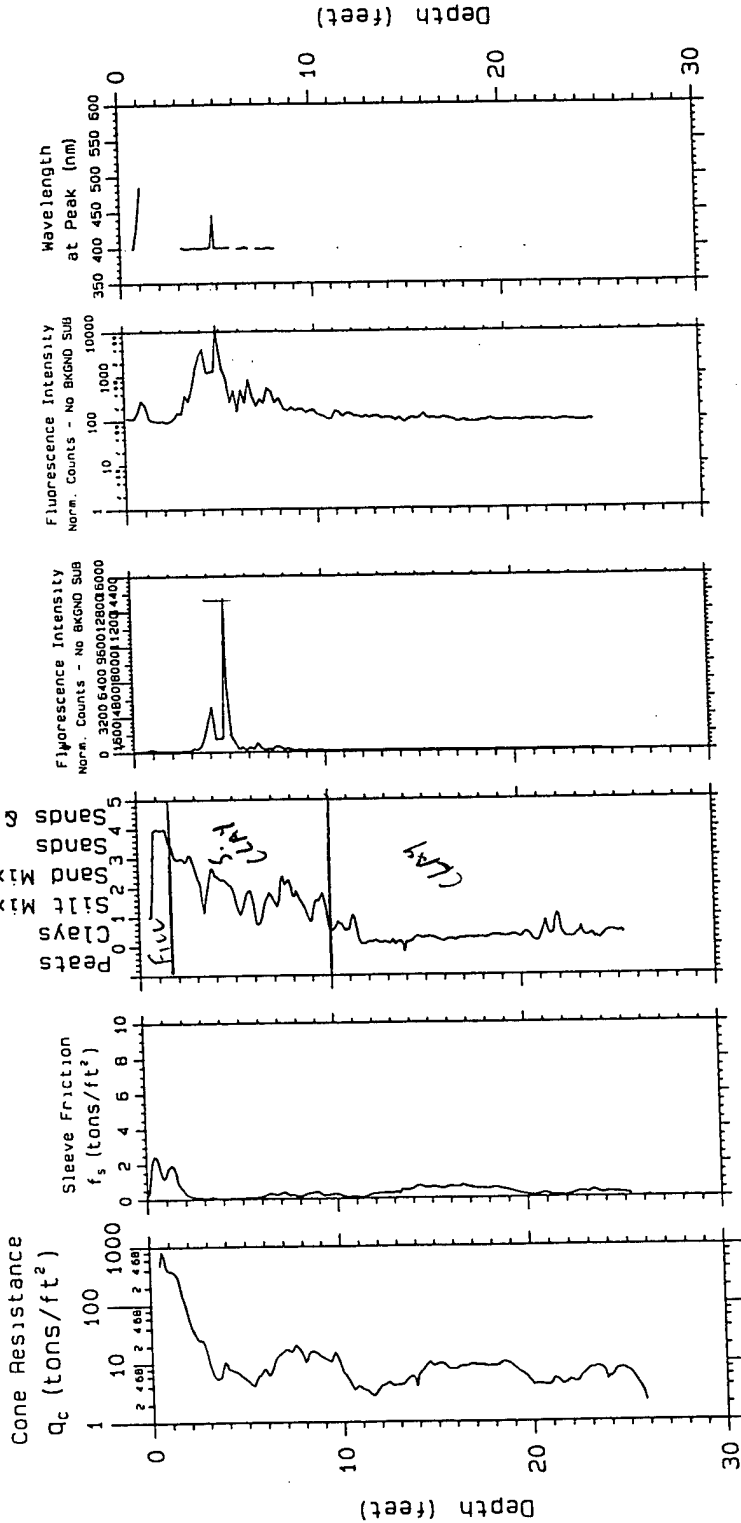

Project; Eaker AFB
 Probe Depth; 26.62

Site Characterization and Analysis Penetrometer System
CPT; 11EAK01



Laser induced fluorescence of POL via fiber optics

U.S. Army Engineer District Kansas City Geotechnical Branch

Probing date: 03-25-1995

CPT based SOIL CLASSIFICATION

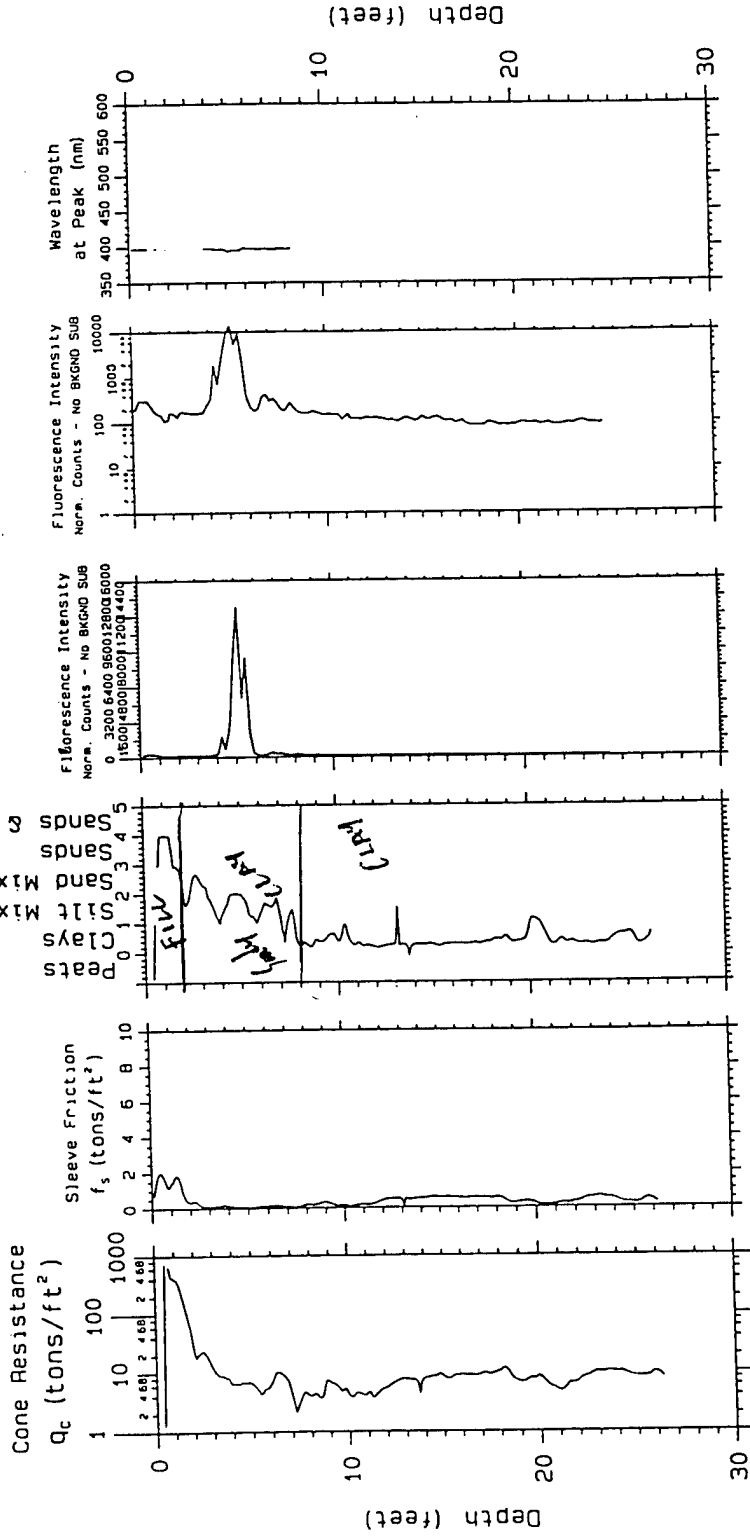

Project; Eaker AFB
 Probe Depth; 26.49

Laser induced fluorescence of POL via fiber optics

U.S. Army Engineer District Kansas City

Site Characterization and Analysis Penetrometer System

SCAPS

CPT; 12EAK01

CPT based SOIL CLASSIFICATION

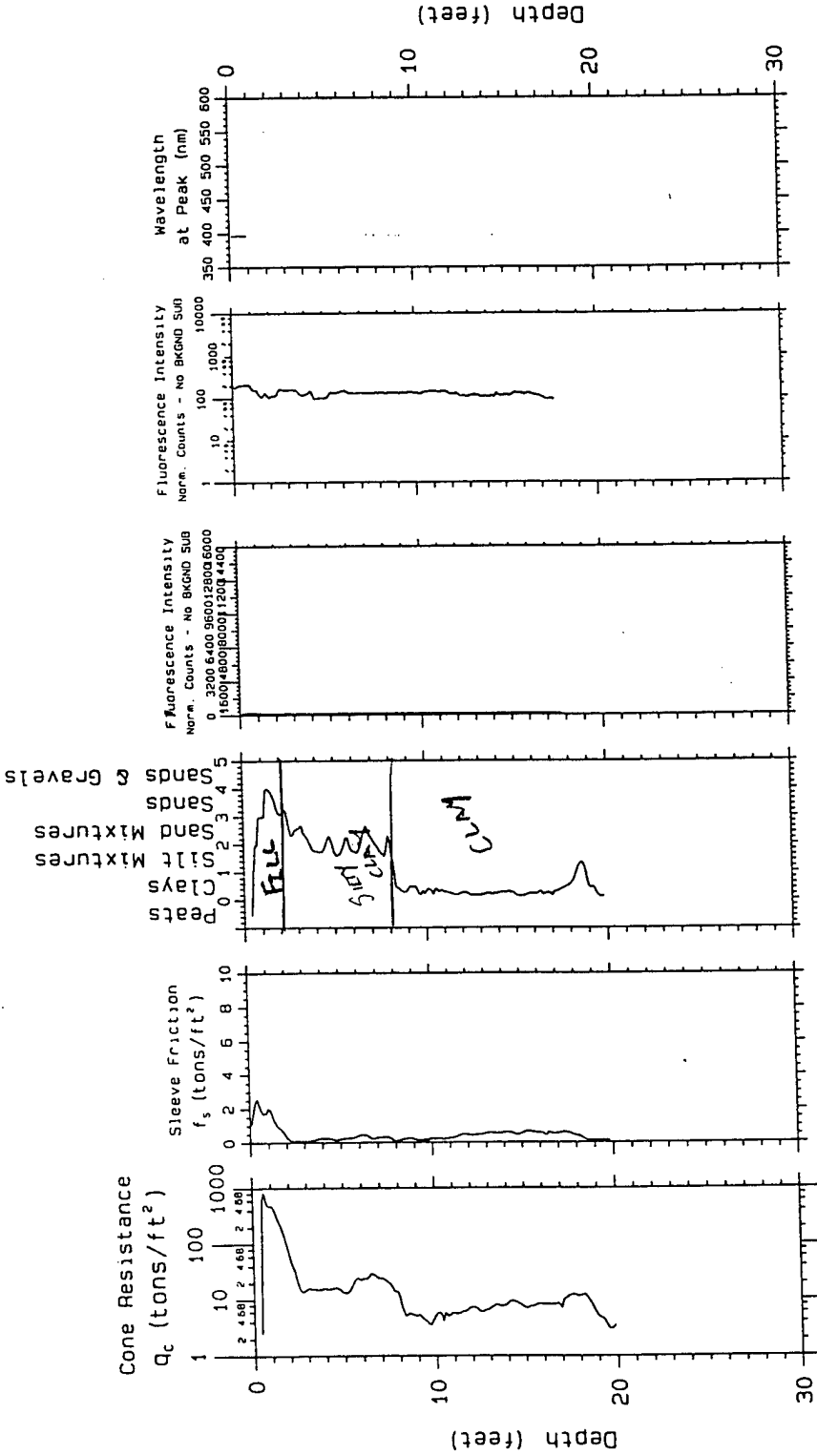

Laser induced fluorescence of POL via fiber optics

U.S. Army Engineer District Kansas City Geotechnical Branch

Probing date: 03-25-1995

SCAPS

Site Characterization and Analysis Penetrometer System

Project; Eaker AFB
Probe Depth: 20.05

CPT; 13EAK01

CPT based SOIL CLASSIFICATION

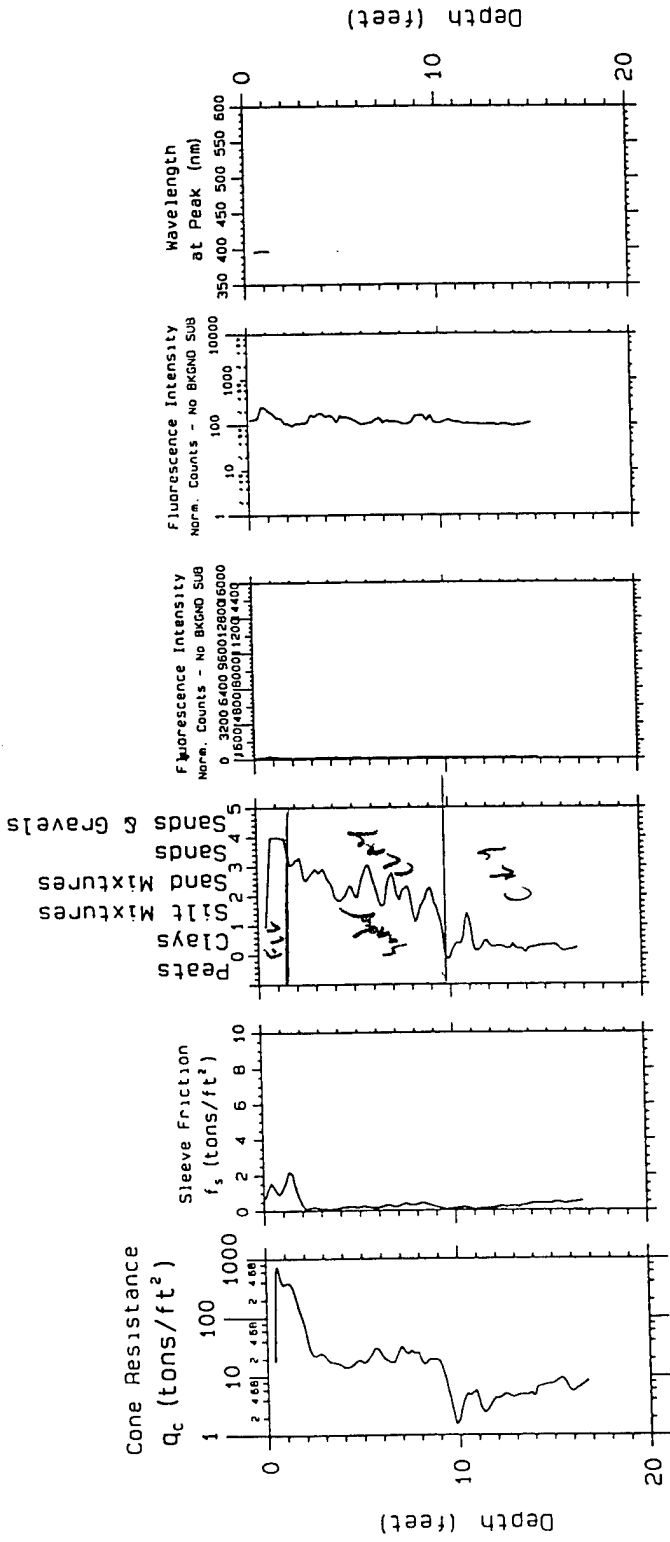

Project; Eaker AFB
 Probe Depth; 17.04

Laser induced
 fluorescence
 of POL via
 fiber optics

U.S. Army
 Engineer
 District
 Dallas
 Geotechnical Branch

SCARS

Site
 Characterization
 and Analysis
 Program

CPT: 14FAK01

Probing date: 03-25-1995

CPT based SOIL CLASSIFICATION

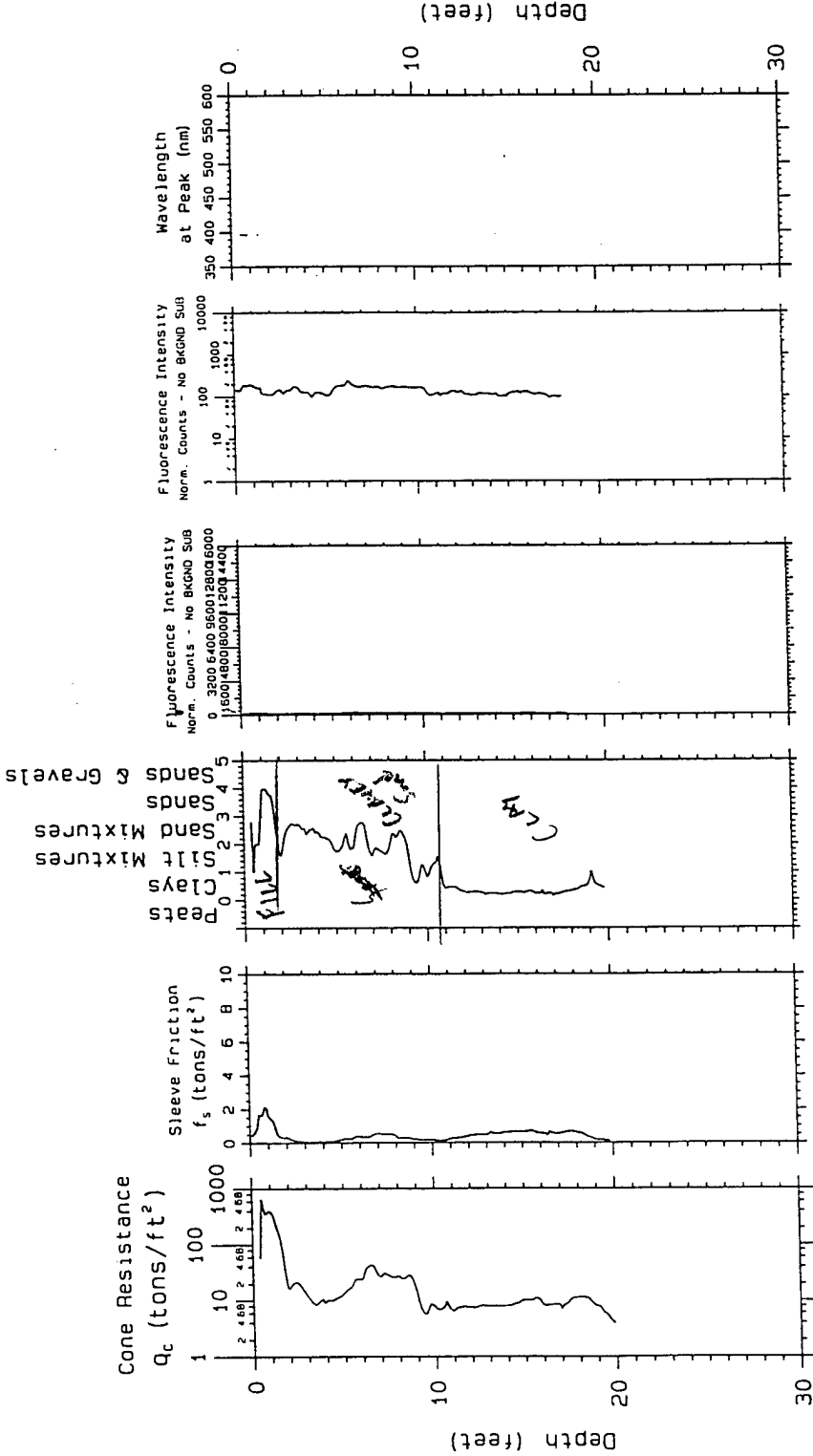

Laser induced fluorescence of PDL via fiber optics

U.S. Army Engineer District Kansas City Geotechnical Branch

Probing date: 03-25-1995

SCAPS

Site Characterization and Analysis Penetrometer System

Project: Eaker AFB
Probe Depth: 20.12

CPT: 15EAK01

CPT based SOIL CLASSIFICATION

0 1 2 3 4 5
 Clays
 Silt Mixtures
 Sand Mixtures
 Sands
 Sands & Gravels

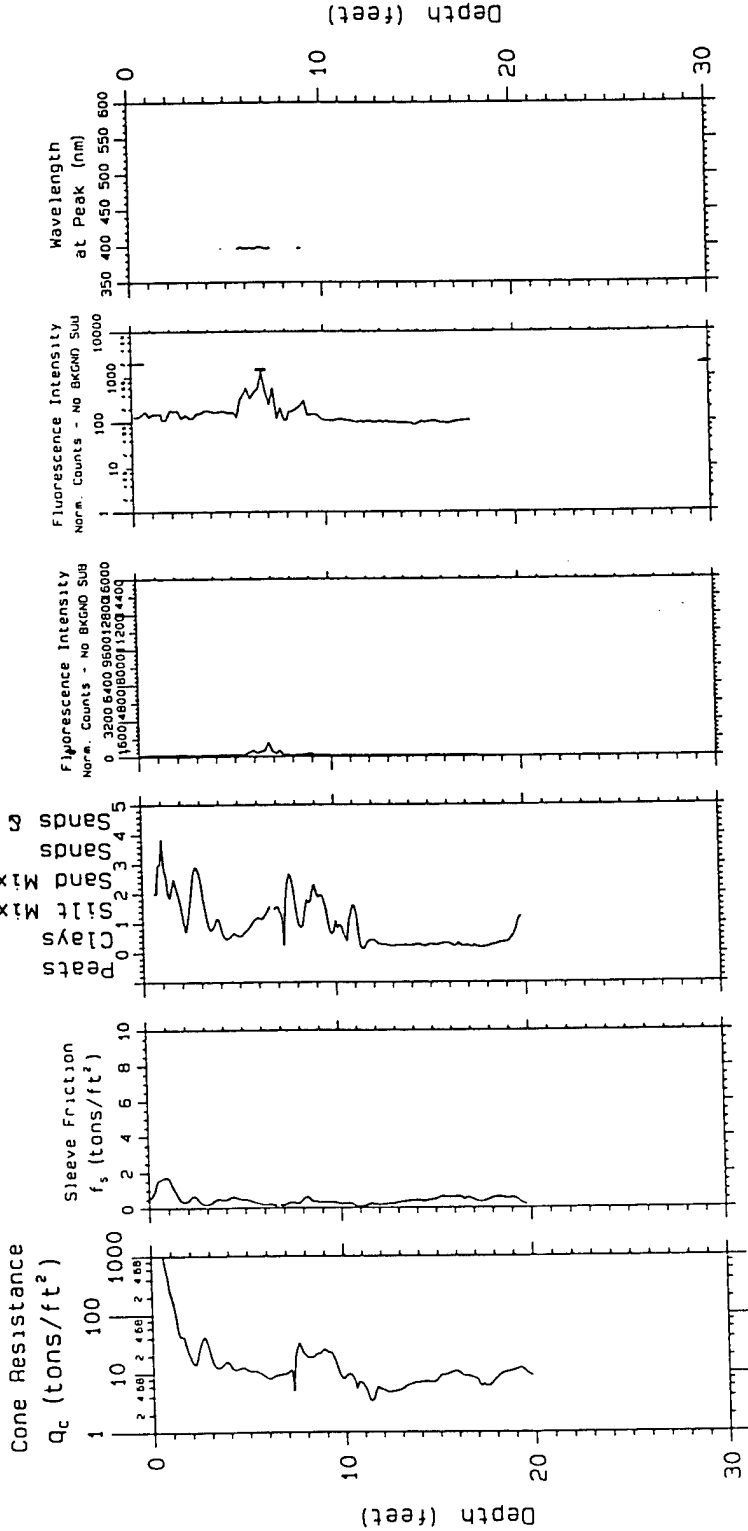

Project; Eaker AFB
 Probe Depth; 20.05

Laser induced
 fluorescence
 of POL via
 fiber optics

U.S. Army
 Engineer
 District
 Kansas City
 (Geotechnical) Branch

SCAPS
 Site
 Characterization
 and Analysis
 Penetrometer System

CPT; 16EAK01

CPT based SOIL CLASSIFICATION

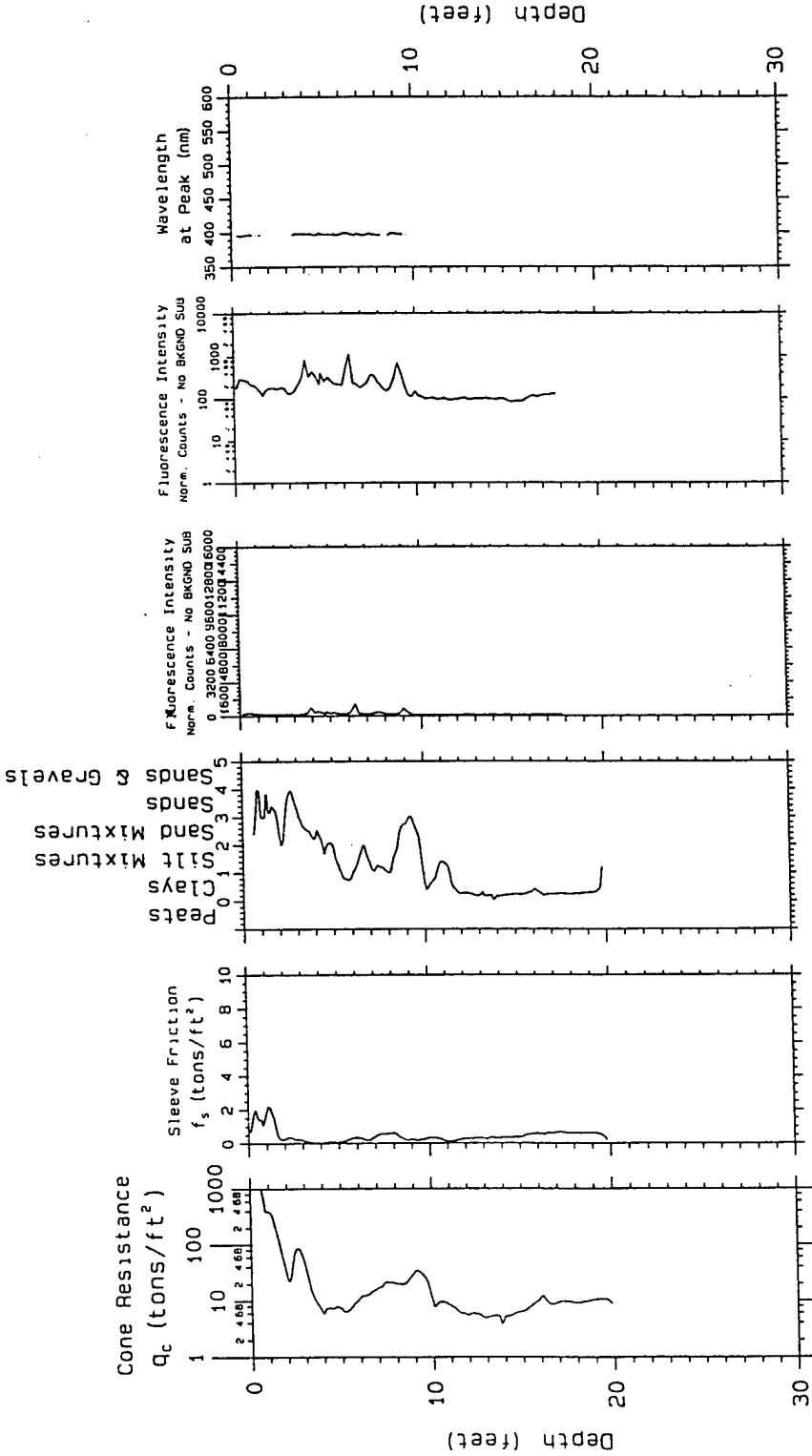

Laser induced fluorescence of PDL via fiber optics

U.S. Army Engineer District Kansas City Geotechnical Branch

Probing date: 03-25-1995

SCAPS

Site Characterization and Analysis Penetrometer System

CPT: 17EAK01

Project: Eaker AFB
 Probe Depth: 20.03

CPT based SOIL CLASSIFICATION

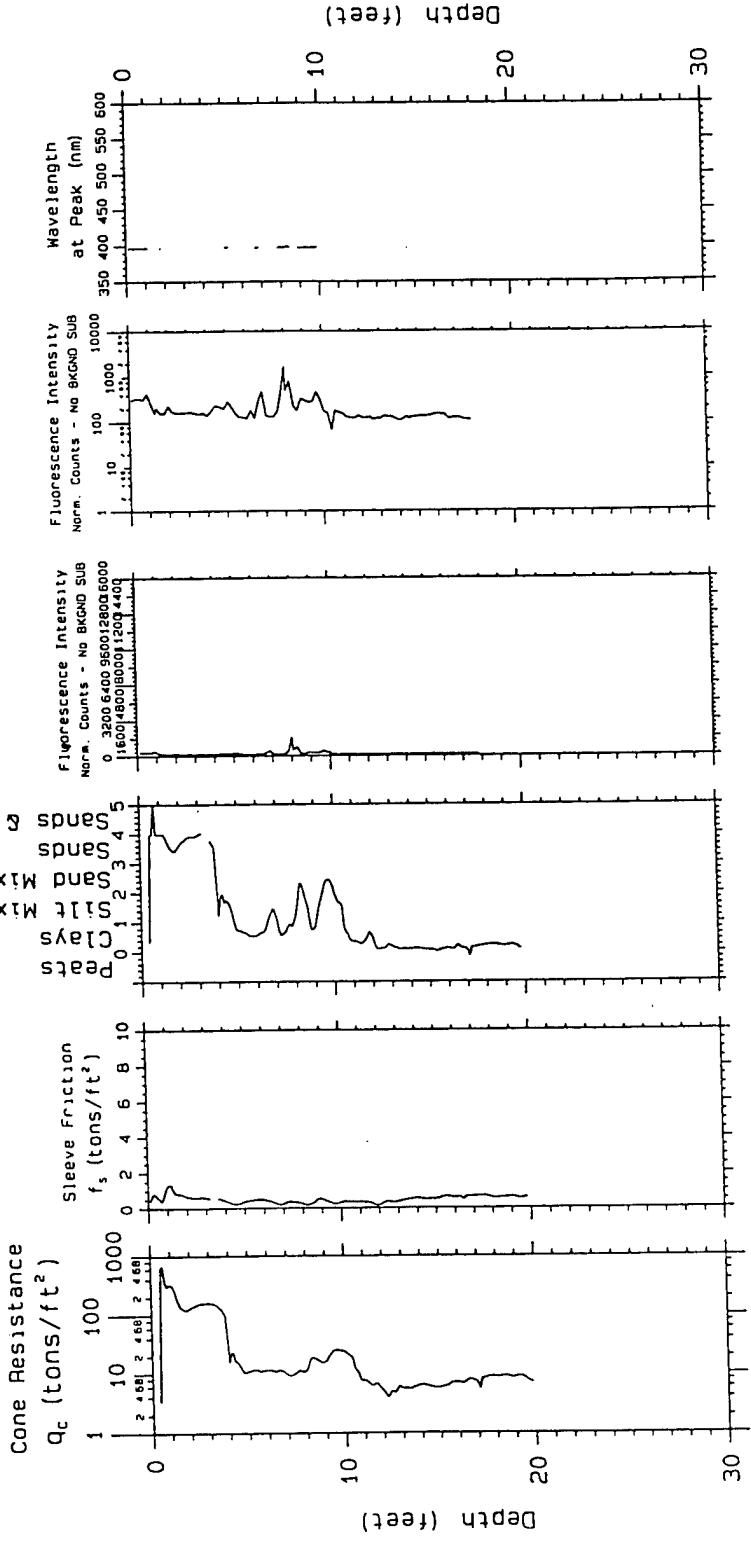

Project; Eaker AFB
 Probe Depth: 20.09

Laser induced fluorescence of POL via fiber optics

U.S. Army Engineer District Kansas City

Site Characterization and Analysis Penetrometer System

SCAPS

CPT; 18EAK01

CPT based SOIL CLASSIFICATION

0 Silts
1 Clays
2 US Silts
3 Sand Mixtures
4 Sand
5 Sands & Gravels

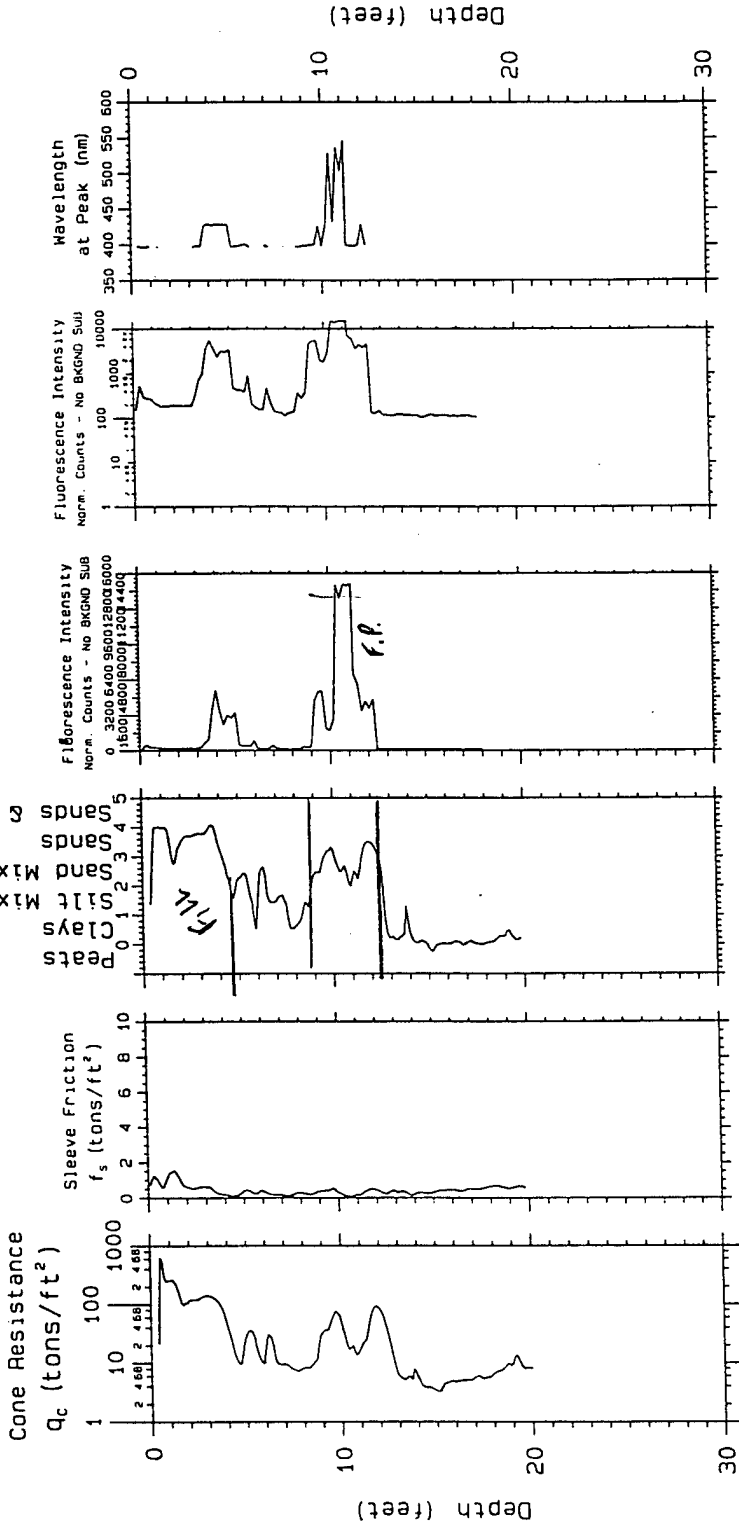

Project; Eaker AFB
Probe Depth; 20.12

Site Characterization and Analysis Penetrometer System
CPT; 19EAK01

SCAPS

Laser induced fluorescence of POL via fiber optics

U.S. Army Engineer District Kansas City Geotechnical Branch

Probing date: 03-25-1995

CPT based SOIL CLASSIFICATION

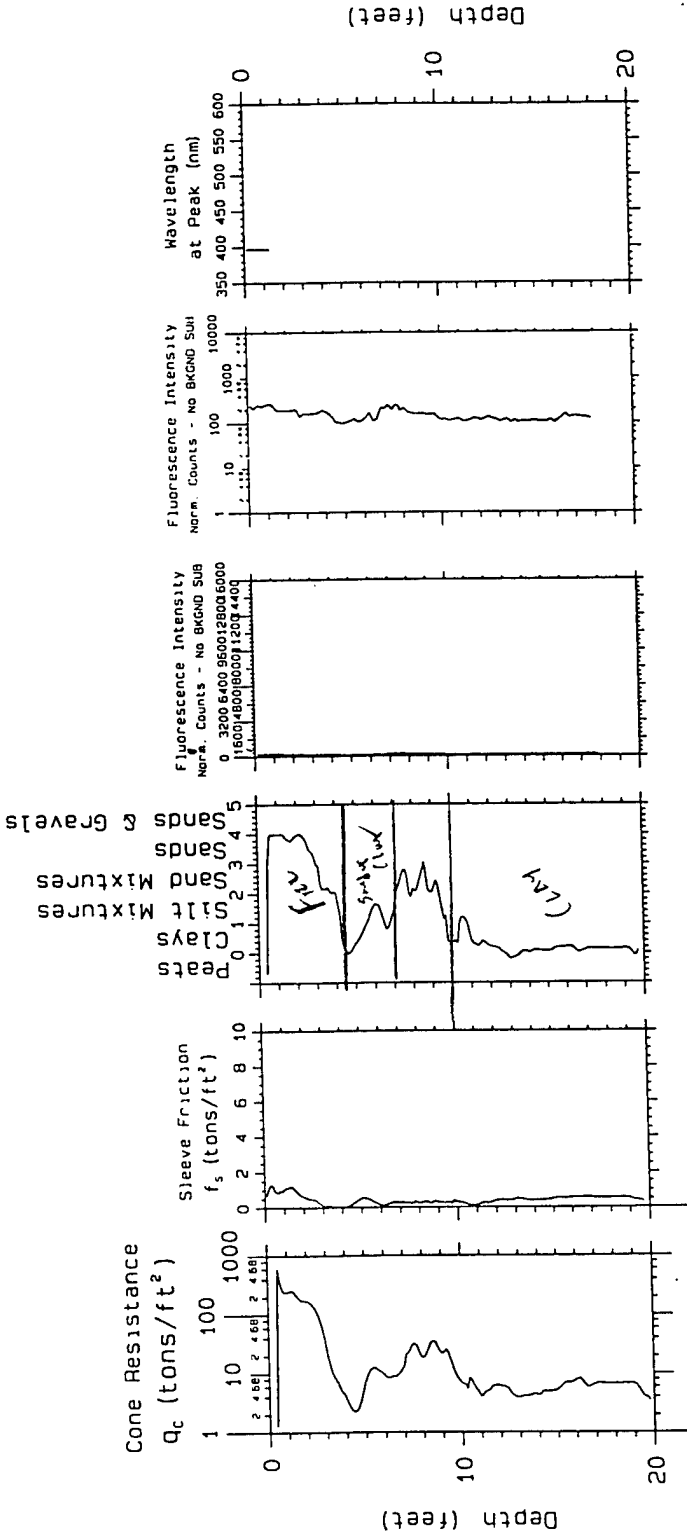

Laser induced fluorescence of PDL via fiber optics

U.S. Army Engineer District Kansas City Geotechnical Branch

Probing date: 03-25-1995

Project; Eaker AFB
Probe Depth; 19.97

SCAPS

Site Characterization and Analysis Penetrometer System

CPT; 20EAK01

CPT based SOIL CLASSIFICATION

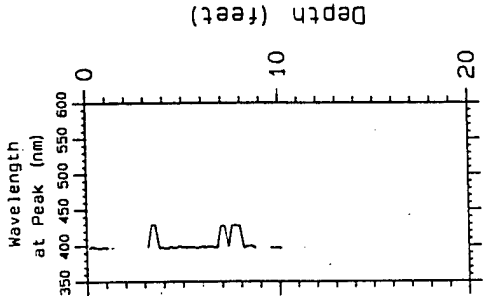
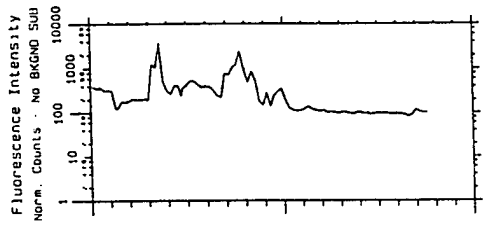
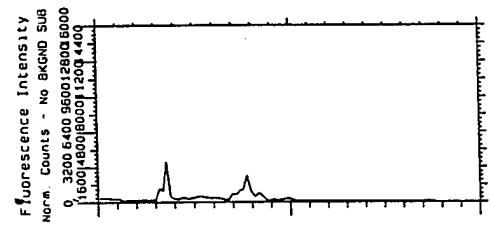
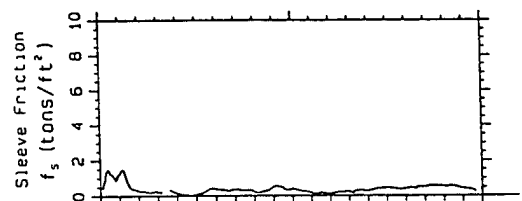
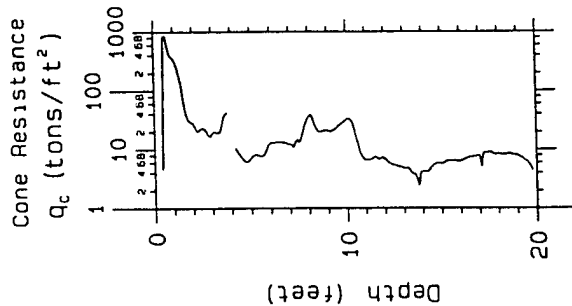
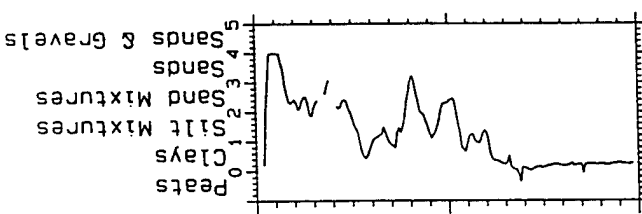

Laser induced fluorescence of POL via fiber optics

U.S. Army Engineer District Kansas City Geotechnical Branch

SCAPS

Site Characterization and Analysis Penetrometer System

CPT; 21EAK01

Project; Eaker AFB
Probe Depth; 19.93

Probing date: 03-25-1995

CPT based SOIL CLASSIFICATION

Clays
Silt Mixtures
Sand
Sand Mixtures
Sands
& Gravels

Cone Resistance
 Q_c (tons/ft²)

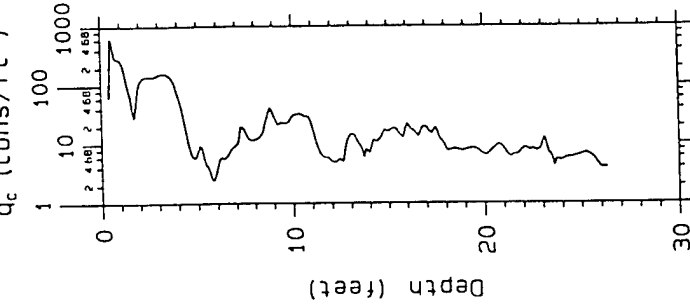

Sleeve Friction
 f_s (tons/ft²)

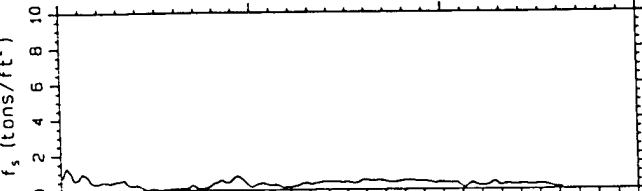

Fluorescence Intensity
Norm. Counts - No BKGD Sub
0 3200 6400 9600 12800 16000

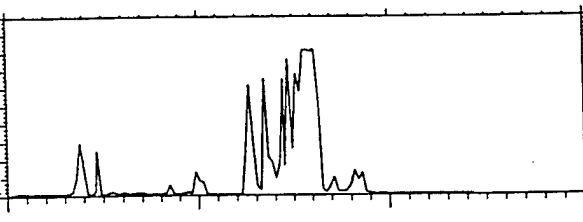

Fluorescence Intensity
Norm. Counts - No BKGD Sub
1 10 100 1000 10000

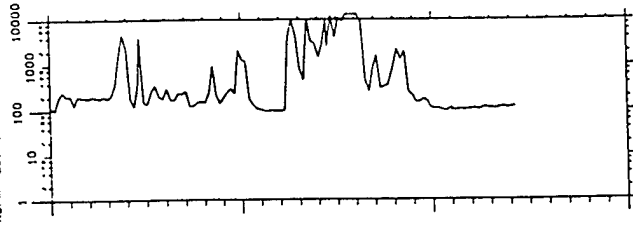

Wavelength
at Peak (nm)

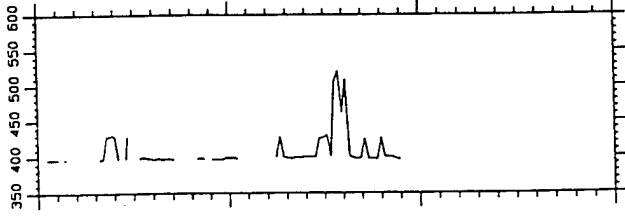

Depth (feet)

Laser induced
fluorescence
of POL via
fiber optics

U.S. Army
Engineer
District
Kansas City

Br

3-25

Pr

Project: Eaker AFB
Probe Depth: 26.46

SCAPS

Site
Characterization
and Analysis
Penetrometer System

CPT; 22EAK01

CPT based SOIL CLASSIFICATION

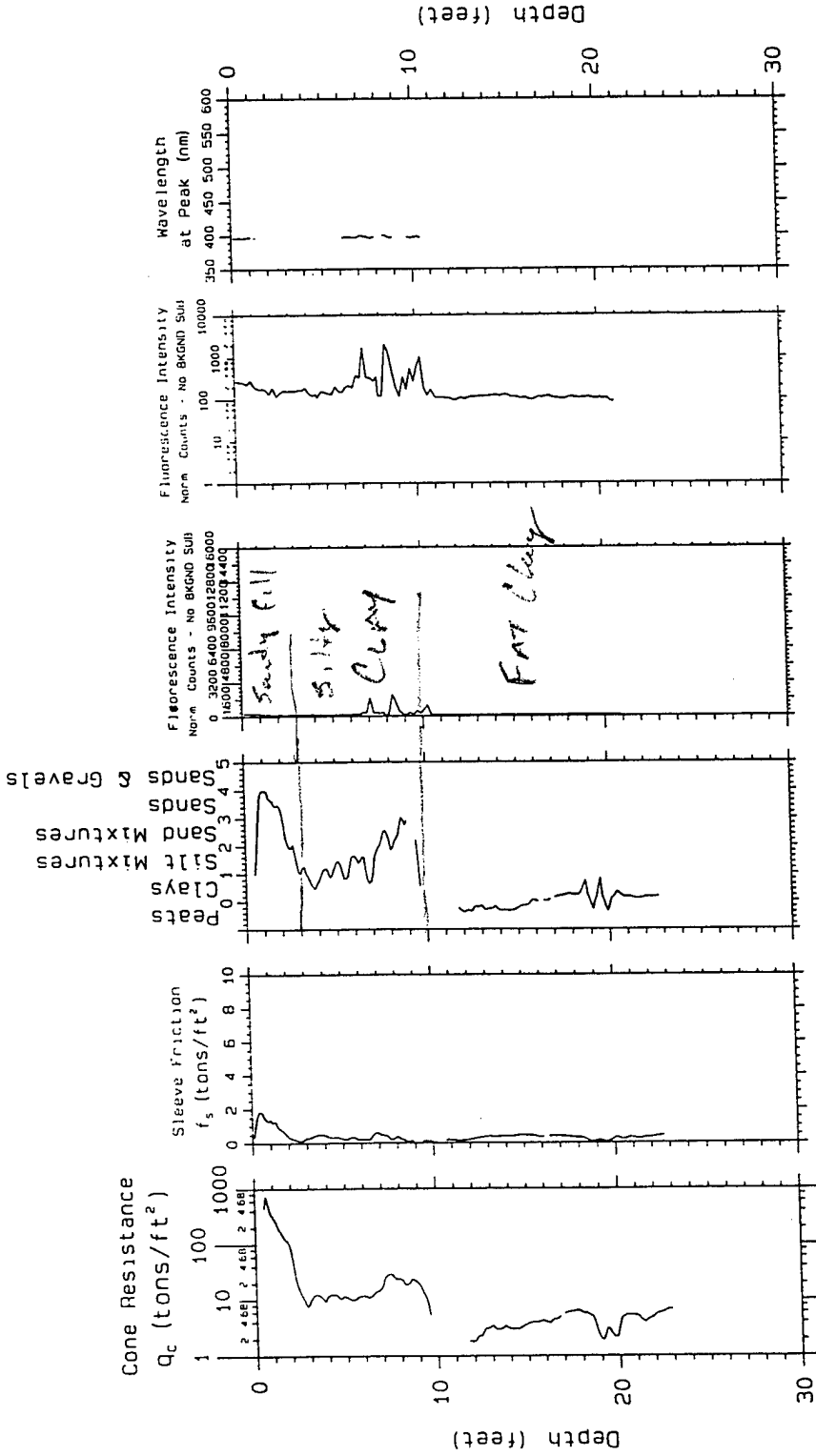

Project; Eaker AFB
 Probe Depth: 23.07

Site Characterization and Analysis Penetrometer System
CPT; 23EAK01



Laser induced fluorescence of POL via fiber optics

U.S. Army Engineer District Kansas City Geotechnical Branch

Probing date: 03-25-1995

CPT based SOIL CLASSIFICATION

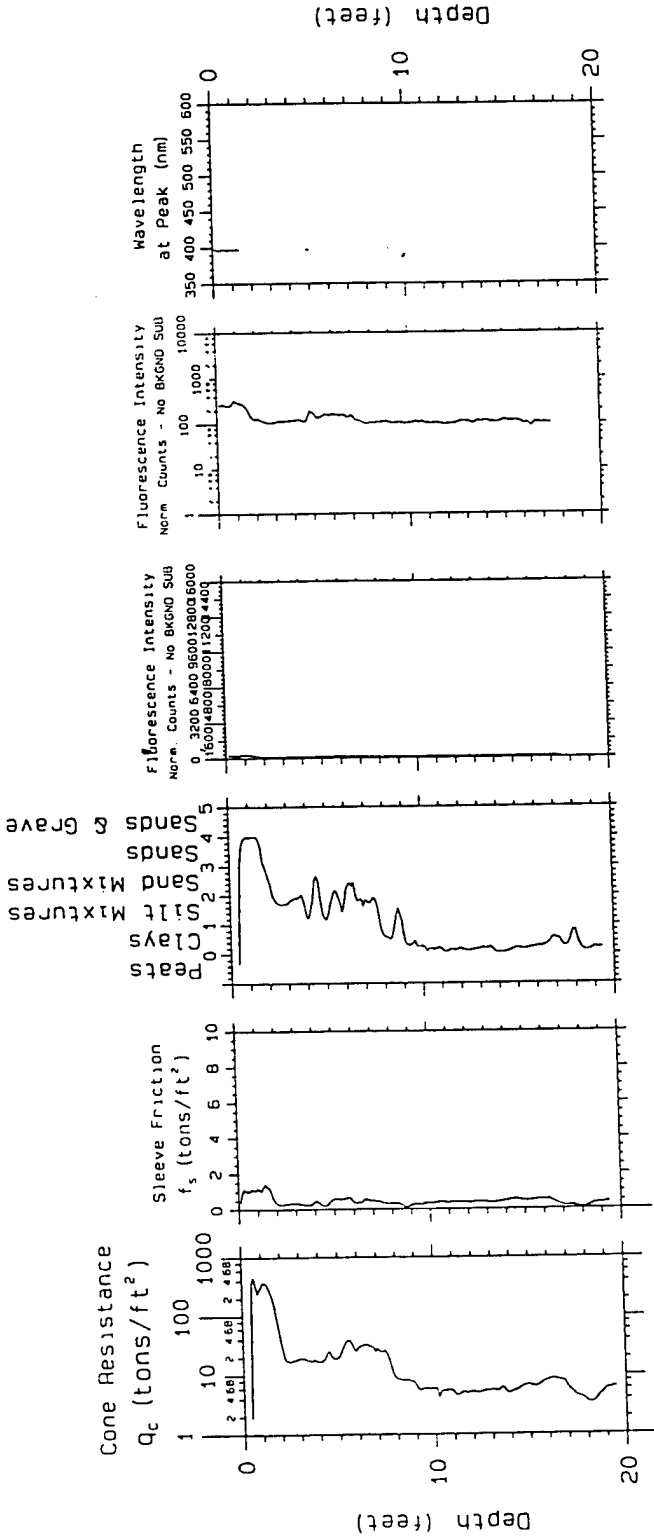

Laser induced fluorescence of POL via fiber optics

U.S. Army Engineer District Kansas City

SCAPS

Site Characterization and Analysis Panstrometer System

CPT: 24EAK01

Project: Eaker AFB
Probe Depth: 19.69

CPT based SOIL CLASSIFICATION

0 T
1 Clays
2 Silt
3 Sand
4 Sand
5 Sands & Gravels

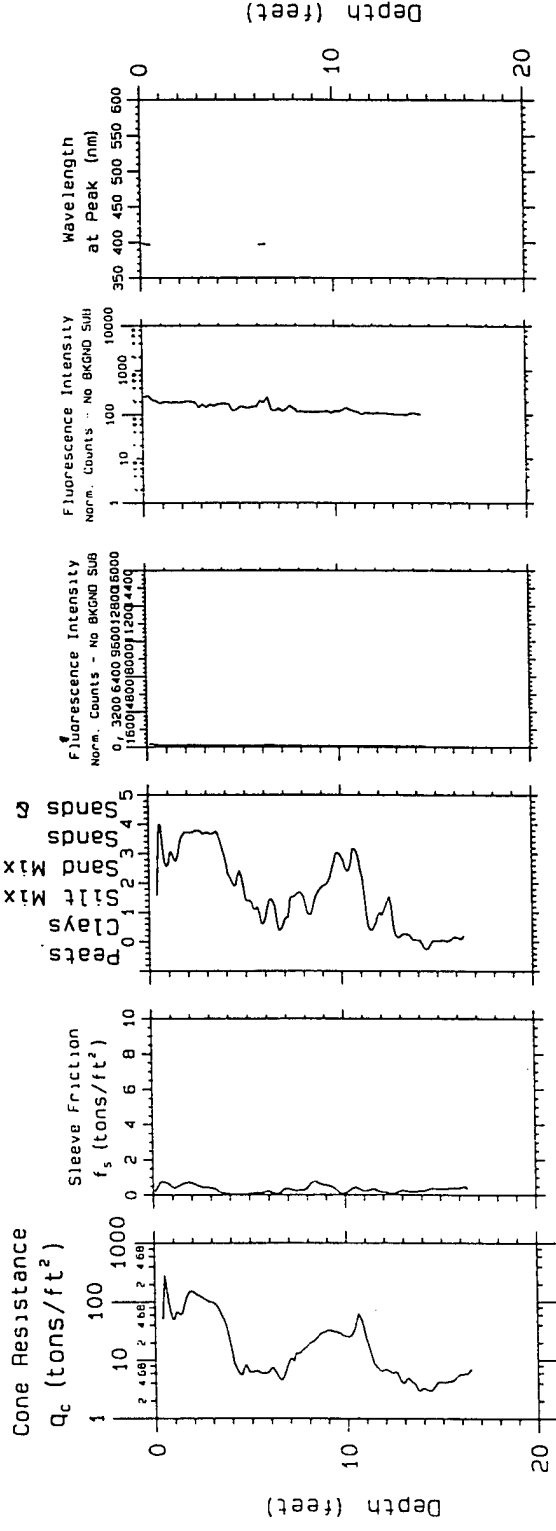

Laser induced
fluorescence
of POL via
fiber optics

U.S. Army
Engineer
District
Kansas City
Geotechnical Branch

SCAPS

Site
Characterization
and Analysis
Penetrometer System

Project; Eaker AFB
Probe Depth: 16.65

CPT; 25EAK01

Probing date: 03-25-1995

CPT based SOIL CLASSIFICATION

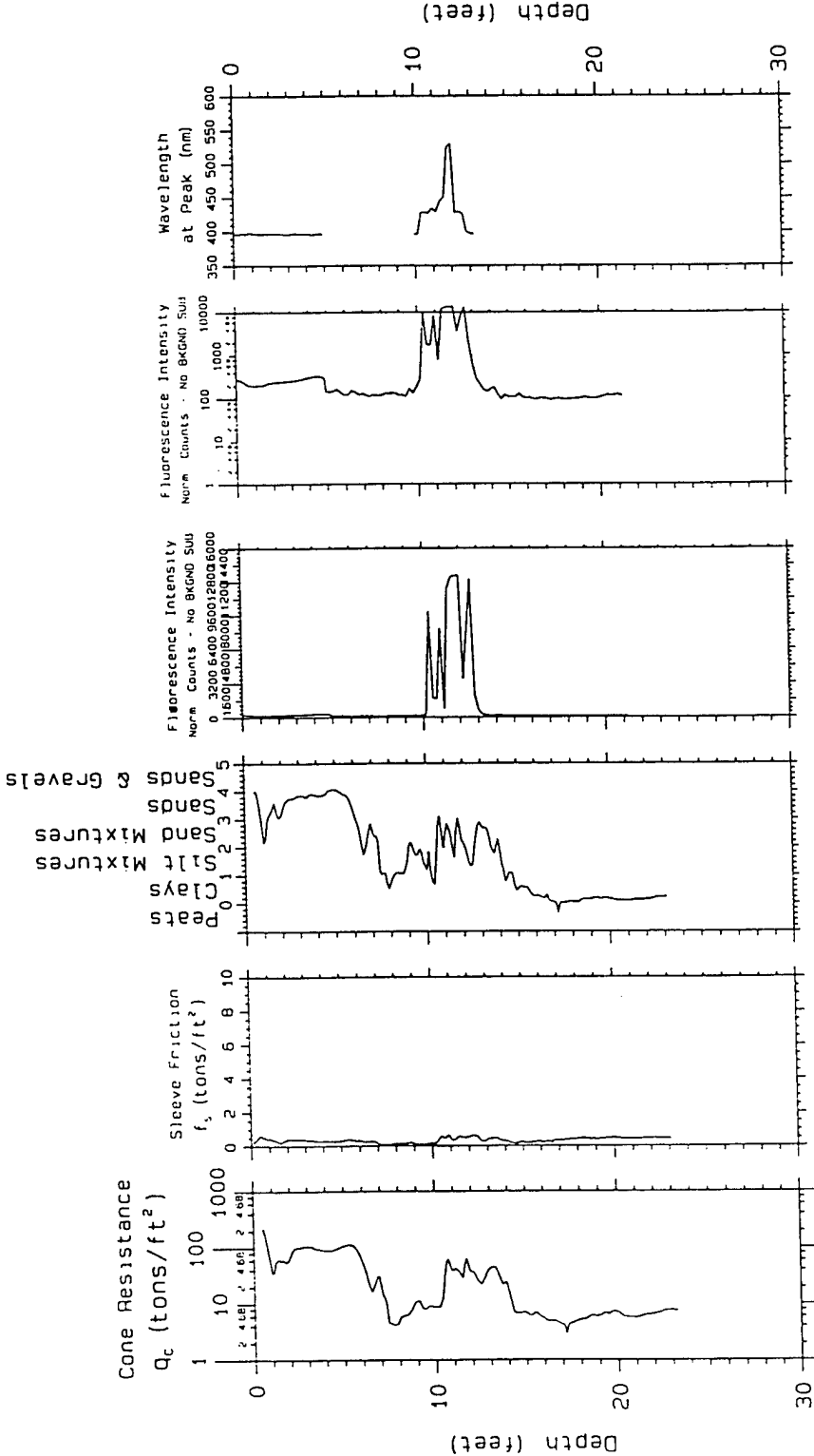

Project; Eaker AFB
 Probe Depth; 23.40

Site Characterization and Analysis Penetrometer System
CPT; 26EAK01



Laser induced fluorescence of POL via fiber optics
 U.S. Army Engineer District Kansas City Geotechnical Branch

Probing date: 03-25-1995

CPT based SOIL CLASSIFICATION

Clays
Silt
Sand
Sands & Gravels

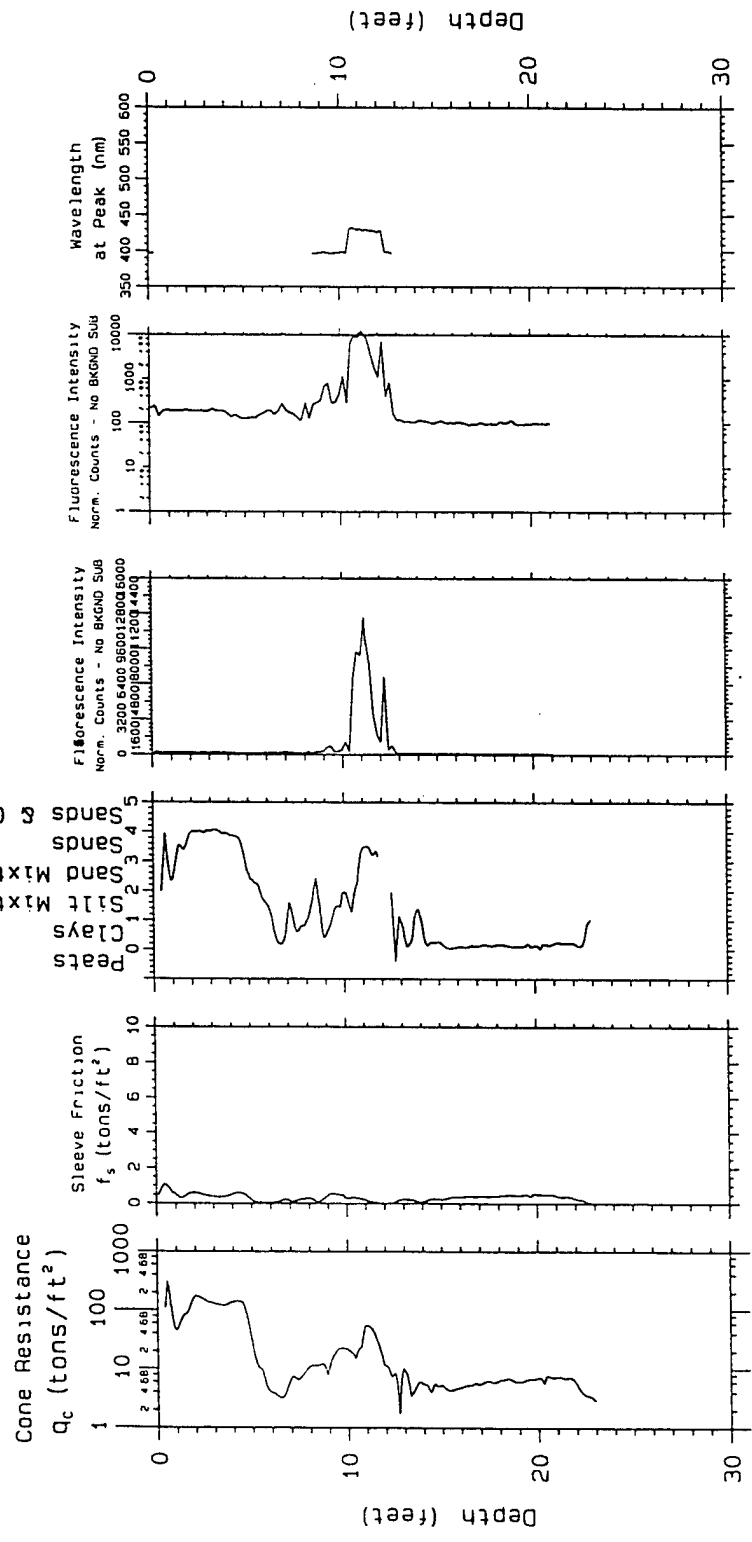

Laser induced fluorescence of POL via fiber optics

U. S. Army Engineer District Kansas City Geotechnical Branch

Project; Eaker AFB
Probe Depth; 23.18

SCAPS

Site Characterization and Analysis Penetrometer System

CPT; 27EAK01

Probing date: 03-25-1995

CPT based SOIL CLASSIFICATION

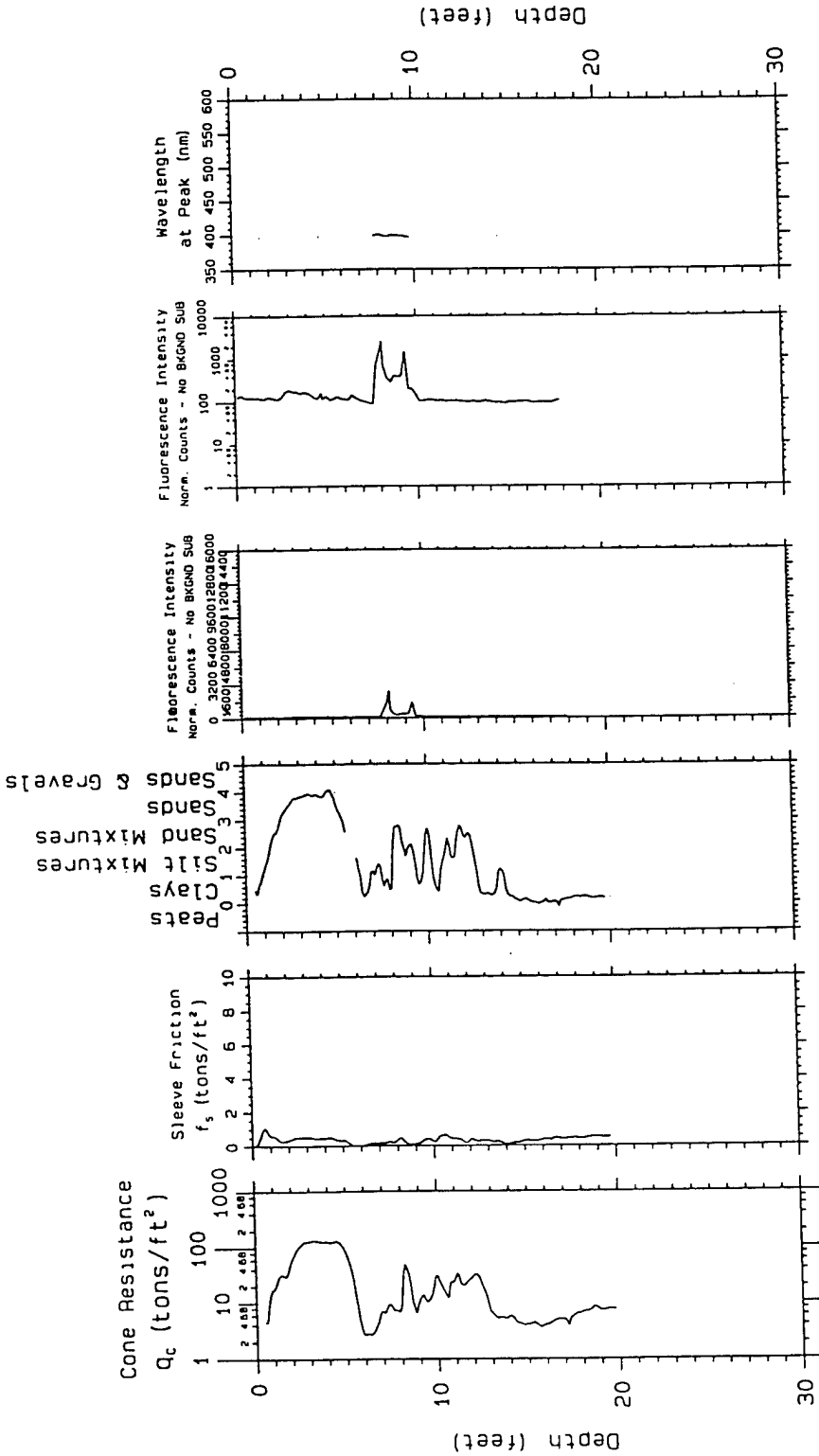

Project; Eaker AFB
 Probe Depth; 20.05

Site Characterization and Analysis Penetrometer System
CPT; 28EAK01

SCAPS

Laser induced fluorescence of POL via fiber optics

U.S. Army Engineer District Kansas City (geotechnical) Branch

CPT based SOIL CLASSIFICATION

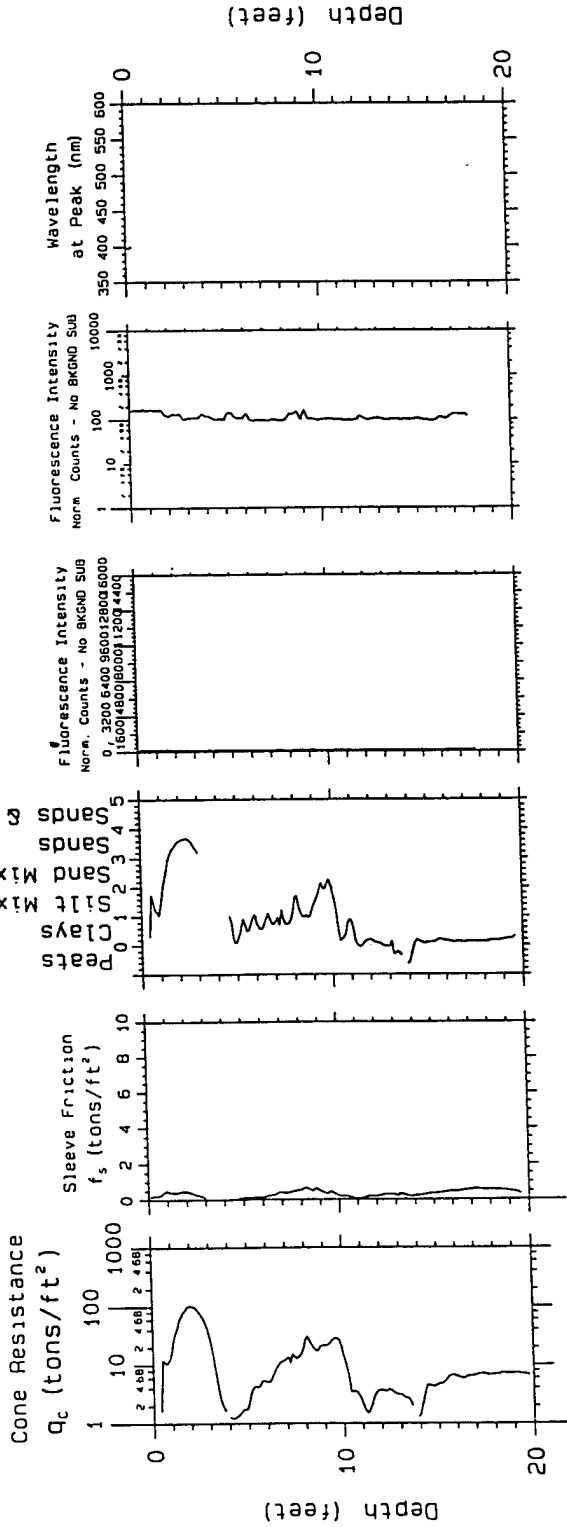

Laser induced fluorescence of POL via fiber optics

U.S. Army Engineer District Kansas City Geotechnical Branch

Probing date: 03-25-1995

SCAPS

Site Characterization and Analysis Penetrometer System

Project; Eaker AFB
Probe Depth; 19.91

CPT; 29EAK01

CPT based SOIL CLASSIFICATION

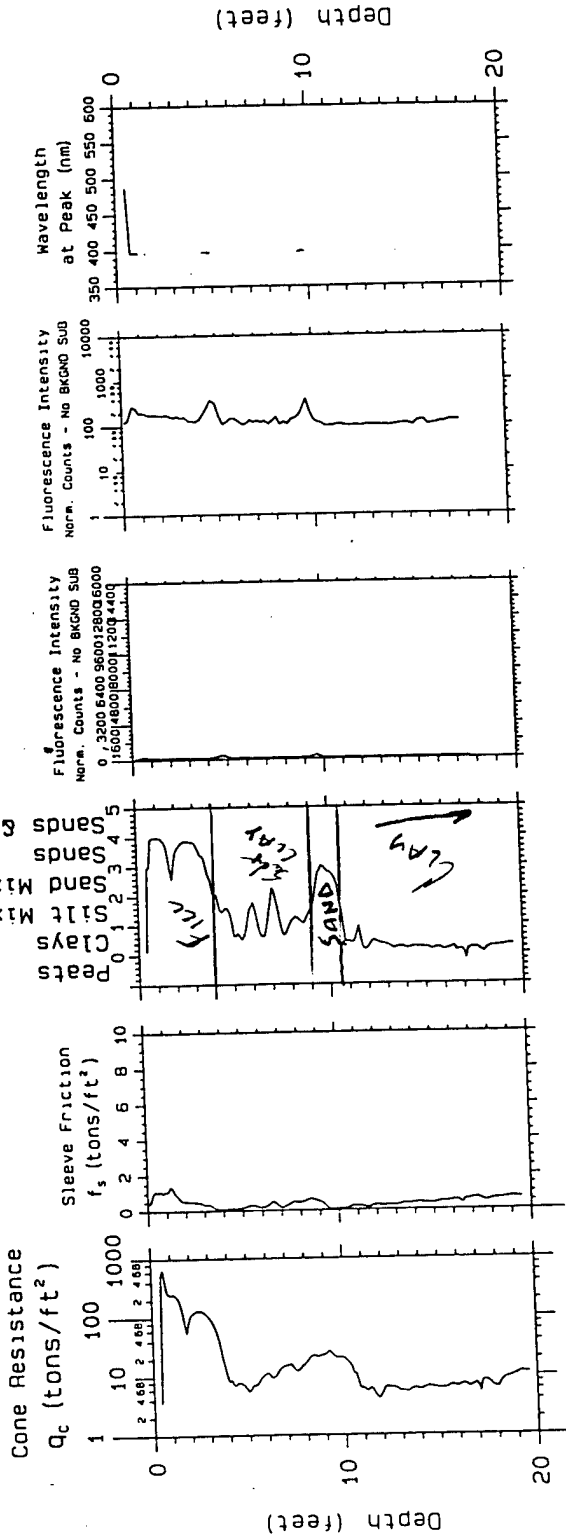

Laser induced fluorescence of POL via fiber optics

U.S. Army Engineer District Kansas City, Mo. Tech. Branch

Plotting date: 03-25-1990

Project; Eaker AFB
Probe Depth; 19.76

Site Characterization and Analysis Penetrometer System
CPT; 30EAK01



CPT based SOIL CLASSIFICATION

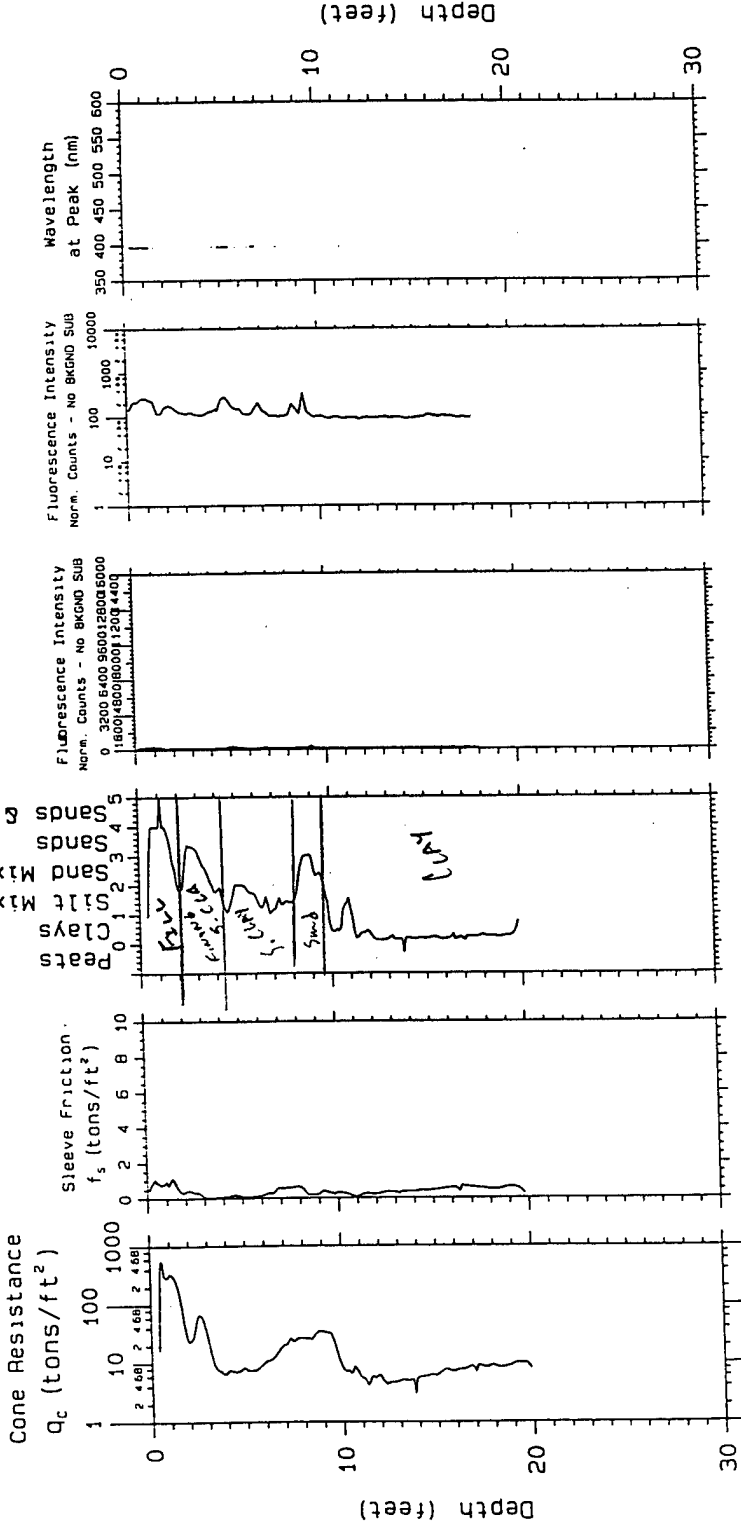

Project; Eaker AFB
 Probe Depth; 20.12

Site Characterization and Analysis Penetrometer System
CPT; 31EAK01



Laser induced fluorescence of PDL via fiber optics

U.S. Army Engineer District Kansas City Geotechnical Branch

Probing date: 03-25-1995