

# NAVAL POSTGRADUATE SCHOOL

## Monterey, California



## THESIS

**MANAGING KNOWLEDGE IN THE BATTLE GROUP THEATER  
TRANSITION PROCESS (BGTP)**

by

Elias Oxendine IV

September 2000

Thesis Advisor:  
Associate Advisor:

Mark E. Nissen  
Carl R. Jones

Approved for public release; distribution unlimited

DTIC QUALITY INSPECTED 4

20001128 072

<b>REPORT DOCUMENTATION PAGE</b>			Form Approved OMB No. 0704-0188	
Public reporting burden for this collection of information is estimated to average 1 hour per response, including the time for reviewing instruction, searching existing data sources, gathering and maintaining the data needed, and completing and reviewing the collection of information. Send comments regarding this burden estimate or any other aspect of this collection of information, including suggestions for reducing this burden, to Washington headquarters Services, Directorate for Information Operations and Reports, 1215 Jefferson Davis Highway, Suite 1204, Arlington, VA 22202-4302, and to the Office of Management and Budget, Paperwork Reduction Project (0704-0188) Washington DC 20503.				
1. AGENCY USE ONLY (Leave blank)		2. REPORT DATE September 2000	3. REPORT TYPE AND DATES COVERED Master's Thesis	
4. TITLE AND SUBTITLE: Managing Knowledge in the Battle Group Theater Transition Process (BGTP)			5. FUNDING NUMBERS	
6. AUTHOR(S) Oxendine, Elias IV				
7. PERFORMING ORGANIZATION NAME(S) AND ADDRESS(ES) Naval Postgraduate School Monterey, CA 93943-5000			8. PERFORMING ORGANIZATION REPORT NUMBER	
9. SPONSORING / MONITORING AGENCY NAME(S) AND ADDRESS(ES) N/A			10. SPONSORING / MONITORING AGENCY REPORT NUMBER	
11. SUPPLEMENTARY NOTES The views expressed in this thesis are those of the author and do not reflect the official policy or position of the Department of Defense or the U.S. Government.				
12a. DISTRIBUTION / AVAILABILITY STATEMENT Approved for public release; distribution is unlimited			12b. DISTRIBUTION CODE	
13. ABSTRACT (maximum 200 words) At a time when theater environments are frequently hostile, changing rapidly, and uncertain, the need to improve the Battle Group Theater Transition Process (BGTP) between carrier battle groups is intense. Recent developments in information technology help facilitate the transition process, but only data and information are transferred at present, not knowledge. This study provides in-depth analysis of the current BGTP being employed by the Department of the Navy (DoN) in the Arabian Gulf. The purpose of this study is to design a knowledge management system that significantly reduces carrier battle group theater familiarization periods. This study builds upon recent work that focuses on knowledge management and system design from three integrated perspectives: 1) reengineering, 2) expert systems knowledge acquisition and representation, and 3) information systems analysis and design. This paper uses an integrated framework for knowledge process and system design. This integrated framework covers the gamut of design considerations from the enterprise process in large, through alternative classes of knowledge in the middle, and on to specific systems in detail. This study applies the integrated framework to the BGTP to improve process performance.				
14. SUBJECT TERMS Analysis and Design, Expert Systems, Information Systems, Knowledge Management, Reengineering, U.S. Navy			15. NUMBER OF PAGES 92	
			16. PRICE CODE	
17. SECURITY CLASSIFICATION OF REPORT Unclassified	18. SECURITY CLASSIFICATION OF THIS PAGE Unclassified	19. SECURITY CLASSIFICATION OF ABSTRACT Unclassified	20. LIMITATION OF ABSTRACT UL	

THIS PAGE INTENTIONALLY LEFT BLANK

Approved for public release; distribution is unlimited

**MANAGING KNOWLEDGE IN THE BATTLE GROUP THEATER  
TRANSITION PROCESS (BGTP)**

Elias Oxendine IV  
Lieutenant, U.S. Navy  
B.S., Norfolk State University, 1993

Submitted in partial fulfillment of the  
requirements for the degree of

**MASTER OF SCIENCE IN INFORMATION TECHNOLOGY MANAGEMENT**

from the

**NAVAL POSTGRADUATE SCHOOL  
September 2000**

Author:



Elias Oxendine IV

Approved by:



Mark E. Nissen, Thesis Advisor



Carl R. Jones, Associate Advisor



Dan Boger, Chairman, Information Systems  
Academic Group

THIS PAGE INTENTIONALLY LEFT BLANK

## ABSTRACT

At a time when theater environments are frequently hostile, changing rapidly, and uncertain, the need to improve the Battle Group Theater Transition Process (BGTP) between carrier battle groups is intense. Recent developments in information technology help facilitate the transition process, but only data and information are transferred at present, not knowledge. This study provides in-depth analysis of the current BGTP being employed by the Department of the Navy (DoN) in the Arabian Gulf. The purpose of this study is to design a knowledge management system that significantly reduces carrier battle group theater familiarization periods. This study builds upon recent work that focuses on knowledge management and system design from three integrated perspectives: 1) reengineering, 2) expert systems knowledge acquisition and representation, and 3) information systems analysis and design. This paper uses an integrated framework for knowledge process and system design. This integrated framework covers the gamut of design considerations from the enterprise process in large, through alternative classes of knowledge in the middle, and on to specific systems in detail. This study applies the integrated framework to the BGTP to improve process performance.

THIS PAGE INTENTIONALLY LEFT BLANK

## TABLE OF CONTENTS

<b>I.</b>	<b>INTRODUCTION.....</b>	<b>1</b>
<b>A.</b>	<b>BACKGROUND .....</b>	<b>1</b>
<b>B.</b>	<b>RESEARCH QUESTIONS.....</b>	<b>3</b>
<b>C.</b>	<b>SCOPE OF THESIS.....</b>	<b>3</b>
<b>D.</b>	<b>RESEARCH METHODOLOGY.....</b>	<b>4</b>
<b>E.</b>	<b>CHAPTER OUTLINE .....</b>	<b>4</b>
<b>II.</b>	<b>BACKGROUND.....</b>	<b>5</b>
<b>A.</b>	<b>KNOWLEDGE .....</b>	<b>5</b>
<b>1.</b>	<b>Knowledge Management (KM) .....</b>	<b>6</b>
<b>2.</b>	<b>Knowledge Hierarchy and Dimensions .....</b>	<b>9</b>
<b>3.</b>	<b>Knowledge Management (KM) Life Cycle.....</b>	<b>11</b>
<b>4.</b>	<b>KM Design Process .....</b>	<b>12</b>
<b>a.</b>	<i>Process Analysis .....</i>	<i>13</i>
<b>b.</b>	<i>Knowledge Analysis.....</i>	<i>13</i>
<b>c.</b>	<i>Context Analysis.....</i>	<i>13</i>
<b>d.</b>	<i>Systems Analysis .....</i>	<i>14</i>
<b>B.</b>	<b>THE CARRIER BATTLE GROUP (CVBG) .....</b>	<b>14</b>
<b>C.</b>	<b>NETWORK-CENTRIC WARFARE (NCW) .....</b>	<b>17</b>
<b>D.</b>	<b>NAVAL INTELLIGENCE COMMUNITY .....</b>	<b>20</b>
<b>E.</b>	<b>SUMMARY .....</b>	<b>22</b>
<b>III.</b>	<b>THE BATTLE GROUP THEATER TRANSITION PROCESS (BGTTP) AT THE PACIFIC FLEET .....</b>	<b>23</b>
<b>A.</b>	<b>THE BATTLE GROUP THEATER TRANSITION PROCESS (BGTTP) .....</b>	<b>23</b>
<b>1.</b>	<b>BGTTP Origin .....</b>	<b>23</b>
<b>2.</b>	<b>BGTTP Purpose.....</b>	<b>24</b>
<b>B.</b>	<b>KNOWLEDGE MANAGEMENT DESIGN PROCESS .....</b>	<b>25</b>
<b>1.</b>	<b>Introduction.....</b>	<b>25</b>
<b>2.</b>	<b>Research.....</b>	<b>25</b>
<b>3.</b>	<b>Process Analysis .....</b>	<b>26</b>
<b>a.</b>	<i>Identify the Target Process .....</i>	<i>28</i>
<b>b.</b>	<i>Model the Process.....</i>	<i>30</i>
<b>c.</b>	<i>Configuration Measurements and Diagnosis.....</i>	<i>32</i>
<b>4.</b>	<b>Knowledge Analysis.....</b>	<b>34</b>
<b>5.</b>	<b>Context Analysis.....</b>	<b>36</b>
<b>6.</b>	<b>Systems Analysis .....</b>	<b>37</b>
<b>C.</b>	<b>SUMMARY .....</b>	<b>38</b>

<b>IV.</b>	<b>INNOVATING KNOWLEDGE MANAGEMENT AT THE PACIFIC FLEET .....</b>	<b>39</b>
<b>A.</b>	<b>PROCESS DESIGN.....</b>	<b>39</b>
<b>1.</b>	<b>Match Transformations.....</b>	<b>40</b>
<b>2.</b>	<b>Generate Redesign Alternatives .....</b>	<b>43</b>
<b>a.</b>	<i>Alternative One: Knowledge Repositories.....</i>	<i>44</i>
<b>b.</b>	<i>Alternative Two: Knowledge-based Systems .....</i>	<i>47</i>
<b>3.</b>	<b>Test Alternatives .....</b>	<b>54</b>
<b>4.</b>	<b>Select Solution .....</b>	<b>54</b>
<b>5.</b>	<b>Redesign Implementation.....</b>	<b>57</b>
<b>B.</b>	<b>KNOWLEDGE PERFORMANCE MEASURES.....</b>	<b>59</b>
<b>C.</b>	<b>KNOWLEDGE MANAGEMENT IN NETWORK-CENTRIC WARFARE (NCW) .....</b>	<b>61</b>
<b>D.</b>	<b>SUMMARY .....</b>	<b>62</b>
<b>V.</b>	<b>CONCLUSIONS AND RECOMMENDATIONS.....</b>	<b>65</b>
<b>A.</b>	<b>SUMMARY .....</b>	<b>65</b>
<b>B.</b>	<b>CONCLUSIONS .....</b>	<b>66</b>
<b>C.</b>	<b>RECOMMENDATIONS.....</b>	<b>67</b>
<b>D.</b>	<b>FUTURE RESEARCH.....</b>	<b>68</b>
<b>1.</b>	<b>Other BGTTP KM Applications .....</b>	<b>68</b>
<b>2.</b>	<b>Other KM Applications.....</b>	<b>69</b>
<b>E.</b>	<b>FINAL THOUGHTS .....</b>	<b>69</b>
	<b>LIST OF REFERENCES.....</b>	<b>71</b>
	<b>INITIAL DISTRIBUTION .....</b>	<b>73</b>

## LIST OF FIGURES

Figure 2.1	Evolution of Knowledge Management Integrating Intellectual Capital .....	7
Figure 2.2	Evolution of Knowledge .....	10
Figure 2.3	CVBG Command and Control Organizational Chart .....	17
Figure 2.4	NCW Logical Model.....	19
Figure 2.5	NCW Warfighting Value Chain.....	19
Figure 2.6	Intelligence Cycle .....	22
Figure 3.1	USCENTCOM Area of Responsibility.....	23
Figure 3.2	General Redesign Process.....	27
Figure 3.3	Knowledge Capture and Transfer between Battle Groups .....	30
Figure 3.4	Intelligence Cycle Model.....	31
Figure 4.1	Intelligence Cycle Model.....	42
Figure 4.2	Key Dimensions of Knowledge Management Tools.....	43
Figure 4.3	Redesign Alternative 1: Groupware.....	48
Figure 4.4	Applying AI Concepts with a Computer .....	49
Figure 4.5	General Block Diagram of an Expert System.....	50
Figure 4.6	Redesign Alternative 2: Expert System .....	51
Figure 4.7	Agent Interacting with Environment through Sensors and Effectors .....	52
Figure 4.8	Redesign Alternative 2: Intelligent Agent .....	53
Figure 4.9	NCW Warfighting Value Chain.....	61
Figure 4.10	Knowledge Capture and Transfer between Warfare Commanders in the NCW Warfighting Value Chain.....	62

THIS PAGE INTENTIONALLY LEFT BLANK

## LIST OF TABLES

Table 2.1	KM Definitions .....	6
Table 2.2	KM Life Cycle Models .....	11
Table 2.3	Standard CVBG Composition.....	16
Table 3.1	Common Research Themes .....	26
Table 3.2	Process Input Measurements.....	33
Table 3.3	KOPeR Diagnosis .....	34
Table 3.4	Mission Objectives and Critical Success Factors .....	35
Table 3.5	Current BGTPP Methods.....	37
Table 4.1	Redesign Transformations .....	40
Table 4.2	KOPeR Comparitive Measure .....	55

THIS PAGE INTENTIONALLY LEFT BLANK

## ACKNOWLEDGMENTS

I would like to thank the U.S. Navy for providing me the opportunity to attend the Naval Postgraduate School. I would like to thank Dr. Nissen and Dr. Jones for overseeing my research study of this topic. Additionally, I would like to thank the Network Centric Innovation Center (NCIC) for providing the topic and funding my research. Finally, I would like to thank my family, Miko and Elias, for their support and understanding during my career and studies.

THIS PAGE INTENTIONALLY LEFT BLANK

## I. INTRODUCTION

Chapter I discusses the purpose and content of this thesis. It also provides a brief overview of the background and objectives of the research, questions answered, and the methodology used.

### A. BACKGROUND

As the United States Navy continues to support the naval strategic concept *Forward...From the Sea* into the twenty-first century, one of the Navy's primary responsibilities is to maintain a forward presence throughout the world and project power to possibly deter any action(s) that may threaten U.S. interests. In order to support this objective, the Department of the Navy (DoN) maintains naval forces abroad and periodically deploys ships throughout the high seas to protect U.S. interests. By doing so, the DoN has always used the carrier battle group (CVBG) as an instrument for power projection and forward presence.

The CVBG is a combat formation of ships and aircraft, which comprises a principal element of U.S. national power projection capability. It is the essential foundation of U.S. ability to conduct operations envisioned in *Forward...From the Sea*. The CVBG includes capabilities sufficient to accomplish a variety of combat tasks in war, and it serves a wide variety of functions in situations short of war. The CVBG's peacetime mission is to conduct forward presence operations to help shape the strategic environment by deterring conflict, building interoperability, and by responding, as necessary, to fast breaking crises with the demonstration and application of credible combat power (OPNAV Instruction 3501.316 1995).

In order to support this peacetime objective, the DoN conducts and maintains periodic CVBG deployments in theaters of U.S. interests (e.g., the Arabian Gulf). Typically, a CVBG remains on station for three months. After three months on station, the CVBG personnel, equipment, and support are relieved by another CVBG, which conducts a successive, three-month deployment in theater.

The transition from one CVBG to another in theater is facilitated by the Battle Group Theater Transition Process (BGTTP). The primary objective of this process is to capture and transfer knowledge between CVBGs so as to reduce the arriving battle group's (BG) theater familiarization period. The familiarization period is the time it takes for the arriving BG to become acclimated to the new environment (e.g., understanding the nature and seriousness of regional threats). During each familiarization period, the arriving BG is at some risk in terms of effectively responding to any indications and warnings (I & W) and engaging a potential threat accordingly if the immediate need arises. The current theater turnover process conducted between CVBGs provides the arriving BG with explicit, theater, background information, but the experience and tacit knowledge gained through theater operations by the departing BG may not be transferred during the process.

At a time when theater environments are frequently hostile, changing rapidly, and uncertain, the need to decrease CVBG theater familiarization periods is intense. Recent developments in information technology (IT) help facilitate the transition process, but only data and information are transferred at present, not knowledge. If the arriving BG is to effectively conduct its peacetime and wartime missions, it must possess as much knowledge of the theater it is operating in as the departing BG, the latter of which has

been on station for three months. Applying knowledge management (KM) to the BGTTP, this thesis seeks to decrease BG theater familiarization periods.

The goal of this research is to significantly reduce the theater familiarization period of CVBGs, by applying KM process analysis to the BGTTP. The primary objective for an ideal turnover is for the arriving BG to perform, on day one of operations in theater, as if it were on the departing BG's 90th day of operations in theater.

## **B. RESEARCH QUESTIONS**

This research is focused on answering a primary question "How can knowledge management be implemented to improve the BGTTP?" In order to answer this question, several subsidiary questions must be addressed.

- What is knowledge management?
- What is BGTTP?
- What knowledge is needed? When? By whom?
- What is the knowledge differential between departing and arriving CVBGs?
- How can the required BGTTP knowledge be effectively captured, distributed and applied?
- What measures of performance are required to evaluate successful knowledge transfer?
- What migration strategy is required to implement knowledge management for BGTTP?

## **C. SCOPE OF THESIS**

The scope of this thesis includes an overview of the current BGTTP, and knowledge management, as well as analysis of knowledge management potential for

improvement to the BGTTP in the Navy. In particular, the thesis focuses on the U.S. Navy BGTTP currently performed in the Arabian Gulf, and its recommendations are limited to IT that is presently available in the fleet, used in industry or very well developed in the laboratory. Alternatively, KM recommendations are in no way limited to IT solutions, an organizational structure, workflow, doctrine, tactics, human resources, and other factors are experienced as well.

#### **D. RESEARCH METHODOLOGY**

The research techniques used for this thesis include a thorough literature review of knowledge management. A review of Carrier Battle Group Policy and theater operational orders (OPORDs) is performed, semi-structured interviews are conducted with both departing and arriving BG staffs, and one or more specific processes is selected, with KM implications, for detailed analysis. A KM framework is used to analyze and redesign the transfer of knowledge between departing and arriving CVBGs. Both an implementation plan and knowledge performance transfer measures are developed.

#### **E. CHAPTER OUTLINE**

This thesis is organized as follows. Chapter II provides background information on KM, the CVBG mission and responsibilities, Network-Centric Warfare, and naval intelligence. Chapter III discusses the BGTTP in the Navy's Pacific Fleet (PACFLT). Chapter IV innovates the BGTTP in PACFLT through KM. Chapter V closes with conclusions, recommendations, and future research topics.

## II. BACKGROUND

Chapter II provides background information on knowledge management (KM), the carrier battle group (CVBG), Network-Centric Warfare (NCW), and naval intelligence.

### A. KNOWLEDGE

Within the past decade, the increasing need to manage corporate knowledge becomes evident as enterprises compete in the new, global economy. To help motivate the importance of knowledge, Nissen, Sengupta, and Kamel (2000) state:

The power of knowledge has long been ascribed to successful individuals in the organization, but today it is recognized and pursued at the enterprise level through a practice known as KM (see Davenport and Prusak 1998). Although KM has been investigated in the context of decision support systems (DSS) and expert systems (ES) for over a decade (e.g., see Shen 1987), interest in and attention to this topic have exploded recently. For example, knowledge capital is commonly discussed as a factor of no less importance than the traditional economic inputs of labor and finance (Forbes 1997), and the concept of *knowledge equity* is now receiving theoretical treatment through research (e.g., see Glazer 1998).

In this century, knowledge and KM will be the biggest challenge to enterprises competing in the global economy. Enterprises must manage corporate knowledge to be successful in today's and tomorrow's market. Knowledge generates innovation. Through innovation, an enterprise obtains a competitive edge (Davenport and Prusak 1998, Brooking 1999).

The same rationale used to justify KM in commercial enterprises is applicable to the Department of the Navy (DoN). As the DoN relies on information technology (IT) to support naval operations (e.g., Network-Centric Warfare (NCW), Joint Vision 2010, carrier battle group operations) via computer networks, these networks create a potential infrastructure for knowledge exchange and KM opportunities. Furthermore, attrition and

turnover rates are high as service members separate or retire from military service and routinely rotate from billet to billet (i.e., job to job). The potential for knowledge loss is great in either case. The DoN's size and geographic dispersion make it difficult to locate existing knowledge and transfer it to where it is needed in a timely manner. To effectively build the "Navy After Next," which relies highly on IT, the DoN must employ KM because IT cannot provide experience, skill, and adaptability of human expertise.

### 1. Knowledge Management (KM)

Currently, KM is a hot topic in the business world as enterprises rush to understand and employ this new management discipline. Similarly, many practitioners in different disciplines have become active partners in embracing this new field. Because KM is a new discipline, the degree of interest, the view, and the interpretation of KM varies among practitioners, depends on their environment and are reflected in their professional literatures and in the content of professional conventions (Srikantaiah and Koenig 1999). For many KM researchers and practitioners, the definitions of KM, Table 2.1, vary but share some similarities.

Practitioner	KM Definition
Wiig	Systematic, explicit, and deliberate building, renewal, and application of knowledge to maximize an enterprise's knowledge-related effectiveness and returns from its knowledge assets.
Petrash	Getting the right knowledge to the right people at the right time so they can make the best decision.
Macintosh	Identification and analysis of available and required knowledge, and the subsequent planning and control of actions to develop knowledge assets so as to fulfil organization objectives.
Beckman	Formalization of and access to experience, knowledge, expertise that create new capabilities, enable superior performance, encourage innovation, and enhance customer value.

**Table 2.1 KM Definitions (From Leibowitz 1999)**

Within the past decade, why has KM become the hot topic in the business world and the most sought after management discipline? Knowledge is not new and has been around for centuries (Davenport and Prusak 1998, Brooking 1999). Over the years, corporations have tried new initiatives to improve productivity and effectiveness (e.g., database management systems (DBMS), management information systems (MIS), decision support systems (DSS), business process reengineering (BPR). Each initiative flourished at its respective time but no longer provides a significant, competitive advantage in the global economy. Now, experts of those former initiatives are developing new initiatives directed at integrating intellectual capital and social capital (tacit knowledge) with those areas, and frequently marketing the new products as knowledge management systems (KMS), Figure 2.1, (Srikantaiah and Koenig 1999).

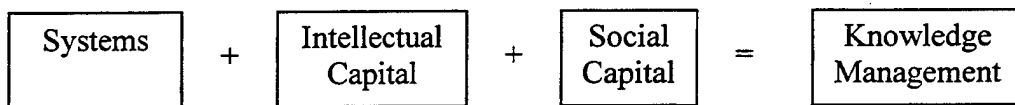

**Figure 2.1 Evolution of Knowledge Management Integrating Intellectual Capital (From Srikantaiah and Koenig 1999)**

Tom Short of IBM summarizes and identifies the reasons organizations employ KM into four categories. KM is introduced to enhance collaboration, to improve productivity, to enable and encourage innovation, and to cope with information overload and deliver only the essentials (Srikantaiah and Koenig 1999, Brooking 1999). Two of those reasons are “means” towards ends (i.e., enhancing collaborations and coping with information overload). The other two are “ends” to those means (i.e., improving productivity and enabling innovation (see Hibbard 1997).

At the turn of the 21<sup>st</sup> century, IT continues to change the way enterprises conduct business at an alarming rate. Some enterprises make the wrong assumption, figuring that IT alone can provide a competitive advantage. However, IT provides a temporary competitive advantage only. Alan Webber defines it as the “self-canceling technological advantage” (Webber 1993). Essentially, the same technology is available to everyone and provides no long-term advantage. Competitors can quickly duplicate most products and services. However, knowledge can provide a sustainable advantage. The knowledge advantage is sustainable, because it generates increasing returns and continuing advantages. Unlike material assets, knowledge assets increase with use (Davenport and Prusak 1998). Despite technological developments and advances, KM is critical for business survival and success.

Drawing from Davenport and Prusak, in a new global economy, knowledge may be a company’s greatest competitive advantage. Companies can no longer rely on outdated business practices for survival in the future. As global competition increases, companies will require quality, value, service, innovation, and speed to market for business success, and these factors will be even more critical in the future. Essentially, companies will differentiate themselves on the basis of what they know (Davenport and Prusak 1998).

Although KM is the latest management discipline, many are discovering that managing corporate knowledge is difficult (Davenport 1995). First, important or key knowledge is tacit and unstructured (Nonaka 1994), which prevents knowledge acquisition and application. Second, Ruggles (1997) notes IT employed to enable knowledge work targets data and information, not knowledge. Nissen, Kamel, and

Sengupta (2000) feel this contributes to difficulties experienced with KM to date. By definition, knowledge is distinct from data and information (Davenport et al. 1998, Nonaka 1994, Teece 1998, Nissen, Kamel, & Sengupta 2000).

## **2. Knowledge Hierarchy and Dimensions**

To fully understand KM, the knowledge hierarchy and knowledge dimensions must be defined and explained first. The knowledge hierarchy is comprised of data, information, and knowledge. Davenport and Prusak provide definitions for each. Data is defined as a set of discrete, objective facts and events (e.g., text, numbers, etc.) and has no meaning. In an organizational context, data is most usefully described as structured records of transaction. Peter Drucker states that information is “data endowed with relevance and purpose,” which suggests that data by itself has little relevance or purpose (Davenport and Prusak 1998).

Information is a message, usually in the form of a document or an audible or visible communication, and has meaning. As with any message, it has a sender and receiver. Information is data that makes a difference and is meant to change the way the receiver perceives something, to have an impact on his judgement or behavior. The receiver, not the sender, decides whether the message he gets is really information—that is, if it truly informs him (Davenport and Prusak 1998).

Davenport and Prusak provide a working definition of knowledge since defining knowledge explicitly is difficult and challenging. “Knowledge is a fluid mix of framed experience, values, contextual information, and expert insight that provides a framework for evaluating and incorporating new experiences and information” (Davenport and Prusak 1998, p. 5). Knowledge is intuitive and difficult to explain to others. Knowledge

is transferred through structured media such as books and documents, and person-to-person contacts ranging from conversations to apprenticeships.

Figure 2.2, a combination of Tobin and Atler's perspectives on knowledge evolution, outlines the transformation of data to knowledge. All organizations need, collect, and store data. Data becomes information when its creator adds value or meaning (Davenport and Prusak 1998, Alter 1996, Tobin 1996). Information becomes knowledge when an action or application occurs. Knowledge derives from information as information derives from data.

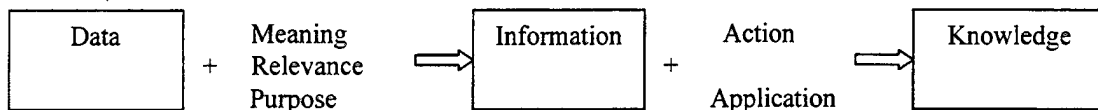

**Figure 2.2 Evolution of Knowledge (From Tobin 1996 and Atler 1996)**

Knowledge in organizations ranges from the complex, accumulated expertise of individuals, which is partly or largely inexpressible, to much more structured and explicit content (Davenport and Prusak 1998). There are two dimensions around which knowledge can be characterized: explicit and tacit. Explicit knowledge is formal, documented knowledge that is readily accessible. Some examples of explicit knowledge are found in commercial publications, organizational business records, email, messages, documents, Web, groupware, Intranets, databases, and self-study materials, among others.

Tacit knowledge is informal, accessible only through knowledge elicitation and observation of behavior (Liebowitz 1999). It is developed and internalized by the knower over a long period of time and almost impossible to reproduce in a document or database (Davenport and Prusak 1998). Some examples of tacit knowledge are reflected in face-

to-face conversations, both formal and informal, telephone conversations, both formal and informal, the knowledge that individuals possess in their heads, as well as in their desk drawers and file cabinets.

### 3. KM Life Cycle

In the KM literature, there are several KM life cycles (KMLC). Table 2.2 outlines KM life cycles proposed by several researchers (Nissen 1999, Despres and Chauvel 1999, Gartner Group 1999, Davenport and Prusak 1998). The four models share considerable similarities. Using the amalgamated model, the phases in the KM life cycle are create, capture, organize, formalize, distribute, apply and evolve. Phase 1,

<u>Model</u>	<u>Phase 1</u>	<u>Phase 2</u>	<u>Phase 3</u>	<u>Phase 4</u>	<u>Phase 5</u>	<u>Phase 6</u>
<b>Nissen</b>	Capture	Organize	Formalize	Distribute	Apply	
<b>Despres and Chauvel</b>	Create	Map Or Bundle	Store	Share Or Transfer	Reuse	Evolve
<b>Gartner Group</b>	Create	Organize	Capture	Access	Use	
<b>Davenport And Prusak</b>	Generate		Codify	Transfer		
<b>Amalgamated</b>	Create	Organize	Formalize	Distribute	Apply	Evolve

**Table 2.2 KM Life Cycle Models (From Nissen, Kamel, & Sengupta 2000)**

*create*, involves discovery and the development of new knowledge (Despres and Chauvel 1999, Gartner Group 1999). Phase 2, *organize*, pertains to the organization, mapping or bundling of knowledge (Nissen 1999, Gartner Group 1999). Phase 3, *formalize*,

involves transforming organizational knowledge into explicit form. Phase 4, *distribute*, is the distribution or sharing of knowledge in the enterprise. Phase 5, *apply*, requires the application or use of knowledge for problem solving or decision making in the organization (Nissen 1999). Phase 6, *evolve*, is the refinement and continued development of existing knowledge (Despres and Chauvel 1999).

#### **4. KM Design Process**

As KM continues to emerge as a new discipline, Nissen, Kamel, and Sengupta note the integration of knowledge process design with knowledge system design is absent from KM literature and practice (Nissen, Kamel, & Sengupta 2000). They focus on KM and system analysis from three integrated perspectives: 1) reengineering process innovation, 2) expert systems knowledge acquisition and representation, and 3) information systems analysis and design. They integrate the three perspectives in a systematic manner, beginning with analysis and design of the enterprise process of interest, progressively moving into knowledge capture and formalization, and then system design and implementation. Explicitly, the steps in the Nissen, Kamel, and Sengupta KM design process are: 1) process analysis, 2) knowledge analysis, 3) context analysis, and 4) system analysis. By using this integrated methodology, one can see how to identify, select, compose and integrate the many component applications and technologies required for effective knowledge system and process design (Nissen, Kamel, & Sengupta 2000).

*a. Process Analysis*

The first stage, process analysis, requires understanding the objectives and strategies of an enterprise and generally entails process modeling and analysis that results in one or more (re)designs for the process in question. The process, along with its various redesign opportunities and required knowledge, must be understood first before designing systems. Although many methodologies have been developed for process (re)design, this thesis uses Nissen's measurement-driven redesign knowledge system, KOPeR, which automatically diagnoses process pathologies and recommends redesign transformations (Nissen, Sengupta & Kamel 2000).

*b. Knowledge Analysis*

Knowledge analysis is mutually dependent on process analysis and directly fed by the process analysis results (Nissen, Kamel, & Sengupta 2000). Prior to conducting knowledge analysis, the organization's mission and goal must be fully understood. Knowledge analysis involves identifying key knowledge within an organization. Knowledge analysis results in a thorough understanding of critical success factors (CSF) and identifies the key explicit and tacit knowledge employed to make decisions and take action. CSFs are those few key factors that must go well in order for the mission to succeed and goals to be achieved.

*c. Context Analysis*

Context analysis focuses on the context surrounding two primary factors, the organization and the knowledge underlying the task (Nissen, Kamel, & Sengupta 2000). In addressing contextual factors associated with the organization, the role of organizational memory, its structure, and organizational incentives are the focus.

Regarding the task-related knowledge, the practices organizations employ to codify, or make explicit, is the focus.

*d. Systems Analysis*

During system analysis, the organization's current procedures and information systems used to perform organizational tasks are analyzed. The system analysis phase is identical to the analysis and design phases of the system development life cycle (SDLC). During the analysis phase, system requirements are determined principally from the steps above, and an alternate system design(s) is derived to match the system requirements. The output of the analysis phase is a description of the alternative solution. During the design phase, the description of the new or enhanced system is designed meeting the new system requirements (Hoffer, George & Valacich 1998).

**B. THE CARRIER BATTLE GROUP (CVBG)**

*Forward...From the Sea*, the Navy's operational concept for the 21<sup>st</sup> century, outlines the Navy's unique contributions to national security stem from the advantages of operating on, under, above and from the sea. *Forward...From the Sea* provides the basis for a simple, yet powerful, operational concept of how the DoN will operate to carry out expeditionary operations. The primary purpose of forward-deployed naval forces is to project American power from the sea to influence events ashore in littoral regions of the world across the operational spectrum of peace, crisis and war (Boorda, Dalton, and Mundy 1992). The DoN's hallmark is forward-deployed forces with the highest possible readiness and capability to transition quickly from peace to crisis to conflict. At the center of this hallmark is the carrier battle group (CVBG).

The CVBG is a combat formation of ships and aircraft, which comprises a principal element of U.S. national power projection capability. CVBGs provide combatant commanders with adequately balanced capabilities to deal with a variety of present and future threats. The primary objective in defining a CVBG is to be responsive to the requirements of the supported commanders and carry out tasking from the National Command Authority (NCA). The main CVBG tasks are listed as follows: 1) surveillance / intelligence, 2) command and control, 3) air superiority, 4) maritime superiority, 5) power projection, 6) theater ballistic missile defense, 7) combat search and rescue, 8) amphibious force operations, and 9) sustainment (OPNAV Instruction 3501.316 1995).

The critical tasks listed above define the standard CVBG in terms of required capabilities and therefore provide the basis from which to derive the required force structure. It is important to note there is no single, authoritative definition of a CVBG. CVBGs are formed and disestablished on an as-needed basis. A "standard" CVBG provides the capabilities required to accomplish tasks in a notional threat environment against a notional threat, thereby the means to provide an initial crisis response mission from a rotationally deployed forward posture. A standard CVBG is defined in Table 2.3 (OPNAV Instruction 3501.316 1995).

Due to the complexities of command and control in modern naval warfare, the Navy uses the Composite Warfare Commander (CWC) concept for operations abroad. The Navy employs the CWC concept to counter advanced, weapon system acquisitions by third world countries. These acquisitions have reduced the reaction time for naval forces operating in sensitive areas.

Ship	Mission
One CV / CVN One Carrier Air Wing - 50 Strike/Fighter A/C - four E-2C AEW - four EA-6B SEAD/EW - eight S-3B - two ES-3A - six H-60	Ranges from forward presence to attacks on airborne, afloat and ashore targets.
Six surface combatants - CG - DDG/DD - FFG	CG: multi-mission surface combatant. Equipped with <i>Tomahawks</i> for long-range strike capability. DDG: multi-mission surface combatant. Used primarily for anti-air warfare (AAW). DD: Used primarily for anti-submarine warfare (ASW). FFG: Used primarily for anti-submarine warfare (ASW).
Two SSN	Used primarily to seek out and destroy hostile surface ships and submarines.
One multi-purpose AOE	Combined ammunition, oiler, and supply ship. Provides logistic support.

**Table 2. 3 Standard CVBG Composition (From OPNAV Instruction 3501.316 1995)**

Under this architecture, the CWC, also known as the battle group commander, is the central command authority for the battle group. Supporting the CWC are subordinate warfare commanders. The subordinate warfare commanders are responsible for collecting, evaluating and disseminating tactical information. At the CWC's discretion, they are delegated authority to respond to threats with assigned forces. Figure 2.3 defines the CVBG command and control (C2) organizational chart (Ready-for-Sea 1999, Battle Book 1999).

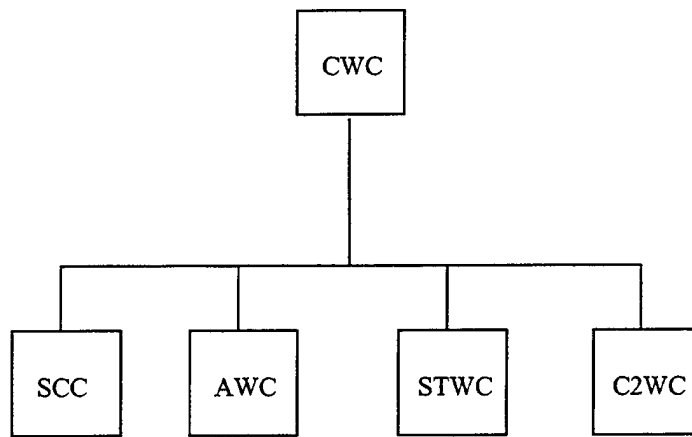

**Figure 2.3 CVBG Command and Control Organizational Chart (From Battle Book 1999)**

Each warfare commander has a role supporting the CVBG. The Sea Combat Commander (SCC) is primarily responsible for defending the CVBG against surface and sub-surface threats. The Air Warfare Commander (AWC) is responsible for defending against air threats. The Strike Warfare Commander (STWC) sets general strike philosophy, policy, and employs manned aircraft and tactical missiles. The Command and Control Warfare Commander (C2WC) advises the use and counter-use of the electromagnetic spectrum in theater (Ready-for-Sea 1999, Battle Book 1999).

**C. NETWORK-CENTRIC WARFARE (NCW)**

Currently, IT is undergoing a fundamental shift from platform-centric computing to network-centric computing. The significant IT investment in research and development and product application has produced key technologies, creating the emergence of network-centric computing. Now, information content can be created, distributed, and easily exploited across the heterogeneous global computing environment. This same concept can be applied to the U.S. Navy, Network-Centric Warfare (NCW).

Vice Admiral Arthur Cebrowski, the NCW champion, notes that NCW derives its power from the strong networking of a well-informed but geographically dispersed force. The NCW concept is supported by three grids: 1) the sensor grid, 2) the information grid, and 3) the engagement grid. The sensor grid consists of dedicated air, sea, ground, and space sensors and provides a high degree of awareness of the enemy and battlespace. The information grid provides the means to receive, process, transport, store, manage, and protect information. The engagement grid enables the warfighter to plan and execute operations in a manner that achieves an overwhelming effect at precise places and time. The grid combination results in a high-performance command and control (C2) grid that provides access to all appropriate information sources and closely couples operators and C2 processes (Cebrowski and Garstka 1998). Figure 2.4 shows the NCW logical model.

The two main NCW principles are speed of command and self-synchronization. Speed of command is the process by which a superior information position is turned into a competitive advantage. It is characterized by the decisive altering of initial conditions, the development of high rates of change and locking in success while locking out alternative enemy strategies. It is also characterized by making the right decision the first time. Self-synchronization is the ability of a well-informed force to organize and synchronize complex warfare activities from the bottom up. The organizing principles are unity of effort, clearly articulated commander's intent, and carefully crafted rules of engagement (Cebrowski and Garstka 1998).

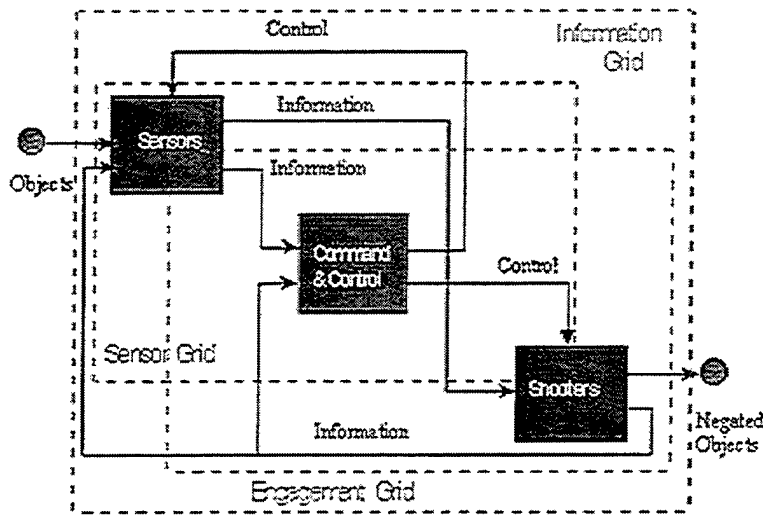

**Figure 2.4 NCW Logical Model (From Cebrowski and Garstka 1998)**

Both NCW principles, speed of command and self-synchronization, are key factors in the warfighting value chain. The warfighting value chain is a transformation of the sensor, information, and engagement grids into a sequential process, Figure 2.5. The warfighting value chain processes include 1) sensing, 2) processing, 3) assessing, 4) deciding, and 5) shooting. In NCW, the first three processes are highly automated systems, while the remaining processes require action by military personnel. Commanders involved in the decision process may have varying levels of experience and knowledge. A lack of experience or knowledge in this process precludes speed of command and self-synchronization. The Navy's training program provides adequate background knowledge, but experience and knowledge gained through naval operations are necessary to turn NCW into a competitive advantage.

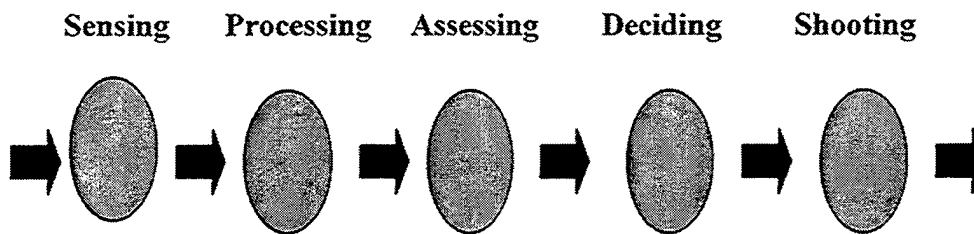

**Figure 2.5 NCW Warfighting Value Chain**

#### D. NAVAL INTELLIGENCE COMMUNITY

As per Naval Doctrine Publication 2 (NDP 2), naval intelligence, a system of personnel, procedures, equipment, and facilities, both afloat and ashore, provides insights into the uncertain world, both in peace and in war. Properly employed, intelligence can provide naval forces with an accurate estimate of the situation, forecast likely adversary courses of action, and allow commanders to apply selective but decisive combat power throughout the battlespace. The “fog of war” precludes military forces from having a complete picture of the battlespace, but naval intelligence can lessen the unknowns and reduce risk for friendly forces (Naval Doctrine Publication 2 1994).

Naval intelligence also provides indications and warnings, cuing for surveillance efforts, and discrimination between friendly, neutral, and potentially hostile forces. It gives the commander, his staff, and subordinate commands the information they need to plan and execute combat action and to evaluate the results. A commander must understand fully the capabilities and limitations of the overall process to employ intelligence resources effectively throughout his battlespace (Naval Doctrine Publication 2 1994).

NDP 2 lists and defines the primary purposes of naval intelligence: 1) supporting the commander, 2) identifying centers of gravity and critical vulnerabilities, 3) supporting planning and execution of operations, 4) protecting the force, and 5) supporting combat assessment. *Supporting the commander* allows the commander to use intelligence as a tool to evaluate the feasibility of, or determine risk factors associated with, objectives, plans and direct operations, and evaluate the effects of their actions. *Identifying centers of gravity and critical vulnerabilities* requires intelligence to strive to provide an accurate

picture of the battlespace from which naval forces can identify clear and attainable objectives. *Supporting planning and execution of operations* requires intelligence to provide staff support in both deliberate and crisis action planning. *Protecting the force* requires intelligence to provide early warning of impending hostile action and reduces risk by detecting adversary actions that can have an impact on friendly planning assumptions. *Supporting combat assessment* requires intelligence to develop combat assessments that can help the commander decide whether to redirect friendly forces or end operations (Naval Doctrine Publication 2 1994).

The battle group intelligence officer uses the intelligence cycle, a series of interrelated activities, to provide intelligence support to the battle group commander. The intelligence cycle is a process through which the battle group commander levies intelligence requirements, information is collected and converted into intelligence, and intelligence is disseminated to users. The intelligence cycle is depicted in Figure 2.6. This cycle normally consists of five steps: 1) planning and directing, 2) collection, 3) processing, 4) production, and 5) dissemination. This cycle greatly simplifies a dynamic and complex process, but it is useful to illustrate how the intelligence process works (Naval Doctrine Publication 2 1994).

NDP 2 explains each phase. During *planning and direction*, the commander must identify and prioritize his information requirements. *Collection* involves tasking organic, attached, and supporting collection resources to gather information. *Processing* is the conversion of collected information into a form suitable for producing usable intelligence. *Intelligence production* is the integration, analysis, evaluation, and interpretation of information from all available sources into tailored, usable intelligence.

The goal of the *dissemination* process is to provide the right amount of appropriately classified intelligence when, where, and how it is needed (Naval Doctrine Publication 2 1994).

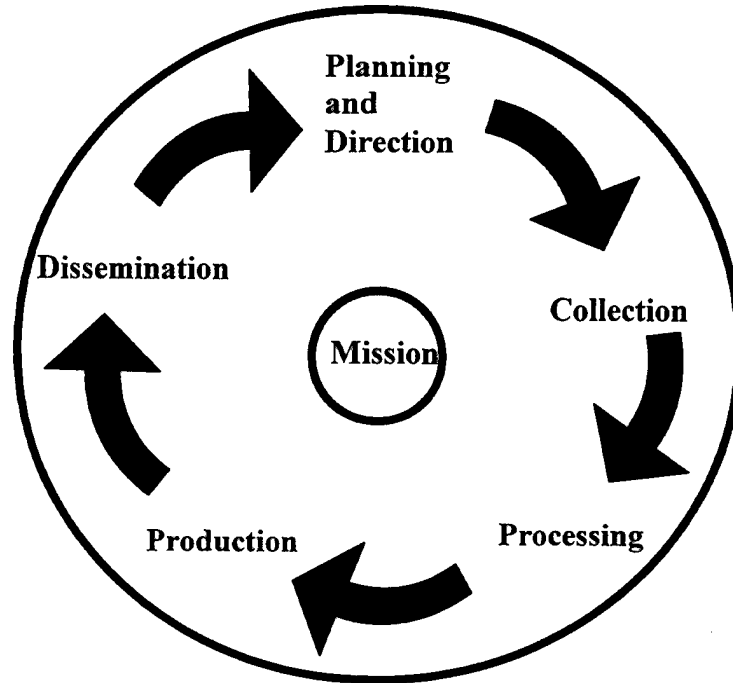

**Figure 2.6 Intelligence Cycle (From Naval Doctrine Publication 2 1994)**

#### **E. SUMMARY**

As the DoN develops the “Navy after Next,” knowledge acquired from naval operations and its management will be a significant factor in defeating potential adversaries in future regional military conflicts. In the 21<sup>st</sup> century, the DoN must employ KM to provide the Navy with a reliable, sustainable advantage. By managing and providing key knowledge via the intelligence cycle, NCW and future CVBG operations will meet the operational requirements in *Forward...From The Sea*.

### III. THE BATTLE GROUP THEATER TRANSITION PROCESS (BGTTTP) AT THE PACIFIC FLEET

Chapter III describes the BGTTTP in the U.S. Navy's Pacific Fleet (PACFLT). It explains the BGTTTP's origin and purpose and applies Nissen, Kamel, and Sengupta's knowledge management design approach to analyze the current BGTTTP.

#### A. THE BATTLE GROUP THEATER TRANSITION PROCESS (BGTTTP)

##### 1. BGTTTP Origin

Upon the conclusion of the Gulf War, the Department of the Navy (DoN) has maintained a carrier battle group (CVBG) in the Arabian Gulf to support the Commander, U.S. FIFTH Fleet (COMFIFTHFLT). COMFIFTHFLT is subordinate to the Commander, U.S. Naval Forces Central Command (COMUSNAVCENT), who is responsible for protecting vital U.S. national interests in the region. For operational matters, COMUSNAVCENT reports to the U.S. Central Command (USCENTCOM).

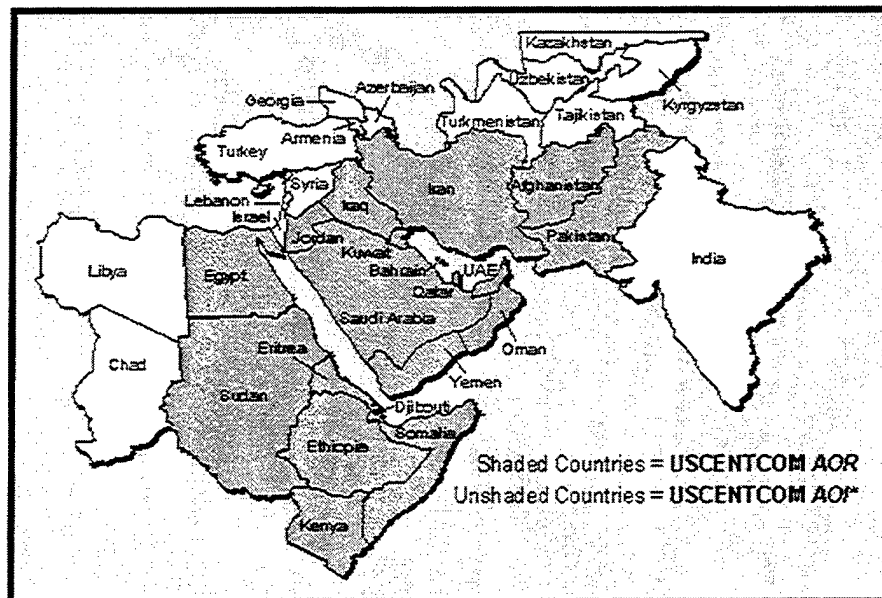

Figure 3.1 USCENTCOM Area of Responsibility (From COMFIFTHFLT 2000)

Figure 3.1 outlines USCENTCOM's area of responsibility (AOR) and area of interest (AOI).

CVBGs from both Atlantic and Pacific Fleets rotationally deploy to the region and are assigned as units of the U.S. FIFTH Fleet. Since the Gulf War, COMFIFTHFLT has employed the CVBG as a power projection instrument for three reasons: 1) to enforce the economic sanctions against Iraq, 2) to enforce the No-Fly Zone in southern Iraq, and 3) to maintain an U.S. naval presence. By doing so, COMFIFTHFLT supports the U.S. national security strategy and protects vital interests.

Typically, Gulf deployments are six months long, with three of the six months in the Arabian Gulf conducting naval operations to support the above three reasons. After conducting three months of naval operations in the Gulf, a second CVBG relieves the first CVBG. In the past, the two CVBGs conducted a face-to-face turnover outside the Arabian Gulf. The departing CVBG transferred pertinent information for conducting operations in the Gulf and supporting COMFIFTHFLT to the arriving CVBG, allowing for a smooth transition between CVBGs. The transfer of data and information between CVBGs is the Battle Group Theater Transition Process (BGTTP).

## **2. BGTTP Purpose**

The current theater transition process conducted between CVBGs provides the arriving battle group with explicit, theater, background knowledge, but the experience and tacit knowledge acquired through theater operations by the departing battle group may not be transferred during the process. The BGTTP's primary objective is to capture and transfer knowledge between CVBGs enabling the arriving battle group (BG) to better support COMFIFTHFLT, which is primarily responsible for naval operations in the

Arabian Gulf. The BGTTP also reduces the arriving BG's theater familiarization period by increasing its situational awareness. Increasing situational awareness allows the BG to effectively respond to any indications & warnings (I & W) and engage a potential threat accordingly if an immediate need arises.

## **B. KNOWLEDGE MANAGEMENT DESIGN PROCESS**

### **1. Introduction**

Due to high operational tempo (OPTEMPO) and the BG's schedule, face-to-face turnovers are becoming a thing of the past. Although information technology (IT) mitigates some of the losses caused by skipping face-to-face turnovers, key knowledge is not being transferred in the process. In this section, the author conducts research to identify a target process for analysis and apply Nissen, Kamel, and Sengupta's knowledge management (KM) design process to improve BGTTP performance.

### **2. Research**

Because the BGTTP consists of several turnovers conducted by counterparts in each CVBG, research was conducted to identify and select a process with KM implications for analysis. Interviews were conducted with battle group staff officers of two CVBGs, Commander Cruiser Destroyer Group ONE (COMCRUDESGRU ONE) and Commander Carrier Group SEVEN (COMCARGRU SEVEN), and a CVBG training command, Commander Carrier Group ONE (COMCARGRU ONE). Research objectives were the following:

1. Identify how turnover is currently being conducted.
2. Identify key BG operations.
3. Identify key decision processes.
4. Identify key knowledge acquired on station.
5. Identify key knowledge requested on day one of operations in theater.
6. Contrast capabilities between day one and three months of operations in theater.

During the interviews and upon conclusion, two themes were common, Secret Internet Protocol Routing Network (SIPRNET) connectivity and trend analysis, Table 3.1. SIPRNET, the military's classified version of the Internet, allows access to command websites and email. Trend analysis is the ability to analyze data and evaluate a country's operations or activities as normal or abnormal.

<b>Common Research Themes</b>
<p><u>SIPRNET connectivity</u></p> <ul style="list-style-type: none"> <li>• Significant factor in facilitating turnover               <ul style="list-style-type: none"> <li>➤ Replacing message traffic which was one way</li> <li>➤ Data transformed into information by value added</li> <li>➤ Faster communication medium</li> <li>➤ Inform fleet counterparts, not just relief, of lessons learned</li> <li>➤ Peer-to-Peer correspondence</li> <li>➤ Face-to-Face turnover is valuable but no longer required</li> </ul> </li> </ul>
<p><u>Trend Analysis</u></p> <ul style="list-style-type: none"> <li>• Patterns</li> <li>• Norms</li> <li>• Predictable actions</li> </ul>

**Table 3.1 Common Research Themes**

### **3. Process Analysis**

The first stage of the KM design process, process analysis, requires understanding the objectives and strategies of an enterprise and generally entails process modeling and analysis that results in one or more redesigns for the process in question. The process, along with its various redesign opportunities and required knowledge, must be understood first before designing systems. Although many methodologies have been

developed for process redesign, this thesis uses Nissen’s measurement-driven redesign knowledge system, KOPeR, which automatically diagnoses process pathologies and recommends redesign transformations (Nissen, Kamel, & Sengupta 2000).

Nissen describes reengineering, also known as redesign, in terms of process-redesign activities organized as an evolutionary spiral, Figure 3.2, to denote increasing process knowledge and understanding as the reengineering activity progresses (Nissen 1998). Step one is to identify a target process for redesign. Next, a model is constructed to represent the baseline (i.e., “as is”) configuration of this process, and configuration measurements then drive the diagnosis of process pathologies. The diagnostic results are used in turn to match the appropriate redesign transformations available to “treat” pathologies detected. This sequence of analytical activities leads systematically to the generation of one or more redesign alternatives, which most experts argue should be tested through some mechanism (esp. simulation) prior to selection of a preferred alternative for implementation (Nissen, Kamel, & Sengupta 2000).

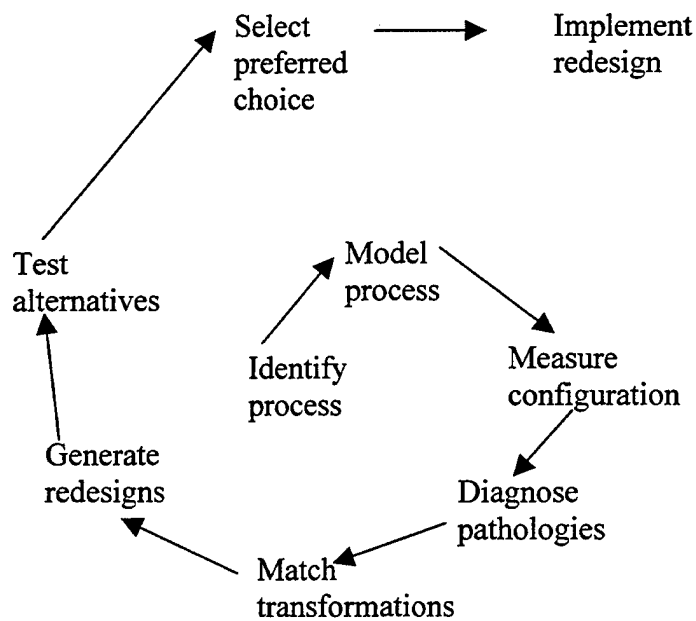

**Figure 3.2 General Redesign Process (From Nissen, Kamel, & Sengupta 2000)**

*a. Identify the Target Process*

While deployed in the Arabian Gulf, the BG intelligence staff supports various missions and has multiple duties. However, this thesis focuses on intelligence support provided to the BG and Destroyer Squadron (DESRON) commanders for Operation Southern Watch (OSW) and maritime interdiction operations (MIO). Recalling the composite warfare commander (CWC) concept, the BG commander, as the CWC, is primarily responsible for all CVBG operations but can delegate authority to subordinate warfare commanders. Usually, the BG commander maintains OSW authority and designates the DESRON commander as the MIO authority. Through OSW, the BG commander enforces the No-Fly Zone in southern Iraq, and through MIO, the DESRON commander enforces the economic sanctions against Iraq.

Based on research, the results revealed the identification of patterns and norms as the key knowledge desired prior to entering the Arabian Gulf and trend analysis as the key knowledge acquired on station. Trend analysis, the identification and continued analysis of patterns and norms, is essential for planning and conducting operations in the Arabian Gulf. It is a form of intelligence preparation of the battlespace (IPB) and used primarily for I & W. As per Naval Doctrine Publication 2 (NDP 2), IPB is the systematic and continuous analysis of the current or potential adversary, terrain, and weather in the battlespace. Trend analysis reduces risk by preventing surprise and detecting adversary actions that may threaten friendly forces (Naval Doctrine Publication 2 1994). By conducting trend analysis, BG situational awareness increases, reducing the theater familiarization period. Because of its role in improving the BGTTP, the author selects trend analysis as the target process for redesign.

Trend analysis is a responsibility of the BG intelligence staff and follows the intelligence cycle process. The cycle simplifies a dynamic and complex process that is iterative and does not always flow sequentially, but it is useful to illustrate how trend analysis works. Nissen, Kamel, and Sengupta's KM design process methodology can be applied to the intelligence cycle, Figure 3.3, to diagnose pathologies in the trend analysis process.

The analytical skills required for trend analysis are exercised in the production phase of the intelligence cycle. In this phase, expertise and knowledge (e.g., how the analyst analyzes and interprets data) are acquired and developed. The primary objective is for the arriving BG (BG 2) to perform, on day one of operations in theater, as if it were on the departing BG's (BG 1) 90th day of operations in theater. Ideally, if both BGs receive the same data at different times, the trend analysis results should be the same. By capturing and transferring the departing BG's tacit knowledge and experience used to conduct trend analysis to the arriving BG, the arriving BG increases its situational awareness and can effectively respond to an emerging crisis.

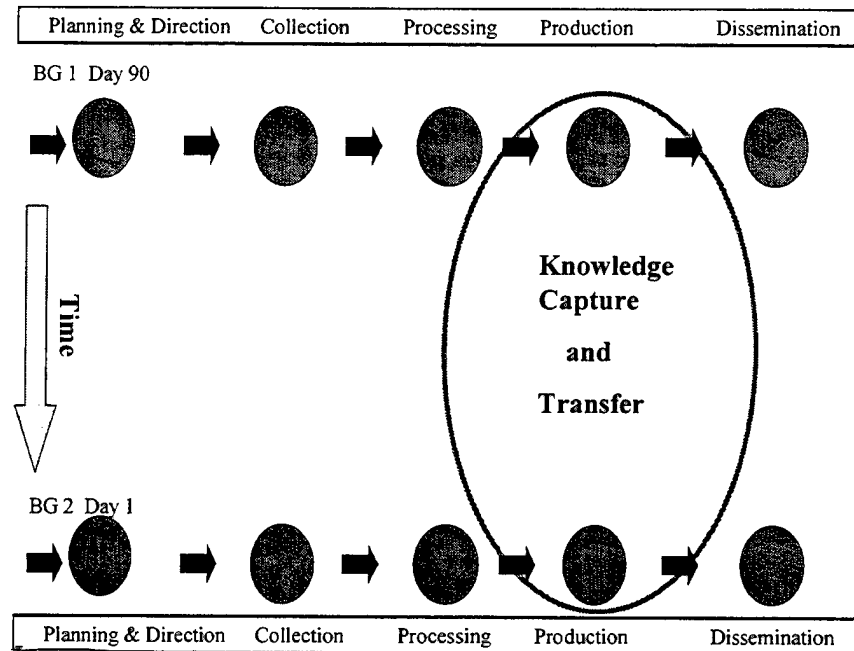

**Figure 3.3 Knowledge Capture and Transfer between Battle Groups**

***b. Model the Process***

Although no formal process exists, the intelligence cycle is used to illustrate its analytical flow. Simplifying the process, the thesis focuses on the collection through dissemination phases. The collection of data initiates the process resulting in an intelligence product that is disseminated to the BG and DESRON commanders. The commanders use this product to make better-informed decisions regarding OSW and MIO. The following information is included for each step in the process: 1) task name, 2) agent performing the task, 3) the agent's organization, 4) input, 5) output, 6) IT-support (IT-S), 7) IT-communication (IT-C), and 8) IT-automation (IT-A). IT-S is IT used to convert or transform the input into output. IT-C is IT used to communicate or transfer the output. IT-A is IT used to automate manual processes. Figure 3.4 is the intelligence cycle model.

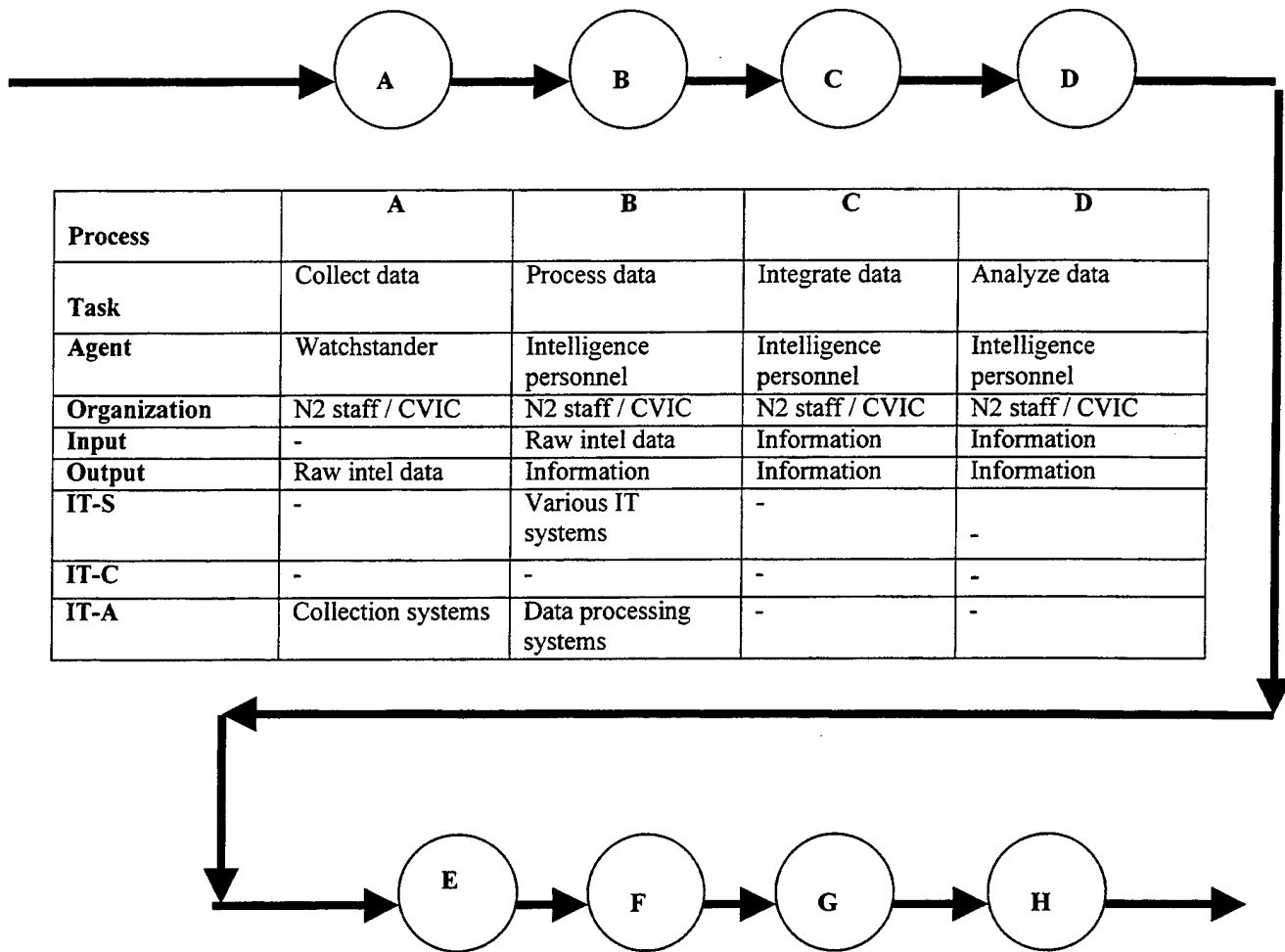

	A	B	C	D
<b>Process</b>				
<b>Task</b>	Collect data	Process data	Integrate data	Analyze data
<b>Agent</b>	Watchstander	Intelligence personnel	Intelligence personnel	Intelligence personnel
<b>Organization</b>	N2 staff / CVIC	N2 staff / CVIC	N2 staff / CVIC	N2 staff / CVIC
<b>Input</b>	-	Raw intel data	Information	Information
<b>Output</b>	Raw intel data	Information	Information	Information
<b>IT-S</b>	-	Various IT systems	-	-
<b>IT-C</b>	-	-	-	-
<b>IT-A</b>	Collection systems	Data processing systems	-	-

	E	F	G	H
<b>Process</b>				
<b>Task</b>	Evaluate data	Interpret data	Produce intel product	Distribute intel pro
<b>Agent</b>	Intelligence personnel	Intelligence personnel	N2 / Intelligence Analysis & Reporting Cell	N2 / Intelligence Analysis & Reporting Cell
<b>Organization</b>	N2 Staff / CVIC	N2 staff / CVIC	N2 staff / CVIC	N2 staff / CVIC
<b>Input</b>	Information	Information	Intelligence	Intel product
<b>Output</b>	Information	Intelligence	Intelligence product	Intel product
<b>IT-S</b>	-	-	Various IT tools (MS Office tools)	-
<b>IT-C</b>	-	-	-	SIPRNET, LAN, brief, report
<b>IT-A</b>	-	-	-	-

**Figure 3.4 Intelligence Cycle Model**

In phase A, collection systems collect and provide raw intelligence data to users. In this case, the user is an intelligence watchstander standing a tactical, I & W watch. This watchstander is either part of the BG intelligence staff, N2, or the carrier intelligence center (CVIC). In phase B, after the data has been collected, the N2's staff or CVIC's Intelligence Analysis & Reporting Cell (IA&RC) uses various IT and data processing systems to convert the raw data into a usable form of information. During phases C through F, intelligence personnel conduct trend analysis by integrating, analyzing, evaluating, and interpreting the processed information. In phase G, the N2 staff or the IA&RC uses various IT tools to incorporate the intelligence data and produce an intelligence product that is distributed to the BG and DESRON commanders. Although not depicted here, there is an existing feedback loop to the planning and direction phase. In this phase, either commander or the intelligence staff can request additional collection of areas of interest to make better decisions or improve trend analysis.

*c. Configuration Measurements and Diagnosis*

Before diagnosing the current "as is" trend analysis process, the author provides KOPeR with input process measurements taken from Figure 3.4. KOPeR bases its inference on a measurement-driven redesign method. Its graph-based measurement scheme uses attributed digraph (A-digraph) information from a represented process to drive its diagnostic inference. KOPeR generates diagnostic process measurements and uses these measurements to diagnose pathologies existing in the current process. KOPeR then uses its knowledge base to identify redesign transformations that are fitting to treat the existing pathologies and improve process performance.

KOPeR requires the following input process measurements:

- process size: number of process activities
- process length: length of longest path
- handoffs: number of inter-agent transfers of work
- feedback loops: number of quality / feedback loops
- IT-S: number of process tasks supported by IT
- IT-C: number of process communications supported by IT
- IT-A: number of process tasks automated by IT

Table 3.2 shows the input measurements submitted for the current trend analysis process.

<b>Input Measure</b>	<b>Value</b>
Process size	8
Process length	8
Handoffs	2
Feedback loops	1
IT-S	2
IT-C	1
IT-A	2

**Table 3.2 Process Input Measurements**

After entering the process measurements into KOPeR, the following diagnosis is presented, Table 3.3. The diagnosis reveals that the current trend analysis process is a sequential process with sufficient handoffs, feedback, and automation but lacks adequate IT support and communication within phases C through F, which is where trend analysis occurs. Regarding IT support, this indicates that even though there are an abundance of IT tools available to support daily routine tasks, no IT tools are currently being used to support trend analysis in CVBGs. The IT-C fraction is low and poses no significant problem locally because trend analysis is likely conducted by the same staff or watch team. However, it does pose a problem during the BGTP when the departing

staff cannot transfer and share its knowledge used to conduct trend analysis. In Chapter IV, the author continues the redesign process and generates redesign alternatives to treat the IT-S and IT-C pathologies; therefore, improving the trend analysis process.

<b>Configuration Measure</b>	<b>Value</b>	<b>Diagnosis</b>
Parallelism	1.0	Sequential process
Handoffs fraction	0.25	OK
Feedback fraction	0.125	OK
IT support fraction	0.25	Inadequate IT support
IT communication fraction	0.125	Inadequate IT communication
IT automation fraction	0.25	OK

**Table 3.3 KOPeR Diagnosis**

#### **4. Knowledge Analysis**

Prior to conducting knowledge analysis, the organization's mission and goal must be fully understood. Subsequently, knowledge analysis involves identifying key knowledge within an organization and results in a thorough understanding of critical success factors (CSF). Knowledge analysis also identifies the key explicit and tacit knowledge employed to make decisions and take action (Nissen, Kamel, & Sengupta 2000).

CVBGs are capable of conducting a variety of missions depending on the theater of operations and its geo-political environment. For CVBGs operating in the Arabian Gulf, the key BG operations are OSW and MIO. Each operation has a primary objective and CSFs, Table 3.4. The success of each operation depends on the achievement of each CSF, thus accomplishing the primary objective.

**Operation Southern Watch (OSW)***Primary Objective*

- Enforce the No-Fly Zone in southern Iraq

*Critical Success Factors*

- High situational awareness (current, accurate intelligence)
- Prevent violation
- Complete air tasking order (ATO)
- Good, reliable communication within theater
- Adequate I & W of potential violation

**Maritime Interdiction Operations (MIO)***Primary Objective*

- Enforce economic sanctions against Iraq

*Critical Success Factors*

- High situational awareness (current, accurate intelligence)
- Good, reliable communication within theater
- Well trained and properly equipped boarding crew
- Sufficient assets for ship placement and boardings
- Prevent violation

**Table 3.4 Mission Objectives and Critical Success Factors**

For both BG operations, intelligence is a significant factor and provides key knowledge essential for success. Both operations require a high degree of situational awareness derived from trend analysis. The N2, the BG Intelligence Officer, provides this intelligence support to the BG commander and his staff for day-to-day decision making regarding OSW and MIO. To develop and acquire the analytical skill applied in trend analysis requires training, experience, and knowledge.

Explicit knowledge of patterns and norms is accessible prior to deployment through various intelligence products, such as manuals, books, lessons learned, and training exercises. The BG intelligence staff uses the Inter-deployment Training Cycle (IDTC), an 18-month (mos) pre-deployment training cycle, as a training opportunity. The IDTC's primary purpose is to increase the unit's readiness and warfighting skills. During the IDTC, the BG intelligence staff conducts exercises simulating operations in

the threat environment. These training exercises serve as an introduction to provide the intelligence staff with explicit, theater knowledge of the threat and operating environment. Prior to deployment, the N2 provides the BG and DESRON commanders with known patterns and norms, which are used for *deliberate planning*. As per NDP 2, in *deliberate planning*, the commander's emphasis is on developing a carefully crafted plan for military operations

Tacit knowledge used in trend analysis is not readily accessible and gained only through on-the-job training (OJT) and experience. Formal training during the IDTC provides explicit, background knowledge but not tacit knowledge. Tacit knowledge is the know-how to identify operations or activities as normal or abnormal, how the analyst evaluates and interprets the data. The identification of an activity or operation as normal or abnormal is used as I & W, which supports *crisis action planning*. In *crisis action planning*, the commander's emphasis is on developing a course of action to respond to an emergent crisis. The intelligence staff acquires this tacit knowledge only by operating in the Gulf for 90 days.

## **5. Context Analysis**

In context analysis, the organization and the knowledge underlying the task are the focus. The knowledge and CSFs required for each operation are supported by intelligence. Unlike the explicit knowledge presented in intelligence products, there is no formal system used to codify tacit knowledge used for trend analysis. OJT and experience develop this key tacit knowledge. In the past when turnovers were conducted face-to-face, knowledge exchange was conducted explicitly and tacitly by transferring intelligence products and discussion. Table 3.5 outlines current methods used at

attempting to codify and transfer tacit knowledge. However, these methods only provide explicit knowledge.

<b>BGTTP Instruments</b>	
<b>Lessons Learned</b>	<ul style="list-style-type: none"> <li>- Review on-station CVBG's mid-cruise and end-of-cruise lessons learned via website, email, or message traffic</li> <li>- Review 6 mos or less prior to deployment</li> </ul>
<b>Secret Internet Protocol Routing Network (SIPRNET)</b>	<ul style="list-style-type: none"> <li>- Access command websites</li> <li>- Email relieving fleet counterpart and others throughout course of deployment</li> </ul>
<b>Inter-Deployment Training Cycle (IDTC)</b>	<ul style="list-style-type: none"> <li>- Initiate 18 mos prior to deployment</li> <li>- Increase unit's readiness and warfighting skills prior to deployment</li> </ul>
<b>Message Traffic</b>	<ul style="list-style-type: none"> <li>- Add relieving CVBG to message traffic list to receive routine message traffic</li> <li>- Receive departing CVBG's message traffic 6 mos prior to deployment</li> </ul>
<b>Phone</b>	<ul style="list-style-type: none"> <li>- Use secure phone (STU III) when enroute to Gulf</li> </ul>

**Table 3.5 Current BGTTP Methods**

The failure to capture and codify tacit knowledge is further exacerbated by the periodic rotation of personnel ashore and afloat. Often prior to deployment, personnel transfer to their next assignment taking their experience and knowledge with them. Without this experience and knowledge, each BG intelligence staff is likely to "re-invent" the wheel regarding trend analysis. Remaining and new personnel must rely on the methods in Table 3.5 for knowledge capture and transfer, but again, this is explicit knowledge only.

## **6. Systems Analysis**

In system analysis, the organization's current procedures and information systems used to perform organizational tasks are analyzed. For trend analysis, there is no formal IT system used to capture and share the departing CVBG's tacit knowledge and

experience. As indicated in the KOPeR diagnosis, the current process lacks adequate IT in the support and communication areas. This is evident in phases C through F of the intelligence cycle model, Figure 3.4.

In order to correct these pathologies, a formal system must be identified and implemented achieving the following requirements: 1) captures and transfers tacit knowledge; 2) facilitates knowledge exchange; 3) and serves as a knowledge repository. An alternative solution is to employ a knowledge-based system that will capture, store, and transfer the tacit knowledge used in trend analysis.

### **C. SUMMARY**

While on station in the Arabian Gulf, the key knowledge identified for capture and transfer is the tacit knowledge acquired during the trend analysis process; therefore, trend analysis is selected as the target process for redesign. However, there is no formal existing system designed to capture and share this tacit knowledge, and current BGTTP methods provide explicit knowledge only. In order to effectively capture and transfer this key knowledge between CVBGs to increase situational awareness and decrease theater familiarization periods, a knowledge-based system enabling the capture, storage, and transfer of knowledge must be employed to treat the current IT pathologies identified by KOPeR.

#### **IV. INNOVATING KNOWLEDGE MANAGEMENT AT THE PACIFIC FLEET**

Chapter IV innovates knowledge management (KM) to the Battle Group Theater Transition Process (BGTTP) by continuing the redesign process. This includes identifying process transformations, generating redesign alternatives, and selecting a redesign alternative to improve the BGTTP. Chapter IV also outlines a migration strategy to implement the redesign alternative into the BGTTP and discusses how to evaluate its integration.

##### **A. PROCESS REDESIGN**

As enterprises continue to adopt and employ KM, information technology (IT) plays a significant role in creating and supporting the KM infrastructure. Knowledge and IT are mutually dependent in organizations aspiring to be knowledge-creating and knowledge-learning enterprises. According to Davenport and Prusak, KM is much more than technology, but “techknowledge” (Davenport and Prusak 1998).

For some time, finding the person with the knowledge one needs, and then successfully transferring it from one person to another, was and remains a difficult process. However, today, technology’s primary role in KM is to effectively capture and store corporate knowledge, then extend the reach and accessibility of this knowledge throughout an organization. Enterprises use IT to codify tacit knowledge and provide the means for storage and distribution.

In this first section, the author continues the redesign process by discussing process transformation and redesign alternatives that seem to offer the greatest promise in terms of process improvement. The author also evaluates the redesign alternatives using

KOPeR and contrasts the results with that of the current “as is” trend analysis process. This section concludes with a selected redesign alternative and discusses a migration strategy to implement the redesign alternative.

### 1. Match Transformations

This section begins by defining and identifying redesign transformations.

Redesign transformations are conversion mechanisms used to correct process pathologies identified by KOPeR. Table 4.1 presents some redesign transformations. The author discusses each transformation briefly. Of note, these transformations are not mutually exclusive.

Pathology	Transformation
Sequential process flows	De-linearize
Checking and complexity	Asynchronous reviews or empowerment
Process friction	Case manager or case team
Manual process	Integrated databases or workflow
Paper-based process	E-mail or workflow
Labor-intensive process	Expert systems or intelligent agents

**Table 4.1 Redesign Transformations (From Nissen, Kamel, & Sengupta 2000)**

De-linearization involves performing two or more processes in parallel and is used to treat sequential processes. To counter checking and complexity, asynchronous reviews or empowerment can be applied. Asynchronous reviews involve conducting reviews in parallel while empowerment requires analysts to review their own work. Case managers or teams are used to correct process friction, caused by multiple handoffs, by dissolving and replacing a specialized division of labor and functional organization with a

single person or small team that performs all the process activities. The last three transformations involve the use of IT (e.g., shared database, e-mail, Intranet). IT is used to replace mundane tasks, increase efficiency, and improve process performance.

Recalling from Chapter III the KOPeR diagnosis of the intelligence cycle model, repeated for reference, Figure 4.1, the “as is” trend analysis process required improvement in IT support and communication. In phases C through F, IT is not used to capture, store, and exchange tacit knowledge applied in trend analysis. Because of this inefficiency, BG intelligence staffs repeatedly construct a knowledge base that is common to other BG intelligence staffs but not shared. Therefore, the author focuses on IT to correct the current trend analysis process pathologies.

Recently, IT development has resulted in several technologies that further support the KM movement. Some KM tools require the user to be an expert on the topic. Others assume the user is only a participant in the knowledge process. Although there are several IT systems supporting KM, this thesis focuses on, in particular, knowledge repositories and knowledge-based systems (KBS). Knowledge repositories (e.g., Web and groupware) require some degree of user knowledge and time to find specific desired knowledge because the user must search for knowledge. KBS (e.g., expert systems and intelligent agents) require minimum user knowledge but time to find the desired knowledge. Examples of these KM tools are shown on Figure 4.2.

Knowledge repositories and KBS counter potential knowledge loss. Both capture and retain key knowledge before it is lost or reduced by attrition and high turnover rates, and each effectively shares common knowledge stored in a knowledge base. Moreover,

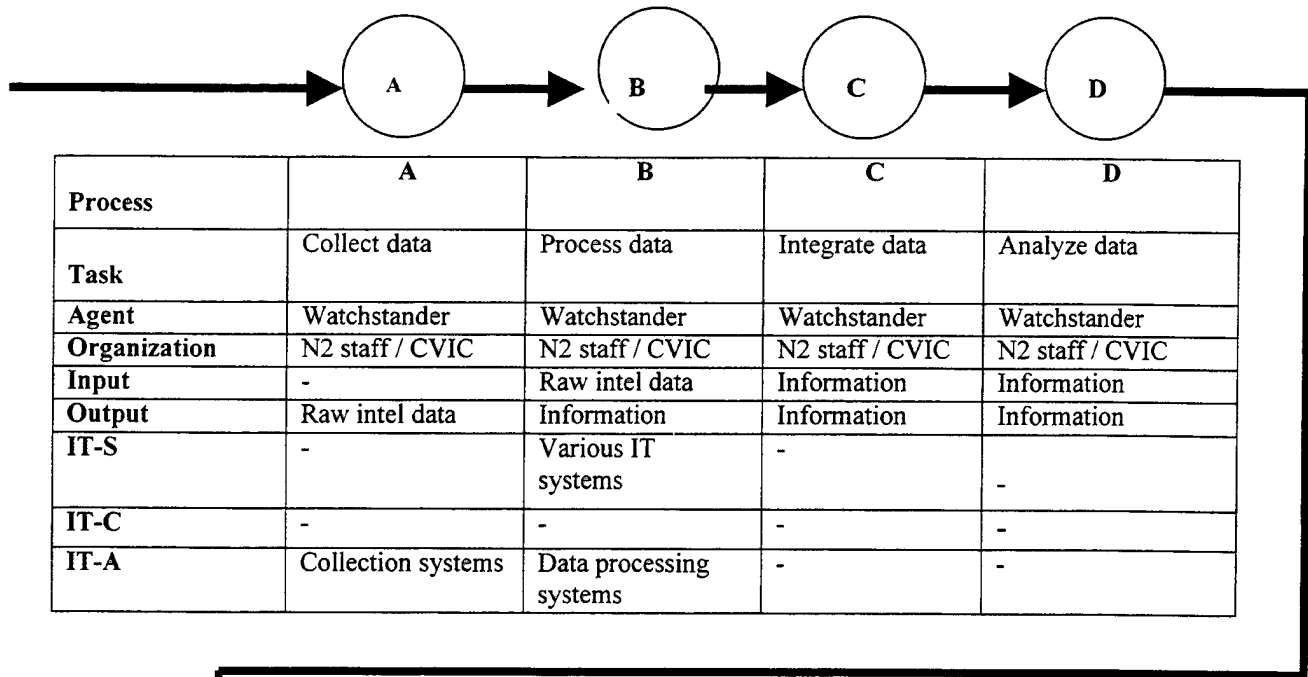

	A	B	C	D
<b>Process</b>				
<b>Task</b>	Collect data	Process data	Integrate data	Analyze data
<b>Agent</b>	Watchstander	Watchstander	Watchstander	Watchstander
<b>Organization</b>	N2 staff / CVIC	N2 staff / CVIC	N2 staff / CVIC	N2 staff / CVIC
<b>Input</b>	-	Raw intel data	Information	Information
<b>Output</b>	Raw intel data	Information	Information	Information
<b>IT-S</b>	-	Various IT systems	-	-
<b>IT-C</b>	-	-	-	-
<b>IT-A</b>	Collection systems	Data processing systems	-	-

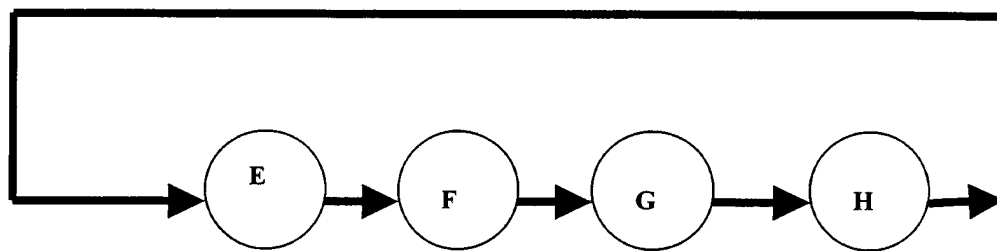

	E	F	G	H
<b>Process</b>				
<b>Task</b>	Evaluate data	Interpret data	Produce intel product	Distribute intel pro
<b>Agent</b>	Watchstander	Watchstander	N2 / Intelligence Analysis & Reporting Cell	N2 / Intelligence Analysis & Reporting Cell
<b>Organization</b>	N2 Staff / CVIC	N2 staff / CVIC	N2 staff / CVIC	N2 staff / CVIC
<b>Input</b>	Information	Information	Intelligence	Intel product
<b>Output</b>	Information	Intelligence	Intelligence product	Intel product
<b>IT-S</b>	-	-	Various IT tools (MS Office tools)	-
<b>IT-C</b>	-	-	-	SIPRNET, LAN, brief, report
<b>IT-A</b>	-	-	-	-

**Figure 4.1 Intelligence Cycle Model**

both offer good potential to play a key role in treating the pathologies from above identified by KOPeR.

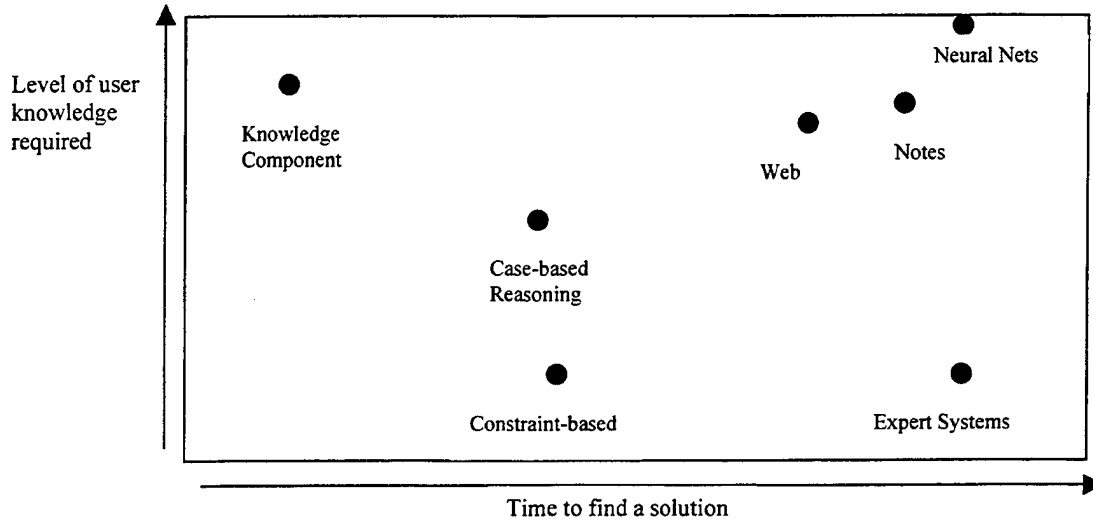

**Figure 4.2 Key Dimensions of Knowledge Management Tools (From Davenport and Prusak 1998)**

**2. Generate Redesign Alternatives**

Prior to each deployment, the intelligence staff conducts formal training and exercises to build a knowledge base of the Gulf environment. While on station in the Gulf, the intelligence staff gains experience and acquires tacit knowledge, which adds to the knowledge base. At the end of deployment, the departing intelligence staff provides the arriving intelligence staff with lessons learned, summarizing its experience in theater. However, this knowledge is explicit. This method, along with other mentioned BGTP methods, does not capture and share the tacit knowledge stored in the knowledge base. Based on the interview results, this knowledge base is common to all battle groups (BG), but it is not easily transferred from one BG to the next. This process redesign employs two classes of IT: knowledge repositories and KBS.

*a. Alternative One: Knowledge Repositories*

Through knowledge repositories, corporate knowledge can be saved and preserved for future use. Knowledge repositories capture and maintain structured, explicit knowledge, usually in document form, for use throughout an organization. There are three basic types of repositories: 1) *external knowledge* (e.g., competitive intelligence), 2) *structured internal knowledge* (e.g., research reports, techniques and methods), and 3) *informal internal knowledge* (e.g., discussion databases full of know-how, sometimes referred to as “lessons learned”) (Thomas H. Davenport, David W. De Long, Michael C. Beers 1998).

The knowledge applied in trend analysis is tacit, plain and simple know-how. To transfer tacit knowledge from individuals into a repository, some sort of community-based electronic discussion is often employed (e.g., groupware). This type of knowledge repository, a combination of structured internal and informal internal knowledge, is an attempt to accelerate and broaden the traditional knowledge sharing that happens with the socialization of newcomers, the generation of myths and stories within communities of practice, and the general transmission of cultural rituals and organizational routines (Thomas H. Davenport, David W. De Long, Michael C. Beers 1998). For the BGTTP, the author focuses specifically on the application of groupware.

Today, groupware is becoming more prevalent in enterprises as an effort to operate more efficiently and innovate new ideas by tapping into corporate knowledge. Groupware is software that permits two or more people to communicate and collaborate and is the cornerstone for most electronic knowledge sharing (Liebowitz 1999). Groupware provides rich content and real interactivity via presentations,

demonstrations, e-whiteboards, chat, audio, and video. These tools facilitate the capture and exchange of tacit knowledge. Through collaboration and discussion, knowledge is evoked, then captured and stored in a knowledge repository.

This technology is ideal to improve the transfer of tacit knowledge used to conduct trend analysis because it provides a mechanism capable of replacing the face-to-face turnover, facilitates knowledge exchange, and stores the key knowledge in a repository. Groupware re-establishes the medium lost during the face-to-face turnover absence. The current BGTP methods suffice but transfer explicit knowledge only. To transfer tacit knowledge, discussion and interaction are key. Groupware provides the means for discussion, collaboration, as well as the storage. It maximizes human interaction while minimizing technology interference.

By using groupware, tacit knowledge is transferred to the arriving intelligence staff. With the acquired tacit knowledge, the intelligence staff can more efficiently conduct trend analysis and provide the BG and Destroyer Squadron (DESRON) commanders with better intelligence support. The BG and DESRON commanders can use this support to make better decisions regarding Operation Southern Watch (OSW) and maritime interdiction operations (MIO).

Today, Lotus Notes is one of the leading collaboration tools and the leading management tool for knowledge repositories, both structured and informal internal. Lotus Notes is a groupware tool permitting the capture and exchange of both explicit and tacit knowledge. Its strength lies in database management, discussion-group creation and management, the replication of databases for remote disconnected use in the field, and its ability to integrate web and desktop applications.

Groupware technology is emerging in the Pacific Fleet and is currently being employed within the USS JOHN C. STENNIS CVBG. Although the Department of the Navy (DoN) has implemented IT-21 as its IT strategy for the 21<sup>st</sup> century, afloat units, particularly CVBGs, continue to experience repeating problems on each deployment. The current CVBG problems are two-fold: 1) the inability to connect a large group of worldwide users to a massive amount of widely distributed information via narrow and intermittently connected channels with sufficient speed and accuracy to facilitate tactical and strategic decisions, and 2) the continuous generation of knowledge common to all CVBGs.

Currently, the STENNIS CVBG is employing Lotus Domino to provide the capability for rapid, flexible, robust collaboration, planning and execution of all CVBG operations. Domino is being used to establish a classified BG collaboration environment as a repository of the current tactical picture, implement a single BG directory, implement Sametime Chat and Net Awareness, and replicate the knowledge repository to other CVBG units. Domino also supports the ability to rapidly scale to a dynamic, multinational force, complements existing application investment, and is compatible with the communications infrastructure (Lenci 2000).

The implementation of Lotus technology within the STENNIS BG is the first step in creating a KM infrastructure for afloat units. Given the success within the STENNIS CVBG, plans are underway to innovate an Atlantic-based CVBG with Lotus Domino. Over time, if Lotus Domino or similar groupware technology is adopted throughout the Navy, units, afloat and ashore, can share explicit and tacit knowledge.

Figure 4.3 shows the redesign process incorporating groupware technology. Groupware is used as IT-communication (IT-C) because it provides a medium in which BGs can conduct discussions, exchanging information and knowledge. By using groupware, the departing BG is able to share its knowledge explaining how it integrated, analyzed, evaluated, and interpreted data used in trend analysis. Afterwards, this knowledge is stored in the repository, which maintains structured and informal internal knowledge.

***b. Alternative Two: Knowledge-based Systems***

While capturing knowledge is the objective of the knowledge repository, KBS share and distribute knowledge. “Even though computers cannot have experiences or learn as the human mind can, it can acquire knowledge given to it by experts” (Frenzel, Jr. 1987, pg. 1). Decision makers are primarily knowledge workers. Everyday, decision makers depend on knowledge to make better-informed decisions. This knowledge is derived from a knowledge base, an understanding of some subject area obtained through education or experience (Frenzel, Jr. 1987, Turban and Aronson 1998). KBS share and distribute knowledge indirectly by using a knowledge base and inferencing capability, Figure 4.4. By searching the knowledge base for relevant facts and relationships, the computer can reach one or more alternative solutions to the problem. Because of its knowledge base and an inferencing capability, the computer becomes a more useful tool, which supplements and enhances human capabilities for

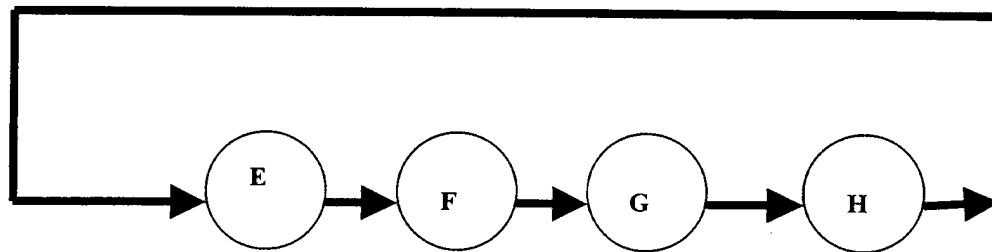
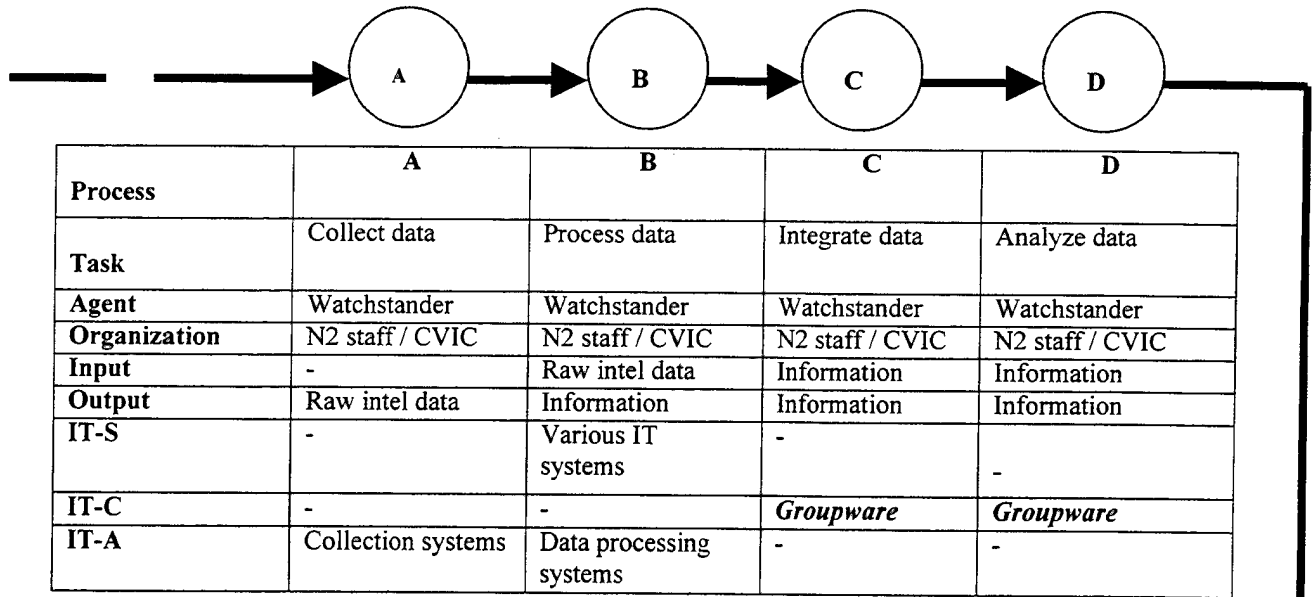

	E	F	G	H
<b>Process</b>				
<b>Task</b>	Evaluate data	Interpret data	Produce intel product	Distribute intel pro
<b>Agent</b>	Watchstander	Watchstander	N2 / Intelligence Analysis & Reporting Cell	N2 / Intelligence Analysis & Reporting Cell
<b>Organization</b>	N2 Staff / CVIC	N2 staff / CVIC	N2 staff / CVIC	N2 staff / CVIC
<b>Input</b>	Information	Information	Intelligence	Intel product
<b>Output</b>	Information	Intelligence	Intelligence product	Intel product
<b>IT-S</b>	-	-	Various IT tools (MS Office tools)	-
<b>IT-C</b>	<i>Groupware</i>	<i>Groupware</i>	-	SIPRNET, LAN, brief, report
<b>IT-A</b>	-	-	-	-

**Figure 4.3 Redesign Alternative 1: Groupware**

increased performance (Frenzel, Jr. 1987, Russell and Norvig 1995, Turban and Aronson 1998 ). KBS are ideal for sharing and distributing key knowledge. For the BGTPP, the author focuses specifically on the application of expert systems (ES) and intelligent agents.

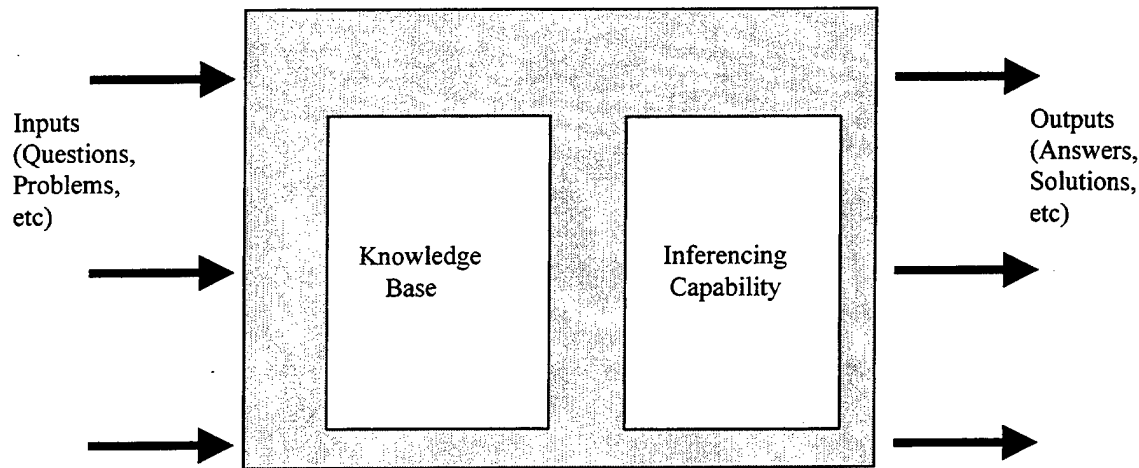
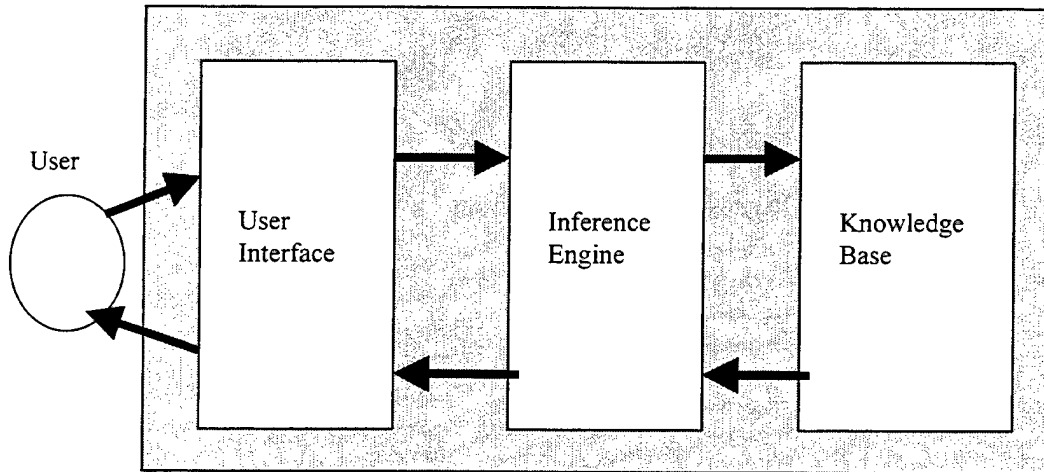

**Figure 4.4 Applying AI Concepts with a Computer (From Frenzel, Jr. 1987)**

First, the author discusses the application of expert systems (ES).

ES are programs that assist non-experts in making decisions comparable to an expert. An expert system emulates the interaction between the user and an expert in a specific domain (e.g., asking questions, making recommendations, explaining its logic). Unlike other KM technologies, which assume the user already possesses some knowledge about the subject, ES allow almost anyone to solve problems and make decisions in a subject area as well as an expert. ES capture part of an expert's decision-making knowledge, store it in a knowledge base, and allow its effective dissemination to users through an interface, Figure 4.5 (Frenzel, Jr. 1987, Liebowitz 1999, Russel and Norvig 1995).

Given that an expert system has a knowledge base and an inferencing capability, it can be used to assist the intelligence staff in conducting trend analysis. Prior to use, knowledge and expertise used to conduct trend analysis must be

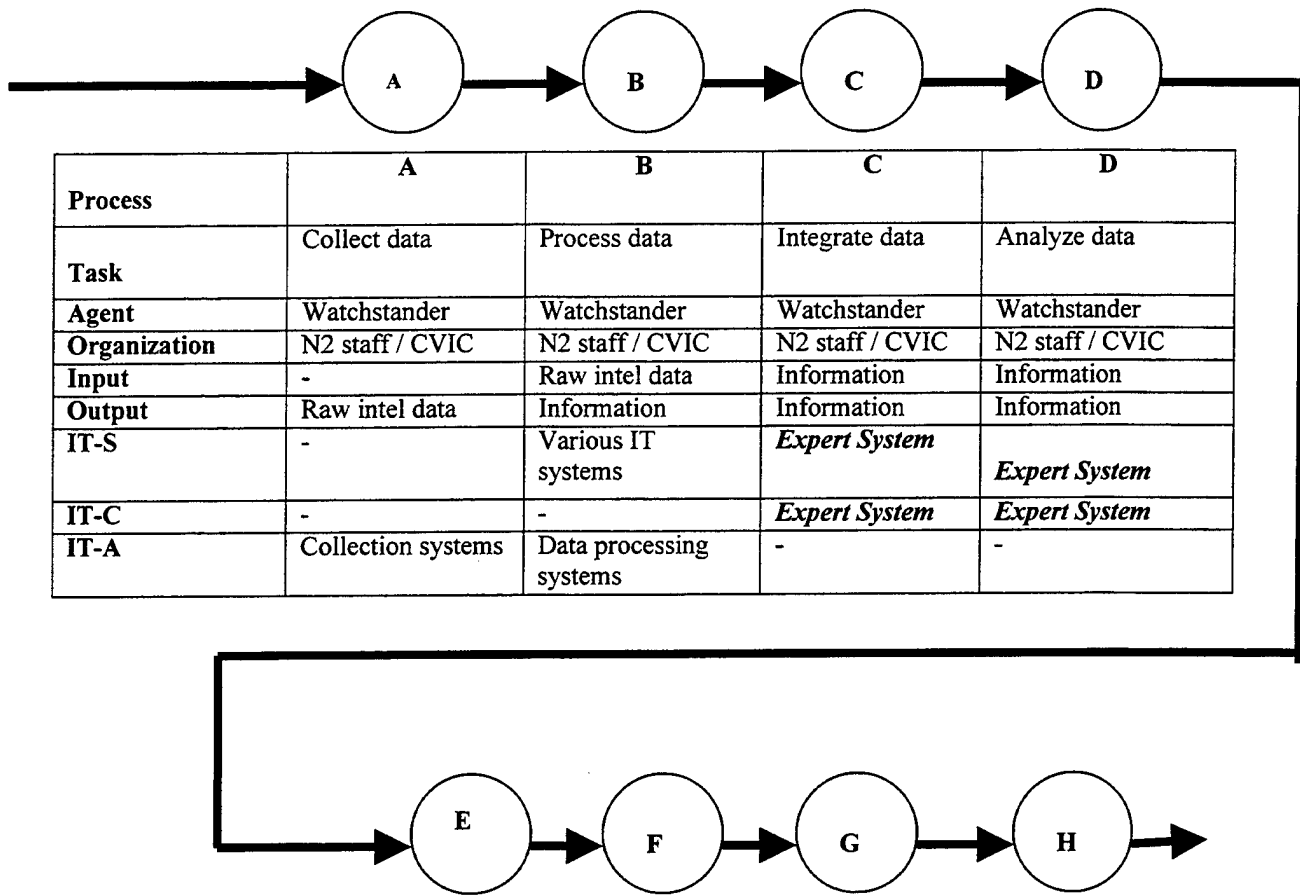

**Figure 4.5 General Block Diagram of an Expert System (From Frenzel, Jr. 1987)**

codified and stored in the expert system's knowledge base. Once operational, the expert system interacts and assists the user conducting trend analysis.

Figure 4.6 shows the redesign process incorporating an expert system in phases C through F. The expert system increases IT-S because it assists users with integrating, analyzing, evaluating, and interpreting data used in trend analysis. The application of an expert system also increases IT-C because it uses an interface to interact and provide the user with a solution.

Next, the author discusses the application of intelligent agents. Intelligent agents are computer programs that can act autonomously based on their environment, experience, and expertise. Intelligent agents are used to perform some human-oriented tasks and act on behalf of the user. An agent perceives its environment through sensors and acts upon it through effectors, Figure 4.7. When delegated with a new task by the user, the intelligent agent uses its knowledge base and cognitive skills to determine its goal, evaluates how the goal can be reached in an effective manner, and performs the necessary actions to reach the goal.



	A	B	C	D
<b>Process</b>				
<b>Task</b>	Collect data	Process data	Integrate data	Analyze data
<b>Agent</b>	Watchstander	Watchstander	Watchstander	Watchstander
<b>Organization</b>	N2 staff / CVIC	N2 staff / CVIC	N2 staff / CVIC	N2 staff / CVIC
<b>Input</b>	-	Raw intel data	Information	Information
<b>Output</b>	Raw intel data	Information	Information	Information
<b>IT-S</b>	-	Various IT systems	<i>Expert System</i>	<i>Expert System</i>
<b>IT-C</b>	-	-	<i>Expert System</i>	<i>Expert System</i>
<b>IT-A</b>	Collection systems	Data processing systems	-	-

	E	F	G	H
<b>Process</b>				
<b>Task</b>	Evaluate data	Interpret data	Produce intel product	Distribute intel pro product
<b>Agent</b>	Watchstander	Watchstander	N2 / Intelligence Analysis & Reporting Cell	N2 / Intelligence Analysis & Reporting Cell
<b>Organization</b>	N2 Staff / CVIC	N2 staff / CVIC	N2 staff / CVIC	N2 staff / CVIC
<b>Input</b>	Information	Information	Intelligence	Intel product
<b>Output</b>	Information	Intelligence	Intelligence product	Intel product
<b>IT-S</b>	<i>Expert System</i>	<i>Expert System</i>	Various IT tools (MS Office tools)	-
<b>IT-C</b>	<i>Expert System</i>	<i>Expert System</i>	-	SIPRNET, LAN, brief, report
<b>IT-A</b>	-	-	-	-

Figure 4.6 Redesign Alternative 2: Expert System

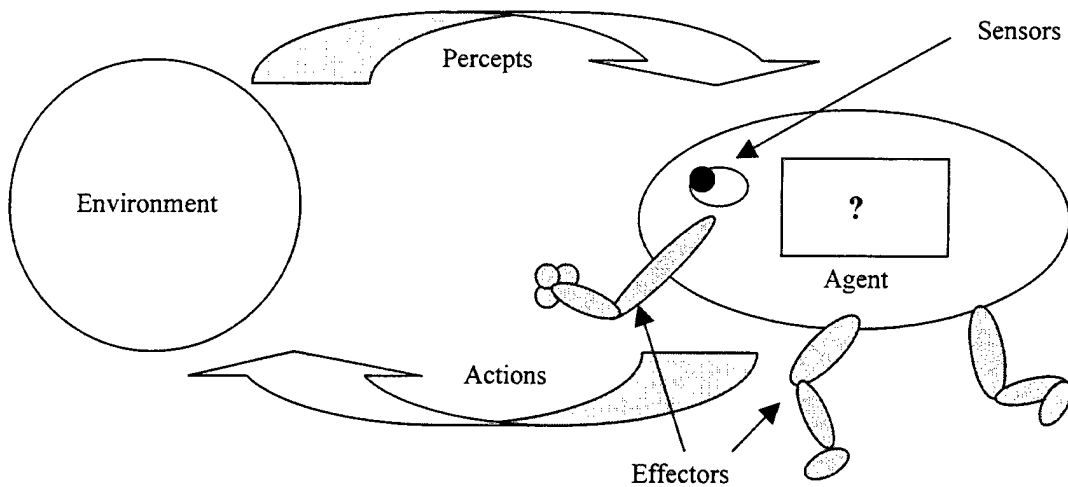

**Figure 4.7 Agent Interacting with Environment through Sensors and Effectors  
(From Russell and Norvig 1995)**

Given that an intelligent agent can perceive its environment through sensors and act upon it rationally through effectors, the intelligence staff can employ an intelligent agent to conduct trend analysis. Prior to operation, tacit knowledge used to conduct trend analysis must be codified and stored in the agent. Once data has been collected and processed, the agent can then conduct the intelligence analysis. Over time, the agent uses its knowledge, rationale, and experience to increase its efficacy at conducting trend analysis.

Figure 4.8 shows the redesign process incorporating an intelligent agent in phases C through F. Unlike the expert system, the intelligent agent automates these phases by integrating, analyzing, evaluating, and interpreting data itself. Therefore, employment of an intelligent agent increases IT-A. IT-C also increases because the agent must communicate its results to the user through an interface.

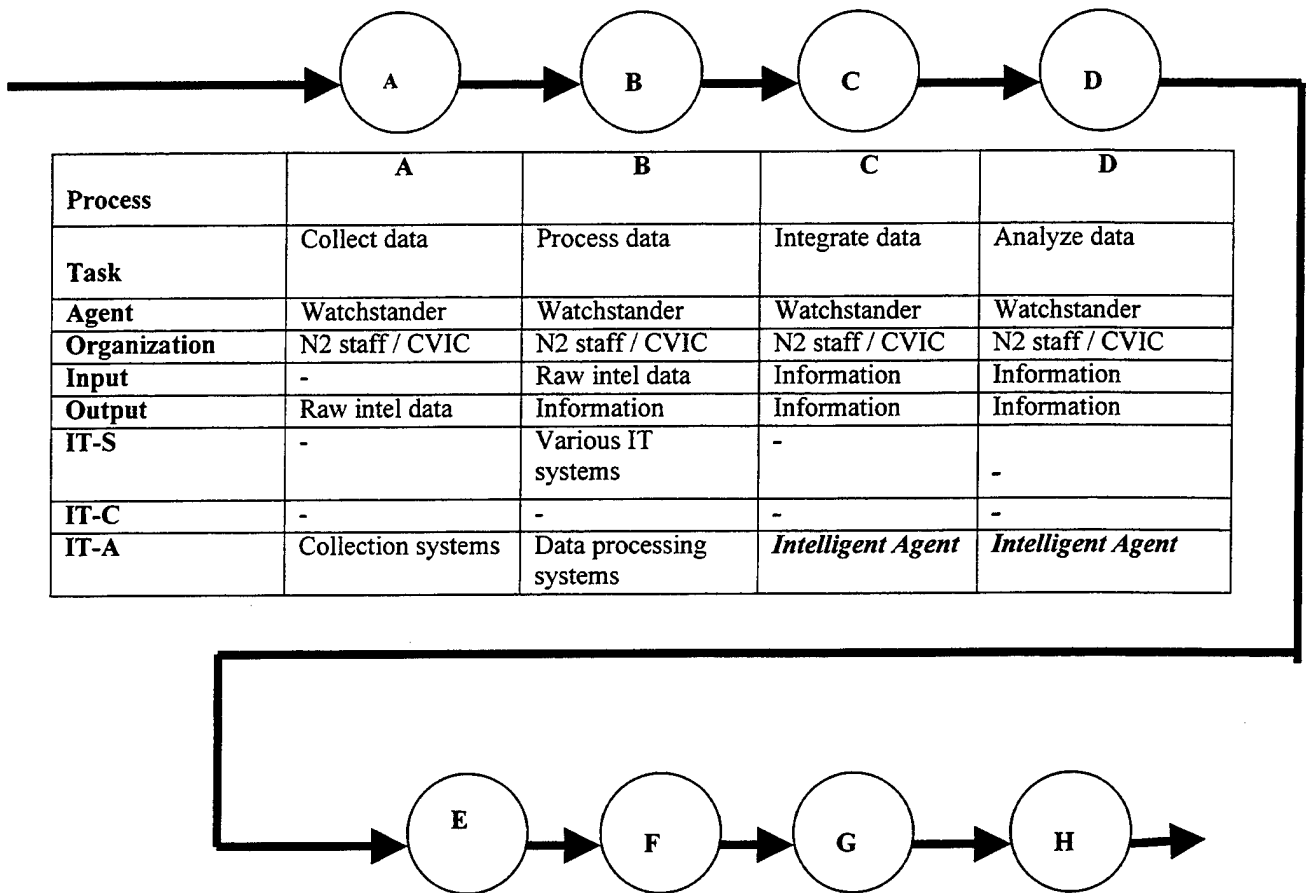

	A	B	C	D
<b>Process</b>				
<b>Task</b>	Collect data	Process data	Integrate data	Analyze data
<b>Agent</b>	Watchstander	Watchstander	Watchstander	Watchstander
<b>Organization</b>	N2 staff / CVIC	N2 staff / CVIC	N2 staff / CVIC	N2 staff / CVIC
<b>Input</b>	-	Raw intel data	Information	Information
<b>Output</b>	Raw intel data	Information	Information	Information
<b>IT-S</b>	-	Various IT systems	-	-
<b>IT-C</b>	-	-	-	-
<b>IT-A</b>	Collection systems	Data processing systems	<i>Intelligent Agent</i>	<i>Intelligent Agent</i>

	E	F	G	H
<b>Process</b>				
<b>Task</b>	Evaluate data	Interpret data	Produce intel product	Distribute intel pro product
<b>Agent</b>	Watchstander	Watchstander	N2 / Intelligence Analysis & Reporting Cell	N2 / Intelligence Analysis & Reporting Cell
<b>Organization</b>	N2 Staff / CVIC	N2 staff / CVIC	N2 staff / CVIC	N2 staff / CVIC
<b>Input</b>	Information	Information	Intelligence	Intel product
<b>Output</b>	Information	Intelligence	Intelligence product	Intel product
<b>IT-S</b>	-	-	Various IT tools (MS Office tools)	-
<b>IT-C</b>	-	<i>Intelligent Agent</i>	-	SIPRNET, LAN, brief, report
<b>IT-A</b>	<i>Intelligent Agent</i>	<i>Intelligent Agent</i>	-	-

**Figure 4.8 Redesign Alternative 2: Intelligent Agent**

### **3. Test Alternatives**

Now that the redesign transformations have been identified and applied to generate each redesign alternative, next the author analyzes each with KOPeR and compares the performance results with that of the current trend analysis process. The objective is to determine if each alternative treats the pathologies of the current process. After using KOPeR to diagnose each redesign alternative, the author compares the results to the current process.

In Table 4.2, process measures that vary across the redesigns are highlighted in bold. This promotes clarity and focuses the reader's attention on the differences between the process designs. Notice parallelism, handoffs fraction, and feedback fraction do not change. This reflects the IT focus of the author's three process redesigns. Groupware improves the IT-C fraction by providing a medium in which BGs can exchange knowledge, but the IT-S fraction remains the same because groupware does not support trend analysis. Alternatively, the expert system addresses pathologies through IT-S as well as IT-C, but it contributes nothing in terms of automating intelligence tasks. Conversely, the use of an intelligent agent significantly increases IT-A but fails to address the IT-S and IT-C pathologies.

### **4. Select Solution**

After diagnosing and comparing each redesign alternative to the current "as is" process, the next step is to select one alternative or a combination for implementation and process improvement. Based on the present technology available to fleet units, two solutions are generated. The solutions are near- and long-term. The near-

Measure	Current Process	Groupware	Expert System	Intelligent Agent
Process Length	8	8	8	8
Process Handoffs	2	2	2	2
Process Size	8	8	8	8
Process Feedback	1	1	1	1
IT Support	2	2	6	2
IT Communication	1	5	5	2
IT Automation	2	2	2	6
Parallelism	1.00	1.00	1.00	1.00
Handoffs Fraction	0.25	0.25	0.25	0.25
Feedback Fraction	0.125	0.125	0.125	0.125
IT Support Fraction	0.25	0.25	<b>0.75</b>	0.25
IT Communication Fraction	0.125	<b>0.625</b>	<b>0.625</b>	<b>0.25</b>
IT Automation Fraction	0.25	0.25	0.25	<b>0.75</b>

**Table 4.2 KOPeR Comparative Measures**

term solution focuses on a redesign alternative that can be easily implemented and is already an initiative underway. It incorporates an existing technology and applies it to the current BGTTP. The long-term solution combines redesign alternatives one and two, taking advantage of existing technology being implemented in the fleet and KBS.

For the near-term, the DoN should continue to employ groupware technology and apply it as an instrument to facilitate the exchange of tacit knowledge. Although it does not treat the IT-S pathology of the current process, groupware re-establishes a knowledge exchange medium, which was lost by replacing face-to-face turnovers with other IT communication methods. In addition, groupware technology is being successfully implemented within the STENNIS CVBG, and plans are underway to implement the same groupware technology within another CVBG. Overall, groupware is a near-term solution for process improvement.

However, groupware alone does not ensure knowledge transfer. By using groupware, the command assumes that the user knows where to look for knowledge or relies on personnel to share knowledge and contribute to the knowledge base. Searching for knowledge in a knowledge repository can be time consuming and result in a wasted effort because knowledge within the knowledge base is primarily text and indexed by keywords and their proximity to the text. This activity is a shallow aspect of knowledge and can be difficult to extract key knowledge. Also, if the command does not support knowledge sharing, then relying on personnel to share knowledge or contribute to the knowledge base is impractical (Davenport and Prusak 1998, Russell and Norving 1995, Frenzel, Jr. 1987).

In the long-term, an expert system should be developed as an overlay that interacts with the groupware's knowledge base. By using an expert system as an overlay, it can navigate through the knowledge base to find current key knowledge, then extract and use this key knowledge to support the user conducting trend analysis. Through this means, key knowledge is captured, stored, and shared.

## **5. Redesign Implementation**

This segment outlines a migration strategy to implement the selected solutions and manage organizational change. The migration strategy defines the action plan to transition from the current BGTTP to the desired process applying groupware and expert systems. To implement both solutions, organizational change is required. Both target technology for organizational change.

Although implementation consists of many activities, the author focuses primarily on solution installation and organizational issues regarding resistance to change. There are four types of installation strategies: 1) direct, the old system is turned off as the new system is turned on, 2) parallel, both old and new systems are operated together until the new system is ready to be used exclusively, 3) single location, one site is selected to test the new system, and 4) phased, the new system is installed in components (Hoffer, George, and Valacich 1999). Each strategy involves the conversion of software, data, potentially hardware, documentation, work methods, job descriptions, and other aspects of the system. Just as there are two recommended solutions, the author recommends two different installation strategies for each redesign implementation.

Currently, fleet units are applying a combination of parallel and single location isolation strategies to implement groupware technology. For example, the STENNIS BG is using groupware as a communication medium in parallel with other systems to facilitate knowledge exchange among units within the BG. The BG has not completely replaced other communication tools with groupware, but the transition is occurring as users become more comfortable with the tool and reliability increases. Because this combined installation strategy has proven effective in the STENNIS BG, the author recommends that fleet units continue to apply the same strategy demonstrated by the STENNIS BG. By employing this strategy, groupware is gradually phased in, BG by BG. Over time, a KM infrastructure will be created in which BGs use groupware to exchange knowledge amongst their own personnel and with other BGs; thereby, improving the BGTTP.

To implement the expert system, the author recommends a single location isolation strategy. Unlike groupware, which operates in parallel with other systems, the expert system is a new, stand-alone system designed to support the user conducting trend analysis. Employing an expert system for trend analysis is a new practice for the military and should be gradually phased in at a single command before it is implemented throughout the fleet. Data conversion, tool development, and required systems training are just a few time consuming issues supporting this recommendation. After the installation has been successful at one command, the expert system can be deployed to other fleet units. Once fleet units employ ES for trend analysis, one can expect BG situational awareness to increase. As a result, theater familiarization periods would in turn decrease; thus, improving the BGTTP.

However, as the redesign solutions are installed, there is likely to be some resistance to organizational change. In order to effectively manage organizational change and implement the solutions successfully, the following actions are required. First, senior leadership must support the redesign and be committed to it. This step is the most critical. Senior leadership must understand the existing problem and how the redesign solves it. They must also be willing to allocate resources supporting the redesign and undergo some organizational transformation to align the redesign with the command's structure and core competencies. Next, the command must be committed to change. This requires creating a knowledge-oriented culture. The command should be willing to change behaviors, procedures, and possibly other aspects of the organization to produce a knowledge-creating and sharing environment that supports the redesign. But often, successful system implementation depends on user application and satisfaction. In order to achieve both, the user should be involved in the development process. If each of the preceding requirements is met accordingly, this can ensure a key migration step is met in order to align the command with the redesign. A redesign solution in alignment with the command mission and objective is more likely to be successfully implemented and succeed (Hoffer, George, and Valacich 1999, Davenport and Prusak 1998, Brooking 1999).

## **B. KNOWLEDGE PERFORMANCE MEASURES**

In this section, the author identifies possible knowledge performance measures to rate success after the selected solution has been implemented. In comparison with traditional labor-based industries, measuring knowledge work has proven difficult because knowledge work is intangible. For knowledge workers, the inputs and outputs

are intangibles, which cannot be quantified (Liebowitz 1999). Because of this difficulty, other qualitative measures must be used to determine success (Davenport and Prusak 1998).

Ideally, if the BGTTP's primary objective is achieved, there will be no noted transition as CVBGs periodically rotate in and out of the Gulf. However, in reality, this is not the case. Today, CVBGs continually require time to acclimate to the Gulf environment and increase situational awareness. Because of these reoccurring issues, the author recommends BG theater familiarization periods, situational awareness, and BG efficacy as knowledge performance measures.

If tacit knowledge is effectively captured and transferred between BGs operating in the Arabian Gulf, the author envisions a reduction in theater familiarization periods, increased situational awareness, and increased efficacy between CVBGs. By sharing a knowledge base common to all BGs operating in the Gulf, BG staffs would have access to knowledge and expertise acquired by Gulf operations, which differs greatly from the explicit knowledge gained by re-creating a knowledge base. As a result, situational awareness should increase. As situational awareness increases, theater familiarization periods decrease. Thus, the final result is the arriving BG, on day one, performing as well as if it was on the departing BG's 90<sup>th</sup> day of operation in the Arabian Gulf. Because of the difficulty in measuring knowledge work, these performance measures are purely qualitative. Continued or additional research is required to determine more effective means of measuring knowledge transfer in the BGTTP.

### C. KNOWLEDGE MANAGEMENT IN NETWORK-CENTRIC WARFARE (NCW)

In this section, the author discusses how the same KM concept used to improve the BGTP can be applied to NCW warfighting value chain, Figure 4.9, to share and disseminate knowledge. The two main NCW principles are speed of command and self-synchronization. As stated in Chapter II, speed of command is defined by decisively altering initial conditions to lock in success while locking out alternative enemy strategies. Self-synchronization is defined as the ability of a well-informed force to organize and synchronize complex warfare activities from the bottom up.

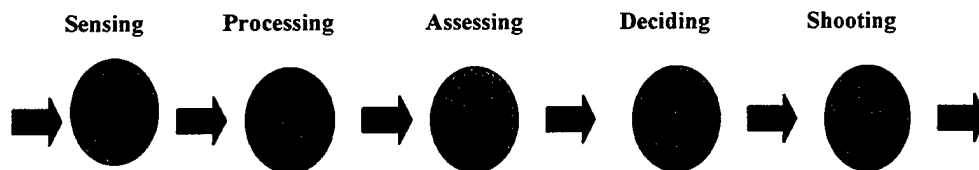
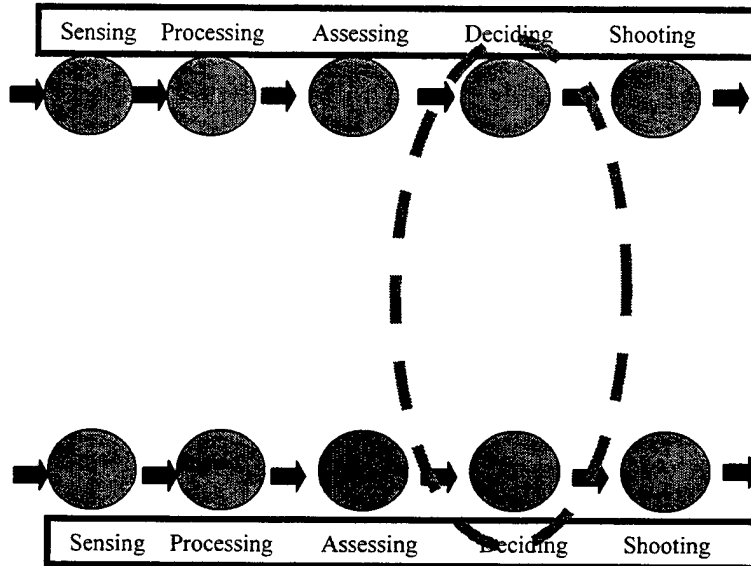

**Figure 4.9 NCW Warfighting Value Chain**

Recalling the NCW warfighting value chain process, the first three processes, sensing, processing, and assessing, are automated, while the remaining processes, deciding and shooting, require action by military personnel. Both require proven knowledge gained from experience in combat to make NCW successful. To execute the NCW principles and support decision making, a well-informed network sharing knowledge, not just data, is essential. Commanders must not only have information but knowledge of how to apply it to make decisions. Knowledge acquired from combat experience must be shared so the best decisions are made the first time and that self-synchronization becomes a reality.

In order to do so, NCW must employ a KM tool that captures, stores, and shares key knowledge acquired from combat experience to make well-informed decisions in

today and tomorrow's military operating environment, Figure 4.10. Similar to this thesis, additional research must be conducted to evaluate the warfighting value chain process for process improvement and possible redesign.



**Figure 4.10 Knowledge Capture and Transfer between Warfare Commanders in the NCW Warfighting Value Chain**

#### D. SUMMARY

Although there are many IT tools available supporting KM, the author selected knowledge repositories and KBS as his primary means to treat pathologies identified in the current trend analysis process. Of the author's three redesign alternatives, groupware and ES were selected for implementation because both increased the IT-S and IT-C fractions, thus improving process performance overall. Although groupware is the easiest to implement and presents minimum impact on current operations, it does not ensure knowledge exchange. To capture, store, and share key knowledge used in trend analysis, an expert system is the preferred KM tool. By employing the KM tools noted

above, naval intelligence can continue to provide key intelligence support and ensure the arriving BG is truly ready for duty on day one.

THIS PAGE INTENTIONALLY LEFT BLANK

## V. CONCLUSIONS AND RECOMMENDATIONS

Chapter V summarizes the purpose and content of this thesis. It includes conclusions drawn from analyzing the current Battle Group Theater Transition Process (BGTTTP) and the redesign alternatives selected to improve the BGTTTP's process performance. The author concludes this chapter by proposing areas for additional future research and a final thought.

### A. SUMMARY

As the United States Navy continues to support the naval strategic concept *Forward...From the Sea*, one of the Navy's primary objectives continues to be forward presence and power projection to deter any actions that may threaten U.S. interests, specifically in the Arabian Gulf. In this theater, the Department of the Navy (DoN) employs the carrier battle group (CVBG) as the principle element of U.S. national power projection capability. The CVBG's peacetime mission is to conduct forward presence operations to help shape the strategic environment by deterring conflict, building interoperability, and by responding, as necessary, to fast breaking crises with the demonstration and application of credible combat power (OPNAV Instruction 3501.316 1995).

Since the conclusion of the Gulf War, the DoN has periodically rotated carrier battle groups (CVBG) from the Atlantic and Pacific fleets into this theater. During each deployment, the CVBG remains on station for three months in theater and is replaced by another CVBG, which conducts a successive, three-month deployment on station. The transition from one CVBG to another in theater is facilitated by the BGTTTP. The BGTTTP's primary objective is to transfer knowledge between the CVBGs to reduce the

arriving battle group's theater familiarization period so it can effectively respond to any indications & warnings (I&W) and engage a potential threat accordingly if the immediate need arises.

At a time when the Gulf environment is frequently hostile, changing rapidly, and uncertain, the need to decrease CVBG theater familiarization periods is intense. The current BGTP provides the arriving battle group with explicit, theater, background information, but the experience and tacit knowledge gained through operations by the departing battle group may not be transferred in the process. Recent developments in information technology (IT) help facilitate the transition process, but only data and information are transferred at present, not knowledge. The author's thesis goal is to improve the BGTP's performance by applying Nissen, Kamel, and Sengupta's knowledge management (KM) design process to create a KM system that effectively captures and transfers tacit knowledge between battle groups; therefore, significantly reducing the arriving battle group's theater familiarization period to a minimum.

## **B. CONCLUSIONS**

Of the many processes included in the BGTP, the author identified and selected trend analysis as the target process for redesign. KOPeR analysis revealed the current "as is" process had some pathologies, which suggest performance implications. Further, the KOPeR analysis revealed the current process was sequential, but with acceptable handoffs, feedback, and automation. However, the process lacked adequate IT support and communication. This indicated that IT was not being used to conduct trend analysis or share key knowledge involved. Overall, the current trend analysis process can be

viewed as an informal, defective process not capable of supporting robust knowledge exchange between CVBGs.

### **C. RECOMMENDATIONS**

Based on the KOPeR diagnosis, the author selected IT as the process transformation to improve performance. Even though there are several IT tools supporting KM, knowledge repositories and knowledge-based systems (KBS) were the selections of choice because both technologies capture, store, and share knowledge. Each redesign alternative treats the pathologies identified in the KOPeR diagnosis by either providing a means to share tacit knowledge used in trend analysis through discussion or by providing a mechanism that conducts trend analysis and shares knowledge indirectly.

The author recommends that the Navy continue to implement alternative one, groupware, because it is already an initiative underway and creates the foundation for alternative two, expert systems. Groupware serves as an instrument to facilitate the exchange of tacit knowledge, which was lost by replacing face-to-face turnovers with other IT communication methods. Currently, groupware is the easiest alternative to implement and imposes minimum impact on current operations while improving process performance. Today, the application of groupware technology is evident in the Pacific Fleet and has been successfully implemented in the USS JOHN C. STENNIS battle group. This same concept can be applied to other CVBGs, thus creating a KM infrastructure.

In addition to groupware, the author further recommends that expert systems be employed to capture and retain key knowledge and prevent knowledge loss caused by

attrition and high turnover rates. By applying expert systems, knowledge for trend analysis can be preserved and remain available to users for years to come.

#### **D. FUTURE RESEARCH**

The topics presented below are potential areas that require future research. These areas are not addressed in this thesis due to time and scope limitations. Nonetheless, these topics should be addressed to support and improve the BGTTP. The author recommends two major fields of study for future research.

##### **1. Other BGTTP KM Applications**

Within the BGTTP, several battle group counterparts conduct turnover processes to facilitate a smooth transition between CVBGs. The turnover process conducted between battle group intelligence staffs for trend analysis is just an example. But there are other battle group missions and functions that require the effective transfer of knowledge. Recalling the composite warfare commander (CWC) concept, each warfare commander has a specific mission and requires key knowledge to successfully accomplish this mission. In order to ensure that the arriving battle group is prepared for any emerging crisis, on day one of operations in the Arabian Gulf, key knowledge acquired by operating in the Gulf must be captured and shared. The author recommends that the Navy research and identify other turnover processes within the BGTTP with KM implications. By effectively sharing knowledge between all counterparts, battle group theater familiarization periods may be reduced to a minimum.

## **2. Other KM Applications**

Throughout the course of this research, the author asked two questions outside this thesis scope regarding the BGTTP: “Why is the Navy conducting turnover this way?” and “Can it be done better?” More specifically:

- Is there a more effective means, besides the current BGTTP, to share key knowledge of Gulf operations? Reduce BG theater familiarization periods?
- What are the advantages of utilizing a knowledge portal to facilitate knowledge exchange vice the BGTTP?

Researching these topics may identify other alternatives that improve knowledge exchange and better prepare the arriving BG for duty on day one in the Gulf.

### **E. FINAL THOUGHTS**

As the DoN continues to deploy the CVBG as a national security instrument in the Arabian Gulf and support *Forward...From The Sea*, naval intelligence will encounter new challenges daily as the global environment rapidly changes, naval operations increasingly focus on littoral regions, and weapons proliferation increases. In such a dynamic environment, the responsibilities of naval intelligence remain the same. With these new challenges, naval intelligence is still expected to do its part in the BGTTP by increasing situational awareness to reduce theater familiarization periods. The redesign alternatives presented in this thesis, if implemented, offer good potential to improve the BGTTP's performance and reduce theater familiarization periods. By employing these alternatives, naval intelligence can continue to provide key intelligence support to the BG and DESRON commanders and ensure the arriving BG is truly ready for duty, on day one, in the Gulf.

THIS PAGE INTENTIONALLY LEFT BLANK

## LIST OF REFERENCES

Alter, S., *Information Systems: A Management Perspective*, 2<sup>nd</sup> ed, Benjamin/Cummings Publishing, 1996.

Boorda, J. M., Dalton, J. H., and Mundy, C. E. Jr., *Forward...From The Sea*, 1992.

Brooking, A., *Corporate Memory: Strategies for Knowledge Management*, International Thomson Business Press, 1999.

Cebrowski, A. K. and Garstka, J. J., "Network-Centric Warfare: Its Origin and Future," *Naval Institute Proceedings*, January 1998.

Davenport, T. H., "Business Process Reengineering: Where It's Been, Where It's Going," *Business Process Change* Reengineering Concepts, Methods, and Technologies, Grover, V. and Kettinger, W., eds., pp. 1-13, Hershey, Pa., Idea Group Publishing, 1995.

Davenport, T. H., DeLong, D. W., and Beers, M. C., "Successful Knowledge Management Projects." *Sloan Management Review*, 39, pp. 43-57, 1998.

Davenport, T. H. and Prusak, L., *Working Knowledge: How Organizations Manage What They Know*, Boston, Harvard Business School Press, 1998.

Despres, C. and Chauvel, D., "Mastering Information Management: Part Six-Knowledge Management," *Financial Times*, March 8, pp. 4-6, 1999.

FIFTH FLEET Web site, <http://www.cusnc.navy.mil/alist/info2.htm>, 2000.

Forbes, Special Focus on Intellectual Capital, *Forbes ASAP*, 1997.

Glazer, R., "Measuring the Knower: Towards a Theory of Knowledge Equity," *California Management Review* 40(3), pp. 175-194, 1998.

Frenzel, Jr., L. E., *Crash Course in Artificial Intelligence and Expert Systems*, Indianapolis, In., Howard W. Sams & Co., 1987.

Gartner Group, "Knowledge Management Scenario," Conference presentation, SYM8KnowMan1098Kharris, 1999.

Hibbard, J. "Knowing What We Know," *Information Week*, vol. 20, pp. 46-64, 1997.

Hoffer, J. A., George, J. F., and Valacich, J. S., *Modern Systems Analysis & Design*, 2<sup>nd</sup> ed., Addison Wesley Longman, Inc., 1998.

Lenci, M. "Collaborating at Sea: A Domino Based Carrier Battle Group Solution," Conference presentation, 2000.

Liebowitz, J., ed. *Knowledge Management Handbook*, Washington, D. C.: CRC Press, 1999.

Naval Doctrine Publication 2, *Naval Intelligence*, 1994.

Nissen, M. E., "Redesigning Reengineering through Measurement-Driven Inference," *MIS Quarterly* 22(4), pg 509-534, 1998.

Nissen, M. E., Kamel, M., and Sengupta, K., "Integrated Analysis and Design of Knowledge Systems and Processes," *Information Resources Management Journal*, Jan-Mar 2000, pp. 24-43, 2000.

Nonaka, I., "A Dynamic Theory of Organizational Knowledge Creation," *Organization Science* 5(1), pp. 14-37, 1994.

OPNAV Instruction 3501.316. Policy For Carrier Battle Groups. 1995.

Russel, S. and Norvig, P., *Artificial Intelligence: A Modern Approach*, Prentice-Hall, Inc., 1995.

Shen, S., "Knowledge Management in Decision Support Systems," *Decision Support Systems* 3, pp. 1-11, 1987.

Srikantaiah, T. K. and Koenig, M. E. D., *Knowledge Management for the Information Professional*, Information Today, Inc., 1999.

Teece, D. J., "Firm Organization, Industrial Structure, and Technological Innovation," *Journal of Economic Behavior and Organization* 31(2), pp. 193-224, 1996.

Tobin, D., *Transformational Learning: Renewing Your Company through Knowledge and Skills*, John Wiley & Sons, 1996.

Turban, E. and Aronson, J. E., *Decision Support Systems and Intelligent Systems*, 5<sup>th</sup> ed., Prentice-Hall, Inc., 1998.

United States Army Command & General Staff College, *Battle Book / ST 100-3*, Ft. Leavenworth, Kansas, 1999.

United States Naval Reserve Intelligence Program, *Ready-for-Sea Modular Course & Handbook*, San Diego, California, Reserve Intelligence Area Four, 1999.

Webber, A. M., "What's So New About the New Economy?" *Harvard Business Review*, January-February 1993.

## INITIAL DISTRIBUTION LIST

1. Defense Technical Information Center.....2  
8725 John J. Kingman Road, Suite 0944  
Ft. Belvoir, VA 22060-6218
2. Dudley Knox Library.....2  
Naval Postgraduate School  
411 Dyer Road  
Monterey, CA 93943-5101
3. Network-Centric Innovation Center .....6  
3420 Guadacanal Road, Building 16  
San Diego, CA 92155
4. Commander-in-Chief, United States Pacific Fleet.....2  
Attention: LT E. Oxendine, Directorate for Intelligence (N2)  
250 Makalapa Drive  
Pearl Harbor, HI 96860-3131
5. Dr. Mark E. Nissen.....1  
Naval Postgraduate School  
555 Dyer Road, Code SM/Ni  
Monterey, CA 93943-5000
6. Dr. Carl R. Jones.....1  
Professor of Information Systems  
Naval Postgraduate School  
Monterey, CA 93943
7. Dr. Dan Boger .....1  
Chair, IS Academic Group  
Code IS  
Naval Postgraduate School  
Monterey, Ca 93943