

# LOAN DOCUMENT

PHOTOGRAPH THIS SHEET

DTIC ACCESSION NUMBER

LEVEL

INVENTORY

*Bioventing Pilot Test Work...*

DOCUMENT IDENTIFICATION

*MAY 94*

**DISTRIBUTION STATEMENT A**  
Approved for Public Release  
Distribution Unlimited

DISTRIBUTION STATEMENT

ACCESSION FOR	
NTIS	GRAM <input checked="" type="checkbox"/>
DTIC	TRAC <input type="checkbox"/>
UNANNOUNCED JUSTIFICATION	
BY	
DISTRIBUTION/	
AVAILABILITY CODES	
DISTRIBUTION	AVAILABILITY AND/OR SPECIAL
<i>A-1</i>	

DISTRIBUTION STAMP

DATE ACCESSIONED

DATE RETURNED

20001214 010

DATE RECEIVED IN DTIC

REGISTERED OR CERTIFIED NUMBER

H  
A  
N  
D  
L  
E  
  
W  
I  
T  
H  
  
C  
A  
R  
E

PHOTOGRAPH THIS SHEET AND RETURN TO DTIC-FDAC

# DRAFT

**Bioventing Pilot Test Work Plan For  
Facilities 1748, 44625D, and 44625E  
Cape Canaveral AFS, Florida**

## PART II

**Draft Interim Pilot Test Results Report for  
Facilities 1748, 44625D, and 44625E  
Cape Canaveral AFS, Florida**

Prepared For

**Air Force Center for Environmental Excellence  
Brooks AFB, Texas**

and

**45 CES/CEV  
Patrick AFB, Florida**

**ES**

**Engineering-Science, Inc.**

May 1994

1700 BROADWAY, SUITE 900  
DENVER, COLORADO 80290

ES ENGINEERING-SCIENCE

AQM01-03-0431

### DEFENSE TECHNICAL INFORMATION CENTER REQUEST FOR SCIENTIFIC AND TECHNICAL REPORTS

Title AFCEE Collection

**1. Report Availability** (Please check one box)

- This report is available. Complete sections 2a - 2f.
- This report is not available. Complete section 3.

**2a. Number of Copies Forwarded**

1 each

**2b. Forwarding Date**

July/2000

**2c. Distribution Statement** (Please check ONE box)

*DoD Directive 5230.24, "Distribution Statements on Technical Documents," 18 Mar 87, contains seven distribution statements, as described briefly below. Technical documents MUST be assigned a distribution statement.*

- DISTRIBUTION STATEMENT A:** Approved for public release. Distribution is unlimited.
- DISTRIBUTION STATEMENT B:** Distribution authorized to U.S. Government Agencies only.
- DISTRIBUTION STATEMENT C:** Distribution authorized to U.S. Government Agencies and their contractors.
- DISTRIBUTION STATEMENT D:** Distribution authorized to U.S. Department of Defense (DoD) and U.S. DoD contractors only.
- DISTRIBUTION STATEMENT E:** Distribution authorized to U.S. Department of Defense (DoD) components only.
- DISTRIBUTION STATEMENT F:** Further dissemination only as directed by the controlling DoD office indicated below or by higher authority.
- DISTRIBUTION STATEMENT X:** Distribution authorized to U.S. Government agencies and private individuals or enterprises eligible to obtain export-controlled technical data in accordance with DoD Directive 5230.25, Withholding of Unclassified Technical Data from Public Disclosure, 6 Nov 84.

**2d. Reason For the Above Distribution Statement** (in accordance with DoD Directive 5230.24)

**2e. Controlling Office**

HQ AFCEE

**2f. Date of Distribution Statement Determination**

15 Nov 2000

**3. This report is NOT forwarded for the following reasons.** (Please check appropriate box)

- It was previously forwarded to DTIC on \_\_\_\_\_ (date) and the AD number is \_\_\_\_\_
- It will be published at a later date. Enter approximate date if known. \_\_\_\_\_
- In accordance with the provisions of DoD Directive 3200.12, the requested document is not supplied because: \_\_\_\_\_

Print or Type Name

Laura Peña

Telephone

210-536-1431

Signature

Laura Peña

(For DTIC Use Only)

AQ Number

M01-03-0431

**PART I**  
**BIOVENTING PILOT TEST WORK PLAN FOR**  
**FACILITIES 1748, 44625D, AND 44625E**

**CAPE CANAVERAL AFS, FLORIDA**

**November 1993**

**Prepared for:**

**Air Force Center for Environmental Excellence**  
**Brooks AFB, Texas**

**and**

**45 CES/CEV**  
**Patrick AFB, Florida**

**Prepared by:**

**Engineering-Science, Inc.**  
**1700 Broadway, Suite 900**  
**Denver, Colorado 80290**

## TABLE OF CONTENTS

1.0 Introduction.....	1
2.0 Site Description .....	2
2.1 Location and History.....	2
2.1.1 Location and History for Facility 1748 .....	2
2.1.2 Location and History for Facilities 44625D and 44625E.....	6
2.2 Site Geology.....	6
2.2.1 Geology for Facility 1748 .....	6
2.2.2 Geology for Facilities 44625D and 44625E .....	10
2.3 Site Contaminants.....	10
2.3.1 Contaminants for Facility 1748.....	10
2.3.2 Contaminants for Facilities 44625D and 44625E.....	10
3.0 Pilot Test Activities.....	11
3.1 Introduction .....	11
3.2 Well Siting and Construction .....	11
3.2.1 Well Siting and Construction for Facility 1748 .....	11
3.2.2 Well Siting and Construction for Facilities 44625D and 44625E .....	13
3.3 Handling of Soil Boring Cuttings and Excavated Soils.....	18
3.4 Soil and Soil Gas Sampling .....	18
3.4.1 Soil Sampling .....	18
3.4.2 Soil Gas Sampling .....	19
3.5 Air Monitoring .....	19
3.6 Blower System .....	19
3.7 <i>In Situ</i> Respiration Test.....	19
3.8 Air Permeability Test.....	21
3.9 Installation of Extended Pilot Test Bioventing System .....	21
4.0 Exceptions to Protocol Procedures .....	21
5.0 Base Support Requirements.....	22
5.1 Test Preparation .....	22
6.0 Project Schedule.....	23

7.0 Points of Contact.....	24
8.0 References.....	24

## FIGURES

Figure 2.1 Facility 1748 Site Plan.....	3
Figure 2.2 Facility 1748 Soil Gas Survey Locations.....	4
Figure 2.3 Facilities 44625D and 44625E Site Plan.....	7
Figure 2.4 Facilities 44625D and 44625E Soil Gas Survey Locations.....	8
Figure 3.1 Facility 1748 Bioventing Pilot Test Site Plan.....	12
Figure 3.2 Proposed Injection Vent Well Construction.....	14
Figure 3.3 Monitoring Point Construction Detail.....	15
Figure 3.4 Facilities 44625D and 44625E Bioventing Pilot Test Site Plan .....	16
Figure 3.5 Blower System Instrumentation Diagram for Air Injection .....	20

## TABLES

Table 2.1 Soil Gas Survey Results, Facility 1748.....	5
Table 2.2 Soil Gas Survey Results, Facilities 44625D and 44625E.....	9

## DRAFT

### BIOVENTING TEST WORK PLAN FOR FACILITY 1748 (BASE CAFETERIA) AND FACILITY 44625D AND FACILITY 44625E (GENERATOR MAINTENANCE SHOP) CAPE CANAVERAL AFS, FLORIDA

#### 1.0 INTRODUCTION

This site-specific work plan presents the scope of multi-phase bioventing pilot tests for *in-situ* treatment of fuel-contaminated soils at the base cafeteria, designated as Facility 1748 and two contaminated areas at the generator maintenance shop, designated as Facility 44625D and 44625E at Cape Canaveral Air Force Station (AFS), Florida. The proposed pilot tests will be performed by Engineering-Science, Inc. (ES). The three primary objectives of the proposed pilot tests are: 1) to assess the potential for supplying oxygen throughout the contaminated soil depth within the unsaturated zone, 2) to determine the rate at which indigenous microorganisms will degrade the fuel when stimulated by oxygen-rich soil gas, and 3) to evaluate the potential for sustaining these rates of biodegradation until fuel contamination is remediated to concentrations below regulatory standards.

If bioventing proves to be a feasible technology for these sites, pilot test data may be used to design a full-scale remediation system and to estimate the time required for remediating soils to regulatory standards. An added benefit expected from the pilot testing at these areas is that a significant amount of the fuel contamination should be biodegraded during the 1-year pilot test, as the testing will take place within the most contaminated soils that have been detected at the site.

The pilot tests will utilize one vertical air injection vent well (VW) at each facility. Each site will be equipped with a blower capable of sustaining a flow rate of 20 to 40 standard cubic feet per minute (scfm). VW tests typically produce an effective radius of influence of approximately 20 to 40 feet. The design air injection rate and actual radius of influence for the sites will depend on soil properties and other factors. Rates of *in situ* fuel biodegradation will be determined for individual soil vapor monitoring points (VMPs) that will be installed around the VWs.

Additional background information on the development and recent success of the bioventing technology is found in the protocol document entitled *Test Plan and*

*Technical Protocol for a Field Treatability Test for Bioventing* (Hinchee et. al. 1992). This protocol document is a supplement to the site-specific work plan and it will also serve as the primary reference for pilot test VW and VMP designs, and detailed test objectives and procedures. Unless otherwise noted, test procedures outlined in the protocol document will be used during the pilot test at Facilities 1748, 44625D, and 44625E.

## **2.0 SITE DESCRIPTION**

### **2.1 Location and History**

#### **2.1.1 Location and History for Facility 1748**

Facility 1748 (the base cafeteria) is located on Hangar Road within the industrial area on CCAFS (Figure 2.1). This facility has been in operation since 1958. A 4,000-gallon underground diesel fuel tank was installed in 1958 to fuel the boilers used by the base cafeteria and remained in service until March 1992.

A Phase I Assessment conducted in March 1992 at Facility 1748 in the vicinity of the out-of-service 4,000-gallon diesel underground storage tank (UST) indicated the presence of hydrocarbon soil contamination in the area adjacent to the UST (CH<sub>2</sub>M Hill, 1992). Figure 2.2 depicts the estimated limits of excessively contaminated soil above the water table in the vicinity of the UST location at Facility 1748, as determined during the March 1992 assessment. Excessive soil contamination was determined using the guidelines approved by the State of Florida in accordance with the Florida Administrative Code (F.A.C.) Chapter 17-770. The study also indicated, based on interviews with station personnel, that the petroleum contamination was likely a result of historical overfilling of the tank. The significant hydrocarbon soil contamination found at this site is the primary target for bioventing treatment.

A soil gas survey was conducted by ES at Facility 1748 in July 1993. A 20x25-foot grid was laid out in the field where previous sampling determined significant hydrocarbon soil contamination. Oxygen (O<sub>2</sub>), carbon dioxide (CO<sub>2</sub>), and total volatile petroleum hydrocarbon (TVPH) measurements were collected at depths of 2.5 and 5.0 feet below ground surface (bgs), at five grid locations. Based on the results of the survey, significant soil contamination still exists within the area surveyed. Figure 2.2 presents the soil gas survey point locations. Table 2.1 presents the results of the soil gas survey.

Figure 2.1

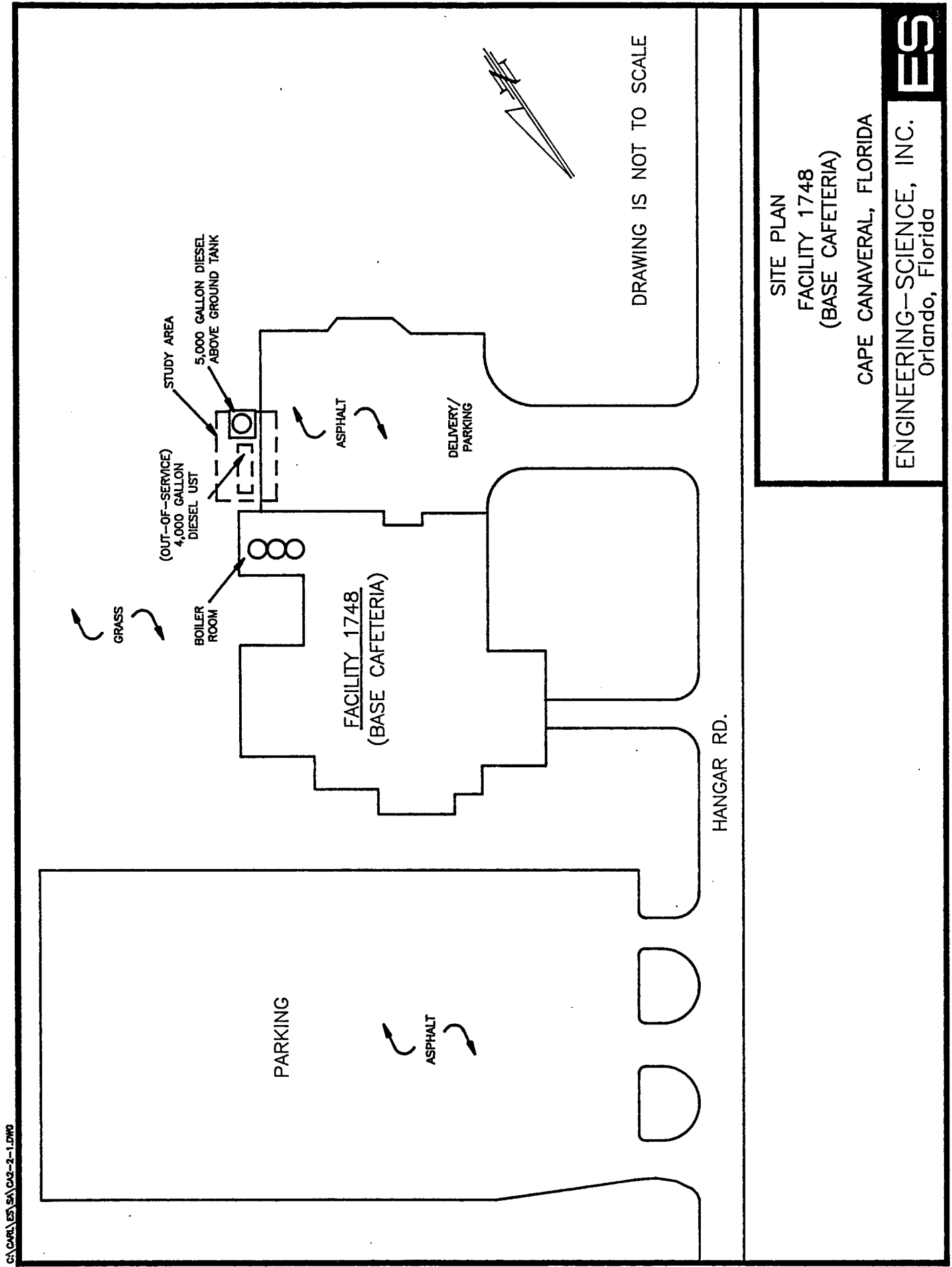

SITE PLAN  
 FACILITY 1748  
 (BASE CAFETERIA)  
 CAPE CANAVERAL, FLORIDA  
 ENGINEERING-SCIENCE, INC.  
 Orlando, Florida



Figure 2.2

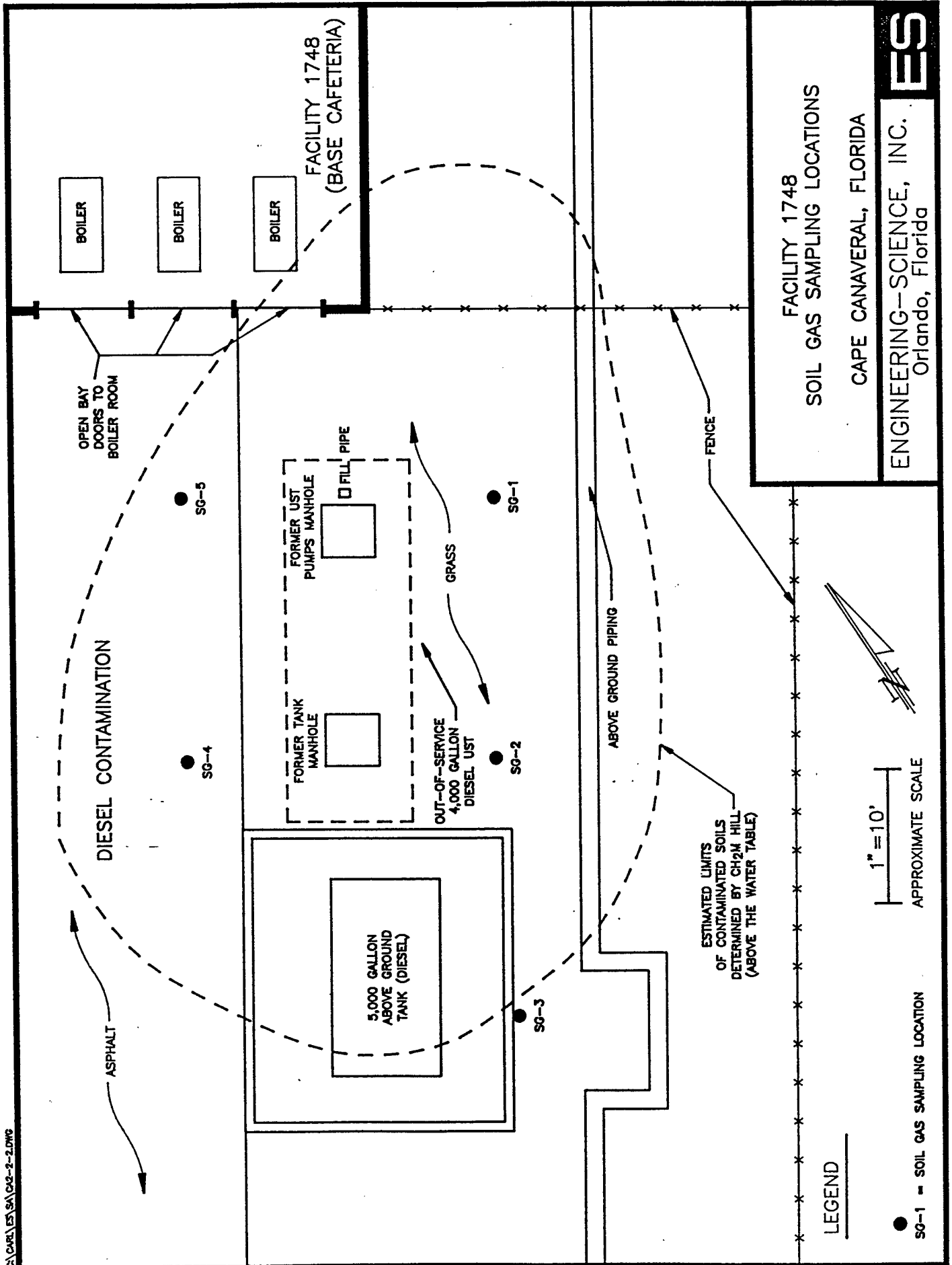

C:\CARE\ES\SA\02-2-2.DWG

TABLE 2.1  
SOIL GAS SURVEY RESULTS  
FACILITY 1748  
CAPE CANAVERAL AIR FORCE STATION, FLORIDA

Date	Soil Gas Test Point	Depth (feet bgs) <sup>a/</sup>	O <sub>2</sub> (percent)	CO <sub>2</sub> (percent)	TVPH Concentration (ppmv) <sup>b/</sup>	Remarks
July 1993	SG-1	2.5	8.2	10.0	240	Water table ~ 6.5 ft bgs
	SG-2	5.0	0.5	16.0	1,600	
		2.5	7.8	10.2	260	
	SG-3	5.0	0.0	16.5	360	
		2.5	17.0	3.3	140	
SG-4	5.0	15.9	3.9	140		
	2.5	0.0	16.0	16,600		
SG-5	5.0	0.0	16.5	>20,000		
	2.5	0.0	17.5	>20,000		
		5.0	0.0	18.0	>20,000	

a/ Below ground surface (bgs)

b/ TVPH = Total volatile petroleum hydrocarbons; ppmv = parts per million, volume per volume

### **2.1.2 Location and History for Facilities 44625D and 44625E**

Facilities 44625D and 44625E (generator maintenance facility) is located within the industrial area on CCAFS (Figure 2.3). These facilities have been in operation since 1974. According to Base personnel a 1,000-gallon underground waste oil tank was installed in 1965 adjacent to Facility 44625D.

A Phase I Assessment was conducted in January, 1992 at Facilities 44625D and 44625E in the vicinity of the former 1,000-gallon underground waste oil tank. Results from the assessment indicated the presence of hydrocarbon soil contamination in the area adjacent to the tank. Figure 2.4 depicts the estimated limits of visually-stained soil, above the water table, at Facilities 44625D and 44625E (CH<sub>2</sub>M Hill, 1992).

According to the Phase I report, the 1,000-gallon underground waste oil tank was removed in August 1991 and replaced with an above-ground waste oil tank. According to station personnel, a visually stained seam of soil was evident along the northeast face of the open excavation during the tank removal. Station personnel also reported that the ground surface in this area had been subject to numerous past surface spills and leaks of petroleum products (CH<sub>2</sub>M Hill, 1992). The presence of hydrocarbon soil contamination, like that found at this site, is the primary target for bioventing treatment.

A soil gas survey was conducted by ES at Facilities 44625D and 44625E in July, 1993. Eight total soil gas locations were sampled; four locations associated with Facility 44625D and four at Facility 44625E. All soil gas sampling locations were located within the areas where previous sampling indicated visually stained hydrocarbon soil contamination. Oxygen (O<sub>2</sub>), carbon dioxide (CO<sub>2</sub>), and total volatile petroleum hydrocarbon (TVPH) measurements were collected at depths of 2.5 and 5.0 feet bgs at all eight soil gas locations. Based on the results of the survey, significant soil contamination still exists within the two areas surveyed. Figure 2.4 presents the soil gas survey point locations. Table 2.2 presents the results of the soil gas survey which show anaerobic soil conditions and indicate a need for bioventing..

## **2.2 Site Geology**

### **2.2.1 Geology for Facility 1748**

Because the bioventing technology is applied to the unsaturated soils, this section will primarily address soils above the shallow aquifer. Soils at this site and to a depth of 40 feet bgs consist of predominantly unconsolidated, moderately well-sorted, fine-to-course-grained quartz sand with few to many shell fragments.

Figure 2.3

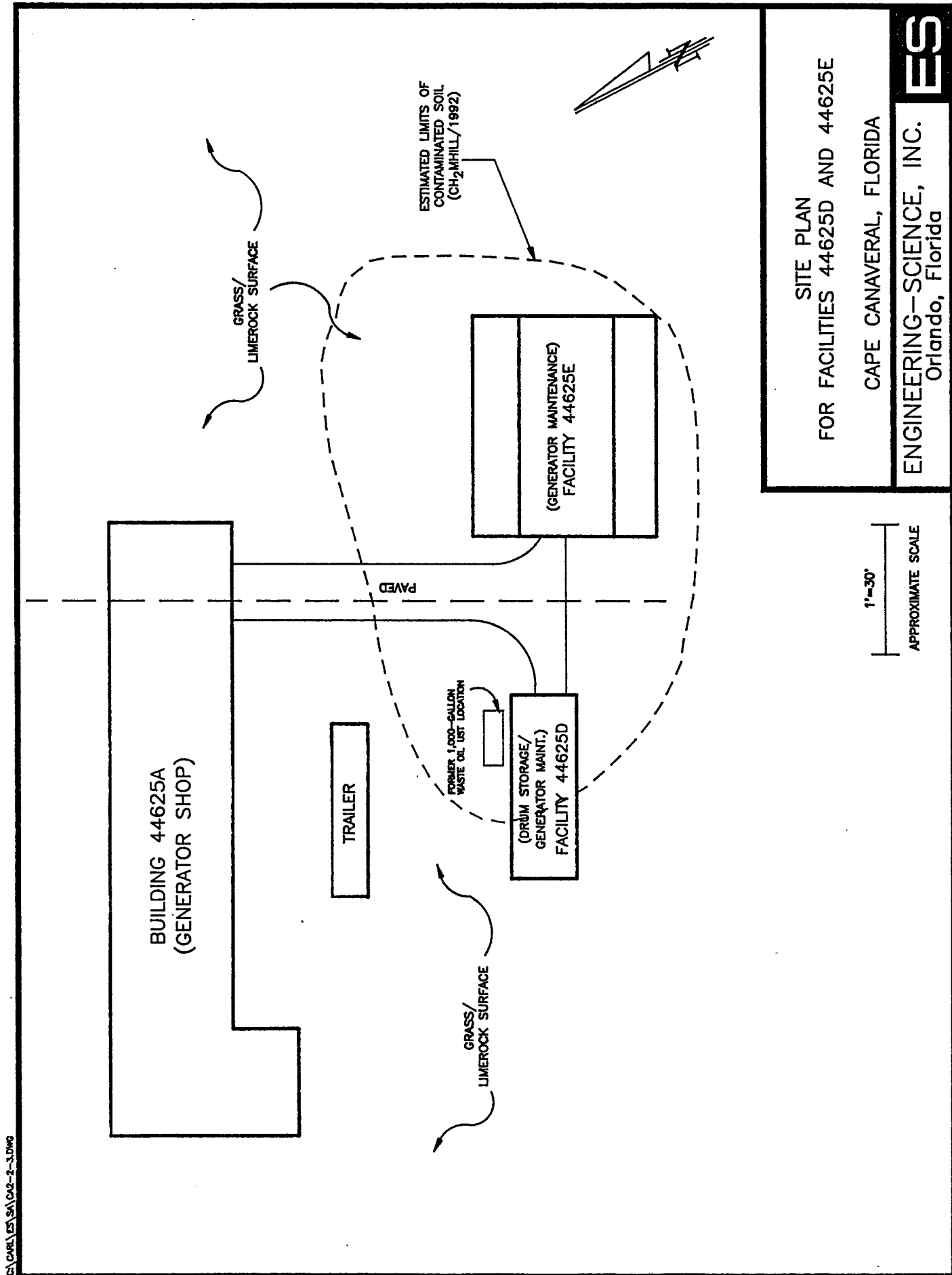
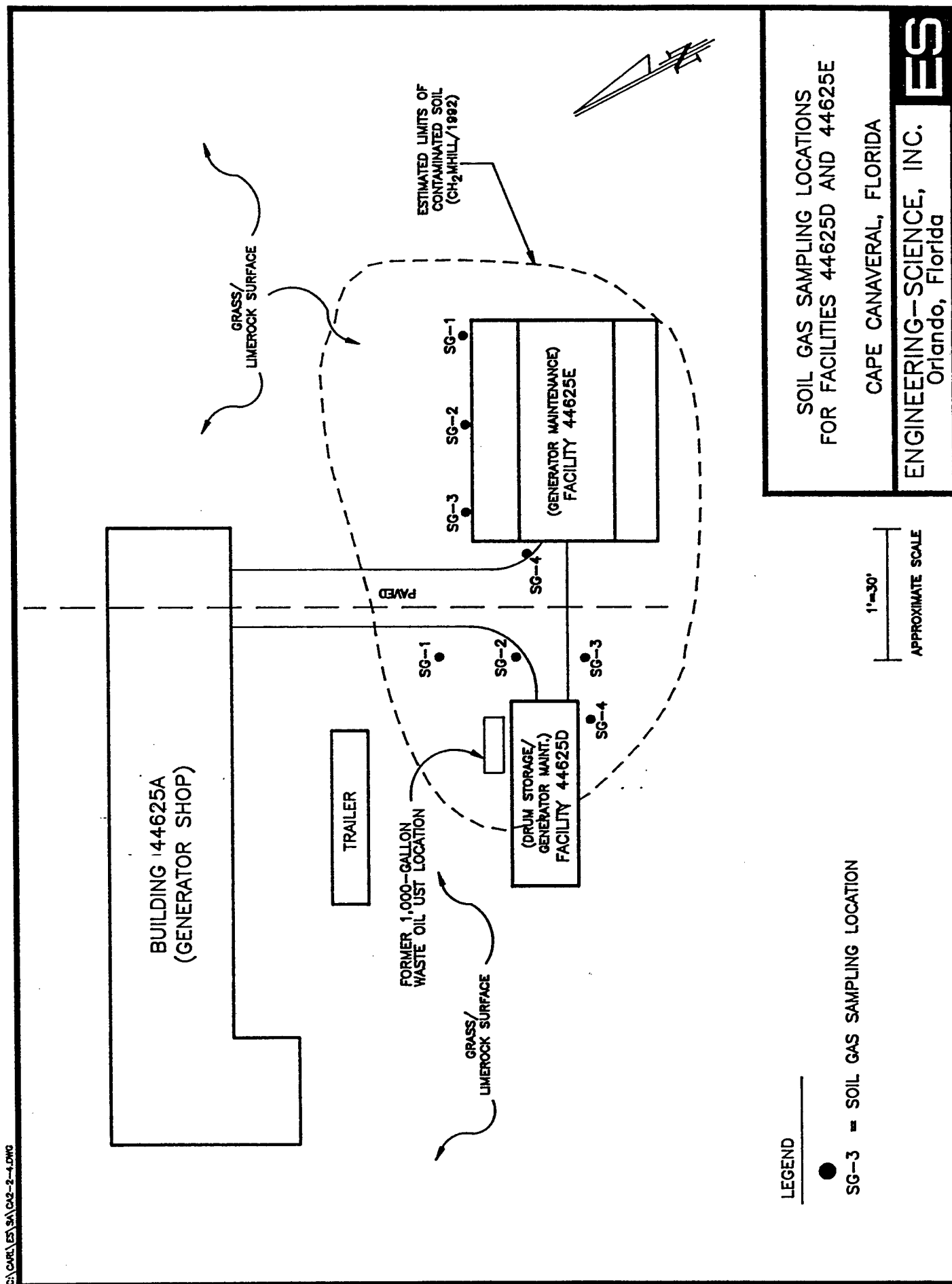

Figure 2.4



C:\CARE\ES\9A\C02-2-4.DWG

SOIL GAS SAMPLING LOCATIONS  
FOR FACILITIES 44625D AND 44625E

CAPE CANAVERAL, FLORIDA

ENGINEERING-SCIENCE, INC.  
Orlando, Florida



TABLE 2.2  
 SOIL GAS SURVEY RESULTS  
 FACILITY 44625D and 44625E  
 CAPE CANAVERAL AIR FORCE STATION, FLORIDA

Date	Soil Gas Test Point	Depth (feet bgs) <sup>a/</sup>	O <sub>2</sub> (percent)	CO <sub>2</sub> (percent)	TVPH Concentration (ppmv) <sup>b/</sup>	Remarks
Facility 44625D July 1993	SG-1	2.5	12.8	6.8	200	Water table ~ 6.5 ft bgs
		5.0	0.0	15.5	440	
	SG-2	2.5	2.7	13.5	280	
		5.0	0.0	16.0	880	
Facility 44625E July 1993	SG-3	2.5	0.0	15.0	2,200	Water table ~ 6.5 ft bgs
		5.0	0.0	15.0	2,200	
	SG-4	2.5	0.0	14.8	2,800	
		5.0	0.0	15.0	2,200	
Facility 44625E July 1993	SG-1	2.5	0.0	15.0	280	Water table ~ 6.5 ft bgs
		5.0	0.0	16.0	880	
	SG-2	2.5	0.0	15.0	14,600	
		5.0	0.0	16.0	14,800	
Facility 44625E July 1993	SG-3	2.5	3.5	12.2	360	Water table ~ 6.5 ft bgs
		5.0	0.0	15.8	6,400	
	SG-4	2.5	0.0	14.7	4,200	
		5.0	0.0	15.0	5,600	

a/ Below ground surface (bgs)

b/ TVPH = Total volatile petroleum hydrocarbons; ppmv = parts per million, volume per volume

Groundwater is encountered at fluctuating depths of approximately 6 to 8 feet across the site. The generally homogeneous, sandy material at this site appears to be well suited to bioventing treatment.

### **2.2.2 Geology for Facilities 44625D and 44625E**

Because the bioventing technology is applied to the unsaturated soils, this section will primarily address soils above the shallow aquifer. Soils at this site and to a depth of 40 feet bgs consist of predominantly unconsolidated, moderately well-sorted, fine-to-course-grained quartz sand with up to 40 percent shells and shell fragments. Groundwater is encountered at fluctuating depths of approximately 6 to 8 feet. The generally homogeneous, sandy material at this site appears to be well suited to bioventing treatment.

## **2.3 Site Contaminants**

### **2.3.1 Contaminants for Facility 1748**

The primary contaminants at Facility 1748 are petroleum hydrocarbons (diesel fuel), which have been detected in the soils above the shallow aquifer. Excessively contaminated soils have been detected in the surface soils sampled at a depth between 2 and 6 feet bgs. Samples from the 1991 soil borings collected in the vicinity of the out-of-service diesel UST and above the shallow aquifer showed excessively contaminated soil concentrations ranging from 100 parts per million (ppm) to > 1,000 ppm. The soil samples, collected during the Phase I Assessment, were screened in the field for petroleum hydrocarbons using an organic vapor analyzer (OVA), equipped with a flame ionization detector (FID). Soil contaminated by diesel fuel is considered to be excessively contaminated if the concentration of total hydrocarbon vapor from a headspace analysis is 50 ppm or greater when using an OVA-FID (CH<sub>2</sub>M Hill, 1992).

### **2.3.2 Contaminants for Facilities 44625D and 44625E**

The primary contaminants at Facilities 44625D and 44625E are petroleum hydrocarbons, which have been detected in the soils above the shallow aquifer. Excessively contaminated soil was observed during a preliminary soils investigation conducted in 1991. Samples from the 1991 soil borings collected in the vicinity of the former 1,000-gallon waste oil tank and in the unsaturated soils showed elevated headspace concentrations of total hydrocarbons ranging from 64 ppmv to >1,000 ppmv. The soil samples were screened in the field using an OVA-FID (CH<sub>2</sub>M Hill, 1992). Soil contaminated by waste oil is considered excessively contaminated when it appears petroleum saturated by visually observable staining.

### **3.0 PILOT TEST ACTIVITIES**

#### **3.1 Introduction**

The purpose of this section is to describe the proposed location for one VW and three VMPs at each of the following facilities: 1748, 44625D, and 44625E. Soil sampling procedures and the blower configuration that will be used to inject air (oxygen) into the contaminated soils are also discussed in this section. Pilot test activities will be confined to the unsaturated soils. No dewatering will take place during the pilot tests. Existing monitoring wells located in uncontaminated soils which have a portion of their screened interval above the water table may be used as a background monitoring point (MP) to measure the composition of background soil gas.

#### **3.2 Well Siting and Construction**

##### **3.2.1 Well Siting and Construction for Facility 1748**

A general description of criteria for siting the VW and associated VMPs are included in the protocol document. Figure 3.1 illustrates the proposed location of the VW and VMPs at Facility 1748. These locations were selected based on previous analytical data collected at the site, and the soil gas survey conducted in July 1993.

The analytical data shows elevated hydrocarbon contamination extending from ground surface to the groundwater table in the vicinity of the out-of-service 4,000-gallon diesel UST. This area is expected to have a high average TPH concentration, based on previous soil sampling in the area. The soil gas survey conducted in this area showed the soils to be oxygen depleted (<2%), contain high TVPH concentrations (>20,000 ppmv) and elevated CO<sub>2</sub> (>15%). Increased biological activity should be stimulated by oxygen-rich soil gas ventilation during pilot test operations. Final location of the VWs may vary slightly from the proposed locations if significant soil contamination is not observed during the well installation boring.

Due to the relatively shallow depth of unsaturated soil contamination at this site (<8 feet bgs) and the potential for moderately permeable soil conditions, the radius of venting influence around the VWs is expected to approach 40 feet. A total of three VMPs will be located within a 10-foot, 20-foot, and 30-foot radius of the VW.

Figure 3.1

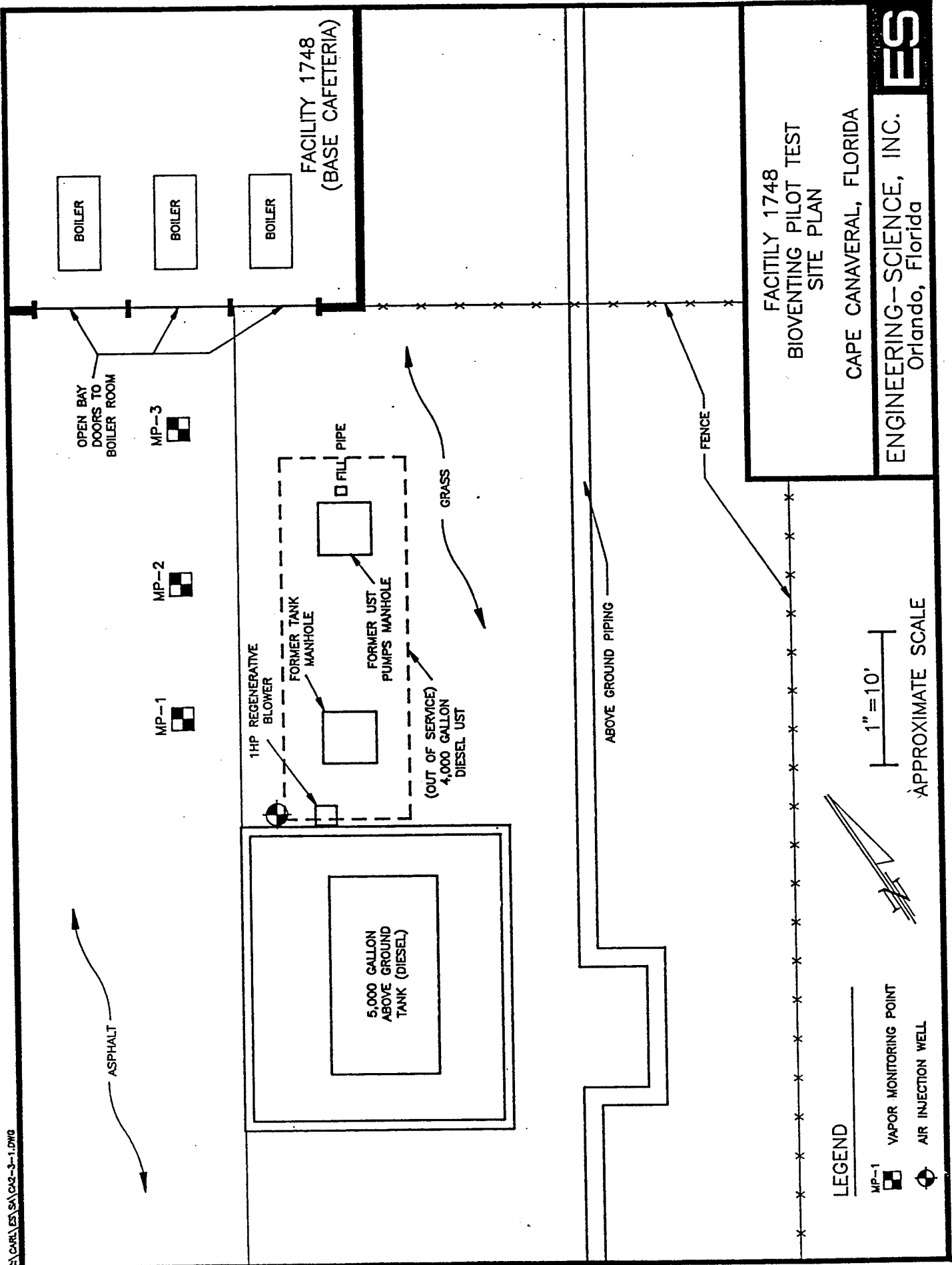

CA\CARL\ES\SA\CA2-3-1.DWG

Additionally, the well will be used to determine if natural carbon sources are contributing to oxygen uptake during the *in situ* respiration test. Additional details on the *in situ* respiration test are found in Section 5.7 of the protocol document.

The VW will be constructed of 4-inch inside diameter Schedule 40 PVC, with a five foot interval of 0.03 slotted screen set between 3 and 8 feet bgs (the deepest seasonal groundwater elevation expected). Flush-threaded PVC casing and screen will be used with no organic solvents or glues. The filter pack will be clean, graded 6/20 course silica sand, and will be placed in the annular space of the screened interval. A 2-foot layer of bentonite will be placed directly over the filter pack. The first foot of bentonite will consist of bentonite pellets hydrated in place with potable water. This layer of pellets will prevent the addition of the bentonite slurry from saturating the filter pack. The remaining one foot of bentonite will be fully hydrated and mixed above ground and the slurry tremied into the annular space to produce an air tight seal above the screened interval. Then, a one foot layer of cement/bentonite grout will be placed on top of the bentonite slurry to complete the seal to ground surface. A complete seal is critical to prevent injected air from short-circuiting to the surface during the bioventing test. Figure 3.2 illustrates the proposed VW construction details for this site.

A typical single-depth vapor monitoring point (VMP) installation for this site is shown in Figure 3.3. Because of the rather shallow depth to groundwater, only one air monitoring point will be required for each location. Soil gas oxygen and carbon dioxide concentrations will be monitored at a depth interval of approximately 3.0 to 3.5-feet at each location. Monitoring will confirm that the soil is receiving sufficient oxygen and will be used to measure fuel biodegradation rates. As with the VW, several inches of bentonite pellets will be used to shield the filter pack from rapid infiltration of bentonite slurry additions. Additional details on VW and monitoring point construction are found in Section 4 of the protocol document.

### **3.2.2 Well Siting and Construction for Facility 44625D and 44625E**

A general description of criteria for siting the VW and associated VMPs are included in the protocol document. Figure 3.4 illustrates the proposed location of the VW and VMPs at Facilities 44625D and 44625E. These locations were selected based on available analytical data and the soil gas survey conducted in July 1993.

The analytical data shows elevated hydrocarbon contamination extending from ground surface to the groundwater table in the vicinity of each facility. This area is expected to have a high average TPH concentration, based on previous soil

Figure 3.2

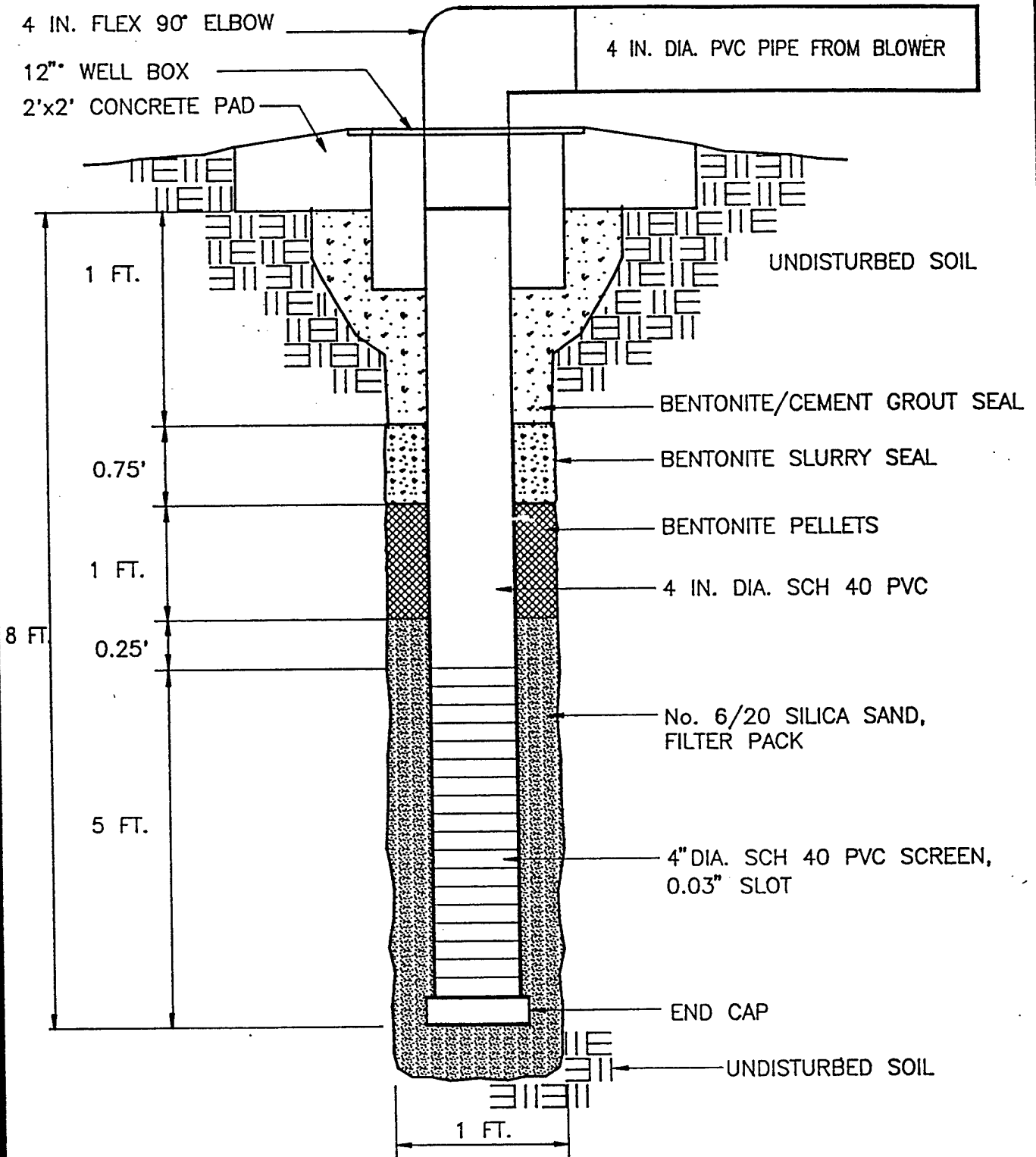

NOT TO SCALE

PROPOSED INJECTION VENT  
WELL CONSTRUCTION DETAIL

CAPE CANAVERAL, FLORIDA

ENGINEERING—SCIENCE, INC.  
Orlando, Florida



CS:\CAMS\ES\SA\02-3\_32.DWG

Figure 3.3

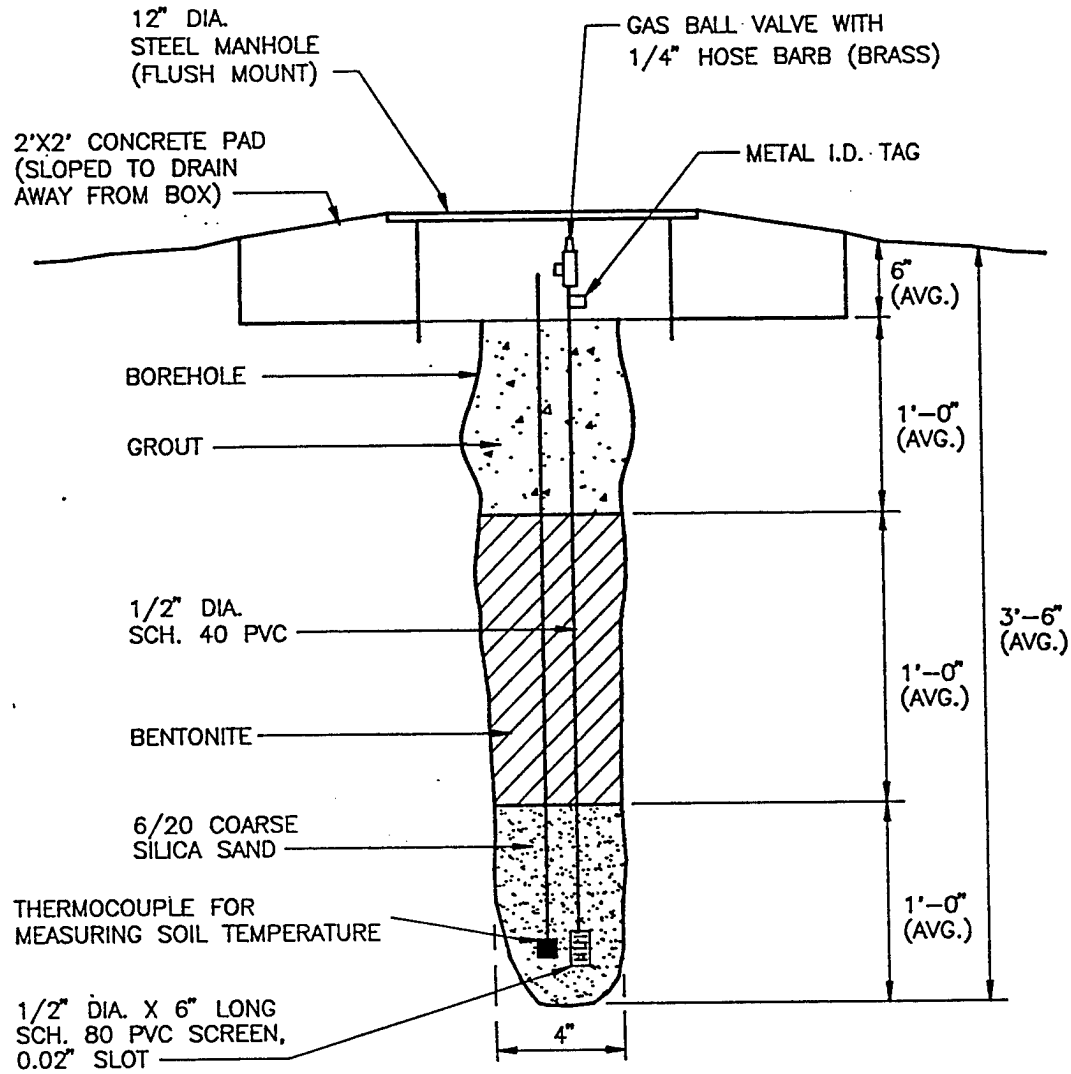

DRAWING IS NOT TO SCALE

PROPOSED MONITORING POINT  
CONSTRUCTION DETAIL

CAPE CANAVERAL, FLORIDA

ENGINEERING-SCIENCE, INC.  
Orlando, Florida



CAPE CANAVERAL ES/BA/C02-1.33.DWG

Figure 3.4

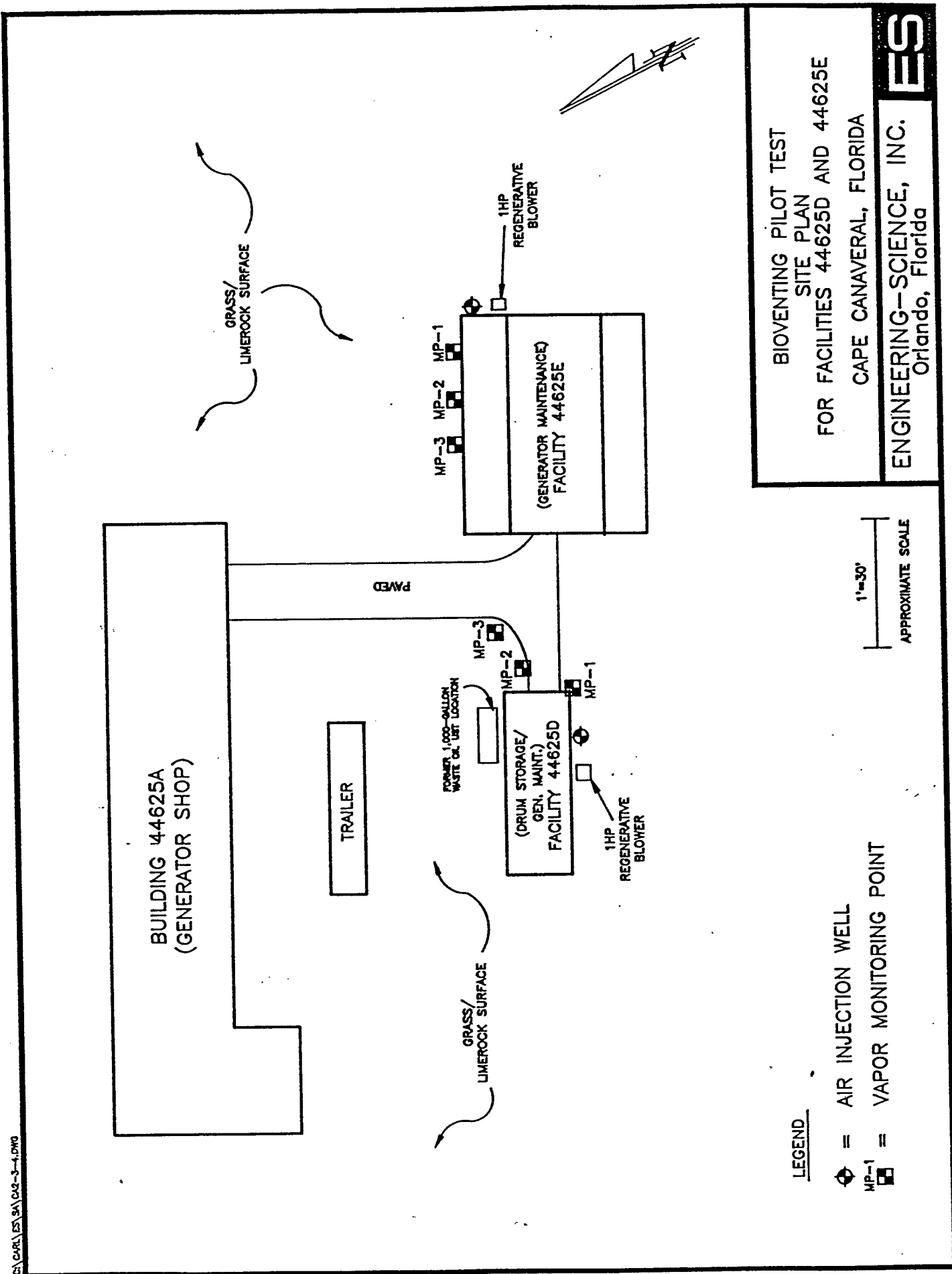

BIOVENTING PILOT TEST  
 SITE PLAN  
 FOR FACILITIES 44625D AND 44625E  
 CAPE CANAVERAL, FLORIDA  
**ENGINEERING-SCIENCE, INC.**  
 Orlando, Florida



CS:\CARL\ESA\CA2-3-1.DWG

sampling in the area. The soil gas survey conducted in this area showed the soils to be oxygen depleted (<2%), contain high TVPH concentrations (>2,000 ppmv at Facility 44625D and >14,000 ppmv at Facility 44625E) and elevated CO<sub>2</sub> (>12%). Increased biological activity should be stimulated by oxygen-rich soil gas ventilation during pilot test operations. Final location of the VWs may vary slightly from the proposed locations if significant soil contamination is not observed during the well installation boring.

Due to the relatively shallow depth of unsaturated soil contamination at this site (<8 feet bgs) and the potential for moderately permeable soil conditions, the radius of venting influence around the VWs is expected to approach 40 feet. A total of three VMPs will be located within a 10-foot, 20-foot, and 30-foot radius of the VW. A single permanent background monitoring point will be installed in uncontaminated soils to measure background levels of oxygen and carbon dioxide. Additionally, the single background well will be used by all three sites to determine if natural carbon sources are contributing to oxygen uptake during the *in situ* respiration test. Additional details on the *in situ* respiration test are found in Section 5.7 of the protocol document.

The VW will be constructed of 4-inch inside diameter Schedule 40 PVC, with a five foot interval of 0.03 slotted screen set between 3 and 8 feet bgs (the deepest seasonal groundwater elevation expected). Flush-threaded PVC casing and screen will be used with no organic solvents or glues. The filter pack will be clean, graded 6/20 course silica sand, and will be placed in the annular space of the screened interval. A 2-foot layer of bentonite will be placed directly over the filter pack. The first foot of bentonite will consist of bentonite pellets hydrated in place with potable water. This layer of pellets will prevent the addition of the bentonite slurry from saturating the filter pack. The remaining one foot of bentonite will be fully hydrated and mixed above ground and the slurry tremied into the annular space to produce an air tight seal above the screened interval. Then, a one foot layer of cement/bentonite grout will be placed on top of the bentonite slurry to complete the seal to ground surface. A complete seal is critical to prevent injected air from short-circuiting to the surface during the bioventing test. Figure 3.2 illustrates the proposed VW construction details for this site.

A typical single-depth vapor monitoring point (VMP) installation for this site is shown in Figure 3.3. Because of the rather shallow depth to groundwater, only one air monitoring point will be required for each location. Soil gas oxygen and carbon dioxide concentrations will be monitored at a depth interval of approximately 3.0 to 3.5-feet at each location. Monitoring will confirm that the soil is receiving sufficient

oxygen and will be used to measure fuel biodegradation rates. As with the VW, several inches of bentonite pellets will be used to shield the filter pack from rapid infiltration of bentonite slurry additions. Additional details on VW and monitoring point construction are found in Section 4 of the protocol document.

### **3.3 Handling of Soil Boring Cuttings and Excavated Soils**

Cuttings from all soil borings and any remaining waste soils will be collected in a Department of Transportation (DOT)-approved container. The containers will be labeled and then placed in a designated Cape Canaveral AFS hazardous materials storage area. These waste soils will become the responsibility of Cape Canaveral AFS and will be analyzed, handled, and disposed of in accordance with the current procedures for ongoing remedial investigations. This project is expected to generate less than four 55-gallon drums of waste soils.

### **3.4 Soil and Soil Gas Sampling**

#### **3.4.1 Soil Sampling**

A total of three soil samples will be collected from each of the pilot test areas during the installation of the VWs and VMPs. Sampling procedures will follow those outlined in the protocol document, with minor modifications for the collection of one sample from the most contaminated interval of the VW installation. One sample will be collected from the interval of highest apparent contamination in two of the borings for the VMPs at each facility. Soil samples will be analyzed for TRPH, BTEX, soil moisture, pH, particle sizing, alkalinity, total iron, and nutrients.

Samples will be obtained by hand augering to the desired sampling depth and then collecting the required volume of soil directly from the hand auger bucket. A photoionization detector (PID) or total hydrocarbon vapor analyzer (see protocol document Section 4.5.2) will be used to screen the hand auger cuttings for intervals of high fuel contamination. Additionally, the PID will be used to ensure that breathing-zone levels of volatiles do not exceed 1 part per million, per volume (ppmv) while conducting soil borings and well installations. Soil samples collected will be immediately placed in laboratory-prepared containers. Samples will be labeled following the nomenclature specified in the protocol document (Section 5.5) and placed in an ice chest maintained at a temperature of 4° Celsius for shipment. A chain-of-custody form will be filled out, and the ice chest shipped to Pace, Inc. laboratory in Huntington Beach, California for analysis. This laboratory has been audited by the U.S. Air Force and meets all quality assurance/quality control and certification requirements for the State of California.

### 3.4.2 Soil Gas Sampling

A total of nine initial soil gas samples will be collected in SUMMA™ canisters in accordance with the *Bioventing Field Sampling Plan* (Engineering-Science, Inc., 1992). The samples will be collected from the VW, and one each from the VMPs closest to and furthest from the VW at each facility. These soil gas samples will be used to predict potential air emissions, to determine the reduction in BTEX and total volatile hydrocarbons (TVH) during the 1-year test, and to detect any migration of these vapors from the source area.

Soil gas sample canisters will be placed in a small cooler and packed with foam pellets to prevent excessive movement during shipment. Samples will not be sent on ice to prevent condensation of hydrocarbons. A chain-of-custody form will be filled out, and the cooler will be shipped to the Air Toxics laboratory in Folsom, California for analysis.

### 3.5 Air Monitoring

The bioventing technique will minimize the loss of volatiles to the atmosphere by reducing air injection rates to the minimum required for oxygen supply for biodegradation. During air injection, the air will be monitored for volatile hydrocarbons at the soil surface and in the breathing zone to account for any volatilization that does occur and to ensure safe working conditions.

### 3.6 Blower System

A 1-horsepower regenerative blower capable of injecting air at a flow rate of 20 to 40 scfm at a pressure of 56 inches of water will be used to conduct the initial air permeability test at these sites. Air injection will be used to provide oxygen to soil bacteria and to minimize emissions of volatiles to the atmosphere. If initial testing indicates that less flow is required to supply oxygen throughout the test volume, the blower output will be reduced for the extended testing via an air bleed valve. Figure 3.5 is a schematic of a typical air injection system that will be used for pilot testing at this site. The maximum power requirement anticipated for this pilot test is either 230-volt, single-phase, 30-amp service or 120-volt 30 amp service. Additional details on power supply requirements are described in Section 5.0, Base Support Requirements.

### 3.7 In Situ Respiration Test

The objective of the *in situ* respiration test is to determine the rate at which soil bacteria degrade petroleum hydrocarbons. Respiration tests will be performed at the three VMPs at each site. Air will be injected into each VMP for a 20 to 24-hour

Figure 3.5

- LEGEND**
- ① INLET AIR FILTER
  - ② VACUUM GAUGE (in H<sub>2</sub>O)
  - ③ BLOWER - GAST/70 SCFM @ 20 INCHES H<sub>2</sub>O REGENERATIVE W/1HP DRIVE MOTOR
  - ④ MANUAL PRESSURE RELIEF (BLEED) VALVE - 1 1/2" GATE
  - ⑤ AUTOMATIC PRESSURE RELIEF VALVE
  - ⑥ PRESSURE GAUGE (in H<sub>2</sub>O)
  - ⑦ TEMPERATURE GAUGE (°F)
  - ⑧ POWER SWITCH
  - ⑨ BREAKER BOX (115V/SINGLE PHASE/30 AMP)
  - ⑩ AIR VELOCITY MEASURE PORT

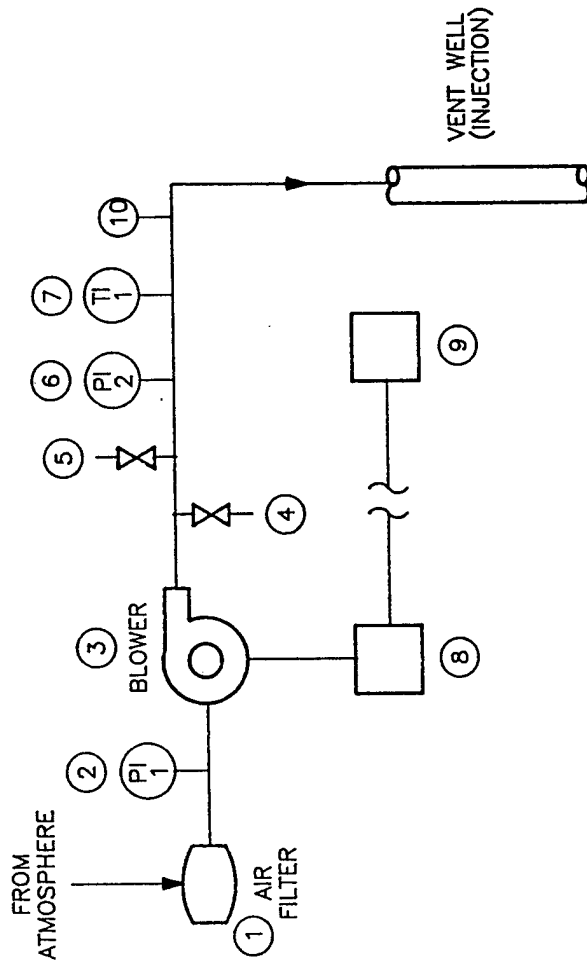

DRAWING IS NOT TO SCALE

PROPOSED BLOWER SYSTEM  
FOR AIR INJECTION

CAPE CANAVERAL, FLORIDA

ENGINEERING—SCIENCE, INC.  
Orlando, Florida

**ES**

air injection period, which will be used to oxygenate local contaminated soil. At the end of the air injection period, the air supply will be cut off, and oxygen and carbon dioxide levels will be monitored until the oxygen level falls below 5% or for five days whichever is earlier. The decline in oxygen and increase in carbon dioxide concentrations over time will be used to estimate rates of bacterial degradation of fuel residuals. Helium will also be injected at all three points at each site to ensure that the VMPs do not leak and to estimate oxygen diffusion rates in site soils.

### **3.8 Air Permeability Test**

The objective of the air permeability test is to determine the extent of the subsurface that can be oxygenated using the VWs. Air will be injected into the 4-inch diameter VW using the blower unit, and pressure response will be measured at each VMP with differential pressure gauges to determine the region influenced by the unit. Oxygen will also be monitored in the VMPs to ascertain that oxygen levels in the soil increase as the result of air injection. One air permeability test lasting 4 to 8 hours will be performed.

### **3.9 Installation of Extended Pilot Test Bioventing System**

Extended, 1-year bioventing pilot systems will also be installed at Facilities 1748, 44625D, and 44625E. At each site an electrical contractor will provide a power pole with either 230-volt, single-phase, 30-amp breaker box or 120-volt 30 amp breaker box. Two 120-volt utility receptacles will also be provided. The blower will be housed in a small, prefabricated shed to provide protection from the weather.

The system will be in operation for 1 year, and at 6 months and 12-months of operation, ES personnel will conduct *in situ* respiration tests to monitor the long-term performance of this bioventing system. Weekly system checks will be performed by either Patrick AFB or Cape Canaveral AFS personnel. If required, major maintenance of the blower unit may be performed by ES personnel. Detailed blower system information and a maintenance schedule will be included in the operation and maintenance (O&M) manual provided to the base. More detailed information regarding the test procedures can be found in the protocol document.

### **4.0 EXCEPTIONS TO PROTOCOL PROCEDURES**

The testing procedures that will be used to measure the air permeability of the soil and *in situ* respiration rates are described in Sections 4 and 5 of the protocol document. The only foreseen exception to field testing protocol procedures is the collection of the soil samples.

Soil borings for VMP installations will be advanced using a hand auger at these sites. A drilling contractor will not be needed for this procedure and the typical borehole diameter for each monitoring point will be approximately 4 inches, as illustrated in Figure 3.4.

## **5.0 BASE SUPPORT REQUIREMENTS**

### **5.1 Test Preparation**

The following base support is needed prior to the arrival of an excavation contractor and the ES test team:

- Assistance in obtaining a digging permit at Facilities 1748, 44625D, and 44625E at Cape Canaveral AFS.
- Base will approve location of power supply to be installed by the electrical contractor.
- Provide any paperwork required to obtain gate passes and security badges for approximately four (4) ES employees and two drilling contractors. Vehicle passes will be needed for three trucks.

During the initial 3-week pilot test, the following base support is needed:

- Twelve square feet of desk space and a telephone in a building located as close to the site as practical.
- A decontamination pad where the drilling contractor can clean equipment.
- Acceptance of responsibility by Patrick AFB and Cape Canaveral AFS for soil cuttings from VW and VMP borings, including any drum sampling to determine hazardous waste status.
- The use of a fax machine for transmitting 15 to 20 pages of test results.

During the 1-year extended pilot test at these facilities, the following support is needed:

- Check the blower system at the site once a week to ensure that it is operating and to record the air injection pressure. ES will provide a brief training session and an O&M checklist for this procedure.
- Notify Mr. Steve Archabal, ES-Orlando, (407) 841-8114; Mr. Dave Brown, ES-Syracuse, (315) 451-9560; or Mr. Marty Faile, AFCEE, (210) 536-4342, if the blower or motor stop operating.

- Arrange site access for an ES technician to conduct *in situ* respiration tests approximately 6 months and 1 year after the initial pilot test.

## 6.0 PROJECT SCHEDULE

The following schedule is contingent upon timely approval of this pilot test work plan:

Event	Date
Draft Test Work Plan to AFCEE/Patrick AFB/Cape Canaveral AFS	11/22/93
Begin Pilot Test	11/29/93
Complete Initial Pilot Test	12/23/93
Interim Results Report	February 94
Second Respiration Test	June 94
Final Respiration Test	December 94

After a period of 1 year, a decision will be made by AFCEE, Patrick AFB, and Cape Canaveral AFS to either remove the pilot system or to expand the system for full-scale remediation of the site soils.

## 7.0 POINTS OF CONTACT

Mr. Hugh Houghton  
45 CES/DEEV  
Patrick AFB, FL 32925  
(407) 494-4721

Lt. Colonel Ross Miller/Mr. Marty Faile  
AFCEE/EST  
Brooks AFB, Texas 78235-5000  
(210) 536-4331/(210) 536-4342

Dave Brown  
Engineering-Science, Inc.  
290 Elwood Davis Road  
Liverpool, New York  
(315) 451-9560

Steve Archabal  
Engineering-Science, Inc.  
255 S. Orange Avenue, Suite 1201  
Orlando, FL 32801  
(407) 841-8114

## 8.0 REFERENCES

- CH<sub>2</sub>M Hill, 1992. *Hazwrap, Martin Marietta Phase I Contamination Assessment*, Cape Canaveral Air Force Station, Orlando, Florida. April/July.
- Engineering-Science, Inc. 1993. *Project Management Plan for AFCEE Bioventing*, Appendix D, Field Sampling Plan. Denver, Colorado. January.
- Hinchee, R.E., Ong, S.K., Miller, R.N., Downey, D.C., Frandt, R. 1992. *Test Plan and Technical Protocol for a Field Treatability Test for Bioventing*. Columbus, Ohio. January.

**PART II**  
**DRAFT INTERIM PILOT TEST RESULTS REPORT FOR**  
**FACILITIES 1748, 44625D, AND 44625E**

**CAPE CANAVERAL AFS, FLORIDA**

**April 1994**

**Prepared for:**

**Air Force Center for Environmental Excellence**  
**Brooks AFB, Texas**

**and**

**45 CES/CEV**  
**Patrick AFB, Florida**

**Prepared by:**

**Engineering-Science, Inc.**  
**1700 Broadway, Suite 900**  
**Denver, Colorado 80290**

## CONTENTS

### PART II - DRAFT INTERIM PILOT TEST RESULTS REPORT FOR FACILITIES 1748, 44625D AND 44625E CAPE CANAVERAL AFS, FLORIDA

	<u>Page</u>
1.0 Facility 1748 .....	II-1
1.1 Pilot Test Design and Construction.....	II-1
1.1.1 Air Injection Vent Well Construction.....	II-2
1.1.2 Permanent Monitoring Points .....	II-2
1.1.3 Blower Unit Installation and Operation.....	II-6
1.2 Soil and Soil Gas Sampling Results .....	II-6
1.3 Exceptions to Test Protocol Document Procedures .....	II-9
1.4 Field QA/QC Results .....	II-9
1.5 Pilot Test Results.....	II-9
1.5.1 Initial Soil Gas Chemistry .....	II-9
1.5.2 Air Permeability .....	II-9
1.5.3 Oxygen Influence .....	II-9
1.5.4 <i>In Situ</i> Respiration Rates.....	II-13
1.5.5 Potential For Air Emissions.....	II-13
2.0 Facility 44625D, Cape Canaveral AFS .....	II-19
2.1 Pilot Test Design and Construction.....	II-19
2.1.1 Air Injection Vent Well Construction.....	II-19
2.1.2 Permanent Monitoring Points .....	II-19
2.1.3 Blower Unit Installation and Operation.....	II-23
2.2 Soil and Soil Gas Sampling Results .....	II-23
2.3 Exceptions to Test Protocol Document Procedures .....	II-26
2.4 Field QA/QC Results.....	II-26
2.5 Pilot Test Results.....	II-26
2.5.1 Initial Soil Gas Chemistry .....	II-26
2.5.2 Air Permeability .....	II-26
2.5.3 Oxygen Influence .....	II-26
2.5.4 <i>In Situ</i> Respiration Rates.....	II-30
2.5.5 Potential For Air Emissions.....	II-30
3.0 Facility 44625E, Cape Canaveral AFS.....	II-36
3.1 Pilot Test Design and Construction.....	II-36
3.1.1 Air Injection Vent Well Construction.....	II-36
3.1.2 Permanent Monitoring Points .....	II-36
3.1.3 Blower Unit Installation and Operation.....	II-40
3.2 Soil and Soil Gas Sampling Results .....	II-40
3.3 Exceptions to Test Protocol Document Procedures .....	II-43
3.4 Field QA/QC Results.....	II-43
3.5 Pilot Test Results.....	II-43
3.5.1 Initial Soil Gas Chemistry .....	II-43
3.5.2 Air Permeability .....	II-43
3.5.3 Oxygen Influence .....	II-47
3.5.4 <i>In Situ</i> Respiration Rates.....	II-47
3.5.5 Potential Air Emissions .....	II-47

CONTENTS (Continued)

4.0 Recommendations ..... II-53  
5.0 References ..... II-53

TABLES

No.      Title      Page

**Facility 1748, Cape Canaveral AFS**

1.1 Soil and Soil Gas Analytical Results..... II-10  
1.2 Initial Soil Gas Chemistry ..... II-11  
1.3 Pressure Response During Air Permeability Test..... II-12  
1.4 Influence of Air Injection at Vent Well on Monitoring  
Point Oxygen Levels ..... II-14  
1.5 Oxygen Utilization Rates ..... II-15

**Facility 44625D, Cape Canaveral AFS**

2.1 Soil and Soil Gas Analytical Results..... II-27  
2.2 Initial Soil Gas Chemistry ..... II-28  
2.3 Pressure Response During Air Permeability Test..... II-29  
2.4 Influence of Air Injection at Vent Well on Monitoring Point  
Oxygen Levels ..... II-31  
2.5 Oxygen Utilization Rates ..... II-35

**Facility 44625E, Cape Canaveral AFS**

3.1 Soil and Soil Gas Analytical Results..... II-44  
3.2 Initial Soil Gas Chemistry ..... II-45  
3.3 Pressure Response During Air Permeability Test..... II-46  
3.4 Influence of Air Injection at Vent Well on Monitoring Point  
Oxygen Levels ..... II-48  
3.5 Oxygen Utilization Rates ..... II-52

FIGURES

No.      Title      Page

**Facility 1748, Cape Canaveral AFS**

1.1 As-Built Vent Well, Monitoring Point, and Blower Locations .....II-3  
1.2 Hydrogeologic Cross Section .....II-4  
1.3 As-Built Vent Well Construction Detail.....II-5  
1.4 As-Built Monitoring Point Construction Detail .....II-7  
1.5 As-Built Blower System for Air Injection.....II-8  
1.6 Respiration Test - Oxygen and Helium Concentrations, MPA-5.5..... II-16  
1.7 Respiration Test - Oxygen and Helium Concentrations, MPB-5.5..... II-17  
1.8 Respiration Test - Oxygen and Helium Concentrations, MPC-5.5..... II-18

CONTENTS (Continued)

FIGURES (Continued)

<u>No.</u>	<u>Title</u>	<u>Page</u>
<b>Facility 44625D, Cape Canaveral AFS</b>		
2.1	As-Built Vent Well, Monitoring Point, and Blower Locations .....	II-20
2.2	Hydrogeologic Cross Section .....	II-21
2.3	As-Built Vent Well Construction Detail.....	II-22
2.4	As-Built Monitoring Point Construction Detail .....	II-24
2.5	As-Built Blower System for Air Injection.....	II-25
2.6	Respiration Test - Oxygen and Helium Concentrations, MPA-5.5.....	II-32
2.7	Respiration Test - Oxygen and Helium Concentrations, MPB-5.5 .....	II-33
2.8	Respiration Test - Oxygen and Helium Concentrations, MPC-5.5.....	II-34

**Facility 44625E, Cape Canaveral AFS**

3.1	As-Built Vent Well, Vapor Monitoring Point, and Blower Locations .....	II-37
3.2	Hydrogeologic Cross Section .....	II-38
3.3	As-Built Injection Vent Well Construction Detail .....	II-39
3.4	As-Built Monitoring Point Construction Detail .....	II-41
3.5	As-Built Blower System for Air Injection.....	II-42
3.6	Respiration Test - Oxygen and Helium Concentrations, MPA-5.5.....	II-49
3.7	Respiration Test - Oxygen and Helium Concentrations, MPB-5.5 .....	II-50
3.8	Respiration Test - Oxygen and Helium Concentrations, MPC-5.5.....	II-51

Appendix A - System Maintenance Instructions

Appendix B - Geologic Boring Logs, Test Data, and Calculations

Appendix C - Chain of Custody Forms

**PART II**  
**DRAFT INTERIM PILOT TEST RESULTS REPORT FOR**  
**FACILITIES 1748, 44625D, AND 44625E**  
**CAPE CANAVERAL AFS, FLORIDA**

An initial bioventing pilot test was performed by Engineering-Science, Inc. (ES) at each of the following sites at Cape Canaveral Air Force Station (AFS), Florida: Facility 1748, Facility 44625D, and Facility 44625E from December 30, 1993 through February 8, 1994. The three primary objectives of the pilot tests are:

- To assess the potential for supplying oxygen throughout the contaminated soil interval;
- To determine the rate at which indigenous microorganisms will degrade fuel when supplied with oxygen-rich soil gas, and
- To evaluate the potential for sustaining these rates of biodegradation until fuel contamination is remediated to concentrations below regulatory standards.

The purpose of this report is to describe the results of the initial pilot tests and to make specific recommendations for extended testing to determine the long-term impact of bioventing to remediate the site contaminants. Descriptions of the history, geology, and site contaminants of each site are found in Part I of this report, Bioventing Pilot Test Work Plan.

## **1.0 FACILITY 1748**

### **1.1 Pilot Test Design and Construction**

The following sections describe the final design and installation of the bioventing system at Facility 1748, the base cafeteria. A vertical air injection venting well (VW) was installed on December 23, 1993, by Engineering-Science, Inc. (ES) of Orlando, Florida and a subcontractor, Groundwater Protection, Inc. (Drilling Division) of Orlando, Florida. Four permanent pressure/vapor monitoring points (MPs) were installed on December 30, 1993. The VW construction, MP installations, and soil sampling were directed by Mr. Steve Archabal, the ES site manager. The following sections describe in more detail the final design, installation, and testing of the bioventing system at this site.

One VW, four permanent MPs, and a blower unit in a weatherproof enclosure were installed at Facility 1748. A single-depth MP construction was used at the site, the only exception being the background MP location. A monitoring depth screen interval of 5.0 to 5.5 feet below land surface (bls) was installed at all single-depth MP

locations, due to the shallow water table at approximately 6.5 feet bls at this site. At the background MP location, a multi-depth construction was used, with the screened intervals installed at 2.5 to 3.0 and 5.0-5.5 feet bls. Figure 1.1 depicts the test area with the locations of the MPs, VW, and blower at Facility 1748. Figure 1.2 shows a hydrogeologic cross section oriented in a north-south direction.

### **1.1.1 Air Injection Venting Well Construction**

The VW was installed within the area of the former underground 4,000-gallon diesel fuel tank, as shown in Figure 1.1. The VW was constructed in visibly contaminated, oxygen-depleted soils. Soils encountered during the VW construction were darkly stained and emitted hydrocarbon odors.

The installation of the VW was in accordance with typical Air Force Center for Environmental Excellence (AFCEE) work plan protocols (Hinchee et al., 1992). On the date of the VW installation, groundwater level at the Facility 1748 was approximately 6.5 feet bls.

The VW was constructed using 4-inch-diameter, Schedule 40 polyvinyl chloride (PVC) casing with 5 feet of 0.03-inch slotted PVC screen installed from 3 to 8 feet bls. The annular space between the well casing and borehole was filled with 6/20 graded silica sand to approximately 1 foot above the well screen. A 1-foot layer of bentonite pellets was placed above the sand and hydrated in place. A 1-foot cement grout seal was placed over the bentonite to ground surface. The top of the VW was completed with a flush-mount steel well manhole set in a 2x2-foot concrete pad. Figure 1.3 shows the as-built construction details for the VW. The geologic soil boring log for the VW installation is presented in Appendix B.

### **1.1.2 Permanent Monitoring Points**

Four permanent, single-depth MPs were installed at Facility 1748 on December 30, 1993. MPs CA2-MPA, CA2-MPB, and CA2-MPC were installed at respective distances of 10, 20, and 30 feet from the VW location. A permanent background MP, MPBG, was installed 72 feet south and 19 feet due east of the VW location (see Figure 1.1). All permanent MP boreholes were advanced using a decontaminated stainless steel hand auger. MPA, MPB, and MPC were screened at 5.0 to 5.5 feet bls, and the multi-depth MPBG was screened at 2.5 to 3.0 and 5.0 to 5.5 feet bls.

All four permanent MPs were constructed using 0.5-inch-diameter PVC screens and casing installed in 4-inch-diameter boreholes. Each MP was constructed using a 6-inch section of 0.02-inch-slotted, Schedule 40 PVC screen and Schedule 80 PVC casing. Each screened interval was surrounded by a filter pack of 6/20 graded coarse silica sand.

Thermocouples were also installed at the screened intervals of MPA, MPC, and MPBG. Bentonite pellets, hydrated in place, were used to seal the annulus around each MP riser above the sand pack and between the screened intervals at the background MP location. Then a 3-foot-thick grout seal was placed over the bentonite to ground surface. The top of each MP PVC riser was completed at ground surface with a brass ball valve and a 0.25-inch brass hose barb. Each MP was completed at the surface with an 8-inch flush-mounted steel manhole set in a concrete 2x2-foot pad. The lid to

Figure 1.1

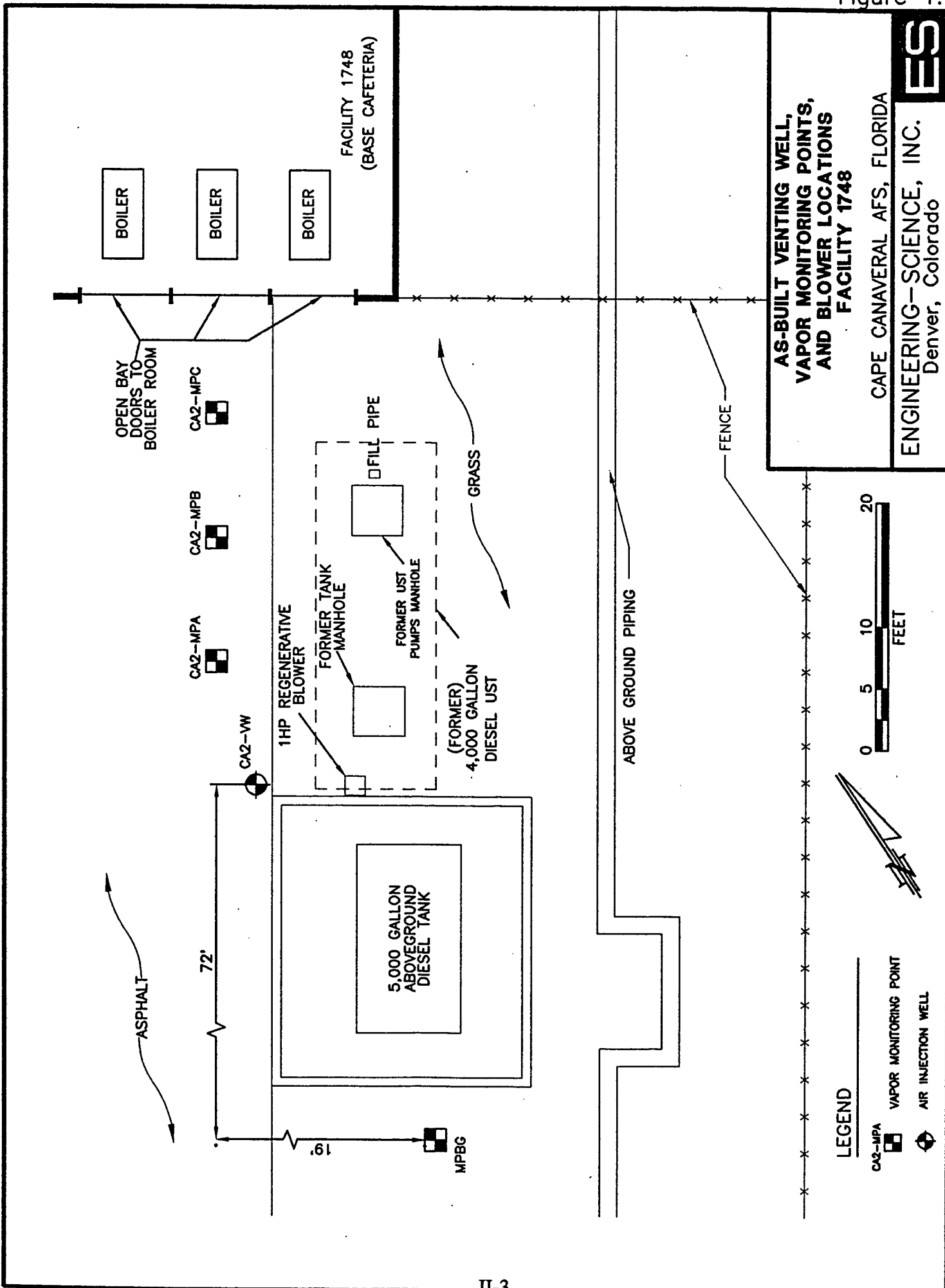

**AS-BUILT VENTING WELL,  
VAPOR MONITORING POINTS,  
AND BLOWER LOCATIONS  
FACILITY 1748**

CAPE CANAVERAL AFS, FLORIDA

**ENGINEERING-SCIENCE, INC.**  
Denver, Colorado



- LEGEND**
- CA2-MPA [Symbol] VAPOR MONITORING POINT
  - [Symbol] AIR INJECTION WELL

Figure 1.2

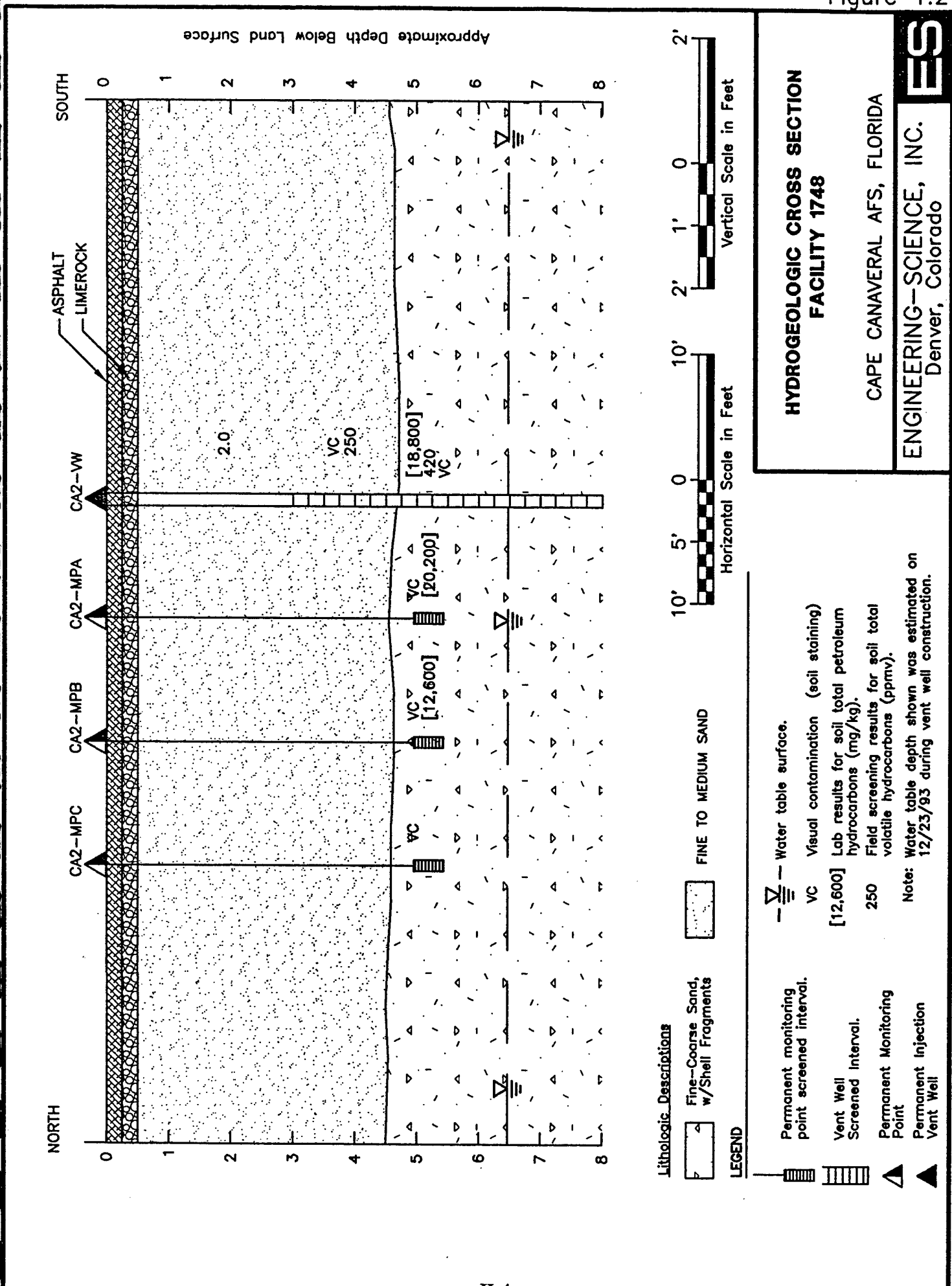

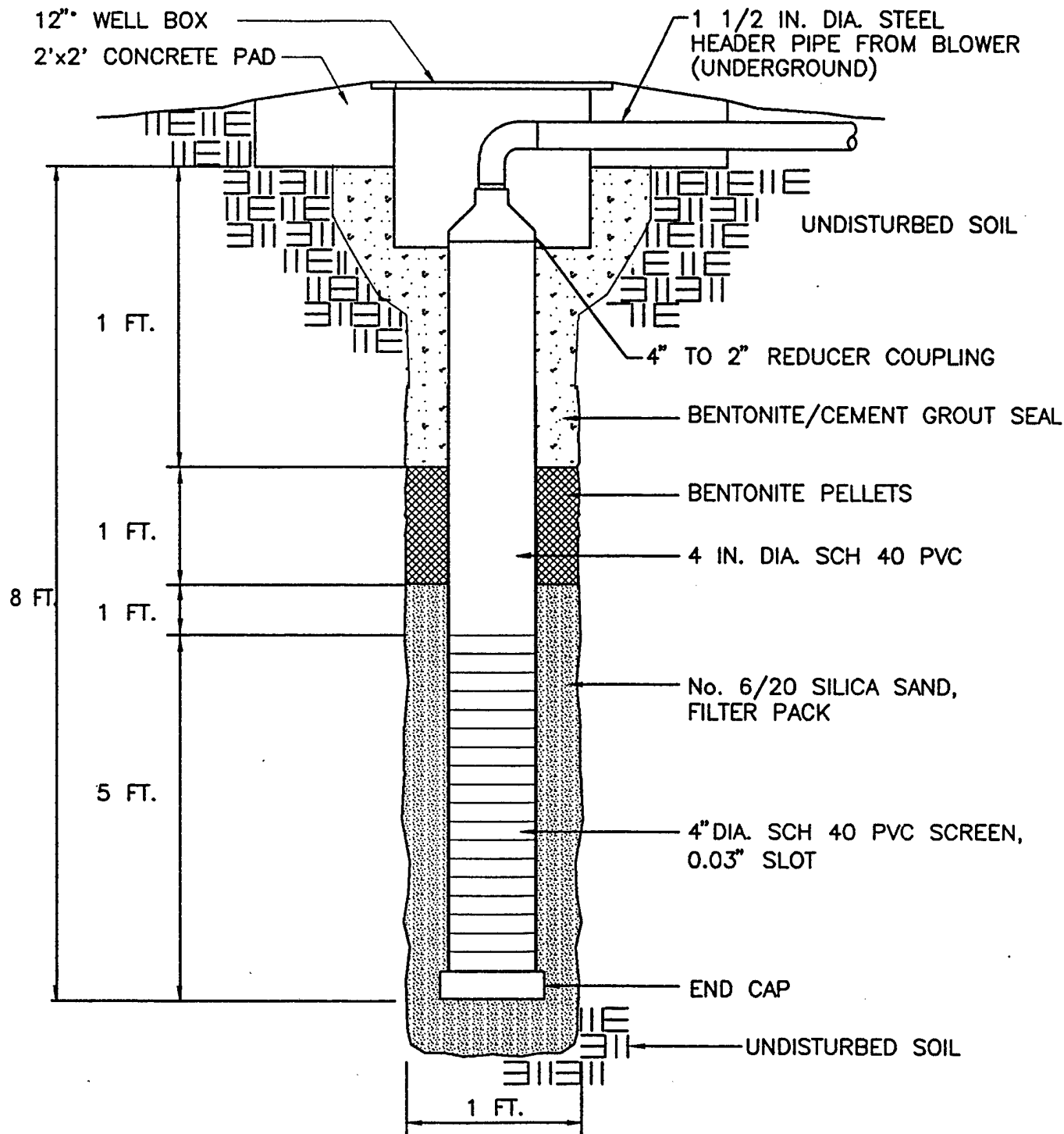

NOT TO SCALE

**AS-BUILT INJECTION VENT  
WELL CONSTRUCTION DETAIL  
FACILITY 1748**

CAPE CANAVERAL AFS, FLORIDA

ENGINEERING-SCIENCE, INC.  
Denver, Colorado



the manhole was set approximately 1 inch above ground surface, and the concrete base was sloped toward the edges to promote drainage of surface water away from the MP. Figure 1.4 shows a typical permanent MP construction detail.

### **1.1.3 Blower Unit Installation and Operation**

A 1-horsepower Gast® regenerative blower unit was installed at Facility 1748 for the initial and extended pilot tests. The Gast® blower was installed in a weatherproof enclosure and electrically wired for 115-volt, 30-amp power.

Air is supplied by the blower through a 1.5-inch-diameter above/below ground steel header pipe that is attached to the VW. Figure 1.5 shows the configuration, instrumentation, and specifications for the blower and air injection system.

Prior to departing from the site, ES personnel provided operations and maintenance (O&M) instructions to AFS personnel. A copy of the O&M instructions is provided in Appendix A.

## **1.2 SOIL AND SOIL GAS SAMPLING RESULTS**

Soils at Facility 1748 consist of loose, fine- to coarse-grained sand, with shell fragments. This soil profile was consistent across the site at each boring location from ground surface to below the water table surface, which typically averages 6 to 8 feet bls. The fine to coarse sands range in color from light gray to gray, with the exception being a layer of brown sand from 3.5 to 4.5 feet bls.

Soil hydrocarbon contamination at this site appeared to be confined mainly within the boundaries of the former 4,000-gallon diesel underground storage tank (UST) location. Contaminated soils were identified based on visual appearance, odor, and volatile organic compound (VOC) field screening results. Heavily contaminated soils were encountered during the VW installation and during all MP installations. Soils were not contaminated at the background MP location (MPBG). Contaminated soils exhibited strong hydrocarbon odors and were visibly stained. The highest concentrations of total VOCs occurred at depths below 4 feet. Soil gas VOC readings ranged from 140 to >20,000 parts per million, volume per volume (ppmv) of total hydrocarbons at the MPs and VW locations.

Soil samples for laboratory analysis were collected from the stainless steel hand-auger bucket during the installation of the permanent MPs. Soil samples were collected from 5.5 feet bls at MPA, MPB, and the VW boreholes. Soil samples were screened for VOCs using a GasTech/Trace-techtor® hydrocarbon analyzer to determine the presence of contamination and to select soil samples for laboratory analysis.

Soil samples were shipped via Federal Express® to Pace, Inc. in Huntington Beach, California for chemical and physical analyses. Each of the soil samples was analyzed for the following parameters: total recoverable petroleum hydrocarbons (TRPH); benzene, toluene, ethylbenzene, and xylenes (BTEX); iron; alkalinity; total Kjeldahl nitrogen (TKN); pH; phosphates; percent moisture; and grain size distribution. Soil gas samples were shipped via Federal Express® to Air Toxics, Inc. in Folsom,

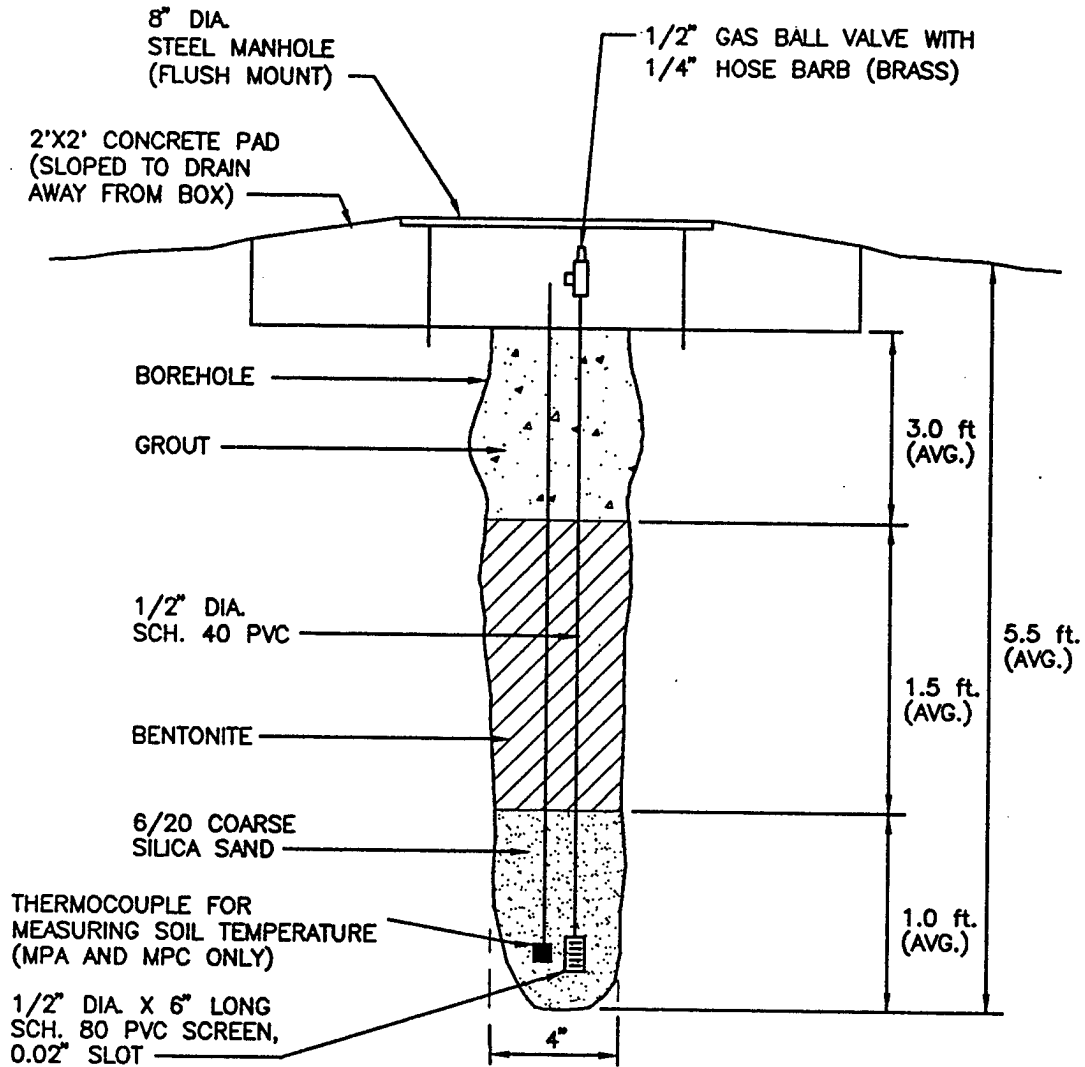

MONITORING POINT CONSTRUCTION SPECIFICATIONS

Monitoring Point No.	Borehole Depth (FT)	Screen Interval (Feet BLS)
MPA-5.5	5.5	5.0-5.5
MPB-5.5	5.5	5.0-5.5
MPC-5.5	5.5	5.0-5.5

BACKGROUND MONITORING POINT

MP-3.0		2.5-3.0
MP-5.5	5.5	5.0-5.5

NOTE:

AS-BUILT BACKGROUND MP WAS CONSTRUCTED THE SAME AS MP'S AT FACILITY 44625D/E.

DRAWING IS NOT TO SCALE

**AS-BUILT PERMANENT  
MONITORING POINT CONSTRUCTION DETAIL  
FACILITY 1748**

CAPE CANAVERAL AFS, FLORIDA

ENGINEERING-SCIENCE, INC.  
Denver, Colorado

**ES**

Figure 1.5

- LEGEND**
- ① INLET AIR FILTER
  - ② VACUUM GAUGE (in H<sub>2</sub>O)
  - ③ BLOWER - GAST/70 SCFM @ 20 INCHES H<sub>2</sub>O REGENERATIVE W/1HP DRIVE MOTOR
  - ④ AUTOMATIC PRESSURE RELIEF VALVE
  - ⑤ MANUAL PRESSURE RELIEF (BLEED) VALVE - 1 1/2" GATE
  - ⑥ IN-LINE 1 1/2" GATE VALVE
  - ⑦ PRESSURE GAUGE (in H<sub>2</sub>O)
  - ⑧ TEMPERATURE GAUGE (°F)
  - ⑨ POWER SWITCH/TIMEP BOX
  - ⑩ BREAKER BOX (115V/SINGLE PHASE/30 AMP)
  - ⑪ AIR VELOCITY MEASURE PORT

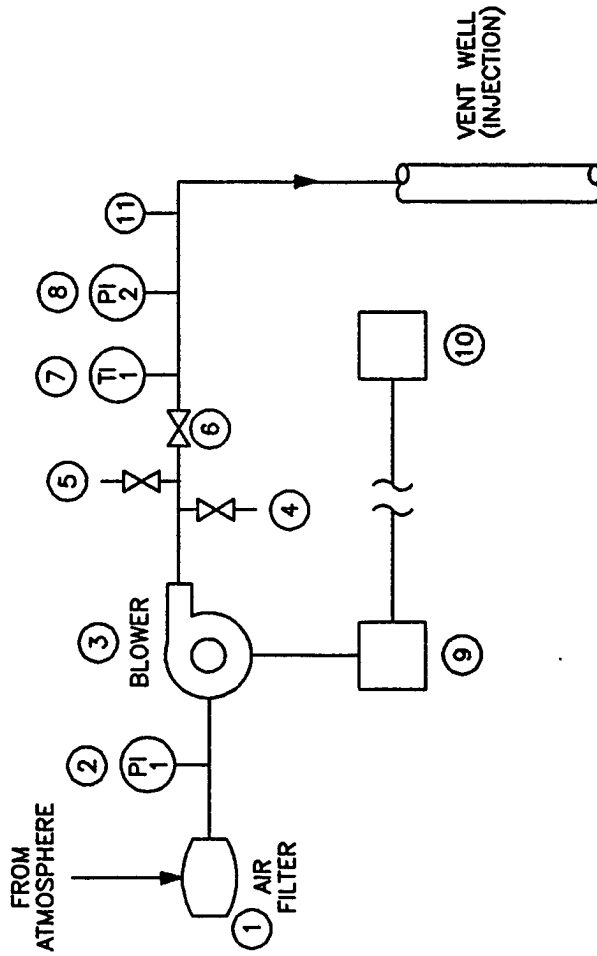

DRAWING IS NOT TO SCALE

**AS-BUILT BLOWER SYSTEM  
FOR AIR INJECTION**

CAPE CANAVERAL AFS., FLORIDA

**ENGINEERING-SCIENCE, INC.**  
Denver, Colorado



California for total volatile hydrocarbon (TVH) and BTEX analyses. The results of these analyses are presented in Table 1.1, and the chain-of-custody form is presented in Appendix C.

### **1.3 EXCEPTIONS TO TEST PROTOCOL DOCUMENT PROCEDURES**

Test procedures described in the protocol document (Hinchee et al., 1992) were used to complete the treatability pilot tests at this site. No exceptions to the standard protocol document or the Bioventing Pilot Test Work Plan (Part I) were necessary at Facility 1748.

### **1.4 FIELD QA/QC RESULTS**

Field quality assurance/quality control (QA/QC) samples were not collected or required at this site.

### **1.5 PILOT TEST RESULTS**

#### **1.5.1 Initial Soil Gas Chemistry**

Prior to initiating any air injection, all MPs were purged until oxygen levels had stabilized, and initial oxygen, carbon dioxide, and TVH concentrations were sampled using portable gas analyzers, as described in the technical protocol document (Hinchee et al., 1992). In soils surrounding each MP screened interval and at the VW, microorganisms had completely depleted soil gas oxygen supplies, indicating significant biological activity and soil contamination. The uniformity of zero oxygen levels at this site is primarily the result of the vertical and horizontal uniformity of soil bioactivity and contamination. Table 1.2 describes initial soil gas chemistry at this site. The background MP located at this site showed near-atmospheric levels of oxygen and carbon dioxide, indicating that uncontaminated soils at the same depth do not exert significant oxygen demand due to natural organic biodegradation or abiotic reactions.

#### **1.5.2 Air Permeability**

An air permeability test was conducted according to protocol document procedures. Air was injected into the VW for 4 hours at a rate of approximately 58 standard cubic feet per minute (scfm) and an average pressure of 25 inches of water. Steady-state pressure levels were achieved in all MPs after only 5 minutes of air injection. Table 1.3 provides the steady-state pressures at each MP. Due to this rapid pressure response, the steady-state method of determining air permeability was selected. A soil gas permeability value of 60 darcys, typical for sandy soils, was calculated for this site. A radius of pressure influence of over 30 feet was observed.

#### **1.5.3 Oxygen Influence**

The radius of oxygen increase in the subsurface resulting from air injection into the VW during pilot testing is an important design parameter for full-scale bioventing systems. Optimization of full-scale and multiple vent well systems requires pilot testing to determine the volume of soil that can be oxygenated at a given flow rate and vent well screen configuration.

**TABLE 1.1**  
**SOIL AND SOIL GAS LABORATORY ANALYTICAL RESULTS**  
**FACILITY 1748**  
**CAPE CANAVERAL AFS, FLORIDA**

Analyte (Units) <sup>a/</sup>	Sample Location-Depth (feet below land surface)		
	<u>VW 3-6.5</u>	<u>MPA-5.5</u>	<u>MPC-5.5</u>
<u>Soil Gas Hydrocarbons</u>			
TVH (ppmv)	510	740	1,000
Benzene (ppmv)	0.26	0.91	3.3
Toluene (ppmv)	ND <sup>b/</sup>	ND	ND
Ethylbenzene (ppmv)	1.2	3.6	5.5
Xylenes (ppmv)	2.6	3.9	3.4
	<u>VW-5.5</u>	<u>MPA-5.5</u>	<u>MPB-5.5</u>
<u>Soil Hydrocarbons</u>			
TRPH (mg/kg)	18,800	20,200	12,600
Benzene (mg/kg)	ND	ND	ND
Toluene (mg/kg)	ND	ND	ND
Ethylbenzene (mg/kg)	0.51	5.1	ND
Xylenes (mg/kg)	3.7	8.3	5.1
<u>Soil Inorganics</u>			
Iron (mg/kg)	916	712	1,080
Alkalinity (mg/kg as CaCO <sub>3</sub> )	360	282	543
pH (units)	7.8	8.8	8.8
TKN (mg/kg)	66	100	170
Phosphates (mg/kg)	190	230	510
<u>Soil Physical Parameters</u>			
Soil Temperature (°F) <sup>d/</sup>	NS <sup>c/</sup>	72.8	NS
Moisture (% wt.)	9.1	11.8	6.7
Gravel (%)	0.2	0.1	0.0
Sand (%)	96.6	96.9	96.2
Silt (%)	0.6	0.4	1.1
Clay (%)	2.6	2.6	2.6

- a/ TRPH = total recoverable petroleum hydrocarbons; TPH = total petroleum hydrocarbons; mg/kg = milligrams per kilogram, ppmv = parts per million, volume per volume; CaCO<sub>3</sub> = calcium carbonate; TKN = total Kjeldahl nitrogen.
- b/ ND = not detected.
- c/ NS = not sampled.
- d/ Soil temperature at MPC-5.5 was 74.6°F.

**TABLE 1.2**  
**INITIAL SOIL GAS CHEMISTRY**  
**FACILITY 1748**  
**CAPE CANAVERAL AFS, FLORIDA**

Sample Location	Depth (ft)	O <sub>2</sub> (%)	CO <sub>2</sub> (%)	Field TVH (ppmv) <sup>a/</sup>	Lab TVH (ppmv) <sup>b/</sup>	Lab TRPH (mg/kg) <sup>c/</sup>
MPA	5.5	0.0	16.9	360	740	20,200
MPB	5.5	0.0	17.5	420	NC <sup>c/</sup>	12,600
MPC	5.5	0.0	18.0	500	1,000	NS <sup>c/</sup>
VW	3-6.5	0.0	16.5	300	510	18,800
MPBG	3.0	20.5	0.5	0.0	NS	NS
	5.5	20.3	0.7	0.0	NS	NS

- a/ Gastech/Trace-techtor<sup>®</sup> field screening results.  
b/ Laboratory results.  
c/ NS = not sampled.

**TABLE 1.3**  
**MAXIMUM PRESSURE RESPONSE**  
**AIR PERMEABILITY TEST**  
**FACILITY 1748**  
**CAPE CANAVERAL AFS, FLORIDA**

	<u>Distance from injection well (VW) (feet)</u>		
	10 (MPA)	20 (MPB)	30 (MPC)
Depth (feet bls)	5.5	5.5	5.5
Time (min)	10.0	10.0	10.0
Max Press (inches H <sub>2</sub> O)	2.3	0.97	0.44

Table 1.4 presents the change in soil gas oxygen levels that occurred during 4 hours of air injection. This period of air injection at approximately 58 scfm produced changes in soil gas oxygen levels throughout the 30-foot radius of the pilot testing area. Based on this rapid increase in oxygen levels, it is anticipated that the radius of influence for a long-term bioventing system at this site will exceed 30 feet. During the startup of the extended pilot test system, the air injection rate will be reduced to the minimum flow required to provide oxygen within a radius of 30 feet from the VW. Based on similar systems constructed in sandy soils, it is anticipated that an air injection rate of approximately 20 scfm will be sufficient for extended testing.

#### **1.5.4 *In Situ* Respiration Rates**

The *in situ* respiration test was performed by injecting a mixture of air (oxygen) and approximately 4 to 5 percent helium (inert tracer gas) into the three MP screened intervals (MPA-5.5, MPB-5.5, and MPC-5.5) for a 20-hour period. Oxygen loss and other changes in soil gas composition over time were then measured at each MP. Oxygen, TVH, carbon dioxide, and helium were measured for a period of approximately 16 hours following air injection. The measured oxygen losses were then used to calculate biological oxygen utilization rates. The results of *in situ* respiration testing for MPA, MPB, and MPC are presented in Figures 1.6 through 1.8. Table 1.5 provides a summary of the oxygen utilization rates.

Because helium is a conservative, inert gas, the change in helium concentrations over time can be useful in determining the effectiveness of the bentonite seals above MP screened intervals. Figures 1.6 through 1.8 compare oxygen utilization and helium retention. Because helium will diffuse approximately three times faster than oxygen due to oxygen's greater molecular weight, the measured oxygen loss at these MPs is the result of bacterial respiration and not due to oxygen diffusion or oxygen loss from leaks in the MPs.

Oxygen loss occurred at moderate rates, ranging from 0.0024 percent per minute (%/min) at MPB-5.5 to 0.0027 %/min at MPA-5.5. Based on test results at MPA-5.5, an estimated 640 milligrams (mg) of fuel per kilogram (kg) of soil can be degraded each year at this site. This estimate is based on an air-filled porosity of approximately 0.12 liter per kg of soil, and a conservative ratio of 3.5 mg of oxygen consumed for every 1 mg of fuel biodegraded. This estimate is conservative because moisture content at MPA-5.5 was greater than at the other MP locations, resulting in a lower air-filled porosity and rate of fuel biodegradation. Additional information on the calculations for fuel biodegradation can be found in Section 5 of the protocol document. Actual rates will vary, and could be reduced during the rainy season due to higher soil moisture and reduced air-filled porosity, or increased during warm summer months.

#### **1.5.5 Potential For Air Emissions**

The long-term potential for air emissions from full-scale bioventing operations at this site is considered low because the site is partially paved and of the low initial BTEX levels (<10 ppmv) in the site soil gas and the low injection rate proposed for extended testing. Health and safety monitoring was conducted during the 4-hour air permeability test using a GasTech® total hydrocarbon analyzer sensitive to 1-ppmv

**TABLE 1.4**  
**INFLUENCE OF AIR INJECTION AT VENT WELL**  
**ON MONITORING POINT OXYGEN LEVELS**  
**FACILITY 1748**  
**CAPE CANAVERAL AFS, FLORIDA**

MP	Distance From VW (ft)	Depth (ft bls)	Initial O <sub>2</sub> (%)	<u>Final O<sub>2</sub> (%)</u> Permeability Test <sup>a/</sup>
A	10	5.5	0.0	NS <sup>b/</sup>
B	20	5.5	0.0	NS
C	30	5.5	0.0	13.7

a/ Reading taken at end of 4 hours of air injection.

b/ NS = Not sampled.

**TABLE 1.5**  
**OXYGEN UTILIZATION RATES**  
**FACILITY 1748**  
**CAPE CANAVERAL AFS, FLORIDA**

Location	O <sub>2</sub> Loss <sup>a/</sup> (%)	Test <sup>b/</sup> Duration (min)	O <sub>2</sub> Utilization <sup>c/</sup> Rate (%/min)
MPA-5.5	17.9	6,960	0.0027
MPB-5.5	16.4	6,960	0.0024
MPC-5.5	18.7	6,960	0.0027

a/ Actual measured oxygen loss.

b/ Elapsed time from beginning of test to time when minimum oxygen concentration was measured.

c/ Values based on best-fit lines (Figures 1.6 through 1.8).

Respiration Test  
 Oxygen and Helium Concentrations  
 Facility 1748 (Base Cafeteria), MPA-5.5  
 Cape Canaveral AFS, FL

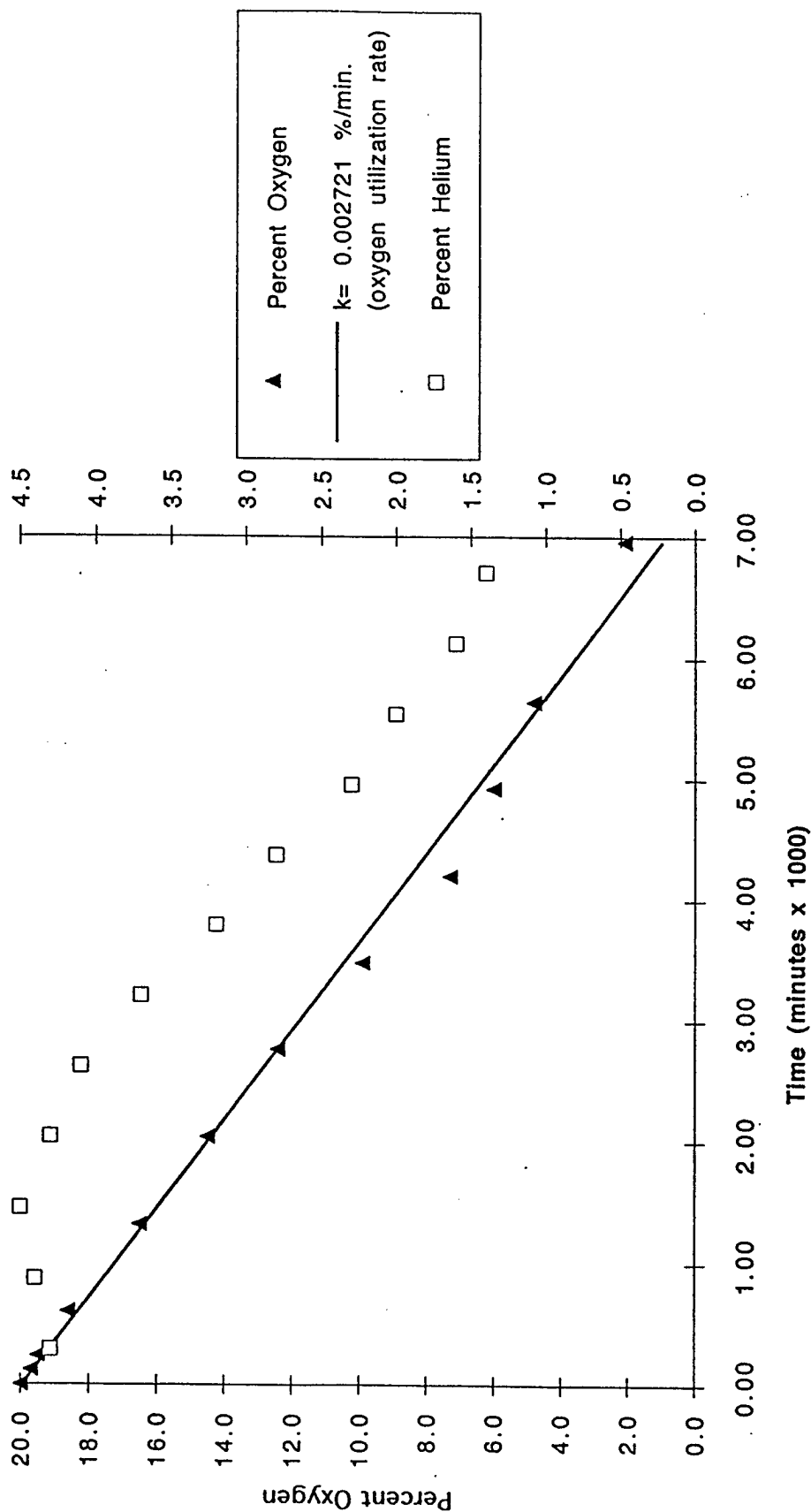

Figure 1.6

Respiration Test  
Oxygen and Helium Concentrations  
Facility 1748 (Base Cafeteria), MPB-5.5  
Cape Canaveral AFS, FL

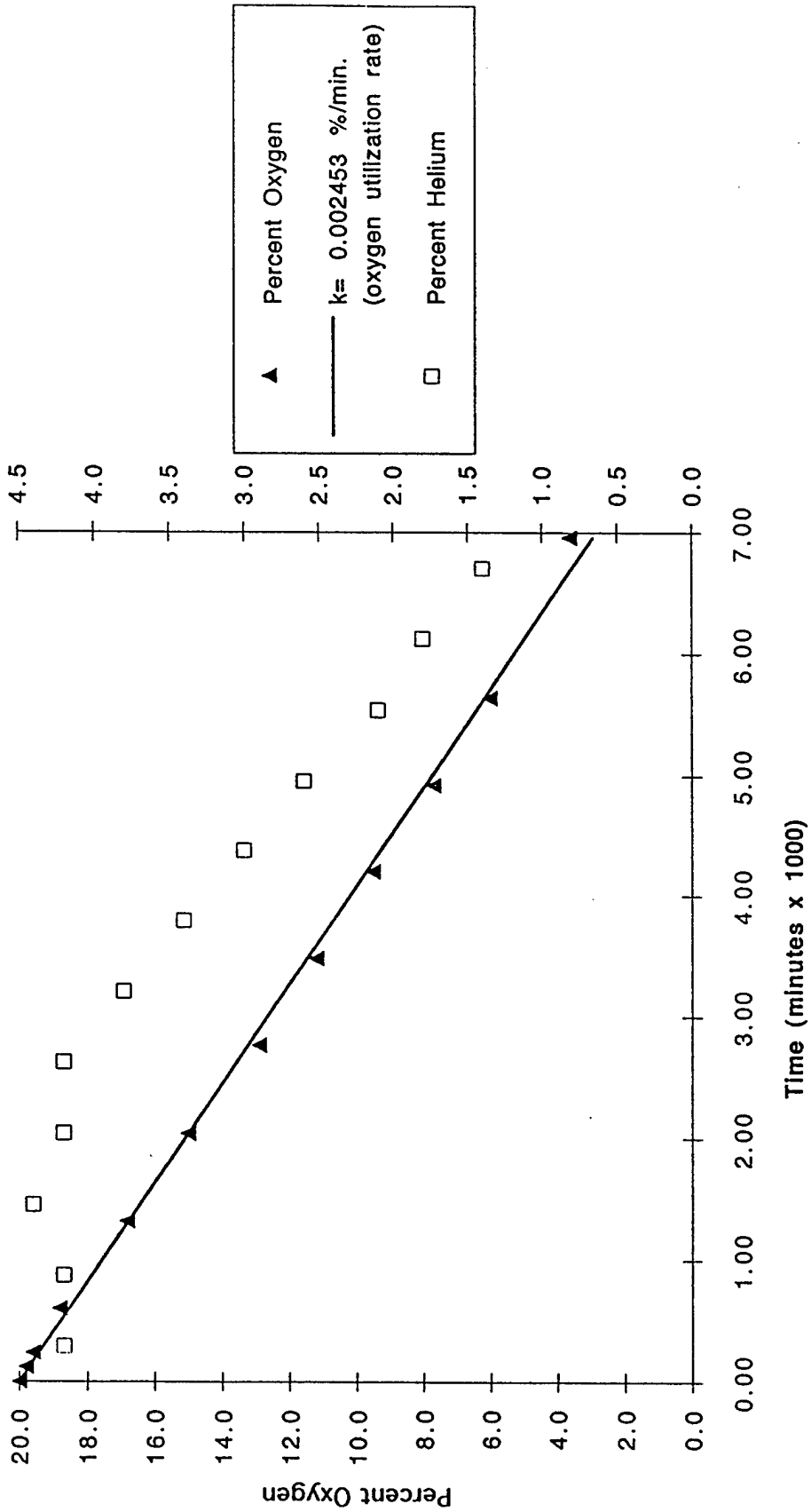

Figure 1.7

Respiration Test  
 Oxygen and Helium Concentrations  
 Facility 1748 (Base Cafeteria), MPC-5.5  
 Cape Canaveral AFS, FL

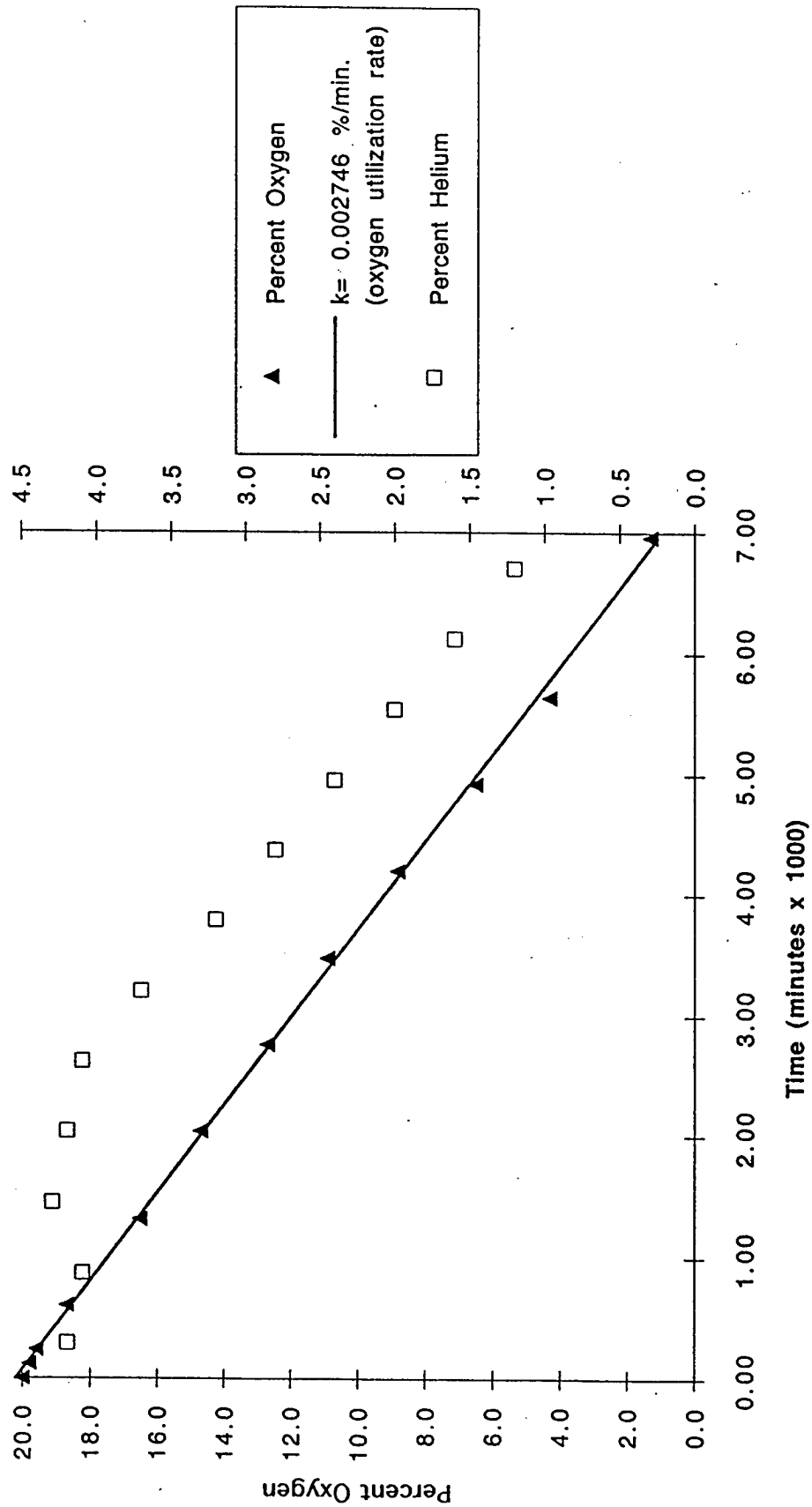

Figure 1.8

increases in volatile hydrocarbons. No sustained emissions in excess of 1 ppmv were detected in the breathing zone. Because the potential for air emissions is highest during the initial few hours of air injection, the long-term emission potential is considered low.

## **2.0 FACILITY 44625D**

### **2.1 Pilot Test Design and Construction**

The following sections describe the final design and installation of the bioventing system at Facility 44625D, the generator shop drum storage area. One air injection VW was installed on December 23, 1993, by ES and a subcontractor, Groundwater Protection, Inc. (Drilling Division), both of Orlando, Florida. Three permanent pressure/vapor MPs were installed on December 30, 1993. The VW construction, MP installations, and soil sampling were directed by Mr. Steve Archabal, the ES site manager. The following sections describe in more detail the final design, installation, and testing of the bioventing system at this site.

One VW, three permanent MPs, and a blower unit in a weatherproof enclosure were installed at Facility 44625D. The locations of the MPs and VW followed the original work plan (Part I of this report). A multi-depth MP construction was used at the site. Monitoring depth screen intervals of 2.5 to 3.0 and 5.0 to 5.5 feet bls were installed at this site. Figure 2.1 depicts the test area with the locations of the MPs, VW, and blower at Facility 44625D. Figure 2.2 shows a hydrogeologic cross section oriented in an east-west direction.

#### **2.1.1 Air Injection Venting Well Construction**

The VW was installed near the drum storage area of the generator maintenance area, as shown in Figure 2.1. The VW was constructed in visibly contaminated, oxygen-depleted soils. Soils encountered during the VW construction were darkly stained and emitted strong hydrocarbon odors.

The installation of the VW was in accordance with typical AFCEE work plan protocol (Hinchee et al., 1992). On the date of the VW installation, water level at Facility 44625D was approximately 6.5 feet bls.

The VW was constructed using 4-inch-diameter, Schedule 40 PVC casing with 5 feet of 0.03-inch slotted PVC screen installed from 3 to 8 feet bls. The annular space between the well casing and borehole was filled with 6/20 graded silica sand to approximately 1 foot above the well screen. A 1-foot layer of bentonite pellets were placed above the sand and hydrated in place. A 1-foot cement grout seal was placed over the bentonite to ground surface. The top of each VW was completed with a flush-mount steel well manhole set in a 2x2-foot concrete pad. Figure 2.3 shows the as-built construction details for the VW. The geologic soil boring log for the VW installations is provided in Appendix B.

#### **2.1.2 Permanent Monitoring Points**

Three permanent, multi-depth MPs were installed at Facility 44625D on December 30, 1993. MPs CA3-MPA, CA3-MPB, and CA3-MPC were installed at respective distances of 10, 20, and 30 feet from the VW location. A permanent background MP,

Figure 2.1

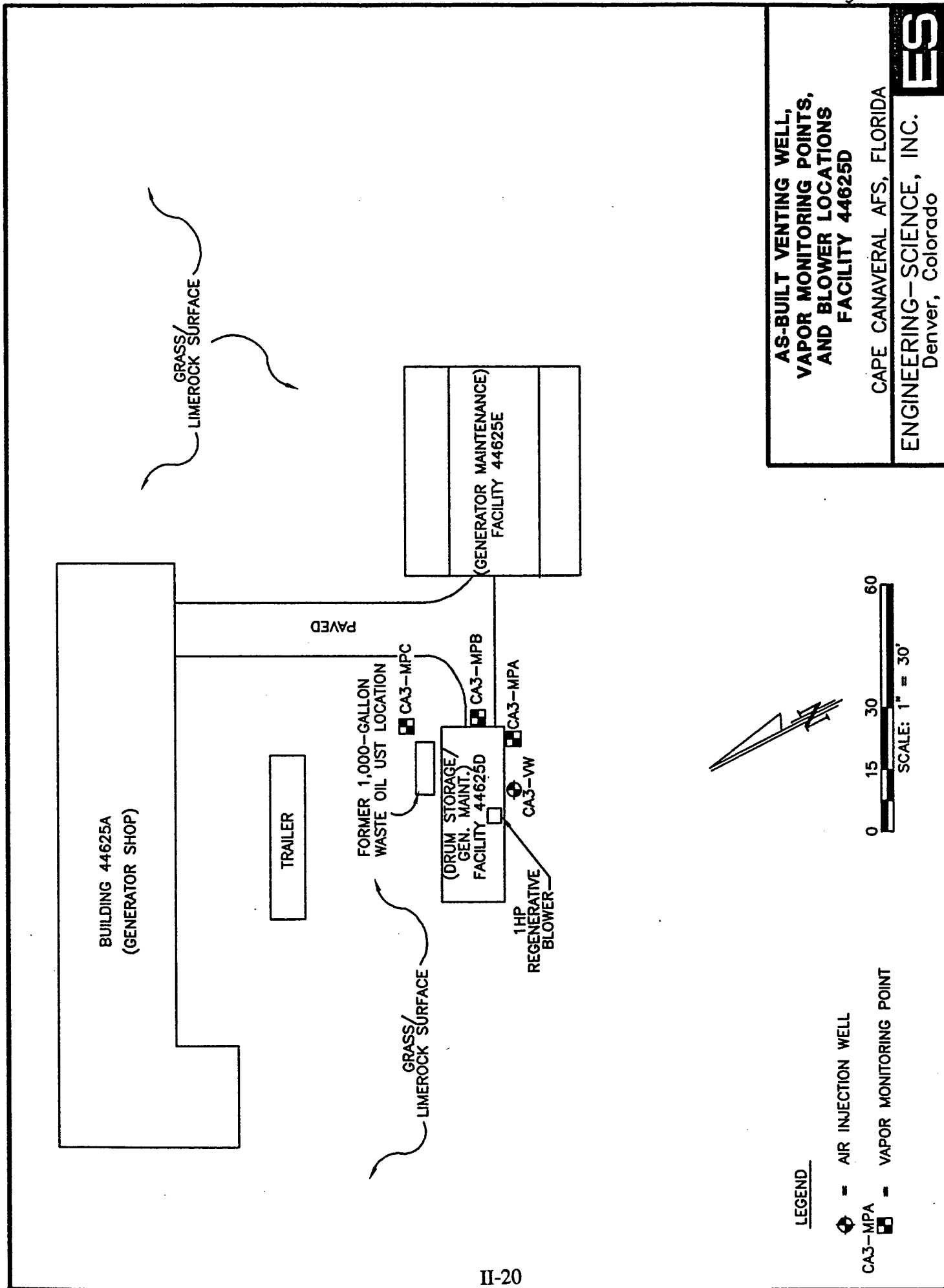

**AS-BUILT VENTING WELL,  
VAPOR MONITORING POINTS,  
AND BLOWER LOCATIONS  
FACILITY 44625D**

CAPE CANAVERAL AFS, FLORIDA  
**ENGINEERING-SCIENCE, INC.**  
Denver, Colorado



LEGEND

- ⊕ - AIR INJECTION WELL
- CA3-MPA - VAPOR MONITORING POINT

Figure 2.2

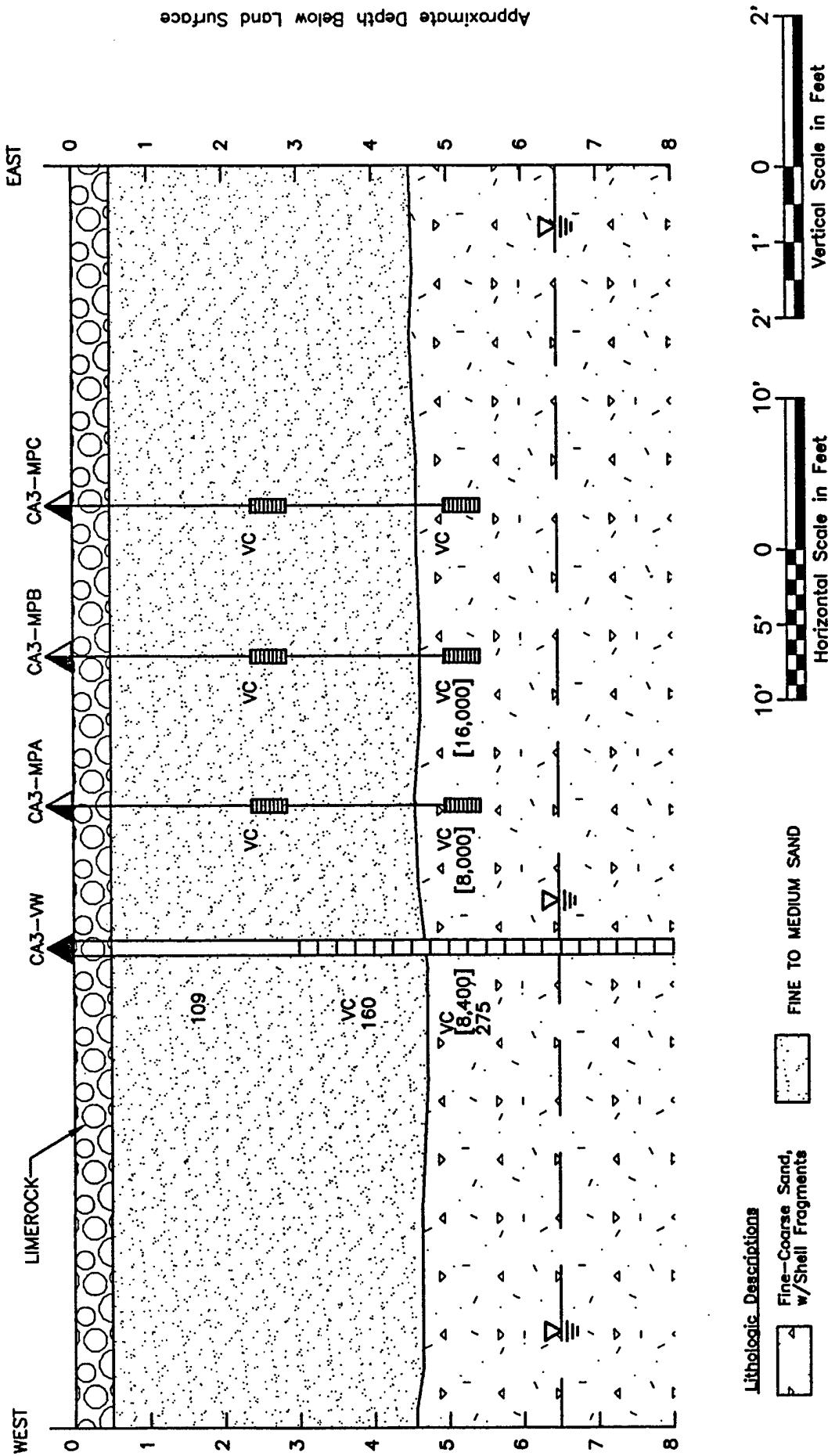

**HYDROGEOLOGIC CROSS SECTION  
FACILITY 44625D**

CAPE CANAVERAL AFS, FLORIDA

ENGINEERING-SCIENCE, INC.  
Denver, Colorado

Note: Water table depth shown was estimated on 12/23/93 during vent well construction.



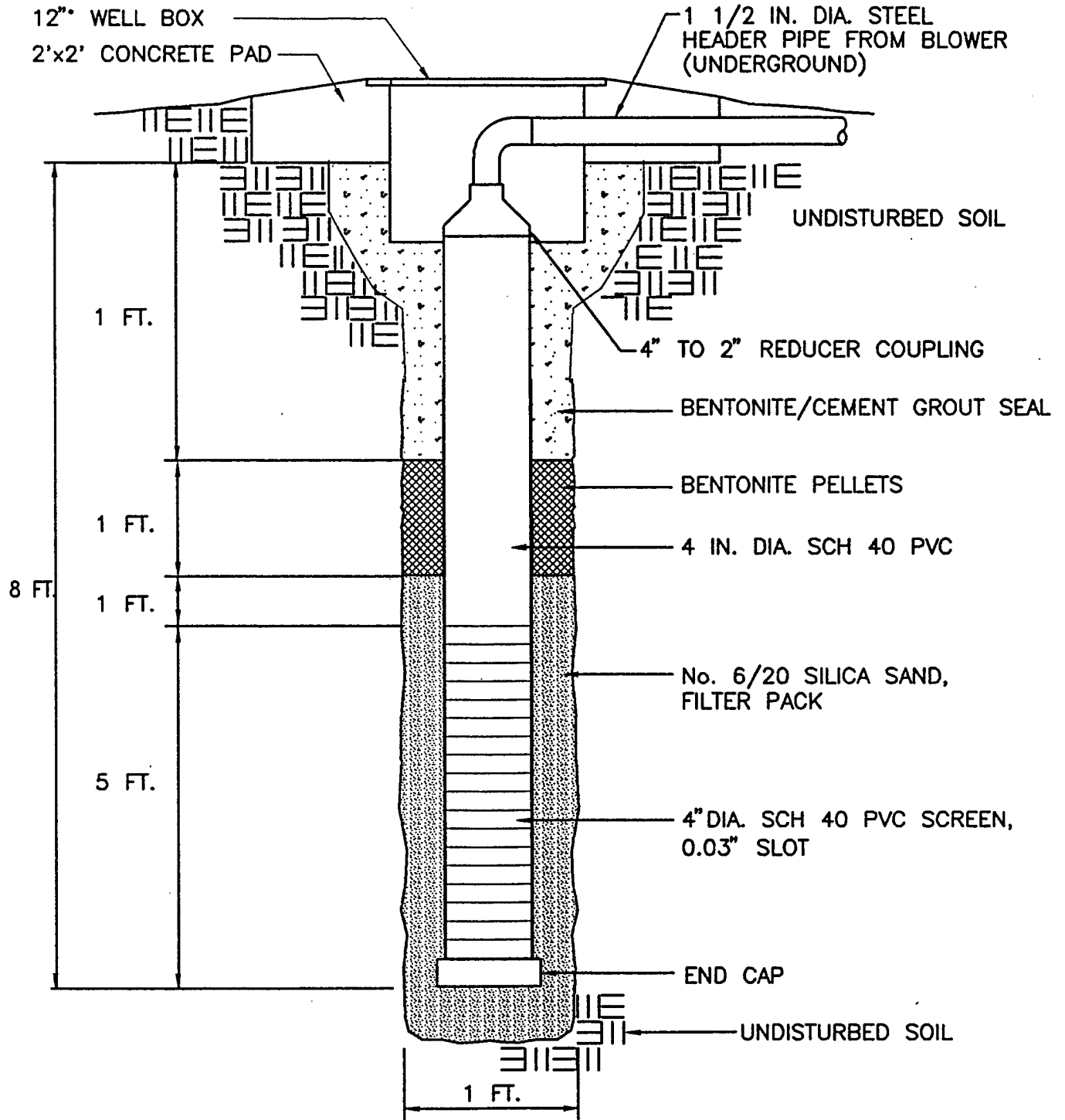

NOT TO SCALE

**AS-BUILT INJECTION VENT  
WELL CONSTRUCTION DETAIL  
FACILITY 44625D**

CAPE CANAVERAL AFS, FLORIDA

ENGINEERING-SCIENCE, INC.  
Denver, Colorado



MPBG, was installed at Facility 1748 in similar soil conditions (see Figure 1.1). All permanent MP boreholes were advanced using a decontaminated stainless steel hand auger. MPA, MPB, and MPC each were screened at 2.5-3.0 and 5.0-5.5 feet bls.

All three permanent MPs were constructed using 0.5-inch-diameter PVC screens and casing installed in 4-inch-diameter boreholes. Each MP was constructed using a 6-inch section of 0.02-inch slotted, Schedule 40 PVC screen and Schedule 80 PVC casing. The screened interval was surrounded by a filter pack of 6/20 graded coarse silica sand.

Thermocouples were also installed at the screened intervals of MPA and MPC. Bentonite pellets, hydrated in place, were used to seal the annulus around each MP riser above the gravel pack and between the screened intervals. Then a 1-foot grout seal was placed over the bentonite to ground surface. The top of each MP PVC riser was completed at ground surface with a brass ball valve and a 0.25-inch brass hose barb. Each MP was completed at the surface with a 8-inch flush-mounted steel manhole set in a concrete 2x2-foot pad. The lid to the manhole was set approximately 1 inch above ground surface, and the concrete base was sloped toward the edges to promote drainage of surface water away from the MP. Figure 2.4 shows a typical permanent MP construction detail.

### **2.1.3 Blower Unit Installation and Operation**

A 1-horsepower Gast® regenerative blower unit was installed at Facility 44625D for the initial and extended pilot tests. The Gast® blower was installed in a weatherproof enclosure and electrically wired for 115 volt, 30-amp power.

Air is supplied by the blower through a 1.5-inch-diameter above/below ground steel header pipe that is attached to the VW. Figure 2.5 shows the configuration, instrumentation, and specifications for the blower and air injection system.

Prior to departing from the site, ES personnel provided O&M instructions to AFS personnel. A copy of these instructions is provided in Appendix A.

## **2.2 SOIL AND SOIL GAS SAMPLING RESULTS**

Soils at Facility 44625D consist of loose, fine- to coarse-grained sand, with shell fragments. This soil profile was consistent across the site at each boring location from ground surface to below the water table surface, which typically averages 6 to 8 feet bls. The fine to coarse sands range in color from gray to dark brown in areas that are stained from fuel and waste oil contamination.

Soil hydrocarbon contamination at this site appears to be mainly within the vicinity of the generator maintenance concrete pad area. Contaminated soils were identified based on visual appearance, odor, and VOC field screening results. Heavily contaminated soils were encountered during the VW installation and during all MP installations. Contaminated soils exhibited hydrocarbon odors and were visibly stained from dark, oily fuel. Soil gas VOC readings ranged from 200 to 2,800 ppmv of total hydrocarbons at the MPs and VW locations.

Soil samples for laboratory analysis were collected from the stainless steel hand-auger bucket during the installation of the permanent MPs. Soil samples were collected from 5.5 feet bls at MPA and MPB, and the VW. Soil samples were screened for

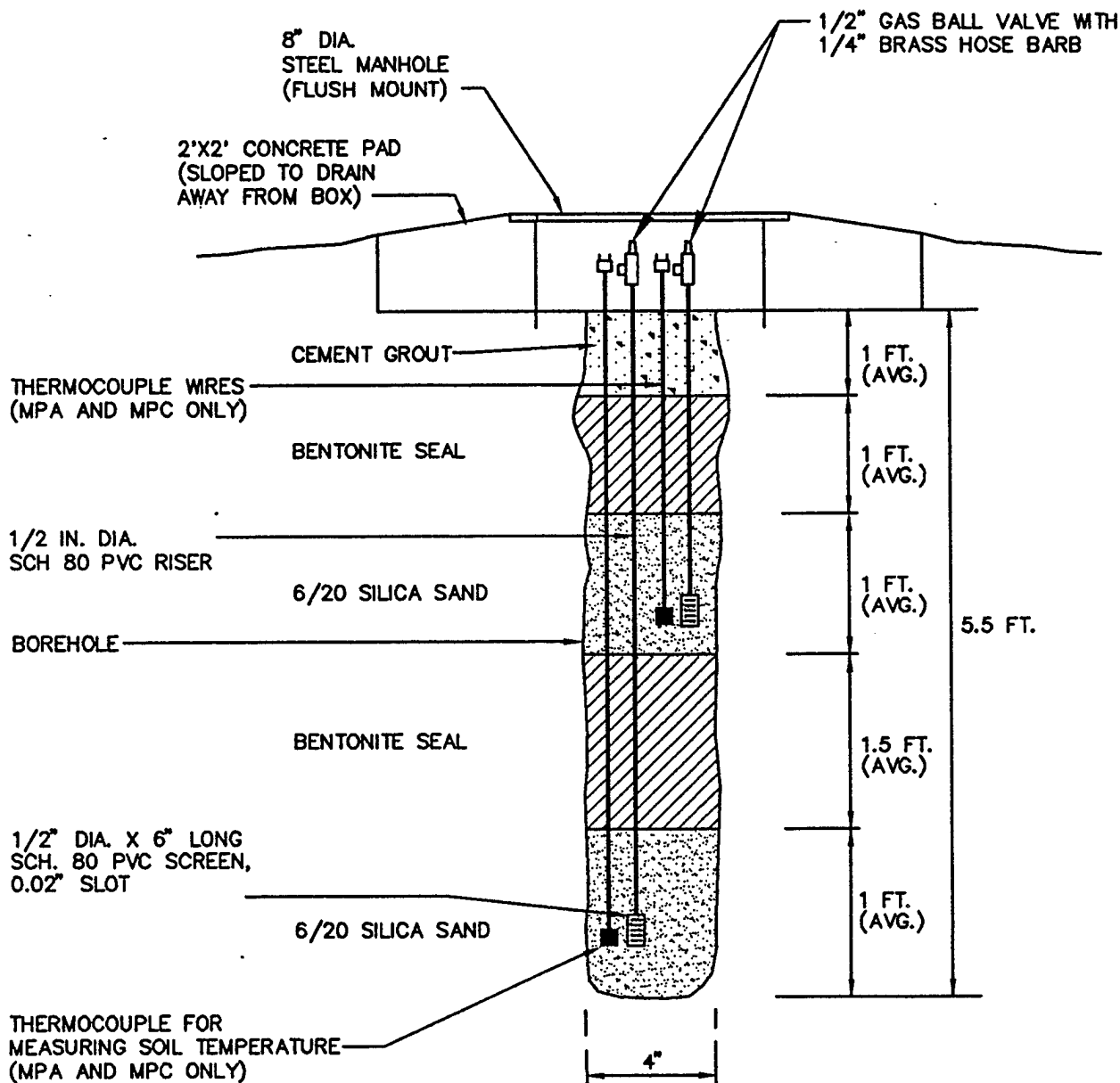

**MONITORING POINT CONSTRUCTION SPECIFICATIONS**

Monitoring Point No.	Borehole Depth (FT)	Screen Interval (Feet BLS)
MPA-3.0 MPA-5.5	5.5	2.5-3.0 5.0-5.5
MPB-3.0 MPB-5.5	5.5	2.5-3.0 5.0-5.5
MPC-3.0 MPC-5.5	5.5	2.5-3.0 5.0-5.5

**BACKGROUND MONITORING POINT**

MP-3.0 MP-5.0 (LOCATED AT FACILITY 1748)	5.5	2.5-3.0 5.0-5.5
--	-----	--------------------

DRAWING IS NOT TO SCALE

**AS-BUILT PERMANENT  
MONITORING POINT CONSTRUCTION DETAIL  
FACILITY 44625D**

CAPE CANAVERAL AFS, FLORIDA

ENGINEERING-SCIENCE, INC.  
Denver, Colorado



- LEGEND**
- ① INLET AIR FILTER
  - ② VACUUM GAUGE (in H<sub>2</sub>O)
  - ③ BLOWER - GAST/70 SCFM @ 20 INCHES H<sub>2</sub>O REGENERATIVE W/1HP DRIVE MOTOR
  - ④ AUTOMATIC PRESSURE RELIEF VALVE
  - ⑤ MANUAL PRESSURE RELIEF (BLEED) VALVE -- 1 1/2" GATE
  - ⑥ IN-LINE 1 1/2" GATE VALVE
  - ⑦ PRESSURE GAUGE (in H<sub>2</sub>O)
  - ⑧ TEMPERATURE GAUGE (F)
  - ⑨ POWER SWITCH/TIMEP BOX
  - ⑩ BREAKER BOX (115V/SINGLE PHASE/30 AMP)
  - ⑪ AIR VELOCITY MEASURE PORT

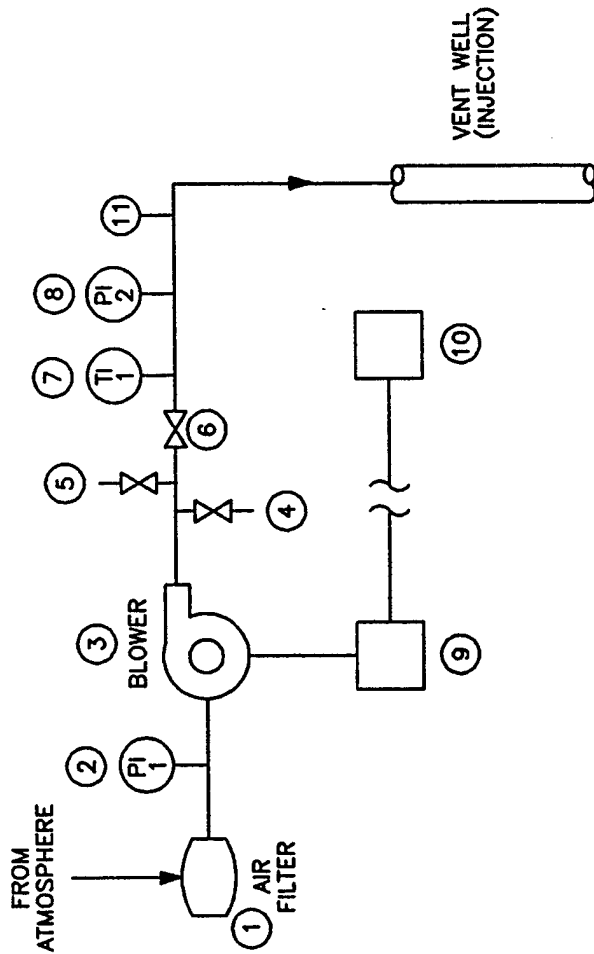

DRAWING IS NOT TO SCALE

**AS-BUILT BLOWER SYSTEM  
FOR AIR INJECTION**

CAPE CANAVERAL AFS., FLORIDA

**ENGINEERING-SCIENCE, INC.**  
Denver, Colorado



VOCs using a GasTech/Trace-techtor® hydrocarbon analyzer to determine the presence of contamination and to select soil samples for laboratory analysis.

Soil samples were shipped via Federal Express® to Pace, Inc. in Huntington Beach, California for chemical and physical analyses. Each of the soil samples were analyzed for BTEX, iron, alkalinity, TKN, pH, phosphates, percent moisture, and grain size distribution. Soil gas samples were shipped via Federal Express® to Air Toxics, Inc. in Folsom, California for TVH and BTEX analyses. The results of these analyses are presented in Table 2.1, and the chain-of-custody form is presented in Appendix C.

### **2.3 EXCEPTIONS TO TEST PROTOCOL DOCUMENT PROCEDURES**

Test procedures described in the protocol document were used to complete the treatability pilot tests at this site. There was one exception to the Bioventing Pilot Test Work Plan (Part I) at Facility 44625D. A multi-depth MP was constructed rather than a single-depth MP.

### **2.4 FIELD QA/QC RESULTS**

Field quality QA/QC samples were not collected or required at this site.

### **2.5 PILOT TEST RESULTS**

#### **2.5.1 Initial Soil Gas Chemistry**

Prior to initiating any air injection, all MPs were purged until oxygen levels had stabilized, and initial oxygen, carbon dioxide, and TVH concentrations were sampled using portable gas analyzers, as described in the technical protocol document (Hinchee et al., 1992). Table 2.2 describes initial soil gas chemistry at the site. At MPA, MPB, MPC, and at the VW, microorganisms had completely depleted soil gas oxygen supplies, indicating significant biological activity and soil contamination. MPBG, located at nearby Facility 1748, had near-atmospheric levels of oxygen and carbon dioxide. This indicates that the uncontaminated soils in the area do not exert any significant oxygen demand due to natural organic biodegradation or abiotic reactions.

#### **2.5.2 Air Permeability**

An air permeability test was conducted according to protocol document procedures. Air was injected into the VW for 4 hours at a rate of approximately 64 scfm and an average pressure of 21 inches of water. Steady-state pressure levels were achieved in all MPs after only 3 minutes of air injection. Table 2.3 provides the steady-state pressures at each MP. Due to this rapid pressure response, the steady-state method of determining air permeability was selected. A soil gas permeability value of 79 darcys, typical for sandy soils, was calculated for this site. A radius of pressure influence of approximately 30 feet was observed at this site.

#### **2.5.3 Oxygen Influence**

The radius of oxygen increase in the subsurface resulting from air injection into the VW during pilot testing is an important design parameter for full-scale bioventing systems. Optimization of full-scale and multiple vent well systems requires pilot

**TABLE 2.1**  
**SOIL AND SOIL GAS LABORATORY ANALYTICAL RESULTS**  
**FACILITY 44625D**  
**CAPE CANAVERAL AFS, FLORIDA**

Analyte (Units) <sup>a/</sup>	Sample Location-Depth (feet below land surface)		
	<u>VW 3-6.5</u>	<u>MPA-5.5</u>	<u>MPC-5.5</u>
<u>Soil Gas Hydrocarbons</u>			
TVH (ppmv)	350	510	330
Benzene (ppmv)	0.26	0.80	ND
Toluene (ppmv)	0.19	0.32	0.10
Ethylbenzene (ppmv)	ND <sup>b/</sup>	ND	ND
Xylenes (ppmv)	1.3	2.2	1.2
	<u>VWC-5.5</u>	<u>MPA-5.5</u>	<u>MPB-5.5</u>
<u>Soil Hydrocarbons</u>			
TRPH (mg/kg)	8,440	8,000	15,000
Benzene (mg/kg)	ND	ND	ND
Toluene (mg/kg)	ND	ND	ND
Ethylbenzene (mg/kg)	ND	ND	ND
Xylenes (mg/kg)	1.3	1.7	ND
<u>Soil Inorganics</u>			
Iron (mg/kg)	1,900	1,220	1,020
Alkalinity (mg/kg as CaCO <sub>3</sub> )	270	233	293
pH (units)	9.2	9.1	9.2
TKN (mg/kg)	76	80	66
Phosphates (mg/kg)	210	160	200
<u>Soil Physical Parameters</u>			
Soil Temperature (°F) <sup>d/</sup>	NS <sup>c/</sup>	70.8	NS
Moisture (% wt.)	7.7	6.1	5.1
Gravel (%)	0.2	3.8	0.5
Sand (%)	98	* 93.2	96.5
Silt (%)	0.8	0.7	0.5
Clay (%)	2.6	2.2	2.5

- a/ TRPH = total recoverable petroleum hydrocarbons; TPH = total petroleum hydrocarbons; mg/kg = milligrams per kilogram, ppmv = parts per million, volume per volume; CaCO<sub>3</sub> = calcium carbonate; TKN = total Kjeldahl nitrogen.
- b/ ND = not detected.
- c/ NS = not sampled.
- d/ Soil temperature at MPC-5.5 was 70.5°F.

**TABLE 2.2**  
**INITIAL SOIL GAS CHEMISTRY**  
**FACILITY 44625D**  
**CAPE CANAVERAL AFS, FLORIDA**

Sample Location	Depth (ft)	O <sub>2</sub> (%)	CO <sub>2</sub> (%)	Field TVH (ppmv) <sup>a/</sup>	Lab TVH (ppmv) <sup>b/</sup>	Lab TRPH (mg/kg) <sup>c/</sup>
MPA	5.5	0.0	15.8	260	510	8,000
MPB	5.5	0.0	15.9	280	NS <sup>c/</sup>	15,000
MPC	5.5	0.0	16.9	200	330	NS
VW	3-6.5	0.0	16.0	200	350	8,440
MPBG	3.0	20.5	0.5	0.0	NS	NS
	5.5	20.3	0.7	0.0	NS	NS

a/ Gastech/Trace-techtor<sup>®</sup> field screening results.

b/ Laboratory results.

c/ NS = not sampled.

**TABLE 2.3**  
**MAXIMUM PRESSURE RESPONSE**  
**AIR PERMEABILITY TEST**  
**FACILITY 44625D**  
**CAPE CANAVERAL AFS, FLORIDA**

	Distance from injection well (VW) (feet)					
	10 (MPA)		20 (MPB)		30 (MPC)	
Depth (feet)	3.0	5.5	3.0	5.5	3.0	5.5
Time (min)	10.0	10.0	10.0	10.0	10.0	10.0
Max Press (inches H <sub>2</sub> O)	3.3	3.6	2.2	2.4	0.08	0.18

testing to determine the volume of soil that can be oxygenated at a given flow rate and vent well screen configuration.

Table 2.4 presents the change in soil gas oxygen levels that occurred after 4 hours of continuous air injection. This period of air injection, at approximately 64 scfm, produced changes in soil gas oxygen levels at least 30 feet from the VW. Based on this rapid change in oxygen levels, it is anticipated that the radius of oxygen influence for a long-term bioventing system at this site will exceed 30 feet. During the startup of the extended pilot test system, the air injection rate will be reduced to the minimum flow required to provide oxygen within a radius of 30 feet from the VW. Based on similar systems constructed in sandy soils, it is anticipated that an air injection rate of approximately 20 scfm will be sufficient for extended testing.

#### **2.5.4 *In Situ* Respiration Rates**

The *in situ* respiration test was performed by injecting a mixture of air (oxygen) and approximately 5 to 6 percent helium (inert tracer gas) into MPA-5.5, MPB-5.5, and MPC-5.5 for a 20-hour period. Oxygen loss and other changes in soil gas composition over time were then measured at each MP. Oxygen, TVH, carbon dioxide, and helium were measured for a period of approximately 80 hours following air injection. The measured oxygen losses were then used to calculate biological oxygen utilization rates. The results of *in situ* respiration testing for MPA, MPB, and MPC are presented in Figures 2.6 through 2.8. Table 2.5 provides a summary of the oxygen utilization rates.

Because helium is a conservative, inert gas, the change in helium concentrations over time can be useful in determining the effectiveness of the bentonite seals above MP screened intervals. Figures 2.6 through 2.8 compare oxygen utilization and helium retention. Although the helium recovery at this site was slightly erratic, the loss of helium from the soil was less than the steady rate of oxygen utilization. Because helium will diffuse approximately three times faster than oxygen due to oxygen's greater molecular weight, the measured oxygen loss is primarily the result of bacterial respiration and not due to oxygen diffusion or oxygen loss from leaks in the MPs.

Oxygen loss occurred at moderate rates ranging from 0.004 %/min at MPB-5.5 to 0.008 %/min at MPC-5.5. Based on test results an estimated 1,640 at MPB-5.5 to 3140 at MPC-5.5 mg of fuel per kg of soil can be degraded each year at this site. This estimate is based on an average air-filled porosity of approximately 0.19 liter per kg of soil, and a conservative ratio of 3.5 mg of oxygen consumed for every 1 mg of fuel biodegraded. Additional information on the calculation for fuel biodegradation can be found in Section 5 of the protocol (Hinchee et al., 1992). Actual rates will vary and could be reduced during the rainy season due to higher soil moisture and reduced air-filled porosity.

#### **2.5.5 Potential For Air Emissions**

The long-term potential for air emissions from full-scale bioventing operations at this site is considered low because of the low injection rate proposed for extended testing (<20 scfm) and the fact that initial soil gas total BTEX level was less than 4 ppmv. Health and safety monitoring was conducted during the four hour air permeability tests using a GasTech® hydrocarbon analyzer sensitive to 1-ppmv

**TABLE 2.4**  
**INFLUENCE OF AIR INJECTION AT VENT WELL**  
**ON MONITORING POINT OXYGEN LEVELS**  
**FACILITY 44625D**  
**CAPE CANAVERAL AFS, FLORIDA**

MP	Distance From VW (ft)	Depth (ft bls)	Initial O <sub>2</sub> (%)	<u>Final O<sub>2</sub> (%)</u> Permeability Test <sup>a/</sup>
A	10	3	0.0	NS <sup>b/</sup>
B	20	3	0.0	NS
C	30	3	0.0	19.0
A	10	5.5	0.0	NS
B	20	5.5	0.0	NS
C	30	5.5	0.0	19.9

a/ Reading taken at end of 4 hours of air injection.

b/ Not sampled.

Respiration Test  
 Oxygen and Helium Concentrations  
 Facility 44625D (Generator Shop - Drum Storage Area), MPA-5.5  
 Cape Canaveral AFS, FL

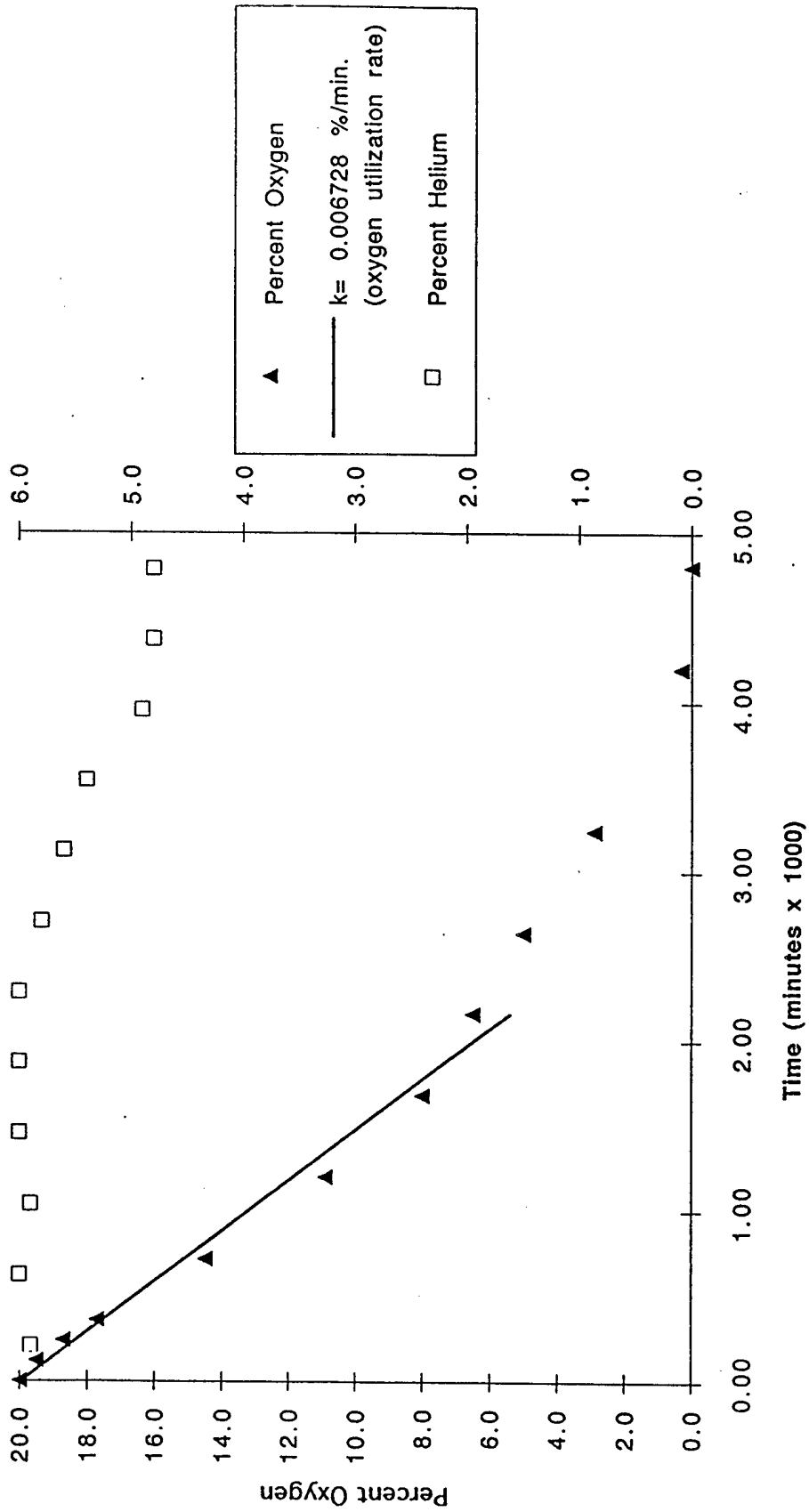

Figure 2.6

Respiration Test  
 Oxygen and Helium Concentrations  
 Facility 44625D (Generator Shop - Drum Storage Area), MPB-5.5  
 Cape Canaveral AFS, FL

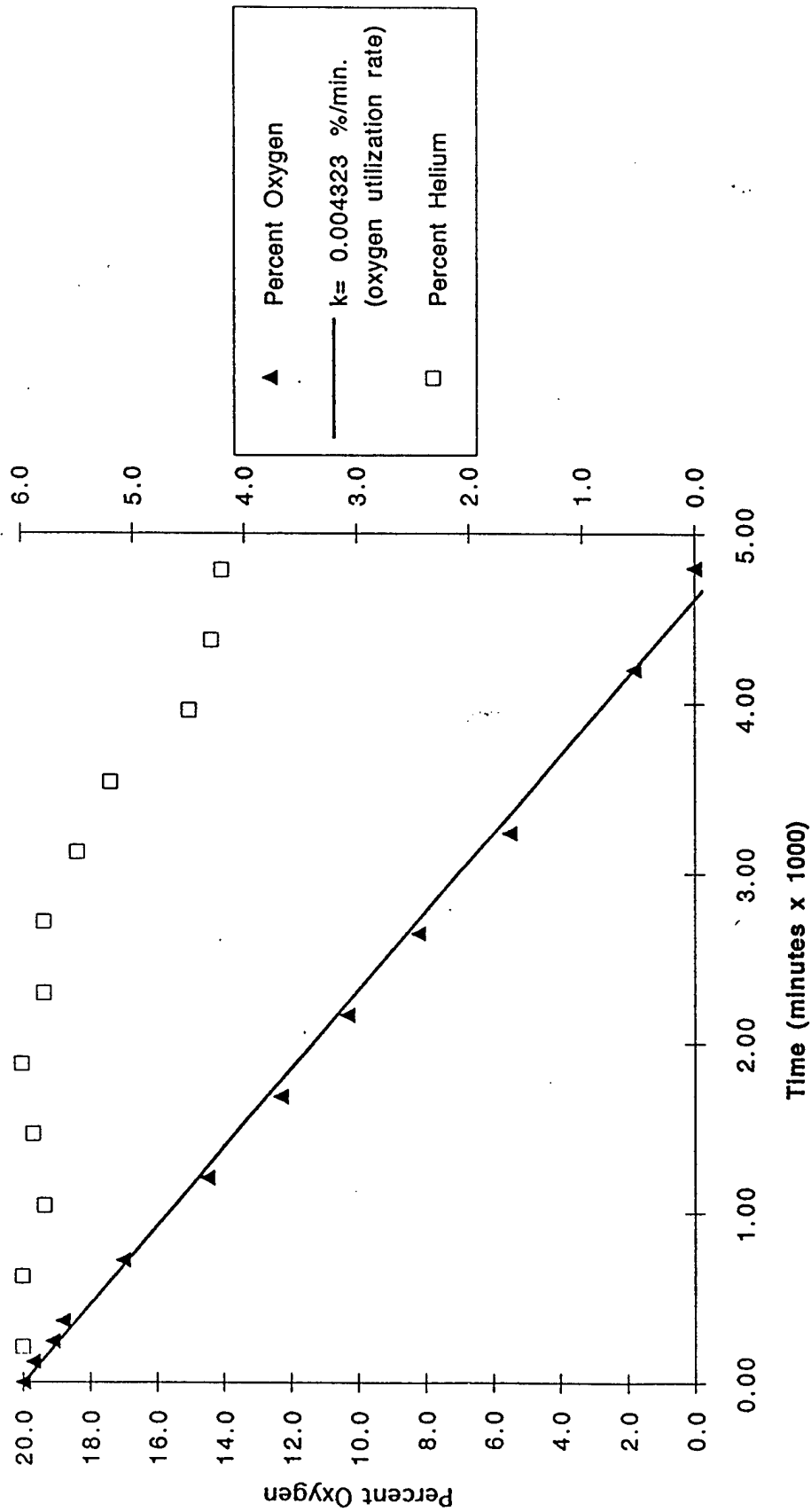

Figure 2.7

Respiration Test  
 Oxygen and Helium Concentrations  
 Facility 44625D (Generator Shop - Drum Storage Area), MPC-5.5  
 Cape Canaveral AFS, FL

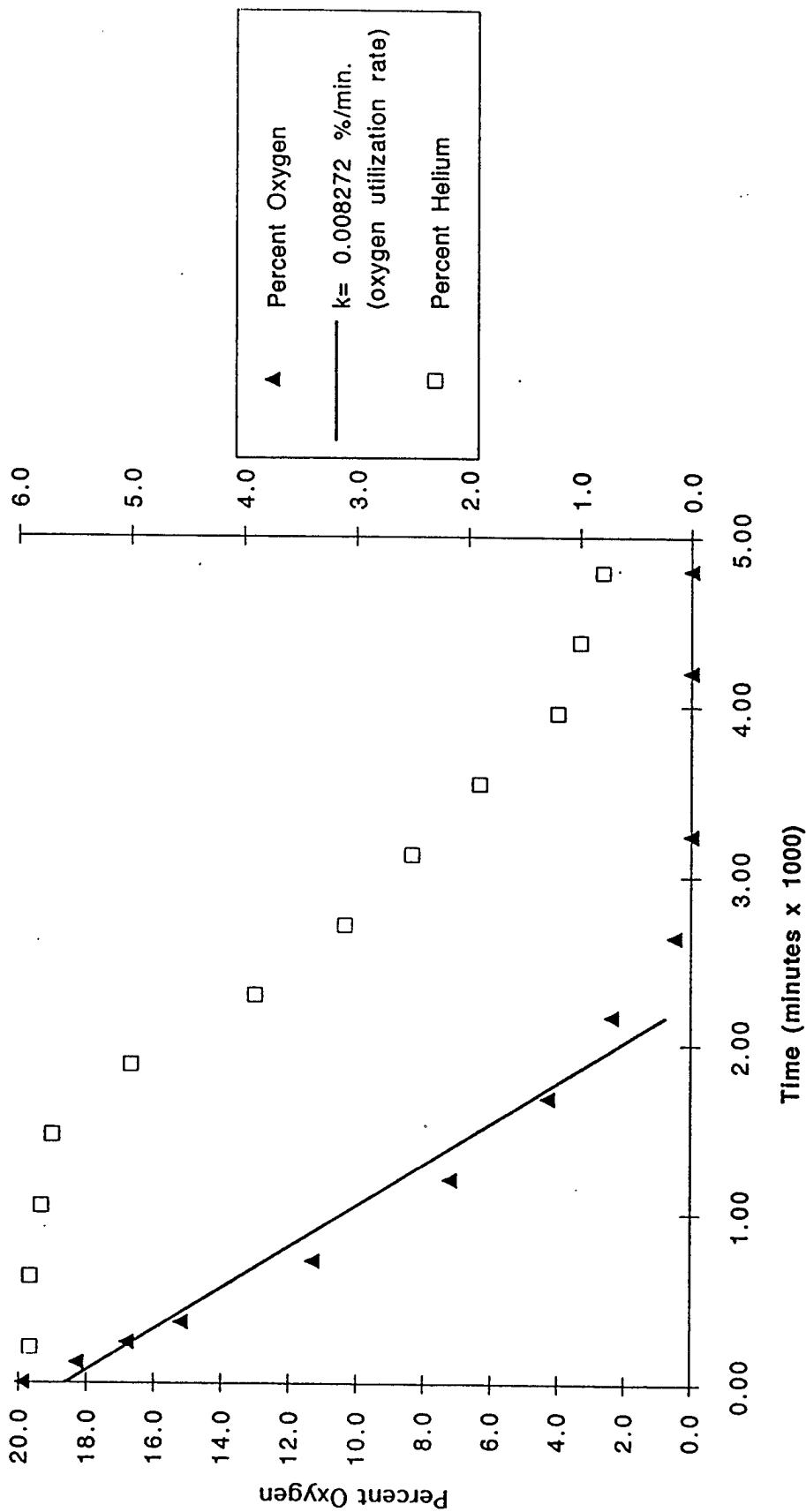

Figure 2.8

**TABLE 2.5**  
**OXYGEN UTILIZATION RATES**  
**FACILITY 44625D**  
**CAPE CANAVERAL AFS, FLORIDA**

Location	O <sub>2</sub> Loss <sup>a/</sup> (%)	Test <sup>b/</sup> Duration	O <sub>2</sub> Utilization <sup>c/</sup> Rate (%/min)
MPA-5.5	20.0	4,920	0.0067
MPB-5.5	20.0	4,920	0.0043
MPC-5.5	19.9	3,240	0.0083

a/ Actual measured oxygen loss.

b/ Elapsed time from beginning of test to time when minimum oxygen concentration was measured.

c/ Values based on best-fit lines (Figures 2.6 through 2.8).

increases in volatile hydrocarbons. No emissions in excess of 1 ppmv were detected in the breathing zone during the 4-hour period. Because the potential for air emissions is highest during this initial hour of air injection, the long-term emission potential is considered low.

### **3.0 FACILITY 44625E**

#### **3.1 Pilot Test Design and Construction**

The following sections describe the final design and installation of the bioventing system at Facility 44625E, the generator shop maintenance area. An air injection VW was installed on December 23, 1993 by ES and Groundwater Protection, Inc. (Drilling Division), both of Orlando, Florida. Three permanent pressure/vapor MPs were installed on December 30, 1993. The VW construction, MP installations, and soil sampling were directed by Mr. Steve Archabal, the ES site manager. The following sections describe in more detail the final design, installation, and testing of the bioventing system at this site.

One VW, three permanent MPs, and a blower unit in a weatherproof enclosure were installed at Facility 44625E. The locations of the MPs and VW followed the original work plan found in Part I of this report. A multi-depth MP construction was used at the site. Monitoring depth screen intervals of 2.5 to 3.0 and 5.0 to 5.5 feet bls were installed at this site. Figure 3.1 depicts the test area with the locations of the MPs, VW, and blower at Facility 44625E. Figure 3.2 shows a hydrogeologic cross section oriented in an east-west direction.

##### **3.1.1 Air Injection Venting Well Construction**

The VW was installed within the vicinity of the generator maintenance area, as shown in Figure 3.1. The VW was constructed in visibly contaminated, oxygen-depleted soils. Soils encountered during the VW construction were darkly stained and emitted strong hydrocarbon odors.

The installation of the VW was in accordance with typical AFCEE work plan protocols (Hinchee et al., 1992). On the date of the VW installation, water level at Facility 44625E was approximately 6.5 feet bls.

The VW was constructed using 4-inch diameter, Schedule 40 PVC casing with 5 feet of 0.03-inch slotted PVC screen installed from 3 to 8 feet bls. The annular space between the well casing and borehole was filled with 6/20 graded silica sand to approximately 1 foot above the well screen. A 1-foot layer of bentonite pellets were placed above the sand and hydrated in place. A 1-foot cement grout seal was placed over the bentonite to ground surface. The top of each VW was completed with a flush-mount steel well manhole set in a 2x2-foot concrete pad. Figure 3.3 shows the as-built construction details for the VW. The geologic soil boring log for the VW installations is provided in Appendix B.

##### **3.1.2 Permanent Monitoring Points**

Three permanent multi-depth MPs were installed at Facility 44625E on December 30, 1993. MPs CA4-MPA, CA4-MPB, and CA4-MPC were installed at respective distances of 10, 20, and 30 feet from the VW location. A permanent background MP,

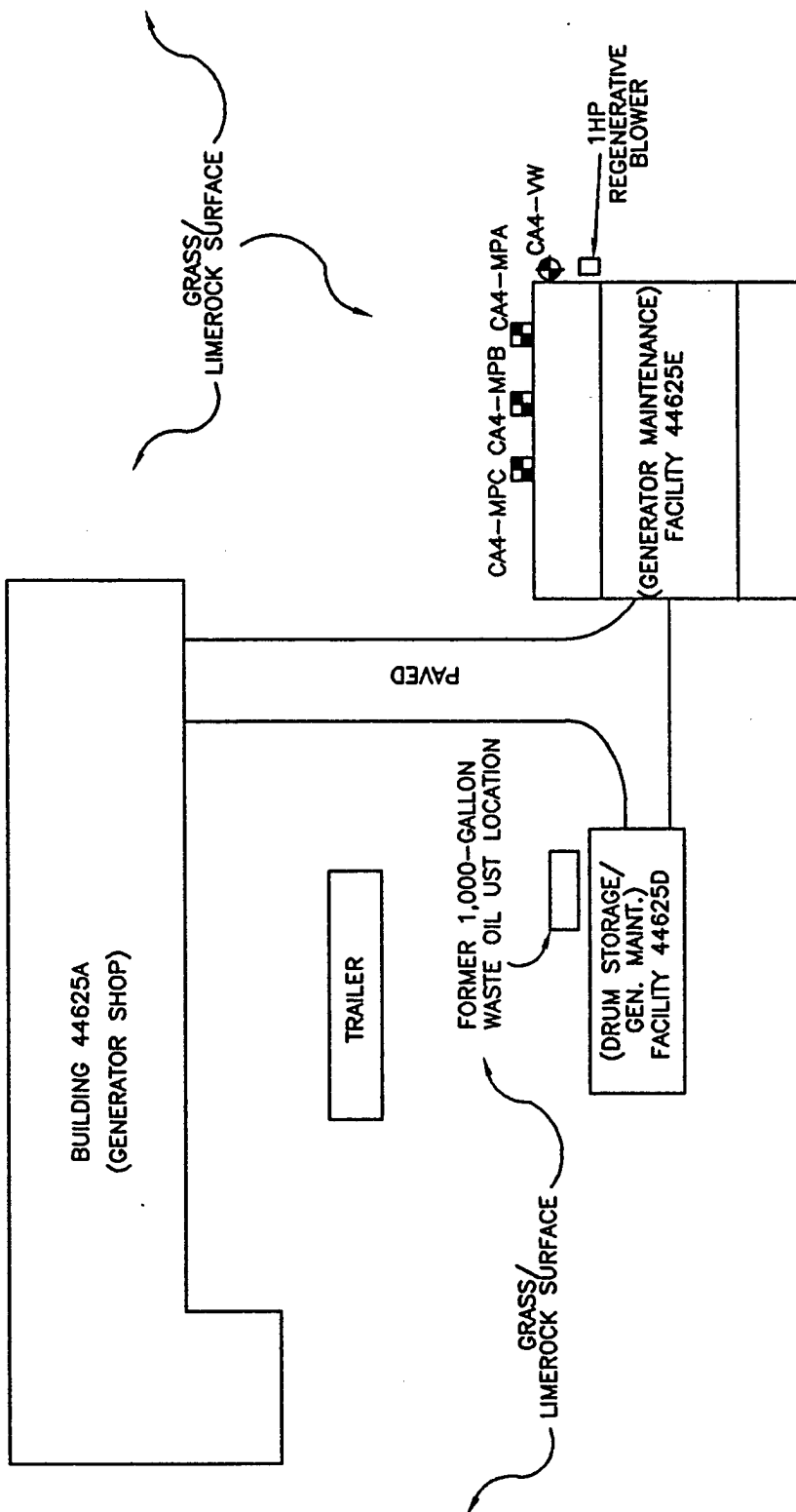

LEGEND

- ◊ = AIR INJECTION WELL
- ◻ = VAPOR MONITORING POINT

CA4-MPA

**AS-BUILT VENTING WELL  
VAPOR MONITORING POINTS,  
AND BLOWER LOCATIONS  
FACILITY 44625E**

CAPE CANAVERAL AFS, FLORIDA  
**ENGINEERING-SCIENCE, INC.**  
Denver, Colorado



Figure 3.2

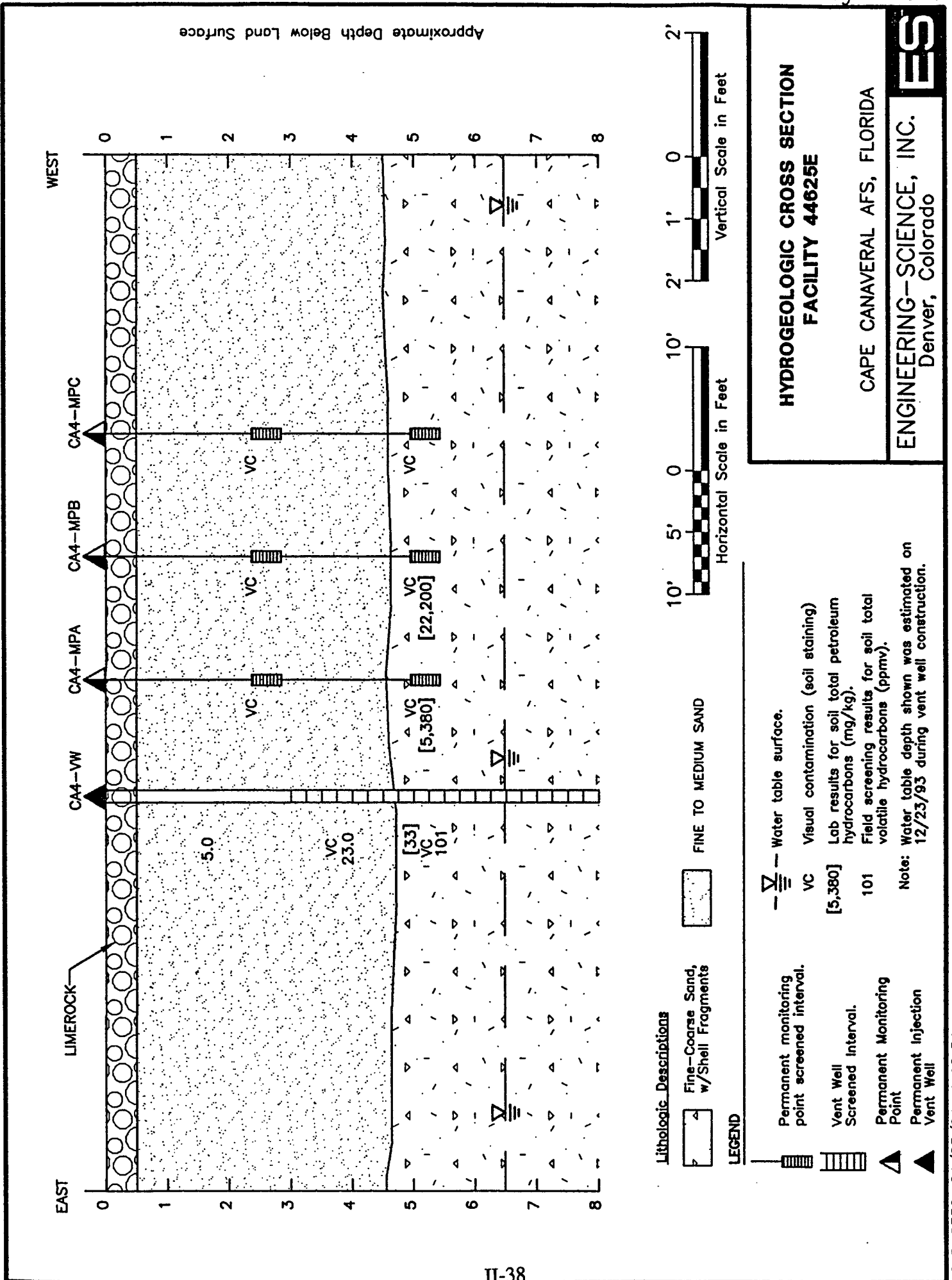

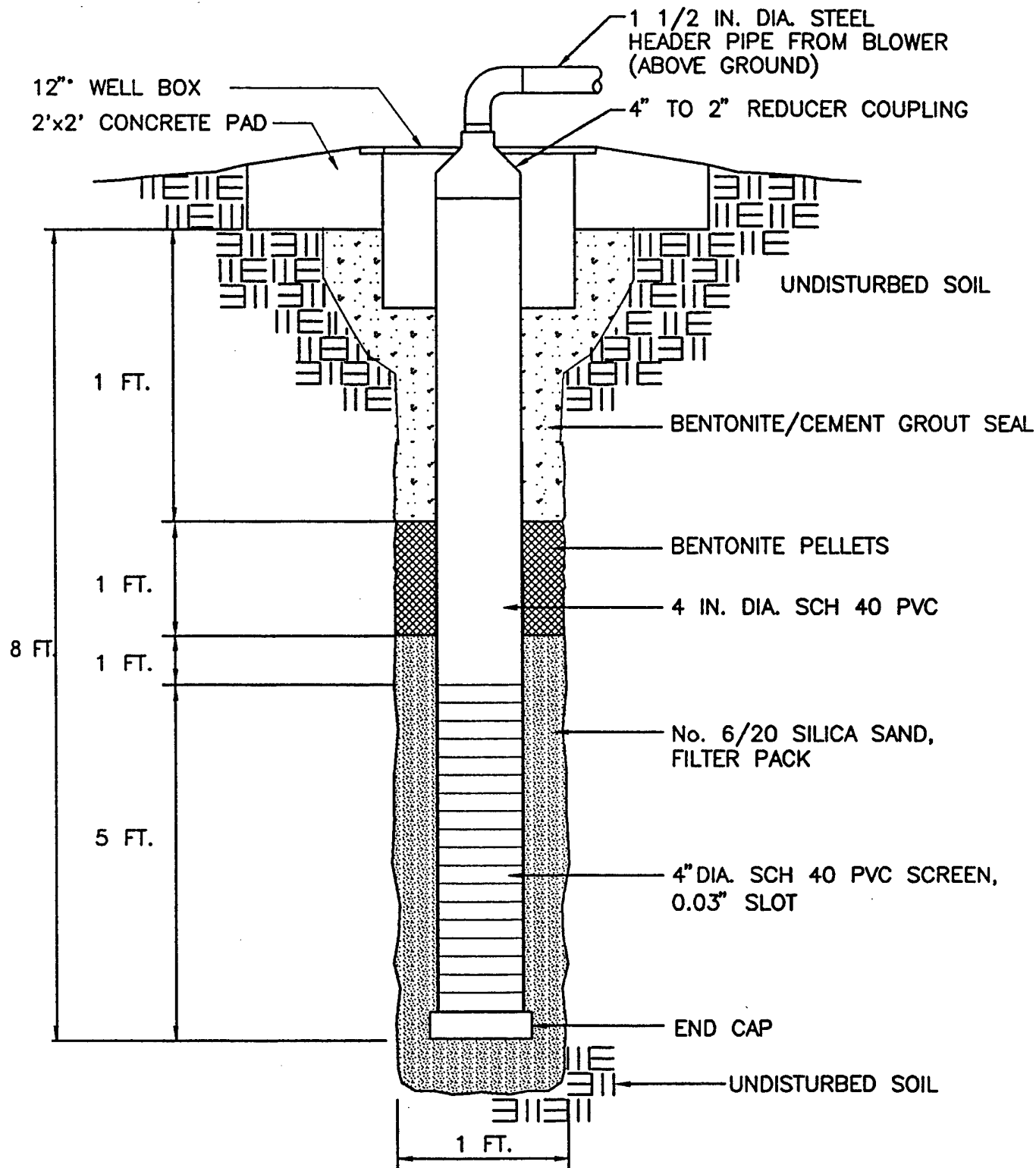

NOT TO SCALE

**AS-BUILT INJECTION VENT  
WELL CONSTRUCTION DETAIL  
FACILITY 44625E**

CAPE CANAVERAL AFS, FLORIDA

ENGINEERING-SCIENCE, INC.  
Denver, Colorado



MPBG, was installed at Facility 1748 (see Figure 1.1). All permanent MP boreholes were advanced using a decontaminated stainless steel hand auger. MPA, MPB, and MPC were screened at 2.5 to 3.0 and 5.0 to 5.5 feet bls.

All three permanent MPs were constructed using 0.5-inch-diameter PVC screens and casing installed in 4-inch-diameter boreholes. Each MP was constructed using a 6-inch section of 0.02-inch slotted, Schedule 40 PVC screen and Schedule 80 PVC casing. The screened interval was surrounded by a filter pack of 6/20 graded coarse silica sand.

Thermocouples were also installed at the screened intervals of MPA and MPC only. Bentonite pellets, hydrated in place, were used to seal the annulus around each MP riser above the gravel pack and between the screened intervals. A 1-foot grout seal was placed over the bentonite to ground surface. The top of each MP PVC riser was completed at ground surface with a brass ball valve and a 0.25-inch brass hose barb. Each MP was completed at the surface with an 8-inch, flush-mounted steel manhole set in a concrete 2x2-foot pad. The lid to the manhole was set approximately 1 inch above ground surface, and the concrete base was sloped toward the edges to promote drainage of surface water away from the MP. Figure 3.4 shows a typical permanent MP construction detail.

### 3.1.3 Blower Unit Installation and Operation

A 1-horsepower Gast® regenerative blower unit was installed at Facility 44625E for the initial and extended pilot tests. The Gast® blower was installed in a weatherproof enclosure and electrically wired for 115-volt, 30-amp power.

Air is supplied by the blower through a 1.5-inch-diameter, aboveground steel header pipe that is attached to the VW. Figure 3.5 shows the configuration, instrumentation, and specifications for the blower and air injection system.

Prior to departing from the site, ES personnel provided O&M instructions to AFS personnel. A copy of these instructions is provided in Appendix A.

## 3.2 SOIL AND SOIL GAS SAMPLING RESULTS

Soils at Facility 44625E consist of loose, fine- to coarse-grained sand, with shell fragments. This soil profile was consistent across the site at each boring location from ground surface to below the water table surface, which typically averages 6 to 8 feet bls. The fine to coarse sands range in color from light gray to dark brown in those areas that are stained from fuel and waste oil contamination.

Soil hydrocarbon contamination at this site appears to be confined mainly within the generator maintenance pad area. Contaminated soils were identified based on visual appearance, odor and VOC field screening results. Heavily contaminated soils were encountered during the VW installation and during all MP installations. Contaminated soil exhibited hydrocarbon odors and was visibly stained from dark oily fuel. Soil gas VOC readings ranged from 280 to 14,800 ppmv of total hydrocarbons at the MP and VW locations.

Soil samples for laboratory analysis were collected from the stainless steel hand-auger bucket during the installation of the permanent MPs. Soil samples were collected from 5.5 feet bls at MPA, MPB, and the VW. Soil samples were screened for VOCs

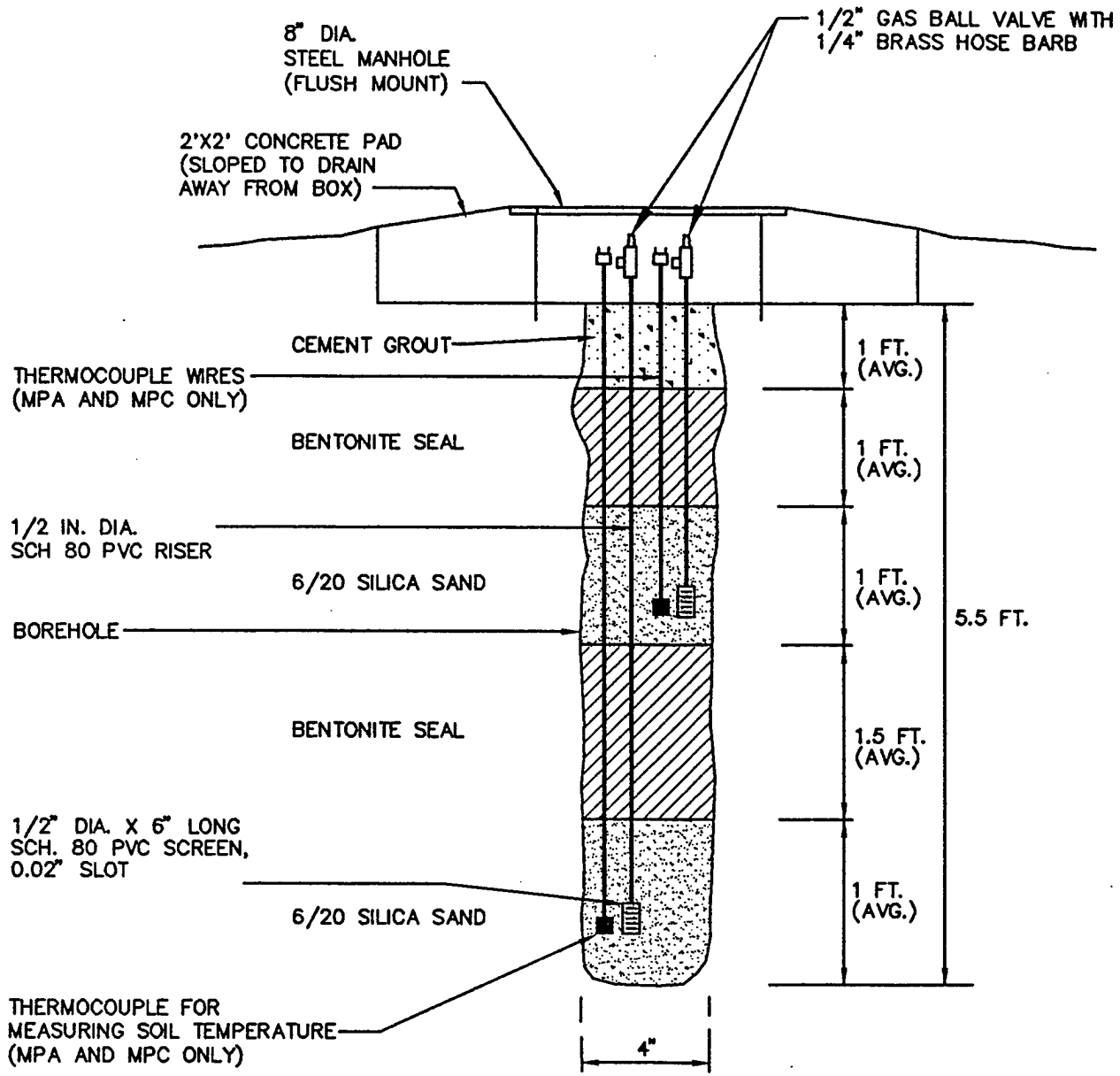

**MONITORING POINT CONSTRUCTION SPECIFICATIONS**

Monitoring Point No.	Borehole Depth (FT)	Screen Interval (Feet BLS)
MPA-3.0 MPA-5.5	5.5	2.5-3.0 5.0-5.5
MPB-3.0 MPB-5.5	5.5	2.5-3.0 5.0-5.5
MPC-3.0 MPC-5.5	5.5	2.5-3.0 5.0-5.5

**BACKGROUND MONITORING POINT**

MP-3.0 MP-5.0 (LOCATED AT FACILITY 1748)	5.5	2.5-3.0 5.0-5.5
--	-----	--------------------

DRAWING IS NOT TO SCALE

**AS-BUILT PERMANENT  
MONITORING POINT CONSTRUCTION DETAIL  
FACILITY 44625E**

CAPE CANAVERAL AFS, FLORIDA

ENGINEERING-SCIENCE, INC.  
Denver, Colorado



- LEGEND**
- ① INLET AIR FILTER
  - ② VACUUM GAUGE (in H<sub>2</sub>O)
  - ③ BLOWER - CAST/70 SCFM @ 20 INCHES H<sub>2</sub>O REGENERATIVE W/1HP DRIVE MOTOR
  - ④ AUTOMATIC PRESSURE RELIEF VALVE
  - ⑤ MANUAL PRESSURE RELIEF (BLEED) VALVE - 1 1/2" GATE
  - ⑥ IN-LINE 1 1/2" GATE VALVE
  - ⑦ PRESSURE GAUGE (in H<sub>2</sub>O)
  - ⑧ TEMPERATURE GAUGE (°F)
  - ⑨ POWER SWITCH/TIMEP BOX
  - ⑩ BREAKER BOX (115V/SINGLE PHASE/30 AMP)
  - ⑪ AIR VELOCITY MEASURE PORT

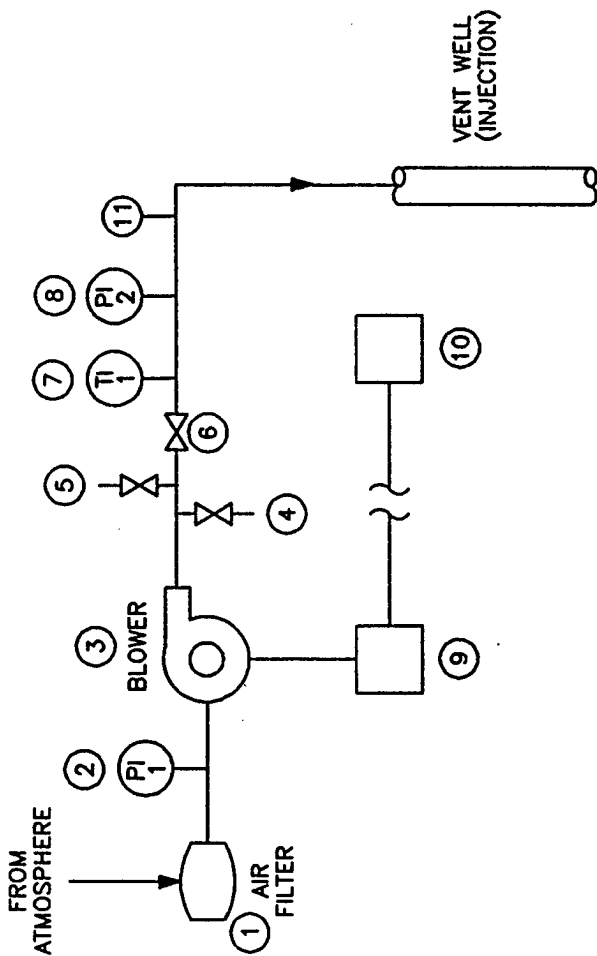

DRAWING IS NOT TO SCALE

**AS-BUILT BLOWER SYSTEM  
FOR AIR INJECTION**

CAPE CANAVERAL AFS., FLORIDA

ENGINEERING-SCIENCE, INC.  
Denver, Colorado



using a GasTech/Trace-techtor<sup>®</sup>, hydrocarbon analyzer to determine the presence of contamination and to select soil samples for laboratory analysis.

Soil samples were shipped via Federal Express<sup>®</sup> to Pace, Inc. in Huntington Beach, California for chemical and physical analyses. Each of the soil samples were analyzed for TRPH, BTEX, iron, alkalinity, TKN, pH, phosphates, percent moisture, and grain size distribution. Soil gas samples were shipped via Federal Express<sup>®</sup> to Air Toxics, Inc. in Folsom, California for TVH and BTEX analyses. The results of these analyses are presented in Table 3.1, and the chain-of-custody form is presented in Appendix C.

### **3.3 EXCEPTIONS TO TEST PROTOCOL DOCUMENT PROCEDURES**

Test procedures described in the protocol document were used to complete treatability pilot tests at this site. There was one exception to the Bioventing Pilot Test Work Plan (Part I) at Facility 44625E. Multi-depth rather than single-depth MP screens were installed to more effectively monitor oxygen influence at this site because soil contamination was present throughout the unsaturated zone.

### **3.4 FIELD QA/QC RESULTS**

Field QA/QC samples were not collected or required at this site.

### **3.5 PILOT TEST RESULTS**

#### **3.5.1 Initial Soil Gas Chemistry**

Prior to initiating any air injection, all MPs were purged until oxygen levels had stabilized, and initial oxygen, carbon dioxide, and TVH concentrations were sampled using portable gas analyzers, as described in the technical protocol document. At all MP screened intervals, microorganisms had completely depleted soil gas oxygen supplies, indicating significant biological activity and soil contamination. The uniformity of zero oxygen levels at this site is primarily the result of the vertical and horizontal uniformity of soil contamination. Table 3.2 describes initial soil gas chemistry at the site. A background MP located at nearby Facility 1748 had near-atmospheric levels of oxygen and carbon dioxide. This indicates that uncontaminated soils at the same depth do not exert significant oxygen demand due to natural organic biodegradation or abiotic reactions.

#### **3.5.2 Air Permeability**

An air permeability test was conducted according to protocol document procedures. Air was injected into the VW for 3 hours at a rate of approximately 55 scfm and an average pressure of 29 inches of water. Steady-state pressure levels were achieved in all MPs after approximately 10 minutes of air injection. Table 3.3 provides the steady-state pressures at each MP. Due to this rapid pressure response, the steady-state method of determining air permeability was selected. A soil gas permeability value of 50 darcys was calculated for this site. At this flow rate, the radius of pressure influence will exceed 30 feet. Based on this test, it appears that a reduced flow rate of 20 scfm will be adequate for providing oxygen to the entire pilot test area.

**TABLE 3.1**  
**SOIL AND SOIL GAS LABORATORY ANALYTICAL RESULTS**  
**FACILITY 44625E**  
**CAPE CANAVERAL AFS, FLORIDA**

Analyte (Units) <sup>a/</sup>	Sample Location-Depth (feet below ground surface)		
	<u>VW 3-6.5</u>	<u>MPA-5.5</u>	<u>MPC-5.5</u>
<u>Soil Gas Hydrocarbons</u>			
TVH (ppmv)	0.25	320	590
Benzene (ppmv)	ND <sup>b/</sup>	ND	0.15
Toluene (ppmv)	ND	0.093	1.5
Ethylbenzene (ppmv)	ND	ND	0.96
Xylenes (ppmv)	ND	0.90	5.6
	<u>VW-5.5</u>	<u>MPA-5.5</u>	<u>MPB-5.5</u>
<u>Soil Hydrocarbons</u>			
TRPH (mg/kg)	33	5,380	22,200
Benzene (mg/kg)	ND	ND	ND
Toluene (mg/kg)	ND	0.6	ND
Ethylbenzene (mg/kg)	ND	ND	1.3
Xylenes (mg/kg)	ND	0.87	20
<u>Soil Inorganics</u>			
Iron (mg/kg)	1,300	894	728
Alkalinity (mg/kg as CaCO <sub>3</sub> )	280	325	455
pH (units)	8.8	9.1	8.5
TKN (mg/kg)	78	63	ND
Phosphates (mg/kg)	250	320	250
<u>Soil Physical Parameters</u>			
Soil Temperature (°F) <sup>d/</sup>	NS <sup>c/</sup>	69.9	NS
Moisture (% wt.)	7.7	5.2	6.2
Gravel (%)	2.4	0.3	0.1
Sand (%)	95.4	97.2	97.8
Silt (%)	0.3	0.8	0.5
Clay (%)	2.5	3.4	2.6

- a/ TRPH = total recoverable petroleum hydrocarbons; TPH = total petroleum hydrocarbons; mg/kg = milligrams per kilogram, ppmv = parts per million, volume per volume; CaCO<sub>3</sub> = calcium carbonate; TKN = total Kjeldahl nitrogen.
- b/ ND = not detected.
- c/ NS = not sampled.
- d/ Soil temperature at MPC-5.5 was 70.1°F

**TABLE 3.2**  
**INITIAL SOIL GAS CHEMISTRY**  
**FACILITY 44625E**  
**CAPE CANAVERAL AFS, FLORIDA**

Sample Location	Depth (ft)	O <sub>2</sub> (%)	CO <sub>2</sub> (%)	Field TVH (ppmv) <sup>a/</sup>	Lab TVH (ppmv) <sup>b/</sup>	Lab TPH (mg/kg) <sup>b/</sup>
MPA	5.5	0.0	16.9	120	320	5,380
MPB	5.5	0.0	16.0	260	NS	22,200
MPC	5.5	0.0	16.0	300	590	NS
VW	3-6.5	11.5	8.0	60	0.25	33
MPBG	3.0	20.5	0.5	0.0	NS	NS
	5.5	20.3	0.7	0.0	NS	NS

- a/ Gastech/Trace-techtor<sup>®</sup> field screening results.  
b/ Laboratory results.  
c/ NS = not sampled.

**TABLE 3.3**  
**MAXIMUM PRESSURE RESPONSE**  
**AIR PERMEABILITY TEST**  
**FACILITY 44625E**  
**CAPE CANAVERAL AFS, FLORIDA**

	Distance from injection well (VW) (feet)					
	10 (MPA)		20 (MPB)		30 (MPC)	
Depth (feet)	3.0	5.5	3.0	5.5	3.0	5.5
Time (min)	10.0	10.0	10.0	10.0	10.0	10.0
Max Press (inches H <sub>2</sub> O)	4.8	5.0	2.4	2.45	1.15	1.20

### 3.5.3 Oxygen Influence

The radius of oxygen increase in the subsurface resulting from air injection into the VW is the primary design parameter for full-scale bioventing at this site. Table 3.4 presents the change in soil gas oxygen levels that occurred during 3 hours of air injection. This period of air injection at approximately 55 scfm produced changes in soil gas oxygen levels at a distance of at least 30 feet from the VW. Based on the pressure influence of at least 30 feet, the long-term radius of oxygen influence should also exceed 30 feet. During the start up of the extended pilot test, the air injection rate will be reduced to the minimum flow required to provide oxygen to soils within a 30-foot radius of the VW. This should ensure oxygenation of the entire contaminated soil volume within the boundaries of the study area.

### 3.5.4 *In Situ* Respiration Rates

The *in situ* respiration test was performed by injecting a mixture of air (oxygen) and approximately 6 percent helium (inert tracer gas) into the deep screened interval of each MP (MPA-5.5, MPB-5.5, and MPC-5.5) for a 20-hour period. Oxygen loss and other changes in soil gas composition over time were then measured at each MP. Oxygen, TVH, carbon dioxide, and helium were measured for a period of approximately 104 hours following air injection. The measured oxygen losses were then used to calculate biological oxygen utilization rates. The results of *in situ* respiration testing for MPA-5.5, MPB-5.5, and MPC-5.5 are presented in Figures 3.6 through 3.8. Table 3.5 provides a summary of the oxygen utilization rates.

Because helium is a conservative, inert gas, the change in helium concentrations over time can be useful in determining the effectiveness of the bentonite seals above MP screened intervals. Figures 3.6 through 3.8 compare oxygen utilization and helium retention. Oxygen loss occurred at a moderate rate, averaging 0.0029 %/min. Based on test results, an estimated average 990 mg of fuel per kg of soil can be degraded each year at this site. This estimate is based on an average air-filled porosity of approximately 0.17 liter per kg of soil, and a conservative ratio of 3.5 mg of oxygen consumed for every 1 mg of fuel biodegraded. Actual rates will vary and could be reduced during the rainy season due to higher soil moisture and reduced air-filled porosity.

Although the helium recovery at this site was slightly erratic, the loss of helium from the soil was less than the steady rate of oxygen utilization. Because helium will diffuse approximately three times faster than oxygen due to oxygen's greater molecular weight, the measured oxygen loss is primarily the result of bacterial respiration and not due to oxygen diffusion or oxygen loss from leaks in the MPs.

### 3.5.5 Potential Air Emissions

The long-term potential for air emissions from full-scale bioventing operations at this site is considered low because of the low injection rate proposed for extended testing (<20 scfm) and the fact that initial soil gas BTEX levels were less than 10 ppmv. Health and safety monitoring was conducted during the 3-hour air permeability tests using a GasTech® hydrocarbon analyzer sensitive to 1-ppmv increases in volatile hydrocarbons. No emissions in excess of 1 ppmv were detected in the breathing zone

**TABLE 3.4**  
**INFLUENCE OF AIR INJECTION AT VENT WELL**  
**ON MONITORING POINT OXYGEN LEVELS**  
**FACILITY 44625E**  
**CAPE CANAVERAL AFS, FLORIDA**

MP	Distance From VW (ft)	Depth (ft)	Initial O <sub>2</sub> (%)	<u>Final O<sub>2</sub> (%)</u> Permeability Test <sup>a/</sup>
A	10	3	0.0	NS <sup>b/</sup>
B	20	3	0.0	NS
C	30	3	0.0	5.0
A	10	5.5	0.0	NS
B	20	5.5	0.0	NS
C	30	5.5	0.0	16.5

a/ Reading taken at end of 3 hours of air injection.

b/ Not sampled.

Respiration Test  
 Oxygen and Helium Concentrations  
 Facility 44625E (Generator Shop - Maintenance Area), MPA-5.5  
 Cape Canaveral AFS, FL

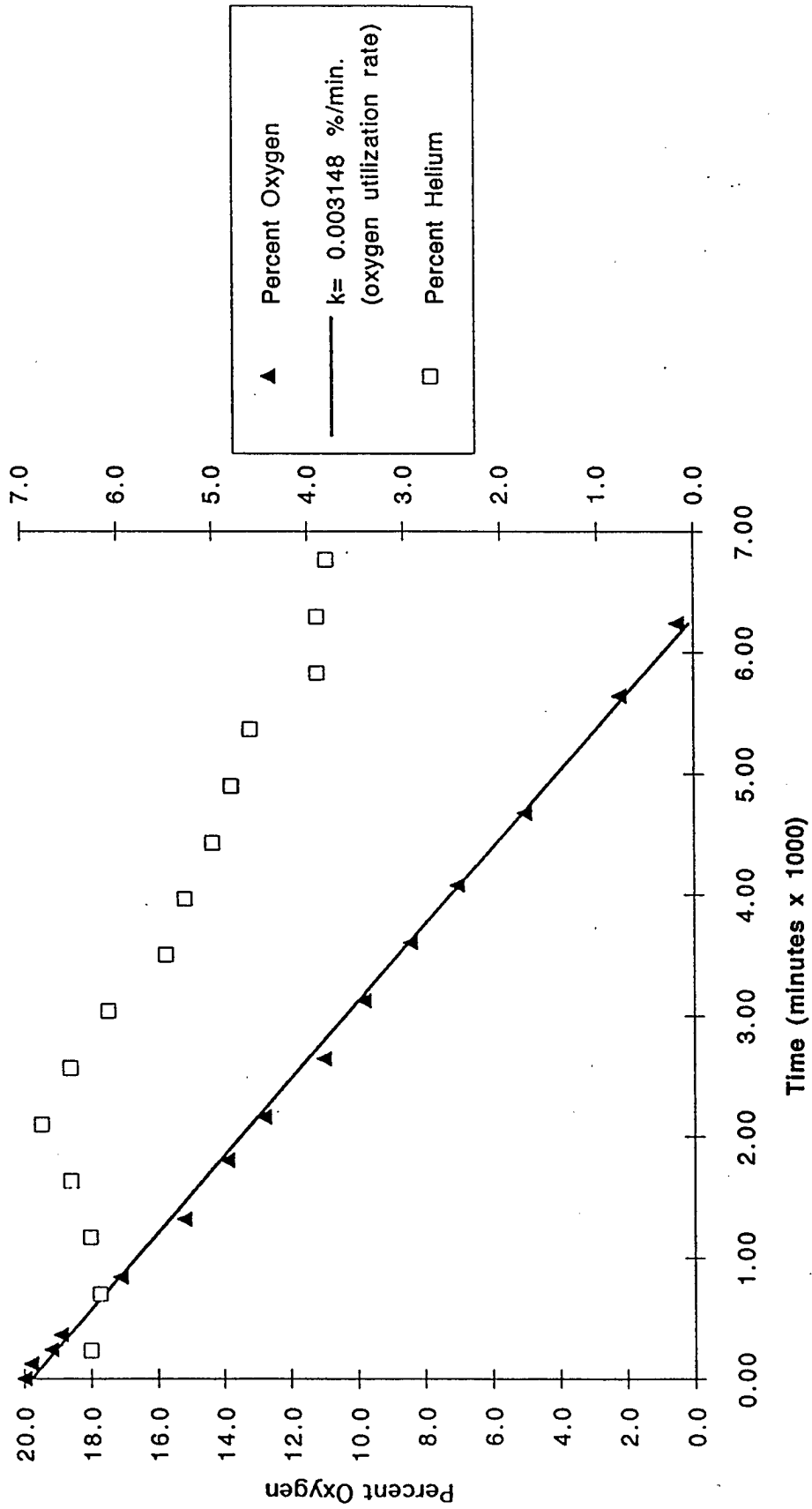

Figure 3.6

Respiration Test  
 Oxygen and Helium Concentrations  
 Facility 44625E (Generator Shop - Maintenance Area), MPB-5.5  
 Cape Canaveral AFS, FL

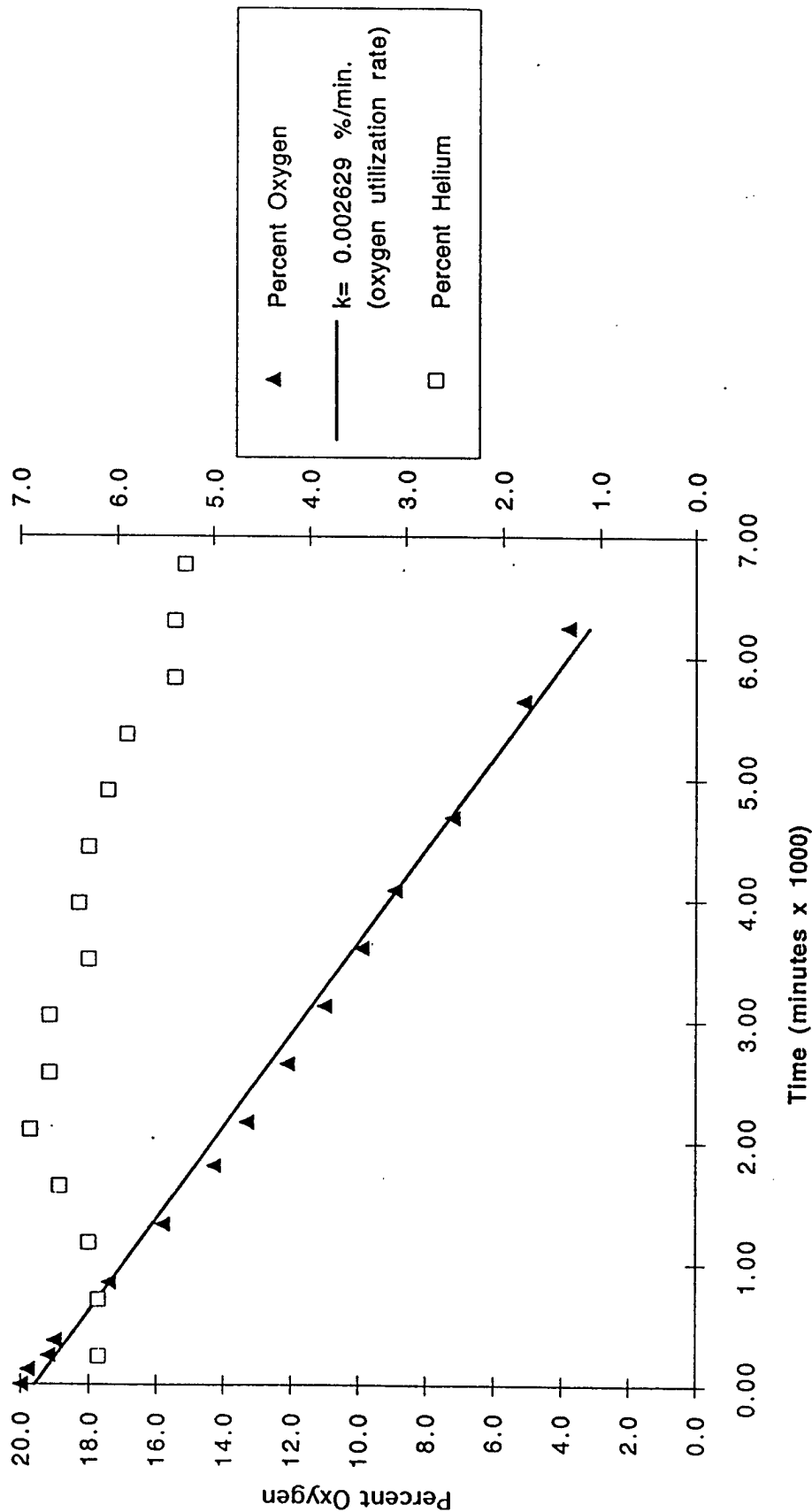

Figure 3.7

Respiration Test  
 Oxygen and Helium Concentrations  
 Facility 44625E (Generator Shop - Maintenance Area), MPC-5.5  
 Cape Canaveral AFS, FL

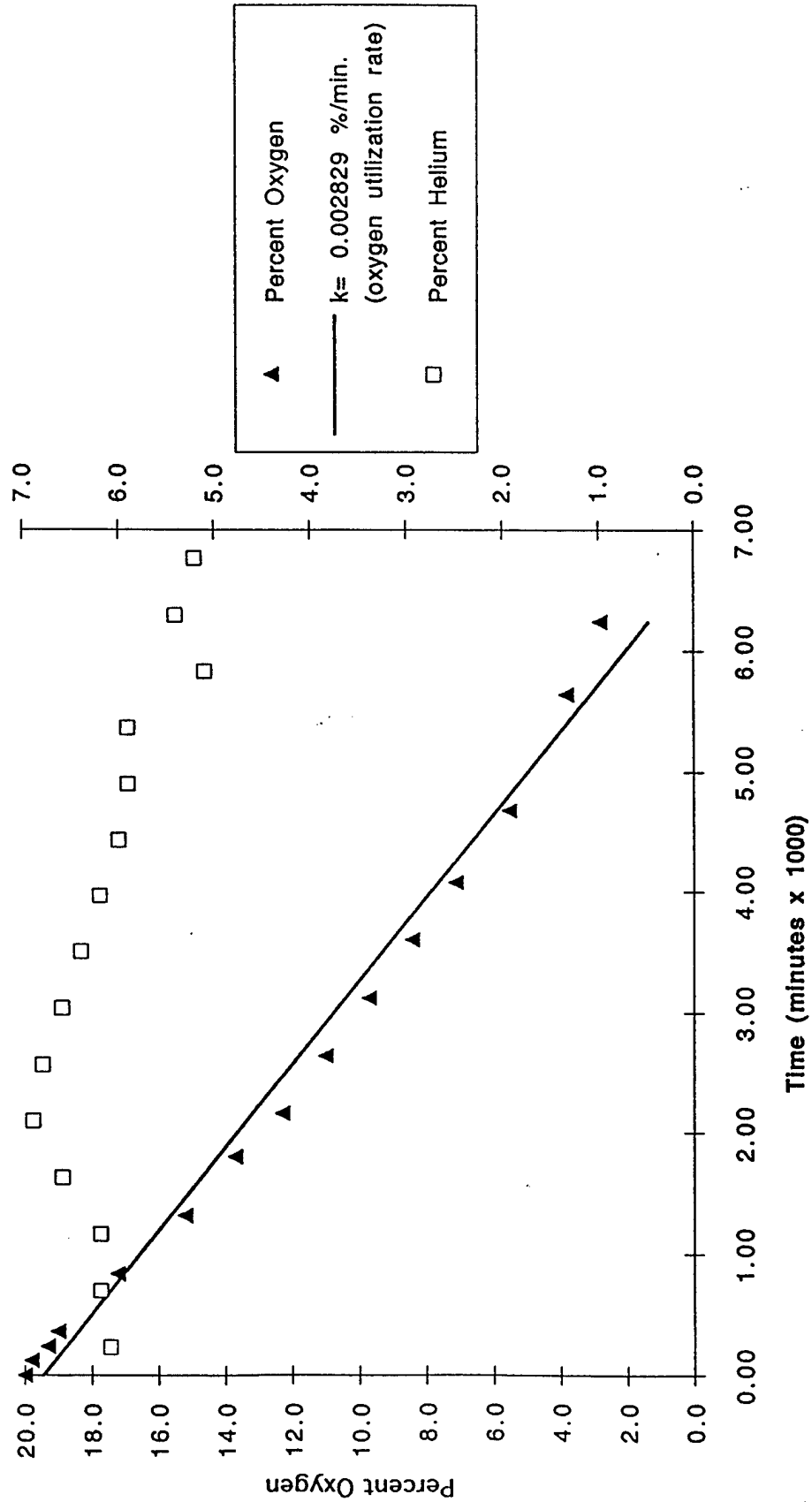

Figure 3.8

**TABLE 3.5**  
**OXYGEN UTILIZATION RATES**  
**FACILITY 44625E**  
**CAPE CANAVERAL AFS, FLORIDA**

Location	O <sub>2</sub> Loss <sup>a/</sup> (%)	Test <sup>b/</sup> Duration	O <sub>2</sub> Utilization <sup>c/</sup> Rate (%/min)
MPA-5.5	19.5	6,240	0.0031
MPB-5.5	16.2	6,240	0.0026
MPC-5.5	17.2	6,240	0.0028

a/ Actual measured oxygen loss.

b/ Elapsed time from beginning of test to time when minimum oxygen concentration was measured.

c/ Values based on best-fit lines (Figures 3.6 through 3.8).

during the three hour air injection test. Because the potential for air emissions is highest during this initial hour of air injection, the long-term emission potential is considered low.

#### 4.0 RECOMMENDATIONS

Initial bioventing tests at these three sites at Cape Canaveral AFS indicate that oxygen has been depleted in the contaminated soils, and that air injection is an effective method of increasing aerobic fuel biodegradation. AFCEE has recommended that air injection begin at the three pilot test areas to determine the long-term radius of oxygen influence and the effect of time, available nutrients, and changing temperatures on fuel biodegradation rates.

Small, 1-horsepower regenerative blowers have been installed at the three sites to continue air injection at a rate of approximately 10 to 20 scfm per well. Following regulatory approval to proceed, the extended 1-year pilot test will begin at each site. Six months after the extended test begins, ES will return to the site to conduct a repeat respiration test. A final respiration test will be conducted, and soil and soil gas samples will be collected from the site to determine the degree of remediation achieved during the first year of *in situ* treatment.

Based on the results of the first year of pilot-scale bioventing, AFCEE will recommend one of three options:

1. Upgrade, if necessary, and continue operation of the bioventing system for full-scale remediation of the site.
2. If final soil sampling indicates significant contaminant removal has occurred, AFCEE may recommend additional sampling to confirm that cleanup criteria have been achieved.
3. If significant difficulties or poor results are encountered during bioventing at this site, AFCEE may recommend removal of the blower system and proper abandonment of the VW and MPs.

#### 5.0 REFERENCES

Hinchee, R.E., S.K. Ong., R.N. Miller, D.C. Downey, and R. Frandt. 1992. *Test Plan and Technical Protocol for a Field Treatability Test for Bioventing*. Prepared for USAF Center for Environmental Excellence. May.

CH<sub>2</sub>M Hill, 1992. Hazwrap, Martin Marietta Phase I Contamination Assessment, Cape Canaveral Air Force Station, Orlando, Florida. April/July.

**APPENDIX A**  
**SYSTEM MAINTENANCE**  
**INSTRUCTIONS**

## **APPENDIX A**

### **SYSTEM MAINTENANCE**

#### **A.1 BLOWER/MOTOR MAINTENANCE**

The blower and motor are relatively maintenance free. There is no lubrication required because the blower and motor have sealed bearings. If a blower system is in need of repair, please contact Steve Archabal at (303) 831-8100.

#### **A.2 FILTER MAINTENANCE**

To avoid damage caused by passing solids through the blower, an air filter has been installed inline before the blower. By design, Gast<sup>®</sup> regenerative blowers are able to ingest small quantities of particles without damage. However, continuous ingestion of solids will damage or imbalance the impellers. The inline air filter will prevent solids from entering the blower, and is rated at 99 percent efficiency to 10 microns.

The filter element is a polyester cloth that can be cleaned and reused, or replaced. The filter should be checked weekly for the first 2 months of operation. The air filter should be cleaned or replaced when the pressure difference across the filter reaches 15 to 20 inches of water. It is the responsibility of Patrick AFB and Cape Canaveral AFS to determine the best schedule for filter cleaning and/or replacement, depending on the results of the initial observations.

The filter can be checked after turning off the blower system. To remove the filter, loosen the clamps, lift the metal top off the air filter, and lift the air filter from the metal housing. When replacing the filter, be careful that the rubber seals remain in place. The filter is manufactured by Solberg Manufacturing, Inc. in Itasca, Illinois. Their phone number is (708) 773-1363. The filters can also be obtained through Fluid Technology, Inc. in Denver, Colorado. The contacts there are Mr. Bob Cook and Mr. Greg Sparks; they can be reached at (303) 233-7400. It is recommended that Cape Canaveral AFS keep at least three spare air filters; one for each site.

#### **A.3 BLOWER PERFORMANCE MONITORING**

To monitor the blower performance, vacuum, pressure, and temperature will be measured. These data will be recorded on the data collection sheets provided. All measurements will be taken at the same time while the system is running.

### A.3.1 Pressure/Vacuum

Record the pressure and vacuum readings directly from the gauges in inches of water. Record the measurements on the data collection sheet provided.

### A.3.2 Temperature

Record the temperature readings directly from the gauges in degrees Fahrenheit. Record the measurements on the data collection sheet provided.

## A.4 MONITORING SCHEDULE

The following monitoring schedule is recommended for this system. During the initial months of operation, more frequent monitoring is recommended to ensure that any start up problems are quickly corrected. Data collection sheets have been provided to record the system data.

<u>Site</u>	<u>Monitoring Item</u>	<u>Monitoring Frequency</u>
Facilities:		
1748 44625D and 44625E Cape Canaveral AFS	Blower vacuum/ pressure and temperature	Weekly



**APPENDIX B**  
**GEOLOGIC BORING LOGS,**  
**TEST DATA, AND CALCULATIONS**

### GEOLOGIC BORING LOG

BORING NO.: <u>CA2-VW</u>	CONTRACTOR: <u>GROUNDWATER PROTECTION</u>	DATE SPUD: <u>12/23/93</u>
CLIENT: <u>AFCEE</u>	RIG TYPE: <u>AUGER</u>	DATE CMPL: <u>12/23/93</u>
JOB NO: <u>722409.26</u>	DRLG METHOD: <u>HSA</u>	ELEVATION: <u>+6 FT - MSL</u>
LOCATION: <u>CAPE CANAVERAL AFS</u>	BORING DIA: <u>12"</u>	TEMP: <u>60-70°F</u>
GEOLOGIST: <u>SRA</u>	DRLG FLUID: <u>NONE</u>	WEATHER: <u>PARTLY CLOUDY</u>

Depth (ft.)	Pro-file	USCS	Geologic Description	Samples		Sample Type	Blow Counts	Remarks TIP = Bkgrnd/Reading(ppm)
				No.	Depth (ft)			
1	[Diagram: Sand with silt]	SP-SM	Sand, f-m, tr. silt, lt-dk gray	VW	0-3.5	G		TVH=2.0 (2')
2								
3								
4								
5	[Diagram: Sand with silt]	SP	Sand, f-c, lt-dk gray, v moist, strong fuel odor		3.5-4.5	G		TVH=250 (4')
6								
7								
8								
9								
10								
11								
12								
13								
14								
15								Total Depth = 8.0 ft.

sl - slight	v - very	NONS - No Odor/ No Stain	f - fine
tr - trace	kt - light	HSA - Hollow Stem Auger	m - medium
sm - some	dk - dark	SSA - Solid Stem Auger	c - coarse
& - and	bf - buff		BH - Bore Hole
@ - at	brn - brown		SAA - Same As Above
w - with	blk - black		M.S.L. - Mean Sea Level

D

SPLIT SPOON SAMPLE

CUTTING SAMPLE

G

GRAB SAMPLE

- - - EST. WATER TABLE

## GEOLOGIC BORING LOG

BORING NO.: CA3-VW	CONTRACTOR: GROUNDWATER PROTECTION	DATE SPUD: 12/23/93
CLIENT: AFCEE	RIG TYPE: AUGER	DATE CMPL: 12/23/93
JOB NO: 722409.26	DRLG METHOD: HSA	ELEVATION: +6 FT - MSL
LOCATION: CAPE CANAVERAL AFS	BORING DIA: 12"	TEMP: 60-70 °F
GEOLOGIST: SRA	DRLG FLUID: NONE	WEATHER: PARTLY CLOUDY

COMMENTS

Depth (ft.)	Pro-file	USCS	Geologic Description	Samples		Sample Type	Blow Counts	Remarks TIP = Bkgnd/Reading(ppm)
				No.	Depth (ft)			
1			Sand, f-m, dk brn stained, fuel odor	VW				TVH=109 (2')
2		SP-SM						
3								
4								
5			Sand, f-c, lt-dk gray, w/sm shell fragments, strong petroleum					TVH=275 (6') -_-_- @ 6.5 ft.
6		SP						
7								
8								
Total Depth = 8.0 ft.								
9								
10								
11								
12								
13								
14								
15								

sl - slight	v - very	NONS - No Odor/	f - fine	<input type="checkbox"/> D	SPLIT SPOON SAMPLE
tr - trace	kt - light	No Stain	m - medium	<input type="checkbox"/>	CUTTING SAMPLE
sm - some	dk - dark	HSA - Hollow Stem	c - coarse	<input type="checkbox"/> G	GRAB SAMPLE
& - and	bf - buff	Auger	BH - Bore Hole		
@ - at	brn - brown	SSA - Solid Stem	SAA - Same As Above		
w - with	blk - black	Auger	M.S.L. - Mean Sea Level		

- - - EST. WATER TABLE

### GEOLOGIC BORING LOG

BORING NO.: CA4-VW	CONTRACTOR: GROUNDWATER PROTECTION	DATE SPUD: 12/23/93
CLIENT: AFCEE	RIG TYPE: AUGER	DATE CMLP: 12/23/93
JOB NO: 722409.26	DRLG METHOD: HSA	ELEVATION: +6 FT - MSL
LOCATION: CAPE CANAVERAL AFS	BORING DIA: 12"	TEMP: 60-70 °F
GEOLOGIST: SRA	DRLG FLUID: NONE	WEATHER: PARTLY CLOUDY

COMMENTS

Depth (ft.)	Pro-file	USCS	Geologic Description	Samples		Sample Type	Blow Counts	Remarks TIP = Bkgnd/Reading(ppm)
				No.	Depth (ft)			
1	[Dotted Pattern]	SP-SM	Sand, f-m, dk brn stained, fuel odor	VW		G		TVH=5.0 (2')
2								
3								
4								
5	[Dashed Pattern]	SP	Sand, f-c, lt-dk gray, w/sm shell fragments, strong fuel odor			G		TVH=101 (6') --- @ 6.5 ft.
6								
7								
8								
9								
10								
11								
12								
13								
14								
15								Total Depth = 8.0 ft.

sl - slight	v - very	NO/NS - No Odor/	f - fine	<input type="checkbox"/> D SPLIT SPOON SAMPLE
tr - trace	kt - light	No Stain	m - medium	<input type="checkbox"/> CUTTING SAMPLE
sm - some	dk - dark	HSA - Hollow Stem	c - coarse	<input type="checkbox"/> GRAB SAMPLE
& - and	bf - buff	Auger	BH - Bore Hole	
@ - at	brn - brown	SSA - Solid Stem	SAA - Same As Above	
w - with	blk - black	Auger	M.S.L. - Mean Sea Level	

- - - EST. WATER TABLE

CAPE CANAVERAL AFS – Facility 1748

Biodegradation Rate Calculations

enter data

calculated data

Formula:  $K_b = K_o \times 1/100\% \times A \times D_o \times C$  Where:

$K_b$  = fuel biodegradation rate

$K_o$  =  $O_2$  utilization rate (%/min.)

A = volume of air/kg soil

$D_o$  =  $O_2$  density = 1340 mg/L

C = Carbon/ $O_2$  ratio for hexane mineralization = 1/3.5

Test Results:

MPA-5.5

$K_o$  = max. observed rate

0.002721

%/min.

w = moisture content

11.8

%

Assume:

Soil properties for mixed grain sand, loose Specify from Table 1.4 (Ref. Foundation Engineering, Peck, Hanson, and Thornburn, John Wiley Press, 1974)

Porosity:

$n = 0.40$

Unit weight (dry):

$\rho_d = 1.59$

Void ratio:

$e = n/(1-n) = 0.67$

Specific gravity:

G = 2.65

Calculate A = Air filled volume ( $V_a$ )/unit wt.

Solving for 1 liter of soil

a)  $V_v = n \times 1 \text{ L}$

$V_v = 0.4$  liters  $V_v$  = void volume

b)  $S_r = Gw/e$

$S_r = 0.47$   $S_r$  = degree of saturation

c)  $V_w = S_r \times V_v$

$V_w = 0.19$  liters  $V_w$  = volume of water

d)  $V_a = V_v - V_w$

$V_a = 0.21$  liters  $V_a$  = volume of air

e) Bulk density =  $\rho_d + (V_w \times \rho_w) = 1.8$  kg/l soil

f)  $A = V_a/\text{Bulk density} = 0.117$  l air/kg soil

$K_b = K_o \times 1/100\% \times A \times D_o \times C \times 525,600 \text{ min/yr} = 640$  mg TPH/year

Monitoring Point	Date	Days Elapsed (frac. days)	Days Elapsed (min. x 1000)	Hrs elapsed (fractional days)	Respiration Test		CO2%	O2%	Hydro-carbon	Helium	Comments	Trend of O2/Time	New x-values	k
					Facility 1748 - Base Cafeteria	Cape Canaveral AFS, FL								
MPA-5.5	01/25/94	0.00	12:00	0.00	0.00	0.00	20.0	0.00	0	4.3	Soil temperature = 68.5 degrees F.	19.928456	0	0.002721
MPA-5.5	01/25/94	0.00	14:00	0.08	0.08	0.12	19.7	0.00	0	4.4	Soil temperature = 71.2 degrees F.	0.9886591	6.96	
MPA-5.5	01/25/94	0.00	16:00	0.17	0.17	0.24	19.5	0.00	0	4.5	Soil temperature = 70.1 degrees F.			
MPA-5.5	01/25/94	0.00	22:00	0.42	0.42	0.60	18.6	0.00	0	4.3	Soil temperature = 71.3 degrees F.			
MPA-5.5	01/26/94	1.00	10:00	-0.08	0.92	1.32	16.5	0.80	0	4.1	Soil temperature = 72.3 degrees F.			
MPA-5.5	01/26/94	1.00	22:00	0.42	1.42	2.04	14.5	1.90	0	3.7	Soil temperature = 71.8 degrees F.			
MPA-5.5	01/27/94	2.00	10:00	-0.08	1.92	2.76	12.4	2.90	0	3.2	Soil temperature = 72.5 degrees F.			
MPA-5.5	01/27/94	2.00	22:00	0.42	2.42	3.48	9.9	4.00	10	2.8	Soil temperature = 72.1 degrees F.			
MPA-5.5	01/28/94	3.00	10:00	-0.08	2.92	4.20	7.3	5.00	20	2.3	Soil temperature = 72.5 degrees F.			
MPA-5.5	01/28/94	3.00	22:00	0.42	3.42	4.92	6.0	6.00	20	2.0	Soil temperature = 72.6 degrees F.			
MPA-5.5	01/29/94	4.00	10:00	-0.08	3.92	5.64	4.8	7.10	20	1.6	Soil temperature = 73.0 degrees F.			
MPA-5.5	01/30/94	5.00	08:00	-0.17	4.83	6.96	2.1	9.20	16	1.4	Soil temperature = 72.8 degrees F.			
MPB-5.5	01/25/94	0.00	12:00	0.00	0.00	0.00	20.0	0.00	0	4.2		20.006308	0	0.002453
MPB-5.5	01/25/94	0.00	14:00	0.08	0.08	0.12	19.8	0.00	0	4.2		2.9349678	6.96	
MPB-5.5	01/25/94	0.00	16:00	0.17	0.17	0.24	19.6	0.00	0	4.4				
MPB-5.5	01/25/94	0.00	22:00	0.42	0.42	0.60	18.8	0.00	0	4.2				
MPB-5.5	01/26/94	1.00	10:00	-0.08	0.92	1.32	16.8	0.80	0	4.2				
MPB-5.5	01/26/94	1.00	22:00	0.42	1.42	2.04	15.0	1.80	0	3.8				
MPB-5.5	01/27/94	2.00	10:00	-0.08	1.92	2.76	12.9	2.70	0	3.4				
MPB-5.5	01/27/94	2.00	22:00	0.42	2.42	3.48	11.2	3.60	0	3.0				
MPB-5.5	01/28/94	3.00	10:00	-0.08	2.92	4.20	9.5	4.50	10	2.6				
MPB-5.5	01/28/94	3.00	22:00	0.42	3.42	4.92	7.7	5.70	10	2.1				
MPB-5.5	01/29/94	4.00	10:00	-0.08	3.92	5.64	6.0	6.80	10	1.8				
MPB-5.5	01/30/94	5.00	08:00	-0.17	4.83	6.96	3.6	8.30	10	1.4				
MPC-5.5	01/25/94	0.00	12:00	0.00	0.00	0.00	20.0	0.00	0	4.2	Soil temperature = 70.3 degrees F.	20.204381	0	0.002746
MPC-5.5	01/25/94	0.00	14:00	0.08	0.08	0.12	19.8	0.00	0	4.1	Soil temperature = 72.3 degrees F.	1.0897	6.96	
MPC-5.5	01/25/94	0.00	16:00	0.17	0.17	0.24	19.6	0.00	0	4.3	Soil temperature = 71.7 degrees F.			
MPC-5.5	01/25/94	0.00	22:00	0.42	0.42	0.60	18.7	0.00	0	4.2	Soil temperature = 72.6 degrees F.			
MPC-5.5	01/26/94	1.00	10:00	-0.08	0.92	1.32	16.5	0.80	0	4.1	Soil temperature = 74.3 degrees F.			
MPC-5.5	01/26/94	1.00	22:00	0.42	1.42	2.04	14.7	2.00	0	3.7	Soil temperature = 73.1 degrees F.			
MPC-5.5	01/27/94	2.00	10:00	-0.08	1.92	2.76	12.7	3.20	0	3.2	Soil temperature = 74.6 degrees F.			
MPC-5.5	01/27/94	2.00	22:00	0.42	2.42	3.48	10.9	4.00	0	2.8	Soil temperature = 73.6 degrees F.			
MPC-5.5	01/28/94	3.00	10:00	-0.08	2.92	4.20	8.8	4.80	10	2.4	Soil temperature = 74.8 degrees F.			
MPC-5.5	01/28/94	3.00	22:00	0.42	3.42	4.92	6.5	5.80	10	2.0	Soil temperature = 75.2 degrees F.			
MPC-5.5	01/29/94	4.00	10:00	-0.08	3.92	5.64	4.3	6.80	10	1.6	Soil temperature = 75.3 degrees F.			
MPC-5.5	01/30/94	5.00	08:00	-0.17	4.83	6.96	1.3	9.00	10	1.2	Soil temperature = 76.5 degrees F.			

Respiration Test  
Oxygen and Helium Concentrations  
Facility 1748 (Base Cafeteria), MPA-5.5  
Cape Canaveral AFS, FL

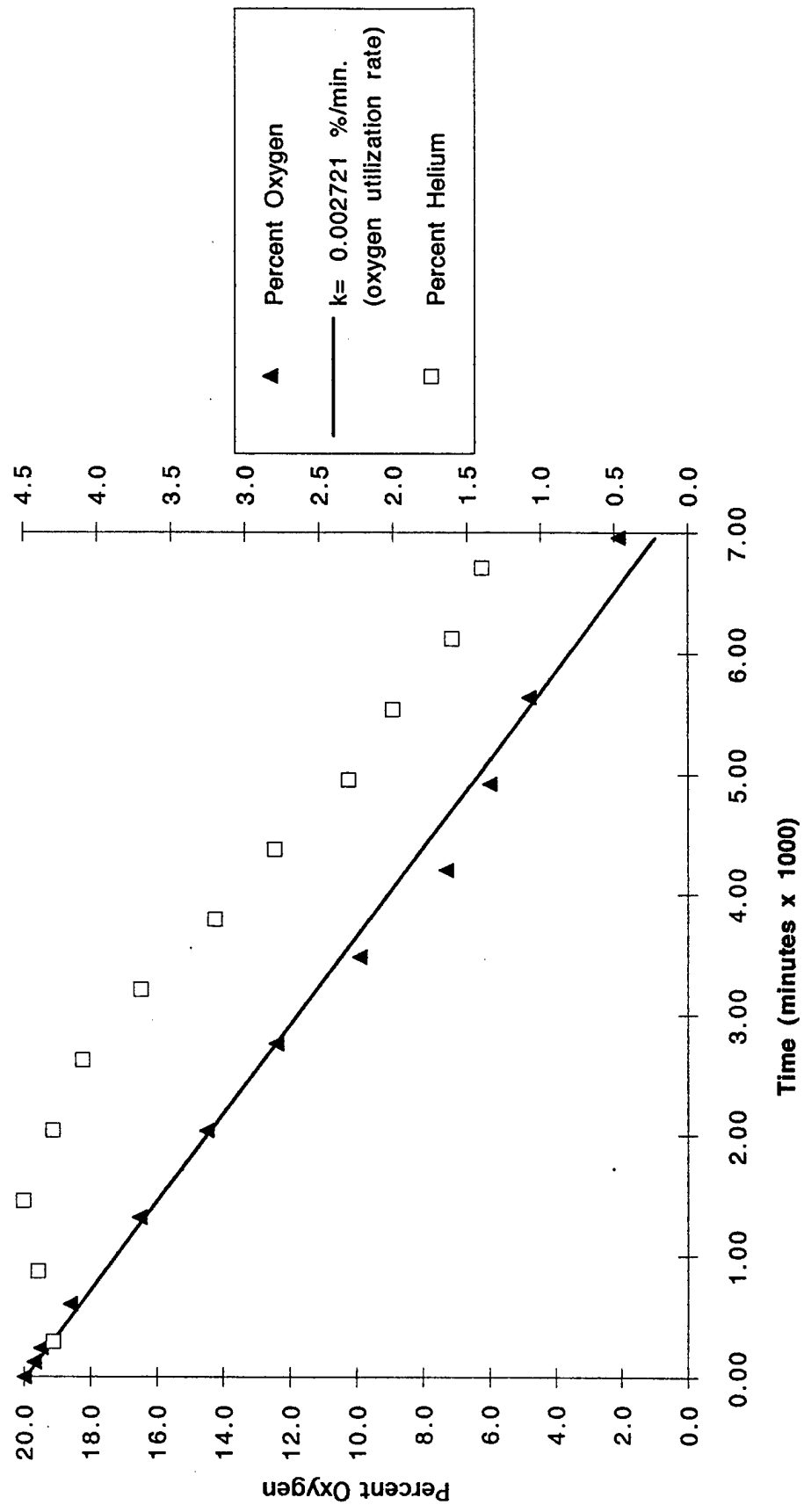

CAPE CANAVERAL AFS – Facility 44625D

Biodegradation Rate Calculations

enter data

calculated data

Formula:  $K_b = K_o \times 1/100\% \times A \times D_o \times C$  Where:

$K_b$  = fuel biodegradation rate

$K_o$  =  $O_2$  utilization rate (%/min.)

A = volume of air/kg soil

$D_o$  =  $O_2$  density = 1340 mg/L

C = Carbon/ $O_2$  ratio for hexane mineralization = 1/3.5

Test Results:   $K_o$  = max. observed rate  %/min.  
 $w$  = moisture content  %

Assume: Soil properties for  Specify from Table 1.4 (Ref. Foundation Engineering, Peck, Hanson, and Thornburn, John Wiley Press, 1974)

Porosity:  $n =$    
 Unit weight (dry):  $\gamma_d =$    
 Void ratio:  $e = n/(1-n) =$    
 Specific gravity:  $G =$

Calculate A = Air filled volume ( $V_a$ )/unit wt.

Solving for 1 liter of soil

a)  $V_v = n \times 1 \text{ L}$   
 $V_v =$   liters  $V_v$  = void volume

b)  $S_r = Gw/e$   
 $S_r =$    $S_r$  = degree of saturation

c)  $V_w = S_r \times V_v$   
 $V_w =$   liters  $V_w$  = volume of water

d)  $V_a = V_v - V_w$   
 $V_a =$   liters  $V_a$  = volume of air

e) Bulk density =  $\gamma_d + (V_w \times \gamma_w) =$   kg/l soil

f)  $A = V_a/\text{Bulk density} =$   l air/kg soil

$K_b = K_o \times 1/100\% \times A \times D_o \times C \times 525,600 \text{ min/yr} =$   mg TPH/year

Respiration Test														
Facility 44625D Generator Shop - Drum Storage Area														
Cape Canaveral AFS, FL														
Monitoring Point	Date	Days Elapsed (frac. days)	Time	Hrs elapsed (fractional days)	Days Elapsed	Elapsed Time (min. x 1000)	O2%	CO2%	Hydro-carbon	Helium	Comments	Trend of O2/Time	New x-values	k
MPA-5.5	01/19/94	0.00	10:00	0.00	0.00	0.00	20.0	0.00	0	5.9	Soil temperature = 64.2 degrees F.	19.924714	0	0.006728
MPA-5.5	01/19/94	0.00	12:00	0.08	0.08	0.12	19.5	0.00	0	6.0	Soil temperature = 67.4 degrees F.	5.392144	2.16	
MPA-5.5	01/19/94	0.00	14:00	0.17	0.17	0.24	18.7	0.20	0	5.9	Soil temperature = 69.2 degrees F.			
MPA-5.5	01/19/94	0.00	16:00	0.25	0.25	0.36	17.7	0.40	0	6.0	Soil temperature = 70.3 degrees F.			
MPA-5.5	01/19/94	0.00	22:00	0.50	0.50	0.72	14.5	0.60	0	6.0	Soil temperature = 70.1 degrees F.			
MPA-5.5	01/20/94	1.00	06:00	-0.17	0.83	1.20	10.9	1.60	0	6.0	Soil temperature = 70.5 degrees F.			
MPA-5.5	01/20/94	1.00	14:00	0.17	1.17	1.68	8.0	3.10	0	5.8	Soil temperature = 72.5 degrees F.			
MPA-5.5	01/20/94	1.00	22:00	0.50	1.50	2.16	6.5	4.00	0	5.6	Soil temperature = 70.6 degrees F.			
MPA-5.5	01/21/94	2.00	06:00	-0.17	1.83	2.64	5.0	4.80	0	5.4	Soil temperature = 71.6 degrees F.			
MPA-5.5	01/21/94	2.00	16:00	0.25	2.25	3.24	2.9	5.30	28	4.9	Soil temperature = 72.5 degrees F.			
MPA-5.5	01/22/94	3.00	08:00	-0.08	2.92	4.20	0.3	7.00	60	4.8	Soil temperature = 70.8 degrees F.			
MPA-5.5	01/22/94	3.00	18:00	0.33	3.33	4.80	0.0	8.00	68	4.8	Soil temperature = 72.4 degrees F.			
MPB-5.5	01/19/94	0.00	10:00	0.00	0.00	0.00	20.0	0.00	0	6.0		19.961922	0	0.004323
MPB-5.5	01/19/94	0.00	12:00	0.08	0.08	0.12	19.7	0.00	0	6.0		-0.7893277	4.8	
MPB-5.5	01/19/94	0.00	14:00	0.17	0.17	0.24	19.1	0.10	0	5.8				
MPB-5.5	01/19/94	0.00	16:00	0.25	0.25	0.36	18.8	0.20	0	5.9				
MPB-5.5	01/19/94	0.00	22:00	0.50	0.50	0.72	17.0	0.40	0	6.0				
MPB-5.5	01/20/94	1.00	06:00	-0.17	0.83	1.20	14.5	0.50	0	5.8				
MPB-5.5	01/20/94	1.00	14:00	0.17	1.17	1.68	12.3	0.90	0	5.8				
MPB-5.5	01/20/94	1.00	22:00	0.50	1.50	2.16	10.3	1.50	0	5.5				
MPB-5.5	01/21/94	2.00	06:00	-0.17	1.83	2.64	8.2	2.20	0	5.2				
MPB-5.5	01/21/94	2.00	16:00	0.25	2.25	3.24	5.5	2.90	10	4.5				
MPB-5.5	01/22/94	3.00	08:00	-0.08	2.92	4.20	1.8	4.50	36	4.3				
MPB-5.5	01/22/94	3.00	18:00	0.33	3.33	4.80	0.0	5.50	48	4.2				
MPC-5.5	01/19/94	0.00	10:00	0.00	0.00	0.00	19.9	0.00	0	5.9	Soil temperature = 64.7 degrees F.	18.625286	0	0.008272
MPC-5.5	01/19/94	0.00	12:00	0.08	0.08	0.12	18.3	0.40	0	5.9	Soil temperature = 67.4 degrees F.	0.757856	2.16	
MPC-5.5	01/19/94	0.00	14:00	0.17	0.17	0.24	16.8	0.60	0	5.8	Soil temperature = 70.1 degrees F.			
MPC-5.5	01/19/94	0.00	16:00	0.25	0.25	0.36	15.2	0.80	0	5.7	Soil temperature = 71.0 degrees F.			
MPC-5.5	01/19/94	0.00	22:00	0.50	0.50	0.72	11.3	1.60	0	5.0	Soil temperature = 70.8 degrees F.			
MPC-5.5	01/20/94	1.00	06:00	-0.17	0.83	1.20	7.2	2.60	0	3.9	Soil temperature = 71.0 degrees F.			
MPC-5.5	01/20/94	1.00	14:00	0.17	1.17	1.68	4.3	4.10	15	3.1	Soil temperature = 72.8 degrees F.			
MPC-5.5	01/20/94	1.00	22:00	0.50	1.50	2.16	2.4	5.70	40	2.5	Soil temperature = 70.8 degrees F.			
MPC-5.5	01/21/94	2.00	06:00	-0.17	1.83	2.64	0.5	7.20	60	1.9	Soil temperature = 71.8 degrees F.			
MPC-5.5	01/21/94	2.00	16:00	0.25	2.25	3.24	0.0	9.00	40	1.2	Soil temperature = 72.6 degrees F.			
MPC-5.5	01/22/94	3.00	08:00	-0.08	2.92	4.20	0.0	10.70	50	1.0	Soil temperature = 71.2 degrees F.			
MPC-5.5	01/22/94	3.00	18:00	0.33	3.33	4.80	0.0	11.60	60	0.8	Soil temperature = 72.6 degrees F.			

Respiration Test  
Oxygen and Helium Concentrations  
Facility 44625D (Generator Shop - Drum Storage Area), MPA-5.5  
Cape Canaveral AFS, FL

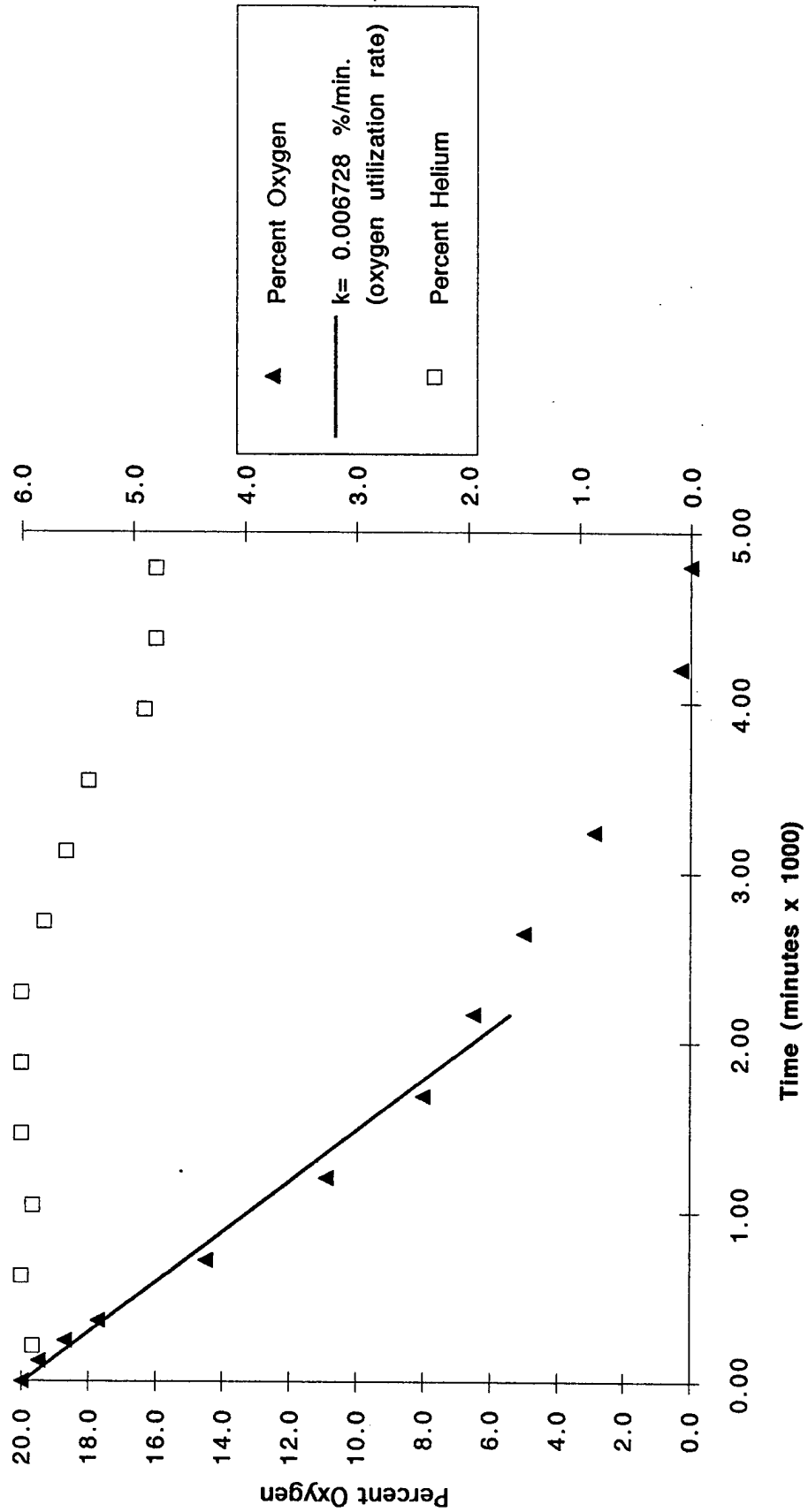

CAPE CANAVERAL AFS – Facility 44625E

Biodegradation Rate Calculations

enter data

calculated data

Formula:  $K_b = K_o \times 1/100\% \times A \times D_o \times C$  Where:

$K_b$  = fuel biodegradation rate

$K_o$  =  $O_2$  utilization rate (%/min.)

A = volume of air/kg soil

$D_o$  =  $O_2$  density = 1340 mg/L

C = Carbon/ $O_2$  ratio for hexane mineralization = 1/3.5

Test Results:

MPB-5.5

$K_o$  = max. observed rate

0.002629

%/min.

w = moisture content

6.2

%

Assume:

Soil properties for mixed grain sand, loose Specify from Table 1.4 (Ref. Foundation Engineering, Peck, Hanson, and Thornburn, John Wiley Press, 1974)

Porosity:

$n = 0.40$

Unit weight (dry):

$\gamma_d = 1.59$

Void ratio:

$e = n/(1-n) = 0.67$

Specific gravity:

G = 2.65

Calculate A = Air filled volume ( $V_a$ )/unit wt.

Solving for 1 liter of soil

a)  $V_v = n \times 1 \text{ L}$

$V_v = 0.4$  liters  $V_v$  = void volume

b)  $S_r = Gw/e$

$S_r = 0.25$   $S_r$  = degree of saturation

c)  $V_w = S_r \times V_v$

$V_w = 0.1$  liters  $V_w$  = volume of water

d)  $V_a = V_v - V_w$

$V_a = 0.30$  liters  $V_a$  = volume of air

e) Bulk density =  $\gamma_d + (V_w \times \gamma_w) = 1.7$  kg/l soil

f)  $A = V_a / \text{Bulk density} = 0.176$  l air/kg soil

$K_b = K_o \times 1/100\% \times A \times D_o \times C \times 525,600 \text{ min/yr} = 930$  mg TPH/year

**Respiration Test**  
**Facility 44625E Generator Shop - Maintenance Area**  
**Cape Canaveral AFS, FL**

Monitoring Point	Date	Days Elapsed (frac. days)	Days Elapsed (min. x 1000)	Hrs elapsed (fractional days)	Days Elapsed	Elapsed Time			Total Hydro-carbon	Helium	Comments	Trend of O2/Time	New x-values	k
						O2%	CO2%	CO2%						
MPA-5.5	01/18/94	0.00	11:00	0.00	0.00	0.00	20.0	0.00	0	6.3	Soil temperature = 64.5 degrees F.	19.783614	0	0.003148
MPA-5.5	01/18/94	0.00	13:00	0.08	0.08	0.12	19.8	0.00	0	6.2	Soil temperature = 67.8 degrees F.	0.1431622	6.24	
MPA-5.5	01/18/94	0.00	15:00	0.17	0.17	0.24	19.2	0.10	0	6.3	Soil temperature = 68.7 degrees F.			
MPA-5.5	01/18/94	0.00	17:00	0.25	0.25	0.36	18.9	0.10	0	6.5	Soil temperature = 69.8 degrees F.			
MPA-5.5	01/19/94	1.00	01:00	-0.42	0.58	0.84	17.1	0.50	0	6.8	Soil temperature = 69.1 degrees F.			
MPA-5.5	01/19/94	1.00	09:00	-0.08	0.92	1.32	15.2	0.90	0	6.5	Soil temperature = 68.6 degrees F.			
MPA-5.5	01/19/94	1.00	17:00	0.25	1.25	1.80	13.9	1.30	0	6.1	Soil temperature = 70.5 degrees F.			
MPA-5.5	01/19/94	1.00	23:00	0.50	1.50	2.16	12.8	1.90	0	5.5	Soil temperature = 70.7 degrees F.			
MPA-5.5	01/20/94	2.00	07:00	-0.17	1.83	2.64	11.0	2.50	0	5.3	Soil temperature = 69.6 degrees F.			
MPA-5.5	01/20/94	2.00	15:00	0.17	2.17	3.12	9.8	3.30	0	5.0	Soil temperature = 70.5 degrees F.			
MPA-5.5	01/20/94	2.00	23:00	0.50	2.50	3.60	8.4	4.10	0	4.8	Soil temperature = 70.0 degrees F.			
MPA-5.5	01/21/94	3.00	07:00	-0.17	2.83	4.08	7.0	4.90	0	4.6	Soil temperature = 69.8 degrees F.			
MPA-5.5	01/21/94	3.00	17:00	0.25	3.25	4.68	5.0	5.60	10	3.9	Soil temperature = 70.7 degrees F.			
MPA-5.5	01/22/94	4.00	09:00	-0.08	3.92	5.64	2.2	7.30	16	3.9	Soil temperature = 69.6 degrees F.			
MPA-5.5	01/22/94	4.00	19:00	0.33	4.33	6.24	0.5	8.20	20	3.8	Soil temperature = 71.2 degrees F.			
MPB-5.5	01/18/94	0.00	11:00	0.00	0.00	0.00	20.0	0.00	0	6.2		19.576106	0	0.002629
MPB-5.5	01/18/94	0.00	13:00	0.08	0.08	0.12	19.8	0.00	0	6.2		3.1729708	6.24	
MPB-5.5	01/18/94	0.00	15:00	0.17	0.17	0.24	19.2	0.10	0	6.3				
MPB-5.5	01/18/94	0.00	17:00	0.25	0.25	0.36	19.0	0.10	0	6.6				
MPB-5.5	01/19/94	1.00	01:00	-0.42	0.58	0.84	17.4	0.50	0	6.9				
MPB-5.5	01/19/94	1.00	09:00	-0.08	0.92	1.32	15.8	0.70	0	6.7				
MPB-5.5	01/19/94	1.00	17:00	0.25	1.25	1.80	14.3	0.80	0	6.7				
MPB-5.5	01/19/94	1.00	23:00	0.50	1.50	2.16	13.3	0.90	0	6.3				
MPB-5.5	01/20/94	2.00	07:00	-0.17	1.83	2.64	12.1	1.00	0	6.4				
MPB-5.5	01/20/94	2.00	15:00	0.17	2.17	3.12	11.0	1.50	0	6.3				
MPB-5.5	01/20/94	2.00	23:00	0.50	2.50	3.60	9.9	2.00	0	6.1				
MPB-5.5	01/21/94	3.00	07:00	-0.17	2.83	4.08	8.9	2.50	0	5.9				
MPB-5.5	01/21/94	3.00	17:00	0.25	3.25	4.68	7.2	2.80	10	5.4				
MPB-5.5	01/22/94	4.00	09:00	-0.08	3.92	5.64	5.1	3.80	5	5.4				
MPB-5.5	01/22/94	4.00	19:00	0.33	4.33	6.24	3.8	4.40	10	5.3				
MPC-5.5	01/18/94	0.00	11:00	0.00	0.00	0.00	20.0	0.00	0	6.1	Soil temperature = 66.2 degrees F.	19.439069	0	0.002899
MPC-5.5	01/18/94	0.00	13:00	0.08	0.08	0.12	19.8	0.00	0	6.2	Soil temperature = 68.1 degrees F.	1.3515318	6.24	
MPC-5.5	01/18/94	0.00	15:00	0.17	0.17	0.24	19.3	0.10	0	6.2	Soil temperature = 68.9 degrees F.			
MPC-5.5	01/18/94	0.00	17:00	0.25	0.25	0.36	19.0	0.10	0	6.6	Soil temperature = 69.8 degrees F.			
MPC-5.5	01/19/94	1.00	01:00	-0.42	0.58	0.84	17.2	0.50	0	6.9	Soil temperature = 69.1 degrees F.			
MPC-5.5	01/19/94	1.00	09:00	-0.08	0.92	1.32	15.2	0.70	0	6.8	Soil temperature = 68.6 degrees F.			
MPC-5.5	01/19/94	1.00	17:00	0.25	1.25	1.80	13.7	0.90	0	6.6	Soil temperature = 70.8 degrees F.			
MPC-5.5	01/19/94	1.00	23:00	0.50	1.50	2.16	12.3	1.00	0	6.4	Soil temperature = 70.8 degrees F.			
MPC-5.5	01/20/94	2.00	07:00	-0.17	1.83	2.64	11.0	1.30	0	6.2	Soil temperature = 69.6 degrees F.			
MPC-5.5	01/20/94	2.00	15:00	0.17	2.17	3.12	9.7	2.00	0	6.0	Soil temperature = 70.7 degrees F.			
MPC-5.5	01/20/94	2.00	23:00	0.50	2.50	3.60	8.4	2.50	0	5.9	Soil temperature = 70.3 degrees F.			
MPC-5.5	01/21/94	3.00	07:00	-0.17	2.83	4.08	7.1	3.00	0	5.9	Soil temperature = 70.1 degrees F.			
MPC-5.5	01/21/94	3.00	17:00	0.25	3.25	4.68	5.5	3.30	8	5.1	Soil temperature = 70.5 degrees F.			
MPC-5.5	01/22/94	4.00	09:00	-0.08	3.92	5.64	3.8	4.20	5	5.4	Soil temperature = 70.2 degrees F.			
MPC-5.5	01/22/94	4.00	19:00	0.33	4.33	6.24	2.8	4.70	10	5.2	Soil temperature = 70.8 degrees F.			

Respiration Test  
Oxygen and Helium Concentrations  
Facility 44625E (Generator Shop - Maintenance Area), MPA-5.5  
Cape Canaveral AFS, FL

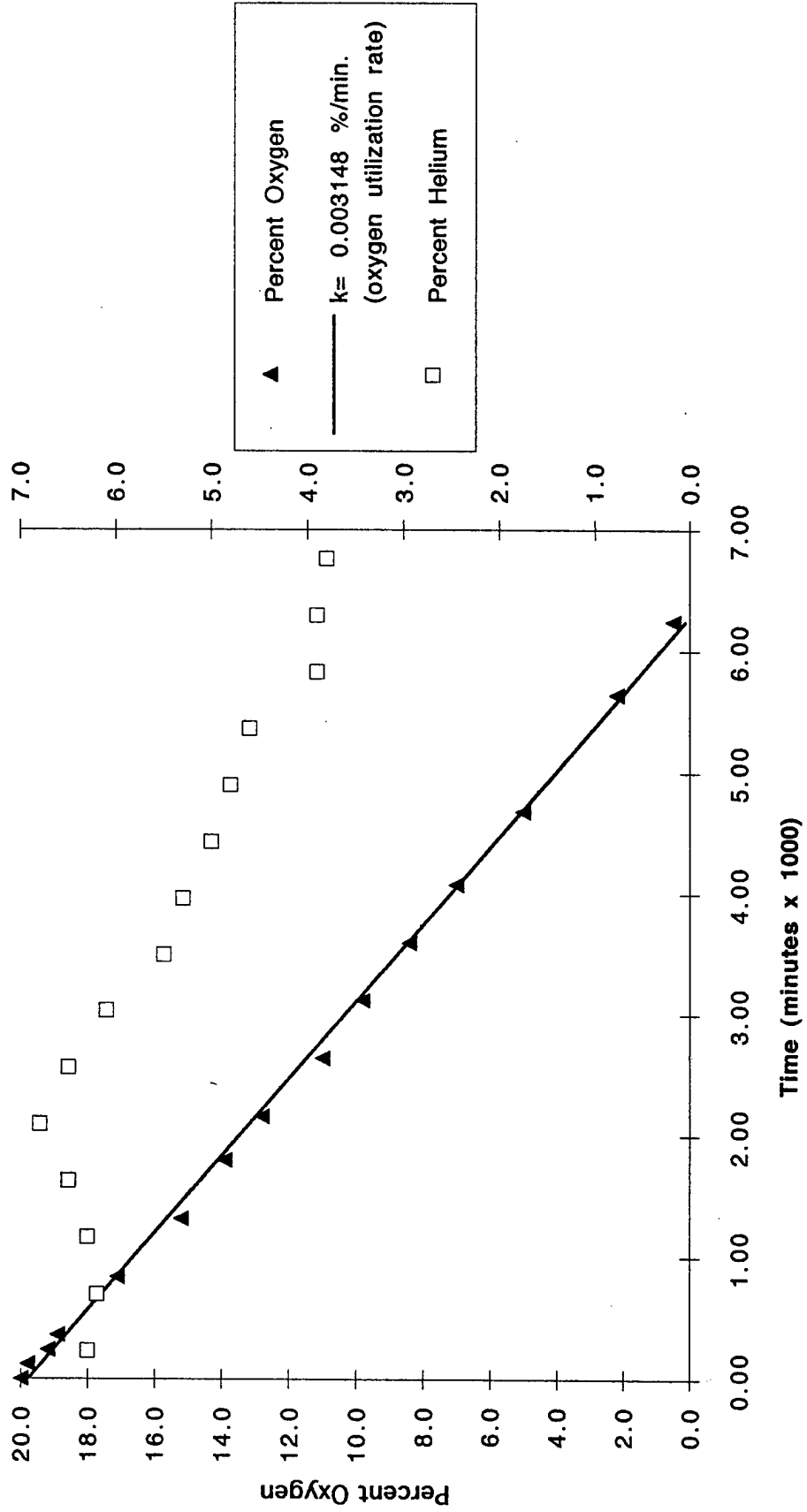

**APPENDIX C**  
**CHAIN OF CUSTODY FORMS**



Lab Job No. \_\_\_\_\_  
Page 1 of 1

Shipment No.: \_\_\_\_\_  
Ship Method: FED EX  
Ship Date: 1/3/94  
Airbill No.: 8645062436

PACE, Incorporated  
Southern California Regional Office  
5702 Bolsa Avenue  
Huntington Beach, CA 92649  
TEL: (714) 892-2565  
FAX: (714) 890-4032

PACE, Incorporated  
Minnesota Regional Office  
1710 Douglas Drive North  
Minneapolis, MN 55422  
TEL: (612) 544-5543  
FAX: (612) 525-3377

Client: AFCEE Bioventing Pilot Test  
Address: ENGINEERING-SCIENCE, INC.  
1700 BROADWAY, SUITE 900  
DENVER, CO. 80210  
TEL: (303) 831-8100  
FAX: \_\_\_\_\_  
Contract/DO No.: \_\_\_\_\_  
Project Name/Number: DE268.26.08  
Project Manager: DOUG DOWNEY - ES  
DENVER, CO.  
SITE MANAGER: STEVE ARCHABAL

Number of Containers	Analysis Required										Remarks	FACILITY #
	SWB020 (BTEX)	E418.1 (TRPH)	E351.2 (TKN)	E365.3 (PHOS.)	UCM (GLASS)	SW9045 (PH)	A403 (ALKA)	SW7380 (IRON)	SW846 (MOIST.)			
3	X	X	X	X	X	X	X	X	X	X		1748
3	X	X	X	X	X	X	X	X	X	X		11
3	X	X	X	X	X	X	X	X	X	X		11
3	X	X	X	X	X	X	X	X	X	X		44625D
3	X	X	X	X	X	X	X	X	X	X		11
3	X	X	X	X	X	X	X	X	X	X		11
3	X	X	X	X	X	X	X	X	X	X		44625E
3	X	X	X	X	X	X	X	X	X	X		11
3	X	X	X	X	X	X	X	X	X	X		11

Cooler Number	Field Sample Number	SBD	SED	Log Date	Log Time	Sample Matrix	Type/Size of Container	Preservation	
								Temp	Chemical
	CA2-VW-5.5	5.0	5.5	12/30/93	1000	SO	GLASS/8OZ.	4°C	NONE
	CA2-MPA-5.5	5.0	5.5	12/30/93	1030	SO	GLASS/8OZ.	4°C	NONE
	CA2-MPB-5.5	5.0	5.5	12/30/93	1100	SO	GLASS/8 OZ.	4°C	NONE
	CA3-VW-5.5	5.0	5.5	12/30/93	1300	SO	GLASS/8 OZ.	4°C	NONE
	CA3-MPA-5.5	5.0	5.5	12/30/93	1330	SO	GLASS/8 OZ.	4°C	NONE
	CA3-MPB-5.5	5.0	5.5	12/30/93	1400	SO	GLASS/8 OZ.	4°C	NONE
	CA4-VW-5.5	5.0	5.5	12/30/93	1500	SO	GLASS/8 OZ.	4°C	NONE
	CA4-MPA-5.5	5.0	5.5	12/30/93	1530	SO	GLASS/8 OZ.	4°C	NONE
	CA4-MPB-5.5	5.0	5.5	12/30/93	1600	SO	GLASS/8 OZ.	4°C	NONE

Sampler's Signature: Steven R. Archabal

Relinquished by: \_\_\_\_\_  
Signature: \_\_\_\_\_  
Printed: STEVEN R. ARCHABAL  
Company: ENGINEERING-SCIENCE, INC.  
Reason: SHIP TO TAB

Received by: \_\_\_\_\_  
Signature: \_\_\_\_\_  
Printed: \_\_\_\_\_  
Company: FED EX

Date: \_\_\_\_\_  
Time: \_\_\_\_\_

Relinquished by: \_\_\_\_\_  
Signature: \_\_\_\_\_  
Printed: \_\_\_\_\_  
Company: \_\_\_\_\_  
Reason: \_\_\_\_\_

Date: \_\_\_\_\_  
Time: \_\_\_\_\_

Received by: \_\_\_\_\_  
Signature: \_\_\_\_\_  
Printed: \_\_\_\_\_  
Company: \_\_\_\_\_

Date: \_\_\_\_\_  
Time: \_\_\_\_\_

Comments: PLEASE REPORT RESULTS PER FACILITY #.  
REC @ 6°C G  
1-1-94

- LEGEND
- SBD: Sample Beginning Depth
  - SED: Sample Ending Depth
  - Log Date: Collection Date
  - Log Time: Collection Time
  - Sample Matrix:
  - SO - Soil
  - SE - Sediment
  - WG - Groundwater
  - WS - Surface Water
  - DC - Drill Cuttings
  - AG - Soil Gas
  - WQ - Field Quality Control
  - Sample (TB, EB, AB)







135473

**CHAIN-OF-CUSTODY RECORD**  
Analytical Request

Report To: THERESA LEAHY  
 Bill To: \_\_\_\_\_  
 P.O. # / Billing Reference 75-3317  
 Project Name / No. 740104.S02

Pace Client No. \_\_\_\_\_  
 Pace Project Manager \_\_\_\_\_  
 Pace Project No. \_\_\_\_\_  
 \*Requested Due Date: NORMAL

Client PACE  
 Address \_\_\_\_\_  
 Phone \_\_\_\_\_

ITEM NO.	SAMPLE DESCRIPTION	TIME	MATRIX	PACENO.	NO. OF CONTAINERS	PRESERVATIVES				ANALYSES REQUEST	REMARKS
						UNPRESERVED	H <sub>2</sub> SO <sub>4</sub>	HNO <sub>3</sub>	VOA		
1	CA4-VW-S.S	12-30-93	Soil		1	X	X	X		TLN PHOS SOIL CLASS	AFCEE - 01
2	CA4-MPA-S.S		"		1	X	X	X			- 07
3	CA4-MPB-S.S		"		1	X	X	X			- 03
4											
5											
6											
7											
8											

COOLER NOS	BAILERS	SHIPMENT METHOD	RETURNED DATE	ITEM NUMBER	RELINQUISHED BY	AFFILIATION	ACCEPTED BY	AFFILIATION	DATE	TIME
					<i>A. W.</i>	PACE	<i>SJM</i>	VIA FED EX	1-4	1600
						VIA FED EX			1/5	16:00
Additional Comments										
000058										

SEE REVERSE SIDE FOR INSTRUCTIONS

