

**US Army Corps
of Engineers®**
Engineer Research and
Development Center

New McAlpine Lock Filling and Emptying System, Ohio River, Kentucky

Hydraulic Model Investigation

John E. Hite, Jr.

September 2000

DTIC QUALITY INSPECTED 4
20001211 117

The contents of this report are not to be used for advertising, publication, or promotional purposes. Citation of trade names does not constitute an official endorsement or approval of the use of such commercial products.

The findings of this report are not to be construed as an official Department of the Army position, unless so designated by other authorized documents.



PRINTED ON RECYCLED PAPER

ERDC/CHL TR-00-24
September 2000

New McAlpine Lock Filling and Emptying System, Ohio River, Kentucky

Hydraulic Model Investigation

by John E. Hite, Jr.

Coastal and Hydraulics Laboratory
U.S. Army Engineer Research and Development Center
3909 Halls Ferry Road
Vicksburg, MS 39180-6199

Final report

Approved for public release; distribution is unlimited

Prepared for U.S. Army Engineer District, Louisville
P.O. Box 59
Louisville, KY 40201-0059

Engineer Research and Development Center Cataloging-in-Publication Data

Hite, John E.

New McAlpine Lock filling and emptying system, Ohio River, Kentucky : hydraulic model investigation / by John E. Hite, Jr. ; prepared for U.S. Army Engineer District, Louisville.

112 p. : ill. ; 28 cm. -- (ERDC/CHL ; TR-00-24)

Includes bibliographic references.

1. Locks (Hydraulic engineering) -- Kentucky -- Models. 2. McAlpine Locks and Dam (Ky.) -- Models. I. United States. Army. Corps of Engineers. Louisville District. II. Engineer Research and Development Center (U.S.) III. Coastal and Hydraulics Laboratory (U.S.) IV. Series: ERDC/CHL TR ; 00-24.

TA7 E8 no.ERDC/CHL TR-00-24

Contents

Preface	v
1—Introduction	1
Background	1
Prototype	1
Purpose and Scope.....	3
2—Physical Model	5
Description	5
Appurtenances and Instrumentation	8
Similitude Considerations.....	9
Kinematic similitude	9
Dynamic similitude	10
Similitude for lock models	10
Experimental Procedures.....	12
3—Model Experiments and Results	13
Type 1 Design	13
Initial experiments.....	13
Hawser forces, 2-min valve operation	15
Hawser forces, 4-min valve operation	15
Hawser forces, 8-min valve operation	16
Intake Vortex Experiments.....	16
Type 2 Chamber Design.....	17
Type 3 Chamber Design.....	18
Type 4 Chamber Design.....	18
Type 5 Chamber Design.....	18
Type 6 and 7 Chamber Designs.....	18
Type 8 Chamber Design.....	19
Type 9 Chamber Design.....	19
Type 10 Chamber Design.....	19
Type 11 Chamber Design.....	20
Type 12 Chamber Design.....	20
Type 13 Chamber Design.....	20
Varying Valve Speed Experiments.....	21
Lock Emptying Operations.....	21
Pressure Measurements	22
Additional Vortex Experiments.....	24
Type 2 roof extensions	24

Type 3 roof extension.....	24
Outlet Manifold Experiments	24
Single Valve Experiments	25
9.14 m (30 ft) Lift Experiments.....	25
4—Summary and Conclusions	27
References	30
Tables 1-18	
Photos 1-6	
Plates 1-52	
SF 298	

List of Figures

Figure 1. Location map.....	2
Figure 2. Dry bed view of Type 1 (original) design looking downstream, scale model of the McAlpine Lock.....	6
Figure 3. Hawser-pull (force links) measuring device	9
Figure 4. Approximate periods of oscillation.....	14

Preface

The model investigation reported herein was authorized by Headquarters, U.S. Army Corps of Engineers (HQUSACE) at the request U.S. Army Engineer District, Louisville (LRL) on 29 January 1998. The model experiments were performed during the period June 1998 to January 1999 by personnel of the Coastal and Hydraulics Laboratory (CHL) of the U.S. Army Engineer Research and Development Center (ERDC) under the general supervision of Drs. James R. Houston, former Director of CHL; and P. G. Combs, former Chief of the Rivers and Structures Division, CHL.

The experimental program was led by Mr. J. E. Myrick under the supervision of Dr. J. E. Hite, Jr., Leader, Locks and Conduits Group and in cooperation with by Dr. R. L. Stockstill, Locks and Conduits Group. Model construction was completed by Messrs. M. A. Simmons and J. A. Lyons of the Model Shop, Department of Public Works (DPW), ERDC, and the ported manifolds were constructed by Mr. J. Schultz, DPW. Data acquisition and remote-control equipment were installed and maintained by Mr. S. W. Guy, Information Technology Laboratory (ITL), ERDC. Data acquisition software was developed by Dr. B. W. McCleave, ITL. The report was written by Dr. Hite and was peer reviewed by Dr. Stockstill.

During the course of the model study, Messrs. Larry Curry, Ron Holmberg, George McCollom, Larry Dalton, and Ms. Kathy Feger of LRL visited ERDC to observe model operation, review experiment results, and discuss model results.

At the time of publication of this report, Dr. James R. Houston was Director of ERDC, and COL James S. Weller, EN, was Commander.

The contents of this report are not to be used for advertising, publication, or promotional purposes. Citation of trade names does not constitute an official endorsement or approval for the use of such commercial products.

1 Introduction

Background

The U.S. Army Engineer District, Louisville (LRL), is planning navigation improvements at McAlpine Locks and Dam on the Ohio River. These improvements include construction of a 365.8-m- (1,200-ft-) long chamber south of the existing lock chamber. In the mid 1990s, a number of U.S. Army Corps of Engineers Districts including the Louisville District, the Huntington District (LRH), the Pittsburgh District (LRP), and the St. Louis District (MVS), formed an innovative lock design team, pooled their resources and initiated a study with the U.S. Army Engineer Research and Development Center (ERDC) to find innovative methods to reduce construction and operation and maintenance costs of navigation structures. This team agreed that large savings in lock wall construction costs could be realized if the lock filling and emptying culverts were placed inside the lock chamber rather than in the lock walls. This filling and emptying system was named an In-Chamber Longitudinal Culvert Filling and Emptying System (ILCS). The navigation improvements planned for the McAlpine project provided a desirable site to investigate the ILCS.

Prototype

The existing McAlpine Locks and Dam project is located on the Kentucky side of the Ohio River at Louisville, KY, generally extending from mile 608 to mile 604 (Figure 1). The project consists of a gated spillway, a fixed weir, a powerhouse, one 33.53-m by 182.88-m (110-ft by 600-ft) auxiliary lock, one 17.07-m by 109.73-m (56-ft by 360-ft) lock (nonoperational), and one 33.53-m by 365.76-m (110-ft by 1,200-ft) main lock. The existing main lock is operating at capacity and an additional 365.76-m-long by 33.53-m-wide (1,200-ft-long by 110-ft-wide) lock is necessary to satisfy future capacity projections. The new lock will replace the existing 182.88-m (600-ft) lock with the upstream pintles (cross stream axis of the miter gates) located at the same station as those of the existing 365.76-m (1,200-ft) lock. The normal upper pool elevation¹ for the McAlpine project is 420.0 and the normal lower pool elevation is 383.0 resulting in a lift of 11.28 m (37 ft) which is characterized as a medium-lift lock.

¹ All elevations (el) cited herein are in feet referred to the Ohio River Datum. (To convert feet to meters, multiply number of feet by 0.3048).

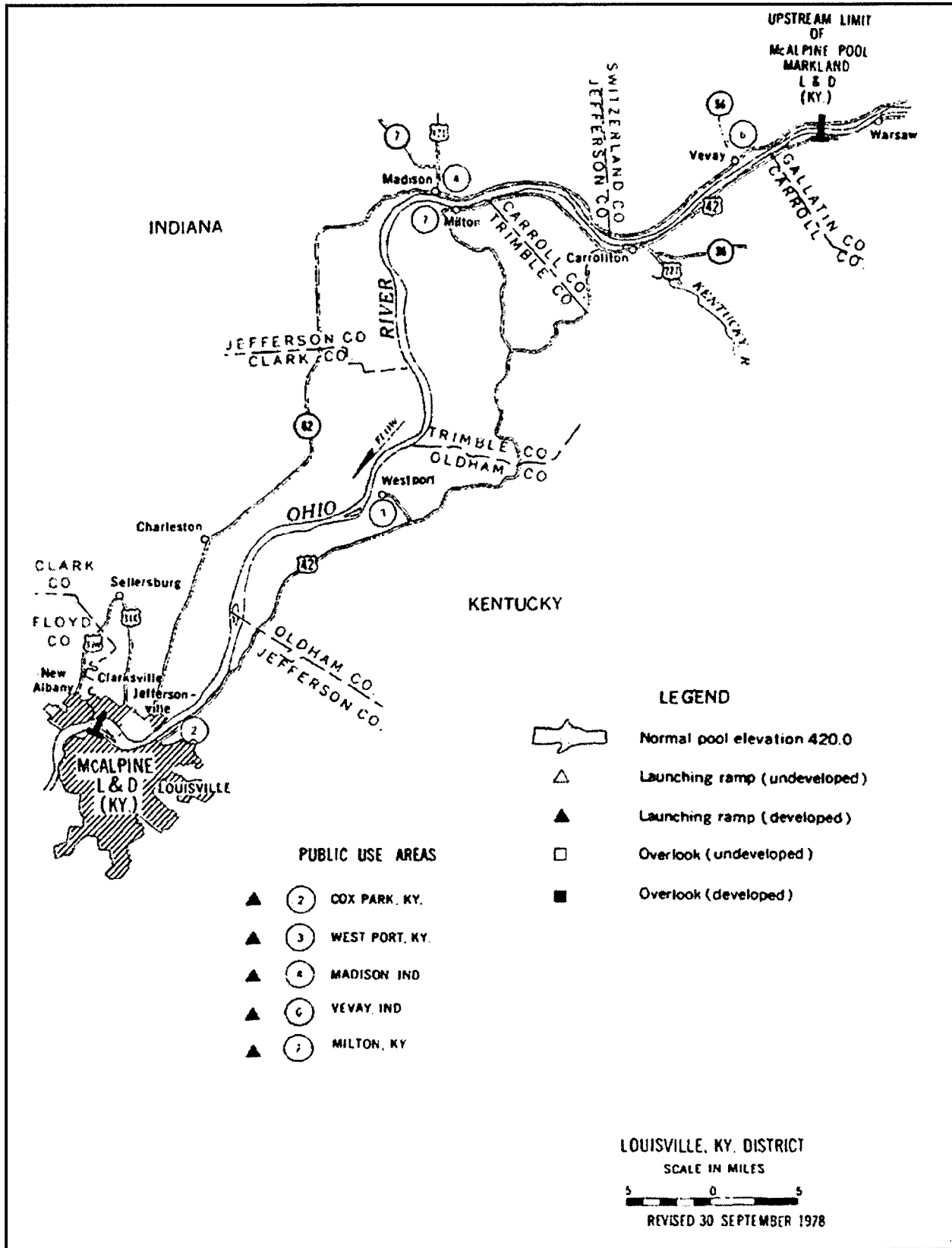

Figure 1. Location map

Originally, a split-lateral filling and emptying system similar to the existing 365.76-m (1,200-ft) lock was proposed for the new lock. The split-lateral design used on several medium-lift locks on the Ohio River (e.g., St. Anthony Falls Hydraulic Laboratory 1962) has culverts located in the lock walls with lateral manifolds constructed in the lock floor.

The system discussed in this report features intakes located in the upper approach walls, discharge manifolds located between the two 365.76-m (1,200-ft) locks, and an in-chamber longitudinal culvert filling and emptying system.

Purpose and Scope

An ILCS design was developed by Stockstill (1998) as part of the multi-district research effort to evaluate innovative lock designs. The research model incorporated through-the-sill intakes and outlets with butterfly valves to control the flow. The New McAlpine lock design presented in this study contained intakes located in the upper approach walls and an outlet that discharged outside the lock walls. The culverts were located in the lock walls between the intakes and the valve wells. Downstream from the valves the culverts turned through the lock walls into the chamber. Downstream from the in-chamber longitudinal culverts, the culverts passed back through the lock walls to the outlet manifolds outside the chamber. The flow was controlled by reverse tainter valves. Due to the differences in the intakes, outlets, and valves, a second model study was necessary to verify the design.

The specific objectives of the study were to determine the following:

- a. Filling and emptying times for various valve speeds at the design lift of 11.28 m (37 ft.)
- b. Flow conditions and vortex tendencies in the upper approach during filling operations.
- c. Hawser forces exerted on barges moored in the lock chamber.
- d. Pressures in the culverts.

A laboratory model was used to evaluate the performance of the filling and emptying system. Model studies of lock filling and emptying systems designed for barge traffic have targeted maximum hawser forces of 44.48 kN (5 tons) as a design objective. System design and operation are optimized such that a full tow at design draft produce hawser forces of 5 tons or less during lock operations at the design pool conditions. This limiting maximum hawser force guidance is provided in paragraph 8-6 of EM 1110-2-2602 "Planning and design of navigation locks," paragraph E-2 of EM 1110-2-1604 (HQUSACE 1995a) and also in the discussion of permissible filling times in paragraph D-15 of EM 1110-2-1604 (HQUSACE 1995b). Davis (1989) summarizes the findings of physical model studies:

“In working with models to determine hawser stresses, it must be noted that when a hawser stress of only 5 tons is achieved in a model it does not necessarily follow that the hawser stress on the prototype lock will be no greater than the value measured in the model. On a performance basis it has been found that when the model hawser stress is no greater than 5 tons, the prototype lock will perform very well and no surging or severe turbulence will occur.”

2 Physical Model

Description

The 1:25-scale model reproduced approximately 213.36 m (700 ft) of the upper approach, 38.10 m (125 ft) of the lower approach, the intakes, filling and emptying culverts and valves, and the discharge outlet manifolds. The upper approach, lower approach, lock chamber floor and walls, and the miter gate were constructed of plastic-coated plywood. The filling and emptying system, including the intakes, filling and emptying culverts, and the discharge outlet manifolds were constructed of plastic and the filling and emptying valves were built from brass (Figure 2). A model layout is shown in Plate 1.

Details of the filling and emptying system are provided in Plate 2. The proposed filling and emptying system consisted of two intakes located as shown in Plate 3. The left intake was located on the left guide wall approximately 99.82 m (327.5 ft) from the upstream pintle and consisted of eight ports 4.88-m- (16-ft-) high with the top of the intake at el 397 as shown in Plate 4. The right intake was located approximately 57.61 m (189 ft) upstream from the pintle at the end of the right wall with the top of the intake also at el 397. The right intake was semi-circular shaped and contains six ports 4.88-m- (16-ft-) high as shown in Plate 5. The port-to-culvert area ratio for the right intake was 2.7 [port intake area = 6 ports x 2.44 m x 4.88 m = 71.35 m² (6 ports x 8 ft x 16 ft = 768 ft²)]. The port-to-culvert area ratio for the left intake was 2.9 [port intake area = 8 ports x 1.98 m x 4.88 m = 77.30 m² (8 ports x 6.5 ft x 16 ft = 832 ft²)]. Both intakes transition to 4.88-m-high- by 5.49-m-wide- (16-ft-high- by 18-ft-wide-) culverts located in the lock walls. The culverts contain a vertical transition between stas 18+15 and 18+76 where the floor el drops from 381 to 365 and another vertical transition between stas 20+00 and 20+64 where the invert lowers to el 348. The filling valve wells and bulkhead slots are located between stas 18+76 and 19+32. Both culverts contain horizontal curves between stas 20+64 and 21+30 where the culverts turn into the lock chamber. Both chamber culverts begin at sta 21+30.04. The left culvert extends to sta 31+01 and the right culvert to sta 30+51 where they turn outside the right lock wall. Details of the chamber culverts and ports are shown in Plates 6 and 7. The filling and emptying manifold port-to-culvert area ratio was 0.97. The discharge outlets consisted of two manifolds each with 16 ports, eight on each side located as shown in Plate 8. The outlet manifold port-to-culvert area ratio was 1.8 [outlet port area = 16 ports x 2.44 m x 1.22 m = 47.57 m² (16 ports x 8 ft x 4 ft = 512 ft²)].

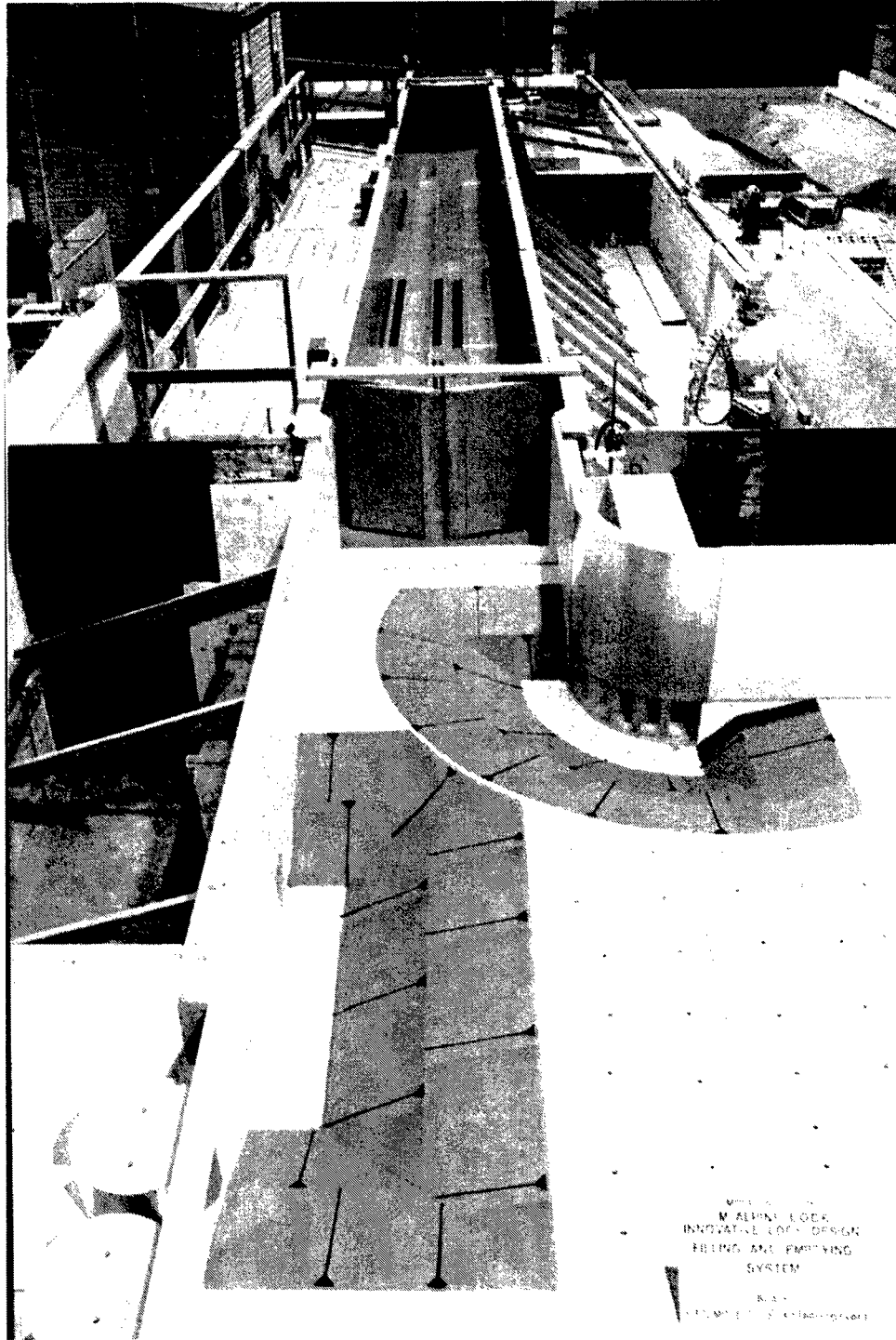

a. with upper gate

Figure 2. Dry bed view of Type 1 (original) design looking downstream, scale model of the McAlpine Lock (continued)

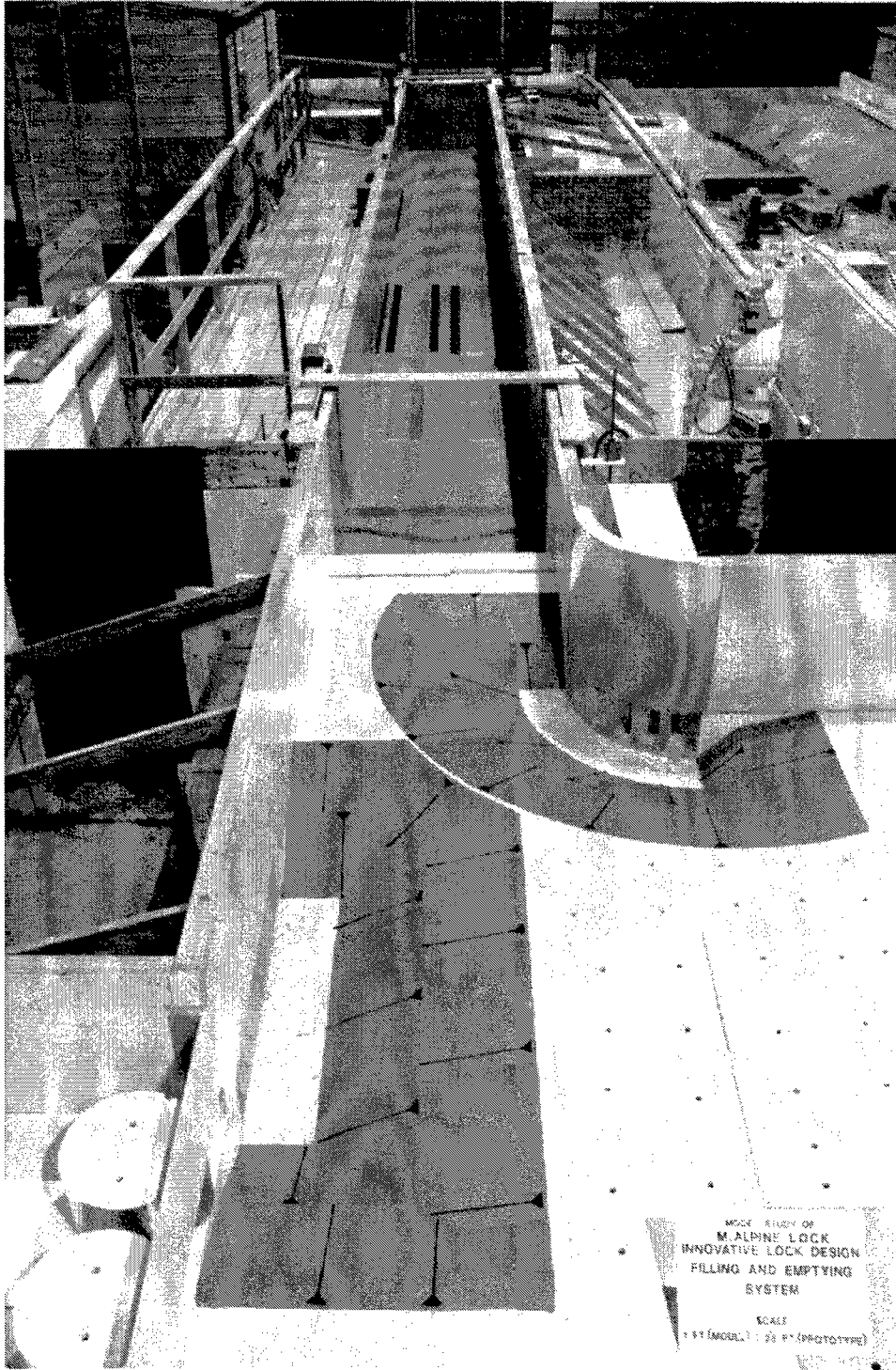

b. without upper gate

Figure 2. (Concluded)

Appurtenances and Instrumentation

Water was supplied to the model through a circulating system. The upper and lower pools were maintained at near constant elevations during the filling and emptying operations using constant head skimming weirs in the model headbay and tailbay. During a typical filling operation, excess flow was allowed to drain over the weirs at the beginning of the fill operation and minimal flow over the weir was maintained at the peak discharge thereby minimizing the drawdown in the upper reservoir. The opposite of this operation was performed during lock emptying. Upper and lower pool elevations were set to the desired level by adjusting the skimming weirs and reading piezometers placed in calm areas of the upper and lower pools. Water-surface elevations inside the chamber were determined from electronic pressure cells located in the middle and on each end of the lock chamber. Pressure cells were also used to measure instantaneous pressures in the culvert just downstream of the filling and emptying valves. Histories of the end-to-end water-surface differential were also recorded during filling and emptying operations. Dye and confetti were used to study subsurface and surface current directions. Pressures throughout the systems were measured with piezometers (open-air manometers). Pressures obtained in this manner are considered average pressures because of the reduction in frequency response resulting from the use of nylon tubing.

An automated data acquisition and control program, Lock Control, written by Dr. Barry McCleave of the ERDC Information Technology Laboratory (ITL) was used to control valve operations and collect pressure and strain gauge data. Thirteen data channels were used, four for control of the filling and emptying valves, six for pressure data, and three for collecting strain gauge information. The data were usually collected at a sampling rate of 50 Hz. Some of the hawser force and lock filling and emptying data were collected at 10 Hz. These data were then processed using a computer program written by Dr. Richard Stockstill of the ERDC Coastal and Hydraulics Laboratory (CHL). The processed data were used to determine lock filling and emptying times, longitudinal and transverse hawser forces, and pressures downstream from the filling and emptying valves.

A hawser-pull (force links) device used for measuring the longitudinal and transverse forces acting on a tow in the lock chamber during filling and emptying operations is shown in Figure 3. Three such devices were used: one measured longitudinal forces and the other two measured transverse forces on the downstream and upstream ends of the tow, respectively. These links were machined from aluminum and had SR-4 strain gauges cemented to the inner and outer edges. When the device was mounted on the tow, one end of the link was pin-connected to the tow while the other end was engaged to a fixed vertical rod. While connected to the tow, the link was free to move up and down with changes in the water surface in the lock. Any horizontal motion of the tow caused the links to deform and vary the signal which was recorded with a personal computer using an analog-to-digital converter. The links were calibrated by inducing deflection with known weights. Instantaneous pressure and strain gauge data were recorded digitally with a personal computer.

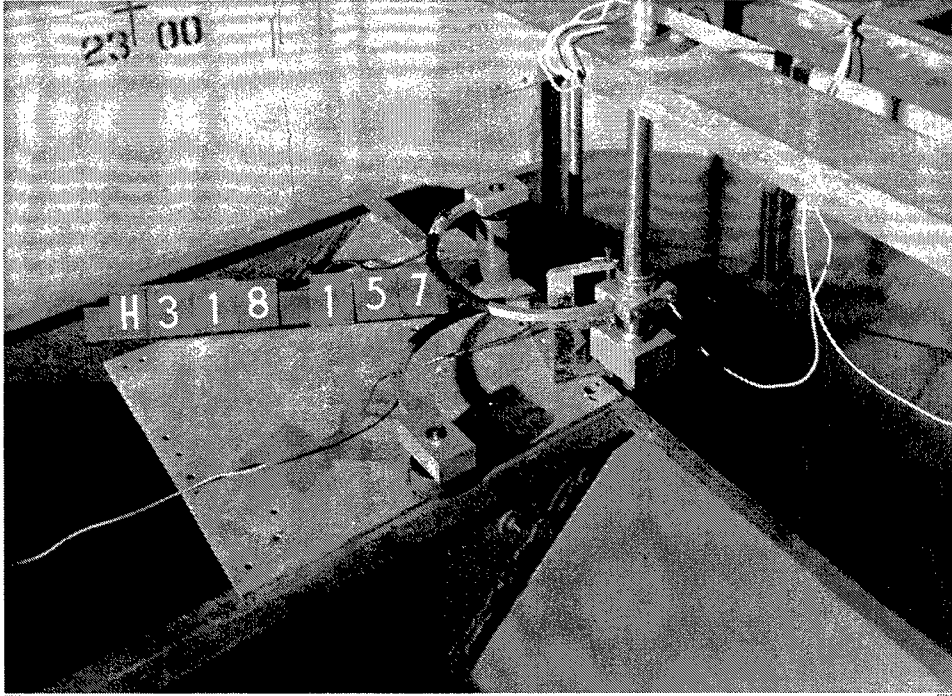

Figure 3. Hawser-pull (force links) measuring device

Similitude Considerations

Kinematic similitude

Kinematic similarity is an appropriate method of modeling free-surface flows in which the viscous stresses are negligible. Kinematic similitude requires that the ratio of inertial forces ($\rho V^2 L^2$) to gravitational forces ($\rho g L^3$) in the model are equal to those of the prototype. Here, ρ is the fluid density, V is the fluid velocity, L is a characteristic length, and g is the acceleration due to gravity. This ratio is generally expressed as the Froude number, N_F .

$$N_F = \frac{V}{\sqrt{gL}} \quad (1)$$

where L , the characteristic length, is usually taken as the flow depth in open-channel flow.

The Froude number can be viewed in terms of the flow characteristics. Because a surface disturbance travels at celerity of a gravity wave, $(gh)^{1/2}$, where h is the flow depth, it is seen that the Froude number describes the ratio of advection speed to the gravity wave celerity. Evaluation of the lock chamber performance primarily concerns modeling of hawser forces on moored barges during filling and emptying operations. These hawser forces are generated

primarily by slopes in the lock chamber water surface. The tow's bow-to-stern water-surface differentials are the result of long period seiches or oscillations in the lock chamber. Seiching is gravity waves traveling in the longitudinal direction from the upper miter gates to the lower miter gates. Equating Froude numbers in the model and prototype is an appropriate means of modeling the lock chamber.

Dynamic similitude

Modeling of forces is a significant purpose of the laboratory investigation. Appropriate scaling of viscous forces requires the model be dynamically similar to the prototype. Dynamic similarity is accomplished when the ratios of the inertia forces to viscous forces (μVL) of the model and prototype are equal. Here, μ is the fluid viscosity. This ratio of inertia to viscous forces is usually expressed as the Reynolds number

$$N_R = \frac{VL}{\nu} \quad (2)$$

where ν is the kinematic viscosity of the fluid ($\nu = \mu / \rho$) and the pipe diameter is usually chosen as the characteristic length, L , in pressure flow analysis.

Similitude for lock models

Numerous studies conducted to investigate vortex formation at intakes associated with critical submergence (generally defined as the submergence where an air-core vortex enters the intake) have indicated that the Froude number is an important parameter. The Froude number similarity is customarily used to model vortices although corrections to model results are sometimes used to account for surface tension and viscous effects between the model and the prototype (Knauss 1987). Using a scale of 1 to 25 (model to prototype) as is the case with this lock model, minimizes the surface tension and viscous effects and provides acceptable results based on the Froude number similarity.

Complete similitude in a laboratory model is attained when geometric, kinematic, and dynamic similitude are satisfied. Physical models of hydraulic structures with both internal flow (pressure flow) and external flow (free surface) typically are scaled using kinematic (Froudian) similitude at a large enough scale so that the viscous effects in the scaled model can be neglected. More than 50 model and 10 prototype studies of lock filling and emptying systems have been investigated (Pickett and Neilson 1988). The majority of these physical model studies used a scale of 1 to 25 (model to prototype). Lock model velocities scaled using kinematic similitude (model Froude number equal to prototype Froude number) in a 1:25-scale model have maximum Reynolds numbers at peak discharges on the order of 10^5 yet the corresponding prototype values are on the order of 10^7 .

Boundary friction losses in lock culverts are empirically described using the “smooth-pipe” curve of the Darcy-Weisbach friction factor where the headloss is expressed as

$$H_f = f \frac{L}{D} \frac{V^2}{2g} \quad (3)$$

where H_f is the headloss due to boundary friction, f is the Darcy-Weisbach friction factor, L is the culvert length, and D is the culvert diameter. The Darcy-Weisbach friction factor for turbulent flow in smooth pipes is given in an implicit form (Vennard and Street 1982)

$$\frac{1}{\sqrt{f}} = 2.0 \log (N_R \sqrt{f}) - 0.8 \quad (4)$$

Because f decreases with increasing N_R , the model is hydraulically “too rough”. The scaled friction losses in the model will be larger than those experienced by the prototype structure. Consequently, the scaled velocities (and discharges) in the model will be less and the scaled pressures within the culverts will be higher than those of the prototype. Low pressures were not a major concern with the McAlpine design; however, the lower discharges would in turn result in longer filling and emptying times in the model than the prototype will experience. Prototype filling and emptying times for similar designs will be less than those measured in a 1:25-scale lock model.

Modeling of lock filling and emptying systems is not entirely quantitative. The system is composed of pressure flow conduits and open-channel components. Further complicating matters, the flow is unsteady. Discharges (therefore N_F and N_R) vary from no flow at the beginning of an operation to peak flows within a few minutes and then return to no flow at the end of the cycle. Fortunately though, engineers now have about 50 years of experience in conducting large-scale models and subsequently studying the corresponding prototype performance. This study used a 1:25-scale Froudian model in which the viscous differences were small and could be estimated based on previously reported model-to-prototype comparisons. Setting the model and prototype Froude numbers equal results in the following relations between the dimensions and hydraulic quantities:

Characteristic	Dimension ¹	Scale Relation Model :Prototype
Length	$L_r = L$	1:25
Pressure	$P_r = L_r$	1:25
Area	$A_r = L_r^2$	1:625
Velocity	$V_r = L_r^{1/2}$	1:5
Discharge	$Q_r = L_r^{5/2}$	1:3, 125
Time	$T_r = L_r^{1/2}$	1:5
Force	$F_r = L_r^3$	1:15,625
¹ Dimensions are in terms of length.		

These relations were used to transfer model data to prototype equivalents and vice versa.

Experimental Procedures

Evaluation of the various elements of the lock system was based on data obtained during typical filling and emptying operations. Performance was based primarily on hawser forces on tows in lockage, roughness of the water surface, pressures, and time required for filling and emptying. Quantification of energy loss coefficients was made using fixed-head (steady-flow) conditions with the culvert valve and/or miter gates fully opened or closed.

3 Model Experiments and Results

Type 1 Design

Initial experiments

Initial model experiments were performed to evaluate the performance of the type 1 (original) design with an upper pool el of 420, a lower pool el of 383, and 2-, 4-, and 8-min valve operations. These upper and lower pool conditions represented the 11.27-m (37-ft) lift, the maximum that occurs at the McAlpine Project. In this report, the 11.27-m (37-ft) lift can be assumed unless otherwise stated. The valve operating curves used for these initial experiments are shown in Plate 9.

Large water-surface oscillations (and hawser forces) occur during periods of rapid flow acceleration when the rate of rise during filling (or the rate of fall for emptying) is near a maximum value. The natural periods T_n of longitudinal and transverse oscillations of the lock chamber can be expressed as (Weigel 1964)

$$T_n = \frac{2\lambda}{n \left(\frac{gL}{2\pi} \tanh \frac{2\pi d}{L} \right)^{1/2}} \quad (5)$$

where

λ = length of the lock chamber for longitudinal and width of lock chamber for transverse in ft

n = mode

L = wave length; $L = 2\lambda/n$

d = cushion depth in the lock chamber

In Figure 4, natural periods of oscillation are plotted by means of the previous equation for the first and second modes of oscillation in the longitudinal and

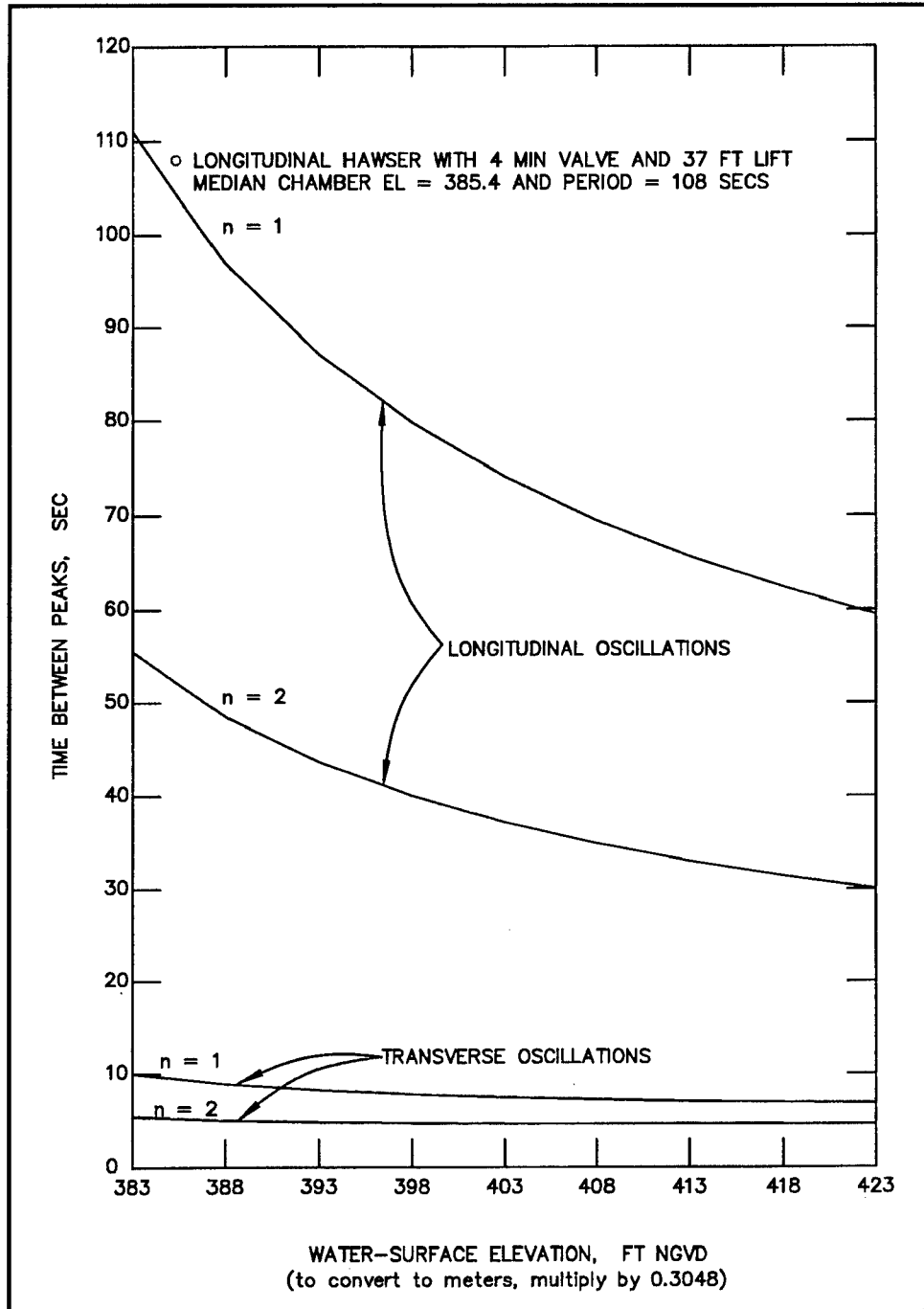

Figure 4. Approximate periods of oscillation

transverse directions for a lock length of 384.05 m (1,260 ft), width of 33.53 m (110 ft), and cushion depths d , of 4.88 m (16 ft) at a lower pool el of 383 and a d of 17.07 m (56 ft) at an upper pool el of 423. This figure is included to illustrate the periods of oscillation inside the lock chamber that can occur during a filling operation. The period of the data point provided in Figure 4 was determined from model hawser force time history data (which will be explained in the following sections) for a lock filling experiment with a 4-min valve operation and a 11.28-m (37-ft) lift. The period of the longitudinal hawser force data is close to the period

computed for the first mode of oscillation for the median chamber depth (water-surface el 385.4). As will be observed in the model data, the maximum longitudinal hawser forces during a filling operation will generally oscillate near these periods.

Hawser forces, 2-min valve operation

The first experiment was performed with a 2-min filling valve operation. The maximum longitudinal hawsers exceeded the calibration step used for the strain gauges which meant the forces were considerably higher than desired. The maximum upstream transverse hawsers were greater than 80.07 kN (9 tons), and the maximum downstream transverse hawsers were 112.10 kN (12.6 tons). The lock filled in 9.3 min with the 2-min valve operation. Time histories of the hawser forces, the filling curve, and the piezometric head downstream from the filling valve are shown in Plate 10. The data indicate the 2-min valve operation was too fast to achieve desirable chamber performance. As a general practice, three tests were performed to insure repeatability. The initial downstream longitudinal hawser forces were too high and the upstream longitudinal hawsers that occurred later in the filling cycle were even larger. The pressure downstream from the valve was lower than the culvert roof el between 0.5 and 1.5 min into the filling operation. Air will be drawn into the culvert during this period if it is available. The bulkhead slots were sealed in the model to avoid this occurrence. The test indicated that the flow entering the chamber shortly after the valves were fully open was unbalanced and higher water-surface elevations were occurring in the lower part of the chamber.

Hawser forces, 4-min valve operation

Experiments were conducted next with a 4-min valve operation. The average maximum longitudinal hawser force determined from three experiments was 154.80 kN (17.4 tons) and occurred in the upstream direction around 5 min into the filling cycle. Time histories of the hawser forces, the filling curve, and the piezometric head downstream from the filling valve are shown in Plate 11 for the Type 1 design and 4-min valve operation. Observation of the water surface in the chamber during filling without barges indicated a very rough surface occurred at the lower end of the chamber shortly after the valve was fully open. The surface appeared to bulk in the center of the chamber near the middle of the downstream ports first and then, shortly thereafter, the surface became very turbulent in the lower end of the chamber where the floor transitions upward from el 360.5 to el 367. The high longitudinal hawser forces in the upstream direction confirmed that higher water surfaces were occurring in the lower end of the chamber during filling. The maximum right (looking downstream) transverse hawser force measured with the 4-min valve was 93.41 kN (10.5 tons) and occurred on the downstream hawser. The maximum left transverse hawser force was 48.93 kN (5.5 tons) and occurred on the upstream hawser. The lock filled in 10.6 min with the 4-min valve operation. The maximum hawser forces with the 4-min valve occurred just after the filling valves were fully open as seen in Plate 11. A plot of the average maximum hawser forces versus filling time for the 4- and 8- min

valve operations with the Type 1 filling and emptying system is shown in Plate 12.

Hawser forces, 8-min valve operation

Hawser forces were then measured with an 8-min valve operation. The average maximum longitudinal hawser force was 41.81 kN (4.7 tons) and occurred in the downstream direction. The average maximum right transverse hawser force measured with the 8-min valve was 27.58 kN (3.1 tons) and occurred on the downstream hawser. The average maximum left transverse hawser forces was 37.37 kN (4.2 tons) and occurred on the downstream hawser. The lock filled in 12.7 min with the 8-min valve operation. Time-histories of the hawser forces, the filling curve, and the piezometric head downstream from the filling valve are shown in Plate 13 for the Type 1 design and 8-min valve operation. The maximum longitudinal hawser force occurred about 1 min into the fill cycle and the maximum transverse hawser forces occurred just after the fill valves were fully open (see Plate 13).

Intake Vortex Experiments

Experiments were performed next to determine the lock approach flow conditions and the intake performance. Vortex experiments were conducted by documenting the strength of vortices that formed in the upper approach for various valve operations. The strength of the vortex varies from a Type 1 vortex which is a noticeable surface swirl to a Type 6 which has an air-core that begins at the water surface and enters the intake. The vortex strength classification used for the McAlpine lock model experiments is shown in Plate 14 and was adopted from the Alden Research Classification. Criteria for modeling vortices at this scale suggest that vortices that are Type 4 or stronger should be avoided. Vortices observed in the model that are a Type 3 or weaker, are less likely to form strong vortices in the prototype. Experiments were conducted by selecting the desired valve opening time with an upper pool el of 420 and a lower pool el of 383. Vortex experiments were performed for 2-, 4-, and 8-min valve opening times. A minimum of 15 min (model time) was allowed between each experiment to insure all currents generated from the previous experiment had ceased and experiments were repeated until the performance of the intake with that particular valve operation was established. Typically, six experiments were performed for each condition and in all cases both filling valves were operated synchronously.

The results from experiments performed with the 2- min valve opening and left intake are provided in Table 1. Six experiments were conducted and a Type 4 vortex was documented in two of the six experiments and a Type 5 vortex formed in the third experiment. The location of the Type 5 vortex is shown in Plate 14. The vortices usually formed rapidly and were drawn towards the intake where the strength was dissipated as a result of contact with the approach wall. The results from experiments performed with the 2-min valve opening and right intake are provided in Table 2. Types 4 and 5 vortices occurred in all six experiments at the

locations shown in Plate 15. These vortices generally occurred when flow from the vicinity of the upper miter gate was redirected in an upstream direction and moved out of the upper approach. The flow circulated in the vicinity of the right intake and often intensified as it was drawn downward into the intake. The strength usually reduced in a matter of seconds.

Experiments were conducted next with the 4-min normal valve operation. The results from these experiments with the left intake are listed in Table 3. A Type 6 formed in one of the six experiments as shown in Plate 16, however the maximum strength vortex observed in the other five experiments was a Type 2. Since the Type 6 was not repeatable, it was not considered representative of the approach flow conditions with a 4-min valve operation. The observations documented with the 4-min valve and the right intake are listed in Table 4. A Type 5 vortex was observed in four of the five experiments in the locations shown in Plate 16. This was considered a strong vortex and was not desired in the upper approach during filling.

Documentation of vortex formation in the upper approach was performed next with the 8-min valve operation. The maximum strength vortex observed in 11 of the 12 experiments (six for each intake) was a Type 2, Tables 5 and 6. In the sixth experiment on the right intake, a Type 5 vortex formed in a location similar to those shown in Plate 16 with the 4-min valve. Since this only occurred once during the six experiments on the right intake, it was not considered representative of the flow conditions in the vicinity of the right intake with the 8-min valve operation.

Vortex experiments indicated strong vortices were present with the Type 1 design during filling operations with valve speeds equal to and faster than 4 min. The vortices occurred more frequently in front of the right intake on the right side of the intake.

LRL indicated the goal for the filling time was around 11 min. The filling time with the Type 1 design to maintain hawser forces of 44.48 kN (5 tons) or less was in excess of 12 min. Chamber modifications were necessary to improve performance and reduce the fill time.

Type 2 Chamber Design

Port extensions were placed on all ports in the chamber as shown in Plate 17. The details of the port extensions are the same as the original design shown in Plate 6. To save time, chamber performance was evaluated based on the maximum end- to -end water-surface differential measured during a selected filling operation, because hawser forces result primarily from water-surface slopes in the chamber. The port extensions were installed on the downstream ports in an effort to reduce the water-surface bulking in this end of the chamber. The maximum water-surface end- to -end differential measured in previous tests with the Type 1 chamber for a 4-min valve was -0.137 m (-0.45 ft). This differential occurred over a longitudinal distance of 371.86 m (1,220 ft). This longitudinal distance was the same for all experiments. The negative sign

indicates the water surface is higher in the downstream end of the lock chamber. A higher water surface in the downstream end of the chamber causes an upstream longitudinal hawser force. The largest end- to -end differential measured in the downstream direction with the Type 1 chamber design and the 4-min valve was 0.085 m (0.28 ft). The maximum end to end water-surface differentials measured with the Type 2 chamber design and 4-min valve was -0.061 m (-0.2 ft) in the upstream direction and 0.119 m (0.39 ft) in the downstream direction. This performance of the Type 2 chamber was almost opposite from that observed with the Type 1 chamber design. This meant the port extensions were effective in reducing the bulking and higher water-surface elevations observed in the downstream end of the chamber, although now the upstream water surface was causing excessive slopes. A chart indicating maximum water-surface differentials measured for the Types 1 and 2 chamber designs is provided in Plate 18 along with other designs that will be discussed subsequently.

Type 3 Chamber Design

Additional baffles 0.61 m high by 0.61 m wide (2 ft high by 2 ft wide), which extended along the outside of the upstream port extensions were placed in the upstream portion of the chamber as shown in Plate 19. This design with port extensions on all the ports and the 0.61-m by 0.61-m (2- ft by 2- ft) baffles on the upstream ports was designated the Type 3 chamber design. The maximum end to end water-surface differentials measured with this design were -0.046 m (-0.15 ft) and 0.158 m (0.52 ft) (see Plate 18) indicating the water-surface elevations in the upstream end of the chamber during filling were still too high.

Type 4 Chamber Design

The baffles were removed from the upstream ports nearest the lock walls as shown in Plate 20. This modification was noted as the Type 4 chamber design and experiments were performed to determine if a better balance in chamber water level could be achieved during filling operations with the 4-min valve. The maximum end to end water-surface differential was reduced with this design as shown in Plate 18, but the differential between the upper and lower water surfaces was still 0.137 m (0.45 ft) and was considered too high.

Type 5 Chamber Design

The 0.61- m by 0.61- m (2- ft by 2- ft) baffles were removed from the upstream ports along with the port extensions on the outside of the downstream ports (Type 5 chamber design in Plate 21). The maximum end-to-end water-surface differentials were less than the Type 4 design as shown in Plate 18. This reduction in differential indicated the flow entering the chamber was more balanced than the previous designs.

Types 6 and 7 Chamber Designs

The baffles located on the lock walls adjacent to upstream ports were increased in width from 0.61 to 0.91 m (2 to 3 ft) as shown in Plate 22. This design was the Type 6 chamber and chamber performance was improved over the Type 5 chamber design as seen by the reduced water-surface differentials shown in Plate 18. The 0.91-m (3-ft) wall baffle helped to distribute the flow better in the upper portion of the lock chamber. The wall baffles in the downstream portion of the lock chamber were increased in width from 0.61 to 0.91 m (2 to 3 ft), Type 7 chamber design shown in Plate 23. The flow in the chamber was better distributed than the Type 6 chamber design although the end-to-end water-surface differentials was slightly higher. These end-to-end water-surface differentials with the Type 7 chamber are shown in Plate 18.

Type 8 Chamber Design

In an effort to further improve the performance of the chamber during filling operations with the 4-min valve operation, the last four port extensions were removed from the center section of the downstream ports. This modification was designated the Type 8 chamber design and is shown Plate 24. The maximum end-to-end water-surface differentials measured with the Type 8 chamber design were -0.046 m and 0.058 m (-0.15 ft and 0.19 ft). These differentials were similar and were not excessive, therefore the 3 by 6 barge arrangement was placed inside the chamber to conduct hawser load experiments.

Hawser forces measured with the Type 8 chamber design for 4-, 5-, and 8-min valve operations are shown in Plate 25. The downstream longitudinal hawser force measured with the 4-min valve was 88.96 kN (10 tons) which was higher than desired. These same hawser forces with the 5-min valve were 67.61 kN (7.6 tons) which was still higher than desired. Time-histories of the hawser forces, the filling curve, and the piezometric head downstream from the filling valve are shown in Plate 26 for the Type 8 design and 5-min valve operation. The maximum longitudinal hawsers occurred between 1 and 2 min into the filling cycle and were in the downstream direction. The maximum transverse hawsers occurred just after the filling valves were fully open. The lock filling time measured with the 5-min valve was 10.6 min.

Type 9 Chamber Design

Port extensions were removed from the first inside ports of the downstream ported section as shown in Plate 27. This change was the Type 9 chamber design and was done in an attempt to distribute the flow better in the lower half of the lock chamber. There was a slight reduction in the downstream longitudinal hawser forces measured with the 5-min valve, 66.72 kN (7.5 tons), along with a reduced filling time of 10.5 min.

Type 10 Chamber Design

The 0.61-m by 0.61-m (2-ft by 2-ft) floor baffle was placed back on the upstream inside ports as shown in Plate 28 to determine if the flow distribution in the chamber could be improved. This modification was the Type 10 chamber design and the hawser forces measured with this design were higher than the Type 9 chamber design indicating no improvement in performance.

Type 11 Chamber Design

The floor baffle was removed from the upstream ports and vertical wall baffles were placed underneath the horizontal wall baffles as shown in Plate 29. This modification was designated the Type 11 chamber design. The vertical wall baffles should help dissipate the energy of the jets discharging from the outside ports and distribute the flow better in the chamber. The hawser forces measured with the Type 11 chamber design are shown in Plate 30. The maximum longitudinal downstream hawsers were reduced slightly from the previous designs, but were still higher, 65.83 kN (7.4 tons), than 44.48 kN (5 tons) with the 5-min valve operation and the 11.28-m (37-ft) lift. Time-histories of the hawser forces, the filling curve, and the piezometric head downstream from the filling valve are shown in Plate 31 for the Type 11 design and 5-min valve operation. The maximum longitudinal hawsers occurred between 0 and 1 min into the filling cycle and were in the downstream direction. The filling time with the 5-min valve operation was 10.8 min. The hawser forces measured with the 8-min valve operation were all under 44.48 kN (5 tons) and the filling time was 12.3 min.

Type 12 Chamber Design

Experiments were continued to try and develop modifications to reduce hawser forces with the 5-min valve operation. A T-shaped baffle was installed along the center of the lock between the upstream ports as shown in Plate 32, Type 12 chamber design. Hawser forces were increased with this design so this approach was abandoned and the T-shaped baffle was removed.

Type 13 Chamber Design

The downstream longitudinal hawsers were the ones higher than desired. This indicated a larger buildup of flow in the upstream end of the chamber. In an effort to reduce this flow, the first two pairs of ports in the upstream end of the chamber were plugged. The filling and emptying manifold port-to-culvert area ratio was 0.91. This change was designated the Type 13 chamber design shown in Plate 33. A slight reduction in the downstream longitudinal hawser forces was achieved with this modification with the 5-min valve. However, the transverse

forces were increased. The Type 11 chamber design was considered better than both the Types 12 and 13 designs.

Numerous minor modifications had been made to the chamber to try and produce acceptable performance with the 5-min valve and 11.28-m (37-ft) lift. The best design was the Type 11 chamber. The maximum downstream longitudinal hawser force measured with the 5-min valve was 65.83 kN (7.4 tons) and the filling time was 10.8 min. These results were close to the 44.48-kN (5-ton) limit and 11-min fill time, but the hawser forces were still slightly higher than desired. Experiments were performed next with varying valve speeds to try and reduce hawser forces and maintain an acceptable filling time. The Type 11 chamber design was used for these experiments.

Varying Valve Speed Experiments

Experiments were performed with a valve operation that consisted of 4-min of operation using an 8-min valve schedule and then 1 min to fully open. Results showed, shortly after the valve was fully open, large upstream hawser forces occurred. The maximum longitudinal hawser forces were 146.79 kN (16.5 tons) and the filling time was 11.5 min. This valve schedule is shown in Plate 34 and time histories of hawser forces and a filling curve for a typical experiment with this operation are shown in Plate 35. The next valve schedule performed was 2 min of operation with an 8 min valve schedule and 3 min to fully open. This valve schedule is also shown in Plate 34 and results from a typical experiment with this type operation are shown in Plate 36. The hawser forces were lower than the previous valve operation, but the performance was not any better than the Type 11 chamber design with the 5-min. valve. The pressure measured downstream from the filling valve was below the culvert roof el between 1 and 4-min into the filling operation as seen in Plate 36.

LRL furnished a valve schedule which consisted of two minutes of operation with an 8-min valve opening and then switching to a valve speed which corresponds to a 5-min valve. This operation was continued until near the end of the cycle when the valve was decelerated to its stopping point. This valve schedule is shown in Plate 34 along with the other valve operations. Results from a typical experiment with this operation are shown in Plate 37. The maximum hawser forces were less than 44.48 kN (5 tons) and the filling time was 11.3 min. This operation was considered acceptable. Confetti illustrating the surface currents within the lock chamber during filling with this valve schedule are provided in Photos 1-6. Type 11 (recommended) design was used with the Louisville District's valve schedule. The time exposure was 10 sec.

Lock Emptying Operations

The performance of the Type 11 chamber design was evaluated during emptying operations with 4-, 5-, and 8-min valve schedules. Time-histories of the longitudinal and transverse hawser forces and the emptying curve are shown in

Plates 38-40 for these respective valve operations with the Type 11 chamber design. Plate 41 shows the average maximum hawser forces measured during lock emptying for the 4-, 5-, and 8-min valve operations with the Types 1 and 11 design chambers. The hawsers were considered acceptable for valve operations of 4 min and slower. The Type 11 design emptied in 11.2 min with the 11.28-m (37-ft) lift and 4-min valve.

Pressure Measurements

Instantaneous pressures were measured with a pressure cell mounted on the roof of the culvert downstream of the filling valve (sta 19+32, Plate 42). The pressure just downstream of the filling valves can become excessively low in conjunction with the high velocities occurring during partial gate openings. A time-history of the pressure just downstream of the filling valves for a typical filling operation with a 5-min valve time is presented in Plate 31. The experimental results indicate the pressure drops below the culvert roof el a few ft between during the first 3.5 min into the filling operation. The negative pressures occurring during this time will draw air into the culvert if it is available. This will result in air pockets being expelled within the chamber producing an excessively rough water surface. Bulkhead slot covers or caps should be provided to prevent air from being drawn into the culvert. The duration of these negative pressures will be longer with slower valve times. However they are not considered excessively low.

Additional pressures occurring during steady flow were measured at various locations throughout the system using piezometers located as shown in Plate 42. These measurements were used to quantify loss coefficients for various components of the system. Energy loss through each component is expressed as

$$H_{Li} = K_i \frac{V^2}{2g} \quad (6)$$

where K_i is the loss coefficient for component i , and V is the culvert velocity which is one-half of the total discharge divided by a culvert area of 4.88 m by 5.49 m (16 ft by 18 ft). The total headloss through the system is

$$H_L = \sum H_{Li} = \sum K_i \frac{V^2}{2g} \quad (7)$$

The lock coefficient is defined as

$$C_L = \frac{V}{\sqrt{2gH_L}} \quad (8)$$

Equating the headloss, H_L , in each expression shows the relation between the lock coefficient and loss coefficient.

$$K = C_L^{-2} \quad \text{or} \quad C_L = K^{-0.5} \quad (9)$$

where K is the sum of each K_i .

The total energy loss coefficient for the filling system with the Type 11 design chamber, K , was determined to be 2.2. Distribution of this sum by lock filling components is illustrated in the following table. The corresponding overall lock coefficient, C_L , for the filling system was determined to be 0.67.

Component	Loss Coefficient, K_i
Intakes	0.2
Upstream Culvert, Valve, Transitions, and Curves	0.5
Upstream Culvert	0.2
Manifold	1.3

An equation typically used by the Corps to compute the overall lock coefficient is:

$$C_L = \frac{2 A_L \sqrt{H+d} - \sqrt{d}}{A_c (T - kt_v) \sqrt{2g}} \quad (10)$$

where

A_L = area of lock chamber, ft^2

H = initial head, ft

d = overtravel, ft

A_c = area of culverts, ft^2

T = filling time, sec

k = a constant

t_v = valve opening time, sec

g = acceleration due to gravity, ft/sec^2

For more information on the development of this equation refer to Davis (1989). The term $T-k t_v$ is the lock filling or emptying time for the hypothetical case of instantaneous valve operation and is determined directly from the curves presented in Plate 43. Computed coefficients for the Type 11 chamber design from this equation are $C_L = 0.65$ for filling and $C_L = 0.57$ for emptying with a lift of 11.28 m (37 ft). The lock coefficient for filling computed from this equation is slightly lower than the one determined from the steady-state pressure measurements. The previous equation contains pseudo inertial terms not accounted for in the steady-state analysis.

Additional Vortex Experiments

Additional vortex experiments were performed with roof extensions placed over the original design intakes to determine if the strength of the vortices that formed during filling operations could be reduced.

Type 2 roof extensions

Roof extensions were installed over each intake at el 400 as shown in Plate 44. The extensions were 3.05 m (10 ft) wide and made of thin sheet metal in the model and were noted as the Type 2 roof extensions. Experiments were performed with 4- and 8-min valve operations. Results with the 4-min valve are provided in Tables 7 and 8. The maximum strength vortex that formed with the 4-min valve was a Type 3 and occurred in two of the six experiments performed for the right intake, Table 8. A Type 4 vortex formed in the second experiment and a Type 3 vortex was observed in the second and third experiments in front of the left intake with the 8-min valve operation. Results from these experiments are provided in Table 9. A vortex with this strength had not been observed with the 8-min valve and no roof extension over the left intake. Results documented with the 8-min valve and right intake are listed in Table 10. The maximum strength vortex observed was a Type 1, a very weak vortex.

Type 3 roof extension

The roof extension was removed from the left intake due to the increase in vortex strength detected with the 8-min valve and another set of experiments were performed. This modification was designated the Type 3 roof extension, Plate 45, and experiments were conducted with 4-, 5-, and 8-min valve operations. Results from these experiments are provided in Tables 11-16. No vortex stronger than a Type 2 was observed in any of the experiments which indicates acceptable flow conditions in the upper approach for these valve operations and the 11.28-m (37-ft) lift. The experiments showed a 3.05-m- (10-ft-) wide roof extension at el 400 over the right intake was beneficial in reducing the vortex strength during filling operations, and a roof extension was not necessary over the left intake.

Outlet Manifold Experiments

Velocity measurements were obtained in the vicinity of the Type 1 outlet manifold to observe the distribution of flow. The measurements were taken at three locations in each port using a pitot tube placed normal to the port face. The locations were at the center of the port (el 352) and on both sides of the port at the same elevation. The entire port was not mapped due to time constraints. The measurements taken at the center were considered a reasonable representation of the flow distribution for the manifold. There were locations where measurements could not be obtained using the pitot tube due to the unsteadiness at the edges of the port. The upper pool was maintained at el 420 with the upper valves closed; the upper miter gates open; the lower valves open full; and the lower pool at el 383. The measurements obtained for the right culvert manifold are shown in Plate 46, and those obtained with the left culvert are shown in Plate 47. The flow was fairly well distributed in the right culvert manifold in the last six ports from the culvert. The two ports closest to the culvert have stronger downstream components of velocity than the components normal to the port face. In the left culvert manifold, the flow discharging from the last four ports from the culvert was fairly well distributed. As also observed in the right culvert, the ports closest to the culvert have a stronger downstream component of velocity. The surge effect of the outlet discharge was investigated concurrently in a general navigation model study of the McAlpine project conducted by personnel in the Navigation Branch of CHL.

Single Valve Experiments

Experiments were conducted to further evaluate the Type 11 chamber design with an upper pool el of 420 and a lower pool el of 383 for single valve operations. A 10-min valve schedule was used to fill the lock with only the left valve in operation. Time-histories of the hawser forces, water-surface elevation and piezometric head below the left filling valve were measured and are shown in Plate 48. The transverse hawser forces were higher than the longitudinal hawser forces. The maximum force, 71.17 kN (8 tons), occurred on the left upstream transverse hawser. Both the upstream and downstream transverse hawser forces indicate the 3 by 6 barge arrangement is pushed to left side (looking downstream) of the chamber during a single valve operation using the left valve. The filling time with the 10-min valve operation was 21.3 min. The piezometric head below the valve indicates that the pressure is lower than the roof el for approximately 6 to 7 min. Air will be drawn into the culvert if it is available and bulkhead covers should be used to minimize the air supply. The time-histories with only the right valve in operation are shown in Plate 49. The barge arrangement was pushed to the right side of the chamber. The maximum force occurred on the right upstream transverse hawser and was 62.28 kN (7 tons). A filling time of 21.2 min was determined for the 10-min valve operation.

Time-histories were measured next with a 12-min single valve operation to determine the hawser forces for this type of operation. The measurements with the left valve are shown in Plate 50 and the measurements with the right valve are

shown in Plate 51. The results were similar to the 10-min valve operation except the maximum hawser was 55.16 kN (6.2 tons) with the left valve and 52.49 kN (5.9 tons) with the right valve and the pressure downstream of the left filling valve was below the culvert roof el for approximately 8 min. These experiments indicate that with single valve filling operations and a lift of 11.28 m (37 ft), the valve opening speed should be slower than 12 min to avoid excessive hawser forces.

9.14 m (30 ft) Lift Experiments

A few experiments were conducted to observe the performance of the Type 11 chamber with a 9.14-m (30-ft) lift and submergence of 5.79 and 7.32 m (19 and 24 ft). The submergence is defined as the depth from the lower pool el to the top of the port (el 364). The 11.28-m (37-ft) lift condition with the upper pool el of 420 and the lower pool el of 383 gives a submergence of 5.79 m (19 ft). Table 17 lists the operating conditions and results from these experiments and also provides the results for the 11.28-m (37-ft) lift experiments for comparison. A plot of the hawser forces during filling with the 9.14-m (30-ft) lift and submergence of 5.79 and 7.32 m (19 and 24 ft) are shown in Plate 52. The plots show a slight increase in filling time with the higher submergence and a slight reduction in the downstream longitudinal hawser forces for the 4 and 5-min valve operation with the 7.32-m (24-ft) submergence. These differences were not considered significant.

4 Summary and Conclusions

Experiments to evaluate the performance of the In-chamber Longitudinal Culvert System (ILCS) for the New McAlpine Lock revealed the lock intakes, lock chamber, and valve operations required modifications to achieve the desired hydraulic performance. The chamber performance was not desirable with the original design because of the high hawser forces measured with normal valve operations up to 8 min. Several modifications were made to the chamber in an effort to reduce these hawser forces and distribute the flow evenly during filling operations. Placing the port extensions on the downstream center ports and increasing the width of the wall baffle from 2 to 3 ft proved effective in distributing flow in the chamber. The largest hawser forces measured with port extensions placed on all the downstream center ports were in the downstream longitudinal direction indicating a higher water-surface in the upper end of the chamber. This is a common tendency for culverts placed horizontally over the length of the chamber. Side port system data consistently show hawser traces similar to those reported in this investigation. Inertial effects within the filling culvert manifold result in flow issuing from the upstream ports before it does from the downstream ports. This produces a water-surface sloping in the downstream direction.

The Type 8 chamber design, which consisted of port extensions on all the downstream center ports except the last four pairs, was developed to reduce these downstream hawser forces. Improvements were observed, and in a further effort to minimize the water-surface differential, port extensions were removed from the first pair of downstream center ports. There was not a significant improvement in chamber performance, but the concept was considered sound. The most effective chamber design was the Type 11 which consisted of port extensions on all the downstream center ports except the first pair and the last four pairs with a 0.914-m (3-ft) wall baffle and vertical baffles under the wall baffle.

Hawser forces with the Type 11 chamber design were slightly higher than desired with the 5-min valve operation. A variable speed valve schedule developed by LRL was adopted to reduce the hawser forces with the 11.28-m (37-ft) lift. An acceptable filling time of 11.3 min was achieved with the variable valve operation. This variable valve schedule consisted of 2 min of operation with an 8-min valve opening speed and then switching to a valve speed which corresponds to a 5-min valve opening speed. This operation was continued until near the end of the cycle when the valve was decelerated to its stopping point. The prototype lock chamber will fill faster for similar operating conditions than the model indicates due to the friction differences discussed previously. The

prototype filling time is expected to be up to 10 percent faster than those measured in the model.

A roof extension was placed over the right intake to reduce the strength of the vortices that formed in the upper approach during filling operations. The Type 3 roof extension consisting of a 3.05-m- (10-ft-) wide thin plate paced at el 400 over the right intake was beneficial in reducing the strength of the vortices that formed in the upper approach during filling operations.

The computed lock coefficient determined for the Type 11 chamber design for the New McAlpine Lock during filling operations was 0.65. Table 18 provides lock coefficients determined from previous model investigations for side port and ILCS systems. These model investigations are cited in the references. The side port system developed from the Cannelton model investigation has a lock coefficient for filling of 0.74. This indicates the ILCS is slightly less efficient than the side port system, but should be much less expensive to construct. The previous McAlpine Lock model of the ILCS with the through-the-sill intakes and outlets performed slightly better than the current design. The previous design filled in 10.7 min with a 5-min valve with the 11.28-m (37-ft) lift. This is attributed to the differences in valve and intake design. Comparison of the filling curves indicated the previous design filled slower at the beginning of the filling operation than the current design and faster at the end of the filling operation. This type operation was similar to the LRL valve schedule which gave the best performance of the designs evaluated in this study.

This study confirmed many of the design features established from the ILCS investigation reported by Stockstill (1998) as follows:

- a. The port-to-culvert area ratio should be about 0.97.
- b. The port spacing in each manifold should be staggered.
- c. Two groups of ports should be centered about the one-third points of the lock length.
- d. The first upstream port should be located at 0.26, the pintle to pintle length of the chamber.
- e. Port extensions train the jets issuing from these ports in a direction normal to the longitudinal culvert.
- f. Wall baffles are beneficial because they diffuse the port jets at the lock chamber floor.
- g. Only the areas in the vicinity of the ports need to be excavated to the port invert elevation.

The ILCS design is new and therefore future field operational experience will help to fully understand the overall performance for a range of operating conditions. Some surface turbulence in the lock chamber in the vicinity of the

ports should be expected during filling with the 11.28-m (37-ft) lift. Also, vortices will form in the upper approach during filling, but should not be strong enough to draw air into the intakes if the Type 3 roof extension is adopted. The pressure data below the valves indicates that air will be drawn into the culverts if it is available. The period of low pressure is extended with single valve operations. Bulkhead slot covers are recommended to minimize the amount of air drawn into the culverts.

References

- Ables, J. H., and Boyd, M. B. (1966). "Filling and emptying system, Cannelton main lock, Ohio River, and generalized tests of sidewall port systems for 110 by 1200-ft locks: hydraulic model investigation," Technical Report 2-713, U.S. Army Engineer Waterways Experiment Station, Vicksburg, MS.
- Davis, J. P. (1989). "Hydraulic design of navigation locks," Miscellaneous Paper HL-89-5, U.S. Army Engineer Waterways Experiment Station, Vicksburg, MS.
- Fisher, H. B., List, E. J., Koh, R. C. Y., Imberger, J., and Brooks, N. H. (1979). *Mixing in Inland and Coastal Waters*, Academic Press, New York.
- Headquarters, U.S. Army Corps of Engineers. (1995a). EM 1110-2-1604, "Hydraulic design of navigation locks," Washington, DC.
- _____. (1995b). EM 1110-2-2602, "Planning and design of navigation locks," Washington, DC.
- Hite, J. E., Jr. (1999). "Model Study of Marmet Lock Filling and Emptying System, Kanawha River, West Virginia," Technical Report CHL-99-8, U.S. Army Engineer Waterways Experiment Station, Vicksburg, MS.
- Knauss, J. (1987). "Swirling flow problems at intakes," *LAHR hydraulic structures design manual*, Rotterdam, Netherlands.
- Padmanabhan, M., and Hecker, G. E. (1984). "Scale effects in pump sump models." *Journal of the Hydraulics Division*, ASCE, 110(11), 1540-1556.
- Pickett, E. B., and Neilson, F. M. (1988). "Lock hydraulic system model and prototype study data." Miscellaneous Paper HL-88-1, U.S. Army Engineer Waterways Experiment Station, Vicksburg, MS.
- Stockstill, R. L. (1998). "Innovative lock design, report 1, case study, New McAlpine Lock Filling and Emptying System, Ohio River, Kentucky," Technical Report INP-CHL-1, U.S. Army Engineer Waterways Experiment Station, Vicksburg, MS.
- Vennard, J. K., and Street, R. L. (1982). *Elementary fluid mechanics*, 6th edition, John Wiley and Sons, New York.

Table 1 Intake Vortex Experiments, Original Design, 2-Min Valve Upper Pool EI 420, Lower Pool EI 383, Left Intake			
Vortex Strength	Prototype Time, min	Vortex Strength	Prototype Time, min
Experiment No. 1		Experiment No. 4	
1	2.75	1	2.50
2	3.33	0	5.00
3	3.50	Experiment No. 5	
2	3.75	1	2.92
1	5.00	0	7.50
0	7.50	Experiment No. 6	
Experiment No. 2		1	2.92
1	2.75	2	3.75
2	3.08	1	4.33
3	3.33	2	6.67
4	3.42	1	6.92
3	3.58	0	7.50
2	4.17		
1	5.42		
0	6.25		
Experiment No. 3			
1	2.92		
2	3.33		
1	3.75		
2	4.17		
3	4.33		
4	4.42		
5	4.50		
2	4.58		
1	5.00		
0	7.50		
Note: 0 strength indicates no vortex activity			

Table 2
Intake Vortex Experiments, Original Design, 2-Min Valve
Upper Pool EI 420, Lower Pool EI 383, Right Intake

Vortex Strength	Prototype Time, min	Vortex Strength	Prototype Time, min
Experiment No. 1		Experiment No. 4	
4	3.75	1	2.08
1	4.12	1	4.58
1	4.42	2	4.75
2	4.58	3	5.08
4	5.00	2	6.25
1	5.33	5	7.08
2	5.42	1	7.5
1	6.00	0	8.75
4	6.67	Experiment No. 5	
Experiment No. 2		1	2.50
1	2.50	2	5.00
1	5.00	5	5.83
3	5.42	2	6.25
1	5.83	Experiment No. 6	
4	6.25	1	3.17
1	7.5	2	3.58
Experiment No. 3		0	3.92
1	2.92	4	5.00
4	3.33	5	5.67
2	6.17		
1	6.33		

Note: 0 strength indicates no vortex activity

Table 3
Intake Vortex Experiments, Original Design, 4-Min Valve
Upper Pool EI 420, Lower Pool EI 383, Left Intake

Vortex Strength	Prototype Time, min	Vortex Strength	Prototype Time, min
Experiment No. 1		Experiment No. 4	
1	2.92	1	2.50
2	3.00	2	3.33
3	3.08	1	3.58
4	3.17	0	6.25
5	3.25	Experiment No. 5	
6	3.33	1	2.92
1	3.58	0	4.58
0	7.50	1	5.42
Experiment No.2		0	7.50
1	2.75	Experiment No. 6	
2	3.75	1	2.75
1	5.00	0	3.33
0	5.42	1	4.58
Experiment No. 3		0	8.33
1	2.83		
2	3.33		
1	5.42		
0	6.25		
Note: 0 strength indicates no vortex activity			

Table 4
Intake Vortex Experiments, Original Design, 4-Min Valve
Upper Pool EI 420, Lower Pool EI 383, Right Intake

Vortex Strength	Prototype Time, min	Vortex Strength	Prototype Time, min
Experiment No. 1		Experiment No. 4	
5	5.83	2	2.50
4	6.25	1	2.75
3	7.08	2	5
2	7.33	2	5.42
2	8.33	5	5.83
Experiment No.2		1	6.67
1	2.08	1	9.17
0	2.25	Experiment No. 5	
1	3.58	1	3.75
0	3.75	5	4.58
1	4.58	1	5.00
2	5.00	0	5.83
0	5.25	1	7.08
1	7.92	Experiment No. 6	
Experiment No. 3		1	3.33
1	1.67	4	4.17
2	4.17	1	5.25
5	5.00	2	5.83
1	5.83	1	7.08
2	7.50		
1	9.17		
0	9.58		

Note: 0 strength indicates no vortex activity

Table 5
Intake Vortex Experiments, Original Design, 8-Min Valve
Upper Pool EI 420, Lower Pool EI 383, Left Intake

Vortex Strength	Prototype Time, min	Vortex Strength	Prototype Time, min
Experiment No. 1		Experiment No. 4	
1	5.83	1	5.00
0	10.00	2	10.42
Experiment No.2		1	10.83
1	4.58	0	11.25
0	5.83	Experiment No. 5	
1	6.25	1	5.42
0	8.33	0	12.92
1	9.17	Experiment No. 6	
0	10.00	1	5.00
Experiment No. 3		0	8.75
1	5.83	1	9.58
0	6.67	2	10.00
1	10	1	10.25
1	10.83	0	11.25
0	11.25		
Note: 0 strength indicates no vortex activity			

Table 6
Intake Vortex Experiments, Original Design, 8-Min Valve
Upper Pool EI 420, Lower Pool EI 383, Right Intake

Vortex Strength	Prototype Time, min	Vortex Strength	Prototype Time, min
Experiment No. 1		Experiment No. 4	
1	7.50	2	5.00
2	7.92	1	9.17
0	8.33	1	10
1	9.58	2	10.42
1	10.00	Experiment No. 5	
Experiment No.2		1	6.67
1	5.42	2	7.08
1	7.08	1	7.25
2	8.33	0	7.50
2	9.17	2	8.75
1	9.58	0	10.00
Experiment No. 3		1	11.25
1	3.75	Experiment No. 6	
2	9.58	1	4.58
2	10.00	2	5.25
		0	5.58
		2	7.92
		5	8.75
Note: 0 strength indicates no vortex activity			

Table 7
Intake Vortex Experiments, Type 2 Design Roof Extension, 4-Min
Valve, Upper Pool El 420, Lower Pool El 383, Left Intake

Vortex Strength	Prototype Time, min	Vortex Strength	Prototype Time, min
Experiment No. 1		Experiment No. 4	
1	5.42	1	8.75
2	9.00	0	12.50
1	10.00	Experiment No. 5	
0	10.83	1	8.33
Experiment No. 2		2	8.75
1	6.67	1	9.00
2	7.92	0	11.25
1	8.75	Experiment No. 6	
0	9.56	1	7.92
Experiment No. 3		2	8.58
1	8.33	1	9.00
2	9.17	0	11.25
1	9.58		
0	11.25		

Note: 0 strength indicates no vortex activity

Table 8
Intake Vortex Experiments, Type 2 Design Roof Extension, 4-MIn
Valve, Upper Pool EI 420, Lower Pool EI 383, Right Intake

Vortex Strength	Prototype Time, min	Vortex Strength	Prototype Time, min
Experiment No. 1		Experiment No. 4	
1	4.58	1	4.58
0	10.00	2	9.58
Experiment No. 2		1	10.00
1	3.75	0	17.50
2	4.17	Experiment No. 5	
1	4.58	1	4.58
0	10.83	2	10.42
Experiment No. 3		1	10.83
1	4.17	0	16.67
2	8.75	Experiment No. 6	
3	9.17	1	5.00
2	9.58	2	8.75
1	10.00	3	9.00
2	10.83	2	9.17
0	16.67	1	10.42
		0	16.67
<p>Note: 0 strength indicates no vortex activity</p>			

Table 9
Intake Vortex Experiments, Type 2 Design Roof Extension, 8-Min
Valve, Upper Pool EI 420, Lower Pool EI 383, Left Intake

Vortex Strength	Prototype Time, min	Vortex Strength	Prototype Time, min
Experiment No. 1		Experiment No. 4	
1	9.58	1	9.58
2	10.00	2	10.00
1	11.25	1	16.67
0	19.17	0	20.42
Experiment No. 2		Experiment No. 5	
1	8.75	1	10.42
2	9.17	2	10.83
3	9.58	1	12.08
2	9.83	0	19.58
3	11.92	Experiment No. 6	
4	12.08	1	9.58
3	12.33	2	10.00
2	12.50	1	12.08
1	16.67	2	16.67
0	17.92	1	17.50
Experiment No. 3		0	18.75
1	9.17		
2	9.58		
3	11.25		
2	12.08		
1	12.50		
0	20.00		

Note: 0 strength indicates no vortex activity

Table 10
Intake Vortex Experiments, Type 2 Design Roof Extension, 8-Min
Valve, Upper Pool EI 420, Lower Pool EI 383, Right Intake

Vortex Strength	Prototype Time, min	Vortex Strength	Prototype Time, min
Experiment No. 1		Experiment No. 4	
1	17.08	No Vortex	
0	19.17		
Experiment No.2		Experiment No. 5	
1	17.92	No Vortex	
0	20.00		
Experiment No. 3		Experiment No. 6	
No Vortex		1	18.33
		0	19.58
Note: 0 strength indicates no vortex activity			

Table 11
Intake Vortex Experiments, Type 3 Design Roof Extension, 4-Min
Valve, Upper Pool EI 420, Lower Pool EI 383, Left Intake

Vortex Strength	Prototype Time, min	Vortex Strength	Prototype Time, min
Experiment No. 1		Experiment No. 4	
1	4.17	1	4.17
2	8.75	0	8.75
1	9.58	Experiment No. 5	
0	17.08	1	4.17
Experiment No. 2		2	4.58
1	4.58	1	5.00
2	5.42	2	8.75
1	9.17	1	9.17
0	16.67	0	9.58
Experiment No. 3		Experiment No. 6	
1	4.17	1	4.58
2	5.00	0	16.67
1	8.75		
0	12.50		
Note: 0 strength indicates no vortex activity			

Table 12
Intake Vortex Experiments, Type 3 Design Roof Extension, 4-Min
Valve, Upper Pool EI 420, Lower Pool EI 383, Right Intake

Vortex Strength	Prototype Time, min	Vortex Strength	Prototype Time, min
Experiment No. 1		Experiment No. 4	
1	11.25	1	10.42
2	11.67	2	10.83
1	12.50	1	11.25
0	17.08	0	16.67
Experiment No. 2		Experiment No. 5	
1	11.67	1	11.25
2	12.08	2	11.67
1	12.92	1	12.50
0	16.67	0	17.50
Experiment No. 3		Experiment No. 6	
1	11.25	No Vortex	
2	11.67		
1	12.08		
0	17.50		
Note: 0 strength indicates no vortex activity			

Table 13
Intake Vortex Experiments, Type 3 Design Roof Extension, 5-Min
Valve, Upper Pool EI 420, Lower Pool EI 383, Left Intake

Vortex Strength	Prototype Time, min	Vortex Strength	Prototype Time, min
Experiment No. 1		Experiment No. 4	
1	9.17	1	8.33
0	10.83	0	10.00
Experiment No.2		Experiment No. 5	
1	8.33	1	8.33
0	9.58	0	12.08
Experiment No. 3		Experiment No. 6	
1	4.17	1	8.33
2	4.58	0	12.50
1	8.75		
0	16.67		
Note: 0 strength indicates no vortex activity			

**Table 14
Intake Vortex Experiments, Type 3 Design Roof Extension, 5-Min
Valve, Upper Pool EI 420, Lower Pool EI 383, Right Intake**

Vortex Strength	Prototype Time, min	Vortex Strength	Prototype Time, min
Experiment No. 1		Experiment No. 4	
1	11.67	1	11.25
2	12.08	0	12.92
1	12.92	Experiment No. 5	
0	18.33	1	11.67
Experiment No.2		2	12.08
1	11.67	1	17.08
2	12.08	0	18.33
1	12.50	Experiment No. 6	
0	12.92	1	12.08
Experiment No. 3		0	17.92
1	12.08		
2	17.08		
1	17.50		
0	19.17		
Note: 0 strength indicates no vortex activity			

Table 15
Intake Vortex Experiments, Type 3 Design Roof Extension, 8-Min
Valve, Upper Pool EI 420, Lower Pool EI 383, Left Intake

Vortex Strength	Prototype Time, min	Vortex Strength	Prototype Time, min
Experiment No. 1		Experiment No. 4	
1	10.00	1	8.75
2	11.25	0	9.58
1	12.08	1	10.42
0	16.67	0	18.75
Experiment No.2		Experiment No. 5	
1	10.83	1	10.00
0	11.67	2	12.08
1	12.92	1	12.33
0	16.67	0	19.17
Experiment No. 3		Experiment No. 6	
1	17.50	1	9.58
0	17.92	2	10.83
		1	11.25
		0	19.17
<p>Note: 0 strength indicates no vortex activity</p>			

Table 16
Intake Vortex Experiments, Type 3 Design Roof Extension, 8-Min
Valve, Upper Pool EI 420, Lower Pool EI 383, Right Intake

Vortex Strength	Prototype Time, min	Vortex Strength	Prototype Time, min
Experiment No. 1		Experiment No. 4	
1	17.08	1	11.67
0	17.92	0	12.50
Experiment No.2		1	16.67
1	16.67	0	18.75
0	17.50	Experiment No. 5	
Experiment No. 3		1	17.08
1	9.58	0	19.17
2	10	Experiment No. 6	
1	10.83	1	17.08
0	16.67	0	17.92
Note: 0 strength indicates no vortex activity			

Table 17
Filling Characteristics for Range of Operating Conditions, Type 11 Chamber Design

Lift ft	Lower Pool el	Upper Pool el	Valve Time min	Filling Time min	Maximum Hawser Forces											
					Longitudinal				Upstream Transverse				Downstream Transverse			
					Upstream		Downstream		Left		Right		Left		Right	
					Force tons	Time min	Force tons	Time min	Force tons	Time min	Force tons	Time min	Force tons	Time min	Force tons	Time min
30	388	418	8	11.8	2.2	1.9	4.2	0.6	2.0	9.3	2.2	7.5	2.1	7.5	2.0	5.8
30	388	418	5	10.3	3.7	1.8	6.0	0.6	3.4	4.8	3.6	4.5	4.3	5.6	3.0	4.4
30	388	418	4	9.8	5.6	1.8	7.5	0.6	3.4	3.8	4.2	4.8	5.3	4.2	2.8	4.8
30	383	413	8	11.6	2.7	1.8	4.4	0.6	2.6	8.5	1.7	6.0	3.2	7.8	2.0	7.1
30	383	413	4	9.5	4.8	1.8	9.1	0.7	4.9	5.0	4.7	4.7	5.3	4.9	4.3	5.3
30	383	413	2	8.4	6.3	3.0	18.2	0.7	4.9	3.0	4.1	3.6	6.3	2.5	3.5	5.0
37	383	420	8	12.3	2.4	2.0	4.8	0.8	3.2	8.9	3.2	6.8	3.8	7.3	2.8	4.2
37	383	420	5	10.8	5.4	5.2	7.5	0.8	4.1	5.2	3.3	3.5	5.1	6.2	2.9	3.2
37	383	420	4	10.2	7.5	3.5	9.1	0.7	4.3	5.5	5.3	4.0	6.7	5.0	4.2	3.8

Note: To convert feet to meters, multiply by 0.3048. To convert tons to newtons, multiply by 8896.443.

**Table 18
Lock Coefficients Determined from Model Studies**

Project	Initial Head ft	Overall Lock Coefficient	
		Filling	Emptying
Cannelton Model Type 45 Port Arrangement Side Port	20	0.74	0.57
	26	0.74	0.60
	30	0.73	0.61
	40	0.74	0.60
Cannelton Model Type 100 Port Arrangement Side Port	20	0.71	0.56
	30	0.73	0.56
	40	0.74	0.56
Arkansas River Model	10-50	0.73	0.67
Marmet Model Type 5 Design ILCS	14	0.63	
	24	0.63	
	34	0.63	
McAlpine Model Type 11 Design ILCS	37	0.65	0.57
McAlpine Model Type 1 Design ILCS	37	0.63	0.56

Note: To convert feet to meters, multiply by 0.3048.



Photo 1. Confetti illustrating surface currents within the lock chamber as filling started

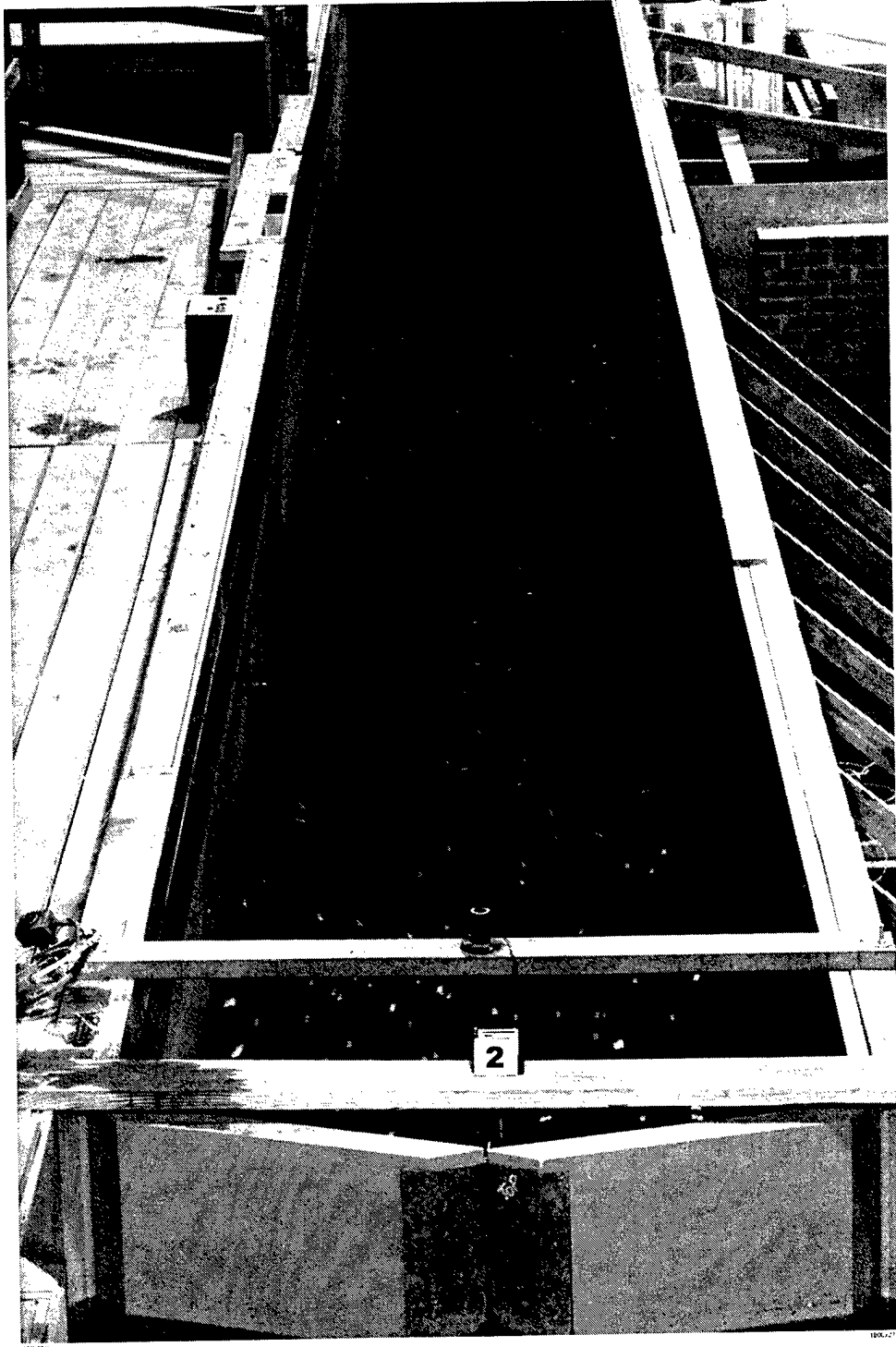

Photo 2. Confetti illustrating surface currents within the lock chamber 2 min after filling started

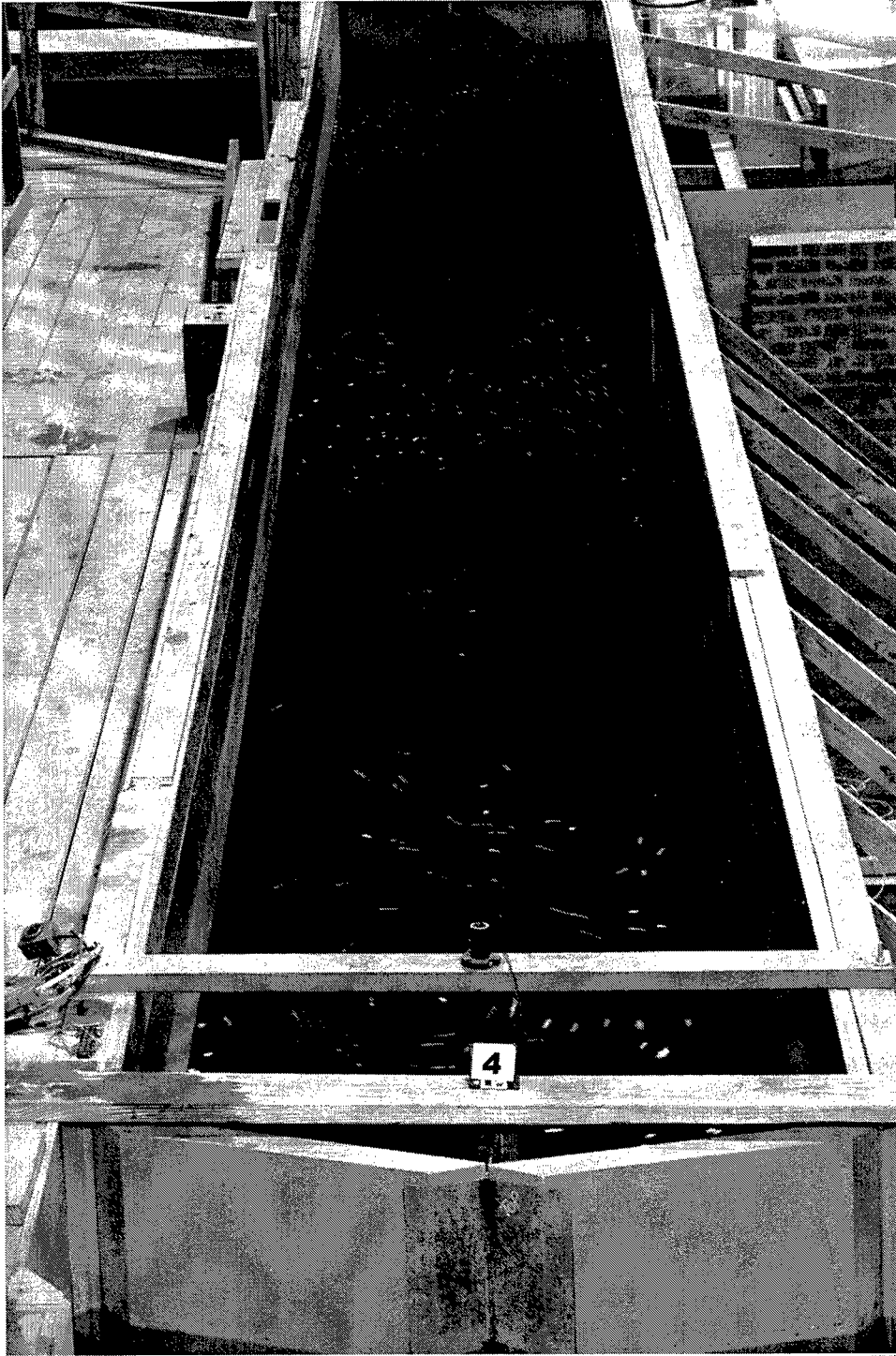

Photo 3. Confetti illustrating surface currents within the lock chamber 4 min after filling started

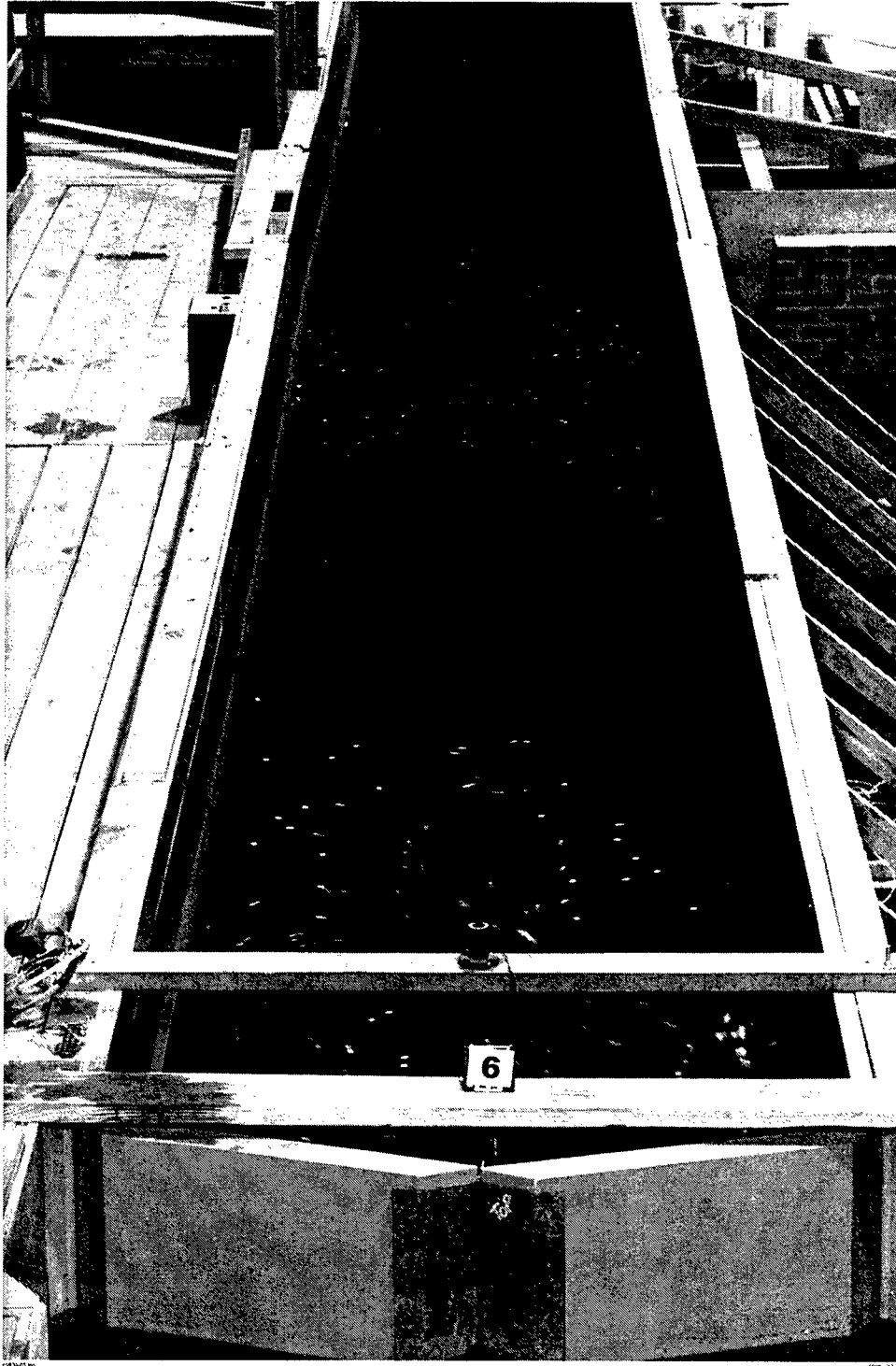

Photo 4. Confetti illustrating surface currents within the lock chamber 6 min after filling started

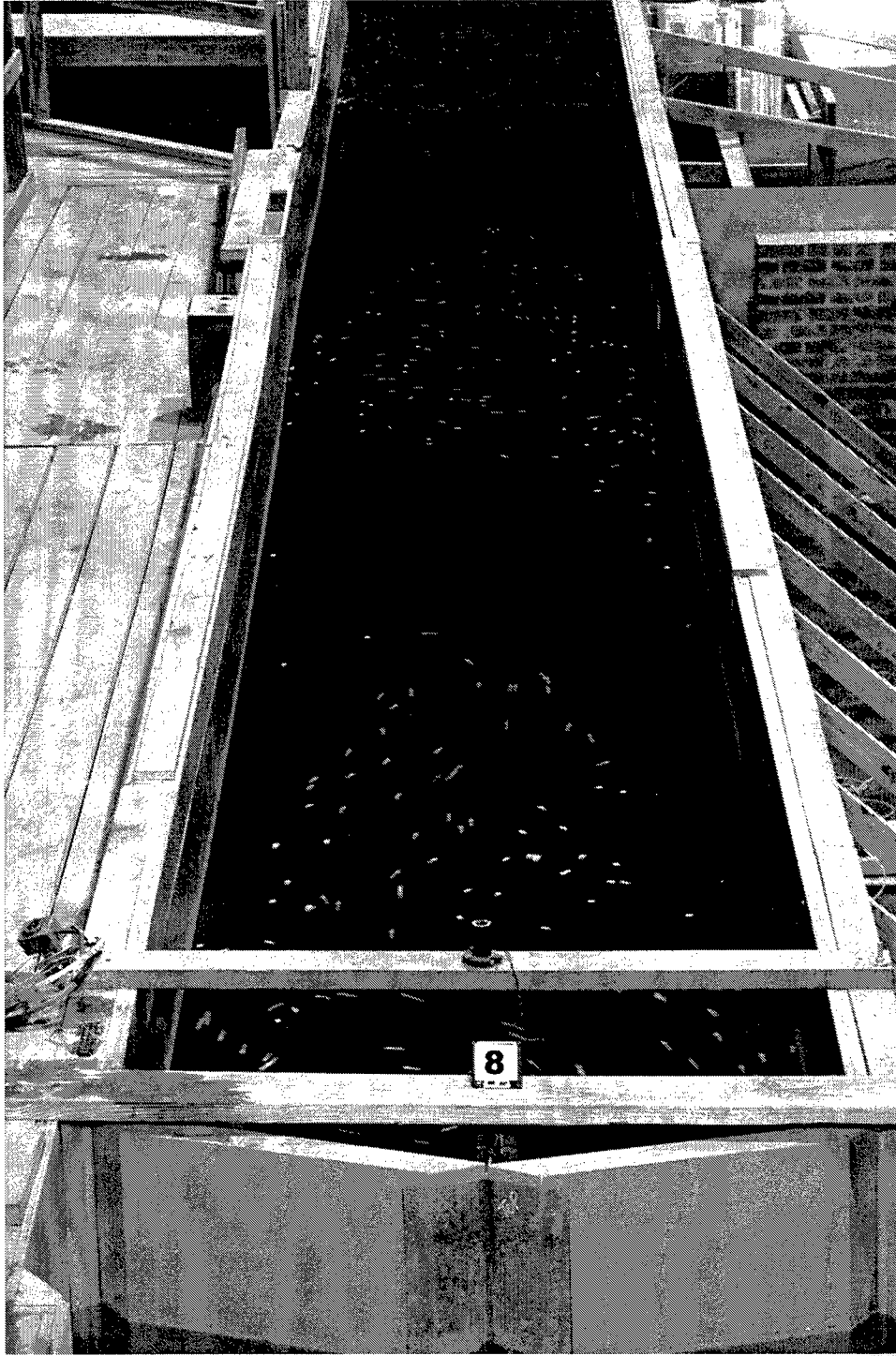
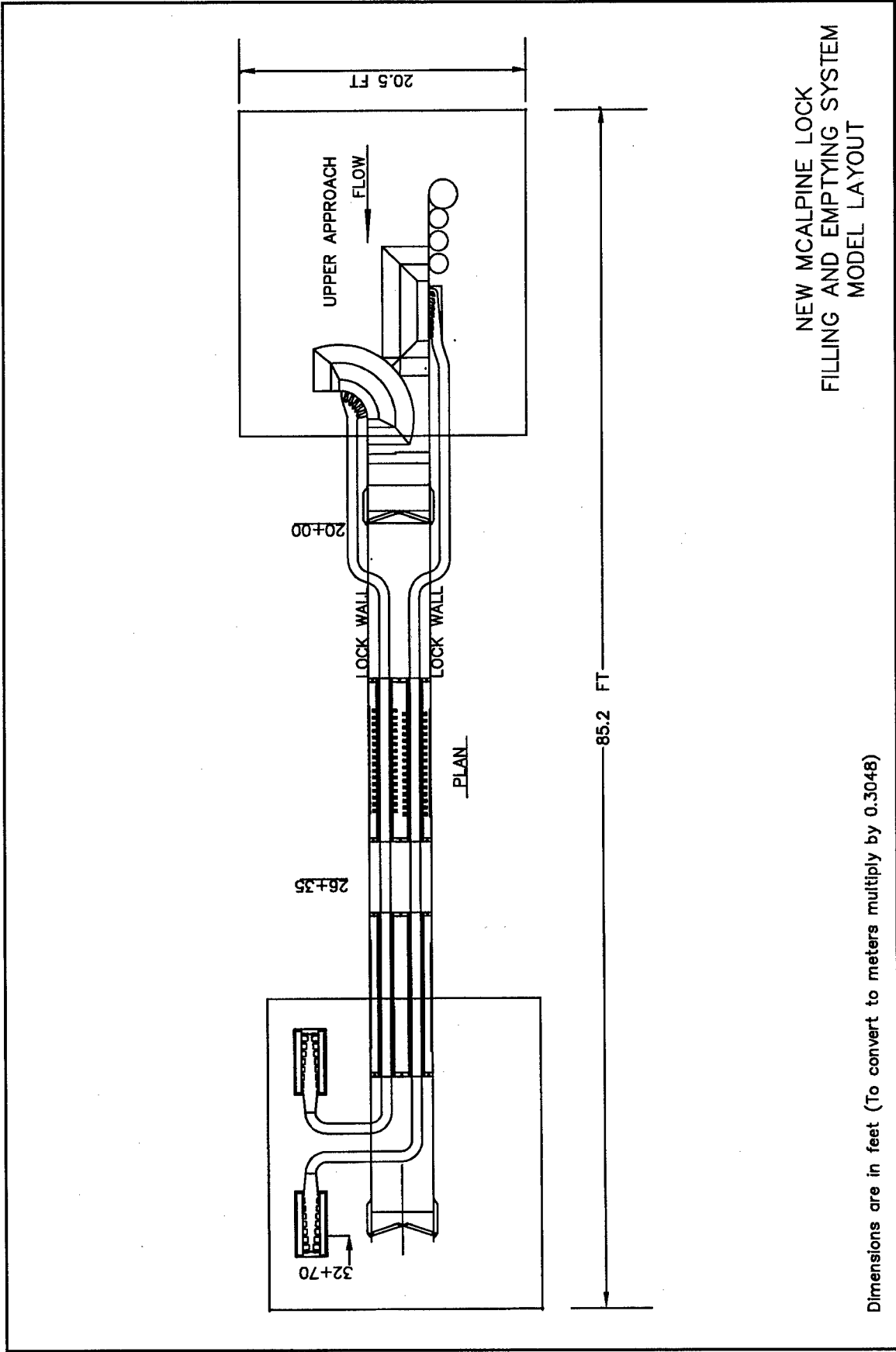

Photo 5. Confetti illustrating surface currents within the lock chamber 8 min after filling started

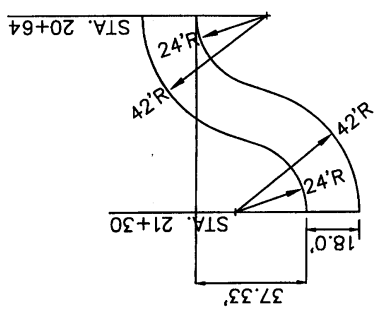
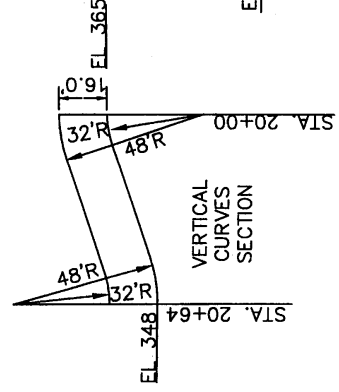
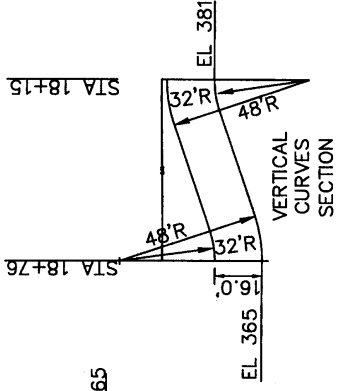
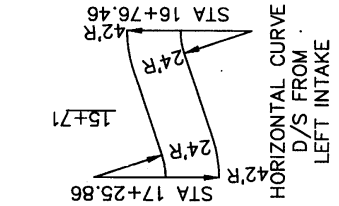

Photo 6. Confetti illustrating surface currents within the lock chamber 10 min after filling started



NEW MCALPINE LOCK
FILLING AND EMPTYING SYSTEM
MODEL LAYOUT

Dimensions are in feet (To convert to meters multiply by 0.3048)



U/S HORIZONTAL CURVES PLAN

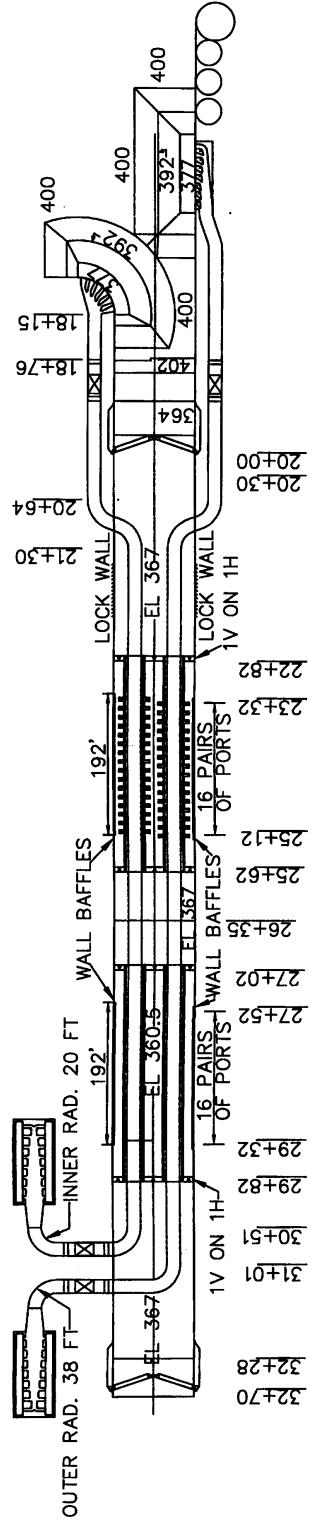

All elevations (el) are in feet referenced to the National Geodetic Vertical Datum (NGVD) (to convert to meters, multiply number of feet by 0.3048).

NEW MCALPINE LOCK
TYPE 1 FILLING AND EMPTYING SYSTEM

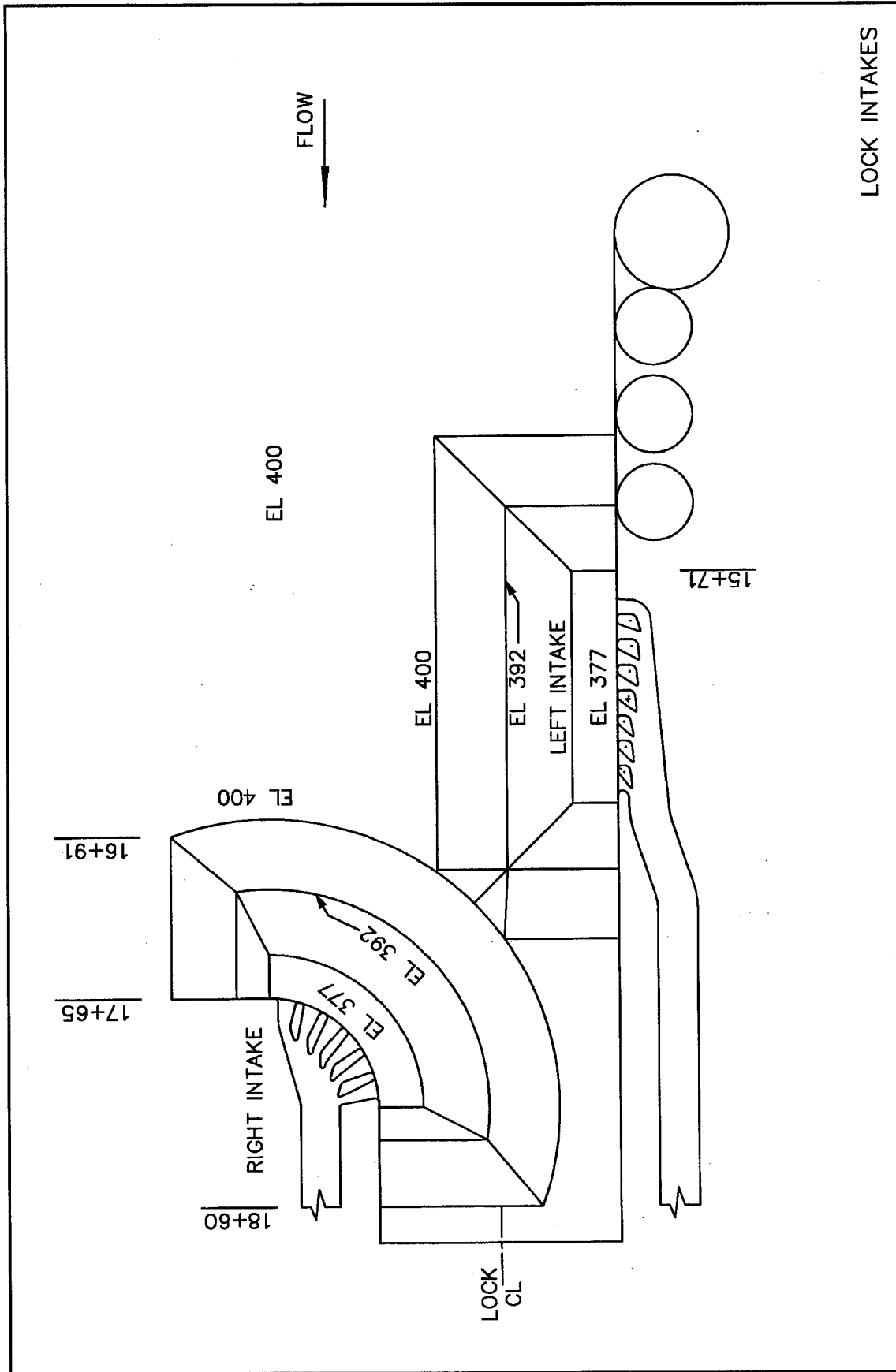

LOCK INTAKES

Plate 3

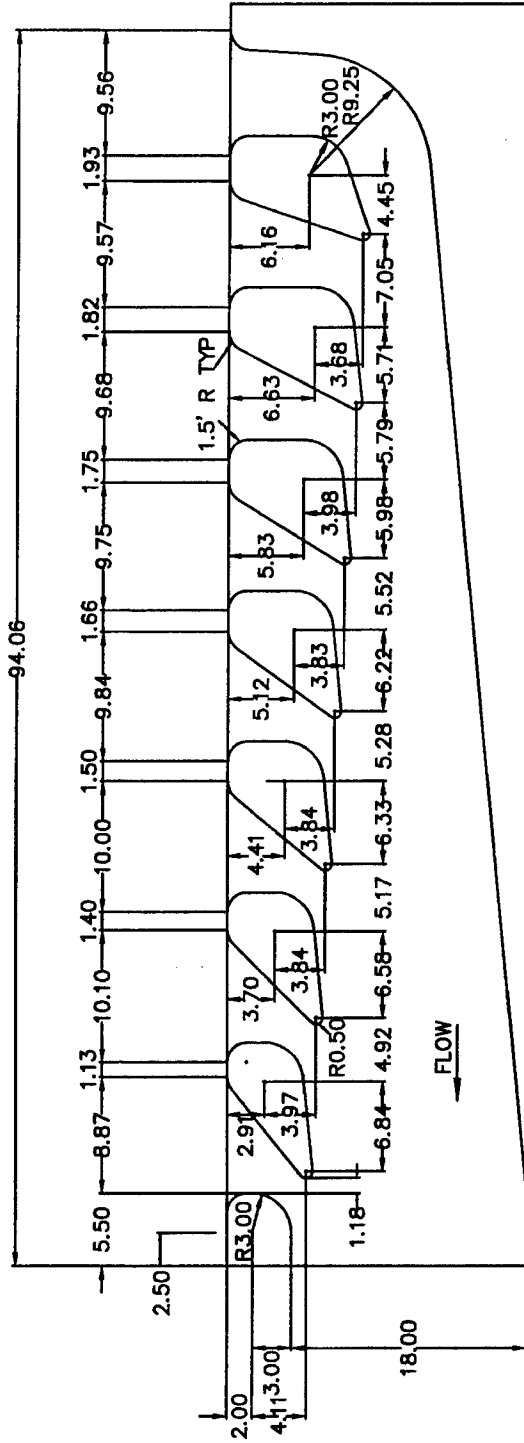
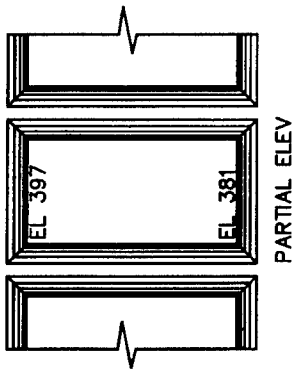

NOTE: DIMENSIONS ARE IN FT
(TO CONVERT TO METERS MULTIPLY BY 0.3048)

DETAILS OF LEFT INTAKE

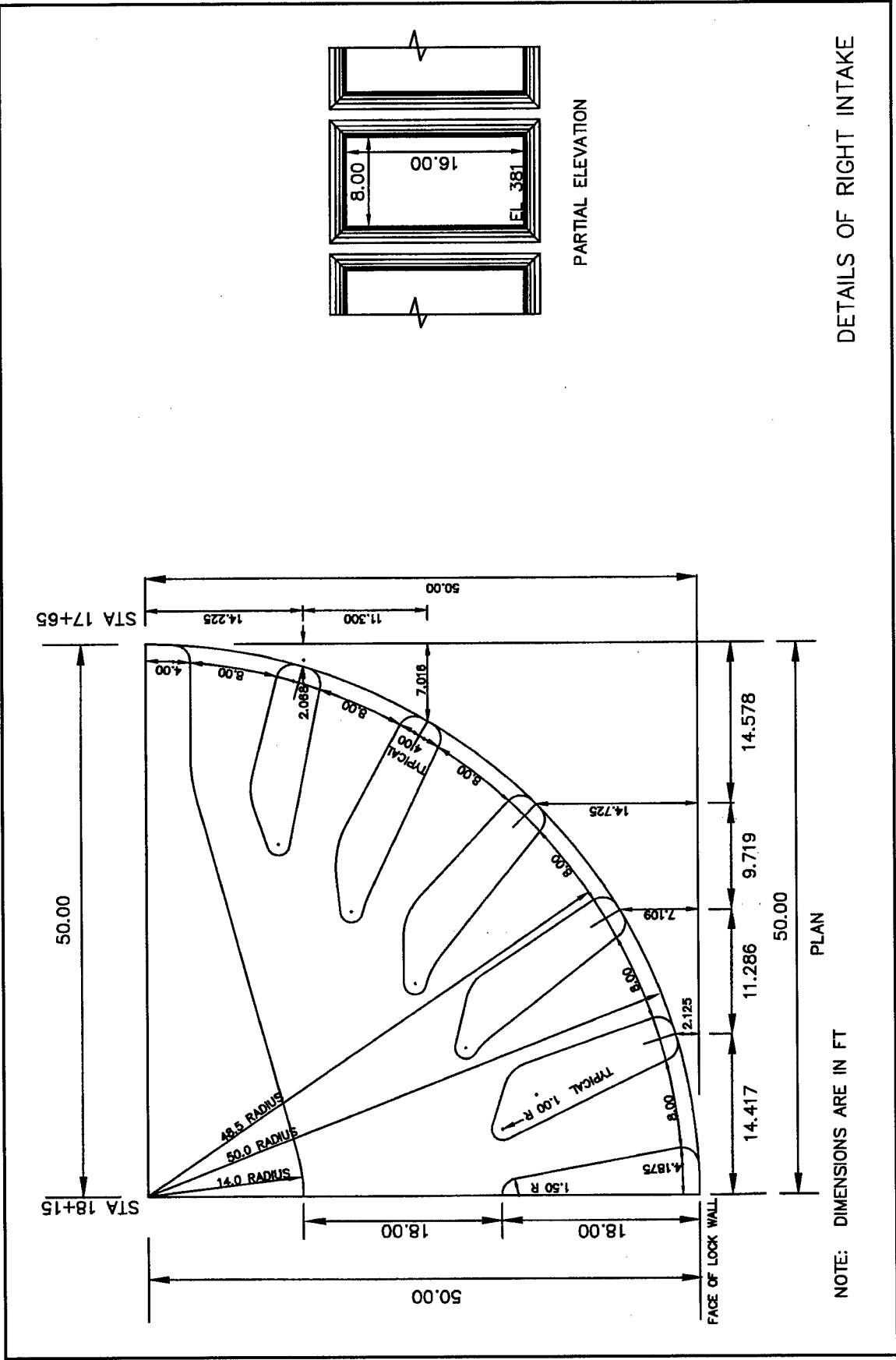

DETAILS OF RIGHT INTAKE

NOTE: DIMENSIONS ARE IN FT

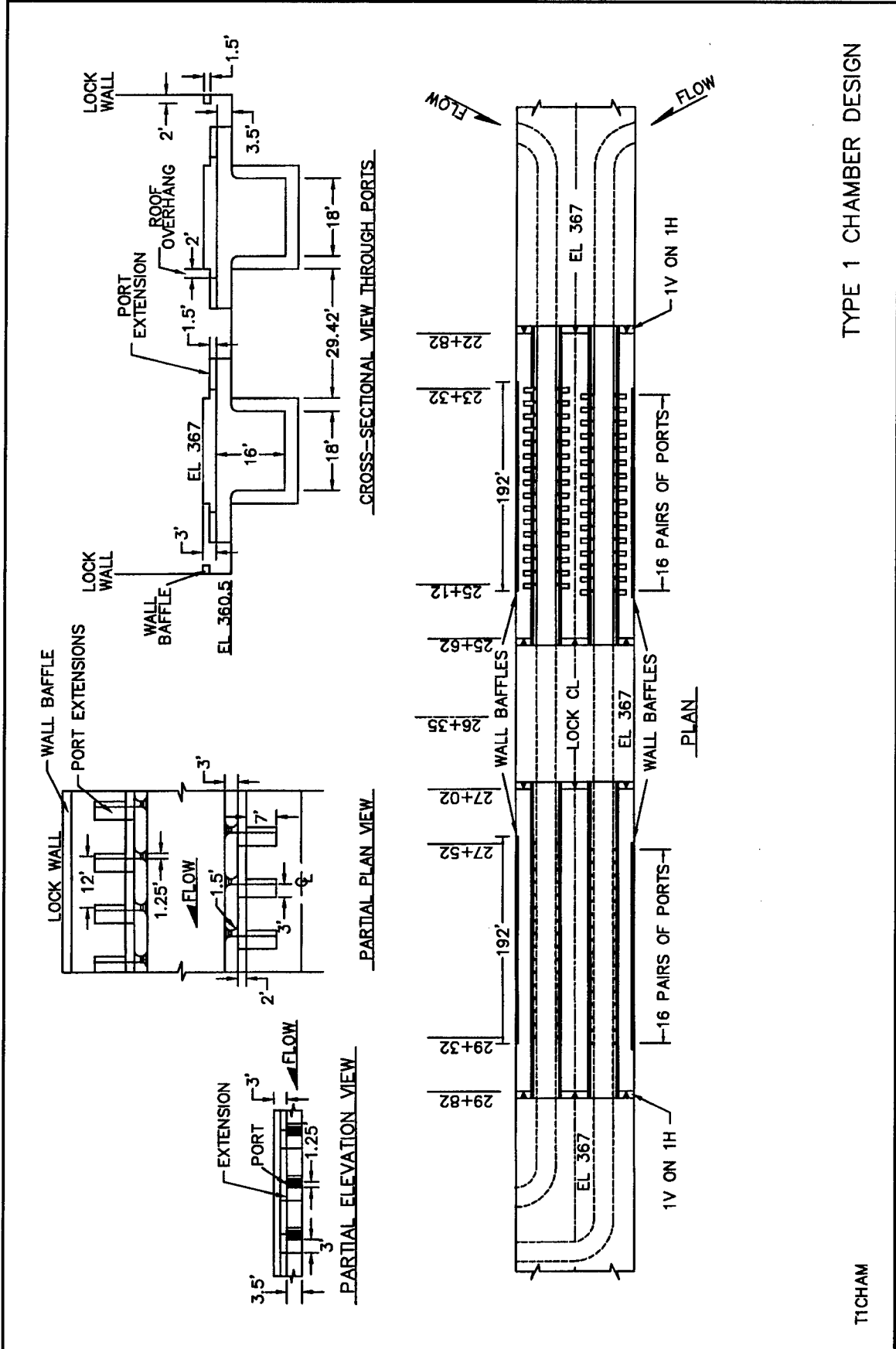

TYPE 1 CHAMBER DESIGN

TICHAM

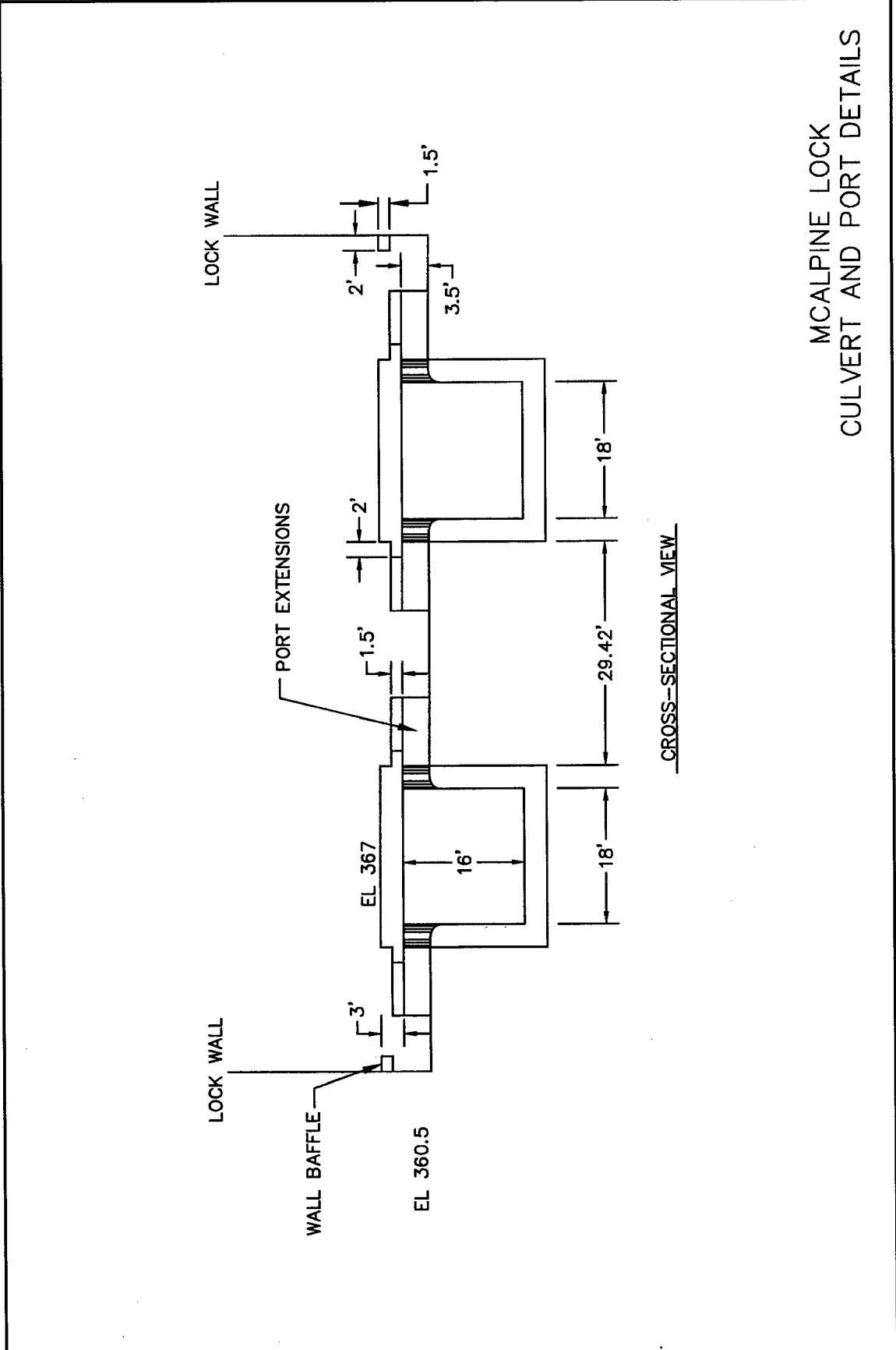

MCALPINE LOCK
CULVERT AND PORT DETAILS

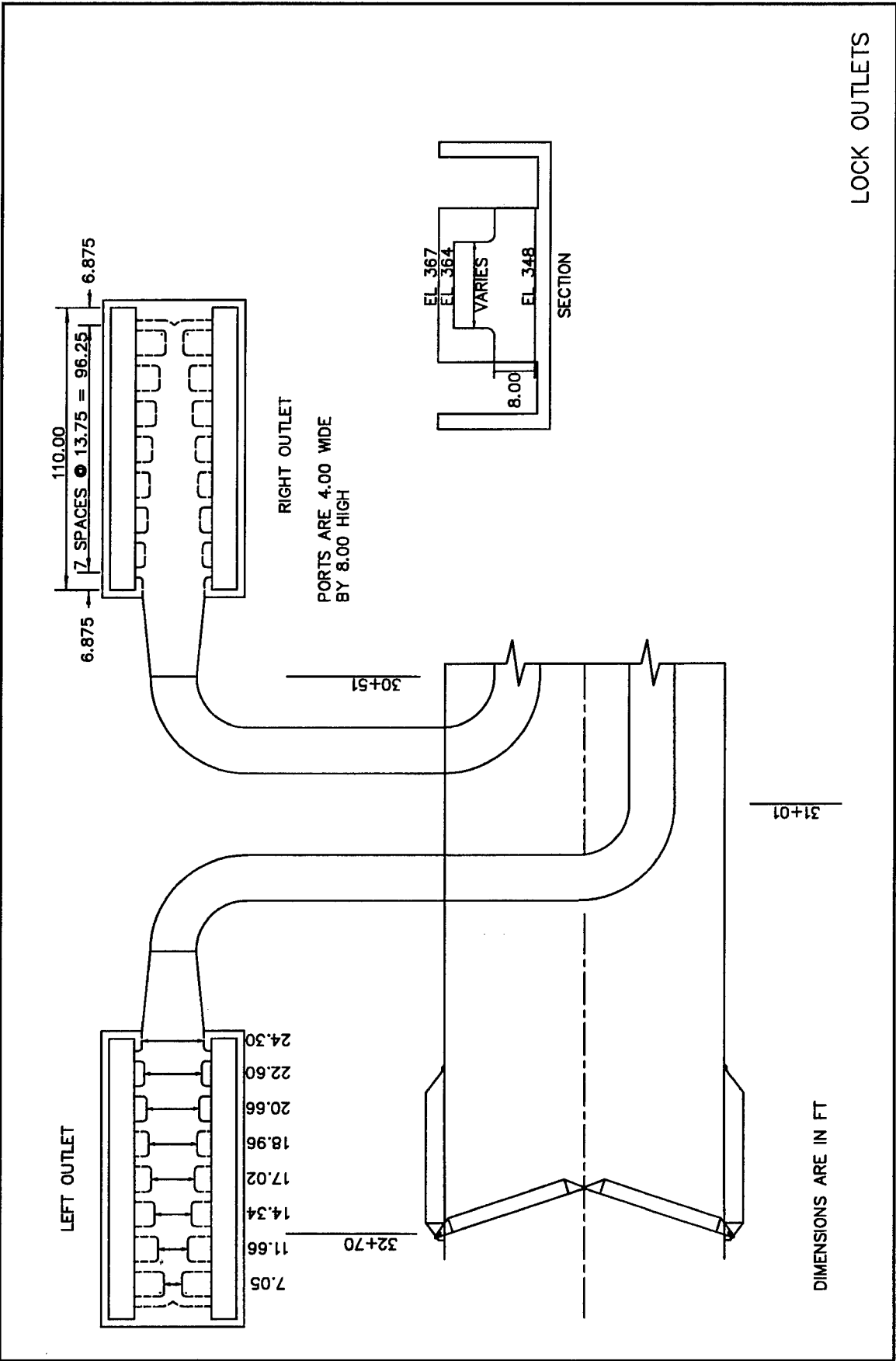
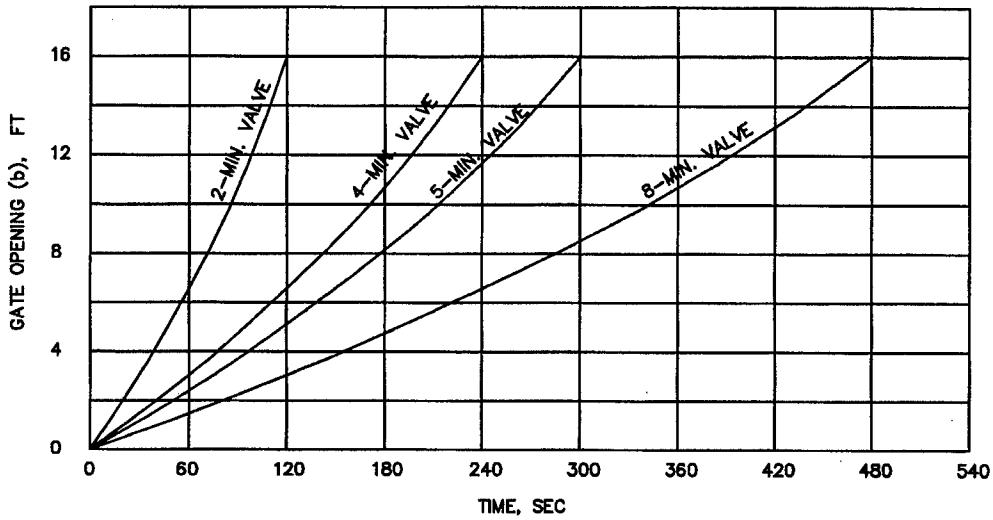
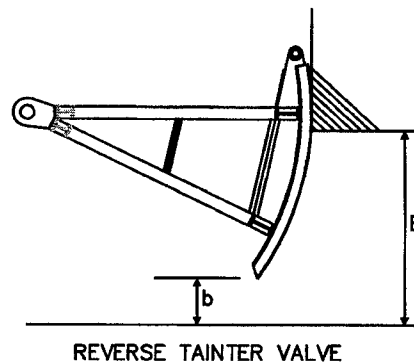
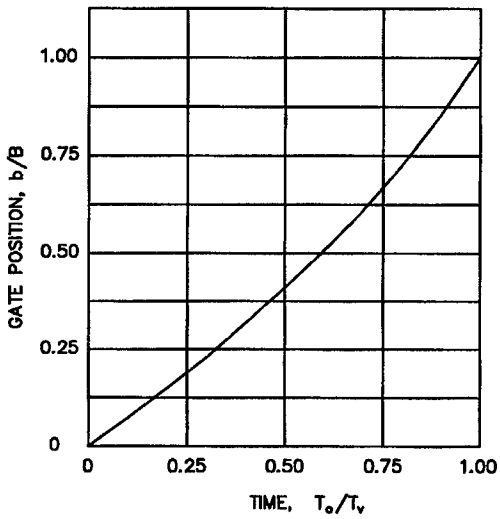

Plate 8



b/B	T_o/T_v
0	0
0.073	0.10
0.150	0.20
0.230	0.30
0.317	0.40
0.410	0.50
0.506	0.60
0.611	0.70
0.727	0.80
0.854	0.90
1.000	1.00



T_o = TIME SINCE OPENING BEGAN

T_v = TIME TO OPEN FULL

B = 16 FT

b = VERTICAL DIST. FROM LIP TO FLOOR

TYPE 1 DESIGN
VALVE OPENING CURVES

GOVST

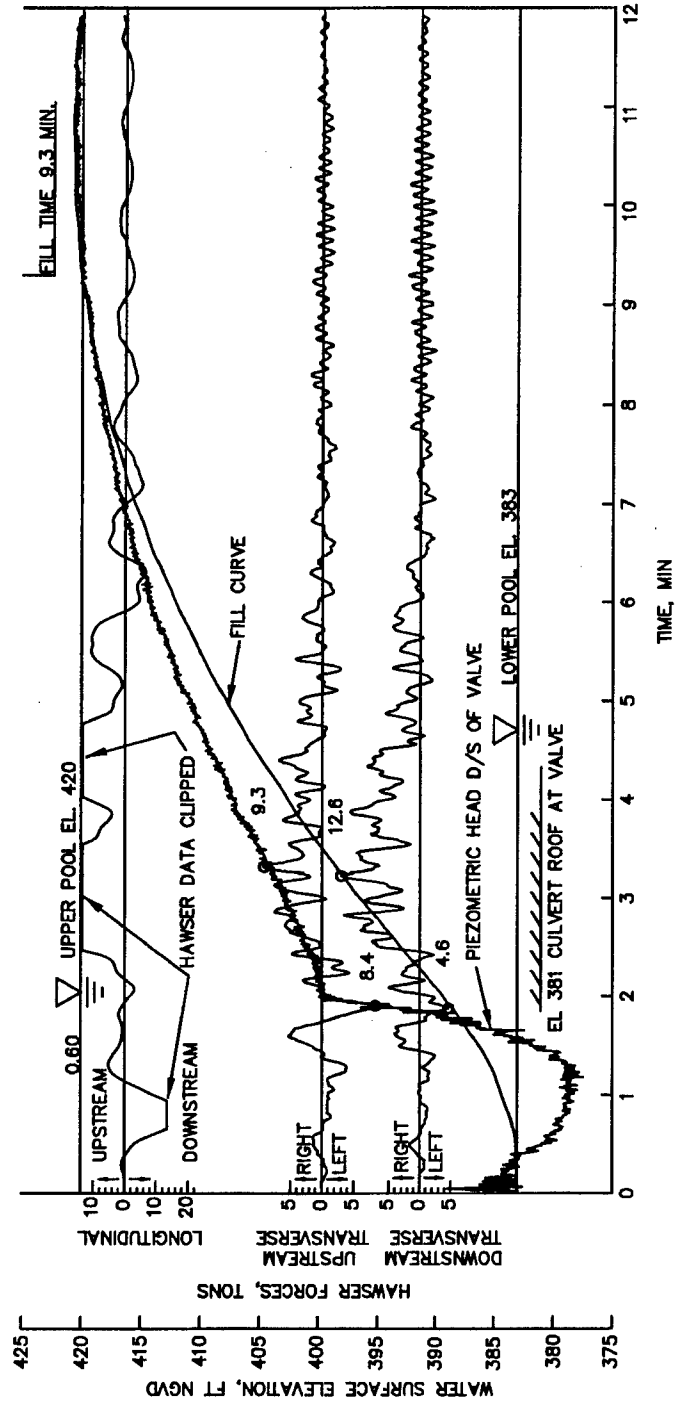

Hawser force is in tons. To convert to newtons multiply by 8,896.443.

FILLING CHARACTERISTICS
 ORIGINAL DESIGN
 2- MIN. NORMAL FILL - TEST 2

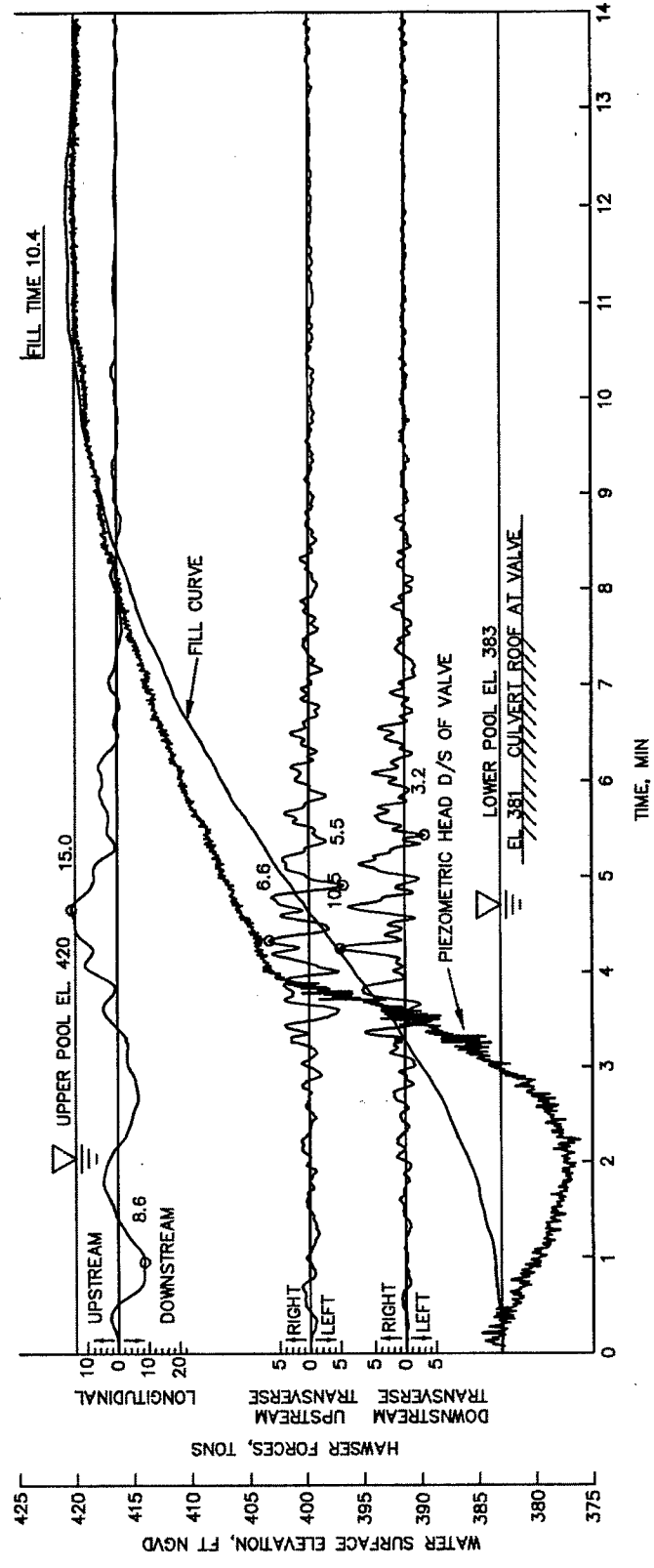

FILLING CHARACTERISTICS
 ORIGINAL DESIGN
 4 - MIN NORMAL FILL - TEST 3

MAC4F.003

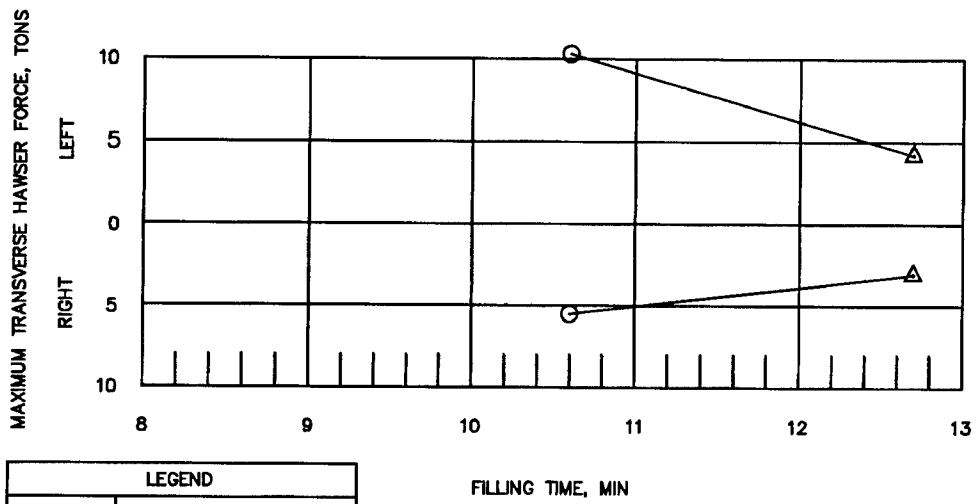
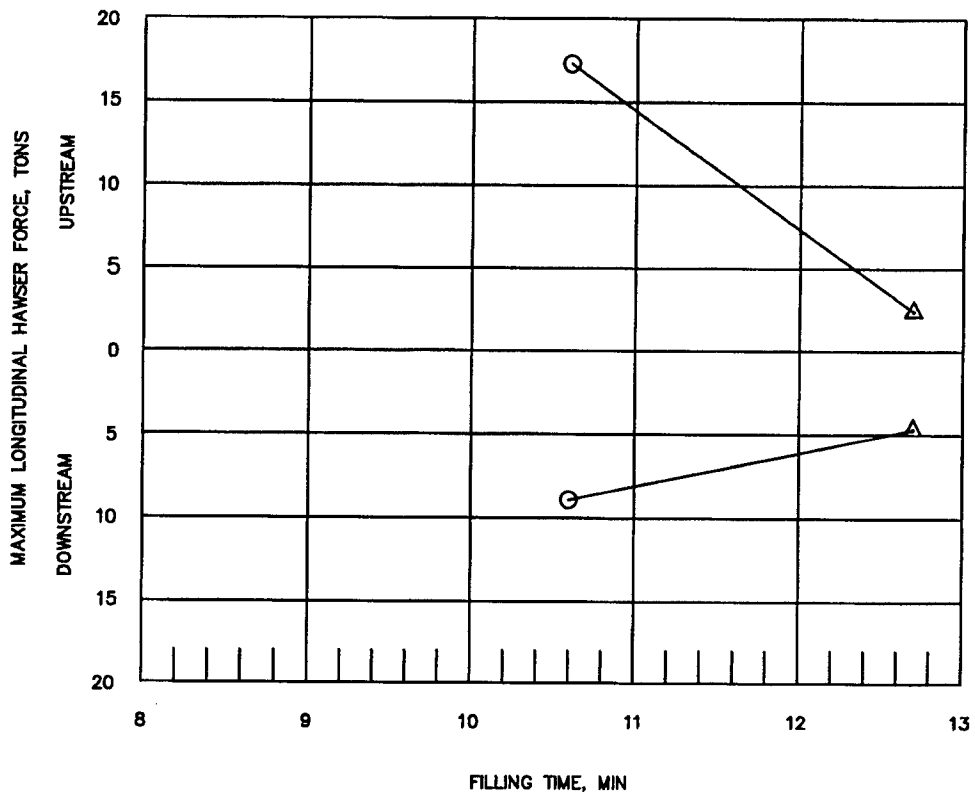

LEGEND	
○	VALVE SCHEDULE, MIN 4
□	5
△	8
—	DESIGN TYPE 1

HAWSER FORCES
DURING FILLING
TYPE 1 DESIGN

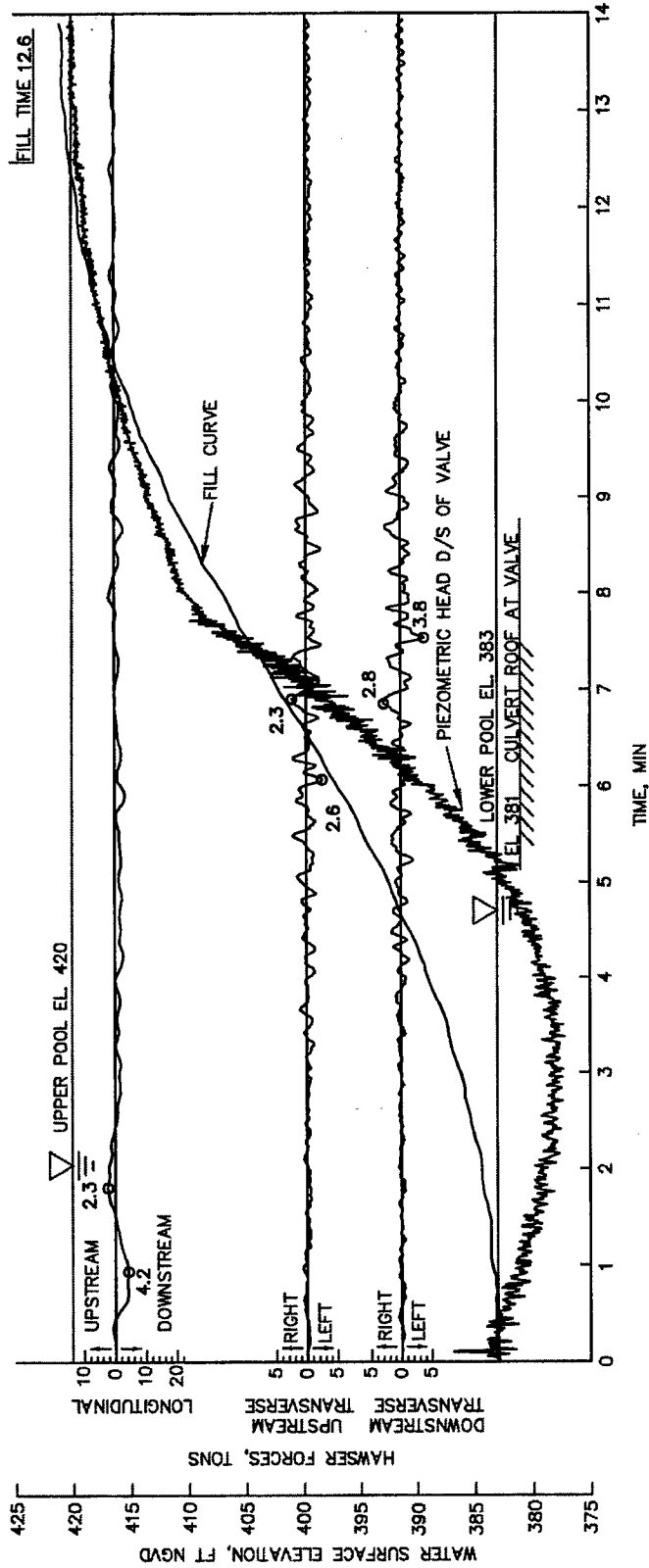

FILLING CHARACTERISTICS
 ORIGINAL DESIGN
 8 - MIN NORMAL FILL - TEST 1

MACRF.001

VORTEX
TYPE (VT)

1



COHERENT SURFACE SWIRL

2



SURFACE DIMPLE
COHERENT SWIRL AT SURFACE

3

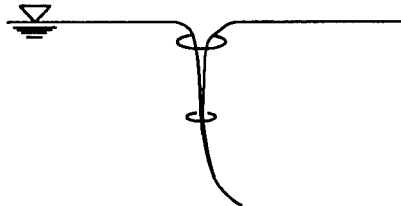

DYE CORE TO INTAKE
COHERENT SWIRL THROUGHOUT
WATER COLUMN

4

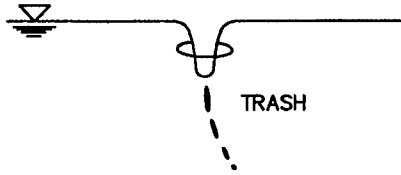

VORTEX PULLING FLOATING
TRASH, BUT NOT AIR

5

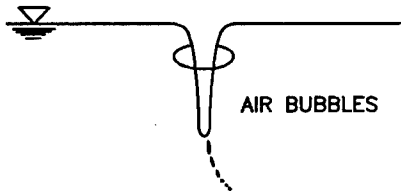

VORTEX PULLING AIR
BUBBLES TO INTAKE

6

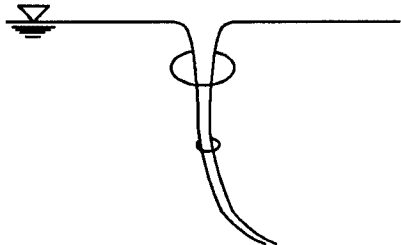

FULL AIR CORE
TO INTAKE

SOURCE: PADMANABHAN AND HECKER, 1984

ALDEN RESEARCH LAB
VORTEX TYPE CLASSIFICATION

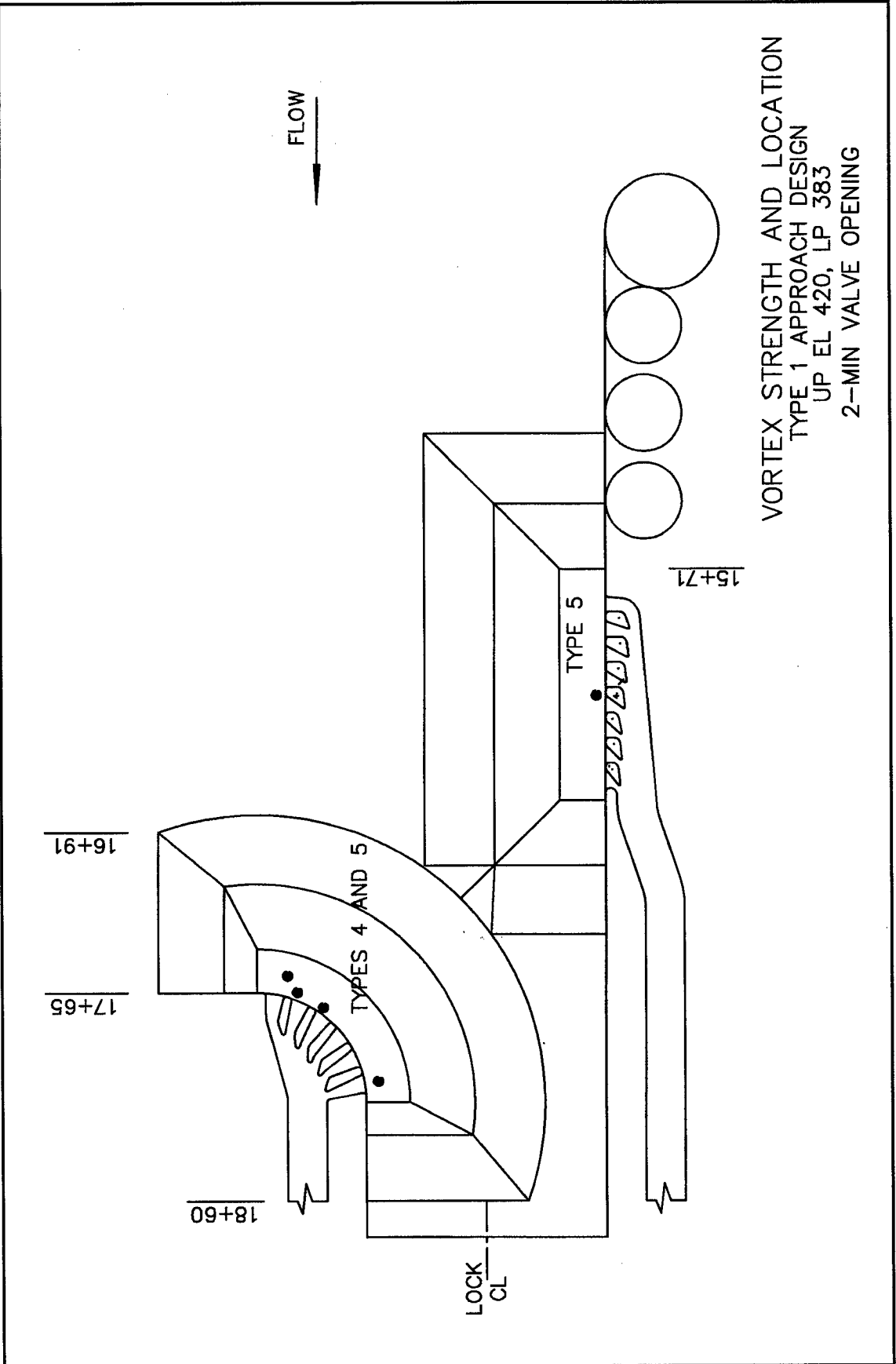

VORTEX STRENGTH AND LOCATION
 TYPE 1 APPROACH DESIGN
 UP EL 420, LP 383
 2-MIN VALVE OPENING

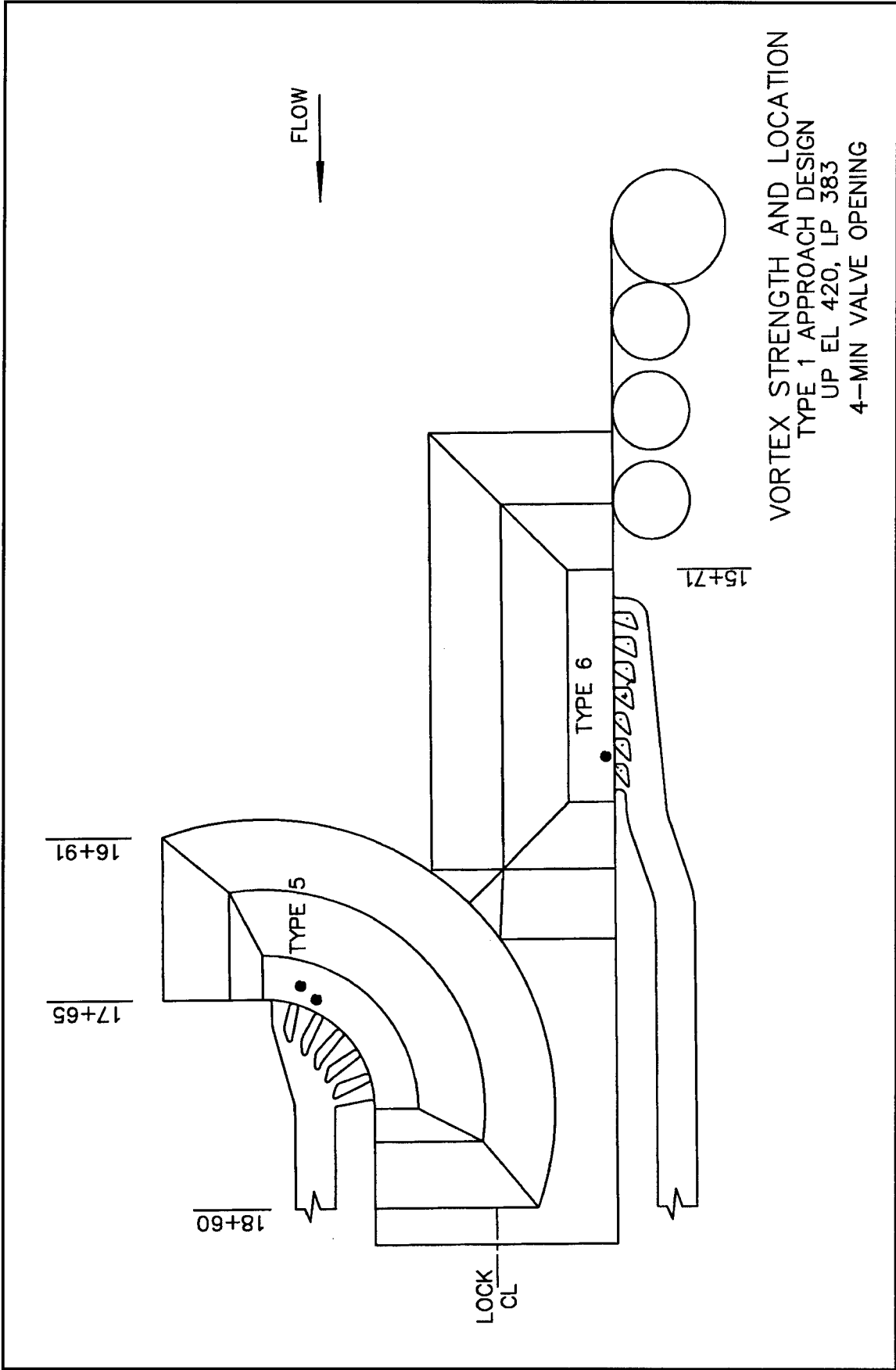
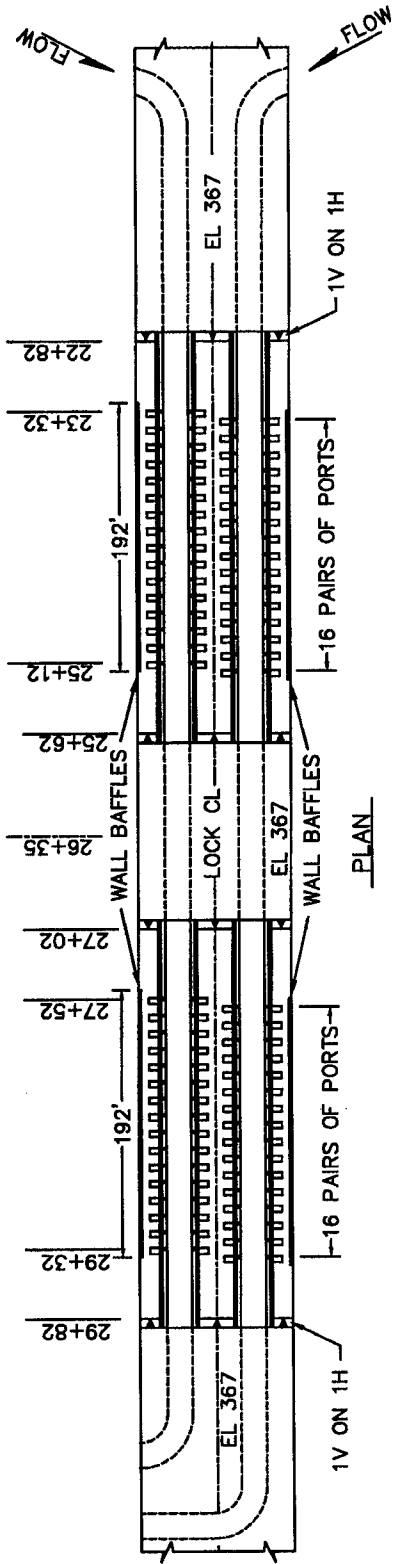

Plate 16



NOTE: TYPE 2 DESIGN CHAMBER HAS PORT EXTENSIONS ON ALL PORTS

TYPE 2 CHAMBER DESIGN

T2CHAM

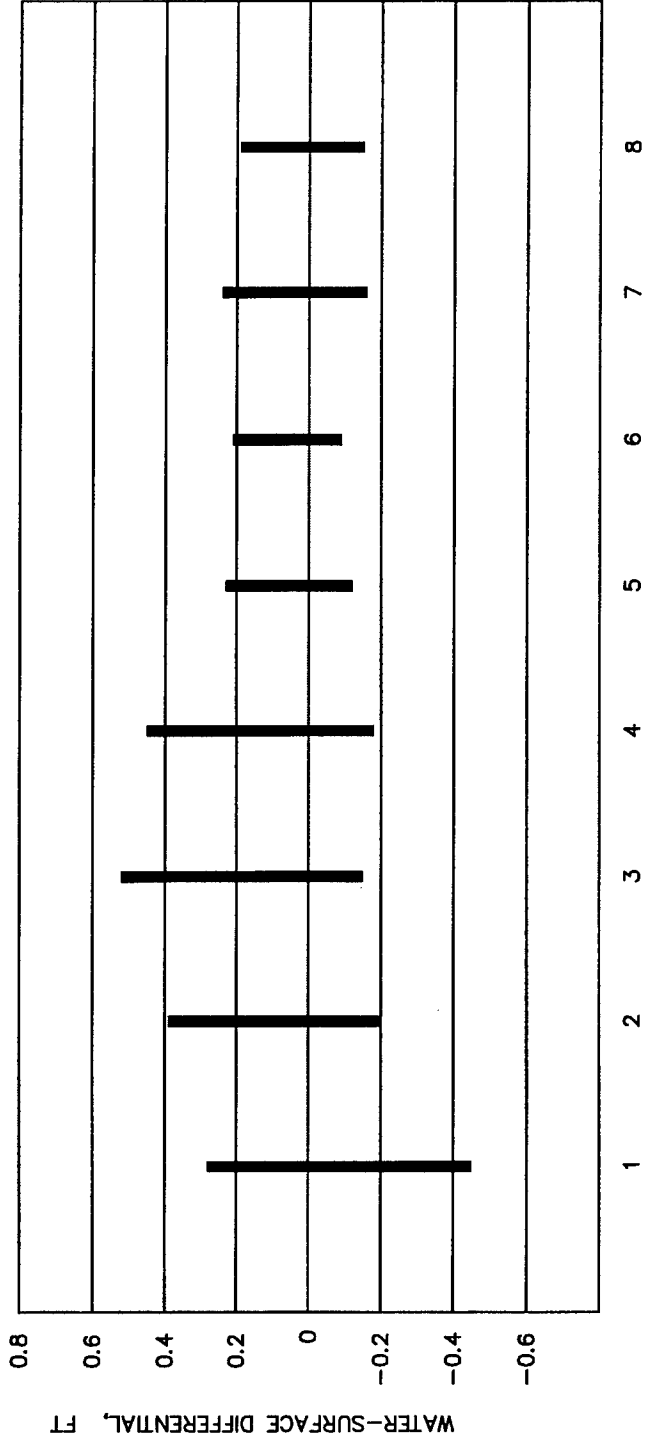

NOTE: + UPSTREAM W.S. HIGHER THAN DOWNSTREAM W.S.
 - DOWNSTREAM W.S. HIGHER THAN UPSTREAM W.S.

WATER-SURFACE DIFFERENTIALS
 TYPE 1-8 DESIGNS
 4-MIN VALVE

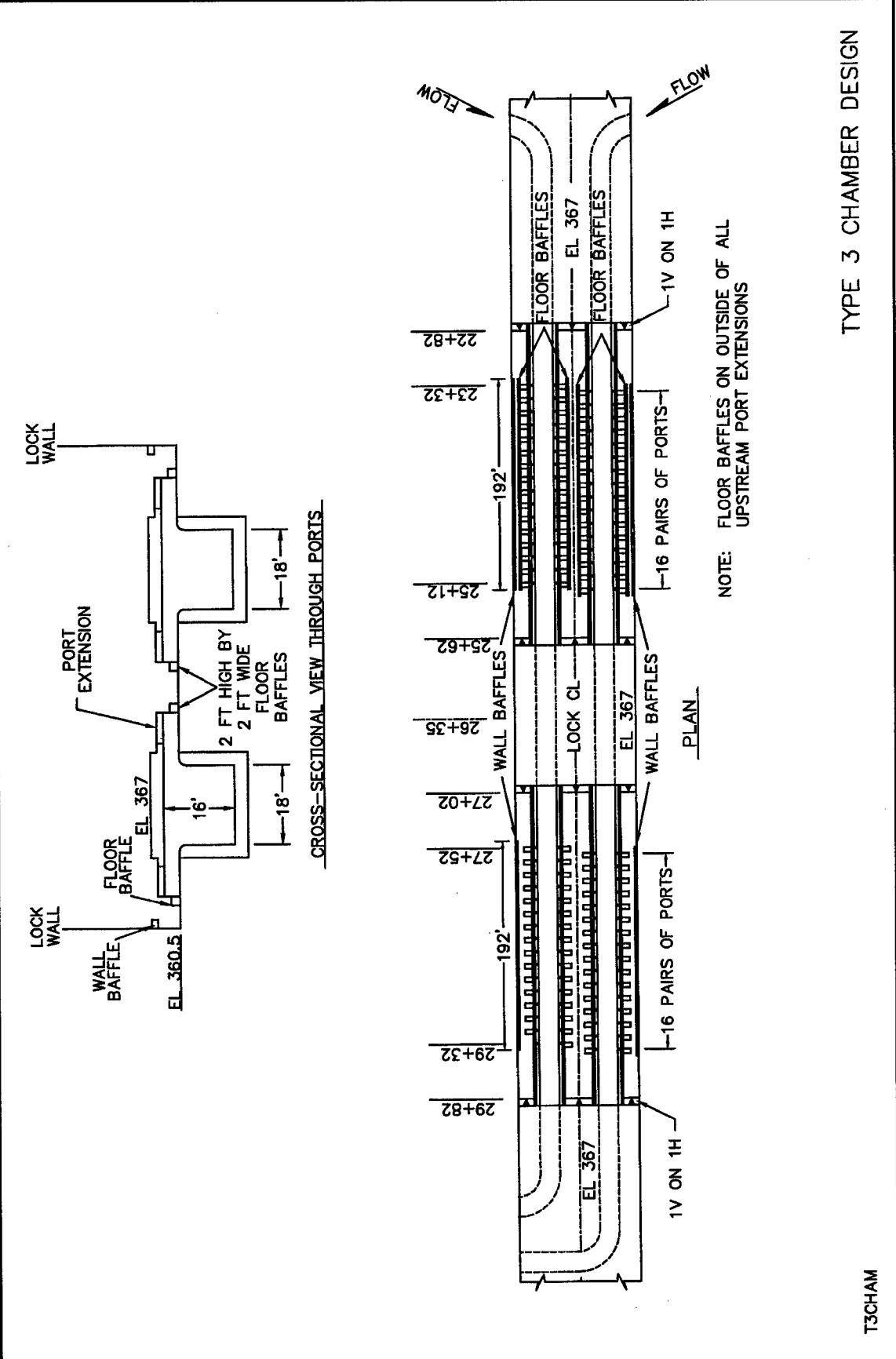

TYPE 3 CHAMBER DESIGN

T3CHAM

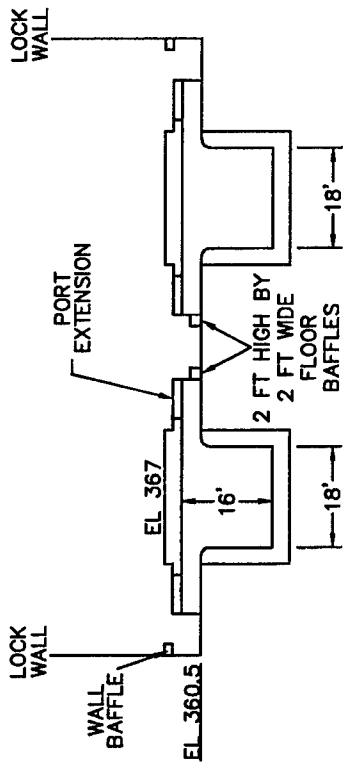

CROSS-SECTIONAL VIEW THROUGH UPSTREAM PORTS

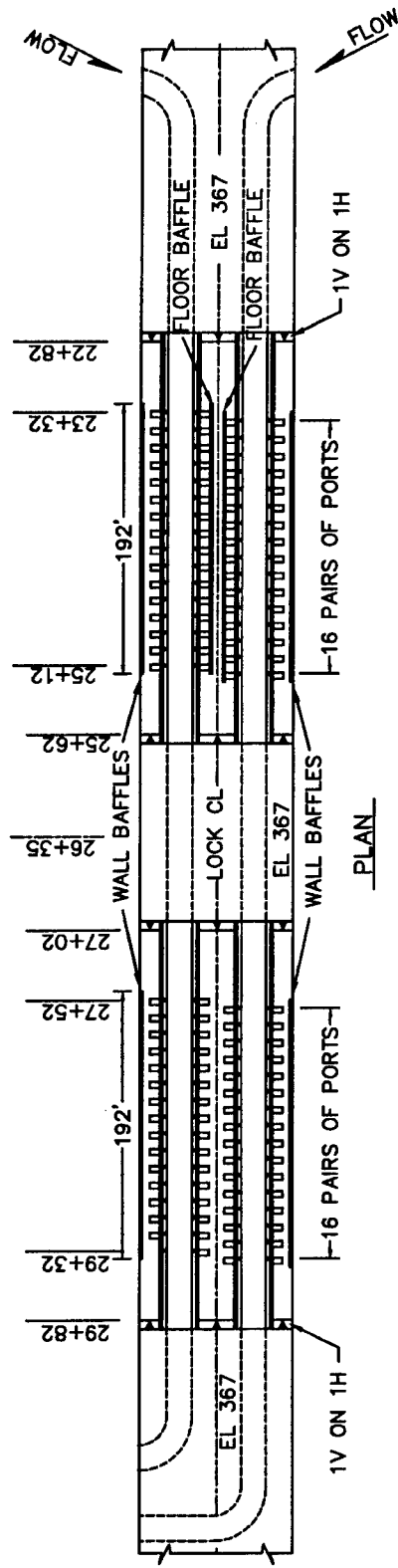

NOTE: FLOOR BAFFLES ON OUTSIDE OF CENTER UPSTREAM PORT EXTENSIONS ONLY

TYPE 4 CHAMBER DESIGN

T4CHAM

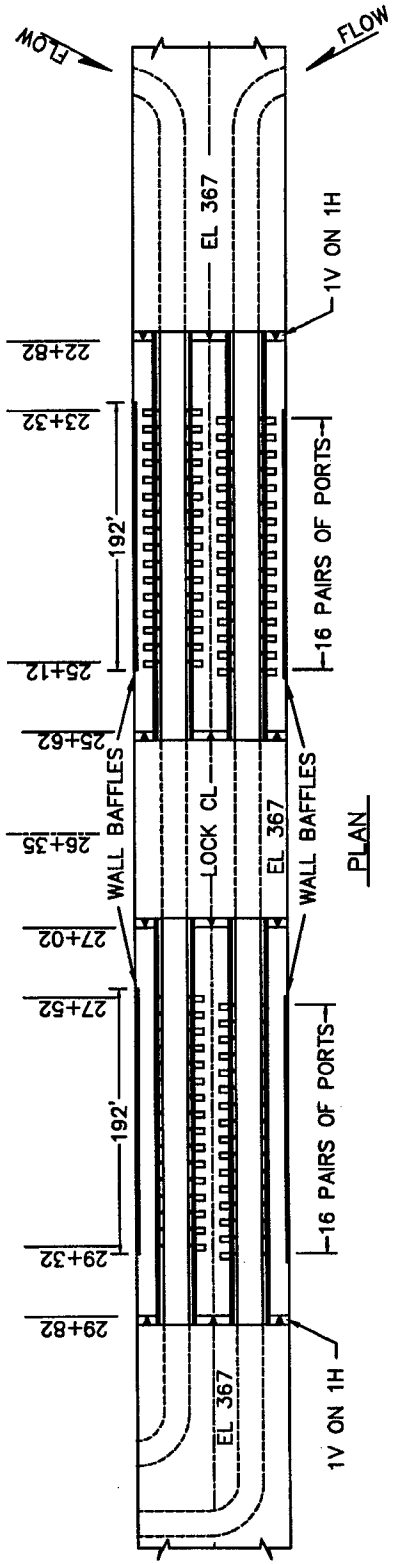

NOTE: TYPE 5 DESIGN CHAMBER HAS PORT EXTENSIONS ON ALL UPSTREAM PORTS AND CENTER DOWNSTREAM PORTS

TYPE 5 CHAMBER DESIGN

T5CHAM

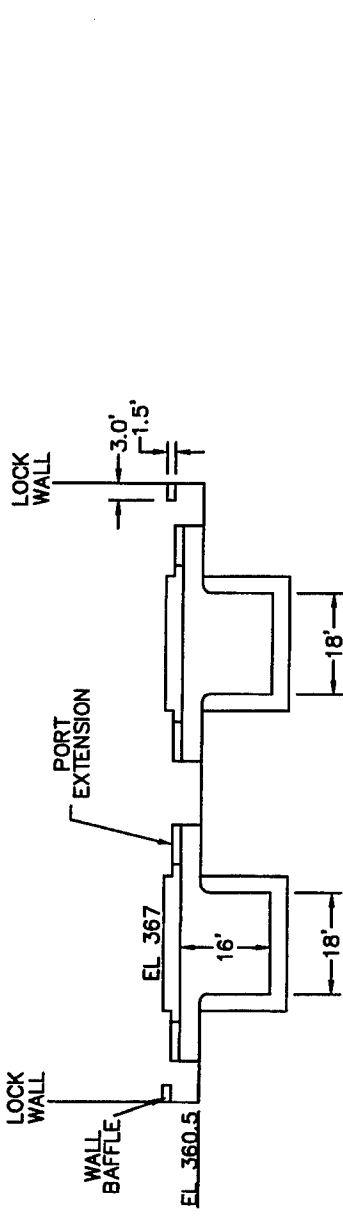

CROSS-SECTIONAL VIEW THROUGH UPSTREAM PORTS

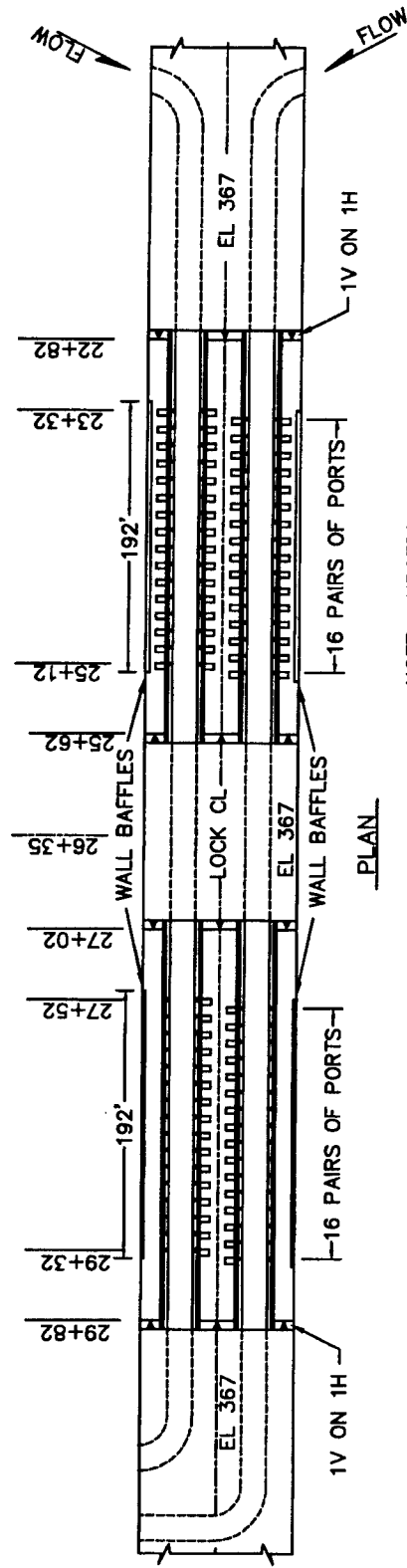

NOTE: UPSTREAM WALL BAFFLES CHANGED FROM 2 FT WIDE TO 3 FT WIDE

TYPE 6 CHAMBER DESIGN

T6CHAM

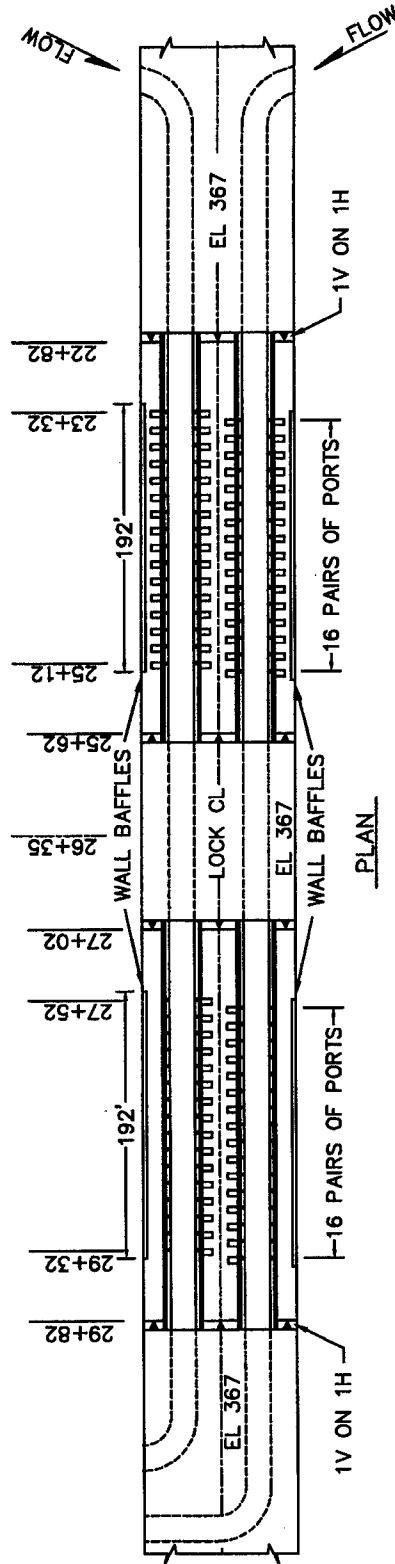
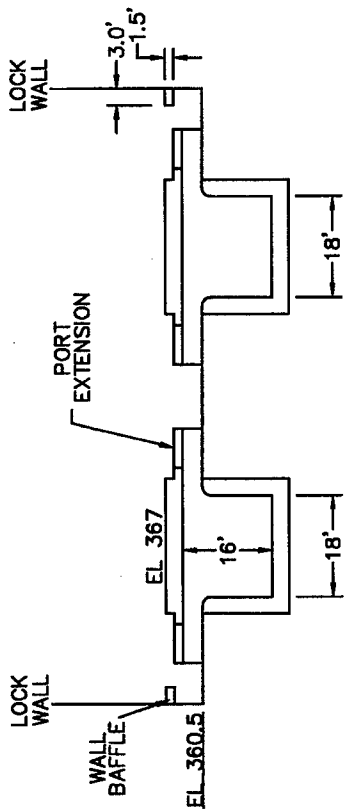

NOTE: WALL BAFFLES 3 FT WIDE BOTH UPSTREAM AND DOWNSTREAM

TYPE 7 CHAMBER DESIGN

T7CHAM

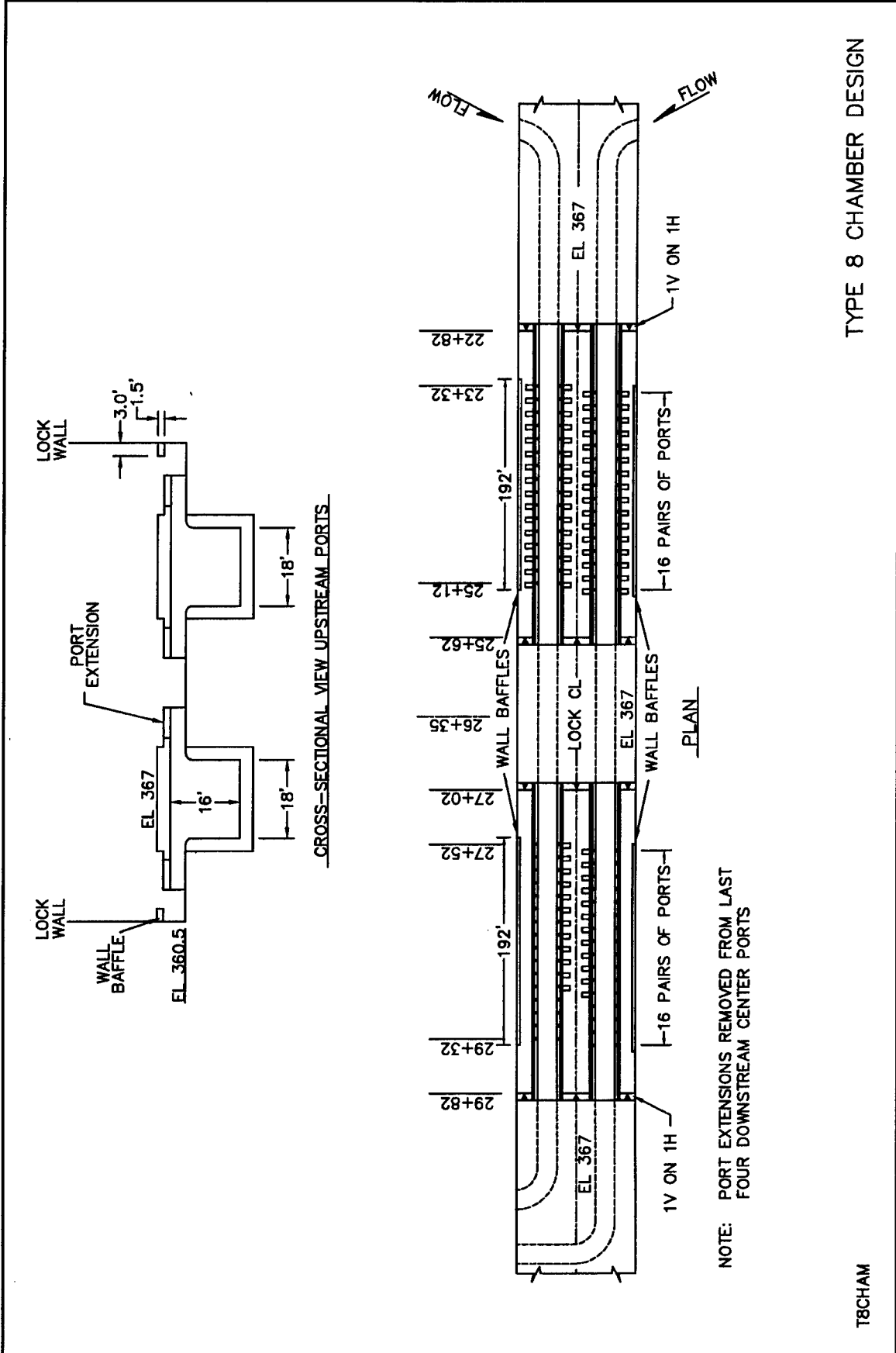

TYPE 8 CHAMBER DESIGN

T8CHAM

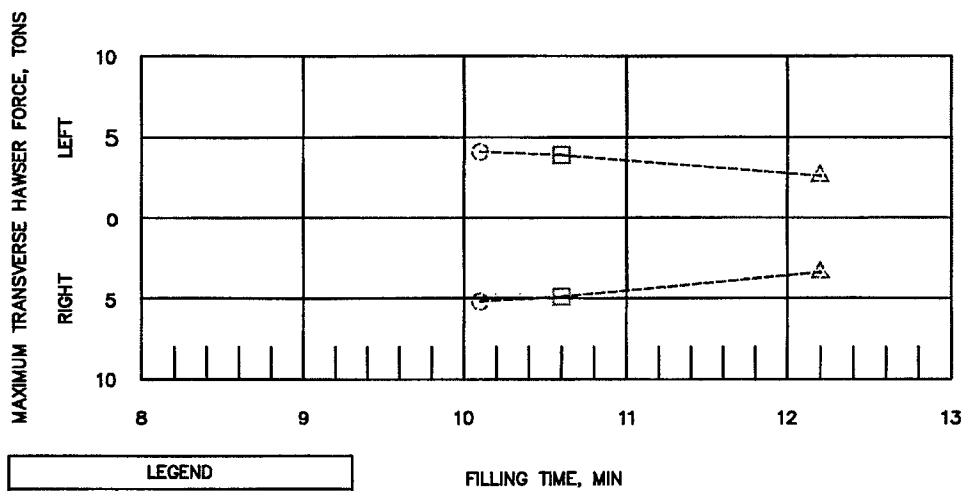
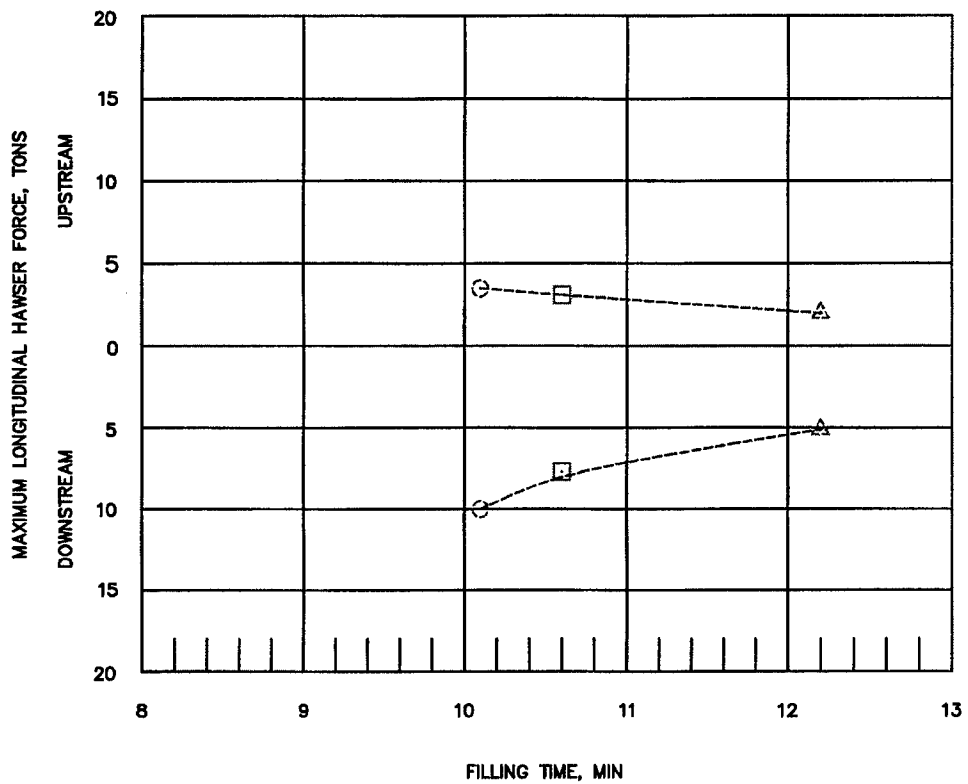

LEGEND	
SYMBOL	VALVE SCHEDULE, MIN
○	4
□	5
△	8
LINE TYPE	DESIGN TYPE
-----	8

HAWSER FORCES
DURING FILLING
TYPE 8 CHAMBER DESIGN

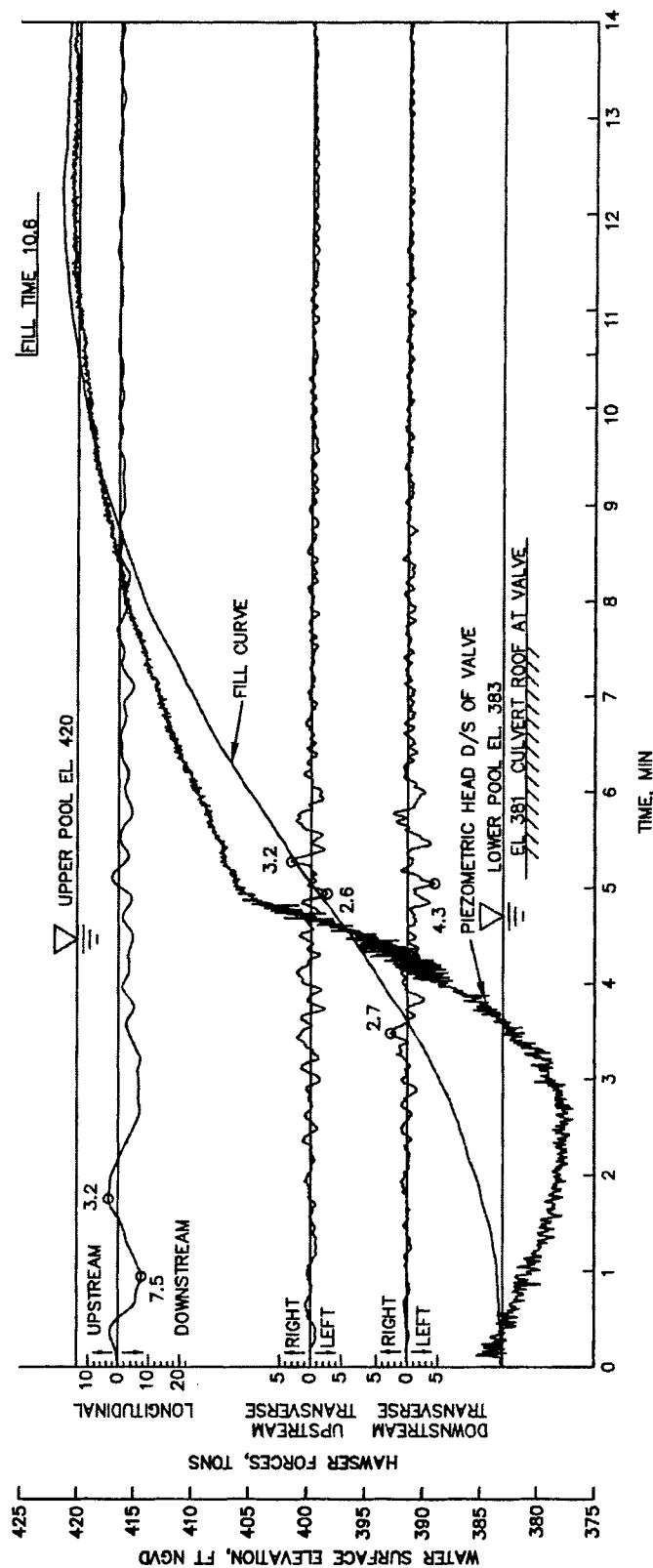

FILLING CHARACTERISTICS
 TYPE 8 CHAMBER DESIGN
 5 - MIN NORMAL FILL TEST 1

MACSF.011

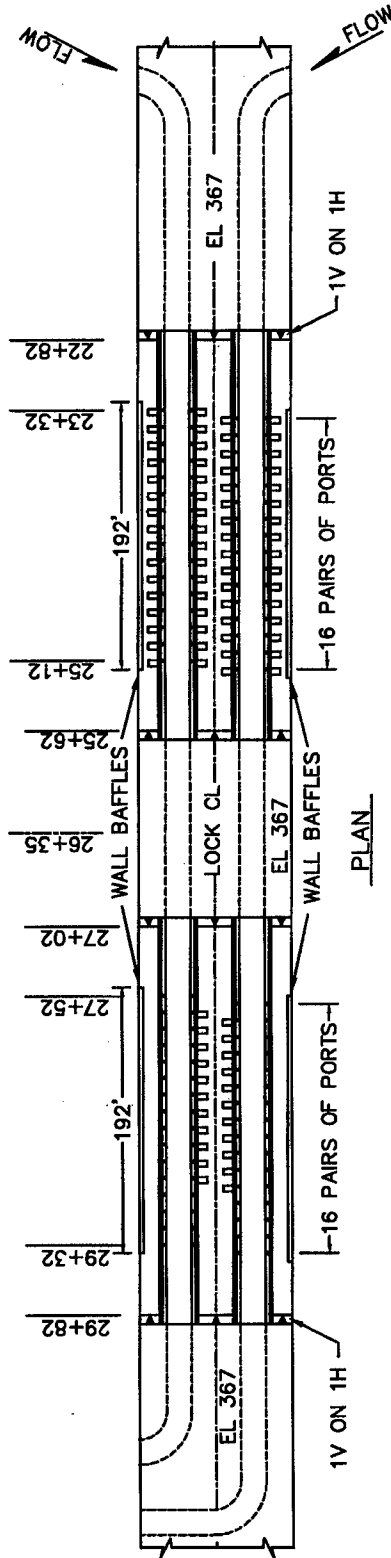
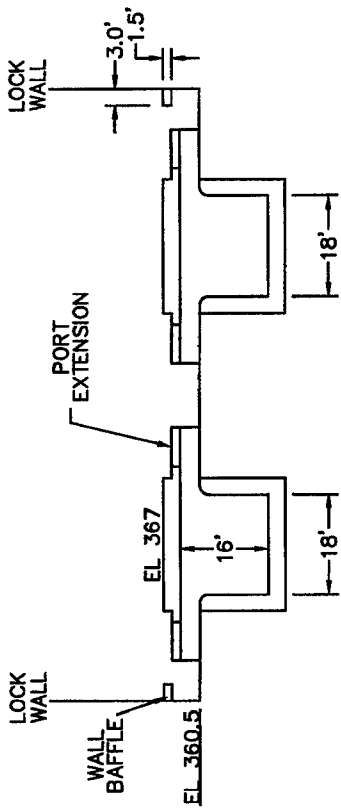

NOTE: PORT EXTENSIONS REMOVED FROM FIRST AND LAST FOUR DOWNSTREAM CENTER PORTS

TYPE 9 CHAMBER DESIGN

T9CHAM

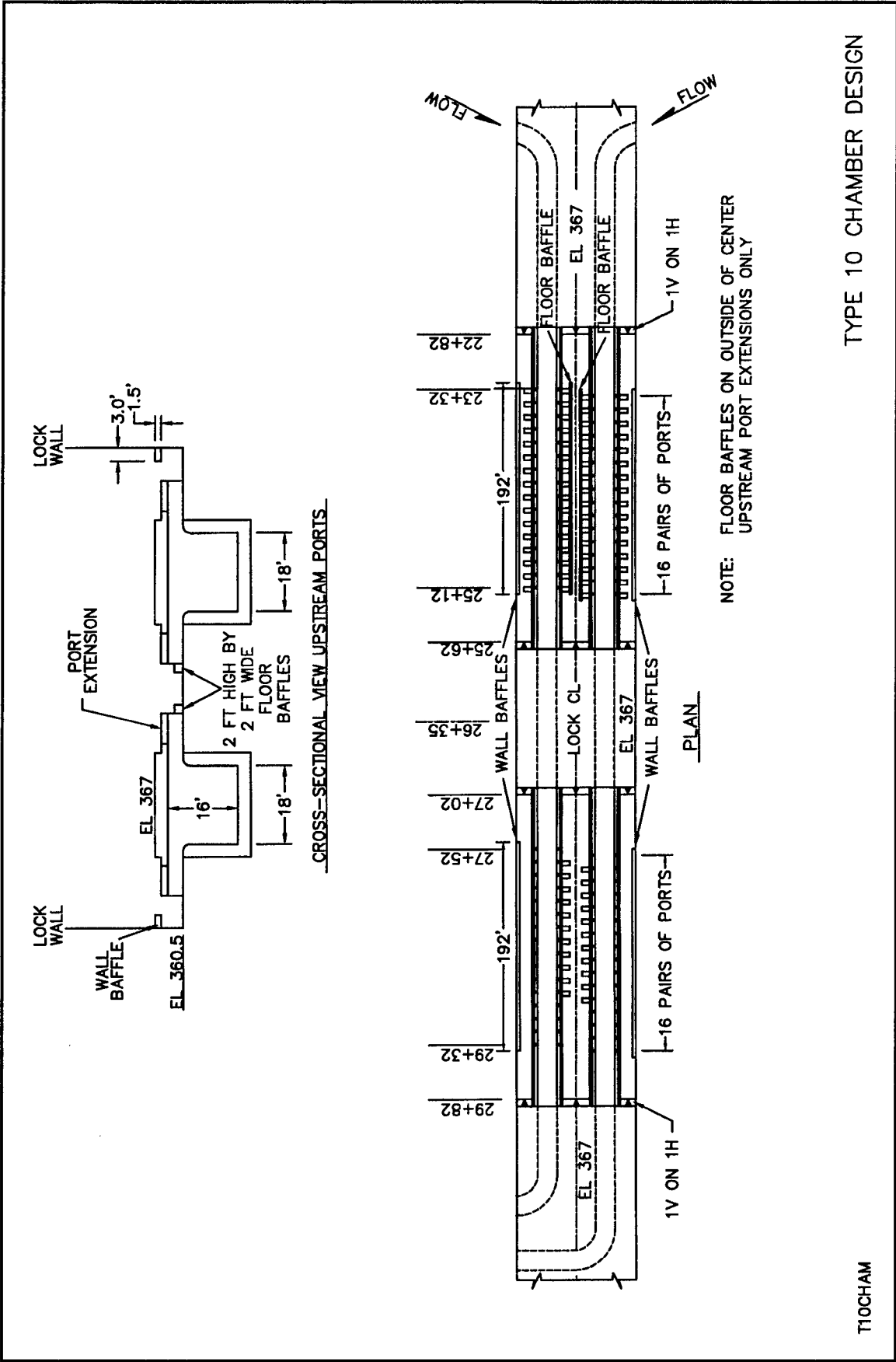

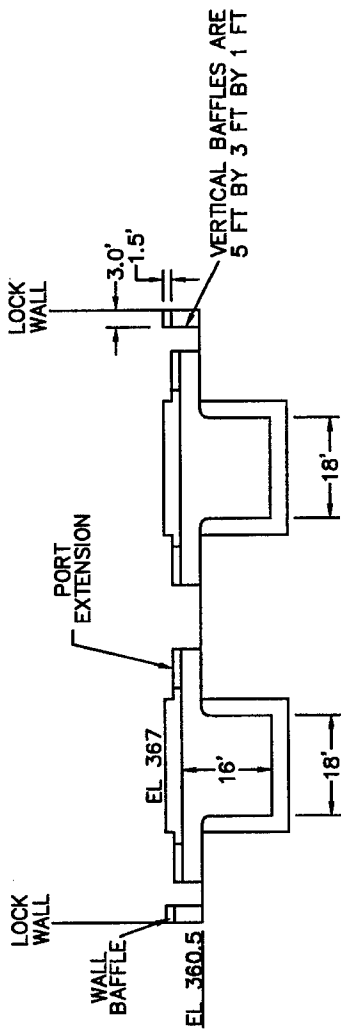

CROSS-SECTIONAL VIEW UPSTREAM PORTS

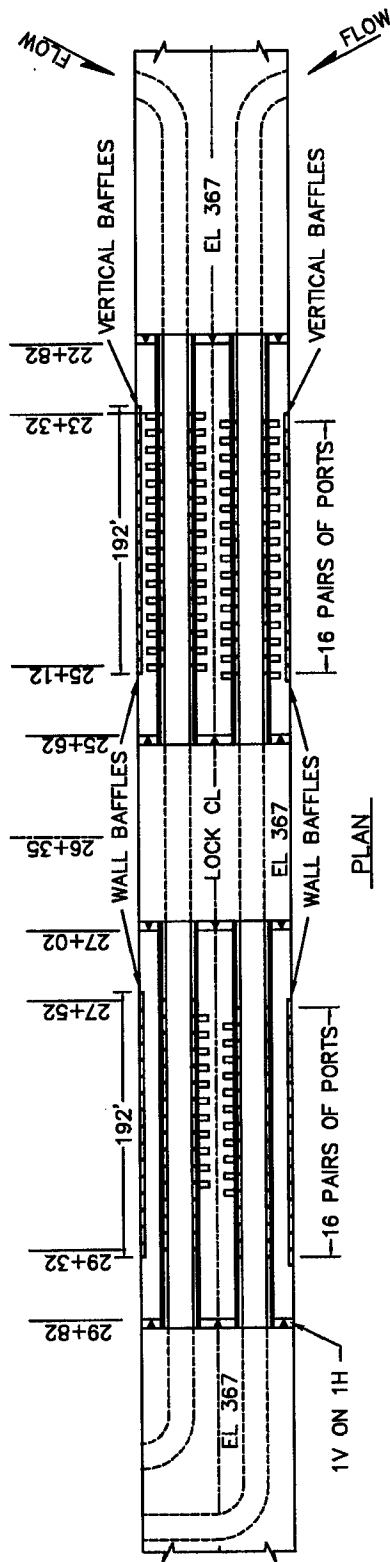

NOTE: VERTICAL BAFFLES EXTEND FROM BOTTOM OF WALL BAFFLE TO FLOOR OF LOCK AND ARE LOCATED AT END OF WALL BAFFLE AND MIDWAY BETWEEN PORTS

TYPE 11 CHAMBER DESIGN

T11CHAM

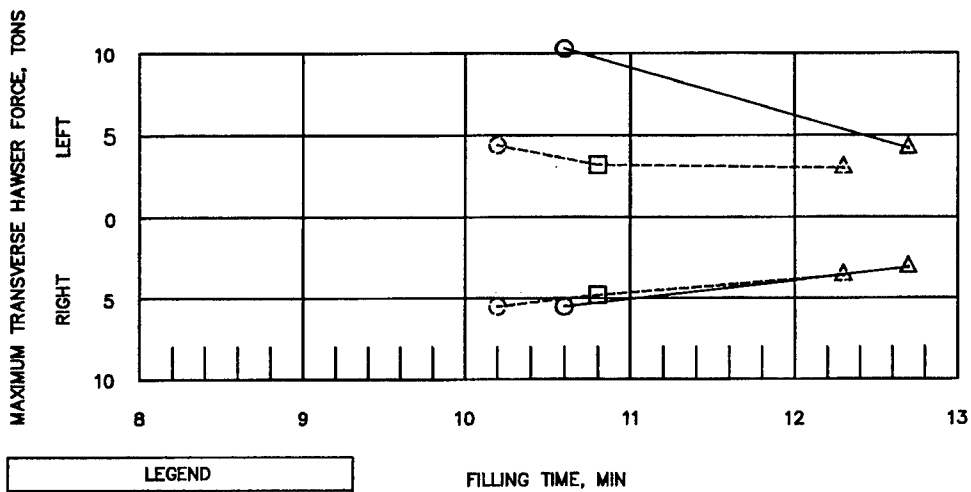
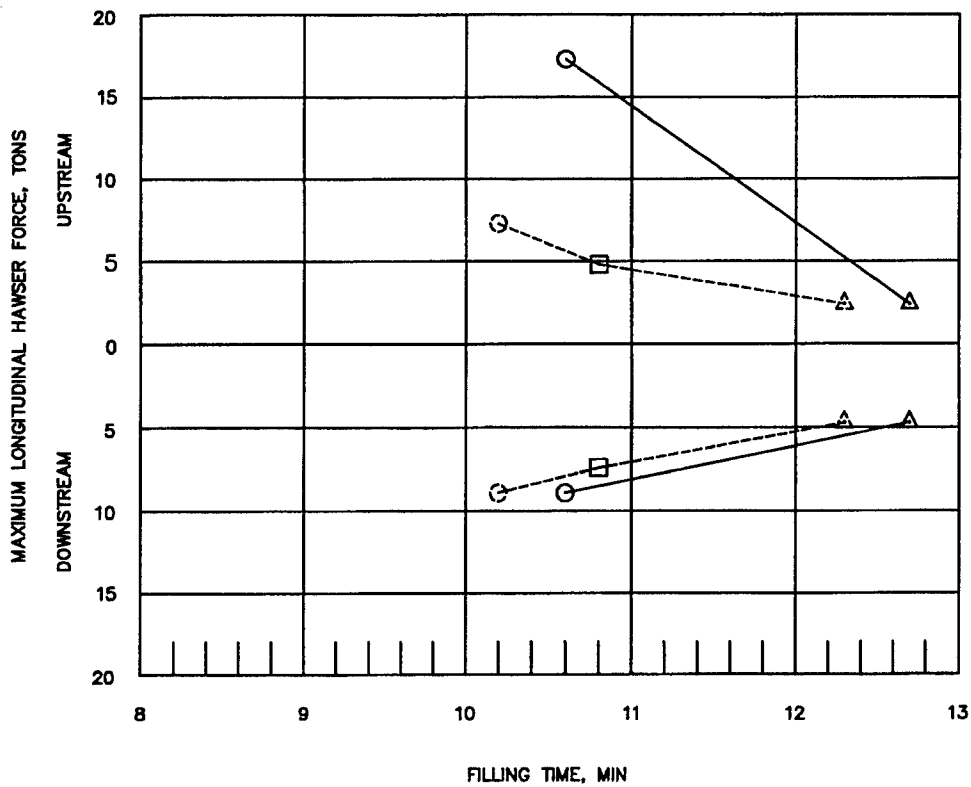

LEGEND	
SYMBOL	VALVE SCHEDULE, MIN
○	4
□	5
△	8
LINE TYPE	DESIGN TYPE
————	1
-----	11

HAWSER FORCES
DURING FILLING
TYPE 1 AND 11 DESIGNS

Hawser force is in tons. To convert to newtons multiply by 8,896.443.

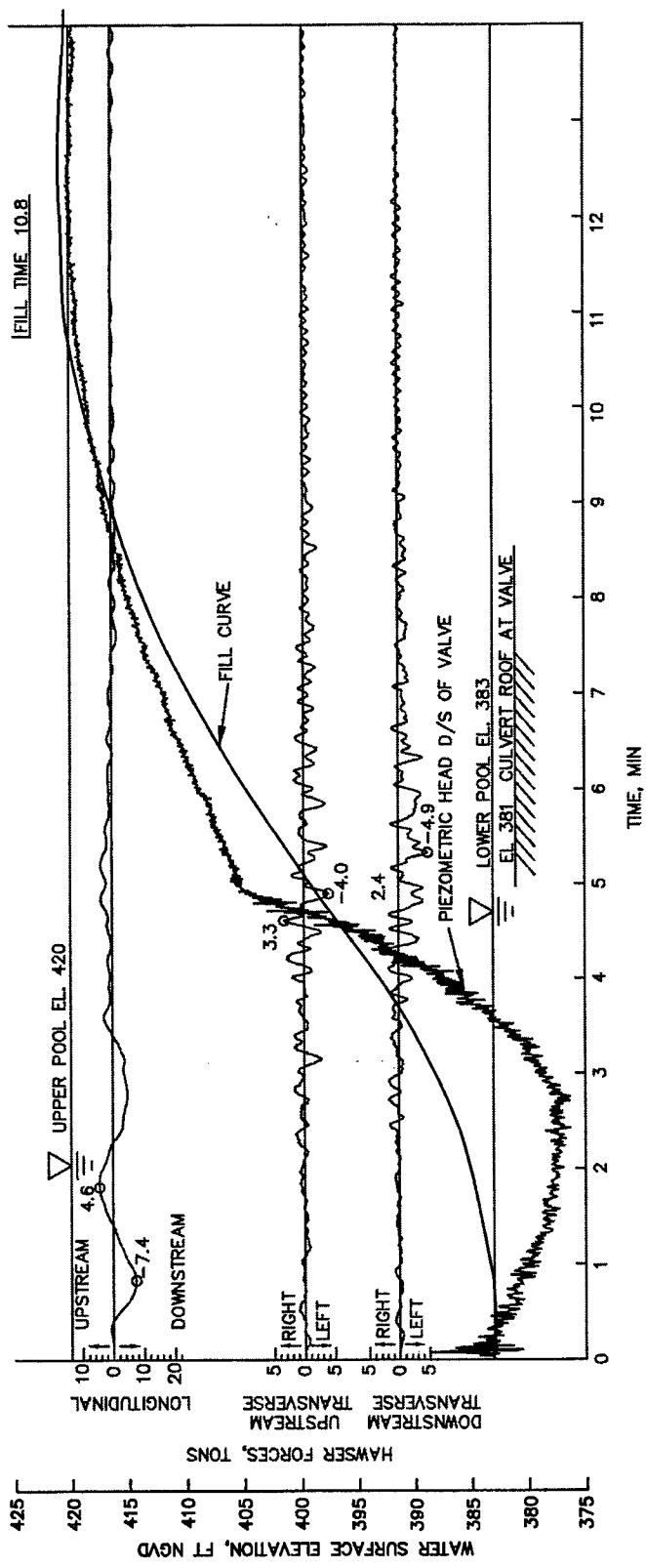

McALPINE FILLING AND EMPTYING SYSTEM
 CHAMBER TYPE 11
 5 - MIN NORMAL FILL TEST 2

MAC5F.024

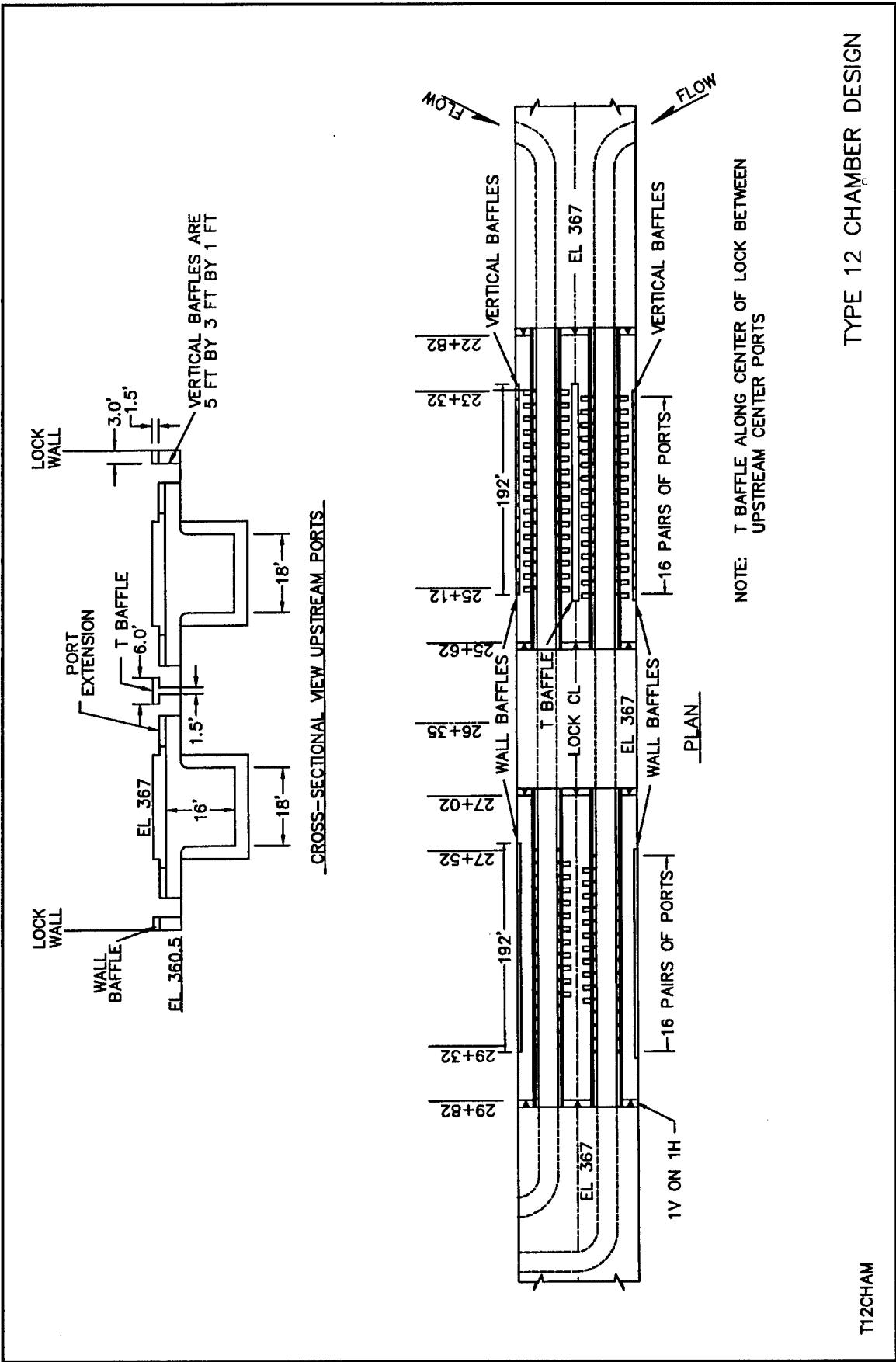

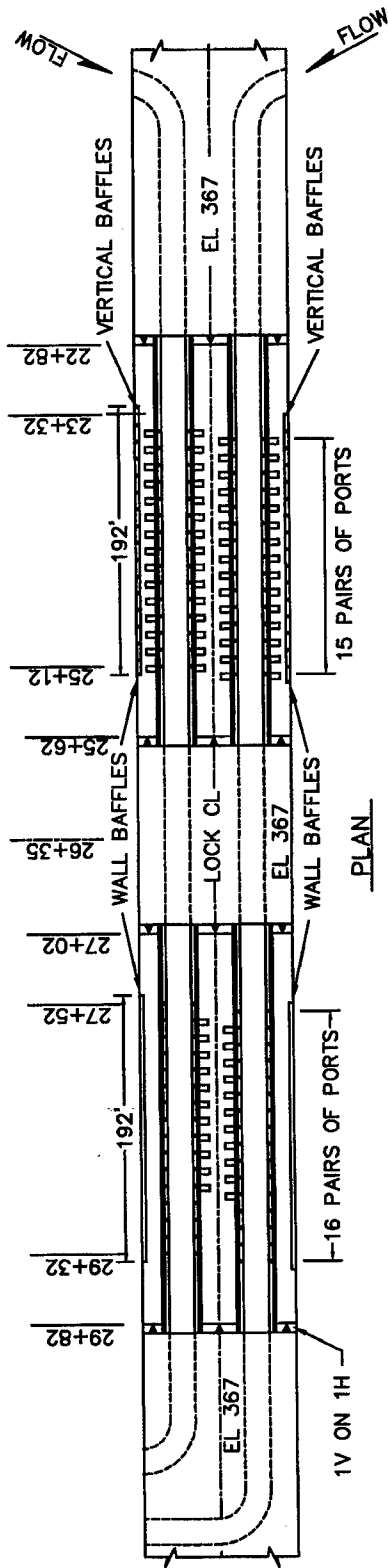
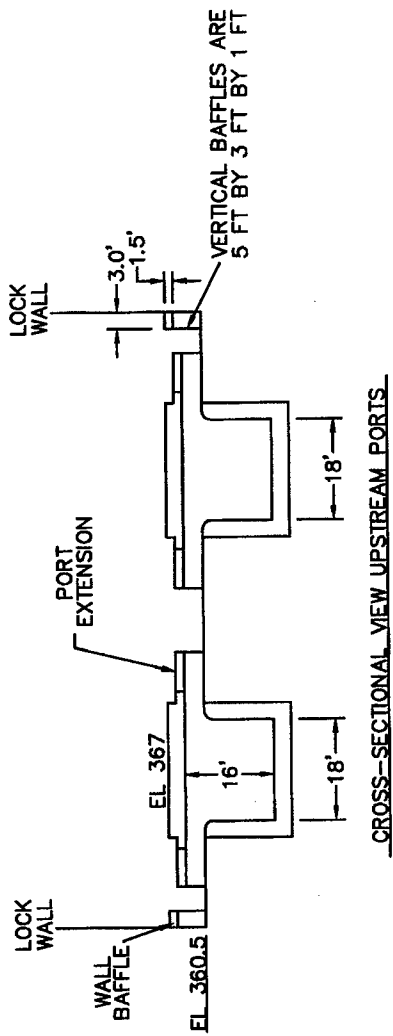

NOTE: FIRST FOUR UPSTREAM PORTS REMOVED

TYPE 13 CHAMBER DESIGN

T13CHAM

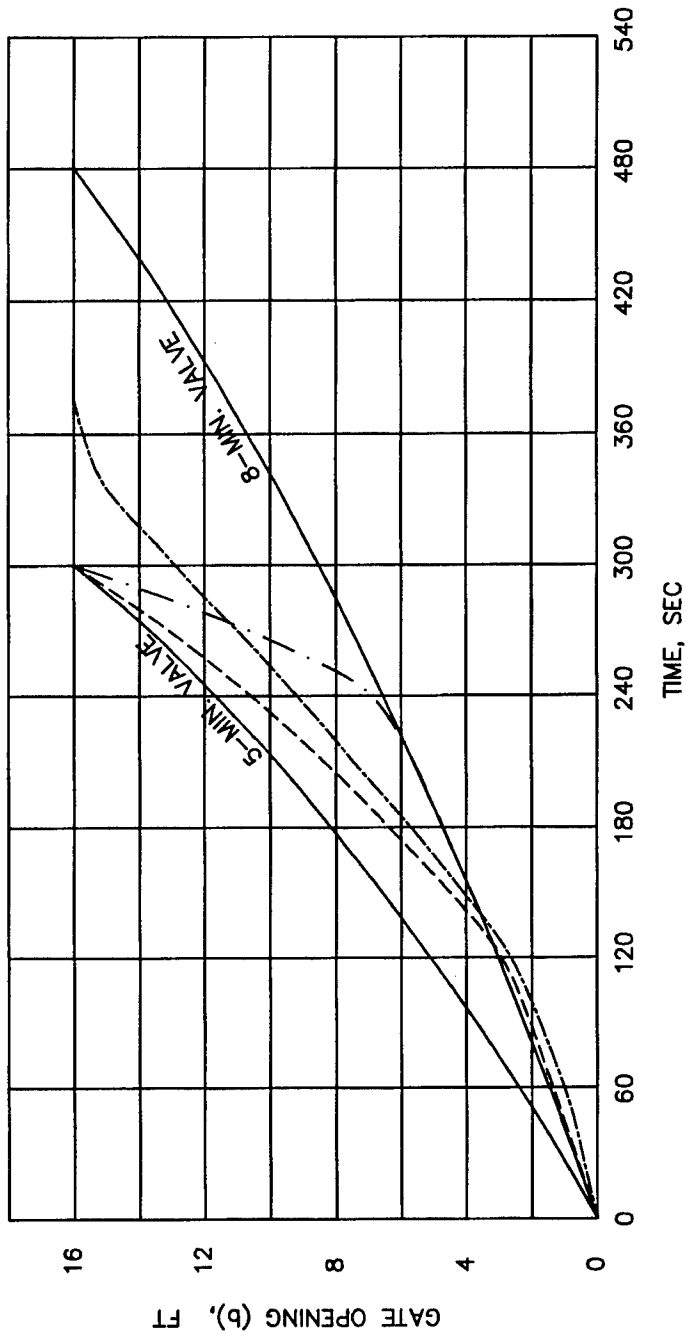

b = VERTICAL DIST. FROM LIP TO FLOOR

- 2-MIN. OF 8-MIN. VALVE SCHEDULE AND 3 MIN. TO OPEN
- 4-MIN. OF 8-MIN. VALVE SCHEDULE AND 1 MIN. TO OPEN
- 2-MIN. OF 8-MIN. VALVE SCHEDULE AND 4.25 MIN. TO OPEN

VALVE OPENING CURVES

VARVAL

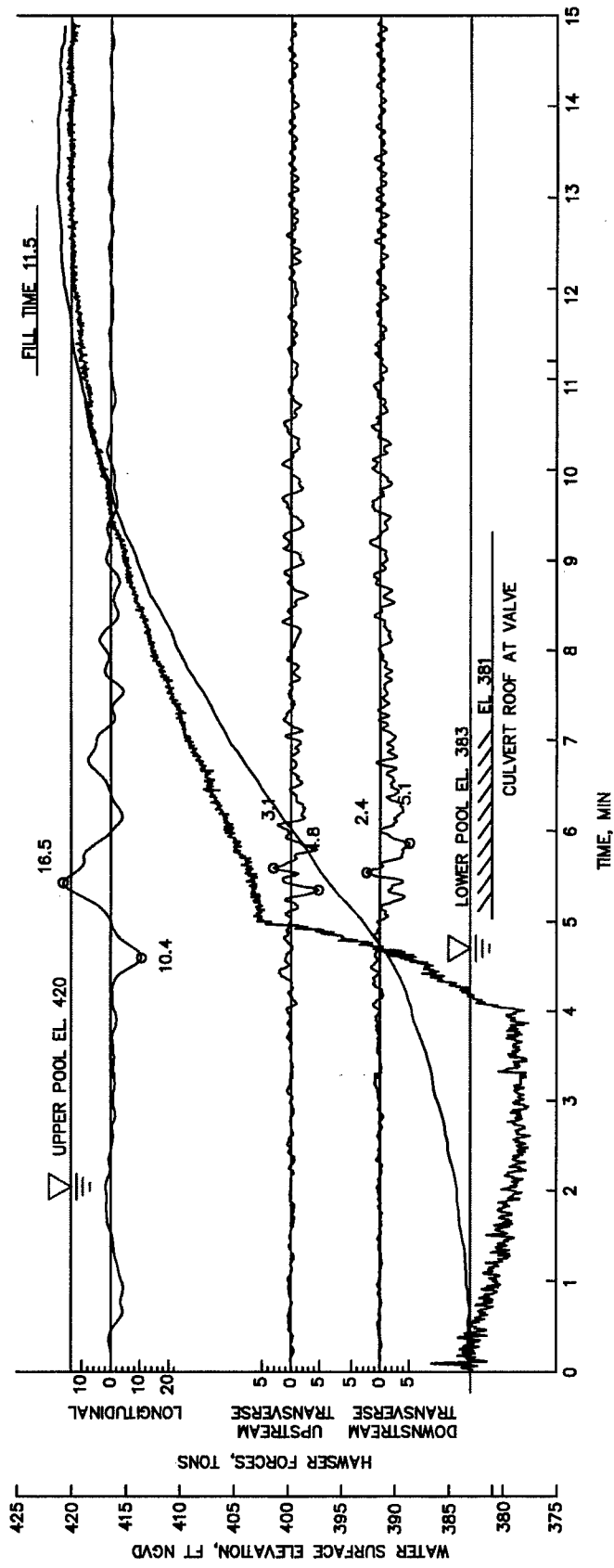

NOTE: VALVE OPERATION CONSISTS OF 4 MIN OF 8-MIN VALVE SCHEDULE AND 1 MIN TO FULLY OPEN

FILLING CHARACTERISTICS
 TYPE 11 CHAMBER DESIGN
 FIRST VARIABLE VALVE TEST 3

MAC45SF.003

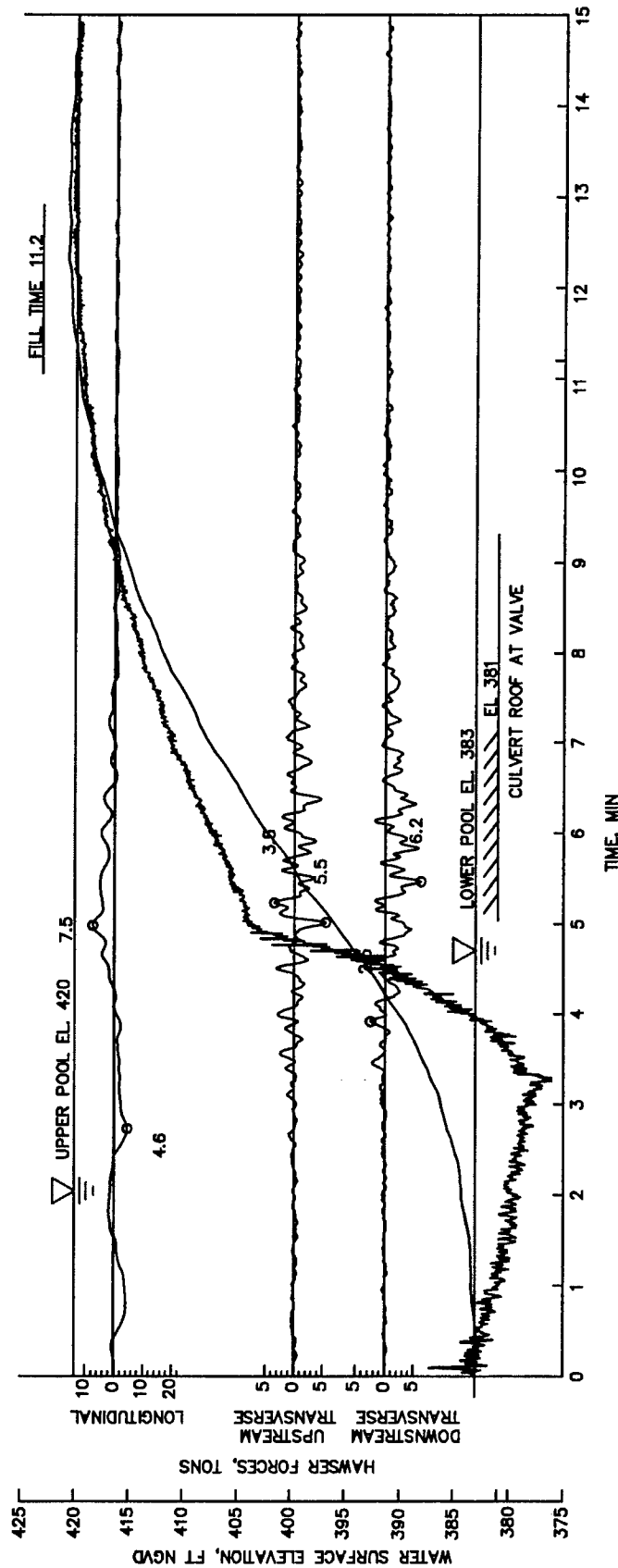

NOTE: VALVE OPERATION CONSISTS OF 2 MIN OF 8-MIN VALVE SCHEDULE AND 3 MIN TO FULLY OPEN

FILLING CHARACTERISTICS
 TYPE 11 CHAMBER DESIGN
 SECOND VARIABLE VALVE TEST 2

MAC25SF.002

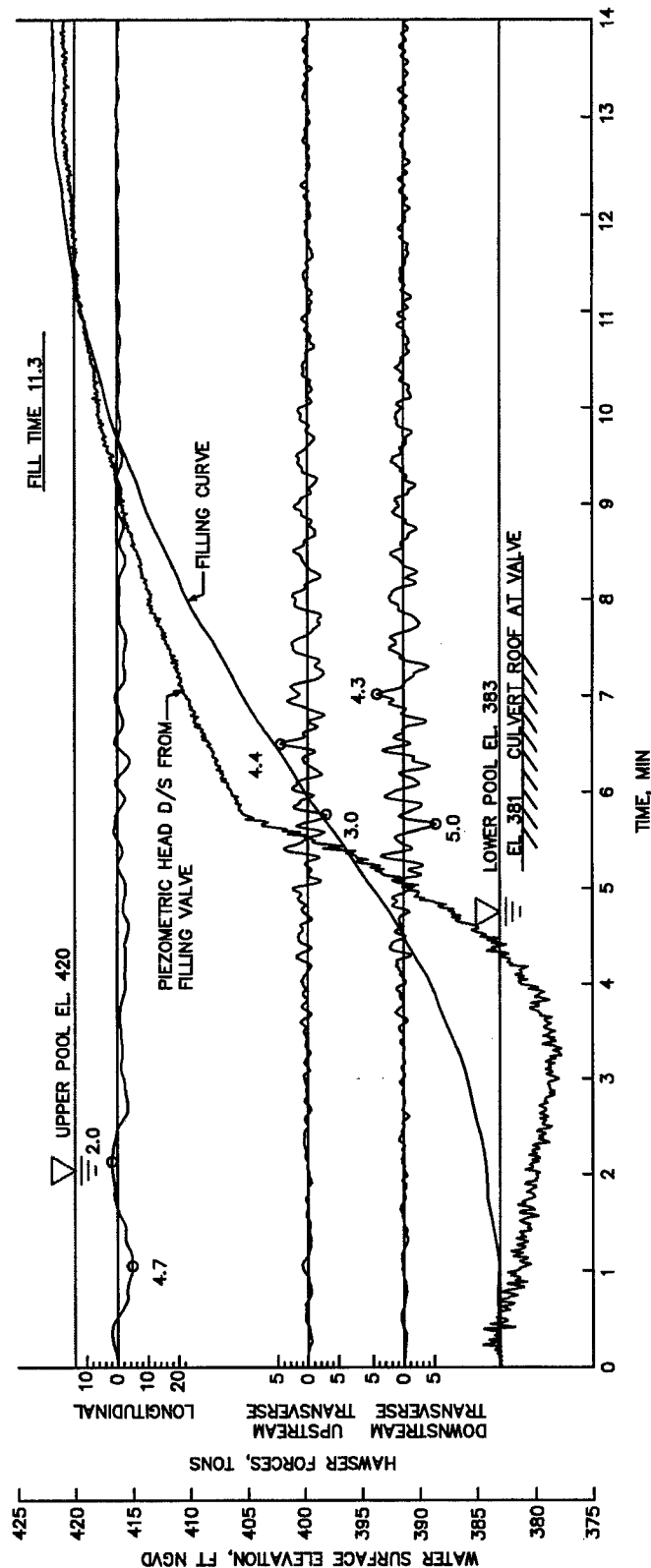

FILLING CHARACTERISTICS
 TYPE 11 CHAMBER DESIGN
 LRL VALVE OPERATION TEST NO. 3

MAC8F.004

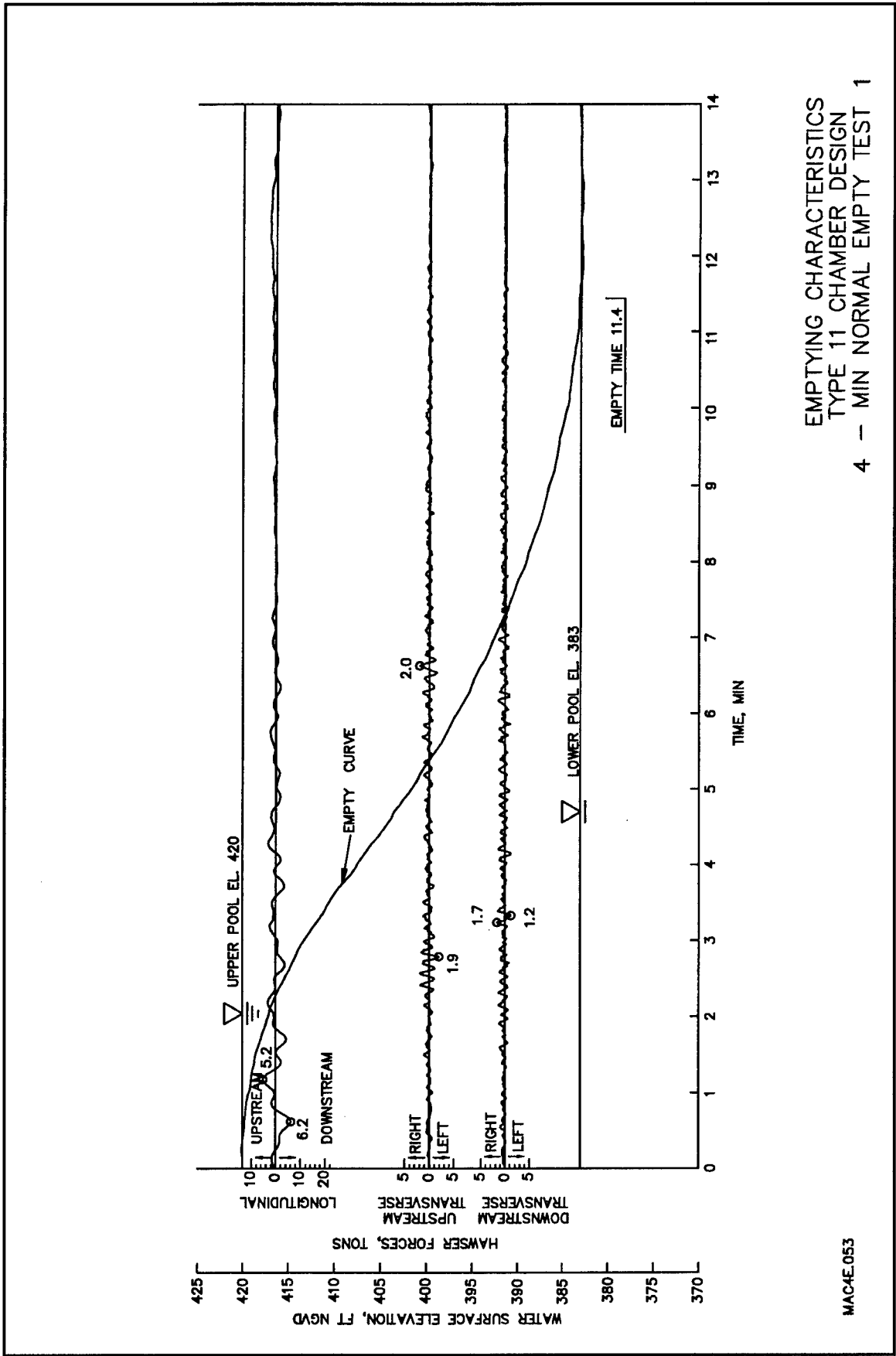

EMPTYING CHARACTERISTICS
 TYPE 11 CHAMBER DESIGN
 4 - MIN NORMAL EMPTY TEST 1

MAC4E.053

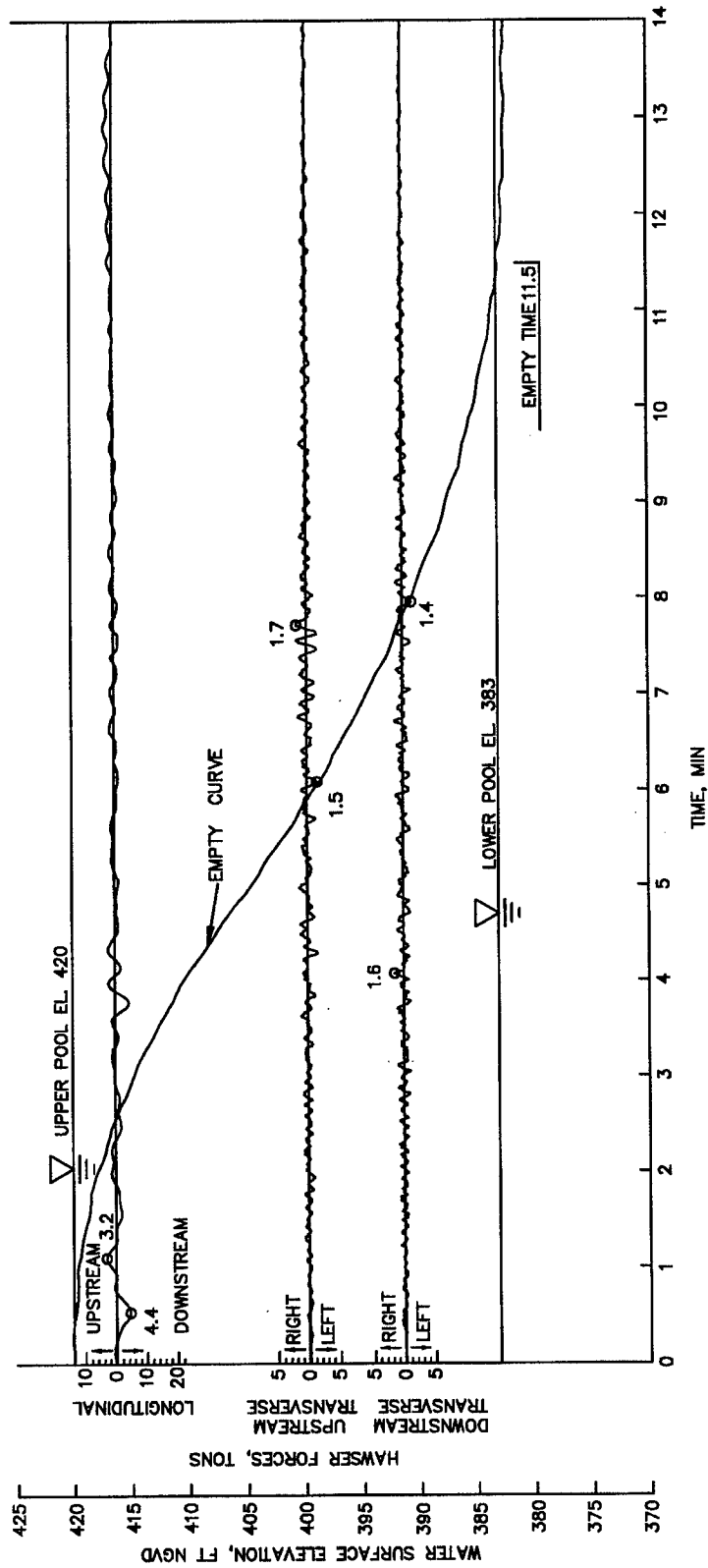

EMPTYING CHARACTERISTICS
 TYPE 11 CHAMBER DESIGN
 5 - MIN NORMAL EMPTY TEST 2

MAC5E.024

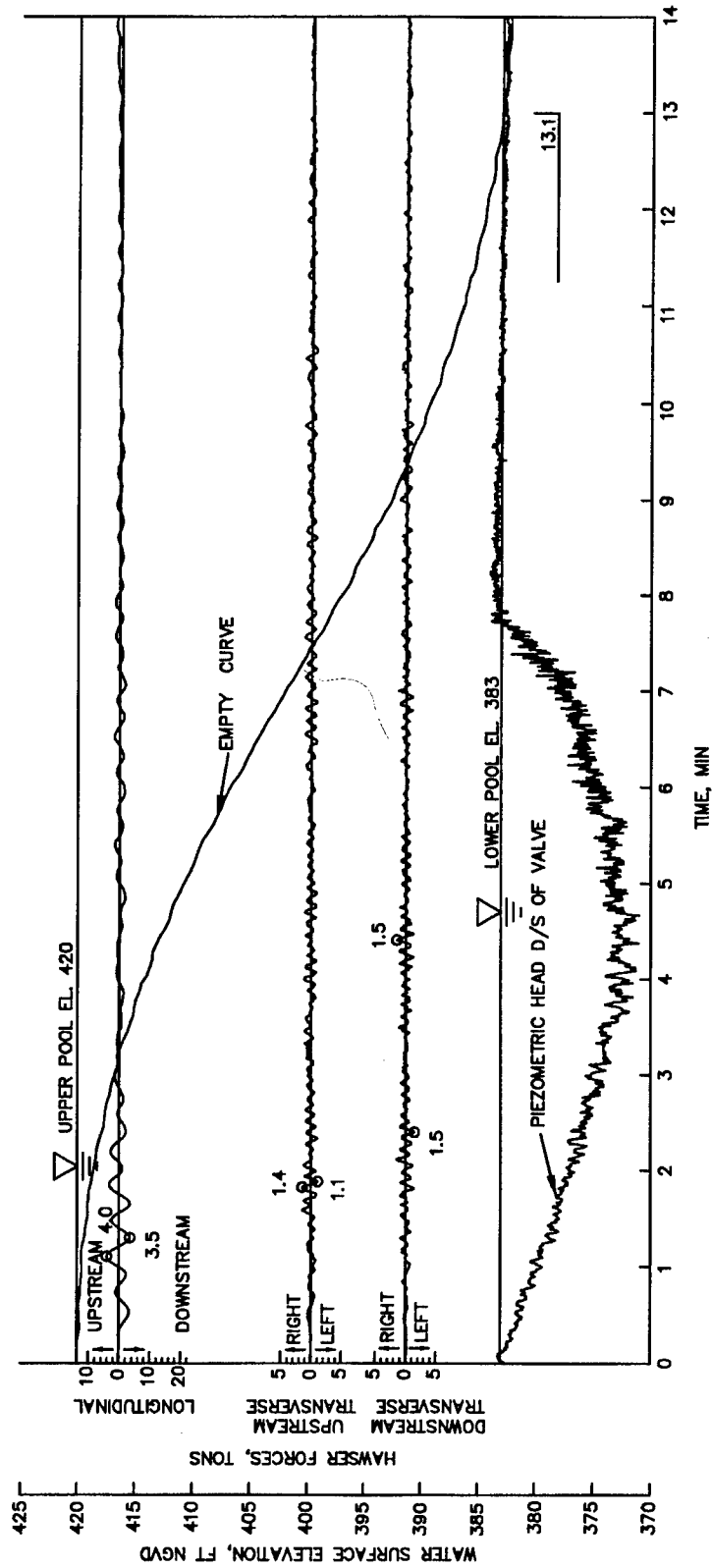

EMPTYING CHARACTERISTICS
 TYPE 11 CHAMBER DESIGN
 8 - MIN NORMAL EMPTY TEST 2

MACBE.024

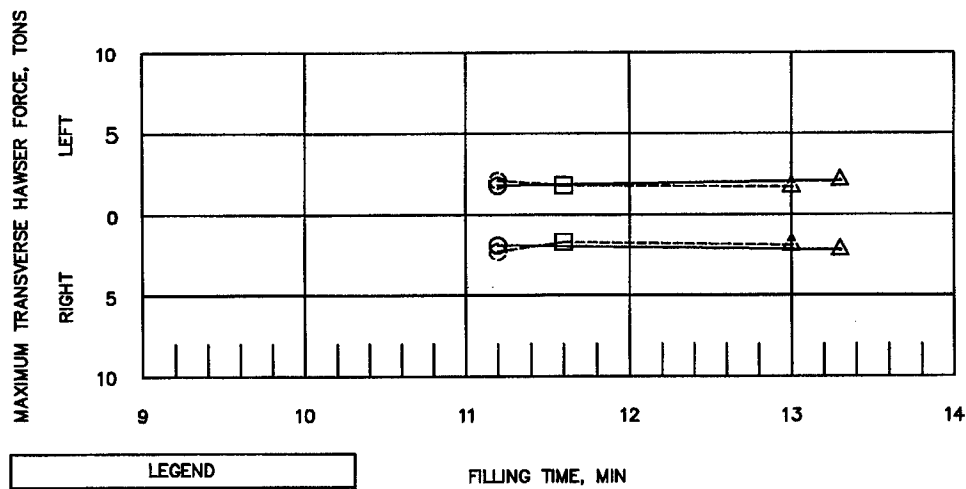
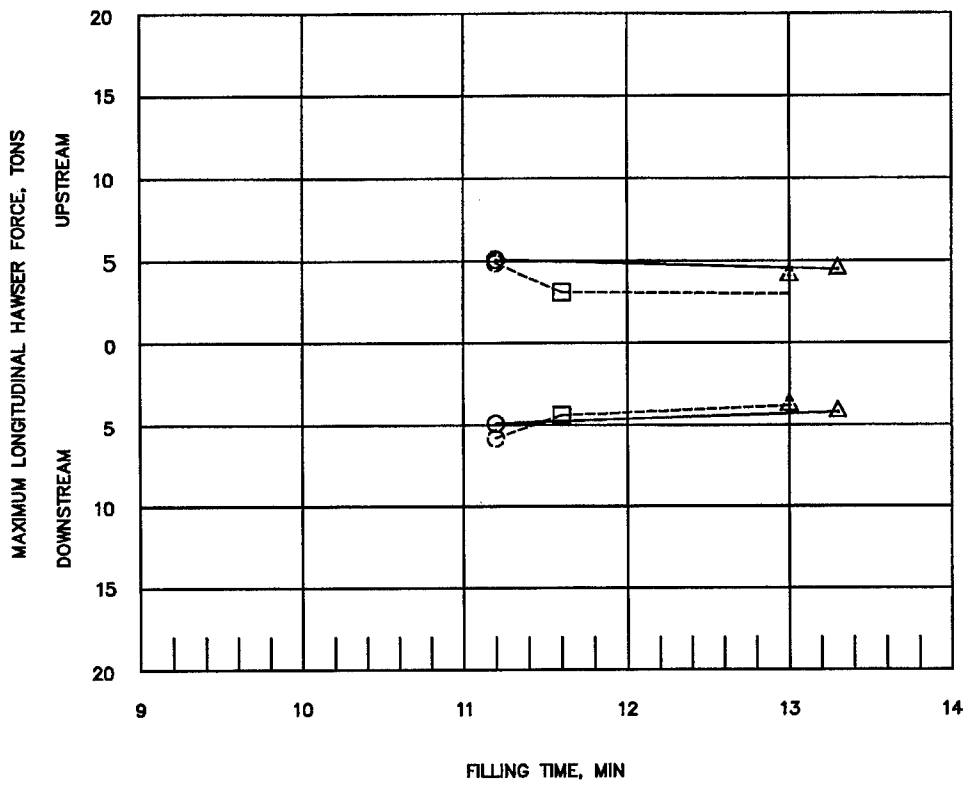

LEGEND	
SYMBOL	VALVE SCHEDULE, MIN
○	4
□	5
△	8
LINE TYPE	DESIGN TYPE
—	TYPE 1
- - -	TYPE 11

HAWSER FORCES
DURING EMPTYING
TYPE 1 AND 11 DESIGNS

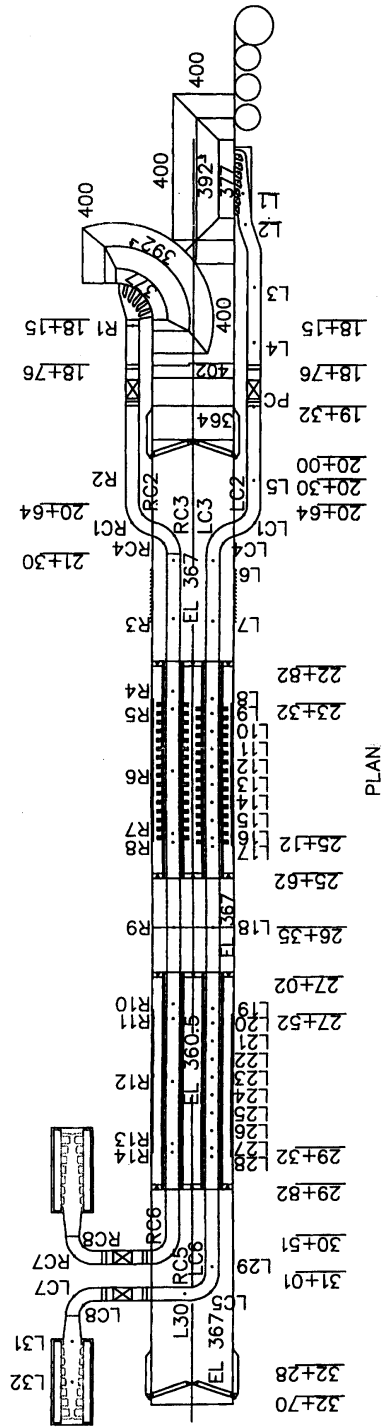

PLAN

PIEZOMETER LOCATIONS
 TYPE 1 FILLING AND EMPTYING SYSTEM

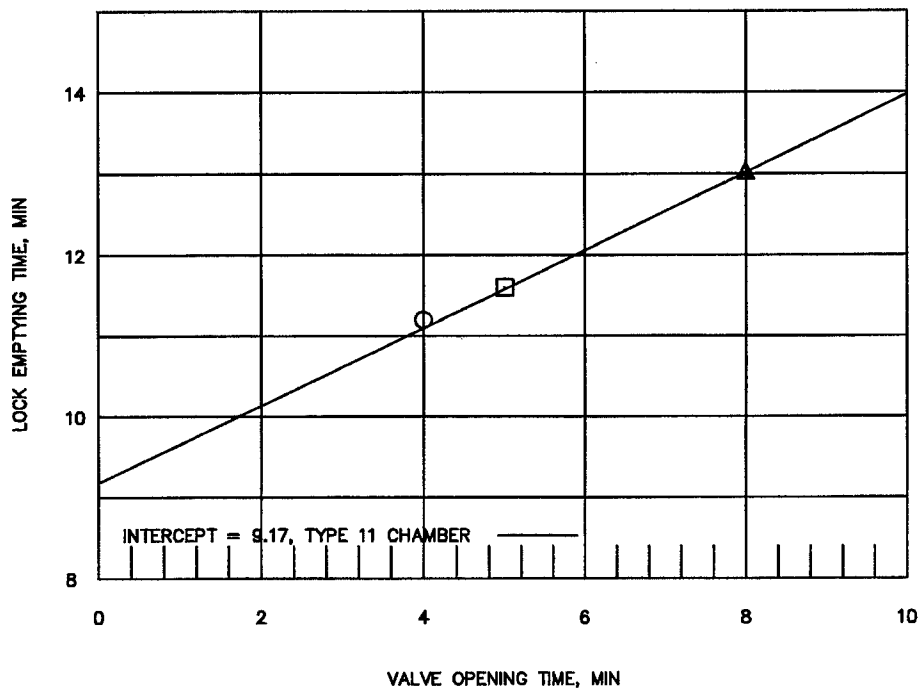
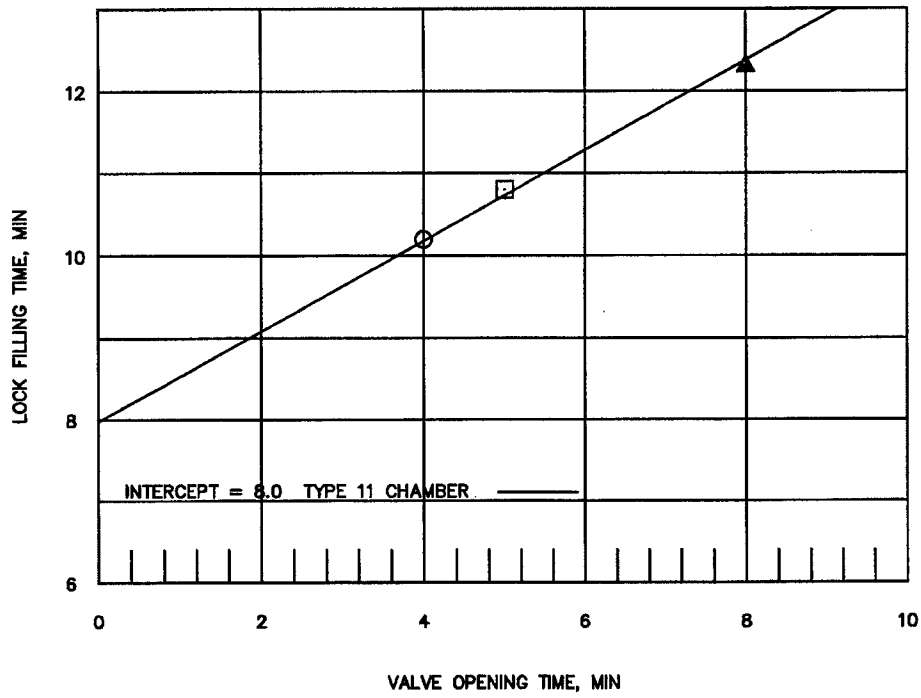

OPERATING CONDITIONS
37 FT LIFT

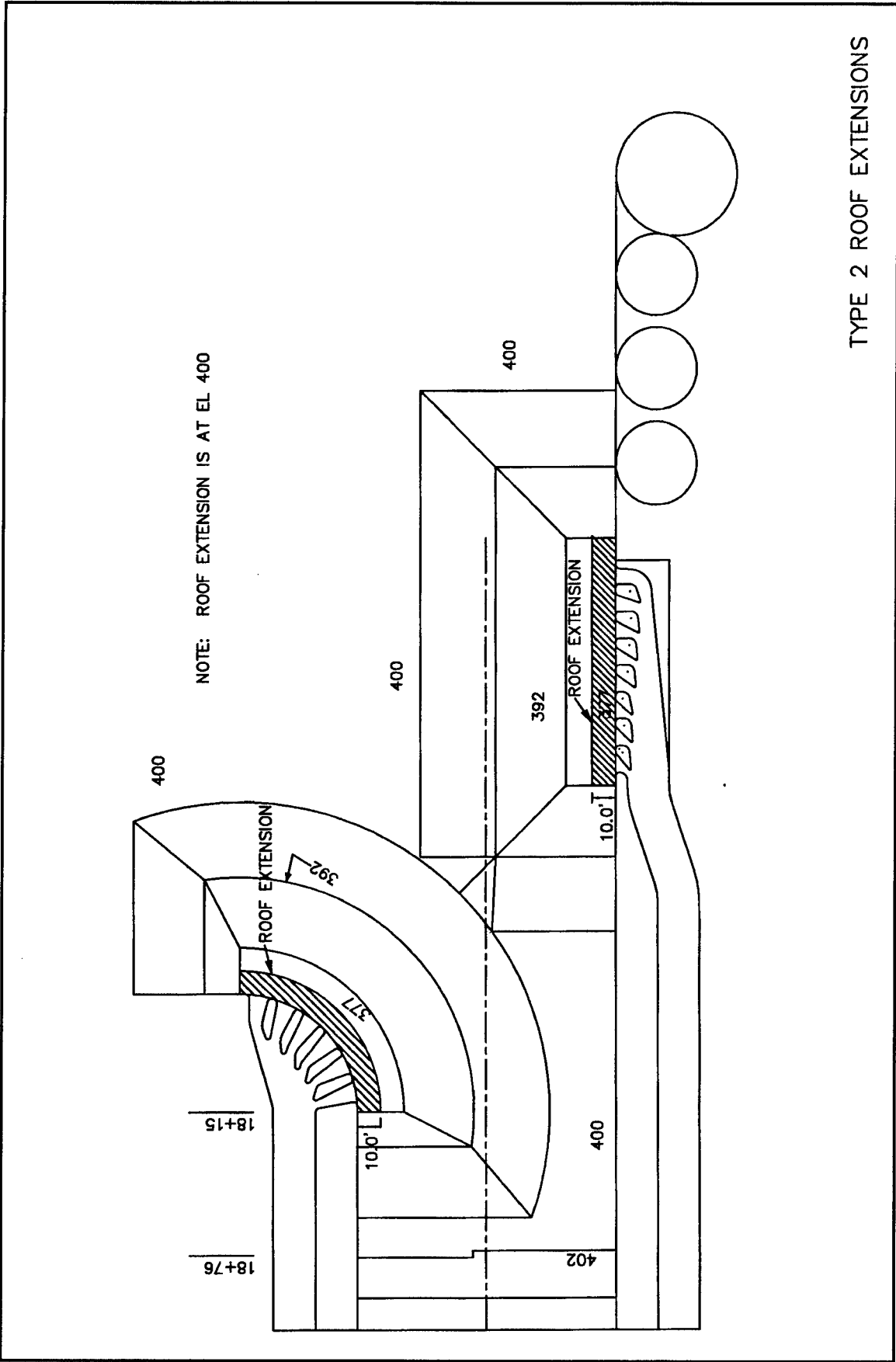

TYPE 2 ROOF EXTENSIONS

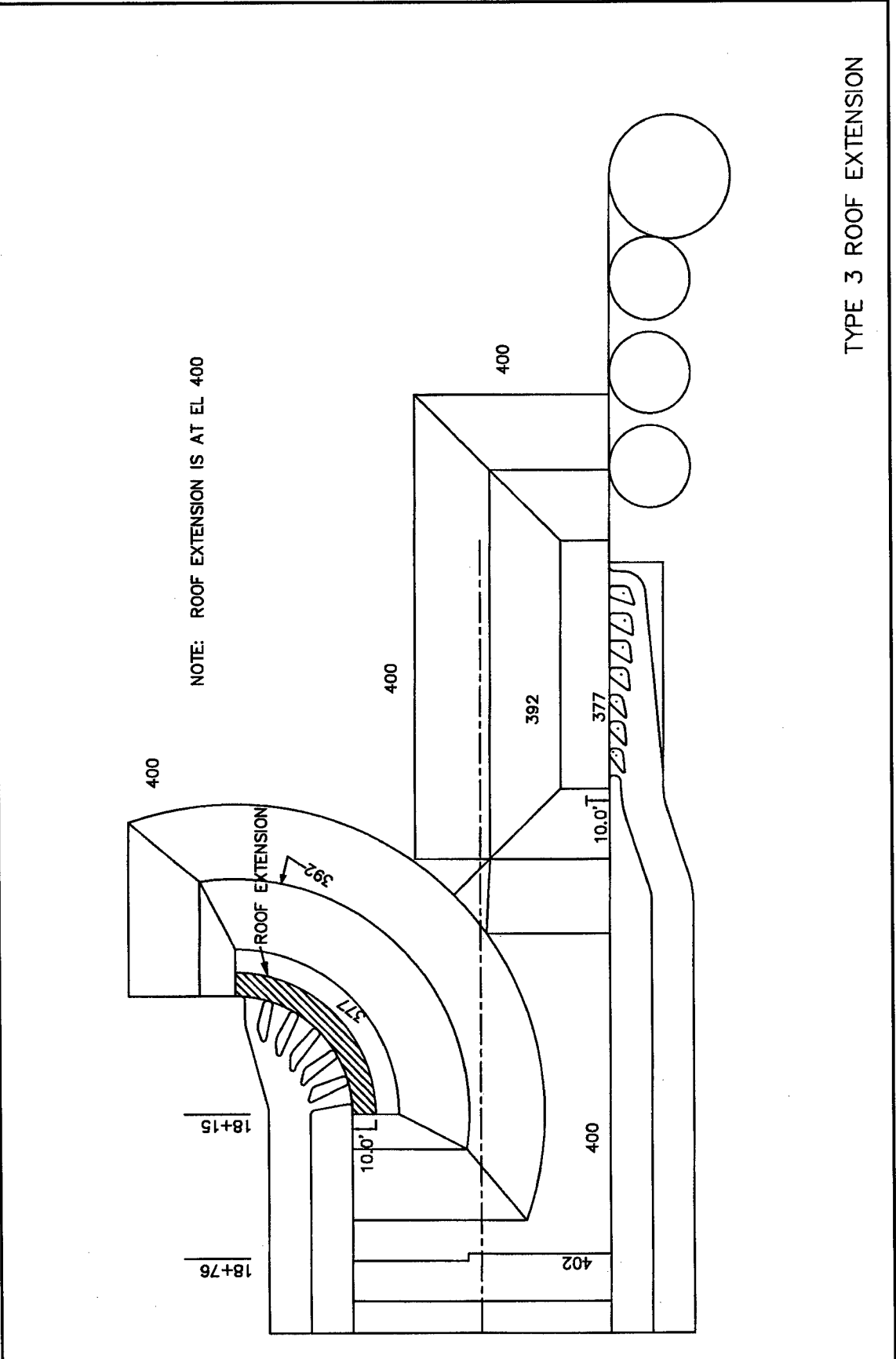

TYPE 3 ROOF EXTENSION

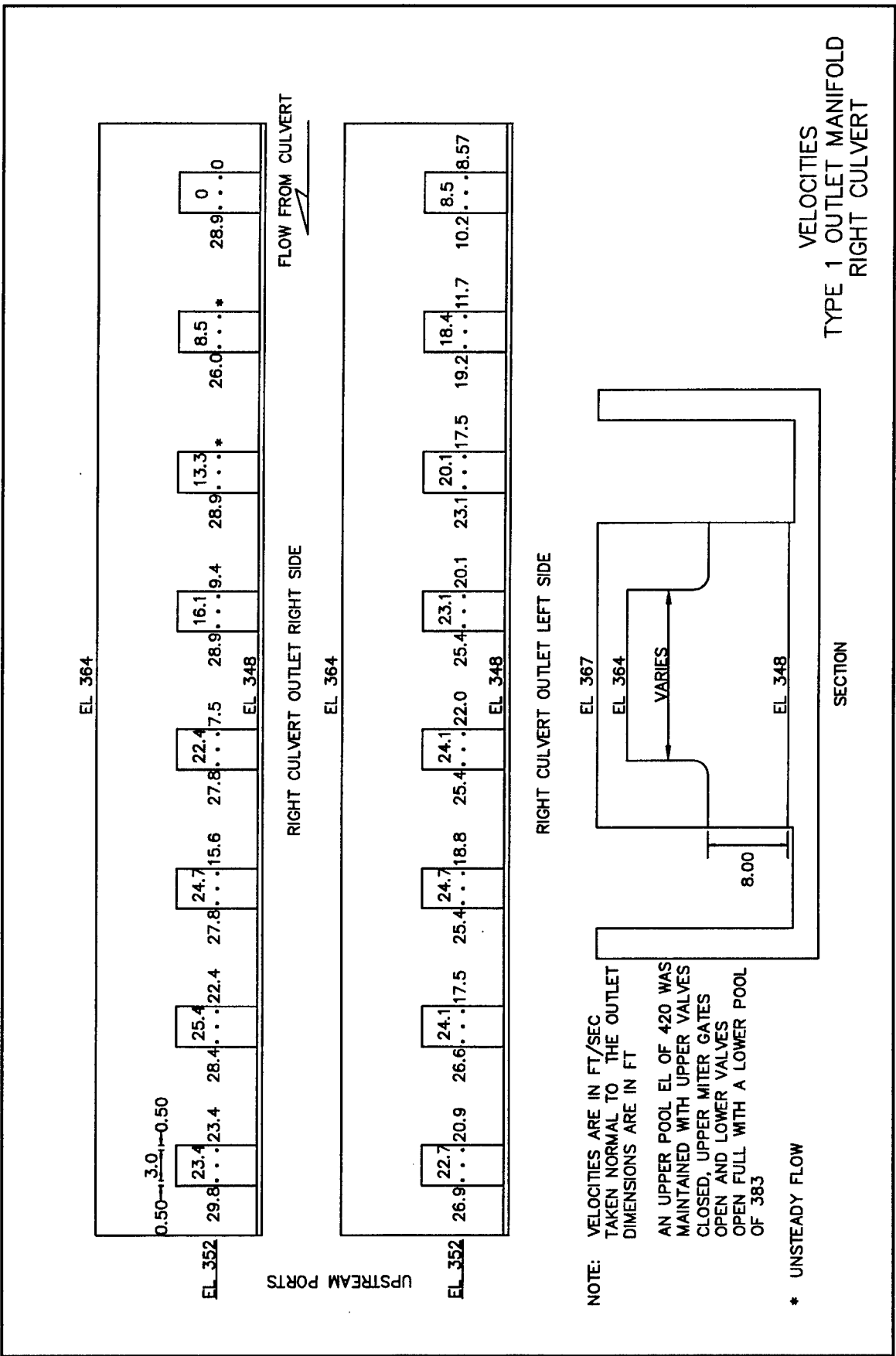

EL 364

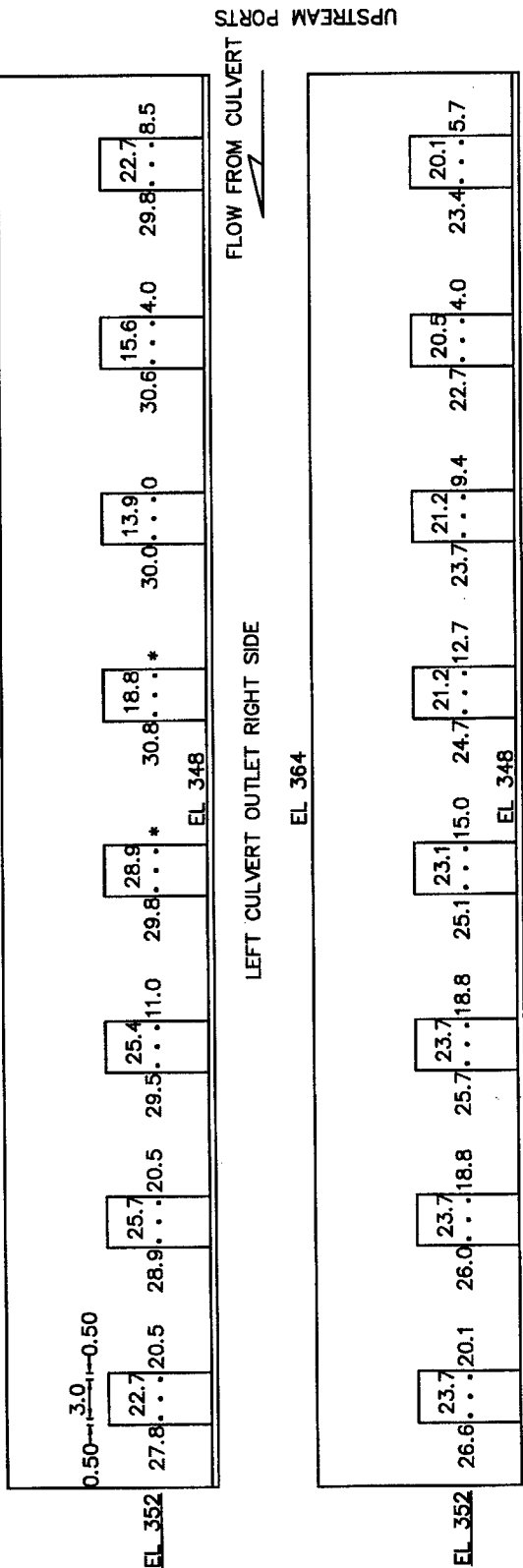

NOTE: VELOCITIES ARE IN FT/SEC
 TAKEN NORMAL TO THE OUTLET
 DIMENSIONS ARE IN FT

AN UPPER POOL OF 420 WAS
 MAINTAINED WITH UPPER VALVES
 CLOSED, UPPER MITER GATES
 OPEN AND LOWER VALVES
 OPEN FULL WITH A LOWER POOL
 EL OF 383

* UNSTEADY FLOW

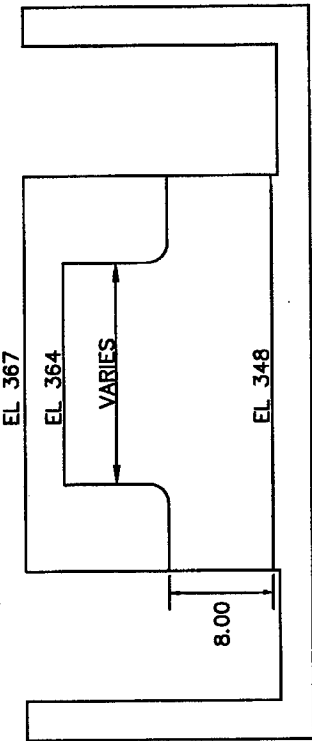

VELOCITIES
 TYPE 1 OUTLET MANIFOLD
 LEFT CULVERT

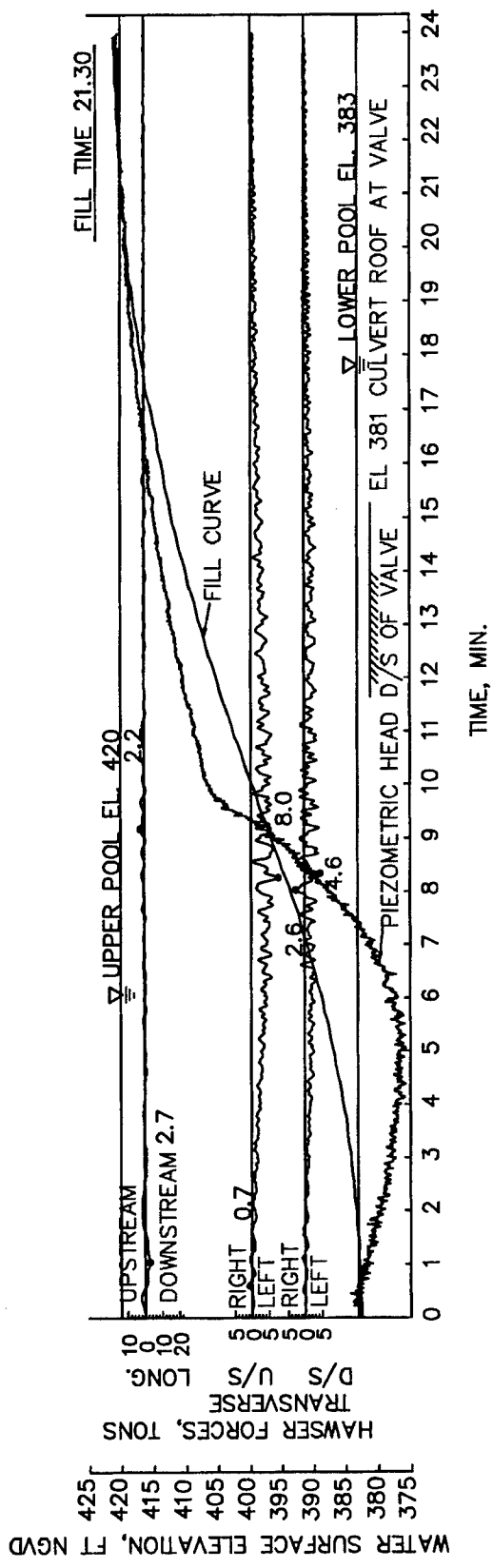

FILLING CHARACTERISTICS
 TYPE 11 CHAMBER DESIGN
 LEFT 10 MIN SINGLE VALVE OPERATION - TEST 1

10F001

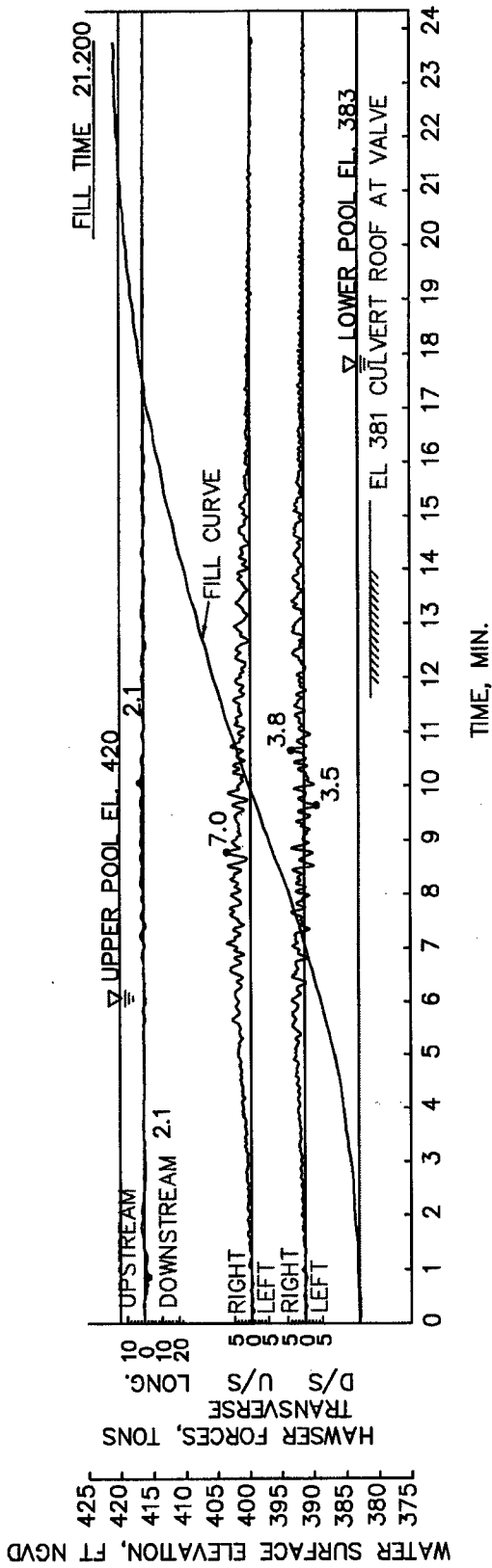

FILLING CHARACTERISTICS
 TYPE 11 CHAMBER DESIGN
 RIGHT 10 MIN SINGLE VALVE OPERATION - TEST 1

10FL001

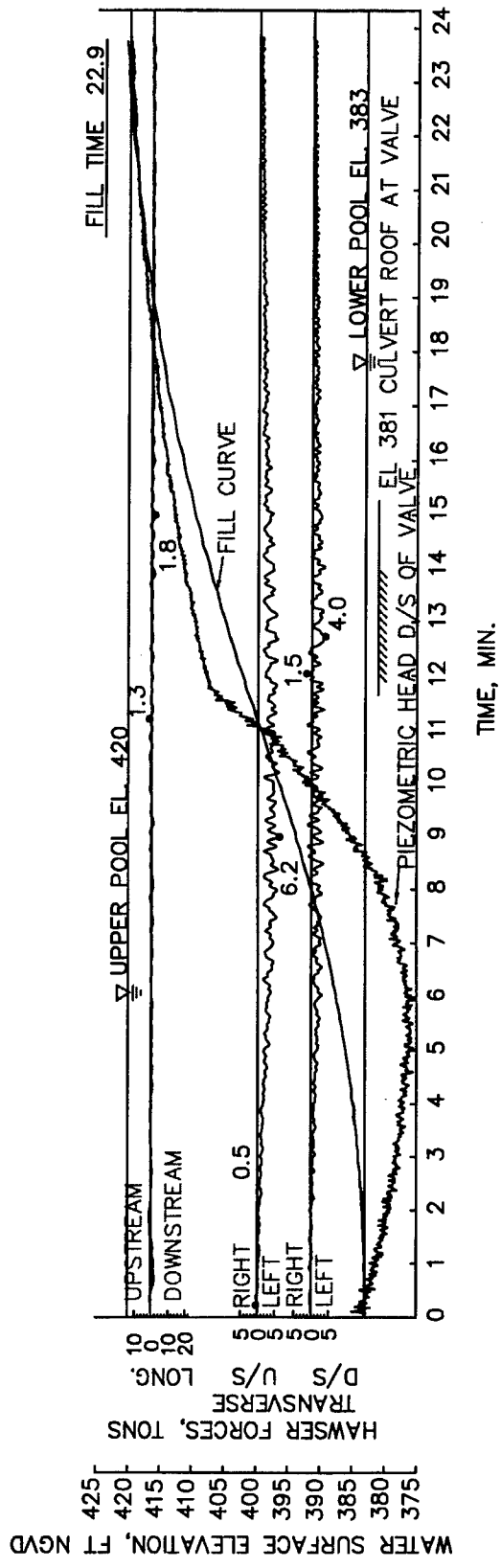

FILLING CHARACTERISTICS
 TYPE 11 CHAMBER DESIGN
 LEFT 12 MIN SINGLE VALVE OPERATION - TEST 2

12F.004

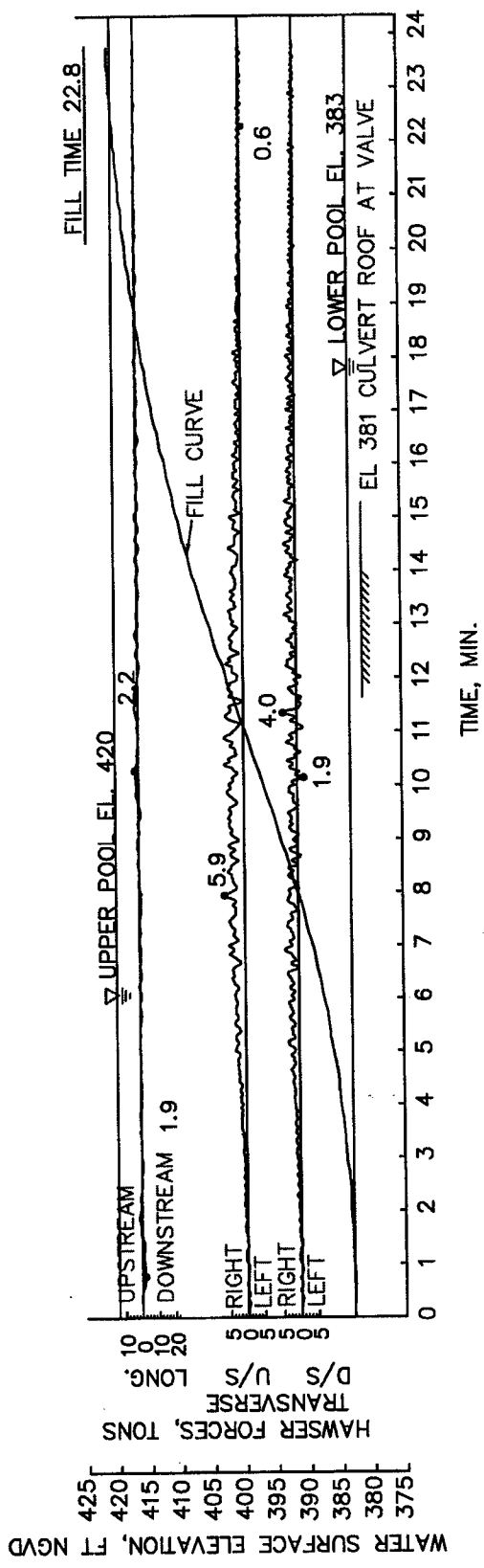

FILLING CHARACTERISTICS
 TYPE 11 CHAMBER DESIGN
 RIGHT 12 MIN SINGLE VALVE OPERATION - TEST 1

12FL001

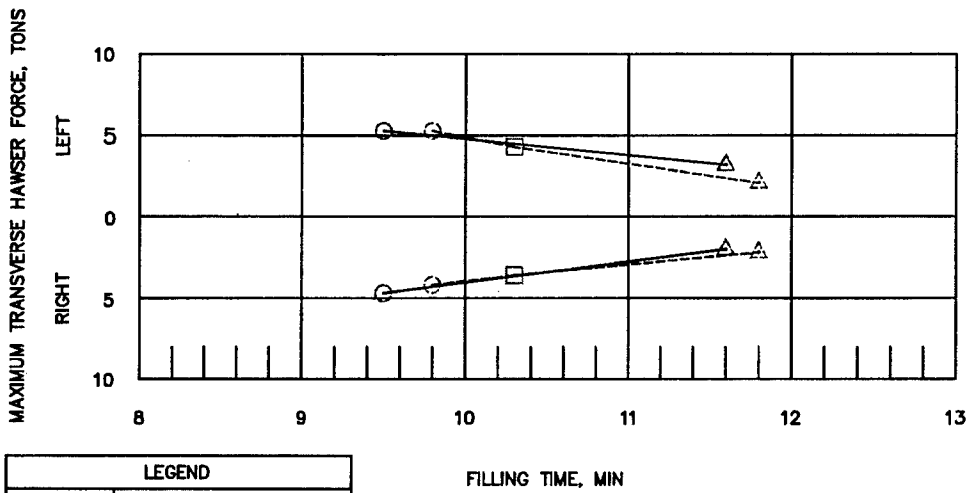
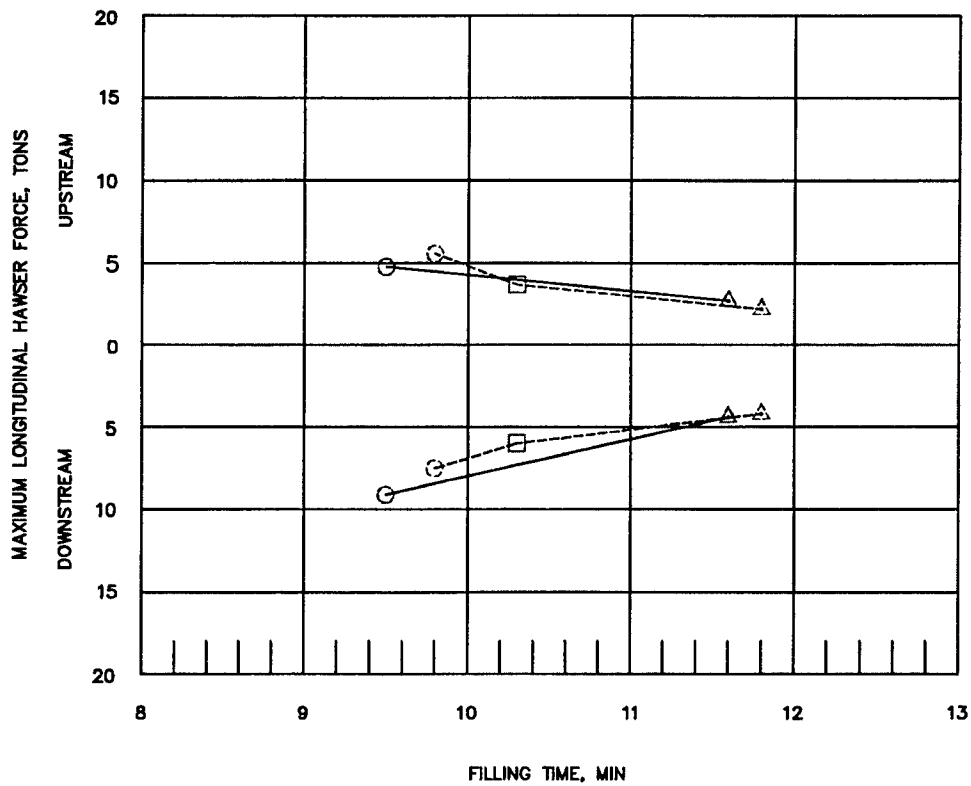

LEGEND	
○	VALVE SCHEDULE, MIN 4
□	5
△	8
LINE TYPE SUBMERGENCE, FT	
—	19
- - -	24

NOTE: SUBMERGENCE IS FROM LOWER POOL TO TOP OF PORT (EL 364)

HAWSER FORCES
DURING FILLING
TYPE 11 CHAMBER DESIGN
30 FT LIFT

REPORT DOCUMENTATION PAGE

Form Approved
OMB No. 0704-0188

Public reporting burden for this collection of information is estimated to average 1 hour per response, including the time for reviewing instructions, searching existing data sources, gathering and maintaining the data needed, and completing and reviewing the collection of information. Send comments regarding this burden estimate or any other aspect of this collection of information, including suggestions for reducing this burden, to Washington Headquarters Services, Directorate for Information Operations and Reports, 1215 Jefferson Davis Highway, Suite 1204, Arlington, VA 22202-4302, and to the Office of Management and Budget, Paperwork Reduction Project (0704-0188), Washington, DC 20503.

1. AGENCY USE ONLY (Leave blank)		2. REPORT DATE September 2000	3. REPORT TYPE AND DATES COVERED Final report	
4. TITLE AND SUBTITLE New McAlpine Lock Filling and Emptying System, Ohio River, Kentucky; Hydraulic Model Investigation			5. FUNDING NUMBERS	
6. AUTHOR(S) John E. Hite, Jr.				
7. PERFORMING ORGANIZATION NAME(S) AND ADDRESS(ES) U.S. Army Engineer Research and Development Center Coastal and Hydraulics Laboratory 3909 Halls Ferry Road, Vicksburg, MS 39180-6199			8. PERFORMING ORGANIZATION REPORT NUMBER ERDC/CHL TR-00-24	
9. SPONSORING/MONITORING AGENCY NAME(S) AND ADDRESS(ES) U.S. Army Engineer District, Louisville P.O. Box 59 Louisville, KY 40201-0059			10. SPONSORING/MONITORING AGENCY REPORT NUMBER	
11. SUPPLEMENTARY NOTES				
12a. DISTRIBUTION/AVAILABILITY STATEMENT Approved for public release; distribution is unlimited			12b. DISTRIBUTION CODE	
13. ABSTRACT (Maximum 200 words) <p>Navigation improvements at McAlpine Locks and Dam on the Ohio River include construction of another 365.76-m- (1,200-ft-) long lock chamber adjacent to the existing lock chamber. A previous model investigation of an in-chamber longitudinal culvert filling and emptying system (ILCS) with through-the-sill intakes and outlets revealed the ILCS design was feasible. The intake and outlet designs were changed and another model study, reported herein, was conducted to evaluate the hydraulic performance of the new design. The ILCS design was modified slightly from the previous study. Port extensions were added to some of the ports in the lower half of the chamber and the width of the wall baffle was increased. The filling time for acceptable chamber performance with these changes and the design lift, 11.28 m (37 ft), was 11.3 min. This filling time was achieved with a variable speed valve operation. A roof extension placed over the right intake was found to be beneficial in helping to reduce the strength of vortices that formed in the upper approach during filling operations.</p>				
14. SUBJECT TERMS In-chamber longitudinal culvert filling and emptying system (ILCS) Intake vortices Lock design			Lock filling and emptying culverts McAlpine Locks and Dam project Ohio River	
			15. NUMBER OF PAGES 112	
			16. PRICE CODE	
17. SECURITY CLASSIFICATION OF REPORT UNCLASSIFIED	18. SECURITY CLASSIFICATION OF THIS PAGE UNCLASSIFIED	19. SECURITY CLASSIFICATION OF ABSTRACT	20. LIMITATION OF ABSTRACT	