

LOAN DOCUMENT

PHOTOGRAPH THIS SHEET

DTIC ACCESSION NUMBER

LEVEL

INVENTORY

OPERATIONS AND MAINTENANCE MANUAL ...

DOCUMENT IDENTIFICATION

AUG 96

DISTRIBUTION STATEMENT A
Approved for Public Release
Distribution Unlimited

DISTRIBUTION STATEMENT

ACCESSION BY	
NTIS	GRAM <input type="checkbox"/>
DTIC	TRAC <input type="checkbox"/>
UNANNOUNCED	<input type="checkbox"/>
JUSTIFICATION	<input type="checkbox"/>
BY	
DISTRIBUTION/	
AVAILABILITY CODES	
DISTRIBUTION	AVAILABILITY AND/OR SPECIAL
A-1	

DISTRIBUTION STAMP

DATE ACCESSIONED

DATE ACCESSIONED

DATE RETURNED

DATE RETURNED

REGISTERED OR CERTIFIED NUMBER

REGISTERED OR CERTIFIED NUMBER

20001215 092

DATE RECEIVED IN DTIC

PHOTOGRAPH THIS SHEET AND RETURN TO DTIC-FDAC

H
A
N
D
L
E

W
I
T
H

C
A
R
E

**Operations and Maintenance Manual for
Pilot-Scale Bioventing System at the
Closed Waste POL Pit, SWMU 14
Fort Rucker, Alabama**

Prepared For



**The US Army Environmental Center
Aberdeen Proving Ground, Maryland**

Fort Rucker, Alabama

and



**Air Force Center for Environmental Excellence
Brooks Air Force Base
San Antonio, Texas**

August 1996



**PARSONS
ENGINEERING SCIENCE, INC.**

1700 Broadway, Suite 900 • Denver Colorado 80290

AQM01-03-0548

DEFENSE TECHNICAL INFORMATION CENTER
REQUEST FOR SCIENTIFIC AND TECHNICAL REPORTS

Title AFCOE Collection

1. Report Availability (Please check one box)

- This report is available. Complete sections 2a - 2f.
- This report is not available. Complete section 3.

2a. Number of Copies Forwarded

each

2b. Forwarding Date

July/2000

2c. Distribution Statement (Please check ONE box)

DoD Directive 5230.24, "Distribution Statements on Technical Documents," 18 Mar 87, contains seven distribution statements, as described briefly below. Technical documents MUST be assigned a distribution statement.

- DISTRIBUTION STATEMENT A: Approved for public release. Distribution is unlimited.
- DISTRIBUTION STATEMENT B: Distribution authorized to U.S. Government Agencies only.
- DISTRIBUTION STATEMENT C: Distribution authorized to U.S. Government Agencies and their contractors.
- DISTRIBUTION STATEMENT D: Distribution authorized to U.S. Department of Defense (DoD) and U.S. DoD contractors only.
- DISTRIBUTION STATEMENT E: Distribution authorized to U.S. Department of Defense (DoD) components only.
- DISTRIBUTION STATEMENT F: Further dissemination only as directed by the controlling DoD office indicated below or by higher authority.
- DISTRIBUTION STATEMENT X: Distribution authorized to U.S. Government agencies and private individuals or enterprises eligible to obtain export-controlled technical data in accordance with DoD Directive 5230.25, Withholding of Unclassified Technical Data from Public Disclosure, 6 Nov 84.

2d. Reason For the Above Distribution Statement (in accordance with DoD Directive 5230.24)

2e. Controlling Office

HQ AFCEE

2f. Date of Distribution Statement Determination

15 Nov 2000

3. This report is NOT forwarded for the following reasons. (Please check appropriate box)

- It was previously forwarded to DTIC on _____ (date) and the AD number is _____
- It will be published at a later date. Enter approximate date if known. _____
- In accordance with the provisions of DoD Directive 3200.12, the requested document is not supplied because: _____

Print or Type Name

Laura Peña

Telephone

210-536-1431

Signature

Laura Peña

AQ Number

M01-03-0548

CONTENTS

	<u>Page</u>
SECTION 1 - INTRODUCTION	1-1
SECTION 2 - SYSTEM DESCRIPTION	2-1
2.1 Blower System	2-1
2.2 Monitoring and Flow Control Equipment	2-1
2.2.1 Monitoring Gauges	2-1
2.2.2 Flow Control Equipment	2-1
SECTION 3 - SYSTEM MAINTENANCE	3-1
3.1 Blower/Motor	3-1
3.2 Air Filter	3-1
3.3 Maintenance Schedule	3-1
3.4 Major Repairs	3-2
SECTION 4 - SYSTEM MONITORING	4-1
4.1 Blower Performance Monitoring	4-1
4.1.1 Vacuum/Pressure	4-1
4.1.2 Temperature	4-1
4.2 Monitoring Schedule	4-1
4.3 Reporting Monitoring Results	4-1
APPENDIX A Regenerative Blower Information	
APPENDIX B Data Collection Sheets	

SECTION 1

INTRODUCTION

This Operations and Maintenance (O&M) Manual has been created as a guide for monitoring and maintaining the performance of the pilot-scale bioventing blower system and vent well plumbing at Fort Rucker, Alabama.

Bioventing is the forced injection of fresh air, or withdrawal of soil gas, to enhance the supply of oxygen in subsurface soils for *in situ* bioremediation. A blower system is used to inject air into the soil, thereby supplying fresh atmospheric air (with approximately 20.8 percent oxygen) to contaminated soils. Once oxygen is provided to the subsurface, existing bacteria aerobically break down fuel residuals. Aerobic biodegradation is much more efficient than anaerobic biodegradation which occurs in oxygen depleted soils.

Parsons Engineering Science, Inc. (Parsons ES) has installed an air injection bioventing system consisting of an air injection blower, two vent wells (VWs), four soil gas monitoring points (MPs), and associated piping at the site. The blower and VWs at SWMU 14 was installed May 14-15, 1996 for a bioventing pilot test during the period from May 14 through May 22, 1996. The air injection rates of the expanded bioventing system were optimized at each vent well to assure adequate aeration of contaminated soils to promote aerobic biodegradation.

Fort Rucker personnel are responsible for routine monitoring of the bioventing system. Parsons ES has trained Fort Rucker personnel on the maintenance requirements of this plan. If significant problems are encountered with the operation of the system, Parsons ES should be notified so repairs can be made. Under the Extended Bioventing Project Option 1, Parsons ES is responsible for system repair for a 1-year period after system startup. Should the bioventing system cease to operate or develop a significant problem, please call the Parsons ES Site Manager, Mr. John Hall, at (970) 244-8829. If the system ceases to operate, please have a base electrician verify that adequate power is being supplied to the bioventing system blower motor prior to notifying Parsons ES.

SECTION 2

SYSTEM DESCRIPTION

2.1 BLOWER SYSTEM

A Gast® R5 blower powered by a 2-horsepower direct-drive motor was installed at SWMU 14 in May 1996. The R5 blower is rated as having a maximum flow rate of 160 scfm at open flow and a maximum pressure of 65 inches of water. Approximately 20 acfm are being injected into each VW and the balance is being bled to the atmosphere. The blower systems include inlet air filters to remove any particulates which are entrained in the inlet air stream and several valves and monitoring gauges which are described in Section 2.2. A schematic of the full-scale blower system installed at SWMU 14 is shown in the pilot test results report provided to the base. Corresponding blower performance curves and relevant service information are provided in Appendix A.

2.2 MONITORING AND FLOW CONTROL EQUIPMENT

2.2.1 Monitoring Gauges

The bioventing system is equipped with vacuum, pressure, and temperature gauges, and air velocity measurement ports. Gauges have been installed on the air injection system at the following locations: a vacuum gauge in the inlet piping and pressure and temperature gauges in the outlet piping.

2.2.2 Flow Control Equipment

Manual and automatic flow control valves (FCVs) have been installed on the bioventing blower system. Manual FCVs have been installed in the piping leading to each VW to enable the flow rate to each VW to be adjusted individually. An automatic FCV, or pressure relief valve (PRV), is used to protect the blower systems from burning out if pressures rise due to pipe blockage. The PRV is set to bleed off flow at a preset pressure and thus prevent blower outlet pressure from ever exceeding the rated pressure.

An additional FCV (bleed valve) has been installed to control the total air flow out of the blower by releasing excess air flow to the atmosphere. The FCVs have been set by Parsons ES personnel to deliver a calculated amount of air to each VW and should not be adjusted unless directed to do so by Parsons ES personnel.

The blower system has also been equipped with flow measurement ports. These ports consist of brass bushings installed in the outlet piping leading to each VW. These bushings,

which should be plugged during system operation, allow the insertion of a thermal anemometer for the measurement of air velocity. These ports are used by Parsons ES for system optimization.

Although the blower system installed at SWMU 14 is relatively maintenance free, periodic system maintenance is required for proper operation and long life. Recommended maintenance procedures and schedule are described in detail in the instruction manuals included in Appendix A and briefly summarized in this section.

Filter inspection must be performed with the system turned off. Do not change the flow control valve settings (valves have been pre-set for a specific flow rate) before re-starting the blower.

SECTION 3

SYSTEM MAINTENANCE

3.1 BLOWER/MOTOR

The blower and motor are relatively maintenance free and should not require any maintenance during the operational period. Both the blower and motor have sealed bearings and do not require lubrication.

3.2 AIR FILTER

To avoid damage caused by passing solids through the blower, an air filter has been installed in-line before the blower. The paper filter element is accompanied by a polyurethane foam pre-filter. The filter should be checked weekly for the first 2 months of operation. A facility employee should determine the best schedule for filter replacement based on the first 2 months of system monitoring. The polyurethane pre-filters can be washed with lukewarm water and a mild detergent. Paper filter elements should never be washed, and should be disposed of and replaced as necessary. When the vacuum drop across the filter increases by approximately 10 inches of water from the vacuum when the filter was new, a dirty filter element should be suspected, and cleaning or replacement should be performed. The initial vacuum when the filter element was new was 9 inches of water. Therefore, the filter should be cleaned or replaced when the vacuum increases to 19 inches of water. Typical filter element replacement intervals range from 3 to 6 months.

To remove the filter, turn the system off by pushing the stop button on the starter, loosen the three clamps or the wing nut on the filter top, lift the metal top off the air filter, and lift the air filter element from the metal housing. Remove the polyurethane pre-filter (if applicable) and wash before replacing.

The filter element is manufactured by Solberg Manufacturing, Inc. in Itasca, Illinois. Their telephone number is (708) 773-1363. Additional filters can also be obtained through Parsons ES. The Parsons ES contacts are Mr. John Hall (970) 244-8829 and Mr. Troy Marcella (504) 293-6680. The part number for the replacement filter element is 30P. Four spare air filter elements have been placed inside the blower enclosure.

3.3 MAINTENANCE SCHEDULE

The following maintenance schedule is recommended for the blower system. During the initial few months of operation more frequent monitoring is recommended to ensure that any startup problems are quickly corrected. A daily drive-by inspection is recommended during

the initial 2 weeks of operation to ensure that the blower system is still operating with no unusual sounds. Thereafter monitoring inspections every 2 weeks are recommended (see Section 4). Preprinted data collection sheets have been provided to the facility. Extra data collection sheets for recording maintenance activities are provided in Appendix B.

<u>Maintenance Item</u>	<u>Maintenance Frequency</u>
Filter	Check once every 2 weeks, wash or replace as necessary (see Section 3.3). Inlet vacuum exceeding 19 inches of water indicates that the filter requires cleaning or replacement.

3.4 MAJOR REPAIRS

Blowers systems are very reliable when properly maintained. Occasionally, however, a motor or blower will develop a serious problem. If a blower system fails to start, and a qualified electrician verifies that power is available at the blower or starter, Parsons ES should be contacted to arrange for repairs. The Parsons ES contacts are Mr. John Hall (970) 244-8829 and Mr. Troy Marcella (504) 293-6680. Parsons ES is responsible for major repairs during the first year of operation.

SECTION 4

SYSTEM MONITORING

4.1 BLOWER PERFORMANCE MONITORING

To monitor the blower performance, the vacuum, pressure, and temperature will be measured. These data should be recorded every 2 weeks on a data collection sheet (provided in Appendix B). All measurements should be taken at the same time while the system is running. Because the system is noisy, hearing protection should be worn at all times.

4.1.1 Vacuum/Pressure

With hearing protection in place, unlock and open the blower enclosure and record all vacuum and pressure readings directly from the gauges (in inches of water). Record the measurements on the data collection sheet.

4.1.2 Temperature

With hearing protection in place, open the blower enclosure and record the temperature readings directly from the gauges in degrees Fahrenheit (°F). Record the measurements on a data collection sheet (provided in Appendix B). The temperature change can be converted to degrees Celsius (°C) using the formula $^{\circ}\text{C} = (^{\circ}\text{F} - 32) \times 5/9$.

4.2 MONITORING SCHEDULE

The following monitoring schedule is recommended for these systems. During the initial month of operation, more frequent monitoring is recommended to ensure that any start up problems are quickly corrected. Data collection sheets have been provided to assist your data collection and are included in Appendix B.

<u>Monitoring Item</u>	<u>Monitoring Frequency</u>
Vacuum/Pressure	Once every 2 weeks.
Temperature	Once every 2 weeks.

4.3 REPORTING MONITORING RESULTS

System monitoring data sheets should be faxed to the Parsons ES Site Manager, Mr. John Hall, once every 2 months. However, if a significant change in the system temperature or

pressure is noted (such as a significant drop or increase in pressure) please call (970) 244-8829 immediately. A significant change in system temperature or pressure may be indicative of a problem with the air delivery system or blower.

APPENDIX A

REGENERATIVE BLOWER INFORMATION



Post Office Box 97
Benton Harbor, Michigan 49023-0097
Ph: 616/926-6171
Fax: 616/925-8288

Maintenance Instructions for Gast Standard Regenerative Blowers

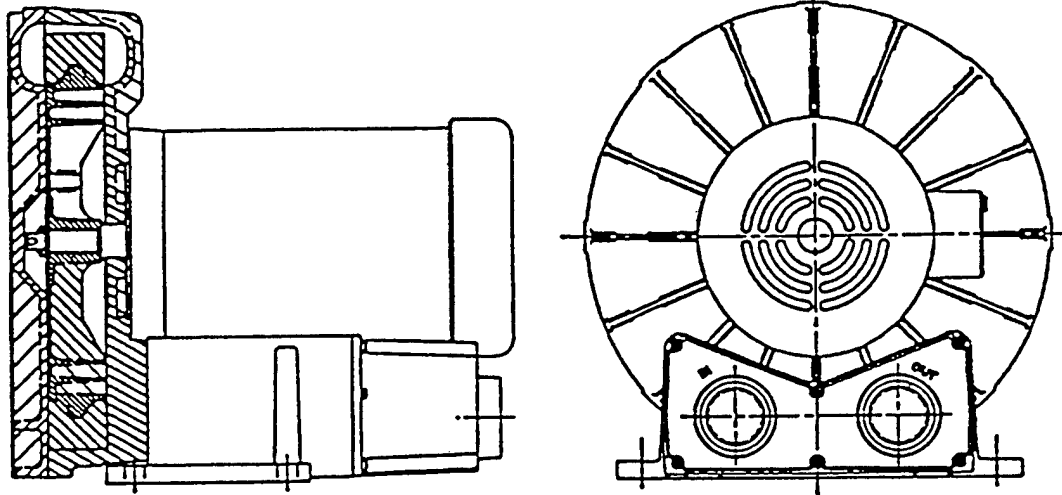

For original equipment manufacturers
special models, consult your local distributor

Gast Rebuilding Centers

Gast Mfg. Corp.
2550 Meadowbrook Rd.
Benton Harbor MI. 49022
Ph: 616/926-6171
Fax: 616/925-8288

Gast Mfg Corp.
505 Washington Avenue
Carlstadt, N. J. 07072
Ph: 201/933-8484
Fax: 201/933-5545

Brenner Fiedler. & Assoc.
13824 Bentley Place
Cerritos, CA. 90701
Ph: 213/404-2721
Fax: 213/404-7975

Wainbee, Limited
121 City View Drive
Toronto, Ont. Canada M9W 5A9
Ph: 416/243-1900
Fax: 416/243-2336

Wainbee, Limited
215 Brunswick Drive
Pointe Claire, P.Q. Canada H9R 4R7
Ph: 514/697-8810
Fax: 514/697-3070

Gast Mfg. Co. Limited.
Hallfax Rd, Cressex Estate
High Wycombe, Bucks HP12 3SN
Ph. 44 494 523571
Fax: 44 494 436588

Japan Machinery Co. Ltd.
Central PO Box 1451
Tokyo 100-91 Japan
Ph: 813/3573-5421
Fax: 813/3571-7865

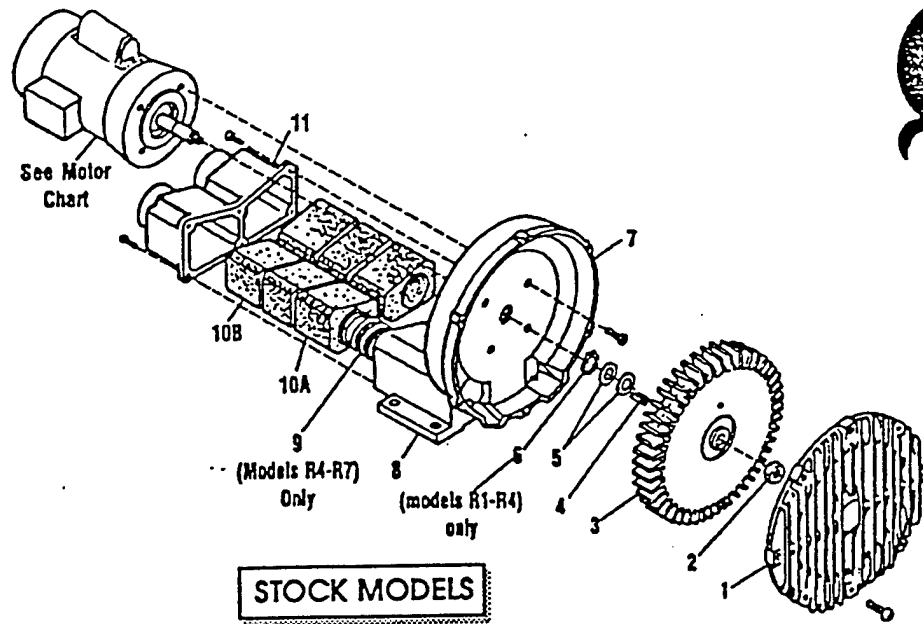

STOCK MODELS

Part Name	R1	R2	R3	R4	R5	R6	R6P	R6PP/R6PS	R7
#1 Cover	AJ101A	AJ101B	AJ101C	AJ101D	AJ101EQ	AJ101F	AJ101K	(2)AJ101KA	AJ101G
#2 Stopnut	BC187	BC187	BC181	BC181	BC181	BC181	BC181	(2)BC182	BC183
#3 Impeller	AJ102A	AJ102BQ	AJ102C	AJ102D	AJ102E	AJ102FR	AJ102K	(2)AJ102KA	AJ102GA
#4 Square Key	AH212C	AH212	AB136A	AB136D	AB136	AB136	AB136	(2)AB136	AC628
#5 Shim Spacer (s)	AJ132	AE686-3	AJ109	AJ109	AJ109	AJ116A	AJ116A	AJ116A	AJ110
#6 Retaining Ring	AJ145	AJ145	AJ149	AJ149					
#7 Housing	AJ103A	AJ103BQ	AJ103C	AJ103DR	AJ103E	AJ103F	AJ103K	AJ103KD	AJ103GA
#8 Muffler Box					AJ104E	AJ104F			
#9 Spring				AJ113DR	AJ113DQ	AJ113FQ	AJ113FQ		AJ113G
#10A Foam	(4)AJ112A	(4)AJ112B	(4)AJ112C	(4)AJ112DS	(4)AJ112ER	(6)AJ112F	(8)AJ112K		(8)AJ112GA
#10B Foam		(2)AJ112BQ	(2)AJ112CQ	(2)AJ112DR	(2)AJ112EQ				
#11 Muffler Extension/ Adaptor Plate	AJ106H	AJ106BQ	AJ106CQ	AJ106DQ	AJ106EQ	AJ106EQ	AJ104K		AJ104GA
Shim Kit	K396	K396							K395

MOTOR CHART

REGENAIR MODEL NUMBER	MOTOR NUMBER	MOTOR SPECIFICATIONS		PHASE
		60 HZ VOLTS	50 HZ VOLTS	
R1102	J111X	115/208-230	110/220-240	1
R1102C	J112X	115		1
R2103	J311X	115/208-230	110/220	1
R2105	J411X	115/208-230	110/220	1
R2303A	J310	208-230/460	220/380-415	3
R2303F	J313	208-230	220	3
R3105-1/R3105-12	J411X	115/208-230	110/220-240	1
R3305A-1/R3305A-13	J410	208-230/460	220/380-415	3
R4110-2	J611AX	115/208-230	110/220-240	1
R4310A-2	J610	208-230/460	220/380-415	3
R5125-2	J811X	115/208-230		1
R5325A-2	J810X	208-230/460	220/380-415	3
R6125-2	J811X	115/208-230		1
R6325A-2	J810X	208-230/460	220/380-415	3
R6335A-2	J910X	208-230/460	220/380-415	3
R6150J-2	J1013	230		1
R6350A-2	J1010	208-230/460	220/380-415	3
R6P335A	J910X	208-230/460	220/380-415	3
R6P350A	J1010	208-230/460	220/380-415	3
R6P355A	J110A	208-230/460	220/380-415	3
R7100A-2	J1210B	208-230/460	220/380-415	3
R6PP/R6PS110M	JD1100	208-230/460	220/380-415	3

* No lubrication needed at start up. Bearings lubricated at factory.

* Motor is equipped with alemite fitting. Clean tip of fitting and apply grease gun. Use 1 to 2 strokes of high quality ball bearing grease.

<i>Consistency</i>	<i>Type</i>	<i>Typical Grease</i>
Medium	Lithium	Shell Doltum R

<i>Hours of service per year</i>	<i>Suggested Relube Interval</i>
5,000	3 years
Continual Normal Application	1 year
Seasonal service motor idle for 6 months or more	1 year beginning of season 6 months

Continuous-high ambient, dirty or moist applications.

All performance figures relate to stock models. A few high pressure units may be available. Consult your local distributor.

Regenair Model Number	PRESSURE						Maximum Pressure "H ₂ O"
	0"H ₂ O	20"H ₂ O	40"H ₂ O	60"H ₂ O	80"H ₂ O	100"H ₂ O	
R1	26	14					28
R2	42	26					38
R3105-1	52	38	14				42
R3105-12	52	36	23				55
R3305A-13	52	36	23				55
R4	90	70	50				52
R5	145	130	100				65
R6125-2	200	180					35
R6325A-2	200	180	152				40
R6335A-2	205	175	155	135			70
R6350A-2	200	180	150	130	110	80	105
R6P335A	250	250					30
R6P350A	300	260	230	200			60
R6P355A	300	260	230	200	160		90
R7100A-2	420	380	340	310	280	230	115
R6PP311OM	485	452	420	380	330		95
R6PS311OM	265	258	252	244	236	226	170

Regenair Model Number	VACUUM						Maximum Vacuum "H ₂ O"
	0"H ₂ O	20"H ₂ O	40"H ₂ O	60"H ₂ O	80"H ₂ O		
R1	25	14					26
R2	40	22					34
R3105-1	50	34	9				40
R3105-12	51	34	20				50
R3305A-13	51	34	20				50
R4	82	62	39				48
R5	140	115	90	50			60
R6125-2	190	155	125				45
R6325A-2	190	155	125				45
R6335A-2	190	150	125	100			75
R6350A-2	190	180	150	100	70		90
R6P335A	270	230					37
R6P350A	280	240	210	170			70
R6P355A	280	240	210	170	100		86
R7100A-2	410	350	300	250	170		90
R6PP311OM	470	425	375	320	220		80
R6PS311OM	240	225	210	195	175		130

*This number indicates the maximum static pressure differential recommended (with cooling air still flowing through unit). In general, units 1hp or less can be dead headed. Check with local representative or distributor to verify which models apply.

Operation of the blower above the recommended maximum duty will cause premature failure due to the build up of heat damaging the components.

Performance data was determined under the following conditions:

- 1) Unit in a temperature stable condition.
- 2) Test conditions: Inlet air density at 0.075lbs. per cubic foot. (20°C(68°F), 29.92 in. Hg(14.7PSIA)).
- 3) Normal performance variations on the resistance curve within +/- 10% of supplied data can be expected.
- 4) Specifications subject to change without notice.
- 5) All performance at 60Hz operation.

Oilless Regenerative Blowers, Motor Mounted to 88 cfm



REGENAIR® R4 Series

VACUUM

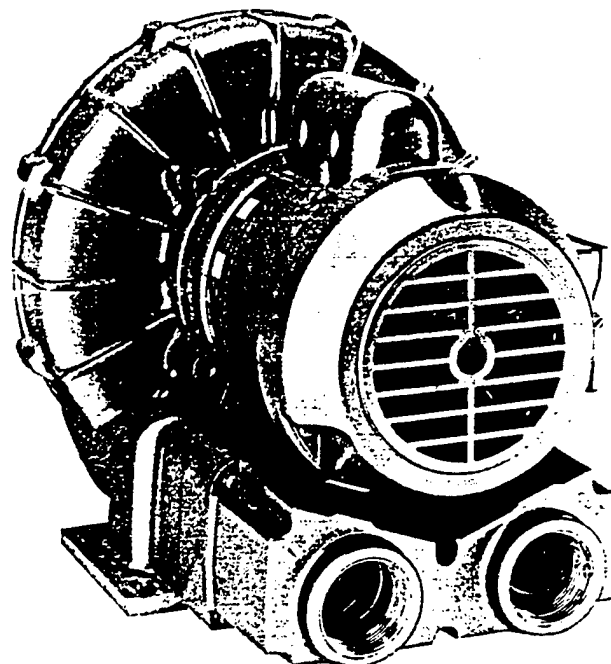

MODEL R4110-2
48" H₂O MAX. VAC., 88 CFM OPEN FLOW

PRODUCT FEATURES

- Oilless operation
- TEFC motor mounted
- Can be mounted in any plane
- Rugged construction/low maintenance
- Can be operated with no air flow through unit
- Class B insulation on motors
- Automatic restart thermal protection on single phase motors

COMMON MOTOR OPTIONS

- 115/208-230V, 60 Hz; 110/220-240V, 50 Hz, single phase
- 208-230/460V, 60 Hz; 190-220/380-415V, 50 Hz, three phase
- 575V, 60 Hz, three phase

RECOMMENDED ACCESSORIES

- Vacuum gauge AJ497
- Filter AJ151D
- Muffler AJ121D
- Relief valve AG258
- Nema motor starter (reference Blower Catalog accessory section or consult your Gast representative)

Various brand name motors are used on any model at the discretion of Gast Mfg. Corp.

Product Dimensions Metric (mm) U.S. Imperial (inches)

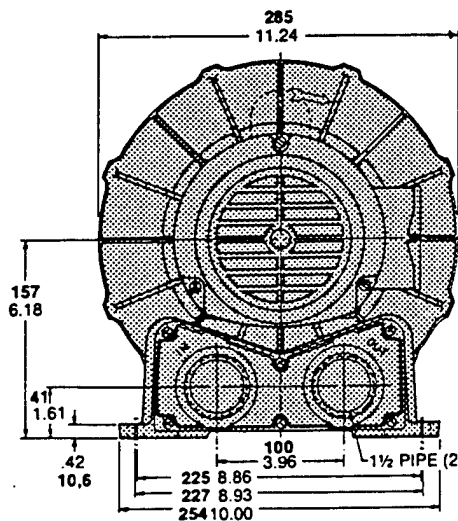
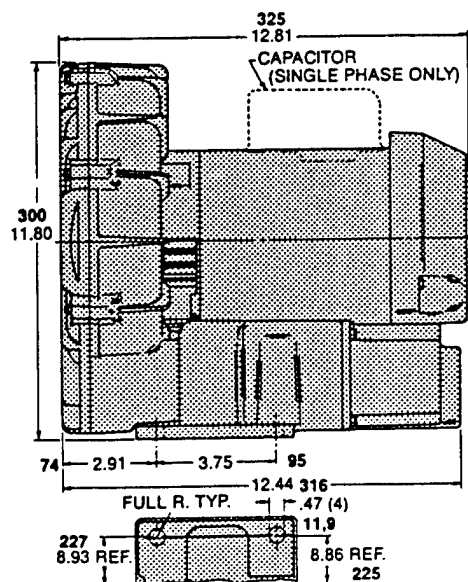

Important Notice:

Pictorial and dimensional data is subject to change without notice.

Product Specifications

Model Number	Motor Specs	Full Load Amps	HP	RPM	Max Vac		Max Flow		Net Wt.	
					"H ₂ O	mbar	cfm	m ³ h	lbs.	kg
R4110-2	110/220-240-50-1	9.0/4.5-5.7	0.6	2850	34	85	72	122	41	18,6
	115/208-230-60-1	9.8/5.2-4.9	1.0	3450	48	120	88	150		
R4310A-2	190-220/380-415-50-3	2.6-3.3/1.3-1.4	0.6	2850	34	85	72	122	41	18,6
	208-230/460-60-3	3.4-3.2/1.6	1.0	3450	48	120	88	150		

Product Performance (Metric U.S. Imperial)

Black line on curve is for 60 cycle performance.
Blue line on curve is for 50 cycle performance.

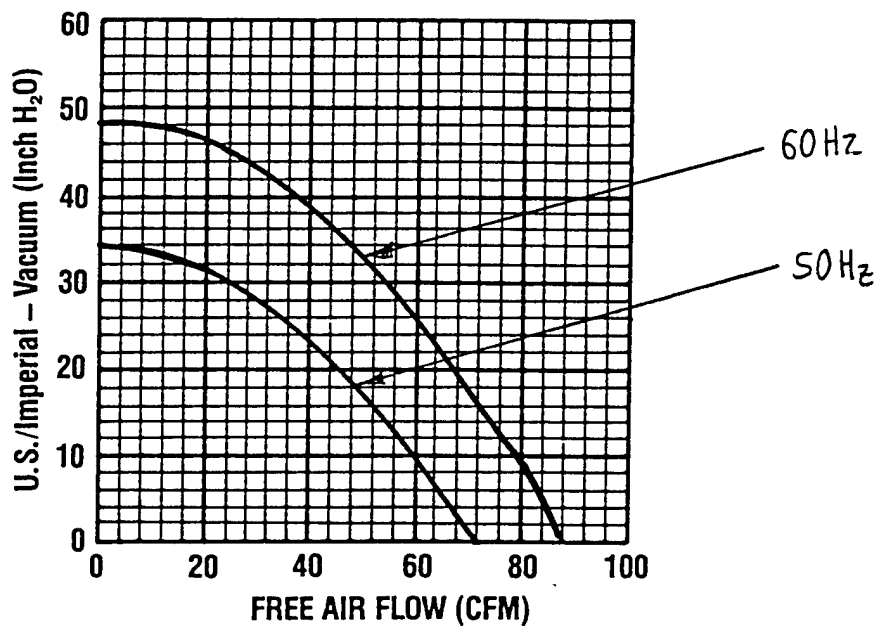
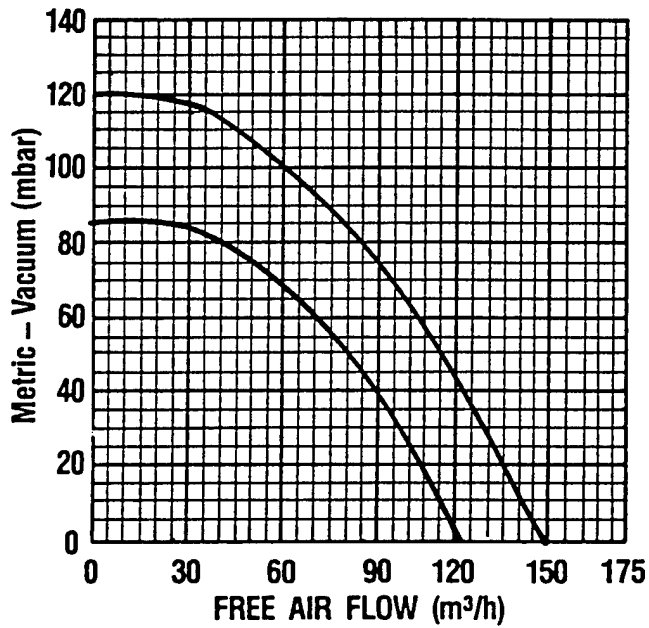

Oilless Regenerative Blowers, Motor Mounted to 145 cfm



REGENAIR® R5 Series

VACUUM

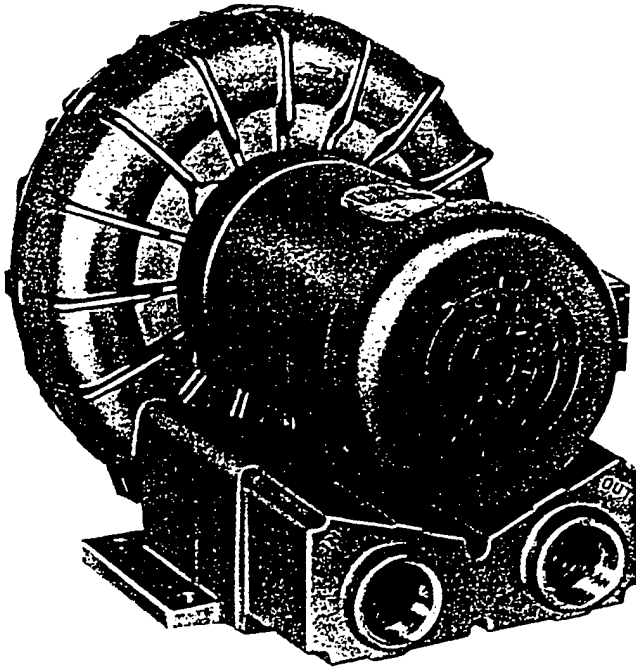

MODEL R5325A-2
60" H₂O MAX. VAC., 145 CFM OPEN FLOW

PRODUCT FEATURES

- Oilless operation
- TEFC motor mounted
- Can be mounted in any plane
- Rugged construction/low maintenance
- Class B insulation on motors
- Automatic restart thermal protection on motors

COMMON MOTOR OPTIONS

- 115/208-230V, 60 Hz; 110/220-240V, 50 Hz, single phase
- 208-230/460V, 60 Hz; 190-220/380-415V, 50 Hz, three phase
- 575V, 60 Hz, three phase

RECOMMENDED ACCESSORIES

- Vacuum gauge AJ497
- In-line filter AJ151E
- Muffler AJ121D
- Relief valve AG258
- Nema starter (reference Blower Catalog accessory section or consult your Gast representative)

Various brand name motors are used on any model at the discretion of Gast Mfg. Corp.

Important Notice:

Pictorial and dimensional data is subject to change without notice.

Product Dimensions Metric (mm) U.S. Imperial (inches)

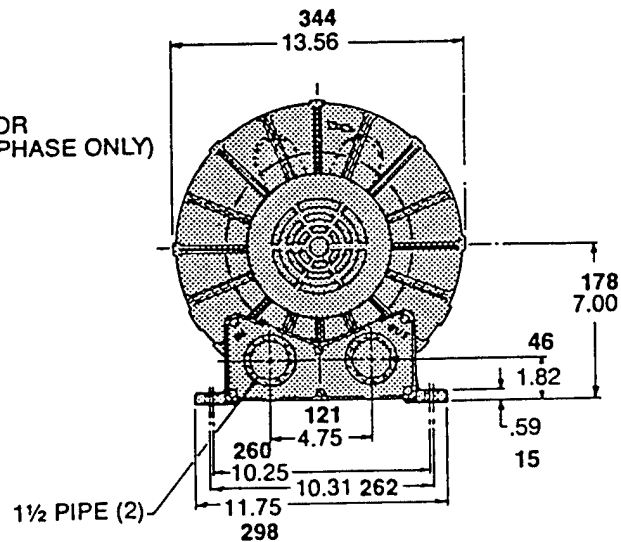
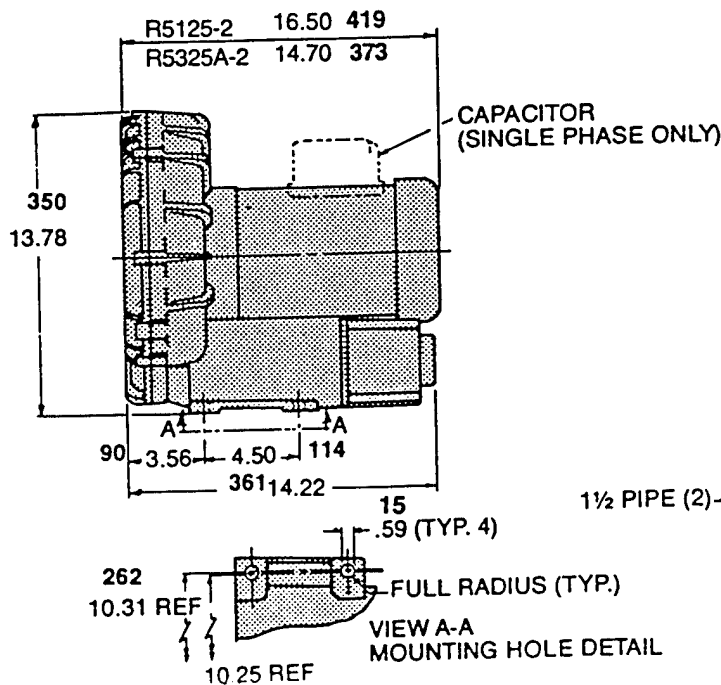

Product Specifications

Model Number	Motor Specs	Full Load Amps	HP	RPM	Max Vac		Max Flow		Net Wt.	
					"H ₂ O	mbar	cfm	m ³ h	lbs.	kg
R5325A-2	190-220/380-415-50-3	6.6-6.7/3.3-3.5	1.85	2850	47	117	120	204	65	29,5
	208-230/460-60-3	6.9/3.45	2.5	3450	60	149	145	246		
R5125-2	110/220-240-50-1	17.6/8.8-9.5	1.5	2850	47	117	120	204	76	34,5
	115/208-230-60-1	23.6/12.9-11.8	2.5	3450	60	149	145	246		

Product Performance (Metric U.S. Imperial) Black line on curve is for 60 cycle performance.
 Blue line on curve is for 50 cycle performance.

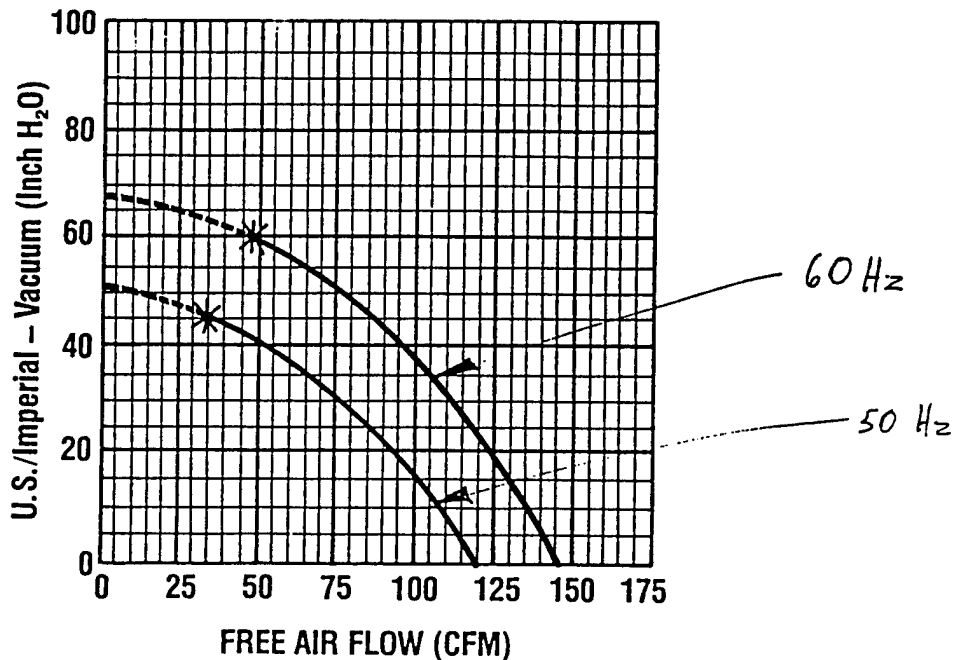
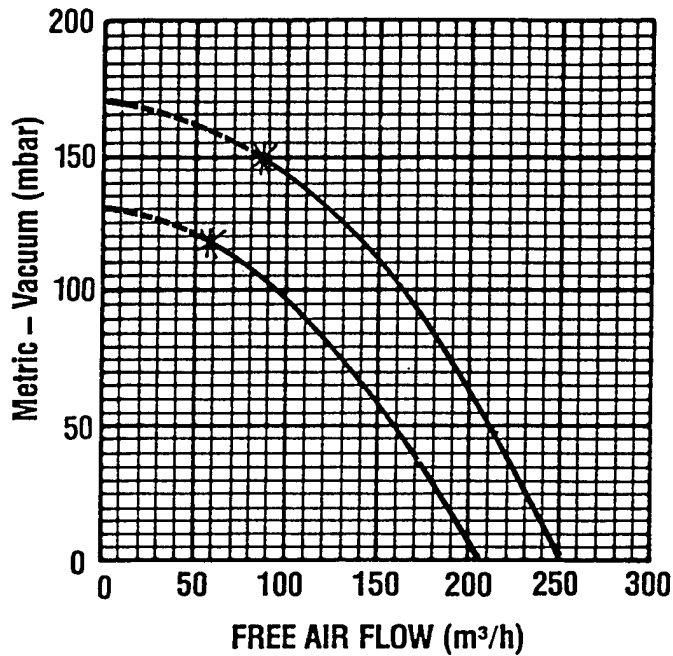

*Recommended maximum duty.
 - - - - Intermittent duty only.



70-6100
F2-205/8/92
Rev. E

Post Office Box 97
Benton Harbor, MI. 49023-0097
Ph: 616/926-6171
Fax: 616/925-8288

INSTALLATION AND OPERATING INSTRUCTIONS FOR GAST HAZARDOUS DUTY REGENAIR BLOWERS

This instruction applies to the following models ONLY: R3105N-50, R4110N-50, R4310P-50, R4P115N-50, R5125Q-50, R5325R-50, R6130Q-50, R6P155Q-50, R6350R-50, R6P355R-50 and R7100R-50.

Gast Authorized Service Facilities are Located in the locations listed below

Gast Manufacturing Corporation
505 Washington Avenue
Carlstadt, N. J. 07072
Ph: 201/933-8484
Fax: 201/933-5545

Gast Manufacturing Corporation
2550 Meadowbrook Road
Benton Harbor, MI. 49022
Ph: 616/926-6171
Fax: 616/925-8288

Brenner Fiedler & Associates
13824 Bentley Place
Cerritos, CA. 90701
Ph: 310/404-2721
Ph: 800/843-5558
Fax: 310/404-7975

Wainbee Limited
215 Brunswick Blvd.
Pointe Claire, Quebec
Canada H9R 4R7
Ph: 514/697-8810
Fax: 514/-697-3070

Wainbee Limited
5789 Coopers Ave.
Mississauga, Ontario
Canada L4Z 3S6
Ph: 416/243-1900
Fax: 416/243-2336

Japan Machinery
Central PO Box 1451
Toyko 100-91, Japan
Ph: 813 3573-5421
Fax: 813 3571-7896

Gast Manufacturing Co. Ltd.
Halifax Road, Cressex Estate
High Wycombe, Bucks HP12 3SN
England
Ph: 44 494 523571
Fax: 44 494 436588

OPERATING AND MAINTENANCE INSTRUCTIONS

SAFETY

This is the safety alert symbol. When you see this symbol personal injury is possible. The degree of injury is shown by the following signal words:

- ⚠ DANGER** Severe injury or death will occur if hazard is ignored.
- ⚠ WARNING** Severe injury or death can occur if hazard is ignored.
- ⚠ CAUTION** Minor injury or property damage can occur if hazard is ignored.

Review the following information carefully before operating.

GENERAL INFORMATION

This instruction applies to the following models ONLY: R3105N-50, R4110N-50, R4310P-50, R4P115N-50, R5125Q-50, R5325R-50, R6130Q-50, R6P155Q-50, R6350R-50, R6P355R-50 and R7100R-50. These blowers are intended for use in Soil Vapor Extraction Systems. The blowers are sealed at the factory for very low leakage. They are powered with a U.L. listed electric motor Class 1 Div. 1 Group D motors for Hazardous Duty locations. Ambient temperature for normal full load operation should not exceed 40° C (105° F). For higher ambient operation, contact the factory.

Gast Manufacturing Corporation may offer general application guidance: however, suitability of the particular blower and/or accessories is ultimately the responsibility of the user, not the manufacturer of the blower.

INSTALLATION

⚠ DANGER Models R5325R-50, R6130Q-50, R6350R-50, R5125Q-50, R6P155Q-50, R6P355R-50 AND R7100R-50 use Pilot Duty Thermal Overload Protection. Connecting this protection to the proper control circuitry is mandated by UL674 and NEC501. Failure to do so could result in a **EXPLOSION**. See pages 3 and 4 for recommended wiring schematic for these models.

⚠ WARNING Electric shock can result from bad wiring. A qualified person must install all wiring, conforming to all required safety codes. Grounding is necessary.

⚠ WARNING This blower is intended for use on soil vapor extraction equipment. Any other use must be approved in writing by Gast Manufacturing Corp. Install this blower in any mounting position. Do not block the flow of cooling air over the blower and motor.

PLUMBING - Use the threaded pipe ports for connection only. They will not support the plumbing. Be sure to use the same or larger size pipe to prevent air flow restriction and overheating of the blower. When installing fittings, be sure to use pipe thread sealant. This protects the threads in the blower housing and prevents leakage. Dirt and chips are often found in new plumbing. Do not allow them to enter the blower.

NOISE - Mount the unit on a solid surface that will not increase the sound. This will reduce noise and vibration. We suggest the use of shock mounts or vibration isolation material for mounting.

ROTATION - The Gast Regenair Blower should only rotate clockwise as viewed from the electric motor side. The casting has an arrow showing the correct direction. Confirm the proper rotation by checking air flow at the IN and OUT ports. If needed reverse rotation of three phase motors by changing the position of any two of the power line wires.

OPERATION

⚠ WARNING Solid or liquid material exiting the blower or piping can cause eye damage or skin cuts. Keep away from air stream.

⚠ WARNING - Gast Manufacturing Corporation will not knowingly specify, design or build any blower for installation in a hazardous, combustible or explosive location without a motor conforming to the proper NEMA or U. L. standards. Blowers with standard TEFC motors should never be utilized for soil vapor extraction applications or where local state and/or Federal codes specify the use of explosion-proof motors (as defined by the National Electric Code, Articles 100,500 c1990).

⚠ CAUTION Attach blower to solid surface before starting to prevent injury or damage from unit movement. Air containing solid particles or liquid must pass through a filter before entering the blower. Blowers must have filters, other accessories and all piping attached before starting. Any foreign material passing through the blower may cause internal damage to the blower.

⚠ CAUTION Outlet piping can burn skin. Guard or limit access. Mark "CAUTION Hot Surface. Can Cause Burns". Air temperature increases when passing through the blower. When run at duties above 50 in. H₂O, metal pipe may be required for hot exhaust air. The blower must not be operated above the limits for continuous duty. Only models R3105N-50, R4110N-50 and R4310P-50 can be operated continuously with no air flowing through the blower. Other units can only be run at the rating shown on the model number label. Do not Close off inlet (for vacuum) to reduce extra air flow. This will cause added heat and motor load. Blower exhaust air in excess of 230°F indicates operation in excess of rating which can cause the blower to fail.

ACCESSORIES ...Gast pressure gauge AJ496 and vacuum gauges AJ497 or AE134 show blower duty. The Gas pressure/vacuum relief valve, AG258, will limit the operating duty by admitting or relieving air. It also allows full flow through the blower when the relief valve closes.

SERVICING

⚠ WARNING To retain their sealed construction they should be serviced by Gast authorized service centers ONLY. These models are sealed at the factory for very low leakage.

⚠ WARNING Turn off electric power before removing blower from service. Be sure rotating parts have stopped. Electric shock or severe cuts can result. Inlet and exhaust filters attached to the blower may need cleaning or replacement of the elements. Failure to do so will result in more pressure drop, reduced air flow and hotter operation of the blower.

The outside of the unit requires cleaning of dust and dirt. The inside of the blower also may need cleaning to remove foreign material coating the impeller and housing. This should be done at a Gast Authorized Service Center. This buildup can cause vibration, failure of the motor to operate or reduced flow.

KEEP THIS INFORMATION WITH THIS BLOWER. REFER TO IT FOR SAFE INSTALLATION, OPERATION OR SERVICE.

MOTOR WIRING DIAGRAM FOR R4110N-50 & R3105N-50

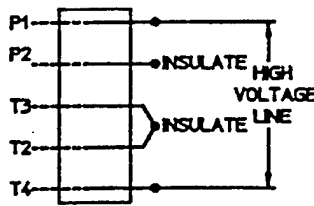
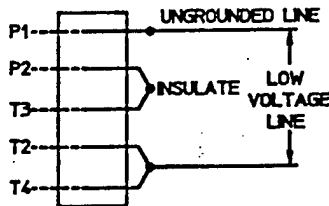

>># WARNING
THIS MOTOR IS THERMALLY PROTECTED AND WILL AUTOMATICALLY RESTART WHEN PROTECTOR RESETS. ALWAYS DISCONNECT POWER SUPPLY BEFORE SERVICING.

MOTORS WIRING DIAGRAM FOR R4310P-50

TO REVERSE ROTATION, INTERCHANGE THE EXTERNAL CONNECTIONS TO ANY TWO LEADS.

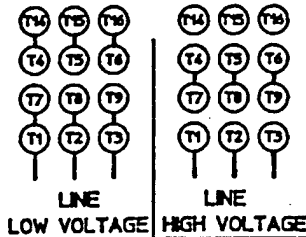

>># WARNING
THIS MOTOR IS THERMALLY PROTECTED AND WILL AUTOMATICALLY RESTART WHEN PROTECTOR RESETS. ALWAYS DISCONNECT POWER SUPPLY BEFORE SERVICING.

MOTORS WIRING DIAGRAM FOR R5325R-50, R6350R-50, R6P355R-50, & R7100R-50

TO REVERSE ROTATION, INTERCHANGE THE EXTERNAL CONNECTIONS TO ANY TWO LEADS.

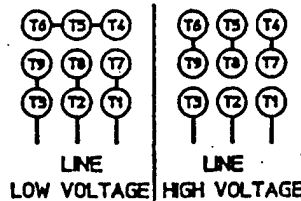
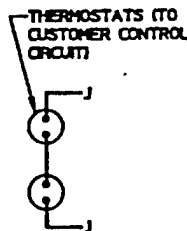

MOTOR WIRING DIAGRAM FOR R5125Q-50 & R4P115N-50

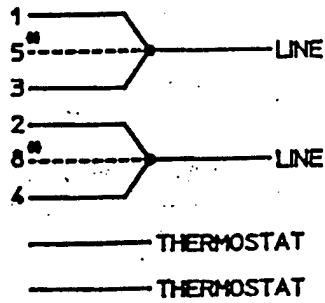

LOW VOLTAGE

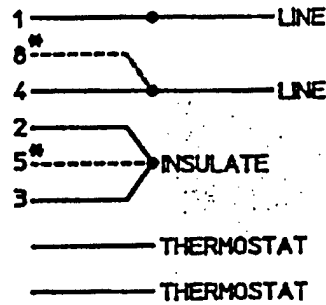

HIGH VOLTAGE

• R5125Q-50 BLOWERS PRODUCED AFTER SEPTEMBER 1992 (SER. NO. 0992) DO NOT HAVE MOTOR LEADS 5 & 8.

MOTOR WIRING DIAGRAM FOR R6130Q-50 & R6P155Q-50

CONNECT THERMOSTAT TO MOTOR PROTECTION CIRCUIT

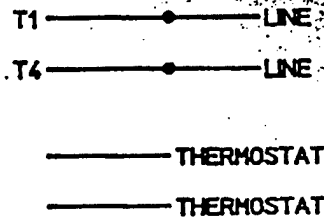

CONNECTION FOR THERMOSTAT MOTOR PROTECTION

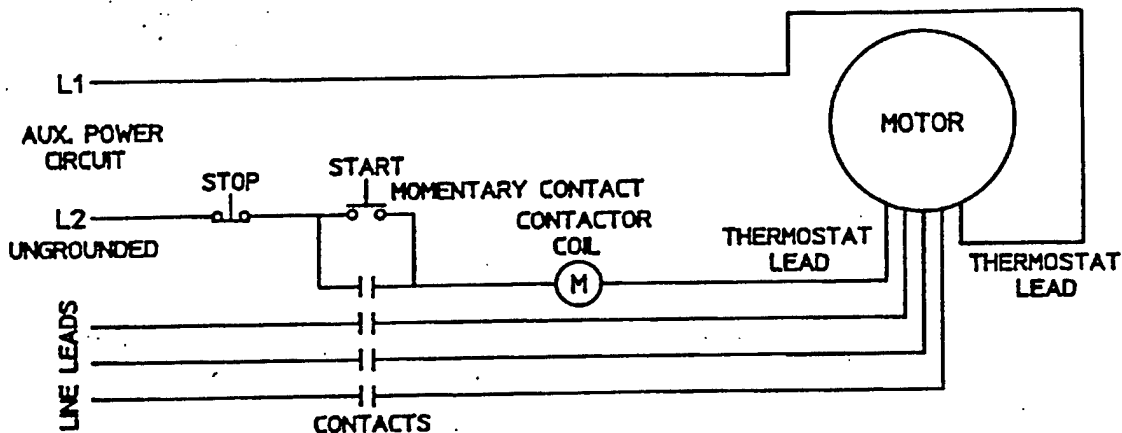

THERMOSTATS TO BE CONNECTED IN SERIES WITH CONTROL AS SHOWN. MOTOR FURNISHED WITH AUTOMATIC THERMOSTATS RATED A.C. 115-600V. 720VA

Relief Valve

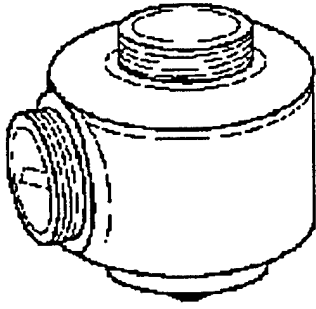

By setting a relief valve at a given pressure/vacuum, you can ensure excessive duties will not harm the blower or products in your application.

AG258	Relief valve	1½-inch NPT adjustable 30-200 inches H ₂ O, vacuum or pressure, 200 CFM max
AG258F	Relief valve	2½-inch NPT adjustable 30-200 inches H ₂ O, vacuum or pressure, 550 CFM max

[Print Form](#)

[Click Here for Catalog](#)

Gast Manufacturing Corp.
P.O. Box 97
Benton Harbor, MI 49023-0097
(616) 926-6171

Warranty

REGARDLESS OF CAUSE, if a product you buy from this brochure does not work right, Gast will repair or replace it once, at no charge, for up to one year from the date of shipment from the factory. In the course of repair or replacement, Gast may send you written recommendations on how to prevent a problem from happening again. Gast reserves the right to withdraw this warranty if you do not follow these recommendations. Customer is responsible for freight charges both to and from Gast in all cases. This warranty does not apply to electric motors, electrical controls, and gasoline engines, which Gast obtains from other manufacturers. A motor or engine carries only the warranty of the company that makes it.

THIS WARRANTY IS EXCLUSIVE AND IS IN LIEU OF ALL OTHER WARRANTIES, WHETHER WRITTEN, ORAL, OR IMPLIED, INCLUDING THE WARRANTY OF MERCHANTABILITY AND OF FITNESS FOR ANY PARTICULAR PURPOSE. GAST'S LIABILITY IS IN ALL CASES LIMITED TO THE REPLACEMENT PRICE OF ITS PRODUCT. GAST SHALL NOT BE LIABLE FOR ANY OTHER DAMAGES, WHETHER CONSEQUENTIAL, INDIRECT, OR INCIDENTAL, ARISING FROM THE SALE OR USE OF ITS PRODUCTS.

Gast's sales personnel may modify this warranty, but only by signing a specific, written description of any modifications.

Disclaimer

The information presented in this electronic catalog is based on technical data and test results of nominal units. It is believed to be accurate and is offered as an aid in the selection of Gast products. It is the user's responsibility to determine suitability of the product for his intended use and the user assumes all risk and liability whatsoever in connection therewith.



LOW PRESSURE GAUGES

Types 611.10 & 612.20

WIKI INSTRUMENT CORPORATION
 1000 Wiegand Boulevard
 Lawrenceville, Georgia 30243-5868
 (404) 513-8200 1-800-645-0608
 FAX: (404) 513-8203

PRICE LIST

Type 611.10 2 1/2" (63mm)
 Type 612.20 4" (100mm)

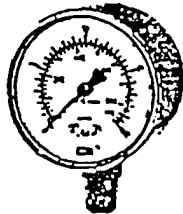

Standard Features

- Case: Black painted steel (611.10)
 Stainless steel (612.20)
- Bayonet Ring: None (2 1/2")
 Stainless steel (4")
- Wetted Parts: Copper alloy
- Window: Acrylic (2 1/2")
 Instrument glass (4")
- Dial: White aluminum
- Pointer: Black aluminum
- Accuracy: ± 1.5% of span

Brass movement with highly polished bearing surfaces

Recalibration screw on dial

Special Order Options

50 pcs. minimum order quantity per line item required (611.10)
 25 pcs. minimum order quantity per line item required (612.20)

Custom Dials - Special scales and dial markings are available. Standard list prices apply. Add any applicable artwork/set-up charges. Refer to "Custom Dial Artwork Charges" (price page PL95-32).

Special Connections - No additional charge for standard NPT or metric threads. Contact factory for other special threads.

Gauge Accessories - Additional accessories may be available. Refer to "Pressure Gauge Accessories" (price page PL95-30).

Additional Options Available -

- Nickel or chrome plated connection
- Lower back mount (Type 612.20 only)
- Rear flange
- U-clamp
- Safety glass window
- Stainless steel wetted parts 2 1/2" (631.10)
- Stainless steel wetted parts 4" (632.50)
- (refer to price page PL95-21 for prices)
- Cleaned for oxygen service
- Stainless steel case and ring
- Red drag pointer

- Items with part numbers are available from stock (subject to prior sale).
- Please use applicable part numbers when ordering.
- Items shown without part numbers are available on special order at no additional charge. Above listed minimum order quantities per line item required. Contact factory for current lead times.

Prices subject to change without notice.
 This price list supersedes price list dated 01/01/95.
 Effective 05/01/95 or
 Price Page PL95-20

Type	611.10		612.20	
Size	2 1/2"		4"	
Connection	LM	CBM	LM	
Conn. Size	1/4" NPT			
Data Sheet	APM 06.01		APM 06.02	
List Price	\$43.25	\$47.55	\$139.15	
Vacuum Range (dual scale)				
	inch water	mm water		
	0-30	0-760	9852344	9851352 9747724
	0-60	0-1500	9748321	9748339
	0-100	0-2500	9747473	9747465
Pressure Ranges (dual scale)				
	inch water	mm water		
	0-15	0-380	9851682	9851860 9747732
	0-30	0-760	9851690	9855785 9747740
	0-60	0-1500	9851704	9803432 9747758
	0-100	0-2500	9851810	9851879 9747766
	0-200	0-5000	9851828	9851887 9747775
	oz/ sq. in.	mm water		
	0-10	0-440	9851771	
	0-15	0-660	9851780	
	0-20	0-880	9851798	
	0-30	0-1320	9851747	9851917
	0-35	0-1540	9851801	9857273
	0-60	0-2640	9851755	9803548
	oz/ sq. in.	in. water		
	0-20	0-34	9851720	9857281
	0-32	0-55	9851739	9855793
Pressure Ranges (single scale)				
	psi			
	3	9851925	9851836	9747783
	5	9851933	9851844	9747791
Accessories (installed)				
<i>Accessory prices do not apply to orders of 50 pcs or more per line item (25 pcs. for type 612.20). Contact factory for quote.</i>				
FF, chrome plated brass	\$27.55	\$21.55	N/A	
	1327085	1327087		
FF, black painted steel	\$21.30	\$24.55	N/A	
	1327089	1327091		
FF, stainless steel	--	--	\$23.65	
			1327081	
Restrictor, brass	\$.90			
	1326943			

ABBREVIATIONS
 LM - Lower Mount
 CBM - Center Back Mount
 FF - Front Flange
 N/A - Not Available

In keeping with and for purposes of product improvement, Wika reserves the right to make design changes without prior notice.

Prices: FOB Lawrenceville, GA
 Terms: 30 days net
 (subject to credit approval)

APPENDIX B

DATA COLLECTION SHEETS

