

# LOAN DOCUMENT

PHOTOGRAPH THIS SHEET

①

INVENTORY

DTIC ACCESSION NUMBER

LEVEL

Work Implementation Plan Demonstration...

DOCUMENT IDENTIFICATION

5ep 98

**DISTRIBUTION STATEMENT A**  
Approved for Public Release  
Distribution Unlimited

DISTRIBUTION STATEMENT

ACCESSION CODE	
NTIS	GRAM
DTIC	TRAC
UNANNOUNCED	
JUSTIFICATION	
BY	
DISTRIBUTION/	
AVAILABILITY CODES	
DISTRIBUTION	AVAILABILITY AND/OR SPECIAL
A-1	

DISTRIBUTION STAMP

DATE ACCESSIONED

DATE ACCESSIONED

DATE RETURNED

DATE RETURNED

REGISTERED OR CERTIFIED NUMBER

REGISTERED OR CERTIFIED NUMBER

20001208 126

DATE RECEIVED IN DTIC

PHOTOGRAPH THIS SHEET AND RETURN TO DTIC-FDAC

H  
A  
N  
D  
L  
E  
  
W  
I  
T  
H  
  
C  
A  
R  
E

DRAFT FINAL

# WORK IMPLEMENTATION PLAN

Demonstration of:  
Microwave Regenerated  
Granular Activated Carbon

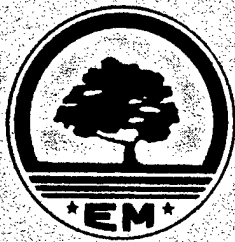

McClellan Air Force Base  
Sacramento, California

Contract: F04699-97-D-0023  
Delivery Order: 3004

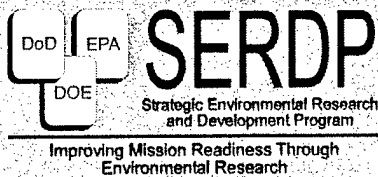

September 1998

Submitted by:

**METRIC**

The Metcalf & Eddy METRIC Team  
3841 N. Freeway Blvd., Suite 130, Sacramento, CA 95834

AQM01-03-0424

**DEFENSE TECHNICAL INFORMATION CENTER  
REQUEST FOR SCIENTIFIC AND TECHNICAL REPORTS**

Title AFCEE Collection

<b>1. Report Availability</b> (Please check one box)	<b>2a. Number of Copies Forwarded</b>	<b>2b. Forwarding Date</b>
<input checked="" type="checkbox"/> This report is available. Complete sections 2a - 2f. <input type="checkbox"/> This report is not available. Complete section 3.	<u>1 each</u>	<u>July/2000</u>

**2c. Distribution Statement** (Please check ONE box)

DoD Directive 5230.24, "Distribution Statements on Technical Documents," 18 Mar 87, contains seven distribution statements, as described briefly below. Technical documents MUST be assigned a distribution statement.

DISTRIBUTION STATEMENT A: Approved for public release. Distribution is unlimited.

DISTRIBUTION STATEMENT B: Distribution authorized to U.S. Government Agencies only.

DISTRIBUTION STATEMENT C: Distribution authorized to U.S. Government Agencies and their contractors.

DISTRIBUTION STATEMENT D: Distribution authorized to U.S. Department of Defense (DoD) and U.S. DoD contractors only.

DISTRIBUTION STATEMENT E: Distribution authorized to U.S. Department of Defense (DoD) components only.

DISTRIBUTION STATEMENT F: Further dissemination only as directed by the controlling DoD office indicated below or by higher authority.

DISTRIBUTION STATEMENT X: Distribution authorized to U.S. Government agencies and private individuals or enterprises eligible to obtain export-controlled technical data in accordance with DoD Directive 5230.25, Withholding of Unclassified Technical Data from Public Disclosure, 6 Nov 84.

**2d. Reason For the Above Distribution Statement** (in accordance with DoD Directive 5230.24)

<b>2e. Controlling Office</b> <u>HQ AFCEE</u>	<b>2f. Date of Distribution Statement Determination</b> <u>15 Nov 2000</u>
--	---

**3. This report is NOT forwarded for the following reasons.** (Please check appropriate box)

It was previously forwarded to DTIC on ..... (date) and the AD number is .....

It will be published at a later date. Enter approximate date if known. ....

In accordance with the provisions of DoD Directive 3200.12, the requested document is not supplied because:  
.....  
.....

<b>Print or Type Name</b> <u>Laura Peña</u>	<b>Signature</b> <u>Laura Peña</u>
<b>Telephone</b> <u>210-536-1431</u>	<b>AQ Number</b> (For DTIC Use Only) <u>M01-03-0424</u>

# **WORK IMPLEMENTATION PLAN**

## **DEMONSTRATION OF MICROWAVE REGENERATED GRANULAR ACTIVATED CARBON**

McClellan Air Force Base  
Sacramento, California

This document was prepared by Metcalf & Eddy, Inc. (M&E) at the direction of McClellan Air Force Base (McClellan AFB) for the sole use of McClellan AFB and the regulatory agencies overseeing the McClellan AFB Installation Restoration Program, the only intended beneficiaries of this work. No other party should rely on the information contained herein without the prior written consent of McClellan AFB. This report and the interpretations, conclusions, and recommendations contained within are based in part on information presented in other documents provided by the McClellan AFB Administration Record.

**RESPONSE TO COMMENTS**  
**DRAFT FINAL WORK IMPLEMENTATION PLAN**  
**DEMONSTRATION OF**  
**MICROWAVE REGENERATED GRANULAR ACTIVATED CARBON**

<b>WIP REFERENCE:</b>	<b>MCCLELLAN AFB COMMENT:</b> (Tim Chapman - TRW)	<b>M&amp;E RESPONSE:</b>
<p><b>1.4 Site Selection:</b></p>	<p>The results of this evaluation and the logic used to evaluate and determine the selection should be better documented. The evaluation presented does not provide sufficient details on why this site was selected. Also, all of the sites evaluated would have "adequate" contaminant mass to achieve the stated saturation. I believe site selection was driven as much by logistical concerns as it was site-specific contaminant profiles.</p>	<p>M&amp;E has modified section 1.4. Although each of the mentioned sites have similar contaminant profiles, OU D Site S was selected based on the layout of the site and the logistical concerns of equipment installation.</p>
<p><b>2.1 Site Location and History:</b></p>	<p>The description of the SVE removal and treatment system in not complete or wholly accurate. There is no need to describe the cap over OU D; however, the description of the treatment system should indicate the number of SVE wells installed and the number of disposal sites at OU D being remediated by SVE. Refer to URSG quarterly O&amp;M reports or RAWPs for more complete information. The SVE system at IC 19 is treated by the Site S treatment system and that clarification needs to be made. Overall, this section needs to be expanded and clarified to succinctly describe the SVE removal and treatment operations.</p>	<p>M&amp;E has modified this section to include more detail with regard to the number of SVE wells actively being remediated. The description of the cap has been removed and the number of disposal sites has been added.</p>
<p><b>2.4 Contaminant Distribution (Table 1):</b></p>	<p>The contaminant distribution of the SVE treatment system is dependent on the well configuration being operated. It is not appropriate to provide a "single" event influent contaminant distribution. At a minimum, an average of the last quarter's concentrations should be used. Also, the treatment system effluent and DREs are not appropriate and should be removed. This section should describe the general make-up of the off-gas and any appropriate trends in mass reduction over time (<i>i.e.</i>, it should provide the expected off-gas conditions that the demonstration system will treat).</p>	<p>M&amp;E has averaged effluent concentrations collected from January to March 1998 to calculate influent mass emission rates. DREs and effluent emission rates have been removed from Table 1. M&amp;E has also included text about the make-up of the off gas and overall trends in mass reduction.</p>

<b>WIP REFERENCE:</b>	<b>MCCLELLAN AFB COMMENT:</b> (Tim Chapman –TRW)	<b>M&amp;E RESPONSE:</b>
<p><b>3.1.3 Microwave GAC Regenerator:</b></p>	<p>More detail is needed on the mechanism by which the VOCs are desorbed from the GAC by microwaves. In that, what causes the desorption – direct excitation at the adsorption site, microwave heating of the GAC, etc.</p>	<p>Additional information has been included about the removal mechanisms (i.e., dipole rotation and ionic conduction) by which VOCs are desorbed from the GAC in the microwave unit.</p>
<p><b>3.1.4 Microwave Oxidation Catalyst Reactor</b></p>	<p>Is the silicone carbide the oxidizing catalyst in this reaction? The sentence should be clarified.</p>	<p>Section 3.1.3 has been modified to include clarifications about the oxidizing catalyst.</p>
<p><b>3.3.2 Limitations:</b></p>	<p>The last sentence should be deleted. It is not appropriate to the description of the limitations of the technology. Some standard limitations would seem to be appropriate to this technology, such as low-affinity compounds may not be adsorbed effectively by the system, etc.</p>	<p>M&amp;E has incorporated potential system limitations during system operation.</p>
<p><b>4.1 General Overview:</b></p>	<p>State that M&amp;E will evaluate the “cost and performance” of the system.</p>	<p>M&amp;E has incorporated the suggested revision accordingly.</p>
<p><b>4.2 Description of Technology Process:</b></p>	<p>In paragraph 2, what is the size of the adsorber vessel, i.e., is it a 600-pound vessel or will 600-lb total be used in the system?</p>	<p>M&amp;E has clarified this sentence and has added specifications of the adsorber vessel.</p>
<p><b>4.4.4 Verify That System Performance Meets BACT:</b></p>	<p>While the mass balance presented in this section should be conducted, BACT will be verified by performing a paired T-test on ROCs in the air stream.</p>	<p>M&amp;E has modified the text to include verification of BACT by performing a paired T-test on ROCs in the air stream.</p>
<p><b>4.6 Data Analysis and Interpretation:</b></p>	<p>The statistics involved in determining BACT are more involved than determining “mean DREs at the 95% confidence interval.” If this is being used as a colloquialism, then reference Section 8 for details.</p>	<p>A statistical analysis will be performed to verify that the DREs meet BACT requirements.</p>
<p><b>5.2 System Installation:</b></p>	<p>The drawings will also be used by M&amp;E to construct the system. Utility requirements need to be stated in this section. Any special equipment (e.g., forklifts, cranes, etc.) must also be listed. Any installations or activities that are required to be performed by the base should be clearly stated. Specifics on the “shed” must also be provided including design specifications or codes that the structure will be built to. Materials and construction methods should</p>	<p>No special equipment will be required during equipment installation activities. The treatment shed specifications have been included as Appendix C. The electrical specifications for automatic shutdown have also been included in this section.</p>

<b>WIP REFERENCE:</b>	<b>MCCLELLAN AFB COMMENT:</b> (Tim Chapman - TRW)	<b>M&amp;E RESPONSE:</b>
<p><b>5.3.1 Startup Phase:</b></p>	<p>be included. Specifics on how the automatic shutdown will be wired should be included in the text.</p>	<p>M&amp;E has included a set of initial operating parameters for airflow rate, temperature, and pressure during operation of the test. These operating parameters are not anticipated to change significantly during the demonstration.</p>
<p><b>5.3.2 Test Phase:</b></p>	<p>The SAP table shows that flow, temperature, and pressures will be monitored continuously, yet the text indicates daily monitoring by the field technician. Section 7.1 states a data acquisition system will measure these. Which method will be used?</p>	<p>M&amp;E has incorporated the suggested changes. The flow, temperature, and pressure will be monitored continuously and recorded by the data acquisition system.</p>
<p><b>5.4 Material Storage:</b></p>	<p>The wt% of the NaOH solution or description of the solid phase stored needs to be included along with the amount of NaOH that will be stored on-site.</p>	<p>M&amp;E has included the suggested comments pertaining to NaOH concentration and storage.</p>
<p><b>Section 5:</b></p>	<p>This section needs to include a section on demobilization of the site, site restoration, and the requirement that restoration will be approved by the Field Team.</p>	<p>M&amp;E has expanded this section to include activities associated with site demobilization procedures.</p>
<p><b>6.2 Regulatory Compliance:</b></p>	<p>This section is meant to describe which and how regulations apply to and effect the application of the technology. Therefore, the section should be rewritten with this in mind. Also, McClellan AFB does not have a permit to operate, nor is one required, for CERCLA remediation systems.</p>	<p>This section has been modified to describe how the regulations apply to and effect the application of this technology.</p>
<p><b>7.1 System Startup and Optimization Sampling:</b></p>	<p>The manufacturer, specifications, and ranges of the flow meter, thermocouple, and pressure sensor need to be provided. The same is true for all field instrumentation that will be used in the performance data acquisition. For each sampling event, the names of the locations from Section 7.6 should be identified not just "lumped" together as "3 vapor ports." The type of inert tubing (Teflon is used later) should be specified and the approved sampling SOP referenced. The EPA method referenced is not appropriate for process</p>	<p>M&amp;E has modified this section to include:</p> <ul style="list-style-type: none"> <li>◆ Manufacturer and specifications of the flow meter, thermocouple, pressure sensor, and field instrumentation (included in Table 7-2).</li> <li>◆ Labeling of individual sample locations.</li> <li>◆ SOPs for field activities associated with vapor</li> </ul>

<b>WIP REFERENCE:</b>	<b>MCCLELLAN AFB COMMENT:</b> (Tim Chapman – TRW)	<b>M&amp;E RESPONSE:</b>
	<p>gas measurements. The approved McClellan SOP should be referenced and used. Also, the text description for the VOC and NMOC measurements could be shortened to say that samples will be taken IAW the SOP or it should be corrected to reference the specific methods. A more integrated method of determining VOC and NMOC should be considered (using more than 1-minute for the sample would provide better averaging). Time periods of up to 2-4 hours are much more representative of what conditions actually exist in the system over time. It does not seem necessary to take a field duplicate during startup phase and M&amp;E should consider using this duplicate during the operational period.</p>	<ul style="list-style-type: none"> <li>◆ monitoring and sampling activities.</li> <li>◆ Type of inert tubing</li> <li>◆ Removal of EPA method reference</li> <li>◆ More brief description of VOC and NMOC measurement</li> <li>◆ Sample collection time will be extended as much as possible (to allow for better averaging).</li> <li>◆ Field duplicate deleted from first week of operation.</li> </ul>
<p><b>7.2 Test Phase:</b></p>	<p>The SOPs and sampling frequency table should be included in this section. Also, this section should describe how influent and effluent samples will be taken (sequentially, simultaneously, etc.). These methods need to avoid prolonged delays in taking the paired influent/effluent samples for a particular analysis (VOCs, SVOCs, and NMOCs).</p>	<p>M&amp;E has included the necessary SOPs for vapor sampling in this section. Influent and effluent samples will be collected simultaneously.</p>
<p><b>7.4 Post-Test Sampling:</b></p>	<p>The sampling procedures for liquid and GAC should be referenced (approved McClellan SOPs if available) or included in this document.</p>	<p>M&amp;E has included text for liquid and GAC sampling procedures.</p>
<p><b>7.5 Sample Custody and Documentation:</b></p>	<p>More detailed information is required including, but not limited to, sample identification, storage on site, COC procedures, etc.</p>	<p>M&amp;E has expanded the text in this section to include specific COC procedures. Specific sample labeling procedures are presented in section 7.6.</p>
<p><b>8.2 Measurements:</b></p>	<p>The basis for considering the flow rate, temperature, and pressure data as definitive needs to be provided.</p>	<p>These meters will be factory calibrated by the manufacturer. Measured flow rates will be compared using available pump curve data (pressure vs. flow) provided by the blower manufacturer.</p>

<b>WIP REFERENCE:</b>	<b>MCCLELLAN AFB COMMENT:</b> (Tim Chapman – TRW)	<b>M&amp;E RESPONSE:</b>
<p><b>8.4 Quality Assurance Objectives:</b></p>	<p>While DQOs are referenced, none are included. DQOs should be developed for each of the performance objectives or the DQO process that will be followed should be included.</p>	<p>DQOs have not been established for this project. How M&amp;E proposes to assess the qualitative data is specified in Section 4.6. The laboratory quality control acceptance criteria is shown on Table 8-1.</p>
<p><b>8.6 Equipment Calibration and Preventative Maintenance:</b></p>	<p>The equipment calibration procedures and methods should be included or referenced as appropriate for field instrumentation.</p>	<p>M&amp;E has included equipment calibration procedures and methods in this section.</p>
<p><b>8.7 Sample Handling:</b></p>	<p>This section should be expanded to give references to SOPs/QAPPs and a basic description of sample handling or specific procedures included.</p>	<p>M&amp;E has expanded the section including a basic description of sample handling procedures along with referenced SOPs.</p>
<p><b>8.10.2 System Audits:</b></p>	<p>The minimum number of audits should be included (e.g., one, two, etc.).</p>	<p>M&amp;E has modified the text to include the frequency of performance and system audits.</p>
<p><b>Figure 3:</b></p>	<p>The use of "Site S Air Source" is not appropriate. Suggest changing to "SVE vapor." The air cooler shown is not referenced anywhere in the text. The specifications, operation, etc. of this unit should be captured in the text. Isolation valves should be shown at the interface to the SVE system. Also, a backflow preventer valve should be included in the system.</p>	<p>M&amp;E has included the specifications, operation, etc. of the air cooler in Section 3.1.2. In addition, backflow preventer valves have been incorporated in the system.</p>
<p><b>Figure 4:</b></p>	<p>The names of the specific ports defined in Section 7.6 should be used on this figure.</p>	<p>M&amp;E has included these changes on the P&amp;ID figure.</p>
<p><b>Table 3:</b></p>	<p>This table lists incorrect/inappropriate holding times and preservation for vapor samples. The current analytical method identifiers should be used (e.g., TO-14A). The correct preservation pH should be included for liquid samples.</p>	<p>Current analytical methods, proper holding times and preservation for vapor samples (as well as for pH) have been included.</p>
<p><b>Table 4:</b></p>	<p>The base-wide SVE RAWP or other approved SVE documents should be cited as appropriate for analytical objectives. This table does not provide DQOs.</p>	<p>Table 4 has been modified to include quality control acceptance criteria.</p>

<p><b>WIP REFERENCE:</b></p> <p>Appendix A Site Monitoring:</p>	<p><b>MCCLELLAN AFB COMMENT:</b> (Tim Chapman – TRW)</p> <p>This document does not contain a Site-Specific Spill Plan as required by the PWS.</p> <p>The HASP should include monitoring requirements for microwave radiation.</p>	<p><b>M&amp;E RESPONSE:</b></p> <p>M&amp;E has included a Site-Specific Spill Plan in Appendix A.</p> <p>M&amp;E has included monitoring requirements specifically for microwave radiation.</p>
---	---	---

COMMENT:	RWQCB COMMENTS: (Alex McDonald)	M&E COMMENTS:
1.	Change Ug/kg to micrograms-per-kilogram	M&E has made these changes.
2.	Delete "Metcalf & Eddy, Inc. (M&E) and replace with M&E as the abbreviation has been provided in line 2.	M&E has made these changes.
3.	Delete "and" after "Low"	M&E has made these changes.
4.	Change "entrance area" to "contaminated disposal pits"	M&E has made these changes.
5.	Include discussion on possible formation of HF potentially from freons.	M&E has included text about the formation of sodium fluoride (NaF).
6.	Be more precise than "near 100 percent". May want to utilize "at least 9X%"	M&E has modified this sentence to "at least 99%".
7.	Change "companion" to "comparison"	M&E has made these changes.
8.	In addition to demonstrating the expected useful life of the regenerated GAC for cost analysis, disposal cost of the spent GAC needs to be included.	M&E has made these changes.
9.	Include reference to SMAQMD requirements for desired BACT criteria of 95% DRE.	M&E has made these changes.
10.	Delete "test" after "characterization"	M&E has made these changes.
11.	Change "remediation" after "implemented" to "removal actions for soils under a base-wide Soil Vapor Extraction Engineering Evaluation/Cost Analysis and containment actions under a Base-wide Groundwater Interim Record of Decision."	M&E has made these changes.
12.	Change "drums" to "drum after "55-gallon"	M&E has made these changes.
13.	Prior to storing hazardous materials (sodium hydroxide), the contractor will coordinate with the McClellan AFB field team representative to fill out the appropriate paperwork	M&E has made these changes.

COMMENT:	RWQCB COMMENTS: (Alex McDonald)	M&E COMMENTS:
14.	for the AF pharmacy.	M&E has made these changes.
15.	Change "provide" to "provides" after "section"	M&E has included a brief discussion pertaining to the management of the air water separator.
16.	How will the contractor manage the fluids from the knock out pot? Include a discussion here.	M&E has made these changes.
17.	Delete "in the event of MR GAC system failure." The existing system will always treat the MR GAC effluent.	M&E has made these changes.
18.	Include text that discusses following the approved McClellan QAPP and include the methods from the QAPP in an appendix.	M&E has made these changes.
19.	Same as comment 17.	M&E has made these changes.
20.	The sampling method for collecting the scrubber effluent needs to be described (unless there is an approved method in the QAPP) and provided in an appendix.	M&E has made these changes.
21.	What test method will be used to test for HF as described in section 4.5?	HF will be tested using EPA Metho 26A.
22.	Add text of McClellan QAPP instead of United States Air Force (USAF) protocols.	M&E has made these changes.
23.	Change "a s" to "as" after "(such"	M&E has made these changes.
24.	Include text on using IRPIMS or IRPIMS like format for electronic data submittals.	M&E has made these changes.
25.	Change "outlines" to "outlined"	M&E has made these changes.
26.	Delete "a" after "verified by"	M&E has made these changes.
27.	Delete " , " after "results"	M&E has made these changes.
	Delete "se" after "sample"	M&E has made these changes.

COMMENT:	RWQCB COMMENTS: (Alex McDonald)	M&E COMMENTS:
28.	Change "land" to "and"	M&E has made these changes.
29.	Change "mush" to "must"	M&E has made these changes.
30.	Add "be" after "to"	M&E has made these changes.
31.	Change "They" to "The"	M&E has made these changes.
32.	Change "the" to "be" after "to"	M&E has made these changes.
33.	Put the figure of the schedule here.	M&E has made these changes.
34.	Change "(CRW)" to "(TRW)"	M&E has made these changes.
35.	Include information on sodium hydroxide as part of the chemical hazards that could be encountered at the site and provide information in the appropriate tables.	M&E has included information about sodium hydroxide in the HASP.
36.	Include information for physical hazardous to on hornets/yellow jackets, black widow spiders, and rattle snakes that could be present on site.	M&E has made these changes.
37.	Include a figure showing routes to the local hospital.	M&E has included a map to the local hospital.
38.	We would recommend some text to be added delineating the need to adsorb and desorb the contaminants from the extraction stream prior to treatment. In other words, why not just process the slipstream directly through the microwave treatment system?	The GAC is used as an adsorber to concentrate the VOC air stream. The concentrated air stream is then directed through the microwave treatment unit at 5 cubic feet per hour which is much more cost effective.
39.	Page 4-2, Section 4.4. In many of the SVE treatment systems there have been found to be concentrations of dioxins in the off-gas and scrubber blowdown, in addition to some catalyst carryover. No sampling is being proposed for these constituents. Justification for not sampling for those contaminants needs to be provided. Also, identification of the catalyst should be included in the document.	One sample from the microwave discharge during system startup will be analyzed for dioxins.

COMMENT:	RWQCB COMMENTS: (Alex McDonald)	M&E COMMENTS:
40.	Include the figures and tables in the appropriate sections of the WIP.	M&E has made these changes.
41.	Print text on both sides of the page to reduce volume.	M&E has made these changes.
42.	Include sections of the approved McClellan QAPP as an appendix and where no QAPP method exists, develop one and also include it in the appendix.	M&E has made these changes.

# TABLE OF CONTENTS

## WORK IMPLEMENTATION PLAN TECHNOLOGY DEMONSTRATION

### 1.0 INTRODUCTION AND BACKGROUND

1.1	Program Overview .....	1-1
1.2	Technology Need .....	1-1
1.3	Report Organization .....	1-2
1.4	Site Selection.....	1-3

### 2.0 SITE DESCRIPTION

2.1	Site Location and History.....	2-1
2.2	Geology .....	2-1
2.3	Hydrogeology.....	2-5
2.4	Contaminant Distribution.....	2-5

### 3.0 TECHNOLOGY DESCRIPTION

3.1	Principles of Technology.....	3-1
3.1.1	Technology Summary.....	3-1
3.1.2	GAC Moving-Bed Adsorber.....	3-3
3.1.3	Microwave GAC Regenerator .....	3-3
3.1.4	Microwave Oxidation Catalyst Reactor .....	3-3
3.1.5	Acid Gas Scrubber.....	3-4
3.2	Technology Applicability.....	3-4
3.3	Advantages and Limitations of Technology .....	3-4
3.3.1	Advantages.....	3-4
3.3.2	Limitations.....	3-5

### 4.0 OBJECTIVES

4.1	General Overview.....	4-1
4.2	Description of Technology Process.....	4-1
4.3	Statement of Demonstration's Objectives.....	4-2
4.4	Test Plan.....	4-2
4.4.1	Demonstrate System Performance Efficiency.....	4-2
4.4.2	Quantify Cost Data .....	4-3
4.4.3	Determine The Expected Useful Life of Regenerated GAC .....	4-3
4.4.4	Verify That System Performance Meets BACT.....	4-3

# TABLE OF CONTENTS (*Continued*)

4.5	Technology Parameters Evaluation.....	4-4
4.6	Data Analysis and Interpretation.....	4-4
<b>5.0</b>	<b>FIELD ACTIVITIES</b>	
5.1	Pre-Operational Characterization.....	5-1
5.2	System Installation.....	5-1
5.3	System Operation.....	5-4
5.3.1	Startup Phase.....	5-4
5.3.2	Test Phase.....	5-5
5.4	Material Storage.....	5-7
5.5	Residuals Management.....	5-7
5.5.1	Liquid Phase Product (Scrubber Solution).....	5-7
5.5.2	Regenerated GAC.....	5-8
5.5.3	Decontamination Rinseate.....	5-8
5.5.4	Demobilization and Site Restoration Procedures.....	5-8
<b>6.0</b>	<b>PERMITTING AND REGULATORY COMPLIANCE</b>	
6.1	Permitting.....	6-1
6.2	Regulatory Compliance.....	6-1
6.2.1	Compliance with Emission Reduction Credit Allocation.....	6-1
6.2.2	Dioxin/Furan Emissions.....	6-1
6.2.3	Health and Safety Requirements.....	6-2
<b>7.0</b>	<b>SAMPLING PLAN</b>	
7.1	System Startup and Optimization Sampling.....	7-1
7.2	Test Phase.....	7-3
7.3	Assessment of Undesirable Byproducts.....	7-4
7.4	Post-Test Sampling.....	7-5
7.5	Sample Custody and Documentation.....	7-5
7.6	Field Sample Identification.....	7-6
<b>8.0</b>	<b>QUALITY ASSURANCE PROJECT PLAN</b>	
8.1	Introduction and Objectives.....	8-1
8.2	Measurements.....	8-1
8.3	Key Personnel.....	8-1
8.3.1	Program Manager.....	8-3
8.3.2	Project Manager.....	8-3
8.3.3	Project Engineer.....	8-4
8.3.4	Technology Specialist.....	8-4
8.3.5	Field Test Manager.....	8-4

# TABLE OF CONTENTS (Continued)

8.3.6	Program Health and Safety Manager.....	8-4
8.3.7	M&E Data Validation Manager.....	8-5
8.3.8	Laboratory Manager .....	8-5
8.4	Quality Assurance Objectives .....	8-5
8.4.1	Precision .....	8-6
8.4.2	Accuracy .....	8-8
8.4.3	Completeness.....	8-8
8.4.4	Representativeness.....	8-9
8.4.5	Comparability .....	8-9
8.5	Analytical Methods .....	8-9
8.6	Equipment Calibration and Preventive Maintenance.....	8-10
8.7	Sample Handling.....	8-11
8.8	Data Reduction, Validation, and Reporting .....	8-11
8.8.1	Data Collection .....	8-11
8.8.2	Data Reduction .....	8-12
8.8.3	Laboratory Data Review.....	8-12
8.8.4	Evaluation of Data Using Control Charts.....	8-13
8.8.5	Laboratory Data Reporting.....	8-13
8.8.6	Data Validation.....	8-13
8.9	Internal Quality Control Checks.....	8-14
8.9.1	Trip Blanks .....	8-14
8.9.2	Field Duplicates.....	8-15
8.9.3	Equipment Blanks.....	8-15
8.10	Performance and System Audits .....	8-15
8.10.1	Performance Audits .....	8-15
8.10.2	System Audits.....	8-16
8.11	Corrective Action .....	8-16
8.11.1	Laboratory Activities.....	8-16
8.11.2	Field Activities.....	8-19

## 9.0 SCHEDULE

## 10.0 MANAGEMENT AND STAFFING

## 11.0 REFERENCES

Appendix A HEALTH AND SAFETY PLAN

Appendix B SAMPLE COLLECTION AND ANALYSIS  
STANDARD OPERATING PROCEDURES

Appendix C TEMPORARY SHED SPECIFICATIONS

# TABLE OF CONTENTS (*Continued*)

---

## FIGURES

Figure 2-1	Site Location Map .....	2-2
Figure 2-2	OU D Site S and IC-19 Well Location Map .....	2-3
Figure 2-3	Layout of Existing SVE System at OU D Site S.....	2-4
Figure 3-1	Process and Instrumentation Diagram.....	3-2
Figure 5-1	Site Layout .....	5-2
Figure 5-2	Electrical Distribution and Controls.....	5-3
Figure 8-1	Project Organization Chart.....	8-2
Figure 9-1	GAC Test Schedule .....	9-2

## TABLES

Table 2-1	Average Vapor Phase Contaminant Distribution for OU D Site S .....	2-6
Table 5-1	Sampling Schedule.....	5-6
Table 7-1	Sample Containers and Holding Times.....	7-2
Table 7-2	Field Instrumentation and Equipment Specifications .....	7-3
Table 8-1	Key Project Personnel and Telephone Numbers .....	8-3
Table 8-2	Quality Control Acceptance Criteria.....	8-7
Table 8-3	Laboratory Corrective Actions .....	8-18
Table 8-4	Typical Conditions and Corrective Actions for Field Parameters .....	8-19
Table 10-1	McClellan Management .....	10-1

## TABLE OF CONTENTS (*Continued*)

### ACRONYMS

GAC	Granular activated carbon
µg/kg	Micrograms per kilograms ✓
µg/L	Micrograms-per-liter
1,1,1-TCA	1,1,1 trichloroethane
1,1-DCE	1,1-dichloroethene
AFB	Air Force Base
BACT	Best available control technology
bgs	Below ground surface
CIH	Certified Industrial Hygienist
DoD	Department of Defense
DRE	Destruction and removal efficiency
DVM	Data Validation Manager
EPA	Environmental Protection Agency
HASO	Health and Safety Officer
HASP	Health and Safety Plan
HF	Hydrofluoric acid
IRPIMS	Installation Restoration Program Information Management System ✓
LM	Laboratory Manager
mg/kg	Milligrams-per-kilogram
mg/L	Milligrams-per-liter
MS/MSD	Matrix spike/matrix spike duplicate
NETTS	National Environmental Technology Test Site
NMOCS	Non-methane organic compounds
O&M	Operation and maintenance
OSHA	Occupational Health and Safety Administration
PCE	Tetrachloroethene

## TABLE OF CONTENTS (*Continued*)

---

PID	Photo-ionization detector
PM	Project Manager
ppmv	Parts-per-million by volume
PWS	Performance Work Statement
QA/QC	Quality Assurance/Quality Control
QAM	Quality Assurance Manager
QAPP	Quality Assurance Project Plan
RCRA	Resource Conservation and Recovery Act
RI/FS	Remedial investigation/feasibility study
RPD	Relative percent difference
s.f.	Square feet
scfm	Standard-cubic-feet-per minute
SMAQMD	Sacramento Metropolitan Air Quality Management District
SVE	Soil vapor extraction
TCE	Trichloroethene
USAF	U.S. Air Force
VOCs	Volatile organic compounds
WIP	Work Implementation Plan

# 1.0

# INTRODUCTION AND BACKGROUND

1 In accordance with contract No. F04699-97-D-0023, Delivery Order No. 3004, Metcalf  
2 & Eddy, Inc. (M&E) has been authorized to test microwave regenerated granular acti-  
3 vated carbon (GAC) as a treatment technology for vapor phase contamination remedia-  
4 tion at McClellan Air Force Base (AFB). M&E is teamed with a specialty subcontractor,  
5 CHA Corporation, who has previous experience in implementing the microwave regen-  
6 erated GAC technology. This document presents the test objectives, test procedures,  
7 sampling and analytical methods, quality assurance/quality control procedures, and  
8 health and safety issues related to the test.

## 9 1.1 PROGRAM OVERVIEW

---

10 McClellan AFB has implemented an aggressive program to find more cost effective en-  
11 vironmental clean up technologies. To this end, the Technology Integration group is re-  
12 sponsible for identifying and evaluating emerging or innovative remediation technolo-  
13 gies. As part of the McClellan AFB remediation program, the Air Force Base  
14 Conversion Agency provides funding to evaluate technologies, such as this one, that  
15 have the potential to reduce costs and provide more environmentally treatment alterna-  
16 tives than those currently in use at McClellan AFB.

17  
18 McClellan AFB was designated as a NETTS location in 1993. The Strategic Environ-  
19 mental Research and Development Program (SERDP) provides funding for infrastructure  
20 support to the Technology Integration group for the McClellan NETTS location. The  
21 NETTS program provides known test locations with established infrastructures for the  
22 pilot-scale to full-scale tests of emerging or innovative technologies that can potentially  
23 cut costs and significantly reduce risks associated with current cleanup processes. The  
24 technologies must be applicable to the Installation Restoration Program (IRP) efforts for  
25 the Air Force and other Department of Defense (DoD) facilities. The ultimate goal of the  
26 NETTS program is to accelerate the market availability of these new technologies.

## 27 1.2 TECHNOLOGY NEED

---

28 Since 1979, soil and groundwater contamination has been investigated at McClellan AFB  
29 and remediation is in progress at several sites on base. Volatile organic compounds  
30 (VOCs) constitute the most widespread and common subsurface contaminants at  
31 McClellan AFB, including: trichloroethene (TCE), tetrachloroethene (PCE),  
32 1,1-dichloroethene (1,1-DCE), 1,1,1-trichloroethane (1,1,1- TCA), and Freon® 113.

1 Soil vapor extraction (SVE) is one of the technologies in widespread use at McClellan  
2 AFB to remove VOCs from soil. These systems generate air streams which require  
3 emissions control, which is the focus of this test. McClellan AFB's basic intent in pur-  
4 suit of innovative technologies for emissions control is to identify and develop technolo-  
5 gies that will provide the following:

- 6 • Minimum 25% reduction in life-cycle costs as compared to current  
7 baseline treatment technologies.
- 8 • Low or no emissions of priority pollutants.
- 9 • Relatively lower capital and operation and maintenance (O&M) costs (as  
10 compared to treatment methods currently in use such as catalytic  
11 oxidation/carbon adsorption).
- 12 • Modular design to allow easy transfer of equipment between various SVE  
13 sites.

14 Microwave regenerated GAC has been identified as an innovative technology that may  
15 meet the above-stated requirements for treatment of extracted soil vapor. If testing is  
16 successful, McClellan AFB will evaluate potential applications for this technology.

### 17 1.3 REPORT ORGANIZATION

---

18 This Work Implementation Plan (WIP) is structured in accordance with the NETTS  
19 *Technology Demonstration, Workplan Guidance* document dated October 1996 and con-  
20 sists of the following elements:

- 21 • Section 1: INTRODUCTION AND BACKGROUND
- 22 • Section 2: SITE DESCRIPTION
- 23 • Section 3: TECHNOLOGY DESCRIPTION
- 24 • Section 4: OBJECTIVES
- 25 • Section 5: FIELD ACTIVITIES
- 26 • Section 6: PERMITTING AND REGULATORY COMPLIANCE
- 27 • Section 7: SAMPLING PLAN
- 28 • Section 8: QUALITY ASSURANCE PROJECT PLAN
- 29 • Section 9: SCHEDULE
- 30 • Section 10: MANAGEMENT AND STAFFING
- 31 • Section 11: REFERENCES



# 2.0 SITE DESCRIPTION

## 1 2.1 SITE LOCATION AND HISTORY

---

2 M&E is proposing to test the microwave regenerated GAC system at OU D Site S.  
3 McClellan AFB is located approximately 7 miles northeast of downtown Sacramento  
4 (Figure 2-1). OU D Site S is located in the northwestern portion of the base and shown on  
5 Figure 2-2.

6 Site S covers an area of approximately 9,000 square feet (s.f.) (0.23 acres) in OU D.  
7 Site S is one of 12 waste disposal pits in OU D and has been identified as a former fuel  
8 and solvent disposal pit. The waste in Site S is overlain by approximately 10 feet of soil  
9 and extends to a depth of approximately 28-feet below ground surface (bgs). The water  
10 table in this area is approximately 100-feet bgs.

11 Since 1993, a SVE system has been operating at OU D Site S to remove VOCs and other  
12 by-products from the vadose zone soil. The SVE system currently uses a catalytic oxida-  
13 tion emission control system to treat the vapors to destroy a minimum of 95 percent of the  
14 VOCs prior to being released to the atmosphere. This system also consists of a caustic  
15 scrubber designed to remove greater than 99 percent of the hydrochloric acid (HCl) and  
16 hydrofluoric acid (HF) generated by the destruction of the VOCs in the catalytic oxidizer.  
17 The contaminants currently present in the vapor stream at the highest concentrations con-  
18 sist of 1,1,1—TCA, TCE, PCE, and petroleum hydrocarbons.

19 The SVE system is currently extracting and treating vapors from six vapor wells at OU D  
20 Site S (VES 101, VES 102, VES 105, VES 106, VES 107, and VES 113) and one vapor  
21 well from Site IC 19 (VW 6001). The vapor well at Site IC 19 was connected to the SVE  
22 system at OU D Site S in June 1997. The location of the various vapor extraction wells  
23 and disposal pits are shown on Figure 2-2. The SVE system at OU D Site S currently op-  
24 erates at an air flow rate of 600 standard-cubic-feet-per minute (scfm) and since startup,  
25 has removed approximately 450,000 pounds (lbs) of VOCs from the vadose zone (URSG,  
26 1998b). The layout of the existing SVE system at OU D Site S along with the proposed  
27 positioning of the microwave regenerated GAC system is shown on Figure 2-3.

## 28 2.2 GEOLOGY

---

29 Reserved



SCALE IN MILES

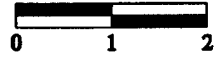

OU D  
SITE S  
& IC 19

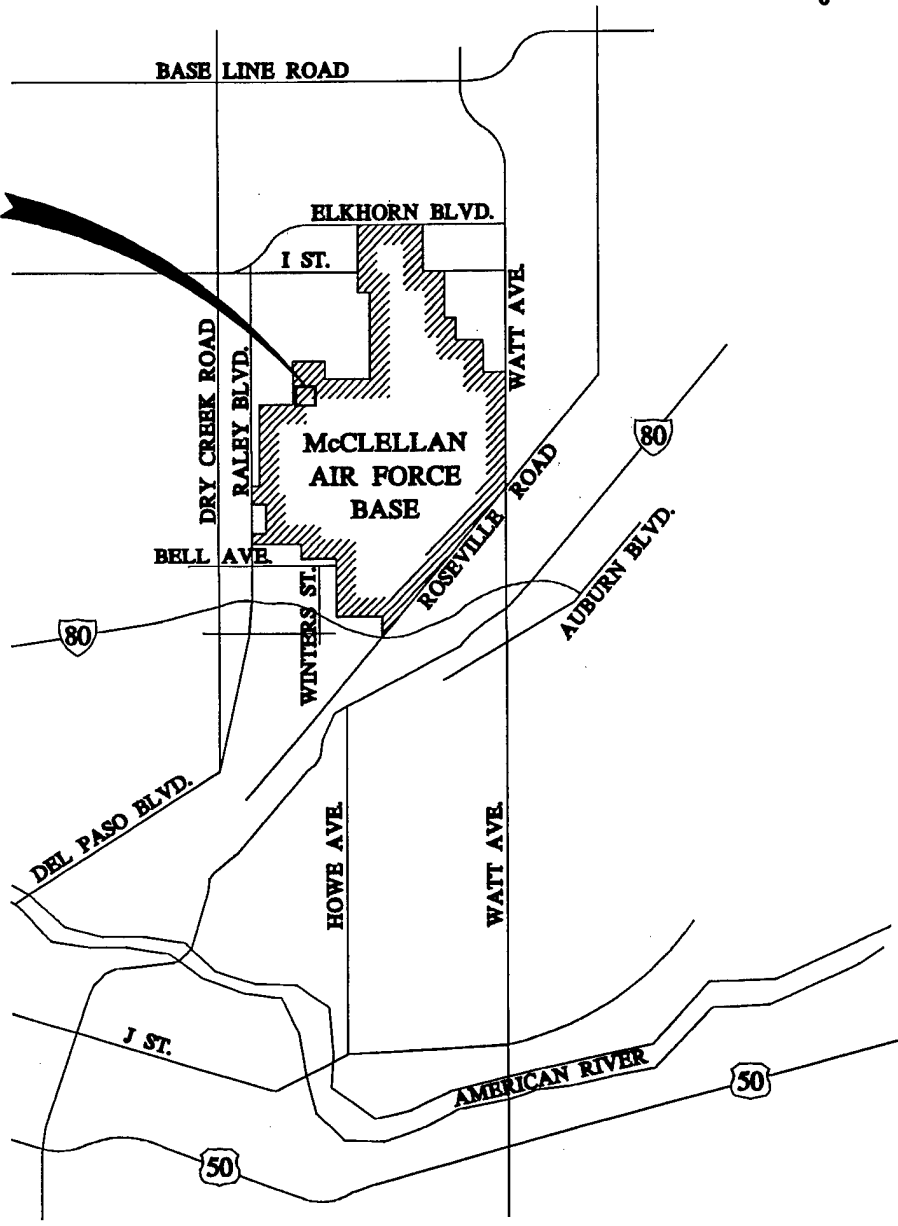

**McCLELLAN AIR FORCE BASE  
MICROWAVE REGENERATED GAC TEST**

**SITE LOCATION MAP**

**M&E** Metcalf & Eddy Inc.

**FIGURE  
2-1**

**JOB NO:  
024229**

**DATE:  
SEPT. 1998**

C:\24229\MCC\SITE\LOMP.DWG

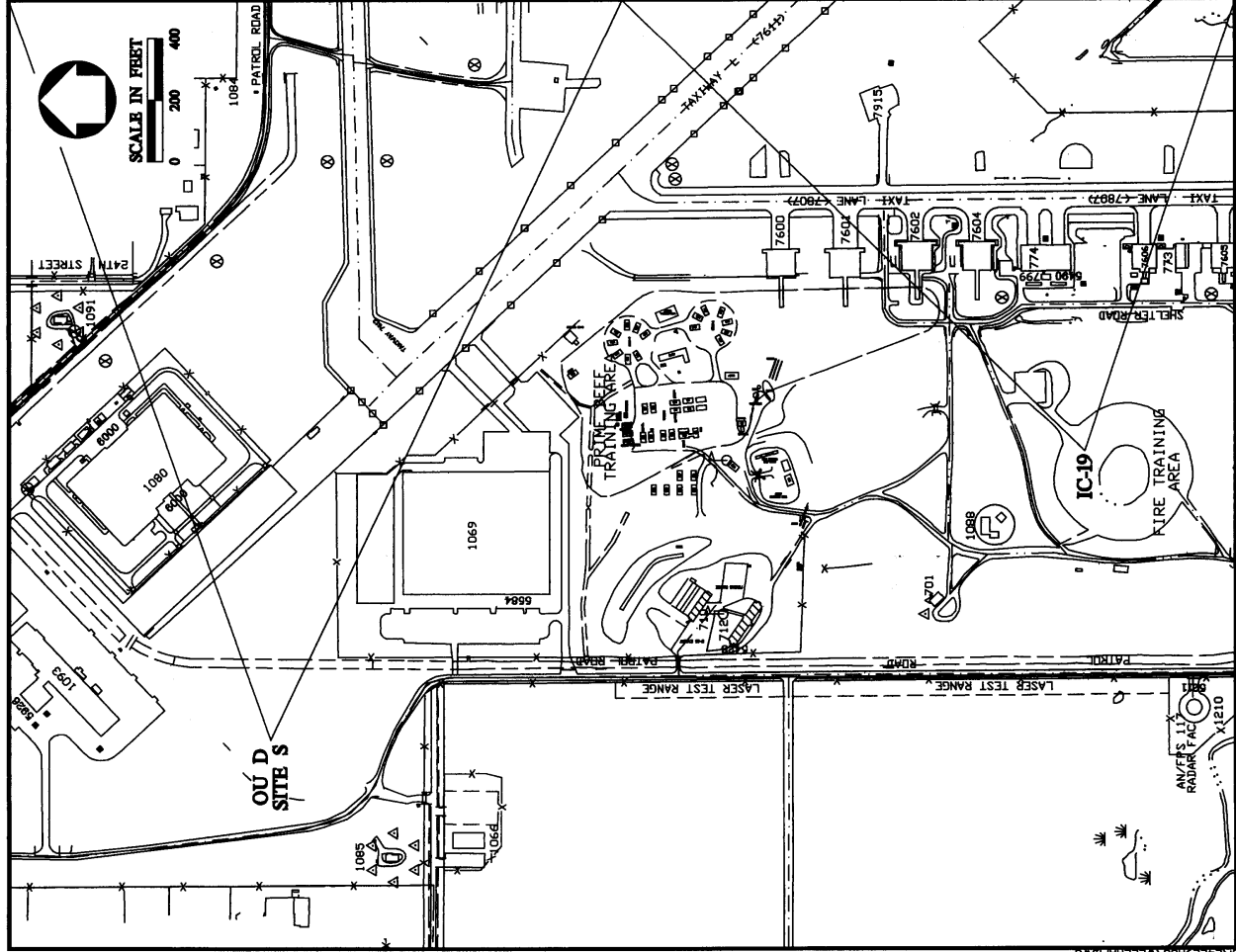
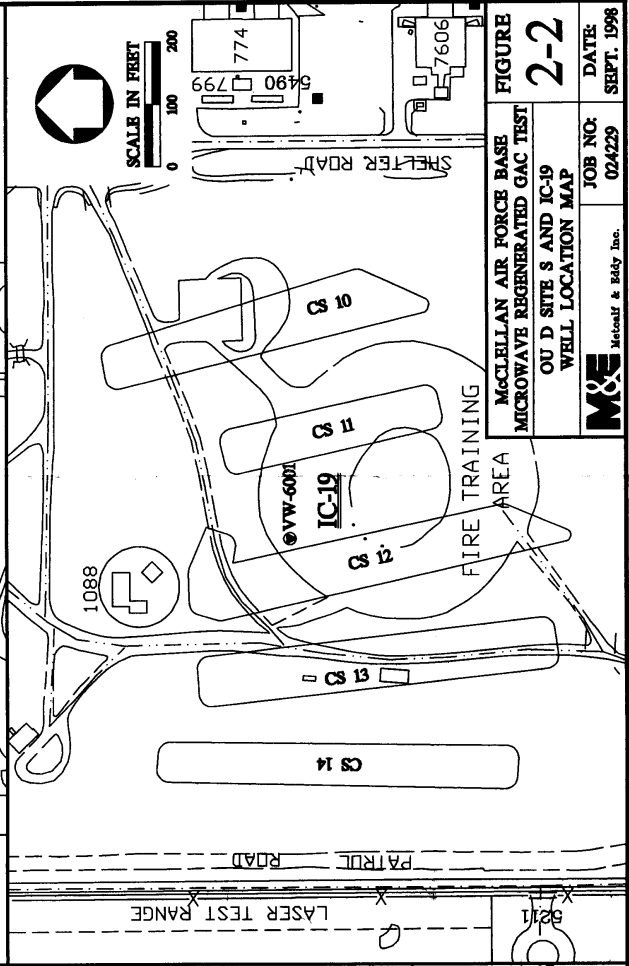
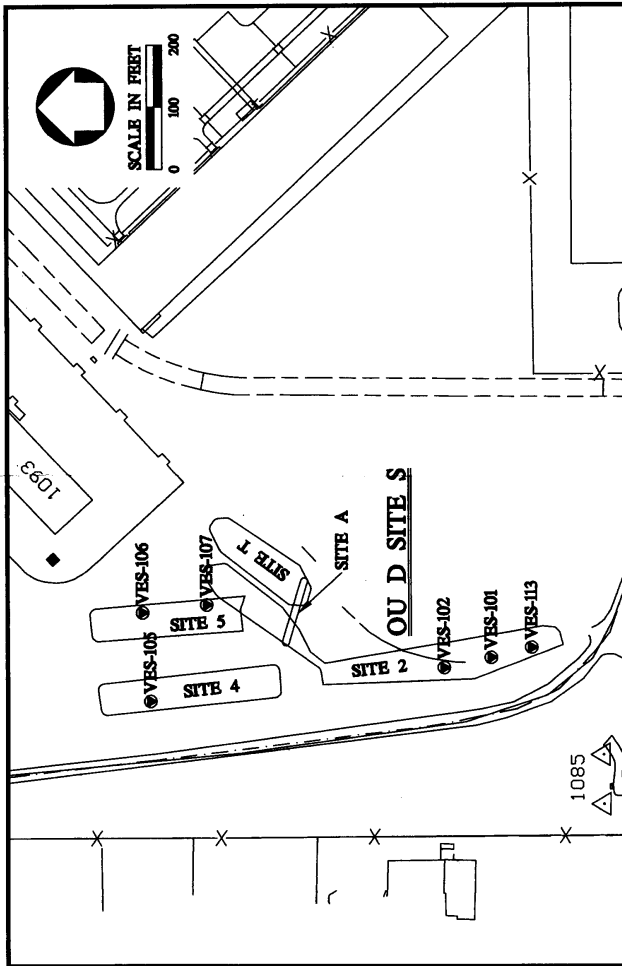



SCALE IN FEET  
0 4 8

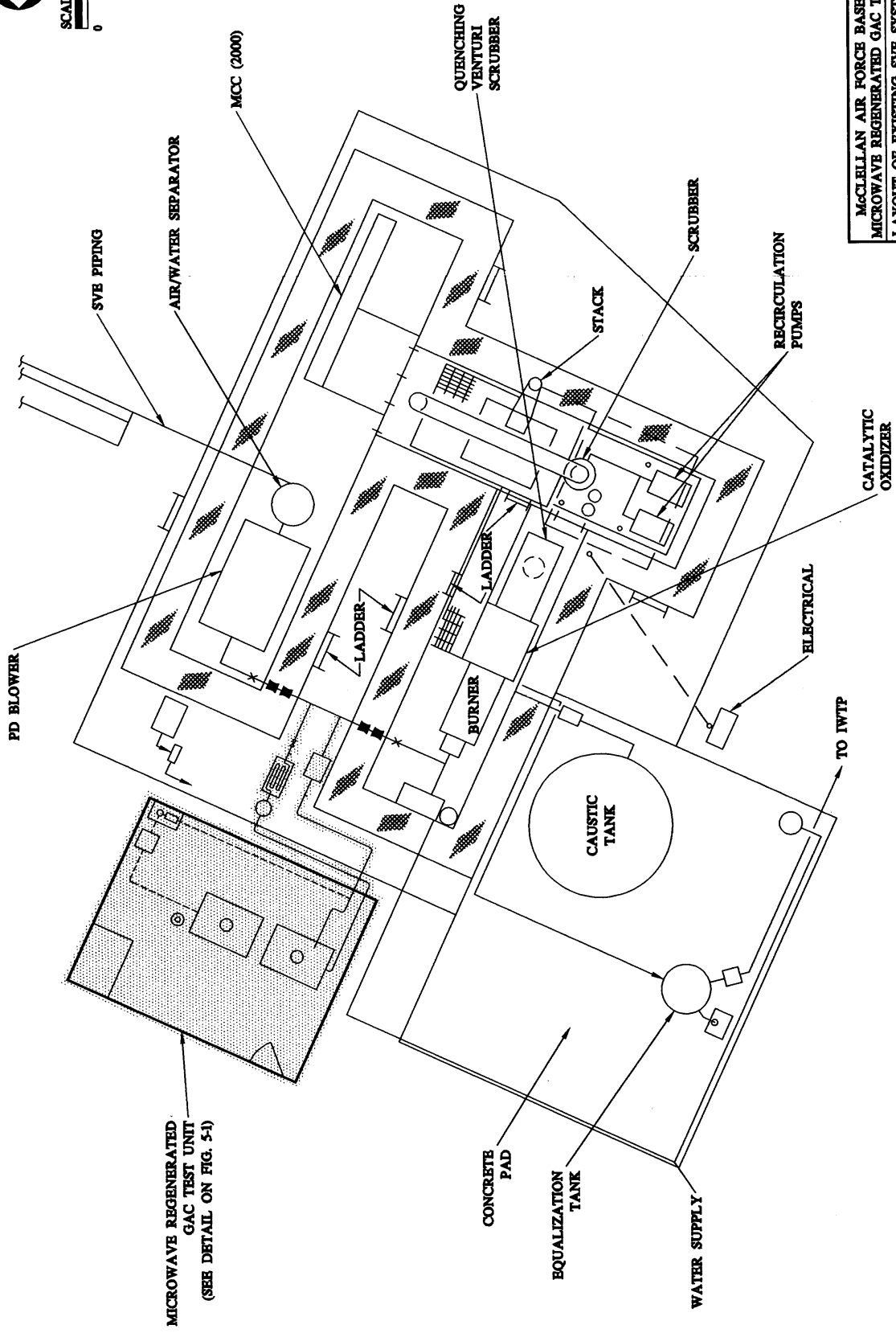

MICROWAVE REGENERATED  
GAC TEST UNIT  
(SEE DETAIL ON FIG. 5-1)

McCLELLAN AIR FORCE BASE MICROWAVE REGENERATED GAC TEST LAYOUT OF EXISTING SYE SYSTEM AT OU D SITE 5	<b>FIGURE</b> <b>2-3</b>	<b>DATE</b> SEPT. 1998
<b>M&amp;E</b> McQuinn & Eddy Inc.	<b>JOB NO.:</b> 024229	<b>DATE</b> SEPT. 1998

5/11/2008 09:30:00 AM

1     **2.3     HYDROGEOLOGY**

---

2     Reserved

3     **2.4     CONTAMINANT DISTRIBUTION**

---

4     As shown in Table 2-1, the primary contaminants of concern in the vapor influent include  
5     NMOCs and VOCs. Influent concentrations presented in Table 2-1 represent average  
6     concentrations of vapor samples collected during the monitoring period of January to  
7     March 1998. Influent mass emission rates were calculated using these concentrations and  
8     the corresponding airflow rate. It is anticipated that the contaminant constituents in the  
9     off-gas for the demonstration project will be consistent with the current contaminant  
10    make-up in the existing system.

11    In review of the SVE O&M progress report for June 1998 (USRG, 1998a), the overall  
12    contaminant extraction rate has decreased since June of 1996. From June 1996 to June  
13    1998, the contaminant extraction rate has decreased from approximately 6.5 pounds per  
14    hour (lb/hr) to 3.9 lb/hr. The current operating airflow rate is approximately 600 standard  
15    cubic feet per minute (scfm).



# 3.0 TECHNOLOGY DESCRIPTION

## 3.1 PRINCIPLES OF TECHNOLOGY

---

The CHA microwave-based gas cleanup process is designed to capture and destroy a wide variety of both chlorinated and non-chlorinated VOCs, many of which are commonly found at industrial and military sites. In addition, the CHA process also removes the pollutants sulfur dioxide (SO<sub>2</sub>) and nitrogen oxides (NO<sub>x</sub>) from flue gases. The technology has been successfully demonstrated at McClellan Air Force Base where NO<sub>x</sub> were removed from diesel engine exhaust gas. It is now being developed for use in the site remediation field. Due to the variability of both the type and the concentration of VOCs present in extracted soil vapor, it is essential to demonstrate the effectiveness of the microwave-based technology at McClellan AFB. This section describes the microwave regenerated GAC system provided by the CHA Corporation.

### 3.1.1 TECHNOLOGY SUMMARY

Activated carbon readily adsorbs VOCs and other pollutants, allowing removal efficiencies of at least 99 percent if sufficient carbon adsorbent and appropriate contact times are utilized. As the carbon continues to adsorb VOCs, the available adsorption sites are diminished and the adsorption efficiency decreases. To compensate for this decrease, the used carbon must be regenerated. Microwave energy can be used to rapidly regenerate used activated carbon. Activated carbon is also an excellent adsorber of microwave energy, allowing for more efficient and rapid regeneration of the adsorbent without having to heat the containment vessel or the purge gas. Microwaves can also be used to induce oxidation reactions over a variety of catalysts. When using microwaves, VOCs desorbed from carbon are efficiently oxidized over a catalyst at low bulk temperature. The process uses GAC to remove VOCs from the air stream, continuously regenerates the used GAC with microwaves, and destroys the VOCs desorbed from GAC.

The main components of the process system consist of:

- GAC moving-bed adsorber.
- microwave-based GAC regenerator.
- microwave-based oxidation catalyst reactor.
- acid gas scrubber.

The process flow diagram of microwave regenerated GAC test unit operation is shown on Figure 3-1.

100 CFM  $\Rightarrow$  D.I. CFM

1000% increase

if perfect

TCE

21,000 ppmv

PCE

23,000 ppmv

1,1,1 TCA

36,000 ppmv

Toluene

8,600 ppmv

VC

2200 ppmv

11 DCA

41,000 ppmv

- LEGEND**
- ① Carbon Adsorbent Moving Bed
  - ② Adsorbent Microwave Regeneration Device
  - ③ Carbon Adsorbent Storage Hopper
  - ④ Polish Reactor with Oxidizing Catalyst Bed
- TI Temperature Indicator
  - PI Pressure Indicator
  - FI Flow Indicator
  - DPI Differential Pressure Indicator
  - FCa Flow Control Valve (Air)
  - FCc Flow Control Valve (Carbon)
  - BFP Back Flow Preventer Valve
  - GAC Granulated Activated Carbon (Sampling Port)
  - COE Adsorbent Effluent (Sampling Port)
  - CSL Caustic Scrubber Liquid (Sampling Port)
  - COI Adsorbent Influent (Sampling Port)

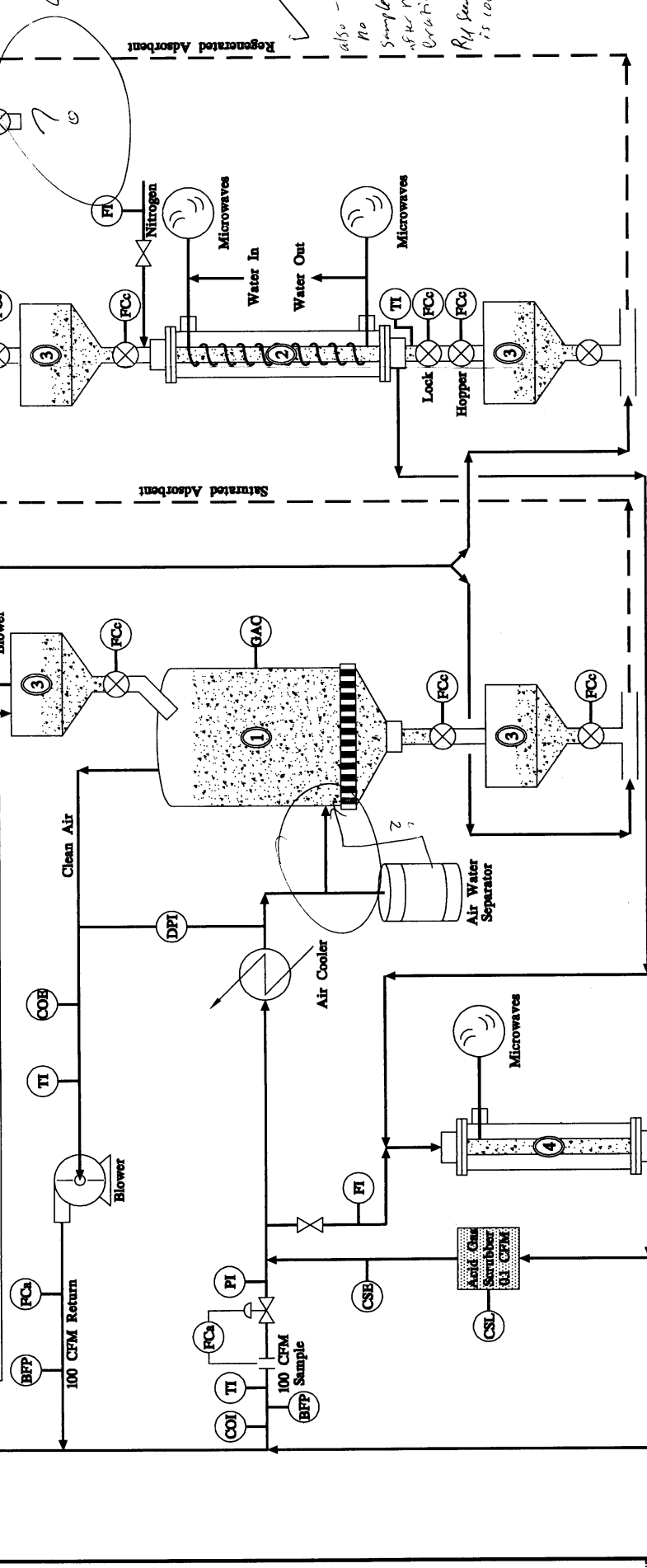

Soil Vapor Extraction  
Air Source Line  
Approx. 800 CFM

600?

Note: Individual equipment specifications are presented in Table 3-1

Where?

FIGURE 3-1  
McCLELLAN AIR FORCE BASE  
MICROWAVE REGENERATED GAC TEST  
PROCESS & INSTRUMENTATION  
DIAGRAM

M&E  
Heston & Hedy Inc.

JOB NO: 024229  
DATE: SEPT. 1998

also -  
No  
Sample  
- 5 K rps -  
Crack  
Ry Seal Stream  
is 100%

1        3.1.2    GAC MOVING-BED ADSORBER

2        The air stream containing hydrocarbon vapors is treated continuously through the moving-bed  
3        adsorber. In the adsorber, the solvent vapors are removed from the process gas by adsorption  
4        onto the GAC. The air stream containing hydrocarbon vapors from existing SVE systems is  
5        introduced through two 2-inch-inlet manifolds and travels first through a refrigerated com-  
6        pressed air dryer and then upward through the adsorber. The regenerated GAC is continu-  
7        ously fed throughout the adsorption unit via a feed hopper at the top and travels downward.

*non-adsorbing  
compounds?*

8        The GAC becomes progressively more loaded with VOCs as it flows downward through the  
9        adsorber until it reaches the bottom. The used GAC exits through a lock hopper valve at the  
10       bottom of the adsorber and is transported to the regenerator feed hopper by a vacuum pump.  
11       The treated air is then returned to the SVE system.

12       3.1.3    MICROWAVE GAC REGENERATOR

13       The GAC loaded with VOCs is fed by a feed hopper at the top and exits through a lock hop-  
14       per valve at the bottom of the regenerator. The regenerator operates as a moving-bed and re-  
15       generates the used GAC by microwave energy. The microwaves cause the VOCs to rapidly  
16       desorb and return to the vapor phase. The VOCs are removed from the bottom of the regen-  
17       erator by a small, constant stream of nitrogen purge gas injected at the top of the regenerator.  
18       The regenerated GAC is then returned to the top of the adsorber. The GAC is transferred  
19       between the two systems by two pneumatic conveyors, which are periodically operated to  
20       transfer the carbon when the receiving hopper is full.

*AT?*

21       3.1.4    MICROWAVE OXIDATION CATALYST REACTOR

22       The microwave catalyst reactor is packed with an oxidizing catalyst of platinum (Pt) and palla-  
23       dium (Pd) coated onto alumina beads impregnated with 25 percent 800-mesh silicon carbide  
24       (SiC). The nitrogen stream containing VOCs removed from the regenerator is mixed with air  
25       and flows into the top of the oxidation catalyst reactor. Materials such as VOCs respond to mi-  
26       crowave energy through two mechanisms; dipole rotation and ionic conduction. The response  
27       can be through a combination of these two mechanisms or just one of the two. Dipole rotation  
28       works on electrically neutral polar molecules with spatially separated positive and negative  
29       charges. The molecules exposed to the oscillating field generated by the microwave respond  
30       by rotating their respective polar ends in the direction of the increasing amplitude. The result-  
31       ing molecular friction generates heat instantaneously and uniformly throughout the compound.  
32       Molecules also interact with microwaves through ionic conduction through an induction phe-  
33       nomenon. The microwave's electrical field attracts the free ions of the compound and colli-  
34       sions with the un-ionized molecules generate kinetic energy in the form of heat. In addition to  
35       heating effects from microwave interaction, some molecules may undergo chemical reactions  
36       at unusually low temperatures. The microwaves and catalyst work together to effectively oxi-

*PCE?*

1 dize VOCs into carbon dioxide (CO<sub>2</sub>), water (H<sub>2</sub>O), and HCl. The liquid effluent containing  
2 HCl (and possibly hydrofluoric acid [HF]) leaves at the bottom of the reactor and flows into  
3 the acid gas scrubber.

### 4 3.1.5 ACID GAS SCRUBBER

5 The acid gas scrubber contains approximately 5 percent by weight sodium hydroxide (NaOH)  
6 solution. The gas containing HCl flows through a perforated pipe in the scrubber and leaves at  
7 the top of the scrubber. HCl and possibly HF reacts with NaOH and the end products are so-  
8 dium chloride (NaCl), sodium fluoride (NaF), and H<sub>2</sub>O. The effluent gas is returned to the ad-  
9 sorber.

## 10 3.2 TECHNOLOGY APPLICABILITY

---

11 Microwave-based gas cleanup technology is suitable for capturing and destroying a wide vari-  
12 ety of both chlorinated and non-chlorinated VOCs. Relatively volatile compounds, such as  
13 solvents, are the most applicable targets for the microwave process because the GAC can be  
14 easily regenerated with low microwave power. The following compounds can be treated  
15 with the microwave process:

16 Perchloroethylene	Chlorobenzene	Trichloroethane
17 Dichlorobenzene	Methyl ethyl ketone	Benzene
18 Methylene chloride	Ethyl benzene	Carbon tetrachloride
19 Toluene	1,1,1-trichloroethane	Xylene (o-, m-, and p-)
20 Acetone	Freon <sup>®</sup> 113	Chloroform
21 Hydrocarbons		

## 22 3.3 ADVANTAGES AND LIMITATIONS OF TECHNOLOGY

---

### 23 3.3.1 ADVANTAGES

24 The microwave process offers a number of advantages over the available conventional treat-  
25 ment technologies. The microwave technology gives the option of either recovering or de-  
26 stroying the solvents. Since the solvents recovered from extracted soil vapor are not very  
27 useful, it is much better to destroy the solvents rather than recover them. The GAC moving-  
28 bed provides greater than 99 percent solvent removal efficiency. The use of microwave energy  
29 allows a continuous regeneration of GAC in place, as well as a minimum loss of GAC. Addi-  
30 tionally, less energy is used in the regeneration process because the bulk temperature is much  
31 lower than conventional steam regeneration process. Furthermore, no secondary pollutants,  
32 such as NO<sub>x</sub>, are produced. Microwave catalytic oxidation of solvents eliminates any need for

---

1 handling and disposal of recovered solvents. Finally, the volume of gas produced from regen-  
2 eration in need of scrubbing is only a fraction of the volume of product gas resulting from con-  
3 ventional oxidation methods.

4 **3.3.2 LIMITATIONS**

5 The GAC adsorber is used as an accumulator vessel in order to accumulate contaminants of  
6 concern that are present in the influent vapor stream. The efficiency of the microwave regen-  
7 erated GAC system will be determined by how well the GAC adsorbs these contaminants. It is  
8 possible for compounds that do not readily adsorb to GAC (e.g., chlorine gas, fluorine gas,  
9 methane, etc.) to pass through the GAC adsorber and subsequently not be treated by the mi-  
10 crowave reactor.

*friable GAC + loss over time (baghouse)*

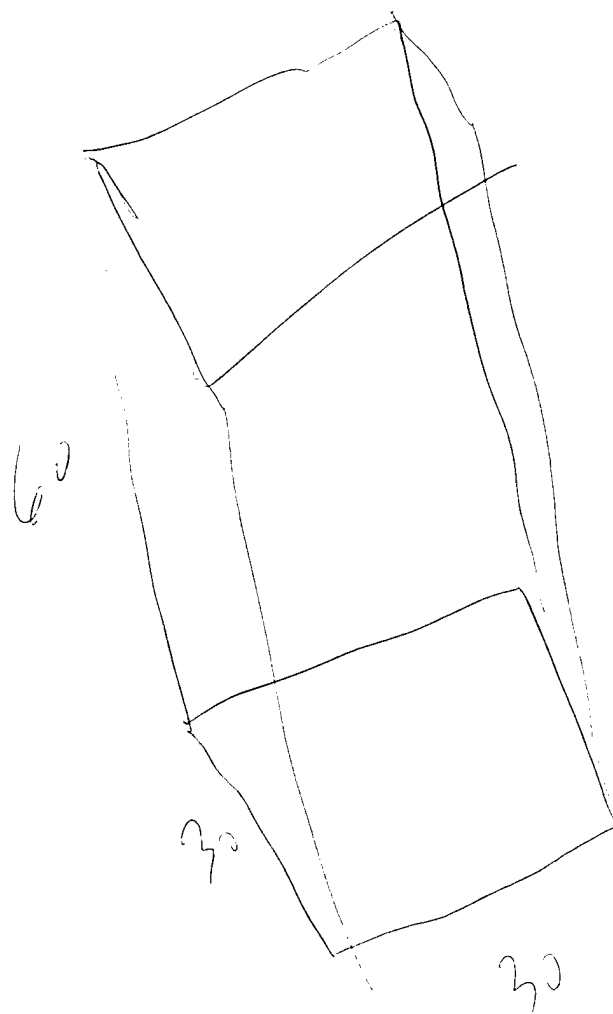

# 4.0 OBJECTIVES

## 1 4.1 GENERAL OVERVIEW

2 The proposed test for OU D Site S will include slipstreaming a microwave regenerated  
 3 GAC treatment system prior to the existing catalytic oxidation unit. The microwave regen-  
 4 erated GAC treatment system will then be operated and monitored for a period of 3  
 5 months. At the end of 3 months, M&E will evaluate the cost and performance of the mi-  
 6 crowave regenerated GAC system and compare them to other standard treatment tech-  
 7 nologies. The cost comparison will be made at full-scale operation (250 scfm) including  
 8 capital costs, power consumption, and operation and maintenance cost over a 10-year pro-  
 9 jected lifetime.

*✓*  
*Slip stream @ 600 scfm?*

## 10 4.2 DESCRIPTION OF TECHNOLOGY PROCESS

11 The technology process proposed involves slipstreaming polyvinyl chloride (PVC) piping  
 12 onto existing flanges located on the positive pressure side of the existing SVE system. A  
 13 positive displacement blower will be used to pull a slipstream of 100 scfm from the existing  
 14 SVE system, through the microwave regenerated GAC test unit and then back into the ex-  
 15 isting SVE system upstream of the catalytic oxidizer.

*not 110  
 -140°F*

*Section 3*

16 At the microwave regenerated GAC test unit, the contaminated vapors will be directed  
 17 through an air-water separator and then to an adsorber equipped with 600-pounds of new  
 18 GAC. The adsorber vessel is made of aluminum and is 30 square inches at the base and 60  
 19 inches high. The off gas from the adsorber is then directed back to the existing SVE sys-  
 20 tem upstream of the catalytic oxidizer. The spent GAC will be batch-cycled through the  
 21 microwave regenerator where the contaminants will be desorbed. The offgas from the mi-  
 22 crowave regenerator is directed through the microwave oxidation catalyst reactor via a  
 23 constant stratum of nitrogen purge gas where the contaminants are destroyed. The vapor  
 24 exiting the catalyst bed are directed through the acid gas scrubber, and then back to the ad-  
 25 sorber. The airstream temperature, pressure, and flow associated with the test unit are  
 26 measured and recorded continuously using an on-site process controller/date acquisition  
 27 system (DAS) complete with a personal computer.

*chiller?*  
*Specs on GAC?*  
*Capacity?*

28 Soil vapor sampling ports will be installed to assess treatment system performance prior to  
 29 GAC treatment (adsorber influent, COI), following GAC treatment (adsorber effluent,  
 30 COE) and following the scrubber prior to re-entry into the adsorber (scrubber effluent,  
 31 CSE). Sample ports are shown on Figure 3-1.

### 4.3 STATEMENT OF DEMONSTRATION'S OBJECTIVES

The objectives of this microwave regenerated GAC test are to:

- demonstrate the performance and efficiency of the GAC system to process a SVE off-gas stream of VOCs as well as other co-contaminants using microwave regeneration of the GAC media.
- quantify cost data for the technology under field conditions encountered at McClellan AFB.
- determine the expected useful life of GAC that will be regenerated using microwave energy.
- verify that the performance of the treatment system meets BACT standards set forth by regulatory agencies.

### 4.4 TEST PLAN

This section presents a summary of the test plan including the main elements of the test that will contribute to achieving the previously stated objectives.

#### 4.4.1 DEMONSTRATE SYSTEM PERFORMANCE EFFICIENCY

To demonstrate the efficiency of the microwave regenerated GAC system, the slipstream vapor from OU D Site S will be delivered to the microwave regenerated GAC test system at 100 scfm. The test will be conducted for a period of 3 months. During this 3-month period, approximately 15 complete GAC regenerations are anticipated. This number of regenerations is based on a mass contaminant loading rate of 0.6 lbs/hr from the existing SVE system at OU D Site S (URSG, 1998b). Each regeneration will represent 600-pounds of GAC.

Specifically, the performance and efficiency of the microwave regenerated GAC system will be evaluated by collecting and analyzing the following samples:

- Weekly sampling of the air stream leading to the test unit (influent). Samples will be analyzed for volatile organics (TO-14A), semi-volatile organics (TO-13), and non-methane organics (TO-12).
- Weekly sampling of the air stream, leaving the GAC media (effluent). Samples will be analyzed for volatile organics (TO-14A), semi-volatile organics (TO-13), and non-methane organics (TO-12).

Table 2.1 over to 2 1/2 hrs @ 580 scfm

add to loading time

- 1 • Weekly sampling of the air stream leaving the scrubber prior to re-entry into the  
2 existing SVE system (scrubber effluent). Samples will be analyzed for volatile  
3 organics (TO-14A), semi-volatile organics (TO-13), and non-methane organics  
4 (TO-12).
- 5 • One liquid sample of the scrubber solution will be collected at the end of the test.  
6 This sample will be analyzed for volatile organics (Environmental Protection  
7 Agency [EPA] 8260A), semi-volatile organics (EPA 8270B), petroleum  
8 hydrocarbons (EPA Method 5030, 3550/8015 Mod.), and pH.
- 9 • One sample of the regenerated GAC will be collected at the end of the test. This  
10 sample will also be analyzed for volatile organics (EPA 8260A), semi-volatile  
11 organics (EPA 8270B), petroleum hydrocarbons (EPA Method 5030, 3550/8015  
12 Mod.), and pH.
- 13 • ~~One-day continuous~~ <sup>? Cat unit??</sup> emissions testing will be conducted on the air stream leaving  
14 the GAC vessel. Potential by-products to be tested for will include chlorine,  
15 hydrogen chloride, and hydrogen fluoride (EPA 26A), phosgene (EPA T0-6), oxides  
16 of nitrogen (CARB 100), and ozone (NIOSH S8).

Virgin GAC  
tested for  
comparison?

17 Operating status will be documented throughout the microwave regenerated GAC demon-  
18 stration. During each site visit, the technician will record the amount of operating time  
19 since the previous field visit. Cumulative downtime will be documented and categorized  
20 as isolated occurrences unrelated to system performance or disruptions inherent to the  
21 technology. Shutdowns caused by occurrences that are unrelated to the microwave regen-  
22 erated GAC system will be subtracted from both the downtime and total test duration time.

#### 23 4.4.2 QUANTIFY COST DATA

24 During the 3-month test period, the operating costs will be documented. Specific cost  
25 items will include materials, labor, analytical, utility usage, and waste handling/disposal.

#### 26 4.4.3 DETERMINE THE EXPECTED USEFUL LIFE OF REGENERATED 27 GAC

28 To demonstrate the expected useful life of the regenerated GAC, the adsorption capacity  
29 and surface area of the GAC will be determined prior to the start of the test and again at  
30 completion.

Mass in bag house ?

#### 31 4.4.4 VERIFY THAT SYSTEM PERFORMANCE MEETS BACT

32 The mass of contaminants entering and exiting the microwave regenerated GAC system  
33 will be monitored to provide data for mass balance calculations. The composition and

1 mass of liquid product recovered will also be estimated by analyzing the scrubber liquid at  
2 the end of the test. In addition to the influent/effluent vapor samples, and liquid samples,  
3 one sample of the final regenerated GAC will be collected and analyzed. If discernable,  
4 this data will also be used as part of the mass balance calculation.

5 Mass balance calculations will be presented showing the mass of constituents entering the  
6 system in vapor phase and then leaving the system as a vapor-phase emission, liquid-phase  
7 product, or retained on the regenerated GAC as follows:

- 8 • The mass of VOCs entering and leaving the test unit as a vapor will be calculated  
9 based on flow rate and chemical analyses results on influent and effluent vapor  
10 samples.
- 11 • The mass of liquid will be calculated based on analytical results and container  
12 capacity.  
*liquid from GAC regen & cont in separator*
- 13 • The mass of contaminant remaining on the regenerated GAC will be calculated  
14 based on analytical results and GAC weight.

15 In addition to mass balance calculations, BACT will be verified by performing a paired T-  
16 test on reactive organic compounds (ROCs) in the vapor stream.

#### 17 4.5 TECHNOLOGY PARAMETERS EVALUATION

18 This section describes the factors that can affect the performance of the treatment process  
19 and will need to be carefully monitored. Potential factors include:

- 20 • Significant fluxuations in vapor phase contaminant concentrations entering the  
21 microwave regenerated GAC test unit.
- 22 • Interruptions to electrical service.
- 23 • Appearance of hydrofluoric acid (HF).

#### 24 4.6 DATA ANALYSIS AND INTERPRETATION

25 To assess the performance of the microwave regenerated GAC test relative to the objec-  
26 tives, the following will be performed:

- 27 • The performance of the analytical data collected will be evaluated in accordance  
28 with the analytical quality control acceptance criteria presented in Section 8.0 and  
29 summarized in Table 8-1.
- 30 • The overall operating time of the test unit will be documented to show that the  
31 microwave regenerated GAC system can achieve more than 90 percent operation

*Daily flow not seen w/ weekly sampling*

1 time after startup until the completion of the test. Percent operation time will be  
2 calculated by dividing the adjusted operating time by the adjusted test duration.

- 3 • The costs of the test will be compiled, tabulated, and discussed relative to other  
4 conventional GAC systems including onsite thermally regenerated GAC, offsite  
5 regeneration, and flameless thermal oxidation. It is M&E's understanding that  
6 McClellan AFB will provide a standardized set of hypothetical site conditions to  
7 normalize the comparison of microwave regenerated GAC with other standard  
8 technologies. The microwave regenerated GAC test will be used to extrapolate full-  
9 scale operation (250 scfm) under similar conditions.
- 10 • To demonstrate the expected useful life of the regenerated GAC, the percentage of  
11 GAC surface area depletion and adsorption capacity will be determined. These  
12 percentages will be used to calculate GAC requirements during full-scale operations  
13 (250 scfm). These requirements will then feed back into the cost analysis. These  
14 costs will then be compared to spent GAC disposal costs. ? ✓
- 15 • Using the results of the emissions monitoring, the mass of contaminants will be  
16 extrapolated to estimate an expected yearly discharge mass at full-scale operations  
17 (250 scfm). This data will be compared with other treatment systems including  
18 onsite thermally regenerated GAC offsite regeneration and flameless thermal  
19 oxidation.
- 20 • To verify that the microwave regenerated GAC system meets BACT, destruction  
21 removal efficiencies (DREs) will be calculated and compared to the desired BACT  
22 treatment criteria of 95 percent (telephone conversation with Jorge DeGuzman,  
23 Program Coordinator, SMAQMD). DRE is the percent reduction observed in the  
24 concentration of a specific analyte between the influent and effluent air streams.  
25 DRE is calculated as follows: ✓

26  
27  
28  
29

$$\% \text{ DRE} = \frac{(\text{Mass VOCs}) \text{ influent} - (\text{Mass VOCs}) \text{ effluent}}{(\text{Mass VOCs}) \text{ influent}}$$

30 DREs for NMOCs and TPH will be calculated in a similar manner as the VOCs. A statis-  
31 tical analysis will be performed to verify that the calculated DREs meet BACT require-  
32 ments.

# 5.0 FIELD ACTIVITIES

## 5.1 PRE-OPERATIONAL CHARACTERIZATION

---

McClellan AFB has implemented removal action for soils under a Basewide Soil Vapor Extraction Engineering Evaluation/Cost Analysis and containment actions under a Basewide Groundwater Interim Record of Decision. Site conditions at test OU D Site S have been reviewed and fully characterized and no changes have occurred that would significantly change the composition. No additional data will be needed prior to operation of the microwave regenerated GAC test. Therefore, further characterization of the SVE effluent is not necessary.

## 5.2 SYSTEM INSTALLATION

---

M&E has prepared the following drawings to show the installation and configuration of the microwave regenerated GAC test unit at OU D Site S.

- Test layout diagram (Figure 5-1)
- Process and Instrumentation Diagram (Figure 3-1)
- Electrical Distribution and Controls (Figure 5-2)

These drawings will be used by McClellan AFB personnel to obtain the required base clearances and permits. The drawings will also be used by M&E to construct the system. McClellan AFB personnel will be required to install electrical hook-up (230 volts, 3 phase, 100 amperes) and a dedicated telephone line to within 50 feet of the test unit prior to system installation and startup. McClellan AFB personnel shall also provide water service at or near the treatment area. Prior to any storage of hazardous materials (i.e., sodium hydroxide), M&E will coordinate with McClellan AFB personnel to fill out the appropriate paperwork.

After receiving base clearances, M&E will procure the equipment and supplies to install the temporary test facility. As indicated on the Test Layout Diagram (Figure 5-1), PVC piping will be attached to existing flanges on the SVE system and extended to the microwave regenerated GAC test unit. A positive displacement Spencer-Turbine® blower will be installed to pull a slip stream vapor flow of approximately 100 scfm from the existing SVE system through the microwave regenerated GAC system. Following a single pass through the microwave regenerated GAC, the treated air will be routed back to the SVE system upstream of the catalytic oxidizer. The microwave regenerated GAC

**SITE LAYOUT**



**LEGEND**

- ① CARBON ADSORBENT MOVING BED
- ② ADSORBENT MICROWAVE REGENERATION REACTOR
- ③ CARBON HOPPER BOXES
- ④ MICROWAVE CATALYST BED
- ⑤ ACID GAS SCRUBBER
- ⑥ COMPUTER STATION
- ⑦ BLOWER
- ⑧ BACK FLOW PREVENTER VALVE
- ⑨ AIR COOLER
- ⑩ SAMPLE PORT
- ⑪ AIR WATER SEPARATOR
- ⑫ CONDENSER
- ⑬ CARBON TRANSFER PNEUMATIC PUMPS
- ⑭ ISOLATION VALVE
- ⑮ CONDENSATE PUMPS (2)
- ⑯ CYCLONE
- ⑰ N2 GAS CYLINDER

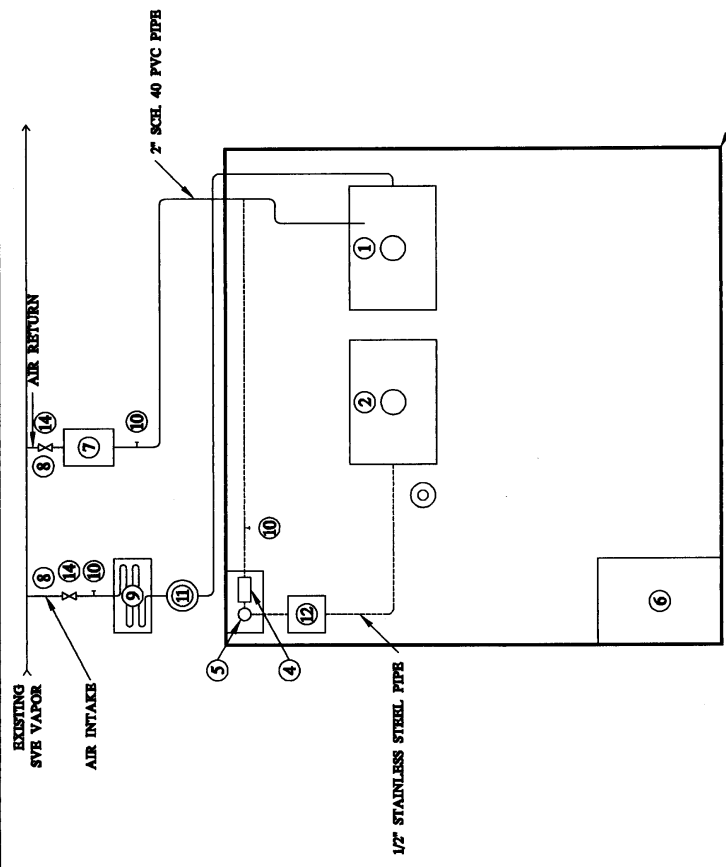

**TOP VIEW**

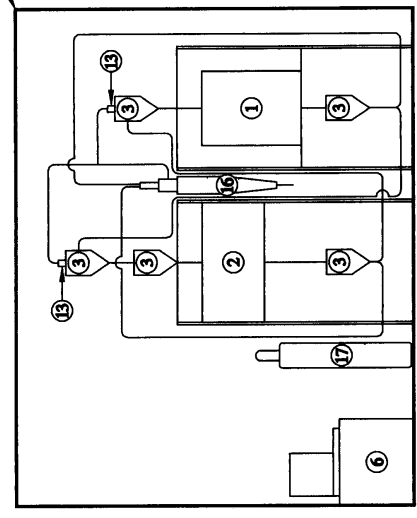

**FRONT VIEW**

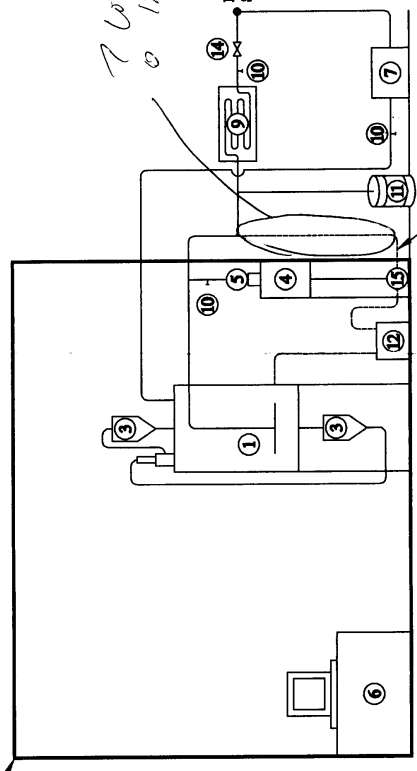

**SIDE VIEW**

TEMPORARY BUILDING  
 (SEE APPENDIX C  
 FOR DETAILS)

*Condensate  
 line? when  
 go*

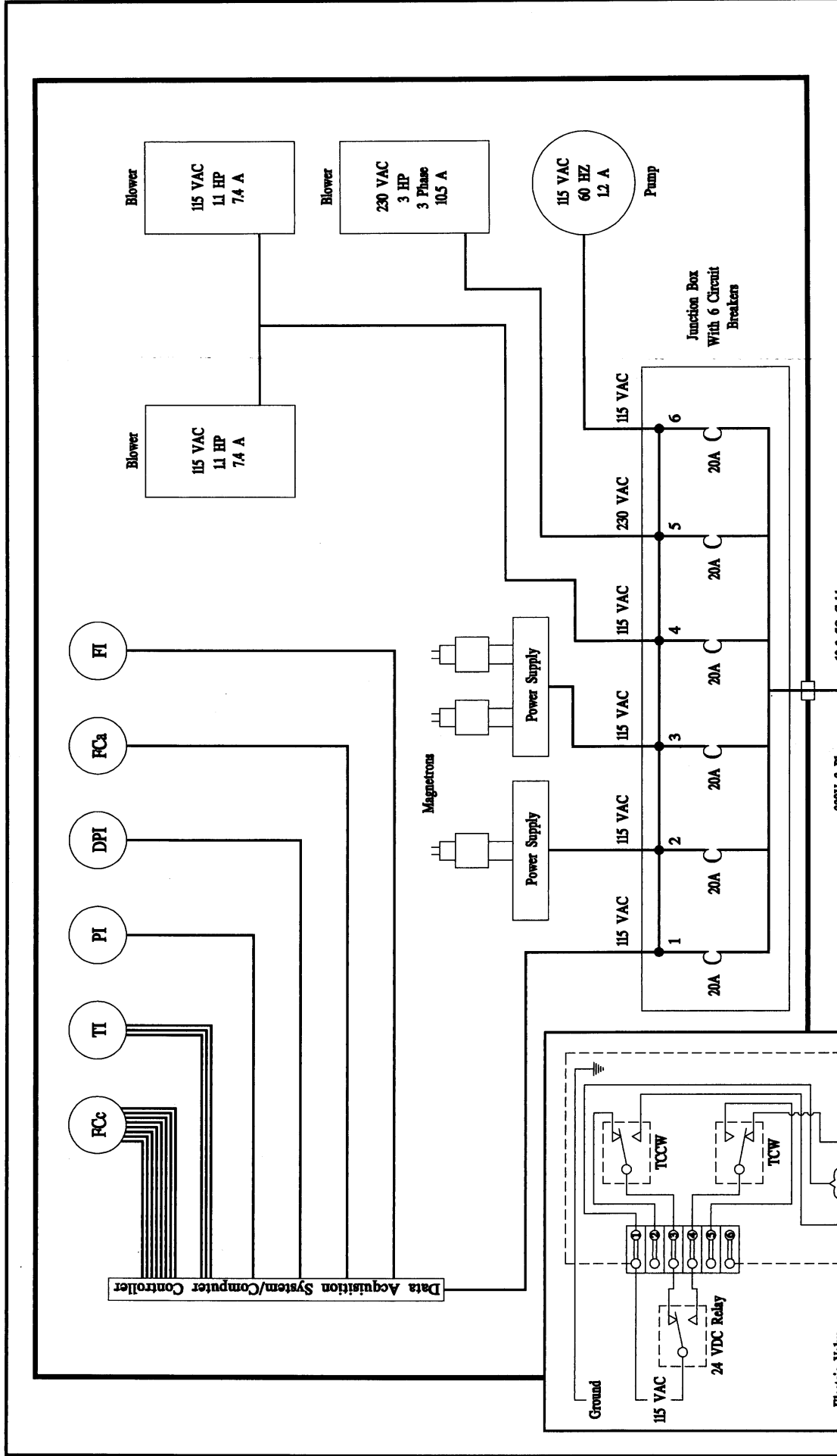

McLELLAN AIR FORCE BASE  
 MICROWAVE REGENERATED GAS TEST  
 ELECTRICAL DISTRIBUTION  
 AND CONTROLS

**FIGURE 5-2**

DATE: SEPT. 1998  
 JOB NO: 024229  
 M&E Metallif & Eddy Inc.

024229-01-001A-010

1 system will be loaded with new unused GAC prior to site mobilization. A BigTop®  
2 temporary shed approximately 20 feet (ft) by 20 ft equipped with a 16 ft high ceiling will  
3 also be installed to house the test unit (details provided in Appendix C).

4 A licensed electrician will connect the microwave regenerated GAC test unit to the electri-  
5 cal supply at OU D Site S. In review of the O&M manual (URSG, 1998a), several  
6 alarms/controls have been installed on the existing SVE system in the event of system fail-  
7 ure (i.e., low or high temperature at catalytic oxidizer, low pressure at process fan, etc.). As  
8 such, the microwave regenerated GAC test unit will also be equipped with an automatic  
9 shutdown mode. The DAS will be programmed to automatically shutdown the demonstra-  
10 tion unit concurrently with any shutdown of the existing OU D Site S system. Specifically,  
11 the DAS will be wired directly into the existing 120-volt relay process damper valve. This  
12 will automatically shut the demonstration unit down during any alarm condition associated  
13 with the OU D Site S system. Figure 5-2 shows the electrical distribution and controls of  
14 the demonstration unit.

### 15 5.3 SYSTEM OPERATION

16 Operation of the microwave regenerated GAC test unit will be conducted in two phases: (1)  
17 Startup, and (2) Test. The microwave regenerated GAC test unit will be checked out and  
18 adjusted during the startup phase to make sure the system is fully operational before begin-  
19 ning the actual test phase of the program.

#### 20 5.3.1 STARTUP PHASE

21 The purpose of the startup phase is to adjust the microwave regenerated GAC test unit op-  
22 erating parameters so that the test unit meets or exceeds the minimum BACT criteria of 95  
23 percent DRE under initial VOC concentration conditions. Startup testing and system ad-  
24 justments are scheduled for 5 days. The system performance will be adjusted by varying  
25 the following process and operating parameters:

- 26 • Process gas flow rate through the adsorber. Initially, a process gas flow rate of  
27 approximately 100 scfm will be adjusted manually by varying the speed of the  
28 auxiliary positive displacement Spencer-Turbine® blower or by adjusting the  
29 control valve on the process gas stream inlet. Throughout the demonstration, the  
30 DAS unit will maintain the pre-programmed flow rate by automatically opening  
31 and closing control valves to compensate for pressure and flow variations. The  
32 Rosemont® air flow meter has built in corrections for temperature and will be  
33 calibrated by the manufacturer. Measured air flow rates will be periodically  
34 compared with available pump curve data (pressure vs. flow) provided by the  
35 blower manufacturer to ensure accurate readings. Flow rates are not expected to  
36 vary substantially during the test.

**SAMPLING SCHEDULE**

Parameter	Method	Sample Location	Week 1 Startup Phase							Test Phase							Location Total	
			Day 1	Day 2	Day 3	Day 4	Day 5	Wk #2	Wk #3	Wk #4	Wk #5	Wk #6	Wk #7	Wk #8	Wk #9	Wk #10		Wk #11
<b>VAPOR SAMPLES</b>																		
Flow		Adsorber Influent (COI)	CONTINUOUS															
Temperature		Adsorber Influent (COI)	CONTINUOUS															
Pressure		Adsorber Influent (COI)	CONTINUOUS															
VOCs	TO-14A	Adsorber Influent (COI)	1	1	1	1	1	1	1	1	1	1	1	1	1	1	1	1
		Adsorber Effluent (COE)	1	1	1	1	1	1	1	1	1	1	1	1	1	1	1	1
Semi-VOCs	TO-13	Scrubber Effluent (CSE)	1	1	1	1	1	1	1	1	1	1	1	1	1	1	1	1
		Adsorber Influent (COI)	1	1	1	1	1	1	1	1	1	1	1	1	1	1	1	1
NMOCs	TO-12	Adsorber Effluent (COE)	1	1	1	1	1	1	1	1	1	1	1	1	1	1	1	1
		Adsorber Influent (COI)	1	1	1	1	1	1	1	1	1	1	1	1	1	1	1	1
NO <sub>2</sub> , O <sub>3</sub> , CO	Carb 100	Scrubber Effluent (CSE)	1	1	1	1	1	1	1	1	1	1	1	1	1	1	1	1
		Adsorber Influent (COI)	1	1	1	1	1	1	1	1	1	1	1	1	1	1	1	1
Cl, HC, HF	EPA 26A	Scrubber Effluent (CSE)	1	1	1	1	1	1	1	1	1	1	1	1	1	1	1	1
		Adsorber Influent (COI)	1	1	1	1	1	1	1	1	1	1	1	1	1	1	1	1
Phosgene	EPA TO-6	Scrubber Effluent (CSE)	1	1	1	1	1	1	1	1	1	1	1	1	1	1	1	1
		Adsorber Influent (COI)	1	1	1	1	1	1	1	1	1	1	1	1	1	1	1	1
Ozone	NIOSH S8	Scrubber Effluent (CSE)	1	1	1	1	1	1	1	1	1	1	1	1	1	1	1	1
		Adsorber Influent (COI)	1	1	1	1	1	1	1	1	1	1	1	1	1	1	1	1
Total VOCs	PID	Adsorber Influent (COI)	H O U R L Y															
		Adsorber Effluent (COE)	H O U R L Y															
		Scrubber Effluent (CSE)	H O U R L Y															
<b>MEDIA SAMPLES</b>																		
VOCs	EPA 8260A	Scrubber Liquid (CSL)																1
		Carbon (GAC)																
Semi-VOCs	EPA 8270B	QC Sample																1
		Scrubber Liquid (CSL)																
TPH	EPA 5090,3550/6015 mod	Carbon (GAC)																1
		Scrubber Liquid (CSL)																
pH	EPA 9040	Carbon (GAC)																1
		Scrubber Liquid (CSL)																

**NOTES:**

VOCs  
 NMOCs  
 NO<sub>2</sub>, O<sub>3</sub>, CO  
 TPH  
 TB  
 CL, HCl, HF

VOLATILE ORGANIC COMPOUNDS  
 NON-METHANE ORGANIC COMPOUNDS  
 NITROGEN DIOXIDE, OXYGEN AND CARBON MONOXIDE  
 TOTAL PETROLEUM HYDROCARBONS  
 A FIELD DUPLICATE WILL ALSO BE COLLECTED AT THIS LOCATION  
 TRIP BLANKS WILL BE SUBMITTED ALONG WITH THE LIQUID SAMPLES ONLY AND ANALYZED FOR VOCs (EPA METHOD 8260A)  
 CHLORINE, HYDROCHLORIC ACID, HYDROFLUORIC ACID

McCLELLAN AIR FORCE BASE MICROWAVE REGENERATED GAC TEST	TABLE <b>5-1</b>
SAMPLING SCHEDULE	JOB NO: 024229
<b>M&amp;E</b> McConnell & Eddy Inc.	DATE: SEPT. 1998

1 During each inspection, the field technician will also monitor and record hours of operation,  
2 electrical usage, and pH of the scrubber solution. Hours of operation will be recorded  
3 by a built-in hour meter in the extraction system control box. Amperage readings will be  
4 collected using an analog, rotary-scale ammeter. Electrical usage will then be calculated by  
5 multiplying the amperage by the known voltage use and hours of operation. The pH of the  
6 scrubber solution will be monitored and recorded daily using on-site pH monitoring  
7 equipment. The scrubber solution will be supplemented with fresh NaOH as needed to  
8 maintain a pH range between 9 and 12. The spent scrubber solution (NaOH) will remain  
9 onsite in a 55-gallon drum and analyzed at the end of the test. A total of 40-gallons of  
10 spent scrubber solution is anticipated to be generated over the test duration. M&E will be  
11 responsible to characterize the waste for profiling purposes. It is M&E's understanding that  
12 McClellan AFB personnel will be responsible for all waste disposal generated during the  
13 test.

14 In the event of system shut down, an M&E field technician will record the cause. If the  
15 shutdown is microwave regenerated GAC-related, the technician will perform the necessary  
16 repairs and adjustments. In the event that the shut down is related to the existing SVE system,  
17 M&E will notify the McClellan AFB field project manager.

## 18 5.4 MATERIAL STORAGE

---

19 Approximately 100 lbs of NaOH pellets (packaged in bags) and miscellaneous health and  
20 safety equipment will be stored on site. A 5 percent (%) NaOH solution will be prepared  
21 by combining NaOH pellets and water and be stored in a 5 gallon Nalgene® carboy. No  
22 more than 20 gallons of NaOH solution will be stored on-site at one time. The sodium hydroxide  
23 solution will be used to supplement the existing scrubber. Water from the air-water  
24 separator will also be collected and stored on-site in a 55-gallon drum. No other materials  
25 are anticipated.

*GAC Regen condensate?  
Bag house?*

## 26 5.5 RESIDUALS MANAGEMENT

---

27 This section provides a waste management plan for the microwave regenerated GAC test.  
28 M&E does not anticipate generating any hazardous waste as a result of the test activities;  
29 however, the following waste streams will be characterized to facilitate proper handling and  
30 disposal.

### 31 5.5.1 LIQUID PHASE PRODUCT (SCRUBBER SOLUTION)

32 Spent scrubber solution will be collected in a DOT-approved 55-gallon drum housed inside  
33 the temporary structure when the pH of the solution is less than 9. Silicon® tubing will be

1 connected to the outlet valve and the spent scrubber solution will be drained into a 5 gallon  
2 Nalgene® carboy. The field test operator will then carefully transfer the solution from the  
3 carboy to a labeled 55-gallon drum for storage.

#### 4 5.5.2 REGENERATED GAC

5 The GAC for the project will be continuously recycled with the test unit. No wastes are  
6 expected.

*Cyclone? emptying / cleaning procedures?*

#### 7 5.5.3 DECONTAMINATION RINSEATE

8 Once the test is complete, the distribution piping associated with the microwave regener-  
9 ated GAC system will be removed and rinsed. The rinseate will be collected into a DOT-  
10 approved 55-gallon drum and housed inside the temporary structure. The rinseate drum  
11 will be labeled at all times indicating its content.

#### 12 5.5.4 DEMOBILIZATION AND SITE RESTORATION PROCEDURES

13 Upon completion of the test, M&E will remove the microwave regenerated GAC test unit  
14 and utility connections used for the test. The temporary shed will also be removed.

15 Since no intrusive work is required during installation of the test unit, no adverse impacts  
16 are expected in the surrounding environment. Prior to leaving the site, McClellan AFB  
17 field personnel will inspect the site. M&E will remedy any deficiencies noted during this  
18 inspection.

# 6.0 PERMITTING & REGULATORY COMPLIANCE

## 6.1 PERMITTING

---

McClellan AFB is providing accommodations at OU D Site S that allow for operation of the microwave regenerated GAC test unit. This WIP will provide the basis for McClellan AFB to obtain necessary utility clearances and permits for the microwave regenerated GAC test unit installation and operation.

It is M&E's understanding that no permit is required from the SMAQMD for this test. Air emissions permitting is not required because the test will be conducted on a slipstream without separate discharge. The existing treatment system at OU D Site S currently operates in compliance with SMAQMD requirements and will treat the microwave regenerated GAC emissions.

Section 4 of the Performance Work Statement (PWS) provided by McClellan AFB with the contract award establishes safety and waste management specifications that will serve as permit requirements for the microwave regenerated GAC test operations.

## 6.2 REGULATORY COMPLIANCE

---

As stated above, no permit is required from the SMAQMD for this test nor is one required for CERCLA remediation systems at McClellan AFB. However, the following regulations apply to the microwave regenerated GAC demonstration.

### 6.2.1 COMPLIANCE WITH EMISSION REDUCTION CREDIT ALLOCATION

McClellan AFB has allocated emission reduction credits (ERCs) for reactive organic compounds and NO<sub>x</sub> emissions for OU D Site S operations. The emission levels to date have been within the allocated levels (URSG, 1998a). No significant increase in emissions are anticipated as a result of the demonstration operations.

### 6.2.2 DIOXIN/FURAN EMISSIONS

In May 1993, the EPA issued a draft strategy for combustion of hazardous waste. In the document, EPA recommends that states impose, as an interim measure, a dioxin/furan

---

1 tended for hazardous waste combustion facilities, and therefore is not directly applicable to  
2 the demonstration system.

3 **6.2.3 HEALTH AND SAFETY REQUIREMENTS**

4 Health and safety requirements are detailed in the site-specific health and safety plan pro-  
5 vided as Appendix A.

# 7.0

# SAMPLING PLAN

1 The following section summarizes the sampling objectives; rationale, field methods, and  
2 quality control procedures associated with each phase of the microwave regenerated  
3 GAC test. Sampling parameters, frequencies, and test methods are summarized in  
4 Table 5-1. Sample container types and holding times are summarized in Table 7-1.  
5 Field instrumentation and equipment component specifications are summarized in  
6 Table 7-2.

## 7 7.1 SYSTEM STARTUP AND OPTIMIZATION SAMPLING

---

8 Following installation of the microwave regenerated GAC test unit, monitoring will be  
9 conducted to obtain and maintain effective system performance. The startup and opti-  
10 mization phase of the project is expected to last 5 days. The objectives of the system startup  
11 and optimization sampling are to:

- 12 • Obtain instantaneous screening level data to observe and adjust system  
13 performance.
- 14 • Document influent and effluent process system concentrations at the start of the  
15 test.

16 Field procedures during startup will include three activities: system parameter monitoring,  
17 VOC screening and sample collection and analysis. System parameter monitoring will  
18 include monitoring of pressure, flow, and temperature and noting them on the field log.  
19 Temperature, flow, and pressure measurements will be collected and recorded using the  
20 on-site DAS. The proposed locations of the temperature, pressure, and flow measurement  
21 collection locations are shown on Figure 3-1.

22 During system startup, VOC screening will be measured in the field using Thermo  
23 Environmental Instruments, Inc.'s organic vapor monitor (OVM) Model 580B equipped  
24 with a 10.6 electron-volt ultraviolet lamp. The PID will be calibrated on a daily basis in  
25 accordance with the Basewide QAPP (SOP No. McAFB-020). VOC screening will be  
26 performed hourly at each vapor-sample port (COI, COE, and CSE) shown on Figure 3-1  
27 and in accordance with the Basewide QAPP (SOP No. McAFB-020).

28 On the fifth day of startup and optimization, M&E will collect vapor samples from sample  
29 ports COI, COE, and CSE for analysis of VOCs, NMOCs, Semi-VOCs, and diox-  
30 ins/furans. VOCs and NMOCs will be collected using laboratory-supplied SUMMA®  
31 canisters and will be submitted to a California-certified laboratory under appropriate chain-  
32 of-custody and analyzed for TO-14A and TO-12, respectively. Vapor sample collection of  
33 VOCs and NMOCs will be performed in accordance with the Basewide Soil Vapor

1 Extraction Removal Action Work Plan (SVE RAWP) (TSOP No. SVE-001). A variable  
 2 rate flow controller will be used for sample collection in accordance with the Basewide  
 3 QAPP (SOP McAFB-033).

**TABLE 7-1**

**SAMPLE CONTAINERS AND HOLDING TIMES**

Parameter	Analytical Method	Sample Container	Holding Time	Preservation
<b>Vapor Samples</b>				
VOCs	TO-14A	SUMMA® Canisters	14 Days	None
Semi-VOCs	TO-13	PUF/XAD® Resin	7 Days	None
NMOCs	TO-12	SUMMA® Canisters	14 Days	None
NO <sub>2</sub> , O <sub>2</sub> , CO	CARB 100	Continuous Monitor	N/A	None
Cl, HCl, HF	EPA 26A	Continuous Monitor	N/A	None
Phosgene	EPA TO-6	Continuous Monitor	N/A	None
Ozone	NIOSH S8	Continuous Monitor	N/A	None
Dioxins & Furans	EPA 23	PUF/XAD® Resin	30 Days*	None
<b>Liquid Samples</b>				
VOCs	EPA 8260A	40-mil VOA(3)	14 Days	HCl to pH ≤2 /Cool to 4°C
Semi-VOCs	EPA 8270B	Amber Liter(2)	7 Days	Cool to 4°C
TPH	EPA 5030, 3550/8015 mod	Amber Liter(2)	28 Days	HCl to pH ≤2 /Cool to 4°C
pH	EPA 9040	Poly 0.5 Liter(2)	24 Hours	None
<b>GAC Samples</b>				
VOCs	EPA 8260A	8-oz. Glass Jar(2)	14 Days	Cool to 4°C
Semi-VOCs	EPA 8270B	8-oz. Glass Jar(2)	7 Days	Cool to 4°C
TPH	EPA 5030, 3550/8015 mod	8-oz. Glass Jar(2)	28 Days	Cool to 4°C

\* 30 days until extraction, 45 days from extraction to analysis

**TABLE 7-2****FIELD INSTRUMENTATION AND EQUIPMENT SPECIFICATIONS**

<b>Equipment</b>	<b>Manufacturer</b>	<b>Model Number</b>	<b>Range</b>
PID Meter	Thermo Environmental Instruments, Inc.	580B OVM	0-2,000 ppmv
pH	Hanna <sup>®</sup> Instruments, Micro-computer pH meter	9025	0-14
Pressure Sensor	Rosemont <sup>®</sup> Digital, LCD Readout (4 to 20 mA range)	3051	0-250 inches of H <sub>2</sub> O
Air Flow Meter	Rosemont <sup>®</sup> Smart-Vortex	8800	0-150 scfm
Temperature Thermocouple	Omega <sup>®</sup> , Type J, Shielded with SS jacket	JQIN-18-12	32-1382°F
Data Acquisition System	Camile <sup>®</sup> , complete with Compaq <sup>®</sup> 386/25 PC	2000	64 channels Analog, 64 channels Digital
Air Cooler	Hankison <sup>®</sup> refrigerated air dryer, Refrigerant is F134A	PR 25	N/A
Extraction Blower	Spencer-Turbine <sup>®</sup> , 3 HP, 3 phase, 230V, 10.5A	VB-030-E Vortex	3 HP

Semi-VOCs and dioxins/furans will be collected using laboratory-supplied PUF/XAD<sup>®</sup> resin cartridges and will be submitted to the certified laboratory under appropriate chain-of-custody and analyzed for TO-13 and EPA 23, respectively. The resin cartridges will be connected to the vapor sample ports similar to the SUMMA<sup>®</sup> canisters. Once attached, the control valve will be opened and the vapor will be allowed to flow through the resin canister. A minimum of 20 liters of vapor will be allowed to flow through the resin canister.

As part of the startup and optimization, a total of four vapor samples are scheduled to be submitted to an off-site state-certified laboratory. Vapor samples will be collected and analyzed for dioxins/furans only during the startup phase of the test.

## 7.2 TEST PHASE

Following system startup and optimization, the microwave regenerated GAC test phase will be implemented. Monitoring during the test phase will be conducted to assess system parameters. The duration of the test phase is scheduled for eleven weeks. The specific

1 objective of the test phase is to demonstrate the efficiency of the microwave regenerated  
2 GAC system to process the SVE air stream at OU D Site S.

3 Field activities during the test phase will also include system parameter monitoring, VOC  
4 screening and sample collection and analysis. Although the sampling procedures will be  
5 the same as described in the system startup and optimization section (section 7.1), the fre-  
6 quency will be different. Sample collection and analysis will be performed during this  
7 phase in accordance with Table 5-1. System parameter monitoring will continue to be per-  
8 formed and recorded on 5-minute intervals using the DAS. VOC screening will be per-  
9 formed once daily. During the test phase, vapor sampling and analysis at each vapor  
10 sample port will be conducted weekly. Influent and effluent vapor samples will be  
11 collected simultaneously by field test personnel.

12 As a quality assurance check, 10 percent of all test samples collected will be duplicated and  
13 analyzed by a separate independent and state-certified laboratory for the same constituents  
14 as the primary samples. Duplicate samples will be collected in accordance with the Base-  
15 wide SVE RAWP (TSOP No. SVE-001). Duplicate sample collection frequency is  
16 presented in Table 5-1. The results of the duplicate samples will be included with the  
17 results report.

### 18 7.3 ASSESSMENT OF UNDESIRABLE BYPRODUCTS

19 During the fourth week of the test phase, sampling will be conducted to demonstrate that  
20 the microwave regenerated GAC system does not generate undesirable byproduct  
21 emissions. If detected, the quantities will be compared with McClellan AFB cumulative  
22 limits and the amounts that would be anticipated from comparable technologies.

23 The source test will be conducted onsite in a mobile laboratory. During the one-day source  
24 emissions test, samples will be collected from the scrubber effluent port (CSE, Figure 3-1)  
25 and analyzed by a state-certified laboratory for the following:

26 NO<sub>2</sub>, O<sub>2</sub>, CO – CARB 100

27 Cl, HCl, HF – EPA 26A

28 Phosgene – EPA T0-6

29 Ozone – NIOSH S8

30 Emission control samples will be collected following the procedures outlined in each of  
31 their respective methods. Laboratory analysis procedures, sample collection procedures,  
32 and analytical acceptance criteria for the above-mentioned test methods are included in  
33 Appendix B. The results of this testing will be presented in the results report.

---

## 1      7.4      POST-TEST SAMPLING

---

2      At the end of the test, sampling will be conducted to assess residual contaminant concen-  
3      trations in the process media. The objectives of the post test samples are to:

- 4            •    quantify residual contaminant mass for use in the mass balance calculations.
- 5            •    characterize the residual process media to facilitate appropriate disposal.

6      Post-test sampling will include the collection of one spent scrubber solution sample and the  
7      collection of one final regenerated GAC sample. The spent scrubber solution sample will  
8      be collected using a disposable polyethylene colliwasa. Once collected, the liquid samples  
9      will be placed into laboratory-supplied vials and one-liter amber bottles for transport to a  
10     state-certified laboratory. Sample analysis will include VOCs (EPA Method 8260A),  
11     semi-VOCs (EPA Method 8270B), total petroleum hydrocarbons (EPA 3550, 5030/8015  
12     mod), and pH (EPA 9040).

13     Following the last GAC regeneration, one GAC sample will be collected from the adsorber  
14     and placed into an 8-ounce glass jar for shipment to a state-certified laboratory. The GAC  
15     sample will be analyzed for the same constituents as the spent scrubber solution detailed  
16     above. Given the thorough mixing of GAC as a result of approximately 15 regenerations  
17     through the desorber, the sample collected will be considered representative of the entire  
18     GAC vessel. No quality control samples are scheduled for the post-test samples. The  
19     results of the post-test sampling will be included in the results report.

20     The liquid generated by the air-water separator will be managed and disposed of by  
21     McClellan AFB personnel.

## 22     7.5      SAMPLE CUSTODY AND DOCUMENTATION

---

23     An integral part of environmental sampling is sample custody and documentation. After  
24     samples have been collected and labeled, they will be maintained under chain of custody  
25     procedures. These procedures document the transfer to custody for samples from the field  
26     to a designated laboratory. A chain of custody record will be filled out for each shipment  
27     of samples to be sent to a laboratory for analysis. Information contained on the triplicate  
28     carbonless forms will include the following:

- 29            •    Sample identification number (as specified in Section 7.6) and number of  
30                    sample containers.
- 31            •    Date and time the sample was taken.
- 32            •    Analyses requested.

- 1           • Remarks including preservatives added and any special conditions or specific  
2           quality control measures.

3 After carefully packaging the samples into an ice chest (a chilled ice chest for liquid and  
4 solid samples) for transfer to the laboratory, the field sampler will sign the chain of custody  
5 record and record the time and date of relinquishment. Concurrently, the receiver (i.e.,  
6 courier of laboratory) will sign and date the chain of custody record at time of receipt. A  
7 duplicate copy will be retained with the project files at time of custody transfer. The origi-  
8 nal imprint of the chain of custody record will accompany the samples. Additional sample  
9 custody and documentation information is provided in Section 8.7.

## 10    7.6    FIELD SAMPLE IDENTIFICATION

---

11 The sample identification scheme proposed for the microwave regenerated GAC demon-  
12 stration is as follows:

<u>Sample Location</u>	<u>Identification</u>
Adsorber Influent	COI
Adsorber Effluent	COE
Caustic Scrubber Effluent	CSE
Caustic Scrubber Liquid	CSL
Granular Activated Carbon	GAC

13 For example, a vapor sample collected during the first week of operation at the sample port  
14 on the adsorber influent would be labeled as COI-1. A vapor sample collected from the  
15 sample port on the caustic scrubber liquid during the second week of operation would be  
16 labeled as CSE-2. This same sample identification will be followed for liquid and solid  
17 samples.

# 8.0 QUALITY ASSURANCE PROJECT PLAN

## 1 8.1 INTRODUCTION AND OBJECTIVES

---

2 This section presents the Quality Assurance Project Plan (QAPP) for the microwave regen-  
3 erated GAC test demonstration. This QAPP specifies the procedures the demonstration will  
4 follow to ensure it generates analytical data of known quality. These procedures are inte-  
5 gral to the demonstration and complement the sampling plan presented in Section 7. The  
6 specific objectives of this QAPP are to establish the necessary procedures, organization,  
7 and specific quality assurance/quality control (QA/QC) goals to meet the overall project  
8 objectives presented in Section 4.3. The Final Basewide RI/FS QAPP will provide the ba-  
9 sis for QA/QC protocol during the microwave regenerated GAC test.

## 10 8.2 MEASUREMENTS

---

11 Measurements described in this QAPP will be used to determine the effectiveness of the  
12 microwave regenerated GAC test unit. The collection of both screening level and defini-  
13 tive analytical data is proposed to meet the objectives of the test. Field instrument meas-  
14 urements will be considered definitive for flow rate, temperature, and pressure based on the  
15 manufacturer's calibration. The Rosemont<sup>®</sup> air flow meter has built in corrections for tem-  
16 perature. Measured airflow rates will be periodically compared with available pump curve  
17 data (pressure vs. flow) provided by the blower manufacturer to ensure accurate readings.  
18 Chemical analyses performed by state-certified laboratories will also be considered defini-  
19 tive. Field instrument measurements for VOCs will be considered as screening level data.

## 20 8.3 KEY PERSONNEL

---

21 The project organization for the microwave regenerated GAC test is shown on Figure 8-1.  
22 Key personnel include the following staff members:

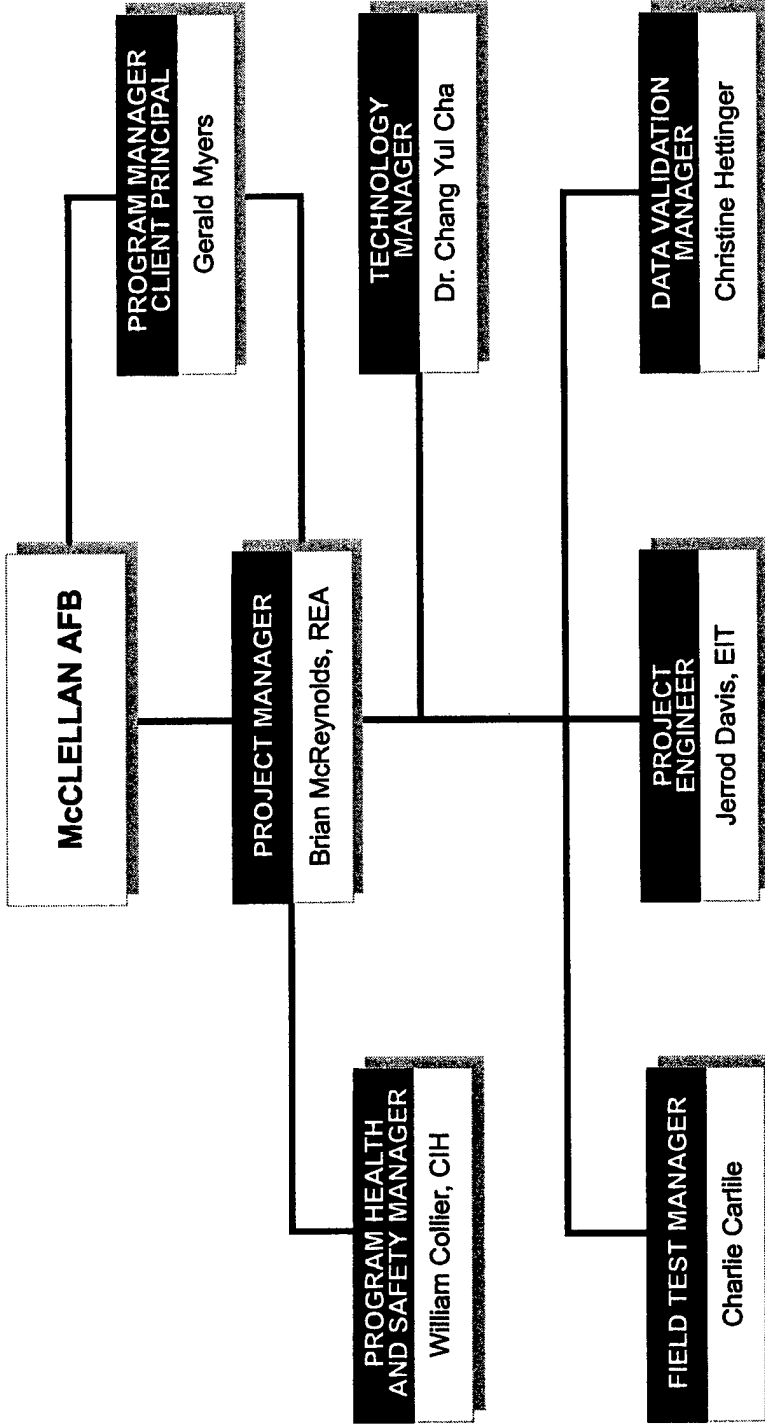

McCLELLAN AIR FORCE BASE MICROWAVE REGENERATED GAC TEST	FIGURE <b>8-1</b>	
PROJECT ORGANIZATION CHART	JOB NO: 024229	DATE: SEPT. 1998

**TABLE 8-1****KEY PROJECT PERSONNEL AND TELEPHONE NUMBERS**

<b>Staff Member</b>	<b>Telephone Number</b>	<b>Affiliation</b>	<b>Alternate Phone No.</b>
Program Manager (Gerald Myers)	(916) 567-4200	M&E	(800) 729-3144
Project Manager (Brian McReynolds, REA)	(916) 567-4200	M&E	(530) 342-6958
Project Engineer (Jerrod Davis, EIT)	(916) 567-4200	M&E	(530) 342-6958
Technology Specialist (Dr. Chang Yul Cha)	(307) 742-2829	CHA Corp.	N/A
Field Test Manager (Charlie Carlisle)	(307) 742-2829	CHA Corp.	N/A
Program Health and Safety Officer (William Collier, CIH)	(916) 567-4200	M&E	N/A
Data Validation Manager (Christine Hettinger)	(404) 881-8010	M&E	N/A

The following sections describe the responsibilities of the key personnel listed above.

**8.3.1 PROGRAM MANAGER**

The Program Manager (Mr. Gerald Myers) is the corporate officer responsible for the overall METRIC contract with McClellan AFB. The Program Manager will be responsible for making sure that the overall program meets its objectives and contractual requirements. He will also participate in meetings with McClellan AFB and review the status of the project on a monthly basis.

**8.3.2 PROJECT MANAGER**

The M&E Project Manager (Mr. Brian McReynolds) has overall Quality Assurance responsibility and authority for project coordination between McClellan AFB and M&E. The Project Manager (PM) will be responsible for the development and approval of all documents, including the WIP, and Final Report. Specific duties of the PM will consist of:

- providing senior level input and expertise throughout the entire microwave regenerated GAC test.
- providing guidance and direction to project staff.
- monitoring the progress of work with respect to schedules and budget.
- identifying anticipated quality concerns and provide resolutions.

1 **8.3.3 PROJECT ENGINEER**

2 The M&E Project Engineer (Mr. Jerrod Davis) will report directly to the PM and is respon-  
3 sible for the development and implementation of all delivery-order documents and activi-  
4 ties. The specific responsibilities of the Project Engineer (PE) consists of:

- 5 • preparing delivery order documents.
- 6 • making sure that appropriate sampling, testing, and analysis procedures are  
7 followed throughout the project.
- 8 • monitoring subcontractors and analytical laboratories for compliance with data  
9 quality requirements.
- 10 • coordinating field activities.
- 11 • reporting QA problems to the McClellan Field Project Manager and M&E's PM.

12 **8.3.4 TECHNOLOGY SPECIALIST**

13 The Technology Specialist for this test is Dr. Chang Yul Cha who is the president of the  
14 CHA Corporation and the founder of the microwave regenerated GAC technology. Dr.  
15 Cha will be responsible for providing technical oversight and direction throughout the test.

16 **8.3.5 FIELD TEST MANAGER**

17 The Field Test Manager for the microwave regenerated GAC test will be Mr. Charlie Car-  
18 lile with the CHA Cooperation. This position reports directly to the M&E PM. The specific  
19 responsibilities of the Field Test Manager (FTM) consists of:

- 20 • providing coordination between the field technicians.
- 21 • implementing the WIP.
- 22 • collectings and recording daily process measurements and PID readings;
- 23 • supervising sample collection and sample logging.
- 24 • coordinating the transfer of field data to the M&E PM.

25 **8.3.6 PROGRAM HEALTH AND SAFETY OFFICER**

26 The M&E Program Health and Safety Officer (Mr. William Collier, CIH) will be responsi-  
27 ble for site safety and health and ensuring that the safety and health plan is implemented.  
28 The specific duties of the Program Health and Safety Officer (HASO) consists of:

- 1 • supervising field personnel to make sure that the Health and Safety Plan is being  
2 followed.
- 3 • making sure that all field personnel and subcontractors are familiar with the Health  
4 and Safety Plan and meet training and medical requirements.

### 5 8.3.7 M&E DATA VALIDATION MANAGER

6 The M&E Data Validation Manager (DVM) for this test (Ms. Christine Hettinger) operates  
7 independently of the PM and will be responsible for the development of the QAPP docu-  
8 ment and coordination of sample analysis with the laboratory. The specific responsibilities  
9 of the DVM are to:

- 10 • serve as the primary contact with the laboratory.
- 11 • review laboratory reports and ensure that all the QA/QC requirements have been  
12 met.
- 13 • manage IRPIMS deliverables as necessary.
- 14 • Inspect work activities and project deliverables to make sure that quality control  
15 activities are not compromised.

### 16 8.3.8 LABORATORY MANAGER

17 The Laboratory Manager (LM) for this test will be a representative from Air Toxics, Ltd.  
18 The LM will be responsible for checking laboratory quality against the requirements of the  
19 McClellan Basewide QAPP. This work shall occur before laboratory reports are trans-  
20 ferred to M&E.

## 21 8.4 QUALITY ASSURANCE OBJECTIVES

---

22 The overall objectives of the microwave regenerated GAC test are to provide data of suffi-  
23 cient quality to properly evaluate the following:

- 24 • demonstrate the performance and efficiency of the GAC system to process a SVE  
25 or air stripper off-gas stream of VOCs as well as other co-contaminants using  
26 microwave regeneration of the GAC media.
- 27 • quantify cost data for the technology under field conditions encountered at  
28 McClellan AFB.

- 1 • determine the expected useful life of GAC that will be regenerated using  
2 microwave energy.
- 3 • verify that the performance of the treatment system meets BACT standards set forth  
4 by regulatory agencies.

5 Each of these broad objectives is described in terms of specific measurable quantities in  
6 Section 4.6.

7 The specific analytical objectives of the microwave regenerated GAC demonstration are to  
8 produce well-documented data of known quality. To this end, individual analytical meas-  
9 urements are to meet particular QA objectives. These objectives include precision, accu-  
10 racy, method detection limits, completeness, comparability and representativeness. The  
11 specific analytical control acceptance criteria for the microwave regenerated GAC test are  
12 presented in Table 8-2. The analytical data quality measurements are discussed further in  
13 the sections that follow:

#### 14 8.4.1 PRECISION

15 Precision is a measure of agreement among individual measurements of the same property  
16 under similar conditions. Precision is expressed in terms of relative percent difference  
17 (RPD) between duplicates or in terms of the standard deviation when three or more repli-  
18 cate analyses are performed.

19 Precision will be determined through the use of matrix spike/matrix spike duplicate  
20 (MS/MSD) analyses. The RPD between the two results will be calculated as a measure of  
21 analytical precision.

22 The precision is defined as the RPD of the two replicate determinations of the same matrix  
23 spike or field duplicate samples:

$$24 \text{ RPD} = 2 \times [(D_1 - D_2) / (D_1 + D_2)] \times 100$$

25 Where:

26  $D_1$  = first determination

27  $D_2$  = second determination

28

1  
2  
3

**TABLE 8-2**

**QUALITY CONTROL ACCEPTANCE CRITERIA**

<b>Analysis</b>	<b>Reference Method</b>	<b>Applicable Quality Control Acceptance Criteria</b>
<b>Vapors and Emissions</b>		
VOCs	EPA TO-14A	Basewide QAPP (Tables 4-2, 8-13, and 10-27)
Semi-VOCs	EPA-TO-12	Basewide QAPP (Tables 4-2 and 10-30)
NMOCs	EPA TO-13	(EPA TO-13, Appendix B)
NO <sub>2</sub> , O <sub>2</sub> , CO	CARB-100	N/A
Cl, HCl, HF	EPA 26A	(EPA 26A, Appendix B)
Phosgene	EPA T0-6	(EPA TO-6, Appendix B)
Ozone	NIOSH S8	(NIOSH S8, Appendix B)
Dioxins & Furans	EPA 23	Basewide SVE RAWP (Tables 6-1 and 6-8)
<b>Liquid</b>		
VOCs	EPA 8260A	Basewide QAPP (Tables 4-11a, 8-9, and 10-11)
Semi-VOCs	EPA 8270B	Basewide QAPP (Tables 4-12, 8-10, and 10-12)
TPH	EPA 5030, 3550/8015 Mod	Basewide QAPP (Tables 4-6, 8-5, and 10-6, & Tables 4-7, 8-5, and 10-7)
pH	EPA 9040	N/A
<b>GAC</b>		
VOCs	EPA 8260A	Basewide QAPP (Tables 4-11a, 8-9, and 10-11)
Semi-VOCs	EPA 8270B	Basewide QAPP (Tables 4-12, 8-10, and 10-12)
TPH	EPA 5030, 3550/8015 Mod	Basewide QAPP (Tables 4-6, 8-5, and 10-6, & Tables 4-7, 8-5, and 10-7)

1    **8.4.2    ACCURACY**

2    Accuracy is defined as the degree of agreement of a measurement (or measurement aver-  
3    age) with an accepted reference or true value. It is a measure of system bias and is usually  
4    expressed as a percentage of the true value.

5    Accuracy will be determined in the laboratory through the use of MS/MDS analyses. The  
6    percent recovery of the spike analyte(s) will give information on the accuracy of the ana-  
7    lytical method and procedures in that particular sample matrix. The laboratory for accuracy  
8    for each matrix being submitted will analyze one environmental sample in 20. Information  
9    on overall method performance will be obtained by calculating spike recoveries.

10   Laboratory accuracy will also be ensured by the analysis of method blanks. These blanks  
11   will be prepared in the laboratory in a similar fashion as the associated samples of a par-  
12   ticular matrix (i.e., soil, water, etc.) and analyzed along with these samples. The results of  
13   the analysis of the blanks are a measure of the preparation accuracy and serve as a check on  
14   any sample contamination, which may be encountered during sample preparation.

15   Sampling accuracy will be maintained by the implementation of an adherence to strict pro-  
16   cedural protocols. Trip blanks and equipment blanks will be collected and analyzed to en-  
17   sure that all samples are representative of the particular site from which they are collected  
18   and to ensure that no cross-contamination of samples has occurred.

19   To determine the accuracy of an analytical method, a periodic program of sample spiking  
20   is conducted. The results of sample spiking will be used to calculate the quality control pa-  
21   rameter for accuracy evaluation, the percent recovery (%R).

22   The %R is defined as 100 times the observed concentration, minus the sample concentra-  
23   tion, divided by the true concentration of the spike.

24                                    %R    =   {(A-B)/T} x 100

25  
26                                    Where:

- 27  
28                                    %R    =   The percent recover  
29                                    A       =   Measured concentration of the spike  
30                                    B       =   Measured sample concentration before the spike  
31                                    T       =   The true concentration of the spike

32    **8.4.3    COMPLETENESS**

33    Completeness is a measure of the amount of valid data obtained compared to the amount  
34    expected to be collected under normal correct conditions. It is usually expressed as a per-  
35    centage. The completeness criterion for the project is 90 percent.

1 Completeness is calculated as the percentage of valid data points obtained compared to the  
2 quantities of valid data that were to be collected to achieve particular project requirements.  
3 Data points may not be valid if samples exceeded holding times, if quality control sample  
4 criteria were not met and reanalysis of samples was not possible, or if sample containers  
5 were broken or otherwise destroyed.

#### 6 8.4.4 REPRESENTATIVENESS

7 Representativeness expresses the degree to which data accurately and precisely represent a  
8 characteristic of a data population, process condition, sampling point, or an environment.  
9 Representativeness is a qualitative parameter of the sampling program. Following a de-  
10 termination of procession, a statement on representativeness will be prepared noting the  
11 degree to which data represent the environment. Representativeness is also dependent on  
12 proper sample collection techniques that can be evaluated through the analysis of field du-  
13 plicate samples. Field duplicates are further discussed in Section 8.7.

#### 14 8.4.5 COMPARABILITY

15 Comparability is a qualitative parameter expressing the confidence with which one data set  
16 can be compared to another. To achieve comparability in this project, the data generated  
17 from aqueous matrices shall be reported using units of mass-to-volume such as micrograms  
18 per liter ( $\mu\text{g/L}$ ) or milligrams per liter ( $\text{mg/L}$ ). Data for solid matrices shall be reported in  
19 mass-to-mass limits such as micrograms per kilograms ( $\mu\text{g/kg}$ ) or milligrams per kilogram  
20 ( $\text{mg/kg}$ ) based on dry weight and data for vapor samples will be reported in concentrations  
21 to volume such as parts per million by volume ( $\text{ppmv}$ ). All sampling and analysis proce-  
22 dures used shall be consistent with EPA, State of California, and United States Air Force  
23 (USAF) protocols (Radian, 1997 & U.S.EPA, 1987). All analytical results collected from  
24 different sites within the base will, therefore, be comparable.

### 25 8.5 ANALYTICAL METHODS

---

26 The analytical methods proposed for the microwave regenerated GAC test include the fol-  
27 lowing:

Parameter	Methods
VOCs	EPA 8260A, TO-14A
Semi VOCs	EPA 8270B, TO-13
NMOCS	EPA TO-12

Parameter	Methods
NO <sub>2</sub> , O <sub>2</sub> , CO	CARB 100
Cl, HCl, HF	EPA 26A
Phosgene	EPA T0-6
Ozone	NIOSH S8
TPHp	EPA 5030/8015 mod
TPHe	EPA 3550/8015 Mod
Dioxins/Furans	EPA 23

1 Each of the analytical methods proposed for the microwave regenerated GAC test are stan-  
 2 dard EPA, NIOSH, or CARB methods and have specific procedures incorporated herein by  
 3 reference.

## 4 8.6 EQUIPMENT CALIBRATION AND PREVENTIVE 5 MAINTENANCE

---

6 Equipment calibration and preventive maintenance will be implemented on a scheduled ba-  
 7 sis to minimize downtime and to make sure measurements are accurate from both field and  
 8 laboratory equipment. This program is designed to achieve results commensurate with the  
 9 specified capabilities of equipment operations, thus generating data of known quality with-  
 10 out concern for misapplication. In addition, back-up equipment and critical spare parts will  
 11 be maintained in order to quickly correct equipment malfunction.

12 All equipment and instruments used to generate data will be calibrated, adjusted, and  
 13 maintained to operate within manufacturers' specifications. The PID meter (Thermo Envi-  
 14 ronmental Instruments, Inc. Model 580B) will be calibrated daily in accordance with the  
 15 Basewide QAPP (SOP No. McAFB-020). The on-site pH meter (Hanna® Model 9025)  
 16 will be calibrated daily in accordance with the Basewide QAPP (SOP No. McAFB-024).

17 Maintaining the necessary accuracy, precision, sensitivity, and traceability of the equip-  
 18 ment ensures that reliable measurements and representative samples will be obtained.  
 19 Methods and intervals of calibration and maintenance will be based on the type of equip-  
 20 ment, stability characteristics, required accuracy, intended use, and environmental factors  
 21 (such as temperature, humidity, etc.). Such an effort will be conducted by trained techni-  
 22 cians using service manuals or through service agreements with a qualified maintenance  
 23 contractor. In addition, procedures will ensure that trained personnel properly use equip-  
 24 ment.

1 As appropriate, calibration and maintenance, schedules, and records will be maintained for  
2 the equipment. Both equipment and equipment records will be located in a controlled ac-  
3 cess facility when not in use. This is done to minimize equipment damage; theft and tam-  
4 pering that may jeopardize either field or laboratory measurements and ultimately, data  
5 quality. Each instrument will be assigned a unique identification number to document and  
6 track usage, maintenance, and calibration. Equipment that is identified to be out of cali-  
7 bration or malfunctioning will be removed from operation until re-calibrated or repaired.

## 8 **8.7 SAMPLE HANDLING**

---

9 Efforts will be made to handle, store, and transport samples and supplies safely. Exposure  
10 to dust, direct sunlight, high temperature, adverse weather conditions, and possible con-  
11 tamination will be avoided. Liquid and solid samples will be placed in an ice-cooled chest  
12 immediately following collection and will be delivered by M&E personnel or a reputable  
13 carrier company to the subcontracted laboratory as soon as possible and before expiration  
14 of the maximum sample holding times. A list of sampling parameters, containers, holding  
15 times, and preservation requirements for vapor, aqueous, and solid samples that will be  
16 collected during the test are provided in Table 7-1.

17 Chain of custody procedures will also be followed during transport. Sample handling pro-  
18 cedures will be conducted in accordance with the Basewide QAPP (Section 6.0, Sample  
19 Custody and Documentation).

## 20 **8.8 DATA REDUCTION, VALIDATION, AND REPORTING**

---

21 This section describes the data reduction, validation, and reporting procedures that will be  
22 used during the microwave regenerated GAC test. The primary responsibility for imple-  
23 mentation of these procedures within the laboratory resides with the DVM and LM. The  
24 LM approves all reports before transferring the information to the M&E DVM. The M&E  
25 DVM will ensure that the laboratory data is in compliance with QAPP specifications.

26 Data processing begins with the collection of data and continues through the reduction and  
27 review processes to the final data reporting procedure. This process is outlined in the fol-  
28 lowing sections.

### 29 **8.8.1 DATA COLLECTION**

30 At the laboratory, analytical data are usually recorded in bound laboratory notebooks. Data  
31 recorded includes: a unique sample identification number, a project sample identification  
32 number, the analytical method used, the analyst's signature and date of analysis, reagent

1    8.8.4    EVALUATION OF DATA USING CONTROL CHARTS.

2    The laboratory shall apply precision and accuracy criteria to each parameter that is ana-  
3    lyzed. When analysis of a sample is completed, the quality control data will be reviewed  
4    and evaluated through the use of control charts.

5    Control charts shall be established for all major analytical parameters. A minimum of ten  
6    measurements of precision and accuracy are required before control limits can be estab-  
7    lished. Once established, control limits are updated annually and as additional precision  
8    and accuracy data become available.

9    8.8.5    LABORATORY DATA REPORTING

10   The final laboratory data report will be checked and approved by the LM. Data will be pre-  
11   sented in a tabular format whenever possible and will be in the standard laboratory report  
12   format required by Level III quality control. Reports shall contain final results uncorrected  
13   for blank contamination or spike recoveries. The number of significant figures reported  
14   must be consistent with the limits of uncertainty inherent in the analytical method; most  
15   analytical results are reported to no more than two significant figures. Data are normally  
16   reported in units commonly used for the analyses performed. For this project, concentra-  
17   tions in liquids are expressed in terms of weight per unit volume (e.g.,  $\mu\text{g/L}$ ). Concentra-  
18   tions in solid or semi-solid matrices are expressed in terms of weight per unit weight of  
19   sample (e.g.,  $\text{mg/kg}$ ) based on a dry weight basis except for metals analyses which will be  
20   reported on a wet weight basis. Data reports will consist of:

- 21        • client's name and project name/definition.
- 22        • summary report of laboratory QA/QC review.
- 23        • sample identification number.
- 24        • contractor laboratory report identification.
- 25        • date sample collected.

26   8.8.6    DATA VALIDATION

27   Once received, the M&E DVM will review the laboratory reports with respect to:

- 28        • date sample received.
- 29        • date sample extracted.
- 30        • date sample analyzed.
- 31        • methods or procedure used for analyses.

- 1 • results of associated quality control sample analysis.
- 2 • copy of the chain of custody form.
- 3 • laboratory reports and chain-of-custody records to check for errors and omissions.
- 4 • laboratory case narratives to check for anomalies and exceedances of QA/QC
- 5 requirements.
- 6 • extraction and holding times.
- 7 • method blanks, trip blanks, and equipment blanks for positive concentrations.
- 8 • surrogate compounds, their splitting levels, the reported concentrations and percent
- 9 recoveries.
- 10 • MS/MSD samples, their spiked concentrations, percent recoveries and relative
- 11 percent differences.
- 12 • laboratory control samples, their spiked concentrations, determined concentrations,
- 13 and percent recoveries.
- 14 • laboratory duplicate samples, field duplicates, and relative percent differences.

## 15 8.9 INTERNAL QUALITY CONTROL CHECKS

---

16 QC samples in both the laboratory and the field will be used internally to ensure the quality  
17 of all sample analyses. All analyses performed in support of this investigation shall use  
18 standardized laboratory procedures. The QC program uses both known and unknown (or  
19 "blind") QC samples. Laboratory QC samples includes continuing calibration verification,  
20 method/reagent blanks, matrix spike/matrix spike duplicates, and surrogate spikes. Labo-  
21 ratory QC samples and quality assurance objectives are discussed in Section 8.4. Field QC  
22 samples include: trip blanks, equipment blanks, and field duplicates. A description of the  
23 field QC samples and frequencies are presented in the following sections.

### 24 8.9.1 TRIP BLANKS

25 Trip blanks are collected for chemical analysis of volatile organics. The analytical results  
26 serve as a baseline measurement of volatile organic contamination that sample containers  
27 may be exposed to during transport and laboratory storage prior to analysis.

28 Trip blanks originate in the laboratory. They are comprised of organic-free reagent water,  
29 which is placed in sample containers by the laboratory, transported to the site location,  
30 handled along with the samples, and returned to the laboratory along with samples of water  
31 and/or soil collected for volatile organic analysis. The trip blank containers are not to be  
32 opened in the field.

1 One trip blank is included in each shipping container for volatile organics analysis (liquid  
2 only). Trip blanks are stored in the laboratory with the samples, and analyzed by the labo-  
3 ratory (for volatile organics only).

#### 4 8.9.2 FIELD DUPLICATES

5 Field duplicates are defined as two samples collected independently of each other at the  
6 same sampling location during a single sampling episode. Duplicate analysis provides sta-  
7 tistical information relating to sample variability and serves as a check on the precision of  
8 any sample collection method.

9 Ten percent of all samples submitted for laboratory analysis will be collected in duplicate  
10 in accordance with the procedures described in Section 7.1. Field duplicates will be la-  
11 beled similar to field samples so that persons performing laboratory analyses are not able  
12 to distinguish duplicates from other collected samples. Field duplicates will be recorded in  
13 the field logbooks for future reference. A laboratory other than where the primary sample  
14 was submitted will analyze Field duplicates. The precision objective between the original  
15 and field duplicate sample result for this demonstration is plus or minus 50 percent for TO-  
16 12, TO-13, and TO-14A analytes.

#### 17 8.9.3 EQUIPMENT BLANKS

18 Equipment blanks are collected to verify equipment decontamination and are used in the  
19 collection of samples when devices other than the sample bottle itself are required. The  
20 analysis of these blanks serves to verify the cleanliness of the sampling equipment and the  
21 effectiveness of the decontamination procedure. No equipment blanks are scheduled for  
22 this test.

### 23 8.10 PERFORMANCE AND SYSTEM AUDITS

---

24 This section describes the QA audits that will monitor the system used to obtain measure-  
25 ments.

#### 26 8.10.1 PERFORMANCE AUDITS

27 All data generated are reviewed on four levels by the laboratory. The analyst performs the  
28 first level review, the team leader or department head has second level review, and the  
29 laboratory project manager performs a third level review. A fourth level review is per-  
30 formed through a signature review.

1 Laboratory performance audits are conducted by the laboratory manager, and include in-  
2 spection of all logbooks, records, and graphs to ensure all documentation is correct, com-  
3 plete, and up to date. Additionally, equipment and apparatus are checked to ensure they  
4 are properly maintained, while corrective actions are taken for any deficiencies noted dur-  
5 ing the audit. Laboratory performance is also audited through the State of California labo-  
6 ratory certification process. The laboratory will perform performance audits on a quarterly  
7 basis.

## 8 8.10.2 SYSTEM AUDITS

9 A system audit is an in-house, qualitative review of the various aspects of a total sampling  
10 and/or analytical system and is an assessment of overall effectiveness. One system audit  
11 will be performed by the laboratory, which may be carried out at any stage of the analytical  
12 process.

13 The laboratory manager will review:

- 14 • calibration procedures and documentation.
- 15 • completeness of data forms, notebooks, and other reporting requirements.
- 16 • data review and validation procedures.
- 17 • data storage, filing, and record keeping procedures.
- 18 • sample custody procedures.
- 19 • quality control procedures and documentation.
- 20 • operating conditions of facilities and equipment.
- 21 • documentation of maintenance activities.
- 22 • systems and operating overview.
- 23 • analytical preparation methods.

24 The laboratory will perform system audits on an annual basis.

## 25 8.11 CORRECTIVE ACTION

---

### 26 8.11.1 LABORATORY ACTIVITIES

27 The analysts directly involved with the analysis of the samples often initiate corrective ac-  
28 tion procedures in the laboratory. The laboratory analyst shall verify that all quality control

1 procedures are followed and that the results of the analysis of quality control samples are  
2 within the acceptance criteria. This requires that the analyst assess the correctness of:

- 3 • sample preparation procedure.
- 4 • initial calibration.
- 5 • calibration verification.
- 6 • method blank result.
- 7 • spiked sample result.

8 If the assessment reveals that any of the QC acceptance criteria have not been met, the  
9 analyst must immediately assess the analytical system to locate and correct the problem.  
10 The analyst notifies the appropriate supervisor and LM of the problem and, if possible,  
11 identifies potential causes and corrective action. In turn, the LM shall notify M&E if the  
12 quality of data deliverables has been compromised or if the laboratory has determined that  
13 the problem is field related.

14 The nature of the corrective action depends on the nature of the problem. For example, if  
15 continuing calibration verification is determined to be out of control, the corrective action  
16 may require recalibration of the analytical system and reanalysis of all the samples ana-  
17 lyzed since the last acceptable continuing calibration standard was run.

18 When the appropriate corrective action measures have been defined and the analytical sys-  
19 tem is determined to be "in control", the analyst documents the problem and the corrective  
20 action. Table 8-3 presents a summary of typical corrective actions used in the laboratory.

21 Data generated with an out-of control system shall be evaluated for usefulness in the light  
22 of the nature of the deficiency. If the deficiency does not impair the usefulness of the re-  
23 sults, data are reported and the deficiency is noted. Where sample results are impaired, the  
24 laboratory project manager is notified and appropriate corrective action (e.g., reanalysis) is  
25 taken.

26 Routine corrective action shall take place as necessary and does not require the approval of  
27 the LM. However, should significant events occur such as sample breakage or loss, ex-  
28 ceeding sample holding times, extensive instrumentation downtime, or changes and addi-  
29 tions to sample clean-up for removal of interferences, the laboratory shall report these  
30 events to M&E immediately.

31 Corrective actions are also initiated as a result of other project QA activities including per-  
32 formance audits, systems audits, and laboratory comparison studies.

1

2

3

# TABLE 8-3

## LABORATORY CORRECTIVE ACTIONS

Correc- tive Ac- tion Level	Condition	Personnel In- volved	Probable Cause	Resolution
Primary	Daily calibration is out of control	Bench Chemist	Instrument calibration	Recalibrate and proceed
	Retention time shift		Leak, improper temperature, etc.	Fix and proceed
	Other instrument malfunction		Change in sensitivity (defective lamp or detector)	Fix and proceed
Secondary	QC samples out of control	Bench Chemist	Preparation procedure	Re-extract or re-digest all affected samples and proceed
		Supervisor and/or Manager	Standards Mix	Prepare new standards and proceed
		QA Officer	Spike Mix	Prepare new spike mix; re-extract or re-digest all affected samples and proceed
			Reagents	Change reagents: re-extract or re-digest all affected samples and proceed
Tertiary	Methods not followed	Bench Chemist	Persistent problems or unidentifiable cause	Retrain Chemist
	Holding times not met	Supervisor		
	QC spike frequency too low	Manager		
		QA Officer		
		Lab President (if needed)		
	Corporate Vice President of QA (if needed)			

4

1 8.11.2 FIELD ACTIVITIES

2 During field sampling activities, field duplicate samples and trip blanks will be collected  
 3 and analyzed to help monitor the quality of the overall program. The types and frequency  
 4 of field control samples are discussed in Section 8.9 and listed on Table 5-1. Table 8-4 de-  
 5 scribes the corrective actions that will be taken to remedy out-of-control field conditions  
 6 should they occur.

7 **TABLE 8-4**

8 **TYPICAL CONDITIONS AND CORRECTIVE ACTIONS**  
 9 **FOR FIELD PARAMETERS**

Parameter	Condition	Corrective Action(s)
Trip blank sample	Contains detectable amounts of target compounds	Verify samples and sample containers are stored away from potential sources of fuels and solvents Identify and eliminate potential sources of volatile organics from sample labels, pens, seals, and preservatives Verify method blank from sample batch contains no detectable contamination Resample location, if necessary
Duplicate sample	Precision outside limit	Modify sample collection procedure Evaluate results of other QC samples for potential matrix effects
Field instruments	Out of calibration or not calibrating	Clean probes and recalibrate Obtain fresh calibration standard solutions Perform maintenance check on instrument Obtain new instrument
Equipment blank sample	Contains detectable amount of target compounds	Verify that trip blank from sample batch contains no detectable contamination Modify decontamination procedure Resample location, if necessary

10  
11  
12

## 9.0 SCHEDULE

The microwave regenerated GAC test schedule is presented as an engineering network analysis on Figure 9-1.

FIGURE 9-1 Project Schedule  
Microwave Regenerated GAC Test  
McClellan AFB, CA

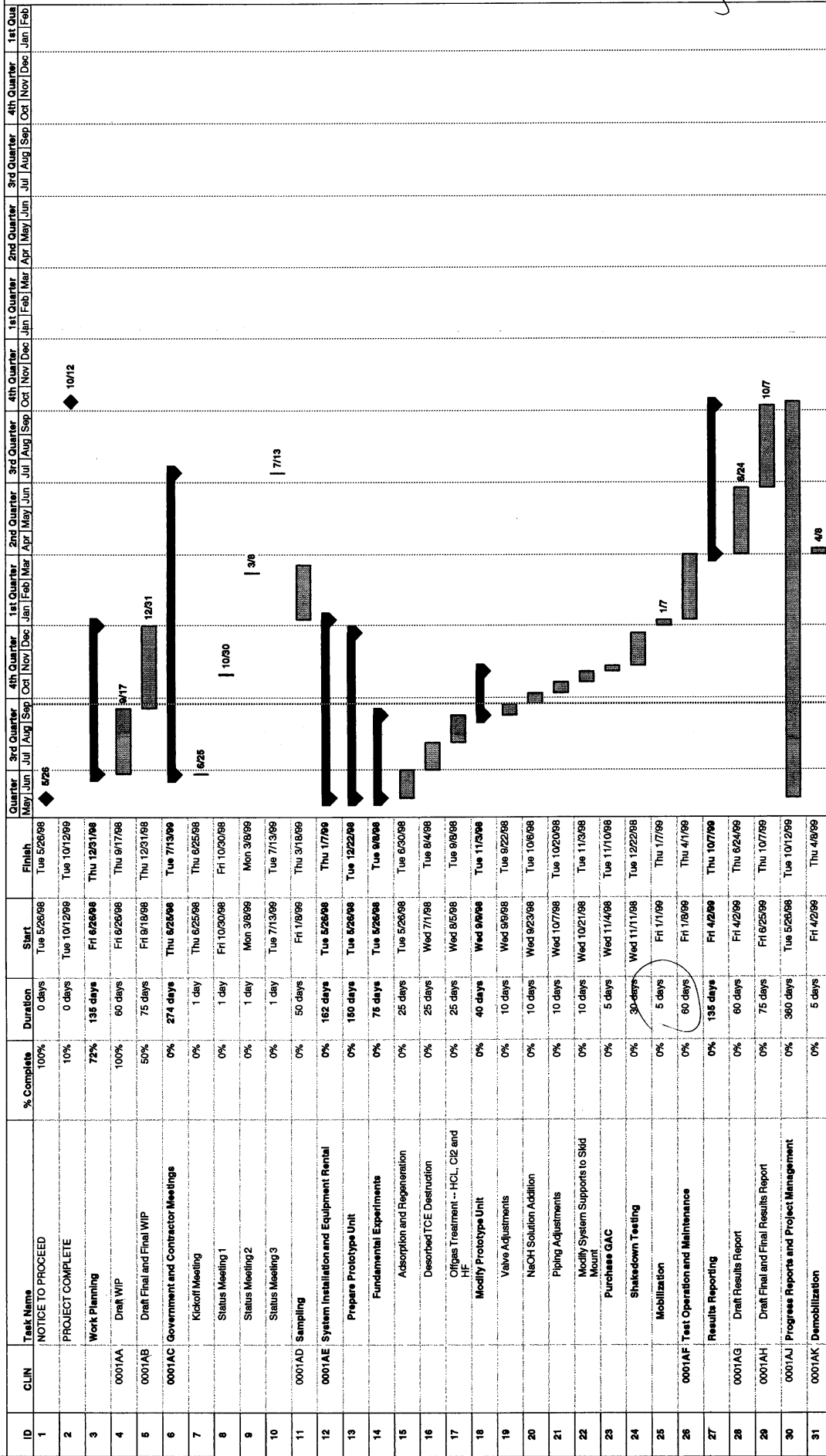

652  
no +  
90

Project: METRIC Microwave  
Date: Wed 9/23/98

Task Summary

Milestone

External Tasks

Project Summary

Roll Up Split

Split

# 10.0 MANAGEMENT AND STAFFING

1 M&E will manage the microwave regenerated GAC test from our Sacramento office. Our  
2 teaming subcontractor for the test is the CHA Corporation. The roles and responsibilities  
3 of M&E and CHA Corporation personnel are presented in Section 8.3.

4 M&E will conduct the microwave regenerated GAC demonstration under the oversight of  
5 the McClellan AFB Environmental Management Directorate. Kevin Wong (EMR) is the  
6 project officer and will provide technical oversight of the project. He is the primary point  
7 of contact for technical issues. Tim Chapman (TRW) is the alternate point of contact for  
8 the project and will provide technical consulting during the project. Captain Stephen  
9 Whalen (EMR) is the contract project manager. Jerry Vincent (EMR) is the field team  
10 leader. Mr. Vincent will be assisted by Ben Mundell. Ben Mundell (CCCF) is the field  
11 project manager. Mr. Vincent and Mr. Mundell will be responsible for supporting the  
12 necessary utility hookups for the test unit and facilitating disposal of scrubber waste, air  
13 water separator waste, and decontamination rinseate. Larry Jaramillo (PKO) is the con-  
14 tracting officer. A listing of the McClellan Management Directorate, along with tele-  
15 phone numbers are listed below.

16 **TABLE 10-1.**

17 **McClellan Management**

NAME	TITLE	TELEPHONE NUMBER
Capt. Stephen Whalen	Contract Project Manager	(916) 643-0830 ext. 406
Larry Jaramillo	Contracting Officer	(916) 643-0741 ext. 379
Kevin Wong	Project Officer	(916) 643-0830 ext. 459
Tim Chapman	Technical Consultant	(916) 643-0830 ext. 412
Jerry Vincent	Field Team Leader	(916) 643-0830 ext. 447
Ben Mundell	Field Project Manager	(916) 643-0830 ext. 311

## 11.0 REFERENCES

- 1 AFCEE Quality Assurance Project Plan. January 1997.
- 2 Radian International, Inc., *Basewide RI/FS Quality Assurance Project Plan*, April 1997.
- 3 Telephone conversation between Jerrod Davis (Project Engineer, Metcalf & Eddy) and  
4 Jorge Deguzman (Program Coordinator, SMAQMD) on September 16, 1998.
- 5 URSG-Laidlaw, *Soil Vapor Extraction Operations and Maintenance*, Monthly Progress/  
6 Status Report for May 1998. June 1998a.
- 7 URSG-Laidlaw, *Quarterly Operations Report*, January through March 1998b.
- 8 URS Consultants, *Basewide Removal Action Work Plan for Soil Vapor Extraction*, Fi-  
9 nal, McClellan AFB, May 1996.
- 10 U.S. EPA, *Data Quality Objectives for Remedial Response Activities*. March 1987.

# **Appendix A**

## **HEALTH AND SAFETY PLAN**

# APPENDIX A

## HEALTH AND SAFETY PLAN

### INTRODUCTION

---

This document is an amendment to the McClellan Comprehensive Site-specific Health and Safety Plan (HASP) document defining general applicability and general responsibilities with respect to compliance with HASP for Metcalf & Eddy, Inc. (M&E) employees and its subcontractors. This amendment to the HASP plan addresses only hazards for workers involved with the microwave regenerable GAC test at McClellan Air Force Base (AFB).

### OBJECTIVES OF THE AMENDMENT TO THE COMPREHENSIVE SITE HEALTH AND SAFETY PLAN

This Amendment to the HASP was produced to ensure that all safety, health and environmental procedures are followed and that all M&E employees and subcontractors are protected from hazards at the microwave regenerated GAC test. In addition, this amendment is intended to meet the requirements of California's Injury and Illness Prevention Plan (IIPP), 8 California Code of Regulations (CCR) §3203. This document has been prepared to establish safe procedures and practices in accordance with the Occupational Safety and Health Administration (OSHA) requirements under 29 California Federal Register (CFR) 1910 - 1926 and Title 8 of the CCR. This HASP applies to all contractors and subcontractors working at the site. Personnel on the site, including visitors, will be informed of the site emergency response procedures and any potential fire, explosion, health, or safety hazards of the operation. (see Attachment 1)

For workers at the microwave regenerated GAC test, this plan must be reviewed and an agreement to comply with the requirements must be signed prior to entry. Personnel who come into the test area will be given the materials in Tables 1-6 and Figure A-1 (Site Map/Hospital Route), then advised on emergency procedures.

This HASP was prepared in accordance with the H&S standards, provisions, and requirements specified in the following regulations and guidance documents:

- Occupational Safety and Health Administration, *Standards for Hazardous Waste Operations and Emergency Response*. Title 29 CFR 1910.120
- California Department of Industrial Relations, Division of Industrial Safety (Cal/OSHA), *General Industry Orders for Hazardous Waste Operations and Emergency Response*. Title 8 California Code of Regulations 5192.

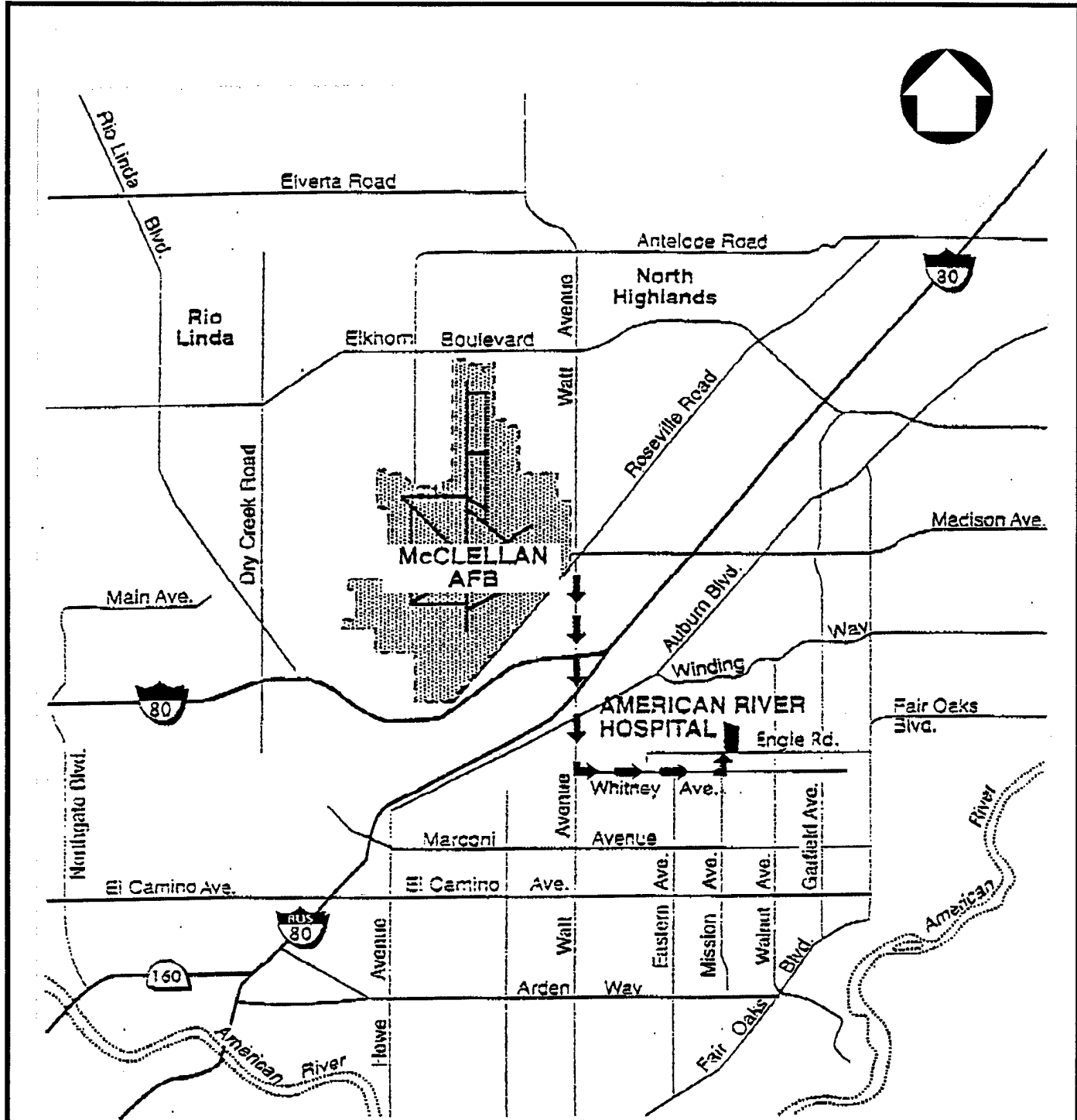

AMERICAN RIVER HOSPITAL  
 4747 ENGLE ROAD  
 CARMICHAEL, CA. 95608  
 (916) 848-2100

<b>McCLELLAN AFB METRIC CONTRACT          COMPREHENSIVE HEALTH &amp; SAFETY PLAN</b>		<b>FIGURE          A-1</b>
<b>ROUTE TO          AMERICAN RIVER HOSPITAL</b>		
 <b>M&amp;E</b> Metcalf & Eddy Inc.	<b>JOB NO:          024229</b>	<b>DATE:          SEPT. 1998</b>

ACGIH 1998 TLVs and BEIs, *Threshold Limit Values for Chemical Substances and Physical Agents*.

- Army Corps of Engineers, *Safety and Health Requirements Manual* (EM-385-1-1, October 1992)
- Federal and California Occupational Safety and Health Regulations pertaining to Air Contaminate Exposure limits, 29 CFR 1910.1000 and Title 8 CCR 5155.
- Metcalf & Eddy, Inc., *Health & Safety Practices and Work Procedures, and Injury and Illness Prevention Program*.

The primary objectives of this amendment are to:

- assess potential site hazard before the work is initiated.
- make sure that all personnel are aware of potential hazards.
- minimize or mitigate potential hazards.
- provide a means to protect personnel and report incidents.
- complete demonstration with zero reportable incidents.

## HAZARD ASSESSMENT

---

### SITE CHARACTERIZATION AND ANALYSIS

The general hazards associated with the test include those posed by the microwave, chemicals hazards of the effluent and incoming gases, and those hazards that arise from the extraction wells and/or the existing SVE operations at the site. The principle hazard in the microwave process itself is the potential for exposure to electromagnetic radiation in both the electric and magnetic fields. In addition, the microwave unit is equipped with a catalytic oxidizer and a combustion unit. The hazards from the existing SVE system consist of safety hazards that arise from vapor extraction wells, air stripper effluent air, a collection system, vacuum system, separators, blowers, electrical switchgear, controls and safety valves, and a catalytic oxidizer for volatile organic compounds (VOCs).

Based on the preliminary site information, the following hazards are known or suspected at the site and may be encountered.

### CHEMICAL HAZARDS:

Table 1 provides chemical information, exposure levels, and health effects. Table 2 describes monitoring instruments and active levels for such instruments.

## PHYSICAL HAZARDS:

- electromagnetic radiation
- heat-related disorders
- mechanical hazards
- electrical hazards
- fire/explosion; noise

### Electromagnetic Radiation or Microwave Hazards

Microwave radiation can be transmitted, reflected, or absorbed upon striking a target (or person) following the same general principles of other electromagnetic radiation. The primary effect on the human body when exposed to microwave energy appears to be thermal. In general, the higher the frequency, the lower the potential health hazards. For example, microwave frequencies greater than 3,000 MHz are readily absorbed within the skin. However, frequencies less than 3,000 MHz can penetrate the outer layers of the skin and be absorbed in the underlying tissues. The maximum skin absorbed radiation or (SAR) occurs about 70 MHz. The 1998 ACGIH TLVs and BEIs publications p. 148, Table 1 establishes Threshold Limit Values (TLVs) for radio frequency and microwave radiation. The TLVs listed in the ACGIH publication include both the electric and magnetic fields and vary with the frequency. Generally, microwave energy of the type being employed at the site in this study should not, unless something is significantly wrong, even begin to approach those levels proscribed by the ACGIH. However, any excursion above the listed threshold limit shown in Table 2 will require stopping the test and studying the equipment for leakage. It is not anticipated that the power intensity will be at or anywhere near this critical range. The power and intensity of the microwave radiation will be conducted with a Narda 8512 Industrial Compliance Meter or equivalent. The monitoring will include the coverage of the entire microwave and areas where employees will be required to work in the following manner.

**Table 1.**  
**CHEMICAL HAZARDOUS PROPERTIES**  
**SITE-SPECIFIC HEALTH AND SAFETY PLAN**

Compound	CAS Number	Water Solubility	Specific Gravity	Vapor Density	Flash Point (°F)	Vapor Pressure	LEL UEL	Ion Potent (eV)	TLV-TWA	IDLH Level	Odor Thresh (ppm)	Haz Prop	Acute Exposure Symptoms
Acetone	67-64-1	Miscible	0.8	2.0	0	180 mm	2.5% 13%	B.69	250 ppm	2500 ppm	0.1-699	Fl, Tx, Vol	Diz, Drow, Eye, Resp, Skin
Benzene	71-43-2	Soluble	0.8765	2.8	12	75 mm	1.2% 7.8%	B.24	0.5 ppm	500 ppm	1.4-120	Fl, Tx, Ca	CNS, Coma, Conv, Diz, Drow, Eye, Head, Naus, Resp, Skin, Trem, Vom, Weak
Carbon tetrachloride	56-23-5	0.5%	1.5967	5.3	N/F	91 mm	N/F	11.47	5 ppm	200 ppm	2-700	Tx, Vol, Ca	Abd, CNS, Coma, Diz, Diar, Drow, Fevr, Head, Naus, Resp, Skin, Trem
Sodium Hydroxide	1310-73-2	Soluble	2.13	N/A	N/F	0 mm	N/F	N/A	2 mg/M <sup>3</sup>	10 mg/M <sup>3</sup>	odorless	TX, Corr	Severely irritated eyes, nose, throat and respiratory system.
Chloroethane (ethyl chloride)	75-00-3	0.6%	0.8978	2.2	-58	5 mm	3.8% 15.4%	10.97	100 ppm	3800 ppm	4-2	Fl, Tx, Vol	CNS, Diz, Drow, Eye, Head, Resp, Skin, Trem
Chloroform	67-66-3	0.8%	1.4832	4.12	N/F	160 mm	N/F	11.42	2 ppm ST	500 ppm	50-307	Tx, Vol	CNS, Coma, Conv, Diar, Eye, Head, Naus, Resp, Skin
Chloromethane (Methyl chloride)	74-87-3	.74%	0.9159	1.8	32	350 mm	8.1% 17.4%	11.28	5 ppm	2300 ppm	>10	Fl, Tx, Vol, Ca	Abd, CNS, Coma, Conv, Conf, Diz, Diar, Eye, Fevr, Head, Naus, Trem, Vom, Weak
1,2-Dichlorobenzene (o-Dichlorobenzene)	95-50-1	0.01%	1.234	N/I	151	1.3 atr	2.2% B.2%	B.06	50 ppm	200 ppm	0.3-50	Fl, Tx, Scarc	Diz, eye, Head, Resp, Skin
1,4-Dichlorobenzene (p-Dichlorobenzene)	106-46-7	Slightly	1.30	N/I	150	1.2 atr	2.5%	8.98	10 ppm	150 ppm	0.18-30	Fl, Tx	Eye, Resp, Skin
Dichlorodifluoromethane	75-71-8	Insoluble	1.486 @ 30°C	4.1	N/A	5.7 atr	N/A	11.75	1000 ppm	15,000 ppm	N/I	Tx, Vol	CNS, Resp System, Diz
Dichlorotetrafluoroethane	76-14-2	0.01%	1.29	4.6	N/A	0.01 mm	N/A	12.20	1000 ppm	15,000 ppm	N/F	Tx	CNS, Resp System
Chlorobenzene	108-90-7	0.05%	.97	3.1	82	9 mm	1.3% B.6%	B.07	75 ppm	1000 ppm	0.1-60	Tx, Vol, Fl	Eye, Skin, Resp System, CNS, Liver
Benzyl chloride	100-44-7	0.05%	0.89	3.7	153	1 mm	1.1%	N/E	1 ppm	10 ppm	0.01-31	Tx, Vol, Fl	Eye, CNS, Skin, Resp
1,1-Dichloroethane (DCA)	75-34-3	0.6%	1.1757	8.4	22	182 mm	6% 16%	11.06	100ppm	3000 ppm	49-1359	Fl, Tx, Vol	Abd, Diar, Drow, Eye, Resp, Skin, Trem
1,2-Dichloroethane (ethylene dichloride)	107-06-2	0.9%	1.2554	3.4	55	64 mm	6.2% 16%	11.05	1 ppm	50 ppm	6-185	Fl, Tx, Vol, Ca	CNS, Coma, Diz, Diar, Eye, Naus, Resp, Skin, Trem, Vom
1,1-Dichloroethene (DCE) (Vinylidene chloride)	75-35-4	0.04%	N/I	3.4	14	500 mm	6.5% 11.4% 15.5%	10.00	5 ppm	N/E	190	Fl, Tx, Vol, React, Ca	CNS, Eye, Resp, Skin

**Table 1.**  
**CHEMICAL HAZARDOUS PROPERTIES**  
**SITE-SPECIFIC HEALTH AND SAFETY PLAN**

Compound	CAS Number	Water Solubility	Specific Gravity	Vapor Density	Flash Point (°F)	Vapor Pressure	LEL	Ion Potent (eV)	TLV-TWA	IDLH Level	Odor Threshold (ppm)	Haz Prop	Acute Exposure Symptoms
1,2-Dichloroethene	540-59-0	Soluble	1.27	3.34	N/I	N/I	B.7% 12.8%	B.65	200 ppm	4000 ppm	N/I	Fl, Tx, Vol	Eye, Resp, Skin
1,3-Dichloropropene	542-75-6	0.2%	1.2	3.8	77	28 mm	5% 14.5%	N/I	1 ppm	N/E	N/I	Fl, Tx, Vol	Abd, CNS, Diar, Eye, Head, Naus, Resp, Skin, Trem
Ethylbenzene	100-41-4	0.01%	0.867	3.7	55	7 mm	1.0% 6.75%	8.76	100 ppm	800 ppm	0.1-200	Fl, Tx, Vol	Abd, CNS, Diz, Drow, Eye, Head, Naus, Resp, Skin, Uncon, Vom, Weak
Methyl ethyl ketone (MEK, 2-Butanone)	28%	353 g/l	0.805	2.41	16	78 mm	1.4% 11.4%	B.54	200 ppm	3000 ppm	0.25-85	Fl, Tx	Diz, Eye, Head, Resp, Skin, Vom
Methylene chloride	75-09-2	2%	1.335	22.9	None	350 mm	13% 23%	11.32	50 ppm	2300 ppm	160	Tx, Vol, React	CNS, Coma, Eye, Head, Naus, Resp, Skin, Uncon, Weak
Styrene	100-42-5	0.03%	0.83	3.1	88	5 mm	0.9% 6.8%	8.4	20 ppm	700 ppm	0.001-200	Tx, Fl, Vol	Eyes, Skin, Res, CNS,
Tetrachloroethene (perchloroethylene)	127-18-4	0.02%	1.6227	5.8	N/F	14 mm	N/F	B.32	25 ppm	150 ppm	2-50	Tx, Vol, CA	Abd, Coma, Diz, Drow, Eye, Head, Naus, Resp, Skin, Uncon
Toluene	108-88-3	0.07%	0.866	3.2	40	22 mm	1.1% 7.1%	8.82	50 ppm	500 ppm	0.2-70	Fl, Tx, Expl	CNS, Conv, Conf, Diz, Drow, Eye, Head, Naus, Resp, Skin, Trem, Uncon, Vom, Weak
1,1,1-Trichloroethane (TCA, Methyl chloroform)	71-55-6	0.4%	1.3390	4.6	N/F	100 mm	7.5% 12.5%	N/I	350 ppm	700 ppm	20-400	Fl, Tx, Vol, Re-act	Abd, CNS, Conv, Conf, Drow, Eye, Head, Naus, Skin, Trem, Uncon
Trichlorofluoroethane	76-13-1	0.02%	0.853	4.9	N/A	285 mm	N/A	11.99	1000 ppm	2000 ppm	N/E	Tx	Skin, Head, CNS, Liver, Reproductive System
Trichlorofluoromethane (Fluorotrichloromethane)	75-69-4	0.1%	1.7	N/I	N/F	690 mm	N/F	N/I	1000 ppm	2,000 ppm	5-209	Fl, Tx, Ca	CNS, Diz, Eye, Head, Naus, Vom
Vinyl chloride	75-01-4	0.1%	0.9100	2.24	N/A	3.3 mm	3.6% 33%	B.99	1 ppm	N/E	260-300	Fl, Tx, React, Ca	Abd, CNS, Diz, Drow, Eye, Head, Naus, Resp, Skin, Weak
Xylene (o,m,p)	1330-20-7	0.02%	0.8642	3.7	63	7 mm	0.9% 6.7%	8.56	100 ppm	900 ppm	0.05-200	Fl, Tx, Vol	Abd, Diz, Drow, Eye, Naus, Resp, Skin

1g/m<sup>3</sup> = micrograms per cubic meter

g = gram

< = less than

> = greater than

°C = degrees Celsius

°F = degrees Fahrenheit

g/ml = grams per milliliter

C = ceiling is the employee exposure, which shall not be exceeded during any part of the work day

IDLH = immediate danger to life and health

lbs = pounds

LEL = lower explosive limit

m<sup>3</sup> = cubic meters

mg/l = milligrams per liter

mg/m<sup>3</sup> = milligrams per cubic meter

mg/kg = milligrams per kilogram

mm = millimeters

N/A = not applicable

N/E = none established

N/F = nonflammable

N/I = no information is available

ppb = parts per billion

ppm = parts per million

UEL = upper explosive limit

• Water solubility is expressed in different terms in different references. Many references use the term "insoluble" for materials that will not readily mix with water (e.g., gasoline). However, most of these materials are water-soluble at the ppm or ppb level. Gasoline, for example, is insoluble in the gross sense and found as a discreet layer on top of the groundwater. But certain gasoline constituents (e.g., benzene, toluene, and xylene) are found in solution in the groundwater at the ppm or ppb level. Water solubility expressed as 0.2 g means 0.2 grams per 100 grams water.

• Several chlorinated hydrocarbons exhibit no flash point in the conventional sense but will burn in the presence of a high-energy ignition source or will form explosive mixtures at temperatures above 200°F.

• Expressed as millimeters of mercury (mm Hg) under standard conditions (20°F).

• Values for Threshold Limit Value - Time Weighted Average (TLV - TWA) are Occupational Safety and Health Administration (OSHA) Permissible Exposure Limits (PELs) except where noted.

• Hazard Properties:

Ca = carcinogen

Cocarc = cocarcinogen

Cor = corrosive

Expl = explosive

F1 = flammable

Inf = infectious

Mut = mutagenic

Narc = narcotic  
Rad = radioactive  
React = reactive  
Scarc = suspected carcinogen  
Tera = teratogen  
Tx = toxic  
Vol = volatile

• Acute exposure symptoms:

Abd = abdominal pain  
CNS = control nervous system depression  
Coma = comatose  
Conf = confusion  
Conv = convulsions  
Diar = diarrhea  
Diz = dizziness  
Drow = drowsiness  
Eye = eye irritation  
Fevr = fever  
Head = headache  
Naus = nausea  
Nerv = nervousness  
Resp = respiratory system irritation  
Skin = skin irritation  
Sweat = sweating  
Trem = tremors  
Uncon = unconscious  
Vom = vomiting  
Weak = weakness

• TLV - TWA adopted by the American Conference of Governmental Industrial Hygienists (ACGIHS), which is lower than the OSHA PEL.

• Explosive concentrations of airborne dust can occur in confined areas.

• Solubility of metals depends on the compound in which the metals are present.

• TLV - TWA recommendations by the National Institute for Occupational Safety and Health (NIOSH), which is lower than the OSHA PEL.

• See information of specific compounds for more details.

• Based on benzene.

• Particulate PAHs.

• Based on Gasoline.

**Table 2.  
CHEMICAL HAZARDOUS PROPERTIES  
and MONITORING INSTRUMENTS**

Direct- Reading Instrument	Frequency/ Duration of Air Monitoring	Action Level Above Back- ground (a,b)	Contaminant	Monitoring/ Sampling Location	Action
PID	Continuous	1 ppm	Organic Vapors	At source	Introduce engineering controls (i.e., blower fans) (Level C)
Vinyl Chloride Detector Tube	Measure at 1 ppm, indicated on PID (c).	1 ppm	Vinyl chloride present at $\geq 1$ ppm	At source	Upgrade to Level C with vinyl chloride cartridge
PID	Continuous	0-5 ppm	Vinyl chloride present at $\geq 1$ ppm	Breathing zone	Level C with vinyl chloride cartridge
LEL Meter	Startup and Intermittently	10% LEL	Flammable gas	In unit and area	Leave area call SSO
PID	Continuous	>50 ppm	Vinyl chloride present at $\geq 1$ ppm	Breathing zone	Stop work; leave area; call SSO
PID or FID	Continuous	5-25 ppm	Vinyl chloride below 1 ppm	Breathing zone	Continue engineering controls. Upgrade to full face respirator; Level C with vinyl chloride cartridge
PID or FID	Continuous	>25	Vinyl chloride below 1 ppm	Breathing zone	Stop work; leave area; call SSO.

(a) Action levels for known contaminants are based upon the contaminants Permissible Exposure Level (PEL) or Threshold Limit Values (TLVs), whichever is more conservative.

#### Heat and Cold Exposure Hazards

These subjects are covered in Appendix D in the Comprehensive HASP. The weather at McClellan AFB is not considered extreme. However, the summers can be very hot (i.e. 108+ at times). Therefore, heat stress is a concern during the months of May through October. In the winter months heavy rains and cool temperatures may increase slip hazards.

#### Mechanical Hazards

System operators will inspect and test the remediation equipment and maintain it for proper performance. Operators will perform maintenance on mechanized equipment only after proper lock out/tagout procedures. All mechanized equipment must be operated in compliance with California Industrial Safety Standards as defined by Title 8 of the CCR. Mechanical equipment has been supplied with the appropriate safety guards. These guards must remain in place during operation. If guards are removed in order to make repairs, the equipment must be completely de-energized according to M&E Lock-Out Procedures. AWT policy # 903, enclosed in Appendix O of the Comprehensive HASP.

---

## Electrical and Utility Hazards

The principle control measure for electrical hazards during the microwave regenerated GAC test will be to use effective lock-out procedures and grounding.

## Noise

Excess noise exposures may be encountered near the air pollution control equipment or other process equipment associated with the project. The noise level is at or above 85 dBA. Therefore, hearing protection must be worn when personnel are to be working adjacent to such equipment or outside of the office/laboratory location at the site.

## Fires and Explosions.

The concentration of volatile and semi-volatile gases from the existing SVE influent stream is such that it should not be possible to generate an explosive atmosphere. However, a LEL meter will be used during the start up phases of the project to evaluate the potential for explosion of the incoming gas, as well as the gas generating from microwaving the carbon, for creating an explosive atmosphere. It is particularly important to use the LEL Meter when tapping into the influent and effluent streams (i.e., the process is to be shut down during the setup phases when lines are tapped into).

## Snake and Spider Safety

All personnel must be advised of the need to watch out for poisonous snakes, spiders and yellow jackets. The Site Manager or Site Health & Safety Officer will provide training for workers at the site on the types of hazards at McClellan AFB and where to expect to find them.

Rattle Snakes. The most dangerous time periods for encountering poisonous snakes are in the early morning and at night when snakes are moving around. In the day time, snakes are generally inactive. However, during the heat of the day, snakes may take cover under equipment or in any shaded area. Moving such equipment will be done with caution.

Workers will not provoke snakes. If a snake is discovered, avoid contact, do not walk over or try to move with a stick or rod or otherwise scare the animal. If a snake is in the area where work is necessary, work must stop until it can either be done safely or the snake is out of the area.

Black Widow Spiders. Black widow spiders may reside in many areas at McClellan AFB. The following list of typical residing places represents only a fraction of the places where these spiders may be found:

- around foundations of buildings.
- inside building mechanical rooms.
- on and around equipment (under seats, engine compartments, wheel housings).
- within well boxes and casings.
- lumber and metal storage piles.

A black widow spider's web can be identified by the relatively strong, tacky, random strands that make up the web. The spider typically resides in cracks, corners, crevasses or beneath or between boards or metal pieces or inside of pipe. Black widows are relatively shy and will not typically leave their hiding

---

spots. If disturbed, the spider may not come out for several minutes. This means you may pick up a board or pipe occupied by a black widow and carry the spider with you without even being aware of it.

All materials will be thoroughly inspected prior to transport and use.

### Hornet/Yellow Jacket Safety

Hornets and Yellow Jackets may be found in a number of locations at McClellan AFB. The following list of typical residing places represents only a fraction of the places where hornets or yellow jackets may be found:

- around plant life that is blooming
- inside building mechanical rooms
- on and around equipment where activity is not routine
- low traffic areas
- in basement locations or on drain ducting near roof
- almost anywhere

The real key is to avoid contact with these insects. Do not disturb nests or cones. Do not attempt to spray with insecticide. If the nests or cones must be removed contact the Health and Safety Officer at the site and he/she will work through base channels to have it removed by professionals.

### First Aid for Snake, Spider, or Other Insect Bites.

At least one worker at each work site will be currently certified with the American Red Cross for standard first aid and adult CPR. The first aid steps below should be calmly administered immediately following poisonous snake or spider bite.

1. Call 117 and ask for helicopter/ambulance service.
2. Quiet and calm the victim.
3. Splint the affected limb if applicable.
4. Use a loose tourniquet.
5. Transport to emergency care.
6. If it can be done safely, kill the snake or spider and bring it in with the patient.
7. No ice should be provided to victim.
8. No food or water should be provided to victim.
9. No cutting or suction of the snake bite or insect bites should occur.

For hornet/yellow jacket bites ice may be used to reduce pain. The individual should be taken for medical evaluation and treatment as soon as possible. If the person is allergic to the insect bite, then emergency medical care should be taken by calling 117 and requesting ambulance, as well as, providing information about the incident to the responding personnel.

## Work Zone Definition and Code of Safe Practices (IIPP)

The area in which the microwave regenerated GAC test is being conducted is by definition and exclusion zone area. However, visitors may come into the area with the approval of the site superintendent or manager. Safety glasses and hearing protection must be worn by visitors who are walking through the area.

**Table 3.**  
**HEALTH & SAFETY ORGANIZATION CHART**

<b>Position</b>	<b>Name</b>	<b>Phone Number</b>	<b>Duties</b>
Site Safety Officer	TBA	TBA	To serve as on site safety officer and ensure compliance with site specific health and safety plan
Regional Health and Safety Officer	William C. Collier, CIH	916-567-4245	To write the site specific health and safety plan, to monitor compliance at the site and conduct routine audits.
Corporate Health & Safety Officer	Richard Renzi	781-224-6450	To develop and implement corporate health and safety policies, provided guidance to the regions and audit some sites.

**Table 4.**  
**WORK ZONE RULES**

### **WORK ZONE RULES** **(Codes of Safe Practices)**

1. There will be no smoking, eating, chewing gum or tobacco, drinking or application of cosmetics in the work zone
2. All M&E or subcontractor personnel shall bring to the attention of the Site Health & Safety Officer any unsafe condition or practice associated with site activities.
3. Hands, face and all other potentially contaminated areas shall be thoroughly cleaned prior to smoking, eating or leaving the site.
4. Personnel must avoid unnecessary contamination (i.e., walking through known or suspected "hot" zones or contaminated puddles, kneeling or sitting on the ground, leaning against potentially contaminated barrels or equipment).
5. Respiratory devices may not be worn with beards, long sideburns, or under other conditions that prevent a proper seal.
6. No non-project personnel may be allowed on-site without the prior knowledge and consent of the M&E Project Manager, Site Manager or Site Health and Safety Officer.
7. All project personnel who are likely to wear air purifying or air supplied respirators must first meet the training and medical requirements of 29 CFR 1910.120 and 29 CFR 1910.134.

---

**WORK ZONE RULES**  
**(Codes of Safe Practices)**  
*(Continued)*

8. All accidents and/or injuries shall be immediately reported to the Site Health & Safety Officer. If necessary, a first report of injury will be initiated by the site safety officer and provided to the Regional Safety Officer for processing. See Appendix A of the Comprehensive Safety and Health Plan.
9. Daily safety meeting will be held at the start of each site operation to discuss current site conditions, field tasks being performed, plan modifications and work concerns.
10. If there is rainfall or other hazard increasing occurrence, safety considerations will be increased proportional to the increased risk.

---

## ENGINEERING CONTROLS AND PERSONAL PROTECTIVE EQUIPMENT

---

### ENGINEERING CONTROLS

Engineering controls would include such units as ventilation units or enclosed processes that help to make sure that chemicals entering and exiting the microwave regenerated GAC test unit do not migrate out of the process units and cause exposure to operators. In addition, lockout/tagout must be employed when performing maintenance on equipment.

### PERSONAL PROTECTIVE EQUIPMENT

The level of protection to be worn on this site will be level D. This level of protection will consist of:

- coveralls or Tyvak suits.
- gloves - chemical resistant to acids and caustics.
- safety glasses - at all times in the process area or when handling chemicals during laboratory test.
- safety shoes with steel toes and chemical resistant soles.
- hearing protection when near the air pollution control or process equipment for the CatOx unit.

### Reassessment of Protection Program

The Level of Protection provided by PPE selection shall be upgraded or downgraded based upon a change in site conditions or findings of investigations (see Table 2).

When a significant change occurs, the hazards should be reassessed. Some indicators of the need for reassessment are:

- 
- commencement of a new work phase.
  - change in job tasks during a work phase.
  - change of season/weather.
  - when temperature extremes or individual medical considerations limit the effectiveness of PPE.
  - contaminants, other than those previously identified, are encountered.
  - change in ambient levels of contaminants.
  - change in work scope which effects the degree of contact with contaminants.

If there is an upgrade, the most likely upgrade would be to level C. Level C personal protective equipment would consist of:

- chemical resistant coveralls.
- gloves - chemical resistant to acids and caustics.
- eye goggles and face shields, safety glasses - at all times in the process area or when handling chemicals during laboratory test
- hearing Protection when near the air pollution control or process equipment for CatOx.
- safety shoes with steel toes and chemical resistant soles.
- full face air purifying respirators with organic vapor cartridges during cleanup or containment of spills from process lines or of process chemicals.

**Note: When operating CatOx System for setup, Level C with organic vapor cartridges must be worn until LEL and PID indicate a downgrade of respirator is appropriate.**

## **PERSONNEL TRAINING REQUIREMENTS**

---

All personnel performing work on the microwave regenerated GAC test shall have received training in accordance with OSHA 29 CFR 1910.120(e)(3) or California equivalent. Documentation of training requirements is the responsibility of M&E Health and Safety Officer.

### **TRAINING AND BRIEFING TOPICS**

The Site Health and Safety Officer (SHSO) shall hold a pre-entry briefing at the start of each workday, and at any other time as necessary to ensure that all site personnel are properly apprised of site specific health and safety issues. In addition to the requirements set forth at 29 CFR 1910.120 and the pre-entry training additional training will be provided. The additional training will include information about the warning signs of chemical exposure, use of interpretation of the LEL meter, use of micro-

wave monitoring instrument, lockout/tagout equipment, hearing protection and other safety issues. Attachment 1 verifies that workers have read the HASP.

## SITE MONITORING

The microwave regenerated GAC test will be in a closed system. Therefore, exposure to chemicals will be limited unless there is an atmospheric release. Because the contaminated vapors coming into the microwave regenerated GAC test unit are under positive pressure, the potential for an atmospheric release is somewhat increased. As such, PID readings, along the positive pressure line leading to the test unit will be monitored with PID on a daily basis. In addition, pressure readings will be closely monitored.

In the event of a release, air monitoring will be conducted. This will include the use of a meter to indicate the percentage of the lower explosive level of the gaseous mixture, detector tubes for vinyl chloride and the use of a PID to indicate exposure to various chlorinated and nonchlorinated organic compounds. On the other hand, microwave radiation emissions will be monitored at the start up of operations and intermittently throughout the test to ensure that no personnel are exposed to electromagnetic radiations above those listed in the ACGIH TLV guidelines mention above. The section governing the monitoring of electromagnetic radiation is discussed above in paragraph B.2.3.1 covering the use of microwave monitoring instruments. For instrumentation use, action levels and protective actions please refer to Table 5.

**Table 5. MICROWAVE EXPOSURE LIMITATIONS**  
**Action Levels for Microwave Exposure**  
**Metric Project, McClellan AFB**

Head Area	Groin Area	Arm Area
<b>Magnetic Field</b>		
80 A/m	80 A/m	80 A/m
<b>Electric Field</b>		
300 V/m	300 V/m	300 V/m

These figures are half the TLV.

## MEDICAL SURVEILLANCE REQUIREMENTS

Prior to being assigned to site activities, all site personnel working on the microwave microwave regenerated GAC test shall participate in a medical surveillance program as required by 29 CFR 1910.120(f). At a minimum, this medical monitoring shall consist of:

- a complete medical and work histories.
- a physical examination.
- a pulmonary function tests (FVC and FEV1).
- a chest X-ray (every 2 years).
- an EKG, upon physician recommendation.
- an eye examination and visual acuity.

- 
- an audiometry.
  - an urinalysis.
  - a blood chemistry for chlorinated hydrocarbons and nonchlorinated hydrocarbons

The pre-assignment physical should categorize employees as fit-for-duty and able to wear respiratory protection. The pre-assignment physical categorizes employees as fit-for-duty and able to wear respiratory protection.

## **DECONTAMINATION PLAN**

---

### **PERSONNEL DECONTAMINATION PROCEDURES**

All personnel who enter into the microwave regenerated GAC test area are subject to the requirements for decontamination. The purpose of decontamination is to ensure that no toxic materials from the site are taken off the site. Generally, employees will wear tyvek coveralls at the site. Such tyvek coveralls should not be taken off the site by the employees and may be thrown away in ordinary trash. However, if the tyvek suits become saturated or otherwise contaminated with liquid from the influent or effluent lines, such suit should be tested to determine if they may be classified as hazardous waste prior to disposal. Employees must wash their face, hands, arms and other areas that may become contaminated by contact with contaminated liquids or reactive chemicals prior to eating, drinking, smoking, or leaving site.

### **EQUIPMENT DECONTAMINATION PROCEDURES**

All equipment which comes into direct contact with potentially contaminated water will be cleaned on site prior to removal from the site to minimize contact of other workers who may touch such equipment in process of handling or repairing such equipment. Note: All electronic monitoring equipment will be wrapped in plastic to eliminate the need for extensive decontamination protocols which could harm the electronics.

### **EMERGENCY CONTACTS**

---

This section provides current emergency contact information. For specific emergency procedures please refer to the Comprehensive Health and Safety Plan for M&E for its McClellan operations. The emergency phone numbers are listed in Table 6.

**Table 6.  
EMERGENCY CONTACT LIST**

<b>Organization</b>	<b>Contact</b>	<b>Telephone</b>
Fire Department	Fire Department	On Base: 117 Private: (916) 643-6666 Off base: 911
Police	Police Department	On Base 112 Private: (916) 634-6161 Off Base: 911
Ambulance or Emergency Care on Base	Ambulance Service	On Base: 117 Private: (916) 643-7333 Off Base: 911
Hospital - American River 4747 Engle Road Carmichael, CA 95608	Hospital – primary	(916) 848-2100
Poison Control Center		(800) 458-5842
Hospital - burn control	UC-Davis	(916) 734-3636
California Department of Health Services	State Regulatory contact	(916) 445-3531
EPA Emergency Response Team		(800) 733-7023
William C. Collier, CIH	Safety officer for M&E	(707) 455-7835 Home (916) 567-4245 Office
State Spill Contractor	California State Emergency Service	(916) 371-5747

## SPILL CONTROL PLAN

Site-specific spill control plan information is presented in Tables 7 and 8 of this appendix.

## Table 7. SITE SPECIFIC SPILL PLAN

<b>SITE SPECIFIC SPILL PLAN</b>		<b>DATE:</b> 22 September 1998	<b>FACILITY NO:</b> Microwave
<b>SITE DESCRIPTION:</b> (IRP) Microwave METRIC Project			
<b>ON-BASE SPILL DISCOVERY AND NOTIFICATION PROCEDURES</b>			
<p><b><u>REPORT SPILL OR POTENTIAL RELEASE OF:</u></b></p> <ul style="list-style-type: none"> <li>▪ Any quantity of an extremely hazardous substance (EHS).</li> <li>▪ 1 lb/1 pint or more of a hazardous substance.</li> <li>▪ Any quantity if fire or health hazard is present.</li> <li>▪ Any quantity of mercury.</li> <li>▪ Any quantity from a pressurized system.</li> <li>▪ Bulging or abandoned drums (<b>DANGER - Don't Touch!</b>)</li> </ul> <p style="text-align: center;"><b>REPORT IMMEDIATELY TO:</b>  <b>McClellan Fire Department</b>  <b>117 or 643-6666</b></p>	<p><b><u>ACTIONS TO TAKE:</u></b></p> <ul style="list-style-type: none"> <li>▪ Alert personnel - Evacuate if necessary.</li> <li>▪ Information to report to Fire Dept.: <ul style="list-style-type: none"> <li>• your name and phone number</li> <li>• location of spill</li> <li>• substance spilled</li> <li>• estimated amount spilled</li> <li>• extent of spill</li> <li>• other pertinent information (e.g., injuries)</li> </ul> </li> <li>▪ Isolate the spill area and follow site specific procedures.</li> </ul>		
<b><u>SITE RESPONSIBLE INDIVIDUALS:</u></b>	<b><u>NAME</u></b>	<b><u>ORG. SYMBOL</u></b>	<b><u>PHONE NO.</u></b>
Unit Environmental Coordinator:	Mike Poston	EM	(916) 643-2517 (ext. 308)
Supervisor:	Greg Haling	M&E	(530) 342-6958
Alternate Supervisor:	Gary Haddix	M&E	(916) 929-2077
Area Monitor:	Sarah Jane Blubaugh	TI	(916) 643-2704
Safety Manager:	Bill Collier	M&E	(916) 567-4245
<b><u>OIL AND HAZARDOUS SUBSTANCE DATA (Indicate if Material (M) or Waste (W)):</u></b>			
<b><u>Description</u></b>	<b><u>Quantity (Amount/Unit)</u></b>	<b><u>Type of Container</u></b>	
Sodium Hydroxide (M)	100 Pounds	BAG	
PVC Glue (M)	6 Quarts	Quart	
PVC Primer (M)	6 Quarts	Quart	
Specific contaminants of concern and expected concentrations are included in Table 2-1 (Page 2-6) of this report.			
<b>MSDS LOCATION:</b> On Site			
<b><u>EVACUATION PROCEDURES:</u></b>			
Evacuate personnel without PPE from immediate area of spill.			
<p><b><u>ON-SITE PERSONAL PROTECTIVE/SAFETY EQUIPMENT</u></b></p> <p>None  Require PPE individually issued and kept in each person's locker</p> <p>Issued PPE consist of:</p> <p>Full-face respirators  Organic vapor cartridges  Gloves  Goggles  Face shield  Apron  Safety shoes  Overalls</p>	<p><b><u>ON-SITE SPILL CLEANUP KIT:</u></b></p> <p>Kit contains:</p> <ol style="list-style-type: none"> <li>1. Absorption material</li> <li>2. Broom</li> <li>3. Shovel</li> </ol>		
<b><u>SITE SPECIFIC PROCEDURES:</u></b>			
<ol style="list-style-type: none"> <li>1. Call Fire Department At 117.</li> <li>2. Evacuate all personnel from the immediate area who are not PPE equipped.</li> <li>3. Stop the source of the spill, if possible.</li> <li>4. Notify your immediate supervisor.</li> <li>5. Neutralize acid spill with base solution; Neutralize base spill with acid solution; wash down and pump to proper tank for treatment.</li> </ol>			

**Table 8. SPILL CONTROL PLAN CONTACTS**

**BASE EMERGENCY**

**FIRE**            643-6666  
**MEDICAL**       643-7333

<b>M&amp;E CONTACTS</b>	<b>OFFICE</b>	<b>FAX</b>	<b>HOME</b>	<b>CELLULAR</b>	<b>PAGER</b>
Greg Haling Project Manager	(530) 342-6958	(530) 342-2874	(530) 898-8365		
Bill Collier Health & Safety Manager	(916) 567-4245	(916) 567-4242	(707) 455-7835		800-946-4646 ID#20004017
Bill Lampkin	(530) 342-6958	(530) 342-2874	(530) 893-5600		571-1872
Lonnie Witzke			(530) 671-3112		
M&E Sacramento Office	(916) 567-4200	(916) 567-4242			

---

## HEALTH AND SAFETY PLAN APPROVAL FORM

This Site Health and Safety Plan amendment has been written for the exclusive use of Metcalf & Eddy, inc. employees on the microwave regenerated GAC project. M&E claims no responsibility for its use by others. The plan is written for the specified site conditions, dates, and personnel and must be amended if these conditions change.

This plan applies only to the microwave regenerated GAC demonstration – Sacramento, CA

PREPARED AND REVIEWED BY:

---

Regional Health & Safety Coordinator

---

Date

---

Project Manager

---

Date



# Appendix B

## **SAMPLE COLLECTION AND ANALYSIS STANDARD OPERATING PROCEDURES**

**EPA METHOD TO-13**

@ Air Toxics Limited  
STANDARD OPERATING PROCEDURE

ANALYSIS OF SEMI-VOLATILE ORGANIC COMPOUNDS  
COLLECTED ON PUF CARTRIDGES

EPA METHOD TO-13/Modified 8270

SOP #10

Effective Date: 8/13/97  
Revision #: 2  
Reason for Revision: To update to current procedures.

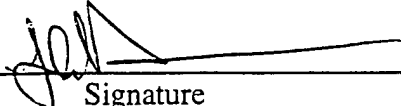
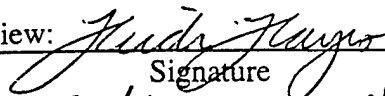
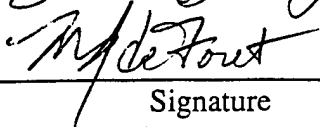
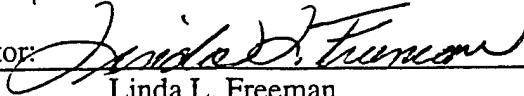
Updated By:		JOHN HEFFELFINGER	CHEMIST	8-13-97
	Signature	Print	Title	Date
Technical Review:		HEIDI HAYES	TEAM LEADER	8-13-97
	Signature	Print	Title	Date
QA Review:		Marie-Jeanne de Foret	QA Mgr	8/13/97
	Signature	Print	Title	Date
Laboratory Director:		Linda L. Freeman		8/13/97
				Date

**1.0 PURPOSE**

- 1.1 To provide a procedural guide for the application of EPA Method TO-13 to the analysis of polynuclear aromatic hydrocarbons (PAHs) in ambient air collected on PUF (polyurethane foam) cartridges.
- 1.2 To describe modifications to the analysis which would enable reporting of semi-volatile compounds under EPA Method 8270.

**2.0 PROCEDURES**

- 2.1 Filters and adsorbent cartridges are cleaned using solvents and vacuum dried. Cartridges are sent to the field in Teflon lined screw capped jars wrapped tightly in aluminum foil to prevent degradation by UV light. Following sampling the filters and cartridges are subjected to soxhlet extraction with methylene chloride and concentration. Analysis is performed using a quadrupole GC/MS in the full scan mode. Detection limits are approximately 1 µG/cartridge.

2.2 Materials, Supplies and Equipment

Sample cartridges and filters

Acid washed quartz fiber filters - 105 mm

PUF plugs

Aluminum foil

Soxhlet extractors capable of extracting filters and adsorbent cartridges, 500 mL flask and condenser

Zymark Automated Liquid Concentrator equipped with 1 mL vials

Polyester gloves for handling filters and cartridges

Vacuum oven

Methylene chloride - Reagent Grade, Glass Distilled

Sodium Sulfate, anhydrous (purified by triplicate washing with methylene chloride)

GC/MS system equipped with a temperature programmable oven suitable for splitless injection or capillary cool on-column injection. The capillary column should be connected directly to the ion source. The GC/MS system should be capable of scanning from 35 to 500 amu with a 1 second scan rate. Tuning is achieved by injecting 50 nG of decafluorotriphenylphosphine (DFTPP).

Capillary column - 30 m X 0.25 mm DB-5.625 with 0.5 µm film thickness.  
(J&W Scientific, Inc. - Folsom, CA)

- 2.3 Analysis is carried out on a HP 5972 MSD system and HP5890 GC Series II equipped Electronic Pressure Control and split/splitless injection port. The system uses Thru-Put systems operating software.
- 2.4 The GC/MS operating conditions include:
- Mass Range: 35 - 500 amu
  - Scan Time: 0.76 seconds per scan
  - Injection Port Temperature: 280°C
  - Initial Column Temperature and Hold Time: 50°C for 1.00 min.
  - Column Temperature Program: 10°C/min.
  - Final Column Temperature and Hold Time: 310°C for 7.83 min.
  - Detector Temperature: 280°C
  - Mode: Splitless/Constant Flow
  - Injection Pressure: 13.6 psi at 50°C
  - Purge On: 0.70 min.
  - Carrier Gas: Helium
- 2.5 Interferences to this method generally include contamination from phthlate esters found in plastic products. The use of plastic products is kept to a minimum to help eliminate this problem.
- Carryover from a high level sample may also cause interference. Therefore a reagent blank is analyzed prior to continuation of sample analysis when an unusually high level sample is analyzed. If an extremely high level sample is analyzed within an autosampler sequence, all succeeding affected samples are re-analyzed to ensure that the correct concentrations are reported.
- 2.6 Normal laboratory safety precautions must be used when preparing standards from neat materials for this method and when analyzing samples. These precautions include working in a fume hood, wearing eye protection and wearing a laboratory coat when handling neat materials. Also, precautions must be taken to avoid skin contact with neat materials. Refer to the compound specific MSDS for additional information. Care must also be taken when handling syringes to ensure that a needle stick does not occur.
- Precautions must be taken during the extraction procedures to avoid contact with the methylene chloride used during extraction. These precautions include working in a fume hood, wearing eye protection, avoiding skin contact with methylene chloride and wearing a laboratory coat.

### 3.0 **PREPARATION OF SAMPLING MEDIA**

- 3.1 **Glass fiber filters** - Care should be taken to always handle the cleaned filters with polyester gloves.
- 3.2 **PUF Cartridge** - PUF inserts are generally 6.0 cm cylindrical plugs cut from 3 inch foam stock. The PUF material is initially cleaned by soxhlet extraction with methylene chloride for a minimum of 18 hours at 4 cycles per hour. The solvent is changed after each six hour period. Batch size varies depending on the available equipment, but generally 20 to 30 are cleaned at one time. The extracted foam is dried for four hours at approximately 120°C in a vacuum oven. The PUF is placed into the glass sampling cartridge using polyester gloves. The cartridge is wrapped with aluminum foil, placed in a labeled container and sealed with Teflon tape. To certify the batch, the final (from the

third six hour period) methylene chloride extract is concentrated to 1.0 mL and submitted for analysis. The batch is certified if all target compounds are less than the required detection limit. A batch is identified by the preparation date and the type of PUF (e.g. 970508TO13 for PUF inserts prepared on 5/8/97). The PUF inserts that are not immediately being used in assembly of cartridges are placed in a glass jar and kept at ambient temperature until they are needed. The jar is labeled with the above batch ID. PUF inserts are randomly removed from the jar and used for QC purposes with sample extractions. PUF inserts that are not used within 3 months of preparation, will be re-certified as clean prior to use.

#### 4.0 *SAMPLE EXTRACTION*

- 4.1 ~~Samples are shipped from the field in a cooler with ice.~~ After receipt of samples, the sample identification and labeling are performed in a timely manner. The samples are stored at 4°C until extraction.

~~Extraction must be performed within one week of sample collection.~~ Place the adsorbent material and glass fiber filter in the soxhlet apparatus along with approximately 650 mLs of methylene chloride and extract for a minimum of 18 hours at 4 cycles per hour. Surrogate spiking solution (0.5 mL) is added prior to starting the extraction. Dry the BNA portion of the extract by passing it through a drying column containing approximately 10 grams of anhydrous sodium sulfate. Concentrate the dried extract to 1.0 mL using the automated Zymark concentrator. Transfer the concentrated extract to a 1 mL Teflon lined storage vial and store at 4°C until analysis. Analysis of samples must be performed within 40 days of sample extraction.

If pesticide analysis (TO-4) is required from the same PUF sample, then the extract is split after the 18 hour methylene chloride extraction. Half of the extract is taken through the remaining BNA extraction steps and half is taken through the pesticide method. The final volume is 0.5 mL if split.

- 4.2 All glassware used in the extraction process is pre-cleaned by washing in hot tap water with detergent followed by rinsing with deionized water. The glassware is further solvent rinsed with methylene chloride.

#### 5.0 *QUALITATIVE ANALYSIS*

- 5.1 Qualitative Target Compound Identification

The computer software qualitatively identifies the compound based on a mathematical comparison of the sample spectra with NBS library spectra. The analyst confirms the identification by visually comparing the sample spectra to the NBS library spectra. In the event of coelution, matrix, or some other type of interference, the following criteria are used to qualitatively identify an analyte:

- 1) The Relative Retention Time (RRT) for the analyte must be within +/- 0.06 RRT units of the RRT of the analyte in the daily continuing calibration check.
- 2) Ions present in the standard spectrum greater than 10% of the most abundant ion must be present. Also, the relative intensity of the ions greater than 10%, must be +/-20% of the intensity in the standard spectrum. The standard spectrum is generated by the system that is performing the analysis.

It may be necessary for the analyst to perform manual background subtraction of coeluting peaks to obtain a clean spectrum. The analyst must always use their discretion on any identification.

5.2 Tentatively Identified Compounds (TIC)

5.2.1 Based on the computer generated searches, the identification of the ten highest non-target unknown peaks is reported. The spectrum of these peaks are searched against the NIST library of greater than 50,000 compounds.

5.2.2 The total ion current is used for quantitation and calculation of TIC results. The total ion current of the closest (by Retention Time (R.T.)) non-interfered with internal standard is used to calculate results. If all internal standards are interfered with, the method blank's internal standards are used to calculate results. A relative response factor of "1" is assumed.

6.0 **QUALITY CONTROL**

6.1 **Tuning Criteria** - The GC/MS system must be hardware tuned to meet the criteria for a 50 nG injection of DFTPP (Table I). Analysis will not begin until all of these criteria are met. The GC/MS hardware tune check is performed prior to calibration and at the start of every 12 hour shift.

6.2 **Internal Standards** - Quantitation is based on the internal standard technique. Four  $\mu\text{L}$  of a 2000  $\mu\text{G}/\text{mL}$  internal standard spiking solution are added to a 100  $\mu\text{L}$  aliquot of the sample extract. The final concentration is 80  $\mu\text{G}/\text{sample}$  of each of the following:

Acenaphthene-d <sub>10</sub>	Naphthalene-d <sub>8</sub>
Chrysene-d <sub>12</sub>	Perylene-d <sub>12</sub>
1,4-Dichlorobenzene-d <sub>4</sub>	Phenanthrene-d <sub>10</sub>

The internal standards are selected to permit most of the target species to elute within 0.80 to 1.20 to the nearest internal standard. The base ion from the specific internal standard is used for quantitation. If interferences are noted, then a secondary ion may be selected. Base ions for the internal standards are provided in Exhibit I. The internal standard solution is added to each standard, blank and sample prior to analysis. The area counts must be within -50% to +100% of the daily check's internal standard area counts. If samples are analyzed the day of an initial calibration, the area counts of a mid-level standard are used to determine acceptance windows.

6.3 **Calibration Standards** - Calibration is achieved by using stock standards of at least six different levels which bracket the linear range of the GC/MS. One level is at the practical quantitation (PQL) limit. Standards are blended from Ultra Scientific Stock Solutions (or equivalent) to cover the working range. One  $\mu\text{L}$  of each standard is analyzed. Tabulation of the peak ion area vs. amount (nG) is performed to generate a response factor for each level using the equation:

$$\text{RRF} = (\text{A}_\text{X}\text{C}_\text{IS})/(\text{A}_\text{IS}\text{C}_\text{X})$$

Where:

- $\text{A}_\text{X}$  = Area of the peak ion for the compound measured
- $\text{A}_\text{IS}$  = Area of the peak ion for the appropriate Int. Std.
- $\text{C}_\text{X}$  = Mass of the compound measured (nG)
- $\text{C}_\text{IS}$  = Mass of the appropriate Int. Std. (nG)

6.3.1 Calibration of the GC/MS is achieved via the internal standard technique. The response factor variability over the 6 point curve must be 30% or less for the Calibration Check Compounds (CCCs). The CCC compounds are noted in below. If the relative standard deviation (RSD) for any of the CCC response factors is greater than 30%, then a new initial calibration curve is performed.

Acenaphthene	4-Chloro-3-methylphenol
1,4-Dichlorobenzene	2,4-Dichlorophenol
Hexachlorobutadiene	2-Nitrophenol
n,n-Nitrosodiphenylamine	Phenol
Fluoranthene	Pentachlorophenol
Benzo (a) pyrene	2,4,6-Trichlorophenol

The average RRF from the initial calibration curve will be used for quantitation of all compounds with  $\leq 30\%$  RSD. For projects in which the target analyte list consists of PAHs only, the RSD for all PAHs are evaluated instead of the CCCs. The RSD criteria for PAHs in this scenario is also  $\leq 30\%$ . However, when a PAH RSD is high, analysis can continue provided the following protocol is adhered to: If a compound that has a high RSD is not detected in any of the project samples, the curve is considered valid for those samples.

In the event calibration of any of the non-CCC compounds resulted in an RSD  $> 30\%$ , linear regression will be used to calculate results for that compound.

6.3.2 **Calibration Standards Preparation** - EPA Certified stock standards at a concentration of 2000  $\mu\text{G}/\text{mL}$  may be purchased from Restek or equivalent, or calibration may be prepared from the neat compound. Preparation of a 2000  $\mu\text{G}/\text{mL}$  stock standard from the neat compound can be accomplished by first weighing 100 mg of the neat compound into a 10 mL volumetric flask and diluting to volume with methylene chloride to yield a concentration of 10,000  $\mu\text{G}/\text{mL}$ . A 2.0 mL volume of the 10,000  $\mu\text{G}/\text{mL}$  solution is then diluted to 10 mL with methylene chloride to yield a 2000  $\mu\text{G}/\text{mL}$  concentration. Several compounds may be combined into one 2000  $\mu\text{G}/\text{mL}$  stock solution. Prepared stocks are stored tightly sealed at  $-18^\circ \pm 5^\circ\text{C}$  and expire one year after the preparation date. Any working solutions generated from the stock are assigned the same expiration date as the stock. An example of a set of stock standards that can be used is listed below:

SV Calibration Mix#1(Restek #31007)	2000 $\mu\text{G}/\text{mL}$
SV Calibration Mix#2(Restek #31008)	2000 $\mu\text{G}/\text{mL}$
SV Calibration Mix#3(Restek #31009)	2000 $\mu\text{G}/\text{mL}$
SV Calibration Mix#4(Restek #31010)	2000 $\mu\text{G}/\text{mL}$
SV Calibration Mix#5(Restek #31011)	2000 $\mu\text{G}/\text{mL}$
SV Calibration Mix#6(Restek #31012)	2000 $\mu\text{G}/\text{mL}$
SV Calibration Mix#7(Restek #31013)	2000 $\mu\text{G}/\text{mL}$

6.3.3 **Working Calibration Standards** - A working calibration solution at a concentration of 160  $\mu\text{G}/\text{mL}$  can be prepared by combining 160  $\mu\text{L}$  of each 2000  $\mu\text{G}/\text{mL}$  stock standards and 80  $\mu\text{L}$  of the 4000  $\mu\text{G}/\text{mL}$  surrogate solution and adding the appropriate volume of methylene chloride to give a final volume of 2.0 mL. This working solution is stored tightly sealed at  $-18^\circ \pm 5^\circ\text{C}$  and expires six months after the preparation date of the stock standard that was prepared earliest.

Preparation of calibration standards is performed by diluting a volume of the 160 µG/mL working calibration solution with methylene chloride as in the following example. The exact dilution protocol and resulting concentrations may vary from this example. However, the standard preparation technique is always documented in the instrument logbooks.

<u>Cal. Level</u>	<u>Vol. of Cal. Sol.</u>	<u>Vol. of Methylene Chloride</u>	<u>Final Concentration*</u>
1	6.25 µL	993.75 µL	1.0 µG/mL
2	62.5 µL	937.5 µL	10.0 µG/mL
3	125 µL	875 µL	20 µG/mL
4	250 µL	750 µL	40 µG/mL
5	500 µL	500 µL	80 µG/mL
6	750 µL	250 µL	120 µG/mL
7	1000 µL	0 µL	160 µG/mL

\*For a 1.0 µL injection

A volume of 4.0 µL of internal standard at 2000 µG/mL is added to the 100 µL volume of each calibration standard.

Instrument Calibration: For initial instrument calibration, 1.0 µL of each of the initial calibration standards specified above is analyzed.

Calibration Verification: Following initial calibration, an 80 µG/sample standard prepared from a separate source of calibration standards is analyzed to verify the initial calibration. Concentrations of compounds for the 80 µG/sample standard should fall between 56 µG/sample and 104 µG/sample.

6.4 **Daily Calibration Check Standards** - An 80 µG standard is analyzed at the start of every shift immediately after the DFTPP tune check. When required by specific projects, an end check is also performed.

The system performance check compounds (SPCC) must yield a minimum relative response factor of 0.050. The SPCCs include:

- n,n-Nitroso-di-n-propylamine
- Hexachlorocyclopentadiene
- 2,4-Dinitrophenol
- 4-Nitrophenol

Poor response of any of the SPCC compounds is indicative of active sites in the chromatographic system. Corrective action such as injection port liner replacement or removal of the first meter of the capillary column must be undertaken until the system is capable of meeting the minimum relative response factor.

The relative response factor for the 12 continuing calibration compounds (CCC) for the daily calibration and end check standards are compared to that of the original six point calibration. The check is performed to validate the use of the original calibration. The percent difference of the CCCs cannot exceed ±30 % of the original six point or the initial calibration is re-analyzed.

$$\% \text{ Difference} = ((RRF_1 - RRF_C) / RRF_1) \times 100$$

Where: RRF<sub>1</sub> = Average relative response factor from the initial calibration curve  
RRF<sub>C</sub> = Relative response factor from the daily calibration check

As is noted in the discussion of calibration criteria (section 6.3.1), when the target compound list includes PAHs only, the PAH recoveries are evaluated instead of the CCCs. Therefore, for the daily calibration check, the %D criteria for the PAH RRFs is  $\pm 30\%$  of the original six point. If the RRF exceeds this criteria for any particular compound, but that compound was not detected in any of the associated samples, then the data can be reported. Otherwise, the instrument needs to be re-calibrated and samples re-analyzed.

The RRF of all compounds detected in a sample must not exceed  $\pm 50\%$  difference from their average RRF in the initial calibration curve. Should a sample contain a compound that exceeds this criteria, the sample will be re-analyzed after either a new calibration curve has been performed or a calibration check is analyzed and meets the above criteria.

- 6.5 **Surrogate Percent Recovery Acceptance Criteria** - Surrogates are spiked into all samples and blanks prior to extraction. Acceptance criteria are generally taken from EPA Method 8270 for low/medium level soils. Those criteria are given below. It should be noted that EPA Method TO-13 is validated only for neutral PAHs. Acid extraction criteria are not followed in this method and consequently the recovery of 8270 acid compounds will be generally low.

<u>Surrogate</u>	<u>% Recovery</u>
Nitrobenzene-d <sub>5</sub>	23-120
2-Fluorobiphenyl	30-115
p-Terphenyl-d <sub>14</sub>	18-137
Phenol-d <sub>5</sub>	24-113
2-Fluorophenol	25-121
2,4,6-Tribromophenol	19-122

If surrogate recoveries exceed these limits, the analyst will re-aliquot and re-analyze the extract. It is not possible to re-extract PUF samples. If the surrogate recoveries are within limits in the re-analysis, the second analysis will be reported. If the surrogate recoveries are out of limits a second time, the sample will be reported with a narrative indicating the acceptance criteria for surrogate recoveries were exceeded.

- 6.6 The method analysis sequence is as follows and repeats every 12 hours:

Initial 12 hour period:	DFTPP Tune Check Multipoint Calibration Curve Reagent Blank Initial Calibration Verification Samples (including method blanks and spikes as applicable) End Calibration Check (when required)
Subsequent 12 hour period:	DFTPP Tune Check CCC Check Samples (including method blanks and spikes as applicable) End Calibration Check (when required)

The "Subsequent 12 hour" sequence is followed each 12 hour period that samples are analyzed, until the system is found to be out of calibration.

6.7 **Reporting Limits** - Reporting limits are determined by spiking the compounds onto blank cartridges and using the same procedures used for sample analysis. Our reporting limits are verified by analysis of a standard at the reporting limit each time the instrument is calibrated. In general, the reporting limits possible under full scan GC/MS are 1 µG/sample for most compounds and 5 µG/sample for the acids. Lower reporting limits may be arranged on a project specific basis taking into account the specific analytes and the results the most recent laboratory MDL study.

An annual MDL study (analysis of seven replicate method spikes near the reporting limit) is performed to verify our ability to detect target compounds at or below the reporting limits, noted in Table 1. Results of these studies are maintained in the laboratory files.

6.8 **Laboratory Control Spike (LCS)** - A 100 µG LCS is spiked and extracted with each set of samples extracted. The compounds spiked and the associated acceptance criteria are noted below.

<u>Compound</u>	<u>% Recovery Limits</u>
Phenol	26 - 90
2-Chlorophenol	25 - 102
1,4-Dichlorobenzene	28 - 104
n-Nitroso-di-n-propylamine	41 - 126
1,2,4-Trichlorobenzene	38 - 107
4-Chloro-3-methylphenol	26 - 103
Acenaphthene	31 - 137
4-Nitrophenol	11 - 114
2,4-Dinitrotoluene	28 - 89
Pentachlorophenol	17 - 109
Pyrene	35 - 142

If an LCS exceeds these limits, the analyst will re-aliquot and re-analyze the extract. It is not possible to re-extract PUF samples. If the LCS recoveries are within limits in the re-analysis, the second analysis will be reported. If the LCS recoveries are out of limits a second time, the samples will be reported with a narrative indicating the acceptance limits were exceeded for the associated LCS.

## 7.0 CALCULATIONS

Response Factors:

$$\text{Relative Response Factor (RRF)} = \frac{\text{Area of Compound}}{\text{Area of Internal Std.}} \times \frac{\text{Concentration of Int. Std. (nG)}}{\text{Concentration of Compound (nG)}}$$

Results Calculation:

$$\text{nG On Column} = \frac{\text{Area of Compound in Sample}}{\text{Area of Int. Std. in Sample}} \times \frac{\text{Concentration of Int. Std. (nG)}}{\text{Average RRF from Initial Cal. Curve}}$$

$$\mu\text{G/Sample} = \frac{\text{nG On Column}}{1.0 \mu\text{L Inj. Vol.}} \times 0.50 \text{ mL Final Volume} \times \text{Dilution Factor}$$

Table I. Semivolatile Organic GC/MS Tuning and Mass Calibration -  
Decafluorotriphenylphosphine (DFTPP)

Exhibit I. TO-13/8270 Compounds and Primary Ions

Table I.  
SEMIVOLATILE ORGANIC  
GC/MS TUNING AND MASS CALIBRATION  
Decafluorotriphenylphosphine (DFTPP)

m/e	ION ABUNDANCE CRITERIA
51	30.0 - 60.0% of mass 198
68	Less than 2.0% of mass 69
69	Mass 69 relative abundance
70	Less than 2.0% of mass 69
127	40.0 - 60.0% of mass 198
197	Less than 1.0% of mass 198
198	Base Peak, 100% relative abundance
199	5.0 - 9.0% of mass 198
275	10.0 - 30.0% of mass 198
365	Greater than 1.00% of mass 198
441	Present, but less than mass 443
442	Greater than 40.0% of mass 198
443	17.0 - 23.0% of mass 442

**Exhibit I.**

**TO-13/8270 Compounds and Primary Ions**

Air Toxics Limited

COMPOUND LISTING

Method file : /chem/msdh.i/h-13Aug97.b/BNA-072597.m  
 Quant Method : ISTD Target Version : 3.12  
 Last Update : 13-Aug-1997 09:05 Number of Cpnds : 103  
 Data Type : MS DATA

Global Integrator : HP RTE

Chromat Events	Values
-----	-----
Initial:Thresh Units	1.000000
Initial:Area Thresh	5.000000
Initial:Max Peaks	100.000000
Initial:Bunching	1.000000
Initial:Smoothing	0.000000
Initial:Start Thresh	0.200000
Initial:Stop Thresh	0.000000
Initial:Baseline Reset	5.000000
Initial:Set Valley	100.000000

Compound	RT	RT Window	RF	Mass
\$ 1 2-Fluorophenol	5.057	4.057-6.057	0.800	112.00
	5.057	4.057-6.057	0.000	64.00
	5.057	4.057-6.057	0.000	92.00
\$ 129 d4-2,4-dichlorophenol	10.816	9.816-11.816	0.000	165.00
\$ 2 Phenol-d5	6.742	5.742-7.742	0.369	99.00
	6.742	5.742-7.742	0.000	71.00
	6.775	5.775-7.775	0.896	94.00
3 Phenol	6.775	5.775-7.775	0.000	66.00
	6.775	5.775-7.775	0.000	65.00
	6.971	5.971-7.971	0.740	93.00
4 bis(2-Chloroethyl)ether	6.971	5.971-7.971	0.000	63.00
	6.971	5.971-7.971	0.000	95.00
	7.053	6.053-8.053	0.711	128.00
5 2-Chlorophenol	7.053	6.053-8.053	0.000	130.00
	7.053	6.053-8.053	0.000	64.00
	7.364	6.364-8.364	0.778	146.00
6 1,3-Dichlorobenzene	7.364	6.364-8.364	0.000	148.00
	7.364	6.364-8.364	0.000	113.00
	7.478	6.478-8.478	34317	150.00
* 7 1,4-Dichlorobenzene-d4	7.478	6.478-8.478	0.000	152.00
	7.478	6.478-8.478	0.000	115.00
	7.527	6.527-8.527	0.797	146.00
8 1,4-Dichlorobenzene	7.527	6.527-8.527	0.000	148.00
	7.511	6.511-8.511	0.000	113.00

## Air Toxics Limited

## COMPOUND LISTING

Method file : /chem/msdh.i/h-13Aug97.b/BNA-072597.m

Compound	RT	RT Window	RF	Mass
9 1,2-Dichlorobenzene	7.822	6.822-8.822	0.740	146.00
	7.822	6.822-8.822	0.000	148.00
	7.822	6.822-8.822	0.000	113.00
10 2-Methylphenol	8.002	7.002-9.002	0.619	108.00
	8.002	7.002-9.002	0.000	107.00
	8.002	7.002-9.002	0.000	79.00
11 bis(2-Chloroisopropyl) ethe	8.067	7.067-9.067	0.917	45.00
	8.116	7.116-9.116	0.176	121.00
12 4-Methylphenol	8.361	7.361-9.361	0.633	108.00
	8.361	7.361-9.361	0.000	107.00
	8.361	7.361-9.361	0.000	79.00
13 N-Nitrosodipropylamine	8.394	7.394-9.394	0.442	70.00
	8.394	7.394-9.394	0.000	130.00
	8.394	7.394-9.394	0.000	101.00
14 Hexachloroethane	8.541	7.541-9.541	0.347	117.00
	8.541	7.541-9.541	0.000	201.00
	8.541	7.541-9.541	0.000	199.00
\$ 15 Nitrobenzene-d5	8.656	7.656-9.656	0.720	82.00
	8.656	7.656-9.656	0.000	54.00
	8.672	7.672-9.672	0.000	128.00
16 Nitrobenzene	8.705	7.705-9.705	0.372	77.00
	8.705	7.705-9.705	0.000	123.00
	8.705	7.705-9.705	0.000	65.00
17 Isophorone	9.261	8.261-10.261	0.643	82.00
	9.261	8.261-10.261	0.000	138.00
	9.261	8.261-10.261	0.000	95.00
18 2,4-Dimethylphenol	9.523	8.523-10.523	0.238	122.00
	9.523	8.523-10.523	0.000	107.00
	9.523	8.523-10.523	0.000	121.00
19 2-Nitrophenol	9.408	8.408-10.408	0.183	139.00
	9.408	8.408-10.408	0.000	65.00
	9.408	8.408-10.408	0.000	109.00
20 Benzoic Acid	9.915	8.915-10.915	0.153	122.00
	9.915	8.915-10.915	0.000	105.00
	9.915	8.915-10.915	0.000	77.00
21 bis(2-Chloroethoxy) methane	9.752	8.752-10.752	0.381	93.00
	9.752	8.752-10.752	0.000	123.00
	9.752	8.752-10.752	0.000	95.00
22 2,4-Dichlorophenol	9.964	8.964-10.964	0.251	162.00
	9.964	8.964-10.964	0.000	164.00
	9.964	8.964-10.964	0.000	98.00

## Air Toxics Limited

## COMPOUND LISTING

Method file : /chem/msdh.i/h-13Aug97.b/BNA-072597.m

Compound	RT	RT Window	RF	Mass
23 1,2,4-Trichlorobenzene	10.144	9.144-11.144	0.308	180.00
	10.144	9.144-11.144	0.000	182.00
	10.144	9.144-11.144	0.000	145.00
* 24 Naphthalene-d8	10.275	9.275-11.275	70718	136.00
	10.275	9.275-11.275	0.000	68.00
25 Naphthalene	10.324	9.324-11.324	0.891	128.00
	10.324	9.324-11.324	0.000	129.00
	10.324	9.324-11.324	0.000	127.00
26 4-Chloroaniline	10.455	9.455-11.455	0.205	127.00
	10.455	9.455-11.455	0.000	129.00
27 Hexachlorobutadiene	10.602	9.602-11.602	0.185	225.00
	10.602	9.602-11.602	0.000	223.00
	10.602	9.602-11.602	0.000	227.00
28 4-Chloro-3-Methylphenol	11.616	10.616-12.616	0.262	107.00
	11.616	10.616-12.616	0.000	142.00
	11.616	10.616-12.616	0.000	144.00
29 2-Methylnaphthalene	11.944	10.944-12.944	0.560	142.00
	11.944	10.944-12.944	0.000	141.00
30 Hexachlorocyclopentadiene	12.320	11.320-13.320	0.307	237.00
	12.320	11.320-13.320	0.000	272.00
	12.320	11.320-13.320	0.000	235.00
31 2,4,6-Trichlorophenol	12.631	11.631-13.631	0.333	196.00
	12.631	11.631-13.631	0.000	198.00
	12.631	11.631-13.631	0.000	200.00
32 2,4,5-Trichlorophenol	12.696	11.696-13.696	0.354	196.00
	12.696	11.696-13.696	0.000	198.00
	12.696	11.696-13.696	0.000	200.00
\$ 33 2-Fluorobiphenyl	12.843	11.843-13.843	0.601	172.00
	12.843	11.843-13.843	0.000	171.00
34 2-Chloronaphthalene	13.105	12.105-14.105	0.917	162.00
	13.105	12.105-14.105	0.000	164.00
	13.105	12.105-14.105	0.000	127.00
35 2-Nitroaniline	13.367	12.367-14.367	0.318	65.00
	13.383	12.383-14.383	0.000	138.00
	13.383	12.383-14.383	0.000	92.00
36 Dimethylphthalate	13.874	12.874-14.874	1.112	163.00
	13.874	12.874-14.874	0.000	194.00
	13.874	12.874-14.874	0.000	164.00
37 2,6-Dinitrotoluene	14.005	13.005-15.005	0.281	165.00
	14.005	13.005-15.005	0.000	89.00
	14.005	13.005-15.005	0.000	121.00

## Air Toxics Limited

## COMPOUND LISTING

Method file : /chem/msdh.i/h-13Aug97.b/BNA-072597.m

Compound	RT	RT Window	RF	Mass
38 Acenaphthylene	14.086	13.286-14.886	1.507	152.00
	14.086	13.286-14.886	0.000	151.00
	14.086	13.286-14.886	0.000	153.00
39 3-Nitroaniline	15.869	14.869-16.869	0.105	138.00
	14.526	13.526-15.526	0.000	92.00
	14.575	13.575-15.575	0.000	108.00
* 40 Acenaphthene-d10	14.446	13.446-15.446	39042	164.00
	14.446	13.446-15.446	0.000	162.00
	14.446	13.446-15.446	0.000	160.00
41 Acenaphthene	14.512	13.512-15.512	0.886	154.00
	14.512	13.512-15.512	0.000	152.00
	14.512	13.512-15.512	0.000	153.00
42 2,4-Dinitrophenol	14.642	13.642-15.642	0.163	184.00
	14.626	13.626-15.626	0.000	63.00
	14.642	13.642-15.642	0.000	154.00
43 4-Nitrophenol	14.839	13.839-15.839	0.157	109.00
	14.839	13.839-15.839	0.000	139.00
	14.839	13.839-15.839	0.000	65.00
44 2,4-Dinitrotoluene	14.953	13.953-15.953	0.366	165.00
	14.937	13.937-15.937	0.000	63.00
	14.953	13.953-15.953	0.000	182.00
45 Dibenzofuran	14.937	13.937-15.937	1.330	168.00
	14.937	13.937-15.937	0.000	139.00
46 Diethylphthalate	15.591	14.591-16.591	1.187	149.00
	15.591	14.591-16.591	0.000	177.00
	15.591	14.591-16.591	0.000	150.00
47 4-Chlorophenyl phenyl ethe	15.804	14.804-16.804	0.571	204.00
	15.804	14.804-16.804	0.000	206.00
	15.804	14.804-16.804	0.000	141.00
48 4-Nitroaniline	15.869	14.869-16.869	0.157	138.00
	15.869	14.869-16.869	0.000	92.00
	15.869	14.869-16.869	0.000	108.00
49 Fluorene	15.771	14.771-16.771	1.028	166.00
	15.771	14.771-16.771	0.000	165.00
	15.771	14.771-16.771	0.000	167.00
50 4,6-Dinitro-2-methylphenol	15.935	14.935-16.935	0.115	198.00
	15.935	14.935-16.935	0.000	121.00
	15.935	14.935-16.935	0.000	51.00
51 N-nitrosodiphenylamine	16.098	15.098-17.098	0.313	169.00
	16.098	15.098-17.098	0.000	168.00
	16.098	15.098-17.098	0.000	167.00

## Air Toxics Limited

## COMPOUND LISTING

Method file : /chem/msdh.i/h-13Aug97.b/BNA-072597.m

Compound	RT	RT Window	RF	Mass
\$ 52 2,4,6-Tribromophenol	16.344	15.344-17.344	0.116	330.00
	16.344	15.344-17.344	0.000	332.00
	16.344	15.344-17.344	0.000	141.00
53 4-Bromophenyl phenyl ether	16.982	15.982-17.982	0.190	248.00
	16.982	15.982-17.982	0.000	250.00
	16.982	15.982-17.982	0.000	141.00
	16.982	15.982-17.982	0.000	141.00
54 Hexachlorobenzene	17.096	16.096-18.096	0.245	284.00
	17.080	16.080-18.080	0.000	142.00
	17.096	16.096-18.096	0.000	249.00
55 Pentachlorophenol	17.587	16.587-18.587	0.133	266.00
	17.587	16.587-18.587	0.000	264.00
	17.587	16.587-18.587	0.000	268.00
* 56 Phenanthrene-d10	18.045	17.045-19.045	71681	188.00
	18.028	17.028-19.028	0.000	94.00
	18.028	17.028-19.028	0.000	80.00
57 Phenanthrene	18.094	17.094-19.094	0.864	178.00
	18.094	17.094-19.094	0.000	176.00
	18.094	17.094-19.094	0.000	179.00
58 Anthracene	18.208	17.208-19.208	0.816	178.00
	18.208	17.208-19.208	0.000	176.00
	18.208	17.208-19.208	0.000	179.00
59 Di-n-butylphthalate	19.566	18.566-20.566	1.029	149.00
	19.566	18.566-20.566	0.000	150.00
	19.566	18.566-20.566	0.000	104.00
60 Fluoranthene	20.973	19.973-21.973	0.958	202.00
	20.956	19.956-21.956	0.000	101.00
	20.956	19.956-21.956	0.000	100.00
61 Pyrene	21.512	20.512-22.512	0.966	202.00
	21.496	20.496-22.496	0.000	101.00
	21.496	20.496-22.496	0.000	100.00
\$ 62 Terphenyl-d14	21.954	20.954-22.954	0.661	244.00
	21.954	20.954-22.954	0.000	122.00
	21.954	20.954-22.954	0.000	212.00
63 3 3'-Dichlorobenzidine	24.408	23.408-25.408	0.146	252.00
	24.408	23.408-25.408	0.000	254.00
	24.408	23.408-25.408	0.000	126.00
64 Butyl benzyl phthalate	23.197	22.197-24.197	0.432	149.00
	23.197	22.197-24.197	0.000	91.00
	23.197	22.197-24.197	0.000	206.00
65 bis(2-ethylhexyl) Phthalate	24.637	23.637-25.637	0.610	149.00
	24.637	23.637-25.637	0.000	167.00
	24.637	23.637-25.637	0.000	279.00

## Air Toxics Limited

## COMPOUND LISTING

Method file : /chem/msdh.i/h-13Aug97.b/BNA-072597.m

Compound	RT	RT Window	RF	Mass
66 Benzo(a)Anthracene	24.424	23.424-25.424	0.918	228.00
	24.424	23.424-25.424	0.000	229.00
	24.424	23.424-25.424	0.000	226.00
* 67 Chrysene-d12	24.473	23.473-25.473	72769	240.00
	24.473	23.473-25.473	0.000	236.00
	24.457	23.457-25.457	0.000	120.00
68 Chrysene	24.522	23.522-25.522	0.819	228.00
	24.522	23.522-25.522	0.000	226.00
	24.522	23.522-25.522	0.000	229.00
69 Di-n-octyl phthalate	26.125	25.125-27.125	1.160	149.00
	26.125	25.125-27.125	0.000	150.00
70 Benzo(b)fluoranthene	26.845	25.845-27.845	0.999	252.00
	26.845	25.845-27.845	0.000	253.00
	26.845	25.845-27.845	0.000	125.00
71 Benzo(k)fluoranthene	26.927	25.927-27.927	0.984	252.00
	26.927	25.927-27.927	0.000	253.00
	26.910	25.910-27.910	0.000	125.00
* 72 Perylene-d12	27.695	26.695-28.695	66404	264.00
	27.695	26.695-28.695	0.000	260.00
	27.695	26.695-28.695	0.000	265.00
73 Indeno(1,2,3-cd)pyrene	30.492	28.492-32.492	0.808	276.00
	30.492	28.492-32.492	0.000	138.00
	30.492	28.492-32.492	0.000	227.00
74 Benzo(a)pyrene	27.548	26.548-28.548	0.849	252.00
	27.548	26.548-28.548	0.000	253.00
	27.548	26.548-28.548	0.000	125.00
75 Dibenzo(a,h)anthracene	30.574	28.574-32.574	0.765	278.00
	30.574	28.574-32.574	0.000	279.00
	30.574	28.574-32.574	0.000	139.00
76 Benzo(g,h,i)perylene	31.359	30.359-32.359	0.847	276.00
	31.343	30.343-32.343	0.000	138.00
	31.359	30.359-32.359	0.000	277.00
77 N-nitrosodimethylamine	9.150	8.150-10.150	0.000	74.00
	9.150	8.150-10.150	0.000	42.00
78 3-Methylphenol	18.778	17.778-19.778	0.000	108.00
	18.778	17.778-19.778	0.000	107.00
	18.778	17.778-19.778	0.000	79.00
79 Cumene	16.729	15.729-17.729	0.000	105.00
	16.729	15.729-17.729	0.000	120.00
80 3,3'-Dimethoxybenzidine	32.647	31.647-33.647	0.000	244.00
	32.647	31.647-33.647	0.000	201.00
	32.647	31.647-33.647	0.000	79.00

## Air Toxics Limited

## COMPOUND LISTING

Method file : /chem/msdh.i/h-13Aug97.b/BNA-072597.m

Compound	RT	RT Window	RF	Mass	
81 Bicyclo[2.2.1]hepta-2,5-di	13.364	12.364-14.364	0.000	91.00	
	13.364	12.364-14.364	0.000	66.00	
	13.364	12.364-14.364	0.000	92.00	
82 Dicyclopentadiene	18.298	17.298-19.298	0.000	66.00	
	18.298	17.298-19.298	0.000	132.00	
	18.298	17.298-19.298	0.000	39.00	
\$ 83 1-Methylnaphthalene-d10	12.091	11.091-13.091	0.496	152.00	
	12.091	11.091-13.091	0.000	122.00	
	12.091	11.091-13.091	0.000	150.00	
84 Benzo(e)pyrene	27.417	26.417-28.417	1.016	252.00	
	27.417	26.417-28.417	0.000	125.00	
	27.417	26.417-28.417	0.000	250.00	
\$ 123 Benzo(e)pyrene-d12	28.331	27.331-29.331	0.000	264.00	
	112 Biphenyl	17.402	16.402-18.402	0.000	154.00
		17.402	16.402-18.402	0.000	76.00
118 Diethyl Ether	17.402	16.402-18.402	0.000	153.00	
	17.450	16.450-18.450	0.000	100.00	
	13.349	12.349-14.349	0.000	93.00	
113 Aniline	13.349	12.349-14.349	0.000	66.00	
	114 2-Methyl-benzenamine	14.775	13.775-15.775	0.000	106.00
14.775		13.775-15.775	0.000	107.00	
115 N,N-Dimethyl-benzenamine	15.037	14.037-16.037	0.000	120.00	
	15.037	14.037-16.037	0.000	121.00	
	15.037	14.037-16.037	0.000	77.00	
116 2,4-Dimethylbenzenamine	16.086	15.086-17.086	0.000	121.00	
	16.086	15.086-17.086	0.000	120.00	
	16.086	15.086-17.086	0.000	106.00	
117 N,N,4-Trimethylbenzenamine	16.299	15.299-17.299	0.000	134.00	
	16.299	15.299-17.299	0.000	135.00	
	16.299	15.299-17.299	0.000	119.00	
\$ 119 Fluoranthene-d0	21.409	20.409-22.409	0.685	212.00	
	21.409	20.409-22.409	0.000	106.00	
\$ 120 Benzo(a)pyrene-d12	28.952	27.952-29.952	0.000	264.00	
	28.952	27.952-29.952	0.000	132.00	
124 Benzyl Alcohol	7.789	6.789-8.789	0.442	108.00	
	7.789	6.789-8.789	0.000	79.00	
	7.789	6.789-8.789	0.000	77.00	
125 Lindane	19.752	18.752-20.752	0.000	183.00	
	19.752	18.752-20.752	0.000	181.00	
	19.752	18.752-20.752	0.000	109.00	

## Air Toxics Limited

## COMPOUND LISTING

Method file : /chem/msdh.i/h-13Aug97.b/BNA-072597.m

Compound	RT	RT Window	RF	Mass
126 Dieldrin	24.070	23.070-25.070	0.000	79.00
	24.070	23.070-25.070	0.000	263.00
	24.070	23.070-25.070	0.000	279.00
127 4,4'-DDD	24.675	23.675-25.675	0.000	235.00
	24.675	23.675-25.675	0.000	237.00
	24.675	23.675-25.675	0.000	165.00
128 4,4'-DDT	25.411	24.411-26.411	0.000	235.00
	25.411	24.411-26.411	0.000	237.00
	25.411	24.411-26.411	0.000	165.00
\$ 130 13c-Pentachlorophenol	18.455	17.455-19.455	0.000	272.00
\$ 131 d10-Anthracene	19.044	18.044-20.044	0.000	188.00
\$ 132 d12-Benzo(a)pyrene	28.070	27.070-29.070	0.754	264.00

**CARB 100**

California Environmental Protection Agency



Method 100

Procedures for Continuous Gaseous  
Emission Stack Sampling

Adopted: June 29, 1983

Amended: July 28, 1997

Method 100

Table of Contents

	<u>Page</u>
<b>1 OVERVIEW</b> .....	1
1.1 PRINCIPLE .....	1
1.2 APPLICABILITY .....	1
1.3 SAFETY .....	1
1.4 ALTERNATIVE TEST PROCEDURES .....	1
1.5 DEFINITIONS .....	2
1.6 SOURCE TEST PERFORMANCE SPECIFICATIONS .....	3
<b>2 EQUIPMENT</b> .....	3
2.1 SAMPLE TRANSFER SYSTEM .....	3
2.2 GAS ANALYZERS AND DATA ACQUISITION .....	4
2.3 MEASUREMENT OF STACK FLOWRATE, MOISTURE, AND OTHER PARAMETERS .....	5
<b>3 CALIBRATION GASES</b> .....	6
3.1 CALIBRATION GASES .....	6
3.2 GAS DILUTION SYSTEM .....	7
<b>4 ON-SITE PREPARATION FOR SAMPLING</b> .....	7
4.1 CLEANING/ASSEMBLY OF SAMPLE TRAIN .....	7
4.2 CALIBRATION OF CONTINUOUS ANALYZERS .....	7
4.3 PRETEST LEAK CHECK .....	7
4.4 SAMPLE SYSTEM BIAS CHECK .....	8
4.5 DETERMINATION OF SAMPLING TRAVERSE POINTS .....	8
<b>5 SAMPLE COLLECTION</b> .....	8

**Table of Contents (con't)**

**6 POST TEST PERFORMANCE CHECKS** ..... 8

6.1 ZERO AND CALIBRATION DRIFT ..... 9

6.2 SAMPLING SYSTEM BIAS ..... 9

**7 CALCULATIONS** ..... 10

7.1 POLLUTANT CONCENTRATION ..... 10

7.2 MASS EMISSION RATE ..... 10

7.3 POLLUTANT CONCENTRATION FOR 12% CO<sub>2</sub> OR 3% O<sub>2</sub> ..... 11

**TABLE 100.1 GAS ANALYZER SPECIFICATIONS** ..... 12

**FIGURE 100.1 METHOD 100 SAMPLE TRAIN ASSEMBLY** ..... 15

## METHOD 100

### Procedures for Continuous Gaseous Emission Stack Sampling

#### 1 OVERVIEW

##### 1.1 PRINCIPLE

A sample of an exhaust gas stream is extracted, conditioned and analyzed continuously by instruments. The measurements made by the continuous analyzers are used to determine average emission concentrations. By measuring the stack gas flowrate and moisture, and using this information with the average emission concentration, mass emission rates can be determined.

##### 1.2 APPLICABILITY

This method is applicable for determining emissions of oxides of nitrogen, carbon monoxide, carbon dioxide, sulfur dioxide, total hydrocarbons, and oxygen from stationary source flowing gas streams in ducts, stacks and flues. This procedure does not supersede the New Source Performance Standards requirement for permanently installed continuous emissions monitoring instruments.

This test procedure is an alternative method to appropriate U.S. EPA reference methods, in particular, EPA methods 3A, 6C, 7E, 10, and 25A and B. This procedure should be used only on those sources where equivalency to the reference methods has been established or the specific regulations for the source specify this procedure.

##### 1.3 SAFETY

This method does not address the safety problems associated with its use. It is the responsibility of the user of this method to establish appropriate safety and health practices including the safe handling of compressed gases, flammable gases and any hazardous compounds and to determine the applicability of regulatory limitations prior to use of this method.

##### 1.4 ALTERNATIVE TEST PROCEDURES

Any modification of this method beyond those expressly permitted shall be subject to approval by the Executive Officer of the Air Resources Board or his or her authorized representative.

## 1.5 DEFINITIONS

### 1.5.1 Range

The upper limit of the gas concentration measurement range displayed on the data recorder. The range is selected so that the sample gas concentration is between 10 and 95 percent of the range for each pollutant of interest.

### 1.5.2 Calibration Gas

A known concentration of a gas in an inert diluent gas.

### 1.5.3 Analyzer Calibration Error

The difference between the known concentration of a calibration gas and the concentration measured by the gas analyzer when the calibration gas is introduced directly to the gas analyzer.

### 1.5.4 Sampling System Bias

The difference between the concentration measured by a gas analyzer when a known concentration calibration gas is introduced at the sampling probe and when the same gas is introduced directly to the analyzer.

### 1.5.5 Zero Drift

The difference between the concentration measured by the gas analyzer for zero gas before the sample run and the concentration measured by the analyzer for zero gas after a stated period of operation during which no unscheduled maintenance, repair, or adjustment took place.

### 1.5.6 Calibration Drift

The difference between the concentration measured by the gas analyzer for a calibration gas before the sample run and the concentration measured by the analyzer for that same calibration gas after a stated period of operation during which no unscheduled maintenance, repair, or adjustment took place.

### 1.5.7 Response Time

The time required for the data recorder to display 95% of the difference in gas concentration on the data recorder after a step change in gas concentration, such as a switch from zero gas to calibration gas.

### 1.5.8 Interference Check

Determination of the concentration measured for a known concentration of a component in the sample gas other than the target gas component being measured by the gas analyzer.

## 1.6 SOURCE TEST PERFORMANCE SPECIFICATIONS

The following specifications must be met for data from a test run to be considered valid:

- 1.6.1 Analyzer Calibration Error  
±2 percent or less of the range when introducing zero or calibration gas.
- 1.6.2 Zero Drift  
±3 percent or less of the range during a test run.
- 1.6.3 Span Drift  
±3 percent or less of the range during a test run.
- 1.6.4 Sampling System Bias  
±5 percent or less of the range when introducing zero or calibration gas.
- 1.6.5 Interference Check  
For each analyzer, ±5 percent or less of the range.

## 2 EQUIPMENT

### 2.1 SAMPLE TRANSFER SYSTEM

A schematic of the sampling train is shown in Figure 100.1.

- 2.1.1 Probe Nozzle  
Quartz, borosilicate glass, stainless steel, porcelain or aluminum oxide may be used for the probe nozzle.
- 2.1.2 Probe Filter  
An internal or external probe filter may be used. As necessary, provisions should be made for back flushing the filter to remove particulate build-up.
- 2.1.3 Probe  
The probe shall have an inside diameter of 6 mm or larger and shall be constructed of quartz, borosilicate glass, stainless steel, aluminum oxide or porcelain.
- 2.1.4 Sample Line  
The sample line is constructed of teflon or other material which does not absorb or otherwise alter the sample gas.

### 2.1.5 Probe Calibration System

Calibration gases for a sampling system bias check are introduced at the probe. Depending on the configuration of the probe, calibration gas is injected at an internal probe filter, at the probe tip, or directly behind the probe outlet.

### 2.1.6 Sample Conditioner

The sample conditioner shall be capable of reducing the sample gas temperature to 15 °C (60 °F), or to 11 °C (20 °F) lower than the ambient temperature, whichever is lower. All parts of the conditioner exposed to the sample shall be glass, stainless steel or teflon. The sample gas shall not be bubbled or dispersed through the condensate such that minimum contact shall be maintained between any condensate and the sample gas. A temperature gauge shall be used to determine the temperature of the condenser outlet.

If needed, a glass filter is used at the inlet or the outlet of the conditioner to prevent the accumulation of particulate material.

### 2.1.7 Sample System Heaters

If needed to prevent condensation of water or hydrocarbons, or the reaction of other stack constituents, a probe heater may be used. If necessary, use a heated sample line, heated filters, and a heated analyzer. Heaters shall heat the sample to a minimum of 120°C (248°F) or to a temperature above the dewpoint of the target constituent, whichever is greater. Perform no sample conditioning that lowers the sample temperature.

## 2.2 GAS ANALYZERS AND DATA ACQUISITION

### 2.2.1 Specifications

Specifications for the acceptance of gas analyzers for use of Method 100 are listed in Table 100.1. The vendor must provide test data demonstrating that the following performance requirements are met: minimum detection limit, noise level, response time, repeatability, linearity, interference, sensitivity to temperature change, and 24-hour zero and calibration drift limits.

The analyzers shall be housed in a temperature-controlled, vibration-free environment.

### 2.2.2 Carbon Dioxide and Carbon Monoxide

Nondispersive infrared analyzers are acceptable.

### 2.2.3 Oxygen

A paramagnetic analyzer or an electrochemical (fuel cell) analyzer is acceptable.

#### 2.2.4 Total Hydrocarbons

An analyzer using a flame ionization detector (FID) or a nondispersive infrared analyzer (NDIR) is acceptable. Propane or methane is usually used as a span gas. The hydrocarbon species should be characterized prior to the source test to determine that the detector will respond predictably to the organic compounds present. Compound-specific calibration curves must be determined for use of either the FID or the NDIR analyzer to measure specific organic compounds.

#### 2.2.5 Oxides of Nitrogen

An analyzer using chemiluminescence is acceptable. The NO<sub>2</sub> to NO converter must have at least a 90% efficiency in converting nitrogen dioxide (NO<sub>2</sub>) in the sample gas to nitric oxide (NO). An NO<sub>2</sub> to NO converter is not necessary if data are presented to demonstrate that the NO<sub>2</sub> portion of the exhaust gas is less than 5 percent of the total NO<sub>x</sub> concentration. A low temperature (maximum 350°C) converter must be used when NH<sub>3</sub> is present. A high temperature (650°C) stainless steel converter may be used when no NH<sub>3</sub> is present.

If data are not available to demonstrate that the concentration of NO<sub>2</sub> in the sample gas is less than 5% of the total NO<sub>x</sub> concentration, a test of the efficiency of the NO<sub>2</sub> converter must be conducted prior to each source test.

#### 2.2.6 Sulfur Dioxide

An analyzer using infrared or ultraviolet absorption or fluorescence is acceptable.

#### 2.2.7 Other Analyzers

An analyzer operating by measurement principles not listed in Table 100.1 may be used, if its performance meets the requirements of Table 100.1.

#### 2.2.8 Data Acquisition System/Data Recorder

Provide a permanent record of gas analyzer data using a strip chart recorder. A data logger or other electronic data acquisition system may also be used. Any electronic data acquisition system must be capable of integration at a ten second interval. The strip chart, as well as the data acquisition system, must have a resolution of 0.5 percent of the analyzer range. Data reporting includes the following information: pollutant, source, analyzer range, date, time, zero offsets, person operating instruments, and any other pertinent data.

### 2.3 MEASUREMENT OF STACK FLOWRATE, MOISTURE, AND OTHER PARAMETERS

#### 2.3.1 Stack Gas Flowrate and Moisture Measurement

Stack gas flowrate and moisture content can be determined using equipment specified by ARB Test Methods 1 through 4. Stack gas velocity can be determined from a pitot tube measurement as outlined by Methods 1 and 2. Two possible alternatives are:

- (1) A simultaneous traverse of stack gas concentration and velocity,

- (2) A pre and a post test velocity traverse. (Repeat the velocity traverse whenever aware of a change in process conditions which may affect emissions.)

**Note:** If the pitot tube and the sampling probe are used in combination in a testing assembly, care must be taken that any aerodynamic effects on the pitot tube are eliminated. Otherwise, the pitot tube must be calibrated with the other components of the test assembly in place. (See ARB Method 2, Section 4.1.1.)

Alternate methods of flowrate measurement, including consideration of fuel rate, combustion stoichiometry and oxygen concentration in the stack gas and applicable F-factors listed in 40 CFR Part 60 Appendix A, Method 19, must be approved by the Executive Officer of the Air Resources Board or his or her authorized representative.

### 2.3.2 Barometer

A mercury, aneroid, or other barometer capable of measuring atmospheric pressure to within 2.5 mm Hg. shall be used.

### 2.3.3 Vacuum Gauge or Flowmeter

Use a vacuum gauge or a flowmeter for leak check of the sampling train.

## 3 CALIBRATION GASES

### 3.1 Calibration Gases

The calibration gases must be certified according to EPA Traceability Protocol<sup>1</sup>. Alternately the calibration gases must be certified to an analytical accuracy of  $\pm 2$  percent, traceable to a reference material approved by the National Institute of Standards and Technology (NIST), and recertified annually.

Multi-component gas mixtures certified according to EPA Protocol are acceptable. Multi-component gas mixtures which meet the following requirements are also acceptable: the concentration of each component gas must be certified to an analytical accuracy of  $\pm 2$  percent, each component must be traceable to a NIST standard, and the mixture must be recertified semi-annually.

A permeation tube may be used as a calibration standard in place of the calibration gas, provided the following requirements of EPA Method 16 (CFR 60 Appendix A) are met for use of permeation tubes: Section 5.5 for the calibration system, Section 6.5 for the calibration gases, Sections 8.2 and 8.3 on pretest calibration, and Sections 10.2 and 10.3 on post test calibration.

For each pollutant to be measured, use the following three calibration gases:

---

1 "EPA Traceability Protocol for Assay and Certification of Gaseous Calibration Standards, "EPA-600/R93/224, Revised September 1993.

### 3.1.1 High-Range Gas

The concentration should be between 80 and 100 percent of the analyzer range.

### 3.1.2 Mid-range Gas

The concentration should be between 40 and 60 percent of the analyzer range.

### 3.1.3 Zero Gas

Purified air or, if appropriate, nitrogen with a contaminant concentration less than 0.25% of the analyzer range for the appropriate pollutant gas may be used.

## 3.2 GAS DILUTION SYSTEM

A gas dilution system which meets the requirements of EPA Method 205, Verification of Gas Dilution Systems for Field Instrument Calibrations, CFR 40, Part 51, Appendix M, may be used to provide low-level calibration gases from a high-level calibration gas. The calibration gas used with a gas dilution system should be an EPA Protocol gas. A gas dilution system which meets the requirements of EPA Method 205 may be used for all analyzer calibrations and sampling system bias checks.

## 4 ON-SITE PREPARATION FOR SAMPLING

### 4.1 CLEANING/ASSEMBLY OF SAMPLE TRAIN

The sample train may be cleaned prior to being transported to the field. When at the testing site, assemble the cleaned sample train as shown in Figure 100.1.

### 4.2 CALIBRATION OF CONTINUOUS ANALYZERS

Allow analyzers to warm up according to manufacturer's instructions. Adjust system components to achieve the individual analyzer sampling rates recommended by the instrument manufacturer. Alternately introduce zero and calibration gases to the instruments and make all necessary adjustments to calibrate the analyzer and the data recorder.

Conduct the analyzer calibration error check by sequentially introducing the three calibration gases (high-range, mid-range and zero gas) and recording the analyzer response to each calibration gas. Make no adjustments to the sampling/analysis system except those necessary to achieve the proper calibration gas flowrate. The test run will be considered invalid if the analyzer calibration error for any calibration gas exceeds  $\pm 2$  percent of the range. If needed, take corrective action until acceptable performance is achieved.

### 4.3 PRETEST LEAK CHECK

Perform a leak check on the vacuum side of the assembly at the maximum pump vacuum. Correct any leaks found and repeat the leak check and correction procedure until no leak is detected.

#### 4.4 SAMPLE SYSTEM BIAS CHECK

A pretest sampling system bias check is required for each gas analyzer.

Perform the sampling system bias check by alternately introducing at the probe the zero gas and either the high-range or mid-range calibration gas, whichever calibration gas is closest in concentration to the sample gas. Record the gas concentrations displayed by the analyzer. During the sampling system bias check operate the system at the normal sampling rate and make no adjustments to the measurement system other than those necessary to achieve proper calibration gas flow rate. Determine the sampling system response time.

If the difference between the gas concentrations for the analyzer calibration error check and the sample system bias check exceeds  $\pm 5\%$  of the range for either the zero or upscale calibration gas, the bias check is invalid. If needed, take corrective action before repeating the sample system bias check. If the analyzer is adjusted, repeat the analyzer calibration error check before repeating the bias check.

#### 4.5 DETERMINATION OF SAMPLING TRAVERSE POINTS

Select gas sampling traverse points according to the guidelines given in ARB Methods 1 and 2 for velocity traverses. Multipoint gas sampling must be performed unless data are available to demonstrate that the mean pollutant concentration is less than 10% different from that at any single point.

### 5 SAMPLE COLLECTION

Insert the sample probe assembly into the stack and block off the remainder of the sample port opening. Set the probe at the predetermined position and begin data acquisition. If a traverse is required, the sampling time at each traverse point is constant. Sample for at least the sampling system response time plus one minute, allowing enough time for the system to be flushed and the instruments to respond fully. Move probe to next position and repeat. Continue until the stack has been fully traversed.

A test shall include at least three sample runs. Each sample run shall be the length of time specified in the applicable emission limit regulation. As a minimum, the sampling time must be such that the emission test is conducted during representative operating conditions of the source. For a sample run exceeding two hours, conduct sampling system bias checks every two hours. Record performance check data. As necessary, back flush through the probe to prevent particulate build-up on the probe filter. Periodically check the sample conditioner and remove condensate as needed.

If adjustments to the sampling train are necessary during the sample run, conduct a system bias check before any adjustments are made. After any adjustments are made to the analyzer, the analyzer calibration error check shall be conducted. After all adjustments are made to the sampling system, the sampling system bias check shall be performed prior to continuation of the test run.

### 6 POST TEST PERFORMANCE CHECKS

At the end of the sample run, conduct a sampling system bias check for all analyzers. Perform the sampling system bias check by alternately introducing the zero gas and the calibration gas at the probe. During the sampling system check operate the system at the normal sampling rate and make no

adjustments to the measurement system other than those necessary to achieve proper calibration gas flow rates through the sampling system to the gas analyzer.

#### 6.1 ZERO AND CALIBRATION DRIFT

The test run shall be considered invalid if the difference of zero or calibration gas measured for the post run sampling system bias check and zero or calibration gas measured for the initial sampling system bias check of the first test run (Section 4.5) exceeds  $\pm 3$  percent of the range. Use Equation 100-1, below:

$$\text{Drift} = \frac{(c_{ib} - c_{fb})}{r} \times 100$$

Eq. 100 - 1

Where:

$c_{fb}$  = analyzer response for the zero or upscale calibration gas for post run sampling system bias check

$c_{ib}$  = analyzer response for the zero or upscale calibration gas for initial sampling system bias check

$r$  = analyzer range

#### 6.2 SAMPLING SYSTEM BIAS

The test run shall be considered invalid if the difference of zero or calibration gas measured for the post run sampling system bias check and zero or calibration gas measured for the initial analyzer calibration (Section 4.2) exceeds  $\pm 5$  percent of the range. Calculate bias using Equation 100-2:

$$\text{Bias} = \frac{(c_a - c_{fb})}{r} \times 100$$

Eq. 100 - 2

Where:

$c_{fb}$  = analyzer response for the zero or upscale calibration gas for post run sampling system bias check

$c_a$  = analyzer response for the zero or upscale calibration gas for initial analyzer calibration

$r$  = analyzer range

## 7 CALCULATION OF POLLUTANT CONCENTRATION AND MASS EMISSION RATE

### 7.1 POLLUTANT CONCENTRATION

Determine the average concentration,  $C_{gas}$ , of each stack gas constituent using Equation 100-3:

$$C_{gas} = (C_{avg} - C_o) \times \frac{C_{cal}}{(C_{bcal} - C_o)}$$

Eq. 100 - 3

Where:

- $C_{gas}$  = Effluent gas concentration, ppm or % by volume
- $C_{avg}$  = Average gas concentration indicated by gas analyzer, ppm or % by volume
- $C_o$  = Average of initial ( $c_{ib}$ ) and final ( $c_{fb}$ ) system bias responses for zero gas, ppm or % by volume
- $C_{cal}$  = Actual concentration of the calibration gas used for the bias check, ppm or % by volume
- $C_{bcal}$  = Average of initial ( $c_{ib}$ ) and final ( $c_{fb}$ ) sampling system bias responses for the calibration gas, ppm or % by volume

### 7.2 MASS EMISSION RATE

The emission rate in pounds per hour of pollutant is E in Equation 100-4:

$$E = C_{dgas} \times \frac{M}{385 \times 10^6} \times Q \times 60$$

Eq. 100 - 4

Where:

- $C_{dgas}$  = effluent gas concentration corrected to dry basis, ppm
- M = molecular weight in lb/lb-mole
- 385 = standard volume in cubic feet of one lb-mole (at 528° R and 1 atmosphere)
- Q = Stack flowrate in standard dry cubic feet per minute of stack effluents, determined from ARB Methods 2 and 4, or alternative determinations of flow rate and moisture content

7.3 POLLUTANT CONCENTRATION FOR 12% CO<sub>2</sub> OR 3% O<sub>2</sub>

The pollutant concentration C<sub>dgas</sub> is adjusted for 12% CO<sub>2</sub> in Equation 100-5:

$$C_{12\% \text{ CO}_2} = C_{\text{dgas}} \times \frac{12\%}{\% \text{ CO}_2 \text{ during test}}$$

Eq. 100 - 5

For correction to 3% O<sub>2</sub> (using O<sub>2</sub> in air as 20.9%), use Equation 100-6:

$$C_{3\% \text{ O}_2} = C_{\text{dgas}} \times \frac{20.9 - 3.0}{20.9 - \% \text{ O}_2 \text{ during test}}$$

Eq. 100 - 6

**Table 100.1 (page 1 of 3)  
Gas Analyzer Specifications**

	SULFUR DIOXIDE	OXIDES OF NITROGEN	CARBON MONOXIDE	CARBON DIOXIDE	HYDROCARBONS	OXYGEN
Typical Principle of Operation <sup>1</sup>	Ultraviolet or infrared absorption or fluorescence	Chemiluminescence	Infrared absorption	Infrared absorption	Flame ionization or infrared absorption	Paramagnetic or electrochemical cell
Typical Concentration Ranges PPM or % by volume	10 - 2500 ppm	10 - 1000 ppm	10 - 1000 ppm	5 - 20 %	50 ppm - 50%	5 - 25 %
Minimum detection limit, % of full scale for lowest range.	2%	2%	2%	2%	2% as Propane	2%
Noise Level % of range	< ±1%	< ±1%	< ±1%	< ±1%	< ±1%	< ±1%
Response Time to 95% of steady state after a step change in concentration	< 30 secs.	< 30 secs.	< 60 secs.	< 60 secs.	< 30 secs.	< 60 secs.
Repeatability, % of range <sup>3</sup>	1%	1%	1%	1%	1%	1%
Zero Drift after 24 hours of unadjusted continuous operation, % range	< ± 1%	< ± 1%	< ± 1%	< ± 1%	< ± 1%	< ± 1%

<sup>2</sup> Other types will also be acceptable provided that the criteria listed below are met.

<sup>3</sup> 1% of the analyzer range is the maximum absolute difference between replicate results which may be expected with a probability of 95%.

Table 100.1 (page 2 of 3)  
Gas Analyzer Specifications

	SULFUR DIOXIDE	OXIDES OF NITROGEN	CARBON MONOXIDE	CARBON DIOXIDE	HYDROCARBONS	OXYGEN
Span Drift after 24 hours of unadjusted continuous operation, % range	< ± 1%	< ± 1%	< ± 1%	< ± 1%	< ± 1%	< ± 1%
Interference of a component other than the target component measured by the gas analyzer, % of range	< ± 5%	< ± 5%	< ± 5%	< ± 5%	< ± 5%	< ± 5%
Analyzer response to temperature variation <sup>4</sup>	✓	✓	✓	✓	✓	✓
A change in ambient temperature of ± 20° C from 25°C shall not cause a permanent change to the zero or span response of analyzer	✓	✓	✓	✓	✓	✓

<sup>4</sup> When sampling zero or span gas, the analyzer response shall not change more than ± 2% of range when the ambient temperature changes ± 10 °C from 25 °C.

**Table 100.1 (page 3 of 3)  
Gas Analyzer Specifications**

Linearity <sup>5</sup>	SULFUR DIOXIDE	OXIDES OF NITROGEN	CARBON MONOXIDE	CARBON DIOXIDE	HYDROCARBONS	OXYGEN
	< ± 1%	< ± 1%	< ± 1%	< ± 1%	< ± 1%	< ± 1%

<sup>5</sup> Maximum deviation between a mid-range calibration reading and the reading predicted by a straight line drawn between high-range and zero gas calibration points, as a percent of the range.

**FIGURE 100.1**  
**Method 100 Sample Train Assembly**

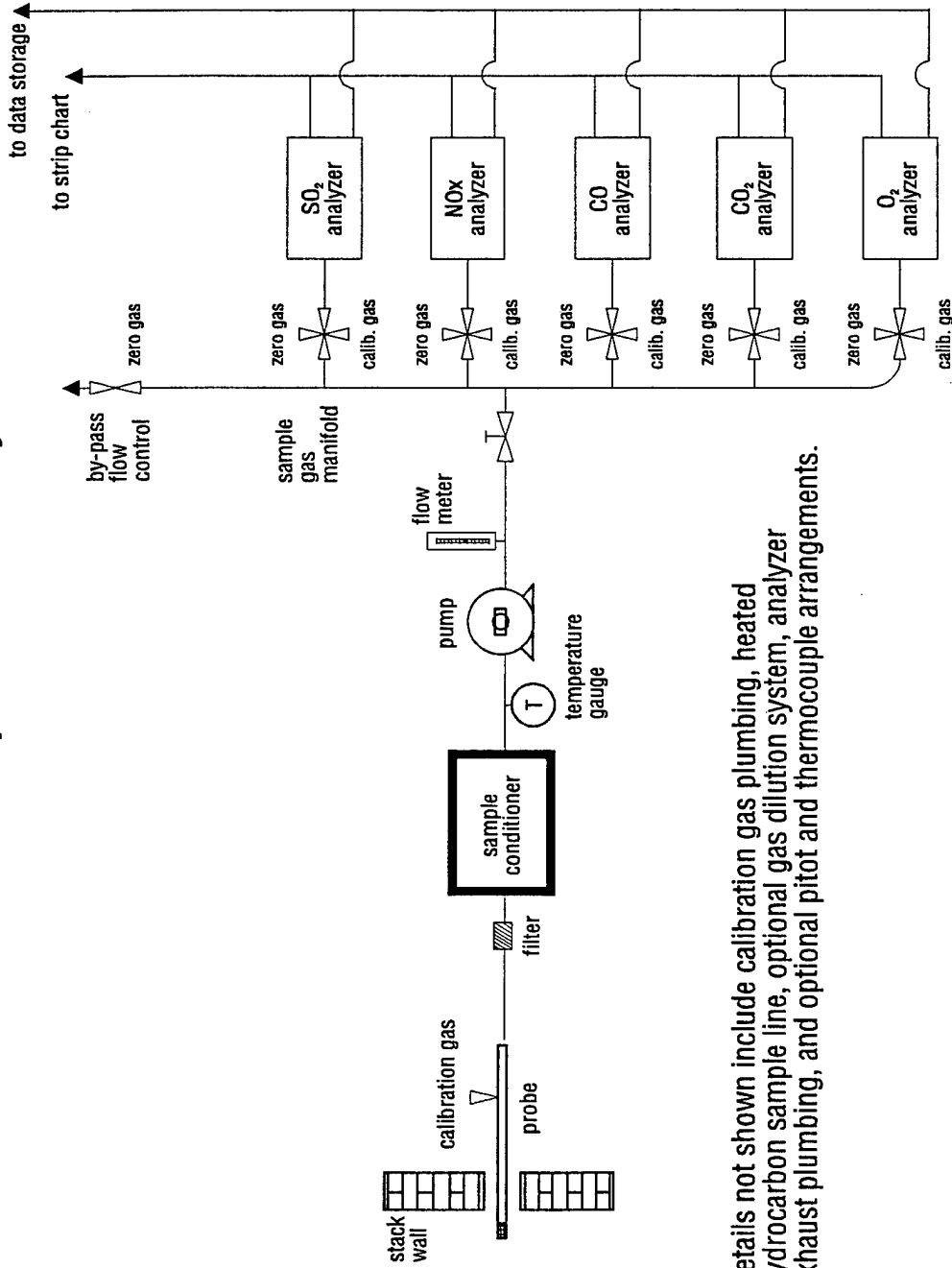

\* Details not shown include calibration gas plumbing, heated hydrocarbon sample line, optional gas dilution system, analyzer exhaust plumbing, and optional pitot and thermocouple arrangements.

**EPA METHOD 9040**

Volume: Wetchemistry  
Section: 5.2  
Page: 1 of 4  
Revision: 4    Number: 1 of 1  
Date: December 21, 1997  
Filename: F:\QC\SOPS\WET\PH.SOP

### pH IN LIQUID AND SOLID SAMPLES

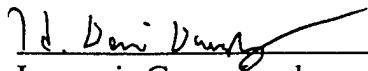
  
\_\_\_\_\_  
Inorganic Group Leader

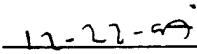
  
\_\_\_\_\_  
Date

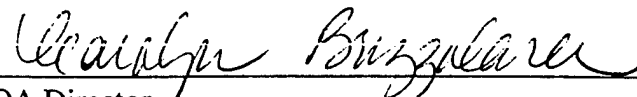
  
\_\_\_\_\_  
QA Director

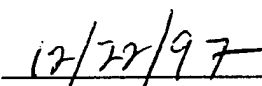
  
\_\_\_\_\_  
Date

Volume: Wetchemistry  
Section: 5.2  
Page: 2 of 4  
Revision: 4 Number: 1 of 1  
Date: December 21, 1997  
Filename: F:\QC\SOPS\WET\PH.SOP

## pH IN LIQUID AND SOLID SAMPLES

**SCOPE:** This SOP covers the determination of pH in a liquid or solid matrix. Electrode range is 2 to 13 pH units.

**REFERENCES:** USEPA SW-846, Method 9040A  
USEPA SW-846, Method 9045A

### QC

**REQUIREMENTS:** The ICV and CCV buffer solution used must be analyzed before sample analysis. The ICV is analyzed for every batch of twenty samples or less and a CCV is analyzed for every ten samples or less. For every batch of twenty samples or less, a sample duplicate is required. The buffer solution should be reanalyzed and recorded after every 20 samples (continuing calibration verification (CCV)).

**QC LIMITS:** The RPD (refer to Appendix 1 for calculation) of the sample/sample duplicate must be <20% for liquid samples and <30% for solid samples. The ICV and CCV buffer solution must be within +/- 0.1 pH units of the true value.

### CORRECTIVE ACTION:

If the RPD or buffer does not pass the criteria specified above, the analysis must be repeated. If the buffer solution criteria is not met, the analysis is suspended until the problem is identified and corrected by recalibrating and analyzing a reference standard that meets specified acceptance criteria. If the CCV is outside the acceptance limits, recalibrate and rerun the samples analyzed since the last passing CCV must be reanalyzed.

### PROCEDURE:

#### *Liquid Samples*

1. Calibrate the pH meter by analyzing three buffers at 4.00, 7.00 and 10.00 pH units. The slope between the three buffers is determined by the instrument

manufacturer and should be between 94 and 103. Record the calibration in the pH laboratory notebook. Use buffer solutions that bracket the expected concentration of the samples being analyzed. Rinse pH probe with DI water between samples. ATC probe compensates for y temperature variance in pH meter.

2. Shake sample and then transfer 10 to 50 ml of sample into a clean beaker. Place a magnetic stir bar in the beaker and place on a magnetic stirrer. Stir at a rate sufficient to provide homogeneity and suspension of any solid material in the sample.
3. Immerse the tip of the electrode completely in the sample. Record the pH (after the instrument reads ready). Rinse the electrodes with DI water between samples. Repeat measurement on successive volumes of sample until values differ by <0.1 pH units. Two or three volume changes are usually sufficient.
4. For any samples whose pH falls into a range not encompassed by the buffer solutions, the instrument must be standardized with the appropriate buffer solution range and the analysis repeated for those samples.

#### *Solid Samples*

5. Calibrate instrument as directed in Step 1 above.
6. Place a small amount of sample onto a spot plate and add several drops of 1:3 HCl to sample. If sample emits bubbles (calcareous), and document it in the becnhbook. Follow Step 7. If the sample does not emit bubbles, Follow Step 8.
7. Transfer 10g of sample into a clean 50-ml beaker, add 20 ml 0.01M CaCl<sub>2</sub> solution and stir the suspensions several times during a 30 minute period. Allow the solution to stand 1 hour until the suspension has settled. Follow Step 3 through 5 as described above.
8. Transfer 20 g of sample into a clean 50-ml beaker. Add 20 ml DI water and stir the suspensions several times during a 30 minute period. Allow the solution to stand 1 hour until the suspension has settled. Follow Step 3 through 5 as described above.

Volume:Wetchemistry  
Section:5.2  
Page:4 of 4  
Revision: 4 Number: 1 of 1  
Date: December 21, 1997  
Filename:F\QC\SOPS\WET\PH.SOP



### LIMS PROCEDURE:

1. Enter job numbers into Analysis Batching menu and record Batch number in log book by:
  - \*Go into LIMS
  - \*Lab Main Menu <end>
  - \*Analysis Batching <end>
  - \*enter: matrix, dept, initials, analysis(pH), status(WIP)
  - \*enter an "X" next to the samples that are being batched together <page down>
  - \*enter "SDUP" for QCTYPE and sample ID <end>
2. Enter data from sample analysis into pH Data Entry menu by:
  - \*Go back to Lab Main Menu <F3>
  - \*Go to Results Data Entry <end>
  - \*Go to Wetchem Data Entry <end>
  - \*Go to pH Data Entry <end>
  - \*Type in: batch# <tab>;ICV, results, sample number, QC#, CCV <end>
3. Print Sample Batch and pH Preliminary Results Reports by:
  - \*GO back to Lab Main Menu <F3>
  - \*Go to Lab Report Menu <>
  - \*Select Sample batch report<>
  - \*Enter batch#
  - \*Go back to Lab Report Menu <F3>
  - \* GO to Preliminary Reports Menu <>
  - \*Wetchem Reports<>
  - \*pH Batch Report <>
  - \*Enter Batch# <>

### APPENDIX 1

#### *RELATIVE PERCENT DIFFERENCE (RPD):*

The RPD is the quotient of the first sample result less the second (duplicate) sample result divided by the mean of the results multiplied by 100.

$$RPD = \frac{R1 - R2}{(R1 + R2)/2} \times 100$$

**EPA METHOD 26A**

## Method 26A - Determination of Hydrogen Halide and Halogen Emissions from Stationary Sources - Isokinetic Method

### 1. APPLICABILITY, PRINCIPLE, INTERFERENCES, PRECISION, BIAS, AND STABILITY

1.1 **Applicability.** This method is applicable for determining emissions of hydrogen halides (HX) [hydrogen chloride (HCl), hydrogen bromide (HBr), and hydrogen fluoride (HF)] and halogens (X<sub>2</sub>) [chlorine (Cl<sub>2</sub>) and bromine (Br<sub>2</sub>)] from stationary sources. This method collects the emission sample isokinetically and is therefore particularly suited for sampling at sources, such as those controlled by wet scrubbers, emitting acid particulate matter (e.g., hydrogen halides dissolved in water droplets). [Note: Mention of trade names or specific products does not constitute endorsement by the Environmental Protection Agency.]

1.2 **Principle.** Gaseous and particulate pollutants are withdrawn isokinetically from the source and collected in an optional cyclone, on a filter, and in absorbing solutions. The cyclone collects any liquid droplets and is not necessary if the source emissions do not contain them; however, it is preferable to include the cyclone in the sampling train to protect the filter from any moisture present. The filter collects other particulate matter including halide salts. Acidic and alkaline absorbing solutions collect the gaseous hydrogen halides and halogens, respectively. Following sampling of emissions containing liquid droplets, any halides/halogens dissolved in the liquid in the cyclone and on the filter are vaporized to gas and

collected in the impingers by pulling conditioned ambient air through the sampling train. The hydrogen halides are solubilized in the acidic solution and form chloride ( $\text{Cl}^-$ ), bromide ( $\text{Br}^-$ ), and fluoride ( $\text{F}^-$ ) ions. The halogens have a very low solubility in the acidic solution and pass through to the alkaline solution where they are hydrolyzed to form a proton ( $\text{H}^+$ ), the halide ion, and the hypohalous acid ( $\text{HClO}$  or  $\text{HBrO}$ ). Sodium thiosulfate is added to the alkaline solution to assure reaction with the hypohalous acid to form a second halide ion such that 2 halide ions are formed for each molecule of halogen gas. The halide ions in the separate solutions are measured by ion chromatography (IC). If desired, the particulate matter recovered from the filter and the probe is analyzed following the procedures in Method 5. [Note: If the tester intends to use this sampling arrangement to sample concurrently for particulate matter, the alternative Teflon<sup>R</sup> probe liner, cyclone, and filter holder should not be used. The Teflon<sup>R</sup> filter support must be used. The tester must also meet the probe and filter temperature requirements of both sampling trains.]

1.3 Interferences. Volatile materials, such as chlorine dioxide ( $\text{ClO}_2$ ) and ammonium chloride ( $\text{NH}_4\text{Cl}$ ), which produce halide ions upon dissolution during sampling are potential interferences. Interferences for the halide measurements are the halogen gases which disproportionate to a hydrogen halide and an hypohalous acid upon dissolution in water. The use of acidic rather than neutral or basic solutions for collection of the hydrogen halides greatly reduces the dissolution of any halogens

passing through this solution. The simultaneous presence of both HBr and Cl<sub>2</sub> may cause a positive bias in the HCl result with a corresponding negative bias in the Cl<sub>2</sub> result as well as affecting the HBr/Br<sub>2</sub> split. High concentrations of nitrogen oxides (NO<sub>x</sub>) may produce sufficient nitrate (NO<sub>3</sub><sup>-</sup>) to interfere with measurements of very low Br<sup>-</sup> levels.

**1.4 Precision and Bias.** The method has a possible measurable negative bias below 20 ppm HCl perhaps due to reaction with small amounts of moisture in the probe and filter. Similar bias for the other hydrogen halides is possible.

**1.5 Sample Stability.** The collected Cl<sup>-</sup> samples can be stored for up to 4 weeks for analysis for HCl and Cl<sub>2</sub>.

**1.6 Detection Limit.** The in-stack detection limit for HCl is approximately 0.02 μg per liter of stack gas; the analytical detection limit for HCl is 0.1 μg/ml. Detection limits for the other analyses should be similar.

## 2. APPARATUS

**2.1 Sampling.** The sampling train is shown in Figure 26A-1; the apparatus is similar to the Method 5 train where noted as follows:

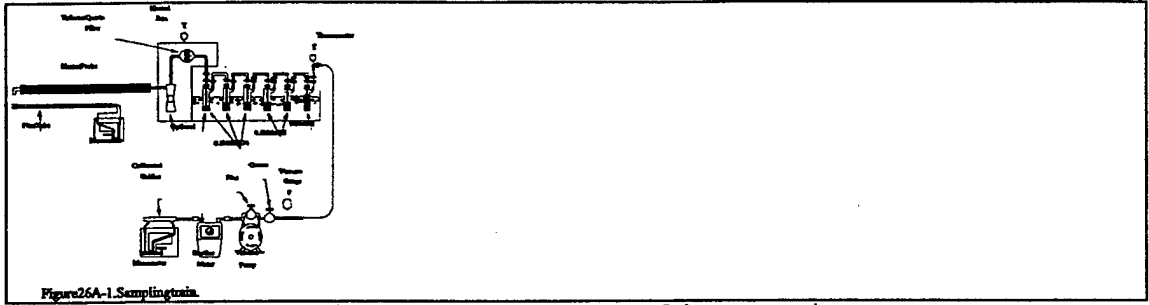

Figure 26A-1. Sampling Train

Figure 26A-1. Sampling Train

circumference. The holder shall be attached immediately to the outlet of the cyclone.

**2.1.6 Impinger Train.** The following system shall be used to determine the stack gas moisture content and to collect the hydrogen halides and halogens: five or six impingers connected in series with leak-free ground glass fittings or any similar leak-free noncontaminating fittings. The first impinger shown in Figure 26A-1 (knockout or condensate impinger) is optional and is recommended as a water knockout trap for use under high moisture conditions. If used, this impinger should be constructed as described below for the alkaline impingers, but with a shortened stem, and should contain 50 ml of 0.1 N  $H_2SO_4$ . The following two impingers (acid impingers which each contain 100 ml of 0.1 N  $H_2SO_4$ ) shall be of the Greenburg-Smith design with the standard tip (Method 5, Section 2.1.7). The next two impingers (alkaline impingers which each contain 100 ml of 0.1 N NaOH) and the last impinger (containing silica gel) shall be of the modified Greenburg-Smith design (Method 5, Section 2.1.7). The condensate, acid, and alkaline impingers shall contain known quantities of the appropriate absorbing reagents. The last impinger shall contain a known weight of silica gel or equivalent desiccant. Teflon<sup>R</sup> impingers are an acceptable alternative.

**2.1.7 Ambient Air Conditioning Tube (Optional).** Tube tightly packed with approximately 150 g of fresh 8 to 20 mesh sodium hydroxide-coated silica, or equivalent, (Ascarite II<sup>R</sup> has been found suitable) to dry and remove acid gases from the ambient air used to remove moisture from the filter and cyclone,

when the cyclone is used. The inlet and outlet ends of the tube should be packed with at least 1-cm thickness of glass wool or filter material suitable to prevent escape of fines. Fit one end with flexible tubing, etc. to allow connection to probe nozzle following the test run.

2.2 Sample Recovery. The following items are needed:

2.2.1 Probe-Liner and Probe-Nozzle Brushes, Wash Bottles, Glass Sample Storage Containers, Petri Dishes, Graduated Cylinder or Balance, and Rubber Policeman. Same as Method 5, Sections 2.2.1, 2.2.2, 2.2.3, 2.2.4, 2.2.5, and 2.2.7.

2.2.2 Plastic Storage Containers. Screw-cap polypropylene or polyethylene containers to store silica gel. High-density polyethylene bottles with Teflon screw cap liners to store impinger reagents, 1-liter.

2.2.3 Funnels. Glass or high-density polyethylene, to aid in sample recovery.

2.3 Analysis. For analysis, the following equipment is needed:

2.3.1 Volumetric Flasks. Class A, various sizes.

2.3.2 Volumetric Pipettes. Class A, assortment, to dilute samples to calibration range of the ion chromatograph (IC).

2.3.3 Ion Chromatograph. Suppressed or nonsuppressed, with a conductivity detector and electronic integrator operating in the peak area mode. Other detectors, a strip chart recorder, and peak heights may be used.

### 3. REAGENTS

Unless otherwise indicated, all reagents must conform to the

specifications of the Committee on Analytical Reagents of the American Chemical Society (ACS reagent grade). When such specifications are not available, the best available grade shall be used.

### 3.1 Sampling.

3.1.1 Water. Deionized, distilled water that conforms to American Society of Testing and Materials (ASTM) Specification D 1193-77, Type 3.

3.1.2 Acidic Absorbing Solution, 0.1 N Sulfuric Acid ( $\text{H}_2\text{SO}_4$ ). To prepare 1 L, slowly add 2.80 ml of concentrated  $\text{H}_2\text{SO}_4$  to about 900 ml of water while stirring, and adjust the final volume to 1 L using additional water. Shake well to mix the solution.

3.1.3 Alkaline Absorbing Solution, 0.1 N Sodium Hydroxide ( $\text{NaOH}$ ). To prepare 1 L, dissolve 4.00 g of solid  $\text{NaOH}$  in about 900 ml of water and adjust the final volume to 1 L using additional water. Shake well to mix the solution.

3.1.4 Filter. Teflon<sup>R</sup> mat (e.g., Pallflex<sup>R</sup> TX40HI45) filter. When the stack gas temperature exceeds 210 °C (410 °F) a quartz fiber filter may be used.

3.1.5 Silica Gel, Crushed Ice, and Stopcock Grease. Same as Method 5, Sections 3.1.2, 3.1.4, and 3.1.5, respectively.

3.1.6 Sodium Thiosulfate, ( $\text{Na}_2\text{S}_2\text{O}_3 \cdot 5 \text{H}_2\text{O}$ ).

### 3.2 Sample Recovery.

3.2.1 Water. Same as Section 3.1.1.

3.2.2 Acetone. Same as Method 5, Section 3.2.

### 3.3 Sample Analysis.

3.3.1 Water. Same as Section 3.1.1.

3.3.2 Reagent Blanks. A separate blank solution of each absorbing reagent should be prepared for analysis with the field samples. Dilute 200 ml of each absorbing solution (250 ml of the acidic absorbing solution, if a condensate impinger is used) to the same final volume as the field samples using the blank sample of rinse water. If a particulate determination is conducted, collect a blank sample of acetone.

3.3.3 Halide Salt Stock Standard Solutions. Prepare concentrated stock solutions from reagent grade sodium chloride (NaCl), sodium bromide (NaBr), and sodium fluoride (NaF). Each must be dried at 110°C for 2 or more hours and then cooled to room temperature in a desiccator immediately before weighing. Accurately weigh 1.6 to 1.7 g of the dried NaCl to within 0.1 mg, dissolve in water, and dilute to 1 liter. Calculate the exact Cl<sup>-</sup> concentration using Equation 26A-1.

$$\mu\text{g Cl}^-/\text{ml} = \text{g of NaCl} \times 10^3 \times 35.453/58.44 \quad \text{Eq. 26A-1}$$

In a similar manner, accurately weigh and solubilize 1.2 to 1.3 g of dried NaBr and 2.2 to 2.3 g of NaF to make 1-liter solutions. Use Equations 26A-2 and 26A-3 to calculate the Br<sup>-</sup> and F<sup>-</sup> concentrations.

$$\mu\text{g Br}^-/\text{ml} = \text{g of NaBr} \times 10^3 \times 79.904/102.90 \quad \text{Eq. 26A-2}$$

$$\mu\text{g F}^-/\text{ml} = \text{g of NaF} \times 10^3 \times 18.998/41.99 \quad \text{Eq. 26A-3}$$

Alternately, solutions containing a nominal certified concentration of 1000 mg/L NaCl are commercially available as convenient stock solutions from which standards can be made by

appropriate volumetric dilution. Refrigerate the stock standard solutions and store no longer than 1 month.

**3.3.4 Chromatographic Eluent.** Same as Method 26, Section 3.2.4.

#### **4. PROCEDURE**

Because of the complexity of this method, testers and analysts should be trained and experienced with the procedures to ensure reliable results.

##### **4.1 Sampling.**

**4.1.1 Pretest Preparation.** Follow the general procedure given in Method 5, Section 4.1.1, except the filter need only be desiccated and weighed if a particulate determination will be conducted.

**4.1.2 Preliminary Determinations.** Same as Method 5, Section 4.1.2.

**4.1.3 Preparation of Sampling Train.** Follow the general procedure given in Method 5, Section 4.1.3, except for the following variations:

Add 50 ml of 0.1 N  $H_2SO_4$  to the condensate impinger, if used. Place 100 ml of 0.1 N  $H_2SO_4$  in each of the next two impingers. Place 100 ml of 0.1 N NaOH in each of the following two impingers. Finally, transfer approximately 200-300 g of preweighed silica gel from its container to the last impinger. Set up the train as in Figure 26A-1. When used, the optional cyclone is inserted between the probe liner and filter holder and located in the heated filter box.

**4.1.4 Leak-Check Procedures.** Follow the leak-check

procedures given in Method 5, Sections 4.4.1 (Pretest Leak-Check), 4.1.4.2 (Leak-Checks During the Sample Run), and 4.1.4.3 (Post-Test Leak-Check).

**4.1.5 Train Operation.** Follow the general procedure given in Method 5, Section 4.1.5. Maintain a temperature around the filter and (cyclone, if used) of greater than 120 °C (248 °F). For each run, record the data required on a data sheet such as the one shown in Method 5, Figure 5-2. If the condensate impinger becomes too full, it may be emptied, recharged with 50 ml of 0.1 N H<sub>2</sub>SO<sub>4</sub>, and replaced during the sample run. The condensate emptied must be saved and included in the measurement of the volume of moisture collected and included in the sample for analysis. The additional 50 ml of absorbing reagent must also be considered in calculating the moisture. After the impinger is reinstalled in the train, conduct a leak-check as described in Method 5, Section 4.1.4.2.

**4.1.6 Post-Test Moisture Removal (Optional).** When the optional cyclone is included in the sampling train or when moisture is visible on the filter at the end of a sample run even in the absence of a cyclone, perform the following procedure. Upon completion of the test run, connect the ambient air conditioning tube at the probe inlet and operate the train with the filter heating system at least 120 °C (248 °F) at a low flow rate (e.g.,  $\Delta H = 1$  in. H<sub>2</sub>O) to vaporize any liquid and hydrogen halides in the cyclone or on the filter and pull them through the train into the impingers. After 30 minutes, turn off the flow, remove the conditioning tube, and examine the cyclone and filter

for any visible moisture. If moisture is visible, repeat this step for 15 minutes and observe again. Keep repeating until the cyclone is dry. [Note: It is critical that this is repeated until the cyclone is completely dry.]

**4.2 Sample Recovery.** Allow the probe to cool. When the probe can be handled safely, wipe off all the external surfaces of the tip of the probe nozzle and place a cap loosely over the tip. Do not cap the probe tip tightly while the sampling train is cooling down because this will create a vacuum in the filter holder, drawing water from the impingers into the holder. Before moving the sampling train to the cleanup site, remove the probe, wipe off any silicone grease, and cap the open outlet of the impinger train, being careful not to lose any condensate that might be present. Wipe off any silicone grease and cap the filter or cyclone inlet. Remove the umbilical cord from the last impinger and cap the impinger. If a flexible line is used between the first impinger and the filter holder, disconnect it at the filter holder and let any condensed water drain into the first impinger. Wipe off any silicone grease and cap the filter holder outlet and the impinger inlet. Ground glass stoppers, plastic caps, serum caps, Teflon<sup>R</sup> tape, Parafilm<sup>R</sup>, or aluminum foil may be used to close these openings. Transfer the probe and filter/impinger assembly to the cleanup area. This area should be clean and protected from the weather to minimize sample contamination or loss. Inspect the train prior to and during disassembly and note any abnormal conditions. Treat samples as follows:

4.2.1 Container No. 1 (Optional; Filter Catch for Particulate Determination). Same as Method 5, Section 4.2, Container No. 1.

4.2.2 Container No. 2 (Optional; Front-Half Rinse for Particulate Determination). Same as Method 5, Section 4.2, Container No. 2.

4.2.3 Container No. 3 (Knockout and Acid Impinger Catch for Moisture and Hydrogen Halide Determination). Disconnect the impingers. Measure the liquid in the acid and knockout impingers to  $\pm 1$  ml by using a graduated cylinder or by weighing it to  $\pm 0.5$  g by using a balance. Record the volume or weight of liquid present. This information is required to calculate the moisture content of the effluent gas. Quantitatively transfer this liquid to a leak-free sample storage container. Rinse these impingers and connecting glassware including the back portion of the filter holder (and flexible tubing, if used) with water and add these rinses to the storage container. Seal the container, shake to mix, and label. The fluid level should be marked so that if any sample is lost during transport, a correction proportional to the lost volume can be applied. Retain rinse water and acidic absorbing solution blanks and analyze with the samples.

4.2.4 Container No. 4 (Alkaline Impinger Catch for Halogen and Moisture Determination). Measure and record the liquid in the alkaline impingers as described in Section 4.2.3. Quantitatively transfer this liquid to a leak-free sample storage container. Rinse these two impingers and connecting glassware with water and add these rinses to the container. Add 25 mg of

sodium thiosulfate per ppm halogen-dscom of stack gas sampled. [Note: This amount of sodium thiosulfate includes a safety factor of approximately 5 to assure complete reaction with the hypohalous acid to form a second  $\text{Cl}^-$  ion in the alkaline solution.] Seal the container, shake to mix, and label; mark the fluid level. Retain alkaline absorbing solution blank and analyze with the samples.

**4.2.5 Container No. 5 (Silica Gel for Moisture Determination).** Same as Method 5, Section 4.2, *Container No. 3*.

**4.2.6 Container Nos. 6 through 9 (Reagent Blanks).** Save portions of the absorbing reagents (0.1 N  $\text{H}_2\text{SO}_4$  and 0.1 N NaOH) equivalent to the amount used in the sampling train; dilute to the approximate volume of the corresponding samples using rinse water directly from the wash bottle being used. Add the same ratio of sodium thiosulfate solution used in container No. 4 to the 0.1 N NaOH absorbing reagent blank. Also, save a portion of the rinse water alone and a portion of the acetone equivalent to the amount used to rinse the front half of the sampling train. Place each in a separate, pre-labeled sample container.

**4.2.7** Prior to shipment, recheck all sample containers to ensure that the caps are well-secured. Seal the lids of all containers around the circumference with Teflon<sup>R</sup> tape. Ship all liquid samples upright and all particulate filters with the particulate catch facing upward.

**4.3 Sample Preparation and Analysis.** Note the liquid levels in the sample containers and confirm on the analysis sheet whether or not leakage occurred during transport. If a

noticeable leakage has occurred, either void the sample or use methods, subject to the approval of the Administrator, to correct the final results.

4.3.1 Container Nos. 1 and 2 and Acetone Blank (Optional; Particulate Determination). Same as Method 5, Section 4.3.

4.3.2 Container No. 5. Same as Method 5, Section 4.3 for silica gel.

4.3.3 Container Nos. 3 and 4 and Absorbing Solution and Water Blanks. Quantitatively transfer each sample to a volumetric flask or graduated cylinder and dilute with water to a final volume within 50 ml of the largest sample.

4.3.3.1 The IC conditions will depend upon analytical column type and whether suppressed or nonsuppressed IC is used. Prior to calibration and sample analysis, establish a stable baseline. Next, inject a sample of water, and determine if any  $\text{Cl}^-$ ,  $\text{Br}^-$ , or  $\text{F}^-$  appears in the chromatogram. If any of these ions are present, repeat the load/injection procedure until they are no longer present. Analysis of the acid and alkaline absorbing solution samples requires separate standard calibration curves; prepare each according to Section 5.2. Ensure adequate baseline separation of the analyses.

4.3.3.2 Between injections of the appropriate series of calibration standards, inject in duplicate the reagent blanks and the field samples. Measure the areas or heights of the  $\text{Cl}^-$ ,  $\text{Br}^-$ , and  $\text{F}^-$  peaks. Use the average response to determine the concentrations of the field samples and reagent blanks using the linear calibration curve. If the values from duplicate

injections are not within 5 percent of their mean, the duplicate injection shall be repeated and all four values used to determine the average response. Dilute any sample and the blank with equal volumes of water if the concentration exceeds that of the highest standard.

**4.4 Audit Sample Analysis.** Audit samples must be analyzed subject to availability.

## **5. CALIBRATION**

Maintain a laboratory log of all calibrations.

**5.1 Probe Nozzle, Pitot Tube, Dry Gas Metering System, Probe Heater, Temperature Gauges, Leak-Check of Metering System, and Barometer.** Same as Method 5, Sections 5.1, 5.2, 5.3, 5.4, 5.5, 5.6, and 5.7, respectively.

**5.2 Ion Chromatograph.** To prepare the calibration standards, dilute given amounts (1.0 ml or greater) of the stock standard solutions to convenient volumes, using 0.1 N H<sub>2</sub>SO<sub>4</sub> or 0.1 N NaOH, as appropriate. Prepare at least four calibration standards for each absorbing reagent containing the three stock solutions such that they are within the linear range of the field samples. Using one of the standards in each series, ensure adequate baseline separation for the peaks of interest. Inject the appropriate series of calibration standards, starting with the lowest concentration standard first both before and after injection of the quality control check sample, reagent blanks, and field samples. This allows compensation for any instrument drift occurring during sample analysis. Determine the peak areas, or height, of the standards and plot individual values

versus halide ion concentrations in  $\mu\text{g/ml}$ . Draw a smooth curve through the points. Use linear regression to calculate a formula describing the resulting linear curve.

#### 6. QUALITY CONTROL

Same as Method 5, Section 4.4.

#### 7. QUALITY ASSURANCE

7.1 Applicability. When the method is used to demonstrate compliance with a regulation, a set of two audit samples shall be analyzed.

7.2 Audit Procedure. The currently available audit samples are chloride solutions. Concurrently analyze the two audit samples and a set of compliance samples in the same manner to evaluate the technique of the analyst and the standards preparation. The same analyst, analytical reagents, and analytical system shall be used both for compliance samples and the Environmental Protection Agency (EPA) audit samples.

7.3 Audit Sample Availability. Audit samples will be supplied only to enforcement agencies for compliance tests. Audit samples may be obtained by writing the Source Test Audit Coordinator (MD-77B), Quality Assurance Division, Atmospheric Research and Exposure Assessment Laboratory, U.S. Environmental Protection Laboratory, Research Triangle Park, NC 27711 or by calling the Source Test Audit Coordinator (STAC) at (919) 541-7834. The request for the audit samples should be made at least 30 days prior to the scheduled compliance sample analysis.

7.4 Audit Results. Calculate the concentrations in  $\text{mg/dscm}$

using the specified sample volume in the audit instructions. Include the results of both audit samples, their identification numbers, and the analyst's name with the results of the compliance determination samples in appropriate reports to the EPA regional office or the appropriate enforcement agency.

(NOTE: Acceptability of results may be obtained immediately by reporting the audit results in mg/dscm and compliance results in total  $\mu\text{g HCl/sample}$  to the responsible enforcement agency.) The concentrations of the audit samples obtained by the analyst shall agree within 10 percent of the actual concentrations. If the 10 percent specification is not met, reanalyze the compliance samples and audit samples, and include initial and reanalysis values in the test report. Failure to meet the 10 percent specification may require retests until the audit problems are resolved.

## 8. CALCULATIONS

Retain at least one extra decimal figure beyond those contained in the available data in intermediate calculations, and round off only the final answer appropriately.

8.1 Nomenclature. Same as Method 5, Section 6.1. In addition:

1  $B_{x-}$  = Mass concentration of applicable absorbing solution blank,  $\mu\text{g halide ion (Cl}^-, \text{Br}^-, \text{F}^-)/\text{ml}$ , not to exceed  $1 \mu\text{g/ml}$  which is 10 times the published analytical detection limit of  $0.1 \mu\text{g/ml}$ . (It is also approximately 5 percent of the mass

concentration anticipated to result from a one hour sample at 10 ppmv HCl.)

- C = Concentration of hydrogen halide (HX) or halogen (X<sub>2</sub>), dry basis, mg/dscm.
- m<sub>HX</sub> = Mass of HCl, HBr, or HF in sample, ug.
- m<sub>X<sub>2</sub></sub> = Mass of Cl<sub>2</sub> or Br<sub>2</sub> in sample, ug.
- S<sub>X<sup>-</sup></sub> = Analysis of sample, ug halide ion (Cl<sup>-</sup>, Br<sup>-</sup>, F<sup>-</sup>)/ml.
- V<sub>s</sub> = Volume of filtered and diluted sample, ml.

8.2 Average Dry Gas Meter Temperature and Average Orifice Pressure Drop. See data sheet (Figure 5-2 of Method 5).

8.3 Dry Gas Volume. Calculate V<sub>m(std)</sub> and adjust for leakage, if necessary, using the equation in Section 6.3 of Method 5.

8.4 Volume of Water Vapor and Moisture Content. Calculate the volume of water vapor V<sub>w(std)</sub> and moisture content B<sub>ws</sub> from the data obtained in this method (Figure 5-2 of Method 5); use Equations 5-2 and 5-3 of Method 5.

8.5 Isokinetic Variation and Acceptable Results. Use Method 5, Sections 6.11 and 6.12.

8.6 Acetone Blank Concentration, Acetone Wash Blank Residue Weight, Particulate Weight, and Particulate Concentration. For particulate determination.

8.7 Total ug HCl, HBr, or HF Per Sample.

$$m_{HX} = K V_s (S_{X^-} - B_{X^-}) \quad \text{Eq. 26A-4}$$

where:  $K_{HCl} = 1.028 (\mu\text{g HCl}/\mu\text{g-mole})/(\mu\text{g Cl}^-/\mu\text{g-mole})$ .

$$K_{\text{HBr}} = 1.013 (\mu\text{g HBr}/\mu\text{g-mole})/(\mu\text{g Br}^-/\mu\text{g-mole}).$$

$$K_{\text{HF}} = 1.053 (\mu\text{g HF}/\mu\text{g-mole})/(\mu\text{g F}^-/\mu\text{g-mole}).$$

### 8.8 Total $\mu\text{g Cl}_2$ or $\text{Br}_2$ Per Sample.

$$m_{\text{X}_2} = V_s (S_{\text{X}^-} - B_{\text{X}^-}) \quad \text{Eq. 26A-5}$$

### 8.9 Concentration of Hydrogen Halide or Halogen in Flue Gas.

$$C = K m_{\text{HX}, \text{X}_2}/V_{\text{m(std)}} \quad \text{Eq. 26A-6}$$

where:  $K = 10^{-3} \text{ mg}/\mu\text{g}$

### 8.10 Stack Gas Velocity and Volumetric Flow Rate.

Calculate the average stack gas velocity and volumetric flow rate, if needed, using data obtained in this method and the equations in Sections 5.2 and 5.3 of Method 2.

## 9. BIBLIOGRAPHY

1. Steinsberger, S. C. and J. H. Margeson. Laboratory and Field Evaluation of a Methodology for Determination of Hydrogen Chloride Emissions from Municipal and Hazardous Waste Incinerators. U.S. Environmental Protection Agency, Office of Research and Development. Publication No. 600/3-89/064. April 1989. Available from National Technical Information Service, Springfield, VA 22161 as PB89220586/AS.
2. State of California Air Resources Board. Method 421 - Determination of Hydrochloric Acid Emissions from Stationary Sources. March 18, 1987.
3. Cheney, J.L. and C.R. Fortune. Improvements in the Methodology for Measuring Hydrochloric Acid in Combustion Source Emissions. J. Environ. Sci. Health. A19(3): 337-350. 1984.

4. Stern, D.A., B.M. Myatt, J.F. Lachowski, and K.T. McGregor. Speciation of Halogen and Hydrogen Halide Compounds in Gaseous Emissions. In: Incineration and Treatment of Hazardous Waste: Proceedings of the 9th Annual Research Symposium, Cincinnati, Ohio, May 2-4, 1983. Publication No. 600/9-84-015. July 1984. Available from National Technical Information Service, Springfield, VA 22161 as PB84-234525.

5. Holm, R.D. and S.A. Barksdale. Analysis of Anions in Combustion Products. In: Ion Chromatographic Analysis of Environmental Pollutants, E. Sawicki, J.D. Mulik, and E. Wittgenstein (eds.). Ann Arbor, Michigan, Ann Arbor Science Publishers. 1978. pp. 99-110.

**EPA METHOD TO6**

METHOD FOR THE DETERMINATION OF PHOSGENE  
IN AMBIENT AIR USING HIGH PERFORMANCE LIQUID CHROMATOGRAPHY

## 1. Scope

- 1.1 This document describes a method for determination of phosgene in ambient air, in which phosgene is collected by passage of the air through a solution of aniline, forming carbanilide. The carbanilide is determined by HPLC. The method can be used to detect phosgene at the 0.1 ppbv level.
- 1.2 Precision for phosgene spiked into a clean air stream is  $\pm 15-20\%$  relative standard deviation. Recovery is quantitative within that precision, down to less than 3 ppbv. This method has been developed and tested by a single laboratory(1), and, consequently, each laboratory desiring to use the method should acquire sufficient precision and recovery data to verify performance under those particular conditions. This method is more sensitive, and probably more selective, than the standard colorimetric procedure currently in widespread use for workplace monitoring(2).

## 2. Applicable Documents

## 2.1 ASTM Standards

D1356 - Definitions of Terms Related to Atmospheric Sampling and Analysis(3).

## 2.2 Other Documents

Standard NIOSH Procedure for Phosgene(2).  
U.S. EPA Technical Assistance Document(4).

### 3. Summary of Method

- 3.1 Ambient air is drawn through a midjet impinger containing 10 mL of 2/98 aniline/toluene (by volume). Phosgene readily reacts with aniline to form carbanilide (1,3-diphenylurea), which is stable indefinitely.
- 3.2 After sampling, the impinger contents are transferred to a screw-capped vial having a Teflon-lined cap and returned to the laboratory for analysis.
- 3.3 The solution is taken to dryness by heating to 60°C on an aluminum heating block under a gentle stream of pure nitrogen gas. The residue is dissolved in 1 mL of acetonitrile.
- 3.4 Carbanilide is determined in the acetonitrile solution using reverse-phase HPLC with an ultraviolet absorbance (UV) detector operating at 254 nm.

### 4. Significance

- 4.1 Phosgene is widely used in industrial operations, primarily in the synthetic organic chemicals industry. In addition, phosgene is produced by photochemical degradation of chlorinated hydrocarbons (e.g., trichloroethylene) emitted from various sources. Although phosgene is acutely toxic, its effects at low levels (i.e., 1 ppbv and below) are unknown. Nonetheless, its emission into and/or formation in ambient air is of potential concern.
- 4.2 The conventional method for phosgene has utilized a colorimetric procedure involving reaction with 4,4'-nitrobenzyl pyridine in diethyl phthalate. This method cannot detect phosgene levels below 10 ppbv and is subject to numerous interferences. The method described herein is more sensitive (0.1 ppbv detection limit) and is believed to be more selective due to the chromatographic separation step. However, the method needs to be more rigorously tested for interferences before its degree of selectivity can be firmly established.

## 5. Definitions

Definitions used in this document and in any user-prepared SOPs should be consistent with ASTM D1356 (3). All abbreviations and symbols are defined within this document at the point of use.

## 6. Interferences

- 6.1 There are very few interferences in the method, although this aspect of the method needs to be more thoroughly investigated. Ambient levels of nitrogen oxides, ozone, water vapor, and SO<sub>2</sub> are known not to interfere. Chloroformates can cause interferences by reacting with the aniline to form urea, which produces a peak that overlies the carbanilide peak in the HPLC trace. Presence of chloroformates should be documented before use of this method. However, the inclusion of a HPLC step overcomes most potential interferences from other organic compounds. High concentrations of acidic materials can cause precipitation of aniline salts in the impinger, thus reducing the amount of available reagent.
- 6.2 Purity of the aniline reagent is a critical factor, since traces of carbanilide have been found in reagent-grade aniline. This problem can be overcome by vacuum distillation of aniline in an all-glass apparatus.

## 7. Apparatus

- 7.1 Isocratic high performance liquid chromatography (HPLC) system consisting of a mobile-phase reservoir, a high-pressure pump, an injection valve, a Zorbax ODS or C-18 reverse-phase column, or equivalent (25 cm x 4.6 mm ID), a variable-wavelength UV detector operating at 254 nm, and a data system or strip-chart recorder (Figure 1).
- 7.2 Sampling system - capable of accurately and precisely sampling 100-1000 mL/minute of ambient air (Figure 2).

- 7.3 Stopwatch.
- 7.4 Friction-top metal can, e.g., one-gallon (paint can) - to hold sampling reagent and samples.
- 7.5 Thermometer - to record ambient temperature.
- 7.6 Barometer (optional).
- 7.7 Analytical balance - 0.1 mg sensitivity.
- 7.8 Midget impingers - jet inlet type, 25 mL.
- 7.9 Nitrogen evaporator with heating block - for concentrating samples.
- 7.10 Suction filtration apparatus - for filtering HPLC mobile phase.
- 7.11 Volumetric flasks - 100 mL and 500 mL.
- 7.12 Pipettes - various sizes, 1-10 mL.
- 7.13 Helium purge line (optional) - for degassing HPLC mobile phase.
- 7.14 Erlenmeyer flask, 1-L - for preparing HPLC mobile phase.
- 7.15 Graduated cylinder, 1 L - for preparing HPLC mobile phase.
- 7.16 Microliter syringe, 10-25  $\mu$ L - for HPLC injection.

## 8. Reagents and Materials

- 8.1 Bottles, 16 oz. glass, with Teflon-lined screw cap - for storing sampling reagent.
- 8.2 Vials, 20 mL, with Teflon-lined screw cap - for holding samples and extracts.
- 8.3 Granular charcoal.
- 8.4 Acetonitrile, toluene, and methanol - distilled in glass or pesticide grade.
- 8.5 Aniline - 99+%, gold label from Aldrich Chemical Co., or equivalent.

- 8.6 Carbanilide - highest purity available; Aldrich Chemical Co., or equivalent.
- 8.7 Nitrogen, compressed gas cylinder - 99.99% purity for sample evaporation.
- 8.8 Polyester filters, 0.22  $\mu$ m - Nuclepore, or equiv.

## 9. Preparation of Sampling Reagent

- 9.1 Sampling reagent is prepared by placing 5.0 mL of aniline in a 250-mL volumetric flask and diluting to the mark with toluene. The flask is inverted 10-20 times to mix the reagent. The reagent is then placed in a clear 16-ounce bottle with a Teflon-lined screw cap. The reagent is refrigerated until use.
- 9.2 Before use, each batch of reagent is checked for purity by analyzing a 10-mL portion according to the procedure described in Section 11. If acceptable purity (<50 ng of carbanilide per 10 mL of reagent) is not obtained, the aniline or toluene is probably contaminated.

## 10. Sampling

- 10.1 The sampling apparatus is assembled and should be similar to that shown in Figure 2. EPA Method 6 uses essentially the same sampling system (5). All glassware (e.g., impingers, sampling bottles, etc.) must be thoroughly rinsed with methanol and oven-dried before use.
- 10.2 Before sample collection, the entire assembly (including empty sample impingers) is installed and the flow rate checked at a value near the desired rate. Flow rates greater than 1000 mL/minute (+2%) should not be used because impinger collection efficiency may decrease. Generally, calibration is accomplished using a soap bubble flow

meter or calibrated wet test meter connected to the flow exit, assuming that the entire system is sealed. ASTM Method D3686 describes an appropriate calibration scheme that does not require a sealed-flow system downstream of the pump (3).

- 10.3 Ideally, a dry gas meter is included in the system to record total flow, if the flow rate is sufficient for its use. If a dry gas meter is not available, the operator must measure and record the sampling flow rate at the beginning and end of the sampling period to determine sample volume. If the sampling time exceeds two hours, the flow rate should be measured at intermediate points during the sampling period. Ideally, a rotameter should be included to allow observation of the flow rate without interruption of the sampling process.
- 10.4 To collect an air sample, the midget impingers are loaded with 10 mL each of sampling reagent. The impingers are installed in the sampling system and sample flow is started. The following parameters are recorded on the data sheet (see Figure 3 for an example): date, sampling location, time, ambient temperature, barometric pressure (if available), relative humidity (if available), dry gas meter reading (if appropriate), flow rate, rotameter setting, sampling reagent batch number, and dry gas meter and pump identification numbers.
- 10.5 The sampler is allowed to operate for the desired period, with periodic recording of the variables listed above. The total flow should not exceed 50 L. If it does, the operator must use a second impinger.
- 10.6 At the end of the sampling period the parameters listed in Section 10.4 are recorded and the sample flow is stopped. If a dry gas meter is not used, the flow rate must be checked at the end of the sampling interval. If the flow rates at the beginning and end of the sampling period differ by more than 15%, the sample should be marked as suspect.

- 10.7 Immediately after sampling, the impinger is removed from the sampling system. The contents of the impinger are emptied into a clean 20-mL glass vial with a Teflon-lined screw cap. The impinger is then rinsed with 2-3 mL of toluene and the rinse solution is added to the vial. The vial is then capped, sealed with Teflon tape, and placed in a friction-top can containing 1-2 inches of granular charcoal. The samples are stored in the can and refrigerated until analysis.
- 10.8 If a dry gas meter or equivalent total flow indicator is not used, the average sample flow rate must be calculated according to the following equation:

$$Q_A = \frac{Q_1 + Q_2 + \dots + Q_N}{N}$$

where

- $Q_A$  = average flow rate (mL/minute).  
 $Q_1, Q_2, \dots, Q_N$  = flow rates determined at the beginning, end, and intermediate points during sampling.  
 $N$  = number of points averaged.

- 10.9 The total flow is then calculated using the following equation:

$$V_m = \frac{(T_2 - T_1)Q_A}{1000}$$

where

- $V_m$  = total sample volume (L) at measured temperature and pressure.  
 $T_2$  = stop time.  
 $T_1$  = start time.  
 $T_2 - T_1$  = total sampling time (minutes).  
 $Q_a$  = average flow rate (mL/minute).

## 11. Sample Analysis

### 11.1 Sample Preparation

- 11.1.1 The samples are returned to the laboratory in 20-ml screw-capped vials and refrigerated in charcoal containing cans until analysis.
- 11.1.2 The sample vial is placed in an aluminum heating block maintained at 60°C and a gentle stream of pure nitrogen gas is directed across the sample.
- 11.1.3 When the sample reaches complete dryness, the vial is removed from the heating block, capped, and cooled to near room temperature. A 1-mL volume of HPLC mobile phase (50/50 acetonitrile/water) is placed in the vial. The vial is then capped and gently shaken to dissolve the residue.
- 11.1.4 The concentrated sample is then refrigerated until HPLC analysis, as described in Section 11.2.

### 11.2 HPLC Analysis

- 11.2.1 The HPLC system is assembled and calibrated as described in Section 12. The operating parameters are as follows:

Column: C-18 RP

Mobile Phase: 30% acetonitrile/70% distilled water

Detector: ultraviolet, operating at 254-nm

Flow Rate: 1 mL/min

Before each analysis, the detector baseline is checked to ensure stable operation.

- 11.2.2 A 25- $\mu$ L aliquot of the sample, dissolved in HPLC mobile phase, is drawn into a clean HPLC injection syringe. The sample injection loop is loaded and an injection is made. The data system is activated simultaneously with the injection and the point of injection is marked on the strip-chart recorder.

- 11.2.3 After approximately one minute, the injection valve is returned to the "load" position and the syringe and valve are flushed with mobile phase in preparation for the next sample analysis.
- 11.2.4 After elution of carbanilide, data acquisition is terminated and the component concentrations are calculated as described in Section 13.
- 11.2.5 Once a stable baseline is achieved, the system can be used for further sample analyses as described above.
- 11.2.6 If the concentration of carbanilide exceeds the linear range of the instruments, the sample should be diluted with mobile phase, or a smaller volume can be injected into the HPLC.
- 11.2.7 If the retention time is not duplicated, as determined by the calibration curve, you may increase or decrease the acetonitrile/water ratio to obtain the correct elution time, as specified in Figure 4. If the elution time is too long, increase the ratio; if it is too short, decrease the ratio.
- 11.2.8 If a dirty column causes improper detection of carbanilide, you may reactivate the column by reverse solvent flushing utilizing the following sequence: water, methanol, acetonitrile, dichloromethane, hexane, acetonitrile, then 50/50 acetonitrile in water.

## 12. HPLC Assembly and Calibration

- 12.1 The HPLC system is assembled and operated according to the parameters outlined in Section 11.2.1. An example of a typical chromatogram obtained using the above parameters is shown in Figure 4.
- 12.2 The mobile phase is prepared by mixing 500 mL of acetonitrile and 500 mL of reagent water. This mixture is filtered through a 0.22-um polyester membrane filter in an all-glass and Teflon suction filtration. A constant back pressure restrictor (50 psi) or short length (6-12 inches) of 0.01-inch I.D. Teflon tubing should be placed after the detector to eliminate further mobile phase outgassing.

- 12.3 The mobile phase is placed in the HPLC solvent reservoir and the pump is set at a flow rate of 1 mL/minute and allowed to pump for 20-30 minutes before the first analysis. The detector is switched on at least 30 minutes before the first analysis and the detector output is displayed on a strip-chart recorder or similar output device at a sensitivity of ca 0.008 absorbance units full scale (AUFS). Once a stable baseline is achieved, the system is ready for calibration.
- 12.4 Carbanilide standards are prepared in HPLC mobile phase. A concentrated stock solution of 100 mg/L is prepared by dissolving 10 mg of carbanilide in 100 mL of mobile phase. This solution is used to prepare calibration standards containing concentrations of 0.05-5 mg/L.
- 12.5 Each calibration standard (at least five levels) is analyzed three times and area response is tabulated against mass injected. All calibration runs are performed as described for sample analyses in Section 11. Using the UV detector, a linear response range (Figures 5a through 5e) of approximately 0.1 to 10 mg/L should be achieved for a 25- $\mu$ L injection volumes. The results may be used to prepare a calibration curve, as illustrated in Figure 6. Linear response is indicated where a correlation coefficient of at least 0.999 for a linear least-squares fit of the data (concentration versus area response) is obtained.
- 12.6 Once linear response has been documented, an intermediate concentration standard near the anticipated levels for ambient air, but at least 10 times the detection limit, should be chosen for daily calibration. The response for carbanilide should be within 10% day to day. If greater variability is observed, more frequent calibration may be required to ensure that valid results are obtained or a new calibration curve must be developed from fresh standards.
- 12.7 The response for carbanilide in the daily calibration standard is used to calculate a response factor according to the following equation:

$$RF_C = \frac{C_C \times V_I}{R_C}$$

where

$RF_C$  = response factor (usually area counts) for carbanilide in nanograms injected/response unit.

$C_C$  = concentration (mg/L) of carbanilide in the daily calibration standard.

$V_I$  = volume (uL) of calibration standard injected.

$R_C$  = response (area counts) for carbanilide in calibration standard.

### 13. Calculations

- 13.1 The volume of air sampled is often reported uncorrected for atmospheric conditions (i.e., under ambient conditions). The value should be adjusted to standard conditions (25°C and 760 mm pressure) using the following equation:

$$V_S = V_m \times \frac{P_A}{760} \times \frac{298}{273 + T_A}$$

where

$V_S$  = total sample volume (L) at 25°C and 760 mm Hg pressure.

$V_m$  = total sample volume (L) under ambient conditions, calculated as in Section 10.9 or from dry gas meter reading.

$P_A$  = ambient pressure (mm Hg).

$T_A$  = ambient temperature (°C).

- 13.2 The concentration of carbanilide is calculated for each sample using the following equation:

$$W_d = RF_C \times R_d \times \frac{V_E}{V_I}$$

where

- $W_d$  = total quantity of carbanilide ( $\mu\text{g}$ ) in the sample.  
 $RF_C$  = response factor calculated in Section 12.7.  
 $R_d$  = response (area counts or other response units) for carbanilide in sample extract.  
 $V_E$  = final volume (mL) of sample extract.  
 $V_I$  = volume ( $\mu\text{L}$ ) of extract injected into the HPLC system.

- 13.3 The concentration of phosgene in the original sample is calculated from the following equation:

$$C_A = \frac{W_d}{V_m \text{ (or } V_s)} \times \frac{99}{212} \times 1000$$

where

- $C_A$  = concentration of phosgene (ng/L) in the original sample.  
 $W_d$  = total quantity of carbanilide ( $\mu\text{g}$ ) in sample.  
 $V_m$  = total sample volume (L) under ambient conditions.  
 $V_c$  = total sample volume (L) at 25 °C and 760 mm Hg.  
 99 = the molecular weights (g/mole) of phosgene and  
 212 = carbanilide are 99 and 212 g/mole, respectively.

- 13.4 The phosgene concentrations can be converted to ppbv using the following equation:

$$C_A (\text{ppbv}) = C_A (\text{ng/L}) \times \frac{24.4}{99}$$

where

$C_A$  (ng/L) is calculated using  $V_s$ .

#### 14. Performance Criteria and Quality Assurance

This section summarizes required quality assurance (QA) measures and provides guidance concerning performance criteria that should be achieved within each laboratory.

##### 14.1 Standard Operating Procedures (SOPs).

14.1.1 Users should generate SOPs describing the following activities in their laboratory: 1) assembly, calibration, and operation of the sampling system with make and model of equipment used; 2) preparation, purification, storage, and handling of sampling reagent and samples; 3) assembly, calibration, and operation of the HPLC system with make and model of equipment used; and 4) all aspects of data recording and processing, including lists of computer hardware and software used.

14.1.2 SOPs should provide specific stepwise instructions and should be readily available to and understood by the laboratory personnel conducting the work.

##### 14.2 HPLC System Performance

14.2.1 The general appearance of the HPLC chromatogram should be similar to that illustrated in Figure 4.

14.2.2 The HPLC system efficiency and peak asymmetry factor should be determined in the following manner:

A solution of carbanilide corresponding to at least 20 times the detection limit should be injected with the recorder chart sensitivity and speed set to yield a peak approximately 75% of full scale and 1 cm wide at half height. The peak asymmetry factor is determined as shown in Figure 7, and should be between 0.8 and 1.8.

14.2.3 HPLC system efficiency is calculated according to the following equation:

$$N = 5.54 \frac{t_r}{W_{1/2}}$$

where

- N = column efficiency (theoretical plates).
- $t_r$  = retention time (seconds) of carbanilide.
- $W_{1/2}$  = width of component peak at half height (seconds).

A column efficiency of >5,000 theoretical plates should be obtained.

14.2.4 Precision of response for replicate HPLC injections should be +10% or less, day to day, for calibration standards. Precision of retention times should be +2% on a given day.

### 14.3 Process Blanks

14.3.1 Before use, a 10-mL aliquot of each batch of sampling reagent should be analyzed as described in Section 11. The blank should contain less than 50 ng of carbanilide per 10-mL aliquot.

14.3.2 At least one field blank or 10% of the field samples, whichever is larger, should be shipped and analyzed with each group of samples. The field blank is treated identically to the samples except that no air is drawn through the reagent. The same performance criteria described in Section 14.3.1 should be met for process blanks.

#### 14.4 Method Precision and Recovery

14.4.1 Analysis of replicate samples indicates that a precision of  $\pm 15-20\%$  relative standard deviation can be readily achieved (see Table 1). Each laboratory should collect parallel samples periodically (at least one for each batch of samples) to document its precision in conducting the method.

14.4.2 Precision for replicate HPLC injections should be  $\pm 10\%$  or better, day to day, for calibration standards.

14.4.3 Before using the method in the field, each laboratory must confirm the performance of the method under its particular conditions. Since static, dilute, gas phase standards of phosgene are unstable, a dynamic flow/permeation tub system should be assembled as described in the literature<sup>(1)</sup>. ASTM Method D.3609<sup>(3)</sup> should be used as the protocol for operating such a system.

14.4.4 Once a suitable dynamic flow/permeation tube system has been constructed, a series of three samples from the outlet gas stream (60 L) should be sampled at three different spike levels (achieved by adjusting the air flow through the permeation chamber). Precision and recovery data comparable to those shown in Table 1 should be achieved.

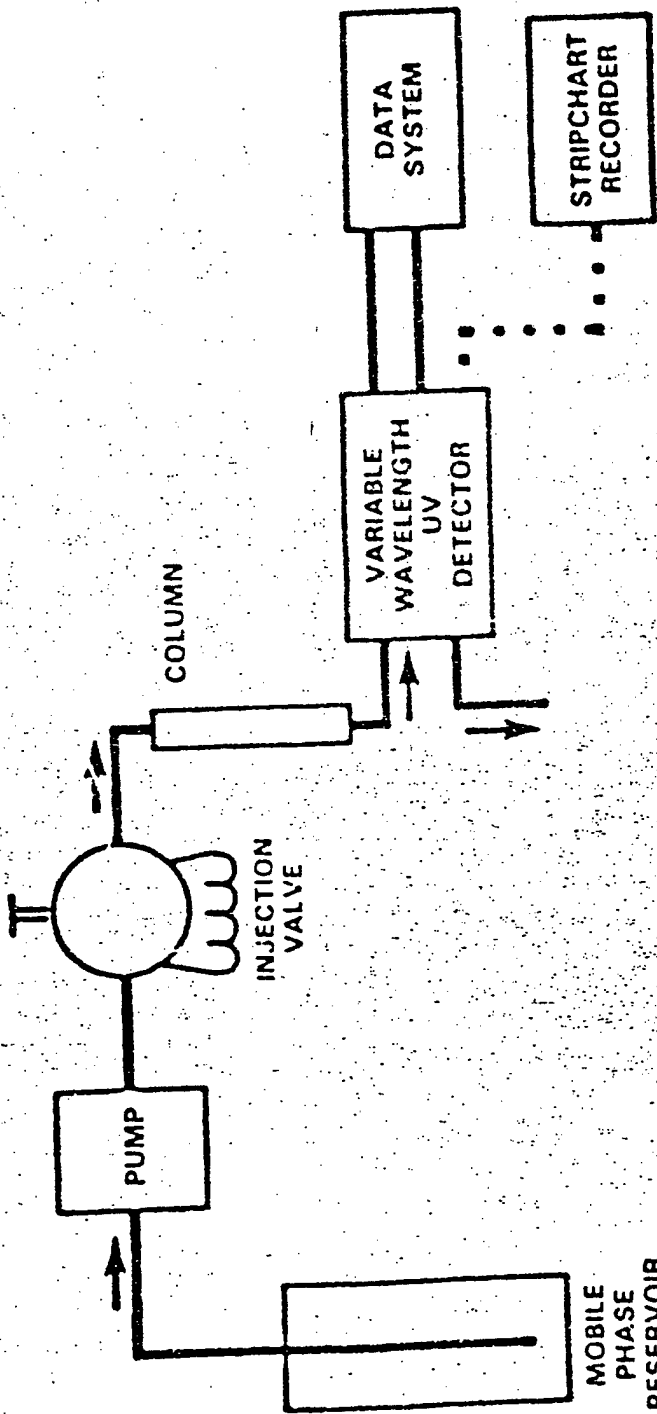

FIGURE 1. TYPICAL HPLC SYSTEM

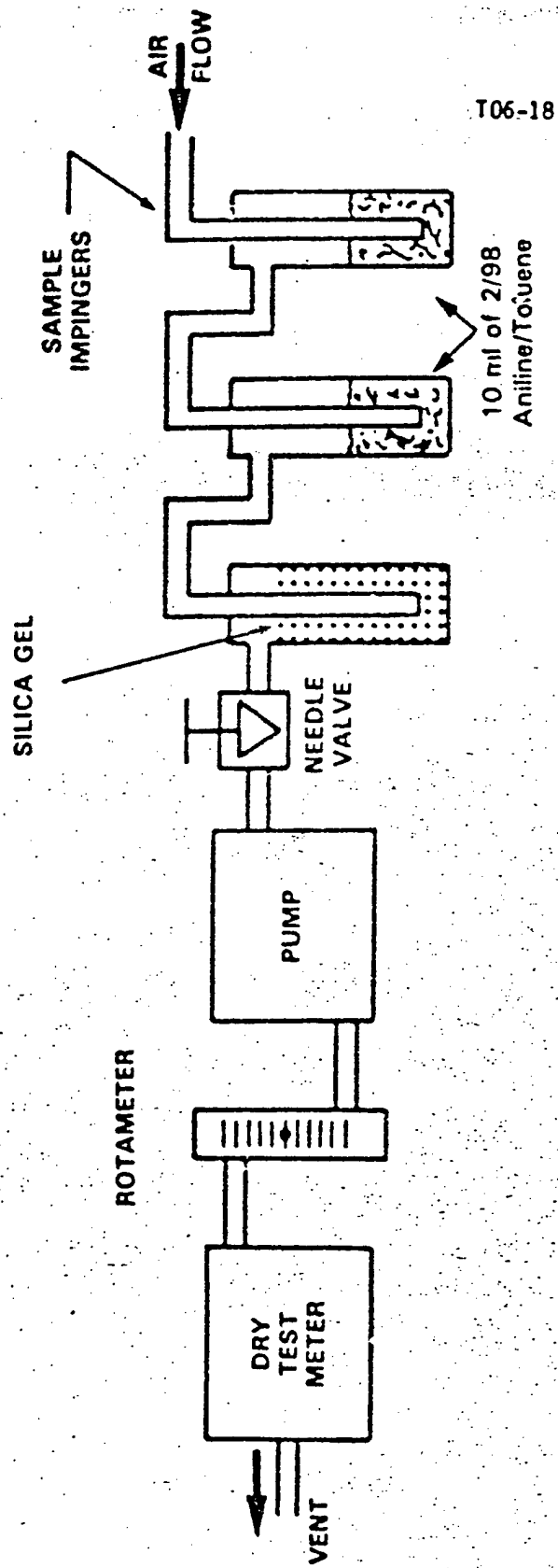

FIGURE 2. TYPICAL SAMPLING SYSTEM FOR MONITORING PHOSGENE IN AMBIENT AIR

T06-19

**SAMPLING DATA SHEET**  
(One Sample per Data Sheet)

PROJECT: \_\_\_\_\_

DATES(S) SAMPLED: \_\_\_\_\_

SITE: \_\_\_\_\_

TIME PERIOD SAMPLED: \_\_\_\_\_

LOCATION: \_\_\_\_\_

OPERATOR: \_\_\_\_\_

INSTRUMENT MODEL NO: \_\_\_\_\_

CALIBRATED BY: \_\_\_\_\_

PUMP SERIAL NO: \_\_\_\_\_

SAMPLING DATA

Sample Number: \_\_\_\_\_

Start Time: \_\_\_\_\_

Stop Time: \_\_\_\_\_

Time	Dry Gas Meter Reading	Rotameter Reading	Flow Rate, $Q$ mL/min	Ambient Temperature, $^{\circ}C$	Barometric Pressure, mm Hg	Relative Humidity, %	Comments
1.							
2.							
3.							
4.							
N.							

Total Volume Data\*\*

$V_m = (\text{Final} - \text{Initial})$  Dry Gas Meter Reading, or \_\_\_\_\_ L

$$\frac{Q_1 + Q_2 + Q_3 + \dots + Q_N}{N} \times 1000 \times (\text{Sampling Time in Minutes}) = \text{_____ L}$$

\* Flow rate from rotameter or soap bubble calibrator (specify which).

\*\* Use data from dry gas meter if available.

**FIGURE 3. TYPICAL SAMPLING DATA FORM**

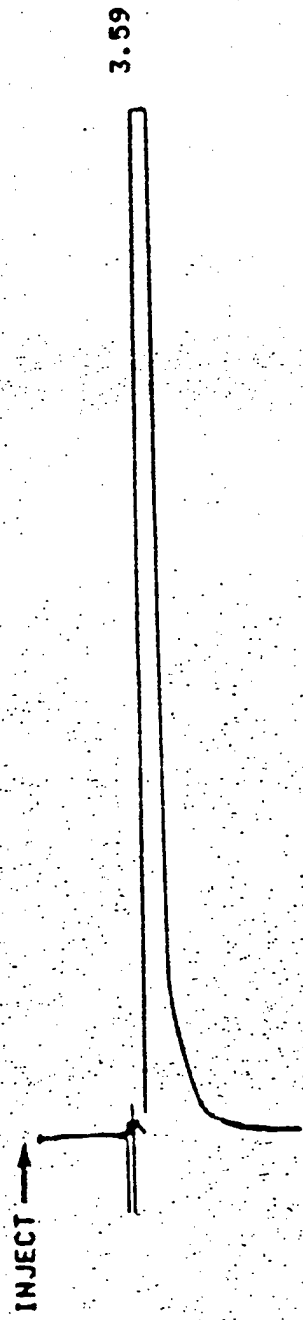

OPERATING PARAMETERS  
HPLC

Column: C-18 RP  
Mobile Phase: 30% Acetonitrile/70% Distilled Water  
Detector: Ultra violet operating at 254 nm  
Flow Rate: 1 ml/min  
Retention Time: 3.59 minutes

AUG 22 1986 15 25 17 CHART 0.50 CM-MIN  
RUN #50 CALC #0  
COLUMN SOLVENT OPR ID

EXTERNAL STANDARD QUANTITATION

PEAK #	AMOUNT	RT	EXP RT	AREA	RF
	2.75300	2.74		2753 L	0.000000E0
	10020.20000	3.59		10020345 L	0.000000E0
TOTAL	10023.00000				

FIGURE 4. CHROMATOGRAM FOR 3 ppbv OF PHOSGENE SPIKED INTO CLEAN AIR

T06-21

OPERATING PARAMETERS  
HPLC

Column: C-18 RP  
Mobile Phase: 30% Acetonitrile/70% Distilled Water  
Detector: Ultra violet operating at 254 nm  
Flow Rate: 1 ml/min  
Retention Time: 3.59 minutes

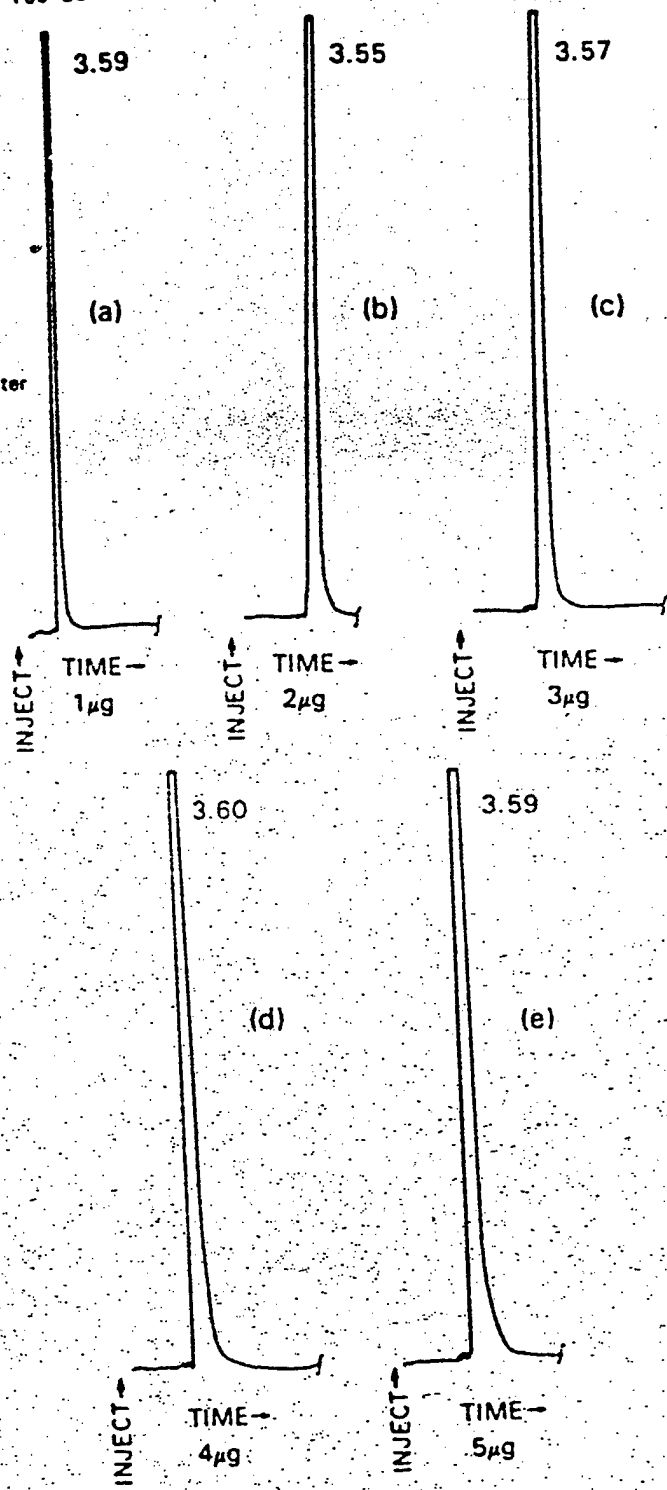

CONC	AREA COUNTS
1 μg	2126577
2 μg	4243289
3 μg	6312128
4 μg	8373790
5 μg	10020345

FIGURE 5a-5e. HPLC CHROMATOGRAM OF VARYING CARBANILIDE CONCENTRATIONS

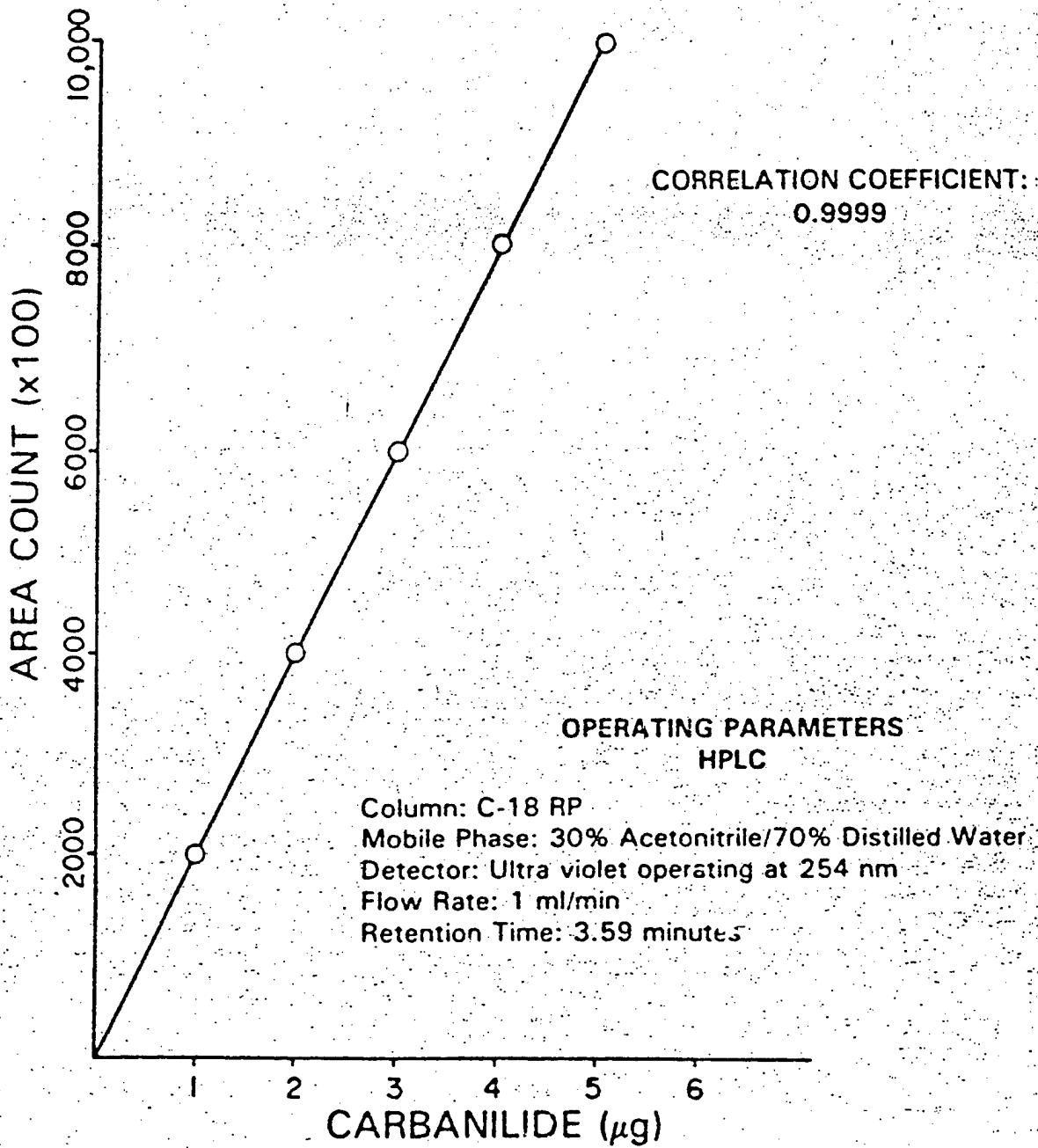
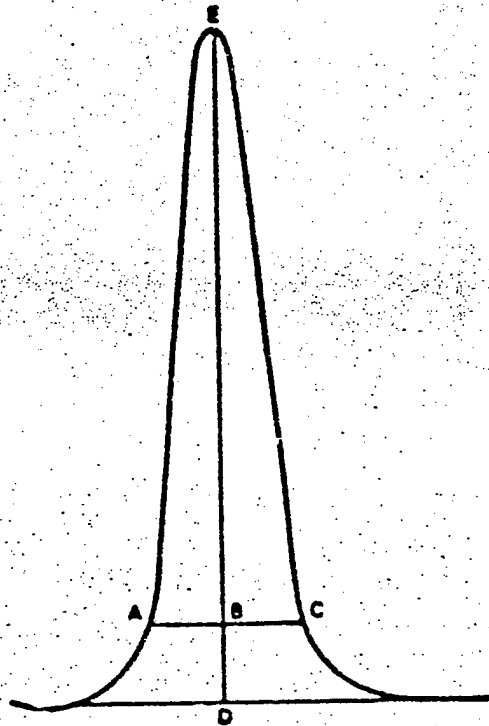

FIGURE 6. CALIBRATION CURVE FOR CARBANILINE

T06-23



$$\text{Asymmetry Factor} = \frac{BC}{AB}$$

Example Calculation:

Peak Height = DE = 100 mm

10% Peak Height = BD = 10 mm

Peak Width at 10% Peak Height = AC = 23 mm

AB = 11 mm

BC = 12 mm

$$\text{Therefore: Asymmetry Factor} = \frac{12}{11} = 1.1$$

FIGURE 7. PEAK ASYMMETRY CALCULATION

TABLE 1: PRECISION AND RECOVERY DATA  
FOR PHOSGENE IN CLEAN AIR

Phosgene Concentration, ppbv	Recovery, %	Standard Deviation
0.034	63	13
0.22	87	14
3.0	99	3
4.3	109	12
20	99	14
200	96	7

**NIOSH METHOD S8**

## OZONE

---

Analyte:	Ozone	Method No.:	S8
Matrix:	Air	Range:	0.1-0.4 mg/cu m
OSHA Standard:	0.1 ppm (0.2 mg/cu m)	Precision ( $CV_T$ ) =	0.0806
Procedure:	Colorimetric-Alkaline KI Method	Validation Date:	10/11/74

---

### 1. Principle of the Method

- 1.1 Air containing ozone is drawn through a midget impinger containing 10 ml of 1 percent potassium iodide in 1 N sodium hydroxide. A stable product is formed that can be stored with little loss for several days.
- 1.2 The analysis is completed in the laboratory by the addition of phosphoric-sulfamic acid reagent, which liberates the iodine.
- 1.3 The yellow iodine color is read in a spectrophotometer at 352 nm.

### 2. Range and Sensitivity

- 2.1 This method has been validated over the range 0.1 to 0.4 mg/cu m. This is the limit of the useful range for the 45 liter sample size. The method is capable of measuring smaller or larger concentrations if the sampling size is adjusted, but it has not been validated for other sample sizes.

### 3. Interferences

- 3.1 Chlorine, hydrogen peroxide, organic peroxides, and various other oxidants will liberate iodine by this method.
- 3.2 The response to nitrogen dioxide is limited to 10 percent by the use of sulfamic acid in the procedure to destroy nitrite, thus minimizing any error due to the collection of  $NO_2$ .
- 3.3 The negative interferences from reducing gases such as sulfur dioxide and hydrogen sulfide are very serious (probably on a mole-to-mole equivalency).
- 3.4 The procedure is very sensitive to reducing dusts that may be present in the air or on the glassware. Losses of iodine also occur even on clean glass surfaces and thus the manipulations should minimize this exposure.

#### 4. Precision and Accuracy

- 4.1 The Coefficient of Variation ( $CV_T$ ) for the total analytical and sampling method in the range of 0.1 to 0.4 mg/cu m is 0.0806. The standard deviation at the OSHA standard level is 0.0077 mg/cu m. Statistical information and details of the validation and experimental test procedures can be found in Reference 11.2.
- 4.2 On the average, the values obtained using the overall sampling and analytical method were the same as the true value at the OSHA standard level.
- 4.3 These data are based on validation experiments in which neutral buffered KI was used to determine the actual ozone concentration.

#### 5. Advantages and Disadvantages of the Method

- 5.1 The method is simple, accurate and precise.
- 5.2 Those compounds listed in 3.1 will liberate iodine by this method.
- 5.3 A delay of several days is permissible between sampling and completion of analysis. However, the relationship between delay and analytical results has not been established.

#### 6. Apparatus

- 6.1 Midget impinger with 1 mm ID nozzle, graduation marks and Teflon-coated ground glass stopper.
- 6.2 Personal sampling pump capable of drawing the required sample flow for intervals of up to 45 minutes.
- 6.3 Air metering device capable of measuring a flow of 1 to 2 liters per minute, including a prefilter to prevent liquid droplets from reaching the measuring device.
- 6.4 Spectrophotometer capable of measuring the yellow color at 352 nm with stoppered tubes or cuvettes.
- 6.5 Associated laboratory glassware.

#### 7. Reagents

The reagents described must be made up using ACS reagent grade or better grade of chemical.

- 7.1 Double distilled water.
- 7.2 Absorbing reagent. Dissolve 40.0 g of sodium hydroxide in almost a liter of water, then dissolve 10.0 g of potassium iodide and

make the mixture to 1 liter. Store in a clean glass bottle with a screw cap (with inert liner) or rubber stopper (previously boiled for 30 minutes in alkali and washed). Age for at least 1 day before using. The reagent should be used within two weeks.

7.3 Acidifying reagent. Dissolve 5.0 g of sulfamic acid in 100 ml of water, then add 84 ml of 85 percent phosphoric acid and dilute to 200 ml.

7.4 Standard potassium iodate solution. Dissolve 0.758 g of potassium iodate in water and dilute to 1 liter. One ml of this stock solution is equivalent to 400  $\mu$ l of ozone. Prepare a dilute standard solution just before it is required by pipetting exactly 5 ml of stock solution into a 50-ml volumetric flask and making to mark with distilled water.

## 8. Procedure

8.1 Cleaning of equipment. All glassware should be cleaned with dichromate cleaning solution followed by 3 tap and 3 distilled water rinses.

### 8.2 Collection of samples

8.2.1 Assemble a train composed of a midget impinger, a rotameter, and pump. Use ground glass connections upstream from the impinger. Insure that all fittings are vacuum tight.

8.2.2 Pipette exactly 10 ml of the absorbing solution into the midget impinger and sample at a flow rate of 1 liter per minute. Note the volume of air sampled. Record atmospheric temperature and pressure.

8.2.3 Cap the impinger with the stopper supplied for shipment to the laboratory.

### 8.3 Analysis

8.3.1 If the liquid level is below the 10-ml mark in the impinger, add distilled water to bring the level up to the mark.

8.3.2 Add 2 ml of the acidifying reagent with a volumetric pipette. Swirl gently to expel the carbon dioxide released immediately. Then cap and shake vigorously until bubbling ceases. It is imperative that all of the carbon dioxide is expelled, otherwise more may be released while the u.v. measurement is being made.

8.3.3 Place the stoppered impinger in a water bath at room temperature for 5 to 10 minutes to dissipate the heat of neutralization.

- 8.3.4 Transfer a portion of the sample to a cuvette and determine the absorbance at 352 nm. A cuvette containing distilled water is used as the reference. Do not delay the reading since reducing impurities sometimes causes rapid fading of the color.
- 8.3.5 Prepare a reagent blank by adding 2 ml of the acidifying reagent to ml of unexposed absorbing reagent. Cool and determine the blank absorbance. The blank absorbance should be determined each day and should be subtracted from the absorbance of the samples.
- 8.3.6 Samples may be aliquoted before or after acidification if very large concentrations of oxidant are expected. In the former case dilute the aliquot to 10 ml with unexposed absorbing reagent and proceed in the usual manner. In the latter case dilute the aliquot to 10 ml with reagent blank mixture. Aliquoting after acidification is not as reliable as before acidification and should be used only to save a sample when unexpectedly large concentrations of oxidant are encountered. The calculations should include the aliquoting factor.

## 9. Calibration and Standards

- 9.1 Add the freshly prepared, dilute standard iodate solution in graduated amounts of 0.10 to 0.5 ml (measured accurately in a graduated pipette or small burette) to a series of 25-ml glass stoppered volumetric flasks. Make at least 4 standards.
- 9.2 Add alkaline potassium iodide solution (measured accurately in a graduated pipette) to make the total volume of each exactly 10 ml.
- 9.3 Acidify and determine the absorbance of each standard as with the samples.

## 10. Calculations

- 10.1 Plot the absorbance of the standards (corrected for the blank) against the concentration of dilute standard iodate solution. One (1) ml of the diluted standard iodate solution (in a total of 10-ml absorbing solution per Section 9) is equivalent to 51 mg of ozone. To readily determine ambient ozone concentrations in units of  $\text{mg}/\text{m}^3$ , it is convenient to plot absorbance versus mg equivalents of ozone per 10 ml of absorbing solution.
- 10.2 Upon determining the absorbance of the sample solutions, use the standard absorbance curve to find the ozone equivalence. The concentration of ozone in the air sample equals the ozone equivalence divided by the air volume in liters.

$$O_3 \text{ (mg/m}^3\text{)} = \frac{\text{ozone equivalence}}{\text{air volume (liters)}}$$

The reaction of ozone with alkaline KI is not quantitative and the yield of iodine is concentration dependent. The following correction equation was developed during validation of the method.

$$O_3 \text{ (mg/cu m)} = 0.038 + 1.038A - 0.010505A^2$$

where A is the concentration of ozone (also in mg/cu m) read from the absorbance curve.

- 10.3 Another method of expressing concentration is ppm, defined as  $\mu\text{l}$  of ozone per liter of air

$$\text{ppm } O_3 = O_3 \text{ (mg/cu m)} \times \frac{24.45}{48} \times \frac{760}{P} \times \frac{T + 273}{298}$$

where:

- P = pressure (mm Hg) of air sampled
- T = temperature (C) of air sampled
- 24.45 = molar volume (l/mole) at 25 C and 760 mm Hg
- 48 = molecular weight (g/mole) of ozone
- 760 = standard pressure (mm Hg)
- 298 = standard temperature (K)

## 11. References

- 11.1 "Selected Methods for the Measurement of Air Pollutants" USDHEW Public Health Service Publication Number 999-AP-11, 1965.
- 11.2 "Documentation of NIOSH Validation Tests", Contract No. CDC-99-74-45.

# **Appendix C**

## **TEMPORARY SHED SPECIFICATIONS**



September 23, 1998

Jerrold Davis  
 Metcalf & Eddy  
 25 Main Street  
 Chico, CA 95928

Dear Mr. Davis,

Please consider the following quotation.

**PROPOSAL For Metcalf & Eddy:**

ITEM	QTY	DESCRIPTION	PRICE
Vinyl Shelter	1	20' Wide X 20' Long X 16' Center Height X 13' Side wall • 180Z. Cover, Translucent White, Flame Retardant Fabric Meeting State of CA Fire Marshall and NFPA 701 • Frame Members: 2.375" Heavy Wall, Single Bow, Galvanized Tubular Steel • Each Bow on 04' Centers • Full Length Base Beam With Welded Uprights to Accept the Bows • Designed for 15 PSF Snow Load • 75 MPH Wind Load • Welded Anchor Plates Provided for a Concrete Foundation. Concrete Lag Bolts Included • Fabric Ends 4' Above the Ground Level. • All Weld Joints Coated With 97% Zinc to Retard Rusting	\$ 2,570.00
End Panels		Open Ends	
Installation		By End User. Should Budget 5 Hours With 3 People	
Shipping		F.O.B. McClellan AFB Sacramento, CA	INCLUDED
<b>GRAND TOTAL</b>			<b>\$ 2,570.00</b>

Optional: Crane Lifting Ability, Casters for Movement, HEPA Connections, Metal Entry Doors, Exhaust Fan Systems, etc.

Payment Terms: 50% Down in Advance. Balance is due upon delivery or ship date.

Lead Time: 07-13 Working Days

- All assembly instructions, hardware, and anchors are included with shipment.

Sincerely,

*G. W. Pridgcon*  
 G. W. Pridgcon  
 Sales Manager

Approved This Day of ,1998

By: P. O. #

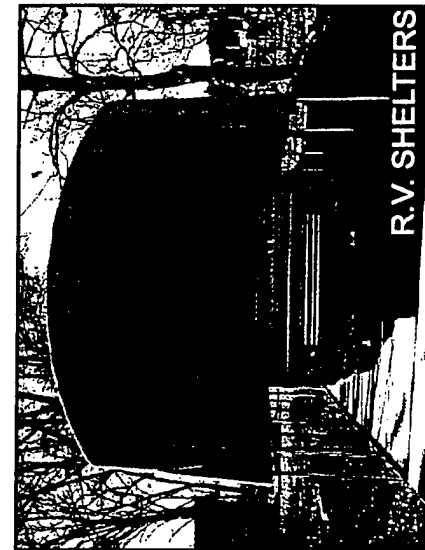

R.V. SHELTERS



PAINT BOOTH SHELTERS



BOAT LIFT SHELTERS

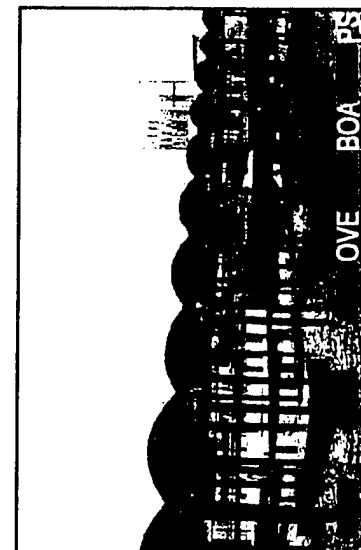

AIRPORT HANGARS

## PRICE GUIDE

Width X Height X Length	CENTER HEIGHT	LENGTH				
		20FT	30FT	40FT	50FT	60FT
12FT X 8FT X 20FT	8FT	\$1,187	\$1,781	\$2,374	\$2,968	\$3,561
16FT X 10FT X 20FT	10FT	\$1,647	\$2,471	\$3,294	\$4,118	\$4,941
20FT X 12FT X 20FT	12FT	\$3,033	\$4,550	\$6,066	\$7,583	\$9,099
24FT X 14FT X 20FT	14FT	\$3,128	\$4,692	\$6,256	\$7,820	\$9,384
28FT X 14FT X 20FT	14FT	\$4,053	\$6,080	\$8,106	\$10,133	\$12,159
32FT X 16FT X 20FT	16FT	\$4,072	\$6,108	\$8,144	\$10,180	\$12,216
36FT X 16FT X 20FT	16FT	\$4,220	\$6,330	\$8,440	\$10,550	\$12,660
40FT X 16FT X 20FT	16FT		\$6,696	\$8,928	\$11,160	\$13,392
52FT X 18FT X 20FT	18FT			\$17,640	\$22,050	\$26,460
60FT X 22FT X 20FT	22FT				\$25,178	\$30,214

**Over 5,000 Sizes Available • Widths Up to 135' • Call For A Quote**

Prices above reflect 75mph winds and 12psf snow loads. Clearance dimensions may be less than the outside width

**FRAME SPECIFICATIONS**

- 55,000 PSI Galvanized Steel Tubing
- 1.66' Round - 4.00' Square Depending On Shelter Size
- Tubing Thickness 10 GA - 16 GA

**FABRIC SPECIFICATIONS**

- 18-24 OZ. Laminated Polyester Reinforced Vinyl Membrane
- 24-32 OZ. Coated Polyester Reinforced Vinyl Membrane
- Flame Retardant / Tear Resistant
- Thermal Properties are -40° FH to 180° FH
- 10-20 Year Life Expectancy (Depending on Fabric Selected)

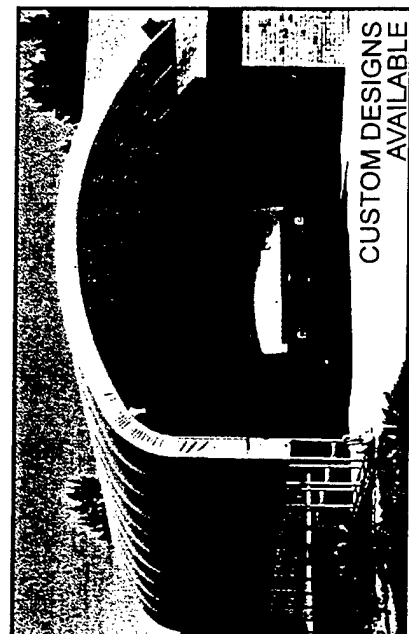

CUSTOM DESIGNS AVAILABLE



AIRPORT HANGARS



AIRPORT HANGARS

## TERMS

Unless otherwise stated, terms are 50% down with order and 50% upon delivery. Purchase orders from qualified businesses and government agencies will be accepted on an individual basis. MasterCard, Visa, and Discover Card are accepted as collateral only. Prices quoted are F.O.B. factory and are in U.S. currency. Allow 10-20 working days for production of standard buildings. Rush shipments are available based on current production levels. Prices are subject to change without notification. Factory direct pricing is only available to areas without a local distributor.

## LEASING PROGRAM

- ✓ 100% Financing
- ✓ Low Monthly Payments
- ✓ 24 Hour Approval
- ✓ Processed Promptly and Confidentially
- ✓ Flexible Payment Terms
- ✓ Preserves Cash Flow
- ✓ Tax Savings
- ✓ Fixed Rates

## Customers Worldwide

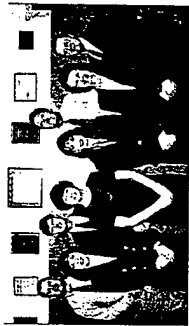

*"We're Here To Serve You!"  
We Appreciate Your Business!"*

**Manufactured in the U.S.A. Since 1978**

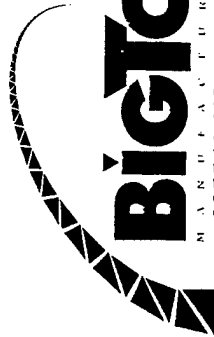

3255 N. US 19  
Perry, Florida 32347 USA  
1-800-277-8677 • FAX 1-850-584-7713  
011-850-584-7786 International  
www.bigtopshelters.com  
e-mail: sales@bigtopshelters.com

# Bigtop

MANUFACTURING

*Price Guide & Specifications*

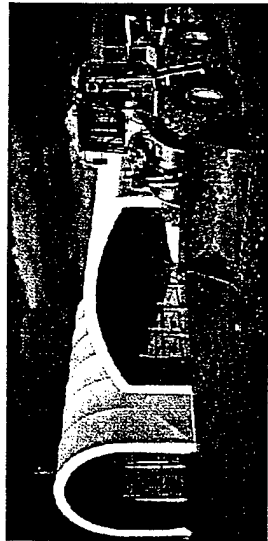
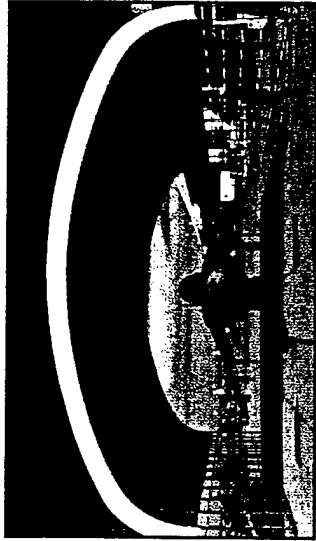
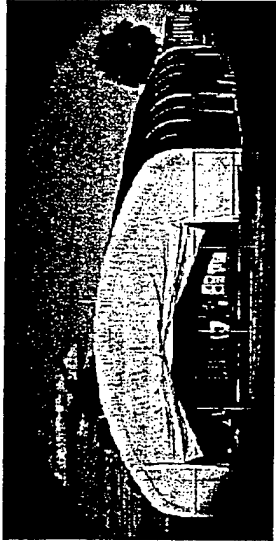

## PORTABLE VINYL SHELTERS

## BUY FACTORY DIRECT

# SHUTTERS *With Custom* SYSTEMS

- COMPLETELY RELOCATABLE
- NO FOUNDATION REQUIRED
- FULL ENGINEERING SERVICES
- DESIGNED FOR WINDLOADS UP TO 120 MPH (193 KM/H)
- DESIGNED FOR SNOWLOADS UP TO 40 LBS/SQ. FT.
- LONG TERM DURABILITY
- PROVEN TRUSS TECHNOLOGY
- SPEED OF DELIVERY
- ERECTS QUICKLY & EASILY
- INTERCHANGABLE FRAME COMPONENTS
- 5-YEAR WARRANTY
- SHIPPED IN KIT FORM
- TECH SUPPORT AVAILABLE
- LEASE OR PURCHASE

# ON AMERICA

# RELOCATABLE MAINTENANCE SHELTERS

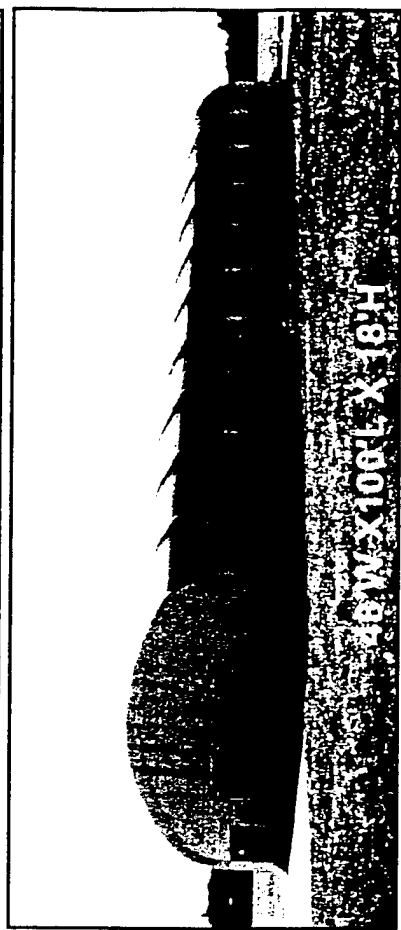
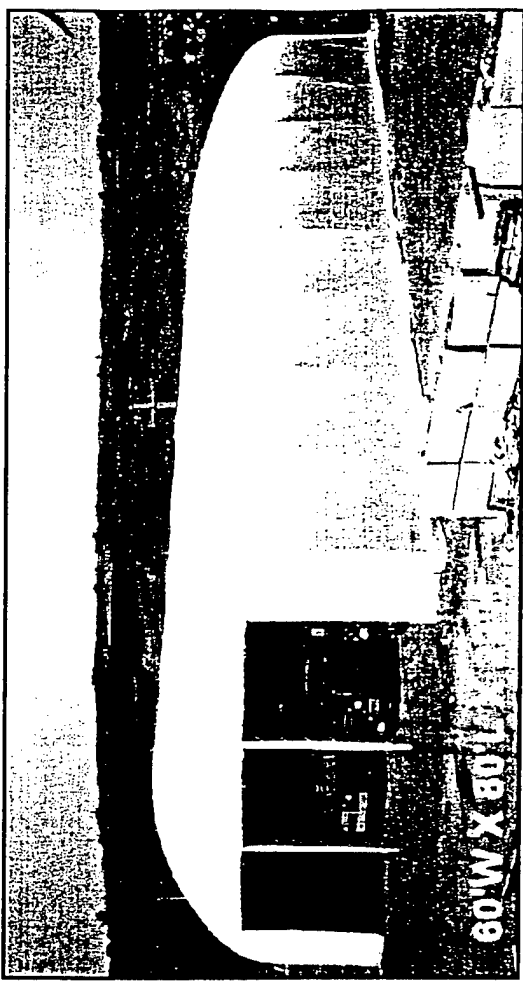
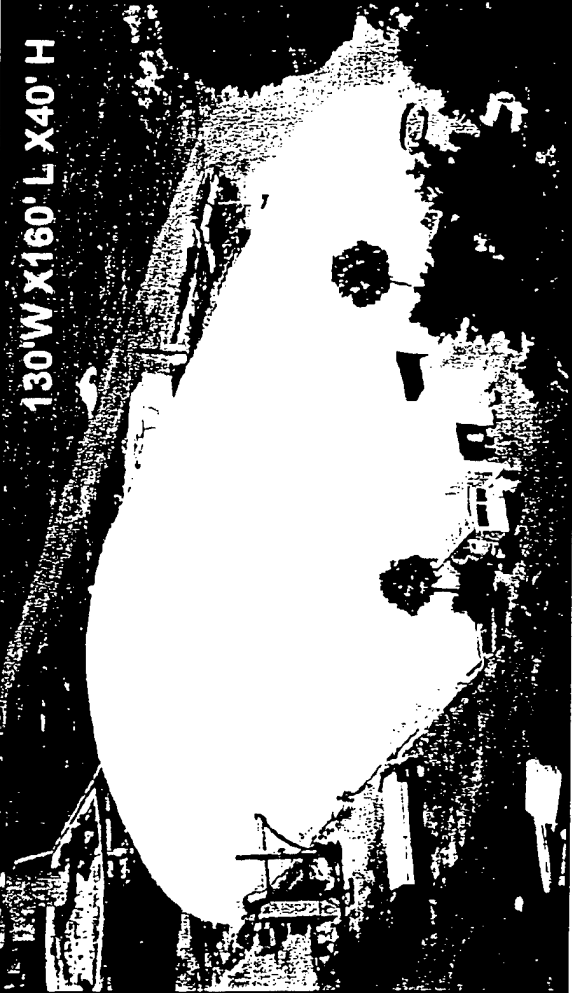

## BigTop

M A N U F A C T U R I N G

(800) 277-8677 • (904) 584-7786 • Fax (904) 584-7713  
3255 N. U.S. 19 • Perry, FL USA  
[www.bigtopshelters.com](http://www.bigtopshelters.com) • e-mail: [sales@bigtopshelters.com](mailto:sales@bigtopshelters.com)

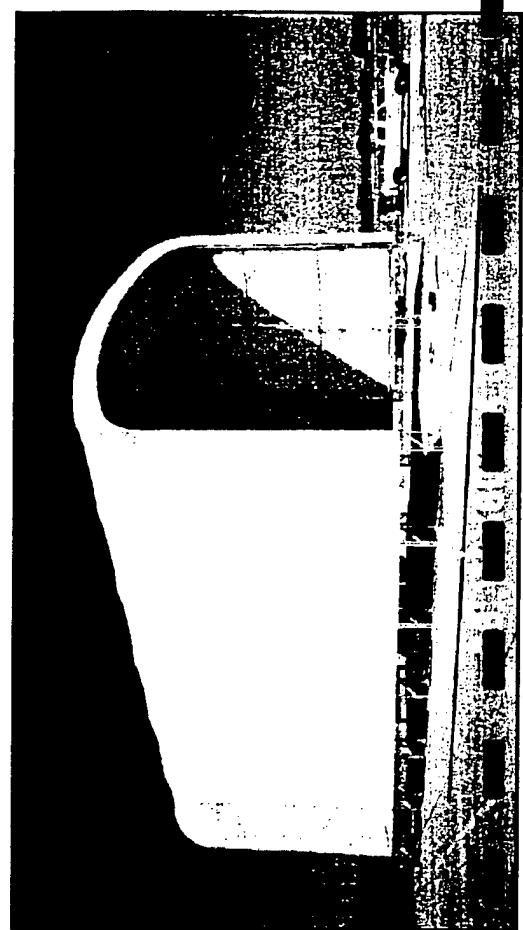
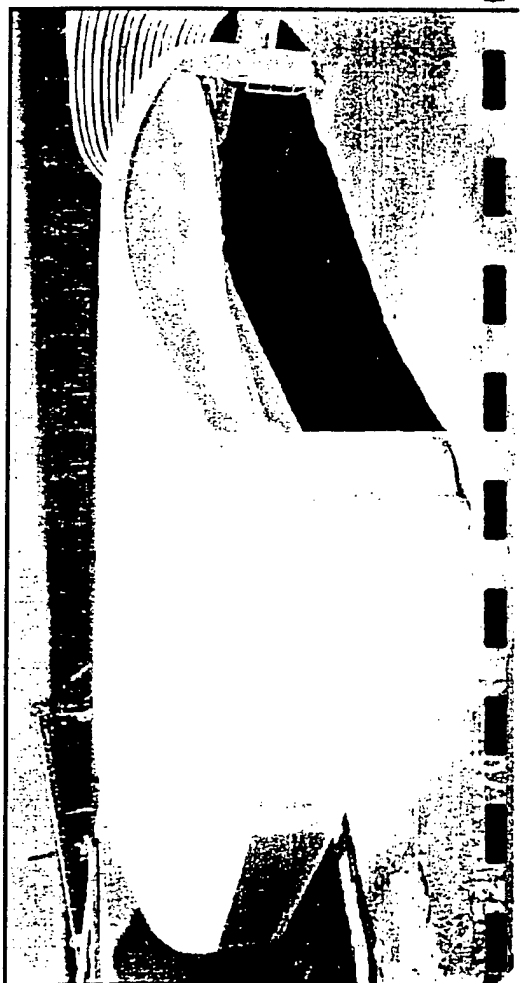

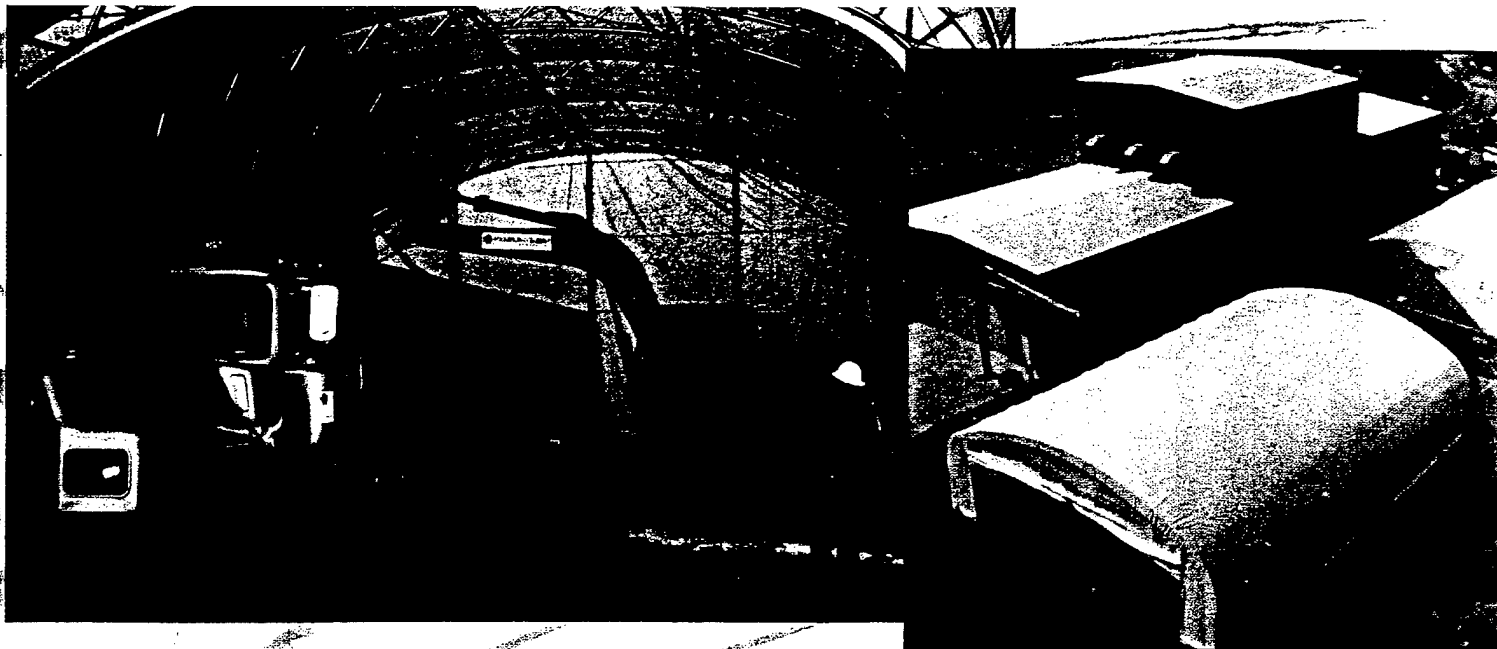

# C O N S T R U C T I O N / E N V I R O N M E N T A L P R O T E C T I O N

**Big Top** provides simple solutions to common problems in the construction and environmental industry. Environmental issues and compliance are ever changing and so are the materials and equipment that are associated with the industry. Because of its temporary nature the construction marketplace requires a low cost temporary structure. However, these structures must be rugged enough to survive the rigors of the construction atmosphere. These clear span structures require little or no surface prepa-

ration. **Big Top shelters** can be modified or lifted with a crane in its fully erected state or can be quickly disassembled, relocated, and reassembled. Our structures are designed with the mindset of "SIMPLE BUT SOLID". Constructed with common components our shelters can be installed with one lead person and unskilled laborers. We can send a technical representative to lead your crew or install the complete kit. We include step-by-step illustrated assembly instructions with each package.

## A V I A T I O N

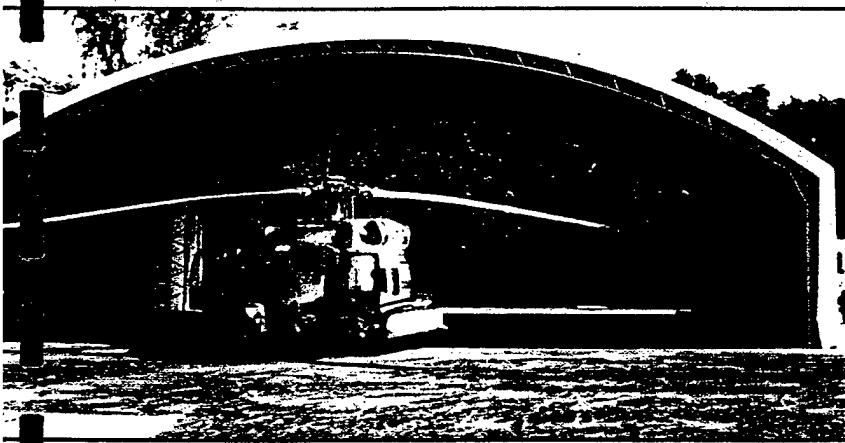

Our clear span modular shelters can house single or multiple aircraft with wing-spans from 30 feet (9meters) to 120 feet (36meters). We have a wide variety of sizes and options to customize our shelters. Our systems have been utilized throughout the world for aircraft maintenance facilities, storage, and support.

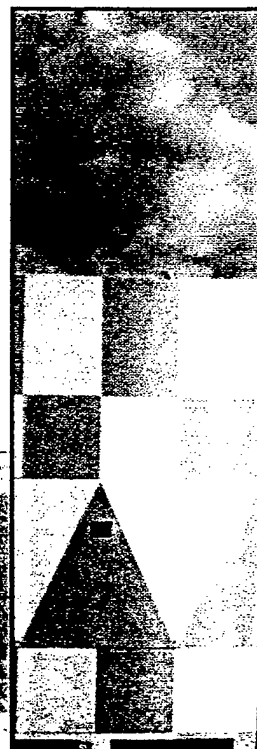

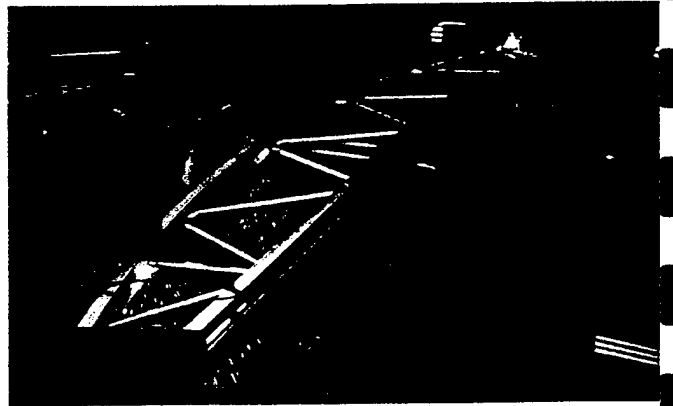
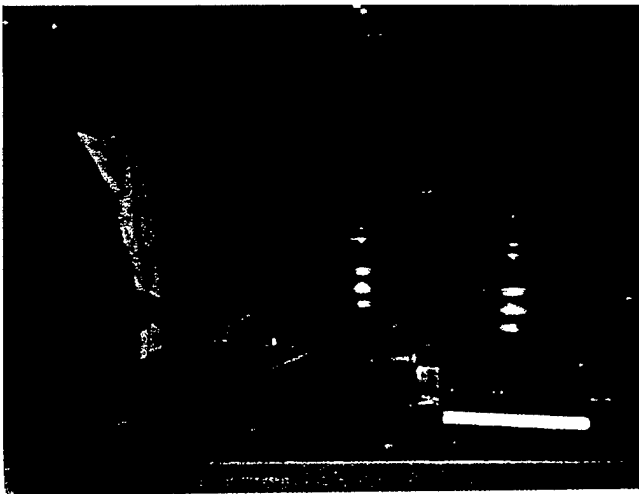

## **B I G T O P P R O F I L E**

Many Companies throughout the world have been utilizing our products and services for the past two decades. When confronted with the need for enclosed space, you can look to us for solutions.



**BIGTOP MANUFACTURING** is a leader in providing effective solutions for enclosing space economically and quickly in any climate. We specialize in fabricating structures that meet or exceed the requirements of our customers by using advanced technology and quality materials.

## **A P P L I C A T I O N S**

- On site warehousing
- Equipment storage
- Soil Remediation Enclosures
- Hazardous Excavation
- Negative Pressure Enclosures
- Waste Water Treatment

