

LOAN DOCUMENT

PHOTOGRAPH THIS SHEET

DTIC ACCESSION NUMBER

LEVEL

INVENTORY

①

Bioventing Test Work Plan & Interim ...
DOCUMENT IDENTIFICATION
Aug 94

DISTRIBUTION STATEMENT A
Approved for Public Release
Distribution Unlimited

DISTRIBUTION STATEMENT

DATE ACCESSIONED

DATE ACCESSIONED

DATE RETURNED

DATE RETURNED

REGISTERED OR CERTIFIED NUMBER

REGISTERED OR CERTIFIED NUMBER

ACCESSION FOR	
NTIS	GRAM <input checked="" type="checkbox"/>
DTIC	TRAC <input type="checkbox"/>
UNANNOUNCED JUSTIFICATION	
BY	
DISTRIBUTION/	
AVAILABILITY CODES	
DISTRIBUTION	AVAILABILITY AND/OR SPECIAL
A-1	

DISTRIBUTION STAMP

20001208 113

DATE RECEIVED IN DTIC

PHOTOGRAPH THIS SHEET AND RETURN TO DTIC-FDAC

H
A
N
D
L
E

W
I
T
H

C
A
R
E

DRAFT

**BIOVENTING TEST WORK PLAN AND
INTERIM TEST RESULTS REPORT FOR
FIRE TRAINING PIT 4 (FT-002)
PLATTSBURGH AIR FORCE BASE, NEW YORK**

Prepared For
**AIR FORCE CENTER FOR ENVIRONMENTAL EXCELLENCE
BROOKS AFB, TEXAS**

and

**380th CIVIL ENGINEERING SQUADRON AND
ENVIRONMENTAL MANAGEMENT BRANCH
PLATTSBURGH AFB, NEW YORK**

Prepared By
ENGINEERING-SCIENCE, INC.

August 1994

**290 Elwood Davis Road
Liverpool, New York 13088**

**ENGINEERING-SCIENCE
ES**

AQM01-03-0428

DEFENSE TECHNICAL INFORMATION CENTER REQUEST FOR SCIENTIFIC AND TECHNICAL REPORTS

Title AFCEE Collection

1. Report Availability (Please check one box)
 This report is available. Complete sections 2a - 2f.
 This report is not available. Complete section 3.

2a. Number of Copies Forwarded
1 each

2b. Forwarding Date
July/2000

2c. Distribution Statement (Please check ONE box)
DoD Directive 5230.24, "Distribution Statements on Technical Documents," 18 Mar 87, contains seven distribution statements, as described briefly below. Technical documents MUST be assigned a distribution statement.
 DISTRIBUTION STATEMENT A: Approved for public release. Distribution is unlimited.
 DISTRIBUTION STATEMENT B: Distribution authorized to U.S. Government Agencies only.
 DISTRIBUTION STATEMENT C: Distribution authorized to U.S. Government Agencies and their contractors.
 DISTRIBUTION STATEMENT D: Distribution authorized to U.S. Department of Defense (DoD) and U.S DoD contractors only.
 DISTRIBUTION STATEMENT E: Distribution authorized to U.S. Department of Defense (DoD) components only.
 DISTRIBUTION STATEMENT F: Further dissemination only as directed by the controlling DoD office indicated below or by higher authority.
 DISTRIBUTION STATEMENT X: Distribution authorized to U.S. Government agencies and private individuals or enterprises eligible to obtain export-controlled technical data in accordance with DoD Directive 5230.25, Withholding of Unclassified Technical Data from Public Disclosure, 6 Nov 84.

2d. Reason For the Above Distribution Statement (in accordance with DoD Directive 5230.24)

2e. Controlling Office
HQ AFCEE

2f. Date of Distribution Statement Determination
15 Nov 2000

3. This report is NOT forwarded for the following reasons. (Please check appropriate box)
 It was previously forwarded to DTIC on _____ (date) and the AD number is _____
 It will be published at a later date. Enter approximate date if known. _____
 In accordance with the provisions of DoD Directive 3200.12, the requested document is not supplied because:

Print or Type Name
Laura Peña
Telephone
210-536-1431

Signature
Laura Peña
(For DTIC Use Only)
AQ Number M01-03-0428

PART I
DRAFT BIOVENTING TEST WORK PLAN FOR
FIRE TRAINING PIT 1
AND
FIRE TRAINING PIT 4 AND OIL/WATER SEPARATOR
(FT-002)
PLATTSBURGH AFB, NEW YORK

Prepared for

Air Force Center for Environmental Excellence
Brooks AFB, Texas

and

380th Civil Engineering Squadron and
Environmental Management Branch
Plattsburgh AFB, New York

by

Engineering-Science, Inc
290 Elwood Davis Road
Liverpool, New York

February 1993

TABLE OF CONTENTS

1.0 Introduction	1
2.0 Site Description.....	2
2.1 Fire Training Pit Area - 002	2
2.1.1 Site Location and History	2
2.1.2 Site Geology	2
2.1.3 Site Contaminants	5
3.0 Pilot Test Activities	5
3.1 Introduction	5
3.2 Well Siting and Construction.....	7
3.2.1 Well Siting and Construction for Pit 1	7
3.2.2 Well Siting and Construction for Pit 4	10
3.3 Handling of Drill Cuttings.....	10
3.4 Soil and Soil Gas Sampling.....	10
3.4.1 Soil Sampling	10
3.4.2 Soil Gas Sampling	10
3.5 Blower System	12
3.6 Air Monitoring	12
3.7 <i>In Situ</i> Respiration Test	12
3.8 Air Permeability Test	14
3.9 Installation of Extended Pilot Test Bioventing System.....	14
4.0 Exceptions To Protocol Procedures	14
5.0 Base Support Requirements	14
5.1 Test Preparation.....	14
6.0 Project Schedule	15
7.0 Points of Contact	16
8.0 References.....	16

LIST OF FIGURES

Figure 2.1 Site Location Map..... 3

Figure 2.2 Site Plan 4

Figure 2.3 Typical Geologic Profile 6

Figure 3.1 Proposed Vent Wells and Vapor Monitoring
Points 8

Figure 3.2 Fire Training Area (FT-002) Injection Vent Well
Construction Detail 9

Figure 3.3 Fire Training Area (FT-002) Monitoring Point
Construction Detail 11

Figure 3.4 Schematic of Blower System for Air Injection..... 13

PART I

DRAFT BIOVENTING TEST WORK PLAN FOR

FIRE TRAINING PIT 1

AND

FIRE TRAINING PIT 4 AND OIL/WATER SEPARATOR

(FIRE TRAINING AREA - 002)

PLATTSBURGH AFB, NEW YORK

1.0 INTRODUCTION

This test work plan presents the scope of an *in situ* bioventing pilot test for treatment of fuel contaminated soils within Fire Training Area - 002 (FT-002) at Fire Training Pit (FTP) 1 and FTP 4 (including the oil/water separator) on Plattsburgh AFB, NY. The pilot test has three primary objectives: 1) to assess the potential for supplying oxygen throughout the contaminated soil depth, 2) to determine the rate at which indigenous microorganisms will degrade fuel when stimulated by oxygen rich soil gas, 3) to evaluate the potential for sustaining these rates of biodegradation until fuel contamination is remediated below regulatory standards.

Pilot testing will consist of two phases, and initial air permeability and *in situ* respiration test which will take place in May or June of 1993, and an extended one year pilot test which will be used to determine the potential for bioventing remediation using natural nutrient levels. Testing will also provide an estimate of cold weather biodegradation rates. The initial and extended pilot test will serve as treatability studies under the CERCLA feasibility study process. If bioventing proves to be feasible at this site, pilot test data may be used to design a full scale remediation system and to estimate the time required for site cleanup.

The initial test will involve injection at a vent well with a regenerative blower to produce a radius of influence of at least 60 feet. *In situ* rates of fuel biodegradation and soil gas permeability will be determined during this short term test and a decision on how best to proceed with extended testing will be made with regulatory concurrence.

Additional background information on the development and recent success of the bioventing technology is found in the document entitled *Test Plan and Technical Protocol For A Field Treatability Test For Bioventing* (Hinchee, et al. 1992). This protocol document is a supplement to the site-specific work plan, and it will also serve as the primary reference for pilot test vent well designs and detailed test objectives and

procedures. Unless otherwise noted, test procedures outlined in the protocol document will be used during the pilot tests at FTP 1 and FTP 4/ oil/water separator.

2.0 SITE DESCRIPTION

2.1 Fire Training Pit Area - 002

2.1.1 Site Location and History

Fire Training Area - 002 (FT-002) is located approximately 500 feet west of the runway, approximately 500 feet east of the Plattsburgh AFB boundary, south of landfill LF-022 and north of LF-023. The site is located on a land surface which slopes gently toward the Saranac and Salmon Rivers which are located approximately 1.9 miles east of the site (Figure 2.1). Four bermed pits are located at the site ranging from approximately 60 to 160 feet in diameter. The majority of the soil contamination on the site is beneath and adjacent to Pit 1, the smaller of these bermed pits. Figure 2.2 shows the location of the pits in relation to Perimeter Road.

Fire training exercises were conducted at this site from the middle to late 1950s and continued until the site was permanently closed on May 22, 1989. Typically, the bottom of the pit was saturated with water and then filled with a layer of jet fuel and then ignited. Fire fighters would practice extinguishing the flames which generally surrounded a mock metal aircraft in the pit. Unburned fuel soaked into the ground creating the contaminated soil column now found beneath the pit. In 1980, cement-stabilized soil liners were added to Pits 2 and 3 which were active at that time; Pits 1 and 4 had been deactivated. Prior to strict environmental regulations, solvents and other chemicals were sometimes mixed with the fuel and placed in the pit for burning. Some fuel and noncombustible fluids seeped into the soil beneath the unlined pits or leaked through cracks in the lined pits. After years of training activities at the site, the soil column beneath each pit has become contaminated with fuel-related compounds and solvents. Another potential source is the oil/water separator that received drainage from Pits 2 and 3. The hydrocarbon contamination from these sources is the target for bioventing treatment at this site.

2.1.2 Site Geology

Because the bioventing technology is applied to the unsaturated soils, this section will primarily address soils above the shallow aquifer. Soils at this site consist of Pleistocene marine deposits which results in uniform layers of sand and clay overlying till and carbonate bedrock. Ground water is encountered within the sand in the area of the pits at a depth of approximately 29 to 43 feet and generally flows southeasterly toward Salmon River.

Due to the homogeneous nature of the sand, the permeability of soils to air flow should remain relatively constant across the site. Effective bioventing on this site is likely. Engineering-Science has completed successful bioventing projects within similar geological deposits and we are confident that oxygen can be distributed in these soils. Initial testing has also been completed in adjacent Pits 2 and 3 and results have indicated excellent distribution of oxygen and biodegradation rates up

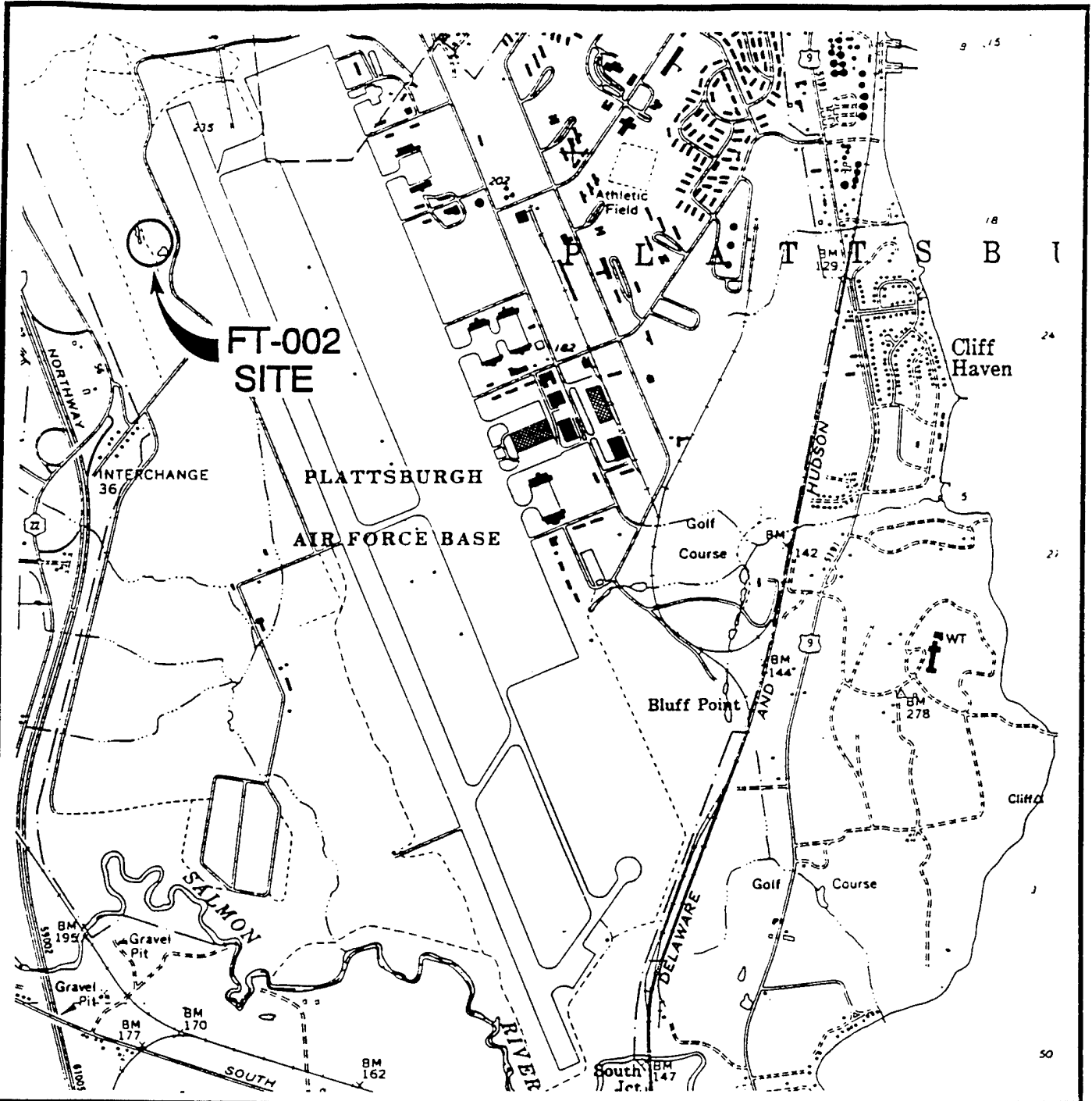

BASE MAP : U.S.G.S. 7.5 TOPOGRAPHIC MAP
(QUADRANGLE) PLATTSBURGH, NEW YORK

SCALE

0 2000 4000 FT.



ENGINEERING-SCIENCE

SITE LOCATION MAP

PLATTSBURGH AFB
Plattsburgh, New York

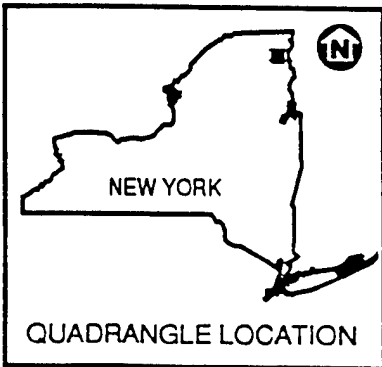

LATITUDE : 44° 37' 30" N
LONGITUDE : 73° 30' 00" W

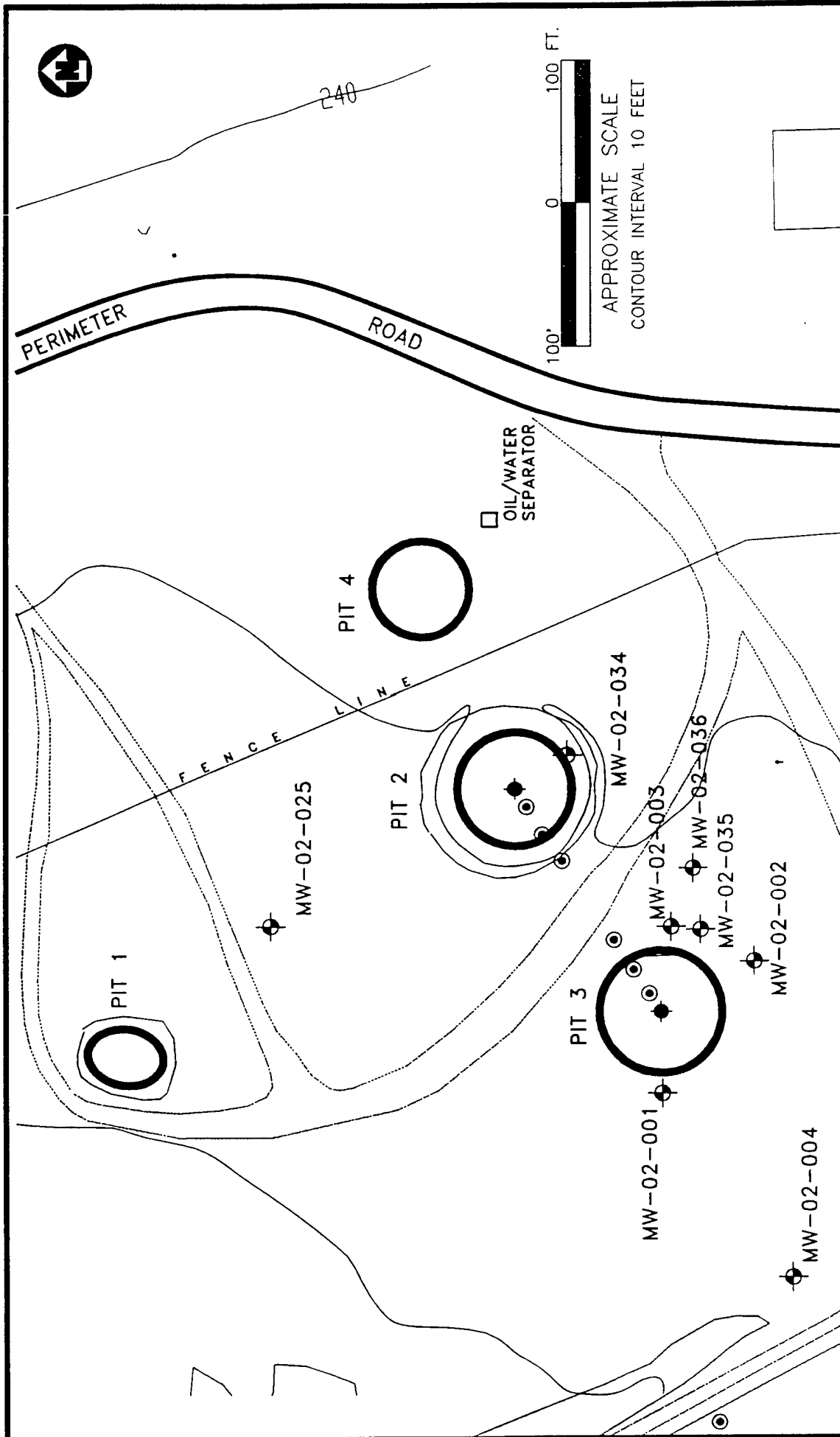

SITE PLAN

PLATTSBURGH AFB
Plattsburgh, New York

- LEGEND:**
- MW-02-002-⊕ EXISTING MONITORING WELL
 - ⊕ EXISTING VENT WELL
 - ⊙ EXISTING VAPOR MONITORING POINT (VMP)

to 5,400 mg total petroleum hydrocarbon (TPH) per kg soil per year. To monitor the bioventing test, soil vapor monitoring points will be positioned in three locations adjacent to the vent wells installed in Pits 1 and 4. Three depths at each point will be monitored to study the subsurface oxygen distribution and to measure *in situ* respiration rates.

2.1.3 Site Contaminants

Pit 1

The primary contaminants in the Pit 1 source area are fuel residuals which have migrated to a depth of approximately 43 feet where the maximum depth to groundwater is encountered. Figure 2.3 shows a typical cross-section across the center of the site (ABB Environmental Services, 1992). Free product has been observed in monitoring wells in the source area and on the site near Pit 1. A maximum petroleum hydrocarbon (PHC) concentration of 12,000 mg/kg has been detected in the surface soils sampled at a depth between 2 and 4 feet below ground surface (bgs). Samples collected inside the pit source area and above the water table showed PHC concentrations from 1,800 to 12,000 mg/kg. Volatile organic compounds benzene, toluene, ethylbenzene, and total xylenes (BTEX) were detected in the soils above the water table along with trace amounts of chlorinated solvents such as trichloroethene and dichloroethene compounds (ABB Environmental Services, 1992).

Pit 4 and Oil/Water Separator

The primary contaminants in the Pit 4 source area are fuel residuals which have migrated to a depth of approximately 35 feet where the maximum depth to groundwater is encountered. Figure 2.3 shows a typical cross-section across the center of the site (ABB Environmental Services, 1992). Free product has been observed in monitoring wells downgradient of Pit 4 near the oil/water separator. A maximum PHC concentration of 4,500 mg/kg has been detected in the surface soils sampled at a depth between 2 and 4 feet bgs. Samples collected inside the pit source area and above the water table showed PHC concentrations from 450 to 7,250 mg/kg. Trace amounts of volatile organic compounds ethylbenzene and xylenes were also detected in the soils above the water table. PHC concentrations in a boring next to the oil/water separator were below the detection limit except at the water table where they exceeded 20,000 mg/kg. (ABB Environmental Services, 1992).

3.0 PILOT TEST ACTIVITIES

3.1 Introduction

The purpose of this section is to describe the work that will be performed by Engineering-Science, Inc. (ES) at FTPs 1 and 4. Activities that will be performed at each site include siting and construction of a central vent well (VW) and three vapor monitoring points (VMPs); an *in situ* respiration test; an air permeability test; and the installation of an extended bioventing pilot test system. Soil and soil gas sampling procedures and blower configuration that will be used to inject air

TYPICAL
GEOLOGIC PROFILE
PLATTSBURGH AFB
Plattsburgh, New York

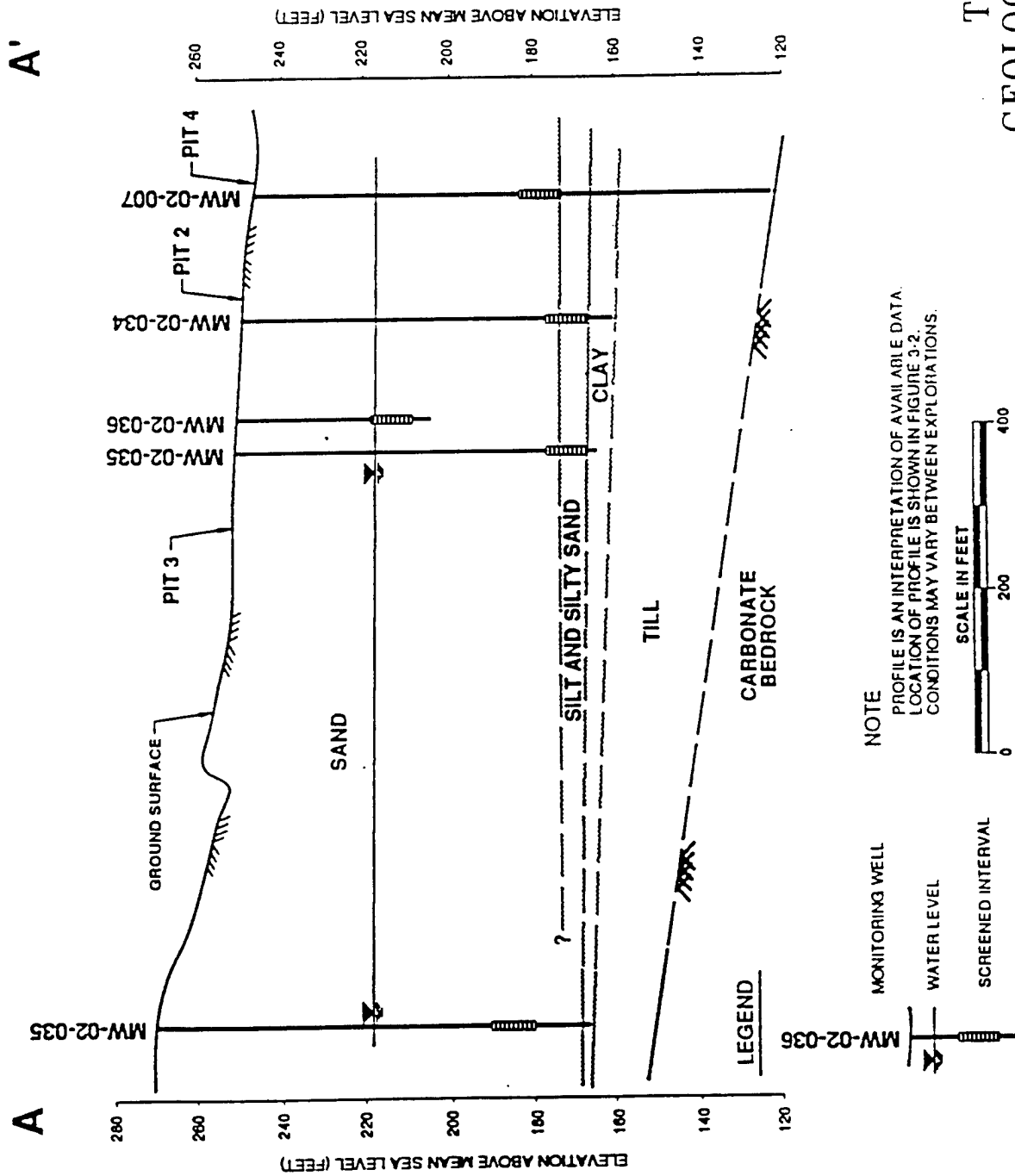

NOTE
PROFILE IS AN INTERPRETATION OF AVAILABLE DATA.
LOCATION OF PROFILE IS SHOWN IN FIGURE 3-2.
CONDITIONS MAY VARY BETWEEN EXPLORATIONS.



LEGEND
MONITORING WELL
WATER LEVEL
SCREENED INTERVAL

(FROM ABB ENVIRONMENTAL SERVICES, INC., 1992)

(oxygen) into contaminated soils are also discussed in this section. In an effort to be as cost effective as possible, a single VW will be completed to the depth of lowest seasonal groundwater at each site. Pilot test activities will be confined to unsaturated soils remediation; no dewatering will take place during the pilot tests. Existing monitoring wells will not be used as primary air injection or extraction wells. However, monitoring wells which have a portion of their screened interval above the water table may be used as VMPs or to measure the composition of background soil gas. Existing VMPs in FTP 2 may also be monitored during air permeability testing associated with the Pit 4 area.

3.2 Well Siting and Construction

3.2.1. Well Siting and Construction for Pit 1

A general description of criteria for siting a single central VW and associated VMPs in the pit are included in the attached protocol document. Figure 3.1 illustrates the proposed location of the central VW and VMPs at the pit. The final location of the VW may vary slightly from the proposed location if significant fuel contamination is not observed in the boring for the central VW. Based on site investigation data, the VW will be located just off the center of the bermed fire training pit. The area is expected to have an average TPH concentration exceeding 5,000 mg/kg. Soils in this area are expected to be oxygen depleted (< 2%) and increased biological activity should be stimulated by oxygen-rich soil gas ventilation during full-scale operations.

Due to the relatively deep depth of contamination at this site and the potential for moderate permeability soils, the radius of venting influence around the central air injection well in the pit is expected to exceed 60 feet. Three VMPs will be located within a 60-foot radius of the central VW. Background monitoring for this test will be conducted at the background vapor monitoring point located approximately 600 feet west of Pit 4. The background well will be used to measure background levels of oxygen and carbon dioxide and to determine if natural carbon sources are contributing to oxygen uptake during the *in situ* respiration test.

The VW will be constructed of 4-inch ID Schedule 40 PVC, with a 35 foot interval of 0.04 slotted screen set between 10 and 45 feet bgs (the deepest seasonal groundwater elevation). Flush-threaded PVC casing and screen will be used with no organic solvents or glues. The filter pack will be clean, well-rounded silica sand with a 6-9 grain size and will be placed in the annular space of the screened interval. A 7-foot layer of bentonite will be placed directly over the filter pack. The first foot of bentonite will consist of granular bentonite and/or pellets hydrated in place with potable water. This layer of granular or pellets will prevent the addition of bentonite slurry from saturating the filter pack. The remaining 6 feet of bentonite will be fully hydrated and mixed above ground and the slurry tremied into the annular space to produce an air tight seal above the screened interval. A complete seal is critical to prevent injected air from short-circuiting to the surface during the bioventing test. Silica sand and cement grout will placed over the slurry and extend to the ground surface. Figure 3.2 illustrates the proposed central VW construction details for this site.

**PROPOSED
VENT WELLS AND
VAPOR MONITORING POINTS
PLATTSBURGH AFB
Plattsburgh, New York**

- LEGEND:**
- MW-02-002-⊕ EXISTING MONITORING WELL
 - ⊕ EXISTING VENT WELL
 - ⊙ EXISTING VAPOR MONITORING POINT (VMP)
 - PROPOSED VAPOR MONITORING POINT (VMP)
 - ⊕ PROPOSED VENT WELL

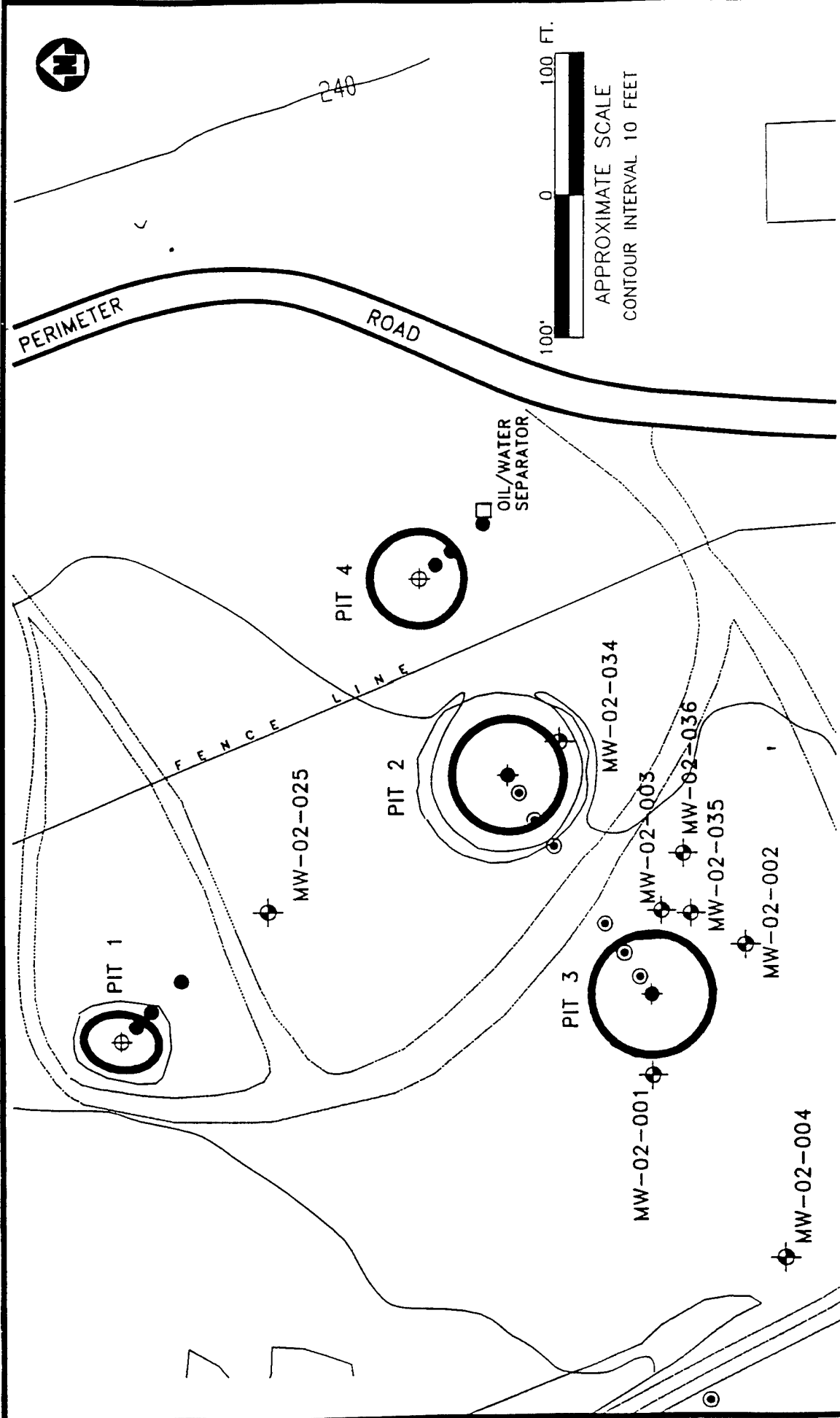

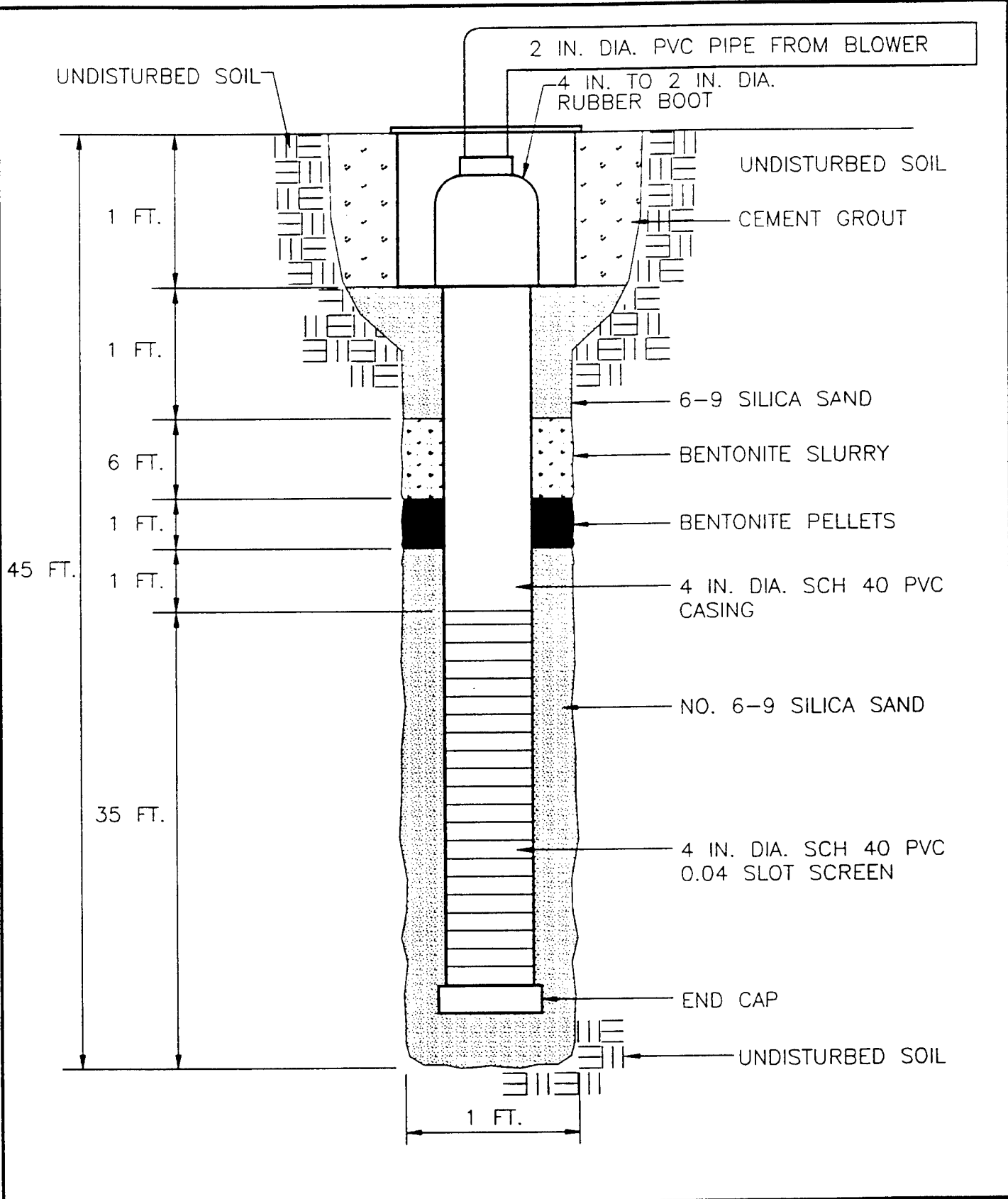

NOT TO SCALE

FIRE TRAINING AREA
(FT - 002)
INJECTION VENT WELL
CONSTRUCTION DETAIL
PLATTSBURGH AFB, NEW YORK

ENGINEERING-SCIENCE, INC.
Syracuse, New York



A typical multi-depth VMP installation for this site is shown in Figure 3.3. Soil gas oxygen and carbon dioxide concentrations will be monitored at depth intervals of approximately 10 - 12 feet, 25 - 27 and 40 - 42 feet at each location (the deepest monitoring point will be set at approximately 3 feet above the deepest seasonal groundwater elevation). Multi-depth monitoring will confirm that the entire soil profile is receiving oxygen and be used to measure fuel biodegradation rates at all depths. The annular space between these three monitoring points will be sealed with bentonite to isolate the monitoring intervals. As with the central vent well, several inches of granular bentonite or pellets will be used to shield the filter pack from rapid infiltration of bentonite slurry additions. Additional details on VW and monitoring point construction are found in Section 4 of the protocol document.

3.2.2 Well Siting and Construction for Pit 4

The methods used for well siting and construction for Pit 4 will be identical to those used for Pit 1 with a few exceptions. The vent well will be screened from 10 to 35 feet bgs, and the monitoring point depth intervals will be approximately 8 - 10 feet, 19 - 21 feet, and 30 - 32 feet.

3.3 Handling of Drill Cuttings

Drill cuttings from all borings will be left at each location in accordance with the current procedures for ongoing remedial investigations.

3.4 Soil and Soil Gas Sampling

3.4.1 Soil Sampling

Three soil samples will be collected from each pilot test area during the installation of the VWs and VMPs. One sample will be collected from the most contaminated interval of the central VW boring and one sample will be collected from the interval of highest apparent contamination in each of the borings for two VMPs at each site. Soil samples will be analyzed for TPH, BTEX, soil moisture, pH, particle sizing, alkalinity, total iron and nutrients.

Samples will be collected using a split- spoon sampler containing brass tube liners. A photoionization detector or total hydrocarbon vapor analyzer (see protocol Section 4.5.2) will be used to insure that breathing zone levels of volatiles do not exceed 1 ppm during drilling and to screen split spoon samples for intervals of high fuel contamination. Soil samples collected in the brass tubes will be immediately trimmed and aluminum foil and a plastic cap placed over the ends. Soil samples will be labelled following the nomenclature specified in the protocol document(Section 5.5), wrapped in plastic, and placed in an ice chest for shipment. A chain of custody form will be filled out and the ice chest shipped to the ES laboratory in Berkeley, California, for analysis. This laboratory has been audited by the U.S. Air Force and meets all quality assurance/quality control and certification requirements for the State of California.

3.4.2 Soil Gas Sampling

A total of six soil gas samples will be collected in SUMMA™ canisters in accordance with the *Bioventing Field Sampling Plan* (ES, 1992). The samples will be

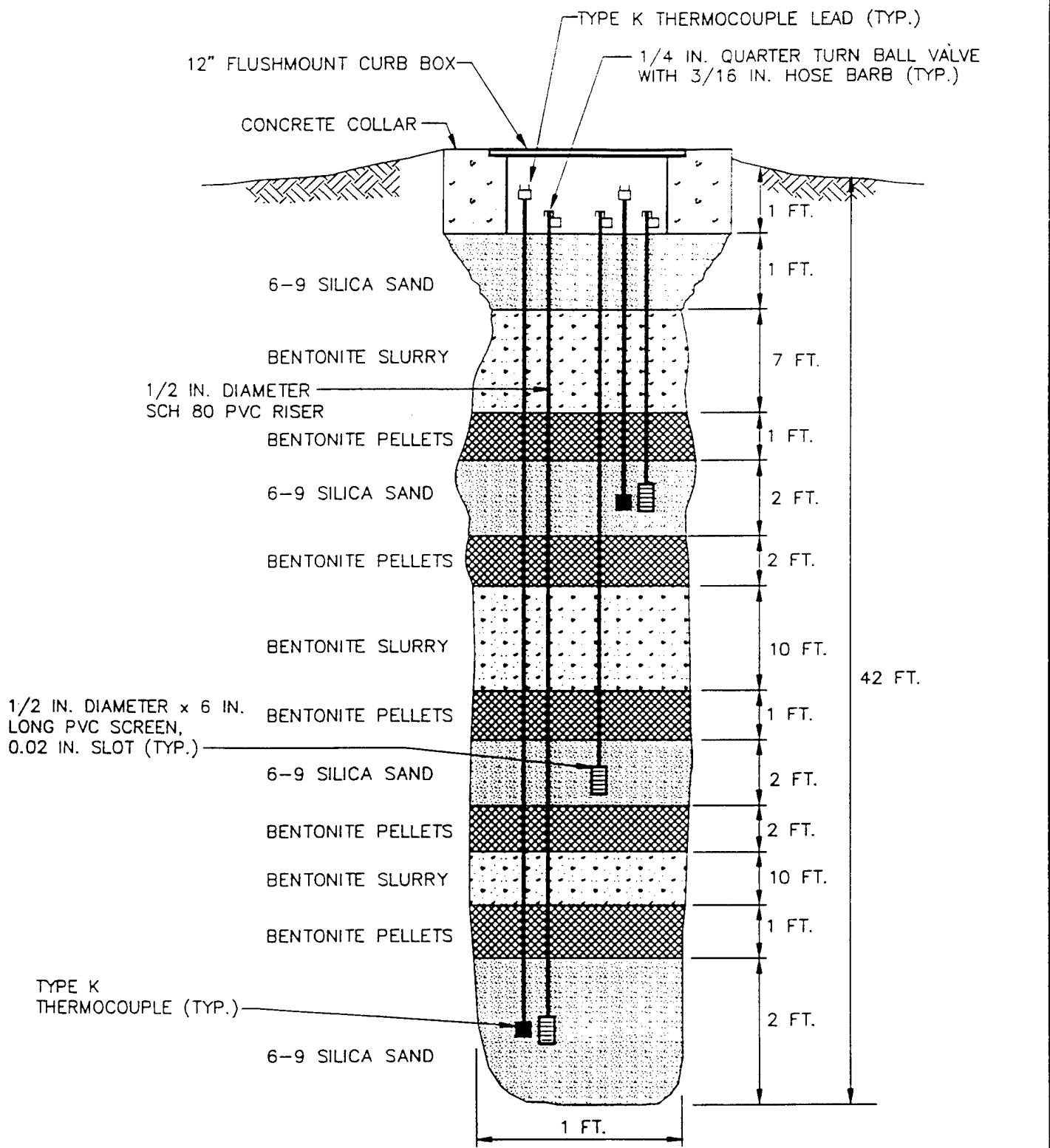

NOT TO SCALE

FIRE TRAINING AREA
 (FT - 002)
 TYPICAL MONITORING POINT
 CONSTRUCTION DETAIL
 PLATTSBURGH AFB, NEW YORK

ENGINEERING-SCIENCE, INC.
 Syracuse, New York

ES

collected from the VW in Pit 1, from the VW in Pit 4, and from the VMPs closest to and furthest from the VW at each site. These soil gas samples will be used to predict potential air emissions, to determine the reduction in BTEX and total volatile hydrocarbons (TVH) during the 1-year test, and to detect any migration of these vapors from the source area.

Soil gas sample canisters will be placed in a small cooler and packed with foam pellets to prevent excessive movement during shipment. Samples will not be sent on ice to prevent condensation of hydrocarbons. A chain-of-custody form will be filled out, and the cooler will be shipped to the Air Toxics laboratory in Rancho Cordova, California for analysis.

3.5 Blower System

A 2.5-HP blower capable of injecting 30 - 90 scfm will be used to conduct the initial air permeability test at the two sites. This blower provides a wide range of flow rates and should develop sufficient pressure to move air through moderate permeability soils. Air injection will be used to provide oxygen to soil bacteria and to minimize emissions of volatiles to the atmosphere. If initial testing at either site indicates that less pressure is required to supply oxygen throughout the test volume, a smaller blower will be installed for extended testing.

An extended pilot test will be performed if initial pilot testing is positive. The extended bioventing test will be initiated following a review of initial test data and regulatory approval. Figure 3.4 is a schematic of a typical air injection system that will be used for pilot testing at these sites.

The maximum power requirement anticipated for this pilot test is a 230-volt, single-phase, 30-amp service. Additional details on power supply requirements are described in Section 5.0, Base Support Requirements.

3.6 Air Monitoring

The bioventing technique will minimize the loss of volatiles to the atmosphere by reducing air injection rates to the minimum required for oxygen supply for biodegradation. During air injection, the air will be monitored for volatile hydrocarbons at the soil surface and in the breathing zone to account for any volatilization that does occur and to ensure safe working conditions.

3.7 In Situ Respiration Test

The objective of the *in situ* respiration test is to determine the rate at which soil bacteria degrade petroleum hydrocarbons. Respiration tests will be performed at the three VMPs with the highest apparent fuel contamination at each site. Air will be injected into each VMP depth interval containing low levels (<2%) of oxygen. A 20 to 24-hour air injection period will be used to oxygenate local contaminated soil. At the end of the air injection period, the air supply will be cut off, and oxygen and carbon dioxide levels will be monitored for five days or until the oxygen level falls below 5 %, whichever is earlier. The decline in oxygen and increase in carbon dioxide concentrations over time will be used to estimate rates of bacterial degradation of fuel residuals. Helium will also be injected at all three points at each

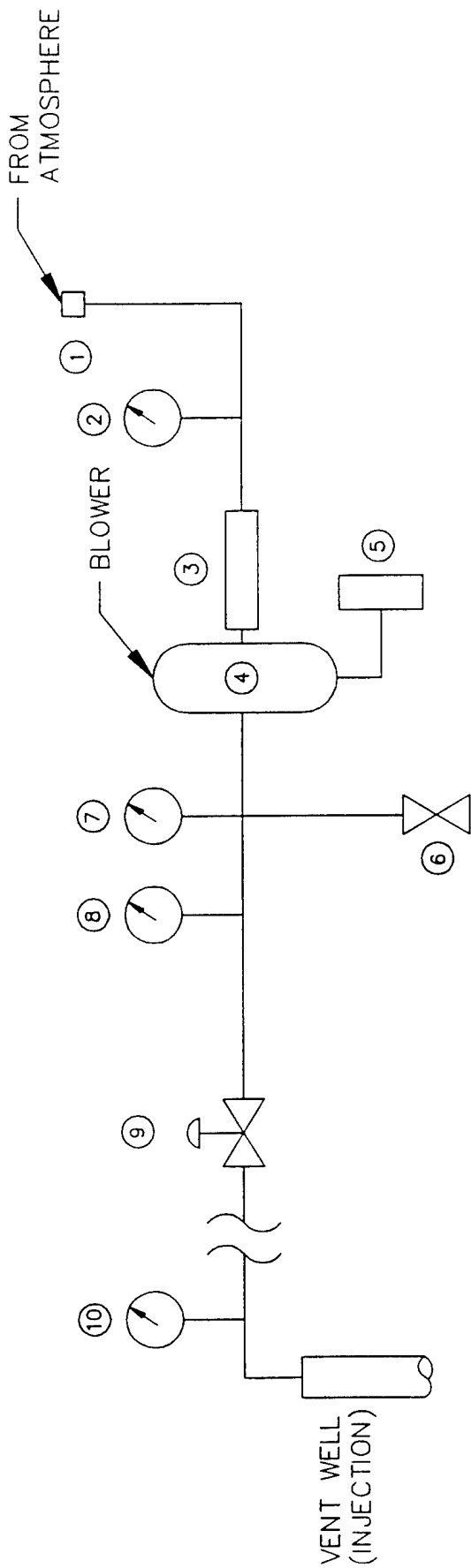

- ① INLET FILTER
- ② VACUUM GAUGE - INCHES OF H2O
- ③ DRIVE MOTOR
2.5 HP / 3450 RPM @ 60 Hz / 230 v / SINGLE PHASE / 15 A /
- ④ BLOWER - GAST R5125
145 SCFM @ 3450 RPM / REGENERATIVE
- ⑤ STARTER
230 v / 27 A / SINGLE PHASE / H1036 HEATER (10.8 A)
- ⑥ AUTOMATIC PRESSURE RELIEF VALVE - SET @ 6 psig
- ⑦ PRESSURE GAUGE (INCHES OF H2O)
- ⑧ THERMOMETER (FAHRENHEIT)
- ⑨ MANUAL PRESSURE RELIEF (BLEED) VALVE - 1 1/2" BALL
- ⑩ AIR VELOCITY MEASUREMENT PORT

SCHEMATIC OF BLOWER
SYSTEM FOR AIR INJECTION
FIRE TRAINING AREA (FT-002)

Plattsburgh AFB, New York

ENGINEERING-SCIENCE, INC.
Syracuse, New York



site to ensure that the VMPs do not leak and to estimate oxygen diffusion rates in site soils. Additional details on the *in situ* respiration test are found in Section 5.7 of the protocol document.

3.8 Air Permeability Test

The objective of the air permeability test is to determine the extent of the subsurface that can be oxygenated using one air injection VW. Air will be injected into the 4-inch-diameter VW using the blower unit, and pressure response will be measured at each VMP with differential pressure gauges to determine the region influenced by the unit. Oxygen will also be monitored in the VMPs to verify that oxygen levels in the soil increase as the result of air injection. One air permeability test lasting 4 to 8 hours will be performed.

3.9 Installation of Extended Pilot Test Bioventing System

Extended, 1-year bioventing pilot systems will also be installed at Pits 1 and 4. The base will be requested to provide a power pole with a 230-volt, single-phase, 30-amp breaker box. Two 115-volt receptacles will also be required. Depending on the availability of a base electrician, a base electrician or a licensed electrician subcontracted to ES will assist in wiring the blowers to line power. The blower will be housed in a small, prefabricated shed to provide protection from the weather.

The system will be in operation for 1 year, and at 6 months and 12-months of operation, ES personnel will conduct *in situ* respiration tests to monitor the long-term performance of this bioventing system. Weekly system checks will be performed by Plattsburgh AFB personnel. If required, major maintenance of the blower unit may be performed by ES personnel. Detailed blower system information and a maintenance schedule will be included in the operation and maintenance (O&M) manual provided to the base. More detailed information regarding the test procedures can be found in the protocol document.

4.0 EXCEPTIONS TO PROTOCOL PROCEDURES

The procedures that will be used to measure the air permeability of the soil and *in situ* respiration rates are described in Sections 4 and 5 of the protocol document. No exceptions to this protocol are anticipated.

5.0 BASE SUPPORT REQUIREMENTS

5.1 Test Preparation

The following base support is needed prior to the arrival of a driller and the ES test team:

- Confirmation of regulatory approval for the pilot test.
- Assistance in obtaining a digging permit at each site.
- A breaker box or generator within 50 feet of the proposed VW which can supply 230-volt, single-phase, 30-amp service for the initial and extended pilot test. This service will be supplied from a central breaker box situated in the area of the fire training pits.

- Provision of any paperwork required to obtain gate passes and security badges for approximately four ES employees and two drillers. Vehicle passes will be needed for two trucks and a drill rig.

During the initial three week pilot test the following base support is needed:

- Twelve square feet of desk space and a telephone in a building located as near to the site as practical.
- The use of a fax machine for transmitting 15 to 20 pages of test results.

During the one year extended pilot test the following base support is needed:

- Check the blower system at FT-002 at least once a week to ensure that it is operating and to record the air injection pressure. Engineering-Science will provide a brief training session on this procedure.
- Notify Mr. Richard Moravec or Mr. David Brown, ES-Syracuse, (315) 451-9560; or Mr. Jerry Hansen of the AFCEE, (210) 536-5343, if the blower or motor stop working.
- Arrange site access for an ES technician to conduct *in situ* respiration tests approximately six months and one year after the initial pilot test.

6.0 PROJECT SCHEDULE

The following schedule is contingent upon timely approval of this pilot test work plan.

Event	Date
Draft Test Work Plan to AFCEE	Feb 1993
Submit Test Plan for Regulatory Approval	23 April 1993
Regulatory Approval To Proceed	10 May 1993
Begin Pilot Test	1 June 1993
Complete Initial Pilot Test	18 June 1993
Interim Results Report	30 July 1993
Six Month Respiration Test	Dec 1993
Final Respiration Test	June 1994

7.0 POINTS OF CONTACT

Mr Brady Baker
380 SPTG/CEV
Plattsburgh AFB, New York 12903-3316
(518) 565-6672 DSN 689-6672

Major Ross Miller/Mr. Jerry Hansen
AFCEE/ESR/ESCT
Brooks AFB, Texas 78235-5000
(210) 536-4331/(210) 536-5343

Mr. Richard Moravec/Mr. Dave Brown
Engineering-Science, Inc
290 Elwood Davis Road, Suite 312
Liverpool, New York 13088
(315) 451-9560 Fax.(315) 451-9570

8.0 REFERENCES

ABB Environmental Services, Inc. 1992. *FT-002 Soil Remedial Investigation Report, Draft Final, Plattsburgh Air Force Base.* Plattsburgh, New York. April.

Engineering-Science, Inc. 1992. *Project Management Plan for AFCEE Bioventing, Appendix D, Field Sampling Plan.* Denver, Colorado. April.

Hinchee, R.E., S.K. Ong, R.N. Miller, D.C. Downey, R. Frandt. 1992. *Test Plan and Technical Protocol for a Field Treatability Test for Bioventing.* Columbus, Ohio. January.

PART II
DRAFT INTERIM PILOT TEST RESULTS REPORT FOR
FIRE TRAINING PIT 4
(FT-002)
PLATTSBURGH AFB, NEW YORK

Prepared for

Air Force Center for Environmental Excellence
Brooks AFB, Texas

and

380th Civil Engineering Squadron and
Environmental Management Branch
Plattsburgh AFB, New York

by

Engineering-Science, Inc
290 Elwood Davis Road
Liverpool, New York

August 1994

TABLE OF CONTENTS

1.0 FIRE TRAINING PIT 4	1
1.1 Pilot Test Design and Construction	1
1.2 Vent Well Construction	1
1.3 Soil Vapor Monitoring Points.....	1
1.4 Blower Unit Installation.....	5
2.0 PILOT TEST SOIL AND SOIL GAS SAMPLING RESULTS	5
2.1 Soil and Soil Gas Sampling Results	5
2.2 Exceptions to Test Protocol Document Procedures	8
2.3 Field QA/QC Results.....	8
3.0 PILOT TEST RESULTS	8
3.1 Initial Soil Gas Chemistry	8
3.2 Air Permeability	11
3.3 Oxygen Influence	11
3.4 In-Situ Respiration Rates	11
3.5 Potential Air Emissions	18
4.0 RECOMMENDATIONS	18
5.0 REFERENCES	19

LIST OF FIGURES

Figure 1.1 2
Figure 1.2 3
Figure 1.3 4
Figure 1.4 6
Figure 1.5 7
Figure 3.1 14
Figure 3.2 15
Figure 3.3 16

LIST OF TABLES

Table 2.1 9
Table 3.1 10
Table 3.2 12
Table 3.3 13
Table 3.4 17

PART II

DRAFT INTERIM TEST RESULTS REPORTS FOR

FIRE TRAINING PIT 4

(FT-002)

PLATTSBURGH AFB, NEW YORK

An initial bioventing pilot test was performed at Fire Training Area 002 Pit 4 (Pit 4) at Plattsburgh Air Force Base (AFB), New York during the period of 29 March 1994 to 5 April 1994. The purpose of this Part II Report is to describe the results of the initial pilot tests and to make specific recommendations for extended testing to determine the long-term impact of bioventing to remediate site contaminants. Descriptions of the history, geology, and site contaminants are contained in Part I, the Pilot Test Work Plan.

1.0 FIRE TRAINING PIT 4

1.1 Pilot Test Design and Construction

In accordance with the Test Work Plan, one vertical air injection vent well (VW) and three multiple-depth soil vapor monitoring points (MPs) were installed the week of 21 March 1994. A 2.5-horsepower regenerative blower was installed at the VW to provide the necessary air for bioventing. Figure 1.1 depicts the locations of the VW, MPs and blower at the Pit 4 site. Figure 1.2 depicts the vertical hydrogeologic cross section around Pit 4. The following sections describe in more detail the final design and installation of the bioventing system.

1.2 Vent Well Construction

The VW was installed on 22 March 1994 in an area of documented high TPH contamination. The VW was constructed of 4-inch diameter Schedule 40 PVC with a slot size of 0.04 inches. The total depth of the VW was 36 feet below ground surface (bgs), with a screened interval from 6 to 36 feet bgs. The annular space between the well casing and the borehole was filled with 6-9 silica sand from the bottom of the boring to approximately five feet bgs. Granular bentonite was placed above the sand pack from five feet bgs to two feet bgs and hydrated in place with potable water. A one foot thick layer of 6-9 silica sand was placed above the bentonite seal to provide for drainage away from the protective well cover. The VW was finished with a 12-inch flushmount protective well cover which was cemented in place with a cement/bentonite grout. A detail of the VW construction is presented on Figure 1.3.

1.3 Soil Vapor Monitoring Points

Three soil vapor monitoring points (MPs) were installed at 15, 30 and 60 feet radially away from the air injection vent well. Each MP was constructed to provide

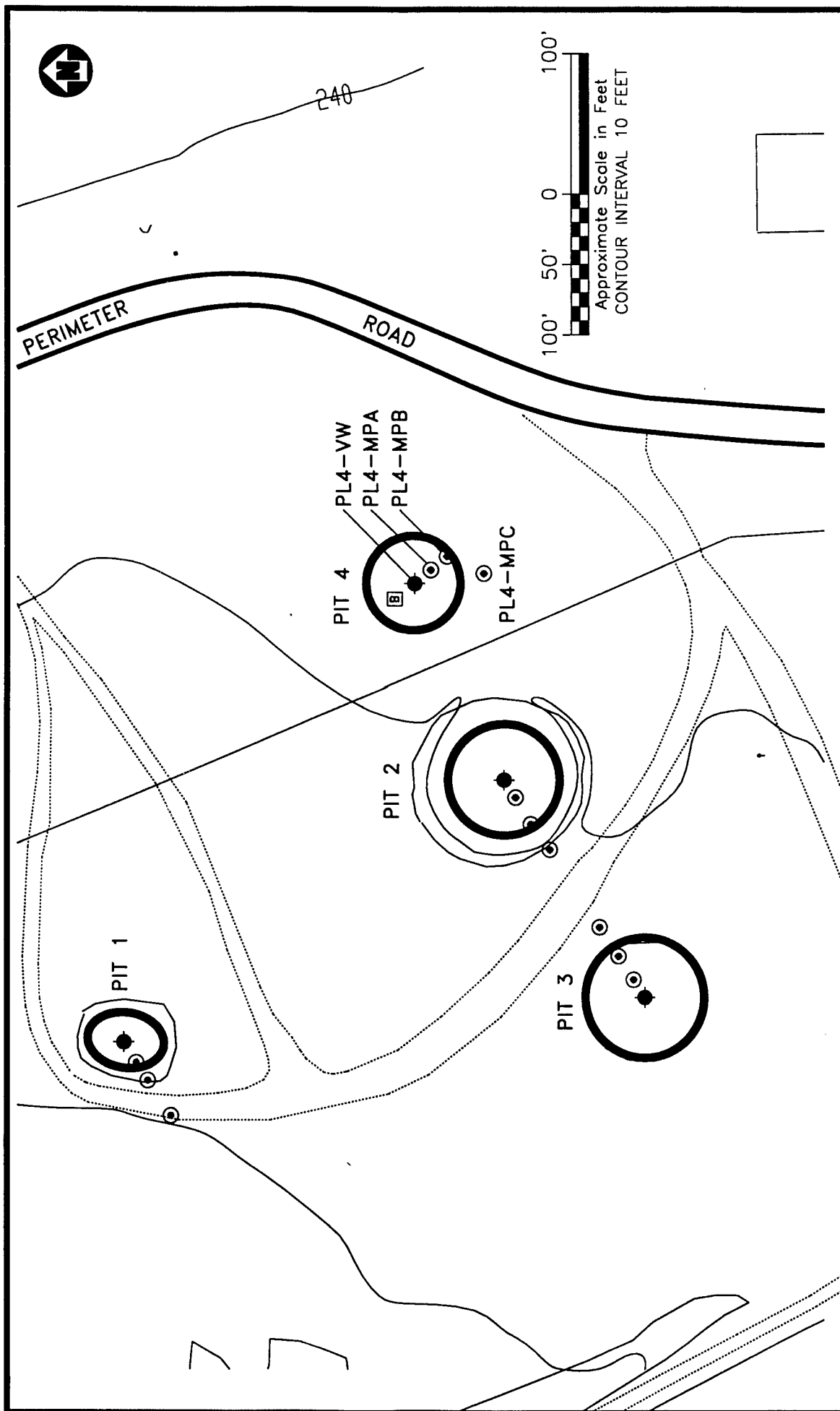

**VENT WELLS AND VAPOR
MONITORING POINTS**
 PLATTSBURGH AFB
 Plattsburgh, New York

- LEGEND:**
- EXISTING VENT WELL
 - EXISTING VAPOR MONITORING POINT (MP)
 - ◻ BLOWER UNIT

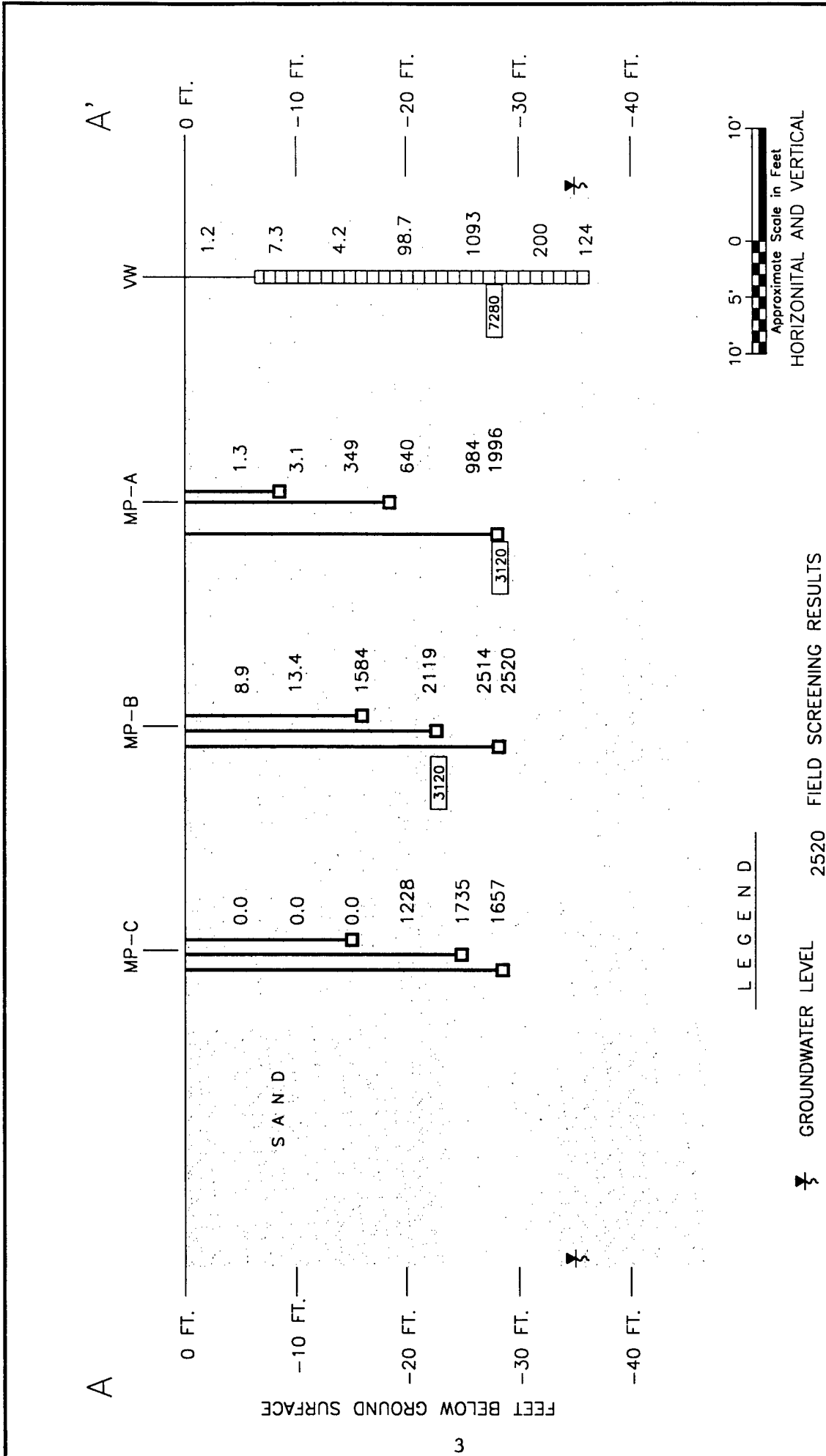

GEOLOGIC PROFILE
BIOVENTING SITE
FIRE TRAINING PIT 4

PLATTSBURGH AFB, NEW YORK
 ENGINEERING-SCIENCE, INC.
 Syracuse, New York

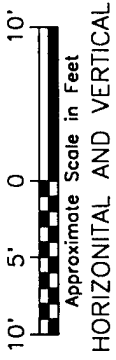

LEGEND

- GROUNDWATER LEVEL
- MONITORING POINT
- AIR INJECTION WELL
- SCREEN INTERVAL
- 2520 FIELD SCREENING RESULTS FOR TOTAL VOLATILE HYDROCARBONS (ppmv)
- 7280 LABORATORY RESULTS FOR SOIL TOTAL PETROLEUM HYDROCARBONS (PPM)
- VW VENT WELL
- MP-A MONITORING POINT

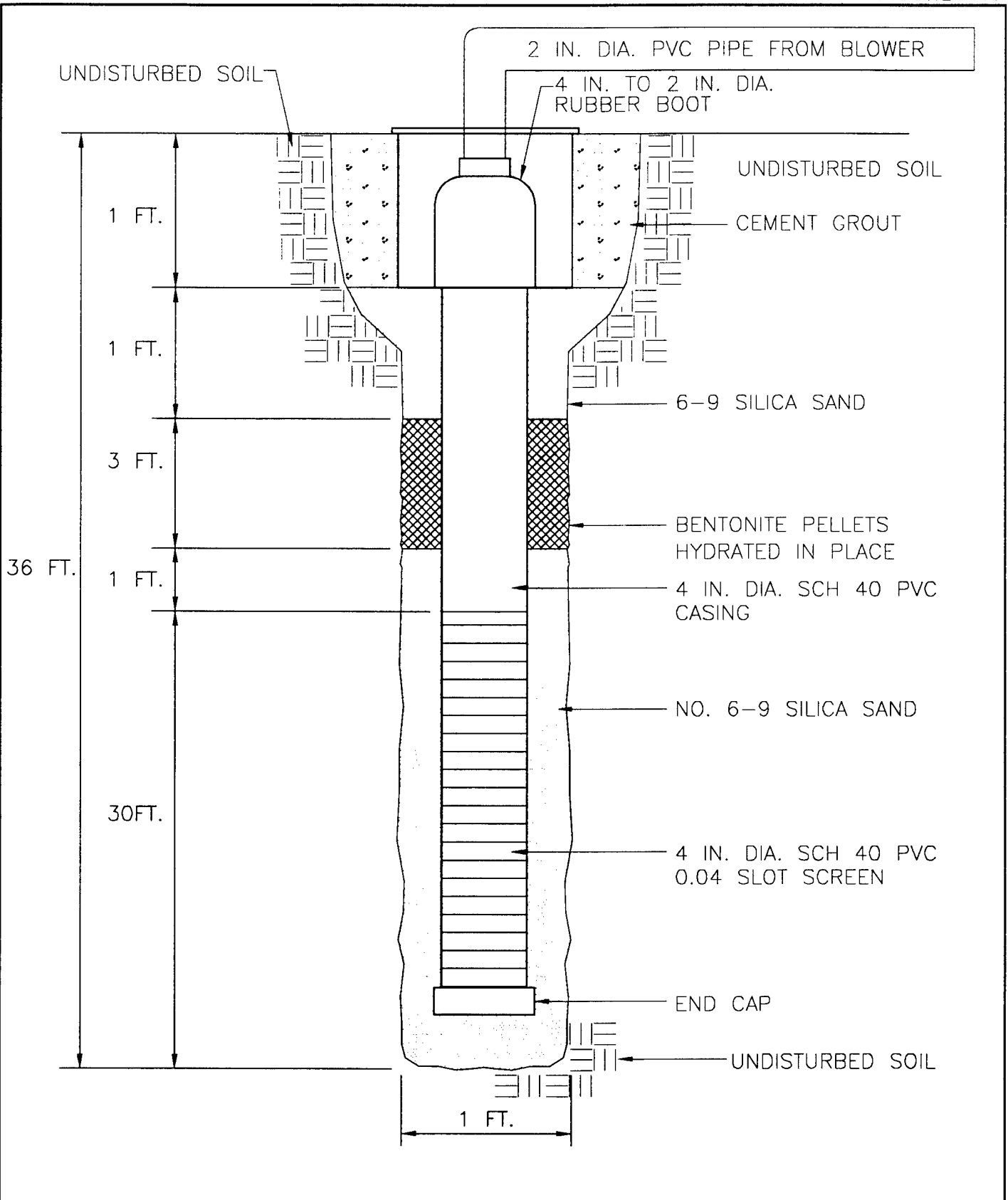

NOT TO SCALE

INJECTION VENT WELL
CONSTRUCTION DETAIL

PLATTSBURGH AFB, NEW YORK

ENGINEERING-SCIENCE, INC.
Syracuse, New York

multiple depth soil gas monitoring with three discrete sample points. At the MP closest to the VW (MPA), the discrete depth monitoring intervals were placed at 10, 19, and 28 feet bgs. Because the depth to contaminated soil appeared to be deeper at the remaining two vapor monitoring points, MPB and MPC, the discrete depth monitoring intervals were placed at 16, 22, and 28 feet bgs. Each discrete point was constructed of a six-inch long piece of 1/2-inch diameter Schedule 40 PVC well screen with 0.02 slot size. The riser of each discrete point was constructed of 1/2-inch Schedule 80 PVC, which extended to approximately six inches bgs.

Clean 6-9 silica sand was placed around each discrete point to provide a filter pack between the borehole wall and the point. Granular bentonite was placed both below and above each discrete point to provide an air tight seal between the points. The bentonite was placed in 12-inch lifts and hydrated in place to assure the proper seal. The top of each discrete point riser was fitted with a 1/4-inch quarter turn ball valve and 3/16-inch hose barb to allow for connection of appropriate monitoring instruments.

Additionally, Type K thermocouples with mini connectors were installed at the 28 feet and 10 feet bgs discrete monitoring points at MPA. These thermocouples will be used to measure the temperature profile at the site. The top of each MP was completed with a 12-inch flush mounted protective well cover set in a concrete base. Figure 1.4 shows the construction of the soil vapor monitoring points.

1.4 Blower Unit Installation

A 2.5-horsepower GAST® regenerative blower unit was installed at Pit 4 for the initial and extended pilot tests. The blower was installed in a weather resistant enclosure. Electric service for the blower was provided by a portable generator. Permanent electric service will be installed prior to initiation of the extended pilot test. Air from the blower is injected into the vent well via a two inch PVC line connected to the blower's exhaust port. A diagram of the blower unit and installation is presented on Figure 1.5.

Prior to departing the site, the ES engineer provided an operations and maintenance briefing, O&M checklist, and blower maintenance manual to the base point of contact. A copy of the O&M manual and checklist is provided in Appendix A.

2.0 PILOT TEST SOIL AND SOIL GAS SAMPLING RESULTS

2.1 Soil and Soil Gas Sampling Results

Soils at the Pit 4 site consist of fine to medium grained brown sands. This soil profile was consistent throughout the unsaturated zone and to approximately five feet below the groundwater surface which was encountered at approximately 35 feet bgs.

Hydrocarbon contamination at the site appears to extend from approximately 12 feet bgs to the groundwater table. Contaminated soils collected by split spoons during the VW and MP installations were identified based on visual appearance, odor and photoionization detector (PID) screening. Varying degrees of hydrocarbon staining were encountered throughout the vertical profile in the unsaturated soil zone, and light to strong hydrocarbon odors were noticed in nearly all the split spoon samples. PID

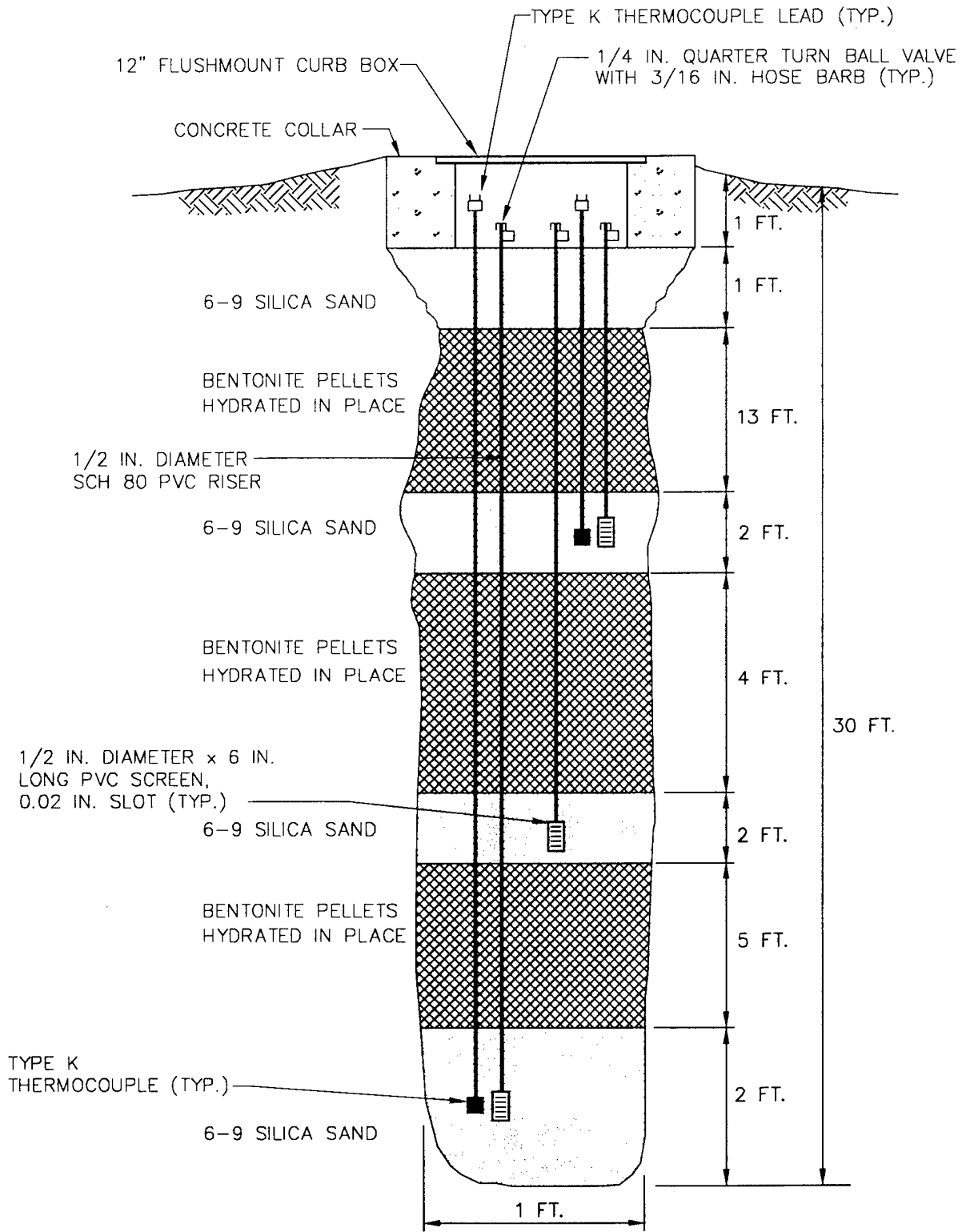

NOT TO SCALE

FIRE TRAINING PIT 4
TYPICAL MONITORING POINT
CONSTRUCTION DETAIL

PLATTSBURGH AFB, NEW YORK

ENGINEERING-SCIENCE, INC.
Syracuse, New York



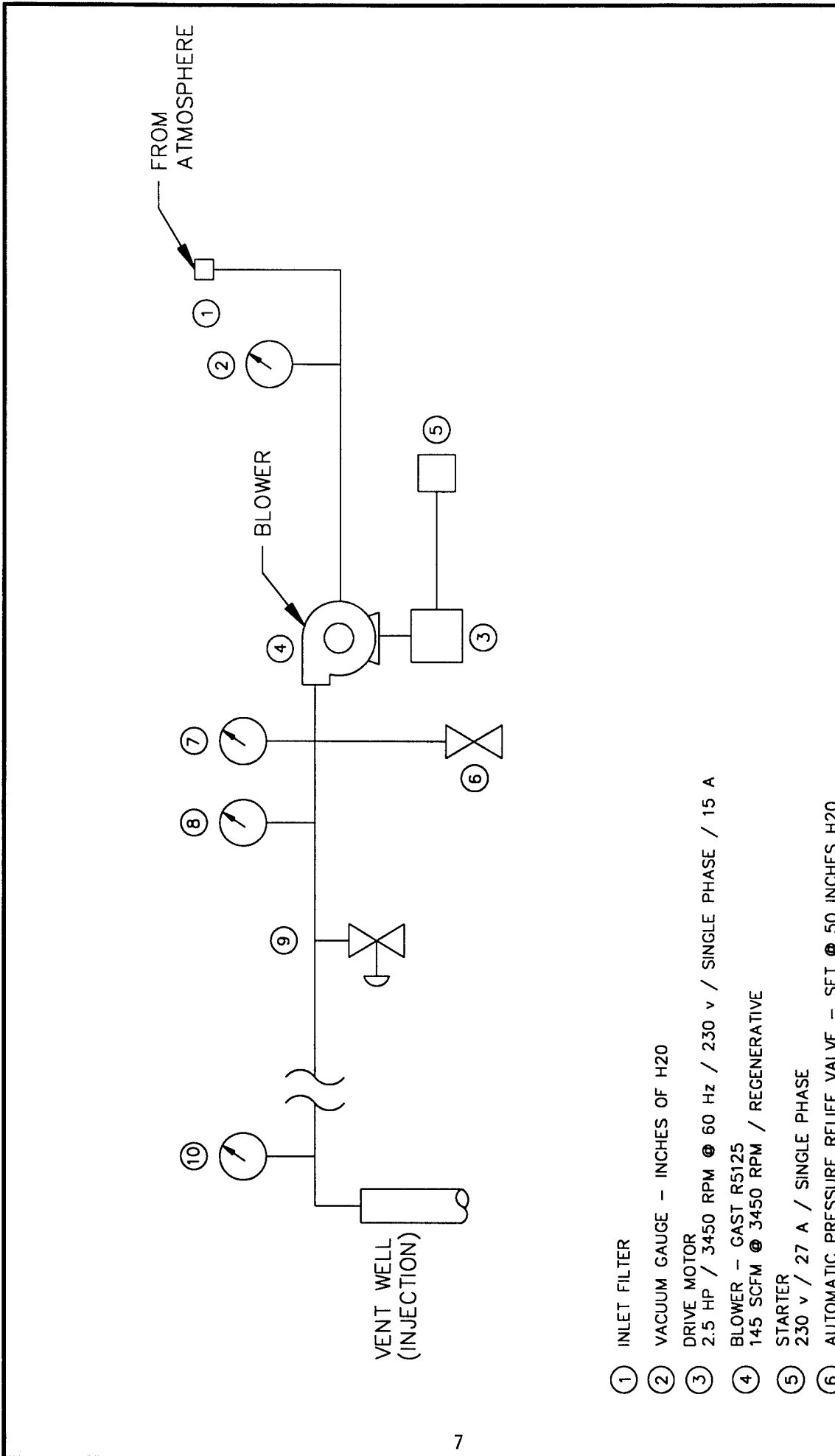

**SCHEMATIC OF BLOWER
SYSTEM FOR AIR INJECTION**

FIRE TRAINING PIT 4
PLATTSBURGH AFB, NEW YORK

ENGINEERING-SCIENCE, INC.
Syracuse, New York



- ① INLET FILTER
- ② VACUUM GAUGE - INCHES OF H2O
- ③ DRIVE MOTOR
2.5 HP / 3450 RPM @ 60 Hz / 230 v / SINGLE PHASE / 15 A
- ④ BLOWER - GAST R5125
145 SCFM @ 3450 RPM / REGENERATIVE
- ⑤ STARTER
230 v / 27 A / SINGLE PHASE
- ⑥ AUTOMATIC PRESSURE RELIEF VALVE - SET @ 50 INCHES H2O
- ⑦ PRESSURE GAUGE (INCHES OF H2O)
- ⑧ THERMOMETER (FAHRENHEIT)
- ⑨ MANUAL PRESSURE RELIEF (BLEED) VALVE - 1 1/2" BALL
- ⑩ AIR VELOCITY MEASUREMENT PORT

readings of greater than 1,000 parts per million (ppm) were measured in a number of soil samples.

Soil samples for laboratory analysis were collected in stainless steel split spoons during the VW and MP installations. Procedures for soil sample collection specified in the Protocol Document (Hinchee, et. al., 1992) were followed for all sample collections. Samples were collected from the 26-28 feet interval from the VW, from the 27-29 feet interval in MPA, and from the 21-23 feet interval in MPB. All split spoon samples were field screened for VOCs by use of the total volatile hydrocarbon (TVH) analyzer to determine the presence of hydrocarbon contamination and to select samples for laboratory analysis.

Soil gas samples were collected immediately prior to the in-situ respiration test in laboratory provided, evacuated Summa[®] canisters. Soil gas samples were collected from the 28 feet bgs and 20 feet bgs discrete monitoring points at MPA, and from the 28 feet bgs discrete monitoring point in MPB. All soil gas samples were collected following procedures in the Protocol Document.

The soil samples for laboratory analysis were placed on ice and shipped via Federal Express[®] to the PACE Inc., Laboratory in Huntington Beach, CA. Each soil sample was analyzed for total recoverable petroleum hydrocarbons (TRPH); benzene, toluene, ethylbenzene, and xylenes (BTEX); iron; alkalinity; total Kjeldahl nitrogen (TKN); pH; phosphates; percent moisture; and grain size distribution. Soil gas samples were placed in a shipping box (without ice), and shipped via Federal Express[®] to Air Toxics, Inc., in Folsom, CA for total volatile hydrocarbon (TVH) and BTEX analysis. The results of the soils and soil gas samples are presented in Table 2.1.

2.2 Exceptions to Test Protocol Document Procedures

No exceptions to the Test Protocol Document procedures were conducted during the initial pilot test at Pit 4.

2.3 Field QA/QC Results

Field quality assurance/quality control (QA/QC) samples were not collected or required at this site because the ten percent collection requirement for QA/QC duplicate samples has been met at other AFCEE bioventing test sites.

3.0 PILOT TEST RESULTS

3.1 Initial Soil Gas Chemistry

Prior to initiating any air injection, soil gas in the VW and all MPs were monitoring for TVH, oxygen, and carbon dioxide. The VW and MPs were purged to remove stale soil gas prior to monitoring. Soil gas monitoring was accomplished using portable gas analyzers as described in the Protocol Document. The results of the initial monitoring is presented in Table 3.1.

As shown in Table 3.1, the VW and several MPs had completely depleted oxygen levels (0.0 %), while all points had high carbon dioxide readings (greater than 6 %), and TVH readings ranging from 240 ppm to greater than 5,000 ppm. These readings suggest that the indigenous microorganisms have completely depleted the naturally

TABLE 2.1
SOIL AND SOIL GAS LABORATORY ANALYTICAL RESULTS
FIRE TRAINING PIT 4
Plattsburgh AFB, New York

Analyte (Units) ¹	Sample Location – Depth (feet below ground surface)		
	PL4-MPA-20	PL4-MPA-28	PL4-MPB-28
<u>Soil Gas Hydrocarbons</u>			
TPH (ppmv)	4300	7200	10000
Benzene (ppmv)	3.4	11	18
Toluene (ppmv)	27	9.3	17
Ethylbenzene (ppmv)	26	24	22
Xylenes (ppmv)	92	76	78
<u>Soil Hydrocarbons</u>			
TRPH (mg/kg)	7280	3120	3120
Benzene (mg/kg)	< 1.1	< 1.4	< 2.6
Toluene (mg/kg)	< 1.1	< 1.4	< 2.6
Ethylbenzene (mg/kg)	5.5	13	28
Xylenes (mg/kg)	23	66	150
<u>Soil Inorganics</u>			
Iron (mg/kg)	4960	4950	3560
Alkalinity (mg/kg as CaCO ₃)	< 44	< 44	< 42
pH (units)	6.2	6	7.1
TKN (mg/kg)	64	ND	ND
Phosphates (mg/kg)	370	330	280
<u>Soil Physical Parameters</u>			
Soil Temperature (°F 10' & 28')	NS ²	39.1 & 49.1	NS
Moisture (% wt.)	9.3	10.1	5.5
Gravel (%)	0.0	0.0	0.0
Sand (%)	78.4	59.3	96.2
Silt (%)	19	38.1	2
Clay (%)	2.6	2.6	1.7

¹ TRPH = total recoverable petroleum hydrocarbons; TPH = total petroleum hydrocarbons; mg/kg = milligrams per kilogram; ppmv = parts per million by volume; CaCO₃ = calcium carbonate; TKN = total kjeldahl nitrogen.

² NS = No Sample Collected

TABLE 3.1
 INITIAL SOIL GAS CHEMISTRY
 FIRE TRAINING PIT 4
 Plattsburgh AFB, New York

MP Depth (ft)	O ₂ (%)	CO ₂ (%)	TVH (ppm)
PL4-VW	0.0	10.2	240
PL4-MPA-10	6.0	7.5	360
PL4-MPA-20	0.0	11	3300
PL4-MPA-28	0.0	11.1	4000
PL4-MPB-16	2.0	10	3600
PL4-MPB-22	0.0	11.5	1550
PL4-MPB-28	0.0	11.6	2200
PL4-MPC-16	9.0	6.5	2400
PL4-MPC-22	1.0	10	5000
PL4-MPC-28	0.0	11.8	1800

available oxygen supply, indicating significant biological activity. In contrast, the background monitoring point installed for the pilot test at Pit 3 on Plattsburgh AFB indicated near atmospheric conditions in the soil gas (i.e. greater than 20 % oxygen and less than 0.5 % carbon dioxide) to a depth of at least 30 feet bgs.

3.2 Air Permeability

An air permeability test was conducted according to the Protocol Document procedures on 29 March 1994. Air was injected into the vent well for 60 minutes at a rate of approximately 140 cubic feet per minute (cfm) and an average pressure of ten inches of water. Steady-state pressure levels were achieved at all MPs within the 60 minute test period. Table 3.2 provides the maximum steady-state pressures at each discrete monitoring point.

The dynamic test method was utilized to determine the soil's permeability (Hinchee et al., 1992). Using the HyperVentilate[®] model, an air permeability value ranging from 71 to 188 darcys was calculated for this site. The radius of pressure influence is estimated to exceed 60 feet for this site.

3.3 Oxygen Influence

The depth and radius of oxygen influence in the subsurface resulting from air injection into the central VW is the primary design parameter for bioventing systems. Optimization of full-scale and multiple VW systems require pilot testing to determine the volume of soil that can be oxygenated at a given flow rate and vent well screen configuration.

Table 3.3 presents the change in soil gas oxygen levels that occurred after six hours of continuous air injection. This period of air injection, at approximately 140 cfm, produced an increase in soil gas oxygen concentrations at least 60 feet from the VW. Based on the oxygen increase and the pressure response at the furthest monitoring point (MPC), the long-term radius of oxygen influence will exceed 60 feet when air is injected at a rate of approximately 140 cfm.

3.4 In-Situ Respiration Rates

In-situ respiration tests were performed at the discrete monitoring points MPA-28, MPA-20, and MPB-28. These points were chosen based on their low oxygen readings (0.0 %), high carbon dioxide readings (greater than 11 %), and high TVH readings (greater than 2,000 ppm). A four percent helium in air mixture was injected into each of the three discrete monitoring points for 20 hours during the initial part of the in-situ respiration test. Oxygen, carbon dioxide, and TVH concentrations were then measured in the soil gas at each discrete monitoring point. These readings were collected for approximately 120 hours following cessation of the helium/air injection period. The measured oxygen losses were then used to calculate biological oxygen utilization rates. The results of the in-situ respiration testing for the three points are presented in Figures 3.1 through 3.3. Table 3.4 provides a summary of the oxygen utilization rates.

TABLE 3.2
MAXIMUM PRESSURE RESPONSE
AIR PERMEABILITY TEST
FIRE TRAINING PIT 4
Plattsburgh AFB, New York

	Distance from injection well (PL4-VW)								
	15' (MPA)			30' (MPB)			60' (MPC)		
Depth (feet)	10	20	28	16	22	28	16	22	28
Time (minutes)	45	45	45	45	45	45	60	25	50
Max Pressure (inches H ₂ O)	3.5	3.3	3.0	2.2	2.6	2.5	0.71	0.73	0.68

TABLE 3.3
INFLUENCE OF AIR INJECTION AT VENT WELL
ON MONITORING POINT OXYGEN LEVELS
FIRE TRAINING PIT 4
Plattsburgh AFB, New York

MP	Distance From VW (ft)	Depth (ft)	Initial O ₂ (%)	Final O ₂ (%) Permeability Test
PL4-MPA-10	15	10	0.0	20.9
PL4-MPA-20	15	20	0.0	20.8
PL4-MPA-28	15	28	0.0	18.3
PL4-MPB-16	30	16	2.0	1.5
PL4-MPB-22	30	22	0.0	0.8
PL4-MPB-28	30	28	0.0	4.8
PL4-MPC-16	60	16	9.0	0.5
PL4-MPC-22	60	22	1.0	2.0
PL4-MPC-28	60	28	0.0	3.0

FIGURE 3.1

Respiration Test
 Oxygen and Helium Concentrations
 Fire Training Pit 4 (PL4), MPA-20
 Plattsburgh AFB, New York

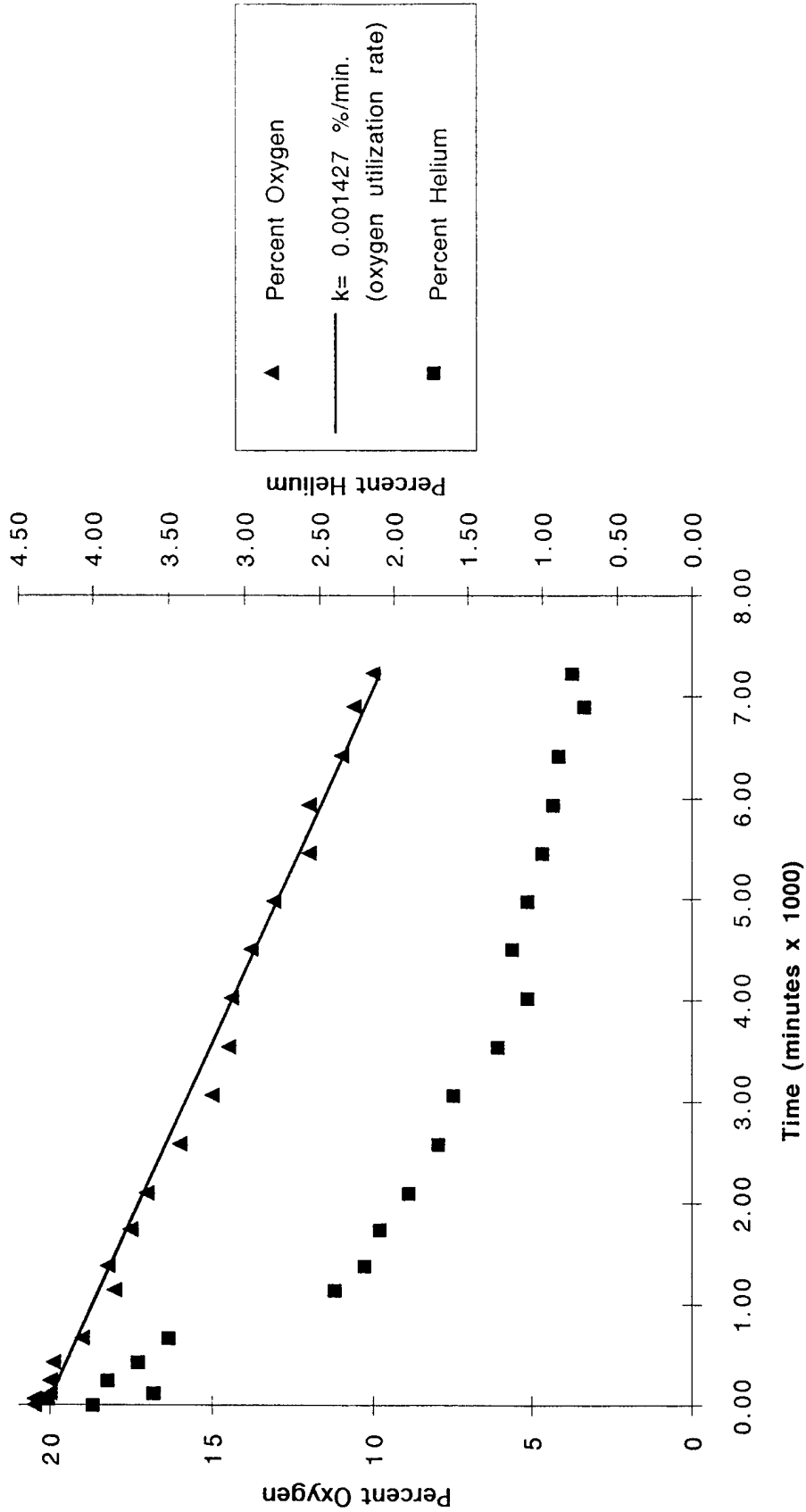

Respiration Test
 Oxygen and Helium Concentrations
 Fire Training Pit 4 (PL4), MPA-28
 Plattsburgh AFB, New York

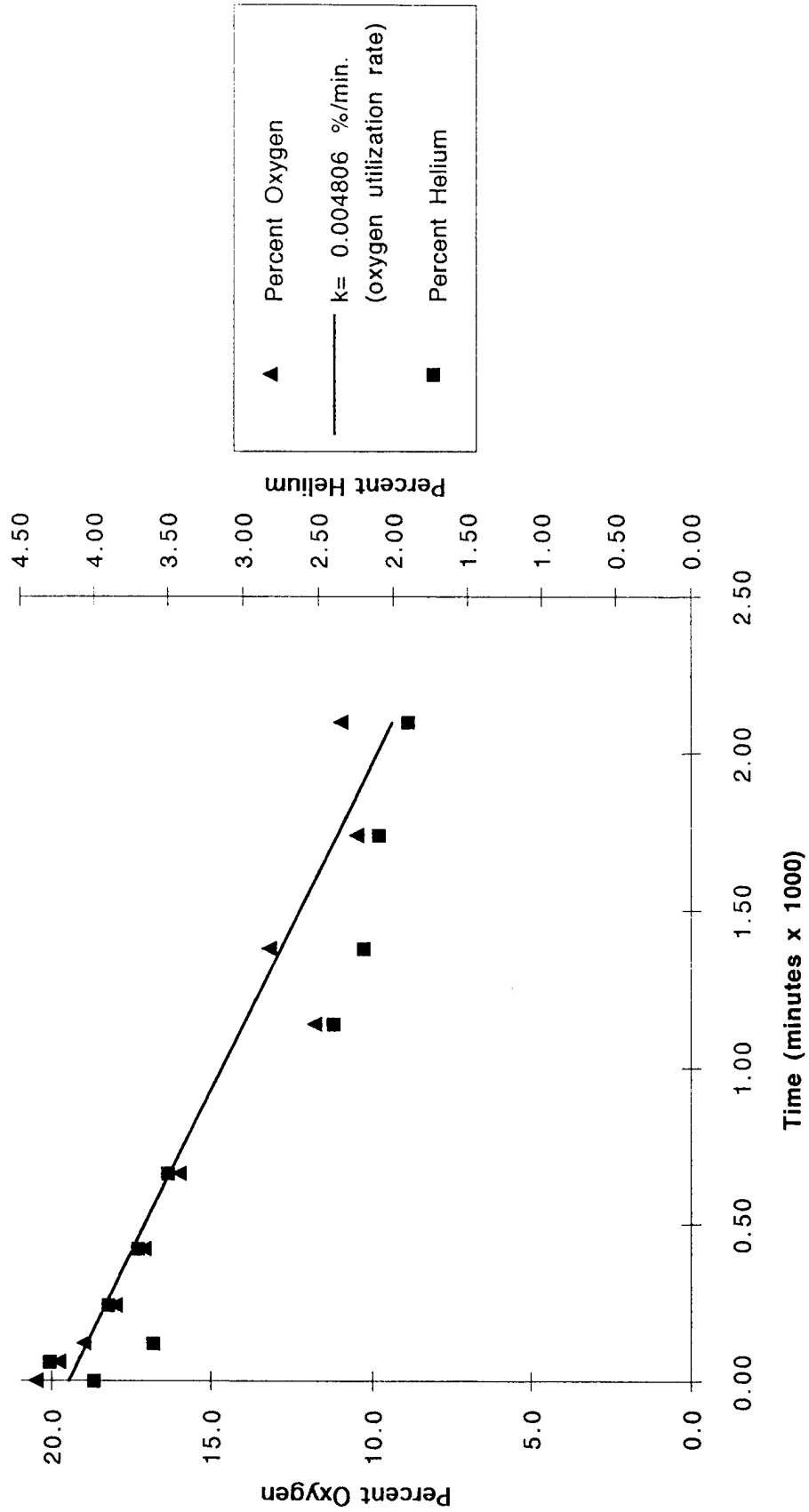

FIGURE 3.2

Respiration Test
 Oxygen and Helium Concentrations
 Fire Training Pit 4 (PL4), MPB-28
 Plattsburgh AFB, New York

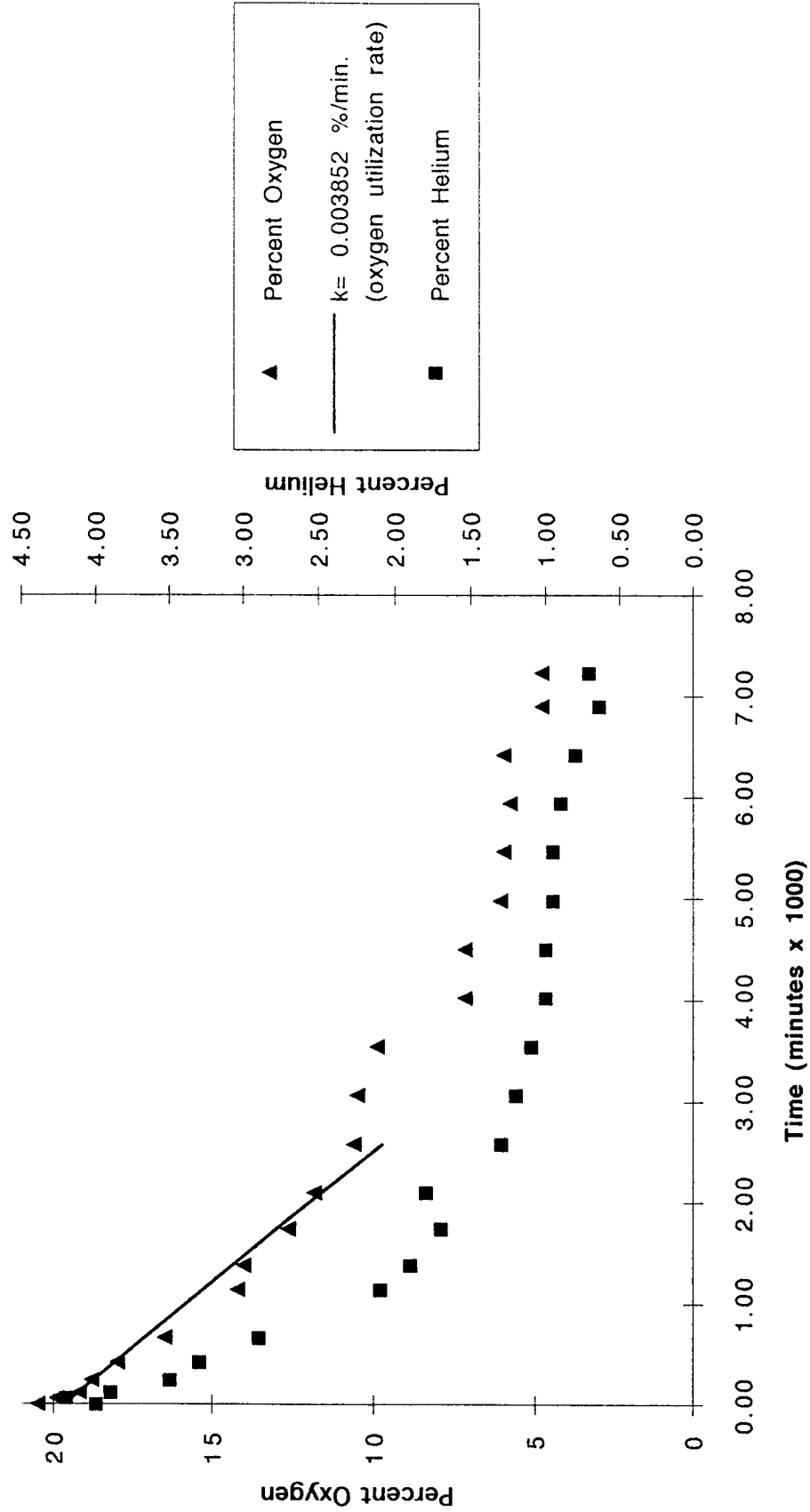

FIGURE 3.3

**TABLE 3.4
OXYGEN UTILIZATION RATES
FIRE TRAINING PIT 4
Plattsburgh AFB, New York**

Monitoring Point	O ₂ Loss ⁽¹⁾ (%)	Test Duration (min)	O ₂ Utilization ⁽¹⁾ Rate (% per min)
MPA-20	10.5	7230	0.0014
MPA-28	14.6	7230	0.0048
MPB-28	15.7	7230	0.0039

¹ Values based on linear regression (Figures 3.1 through 3.3)

Oxygen loss was linear at every point tested during the respiration test. Oxygen utilization rates observed at Pit 4 were very consistent and ranged from 0.0014 to 0.0048 % per min (Table 3.4).

Because helium is a conservative, inert gas, the change in helium concentration over time can be useful in determining the effectiveness of the bentonite seals between each discrete monitoring point in the MPs. Figures 3.1 through 3.3 compare oxygen utilization and helium retention. As shown on the figures, the loss of helium from the soil was approximately the same as the steady rate of oxygen utilization. Because helium will diffuse into a given medium approximately three times faster than oxygen due to helium's lower molecular weight, the measured oxygen loss is primarily the result of bacterial respiration. However, it does appear that a portion of the oxygen loss was due to diffusion in these porous, sandy soils.

At Pit 4, an estimated 620 mg of fuel per kilogram of soil can be degraded each year. This value is the average of the fuel consumption rates calculated for every point at which a respiration test was conducted. The interval-specific fuel consumption rates were calculated using observed oxygen utilization rates, estimated air-filled porosities, and a conservative ratio of 3.5 mg of oxygen consumed for every 1 mg of fuel biodegraded. The air-filled porosity calculated for each sampling point ranged from 0.089 to 0.144 liters of air per kilogram of soil.

3.5 Potential Air Emissions

The long-term potential for air emissions from full-scale bioventing operations at Pit 4 are considered to be low because of the age and type of the site contaminants (greater than five years, and primarily JP4 jet fuel). Additionally, the results of a recent ground surface emission flux test conducted at Pit 3 on Plattsburgh AFB indicate that emission to the atmosphere will be minimal. The site history and contaminants at Pit 3 are very similar to Pit 4, and the flux test conducted at Pit 3 showed an emission rate of less than 0.002 pounds of benzene per day. Additionally, health and safety monitoring conducted during the six hour permeability test using a TVH meter sensitive to 1 ppm did not detect any hydrocarbons either in the breathing zone or at the ground surface. Because the potential for air emissions is highest during the initial air injection period, and no emissions were detected, the long-term air emission potential is considered low. Finally, the site is very isolated on Plattsburgh AFB, and is several thousand feet from any permanently occupied building.

4.0 RECOMMENDATIONS

Initial bioventing test at Pit 4 indicate that naturally occurring oxygen has been depleted in the contaminated soils, and that air injection will be an effective method of increasing aerobic fuel biodegradation. AFCEE has recommended that air injection begin at Pit 4 to determine the long-term radius of oxygen influence and the effects of time, available nutrients and changing temperatures on fuel biodegradation rates.

A 2.5 horsepower regenerative blower has been installed at Pit 4 to inject air at a rate of up to 140 cfm. However, for the single VW currently installed at the site, an air injection rate of 30 to 40 scfm will be used. This size blower was installed to allow for expansion of the bioventing system to include multiple air injection vent wells to

impact an even larger area if necessary in the future. The blower will be electrically connected for the extended pilot test following New York State Regulatory approval to conduct the extended test. After the one-year test period is begun, ES will return to the base at six months and one year to analyze the soil gas and conduct follow-up in-situ respiration tests. Additionally, at the one year point, ES will collect a limited number of soil samples from the Pit 4 area to determine the soil contamination levels after one year of in-situ treatment.

Based on the results of the first year of pilot-scale bioventing, AFCEE will recommend one of three options for the Pit 4 site:

1. Upgrade, if necessary, and continue operation of the bioventing system.
2. If the one year soil samples indicate that significant contamination removal has occurred, AFCEE may recommend additional soil sampling to confirm that the cleanup criteria has been achieved.
3. If significant difficulties or poor results are encountered during the bioventing pilot test, AFCEE may recommend removal of the blower system and proper abandonment of the VW and MPs.

5.0 REFERENCES

- Engineering-Science, Inc. 1993. *Draft Bioventing Test Work Plan for Fire Training Pit 1 and Fire Training Pit 4 and Oil/Water Separator (FT-002)- Plattsburgh AFB, New York.* February.
- Hinchee, R.E., Ong, S.K., Miller, R.N., Downey, D.C., Frandt, R. 1992. *Test Plan and Technical Protocol for a Field Treatability Test for Bioventing.* Columbus, Ohio. January.

APPENDIX A

**REGENERATIVE BLOWER
OPERATIONS AND MAINTENANCE MANUAL**

APPENDIX A
REGENERATIVE BLOWER
OPERATIONS AND MAINTENANCE MANUAL
FOR
EXTENDED TESTING SYSTEM AT
FIRE TRAINING AREA FT-002
PLATTSBURGH AFB, NEW YORK

Prepared for

Air Force Center for Environmental Excellence
Brooks AFB, Texas

and

380th Civil Engineering Squadron and
Environmental Management Branch
Plattsburgh AFB, New York

by

Engineering-Science, Inc
290 Elwood Davis Road
Liverpool, New York

August 1994

TABLE OF CONTENTS

Section 1 Introduction.....	1-1
Section 2 Bioventing System Operation.....	2-1
2.1 Principle of Operation	2-1
2.2 System Description.....	2-1
2.2.1 Blower System.....	2-1
2.2.2 Monitoring Gauges	2-1
Section 3 System Maintenance.....	3-1
3.1 Blower/Motor Maintenance.....	3-1
3.1.1 Lubrication.....	3-1
3.2 Air Filter Maintenance	3-1
3.3 Maintenance Schedule.....	3-2
3.4 Major Repairs.....	3-2
Section 4 System Monitoring.....	4-1
4.1 Blower Performance Monitoring	4-1
4.1.1 Vacuum/Pressure.....	4-1
4.1.2 Flow Rate	4-1
4.1.3 Temperature	4-1
4.3 Monitoring Schedule	4-1
 Appendix A	
 Appendix B	

SECTION 1

INTRODUCTION

This document has been prepared by Engineering-Science, Inc. to support the bioventing initiative contract awarded by the Air Force Center for Environmental Excellence. The contract involves the conducting of bioventing pilot tests at Air Force bases across the United States.

At most sites, bioventing systems will be installed upon completion of the bioventing pilot tests for the purpose of extended pilot testing. These systems will operate for a one year period to provide further information as to the feasibility of the technology at each site, and to provide interim remedial action.

This Operations and Maintenance Manual has been created for sites at which regenerative type blowers have been installed for extended pilot testing. Basic maintenance of these systems is the responsibility of the base. The manual is to be used by base personnel to guide and assist them in operating and maintaining the blower system. Section 2 of this document describes the blower. Section 3 details the maintenance requirements and provides maintenance schedules. Section 4 describes the system monitoring that is required to forecast system maintenance needs and provide data for the extended pilot test. Blower performance curves and relevant service information are provided in Appendix A, and data collection sheets are provided in Appendix B.

SECTION 2

BIOVENTING SYSTEM OPERATION

2.1 PRINCIPLE OF OPERATION

Bioventing is the forced injection of fresh air, or withdrawal of soil gas, to enhance the supply of oxygen for in-situ bioremediation. Either a pressure (air injection) or vacuum (vapor extraction) blower unit is used to inject or withdraw air into or from the soil, thereby supplying fresh air with 20.9 percent oxygen to contaminated soils. Once oxygen is provided to the subsurface, existing bacteria will proceed with the breakdown of fuel residuals.

At Plattsburgh Air Force Base (AFB) a 2¹/₂ horsepower blower system has been installed.

2.2 SYSTEM DESCRIPTION

2.2.1 Blower System

A GAST R5125-1 blower powered by a 2¹/₂ horsepower direct-drive motor is the workhorse of the bioventing system. This blower is rated at 140 scfm at 10 inches of water vacuum; however, the actual performance of the blower will vary with changing site conditions. All systems include an air filter to remove any particulates which are entrained in the air stream and several valves and monitoring gauges which are described in the next section. A schematic of the blower system installed at Plattsburgh AFB, corresponding blower performance curves, and relevant service information are provided in Appendix A.

2.2.2 Monitoring Gauges

The bioventing system is equipped with vacuum and pressure gauges and a temperature gauge. Gauges have been installed on the air injection system at the following locations; a vacuum gauge in the inlet piping and a pressure gauge in the outlet piping. See the system schematic for the locations of the gauges installed on the blower system at this site.

A temperature gauge is located at the outlet of the blower system. This gauge is used to monitor the outlet temperature from the blower. Ambient air temperature should be used to determine the inlet temperature. See the system schematic for the location of the temperature gauge installed on the blower system at this site.

SECTION 3

SYSTEM MAINTENANCE

3.1 BLOWER/MOTOR MAINTENANCE

Although the motor is relatively maintenance free, the system requires periodic maintenance for proper operation and long life. Recommended maintenance procedures and schedules are described in detail in the instruction manual included in Appendix A and briefly summarized in this section. The blower and motor should not require any periodic maintenance during the 1-year extended testing period.

Filter inspection must be performed with the system turned off. To re-start the motor, open the manual bypass valve to protect the motor from excessive strain, start motor, and slowly close bypass valve to its original setting. If the handle has been removed from the manual air dilution valve, do not open the valve or otherwise change the setting (it has been pre-set for a specific flow rate) before re-starting the blower.

3.1.1 Lubrication

Regenerative blowers require no lubrication.

3.2 AIR FILTER MAINTENANCE

To avoid damage caused by passing solids through the blower an air filter has been installed in-line before the blower.

The filter element is paper and is accompanied by a polyurethane foam prefilter. The filter should be checked weekly for the first two months of operation. Again, a base employee should determine the best schedule for filter replacement. The polyurethane prefilters can be washed with lukewarm water and a mild detergent. Paper filter elements should never be washed but should be disposed of and replaced as necessary. When the pressure or vacuum drop across the filter is above 15 inches of water, a dirty filter element should be suspected and cleaning or replacement should be performed.

To remove the filter, loosen the three clamps or the wing nut, lift the metal top off the air filter, and lift the air filter from the metal housing. Remove the polyurethane prefilter (if applicable) and wash before replacing. When replacing the filter, be careful that the rubber seals remain in place.

The filter is manufactured by Solberg Manufacturing, Inc. in Itasca, Illinois. Their telephone number is (708) 773-1363. Additional filters can also be obtained through Engineering-Science, Inc. in Liverpool, New York. The ES contacts are Mr. David Brown and Mr. Richard Moravec and they can be reached at (315) 451-9560.

3.3 MAINTENANCE SCHEDULE

The following maintenance schedule is recommended for this system. During the initial months of operation more frequent monitoring is recommended to ensure that any stat up problems are quickly corrected. A daily drive-by inspection is

recommended during the initial two weeks of operation to ensure that the blower system is still operating with no unusual sounds. Data collection sheets have been provided to assist your data collection and are included in Appendix B.

Maintenance Item

Maintenance Frequency

Filter

Check once per month. Wash or replace as necessary.

3.4 MAJOR REPAIRS

Blower systems are very reliable when properly maintained. Occasionally, a motor or blower will develop serious problems. If a blower system fails to start, and a base electrician verifies that power is available at the starter, the Engineering-Science site manager, Dave Brown, should be called at (315) 451-9560. Engineering-Science is responsible for major repairs during the first year of operation.

SECTION 4

SYSTEM MONITORING

4.1 BLOWER PERFORMANCE MONITORING

To monitor the blower performance, vacuum, pressure and temperature will be measured. These data should be recorded weekly on a data collection sheet provided in Appendix B. All measurements should be taken at the same time while the system is running. Since the System is loud, ear protection should be worn at all times.

4.1.1 Vacuum/Pressure

With ear protection on, record all vacuum and pressure readings directly from the gauges (in inches of water). Record the measurements on the data collection sheet provided in Appendix B.

4.1.2 Flow Rate

The flow rate through the vent well and soils can be calculated when the inlet vacuum and outlet pressure of the blower are known. This pressure change across the blower (vacuum + pressure) can be compared to the performance curves for the blower in Appendix A to determine the approximate flow rate.

4.1.3 Temperature

With ear protection on, record the temperature readings directly from the gauge in degrees Fahrenheit. Record the measurements on the data collection sheet provided in Appendix B. The temperature change can be converted to degrees Celsius ($^{\circ}\text{C}$) using the formula $^{\circ}\text{C} = (^{\circ}\text{F} - 32) \times 5/9$.

4.3 MONITORING SCHEDULE

The following monitoring schedule is recommended for this system. During the initial months of operation more frequent monitoring is recommended to ensure that any start up problems are quickly corrected. Data collection sheets have been provided to assist your data collection and are included in Appendix B.

<u>Monitoring Item</u>	<u>Monitoring Frequency</u>
Vacuum/Pressure	Daily during first week, then once per week.
Temperature	Daily during first week, then once per week.

APPENDIX A



Post Office Box 97
Benton Harbor, Michigan 49023-0097
Ph: 616/926-6171
Fax: 616/925-8288

Maintenance Instructions for Gast Standard Regenerative Blowers

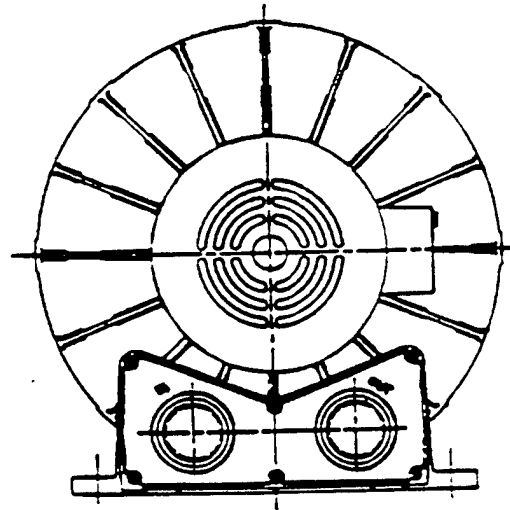
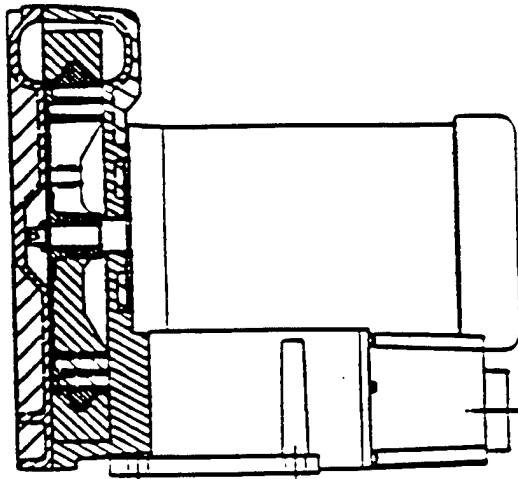

For original equipment manufacturers
special models, consult your local distributor

Gast Rebuilding Centers

Gast Mfg. Corp.
2550 Meadowbrook Rd.
Benton Harbor MI. 49022
Ph: 616/926-6171
Fax: 616/925-8288

Gast Mfg Corp.
505 Washington Avenue
Carlstadt, N. J. 07072
Ph: 201/933-8484
Fax: 201/933-5545

Brenner Fiedler & Assoc.
13824 Benitey Place
Cerritos, CA. 90701
Ph: 213/404-2721
Fax: 213/404-7975

Wainbee, Limited
121 City View Drive
Toronto, Ont. Canada M9W 5A9
Ph: 416/243-1900
Fax: 416/243-2336

Wainbee, Limited
215 Brunswick Drive
Pointe Claire, P.Q. Canada H9R 4R7
Ph: 514/697-8810
Fax: 514/697-3070

Gast Mfg. Co. Limited.
Halifax Rd, Cressex Estate
High Wycombe, Bucks HP12 3SN
Ph. 44 494 523571
Fax: 44 494 436588

Japan Machinery Co. Ltd.
Central PO Box 1451
Tokyo 100-91 Japan
Ph: 813/3573-5421
Fax: 813/3571-7865

1st

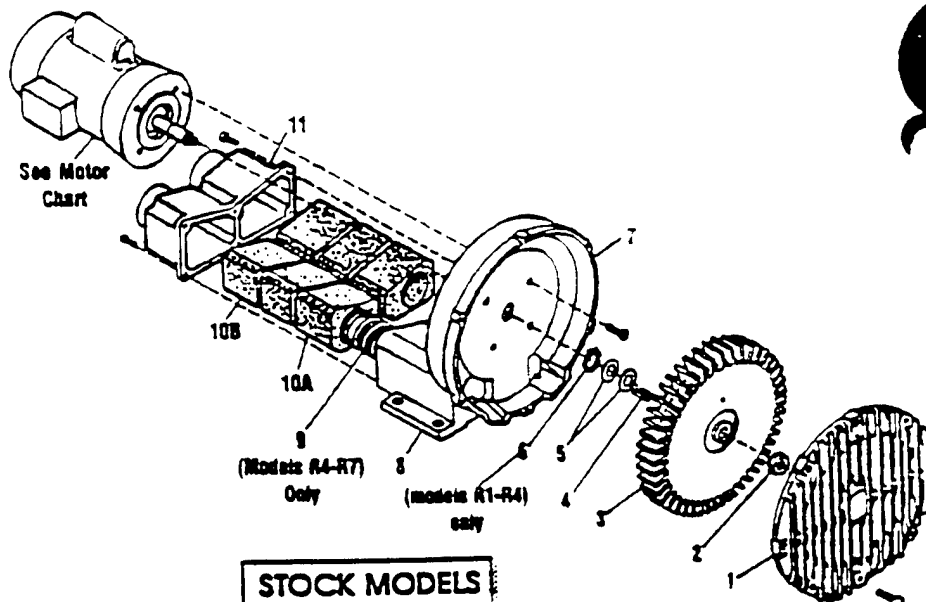

STOCK MODELS

Part Name	R1	R2	R3	R4	R5	R6	R6P	R6PP/R6PS	R7
#1 Cover	AJ101A	AJ101B	AJ101C	AJ101D	AJ101EQ	AJ101F	AJ101K	(2)AJ101KA	AJ101G
#2 Stopnut	BC187	BC187	BC181	BC181	BC181	BC181	BC181	(2)BC182	BC183
#3 Impeller	AJ102A	AJ102B	AJ102C	AJ102D	AJ102E	AJ102F	AJ102K	(2)AJ102KA	AJ102GA
#4 Square Key	AH212C	AH212	AB136A	AB136D	AB136	AB136	AB136	(2)AB136	AC628
#5 Shim Spacer (s)	AJ132	AE686-3	AJ109	AJ109	AJ109	AJ116A	AJ116A	AJ116A	AJ110
#6 Retaining Ring	AJ145	AJ145	AJ149	AJ149					
#7 Housing	AJ103A	AJ103B	AJ103C	AJ103DR	AJ103E	AJ103F	AJ103K	AJ103KD	AJ103GA
#8 Muffler Box					AJ104E	AJ104F			
#9 Spring				AJ113DR	AJ113DQ	AJ113FQ	AJ113FQ		AJ113G
#10A Foam	(4)AJ112A	(4)AJ112B	(4)AJ112C	(4)AJ112DS	(4)AJ112ER	(6)AJ112F	(8)AJ112K		(8)AJ112GA
#10		(2)AJ112BQ	(2)AJ112CQ	(2)AJ112DR	(2)AJ112EQ				
#11 Motor Extension/ Motor Plate	AJ106H	AJ106BQ	AJ106CQ	AJ106DQ	AJ106EQ	AJ106FQ	AJ104K		AJ104GA
Shim Kit	K396	K396							K396

MOTOR CHART

REGENAIR MODEL NUMBER	MOTOR NUMBER	MOTOR SPECIFICATIONS		
		60 HZ VOLTS	50 HZ VOLTS	PHASE
R1102	J111X	115/208-230	110/220-240	1
R1102C	J112X	115		1
R2103	J311X	115/208-230	110/220	1
R2105	J411X	115/208-230	110/220	1
R2303A	J310	208-230/460	220/380-415	3
R2303F	J313	208-230	220	3
R3105-1/R3105-12	J411X	115/208-230	110/220-240	1
R3305A-1/R3305A-13	J410	208-230/460	220/380-415	3
R4110-2	J611AX	115/208-230	110/220-240	1
R4310A-2	J610	208-230/460	220/380-415	3
R5125-2	J811X	115/208-230		1
R5325A-2	J810X	208-230/460	220/380-415	3
R6125-2	J811X	115/208-230		1
R6325A-2	J810X	208-230/460	220/380-415	3
R6335A-2	J910X	208-230/460	220/380-415	3
R6150J-2	J1013	230		1
R6150A-2	J1010	208-230/460	220/380-415	3
R6150A	J910X	208-230/460	220/380-415	3
R6150A	J1010	208-230/460	220/380-415	3
R6P355A	J110A	208-230/460	220/380-415	3
R7100A-2	J120B	208-230/460	220/380-415	3
R6PP/R6PS110M	JD1100	208-230/460	220/380-415	3

* No lubrication needed at start up. Bearings lubricated at factory.

* Motor is equipped with demite fitting. Clean tip of fitting and apply grease gun. Use 1 to 2 strokes of high quality ball bearing grease.

Consistency	Type	Typical Grease
Medium	Lithium	Shell Daxium R

Hours of service per year	Suggested Retube Interval
5,000	3 years
Continual Normal Application	1 year
Seasonal service motor idle for 6 months or more	1 year beginning of season 6 months

Continuous-high ambient, dirty or moist applications.

60 HZ FLOW DATA (CFM)

All performance figures relate to stock models. A few high pressure units may be available. Consult your local distributor.

Regenair Model Number	P R E S S U R E						Maximum Pressure "H ₂ O"
	0"H ₂ O	20"H ₂ O	40"H ₂ O	60"H ₂ O	80"H ₂ O	100"H ₂ O	
R1	26	14					28
R2	42	26					38
R3105-1	52	38	14				42
R3105-12	52	36	23				55
R3305A-13	52	36	23				55
R4	90	70	50				52
R5	145	130	100				65
R6125-2	200	180					35
R6325A-2	200	180	152				40
R6335A-2	205	175	155	135			70
R6350A-2	200	180	150	130	110	80	105
R6P335A	290	250					30
R6P350A	300	260	230	200			60
R6P355A	300	260	230	200	160		90
R7100A-2	420	380	340	310	280	230	115
R6PP311OM	485	452	420	380	330		65
R6PS311OM	265	258	252	244	236	226	170

Regenair Model Number	V A C U U M					Maximum Vacuum "H ₂ O"
	0"H ₂ O	20"H ₂ O	40"H ₂ O	60"H ₂ O	80"H ₂ O	
R1	25	14				26
R2	40	22				34
R3105-1	50	34	9			40
R3105-12	51	34	20			50
R3305A-13	51	34	20			50
R4	82	62	39			48
R5	140	115	90	50		60
R6125-2	190	155	125			45
R6325A-2	190	155	125			45
R6335A-2	190	150	125	100		75
R6350A-2	190	180	150	100	70	90
R6P335A	270	230				37
R6P350A	280	240	210	170		70
R6P355A	280	240	210	170	100	86
R7100A-2	410	350	300	250	170	90
R6PP311OM	470	425	375	320	220	80
R6PS311OM	240	225	210	195	175	130

This number indicates the maximum static pressure differential recommended (with cooling air still flowing through unit). In general, units 1hp or less can be dead headed. Check with local representative or distributor to verify which models apply.

Operation of the blower above the recommended maximum duty will cause premature failure due to the build up of heat damaging the components.

Performance data was determined under the following conditions:

- 1) Unit in a temperature stable condition.
- 2) Test conditions: inlet air density at 0.075 lbs. per cubic foot. (20°C(68°F), 29.92 in. Hg(14.7PSIA)).
- 3) Normal performance variations on the resistance curve within +/- 10% of supplied data can be expected.
- 4) Specifications subject to change without notice.
- 5) All performance at 60Hz operation.

Wiring Diagrams for Regenerative Blowers

Models R1102, R2103, R3105-1, R4110-2, R5125-2, R6125-2

Low Voltage *Single Phase*

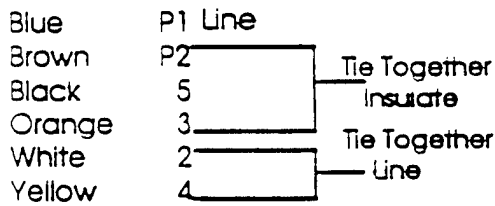

High Voltage *Single Phase*

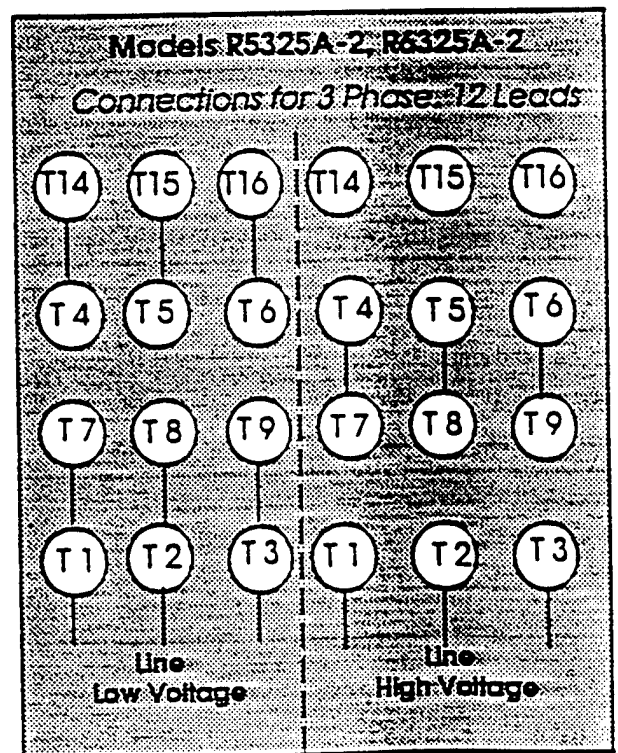
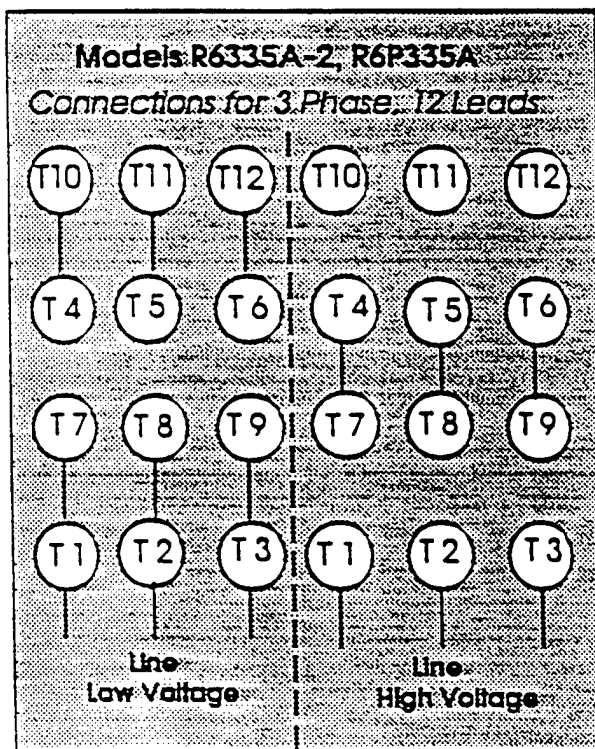
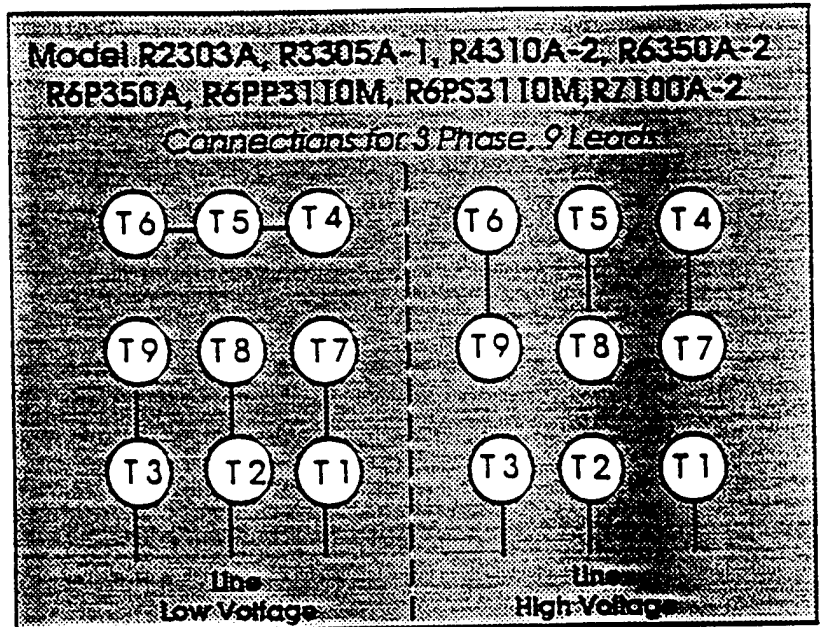
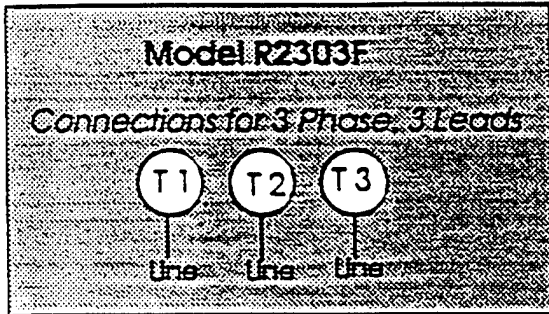
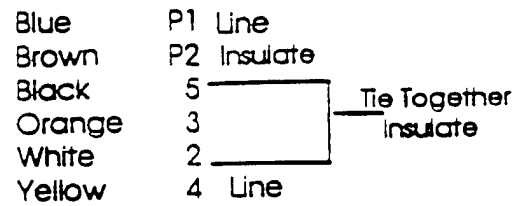

To reverse rotation on any three phase motor, interchange any two external motor line connections to any two line leads.

Safety

⚠ This is the safety alert symbol. When you see this symbol, personal injury is possible. The degree of injury is shown by the following signal words:

- ⚠ DANGER:** Severe injury or death will occur if hazard is ignored.
 - ⚠ WARNING:** Severe injury or death can occur if hazard is ignored.
 - ⚠ CAUTION:** Minor injury or property damage can occur if hazard is ignored.
- Review the following information carefully before operating.

General Information

⚠ DANGER: Do not pump flammable or explosive gases or operate in an atmosphere containing them. Ambient temperature for normal operation should not exceed 40 degrees C (105 degrees F). For higher ambient operation, consult the factory. Blower performance is reduced by the lower atmospheric pressure of high altitudes. If it applies to this unit, consult a Gas distributor or the factory for details.

Installation

⚠ WARNING: Electric Shock can result from bad wiring. Wiring must conform to all required safety codes and be installed by a qualified person. Grounding is required.

The Gast Regenair blower can be installed in any position. The flow of cooling air over the blower and motor must not be blocked.

PLUMBING - The threaded pipe ports are designed as connection ports only and will not support the plumbing. Be sure to use the same or larger size pipe and fittings to prevent air flow restriction and over-heating of the blower. When installing plumbing, be sure to use a small amount of pipe thread lubricant. This protects the threads in the aluminum blower housing. Dirt and chips, often found in new plumbing, should not be allowed to enter the blower.

NOISE - To reduce noise and vibration, the unit should be mounted on a solid surface that will not increase sound. The use of shock mounts or vibration isolation material is recommended. If needed, inlet or discharge noise can be reduced by attaching muffler assemblies (see accessories).

ROTATION - The Gast Regenair blower should only rotate clockwise as viewed from the electric motor side. This is marked with an arrow in the casting. Proper rotation can be confirmed by checking air flow at the IN and OUT ports. On blowers powered by a three phase motor, rotation is reversed by changing any two of the three power wires.

Operation

⚠ WARNING: Solid or liquid material exiting the blower or piping can cause eye damage or skin cuts. Keep away from air stream.

⚠ CAUTION: Attach blower to solid surface before starting. Prevent injury or damage from unit movement. Air containing solid particles or liquid must pass through a filter before entering the blower (see accessories list for filter suggestions). Blowers must have mufflers, filters, other accessories and all piping attached before starting. Any foreign material passing through the blower may cause internal damage.

⚠ CAUTION: Outlet piping can burn skin. Guard or limit access. Mark "CAUTION Hot surface. Can cause burns."

Air temperature increases when passing through the blower. When run at duties above 50 in. H₂O, metal pipe may be required for hot exhaust air.

The blower must not be operated above the limits for continuous duty. "Standard" R1, R2, R3 and R4 can operate continuously with not air flowing through the blower. Other units can only be run at the rating shown on the model number label. Do not close off inlet (for vacuum) or exhaust (for pressure) to reduce extra air flow. This could cause added heat and motor load.

ACCESSORIES - Gast pressure gauges AJ496 or AE133 and vacuum gauges AJ497 or AE134 show blower duty. The Gast pressure/vacuum relief valve, AG258, will limit the operating duty by admitting or relieving air. It also allows full flow through the blower when the relief valve closes.

Servicing

⚠ WARNING: Disconnect electric power before servicing. Be sure rotating parts have stopped. Electric shock or severe cuts can result. Inlet and exhaust filters need occasional cleaning or replacement of the elements. Failure to do so will result in more pressure drop, reduced air flow and hotter operation. The outside of the unit requires cleaning of dust and dirt. The inside of the blower also may need cleaning to remove material coating the impeller and housing. If not done, the buildup can cause vibration, hotter operation and reduced flow. Noise absorbing foam in the mufflers may need replacement. **KEEP THIS INFORMATION WITH THE BLOWER. REFER TO IT FOR SAFE INSTALLATION, OPERATION OR SERVICE.**

TROUBLESHOOTING		
Symptom	Possible Diagnosis	Possible Remedy
Excess Vibration	Impeller damaged by foreign material Impeller contaminated by foreign material	Replace impeller Clean impeller; install adequate filtration
Abnormal sound	Motor bearing failed Impeller rubbing against cover or housing	Replace bearings Repair blower; check clearances
Increase in sound	Foreign material can coat or destroy muffler foam	Replace foam muffler elements; trap or filter foreign material
Blown fuse	Electrical wiring problem	Have qualified person check fuse capacity and wiring
Unit very hot	Running at too high a pressure or vacuum	Install a relief valve

REGENAIR ACCESSORIES

Inline Filters (for vacuum)

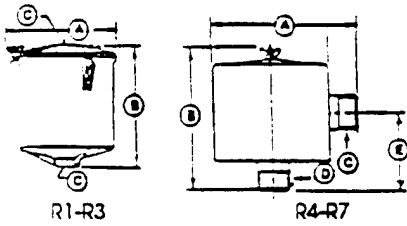

Model Number	R1 & R2	R3	R4, R5 ASDR4	R6 SDR5, SDR6 R6PP, R6PS	R7
Part #	AV460	AV460C	AG337	AJ151G	AJ151H
Dim A	8.25"	8.25"	11.75"	8.00"	16.25"
Dim B	3.875"	3.875"	4.75"	10.25"	27.13"
Dim C	1" FPT	1 1/4" FPT	1 1/2" MPT	2 1/2" MPT	3" MPT
Dim D	-	-	1 1/2" FPT	2 1/2" MPT	3" MPT
Dim E	-	-	2.38	5.50	18.50
Replacement Element	AV469	AV469	AG340	AJ135G	AJ135C
Micron	10	10	25	10	10

MPT = Male Pipe Thread
FPT = Female Pipe Thread

Inlet Filters (for pressure units only)

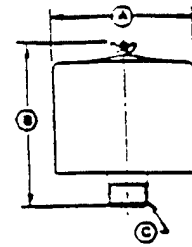

Model Number	R1 & R2	R3	R4, R5 ASDR4	R6, SDR5 SDR6, R6P R6PP, R6PS	R7
Part #	AJ126B	AJ126C	AG338	AJ126F	AJ126G
Dim A	6.00"	6.00"	10.63"	10.63"	10.00"
Dim B	4.62"	7.12"	4.81"	4.81"	13.12"
Dim C	1" MPT	1 1/4" MPT	1 1/2" FPT	2" FPT	2 1/2" MPT
Replacement Element	AJ134B	AJ134C	AG340	AG340	AJ135A
Micron	10	10	25	25	10

All are heavy duty for high amounts of particulates. Inlet filters for REGENAIR blowers are drip-proof when mounted as shown.

Mufflers

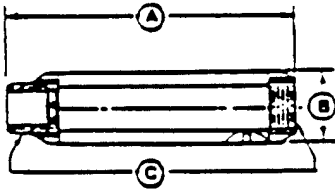

Number	R2	R3	R4, R5 SDR 4" ASDR5"	R6, SDR6" R6P R6PP, R6PS	R7
Part #	AJ121B	AJ121C	AJ121D	AJ121E	AJ121G
Dim. A	7.46"	7.94"	12.75"	17.05"	17.44"
Dim. B	2.38"	2.62"	3.25"	3.63"	4.25"
Dim. C	1" NPT	1 1/4" NPT	1 1/2" NPT	2" NPT	2 1/2" NPT

* For Inlet Only
** Approximately

Pressure-Vacuum Gauge



Pressure Gauge, Part #AJ496, 2 5/8" Diameter, 1/4" NPT, 0-60 inches H₂O and 0-150 mbar

Pressure Gauge, Part #AE133A, 2 5/8" Diameter, 1/4" NPT, 0-200 inches H₂O and 0-500 mbar

Vacuum Gauge, Part #AJ497, 2 5/8" Diameter, 1/4" NPT, 0-60 inches H₂O and 0-150 mbar

Vacuum Gauge, Part #AE134, 2 5/8" Diameter, 1/4" NPT, 0-160 inches H₂O and 0-400 mbar

Fittings

Pipe Size	1"	1 1/4"	1 1/2"	2"	2 1/2"
Tee	3A415	3A431	3A432	3A433	3A434
Common Elbow	3A220	3A244	3A230	3A247	3A248
Nipple	3A752	3A809	3A783	3A810	3A813
Plastic Male Pipe Hose Barb	AJ117A	AJ117B	-	-	-
Hose I.D.	1.25	1.25	-	-	-
Metal Male Pipe Hose Barb	AJ117D	AJ117F	AJ117C	AJ117G	AJ117H
Hose I.D.	1.00	1.25	1.50	2.50	3.00

Relief Valve

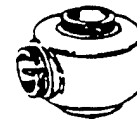

Pressure/Vacuum Relief Valve, Part #AG258, 1 1/2" NPT, Adjustable 30-170 inches H₂O, 200 CFM maximum

Silencer for Relief Valve, Part #AJ121D

Horizontal Swing Type Check Valve

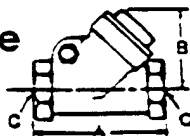

Model Number	R1, R2	R3	R4, R5 SDR 4 ASDR5	R6, SDR6 R6P R6PP, R6PS	R7
Part #	AH326B	AH326C	AH326D	AH326F	AH326G
Dim. A	3.57	4.19	4.50	5.25	8
Dim. B	2.32	2.69	2.94	3.82	5.07
Dim. C	1" NPT	1 1/4" NPT	1 1/2" NPT	2" NPT	2 1/2" NPT

Product Specifications

Model Number	Motor Specs	Full Load Amps	HP	RPM	Max Pressure		Max Flow		Net WL	
					H ₂ O	mbar	cfm	m ³ /hr	lbs.	kg
R4110-2	110/220-240-50-1	9.0/4.5-5.7	0.6	2850	38	95	74	126	41	18.6
	115/208-230-60-1	9.8/5.2-4.9	1.0	3450	52	130	92	156		
R4310A-2	190-220/380-415-50-3	2.6-3.3/1.3-1.4	0.8	2850	38	95	74	126	41	18.6
	208-230/460-60-3	3.4-3.2/1.6	1.0	3450	52	130	92	156		

Product Performance (Metric U.S. Imperial)

Black line on curve is for 60 cycle performance.
Blue line on curve is for 50 cycle performance.

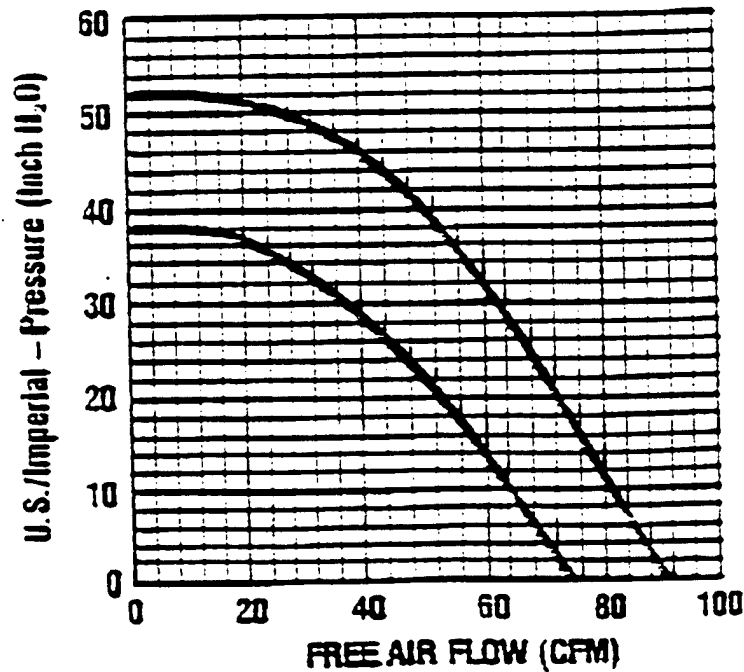
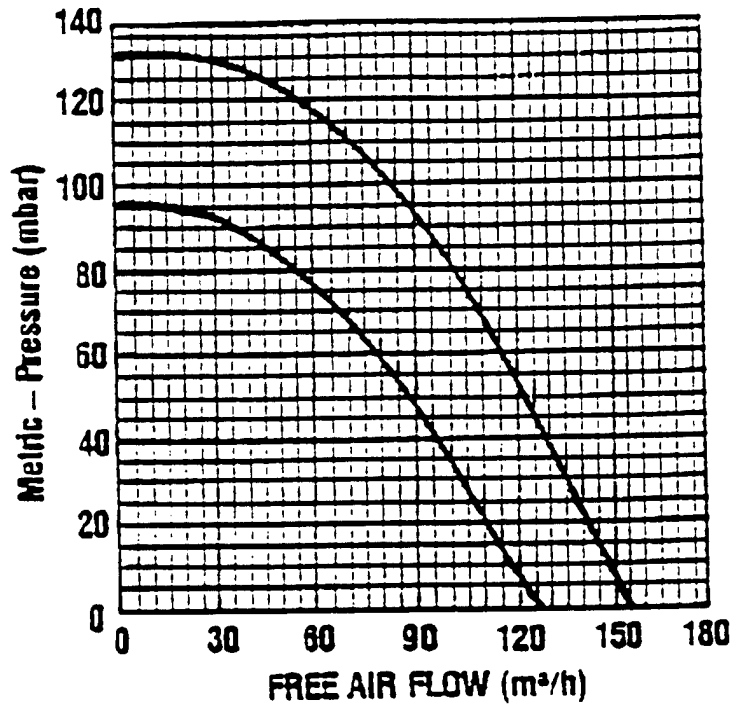

Product Specifications

Model Number	Motor Specs	Full Load Amperes	HP	RPM	Max Pressure		Max Flow		Net Wt.	
					H ₂ O	mbar	cfm	m ³ /h	lbs.	kg
R5325A-2	190-220/380-415-50-3	6.6-6.7/3.3-3.5	1.35	2850	50	125	133	226	65	29.5
	208-230/460-3	6.9/3.45	2.5	3450	65	162	160	272		
R5125-2	115/208-230-60-1	22.4/12.4-11.2	2.5	3450	60	149	160	272	73	33.1

Product Performance (Metric U.S. Imperial)

Black line on curve is for 60 cycle performance.
Blue line on curve is for 60 cycle performance.

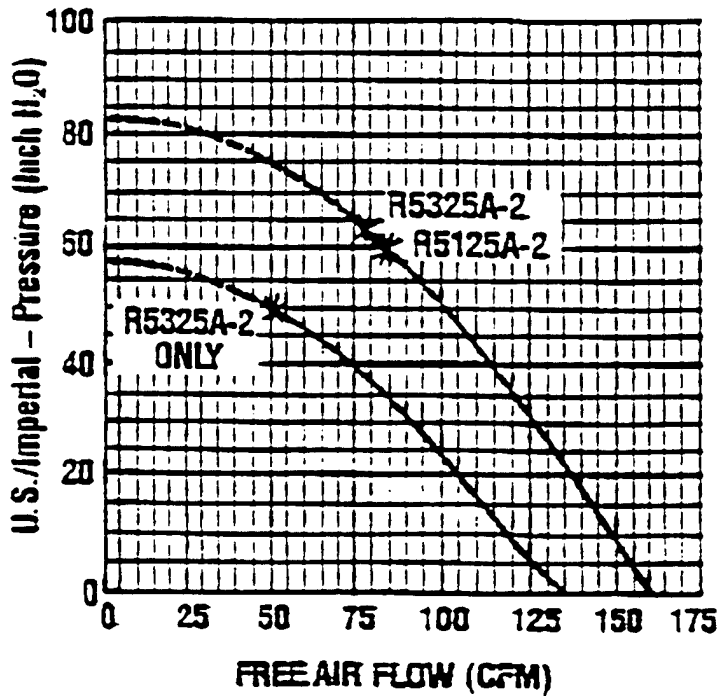
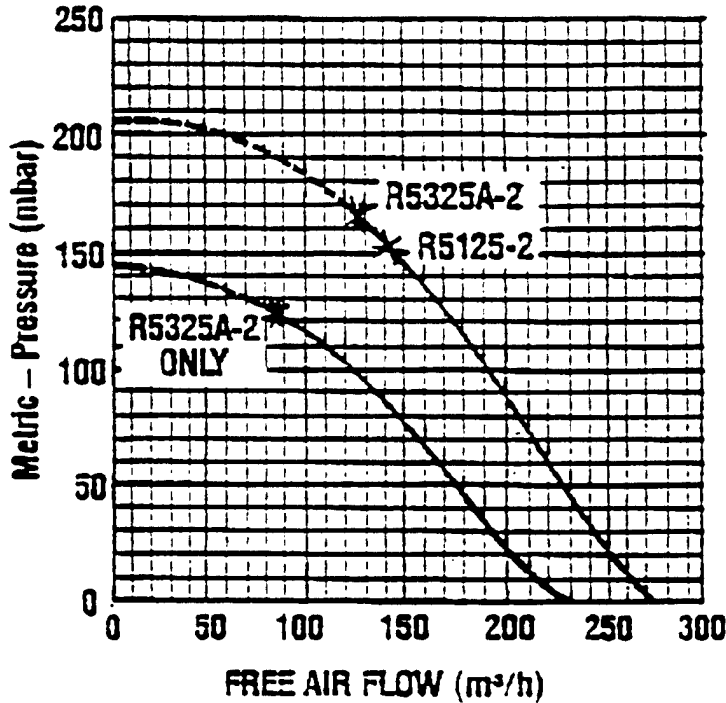

Recommended maximum duty.
--- Intermittent duty only.

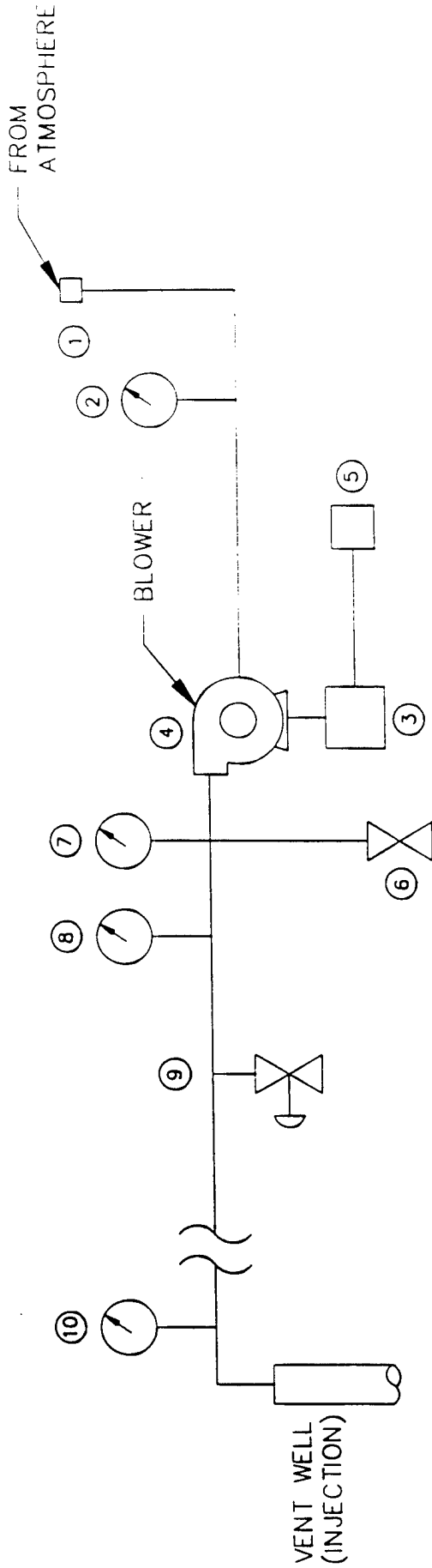

- ① INLET FILTER
- ② VACUUM GAUGE - INCHES OF H2O
- ③ DRIVE MOTOR
2.5 HP / 3450 RPM @ 60 Hz / 230 v / SINGLE PHASE / 15 A
- ④ BLOWER - GAST R5125
145 SCFM @ 3450 RPM / REGENERATIVE
- ⑤ STARTER
230 v / 27 A / SINGLE PHASE
- ⑥ AUTOMATIC PRESSURE RELIEF VALVE - SET @ 50 INCHES H2O
- ⑦ PRESSURE GAUGE (INCHES OF H2O)
- ⑧ THERMOMETER (FAHRENHEIT)
- ⑨ MANUAL PRESSURE RELIEF (BLEED) VALVE - 1 1/2" BALL
- ⑩ AIR VELOCITY MEASUREMENT PORT

SCHEMATIC OF BLOWER
SYSTEM FOR AIR INJECTION
FIRE TRAINING PIT 4
PLATTSBURGH AFB, NEW YORK

ENGINEERING - SCIENCE, INC.
5701 1st Ave. New York



APPENDIX B

