

LOAN DOCUMENT

PHOTOGRAPH THIS SHEET

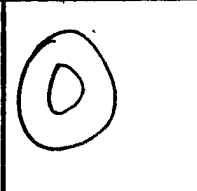

INVENTORY

DTIC ACCESSION NUMBER

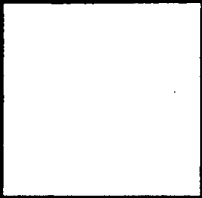

LEVEL

Bioventing Test Work Plan - Interim

DOCUMENT IDENTIFICATION

Jan 94

DISTRIBUTION STATEMENT A

Approved for Public Release
Distribution Unlimited

DISTRIBUTION STATEMENT

ACCESSION FOR	
NTIS	GRAM <input checked="" type="checkbox"/>
DTIC	TRAC <input type="checkbox"/>
UNANNOUNCED JUSTIFICATION	
BY	
DISTRIBUTION/	
AVAILABILITY CODES	
DISTRIBUTION	AVAILABILITY AND/OR SPECIAL
A-1	

DISTRIBUTION STAMP

DATE ACCESSIONED

DATE RETURNED

DTIC QUALITY INSPECTED 4

20001208 116

DATE RECEIVED IN DTIC

REGISTERED OR CERTIFIED NUMBER

PHOTOGRAPH THIS SHEET AND RETURN TO DTIC-FDAC

H
A
N
D
L
E

W
I
T
H

C
A
R
E

DRAFT

**BIOVENTING TEST WORK PLAN AND
INTERIM TEST RESULTS REPORT FOR
BULK FUEL STORAGE AREA
PEASE AIR FORCE BASE, NEW HAMPSHIRE**

ENGINEERING-SCIENCE
ES

Prepared For
Air Force Center for Environmental Excellence
Brooks AFB, Texas
and
AFBDA Operating Location A
Pease AFB, New Hampshire

Prepared By
ENGINEERING-SCIENCE, INC.

January 1994

290 Elwood Davis Road
Liverpool, New York 13088

AQM01-03-0417

DEFENSE TECHNICAL INFORMATION CENTER REQUEST FOR SCIENTIFIC AND TECHNICAL REPORTS

Title AFCEE Collection

1. Report Availability (Please check one box)
 This report is available. Complete sections 2a - 2f.
 This report is not available. Complete section 3.

2a. Number of Copies Forwarded
Each

2b. Forwarding Date
July/2000

2c. Distribution Statement (Please check ONE box)
DoD Directive 5230.24, "Distribution Statements on Technical Documents," 18 Mar 87, contains seven distribution statements, as described briefly below. Technical documents MUST be assigned a distribution statement.

- DISTRIBUTION STATEMENT A: Approved for public release. Distribution is unlimited.
- DISTRIBUTION STATEMENT B: Distribution authorized to U.S. Government Agencies only.
- DISTRIBUTION STATEMENT C: Distribution authorized to U.S. Government Agencies and their contractors.
- DISTRIBUTION STATEMENT D: Distribution authorized to U.S. Department of Defense (DoD) and U.S DoD contractors only.
- DISTRIBUTION STATEMENT E: Distribution authorized to U.S. Department of Defense (DoD) components only.
- DISTRIBUTION STATEMENT F: Further dissemination only as directed by the controlling DoD office indicated below or by higher authority.
- DISTRIBUTION STATEMENT X: Distribution authorized to U.S. Government agencies and private individuals or enterprises eligible to obtain export-controlled technical data in accordance with DoD Directive 5230.25, Withholding of Unclassified Technical Data from Public Disclosure, 6 Nov 84.

2d. Reason For the Above Distribution Statement (in accordance with DoD Directive 5230.24)

2e. Controlling Office
HQ AFCEE

2f. Date of Distribution Statement Determination
15 Nov 2000

3. This report is NOT forwarded for the following reasons. (Please check appropriate box)

- It was previously forwarded to DTIC on _____ (date) and the AD number is _____
- It will be published at a later date. Enter approximate date if known. _____
- In accordance with the provisions of DoD Directive 3200.12, the requested document is not supplied because:

Print or Type Name
Laura Peña
Telephone
210-536-1431

Signature
Laura Peña
(For DTIC Use Only)
AQ Number N101-03-0417

PART I
DRAFT BIOVENTING TEST WORK PLAN FOR
BULK FUEL STORAGE AREA
PEASE AFB, NEW HAMPSHIRE

Prepared for

Air Force Center for Environmental Excellence
Brooks AFB, Texas

and

AFBDA Operating Location A
Pease Air Force Base, New Hampshire

by

Engineering-Science, Inc
290 Elwood Davis Road
Liverpool, New York

August 1993

TABLE OF CONTENTS

1.0 INTRODUCTION.....	1
2.0 SITE DESCRIPTION	2
2.1 Site Location and History.....	2
2.2 Site Geology.....	2
2.3 Site Contaminants.....	5
3.0 PILOT TEST ACTIVITIES.....	5
3.1 Introduction	5
3.2 Well Siting and Construction.....	5
3.3 Handling of Drill Cuttings.....	7
3.4 Soil and Soil Gas Sampling	10
3.4.1 Soil Sampling	10
3.4.2 Soil Gas Sampling	10
3.5 Blower System	10
3.6 Air Monitoring	12
3.7 In-Situ Respiration Test.....	12
3.8 Air Permeability Test.....	14
3.9 Design and Installation of Extended Pilot Test Bioventing System.....	14
4.0 EXCEPTIONS TO PROTOCOL PROCEDURES	14
5.0 BASE SUPPORT REQUIREMENTS	15
6.0 PROJECT SCHEDULE.....	15
7.0 POINTS OF CONTACT	16
8.0 REFERENCES.....	16

LIST OF FIGURES

Figure 2.1 Area Location Map.....3

Figure 2.2 Site Location Map.....4

Figure 3.1 Proposed Vent Well/Vapor Monitoring Point Locations at
the BFSA.....6

Figure 3.2 Central Injection Vent Well Construction Detail.....8

Figure 3.3 Monitoring Point Construction Detail.....9

Figure 3.4 Schematic of Initial Test Phase Blower System.....11

Figure 3.5 Extended Test Area13

PART I

DRAFT BIOVENTING TEST WORK PLAN FOR

BULK FUEL STORAGE AREA

PEASE AFB, NEW HAMPSHIRE

1.0 INTRODUCTION

This test work plan presents the scope of an *in-situ* bioventing pilot test for treatment of fuel contaminated soils within the Bulk Fuel Storage Area (BFSA) at Pease Air Force Base (AFB), New Hampshire. The pilot test has four primary objectives: 1) to assess the potential for supplying oxygen throughout the contaminated soil depth, 2) to determine the rate at which indigenous microorganisms will degrade fuel when stimulated by oxygen rich soil gas, 3) to evaluate the potential for sustaining these rates of biodegradation until fuel contamination is remediated below regulatory standards, and 4) to install bioventing wells in a portion of the site where new construction is planned in order to prevent future soil remediation from disrupting future fuel storage operation.

The first phase of the pilot testing will consist of an initial air permeability and *in-situ* respiration test which will take place in September of 1993. Following the initial test phase, an expanded pilot system will be designed and installed to affect possibly as much as two acres at the BFSA. This system will be installed and a second phase, the extended one-year pilot test, will be conducted to determine the potential for bioventing remediation using natural nutrient levels. Testing will also provide an estimate of cold weather biodegradation rates. If bioventing proves to be feasible at this site, pilot test data may be used to design a full-scale remediation system for the remainder of the BFSA.

The initial test will involve injection at a vent well with a regenerative blower to produce a radius of influence of approximately 40 feet. *In-situ* rates of fuel biodegradation and soil gas permeability will be determined during this short term test. The information gathered during the initial test will be used to design an expanded pilot system involving multiple injection wells and possibly multiple regenerative blowers to supply sufficient air for the larger test area. All extended testing will have to be conducted with regulatory concurrence.

Additional background information on the development and recent success of the bioventing technology is found in the document entitled *Test Plan and Technical Protocol For A Field Treatability Test For Bioventing* (Hinchee, et al. 1992). This protocol document is a supplement to the site-specific work plan, and it will also serve as the primary reference for pilot test vent well designs and detailed test objectives and procedures. Unless otherwise noted, test procedures outlined in the protocol document will be used during the pilot test at the BFSA.

2.0 SITE DESCRIPTION

2.1 Site Location and History

Pease AFB is located in Rockingham County, New Hampshire, between the city of Portsmouth and the towns of Newington and Greenland (Figure 2.1). The main base consists of 4,365 acres comprised of runways and airfield operations, industrial and commercial operations, woodlands and undeveloped lands. The facility was closed as an active military reservation on 31 March 1991. However, the New Hampshire Air National Guard (NHANG) remains active at the airfield. Approximately 1,050 acres of the base property was transferred to the Department of the Interior, U.S. Fish and Wildlife Service, as a wildlife refuge. Another 1,702 acres have been leased to the State of New Hampshire's Pease Development Authority (PDA). The PDA operates a commercial airport and has planned uses for the leased property including commercial and industrial redevelopment.

The Bulk Fuel Storage Area (BFSA) was the main storage area for fuels for past Pease AFB operations. The BFSA encompasses approximately 16 acres and is located at the northeastern end of the base (Figure 2.2). Presently, the BFSA contains two aboveground storage tanks. Two new additional aboveground storage tanks are to be constructed in the BFSA within the next 12 months. An additional goal of the extended pilot testing will be to install bioventing wells in an area where the new tanks will be built so that remediation can begin and continue without disruption to the construction schedule. Five additional underground storage tanks (USTs) were excavated and removed, and one other UST was abandoned in place as it was partially under a building. The BFSA tanks were used for storage of JP-4, JP-7, JPTS, MOGAS, deicing fluid, and diesel fuel. Major spills are reported to have occurred in the BFSA in 1963, 1975, and 1980.

Numerous soil borings and groundwater monitoring wells have been installed at the BFSA, and have indicated significant hydrocarbon contamination of soils above the groundwater table. The hydrocarbon contamination of soils at this site is the target for bioventing treatment.

2.2 Site Geology

Because the bioventing technology is applied to the unsaturated soils, this section will primarily address soils above the shallow aquifer. Soils above the water table at this site consist of three units in descending order:

- Upper sand (5 to 11 feet thick)
- Marine clay (0 to 2 feet thick)
- Glacial till (7 to 13 feet thick)

Bedrock is located at an average depth of 15 to 23 feet below ground surface. Groundwater is encountered at a depth of approximately 10 to 12 feet during the wet months (i.e. January through May) and from 16 to 18 feet in the dryer months (i.e. July through September). Groundwater fluctuations as much as 7.5 feet have

FIGURE 2.1

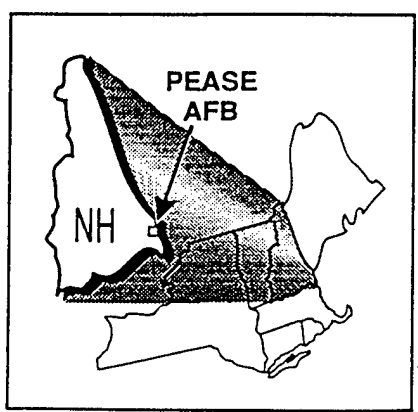
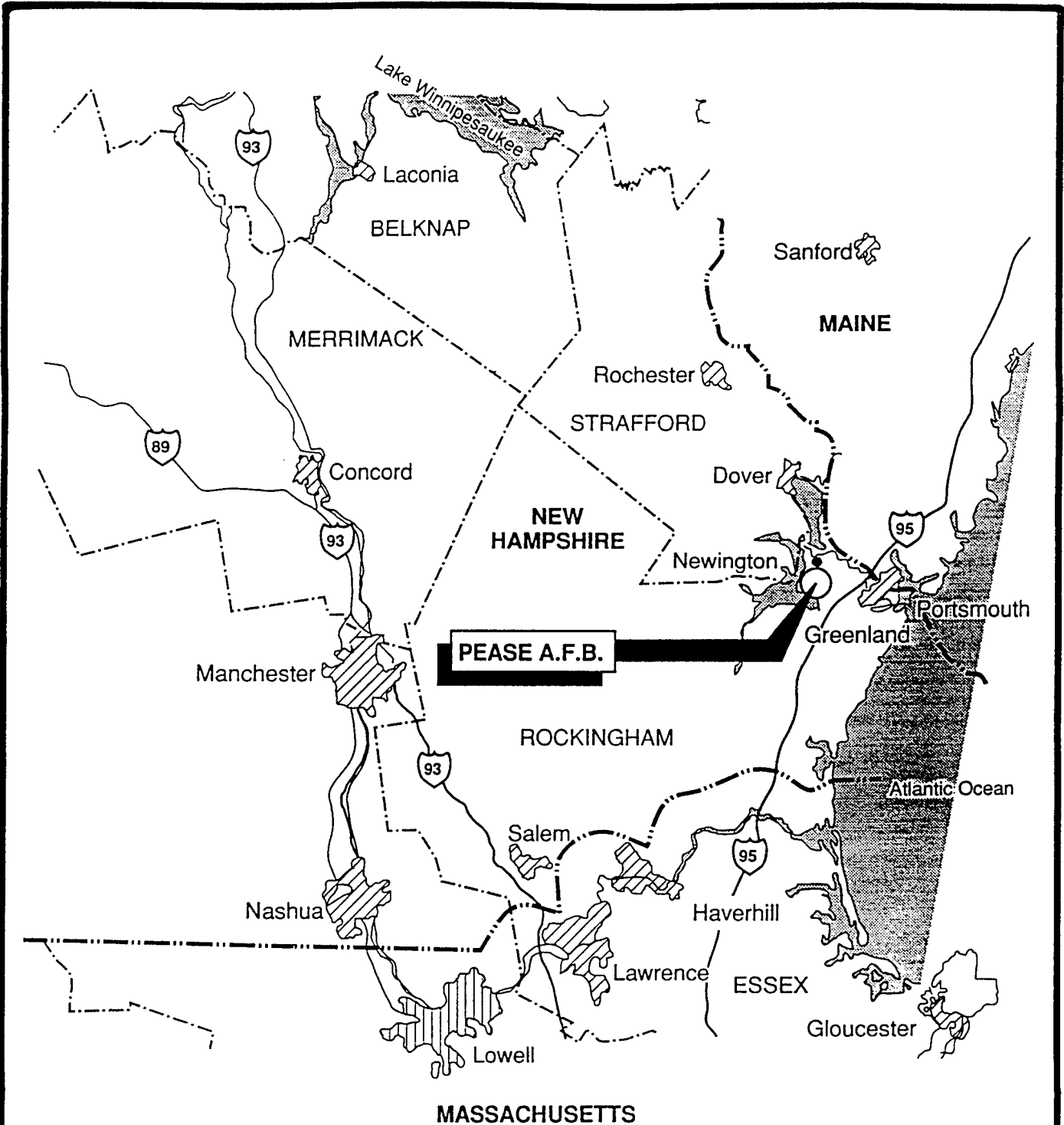

SOURCE: WESTON 1992

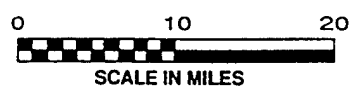

ENGINEERING - SCIENCE

**SITE LOCATION MAP
PEASE AFB
NEW HAMPSHIRE**

SITE PLAN PEASE AFB NEW HAMPSHIRE

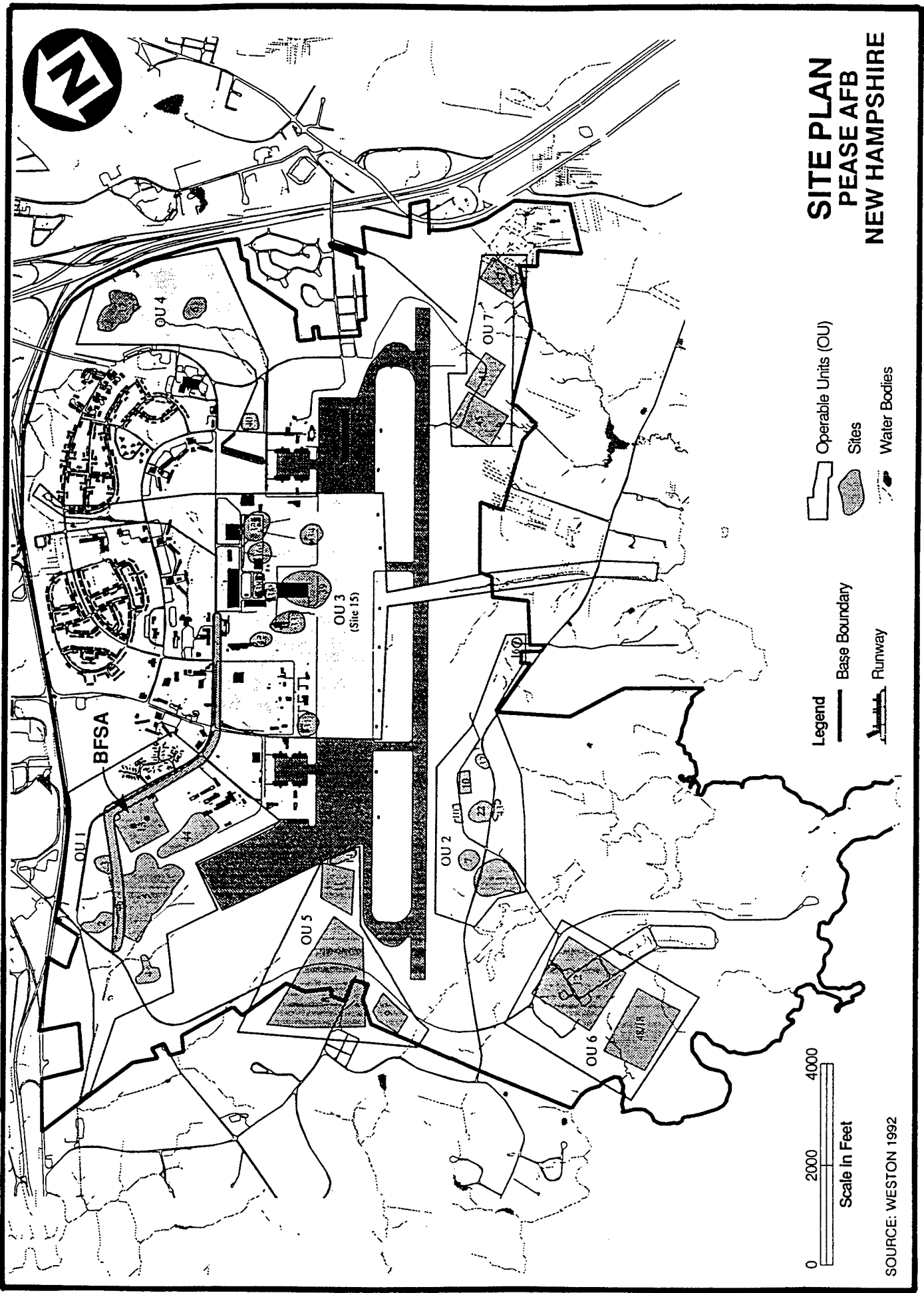

- Legend**
- Operable Units (OU)
 - Base Boundary
 - Runway
 - Sites
 - Water Bodies

0 2000 4000
Scale in Feet

SOURCE: WESTON 1992

been recorded at the BFSA. In general, groundwater flows in a northeasterly direction across the site at a gradient of approximately 0.02 feet per foot (ft/ft).

Although the soils at the BFSA are relatively heterogeneous, good distribution of air flow should be possible across the site as the air injection wells will be screened across as much of the vertical profile as possible. Engineering-Science has completed successful bioventing projects within similar geological deposits and we are confident that oxygen can be distributed in these soils.

2.3 Site Contaminants

The primary contaminants in the BFSA soils are JP-4 fuel residuals which have migrated downward to the water table. Soil samples collected inside the source area and above the water table showed TPH concentrations from non-detectable to 18,000 mg/kg. The volatile organic compounds benzene, toluene, ethylbenzene, and total xylenes (BTEX) were detected in the soils above the water table from non-detectable to 44.3 mg/kg.

3.0 PILOT TEST ACTIVITIES

3.1 Introduction

The purpose of this section is to describe the work that will be performed by Engineering-Science, Inc. (ES) at the BFSA. Activities associated with the initial test phase include siting and construction of a central vent well (VW) and three vapor monitoring points (VMPs); an *in-situ* respiration test; and an air permeability test. Soil and soil gas sampling procedures and the blower configuration that will be used to inject air (oxygen) into contaminated soils are also discussed in this section. In an effort to be as cost effective as possible, a single VW will be completed to the depth of lowest seasonal groundwater at the site. Pilot test activities will be confined to unsaturated soils remediation; no dewatering will take place during the pilot tests. Existing monitoring wells will not be used as primary air injection or extraction wells. However, monitoring wells which have a portion of their screened interval above the water table may be used as VMPs or to measure the composition of background soil gas.

3.2 Well Siting and Construction

A general description of criteria for siting the single central VW and associated VMPs are included in the protocol document. Figure 3.1 illustrates the proposed location of the central VW and VMPs at the BFSA. The final location of the VW may vary slightly from the proposed location if significant fuel contamination is not observed in the boring for the central VW, or if construction restraints indicate that another location may be more desirable. Based on site investigation data and discussions with base personnel, the VW will be located in the southeastern corner of the new BFSA. The area is expected to have an average TPH concentration exceeding 1,000 mg/kg. Soils in this area are expected to be oxygen depleted (< 2%) and increased biological activity should be stimulated by oxygen-rich soil gas ventilation during full-scale operations. Additionally, this area is likely to not be

FIGURE 3.1

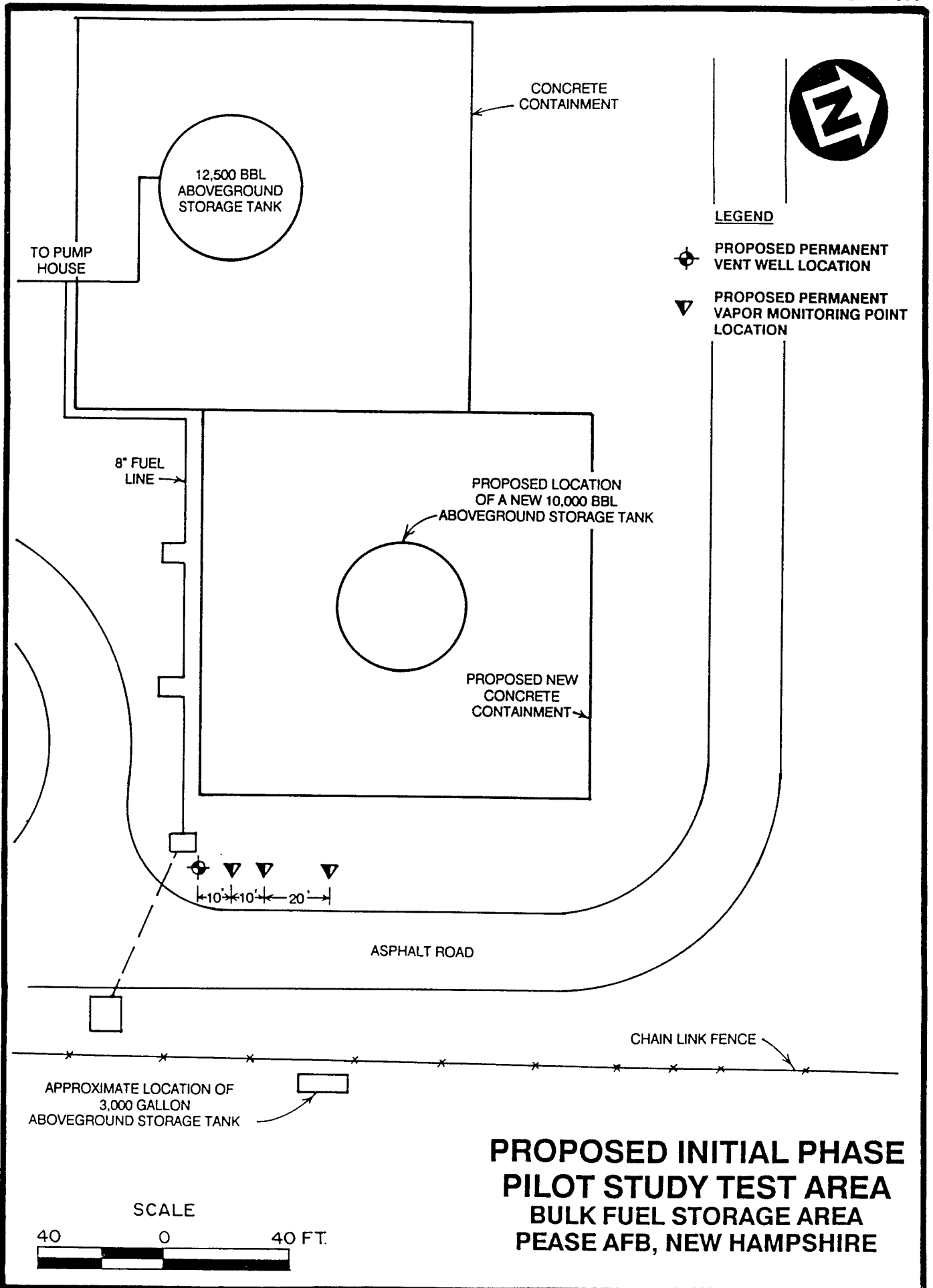

disturbed by future construction, and could be used for permanent monitoring of the bioventing system.

Due to the relatively shallow depth of contamination at this site and the potential for moderate permeability soils, the radius of venting influence around the central air injection well is expected to reach approximately 40 feet. Three VMPs will be located within a 40-foot radius of the central VW. Background monitoring for the site will occur at either an existing uncontaminated well near the BFSAs, or at a background monitoring point which will be installed at an upgradient location south of the BFSAs.

The VW will be constructed of 4-inch diameter Schedule 40 PVC, with a 15 foot interval of 0.04 slotted screen set between 6 and 21 feet bgs. Flush-threaded PVC casing and screen will be used with no organic solvents or glues. The filter pack will be clean, well-rounded silica sand with a 6-9 grain size and will be placed in the annular space of the screened interval. A 3-foot layer of bentonite will be placed directly over the filter pack. The bentonite will consist of granular bentonite and/or pellets placed in 6-inch lifts and hydrated in place with potable water to produce an air tight seal above the screened interval. A complete seal is critical to prevent injected air from short-circuiting to the surface during the bioventing test. Silica sand and cement grout will be placed over the pellets and extend to the ground surface. Figure 3.2 illustrates the proposed central VW construction details for this site.

A typical multi-depth VMP installation for this site is shown in Figure 3.3. Soil gas oxygen and carbon dioxide concentrations will be monitored at depth intervals of approximately 5 to 7 feet bgs, and 12-14 feet bgs at each location. Depending on the depth to groundwater during the VMP installation, a third discrete depth monitoring point may be installed at a depth interval of 17 to 18 feet bgs. If installed, this point may be submerged for part of the year, but may provide valuable information on contamination near the groundwater/vadose zone interface.

Multi-depth monitoring will confirm that the entire soil profile is receiving oxygen and be used to measure fuel biodegradation rates at all depths. The annular space between these two monitoring points will be sealed with bentonite to isolate the monitoring intervals. Additional details on VW and monitoring point construction are found in Section 4 of the protocol document.

3.3 Handling of Drill Cuttings

Drill cuttings from all borings will be screened in the field with a total hydrocarbon vapor analyzer (protocol document, Section 4.5.2). Cuttings above background levels (typically less than 1 part per million) will be transported to the current soil stockpile area within the bermed area at the BFSAs. Cuttings below background will be spread on the ground near the soil borings.

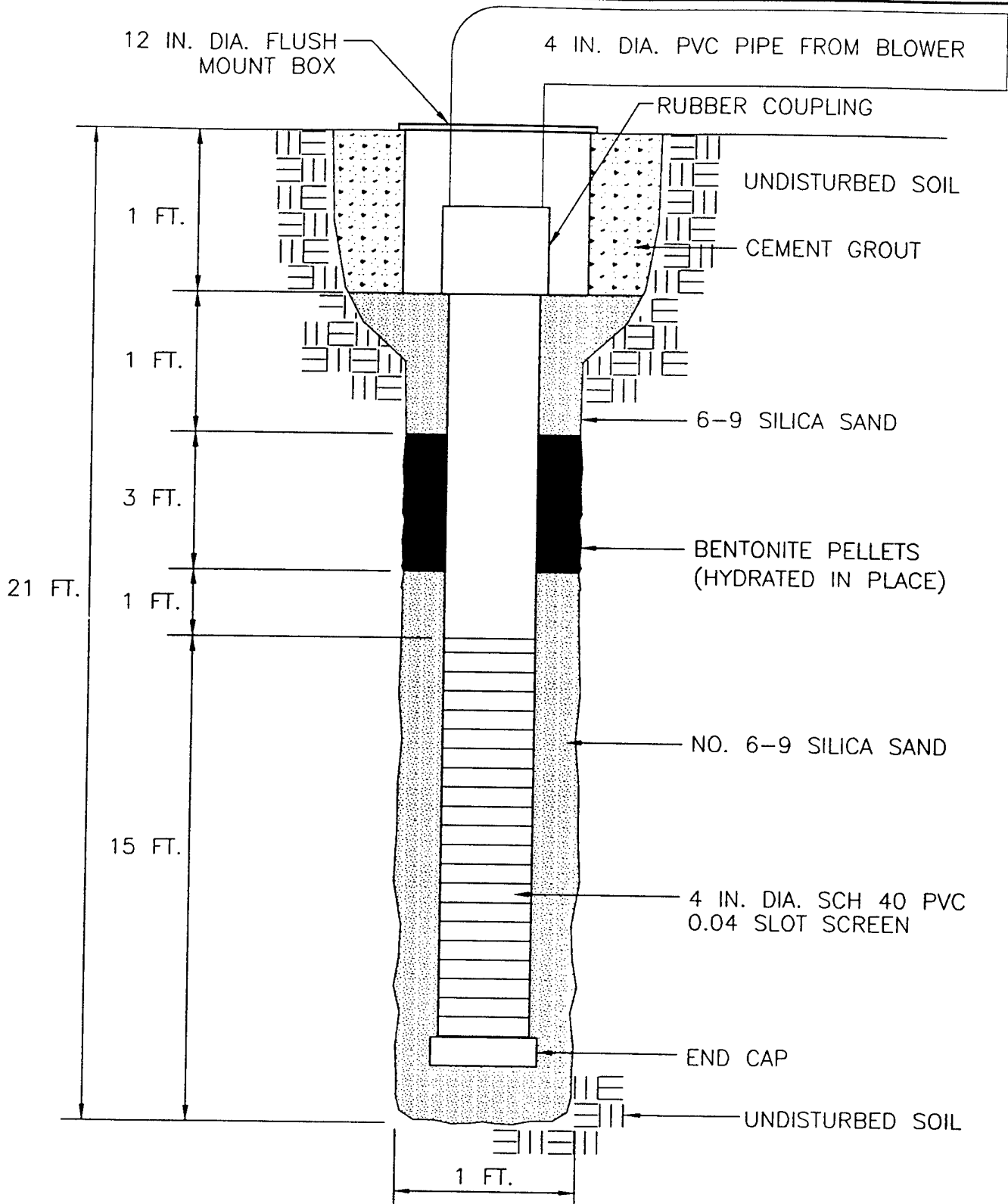

NOT TO SCALE

INJECTION VENTING WELL CONSTRUCTION DETAIL

Pease AFB, New Hampshire

ENGINEERING-SCIENCE, INC.
Syracuse, New York



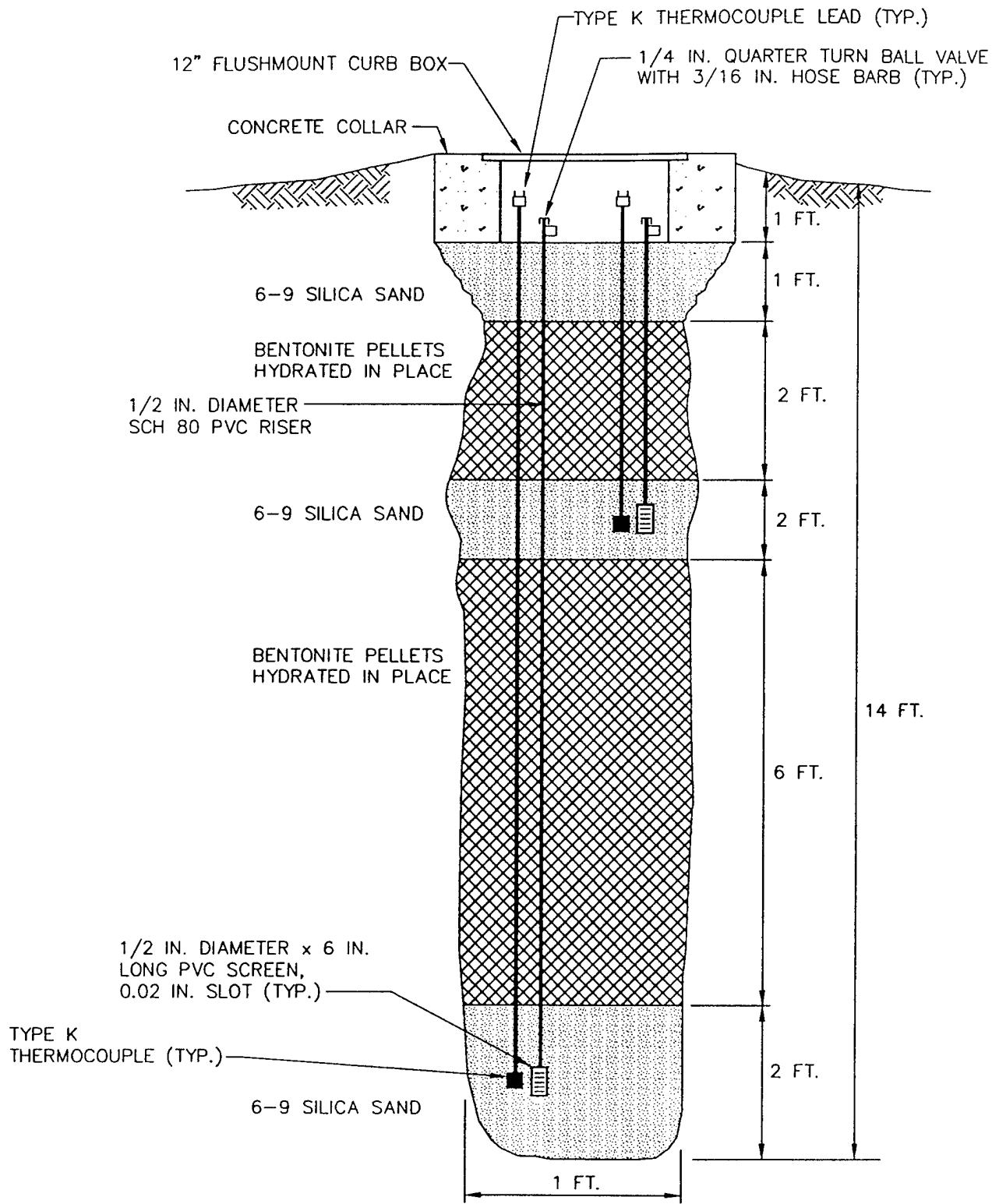

NOT TO SCALE

TYPICAL MONITORING POINT
CONSTRUCTION DETAIL

Pease AFB, New Hampshire

ENGINEERING-SCIENCE, INC.
Syracuse, New York



3.4 Soil and Soil Gas Sampling

3.4.1 Soil Sampling

Three soil samples will be collected from the pilot test area during the installation of the VW and VMPs. One sample will be collected from the most contaminated interval of the central VW boring, and one sample will be collected from the interval of highest apparent contamination in each of the borings for two VMPs at the site. Soil samples will be analyzed for TPH, BTEX, soil moisture, pH, particle sizing, alkalinity, total iron and nutrients.

Samples will be collected using a split-spoon sampler containing brass tube liners. A photoionization detector or total hydrocarbon vapor analyzer will be used to insure that breathing zone levels of volatiles do not exceed 1 ppm during drilling and to screen split spoon samples for intervals of high fuel contamination. Soil samples collected in the brass tubes will be immediately trimmed and aluminum foil and a plastic cap placed over the ends. Soil samples will be labelled following the nomenclature specified in the protocol document (Section 5.5), wrapped in plastic, and placed in an ice chest for shipment. A chain of custody form will be filled out and the ice chest shipped to the Pace laboratory in Novato, California, for analysis. This laboratory has been audited by the U.S. Air Force and meets all quality assurance/quality control and certification requirements for the State of California.

3.4.2 Soil Gas Sampling

A total of three soil gas samples will be collected in SUMMA® canisters in accordance with the *Bioventing Field Sampling Plan* (ES, 1992). The samples will be collected from the VW and from the VMPs closest to and furthest from the VW at the site. These soil gas samples will be used to predict potential air emissions, to determine the reduction in BTEX and total volatile hydrocarbons (TVH) during the 1-year test, and to detect any migration of these vapors from the source area.

Soil gas sample canisters will be placed in a small cooler and packed with foam pellets to prevent excessive movement during shipment. Samples will not be sent on ice to prevent condensation of hydrocarbons. A chain-of-custody form will be filled out, and the cooler will be shipped to the Air Toxics laboratory in Folsom, California for analysis.

3.5 Blower System

A 1.0-HP regenerative blower capable of injecting 30 - 90 scfm will be used to conduct the initial air permeability test at the site. This blower provides a wide range of flow rates and should develop sufficient pressure to move air through moderate permeability soils. A schematic of the initial test phase blower system is presented as Figure 3.4. Air injection will be used to provide oxygen to soil bacteria and to minimize emissions of volatiles to the atmosphere.

An extended pilot test will be performed if initial pilot testing is positive. The extended bioventing test will be initiated following a review of initial test data. The results of the air permeability test will be used to determine the radius of influence that can be achieved by air injection at a single vent well. Using this value, up to 10



ENGINEERING-SCIENCE, INC.
Syracuse, New York

SCHEMATIC OF BLOWER
SYSTEM FOR INITIAL PHASE
PILOT TESTS

PILOT TESTS

BULK FUEL STORAGE AREA
Pease AFB, New Hampshire

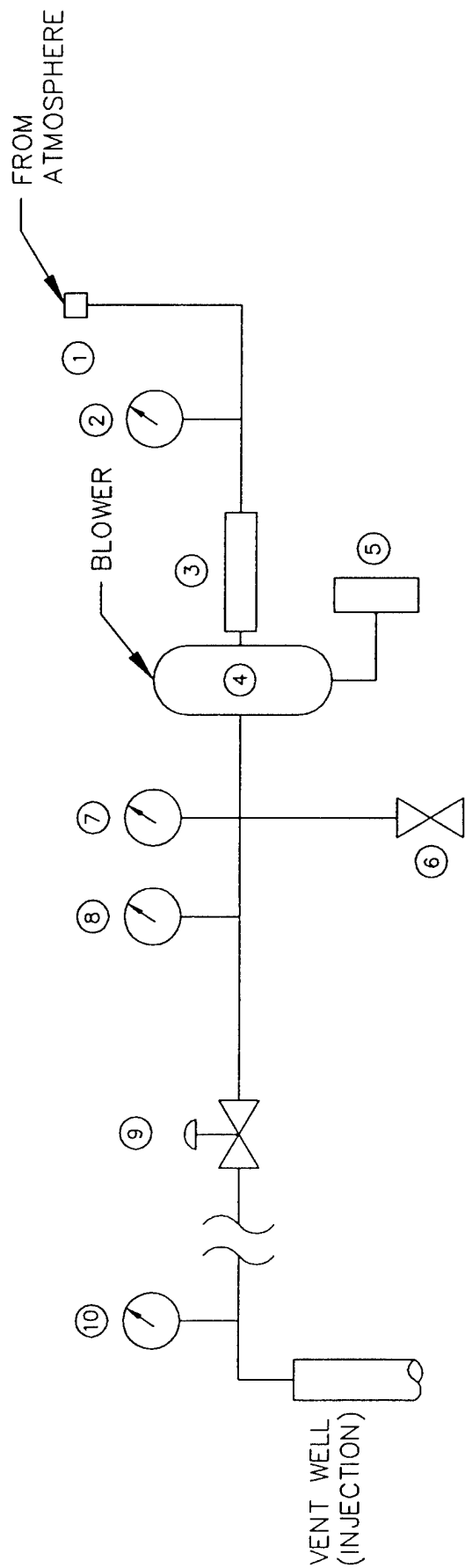

- ① INLET FILTER
- ② VACUUM GAUGE - INCHES OF H2O
- ③ DRIVE MOTOR
2.5 HP / 3450 RPM @ 60 Hz / 230 v / SINGLE PHASE / 15 A /
- ④ BLOWER - GAST R5125
145 SCFM @ 3450 RPM / REGENERATIVE
- ⑤ STARTER
230 v / 27 A / SINGLE PHASE / H1036 HEATER (10.8 A)
- ⑥ AUTOMATIC PRESSURE RELIEF VALVE - SET @ 6 psig
- ⑦ PRESSURE GAUGE (INCHES OF H2O)
- ⑧ THERMOMETER (FAHRENHEIT)
- ⑨ MANUAL PRESSURE RELIEF (BLEED) VALVE - 1 1/2" BALL
- ⑩ AIR VELOCITY MEASUREMENT PORT

additional injection wells may be installed for the extended test phase. These wells will be of similar construction to the initial test phase well, and will be manifolded to one or more regenerative blowers to supply the necessary air to influence the entire extended test area as indicated on Figure 3.5.

3.6 Air Monitoring

The bioventing technique will minimize total emissions of more volatile hydrocarbons to the atmosphere. This is accomplished by reducing air injection rates to supply only the minimum required oxygen to sustain the indigenous microorganisms. By supplying only the required oxygen for biodegradation, volatilization is minimized.

During all activities involving air injection, the air at the ground surface and at the breathing zone within a 20-foot radius of the injection well will be monitored for volatile hydrocarbons by use of a photoionization detector. Air monitoring will be done to ensure safe working conditions and to provide a rough estimate of volatilization losses, if they occur. More intense air monitoring is required during the first eight hours of the air permeability test because the potential for emission of the more volatile hydrocarbons is greatest at that time.

The potential for emissions at this site is minimal because of the age and type of the fuel residuals. The contamination is estimated to be at least 10 years old and to consist mainly of JP-4, which contains a minimal amount of volatile components. Additionally, the site is scheduled for construction of a new above ground fuel storage tank with an impermeable secondary containment system. This new construction will form a seal over the bioventing well system, thus limiting the potential for volatiles emission.

3.7 In-Situ Respiration Test

The objective of the *in-situ* respiration test is to determine the rate at which soil bacteria degrade petroleum hydrocarbons. Respiration tests will be performed at the three VMPs with the highest apparent fuel contamination at the site. Air will be injected into each VMP depth interval containing low levels (<2%) of oxygen. A 20 to 24-hour air injection period will be used to oxygenate local contaminated soil. At the end of the air injection period, the air supply will be cut off, and oxygen and carbon dioxide levels will be monitored for five days or until the oxygen level falls below 5 %, whichever is earlier. The decline in oxygen and increase in carbon dioxide concentrations over time will be used to estimate rates of bacterial degradation of fuel residuals.

Concurrent to the air injection period, a helium tracer will also be injected at the VMPs at a concentration of two to five percent. Helium levels will be monitored along with the oxygen and carbon dioxide levels to ensure that the VMPs do not leak. Additional details on the in-situ respiration test are found in Section 5.7 of the protocol document.

FIGURE 3.5

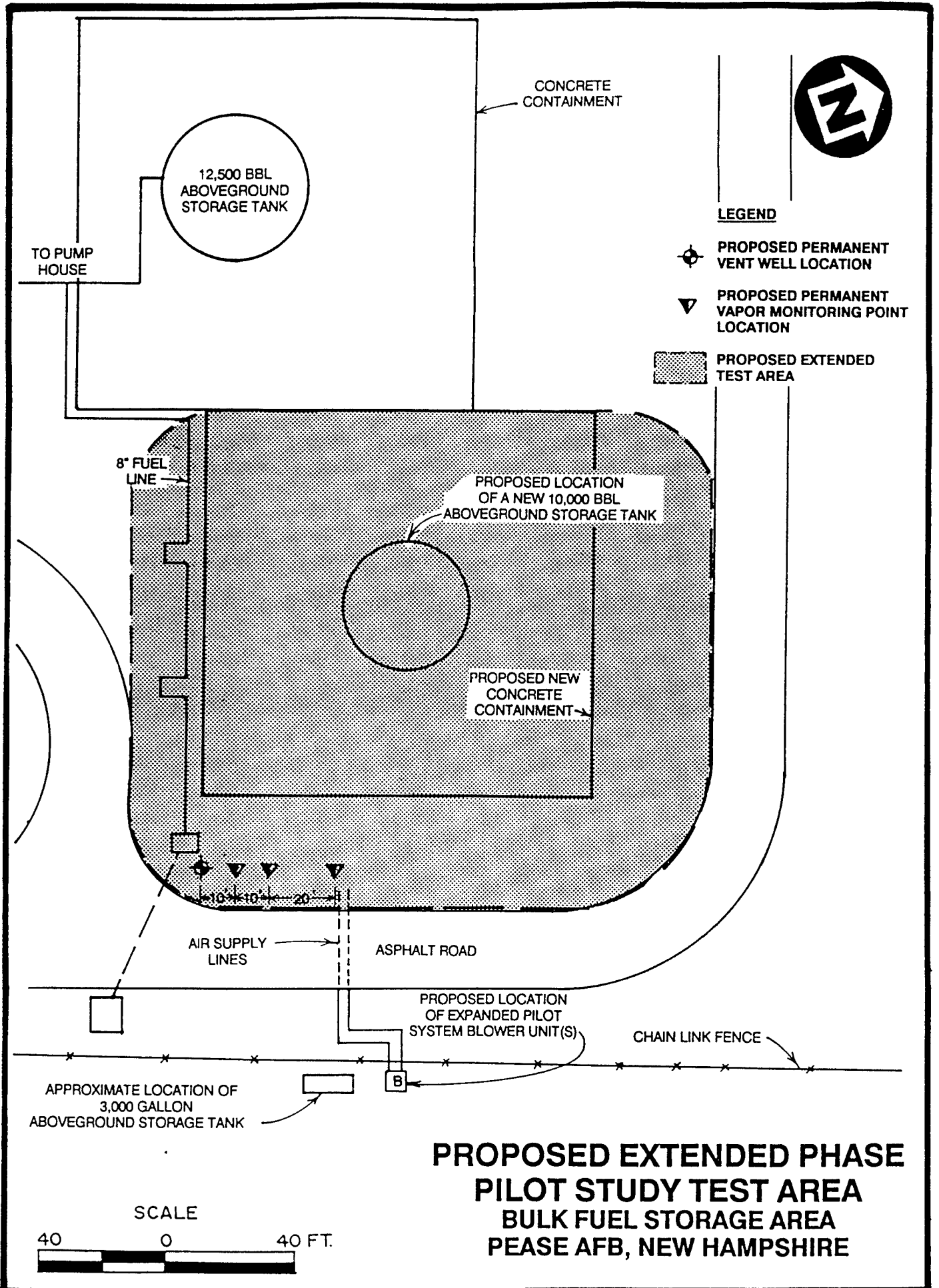

3.8 Air Permeability Test

The objective of the air permeability test is to determine the extent of the subsurface that can be oxygenated using one air injection VW. Air will be injected into the 4-inch-diameter VW using the blower unit, and pressure response will be measured at each VMP with differential pressure gauges to determine the region influenced by the unit. Oxygen will also be monitored in the VMPs to verify that oxygen levels in the soil increase as the result of air injection. One air permeability test lasting approximately 24 hours will be performed.

3.9 Design and Installation of Extended Pilot Test Bioventing System

An extended, 1-year bioventing pilot systems will also be designed and installed at BFSa following the initial test phase. This expanded pilot system will likely consist of multiple air injection vent wells (up to 10 vent wells) and additional soil vapor monitoring points. The vent wells will be manifolded to one or more regenerative blowers. Each vent well will be installed with a air flow control valve and pressure gauge to ensure proper air distribution from the blower system. Construction of additional aboveground fuel storage tanks by the New Hampshire Air National Guard will be scheduled following installation of the extended test system. The vent wells and manifold network will be installed, tested and optimized, then covered with fill to allow for the future construction. If possible, permanent vapor monitoring points will be installed near some of the vent wells to allow for future testing of the system. Complete details of the extended test system will be contained in an Interim Test Report which will be produced following the initial test phase.

The base will be requested to provide a power pole with a 230/460-volt, three-phase, 100-amp breaker box. This service will be sufficient to power one or more large regenerative blowers. Two 115-volt receptacles will also be required. A licensed electrician subcontracted to ES will assist in wiring the blower(s) to line power. The blower(s) will be housed in a prefabricated shed to provide protection from the weather.

The expanded pilot system will be in operation for 24-hours per day for 1 year. Following start-up of the expanded blower system, ES personnel will conduct *in-situ* respiration tests every 3 months to monitor the long-term performance of this bioventing system. Weekly system checks will be performed by Pease AFB personnel. If required, major maintenance of the blower unit(s) may be performed by ES personnel. Detailed blower system information and a maintenance schedule will be included in the operation and maintenance (O&M) manual provided to the base. More detailed information regarding the test procedures can be found in the protocol document.

4.0 EXCEPTIONS TO PROTOCOL PROCEDURES

The procedures that will be used to measure the air permeability of the soil and *in-situ* respiration rates are described in Sections 4 and 5 of the protocol document. No exceptions to this protocol are anticipated.

5.0 BASE SUPPORT REQUIREMENTS

The following base support is needed prior to the arrival of a driller and the ES test team:

- Assistance in obtaining regulatory approval for the pilot test if required.
- Assistance in obtaining a digging permit at each site.
- Provision of any paperwork required to obtain gate passes and security badges for approximately four ES employees and two drillers. Vehicle passes will be needed for two trucks and a drill rig.

During the initial three week pilot test the following base support is needed:

- Twelve square feet of desk space and a telephone in a building located as near to the site as practical.
- The use of a fax machine for transmitting 15 to 20 pages of test results.

Note: A generator will be supplied by ES to provide power to the blower during the initial pilot test.

Prior to and during the one year extended pilot test the following base support is needed:

- A breaker box within 50 feet of the proposed blower enclosure which can supply 230/460-volt, three-phase, 100-amp service for the extended pilot test. If the base can not provide electrical support, please contact Mr. David Brown of ES-Syracuse at (315) 451-9560 immediately.
- Check the blower system at least once a week to ensure that they are operating and to record the air injection pressure. ES will provide a brief training session on this procedure.
- Notify Mr. David Brown, ES-Syracuse, (315) 451-9560; or Lt. Colonel Ross Miller of the AFCEE, (210) 536-4331, if the blower or motor stop working.
- Arrange site access for an ES technician to conduct *in-situ* respiration tests approximately six months and one year after the initial pilot test.

6.0 PROJECT SCHEDULE

The following schedule is contingent upon timely approval of this pilot test work plan.

Event	Date
Draft Test Work Plan to AFCEE	27 August 1993
Base/Regulatory Approval To Proceed	17 September 1993
Begin Initial Phase Test	27 September 1993
Complete Initial Phase Test	8 October 1993

Event	Date
Design Expanded Pilot System	25 October 1993
Install and Test Expanded Pilot System	19 November 1993
Interim Results Report	1 December 1993
Quarterly Respiration Test	March, June, September 1994
Final Respiration Test/Soil Sampling	October 1994

7.0 POINTS OF CONTACT

Mr. Art Ditto
AFBDA Operating Location A
61 International Drive, Bldg. 43
Pease AFB, New Hampshire 03803-0157

Lt. Colonel Ross Miller
AFCEE/EST
Brooks AFB, Texas 78235-5000
(210) 536-4331

Mr. David Brown
Engineering-Science, Inc
290 Elwood Davis Road, Suite 312
Liverpool, New York 13088
(315) 451-9560 Fax.(315) 451-9570

8.0 REFERENCES

- Roy F. Weston, Inc. 1991. *Installation Restoration Program Stage 4 Work Plan for Pease Air Force Base, New Hampshire 03801*. West Chester, Pennsylvania. January.
- Roy F. Weston, Inc. 1993. *Pease Air Force Base Underground Storage Tank Program Phase III: Site Investigation Report, Volume I: Site Investigation Introduction*. West Chester, Pennsylvania. August.
- Engineering-Science, Inc. 1992. *Project Management Plan for AFCEE Bioventing, Appendix D, Field Sampling Plan*. Denver, Colorado. April.
- Hinchee, R.E., S.K. Ong, R.N. Miller, D.C. Downey, R. Frandt. 1992. *Test Plan and Technical Protocol for a Field Treatability Test for Bioventing*. Columbus, Ohio. January.

PART II

**DRAFT INTERIM TEST RESULTS REPORT FOR
BULK FUEL STORAGE AREA
PEASE AFB, NEW HAMPSHIRE**

Prepared for

**AIR FORCE CENTER FOR ENVIRONMENTAL EXCELLENCE
BROOKS AFB, TEXAS**

and

**AFBDA OPERATING LOCATION A
PEASE AIR FORCE BASE, NEW HAMPSHIRE**

by

**Engineering-Science, Inc
290 Elwood Davis Road
Liverpool, New York**

January 1994

TABLE OF CONTENTS

1.0 Bulk Fuel Storage Area	1
1.1 Pilot Test Design and Construction.....	1
1.2 Vent Well Construction.....	1
1.3 Soil Vapor Monitoring Points.....	1
1.4 Blower Unit Installation	5
2.0 Pilot Test Soil And Soil Gas Sampling Results	5
2.1 Soil and Soil Gas Sampling Results.....	5
2.2 Exceptions to Test Protocol Document Procedures	8
2.3 Field QA/QC Results	8
3.0 Pilot Test Results	8
3.1 Initial Soil Gas Chemistry	8
3.2 Air Permeability.....	11
3.3 Oxygen Influence	11
3.4 In-Situ Respiration Rates.....	11
3.5 Potential Air Emissions	17
4.0 Recommendations	17
5.0 References.....	18

LIST OF FIGURES

Figure 1.1 Pilot Study Test Area 2
Figure 1.2 Typical Geologic Profile 3
Figure 1.3 Injection Venting Well Construction Detail 4
Figure 1.4 Typical Monitoring Point Construction Detail 6
Figure 1.5 Blower Schematic 7
Figure 3.1 MPB-S Oxygen Utilization Rate 14
Figure 3.2 MPC-D Oxygen Utilization Rate 15

LIST OF TABLES

Table 2.1 Soil and Soil Gas Analytical Results 9
Table 3.1 Initial Soil Gas Chemistry 10
Table 3.2 Maximum Pressure Response Air Permeability Test 12
Table 3.3 Oxygen Influence During Air Injection 13
Table 3.4 Summary of Oxygen Utilization Rates 16

PART II

DRAFT INTERIM TEST RESULTS REPORTS FOR

BULK FUEL STORAGE AREA

PEASE AFB, NEW HAMPSHIRE

An initial bioventing pilot test was performed at the Bulk Fuel Storage Area (BFSA) at Pease Air Force Base (AFB), New Hampshire during the period of 27 September 1993 to 5 December 1993. The purpose of this Part II report is to describe the results of the initial pilot tests and to make specific recommendations for extended testing to determine the long-term impact of bioventing to remediate site contaminants. Descriptions of the history, geology, and site contaminants are contained in Part I, the Test Work Plan.

1.0 BULK FUEL STORAGE AREA

1.1 Pilot Test Design and Construction

In accordance with the Test Work Plan, one vertical air injection vent well (VW) and three multiple-depth soil vapor monitoring points (VMPs) were installed the week of 27 September, 1993. A 5-horsepower rotary vane air compressor was installed at the VW to provide the necessary air for the first phase of extended bioventing test. Figure 1.1 depicts the locations of the VW, VMPs and compressor at the BFSA site. The hydrogeology of the BFSA is depicted on the cross-section in Figure 1.2. The following sections describe in more detail the final design and installation of the bioventing system.

1.2 Vent Well Construction

The VW was installed on 29 September, 1993 in an area of documented high TPH contamination. The VW was constructed of 4-inch diameter Schedule 40 PVC with a slot size of 0.04 inches. The total depth of the VW was 15 feet below ground surface (bgs), with a screened interval from 5 to 15 feet bgs. The annular space between the well casing and the borehole was filled with 6-9 silica sand from the bottom of the boring to approximately four and a half feet bgs. Granular bentonite was placed above the sand pack from four and a half feet bgs to two feet bgs and hydrated in place with potable water. A one-foot layer of 6-9 silica sand was placed over the bentonite layer. The VW was finished with a one foot layer of cement/bentonite grout and a 12-inch flushmount protective well cover. The well cover was cemented in place with the cement/bentonite grout. A detail of the VW construction is presented on Figure 1.3.

1.3 Soil Vapor Monitoring Points

Three soil vapor monitoring points (VMPs) were installed at 10, 20 and 30 feet radially away from the air injection vent well. Each VMP was constructed to

FIGURE 1.1

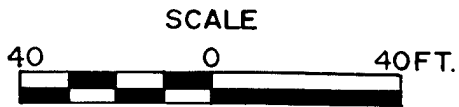

ROAD

7352

LEGEND

- ⊕ EXISTING MONITORING WELL
- ⊕ VENT WELL LOCATION
- ▽ VAPOR MONITORING POINT LOCATION
- EXTENDED TEST BLOWER LOCATION

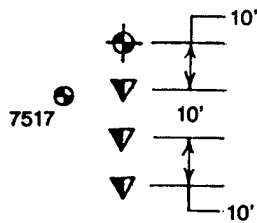

7517

ABOVEGROUND STORAGE TANK

BERM

FORMER LOCATION OF ABOVE GROUND STORAGE TANK

7350

7546

7369

**PILOT STUDY TEST AREA
BULK FUEL STORAGE AREA
PEASE AFB, NEW HAMPSHIRE**

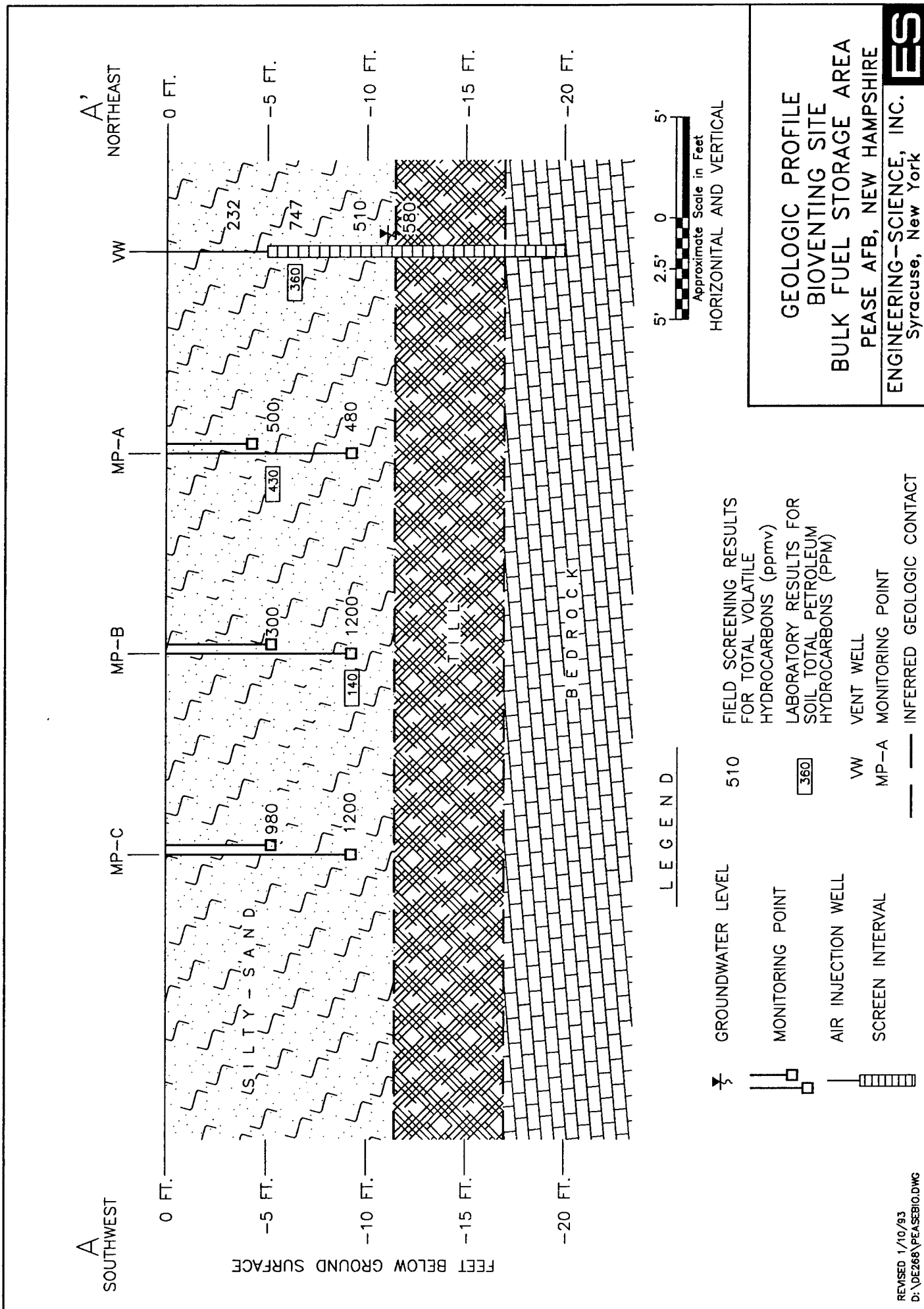

GEOLOGIC PROFILE
BIOVENTING SITE
BULK FUEL STORAGE AREA
 PEASE AFB, NEW HAMPSHIRE
 ENGINEERING-SCIENCE, INC.
 Syracuse, New York



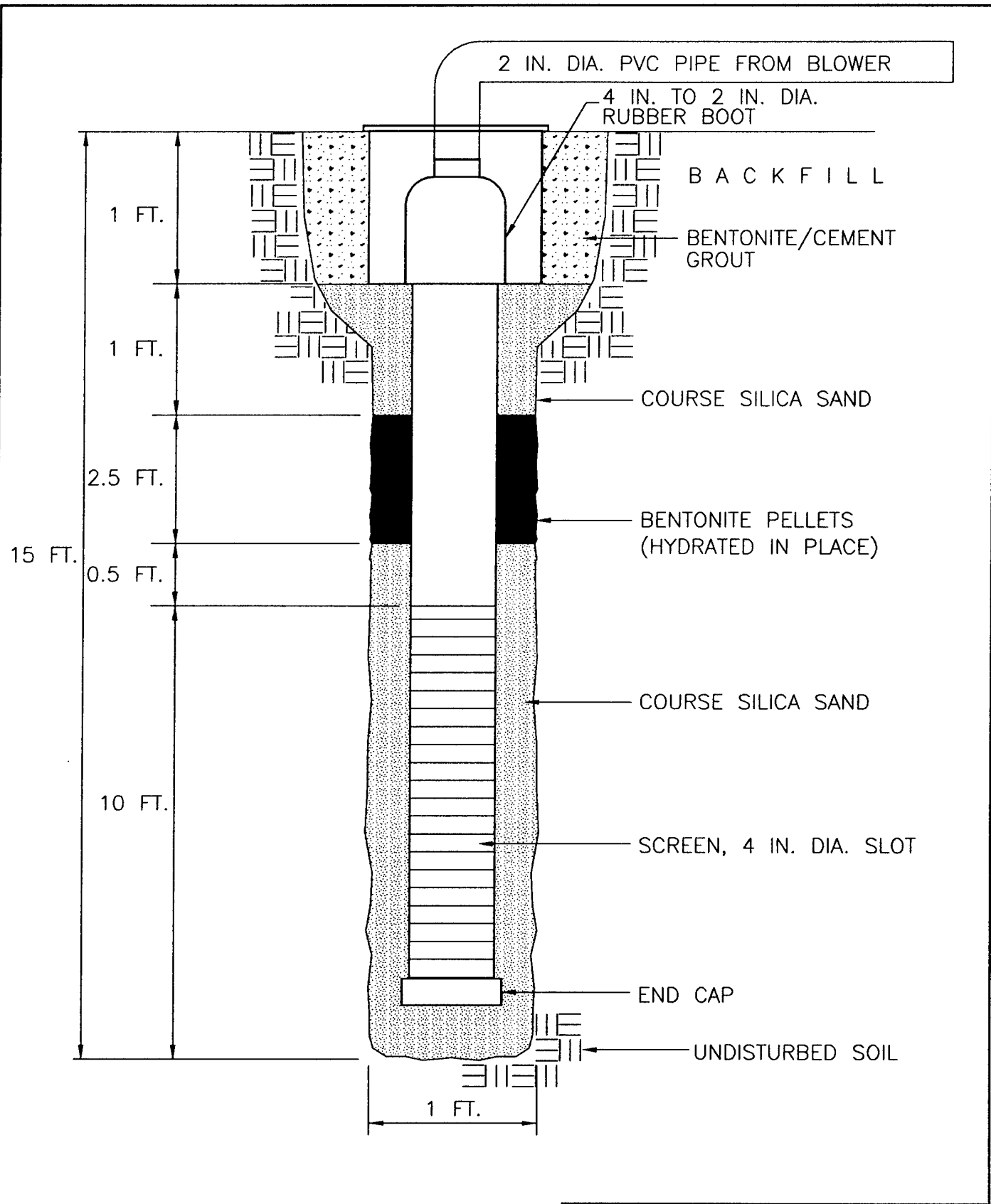

NOT TO SCALE

INJECTION VENTING WELL
CONSTRUCTION DETAIL

Pease AFB, New Hampshire

ENGINEERING-SCIENCE, INC.
Syracuse, New York



provide multiple depth soil gas monitoring with two discrete sample points at 9.5 and 3.5 feet bgs in MPA and at 9.5 and 5.0 feet bgs in MPB and MPC. Each discrete point was constructed of a six-inch long piece of 1/2-inch diameter Schedule 40 PVC well screen with 0.02 slot size. The riser of each discrete point was constructed of 1/2-inch Schedule 80 PVC, which extended to approximately six inches bgs.

Clean 6-9 silica sand was placed around each discrete point to provide a filter pack between the borehole wall and the point. Granular bentonite was placed both below and above each discrete point to provide an air tight seal between the points. The bentonite was placed in 12-inch lifts and hydrated in place to assure the proper seal. The top of each discrete point riser was fitted with a 1/4-inch quarter turn ball valve and 3/16-inch hose barb to allow for connection of appropriate monitoring instruments.

Additionally, Type K thermocouples with mini connectors were installed at the 9.5 feet and 3.5 feet bgs discrete monitoring points in the VMP closest to the VW (MPA). These thermocouples will be used to measure the soil temperature profile at the site. The top of each VMP was completed with a 12-inch flush mounted protective well cover set in a concrete base. Figure 1.4 shows the construction of the soil vapor monitoring points.

1.4 Blower Unit Installation

A 5-horsepower GAST® rotary vane air compressor unit was installed at the BFSAsite for extended pilot test. The compressor was installed in a weather resistant enclosure and electrically wired for permanent 240-volt, 30-amp service. Air from the compressor is injected into the vent well via a one inch line connected to the compressor's exhaust port. A diagram of the compressor unit and installation is presented on Figure 1.5.

Prior to departing the site, the ES engineer provided an operations and maintenance briefing, O&M checklist, and compressor maintenance manual to the base point of contact. A copy of the O&M checklist is provided in Appendix A.

2.0 PILOT TEST SOIL AND SOIL GAS SAMPLING RESULTS

2.1 Soil and Soil Gas Sampling Results

Soils at the BFSAsite consist of an upper sand (5 to 11 feet thick), a marine clay (0 to 2 feet thick), and a glacial till (7 to 13 feet thick). Bedrock was located at an average depth of 15 to 23 feet bgs. Groundwater was encountered at approximately 10 to 12 feet bgs during the wet months (i.e. January through May) and at approximately 16 to 18 feet bgs during the dryer months (i.e. July through September). Groundwater fluctuations as much as 7.5 feet have been recorded at the BFSAsite.

Hydrocarbon contamination at the site appears to extend from the ground surface to the groundwater table. Contaminated soils collected by split spoons during the VW and VMP installations were identified based on visual appearance,

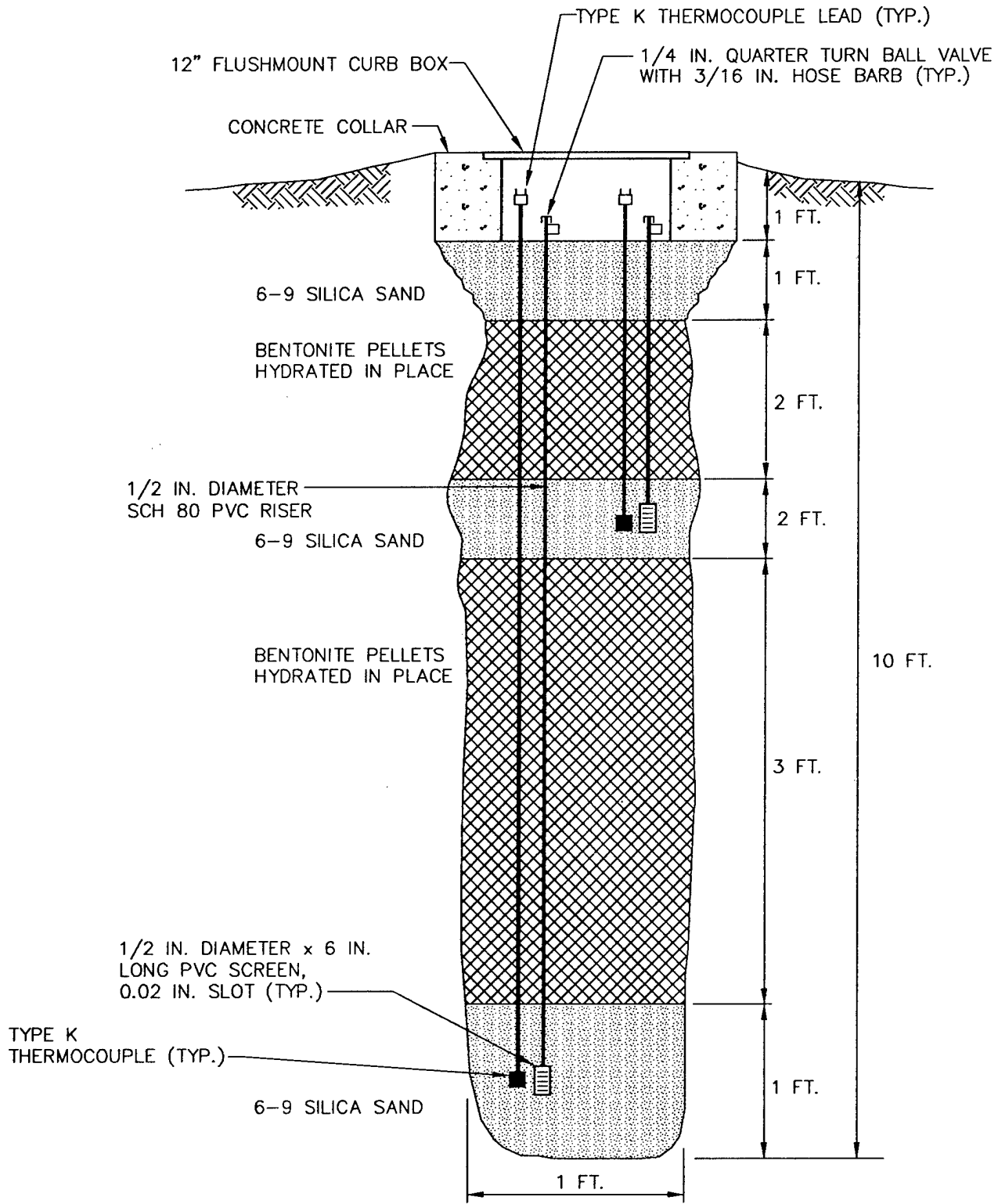

NOT TO SCALE

TYPICAL MONITORING POINT
CONSTRUCTION DETAIL

Pease AFB, New Hampshire

ENGINEERING-SCIENCE, INC.
Syracuse, New York



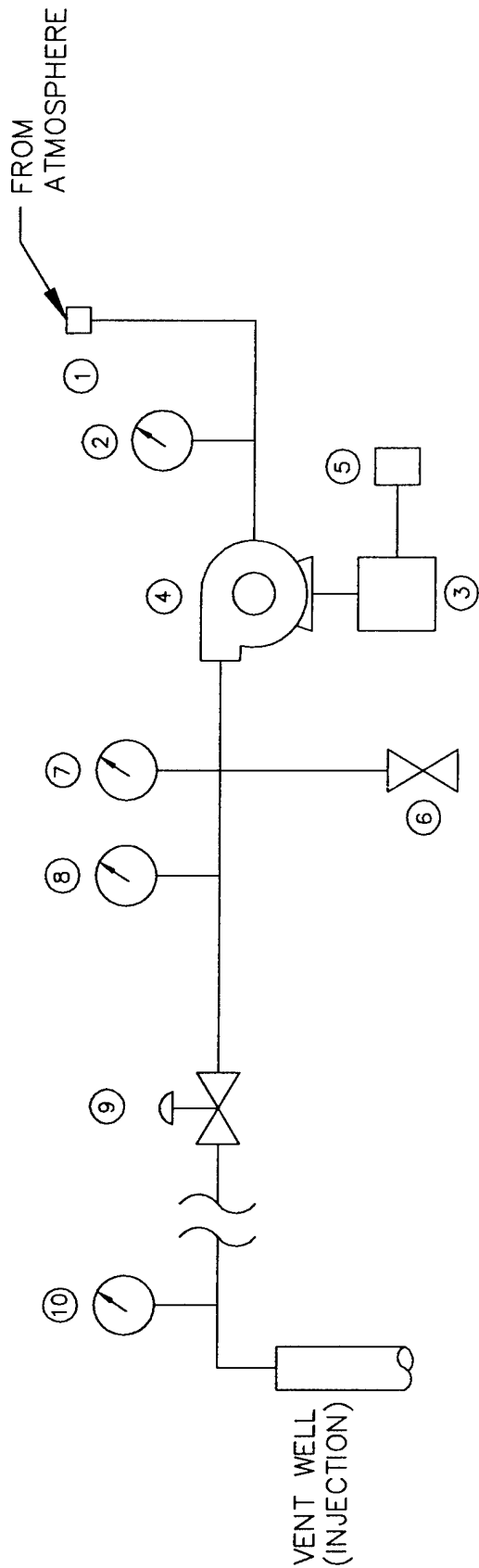

- ① INLET FILTER
- ② VACUUM GAUGE - (PSI)
- ③ DRIVE MOTOR
5.0 HP / 1725 RPM @ 60 Hz / 230 v / SINGLE PHASE / 27A
- ④ COMPRESSOR - GAST 6066
40 SCFM @ 10 PSI / ROTARY VANE
- ⑤ STARTER 230 v / 30 A / SINGLE PHASE
- ⑥ AUTOMATIC PRESSURE RELIEF VALVE - SET @ 15 psig
- ⑦ PRESSURE GAUGE (PSI)
- ⑧ THERMOMETER (FAHRENHEIT)
- ⑨ MANUAL PRESSURE RELIEF (BLEED) VALVE - 1 1/2" BALL
- ⑩ AIR VELOCITY MEASUREMENT PORT

FIGURE 1.5
SCHEMATIC OF COMPRESSOR
SYSTEM FOR AIR INJECTION
(BULK FUEL STORAGE AREA)
PEASE AFB, NEW HAMPSHIRE

ENGINEERING—SCIENCE, INC.
Syracuse, New York

odor and photoionization detector (PID) screening. PID readings ranged from 0 parts per million (ppm) to 1,200 ppm.

Soil samples for laboratory analysis were collected in stainless steel split spoons during the VW and VMP installations. Procedures for soil sample collection specified in the Protocol Document (Hinchee, et. al., 1992) were followed for all sample collections. Samples were collected from the 4-6 feet interval from the VW, from the 3-5 feet interval in MPA, and from the 8-10 feet interval in MPB. A soil sample was also collected from the 4-6 feet interval in a soil boring SB-1 for background TKN analysis. All split spoon samples were field screened for VOCs by use of the PID to determine the presence of hydrocarbon contamination and to select samples for laboratory analysis.

Soil gas samples were collected immediately following the air permeability test in laboratory provided, evacuated SUMMA® canisters. Soil gas samples were collected from the VW, the 9.5 feet bgs discrete monitoring point at MPA, and from the 9.5 feet bgs discrete monitoring point in MPC. All soil gas samples were collected following procedures in the Protocol Document.

The soil samples for laboratory analysis were placed on ice and shipped via Federal Express® to the PACE Inc., Laboratory in Huntington Beach, CA. Each soil sample was analyzed for total recoverable petroleum hydrocarbons (TRPH); benzene, toluene, ethylbenzene, and xylenes (BTEX); iron; alkalinity; total Kjeldahl nitrogen (TKN); pH; phosphates; percent moisture; and grain size distribution. Soil gas samples were placed in a shipping box (without ice), and shipped via Federal Express® to Air Toxics, Inc., in Folsom, CA for total volatile hydrocarbon (TVH) and BTEX analysis. The results of the soils and soil gas samples are presented in Table 2.1.

2.2 Exceptions to Test Protocol Document Procedures

No exceptions to the Test Protocol Document procedures were conducted during the initial pilot test at the BFSa site.

2.3 Field QA/QC Results

Field quality assurance/quality control (QA/QC) samples were not collected or required at this site because the five percent collection requirement for QA/QC duplicate samples has been met at other AFCEE bioventing test sites.

3.0 PILOT TEST RESULTS

3.1 Initial Soil Gas Chemistry

Prior to initiating any air injection, soil gas in the VW and all VMPs was monitored for TVH, oxygen, and carbon dioxide. The VW and VMPs were purged to remove stale soil gas prior to monitoring. Soil gas monitoring was accomplished using portable gas analyzers as described in the Protocol Document. The results of the initial monitoring are presented in Table 3.1.

As shown in Table 3.1, the VW and all VMPs exhibited depleted oxygen levels (4 % to 8 %), elevated carbon dioxide readings (0.3 % to 7 %), and TVH readings

TABLE 2.1
SOIL AND SOIL GAS LABORATORY ANALYTICAL RESULTS
BULK FUEL STORAGE AREA
Pease AFB, New Hampshire

Analyte (Units) ^a	Sample Location – Depth (feet below ground surface)		
	PE-VW-1-15	PE-MPA-D	PE-MPC-D
<u>Soil Gas Hydrocarbons</u>			
TPH (ppmv)	9000	84000	51000
Benzene (ppmv)	7.1	250	94
Toluene (ppmv)	ND	27	ND
Ethylbenzene (ppmv)	4.3	34	16
Xylenes (ppmv)	8.1	38	21
<u>Soil Hydrocarbons</u>			
TRPH (mg/kg)	360	430	140
Benzene (mg/kg)	ND	0.41	ND
Toluene (mg/kg)	ND	2.2	0.86
Ethylbenzene (mg/kg)	6.4	7.4	1.8
Xylenes (mg/kg)	17	24	4.4
<u>Soil Inorganics</u>			
Iron (mg/kg)	20000	21700	21200
Alkalinity (mg/kg as CaCO ₃)	67	140	220
pH (units)	6.4	6.8	6.7
TKN (mg/kg)	140	160	270
Phosphates (mg/kg)	800	710	670
<u>Soil Physical Parameters</u>			
Soil Temperature (°F @ MPA-S & MPA-D)	(59.5 & 57.0)		
Moisture (% wt.)	13	13	11
Gravel (%)	2.8	3	8.8
Sand (%)	27.9	30.9	31.3
Silt (%)	50.3	43.1	38.9
Clay (%)	19	22.9	23.2

^a TRPH = total recoverable petroleum hydrocarbons; TPH = total petroleum hydrocarbons; mg/kg = milligrams per kilogram; ppmv = parts per million by volume; CaCO₃ = calcium carbonate; TKN = total kjeldahl nitrogen.

ND Not detected.

NS Not sampled.

**TABLE 3.1
INITIAL SOIL GAS CHEMISTRY
BULK FUEL STORAGE AREA
Pease AFB, New Hampshire**

MP Depth (ft)	O ₂ (%)	CO ₂ (%)	TVH (ppm)
PE-VW	6.0	7.0	20000+
PE-MPA-D	8	0.5	NS
PE-MPA-S	5	4	16000
PE-MPB-D	4	NS	NS
PE-MPB-S	5	0.3	20000+
PE-MPC-D	4	0.8	20000+
PE-MPC-S	NS	NS	NS

NS: Sample could not be collected due to a flooded monitoring point screen

ranging from 16,000 ppm to greater than 20,000 ppm. Due to difficulties in sampling in tight soils, the oxygen values may have been increased by atmospheric air intrusion during sampling events. These readings suggest that the indigenous microorganisms have depleted much of the naturally available oxygen supply and indicate the presence of significant biological activity.

3.2 Air Permeability

An air permeability test was conducted according to the Protocol Document procedures on 28 October 1993. Air was injected into the VW for four hours at a rate of approximately 2 cubic feet per minute (cfm) and an average pressure of 180 inches of water. Steady-state pressure levels were not achieved. Table 3.2 provides the maximum pressures at each discrete monitoring point. Based on this data, the site soils have an air permeability of 1.2 to 9.8 darcy units. These values are not typical of such low permeability soils as were found at the site.

3.3 Oxygen Influence

Due to the low permeability soils found at the site during the 28 October 1993 permeability test, a second air injection test was conducted on 5 December 1993 to determine oxygen influence at the site. A commercial air compressor was used to inject 30 SCFM atmospheric air into the VW at a pressure of 20 psig.

Table 3.3 shows the increases in soil gas oxygen that resulted from the 5 December air injection test at the BFSa. The depth and radius of oxygen influence in the subsurface resulting from air injection into the central VW is the primary design parameter for bioventing systems. Optimization of full-scale and multiple VW systems require pilot testing to determine the volume of soil that can be oxygenated at a given flow rate and vent well screen configuration. Oxygen increases were noted at both monitoring depths at MPA, which is at a distance of 10 feet from the vent well. The long-term radius of oxygen influence is expected to exceed 10 feet as site soils begin to dry out under the influence of the injected air. ES intends to conduct additional monitoring on this site after one month of air injection to better define the radius of oxygen influence.

3.4 In-Situ Respiration Rates

In-situ respiration tests were performed at monitoring point MPB at a depth of 5.0 feet bgs and at MPC at a depth of 9.5 feet bgs. The points were chosen based on their low oxygen readings (4 to 5 %) and high TVH readings (greater than 20,000 ppm). A 4.2 percent helium in air mixture was injected into each of the two discrete monitoring points for 21.5 hours during the initial part of the in-situ respiration test. Oxygen, carbon dioxide, TVH, and helium concentrations were then measured in the soil gas at each discrete monitoring point. These readings were collected for approximately 4.75 hours following cessation of the helium/air injection period. The measured oxygen losses were then used to calculate biological oxygen utilization rates. The results of the in-situ respiration testing for the MPB and MPC points are presented in Figures 3.1 and 3.2, and Table 3.4 provides a summary of the calculated oxygen utilization rates.

TABLE 3.2
MAXIMUM PRESSURE RESPONSE
AIR PERMEABILITY TEST
BULK FUEL STORAGE AREA
Pease AFB, New Hampshire

	Distance from injection well (PE-VW)					
	10' (MPA)		20' (MPB)		30' (MPC)	
Depth (feet)	3.5	9.5	5	9.5	5	9.5
Time (minutes)	220	220	220	75	220	120
Max Pressure (inches H ₂ O)	3.8	13.4	7.6	0.91	9.1	6.3

TABLE 3.3
INFLUENCE OF AIR INJECTION AT VENT WELL
ON MONITORING POINT OXYGEN LEVELS
BULK FUEL STORAGE AREA
Pease AFB, New Hampshire

MP	Distance From VW (ft)	Depth (ft)	Initial O ₂ (%)	Final O ₂ (%) Permeability Test
PE-MPA-S	10	3.5	5	20.7
PE-MPA-D	10	9.5	8	19.8
PE-MPB-S	20	5	5	NS
PE-MPB-D	20	9.5	4	NS
PE-MPC-S	40	5	NS	NS
PE-MPC-D	40	9.5	4	NS

NS: Sample could not be collected due to a flooded monitoring point screen.

Respiration Test
 Oxygen and Helium Concentrations
 Bulk Fuel Storage Area, MPB-S
 Pease AFB, New Hampshire

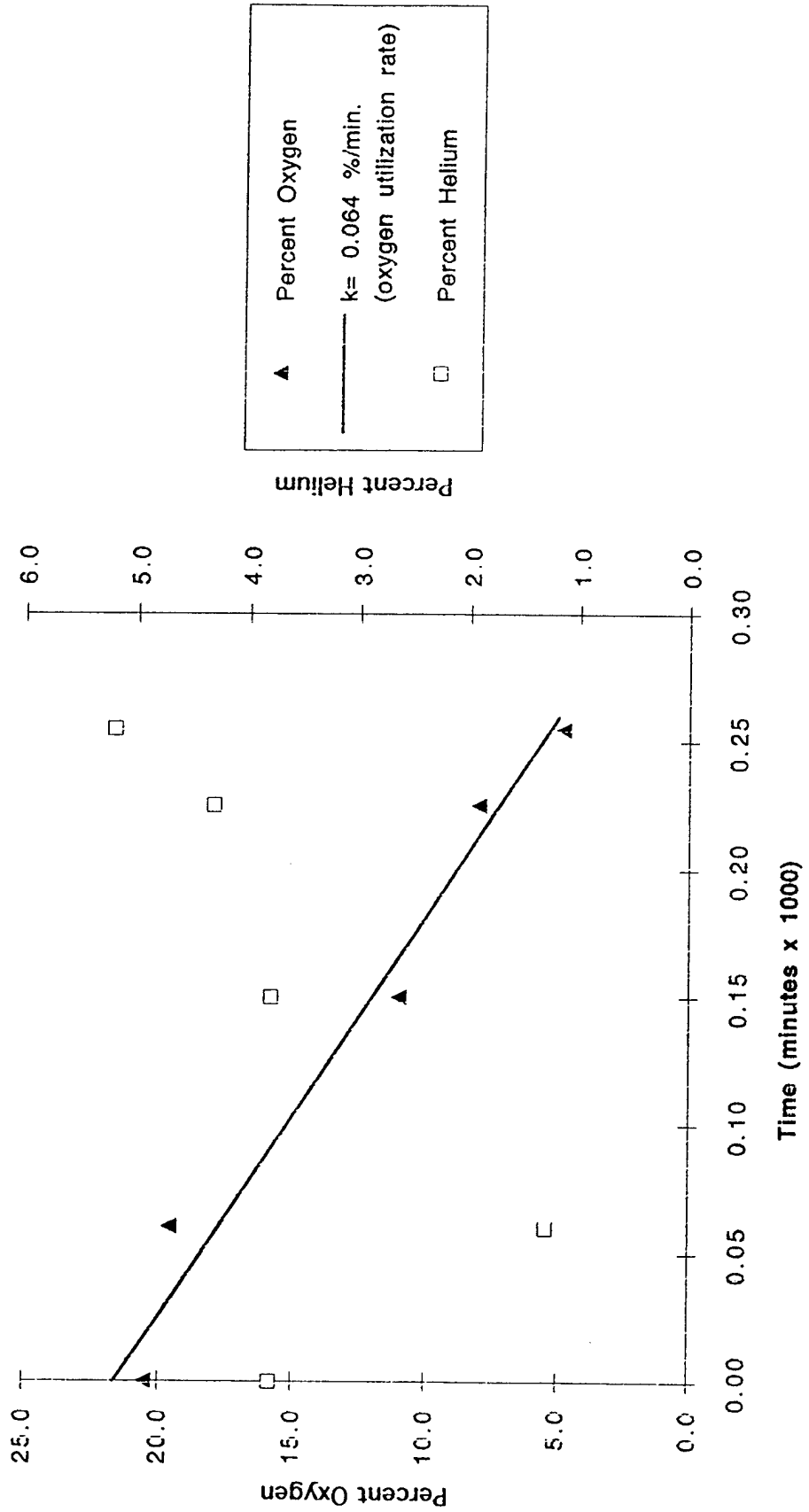

Figure 3.1

Respiration Test
 Oxygen and Helium Concentrations
 Bulk Fuel Storage Area, MPC-D
 Pease AFB, New Hampshire

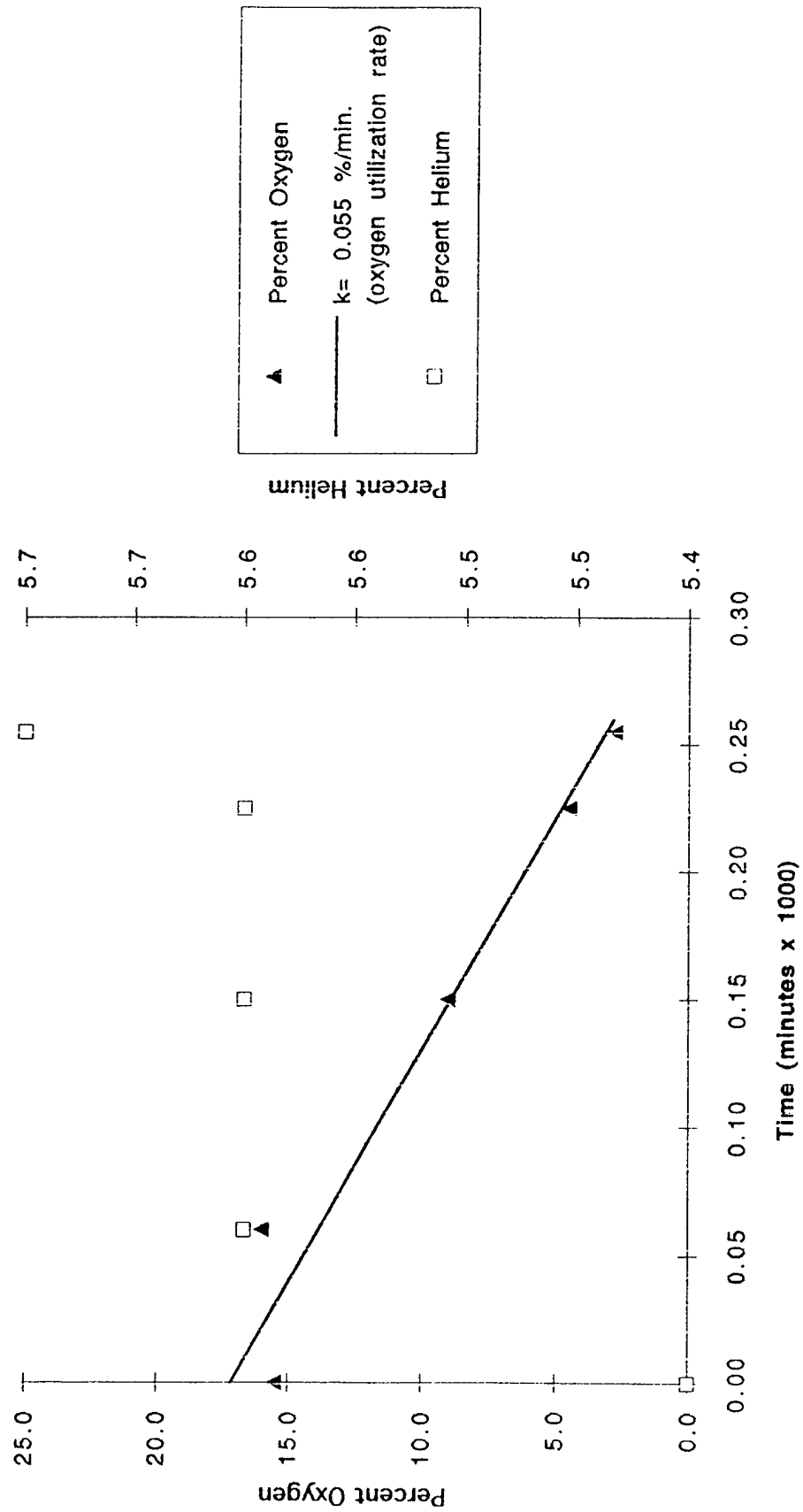

Figure 3.2

**TABLE 3.4
 OXYGEN UTILIZATION RATES
 BULK FUEL STORAGE AREA
 Pease AFB, New Hampshire**

	O ₂ Loss ⁽¹⁾ (%)	Test Duration (min)	O ₂ Utilization ⁽¹⁾ Rate (% per min)
MPB-S	15.7	2600	0.064
MPC-D	12.7	2600	0.055

¹ Values based on linear regression (Figures 3.1 through 3.2)

Because helium is a conservative, inert gas, the change in helium concentration over time can be useful in determining the effectiveness of the bentonite seals between each discrete monitoring point in the MPs. Figures 3.1 and 3.2 compare oxygen utilization and helium retention. As shown on these figures, the percent helium in the soil remained constant while the percent of oxygen decreased. Because helium will diffuse into a given medium approximately three times faster than oxygen due to helium's lower molecular weight, the oxygen loss at this site is primarily the result of bacterial respiration, not diffusion.

Based on the results of the respiration test, an estimated 3700 to 4700 mg of fuel per kilogram of soil can be biodegraded each year at the BFSA site. The interval-specific fuel consumption rates were calculated using observed oxygen utilization rates (Table 3.4), estimated air filled porosities, and a conservative ratio of 3.5 mg of oxygen consumed for every 1 mg of fuel biodegraded. The air filled porosity calculated for each test point ranged from 0.029 to 0.048 liter air per kilogram of soil.

3.5 Potential Air Emissions

The long-term potential for air emissions from full-scale bioventing operations at the BFSA site are considered to be low because of the low rates of air injection that will be used at this site. Additionally, a recent ground surface emission flux test was conducted at a similar site at another Air Force base with similar contaminants and soil type. Results of this test showed an emission rate of less than 0.002 pounds of benzene per day. Health and safety monitoring conducted at this site during the four hour permeability test, using a photoionization detector sensitive to 1 ppm, did not detect any hydrocarbons either in the breathing zone or at the ground surface. Because the potential for air emissions is highest during the initial air injection period, and no emissions were detected, the long-term air emission potential is considered low.

4.0 RECOMMENDATIONS

Initial bioventing test at the BFSA site indicate that naturally occurring oxygen has been depleted in the contaminated soils, and that air injection will be an effective method of increasing aerobic fuel biodegradation. AFCEE has recommended that air injection begin at the BFSA site to determine the long-term radius of oxygen influence and the effects of time, available nutrients and changing temperatures on fuel biodegradation rates.

A 5-horsepower rotary vane air compressor has been installed at the BFSA site to inject air at a rate of 40 cfm. This size compressor was installed to allow for expansion of the bioventing system to include multiple air injection vent wells to impact an even larger area if necessary in the future. After the one-year test period is begun, ES will return to the base at six months and one year to analyze the soil gas and conduct follow-up in-situ respiration tests. Additionally, at the one year point, ES will collect soil samples from the BFSA area to determine the soil contamination levels after one year of in-situ treatment.

Based on the results of the first year of pilot-scale bioventing, AFCEE will recommend one of three options for the BFSa site:

1. Upgrade, if necessary, and continue operation of the bioventing system.
2. If the one year soil samples indicate that significant contamination removal has occurred. AFCEE may recommend additional soil sampling to confirm that the cleanup criteria has been achieved.
3. If significant difficulties or poor results are encountered during the bioventing pilot test, AFCEE may recommend removal of the compressor system and proper abandonment of the VW and MPs.

5.0 REFERENCES

- Engineering-Science, Inc. 1993. *Draft Bioventing Test Work Plan for Bulk Fuel Storage Area, Pease AFB, New Hampshire*. August.
- Hinchee, R.E., Ong, S.K., Miller, R.N., Downey, D.C., Frandt, R. 1992. *Test Plan and Technical Protocol for a Field Treatability Test for Bioventing*. Columbus, Ohio. January.