

# LOAN DOCUMENT

PHOTOGRAPH THIS SHEET

①

DTIC ACCESSION NUMBER

LEVEL

INVENTORY

Former Bldg. 147, Bldg. 302, v Bldg. 127...  
DOCUMENT IDENTIFICATION  
Apr 94

**DISTRIBUTION STATEMENT A**  
Approved for Public Release  
Distribution Unlimited

DISTRIBUTION STATEMENT

ACCESSION FOR	
NTIS	GRAM <input checked="" type="checkbox"/>
DTIC	TRAC <input type="checkbox"/>
UNANNOUNCED	<input type="checkbox"/>
JUSTIFICATION	<input type="checkbox"/>
BY	
DISTRIBUTION/	
AVAILABILITY CODES	
DISTRIBUTION	AVAILABILITY AND/OR SPECIAL
A-1	

DISTRIBUTION STAMP

DATE ACCESSIONED

DATE RETURNED

DTIC QUALITY INSPECTED 4  
20001214 009

DATE RECEIVED IN DTIC

REGISTERED OR CERTIFIED NUMBER

PHOTOGRAPH THIS SHEET AND RETURN TO DTIC-FDAC

H  
A  
N  
D  
L  
E  
  
W  
I  
T  
H  
  
C  
A  
R  
E

**DRAFT**

*Draft Bioventing Pilot Test Work Plan for*  
**FORMER BUILDING 147, BUILDING 302,  
AND BUILDING 127**  
*at*  
**AIR FORCE PLANT 42**  
Palmdale, California

*Prepared for*  
**Air Force Center for Environmental Excellence  
Brooks AFB, Texas  
and  
Aeronautical Systems Center  
Air Force Plant 42  
Palmdale, California**

**April 1994**

*Prepared by*  
**ENGINEERING-SCIENCE, INC.**  
DESIGN • RESEARCH • PLANNING  
1301 MARINA VILLAGE PARKWAY, ALAMEDA, CA 94501 • 510/769-0100  
OFFICES IN PRINCIPAL CITIES  
57-21

**ES  
ENGINEERING-SCIENCE**

AQM01-03-0430

### DEFENSE TECHNICAL INFORMATION CENTER REQUEST FOR SCIENTIFIC AND TECHNICAL REPORTS

Title AFCEE Collection

**1. Report Availability** (Please check one box)

- This report is available. Complete sections 2a - 2f.
- This report is not available. Complete section 3.

**2a. Number of Copies Forwarded**

1 each

**2b. Forwarding Date**

July/2000

**2c. Distribution Statement** (Please check ONE box)

DoD Directive 5230.24, "Distribution Statements on Technical Documents," 18 Mar 87, contains seven distribution statements, as described briefly below. Technical documents MUST be assigned a distribution statement.

- DISTRIBUTION STATEMENT A: Approved for public release. Distribution is unlimited.
- DISTRIBUTION STATEMENT B: Distribution authorized to U.S. Government Agencies only.
- DISTRIBUTION STATEMENT C: Distribution authorized to U.S. Government Agencies and their contractors.
- DISTRIBUTION STATEMENT D: Distribution authorized to U.S. Department of Defense (DoD) and U.S. DoD contractors only.
- DISTRIBUTION STATEMENT E: Distribution authorized to U.S. Department of Defense (DoD) components only.
- DISTRIBUTION STATEMENT F: Further dissemination only as directed by the controlling DoD office indicated below or by higher authority.
- DISTRIBUTION STATEMENT X: Distribution authorized to U.S. Government agencies and private individuals or enterprises eligible to obtain export-controlled technical data in accordance with DoD Directive 5230.25, Withholding of Unclassified Technical Data from Public Disclosure, 6 Nov 84.

**2d. Reason For the Above Distribution Statement** (in accordance with DoD Directive 5230.24)

**2e. Controlling Office**

HQ AFCEE

**2f. Date of Distribution Statement Determination**

15 Nov 2000

**3. This report is NOT forwarded for the following reasons.** (Please check appropriate box)

- It was previously forwarded to DTIC on ..... (date) and the AD number is .....
- It will be published at a later date. Enter approximate date if known. ....
- In accordance with the provisions of DoD Directive 3200.12, the requested document is not supplied because: .....

**Print or Type Name**

Laura Peña

**Telephone**

210-536-1431

**Signature**

Laura Peña

(For DTIC Use Only)

**AQ Number**

0101-02-0430

**DRAFT**

*Draft Bioventing Pilot Test Work Plan for*  
**FORMER BUILDING 147, BUILDING 302,  
AND BUILDING 127**  
*at*  
**AIR FORCE PLANT 42**  
Palmdale, California

*Prepared for*

**Air Force Center for Environmental Excellence  
Brooks AFB, Texas  
and  
Aeronautical Systems Center  
Air Force Plant 42  
Palmdale, California**

**April 1994**

*Prepared by*

**ENGINEERING-SCIENCE, INC.**  
DESIGN • RESEARCH • PLANNING  
1301 MARINA VILLAGE PARKWAY, ALAMEDA, CA 94501 • 510/769-0100  
OFFICES IN PRINCIPAL CITIES  
57-21

## TABLE OF CONTENTS

**Draft Bioventing Pilot Test Work Plan for  
Former Building 147, Building 302, and Building 127  
at  
Air Force Plant 42  
Palmdale, California**

	<u>Page</u>
1.0 INTRODUCTION.....	1
1.1 Bioventing Pilot Test Organization.....	1
1.2 Air Force Plant 42 Background.....	2
1.3 Air Force Plant 42 Geology and Environmental Setting.....	2
2.0 SITE DESCRIPTIONS.....	6
2.1 Former Building 147 (Tanks T1-1 and T1-2).....	6
2.1.1 Site Location and History.....	6
2.1.2 Site Geology.....	6
2.1.3 Site Contaminants.....	6
2.2 Building 302 (Tanks T3-8 through T3-13).....	6
2.2.1 Site Location and History.....	6
2.2.2 Site Geology.....	11
2.2.3 Site Contaminants.....	11
2.3 Alternate Site: Building 127 (Tank T1-11).....	14
2.3.1 Site Location and History.....	14
2.3.2 Site Geology.....	14
2.3.3 Site Contaminants.....	14
3.0 SITE-SPECIFIC ACTIVITIES.....	17
3.1 Locations of Vent Wells and Vapor Monitoring Points.....	17
3.1.1 Former Building 147.....	17
3.1.2 Building 302.....	19
3.1.3 Alternate Site: Building 127.....	19
3.2 Construction of Vent Wells.....	19
3.3 Construction of Vapor Monitoring Points.....	23
3.4 Handling of Drill Cuttings and Asphalt Debris.....	23
3.5 Soil and Soil-Gas Sampling.....	23
3.5.1 Soil Sampling.....	23
3.5.2 Soil-Gas Sampling.....	25
3.6 Blower System.....	25
3.7 <i>In Situ</i> Respiration Tests.....	27
3.8 Air Permeability Tests.....	27
3.9 Potential Air Emissions.....	27
3.10 Installation of Extended Bioventing Pilot Test Systems.....	28

TABLE OF CONTENTS (Continued)

	<u>Page</u>
4.0 EXCEPTIONS TO PROTOCOL PROCEDURES .....	29
5.0 BASE SUPPORT REQUIREMENTS.....	30
6.0 PROJECT SCHEDULE .....	32
7.0 POINTS OF CONTACT.....	33
8.0 REFERENCES .....	34

## LIST OF FIGURES

<u>Figure</u>	<u>Page</u>
1.1 Site Location Map .....	3
1.2 Site Map - Air Force Plant 42.....	4
2.1 Site Map - Former Building 147 and Building 127 .....	7
2.2 Soil Sample Locations, Former Building 147 .....	8
2.3 Site Map - Building 302 .....	10
2.4 Soil Sample Locations, Building 302.....	12
2.5 Soil Sample Locations, Building 127.....	15
3.1 Proposed Vent Well, Vapor Monitoring Point, and Background Well Locations - Former Building 147 .....	18
3.2 Proposed Vent Well and Vapor Monitoring Point Locations - Building 302.....	20
3.3 Proposed Vent Well and Vapor Monitoring Point Locations - Building 127.....	21
3.4 Vent Well Construction Diagram (Typical).....	22
3.5 Vapor Monitoring Point Construction Diagram (Typical) .....	24
3.6 Blower Process Flow and Instrumentation Diagram for Air Injection .....	26

LIST OF TABLES

<u>Table</u>	<u>Page</u>
2.1 Soil Analytical Results at Former Building 147.....	9
2.2 Soil Analytical Results at Building 302 .....	13
2.3 Soil Analytical Results at Building 127 .....	16

**DRAFT BIOVENTING PILOT TEST WORK PLAN FOR  
FORMER BUILDING 147, BUILDING 302, AND BUILDING 127  
at  
AIR FORCE PLANT 42  
Palmdale, California**

**1.0 INTRODUCTION**

This Draft Pilot Test Work Plan presents the scope of *in situ* bioventing pilot tests for treatment of fuel contaminated soils at three sites at Air Force Plant 42 (AFP 42), Palmdale, Los Angeles County, California. Bioventing pilot tests will be conducted at two of the three sites, with the third site serving as an alternate site in case initial conditions at one of the two primary sites are not appropriate for pilot testing.

**1.1 Bioventing Pilot Test Organization**

The bioventing pilot test has three primary objectives. These are: 1) to assess the potential for supplying oxygen throughout the fuel hydrocarbon-contaminated soil zone, 2) to determine the rate at which indigenous microorganisms will degrade the fuel in the soil when stimulated by oxygen-rich soil gas, and 3) to evaluate the potential for sustaining these rates of fuel biodegradation until the contamination is remediated below regulatory standards.

The bioventing pilot test at each site will be divided into two test events. An initial pilot test will determine the technical feasibility and important design parameters such as air permeability, radius of influence, and fuel biodegradation rates. An extended (one-year) pilot test will determine the longer term application of this remedial technology to degrade hydrocarbons at each individual site. If bioventing proves to be applicable, pilot test data could be used to design and implement a bioventing remediation system. A significant amount of the fuel contamination should be biodegraded during the extended (one-year) pilot tests since bioventing will take place within the most contaminated soils at each site.

Additional background information on the development and recent success of the bioventing technology is found in the document entitled "Test Plan and Technical Protocol for a Field Treatability Test for Bioventing" (Hinchee et al. 1992). This protocol document will also serve as the primary reference for the pilot test well designs and detailed procedures which will be used during the test.

Much of the background information used in this Draft Bioventing Pilot Test Work Plan is derived from prior studies and reports, which are listed in Section 8.0.

## **1.2 Air Force Plant 42 Background**

AFP 42 is located in Palmdale, California, approximately 70 miles north of Los Angeles. The site is approximately 3 miles east of Highway 14 between Avenue M and Avenue P (Figure 1.1). The plant covers an area of approximately 6,000 acres. Surrounding land use includes light industrial, commercial, agricultural, and residential.

The original airfield was established in 1940 as a U.S. Army Air Corps facility. The airfield was acquired by Los Angeles County after World War II and was used as a county airport. In the early 1950's, the U.S. Air Force (USAF) began to manufacture and test aircraft at the facility. AFP 42 officially became a USAF facility in 1953.

The USAF, Aeronautical Systems Division, currently controls the plant and provides space to various tenants for industrial activities. The plant consists of an airfield and eight separate industrial zones (numbered Site 1 through Site 8). Each tenant conducts their operations within their own site. Seven of the eight sites are currently occupied and controlled by Department of Defense (DOD) contractors for manufacture and testing of aircraft. Contractors include Lockheed Aeronautical Systems, Rockwell International, and Northrop. Site 5 is designated as the administrative area, consisting of common areas between sites including the airfield. Bioventing sites of interest in this report are located in Site 1 and Site 3, which are currently occupied by Rockwell and Northrop, respectively (Figure 1.2).

A large number of underground storage tanks (USTs) were installed at the plant to support DOD contractor activities. The majority of these tanks provided storage for various petroleum products. In 1993, 51 USTs were removed as part of a closure contract. Soil beneath some of the tanks showed evidence of soil contamination.

## **1.3 Air Force Plant 42 Geology and Environmental Setting**

AFP 42 is located in the southern corner of Antelope Valley. This valley is a wedged-shaped, closed sedimentary basin. It is bordered by the Tehachapi Mountains to the northwest, the San Gabriel Mountains on the south, and by the San Andreas and Garlock fault zones.

Erosion of the uplifted rocks in Antelope Valley during the Tertiary and Quaternary periods filled the valley with unconsolidated sediments, which rest directly on basement rocks in most of the valley. Alluvial materials deposited in the basin consist of poorly sorted gravel, sand, silt, and clay of granitic origin. These materials comprise the principal source of ground water in the Antelope Valley. Overlying younger alluvium deposits consist of finer sediments generally less than 150 feet thick. Surface soils are characterized as primarily immature sandy loams and are low in clay and natural organic materials.

The Antelope Valley groundwater basin is divided into sub-basins based on fault locations, consolidated rock bodies, and groundwater divides. AFP 42 is located near the southern boundary of the Lancaster sub-basin, which is the largest sub-basin and contains the greatest quantity of groundwater. Two major aquifers are identified within the Lancaster sub-basin. They are designated as "principal" and "deep" aquifer zones

FIGURE 1.1

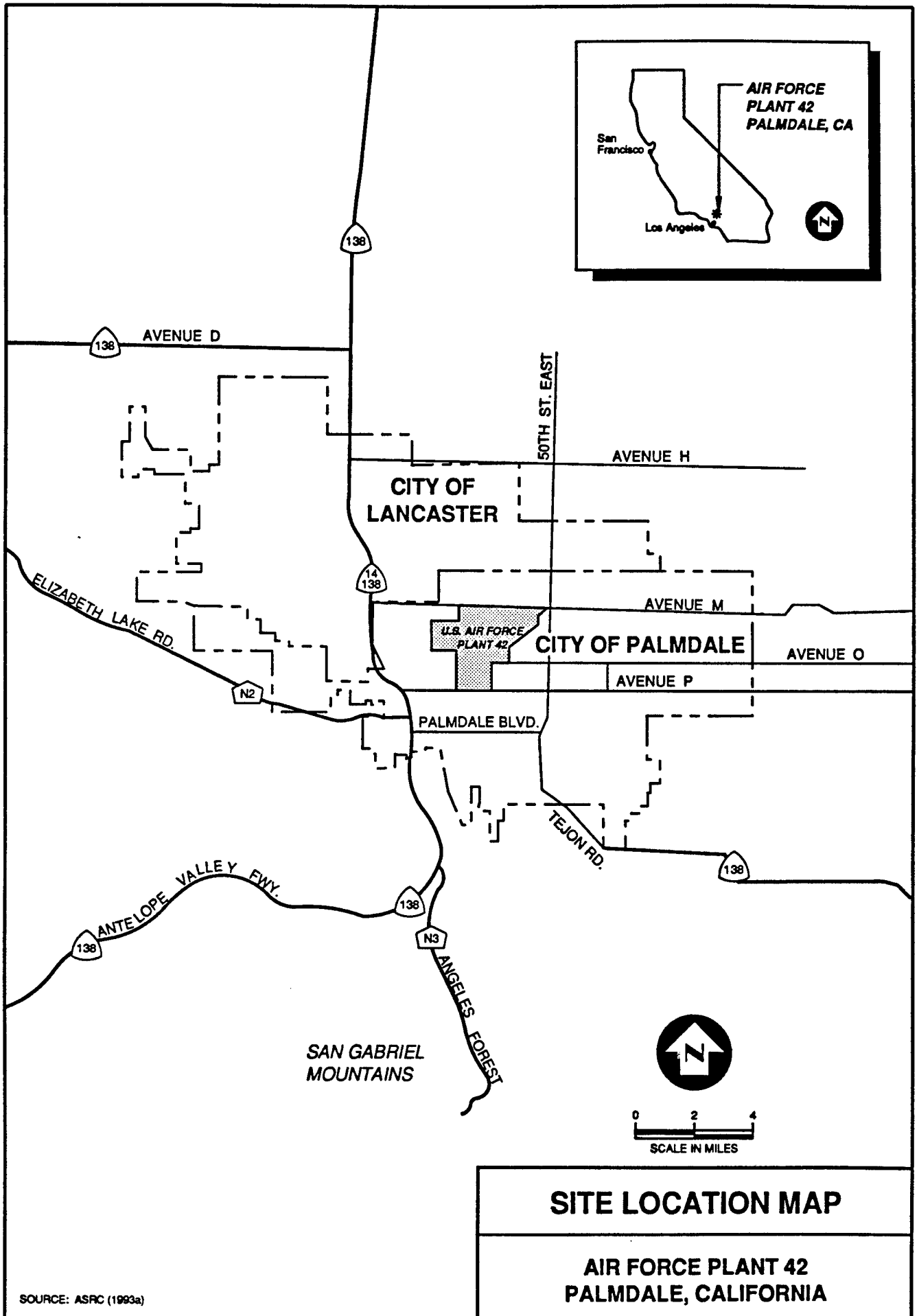

SOURCE: ASRC (1993a)

REV. 2 C272-10.DWG 03/30/94

### SITE LOCATION MAP

**AIR FORCE PLANT 42  
PALMDALE, CALIFORNIA**

ENGINEERING-SCIENCE, INC.

FIGURE 1.2

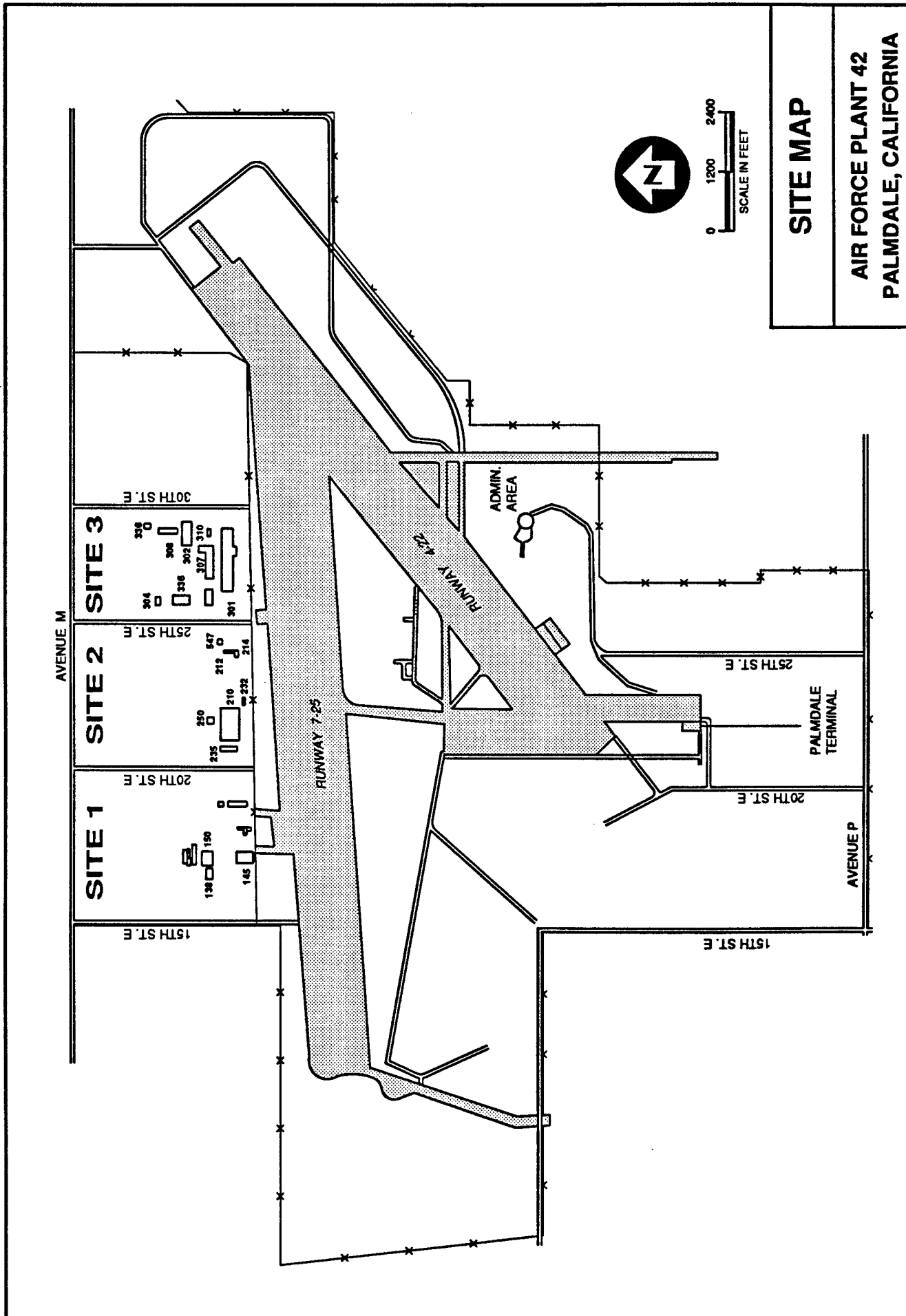

**SITE MAP**

**AIR FORCE PLANT 42**

**PALMDALE, CALIFORNIA**

(CH2M Hill, 1983). The principal aquifer is unconfined and separated from the deep aquifer by a confining clay bed occurring at depths ranging from 600 feet below ground surface (bgs) to more than 1,000 feet bgs in the vicinity of AFP 42. The confining clay bed is believed to be associated with buried lake deposits found in the vicinity and north of AFP 42 (USGS Water Resources Division, 1967).

Groundwater beneath AFP 42 is reported to occur at a depth of approximately 300 feet bgs (CH2M Hill, 1983). Historically, the direction of groundwater flow within the western portion of Lancaster sub-basin has been toward a major agricultural well field located northeast of AFP 42.

Surface water runoff follows the topography in small channels and is generally to the north (ES 1988). A drainage system, consisting of storm drains and shallow ditches, directs surface water to a percolation pond north of Avenue M.

The topography in the area is relatively flat and the ground surface is composed of coarse sand and fine gravel. The climate is typical of a desert environment.

## **2.0 SITE DESCRIPTIONS**

The following sections provide a brief summary of the location, history, geology, and known contaminant distribution at the two primary sites and the one alternate site where bioventing pilot testing may occur.

### **2.1 Former Building 147 (Tanks T1-1 and T1-2)**

#### **2.1.1 Site Location and History**

Former Building 147 is located within Site 1 and is the former location of two USTs, designated tanks T1-1 and T1-2. The site is located along the southern boundary of Site 1, south of Building 145 and outside the southern boundary fence (Figure 2.1). The site is not paved.

Tanks T1-1 and T1-2 were utilized for JP-5 fueling operations for testing aircraft and were installed sometime in the late 1950's or early 1960's. Both 25,000-gallon tanks passed tank integrity tests in 1987 (Hargis, 1989). The tanks were removed in March of 1993 and the excavations were backfilled with clean soil. Plastic liners were installed at the base of the excavation (approximately 16 feet bgs) before backfilling.

#### **2.1.2 Site Geology**

No detailed investigations have been performed at the site. Soil exposed during other tank removal operations at Site 1 were described as uniformly consolidated, dry, light brown, silty, fine to medium sand to maximum excavation depths of 32 feet. A similar soil profile was encountered during the drilling of groundwater monitoring wells in another area of AFP 42 (JMM, 1992).

#### **2.1.3 Site Contaminants**

Petroleum hydrocarbons and purgeable aromatics have been detected in soils at the site. During tank removal operations in March 1993, soil samples were collected from the bottom of the excavation at approximately 16 feet bgs. Sample locations are indicated on Figure 2.2, and analytical results are summarized in Table 2.1.

Soil samples from the excavation base were analyzed for total petroleum hydrocarbons-heavy fraction (TPH-heavy), total recoverable petroleum hydrocarbons (TRPH), and purgeable aromatics including benzene, toluene, ethylbenzene, and total xylenes (BTEX). The maximum levels of contaminants found were 870 mg/kg TPH-heavy, 5,800 mg/kg TRPH, 84 mg/kg toluene, 52 mg/kg ethylbenzene, and 260 mg/kg total xylenes. These maximum levels were all found in sample 1A taken beneath tank T1-1. Benzene was not detected in any soil samples.

### **2.2 Building 302 (Tanks T3-8 through T3-13)**

#### **2.2.1 Site Location and History**

Building 302 is the former location of six USTs, designated T3-8 through T3-13. The site is located in the southeast portion of Site 3 (Figure 2.3). The area is paved with asphalt.

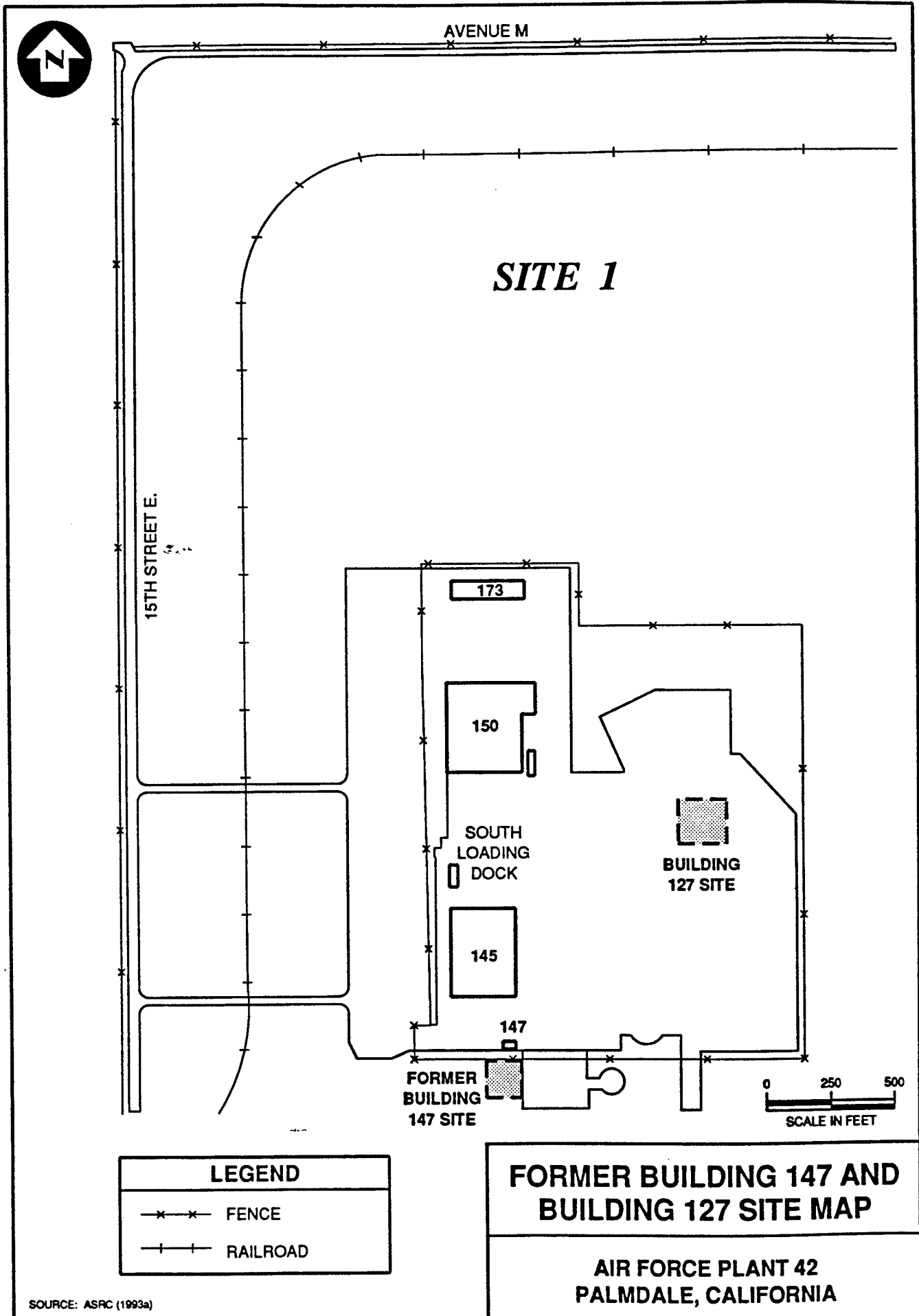

SOURCE: ASFC (1993a)

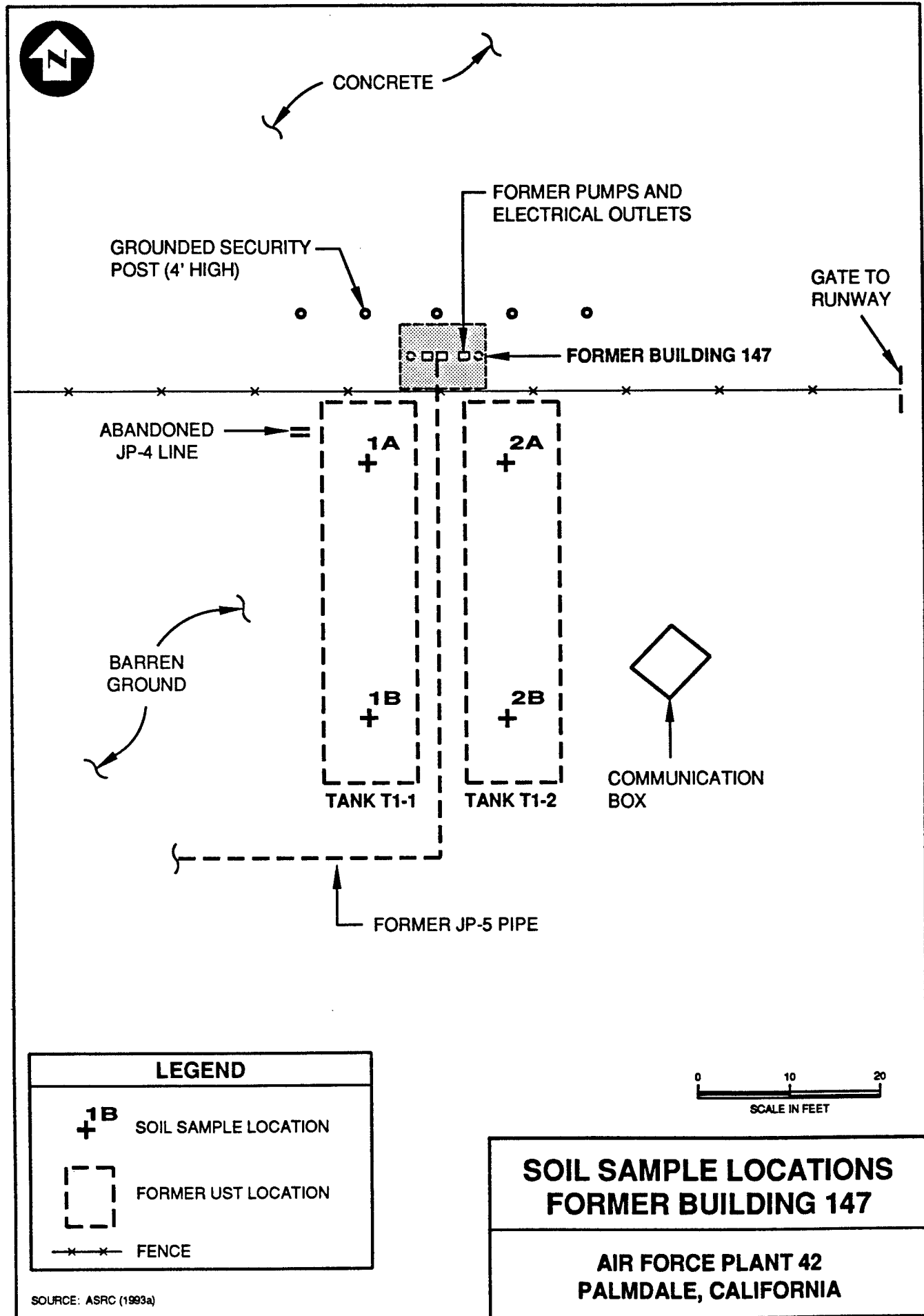

LEGEND	
	SOIL SAMPLE LOCATION
	FORMER UST LOCATION
	FENCE

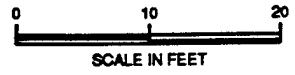

**SOIL SAMPLE LOCATIONS  
FORMER BUILDING 147**

**AIR FORCE PLANT 42  
PALMDALE, CALIFORNIA**

**ENGINEERING-SCIENCE, INC.**

SOURCE: ASRC (1993a)

**Table 2.1**  
**Soil Analytical Results at**  
**Former Building 147**  
**AFP 42, Palmdale, California**

Tank	Sample No.	Depth (ft bgs)	Total Petroleum HC		Purgeable Aromatics				Moisture Content (%)	
			Method:	8015M	418.1	8020				
			Analyte:	TPH-heavy	TRPH	Benzene	Toluene	Ethylbenzene		Total Xylenes
			concentrations in mg/kg							
T1-1	1A	16	870	5,800	<3.0	84	52	260	14.46	
	1B	16	<20	<20	<0.005	<0.005	<0.005	<0.01	12.23	
T1-2	2A	16	600	2,900	<0.3	1.6	<0.3	33	12.93	
	2B	16	<20	35	<0.005	<0.005	<0.005	<0.01	13.15	

<i>LEGEND</i>	
<p>bgs : below ground surface</p> <p><span style="background-color: #cccccc; border: 1px solid black; padding: 2px;">&lt;20</span> : below given detection limit</p>	<p>TPH-heavy : Total petroleum hydrocarbons (heavy fraction)</p> <p>TRPH : Total recoverable petroleum hydrocarbons</p>
Source: ASRC (1993a)	

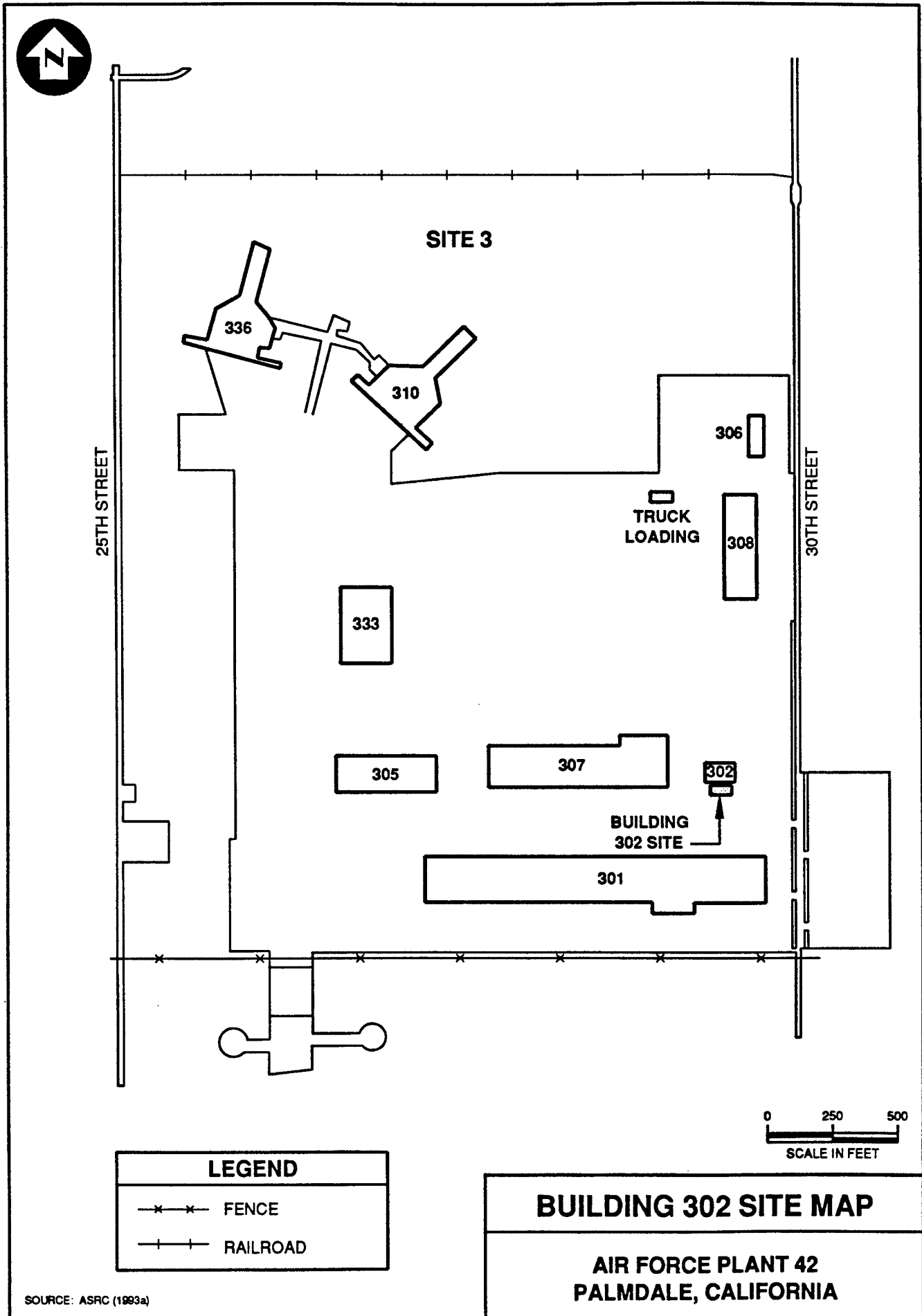

Tanks T3-9 through T3-12, approximately 30,000-gallon capacity each, and tank T3-13, approximately 5,000-gallon capacity, were used to store fuel oil #2. Tank T3-8, 100-gallon capacity, was used to store gasoline. All six tanks were installed sometime in the late 1950's or early 1960's. All tanks except tank T3-11 passed integrity tests in 1987. Tank T3-11 was retested in 1988 and passed (Hargis, 1989).

All six tanks were removed in February 1993 and the excavations were backfilled with clean soil. Plastic liners were installed at the base of the excavation before backfilling.

### **2.2.2 Site Geology**

No detailed investigations have been performed at the site. Soil exposed during tank removal operations was described as uniformly consolidated, dry, light brown, silty, fine to medium sand to the maximum excavation depth of 28 feet beneath tanks T3-9 through T3-11. A similar soil profile was encountered during the drilling of groundwater monitoring wells in another area of AFP 42 (JMM 1992).

### **2.2.3 Site Contaminants**

Petroleum hydrocarbons and purgeable aromatics have been detected in soils at the site. During tank removal operations in February 1993, 15 soil samples were collected from the bottom of the approximately 17-foot deep excavation. Overexcavation to a maximum depth of 28 feet bgs at the northern end of the tanks was performed in an effort to remove contaminated soil. Ten additional samples were collected during overexcavation. Sample locations are indicated on Figure 2.4, and analytical results are summarized in Table 2.2.

Soil samples from the excavation bottom were analyzed for TPH-heavy, TRPH, and BTEX. The maximum levels of contaminants found at 17 feet bgs were: 18,000 mg/kg TPH-heavy, 16,000 mg/kg TRPH, 0.09 mg/kg toluene, 22 mg/kg ethylbenzene, and 1.5 mg/kg total xylenes. These maximum levels were all found at sample location 11A beneath tank T3-11. After overexcavation, the maximum levels of contaminants found were: 2,500 mg/kg TPH-heavy (T31126) and 0.02 mg/kg total xylenes (T3926). Benzene was not detected in any samples.

The results from 17 feet bgs indicate that the majority of the TPH contamination originated from the north sides of tanks T3-11 and T3-13, although TPH concentrations above 100 mg/kg were found throughout the excavation bottom at all other tanks. After overexcavation of soil to 26 feet bgs, the TPH concentration beneath T3-11 had decreased by one order of magnitude, although the concentration was still significant (no overexcavation sample was collected beneath T3-13). In contrast, TPH levels at 26 feet bgs had increased beneath T3-12 and T3-9, which are immediately adjacent to T3-11 and T3-13, respectively (see Figure 2.2). These results suggest that vertical and lateral spreading of the contamination beneath T3-11 and T3-13 has occurred, although the extent remains unknown.

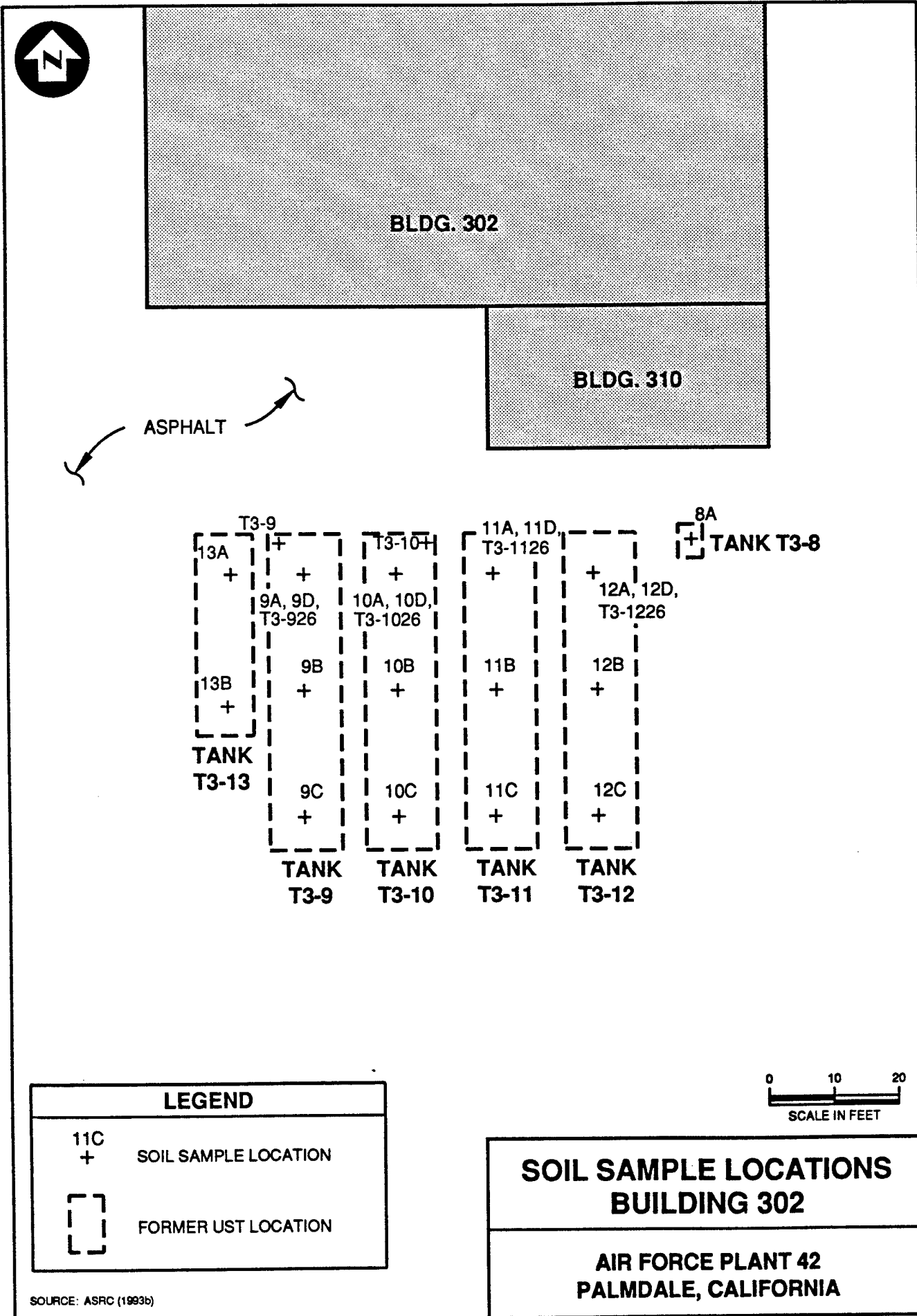

LEGEND	
11C +	SOIL SAMPLE LOCATION
[ ]	FORMER UST LOCATION



**SOIL SAMPLE LOCATIONS  
BUILDING 302**

**AIR FORCE PLANT 42  
PALMDALE, CALIFORNIA**

SOURCE: ASRC (1993b)

**Table 2.2**  
**Soil Analytical Results at**  
**Building 302**  
**AFP 42, Palmdale, California**

Tank	Sample No.	Depth (ft bgs)	Total Petroleum HC		Purgeable Aromatics				Moisture Content (%)	
			Method:	8015M	418.1	8020				
			Analyte:	TPH-heavy	TRPH	Benzene	Toluene	Ethylbenzene		Total Xylenes
concentrations in mg/kg										
T3-8	8A	17	<20	170	<0.005	<0.005	<0.005	<0.01	13.20	
T3-9	9A	17	<20	110	<0.005	<0.005	<0.005	<0.01	3.34	
	9B	17	<20	150	<0.005	<0.005	<0.005	<0.01	8.09	
	9C	17	<20	220	<0.005	<0.005	<0.005	<0.01	10.96	
	9D	24	<20	NS	<0.005	<0.005	<0.005	<0.01	6.44	
	T3926	26	1,000	NS	<0.005	<0.005	<0.005	0.02	3.63	
	T3-9	28	<20	<20	<0.005	<0.005	<0.005	<0.01	5.45	
T3-10	10A	17	170	230	<0.005	<0.005	<0.005	<0.01	13.42	
	10B	17	<20	230	<0.005	<0.005	<0.005	<0.01	7.72	
	10C	17	<20	140	<0.005	<0.005	<0.005	<0.01	6.22	
	10D	24	<20	NS	<0.005	<0.005	<0.005	<0.01	16.50	
	T31026	26	11	NS	<0.005	<0.005	<0.005	<0.01	9.51	
	T3-10	28	<20	<20	<0.005	<0.005	<0.005	<0.01	5.39	
T3-11	11A	17	18,000	16,000	<0.005	0.09	22	1.5	13.62	
	11B	17	<20	110	<0.005	<0.005	<0.005	<0.01	3.16	
	11C	17	<20	110	<0.005	<0.005	<0.005	<0.01	3.90	
	11D	24	<20	NS	<0.005	<0.005	<0.005	<0.01	4.53	
	T31126	26	2,500	NS	<0.005	<0.005	<0.005	<0.01	8.55	
T3-12	12A	17	<20	170	<0.005	<0.005	<0.005	<0.01	7.97	
	12B	17	<20	170	<0.005	<0.005	<0.005	<0.01	7.99	
	12C	17	<20	150	<0.005	<0.005	<0.005	<0.01	8.91	
	12D	24	<20	150	<0.005	<0.005	<0.005	<0.01	11.01	
	T31226	26	1,700	NS	<0.005	<0.005	<0.005	<0.01	6.29	
T3-13	13A	17	140	1,200	<0.005	<0.005	<0.005	0.02	7.17	
	13B	17	<20	160	<0.005	<0.005	<0.005	<0.01	10.90	

**LEGEND**

bgs : below ground surface

NS : not sampled

<20 : below given detection limit

TPH-heavy : Total petroleum hydrocarbons (heavy fraction)

TRPH : Total recoverable petroleum hydrocarbons

Source: ASRC (1993a)

## **2.3 Alternate Site: Building 127 (Tank T1-11)**

### **2.3.1 Site Location and History**

Building 127 is located in the eastern portion of Site 1 (Figure 2.1). It is the former location of tank T1-11, a 50,000-gallon capacity tank used to store jet fuel (JP-5). The tank was installed sometime in the late 1960's or early 1970's. The site is paved with asphalt and concrete.

Tank T1-11 failed an integrity test in 1988; however, results from that test were determined to be inconclusive. The tank was removed in April 1993 and the excavation was backfilled with clean soil. A plastic liner was installed at the base of the excavation before backfilling.

### **2.3.2 Site Geology**

No detailed investigations have been performed at the site. Soil exposed during other tank excavations at Site 1 were described as uniformly consolidated, dry, light brown, silty, fine to medium sand to maximum excavation depths of 32 feet. A similar soil profile was encountered during the drilling of groundwater monitoring wells in another area of AFP 42 (JMM, 1992).

### **2.3.3 Site Contaminants**

Petroleum hydrocarbons have been detected in soils at the site. During tank removal operations in April 1993, four soil samples were collected from the bottom of the approximately 20-foot deep excavation. Sample locations are indicated on Figure 2.5, and analytical results are summarized in Table 2.3.

Soil samples from the excavation bottom were analyzed for TPH-heavy, TRPH, and BTEX. The maximum levels of contaminants found were: 4,400 mg/kg TPH-heavy (10B), and 4,400 mg/kg TRPH (10B and 10C). No BTEX compounds were detected.

FIGURE 2.5

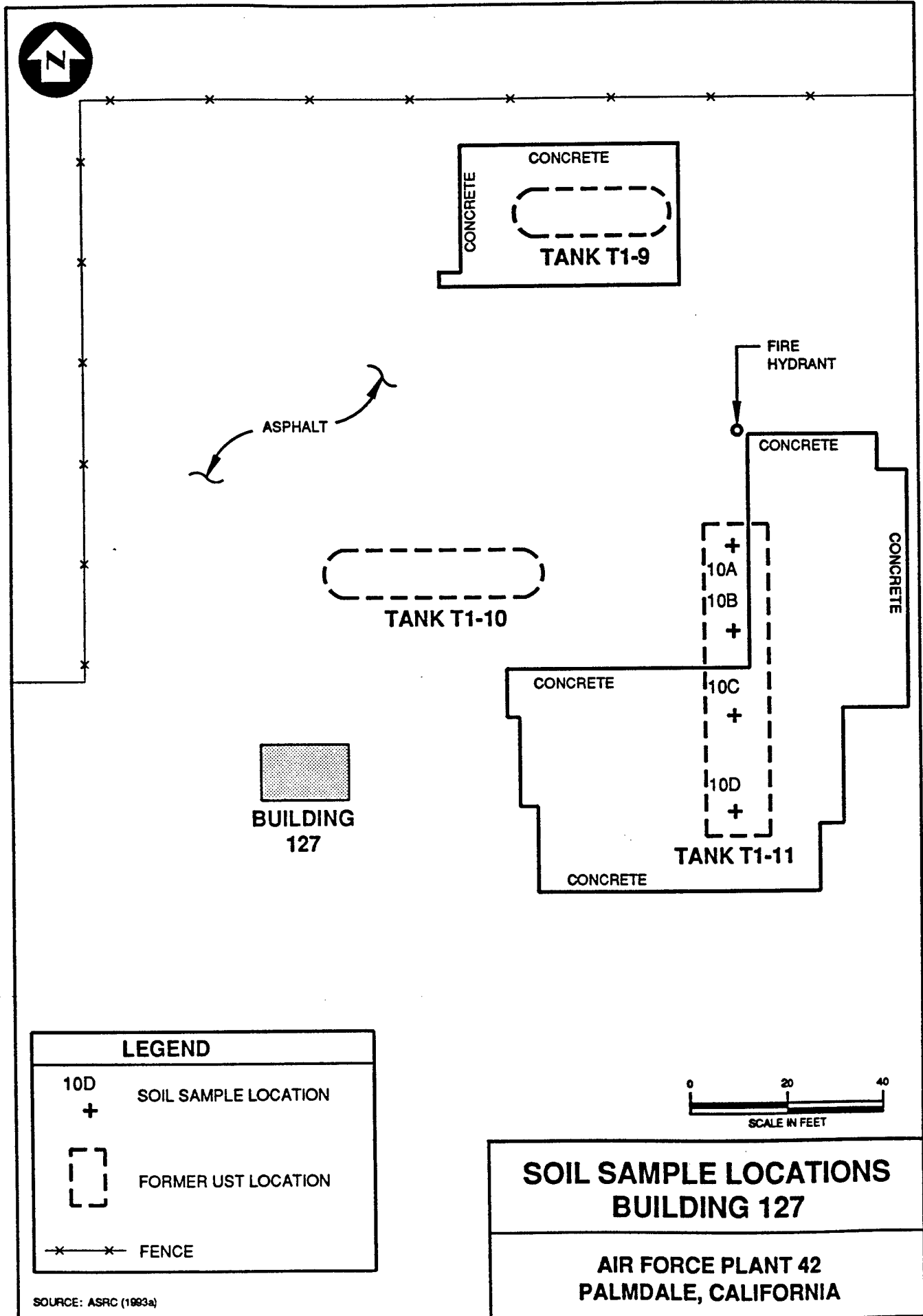

SOURCE: ASRC (1993a)

REV. 2 C272-16.DWG 04/07/94

ENGINEERING-SCIENCE, INC.

**Table 2.3  
Soil Analytical Results at  
Building 127  
AFP 42, Palmdale, California**

Tank	Sample No.	Depth (ft bgs)	Total Petroleum HC		Purgeable Aromatics				
			Method:	8015M	418.1	8020			
			Analyte:	TPH-heavy	TRPH	Benzene	Toluene	Ethylbenzene	Total Xylenes
			concentrations in mg/kg						
T1-11	10A	20	<20	<20	<0.005	<0.005	<0.005	<0.01	
	10B	20	4,400	4,400	<0.005	<0.005	<0.005	<0.01	
	10C	20	240	4,300	<0.005	<0.005	<0.005	<0.01	
	10D	20	<20	<20	<0.005	<0.005	<0.005	<0.01	

LEGEND	
bgs : below ground surface	TPH-heavy : Total petroleum hydrocarbons (heavy fraction)
 <20 : below given detection limit	TRPH : Total recoverable petroleum hydrocarbons
Source: ASRC (1993a)	

### 3.0 SITE-SPECIFIC ACTIVITIES

The purpose of this section is to describe the work that will be performed by Engineering-Science, Inc. at the two primary sites and the alternate site if conditions at one of the two primary sites are not suitable for bioventing. Activities that will be performed include siting and construction of a central VW and VMPs, an initial pilot test (including an *in situ* respiration test and an air permeability test), and an extended (one-year) pilot test. Soil and soil-gas sampling procedures and the blower configuration that will be used to introduce air (oxygen) into contaminated soils by injection are also discussed in this section.

No dewatering or groundwater treatment will take place during the pilot testing. Pilot test activities will be confined to unsaturated soils remediation. Subsurface soils are expected to be composed of mostly interbedded sands, silts, and silty sands which should be suitable for the bioventing technology. Existing soil analytical data (Table 2.1 and Table 2.2) show the subsurface profile will probably contain sufficient moisture to sustain some degree of respiration and biodegradation for the duration of the pilot tests, although the moisture contents for some samples are at the low end of the range considered optimum. An important focus of the pilot testing at these sites will be to evaluate the effect of existing moisture content on biodegradation rates. Soils at all sites are expected to contain sufficient nutrient levels and these levels will be measured during initial soil sampling, which is described in this section.

#### 3.1 Locations of Vent Wells and Vapor Monitoring Points

A general description of criteria used for siting a central VW and VMPs is included in the protocol document. The proposed VW and VMP locations and the siting criteria used for each site are described below. The proposed location for the background VMP is described in Section 3.1.1.

The final locations of VWs and VMPs may vary slightly from the proposed locations if evidence of significant fuel contamination is not observed in borings. VWs will be located in areas of high fuel contamination which also is expected to be oxygen depleted (less than 2%). Increased biological activity should be stimulated by oxygen-rich soil gas ventilation during both the initial and extended pilot tests.

##### 3.1.1 Former Building 147

Figure 3.1 shows the proposed location of the blower, the central VW, and the VMPs for Former Building 147. The VW and VMP locations were chosen based upon the high degree of contamination indicated by the analytical results for soil samples 1A and 2A (see Figure 2.1 and Table 2.1).

The radius of venting influence around the central VW is expected to be about 50 to 60 feet based upon the predominance of sands and silts in subsurface soils at the site and upon the expected depth of contamination at greater than 15 feet. The three VMPs are to be located at distances from the central VW which should provide adequate coverage over this expected radius of influence.

FIGURE 3.1

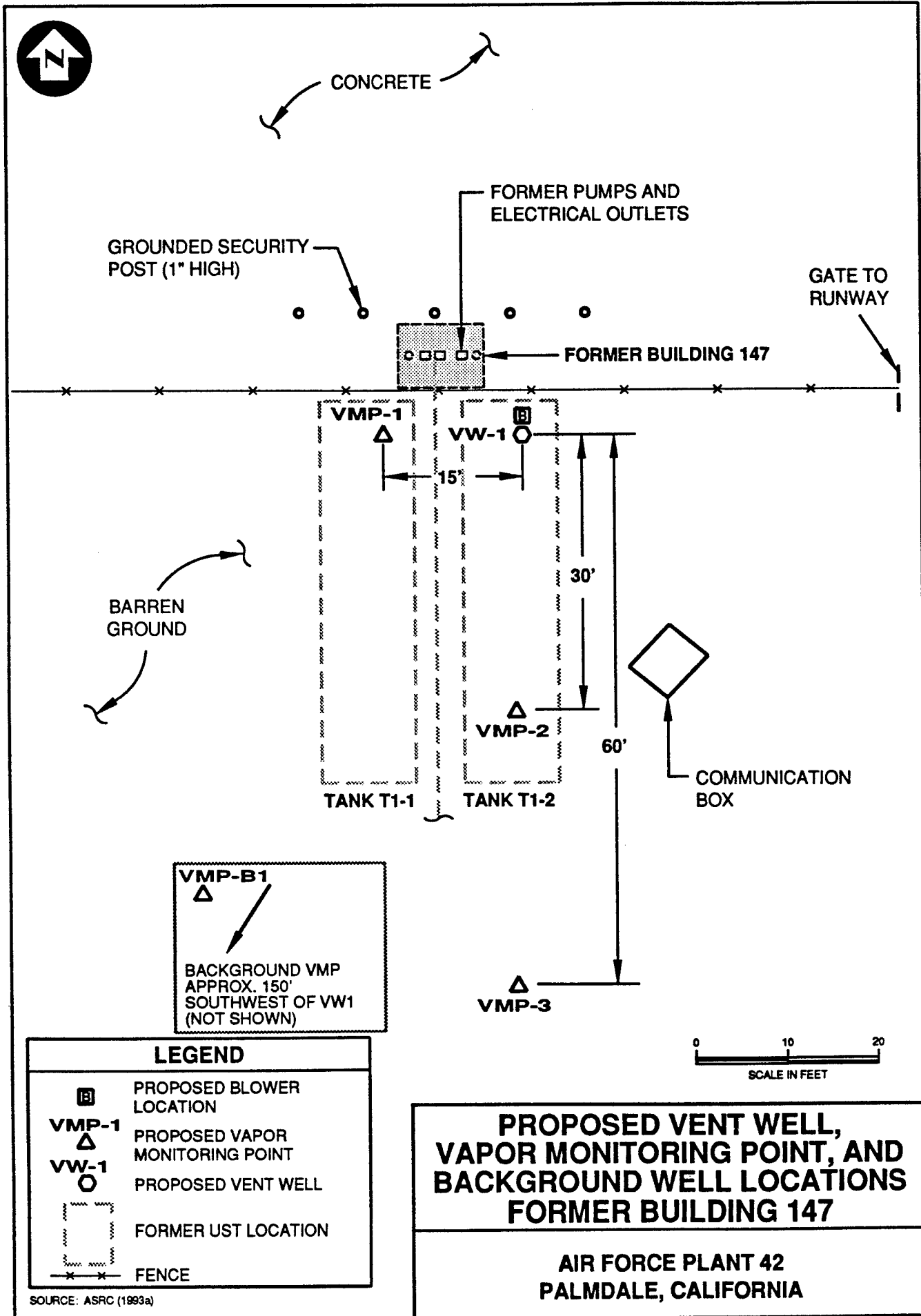

SOURCE: ASRC (1993a)

**PROPOSED VENT WELL,  
VAPOR MONITORING POINT, AND  
BACKGROUND WELL LOCATIONS  
FORMER BUILDING 147**

**AIR FORCE PLANT 42  
PALMDALE, CALIFORNIA**

One background VMP for AFP 42 will be installed as part of the initial pilot tests. The background VMP will be used to measure background levels of oxygen and carbon dioxide and to determine if inorganic or natural carbon sources may be contributing to oxygen uptake during the *in situ* respiration tests (described in Section 3.7).

The background VMP will be installed approximately 150 feet southwest of the Former Building 147 site, in an empty field. This location is not within any known contaminated area (Figure 3.1).

### **3.1.2 Building 302**

Figure 3.2 shows the proposed location of the blower, the central VW, and the VMPs for Building 302. The VW and VMP locations were chosen based upon the high degree of contamination indicated by the analytical results for soil samples taken at the north end of the excavation (see Figure 2.2 and Table 2.2).

The radius of venting influence around the central VW is expected to be about 50 to 60 feet based upon the predominance of sands and silts in subsurface soils at the site and upon the expected depth of contamination at greater than 15 feet. The three VMPs are to be located at distances from the central VW which should provide adequate coverage over this expected radius of influence.

### **3.1.3 Alternate Site: Building 127**

Figure 3.3 shows the proposed location of the blower, the central VW, and the VMPs for Building 127. The VW and VMP locations were chosen based upon the high degree of contamination indicated by the analytical results for soil sample locations 10B and 10C (see Figure 2.3 and Table 2.3).

The radius of venting influence around the central VW is expected to be about 50 to 60 feet based upon the predominance of sands and silts in subsurface soils at the site and upon the expected depth of contamination at greater than 15 feet. The three VMPs are to be located at distances from the central VW which should provide adequate coverage over this expected radius of influence.

## **3.2 Construction of Vent Wells**

A typical construction diagram for the central VW at each site is shown in Figure 3.4. The central VW will be constructed of 4-inch ID schedule 40 PVC casing, with an interval of 0.04-inch slotted screen typically set between the initially encountered contamination (but a minimum of 5 feet bgs) down to the base of contamination as determined by field organic vapor analysis (OVA) of soil sample head space. The start of the screen interval may be set lower than the uppermost zone of soil contamination to prevent short-circuiting of injected air within any excavation fill material. A 100 ppmv OVA reading will be the criterion used in determining the selected depths. A GasTech™ Total Hydrocarbon Vapor Analyzer (THVA) will be used to collect field OVA readings. This platinum catalyst combustion detector is calibrated with hexane, which provides a conservative reading representative of total petroleum hydrocarbon vapors present.

FIGURE 3.2

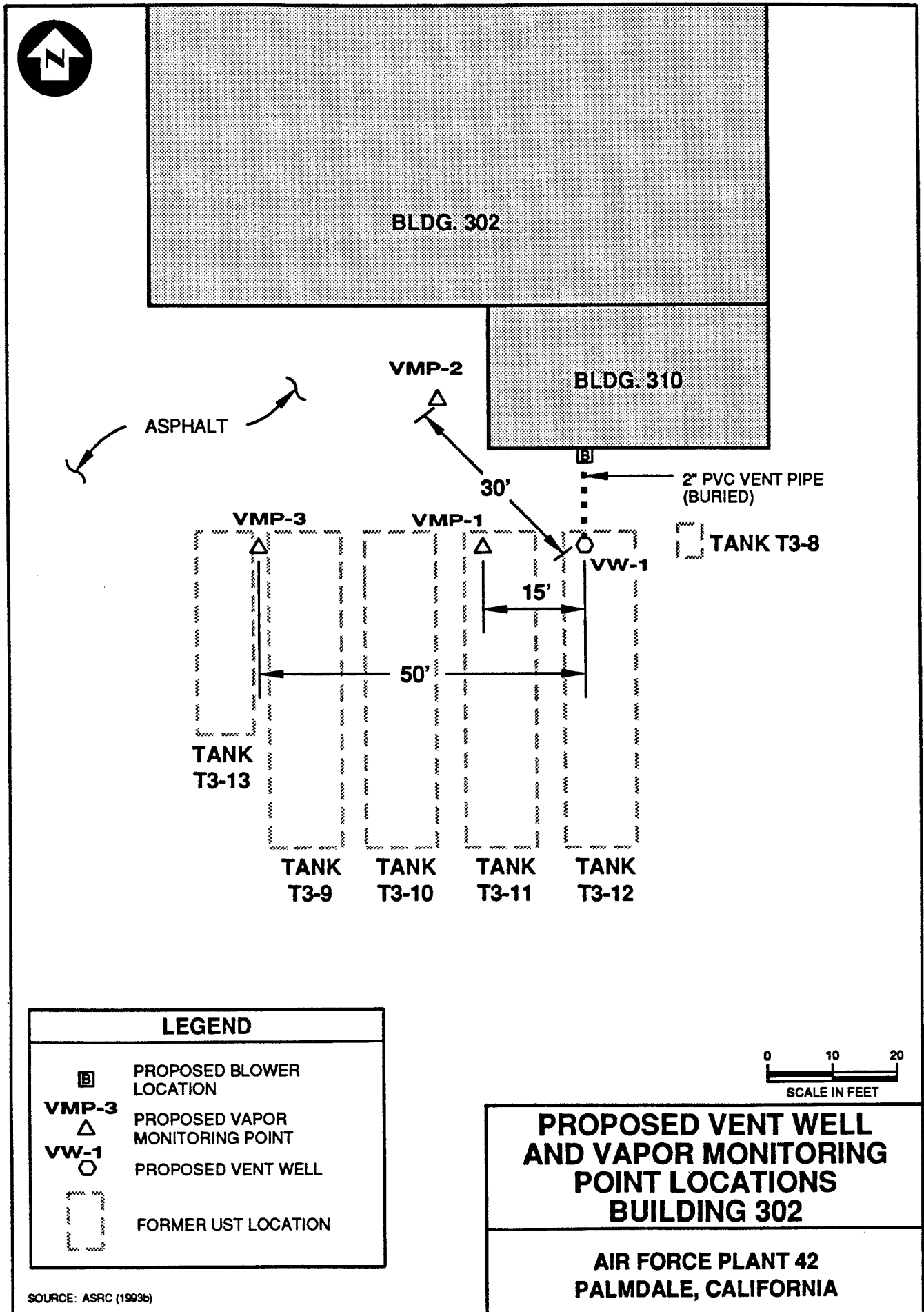

LEGEND	
	PROPOSED BLOWER LOCATION
<b>VMP-3</b> 	PROPOSED VAPOR MONITORING POINT
<b>VW-1</b> 	PROPOSED VENT WELL
	FORMER UST LOCATION



**PROPOSED VENT WELL AND VAPOR MONITORING POINT LOCATIONS BUILDING 302**

**AIR FORCE PLANT 42 PALMDALE, CALIFORNIA**

SOURCE: ASRC (1993b)

FIGURE 3.3

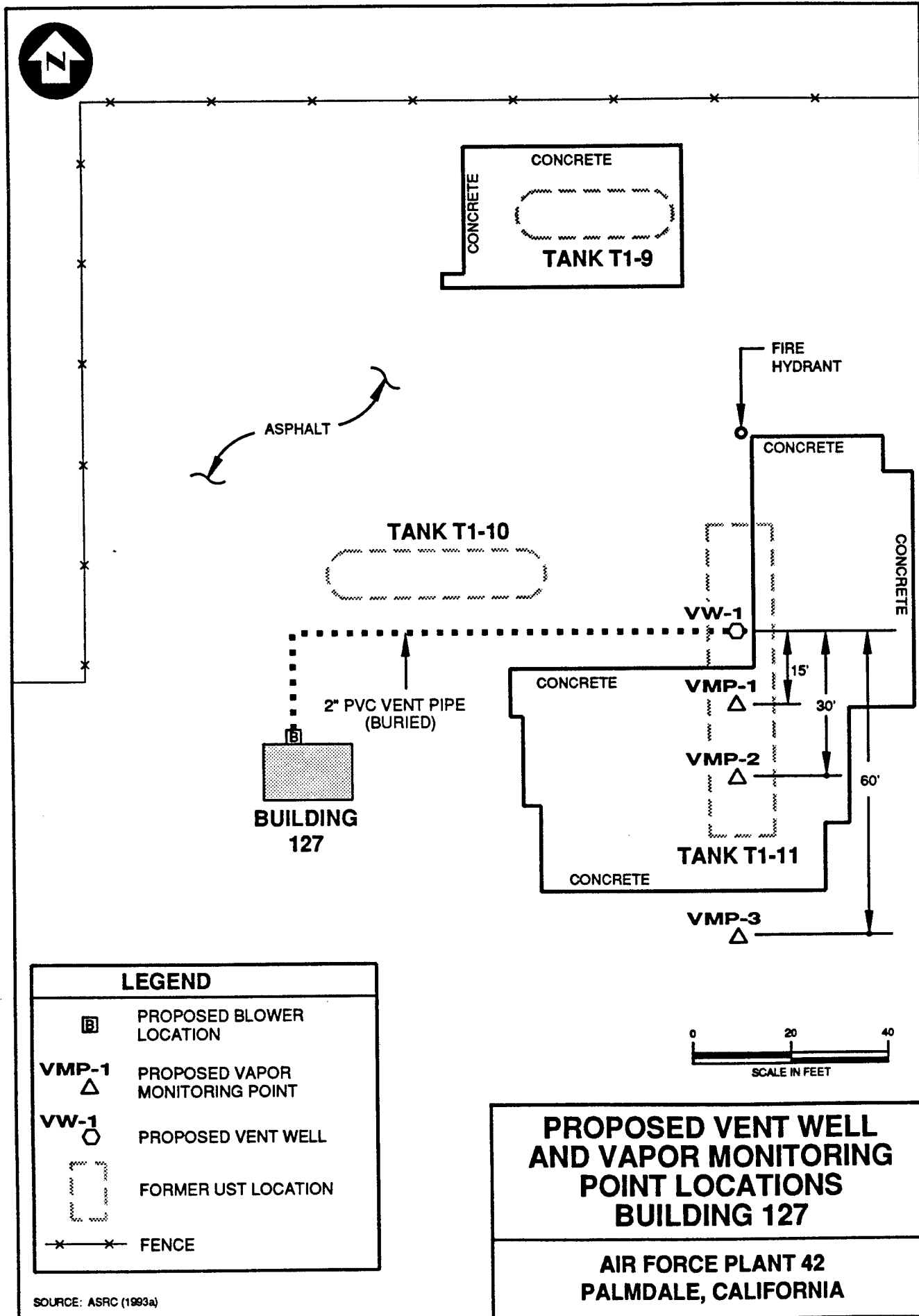

SOURCE: ASRC (1993a)

REV. 2 C272-22.DWG 04/12/94

ENGINEERING-SCIENCE, INC.

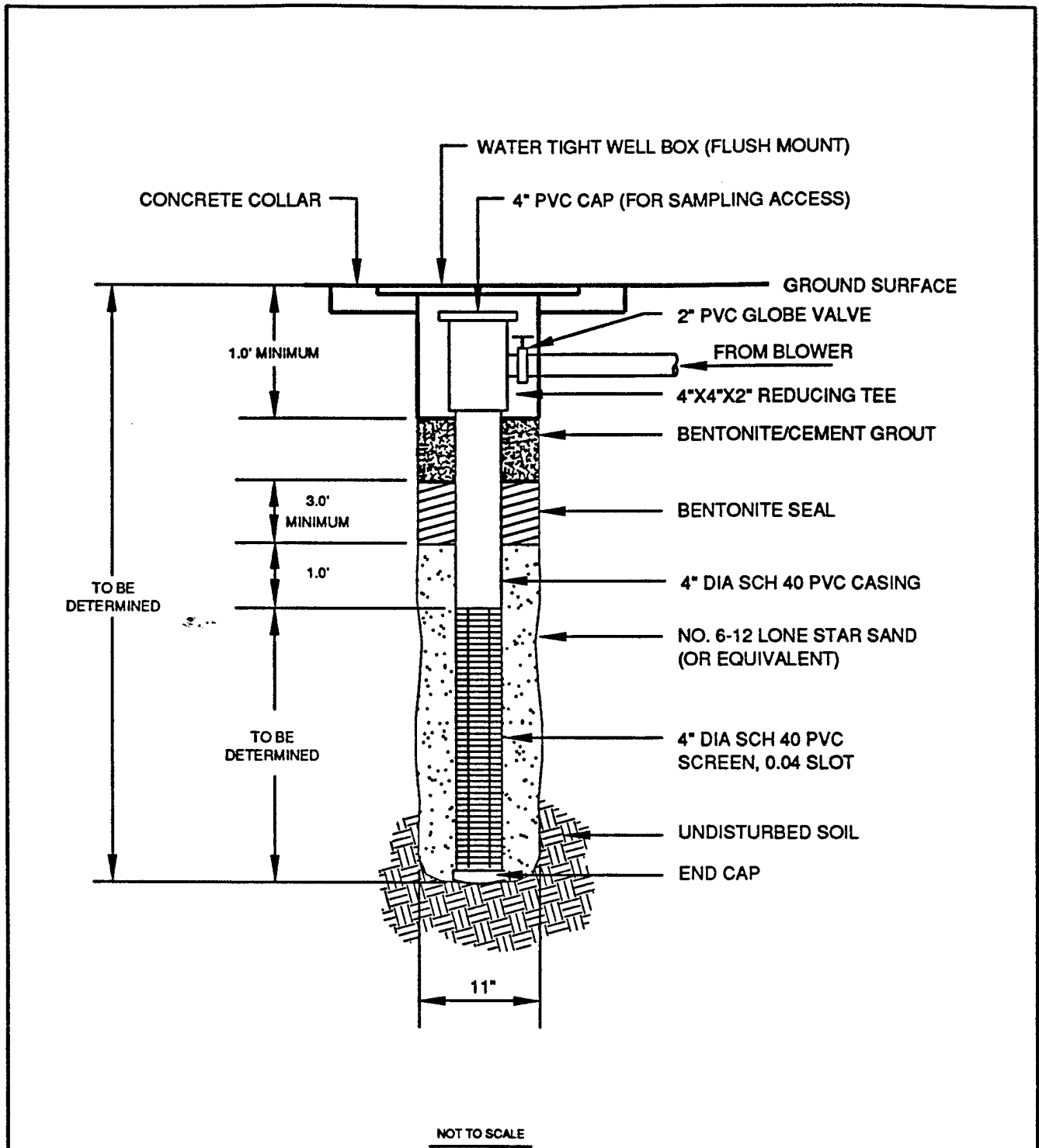

NOTE: DEPTH OF SCREENED INTERVAL WILL BE NEAR THE BASE OF CONTAMINATION AS DETERMINED IN THE FIELD.

**VENTING WELL  
CONSTRUCTION DIAGRAM  
(TYPICAL)**

**AIR FORCE PLANT 42  
PALMDALE, CALIFORNIA**

Flush-threaded PVC casing and screen will be used with no organic solvents or glues. The filter pack will be clean Lone Star sand with a 6-12 grain size (or equivalent) and will be placed in the annular space of the screened interval. A 3-foot layer of bentonite will be placed directly over the filter pack. The remainder of the annular space, except for a 2-foot open area directly below the ground surface, will be filled with a bentonite/cement grout. A complete seal is critical to prevent the short circuiting of air to the surface during injection. Additional details on VW construction are found in Section 4 of the protocol document.

At Building 302 and Building 127, during any extended pilot testing, the blower will be connected to the VW through 2-inch PVC pipe buried approximately 1 foot below the ground surface. At Former Building 147, the blower will be located immediately adjacent to the VW.

### **3.3 Construction of Vapor Monitoring Points**

A typical construction diagram for the multi-depth VMPs at each site is shown in Figure 3.5. Soil-gas oxygen and carbon dioxide concentrations will be monitored via vapor monitoring screens placed at depth intervals which provide good vertical coverage between the ground surface and the base of contamination. Multi-depth monitoring will determine the concentration of oxygen across the entire soil profile and will be used to calculate oxygen-utilization rates and fuel biodegradation rates at all monitored depths.

The annular space between the vapor monitoring screen filter packs will be sealed with bentonite to isolate the monitoring intervals. As with the central VW, several inches of bentonite pellets will be used to shield the filter pack intervals from rapid infiltration of bentonite slurry additions. At the innermost vapor monitoring point (VMP-1), thermocouples will be installed at the same depths as the deepest and shallowest screens to measure soil temperature. Additional details on VMP construction are found in Section 4 of the protocol document.

### **3.4 Handling of Drill Cuttings and Asphalt Debris**

All drill cuttings will be gathered after each borehole is drilled and containerized at each site in labelled U.S. DOT-approved 55 gallon drums. Asphalt debris removed during subsurface trenching operations will be placed on wooden pallets at the site. These soils and debris will be handled and disposed by Pacifica Services, Inc., the operations and maintenance contractor for AFP 42. No drums or asphalt debris will be transported off site by ES or the drilling contractor.

### **3.5 Soil and Soil-Gas Sampling**

#### **3.5.1 Soil Sampling**

Three soil samples will be collected from each site during the installation of the central VW and VMPs. One sample will be collected from the interval of highest apparent contamination in the central VW boring, and one sample will be collected from the interval of highest apparent contamination in each of the two innermost borings

FIGURE 3.5

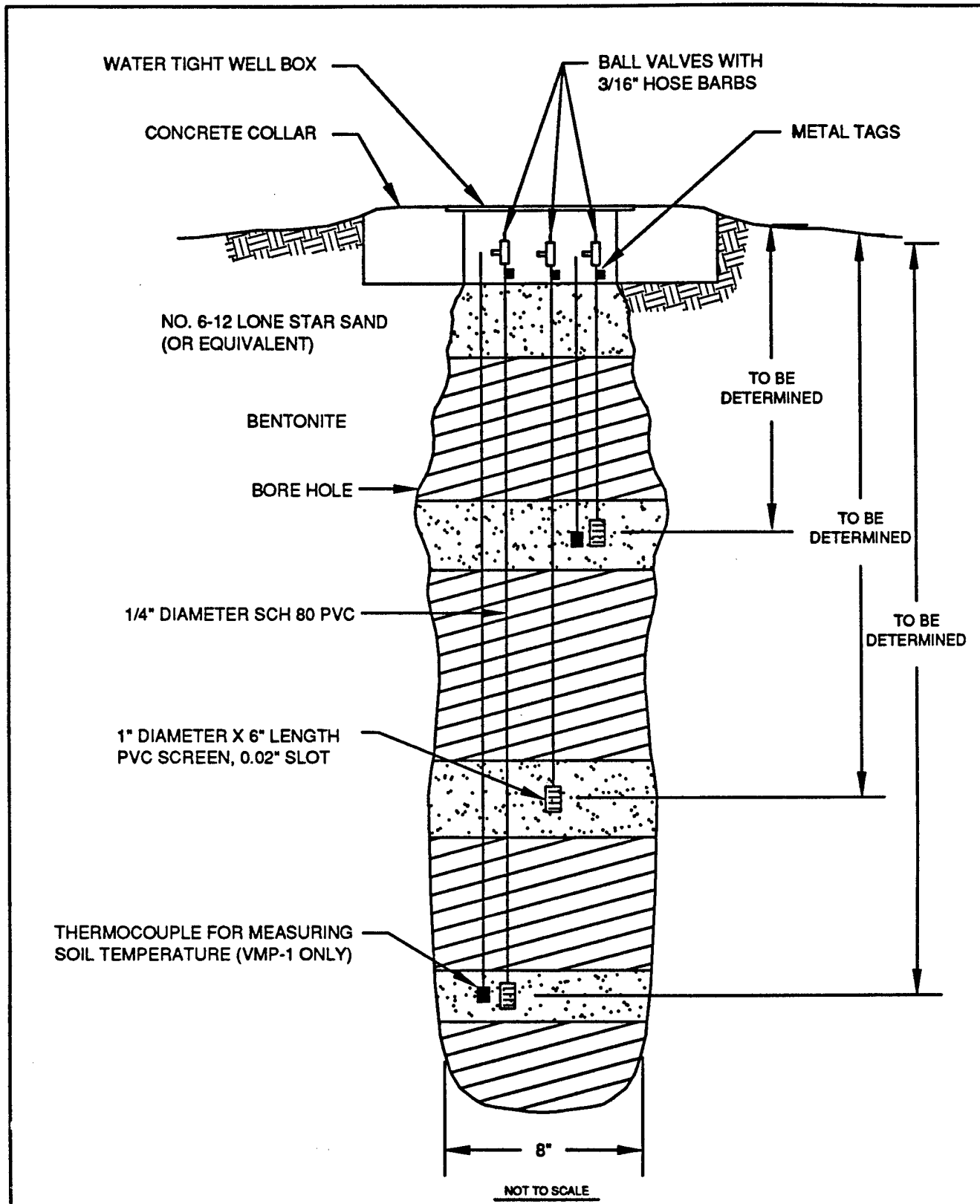

**VAPOR MONITORING POINT  
CONSTRUCTION DIAGRAM  
(TYPICAL)**

**AIR FORCE PLANT 42  
PALMDALE, CALIFORNIA**

NOTE: AN ADDITIONAL VMP SCREEN MAY BE INSTALLED NEAR THE BASE OF CONTAMINATION (AS DETERMINED IN THE FIELD).

(VMP-1 and VMP-2). Soil samples will be analyzed for individual fuel types (fuel scan analysis) using EPA Method modified 8015, benzene, toluene, ethylbenzene, and xylenes (BTEX), moisture content, pH, grain-size distribution, total alkalinity, iron, and nutrients including total Kjeldahl nitrogen (TKN) and total phosphorus. Additional soil samples will be collected at the background VMP and analyzed for TKN to help characterize the non-contaminated, baseline soil nutrient conditions.

Soil samples will be collected using a split-spoon sampler containing brass tube liners. Soil samples collected in the brass tubes will be immediately trimmed and the ends sealed with Teflon<sup>®</sup> fabric held in place by plastic caps. Soil samples collected for inorganic and physical parameters analysis will be collected in brass tubes or placed in other appropriate sample containers. Soil samples will be labeled following the nomenclature specified in Section 5.5 of the protocol document, wrapped in plastic, and placed in an ice chest for shipment. A completed chain-of-custody record form will accompany the ice chest, which will be shipped for analysis to PACE Inc. in Huntington Beach, California, which has been audited by the U.S. Air Force and which meets all quality assurance/quality control and certification requirements for the State of California.

A GasTech<sup>™</sup> Total Hydrocarbon Vapor Analyzer (THVA) will be used to collect field OVA readings of soil sample headspace. This platinum catalyst combustion detector is calibrated with hexane, which provides a conservative reading representative of total petroleum hydrocarbon vapors present. A 100 ppmv OVA reading of the headspace will be the criterion used in determining whether soils are potentially contaminated.

### **3.5.2 Soil-Gas Sampling**

During the pilot test at each site, initial and final soil-gas samples will be collected in Summa<sup>®</sup> canisters from the central VW (VW-1) and the VMPs closest to and furthest from the central VW (VMP-1 and VMP-3). These soil-gas samples will be used to determine the reduction in BTEX and total volatile hydrocarbons over the one-year pilot test period.

Soil-gas samples will be placed in an ice chest and packed to prevent excessive movement during shipment. They will not be sent on ice in order to prevent condensation of hydrocarbons. A completed chain-of-custody record form will accompany the ice chest, which will be shipped to the Air Toxics Ltd. laboratory in Folsom, California for analysis. Samples will be analyzed for BTEX and total volatile hydrocarbons (TVH) using EPA Method TO-3.

### **3.6 Blower System**

A 3.0-horsepower, portable, positive displacement blower capable of injecting air at approximately 30 standard cubic feet per minute (scfm) at 4 psi (110 inches H<sub>2</sub>O) will be used to conduct the initial air permeability (AP) test at each site. Figure 3.6 is a schematic of a typical air injection system used for pilot testing. The maximum power requirement anticipated for pilot testing is 230-volt, single-phase, 30-amp service.

FIGURE 3.6

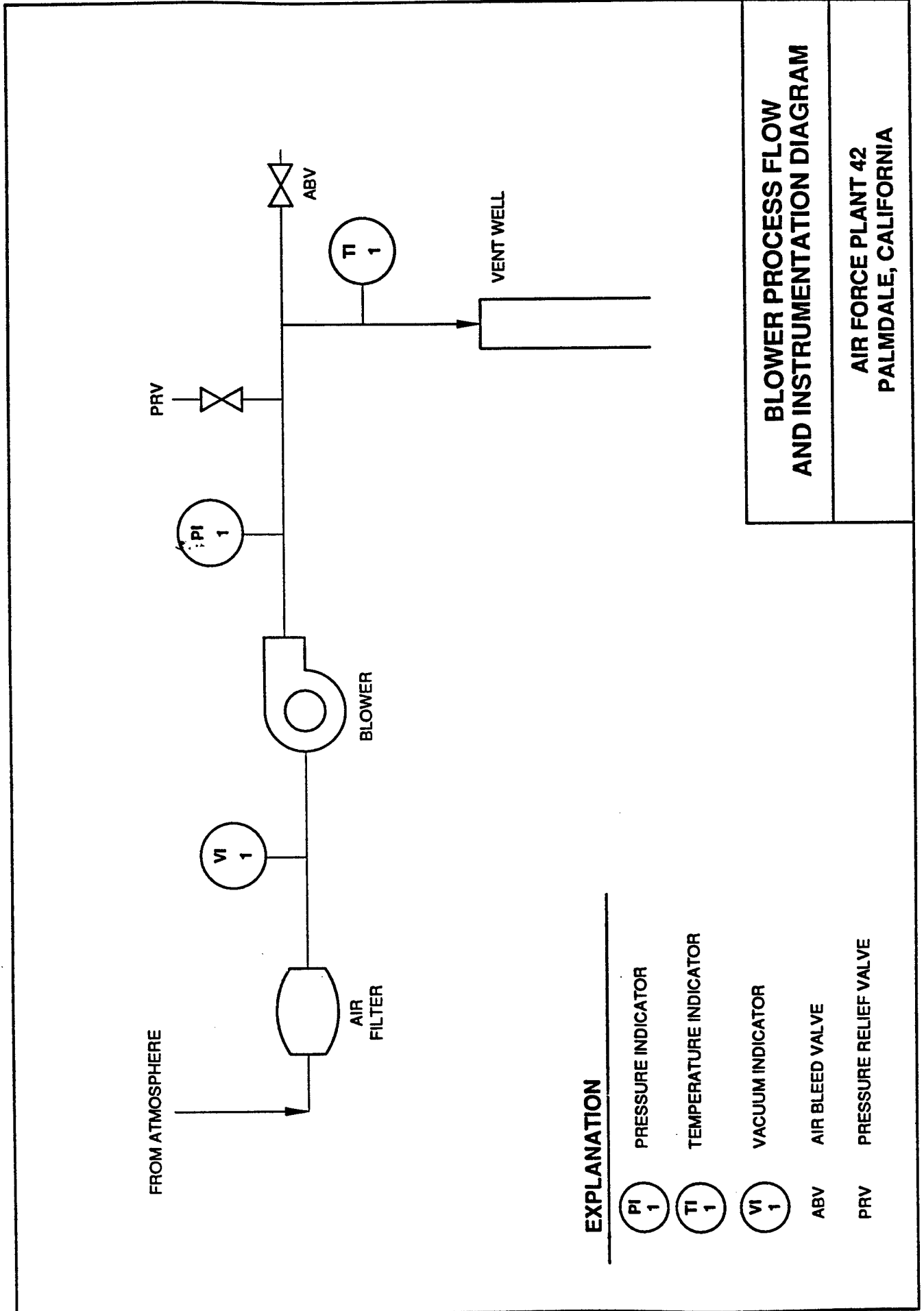

**EXPLANATION**

PI 1 PRESSURE INDICATOR

TI 1 TEMPERATURE INDICATOR

VI 1 VACUUM INDICATOR

ABV AIR BLEED VALVE

PRV PRESSURE RELIEF VALVE

**BLOWER PROCESS FLOW AND INSTRUMENTATION DIAGRAM**

**AIR FORCE PLANT 42  
PALMDALE, CALIFORNIA**

Additional details on power supply requirements are described in Section 5.0, Base Support Requirements.

### **3.7 *In Situ* Respiration Tests**

An *in situ* respiration (ISR) test will be performed at each site during the initial pilot test and additional ISR tests will be performed after 6 and 12 months of extended (one-year) pilot testing. The objective of the initial ISR test is to determine the rate at which native soil microorganisms will biodegrade the TPH and BTEX contamination in the soil. The objective of the follow-up ISR tests is to monitor the long-term performance of the bioventing system.

During the initial pilot test, ISR tests will be performed at the VMPs where biodegradation is indicated by initially low oxygen levels and elevated carbon dioxide levels in the soil gas. A mixture of air (20.8 percent oxygen) and 2 to 4 percent helium will be injected into these VMPs for approximately 20 hours to oxygenate local contaminated soils. At the end of the 20-hour period, the air/helium supply will be cut off and oxygen, carbon dioxide, total volatile hydrocarbons (TVH), and helium levels will be monitored for the following 48 to 72 hours. The decline in oxygen levels over time will be used to estimate rates of bacterial degradation of fuel residuals. Helium, an inert gas, will be used as a tracer gas and monitored to identify possible system leaks or short circuits to the surface. Additional details on ISR testing are found in Section 5.7 of the protocol document.

During the long-term (one-year) pilot test, ISR tests will also be performed by temporarily shutting off the blower and monitoring oxygen and carbon dioxide levels over time. Data collected will be similarly used to estimate rates of bacterial degradation of fuel residuals.

### **3.8 Air Permeability Tests**

The objective of the air permeability (AP) test is to determine the extent of the subsurface which can be oxygenated using one air injection unit. Air will be injected into the 4-inch diameter central VW at each site using the portable blower unit, and the pressure response will be measured at each VMP with differential pressure gauges to determine the region influenced by the unit. Oxygen will also be monitored in the VMPs to ascertain that oxygen levels in the soil increase as a result of air injection. One AP test lasting approximately 8 hours will be conducted at each site chosen for pilot testing.

Additional details on the AP test are found in Section 5.6 of the protocol document.

### **3.9 Potential Air Emissions**

The long-term potential for atmospheric air emissions during the extended (one-year) pilot test is very low since the initial air injection will displace the highest concentrations of volatile organics from the soil. Because horizontal permeability is generally greater than vertical permeability, the injected air will tend to move outward rather than upward. As any accumulated hydrocarbon vapors in the soil move slowly outward from the air injection point, they will be biodegraded as they move horizontally through the soil.

Because a plastic liner was placed in the bottom of excavations at all three sites before backfilling, the potential for vertical migration is significantly reduced. Additionally, test sites at Building 302 and Building 127 are paved with asphalt, which will significantly reduce or effectively eliminate the potential for air emissions for any pilot tests conducted at those sites.

### **3.10 Installation of Extended Bioventing Pilot Test Systems**

An extended (one-year) bioventing pilot test system will be implemented if the initial pilot test successfully demonstrates the feasibility of providing oxygen throughout the contaminated soil profile. This one year of continuous air injection will determine the long-term radius of influence, and the effect of time, available nutrients, and changing temperatures on fuel biodegradation rates.

A fixed Gast™ regenerative blower unit, sized appropriately for each site, will be installed as part of this extended pilot test system. The blower will be housed in a small shed to provide protection from the weather and to minimize noise. This small "doghouse" will be located in a low-traffic area. Base personnel are required to check the blower systems once each week to ensure that they are operating, change filters as needed, and to record air injection pressures and temperatures. ES will provide a maintenance procedures manual, data collection sheets, and a brief training session.

The systems will be in operation for one year, and ES personnel will monitor them biannually, scheduled for November 1994 and May 1995. This biannual monitoring will consist of ISR tests at each site to monitor the long-term performance of the bioventing systems. At the end of the one-year test period, subsurface soil samples will be collected and analyzed at locations as close as possible to the original VW/VMP soil sample locations at each site. Additionally, at the end of the one-year test period, soil-gas samples will be collected and analyzed from the same VMP screens sampled during the initial pilot test. These soil and soil-gas samples will be used to assess the degree of remediation during the first year of *in situ* treatment.

#### 4.0 EXCEPTIONS TO PROTOCOL PROCEDURES

The procedures that will be used at each site to construct wells, measure air permeability of the soil, and conduct the *in situ* respiration tests are described in Section 4 and 5 of the protocol document. No significant exceptions to the protocol are anticipated.

## 5.0 BASE SUPPORT REQUIREMENTS

The following base support is needed prior to the arrival of a driller and the ES test team:

- Obtain all necessary regulatory permits for the vent well and vapor monitoring points, and any air permits needed for pilot test approval.
- Obtain any required base digging permits or permits to install wells.
- Obtain the required permits so that photographs may be taken at each site.
- At the two primary sites (former Building 147 and Building 302), installation of a 230V/single phase/30 amp electrical service, which meets any locally or Air Force required electrical or fire safety codes. The electrical service must include an on-off switch, one 230V receptacle (NEMA type L630), and at least one 110V receptacle. The electrical service must be within 20 feet of the proposed blower location at the two sites (Figures 3.1 and 3.2). At Former Building 147, the electrical service must be installed on the south side of the Site 1 fence so that entrance into Site 1 is not required.

Although installation of power should not be performed initially at the alternate site (Building 127), provisions should be made in contractual modifications with the Site 1 tenant (Rockwell) so that power could be installed within three weeks of notification.

- Provide any paperwork required to obtain gate passes and security badges for approximately three ES employees and one driller. Vehicle passes will be needed for two trucks and a drill rig. The passes must be valid for the expected duration of drilling operations and the initial pilot tests (about four weeks).
- Provide wooden pallets for storing asphalt debris and the 55-gallon drums which will hold drill cuttings.
- Arrange for the pick up and disposal of the drums and asphalt debris by Pacifica Services, Inc. at the completion of drilling operations.

During the initial pilot tests, the 6-month tests, and one-year tests (two week periods each), the following additional base support is required:

- Access to a telephone in a building located as near to each site as practical.
- 24-hour site access and 24-hour access to 110V electrical service.
- The use of a fax machine for transmitting test results.

During the one-year pilot test period, the following additional base support is required:

- Base personnel are required to check the blower systems once each week to ensure that they are all operating, change filters as needed, and to record air injection pressures and temperatures. ES will provide a maintenance procedures manual, data collection sheets, and a brief training session.

- If any blowers stop working, notify: Mr. Fred Stanin or Mr. Michael Phelps, ES-Alameda, (510) 769-0100; or Mr. Doug Downey, ES-Denver (303) 831-8100; or Lt. Maryann Jenner of AFCEE, (210) 536-4364.

## 6.0 PROJECT SCHEDULE

The following schedule is contingent upon timely approval of this pilot test work plan.

<u>Event</u>	<u>Date</u>
Initial Base Meeting	23-24 February 1994
Pilot Test Work Plan to AFCEE/AFP 42	13 April 1994
Approval to Proceed	6 May 1994
Begin VW and VMP construction	16 May 1994
Begin Initial Pilot Tests	23 May 1994
Interim Results Report	August 1994
Biannual Respiration Tests	November 1994
Final Respiration Tests and Soil Sampling	May 1995

## 7.0 POINTS OF CONTACT

Daryl K. Vetsch  
EMVR. Det. 1, Aeronautical Systems Center  
USAF Plant 42  
2503 East Avenue P  
Palmdale, CA 93550-1296  
(805) 272-6710  
Fax (805) 273-7558

Lt. Maryann M. Jenner  
AFCEE/ERT  
8001 Arnold Drive (Bldg 642)  
Brooks AFB, TX 78235-5357  
(210) 536-4364  
Fax (210) 536-4330

Mr. Doug Downey  
Engineering-Science, Inc.  
1700 Broadway, Suite 900  
Denver, CO 80290  
(303) 831-8100  
Fax (303) 831-8208

Mr. Fred Stanin  
Mr. Michael Phelps  
Engineering-Science, Inc.  
1301 Marina Village Parkway, Suite 200  
Alameda, CA 94501  
(510) 769-0100  
Fax (510) 769-9244

## 8.0 REFERENCES

- ASRC Contracting Company, Inc., 1993a, Closure Report, Site 1, Underground Storage Tanks, U.S. Air Force Plant 42, Los Angeles County Department of Public Works Closure Permit 44513, File 16298
- ASRC Contracting Company, Inc., 1993b, Closure Report, Underground Storage Tanks, U.S. Air Force Plant 42, Los Angeles County Department of Public Works Closure Permits 44497, 44499, 67321, and 61242, Files 3658 and 16299
- CH2M Hill, 1983, Installation Restoration Program Records Search for Air Force Plant 42, California
- Engineering-Science, Inc., 1983, Final Report, Installation Restoration Program, Phase II - Confirmation. June
- Engineering-Science, Inc., 1988, Installation Restoration Program Phase II and IVA (Stage 2) - RI/FS Work Plan, U.S. Air Force Plant No. 42, Palmdale, California
- Hinchee et al. 1992, Test Plan and Technical Protocol for a Field Treatability Test for Bioventing, U.S. Air Force Center for Environmental Excellence (AFCEE). January
- Hargis & Associates, Inc., 1989, Plan of Action for the Underground Leak Detector Program, U.S. Air Force Plant 42, Palmdale, California: submitted to Air Force Systems Command, Wright-Patterson Air Force Base.
- Montgomery, James M., 1992, Final Field Investigation Report, Fire Fighting Training Facility Groundwater Monitoring Well Installation, August
- U.S. Geological Survey, 1967, Water Resources of the Antelope Valley-East Kern Water Agency Area, California. USGS Water Resources Division. Open-File Report.