

# LOAN DOCUMENT

PHOTOGRAPH THIS SHEET

0

DTIC ACCESSION NUMBER

LEVEL

INVENTORY

2 Parts

Bioventing Pilot Test Work Plan for ...

DOCUMENT IDENTIFICATION

Jan 93

**DISTRIBUTION STATEMENT A**  
Approved for Public Release  
Distribution Unlimited

DISTRIBUTION STATEMENT

|                    |                             |
|--------------------|-----------------------------|
| ACCESSION FOR      |                             |
| NTIS               | GRAM                        |
| DTIC               | TRAC                        |
| UNANNOUNCED        |                             |
| JUSTIFICATION      |                             |
| BY                 |                             |
| DISTRIBUTION/      |                             |
| AVAILABILITY CODES |                             |
| DISTRIBUTION       | AVAILABILITY AND/OR SPECIAL |
| A-1                |                             |

DISTRIBUTION STAMP

|  |
|--|
|  |
|--|

DATE ACCESSIONED

|  |
|--|
|  |
|--|

DATE RETURNED

|  |
|--|
|  |
|--|

REGISTERED OR CERTIFIED NUMBER

20001214 093

DATE RECEIVED IN DTIC

PHOTOGRAPH THIS SHEET AND RETURN TO DTIC-FDAC

H  
A  
N  
D  
L  
E  
  
W  
I  
T  
H  
  
C  
A  
R  
E

# **PART I**

**Bioventing Pilot Test Work Plan for  
Fire Protection Training Area Site FT-03  
Charleston AFB, South Carolina**

# **PART II**

**Draft Interim Pilot Test Results Report for  
Fire Protection Training Area Site FT-03  
Charleston AFB, South Carolina**

Prepared For

**Air Force Center for Environmental Excellence  
Brooks AFB, Texas**

and

**Headquarters 437 Airlift Wing (AMC)  
Charleston AFB, South Carolina**

**ES**

**Engineering-Science, Inc.**

**January 1993**

1700 BROADWAY, SUITE 900  
DENVER, COLORADO 80290

**ES ENGINEERING-SCIENCE**

*AGM01-03-0530*

### DEFENSE TECHNICAL INFORMATION CENTER REQUEST FOR SCIENTIFIC AND TECHNICAL REPORTS

Title AFCEE Collection

**1. Report Availability** (Please check one box)

- This report is available. Complete sections 2a - 2f.
- This report is not available. Complete section 3.

**2a. Number of Copies Forwarded**

each

**2b. Forwarding Date**

July/2000

**2c. Distribution Statement** (Please check ONE box)

*DoD Directive 5230.24, "Distribution Statements on Technical Documents," 18 Mar 87, contains seven distribution statements, as described briefly below. Technical documents MUST be assigned a distribution statement.*

- DISTRIBUTION STATEMENT A:** Approved for public release. Distribution is unlimited.
- DISTRIBUTION STATEMENT B:** Distribution authorized to U.S. Government Agencies only.
- DISTRIBUTION STATEMENT C:** Distribution authorized to U.S. Government Agencies and their contractors.
- DISTRIBUTION STATEMENT D:** Distribution authorized to U.S. Department of Defense (DoD) and U.S. DoD contractors only.
- DISTRIBUTION STATEMENT E:** Distribution authorized to U.S. Department of Defense (DoD) components only.
- DISTRIBUTION STATEMENT F:** Further dissemination only as directed by the controlling DoD office indicated below or by higher authority.
- DISTRIBUTION STATEMENT X:** Distribution authorized to U.S. Government agencies and private individuals or enterprises eligible to obtain export-controlled technical data in accordance with DoD Directive 5230.25, Withholding of Unclassified Technical Data from Public Disclosure, 6 Nov 84.

**2d. Reason For the Above Distribution Statement** (in accordance with DoD Directive 5230.24)

**2e. Controlling Office**

HQ AFCEE

**2f. Date of Distribution Statement Determination**

15 Nov 2000

**3. This report is NOT forwarded for the following reasons.** (Please check appropriate box)

- It was previously forwarded to DTIC on \_\_\_\_\_ (date) and the AD number is \_\_\_\_\_
- It will be published at a later date. Enter approximate date if known. \_\_\_\_\_
- In accordance with the provisions of DoD Directive 3200.12, the requested document is not supplied because: \_\_\_\_\_

Print or Type Name

Laura Peña

Signature

Laura Peña

Telephone

210-536-1431

(For DTIC Use Only)

AQ Number M01-03-0530

**PART I**

**BIOVENTING PILOT TEST WORK PLAN FOR  
FIRE PROTECTION TRAINING AREA SITE FT-03  
CHARLESTON AFB, SOUTH CAROLINA**

Prepared for:

**AIR FORCE CENTER FOR ENVIRONMENTAL EXCELLENCE  
BROOKS AFB, TEXAS**

and

**HEADQUARTERS 437 AIRLIFT WING (AMC)  
CHARLESTON AFB, SOUTH CAROLINA**

September 1992

Prepared by:

**Engineering-Science, Inc.  
1700 Broadway, Suite 900  
Denver, Colorado**

## CONTENTS

|   | <u>Page</u> |
|---|-------------|
| 1.0 Introduction.....   | I-1         |
| 2.0 Site Description.....                                     | I-1         |
| 2.1 Site Location and History.....                            | I-2         |
| 2.2 Previous Investigations.....                              | I-2         |
| 2.3 Site Geology.....   | I-5         |
| 2.4 Site Contaminants.....                                    | I-5         |
| 3.0 Site Specific Activities.....                             | I-5         |
| 3.1 Bioventing Test Design for Site FT-03.....                | I-6         |
| 3.2 Handling of Soil Boring Cuttings and Excavated Soils..... | I-9         |
| 3.3 Soil Sampling.....  | I-9         |
| 3.4 Blower System.....  | I-12        |
| 3.5 <i>In Situ</i> Respiration Test.....                      | I-12        |
| 3.6 Air Permeability Test.....                                | I-12        |
| 4.0 Exceptions to Protocol Procedures.....                    | I-15        |
| 5.0 Base Support Requirements.....                            | I-15        |
| 5.1 Test Preparation.....                                     | I-15        |
| 5.2 Permit Requirements.....                                  | I-16        |
| 6.0 Project Schedule.....                                     | I-16        |
| 7.0 Points of Contact.....                                    | I-17        |
| 8.0 References.....   | I-17        |

## FIGURES

| <u>No.</u> | <u>Title</u>   | <u>Page</u> |
|------------|--|-------------|
| 2.1        | Site FT-03 Location Map.....                                 | I-3         |
| 2.2        | Existing Monitoring Well Locations.....                      | I-4         |
| 3.1        | Proposed Injection Well/Monitoring Point Locations.....      | I-7         |
| 3.2        | Monitoring Well 3-7 Construction.....                        | I-8         |
| 3.3        | Injection Vent Well and Trench Construction.....             | I-10        |
| 3.4        | Typical Monitoring Point Construction Detail.....            | I-11        |
| 3.5        | Blower System Instrumentation Diagram For Air Injection..... | I-13        |
| 3.6        | Electrical Diagram For Blower System.....                    | I-14        |

# **BIOVENTING PILOT TEST WORK PLAN FOR FIRE PROTECTION TRAINING AREA SITE FT-03 CHARLESTON AFB, SOUTH CAROLINA**

## **1.0 INTRODUCTION**

This site-specific work plan presents the scope of a bioventing pilot test for *in situ* treatment of fuel contaminated soils at the Fire Protection Training Area designated as Site FT-03, Charleston Air Force Base (AFB), South Carolina. The proposed pilot test has three primary objectives: 1) to assess the potential for supplying oxygen throughout the contaminated soil depth, 2) to determine the rate at which indigenous microorganisms will degrade the fuel hydrocarbons in the soil when stimulated by oxygen-rich soil gas, and 3) to evaluate the potential for sustaining these rates of biodegradation until fuel contamination is remediated to concentrations below regulatory standards.

If bioventing proves to be an effective remedial technology for this site, pilot test data will be used to design a full-scale remediation system and to estimate the time required for remediating soils to regulatory standards. An added benefit expected from the pilot testing at Site FT-03 is that a significant amount of the fuel contamination should be biodegraded during the 1-year pilot test, since the testing will take place within the most contaminated soils that have been detected on the site.

The pilot test will involve installing one horizontal air injection well and a blower capable of sustaining a flow rate of at least 40 standard cubic feet per minute (scfm). These tests typically produce an effective radius of influence of approximately 20 to 40 feet for a vertical venting well. As is expected at Site FT-03, horizontal venting wells placed in areas with a shallow water table may have smaller effective radii of influence. The design flow rate and actual radius of influence will depend on site-specific soil properties and other factors. Rates of *in situ* fuel biodegradation will be determined at individual soil vapor monitoring points that will be installed around the venting well.

Additional background information on the development and recent success of the bioventing technology is found in the document entitled *Test Plan and Technical Protocol For A Field Treatability Test For Bioventing* (Hinchee et al., 1992). This protocol document is a supplement to the site-specific work plan and also serves as the primary reference for pilot test well designs and detailed test objectives and procedures. Unless otherwise noted, test procedures outlined in the protocol document will be used during the pilot test at Site FT-03.

## **2.0 SITE DESCRIPTION**

### **2.1 Site Location and History**

Site FT-03 is approximately 2 acres in size and is located east of Airport Road at the northeast corner of the Base. The area of concern is located approximately 200 feet from the Base property boundary and about 1,500 feet from off-Base houses. The site is fenced and is surrounded on three sides by woods and on one side by Airport Road. A small, intermittent stream channel is located on the north and east sides of the site (Versar, Inc., 1992). Figure 2.1 shows the location of Site FT-03 with respect to the Base.

Site FT-03 was operated as a Base fire protection and training exercise area from about 1970 until the early 1980s. The former fire training area exists in the form of a circular pit constructed with an earthen berm and a limestone base. A large steel storage tank, used in the training exercises to simulate an aircraft, remains in the pit. According to Base personnel, approximately 300 gallons of JP-4 jet fuel were used to fuel the fire during each training exercise. An average of two training exercises were conducted each month. It is probable that some other industrial flammable wastes may have been burned in the pit. Dry chemicals and various foams were also applied as firefighting agents (Versar, Inc., 1992).

### **2.2 Previous Investigations**

Seven groundwater monitoring wells were installed at Site FT-03 during two phases of remedial investigations executed by Science Applications International Corporation (SAIC) and by Versar, Inc. As referenced in the Phase II Remedial Investigation/Feasibility Study Report, Stage 2 (Versar, Inc., 1992), five of the original wells (3-1 through 3-5) reportedly had submerged well screens during several water level measuring events. Two additional wells (3-6 and 3-7) were installed with screens reportedly above the water table surface. Figure 2.2 shows the locations of all seven monitoring wells at Site FT-03.

Three soil boring samples, four sediment samples, and one surface water sample were collected and analyzed during the first two stages of investigations at Site FT-03 (see Figure 2.2). A soil gas/headspace survey consisting of 79 shallow sampling points was conducted in April 1990 as part of these investigations. The soil gas/headspace survey was performed by advancing shallow soil borings with a hand auger to depths of 2 to 3 feet below ground surface (bgs), followed by field screening of each sample headspace for volatile organic compounds (VOCs) using a portable field flame ionization detector/gas chromatograph (FID/GC) instrument. The headspace analyses were also supplemented by several laboratory-analyzed confirmation samples (Versar, Inc., 1992).

According to the Installation Restoration Program (IRP) Site Contact at Charleston AFB, additional investigations and sampling at Site FT-03 are scheduled for late October 1992. These activities could precede the bioventing pilot test. The design of this test work plan is based solely on site data collected and summarized in previous reports, specifically the Phase II Remedial Investigation/Feasibility Study Report (Versar, Inc., 1992). These data are considered sufficient for designing the bioventing pilot study. Nonetheless, results of the upcoming investigation at Site

Figure 2.1

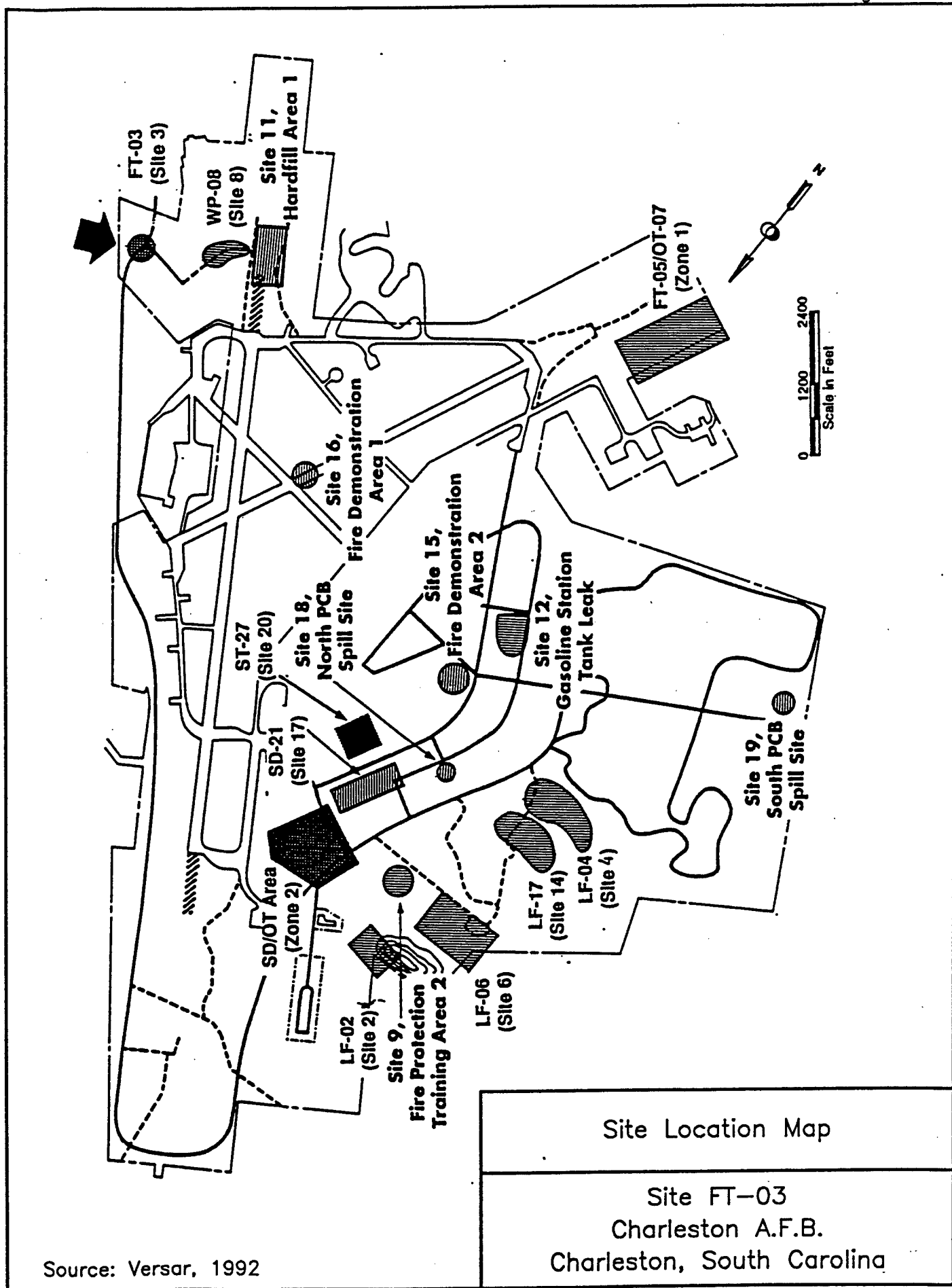

Source: Versar, 1992

Figure 2.2

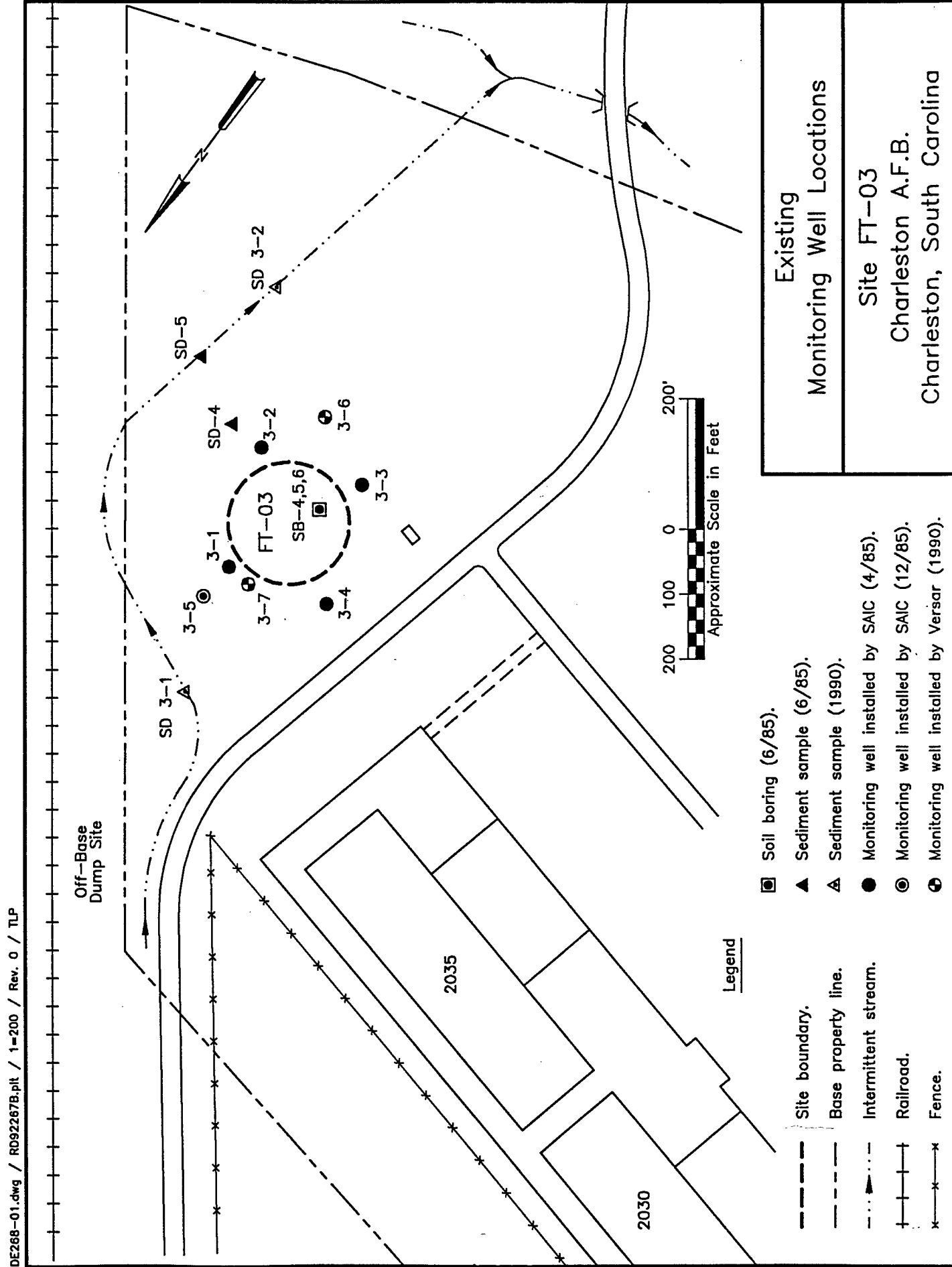

DE268-01.dwg / RD92267B.plt / 1=200 / Rev. 0 / TLP

Off-Base  
Dump Site

2035

2030

Legend

- Site boundary.
- - - Base property line.
- · - · - Intermittent stream.
- + + + Railroad.
- x x x Fence.
- ▣ Soil boring (6/85).
- ▲ Sediment sample (6/85).
- △ Sediment sample (1990).
- Monitoring well installed by SAIC (4/85).
- ⊙ Monitoring well installed by SAIC (12/85).
- ⊕ Monitoring well installed by Versar (1990).



Existing  
Monitoring Well Locations  
Site FT-03  
Charleston A.F.B.  
Charleston, South Carolina

FT-03 will be considered if it is determined that new data collected during the investigation will significantly affect the bioventing pilot test objectives, design, or procedures.

### **2.3 Site Geology**

Charleston AFB is located in the Lower Coastal Plain physiographic province of South Carolina. Sediments beneath the Base are characterized as a thick sequence of interbedded sands, silts, and clays formed by fluvial and marine processes. These interbedded layers are grouped into regional formations and aquifers based on lithologic and water quality characteristics. Surficial soils around the Base are generally sandy and highly permeable at shallow depths, but may contain zones of clay and organic deposits. The area is marked by low geomorphic relief.

The shallow stratigraphy at Site FT-03 consists of sands, silts, and clays of the Ladson Formation to depths ranging from 36 to 58 feet bgs. The Ladson Formation forms the surficial, unconfined aquifer in the vicinity of the Base. Groundwater is encountered at a depth of approximately 4.5 to 6 feet bgs at the site and locally flows south-southeast toward Filbin Creek at an estimated linear velocity of 23 to 59 feet per year. Seasonal water table fluctuations of several feet are common in this area and recharge to the surficial aquifer from precipitation events is rapid.

A 4-inch-diameter horizontal air injection well and four vapor monitoring points will be installed above the water table. Existing groundwater monitoring well 3-7 will be used as one of the vapor monitoring points. Soil vapor monitoring points will be positioned in four locations and at two depths within each location, to study the subsurface oxygen distribution pattern during the pilot test. Because the bioventing technology is applied to the unsaturated soils, this section will primarily address soils above the shallow water table.

### **2.4 Site Contaminants**

The primary contaminants at Site FT-03 are petroleum hydrocarbons, which have been detected in the soils and groundwater at depths ranging from ground surface to about 30 feet bgs. Total recoverable petroleum hydrocarbons (TRPH) maximum concentrations of 7,770 milligrams per kilogram (mg/kg) have been detected in the soils at a depth of 2 to 3 feet at soil sampling point SH3-30 on the north end of the fire pit berm. Soil headspace VOCs were also detected at concentrations of 22 parts per million, volume per volume (ppmv) at this sampling point. Shallow sediment samples also contained TRPH concentrations of 3,310 mg/kg. The VOCs benzene, toluene, ethylbenzene, and total xylenes (BTEX) were detected in both soils and groundwater at the site. Several chlorinated solvents have also been detected in both soils and groundwater. Lead (dissolved and total) has also been detected in groundwater at the site.

## **3.0 SITE-SPECIFIC ACTIVITIES**

The purpose of this section is to describe the proposed location of the central venting well and vapor monitoring points at Site FT-03. Soil sampling procedures and the blower configuration that will be used to inject air (oxygen) into contaminated soils are also discussed in this section. The 4-inch air injection well

will not be completed into the groundwater, and no dewatering will take place during the pilot tests. Pilot test activities will target unsaturated soils remediation. Existing monitoring well 3-7 will be used as a vapor monitoring point. Additionally, existing uncontaminated monitoring wells that have a portion of their screened interval above the water table may be used to measure the composition of background soil gas. If an existing background monitoring well does not meet this criteria, then a background vapor monitoring point will be installed.

### 3.1 Bioventing Test Design For Site FT-03

A general description of criteria for siting a central venting well and vapor monitoring points are included in the attached protocol. Figure 3.1 illustrates the proposed locations of the horizontal air injection well and vapor monitoring points (VMPs) at the site. The horizontal air injection well will be installed in a narrow trench excavated in contaminated soils just above the water table. Wherever possible, the trench will be located in the area of highest surface relief. Orientation of the trench axis is expected to be approximately east-west, perpendicular to groundwater flow. Preliminary intentions are to keep the venting well trench outside of the lowest portions of the circular fire pit because the pit has a limestone base that might hinder excavation and the interior of the pit is poorly drained. The final locations of these wells may vary slightly from the locations shown in Figure 3.1 if significant fuel contamination is not observed in the boring for the first monitoring point.

Based on site investigation data, the central horizontal air injection well should be located in close proximity to existing well 3-7. This area is expected to have an average TRPH concentration exceeding 5,000 mg/kg in unsaturated soils. Existing monitoring well 3-7 will be utilized in addition to the four vapor monitoring points since it reportedly has about 1.5 feet of screen above the water table surface. Soils in this area have the greatest potential of being oxygen depleted (<2%), and increased biological activity should be stimulated by oxygen-rich soil gas ventilation during pilot-test operations.

Considering the shallow depth of contamination in unsaturated soils at this site (< 5 feet bgs), the soil lithology, and the venting well configuration required to accommodate shallow water table conditions, the radius of venting influence around the central air injection well is expected not to exceed 30 feet. A primary concern at this site is possible short-circuiting of injected air to the ground surface, resulting in a loss of the effective radius of venting influence. The installation of a horizontal venting well is expected to minimize this effect and will likely produce better test results than would a vertical venting well.

Four VMPs will be located within a 30-foot radius of the central venting well. Three of the VMPs will be oriented in a straight line and the fourth well will be placed near one end of the trench. An effort will be made to use an existing well to measure background levels of oxygen and carbon dioxide and to determine if natural carbon sources (i.e. organic layers) or mineral reactions are contributing to oxygen uptake during the *in situ* respiration test. Monitoring well 3-5 could be used as a background monitoring point if the screened interval extends several feet above the water table. A schematic of well 3-7 is shown in Figure 3.2. If no suitable

Figure 3.1

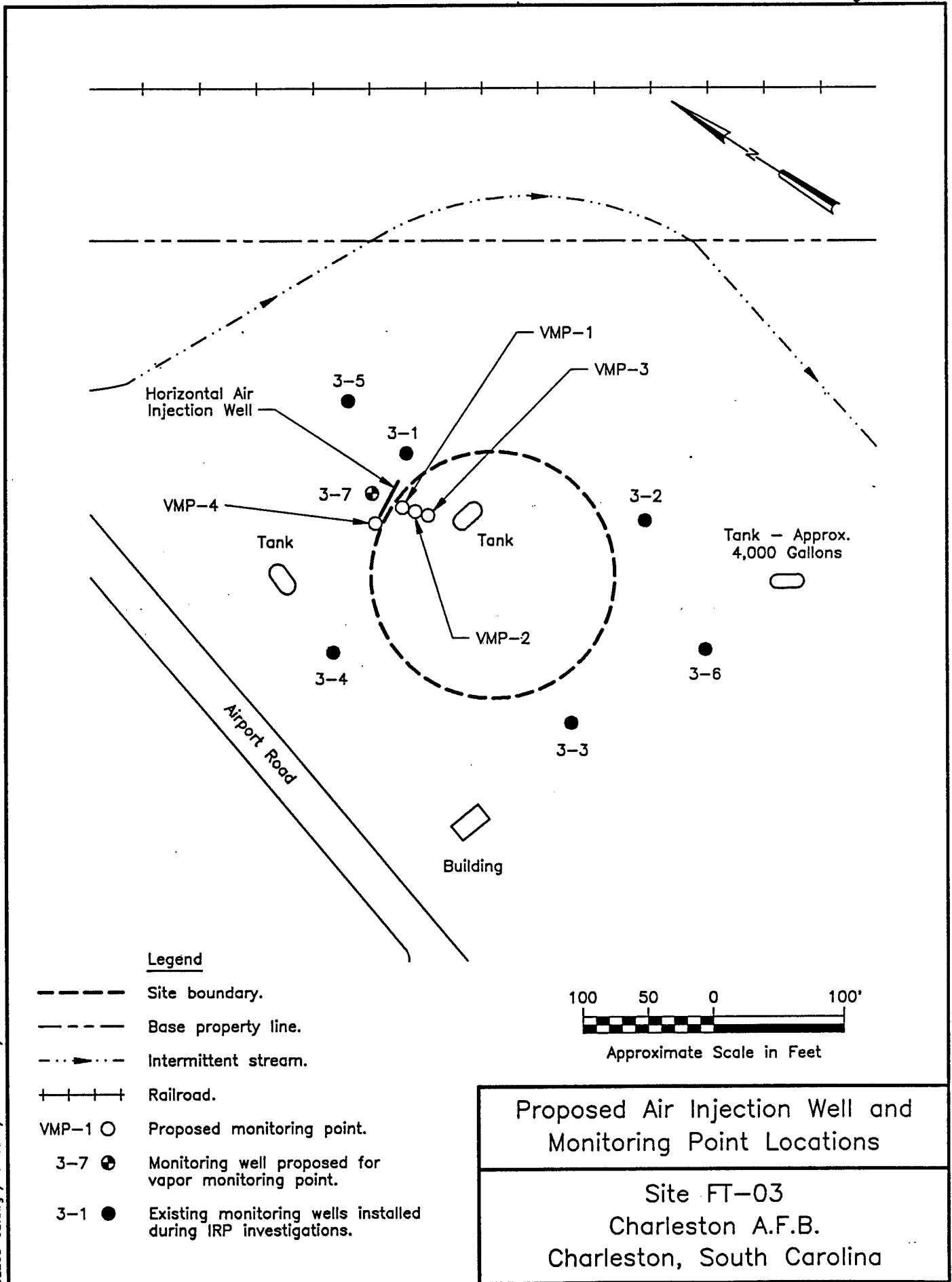

DE268-02.dwg / 1=100 / 1-19-93 / TLP

Figure 3.2

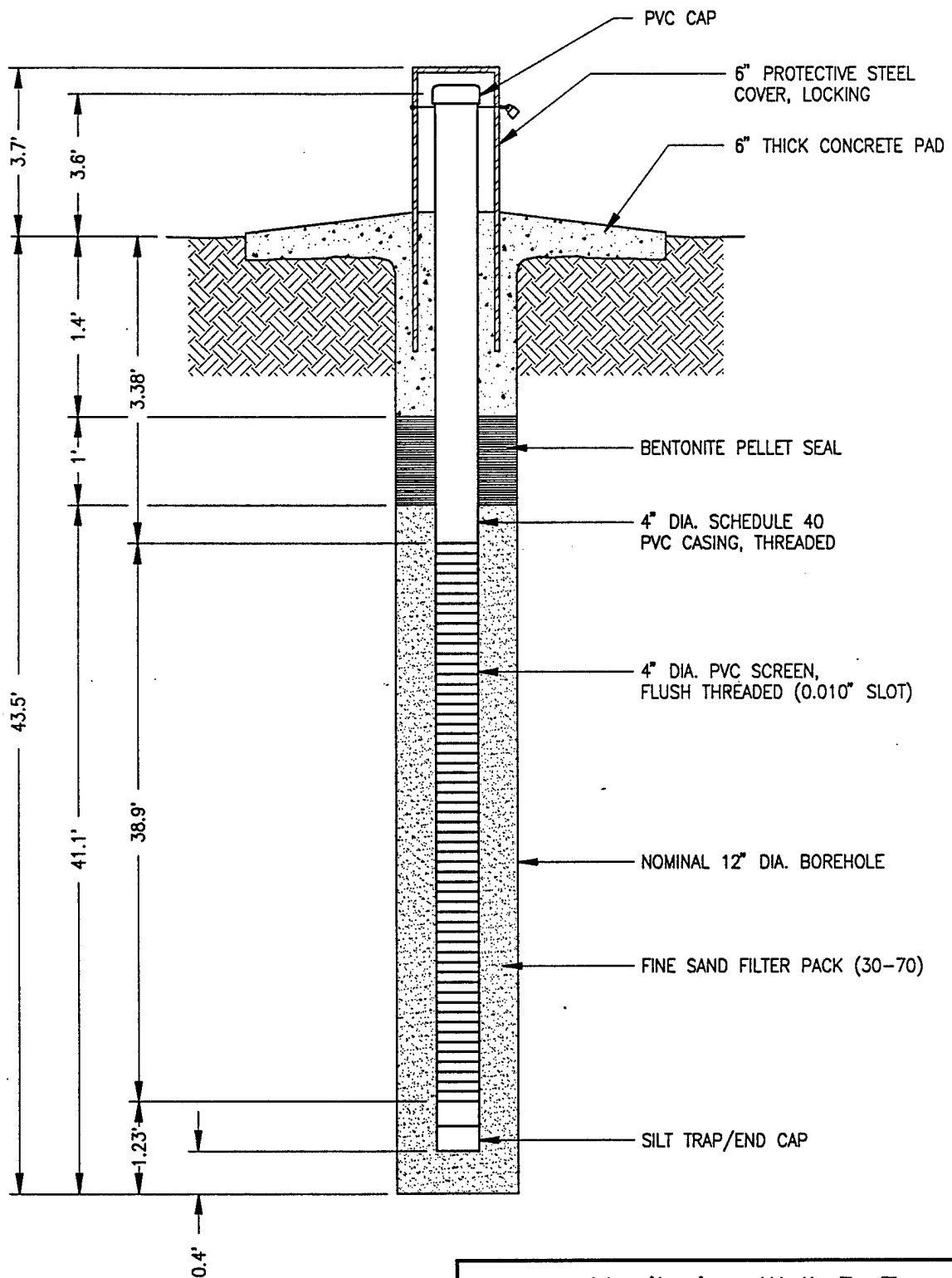

Note: Top of screen is 3.4' below land surface.  
Water table was 5' below land surface  
on 6-26-90.

Monitoring Well 3-7  
Construction

Site FT-03  
Charleston A.F.B.  
Charleston, South Carolina

DE268-07.dwg / RD92267A.plt / 1=1 / Rev. 0 / TLP

existing well is available, a background monitoring point will be constructed. Additional details on the *in situ* respiration test are found in Section 5.7 of the protocol document (Hinchee et al., 1992).

The central horizontal air injection well will be constructed of 4-inch inside-diameter (ID) Schedule 40 polyvinyl chloride (PVC), with 20 feet of 0.03-inch slotted screen set in a narrow trench at approximately 4.5 feet bgs. A 5-foot PVC casing will extend horizontally beyond the screened section, followed by a PVC elbow and a 4-inch vertical PVC riser pipe. Flush-threaded PVC casing and screen with no organic solvents or glues will be used. A filter pack of coarse silica sand will be placed entirely around the screened interval in the form of a gravel envelope. The trench will then be backfilled with the excavated residual soil and compacted to increase the soil density of this zone. The top 1 foot of the trench excavation will be completed with a soil/bentonite mixture overlain by a layer of bentonite. Powdered bentonite will also be applied to the surface soils in a rectangular surface cap extending at least 5 feet beyond the perimeter of the trench. A complete seal is critical to prevent injected air from short-circuiting to the surface during the bioventing test. Figure 3.3 illustrates the proposed central air injection well construction for this site.

A typical multi-depth VMP installation for this site is shown in Figure 3.4. Soil gas oxygen and carbon dioxide concentrations will be monitored at depth intervals of 1.5 to 2.5 feet and 4 to 5 feet at each location. Multi-depth monitoring will confirm that the entire soil profile is receiving oxygen and will be used to measure fuel biodegradation rates at both depths. The annular space between these two monitoring points will be sealed with bentonite to isolate the monitoring intervals. Data from the background VMP will also be used to determine the relative natural diffusion of atmospheric oxygen into the shallow soils. Additional details on VMP construction are found in Section 4 of the protocol document.

### **3.2 Handling of Soil Boring Cuttings and Excavated Soils**

Cuttings from all soil borings and any remaining waste soils will be collected in a U.S. Department of Transportation (DOT)-approved container. The containers will be labeled and then placed in a designated Charleston AFB hazardous material storage area. These waste soils will become the responsibility of Charleston AFB and will be analyzed, handled, and disposed of in accordance with the current procedures for ongoing remedial investigations. This project is expected to generate less than three 55-gallon drums of cuttings.

### **3.3 Soil Sampling**

Three soil samples will be collected from the pilot test area during the installation of the venting well and VMPs. Sampling procedures will follow those outlined in the protocol document, with minor modifications for collection of a sample from the trench. One sample will be collected from the most contaminated interval of the central venting well trench. One sample will be collected from the interval of highest apparent contamination in two of the borings for the monitoring points. Soil samples will be analyzed for TRPH, BTEX, soil moisture, pH, particle sizing, alkalinity, total iron, and nutrients.



Figure 3.4

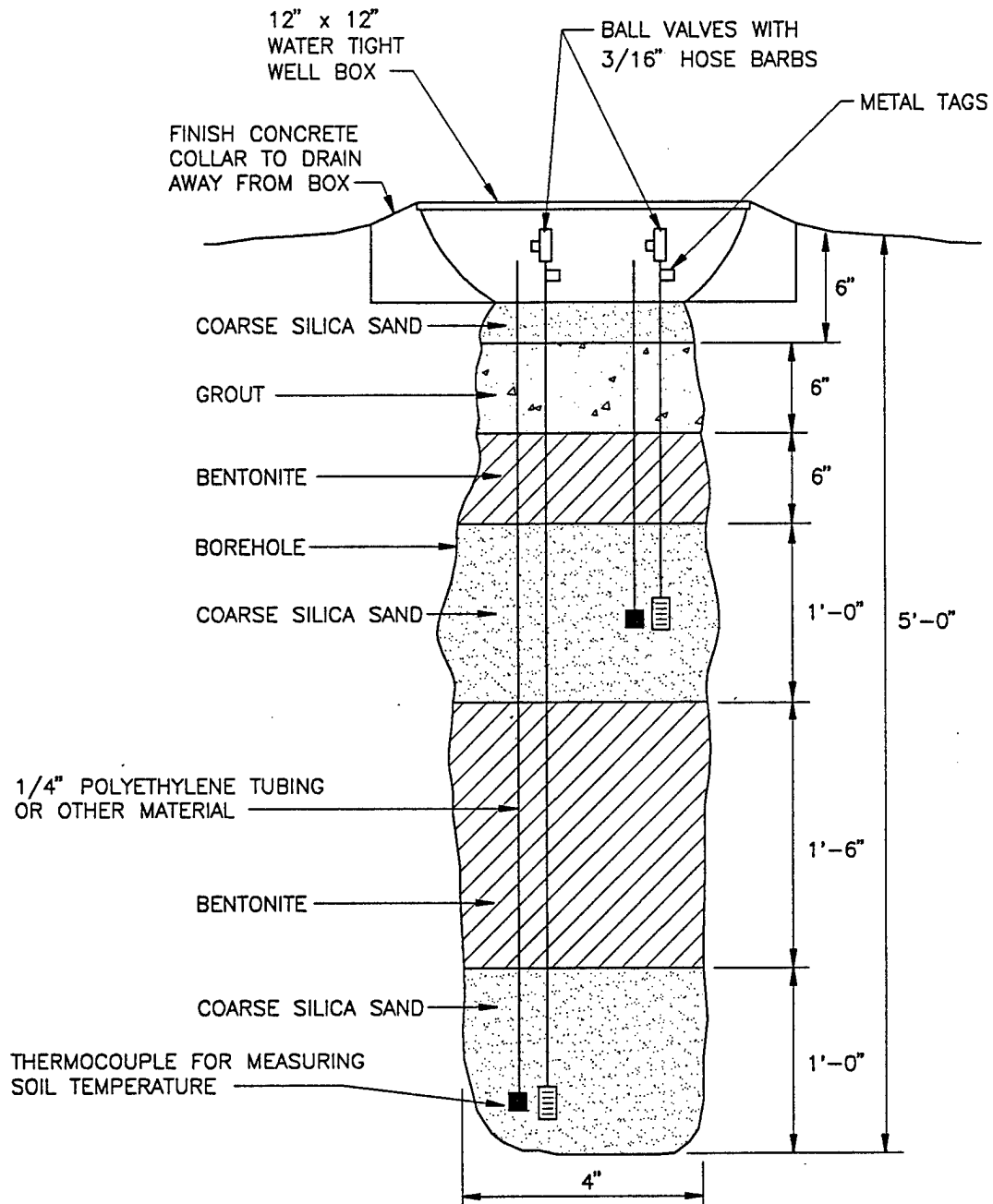

DE268-04.dwg / RD92267E.plt / 1=1 / Rev. 0 / TLP

Typical Monitoring Point  
Construction Detail

Site FT-03  
Charleston A.F.B.  
Charleston, South Carolina

Samples will be collected by hand augering to the desired sampling depth and then driving by hand either a small diameter Shelby tube or a split-spoon device equipped with a sampling sleeve. A photoionization detector or total hydrocarbon vapor analyzer (see protocol document Section 4.5.2.) will be used to ensure that breathing zone levels of VOCs do not exceed 1 ppmv while conducting soil borings and excavations and to screen split-spoon samples for intervals of high fuel contamination. Soil samples collected in the tubes will be immediately trimmed, and aluminum foil and a plastic cap will be placed over the ends. Soil samples will be labeled following the nomenclature specified in the protocol document (Section 5.5), wrapped in plastic, and placed in an ice chest will be for shipment. A chain-of-custody form will be filled out, and the ice chest shipped to the Engineering-Science laboratory in Berkeley, California for analysis. This laboratory has been audited by the U.S. Air Force and meets all quality assurance/quality control and certification requirements for the State of California.

### **3.4 Blower System**

A 1-horsepower regenerative blower capable of injecting 30 scfm at 2 pounds per square inch (psi) will be used to conduct the initial air permeability test at these sites. Air injection will be used to provide oxygen to soil bacteria and to minimize emissions of VOCs to the atmosphere. If initial testing indicates that less pressure is required to supply oxygen throughout the test volume, a smaller blower will be installed for extended testing. Figure 3.5 is a schematic of a typical air injection system that will be used for pilot testing at this site.

The maximum power requirement anticipated for this pilot test is a 230-volt, single-phase, 30-amp service. Figure 3.6 shows the electrical diagram for the blower system. Additional details on power supply requirements are described in Section 5.0, Base Support Requirements.

### **3.5 In Situ Respiration Test**

The objective of the *in situ* respiration test is to determine the rate at which soil bacteria degrade petroleum hydrocarbons. Respiration tests will be performed at every vapor monitoring point where bacterial biodegradation of hydrocarbons is indicated by low oxygen levels and elevated carbon dioxide concentrations in the soil gas. Air will be injected into each monitoring point depth interval containing low levels (<2%) of oxygen. A 10 to 15 hour air injection period will be used to oxygenate local contaminated soils. At the end of the air injection period, the air supply will be cut off, and oxygen and carbon dioxide levels will be monitored for the following 24 to 48 hours. The decline in oxygen and increase in carbon dioxide concentrations over time will be used to estimate rates of bacterial degradation of fuel residuals.

### **3.6 Air Permeability Test**



The objective of the air permeability test is to determine the extent of the subsurface that can be oxygenated using one air injection VW. Air will be injected into the 4-inch diameter vent well using the blower unit, and pressure response will be measured at each MP with differential pressure gauges to determine the region influenced by the unit. Oxygen will also be monitored in the MPs to ascertain that

Figure 3.5

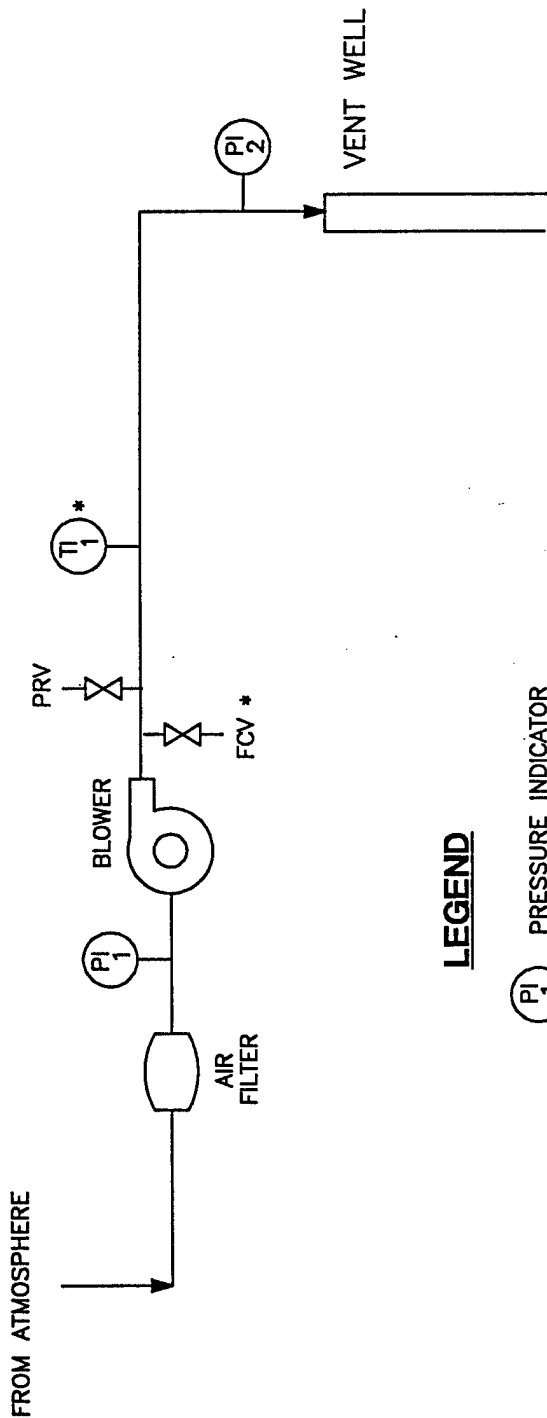
DE268-05.dwg / RD92267F.plt / 1=1 / Rev. 0 / TLP



**LEGEND**

-  PRESSURE INDICATOR
-  TEMPERATURE INDICATOR
- FCV FLOW CONTROL VALVE
- PRV PRESSURE RELIEF VALVE
- \* OPTIONAL

Blower System Instrumentation  
Diagram for Air Injection

Site FT-03  
Charleston A.F.B.  
Charleston, South Carolina

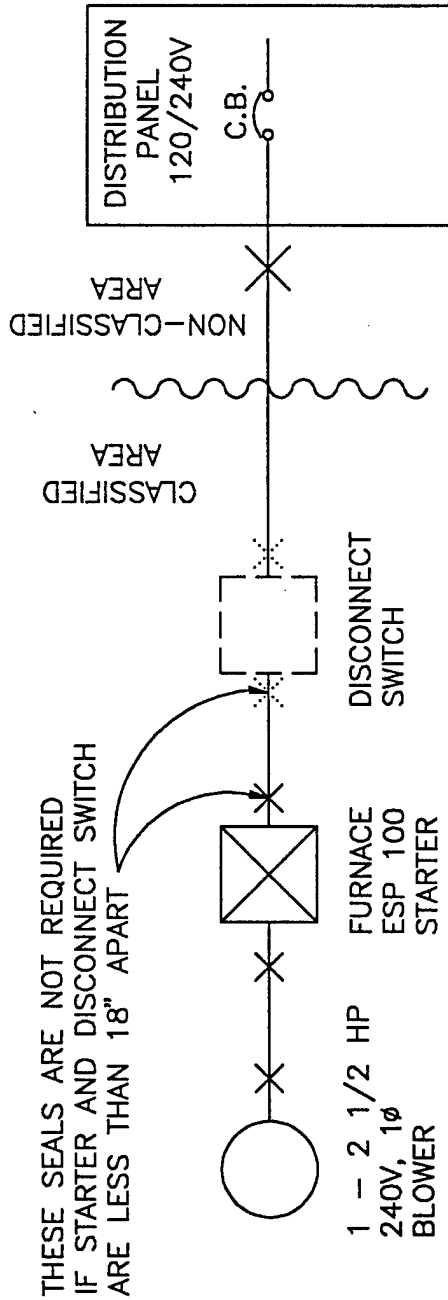

**TYPICAL ELECTRICAL ONE LINE DIAGRAM**

| BLOWER (H.P.) | CONDUIT (R.G.S.) | CONDUCTOR        | C.B.   |
|---------------|------------------|------------------|--------|
| 1/2 - 1       | 3/4"             | 2 - #12 & 1 #12G | 20A/2P |
| 1 1/2         | 3/4"             | 2 - #10 & 1 #10G | 25A/2P |
| 2             | 3/4"             | 2 - #10 & 1 #10G | 30A/2P |
| 1/2           | 3/4"             | 2 - #8 & 1 #10G  | 40A/2P |

**NOTES:**

1. IF THE MOTOR IS NOT WITHIN A LINE OF SIGHT FROM THE CIRCUIT BREAKER, PROVIDE A 30A/2P NON-FUSED DISCONNECT SWITCH ADJACENT TO THE STARTER (SHOWN AS DASHED ON THIS DRAWING) MOUNT 24" MINIMUM ABOVE FINISHED GRADE.
2. CONDUIT SEALS ARE NOT REQUIRED IF AREA IS NOT CLASSIFIED AS HAZARDOUS.
3. FOLLOW STARTER MANUFACTURER'S WIRING INSTRUCTIONS FOR ADAPTING A 3 PHASE STARTER TO A 2 POLE, SINGLE PHASE APPLICATION.
4. FOLLOW BLOWER MANUFACTURE'S WIRING INSTRUCTIONS TO MATCH BLOWER WIRING WITH VOLTAGE SUPPLIED.

Electrical Diagram  
for Blower System

Site FT-03  
Charleston A.F.B.  
Charleston, South Carolina

Figure 3.6

oxygen levels in the soil increase as the results of air injection. One air permeability test lasting 3 to 5 hours will be performed.

#### **4.0 EXCEPTIONS TO PROTOCOL PROCEDURES**

The testing procedures that will be used to measure the air permeability of the soil and *in situ* respiration rates are described in Sections 4 and 5 of the protocol document. No deviations from the established protocol are anticipated. The only foreseen exceptions to field testing protocol procedures are the possible use of existing wells for use as a VMP or as a background monitoring point.

Another exception to the procedures in the protocol document is the installation of a horizontal venting well. This deviation from standard venting well design is necessary to maximize the radius of oxygen influence and the ultimate success of the bioventing test. Current site conditions do not support the use of a vertical venting well, as this type of well construction would most likely result in injected air short circuiting to the surface. Installation of a horizontal venting well will require excavation with a backhoe equipped with a narrow (12-inch) bucket. A drilling contractor will not be needed for this site.

Soil borings for VMP installations will be advanced using a hand auger at this site. Since a drill rig will not be used, the typical borehole diameter for each monitoring point will be approximately 4 inches, as illustrated in Figure 3.4.

#### **5.0 BASE SUPPORT REQUIREMENTS**

##### **5.1 Test Preparation**

The following Base support is needed prior to the arrival of an excavation contractor and the Engineering-Science test team:

- Confirmation of regulatory approval for the pilot test.
- Assistance in obtaining a digging permit for the FT-03 site.
- A breaker box mounted to the existing power pole on the site which can supply 230-volt, single-phase, 30-amp service for the initial and extended pilot test. The breaker box should be located five feet above the ground and include one 230-volt outlet and two 110-volt outlets to support pilot testing equipment.
- Provide any paperwork required to obtain gate passes and security badges for approximately four Engineering-Science employees and two excavation contractors. Vehicle passes will be needed for three trucks.

During the initial 3-week pilot test the following Base support is needed:

- Twelve square feet of desk space and a telephone in a building located as near to the site as practicable.
- A decontamination pad where the excavation contractor can clean the backhoe bucket.

- Acceptance of responsibility for soil cuttings from venting well trench and monitoring point borings, including any drum sampling to determine hazardous waste status.
- The use of a fax machine for transmitting 15 to 20 pages of test results.

During the 1-year extended pilot test at Site FT-03, the following support will be needed:

- Check the blower system at the site once a week to ensure that it is operating and to record the air injection pressure. Engineering-Science will provide a brief training session and an operations and maintenance (O&M) checklist for this procedure.
- Notify Mr. Grant Watkins, Engineering-Science, Inc., Cary, North Carolina (919) 677-0080; or Mr. Doug Downey, Engineering-Science, Inc., Denver, Colorado (303) 831-8100; or Mr. Jim Williams of AFCEE, (800) 821-4528, ext. 246 if the blower or motor stop operating.
- Arrange site access for an Engineering-Science technician to conduct *in situ* respiration tests approximately 6 months and 1 year after the initial pilot test.

## 5.2 Permit Requirements

Base personnel are responsible for obtaining from the South Carolina Department of Health and Environmental Control (SCDHEC) all permits that are required to perform the test as described in this work plan. If required, Engineering-Science will assist this effort by providing test design criteria and reference documents for regulatory review. Unless directed by AFCEE or the Base point of contact, no direct contact will be made between Engineering-Science and the regulatory agencies.

Based on preliminary review of the test procedures, the SCDHEC will require an underground injection control (UIC) permit to perform any air injection into the subsurface. This permit will regulate the venting well as a Class V injection well. The permit will be required for both the short-term air permeability/respiration test and the extended bioventing test. Therefore, the proposed test schedule is dependent on timely permit approval by SCDHEC. The agency will also issue approval for the installation of the VMPs and the venting well.

## 6.0 PROJECT SCHEDULE

The following schedule is contingent upon timely approval of this pilot test work plan:

| Event  | Date               |
|--|--------------------|
| Draft Test Work Plan to AFCEE/Charleston AFB | September 24, 1992 |
| Approval To Proceed                          | October 1, 1992    |
| Begin Pilot Test                             | November 9, 1992   |

| <b>Event</b>                | <b>Date</b>       |
|-----------------------------|-------------------|
| Complete Initial Pilot Test | November 20, 1992 |
| Interim Results Report      | February 1, 1993  |
| Respiration Test            | March 1993        |
| Final Respiration Test      | November 1993     |

After a period of 1 year, a decision will be made by AFCEE and the Base to either remove the system or to expand the system for full-scale remediation at the site.

### **7.0 POINTS OF CONTACT**

Susan Davis/Lt Getz  
 437 SPTG/DEV  
 DSN 673-4976  
 Charleston AFB, South Carolina 29404-5045  
 (803) 566-4978

Major Ross Miller/Mr. Jim Williams  
 AFCEE/ESR  
 Brooks AFB, Texas 78235-5000  
 (800) 821-4528 ext.. 282, 246

Grant Watkins, P.G.  
 Engineering-Science, Inc.  
 401 Harrison Oaks Boulevard  
 Suite 210  
 Cary, North Carolina 27513  
 (919) 677-0080

Doug Downey  
 Engineering-Science, Inc.  
 1700 Broadway  
 Suite 900  
 Denver, Colorado 80290  
 (303) 831-8100

### **8.0 REFERENCES**

Hinchee, R.E., S.K. Ong., R.N. Miller, D.C. Downey, and R. Frandt. 1992. *Test Plan and Technical Protocol for a Field Treatability Test for Bioventing*. Prepared for Air Force Center for Environmental Excellence. May. Denver, Colorado.

Versar, Inc. 1992. *Installation Restoration Program Phase II- Remedial Investigation/Feasibility Report Study, Stage 2, Charleston Air Force Base, Charleston, South Carolina. (Draft Report)*.

**PART II  
DRAFT  
INTERIM PILOT TEST RESULTS REPORT  
FIRE PROTECTION TRAINING AREA SITE FT-03  
CHARLESTON AFB, SOUTH CAROLINA**

Prepared for:

**AIR FORCE CENTER FOR ENVIRONMENTAL EXCELLENCE  
BROOKS AFB, TEXAS**

and

**HEADQUARTERS 437 AIRLIFT WING (AMC)  
CHARLESTON AFB, SOUTH CAROLINA**

January 1993

Prepared by:

**Engineering-Science, Inc.  
1700 Broadway, Suite 900  
Denver, Colorado**

**PART II**  
**CONTENTS**

|     |   | <u>Page</u> |
|-----|---|-------------|
| 1.0 | Pilot Test Design and Construction .....            | II-1        |
| 1.1 | Air Injection Vent Well Construction .....          | II-4        |
| 1.2 | Permanent Monitoring Points.....                    | II-4        |
| 1.3 | Temporary Monitoring Points .....                   | II-6        |
| 1.4 | Blower Unit Installation and Operation .....        | II-8        |
| 2.0 | Pilot Test Soil and Soil Gas Sampling Results ..... | II-8        |
| 2.1 | Sampling Results.....                               | II-8        |
| 2.2 | Exceptions to Test Protocol .....                   | II-10       |
| 2.3 | Field QA/QC Results .....                           | II-11       |
| 3.0 | Pilot Test Results .....                            | II-12       |
| 3.1 | Initial Soil Gas Chemistry .....                    | II-12       |
| 3.2 | Air Permeability.....                               | II-12       |
| 3.3 | Oxygen Influence .....                              | II-14       |
| 3.4 | <i>In Situ</i> Respiration Rates.....               | II-14       |
| 3.5 | Potential Air Emissions .....                       | II-21       |
| 4.0 | Recommendations .....                               | II-21       |
| 5.0 | References.....                                     | II-22       |
|     | Appendix A O&M Checklist                            |             |
|     | Appendix B Chain-of-Custody Form                    |             |

**TABLES**

| <u>No.</u> | <u>Title</u>   | <u>Page</u> |
|------------|--|-------------|
| 2.1        | Soil Laboratory Analytical Results.....  | II-11       |
| 3.1        | Initial Soil Gas Chemistry.....  | II-13       |
| 3.2        | Pressure Response Air Permeability Test.....   | II-15       |
| 3.3        | Influence of Air Injection at Venting Well on<br>Monitoring Point Oxygen Levels..... | II-17       |
| 3.4        | Apparent Oxygen Utilization Rates.....   | II-20       |

## FIGURES

| <u>No.</u> | <u>Title</u>  | <u>Page</u> |
|------------|---|-------------|
| 1.1        | Venting Well, Vapor Monitoring Points, and Blower Locations ..... | II-2        |
| 1.2        | Hydrogeologic Cross Section.....                                  | II-3        |
| 1.3        | As-Built Injection Venting Well and Trench Construction .....     | II-5        |
| 1.4        | As-Built Permanent Monitoring Point Construction Detail .....     | II-7        |
| 1.5        | As-Built Blower System for Air Injection.....                     | II-9        |
| 3.1        | Respiration Test: Monitoring Point MPD-3.9.....                   | II-18       |
| 3.2        | Respiration Test: Monitoring Point BG-2.5 .....                   | II-19       |

**PART II**  
**DRAFT**  
**INTERIM PILOT TEST RESULTS REPORT**  
**FOR FIRE PROTECTION TRAINING AREA SITE FT-03**  
**CHARLESTON AFB, SOUTH CAROLINA**

An initial bioventing pilot test was performed at Fire Protection Training Area Site FT-03 at Charleston Air Force Base (AFB), South Carolina from November 9 through 13, 1992. The purpose of this Part II report is to describe the results of the initial pilot test at Site FT-03 and to make specific recommendations for extended testing to determine the long-term impact of bioventing to remediate site contaminants. Descriptions of the history, geology, and site contaminants of Site FT-03 are found in Part I of this report, Bioventing Pilot Test Work Plan.

**1.0 PILOT TEST DESIGN AND CONSTRUCTION**

A horizontal trench and air injection venting well (VW) were installed on October 28, 1992 by the Cary, North Carolina office of Engineering-Science, Inc. (ES) and a subcontractor, Groundwater Protection, Inc. (Remediation Division) of Charlotte, North Carolina. Four permanent pressure/vapor monitoring points (MPs) were installed on October 29, 1992. The VW construction, MP installations, and soil sampling were directed by Mr. Grant Watkins, P.G., the Engineering-Science, Inc. (ES) site manager. The following sections describe in more detail the final design, installation, and testing of the bioventing system at this site.

One VW, four permanent MPs, and a blower unit in a weather-proof enclosure were installed at Site FT-03 for the extended bioventing test. Prior to conducting the air permeability and respiration tests, eight shallow soil gas probes were installed adjacent to the permanent MPs to serve as temporary MPs. The temporary soil gas probes were installed to monitor soil gas conditions in very shallow soils (<2.5 feet deep), as an unseasonably high water table at the site prevented installation of permanent, multi-depth MPs.

The locations of the VW and MPs were changed from the original work plan after a site survey indicated that these proposed locations did not contain soils that were significantly contaminated or oxygen deficient. The unusually high water table at the site also prevented using existing groundwater monitoring wells for soil gas and pressure monitoring during the tests. A soil gas probe was subsequently installed to serve as a background MP. Figure 1.1 depicts the test area with the locations of the MPs, horizontal VW, and blower. Figure 1.2 shows a hydrogeologic cross section in a north-south direction, perpendicular to the axis of the horizontal VW.

Figure 1.1

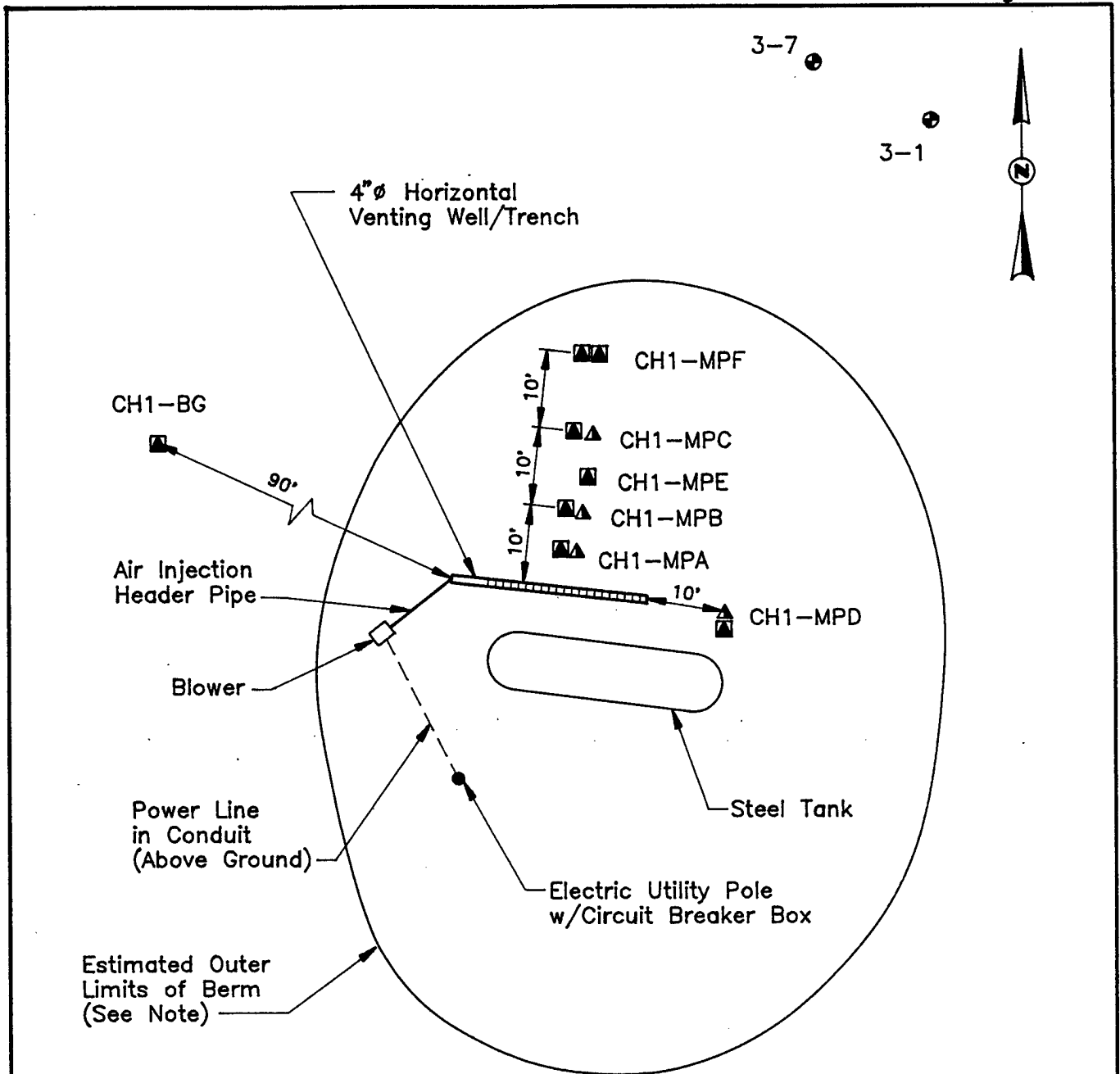

**LEGEND**

- CH1-MPA  $\blacktriangle$  Permanent soil vapor/pressure monitoring point.
- CH1-MPA  $\blacksquare$  Temporary soil vapor/pressure monitoring point (soil vapor probe).
- CH1-BG  $\blacksquare$  Temporary background monitoring point.
- 3-7  $\bullet$  Groundwater monitoring well.

NOTE: Soil berm has approximate elliptical dimensions.

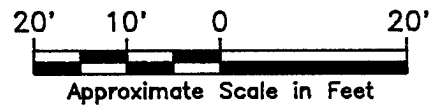

Venting Well, Vapor Monitoring Points, and Blower Locations

Site FT-03  
Fire Training Area  
Charleston AFB, South Carolina

DEZ68-09.dwg / 1=20 / 1-29-93 / TLP

Figure 1.2

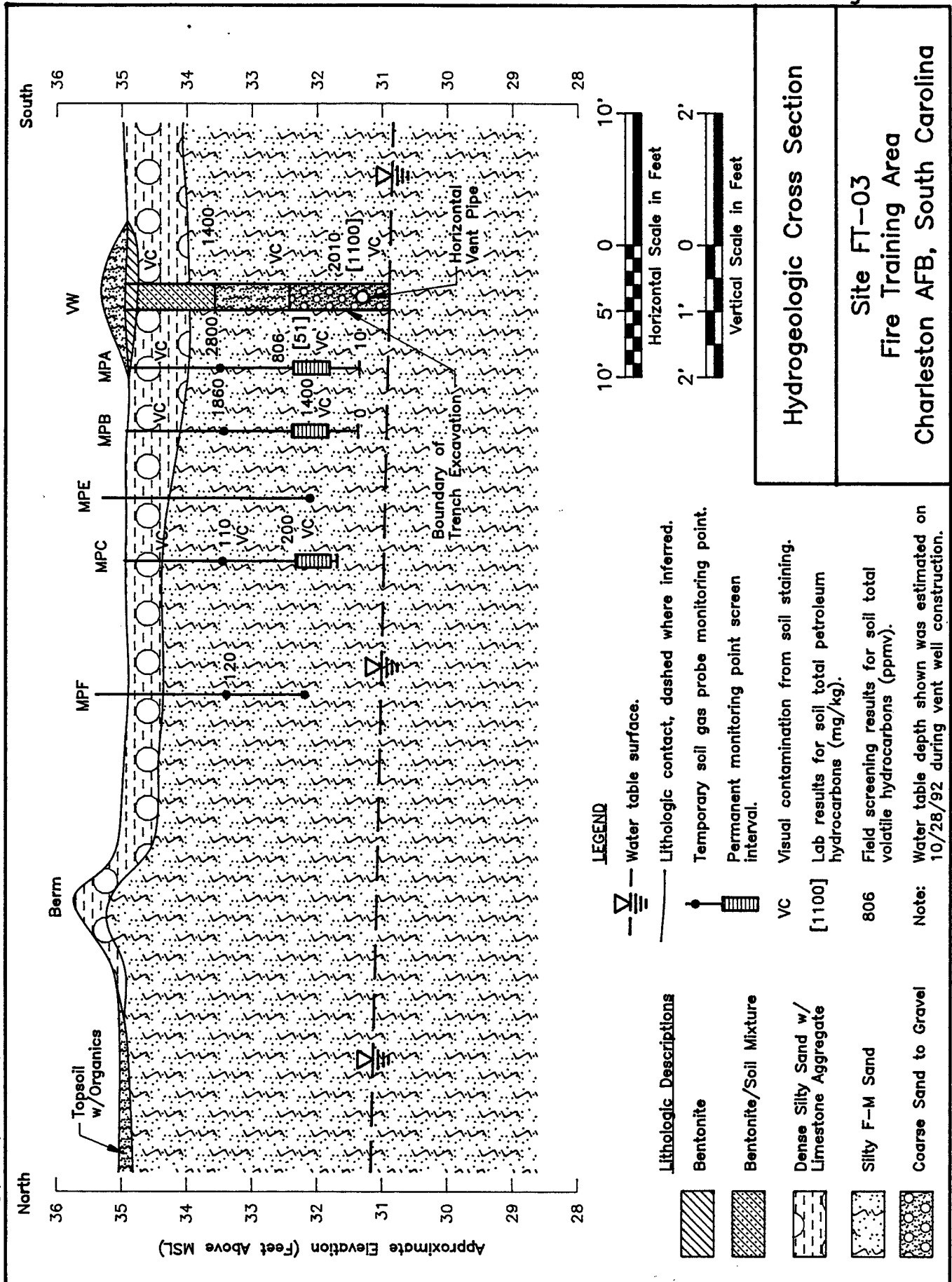

Hydrogeologic Cross Section

Site FT-03  
 Fire Training Area  
 Charleston AFB, South Carolina

## **1.1 Air Injection Venting Well Construction**

The air injection VW was installed within the bermed area of the fire training pit, as shown in Figure 1.1. The VW was constructed in a shallow trench excavated in visibly contaminated, oxygen-depleted soils. Soils in the immediate vicinity of the trench were darkly stained and emitted hydrocarbon odors.

A horizontal air injection VW was installed at this site because the relatively shallow water table prevented the proper installation of a vertical VW according to typical AFCEE work plan protocols (Hinchee et al., 1992). Figure 1.3 shows the as-built construction details of the trench and VW. On the date of the VW/trench installation, water levels at Site FT-03 were approximately 4 feet below land surface (bls). According to previous IRP reports for this site, these water level elevations are 1 to 2 feet higher than the historical normal water levels for that time of year. Consequently, the installation depth of the trench/VW was decreased approximately 1 foot from those depths proposed in the Bioventing Pilot Test Work Plan (see Part I).

A backhoe equipped with a front-end loader and an 18-inch-diameter bucket was used for the trench excavation. A 5-foot perimeter around the excavation was prepared by removing the vegetation, topsoil, and limestone aggregate layers to a depth of approximately 3 inches. The excavation was then completed to the water table at a depth of 4 feet BLS for a distance of 27 feet. The trench excavation was widened slightly on the east end to avoid an 8-inch-diameter steel pipe of unknown origin that was encountered in the subsurface.

Upon completing the trench excavation, the VW was constructed using 4-inch-diameter, Schedule 40 polyvinyl chloride (PVC) screen and casing. A 20-foot section of 0.03-inch slotted screen and a 5-foot section of threaded casing were installed in the excavation approximately 6 inches above the water table. The screen section was surrounded by a coarse silica sand/gravel pack. A thermocouple was also attached to the middle of the screen section. A flanged PVC elbow equipped with a 150-pounds-per-square-inch (psi) compression gasket was used to connect the horizontal section of the vent piping to a vertical 4-inch-diameter PVC riser to the ground surface. The gravel pack was overlain by residual soil compacted with a tamp to minimize vertical air losses through the excavation. The upper 1.3 feet of the excavation was backfilled with a mixture of residual soils and bentonite. A bentonite cap 1 to 2 inches thick was placed over the trench and extended outward 5 feet in all directions to minimize short-circuiting of injected air and surface water infiltration. As shown in Figures 1.2 and 1.3, a surface cap of residual soil was also constructed in a crown over the bentonite layer to promote surface drainage away from the trench.

## **1.2 Permanent Monitoring Points**

Four permanent MPs were installed on October 29, 1992. Monitoring points MPA, MPB, MPC were installed perpendicular to the VW axis at respective distances of 5, 10, and 20 feet, while the fourth point (MPD) was installed parallel to the axis 10 feet from the east end of the VW (see Figure 1.1). The permanent MP boreholes were advanced using a decontaminated hand auger. Only one MP screen

Figure 1.3

**Notes:**

1. Drawing is not to scale.
2. All fittings are threaded or compression type. No PVC cement was used.
3. Water table surface was 4.0 feet below original ground surface on 10/28/92.
4. Trench and venting well installed on 10/28/92.

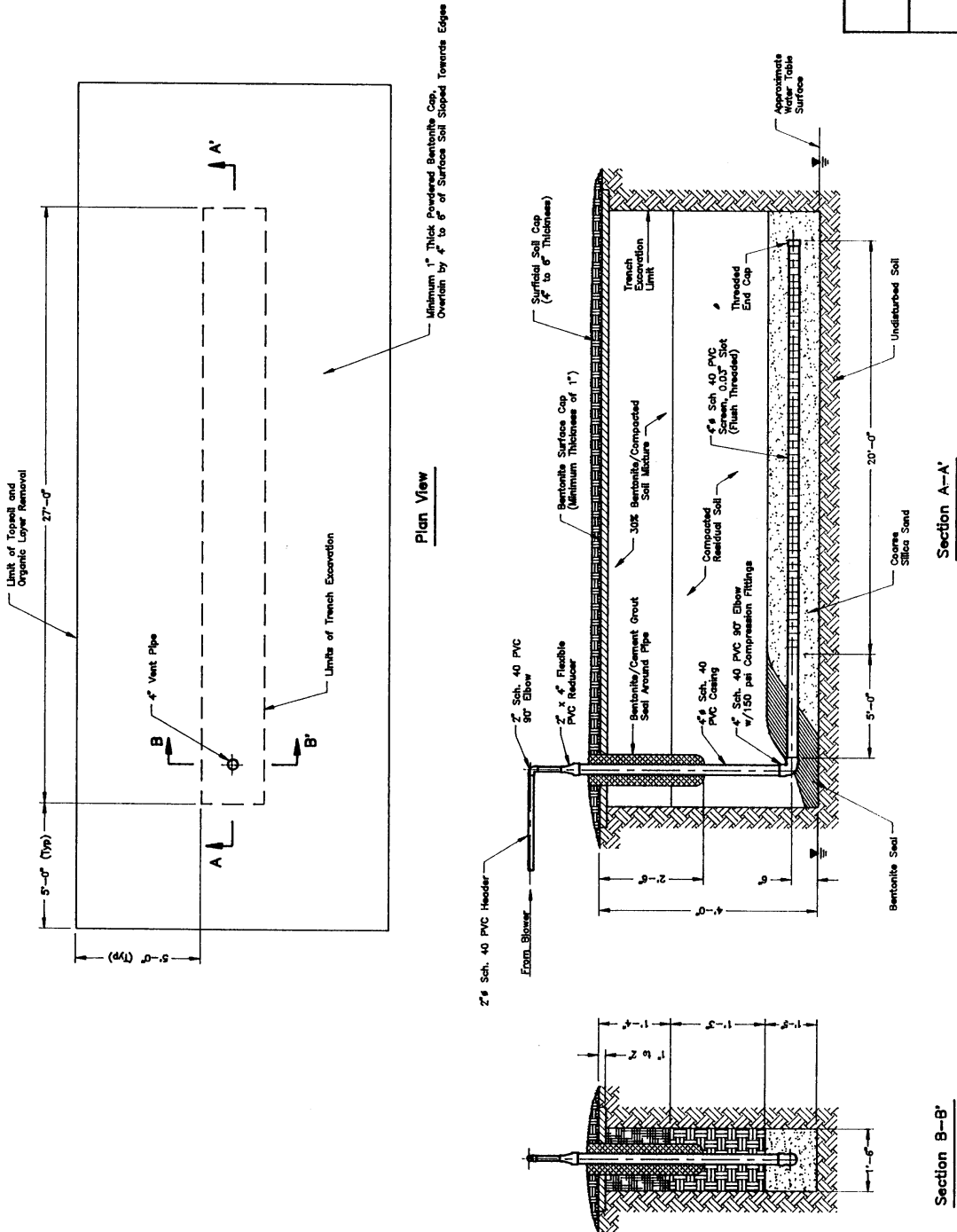

As-Built Injection Venting Well  
and Trench Construction

Site FT-03  
Fire Training Area  
Charleston AFB, South Carolina

was installed per borehole. Multi-depth MP screens could not be installed at Site FT-03 as planned, as the shallow water table conditions would not accommodate construction of multiple bentonite and grout seals with adequate integrity.

The four permanent MPs were constructed using 0.5-inch-diameter PVC screens and casings installed in 4-inch diameter boreholes. Each MP was constructed using a 6-inch section of 0.02-inch slotted, Schedule 80 PVC screen and Schedule 40 PVC casing. The screened interval was surrounded by a gravel pack of #2 coarse silica sand. Thermocouples were also installed at the screened interval of MPD-3.9 and MPA-3.5. Bentonite and grout were used to seal the annulus around each riser above the gravel pack. The top of each PVC riser was completed near the ground surface with a brass gas ball valve and a 3/16-inch hose barb. Each MP was completed at the surface with a flush-mounted metal well vault set in a concrete base. The lid of the metal well vault was set several inches above the ground surface, and the concrete base was sloped toward the edges to promote drainage of surface water away from the MP. Figure 1.4 shows a construction schematic of a typical permanent MP.

### 1.3 Temporary Monitoring Points

Eight temporary MPs were installed in the Site FT-03 test area to monitor shallow soil gas conditions during the tests. Five of the points, including the background monitoring point CH1-BG, were installed on November 9, 1992, prior to conducting the air permeability test. Two additional temporary MPs (MPE and MPF) were installed after evaluating the air permeability test responses and before conducting the *in situ* respiration test. One of the temporary MPs (MPE) was used to replace MPA-3.5, which began collecting water in the screens after heavy rains raised the water table even further at the site.

The temporary MPs were installed using an AMS® Soil Gas Vapor Kit and dedicated soil vapor probes. The soil vapor probes were advanced adjacent to existing permanent MPs to provide the shallow (i.e., 1 to 2 feet deep) monitoring intervals that could not be constructed in the boreholes using PVC screens and riser. With the exception of the background MP, most of the soil vapor probes did not exceed a depth of 2.5 feet. Each MP was advanced to the desired depth using a carbon steel rod with internal polypropylene tubing connected to the soil vapor probe. Soil around the steel rod was tamped to prevent short-circuiting of air between the probe tip and the ground surface. Care was also taken not to purge large volumes of air through the probes so that ambient atmospheric air was not retrieved during soil vapor monitoring procedures.

Figure 1.1 shows the locations of the temporary soil gas monitoring probes. Figure 1.2 depicts a vertical profile of several soil vapor probe monitoring intervals. The temporary probes currently remain in place at Site FT-03 to provide shallow soil monitoring capabilities during extended bioventing testing. Unseasonably heavy rainfall in the Charleston area has continued to elevate the water table at the site, causing some of the permanent MP well screens to become submerged. The temporary soil gas MP probes will be removed when the shallow monitoring capabilities are no longer needed.

Figure 1.4

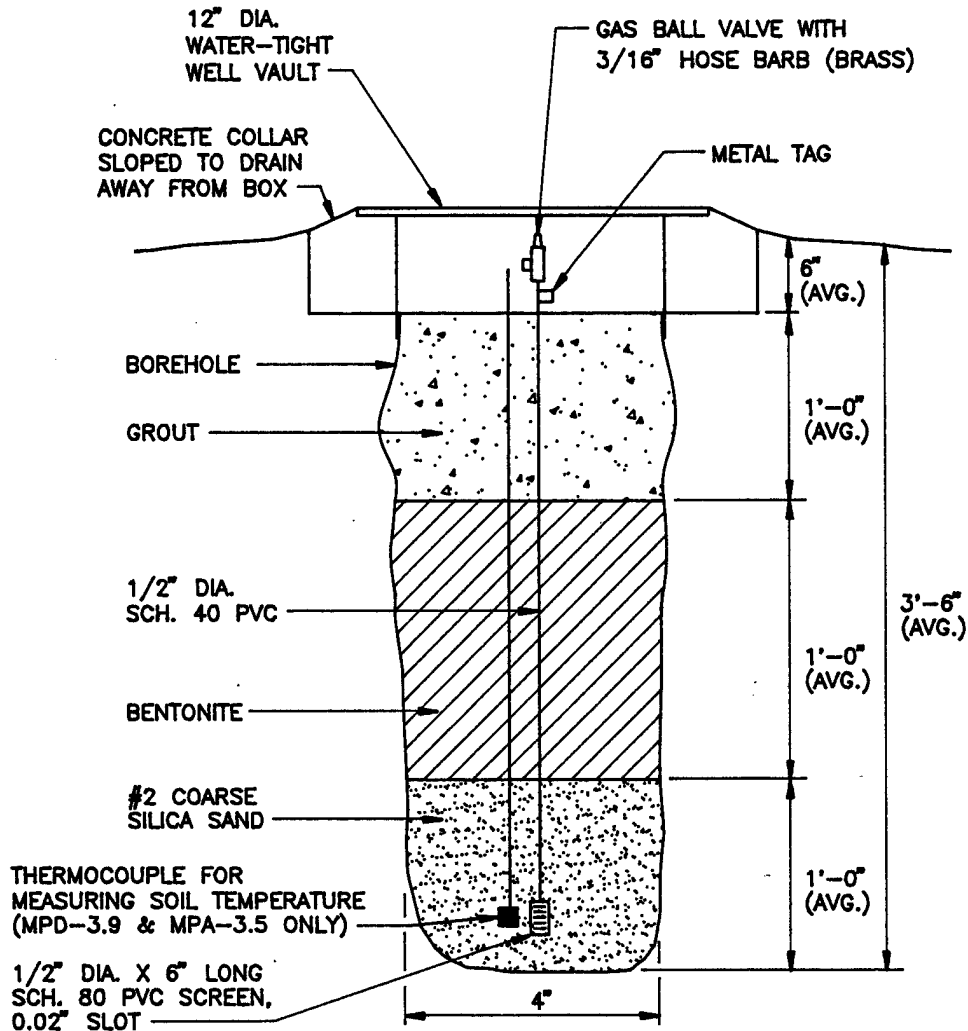

DRAWING IS NOT TO SCALE

**MONITORING POINT CONSTRUCTION SPECIFICATIONS**

| Monitoring Point No. | Borehole Depth (FT) | Screen Interval (Feet BLS) |
|----------------------|---------------------|----------------------------|
| MPA-3.5              | 3.5                 | 2.5-3.0                    |
| MPB-3.5              | 3.5                 | 2.5-3.0                    |
| MPC-3.25             | 3.25                | 2.6-3.1                    |
| MPD-3.9              | 3.9                 | 2.8-3.3                    |

**As-Built Permanent Monitoring Point Construction Detail**

Site FT-03  
 Fire Training Area  
 Charleston AFB, South Carolina

DE268-04.dwg / 1=1 / 1-19-93 / TLP

#### 1.4 Blower Unit Installation and Operation

A 1-horsepower Gast® R4110-2 regenerative blower unit was installed at Site FT-03 for the extended pilot test. The air permeability test was conducted using a portable 1-horsepower Rotron® DR404 regenerative blower. The Gast® blower was installed in a weatherproof enclosure and is energized by 230-volt, single-phase, 30-amp line power from a newly installed aboveground electrical utility pole and circuit breaker provided by the Base. Air is supplied by the blower through a 2-inch-diameter aboveground PVC header pipe that is attached to the VW using a flexible PVC 4-inch-to-2-inch reducer. Figure 1.5 shows the configuration, instrumentation, and specifications for the blower and air injection system.

The blower began operation for the extended bioventing test on November 23, 1992. Before starting the extended test, water was noted in the VW as a result of four consecutive days of heavy rainfall the prior week. A water level was measured in the VW, and it was determined that the VW piping was submerged under approximately 11 inches of water. The elevated water table at the site was confirmed by placing a hand-augered boring on the north edge of the fire training pit berm, where the water table stabilized in the open borehole at a depth of 2.2 feet bls.

Rather than wait for the water levels to subside at the site, ES began the extended bioventing test by first starting the blower with the manual pressure relief valve fully open and then slowly closing it to begin blowing pressurized air into the VW at an initial injection pressure of 42 inches of water [approximately 45 standard cubic feet per minute (scfm)]. This initial elevated injection back pressure was created by the saturated conditions of the formation surrounding the VW screen, as the manual pressure relief valve was almost completely closed after the blower was started. The initial high injection pressure was intended to remove water from the VW and surrounding formation so that effective air flow could be established in the unsaturated zone. A system resembling *in situ* air sparging was effectively produced during this procedure until the formation water could be displaced. ES has since revisited the site and reduced the air flow and injection pressures into the VW by opening the manual bleed valve even further. The current operating air injection rate is approximately 10 to 15 scfm. Soil pore pressures are being maintained at distances exceeding 30 feet from the VW at this flow rate.

Prior to departing from the site, ES personnel provided operations and maintenance (O&M) instructions to Base personnel. A copy of the O&M checklist is provided in Appendix A.

## 2.0 PILOT TEST SOIL AND SOIL GAS SAMPLING RESULTS

### 2.1 Sampling Results

Soil gas samples were not collected for quantitative analysis during the startup period for the bioventing test. The soil gas samples will be collected before the 6-month respiration test if the water table has subsided at the site.

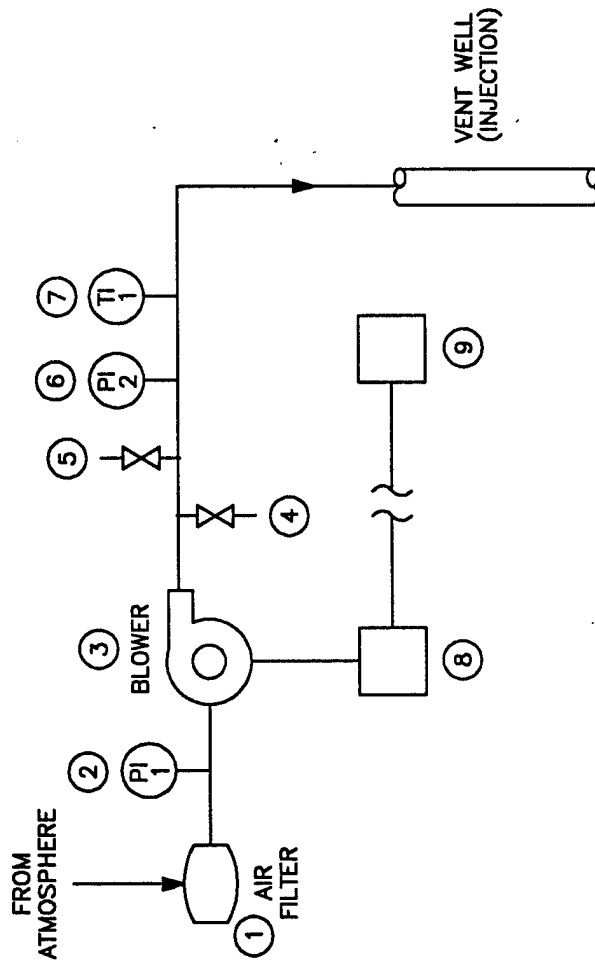

**LEGEND**

- ① INLET AIR FILTER - SOLBERG F-18P-150
- ② VACUUM GAUGE (in H<sub>2</sub>O)
- ③ BLOWER - GAST R4110-2
- ④ MANUAL PRESSURE RELIEF (BLEED) VALVE - 1 1/2" GATE
- ⑤ AUTOMATIC PRESSURE RELIEF VALVE
- ⑥ PRESSURE GAUGE (in H<sub>2</sub>O)
- ⑦ TEMPERATURE GAUGE (F)
- ⑧ STARTER - FURNAS 14CSD33DA NEMA 3
- ⑨ BREAKER BOX - 230V/SINGLE PHASE/30 AMP

DRAWING IS NOT TO SCALE

As-Built Blower System  
for Air Injection

Site FT-03  
Fire Training Area  
Charleston AFB, South Carolina

Figure 1.5

Soils at Site FT-03 consist of loose to dense, silty, fine to medium sand from ground surface to below the water table surface, which typically averages 5 to 6 feet BLS. The silty sand unit ranges in color from pale gray to pale brown and yellowish-brown, with the exception of those areas that are stained black from fuel contamination. Fire training pit FT-03 was constructed in a heavily vegetated area, and some remnant organic material (e.g., tree roots and stumps) was encountered in the upper 4 feet of the soil profile. The berm and base of the fire training pit are overlain with a limestone aggregate, which is compacted within a matrix of residual silty sand to form a relatively dense lining with an average thickness of 1 foot in the middle of the pit. Shallow silica-based soils in the center of the pit have been noticeably glazed, or vitrified, from the intense heat of the fires.

Soil hydrocarbon contamination at this site appears to be confined mainly within the bermed area. Contaminated soils were identified based on visual appearance, odor, and volatile organic compound (VOC) field screening results. Heavily contaminated soils were encountered in the VW trench and MPD borehole. Soils in these areas had strong hydrocarbon odors and were visibly stained from oily fuel contamination. The greatest concentrations of contamination appeared to occur in the upper 3 feet of the soil profile. Soil gas VOC readings exceeded 20,000 part per million, volume per volume (ppmv) of total hydrocarbons in MPD-3.9. Groundwater encountered during the trench excavation did not contain immiscible, floating fuel product.

Soil samples for laboratory analysis were collected from the hand-augered MP cuttings and were transferred to appropriate glass containers. Soil samples collected from the MP borings were placed in air-tight plastic bags and screened for VOCs in the field using a photoionization detector (PID). The PID headspace screening results were used to determine the relative contamination of each sample and as a guide for selecting samples for laboratory analyses. Soil samples for laboratory analysis were collected from MPA at a depth of 2.5 feet, from MPD at a depth of 3 feet, and from the center of the VW trench at a depth of 3.5 feet.

Soil samples were shipped by Federal Express® to the ES Berkeley laboratory for chemical and physical analyses. Each of the soil samples were analyzed for the following parameters: total recoverable petroleum hydrocarbons (TRPH); benzene, toluene, ethylbenzene and xylenes (BTEX); iron; alkalinity; total Kjeldahl nitrogen (TKN); pH; phosphates; percent moisture; and grain size distribution. The results of these analyses are presented in Table 2.1 and the chain-of-custody form is presented in Appendix B.

## **2.2 Exceptions to Test Protocol Document Procedures**

Test procedures described in the protocol document (Hinchee et al., 1992) were used to complete treatability pilot tests at the site. Several exceptions to both the standard protocol and the Bioventing Pilot Test Work Plan (Part I) were necessary based on conditions encountered at Site FT-03. A horizontal VW was installed due to the shallow water table at the site. The VW location was moved to within the bermed area of the fire pit after a field survey of subsurface conditions was performed. Additionally, the final VW installation depth was approximately one

**TABLE 2.1**  
**SOIL SAMPLE LABORATORY ANALYTICAL RESULTS**  
**SITE FT-03**  
**CHARLESTON AFB, SOUTH CAROLINA**

| Analyte (Units) <sup>a/</sup>               | Sample Location-Depth<br>(feet below land surface) |                |              |
|---|--|----------------|--------------|
|   | <u>VW-3.5</u>                                      | <u>MPA-2.5</u> | <u>MPD-3</u> |
| <u>Soil Hydrocarbons</u>                    |  |                |              |
| TRPH (mg/kg)                                | 1,100  | 51             | 2,200        |
| Benzene (mg/kg)                             | ND <sup>b/</sup>                                   | ND             | ND           |
| Toluene (mg/kg)                             | 2.6  | 2.7            | ND           |
| Ethylbenzene (mg/kg)                        | 1.6  | ND             | ND           |
| Xylenes (mg/kg)                             | 4.6  | 1.3            | ND           |
| <u>Soil Inorganics</u>                      | <u>VW-3.5</u>                                      | <u>MPA-2.5</u> | <u>MPD-3</u> |
| Iron (mg/kg)                                | 3,760  | 3,010          | 2,060        |
| Alkalinity<br>(mg/kg as CaCO <sub>3</sub> ) | 650  | ND             | 170          |
| pH (units)                                  | 7.4  | 6.6            | 7.4          |
| TKN (mg/kg)                                 | 180  | 520            | 360          |
| Phosphates (mg/kg)                          | 96   | 850            | 100          |
| <u>Soil Physical Parameters</u>             | <u>VW-3.5</u>                                      | <u>MPA-2.5</u> | <u>MPD-3</u> |
| Moisture (% wt.)                            | 16.5   | 15.4           | 11.3         |
| Gravel (%)                                  | 0  | 6              | 0            |
| Sand (%)                                    | 74   | 65.5           | 75           |
| Silt (%)                                    | 19   | 21             | 20           |
| Clay (%)                                    | 7  | 7.5            | 5            |

a/ TRPH = total recoverable petroleum hydrocarbons; mg/kg = milligrams per kilogram, ppmv = parts per million, volume per volume; CaCO<sub>3</sub> = calcium carbonate; TKN = total Kjeldahl nitrogen.

b/ ND = not detected.

foot less than proposed in the Bioventing Pilot Test Work Plan due to the exceptionally high water table encountered during trench excavation. High water levels at the site also prevented using existing monitoring wells during the pilot tests, requiring the installation of a separate background MP. Multi-depth MP screens were not installed in individual boreholes, and temporary soil gas probes were substituted to provide monitoring of the very shallow soils.

Soil sampling procedures were also modified from the protocol because the MP boreholes were installed with a hand auger. Samples obtained for laboratory analysis were collected directly from hand-auger cuttings and were not obtained using brass sampling sleeves (liners) as stated in the protocol. Field headspace screening of these soil samples was also performed using a PID instead of a total hydrocarbon analyzer.

Soil gas samples will be collected at this site in late January or early February 1993 if groundwater levels drop, and permanent soil gas monitoring points are not submerged. Soil gas samples will be collected in SUMMA<sup>®</sup> canisters in accordance with the *Bioventing Field Sampling Plan* (ES, 1992) from the VW and from the MPs closest to and furthest from the VW. Additionally, these soil gas samples will be used to predict potential air emissions, to determine the reduction in BTEX and total volatile hydrocarbons (TVH) during the 1-year test, and to detect any migration of these vapors from the source area.

Soil gas sample canisters will be placed in a smaller cooler and packed with foam pellets to prevent excessive movement during shipment. Samples will not be sent on ice to prevent condensation of hydrocarbons. A chain of custody form will be filled out and the cooler shipped to the Air Toxics laboratory in Rancho Cordova, California for analysis.

### **2.3 Field QA/QC Results**

No field QA/QC samples were required to be collected at this site.

## **3.0 PILOT TEST RESULTS**

### **3.1 Initial Soil Gas Chemistry**

Prior to initiating any air injection, all MPs were purged until oxygen levels had stabilized, and initial oxygen, carbon dioxide, and then TVH concentrations were sampled using portable gas analyzers, as described in the technical protocol document (Hinchee et al., 1992). In contaminated soils, microorganisms had depleted soil gas oxygen supplies to less than 1 percent. In contrast, the background MP, outside the area of contamination, had 20.8 percent oxygen at a depth of 2.5 feet. Table 3.1 summarizes the initial soil gas chemistry at Site FT-03. TRPH data are also provided to demonstrate the relationship between lower oxygen levels and the more contaminated soils.

### **3.2 Air Permeability**

An air permeability test was conducted according to protocol document procedures. Air was injected into the VW for 3 hours at a rate of approximately 27.5 scfm and an average pressure of approximately 50 inches of water. The

**TABLE 3.1**  
**INITIAL SOIL GAS CHEMISTRY**  
**SITE FT-03**  
**CHARLESTON AFB, SOUTH CAROLINA**

| Sample Location | Depth (ft) | O <sub>2</sub> (%) | CO <sub>2</sub> (%) | TVH (ppmv) <sup>a/</sup> | TPH (mg/kg) <sup>b/</sup> | Temp (°F) |
|-----------------|------------|--------------------|---------------------|--------------------------|---------------------------|-----------|
| MPA             | 1.4        | 9.9                | 4.0                 | 2,800                    | NS <sup>c/</sup>          | NS        |
| MPB             | 1.5        | 6                  | 6.2                 | 1,860                    | NS                        | NS        |
| MPC             | 1.5        | 12.2               | 4.3                 | 110                      | NS                        | NS        |
| MPD             | 1.8        | 0.8                | 7.3                 | 5,600                    | NS                        | NS        |
| MPA             | 3.5        | 0                  | 8.2                 | 5,000                    | 51 <sup>d/</sup>          | 63.8      |
| MPB             | 3.5        | 0                  | 7.8                 | 1,400                    | NS                        | NS        |
| MPC             | 3.25       | 0                  | 6.3                 | 200                      | NS                        | NS        |
| MPD             | 3.9        | 0                  | 8.4                 | >20,000                  | 2,200 <sup>e/</sup>       | 65.0      |
| Background      | 2.5        | 18.7               | 0.2                 | 94                       | NS                        | NS        |

- a/ PID field screening results.
- b/ Laboratory results.
- c/ NS = not sampled.
- d/ Sampled at a depth of 2.5 feet.
- e/ Sampled at a depth of 3 feet.

pressure responses at each MP are listed in Table 3.2. Due to the gradual response and relatively lengthy time to achieve steady-state conditions, the dynamic method of determining soil permeability was selected. Using the HyperVentilate® model, an air permeability value ranging from 4 to 8 darcys was calculated for this site. The radius of pressure influence is estimated to be between 30 and 40 feet.

### 3.3 Oxygen Influence

The depth and radius of oxygen increase in the subsurface resulting from air injection into the central VW during pilot testing is the primary design parameter for full-scale bioventing systems. Optimization of full-scale and multiple VW systems requires pilot testing to determine the volume of soil that can be oxygenated at a given flow rate and VW screen configuration.

Table 3.3 describes the change in soil gas oxygen levels that occurred during the air permeability test when air was injected at 27.5 scfm for a period of 3 hours. Oxygen level increases were measured at all MPs except in MPD at a depth of 3.9 feet, where the oxygen level remained constant, and in MPC at a depth of 1.5 feet, where the level decreased. No final oxygen reading was taken from MPC at the 3.25-foot depth due to high water in this MP. The decreased oxygen level measured at MPC at the 1.5-foot depth was probably the result of oxygen-deficient air from the more highly contaminated portion of the site being forced upward by the injected air. The change in oxygen levels indicates significant air movement through the soils, and it is likely that oxygenated air will reach all depths with continuous injection. Based on measured pressure response, which is an indicator of long-term oxygen transport, it is anticipated that the radius of influence for a long-term bioventing system at this site will exceed 30 feet. Monitoring during the extended pilot test at this site will better define the effective treatment radius.

### 3.4. In Situ Respiration Rates

The *in situ* respiration test was performed by injecting air (oxygen) into two MP screened intervals for a 12.5-hour period. Only two points were useable for this test due to the presence of water in the MPs which submerged the vapor probes. A 1-cubic-foot per minute air pump was used for air injection. Oxygen loss and other changes in soil vapor composition over time were then measured. Oxygen, TVH, and carbon dioxide were measured for a period of 30 hours following air injection. The results of *in situ* respiration testing at this site are presented in Figures 3.1 and 3.2.

The decline in percent oxygen over time measured at MPD-3.9 indicates an oxygen utilization rate of 0.009 percent per minute. There appeared to be little oxygen lost to abiotic reactions or non-fuel biodegradation. The percent oxygen measured at background point BG-2.5 remained essentially constant at 20 percent throughout the respiration test. Table 3.4 provides a summary of the oxygen utilization rates.

The magnitude of biological oxygen utilization and fuel degradation can be estimated based on initial pilot test results. A consistent oxygen deficiency in soil gas at the 3.5-foot BLS interval, as well as the steady uptake of oxygen at MPD-3.9

**TABLE 3.2**  
**PRESSURE RESPONSE (inches of water)**  
**AIR PERMEABILITY TEST**  
**SITE FT-03**  
**CHARLESTON AFB, SOUTH CAROLINA**

| Depth<br>(feet)       | MPA  |      | MPB  |      | MPC  |      | MPD |       |
|-----------------------|------|------|------|------|------|------|-----|-------|
|                       | 1.4  | 3.5  | 1.5  | 3.5  | 1.5  | 3.25 | 1.8 | 3.9   |
| Elapsed<br>Time (min) |      |      |      |      |      |      |     |       |
| 0                     | 0    | 0    | 0    | 0    | - a/ | -    | -   | -     |
| 0.25                  | -    | 3.5  | -    | 0    | -    | -    | -   | -     |
| 0.50                  | -    | 10.5 | -    | 0.4  | -    | -    | -   | -     |
| 1.0                   | -    | 19.0 | -    | 1.5  | -    | -    | -   | -     |
| 1.5                   | -    | 22   | -    | 2.8  | -    | -    | -   | 7.60  |
| 2                     | -    | 24   | -    | 4.2  | -    | 0.05 | -   | 8.90  |
| 3                     | -    | 25.5 | -    | 6.0  | -    | 0.07 | -   | 10.40 |
| 4                     | -    | -    | -    | 7.1  | -    | 0.10 | -   | -     |
| 5                     | -    | >25  | -    | 7.6  | -    | -    | -   | -     |
| 6                     | -    | -    | -    | 8.2  | 0.15 | 0.50 | -   | -     |
| 7                     | -    | -    | -    | 8.6  | 0.17 | 0.63 | -   | -     |
| 8                     | -    | -    | -    | 9.0  | 0.18 | 0.80 | -   | -     |
| 9                     | -    | -    | -    | 9.3  | 0.20 | 0.95 | -   | -     |
| 10                    | -    | >25  | -    | 9.4  | 0.21 | 1.12 | -   | -     |
| 11                    | -    | -    | -    | 9.5  | 0.23 | 1.26 | -   | -     |
| 12                    | -    | -    | -    | 9.6  | 0.24 | 1.4  | -   | -     |
| 13                    | -    | -    | -    | 9.7  | 0.25 | 1.52 | -   | -     |
| 14                    | -    | >25  | -    | 9.8  | 0.25 | 1.64 | -   | -     |
| 15                    | 7.21 | -    | -    | 10   | -    | -    | -   | -     |
| 16                    | -    | -    | -    | 10   | 0.27 | 1.88 | -   | -     |
| 18                    | -    | -    | -    | 10.2 | 0.27 | 2.09 | -   | -     |
| 20                    | -    | >25  | -    | 10.5 | 0.27 | 2.34 | -   | -     |
| 25                    | -    | -    | -    | 10.9 | 0.29 | 2.89 | -   | -     |
| 30                    | -    | >25  | -    | 11.1 | 0.31 | 3.32 | -   | -     |
| 35                    | -    | -    | -    | 11.4 | 0.32 | 3.72 | -   | -     |
| 38                    | 5.85 | >25  | -    | -    | -    | -    | -   | -     |
| 40                    | -    | -    | 1.65 | 11.6 | 0.33 | 4.11 | -   | -     |
| 45                    | -    | -    | 1.35 | 12.0 | 0.34 | 4.35 | -   | -     |
| 50                    | -    | -    | 1.39 | 12.4 | 0.35 | 4.55 | -   | -     |

**TABLE 3.2 (continued)**  
**PRESSURE RESPONSE (inches of water)**  
**AIR PERMEABILITY TEST**  
**SITE FT-03**  
**CHARLESTON AFB, SOUTH CAROLINA**

| Depth<br>(feet)       | MPA  |     | MPB  |      | MPC  |      | MPD   |       |
|-----------------------|------|-----|------|------|------|------|-------|-------|
|                       | 1.4  | 3.5 | 1.5  | 3.5  | 1.5  | 3.25 | 1.8   | 3.9   |
| Elapsed<br>Time (min) |      |     |      |      |      |      |       |       |
| 55                    | -    | >25 | 1.45 | 13.0 | 0.36 | 4.89 | -     | -     |
| 60                    | 7.73 | -   | 1.49 | 13.2 | 0.37 | -    | -     | -     |
| 64                    | -    | -   | -    | -    | -    | -    | 10.9  | -     |
| 65                    | -    | -   | 1.55 | 13.5 | -    | -    | -     | -     |
| 70                    | -    | -   | 1.60 | 13.8 | -    | -    | -     | -     |
| 71                    | 7.39 | -   | -    | -    | -    | -    | -     | -     |
| 75                    | -    | -   | 1.60 | 14.0 | -    | -    | -     | -     |
| 77                    | -    | -   | -    | -    | 0.39 | -    | -     | -     |
| 78                    | 7.68 | -   | -    | -    | -    | -    | -     | -     |
| 80                    | -    | -   | 1.62 | 14.4 | -    | -    | -     | -     |
| 82                    | -    | -   | -    | -    | 0.40 | -    | -     | -     |
| 90                    | -    | -   | 1.68 | 14.7 | -    | -    | -     | -     |
| 95                    | 8.06 | -   | -    | -    | 0.43 | -    | 11.43 | -     |
| 98                    | -    | -   | -    | -    | 0.43 | -    | -     | 13.83 |
| 100                   | -    | -   | 1.75 | 15.4 | 0.43 | -    | -     | -     |
| 105                   | -    | -   | -    | -    | 0.43 | -    | -     | -     |
| 110                   | 8.24 | >25 | 1.80 | 15.9 | -    | -    | -     | -     |
| 120                   | -    | -   | 1.83 | 16.2 | -    | -    | 11.80 | 14.16 |
| 122                   | 7.83 | >25 | -    | -    | -    | -    | -     | -     |
| 130                   | -    | -   | 3.3  | 17.0 | -    | -    | -     | -     |
| 134                   | 8.64 | -   | -    | -    | -    | -    | -     | -     |
| 140                   | -    | -   | 4.2  | 17.4 | -    | -    | -     | -     |
| 150                   | 8.63 | -   | 4.60 | 18.0 | -    | -    | -     | -     |
| 160                   | 8.74 | -   | 4.80 | 18.5 | -    | -    | 12.33 | 14.87 |
| 171                   | 8.75 | -   | 5.10 | 19.0 | -    | -    | -     | -     |
| 175                   | -    | -   | -    | -    | 0.52 | -    | -     | -     |
| 180                   | 8.78 | -   | >5.1 | 19.2 | -    | -    | -     | -     |

a/ - indicates measurement not taken at this time.

**TABLE 3.3**  
**INFLUENCE OF AIR INJECTION AT VENTING WELL**  
**ON MONITORING POINT OXYGEN LEVELS**  
**SITE FT-03**  
**CHARLESTON AFB, SOUTH CAROLINA**

| MP | Distance<br>From VW (ft) | Depth(ft) | Initial O <sub>2</sub> (%) | Final O <sub>2</sub> (%) <sup>a/</sup> |
|----|--------------------------|-----------|----------------------------|--|
| A  | 5                        | 1.4       | 9.9                        | 17.6                                   |
| B  | 10                       | 1.5       | 6.0                        | 11.5                                   |
| C  | 20                       | 1.5       | 12.2                       | 3.3                                    |
| D  | 10                       | 1.8       | 0.8                        | 0.8                                    |
| A  | 5                        | 3.5       | 0.0                        | 13.2                                   |
| B  | 10                       | 3.5       | 0.0                        | 0.2                                    |
| C  | 20                       | 3.25      | 0.0                        | -- b/                                  |
| D  | 10                       | 3.9       | 0.0                        | 13.7                                   |

a/ Reading taken at end of 3-hour air permeability test.  
b/ No reading due to high water in MP.

Figure 3.1  
 Respiration Test  
 Site FT-03 : Monitoring Point MPD-3.9  
 Charleston AFB, SC

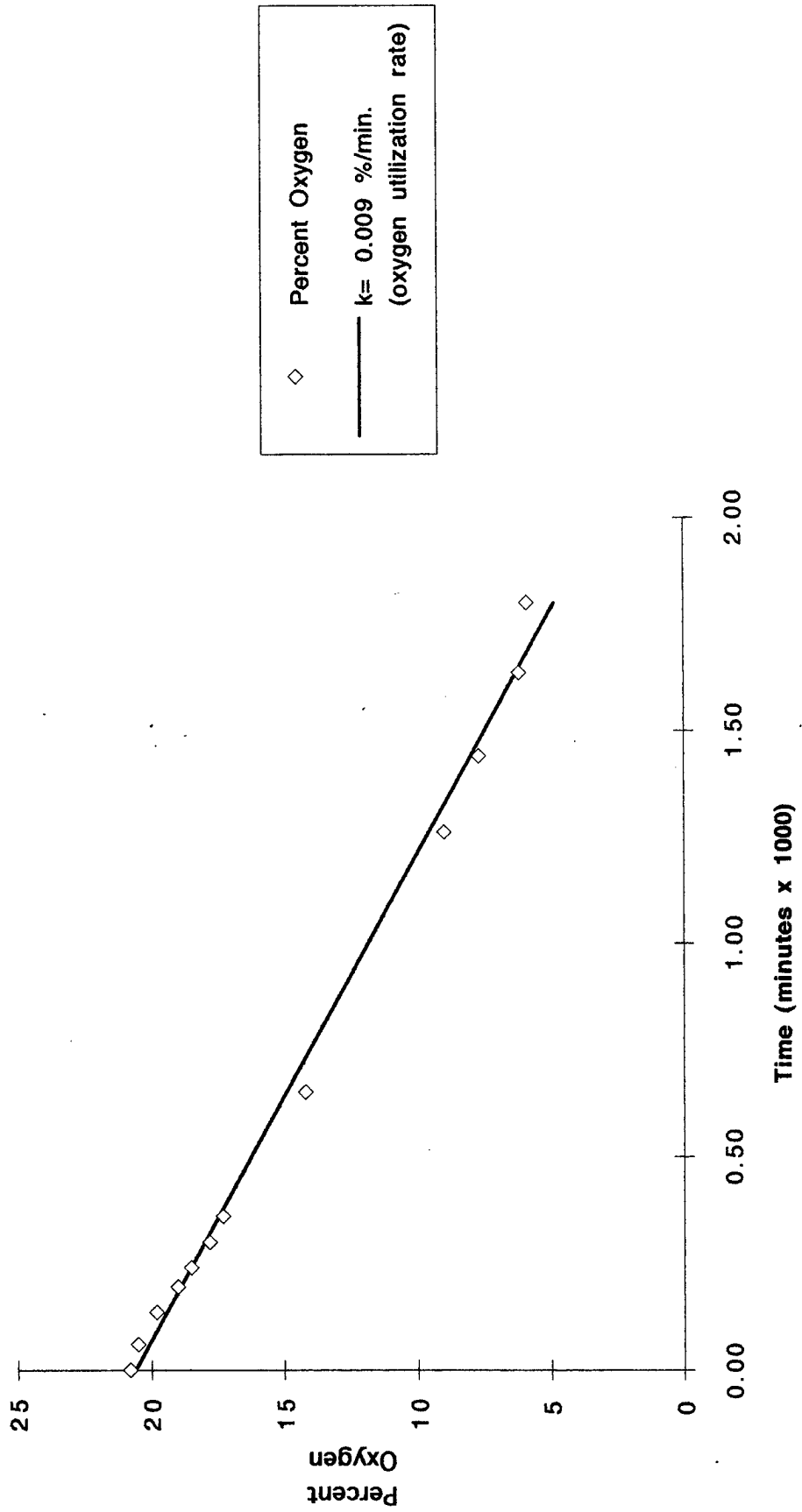
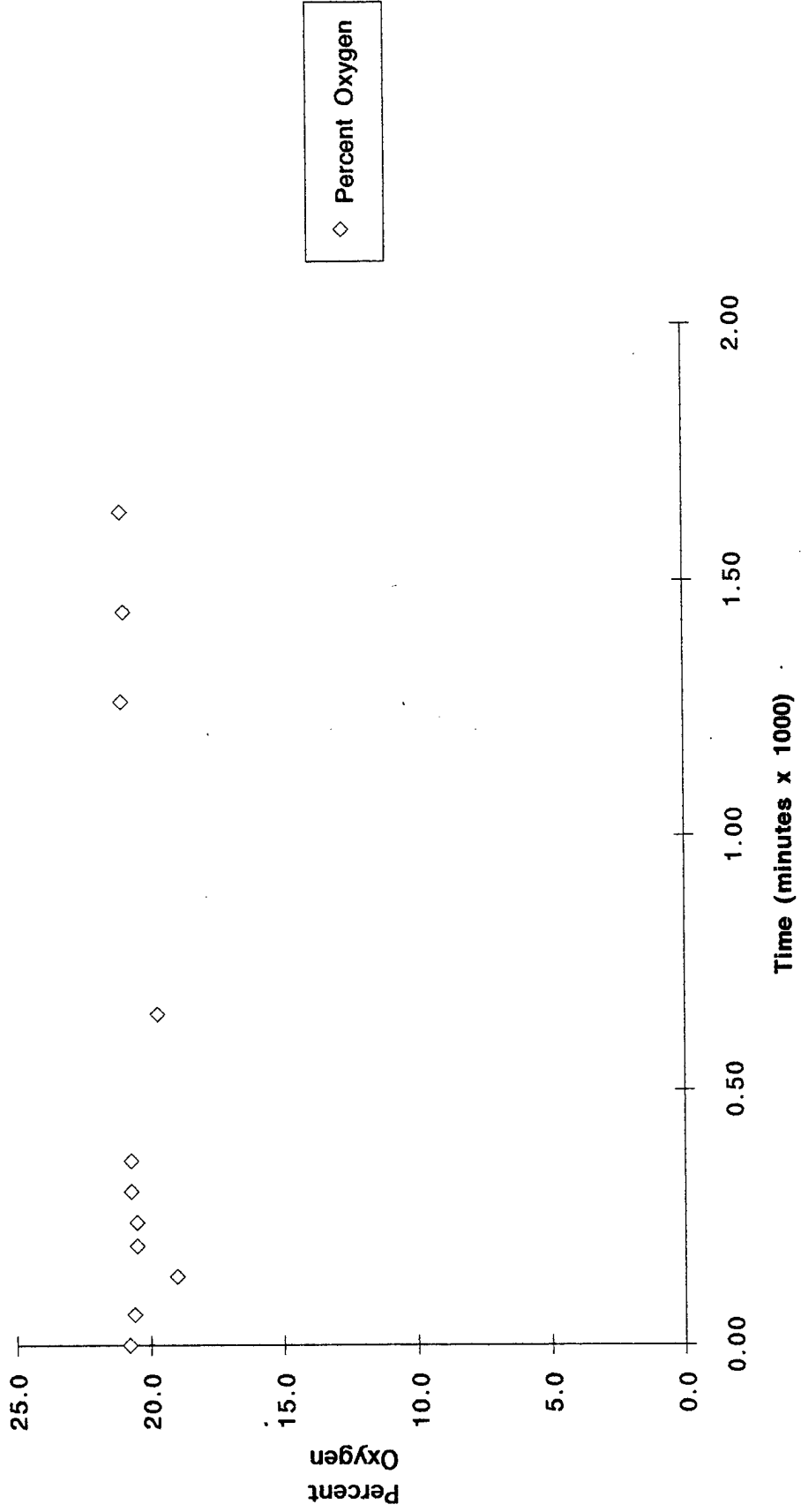

Figure 3.2  
Respiration Test  
Site FT-03 : Background Monitoring Point BG-2.5  
Charleston AFB, SC



**TABLE 3.4**  
**APPARENT OXYGEN UTILIZATION RATES**  
**SITE FT-03**  
**CHARLESTON AFB, SOUTH CAROLINA**

| MP      | Test<br>Duration<br>(min) | Apparent<br>O <sub>2</sub> loss<br>(%/min) |
|---------|---------------------------|--|
| MPD-3.9 | 1,800                     | 0.009                                      |
| BG-2.5  | 1,640                     | 0.000                                      |

as compared to the stable oxygen levels measured at the background MP, indicate that respiration and degradation of fuels will occur in the soils at this site when oxygen is supplied. Based on oxygen utilization rates observed at MPD-3.9, an estimated 600 to 900 milligrams (mg) of fuel per kilogram (kg) of soil can be degraded each year at this site. This estimate is based on an average air-filled porosity of 0.043 liter per kg of soil, and a conservative ratio of 3.5 mg of oxygen consumed for every 1 mg of fuel biodegraded.

### **3.5 Potential Air Emissions**

Soil concentrations of BTEX compounds detected ranged from nondetectable to 8.8 mg/kg. No benzene was detected in the soil analysis. The injection rate of 50 scfm was reduced by 75 percent to approximately 12-15 scfm to minimize initial VOC emissions. Emissions should rapidly decrease as accumulated vapors move outward from the injection point and are biodegraded as they move through the soil. Some loss of vapors to the atmosphere is expected due to the shallow nature of this contamination. However, the low injection rate and limited BTEX in these soils should result in a total BTEX emission of no more than 8 pounds during the 1 year pilot test.

### **4.0 RECOMMENDATIONS**

Initial bioventing tests at this site indicate that oxygen has been depleted in the contaminated soils, and that air injection is an effective method of increasing aerobic fuel biodegradation. The Air Force Center for Environmental Excellence (AFCEE) has recommended that air injection continue at this site to determine the long-term radius of oxygen influence and the effects of time, available nutrients, and changing temperatures on fuel biodegradation rates.

A small, 1-horsepower regenerative blower has been installed at the site to continue a rate of air injection of approximately 10-15 scfm. Soil gas samples will be collected in late January or early February, if groundwater levels drop and permanent soil gas monitoring points are not submerged. In March 1993, ES will return to the site to sample and analyze the soil gas and conduct a repeat respiration test. In November 1993, a final respiration test will be conducted, and soil and soil gas samples will be collected from the site to determine the degree of remediation achieved during the first year of *in situ* treatment.

Based on the results of the first year of pilot-scale bioventing, AFCEE will recommend one of two options:

1. Upgrade, if necessary, and continue operation of the bioventing system for full-scale remediation of the site. AFCEE can assist the Base in obtaining regulatory approval for upgrading and continued operation.
2. If final soil sample analytical results indicate significant contaminant removal has occurred, AFCEE may recommend additional sampling to confirm that cleanup criteria have been achieved.

## 5.0 REFERENCES

Hinchee, R.E., S.K. Ong, R.N. Miller, D.C. Downey, and R. Frandt. 1992. *Test Plan and Technical Protocol for a Field Treatability Test for Bioventing*. Prepared for Air Force Center for Environmental Excellence. May. Denver, Colorado.

Engineering-Science, Inc. 1992. *Field Sampling Plan for AFCEE Bioventing*. Denver, Colorado.

APPENDIX A  
O&M CHECKLIST

## **SYSTEM MAINTENANCE**

### **B.1 BLOWER/MOTOR MAINTENANCE**

The blower and motor are relatively maintenance free. There is no lubrication required because the blower and motor have sealed bearings. If a blower system is in need of repair, please contact Grant Watkins at (919) 677-0080.

### **B.2 FILTER MAINTENANCE**

To avoid damage caused by passing solids through the blower, an air filter has been installed inline before the blower. By design, Gast® regenerative blowers are able to ingest small quantities of particles without damage. However, continuous ingestion of solids will damage or imbalance the impellers. The inline air filter will prevent solids from entering the blower, and is rated at 99 percent efficiency to 10 microns.

The filter element is a polyester cloth and can be cleaned and reused, or replaced. The filter should be checked weekly for the first two months of operation. The air filter should be cleaned or replaced when the pressure difference across the filter reaches 15 to 20 inches of water. It is the responsibility of Charleston AFB to determine the best schedule for filter cleaning and/or replacement, depending on the results of the initial observations.

The filter can be checked after turning off the blower system. To remove the filter, loosen the clamps, lift the metal top off the air filter, and lift the air filter from the metal housing. When replacing the filter, be careful that the rubber seals remain in place. The filter is manufactured by Solberg Manufacturing, Inc. in Itasca, Illinois. Their phone number is (708) 773-1363. The filters can also be obtained through Fluid Technology, Inc. in Denver, Colorado. The contacts there are Mr. Bob Cook and Mr. Greg Sparks; they can be reached at (303) 233-7400. It is recommended that Charleston AFB keep a spare air filter at the site.

### **B.3 BLOWER PERFORMANCE MONITORING**

To monitor the blower performance, vacuum, pressure, and temperature will be measured. These data will be recorded on the data collection sheets provided. All measurements will be taken at the same time while the system is running.

### **B.3.1 Pressure/Vacuum**

Open the shed roof and record the pressure and vacuum readings directly from the gages in inches of water. Record the measurements on the data collection sheet provided.

### **B.3.2 Temperature**

Open the shed roof and record the temperature readings directly from the gages in degrees Fahrenheit. Record the measurements on the data collection sheet provided.

## **B.4 MONITORING SCHEDULE**

The following monitoring schedule is recommended for this system. During the initial months of operation, more frequent monitoring is recommended to ensure that any start up problems are quickly corrected. Data collection sheets have been provided to record the system data.

### Monitoring Item

Blower vacuum and temperature

### Monitoring Frequency

Weekly for the first 2 months of operation. Charleston AFB personnel then may optimize the schedule depending on the results of initial observations.



**APPENDIX B**  
**CHAIN-OF-CUSTODY FORM**

