

LOAN DOCUMENT

PHOTOGRAPH THIS SHEET

0

DTIC ACCESSION NUMBER

LEVEL

INVENTORY

Bioventing Pilot Test Work Plan for...

DOCUMENT IDENTIFICATION
Apr 96

DISTRIBUTION STATEMENT A
Approved for Public Release
Distribution Unlimited

DISTRIBUTION STATEMENT

DATE ACCESSIONED

DATE RETURNED

REGISTERED OR CERTIFIED NUMBER

ACCESSION ID#	
NTIS	GRAM <input type="checkbox"/>
DTIC	TRAC <input type="checkbox"/>
UNANNOUNCED	<input type="checkbox"/>
JUSTIFICATION	<input type="checkbox"/>
BY	
DISTRIBUTION/	
AVAILABILITY CODES	
DISTRIBUTION	AVAILABILITY AND/OR SPECIAL
A-1	

DISTRIBUTION STAMP

20001215 094

DATE RECEIVED IN DTIC

H
A
N
D
L
E

W
I
T
H

C
A
R
E

PHOTOGRAPH THIS SHEET AND RETURN TO DTIC-FDAC

Table data from
McCall + Eddy 1995 ✓

FINAL

Bioventing Pilot Test Work Plan for Closed Waste POL Pit, SWMU 14 Fort Rucker, Alabama

Prepared For



**The US Army Environmental Center
Aberdeen Proving Ground, Maryland**

Fort Rucker, Alabama

and



**Air Force Center for Environmental Excellence
Brooks Air Force Base
San Antonio, Texas**

April 1996



**PARSONS
ENGINEERING SCIENCE, INC.**

1700 Broadway, Suite 900 • Denver Colorado 80290

AQM01-03-0546

DEFENSE TECHNICAL INFORMATION CENTER
REQUEST FOR SCIENTIFIC AND TECHNICAL REPORTS

Title AFCEE Collection

1. Report Availability (Please check one box)

- This report is available. Complete sections 2a - 2f.
- This report is not available. Complete section 3.

2a. Number of Copies Forwarded

each

2b. Forwarding Date

July/2000

2c. Distribution Statement (Please check ONE box)

DoD Directive 5230.24, "Distribution Statements on Technical Documents," 18 Mar 87, contains seven distribution statements, as described briefly below. Technical documents MUST be assigned a distribution statement.

- DISTRIBUTION STATEMENT A: Approved for public release. Distribution is unlimited.
- DISTRIBUTION STATEMENT B: Distribution authorized to U.S. Government Agencies only.
- DISTRIBUTION STATEMENT C: Distribution authorized to U.S. Government Agencies and their contractors.
- DISTRIBUTION STATEMENT D: Distribution authorized to U.S. Department of Defense (DoD) and U.S. DoD contractors only.
- DISTRIBUTION STATEMENT E: Distribution authorized to U.S. Department of Defense (DoD) components only.
- DISTRIBUTION STATEMENT F: Further dissemination only as directed by the controlling DoD office indicated below or by higher authority.
- DISTRIBUTION STATEMENT X: Distribution authorized to U.S. Government agencies and private individuals or enterprises eligible to obtain export-controlled technical data in accordance with DoD Directive 5230.25, Withholding of Unclassified Technical Data from Public Disclosure, 6 Nov 84.

2d. Reason For the Above Distribution Statement (in accordance with DoD Directive 5230.24)

2e. Controlling Office

HQ AFCEE

2f. Date of Distribution Statement Determination

15 Nov 2000

3. This report is NOT forwarded for the following reasons. (Please check appropriate box)

- It was previously forwarded to DTIC on _____ (date) and the AD number is _____
- It will be published at a later date. Enter approximate date if known. _____
- In accordance with the provisions of DoD Directive 3200.12, the requested document is not supplied because: _____

Print or Type Name

Laura Peña

Signature

Laura Peña

Telephone

210-536-1431

(For DTIC Use Only)

AQ Number M01-03-0546

**FINAL
BIOVENTING PILOT TEST WORK PLAN FOR
CLOSED WASTE POL PIT, SWMU 14
FORT RUCKER, ALABAMA**

APRIL 1996

Prepared for:

**US Army Environmental Center
Aberdeen Proving Ground, Maryland**

**Environmental and Natural Resources Division
ATZQ-DPW-EN
Fort Rucker, Alabama**

and

**Air Force Center for Environmental Excellence
Brooks AFB, Texas**

Prepared by:

**Parsons Engineering Science, Inc.
1700 Broadway, Suite 900
Denver, Colorado 80290**

TABLE OF CONTENTS

	<u>Page</u>
1.0 INTRODUCTION.....	1
2.0 SITE DESCRIPTION.....	3
2.1 Site Location and History	3
2.2 Site Geology and Hydrogeology	3
2.3 Site Contaminants	6
3.0 PILOT TEST ACTIVITIES	7
3.1 Layout of Pilot Test Components	7
3.2 Vent Well Installation.....	7
3.3 Monitoring Point Installations	9
3.4 Background Monitoring Point	9
3.5 Soil and Soil Gas Sampling	9
3.5.1 Soil Sampling	9
3.5.2 Soil Gas Sampling	12
3.6 Handling of Investigation-Derived Waste.....	12
3.7 Blower System	12
3.8 <i>In Situ</i> Respiration Test.....	14
3.9 Air Permeability Test	14
3.10 Installation of Extended Pilot Test Bioventing System.....	14
4.0 EXCEPTIONS TO PROTOCOL PROCEDURES	15
5.0 FACILITY SUPPORT REQUIREMENTS.....	15
5.1 Test Preparation Support	15
5.2 Initial Testing Support	15
5.3 Extended Testing Support.....	16
6.0 PROJECT SCHEDULE	16
7.0 POINTS OF CONTACT	17
8.0 REFERENCES	18

TABLE OF CONTENTS (Continued)

FIGURES

	<u>Page</u>
1.1 Location of Site With Respect to Facility.....	2
2.1 Site Vicinity Map.....	4
2.2 Hydrogeologic Cross-Section A-A'	5
3.1 Proposed Bioventing System Layout	8
3.2 Proposed Injection Vent Well Construction Detail	10
3.3 Proposed Monitoring Point Construction Detail	11
3.4 Proposed Blower System Instrumentation Diagram for Air Injection.....	13

**FINAL
BIOVENTING PILOT TEST WORK PLAN FOR
CLOSED WASTE POL PIT, SWMU 14
FORT RUCKER, ALABAMA**

1.0 INTRODUCTION

This work plan presents the scope of a multiphase bioventing pilot test for *in situ* treatment of fuel-contaminated soils at the closed waste petroleum, oils, and lubricants (POL) pit, which has been designated Solid Waste Management Unit (SWMU) 14, located at Fort Rucker, Alabama. The location of SWMU 14 with respect to the Fort is shown on Figure 1.1. The pilot test will be performed by Parsons Engineering Science, Inc. (Parsons ES) for Fort Rucker and the United States Army Environmental Center (USAEC) through a contract with the Air Force Center for Environmental Excellence (AFCEE). The primary objectives of the proposed pilot test are to:

- Assess the potential for supplying oxygen throughout the contaminated soil interval;
- Determine the rate at which indigenous microorganisms will degrade fuel when supplied with oxygen-rich soil gas;
- Evaluate the potential for sustaining these rates of biodegradation until fuel contamination is remediated to concentrations below regulatory standards; and if appropriate,
- Determine design parameters, such as well spacing and air flow rates, for full-scale bioventing system design.

The pilot test will be conducted in two phases. The initial phase will consist of construction of one air injection vent well (VW) and four vapor monitoring points (MPs), *in situ* respiration tests, an air permeability test, and installation of a blower system for air injection. This initial testing is expected to take approximately 2 weeks. During the second phase, the bioventing system will be operated and monitored over a 1-year period.

An initial pilot test results report will be prepared following completion of the initial phase of testing. This report will summarize the test results and make specific recommendations for continued system operation and/or expansion. If the initial phase of testing proves bioventing to be an effective means of remediating soil contamination at this site, pilot test data will be used to prepare a conceptual full-scale design and cost estimate, and to estimate the time required for site cleanup.

Additional background information on the development and recent success of the bioventing technology is found in documents entitled *Test Plan and Technical Protocol for a Field Treatability Test for Bioventing* (Hinchee *et al.*, 1992) and *Principles and Practices of Bioventing* (Leeson *et al.*, 1995). The protocol document (Hinchee *et al.*,

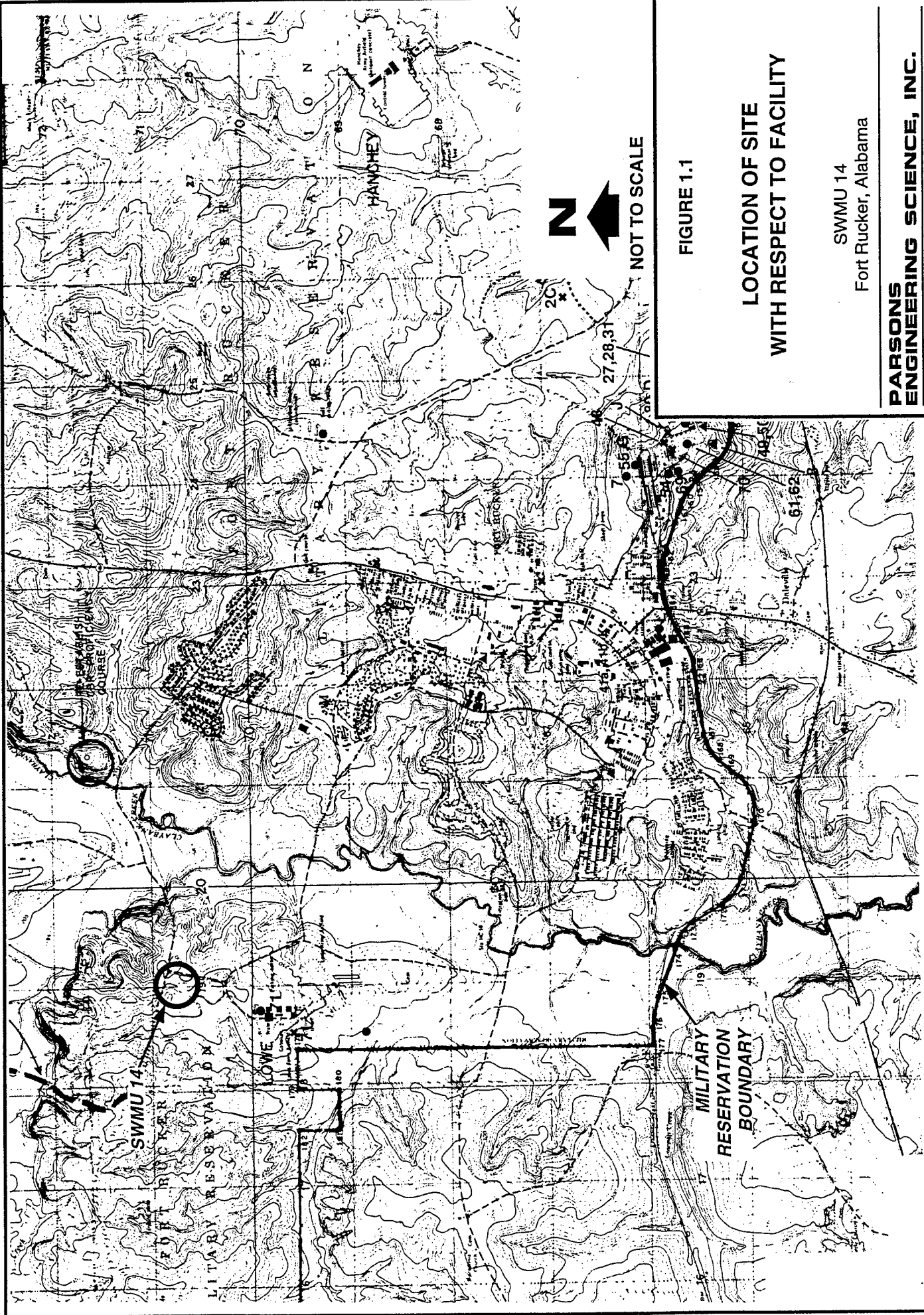

FIGURE 1.1

**LOCATION OF SITE
WITH RESPECT TO FACILITY**

SWMU 14
Fort Rucker, Alabama

**PARSONS
ENGINEERING SCIENCE, INC.**
Denver, Colorado

Source: US Army Corps of Engineers Reservation Map, July 1983.

1992) will serve as the primary reference for pilot test well designs and the detailed procedures to be used during the test.

2.0 SITE DESCRIPTION

2.1 Site Location and History

This and the following two sections summarize information presented in the Phase II Resource Conservation and Recovery Act (RCRA) Facility Investigation (RFI) Final Report (Metcalf & Eddy, Inc., 1995). SWMU 14 is located in the western portion of Fort Rucker (Figure 1.1) approximately 1,200 feet west-southwest of the intersection of Faulkner Road and Lowe Field Road, as shown on Figure 2.1. The site is located on a ridge, and the land slopes to the west-southwest. The nearest surface water, a tributary stream to Claybank Creek, is located approximately 1,000 feet west of the site.

During the period from 1978 to 1980, the POL pit was used to dispose of contaminated helicopter fuel (JP-4), tanker truck washout fluids, and possibly motor oil. The unlined pit was about 80 feet in diameter and 7 feet deep. The closed POL pit is now covered with soil and vegetated with pine trees.

In 1980, soil samples taken from the pit showed traces of trichloroethene. Fort Rucker subsequently notified the United States Environmental Protection Agency (USEPA) and the State of Alabama of the existence of the pit and the analytical results. Both agencies recommended immediate closure. The pit was closed by adding clay to absorb the waste POL material, and the top was mounded to promote surface runoff. Although the active pit was about 80 feet in diameter, the pit boundary shown on Figure 2.1 represents the area covered with clay, which is larger than the former active disposal pit. Closure was approved by the state and USEPA and was completed in 1981 (Army Environmental Hygiene Agency [AEHA], 1986). In June 1990, the site was planted with sapling pine trees (Metcalf & Eddy, Inc., 1995).

An RFI was performed in 1991 to determine whether release of hazardous constituents to the groundwater had occurred at the site. Four groundwater monitoring wells (14-G1 through 14-G4, Figure 2.1) were installed crossgradient and downgradient from the closed pit. Because benzene and six RCRA metals were detected in groundwater samples, a Phase II RFI was performed in 1995. The Phase II investigation included installing and sampling five additional groundwater monitoring wells (14-G5 through 14-G9, Figure 2.1) in the vicinity of the closed POL pit (Metcalf & Eddy, Inc., 1995).

2.2 Site Geology and Hydrogeology

Because bioventing technology is applied to unsaturated soils, this section will discuss primarily soils above the groundwater surface. The geology of SWMU 14, as shown on Figure 2.2 and described in this section, was determined from soil samples collected during monitoring well installation (Metcalf & Eddy, Inc., 1995). SWMU 14 is underlain by unconsolidated deposits consisting primarily of silty sand containing

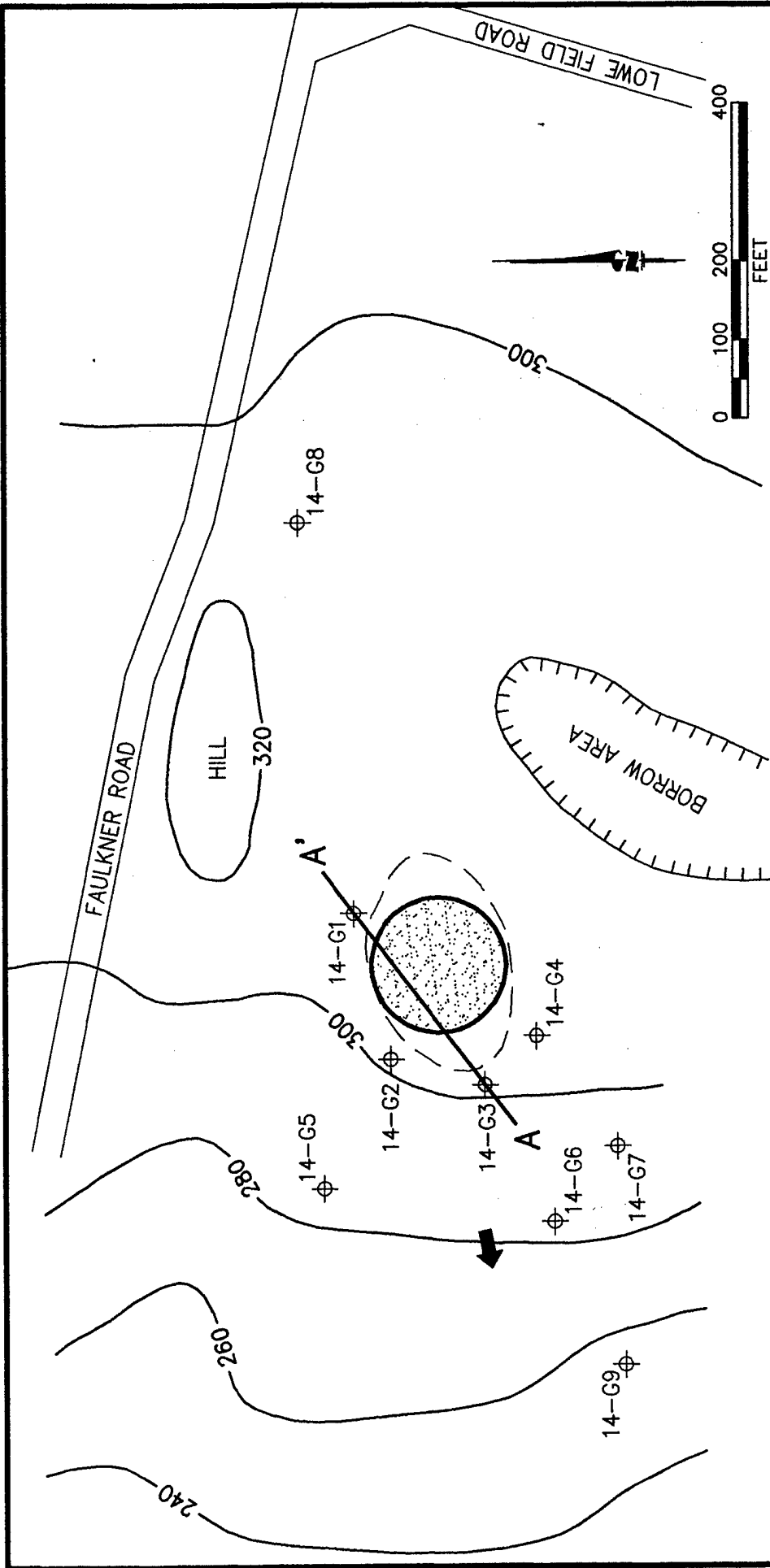

- APPROXIMATE BOUNDARY OF CLAY/ SOIL COVER OVERLYING FORMER WASTE PIT
- 14-G3 ϕ EXISTING GROUNDWATER MONITORING WELL
- 300- PROPOSED BIOVENTING PILOT TEST AREA
- APPROXIMATE GROUNDWATER FLOW DIRECTION
- A—A'** LOCATION OF CROSS-SECTION A-A' (FIGURE 2.2)

FIGURE 2.1

SITE VICINITY MAP

SWMU 14
Fort Rucker, Alabama

**PARSONS
ENGINEERING SCIENCE, INC.**
Denver, Colorado

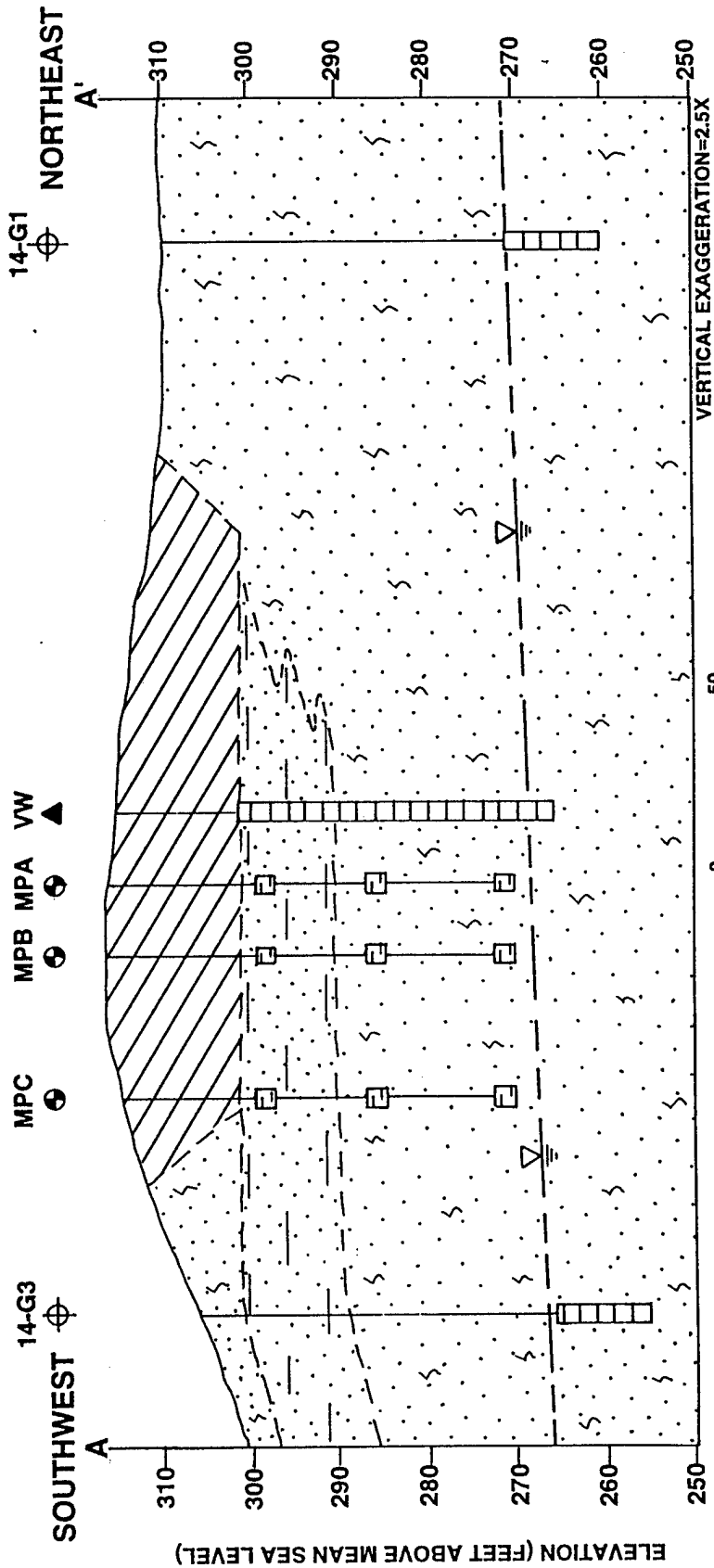

LITHOLOGIC DESCRIPTION

- CLAY AND SOIL
- SILTY SAND
- CLAYEY SAND

LEGEND

- 14-G3
- 14-G1
- MPC
- MPB
- MPA
- VW
- EXISTING GROUNDWATER MONITORING WELL
- PROPOSED VAPOR MONITORING POINT
- PROPOSED AIR INJECTION VENT WELL
- GROUNDWATER SURFACE DASHED WHERE INFERRED
- GEOLOGIC CONTACT, DASHED WHERE INFERRED
- SCREENED INTERVAL

NOTE: VW AND MP's PROJECTED INTO PLANE OF CROSS-SECTION

FIGURE 2.2

HYDROGEOLOGIC CROSS-SECTION A-A'

SWMU 14
Fort Rucker, Alabama

PARSONS ENGINEERING SCIENCE, INC.
Denver, Colorado

between 6 and 21 percent silt. Downgradient (west) from the site, a clayey sand (25 percent clay) layer approximately 11 to 14 feet thick was encountered between 3 and 7 feet below ground surface (bgs). Because no soil borings were drilled in the former pit, it is unknown if, or how far, this clayey sand layer extends beneath the closed pit.

Groundwater occurs under unconfined (water table) conditions. The depth to groundwater, measured in January 1994, ranged from 36 to 40 feet bgs in the immediate vicinity of the former pit. In January 1994, groundwater was flowing toward the west with a potentiometric surface gradient of 0.006 foot per foot (ft/ft) (Metcalf & Eddy, Inc., 1995).

2.3 Site Contaminants

Surface soils and groundwater were sampled during the SMWU 14 site investigations (Metcalf & Eddy, Inc., 1995). Bioventing technology is applicable to remediating petroleum-hydrocarbon-contaminated soil; however, because subsurface soil data are not available, inferences regarding vadose zone contamination are drawn from groundwater analytical results. The primary contaminants detected in groundwater at this site are metals and fuel-related petroleum hydrocarbons.

Historical information indicates that the source of site contaminants was waste solvents, fuel, and other petroleum hydrocarbons that were disposed of in the former unlined POL pit. Although a variety of volatile organic compounds (VOCs) and semivolatile organic compounds (SVOCs) were detected in groundwater samples, the most frequently detected compounds were benzene and xylenes. Benzene concentrations ranged from 16.5 to 400 micrograms per liter ($\mu\text{g/L}$), and total xylenes concentrations ranged from 31 to 2,000 $\mu\text{g/L}$. The highest concentrations of both benzene and total xylenes were detected in groundwater samples from well 14-G4, located on the downgradient edge of the former disposal pit (Figure 2.1). At the time of the Phase II investigation in 1995, the VOC plume extended downgradient approximately 600 feet and was 300 feet wide (Metcalf & Eddy, Inc., 1995).

Four surface soil samples were collected in the vicinity of the closed waste POL pit. Concentrations of inorganic analytes were consistent with the criterion background soil concentrations except for barium, chromium, and vanadium. Concentrations of barium ranged from less than 5.18 micrograms per kilogram ($\mu\text{g/kg}$) to 24.3 $\mu\text{g/kg}$, concentrations of chromium ranged from 6.26 to 19.8 $\mu\text{g/kg}$, and concentrations of vanadium ranged from 23.1 to 33.4 $\mu\text{g/kg}$. No organic analyte concentrations exceeded regulatory action levels.

Although subsurface soils were not investigated, groundwater results and historic information indicate that significant concentrations of petroleum hydrocarbons may be present in the soils beneath the former pit area. Because the former pit was unlined, and the sandy soils have a relatively high permeability, much of the disposed hydrocarbon wastes likely infiltrated downward through the soils beneath the former pit. Additionally, relatively high concentrations of fuel hydrocarbons detected in the groundwater immediately downgradient from the closed waste POL pit suggest that significant concentrations of hydrocarbons remain in the soil and are acting as a continuing groundwater source of these contaminants. As described in the following

sections, air (oxygen) injection into these soils should stimulate biodegradation of these residual hydrocarbons.

3.0 PILOT TEST ACTIVITIES

The purpose of this section is to describe the pilot test activities proposed for SWMU 14. The proposed locations and construction details for the VW and MPs are discussed. The blower configuration that will be used to inject air (oxygen) into contaminated soils is also discussed in this section. Finally, a brief description of the pilot test procedures is provided.

3.1 Layout of Pilot Test Components

A general description of criteria for siting a central VW and vapor MPs is included in the protocol document (Hinchee *et al.*, 1992). Figure 3.1 illustrates the proposed locations of the VW and three MPs at this site, and Figure 2.2 shows the proposed vertical positions of the VW and MP screened intervals relative to the site lithology. Based on historical information, previous site investigation data, and a site visit, the VW should be located near the center of the clay fill. The final locations of these pilot test components may vary slightly from the proposed locations if significant fuel contamination is not observed in the boring for the VW. Soils in this area are expected to be contaminated with petroleum hydrocarbons and depleted in oxygen content (< 2%). Based on these site conditions, biological activity should be stimulated by oxygen-rich soil gas ventilation during pilot test operations.

The potential radius of venting influence around the VW is expected to be 60 to 80 feet. This estimate is based on Parsons ES experience with similar site conditions where moderate- to high-permeability fuel-contaminated soils are present within the unsaturated zone, and fine-grained soils, which reduce short-circuiting of injected air to the surface, are present near the ground surface. Three MPs (MPA, MPB, and MPC) will be installed within a 80-foot radius of the central VW (Figure 3.1). An additional MP will be installed adjacent to the existing monitoring well 14-G8 (Figure 2.1), and will be used to measure the composition of background soil gas.

3.2 Vent Well Installation

The VW will be constructed of 4-inch-diameter, Schedule 40 polyvinyl chloride (PVC), with an estimated 35-foot interval of 0.04-inch slotted screen set at approximately 15 to 50 feet bgs. The bottom of the well screen will be set 2 to 4 feet below the groundwater table to ensure oxygenation throughout deep vadose zone soils during seasonal depression of the groundwater table. Flush-threaded PVC casing and screen with no organic solvents or glues will be used. The filter pack will be clean, well-rounded silica sand with a 6-9 grain size and will be placed in the annular space to 1 foot above the screened interval. A 4-foot-thick bentonite seal will be placed directly over the filter pack to produce an air-tight seal above the screened interval. The bentonite seal, consisting of granular bentonite, will be placed in 6-inch layers, with each layer hydrated in place with potable water prior to the addition of subsequent layers. The remaining annular space will then be filled with a bentonite/cement grout. A complete seal is critical to prevent injected air from short-

APPROXIMATE BOUNDARY
OF CLAY COVER OVERLYING
FORMER WASTE POL PIT

APPROXIMATE LOCATION OF PROPOSED
OVERHEAD ELECTRICAL WIRES (BY FORT RUCKER)
TO EXISTING POWER LINES ALONG FAULKNER ROAD

BACKGROUND MP
LOCATED ADJACENT TO
MW-14G8

PROPOSED POWER POLE LOCATION
BY FORT RUCKER

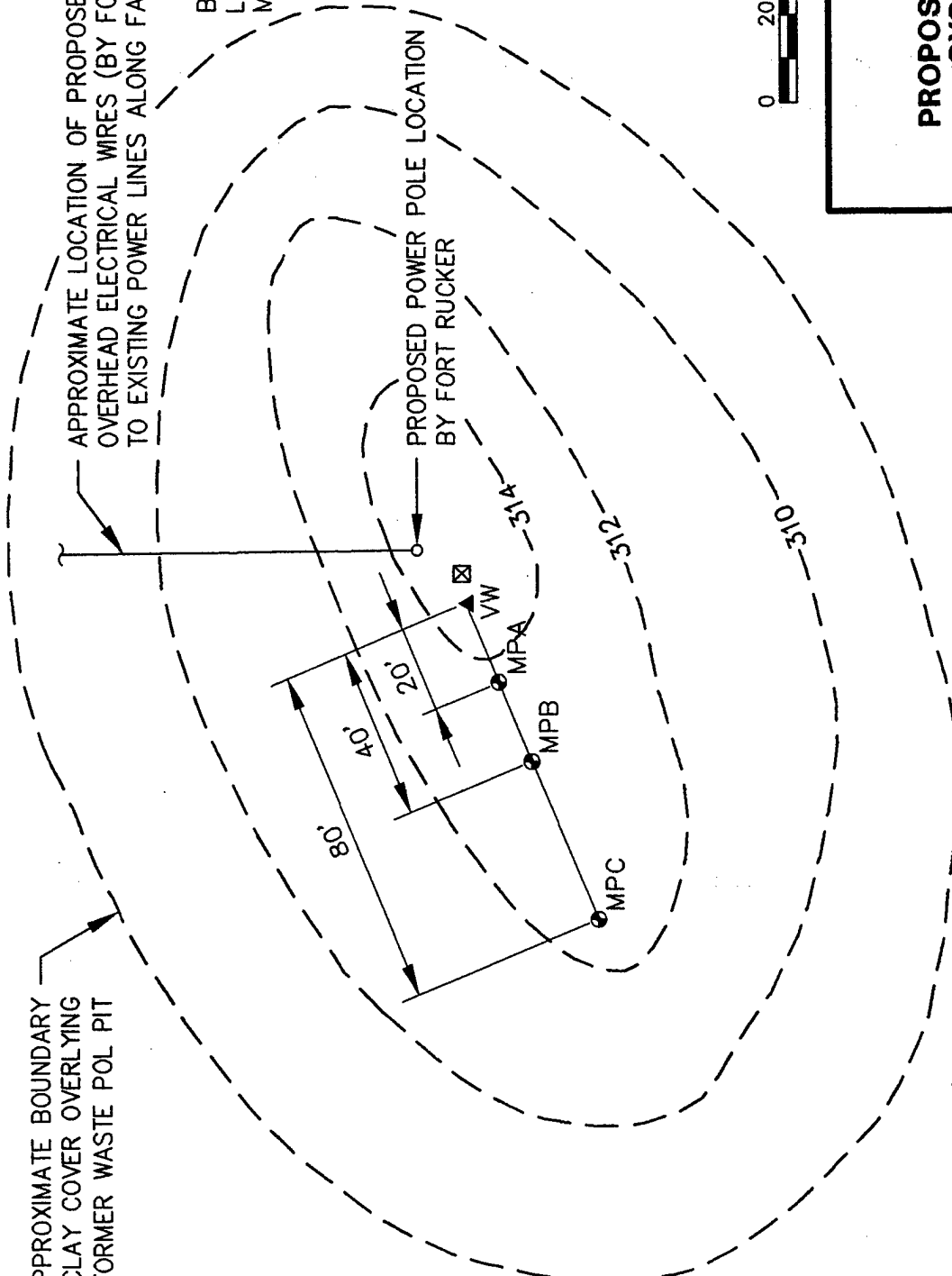

FIGURE 3.1

**PROPOSED BIOVENTING
SYSTEM LAYOUT**

SWMU 14
Fort Rucker, Alabama

**PARSONS
ENGINEERING SCIENCE, INC.**

Denver, Colorado

LEGEND

- ▲ PROPOSED AIR INJECTION VENT WELL
- PROPOSED VAPOR MONITORING POINT
- ▣ PROPOSED BLOWER SYSTEM
- APPROXIMATE SURFACE CONTOUR LOCATION
(FEET ABOVE MEAN SEA LEVEL)

circuiting to the surface during the bioventing test. Figure 3.2 illustrates the proposed VW construction detail for this site.

3.3 Monitoring Point Installations

A typical multi-depth vapor MP installation for this site is shown in Figure 3.3. Soil gas oxygen, carbon dioxide, and total volatile hydrocarbon (TVH) concentrations will be monitored at depths of approximately 15 feet, 30 feet, and 40 feet bgs at each location. Soil temperature will be monitored using thermocouples installed at depths of 15 feet and 40 feet at MPA. Multi-depth monitoring will confirm that the entire soil profile is receiving oxygen and will be used to measure fuel biodegradation rates at the three depths.

Each MP will be constructed with three vapor probes. The vapor probes, constructed of 6-inch-long sections of 1-inch-diameter PVC well screen, will be placed within a 2-foot layer of 6-9 silica sand. The annular spaces between the three screened MP intervals will be sealed with bentonite to isolate the monitoring intervals. The bentonite seals will consist of granular bentonite hydrated in place. The bentonite will be placed in 6-inch layers and hydrated with potable water prior to placement of subsequent layers to assure complete saturation of the bentonite. Additional details on VW and MP construction are presented in Section 4 of the protocol document (Hinchee *et al.*, 1992).

3.4 Background Monitoring Point

The construction of an additional vapor MP will be required to measure background levels of oxygen and carbon dioxide and to determine if natural carbon sources are contributing to oxygen uptake during the *in situ* respiration test described in Section 3.8. The background well will be installed in an area of uncontaminated soil and in the same stratigraphic formation as the MPs to be installed at the closed waste POL pit. The background well will be similar in construction to the other MPs (Figure 3.3).

3.5 Soil and Soil Gas Sampling

3.5.1 Soil Sampling

Six soil samples will be collected from the pilot test area during installation of boreholes for the VW and MPs. Additionally, one soil sample will be collected from the background MP. Sampling procedures will follow those outlined in the protocol document. A total hydrocarbon vapor analyzer will be used during drilling to screen split-spoon samples for intervals of significant fuel contamination. Based on field screening results, six soil samples from the most contaminated intervals will be analyzed for total recoverable petroleum hydrocarbons (TRPH), and benzene, toluene, ethylbenzene, and xylenes (BTEX). Three of the samples also will be analyzed for soil moisture, pH, particle sizing, alkalinity, total iron, and nutrients. The background soil sample will be analyzed for total Kjeldahl nitrogen (TKN). TRPH and BTEX analyses will be performed using USEPA Methods SW8015 and SW8020, respectively.

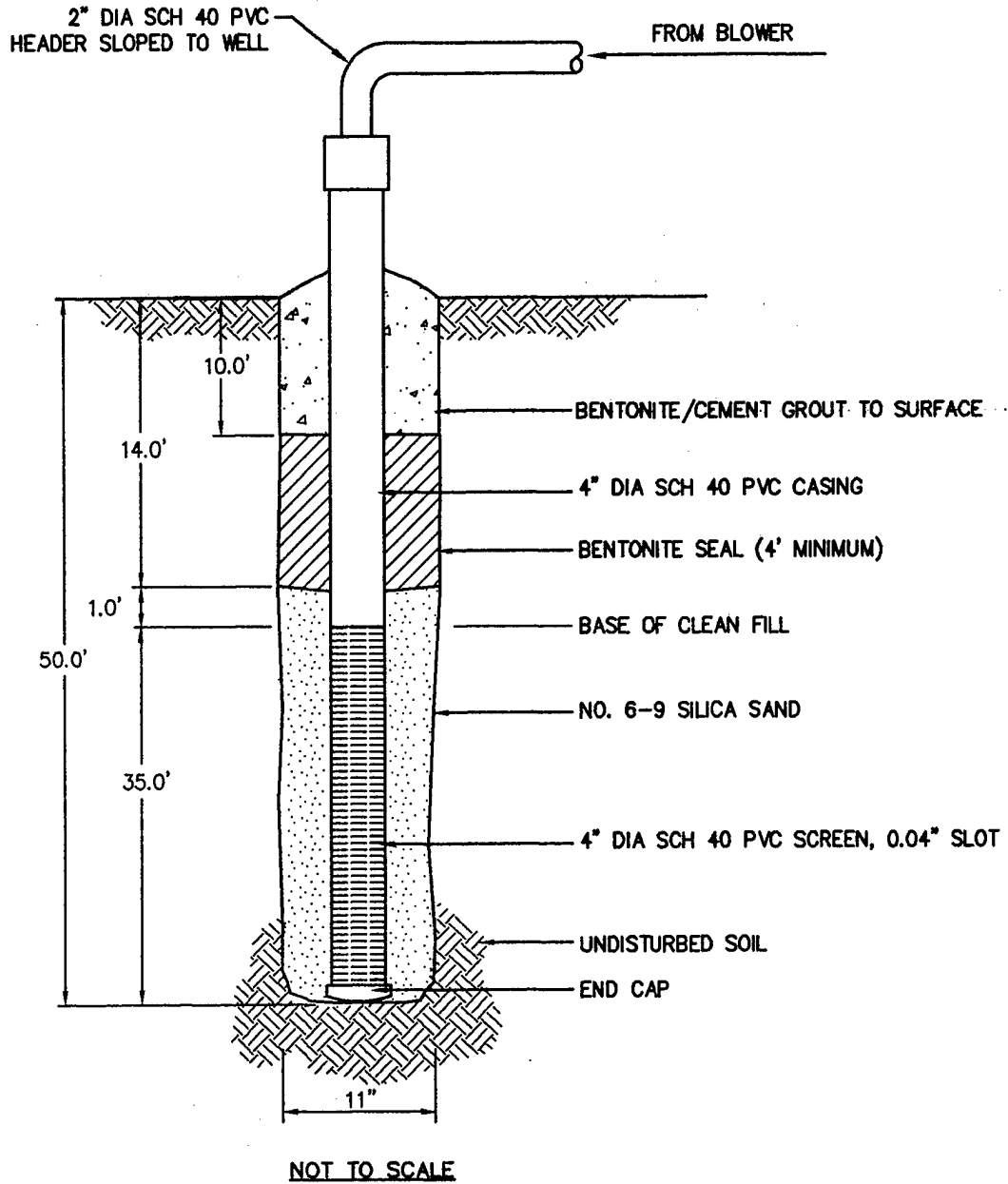
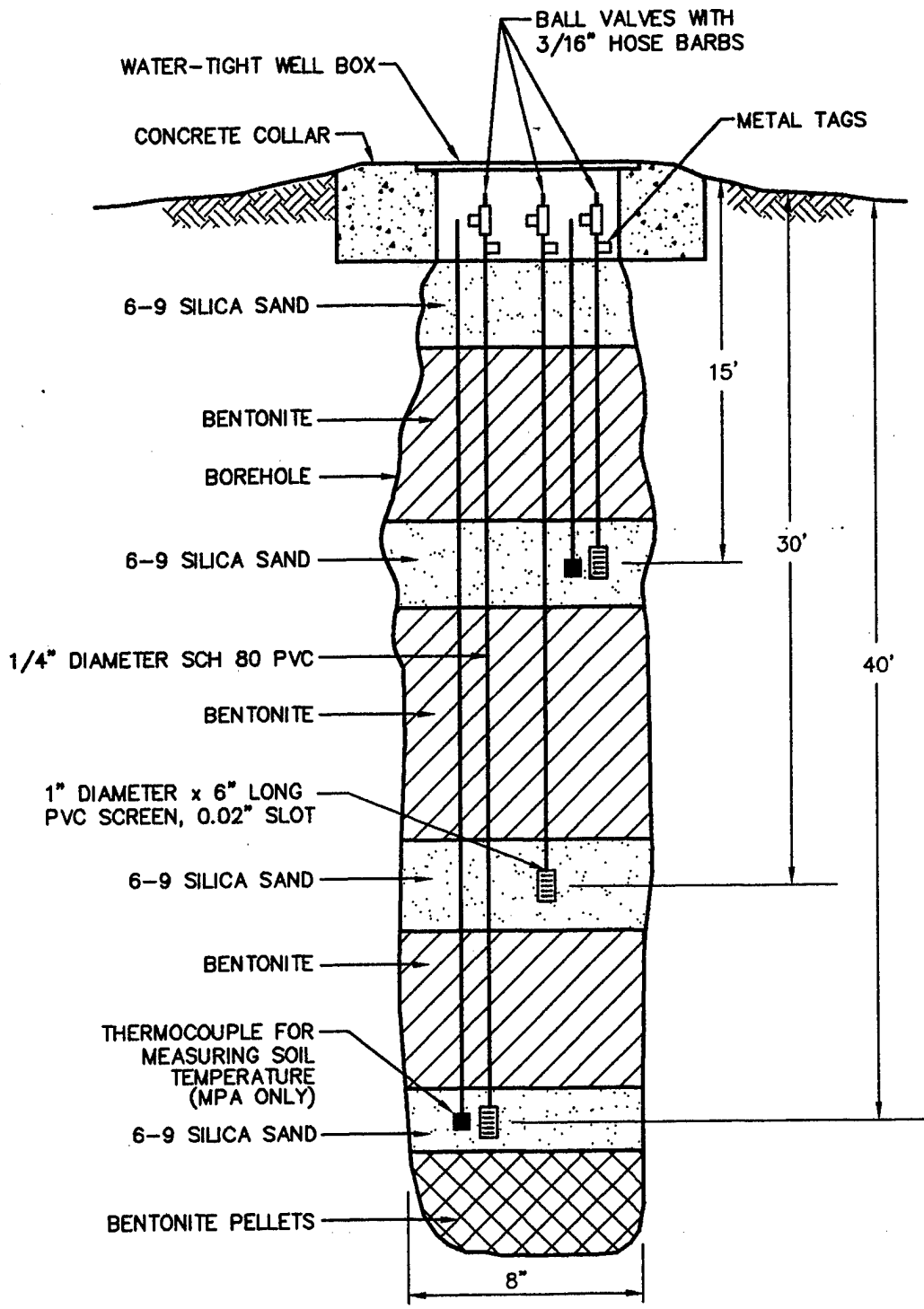

FIGURE 3.2
PROPOSED INJECTION VENT WELL
CONSTRUCTION DETAIL

SWMU 14
 Fort Rucker, Alabama

PARSONS
ENGINEERING SCIENCE, INC.

Denver, Colorado



NOT TO SCALE

FIGURE 3.3
PROPOSED MONITORING POINT
CONSTRUCTION DETAIL

 SWMU 14
 Fort Rucker, Alabama

PARSONS
ENGINEERING SCIENCE, INC.
 Denver, Colorado

Samples for TRPH and BTEX analysis will be collected using a split-spoon sampler containing brass tube liners. Soil samples collected in the brass tubes for TRPH, BTEX, and physical parameter analyses will be immediately trimmed, and the ends will be sealed with aluminum foil or Teflon[®] fabric held in place by plastic caps. Soil samples will be labeled following the nomenclature specified in the protocol document, wrapped in plastic, placed in a cooler, and maintained at a temperature of approximately 4 degrees centigrade for shipment. A chain-of-custody form will be completed, and the cooler will be shipped to an AFCEE-approved laboratory for sample analysis.

3.5.2 Soil Gas Sampling

Soil gas samples will be collected from the VW and MPs for field and laboratory analyses. Soil gas from all MP screened intervals will be analyzed using direct-reading field instruments for oxygen, carbon dioxide, and total volatile hydrocarbons (TVH). Initial soil gas samples from the six most contaminated locations will be collected in 1-liter SUMMA[®] canisters in accordance with the Bioventing Field Sampling Plan (Engineering-Science, Inc., 1992) and submitted for BTEX and TVH analyses by USEPA Method TO-3, with TVH referenced to jet fuel. These soil gas samples will be used to establish baseline site conditions, to predict potential air emissions, to determine reductions in BTEX and TVH concentrations during the 1-year pilot test, and to detect any migration of these vapors from the source area.

Soil gas sample canisters will be placed in a small cooler and packed with foam pellets to prevent excessive movement during shipment. Samples will be sent at ambient temperature to prevent condensation of hydrocarbons. A chain-of-custody form will be completed, and the samples will be shipped to the Air Toxics, Inc. laboratory in Folsom, California for analysis.

3.6 Handling of Investigation-Derived Waste

Drill cuttings will be spread on the ground surface adjacent to each boring. Augers and soil sampling equipment will be decontaminated on site, and the decontamination water will be allowed to soak into the soils covering the closed pit.

3.7 Blower System

A 2-horsepower, positive-displacement blower capable of injecting air over a wide range of flow rates and pressures will be used to conduct the initial air permeability test and *in situ* respiration test. Figure 3.4 is a schematic of a typical air injection system used for bioventing pilot testing. The maximum power requirement anticipated for this pilot test is 230-volt, single-phase, 30-amp service. Based on a site visit conducted in February 1996, electrical power will be supplied by Fort Rucker by extending an electrical line to the pilot test area from the existing power lines located along Faulkner road. Fort Rucker electricians will supply and install a new power pole at the site (Figure 3.1), an electrical distribution panel, and electrical outlets. Parsons ES will supply the blower and a motor starter, and Fort Rucker electricians will install the starter on the new power pole and complete electrical connections to the blower motor.

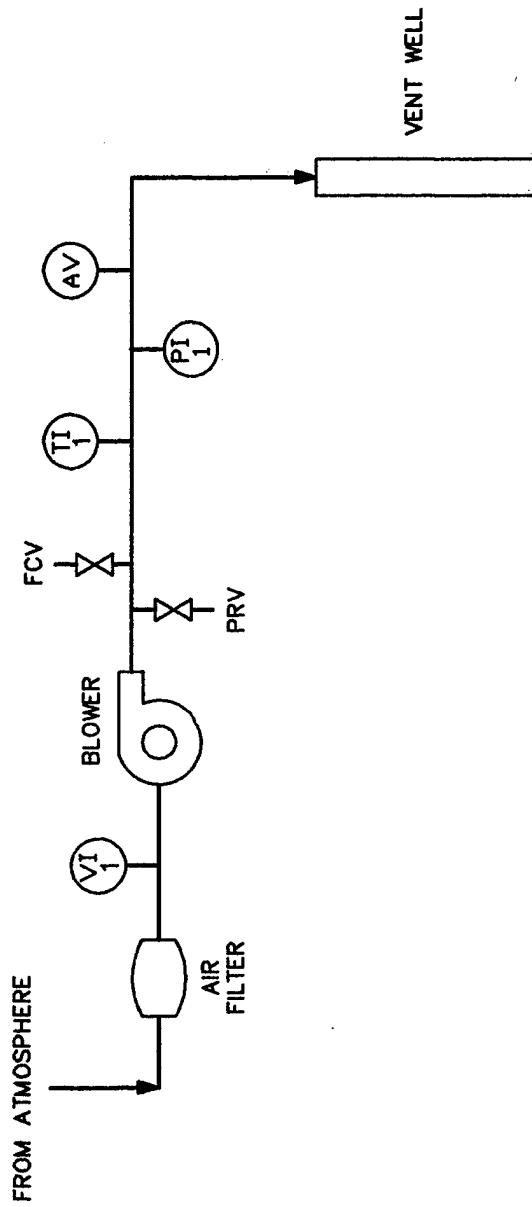

LEGEND

- VI 1 VACUUM INDICATOR
- PI 1 PRESSURE INDICATOR
- TI 1 TEMPERATURE INDICATOR
- AV AIR VELOCITY PORT
- FCV FLOW CONTROL VALVE
- PRV PRESSURE RELIEF VALVE

FIGURE 3.4

**PROPOSED BLOWER SYSTEM
INSTRUMENTATION DIAGRAM
FOR AIR INJECTION**

SWMU 14
Fort Rucker, Alabama

**PARSONS
ENGINEERING SCIENCE, INC.**

Denver, Colorado

3.8 *In Situ* Respiration Test

The objective of the *in situ* respiration test is to determine the rate at which soil bacteria degrade petroleum hydrocarbons. Respiration tests will be performed at selected MPs where bacterial biodegradation of hydrocarbons is indicated by low oxygen levels and elevated carbon dioxide concentrations in the soil gas. Using 1-cubic-foot-per-minute (cfm) pumps, air will be injected into approximately four MP depth intervals containing low levels (<2%) of oxygen. A 20-hour air injection period will be used to oxygenate contaminated soils in the vicinity of the MP intervals. At the end of the 20-hour air injection period, the air supply will be cut off, and oxygen, carbon dioxide, and TVH concentrations will be monitored for the following 48 to 72 hours. The decline in oxygen and increase in carbon dioxide concentrations over time will be used to estimate rates of bacterial degradation of fuel residuals. Helium also will be injected into the selected MP screened intervals to determine the effectiveness of the bentonite seals. Additional details on the *in situ* respiration test are found in Section 5.7 of the protocol document (Hinchee *et al.*, 1992).

3.9 Air Permeability Test

The objective of the air permeability test is to determine the extent of the subsurface that can be oxygenated using one air injection VW. Prior to initiating the test, baseline concentrations of oxygen, carbon dioxide, and TVH will be measured in soil gas from the VW and each MP screened interval.

Air will be injected into the VW using the blower unit, and pressure response will be measured at each MP with differential pressure gauges to determine the region influenced by the unit. Oxygen also will be monitored in the MPs to ascertain whether oxygen levels in the soil increase as the result of air injection. One air permeability test lasting 4 to 24 hours will be performed.

3.10 Installation of Extended Pilot Test Bioventing System

An extended, 1-year bioventing system will be installed at SWMU 14 following completion of initial testing. The system will be chosen based upon the results of the initial respiration and permeability tests. However, it is anticipated that the extended test blower will have flow rates in the range of 30 to 45 cfm and will not exceed 2.5 horsepower. The blower will be housed in a small, lockable, prefabricated shed to provide protection from the weather. The blower unit will be explosion-proof, and electrical wiring will be installed in accordance with the National Electric Code (NEC) and Fort Rucker codes for locations with potentially explosive atmospheres.

The system will be in operation for 1 year. System checks will be performed by Fort Rucker personnel every 2 weeks. If required, major maintenance of the blower unit will be performed by Parsons ES personnel. Detailed blower system information and a maintenance schedule will be included in the operation and maintenance (O&M) instructions provided to Fort Rucker. After the system has operated for 1 year, Parsons ES personnel will return to the site to conduct *in situ* respiration testing and soil gas sampling to determine the long-term effectiveness of the system.

4.0 EXCEPTIONS TO PROTOCOL PROCEDURES

The procedures that will be used to measure the air permeability of the soil and *in situ* respiration rates are described in Sections 4 and 5, respectively, of the protocol document (Hinchee *et al.*, 1992). Exceptions to the protocol are as follow:

- Six rather than the typical three soil and soil gas samples will be collected during system installation and analyzed for BTEX and TPH;
- A 1-year respiration test will be performed instead of a 6-month respiration test to evaluate system performance and remediation progress; and
- No soil samples will be collected after the 1-year period of system operation as part of this 1-year pilot test. Based on 1-year respiration testing and soil gas sampling results, a recommendation will be made to 1) continue system operation if testing indicates that significant contaminants remain in the soil; or 2) perform closure soil sampling if results indicate that the site has been sufficiently remediated.

5.0 FACILITY SUPPORT REQUIREMENTS

5.1 Test Preparation Support

The following Fort Rucker support is needed prior to the arrival of the drilling subcontractor and the Parsons ES pilot test team:

- Assistance in obtaining drilling and digging permits;
- Provision of any paperwork required to obtain gate passes and security badges (if necessary) for approximately two Parsons ES employees, three drillers, and any regulatory personnel visiting the site. Vehicle passes will be needed for one Parsons ES truck and trailer, and a drill rig and supply truck;
- Installation of electrical power to the site from the existing electrical lines located along Faulkner Road; and
- Removal of pine trees from the site in the vicinity of the VW, MPs, and MW 14-G8 in preparation for drilling activities.

5.2 Initial Testing Support

During the initial testing, the following Fort Rucker support is needed:

- A potable water supply for VW and MP construction and decontamination activities; and
- Motor starter installation and completion of electrical connections for the blower motor (Parsons ES will supply the starter and blower).

5.3 Extended Testing Support

During the 1-year extended pilot test, Fort Rucker personnel will be required to perform the following activities:

- Check the blower system every other week to ensure that it is operating properly and record the air injection pressure and other parameters. Parsons ES will provide a brief training session for personnel from Fort Rucker Environmental and Natural Resources Division on this procedure.
- If the blower stops working, notify Mr. John Hall (Parsons ES-Grand Junction, CO) at (970) 244-8829, Mr. John Ratz (Parsons ES-Denver, CO) at (303) 831-8100, Mr. Troy Marcella (Parsons ES-Baton Rouge, LA) at (504) 293-6680, Mr. Gene Fabian (USAEC) at (410) 612-6847, or Mr. James Gonzales of AFCEE at (210) 536-4324.
- Arrange site access for a Parsons ES technician to conduct an *in situ* respiration test and soil gas sampling approximately 1 year after the initial pilot test.

6.0 PROJECT SCHEDULE

The following schedule is contingent upon approval of this pilot test work plan and completion of facility support requirements.

<u>Event</u>	<u>Date</u>
Draft Test Work Plan to AFCEE/USAEC/Fort Rucker	18 March 1996
Receive Work Plan Review Comments	19 April 1996
Deliver Final Test Work Plan to AFCEE/USAEC/ Fort Rucker (if required)	1 May 1996
Begin Initial Pilot Test	13 May 1996
Interim Results Report	12 July 1996
Final Respiration Test/Soil Gas Sampling	June 1997
Final Results Report	August 1997

7.0 POINTS OF CONTACT

Mr. Gene Fabian
Building E4430
SFIM-AEC-ETD
Aberdeen Proving Ground, MD 21010-5401
DSN 584-6847
COM (410) 612-6847
FAX (410) 612-6836

Mr. Jim Swift
Environmental Coordinator
ATZQ-DPW-EN
Building 1453
Fort Rucker, AL 36362
(334) 255-9588
FAX (334) 255-2058

Capt Ed Marchand/Mr. Marty Faile/Mr. James Gonzales
AFCEE/ERT
8001 Arnold Drive
Brooks AFB, TX 78235-5357
Capt Marchand: (210) 536-4364
Mr. Faile: (210) 536-4342
Mr. Gonzales: (210) 536-4324
FAX: (210) 536-4330

Mr. John Ratz
Parsons Engineering Science, Inc.
1700 Broadway, Suite 900
Denver, CO 80290
(303) 831-8100
FAX (303) 831-8208

Mr. John Hall
Parsons Engineering Science, Inc.
257 A 28 Road
Grand Junction, CO 81503
(970) 244-8829
FAX (970) 244-8829

8.0 REFERENCES

- Army Environmental Hygiene Agency. 1986.
- Engineering-Science, Inc. 1992. *Field Sampling Plan for AFCEE Bioventing*. Denver, Colorado. January.
- Hinchee, R.E., S.K. Ong, R.N. Miller, D.C. Downey, and R. Frendt. 1992. *Test Plan and Technical Protocol for a Field Treatability Test for Bioventing*. Denver, Colorado. May.
- Leeson, A., R.E. Hinchee, B.A. Alleman, D.C. Downey, G. Headington, J.A. Kittel, P. Kumar, R.N. Miller, S.K. Ong, G.D. Sayles, L. Smith, and C.M. Vogel. 1995. *Principles and Practices of Bioventing, Volumes I and II*. Columbus, Ohio. September 29.
- Metcalf & Eddy, Inc. 1995. *Fort Rucker Phase II RCRA Facility Investigation, Final Report, Volume II, Sites for Corrective Measures Study*. November.
- US Army Corps of Engineers. 1983. *Reservation Map, Fort Rucker, Alabama, Drawing No. 18-05-01*. Mobile, Alabama. July.