

LOAN DOCUMENT

DTIC ACCESSION NUMBER	PHOTOGRAPH THIS SHEET	INVENTORY
	LEVEL	①
2 Parts		
Bioventing Test Work Plan for IRP Site...		
DOCUMENT IDENTIFICATION		
Sep 94		
DISTRIBUTION STATEMENT A Approved for Public Release Distribution Unlimited		
DISTRIBUTION STATEMENT		
NTIS GRAM DTIC TRAC UNANNOUNCED JUSTIFICATION		DATE ACCESSIONED
BY		
DISTRIBUTION/		DATE RETURNED
AVAILABILITY CODES		
DISTRIBUTION	AVAILABILITY AND/OR SPECIAL	REGISTERED OR CERTIFIED NUMBER
A-1		
DISTRIBUTION STAMP		
DTIC QUALITY INSPECTED 4		
20001208 112		
DATE RECEIVED IN DTIC		
PHOTOGRAPH THIS SHEET AND RETURN TO DTIC-FDAC		

H
A
N
D
L
E

W
I
T
H

C
A
R
E

PART I

**BIOVENTING TEST WORK PLAN FOR
IRP SITE ST-08
FORMER FUEL OIL STORAGE FACILITY
POPE AFB, NORTH CAROLINA**

PART II

**DRAFT INTERIM BIOVENTING PILOT
TEST RESULTS REPORT
IRP SITE ST-08
FORMER FUEL OIL STORAGE FACILITY
POPE AFB, NORTH CAROLINA**

Prepared for

**Air Force Center For Environmental Excellence
Brooks AFB, Texas**

and

**23rd CES/CEV
Pope AFB, North Carolina**



DEFENSE TECHNICAL INFORMATION CENTER REQUEST FOR SCIENTIFIC AND TECHNICAL REPORTS

Title AFCEE Collection

1. Report Availability (Please check one box)

- This report is available. Complete sections 2a - 2f.
- This report is not available. Complete section 3.

2a. Number of Copies Forwarded

Each

2b. Forwarding Date

July/2000

2c. Distribution Statement (Please check ONE box)

DoD Directive 5230.24, "Distribution Statements on Technical Documents," 18 Mar 87, contains seven distribution statements, as described briefly below. Technical documents MUST be assigned a distribution statement.

- DISTRIBUTION STATEMENT A: Approved for public release. Distribution is unlimited.
- DISTRIBUTION STATEMENT B: Distribution authorized to U.S. Government Agencies only.
- DISTRIBUTION STATEMENT C: Distribution authorized to U.S. Government Agencies and their contractors.
- DISTRIBUTION STATEMENT D: Distribution authorized to U.S. Department of Defense (DoD) and U.S DoD contractors only.
- DISTRIBUTION STATEMENT E: Distribution authorized to U.S. Department of Defense (DoD) components only.
- DISTRIBUTION STATEMENT F: Further dissemination only as directed by the controlling DoD office indicated below or by higher authority.
- DISTRIBUTION STATEMENT X: Distribution authorized to U.S. Government agencies and private individuals or enterprises eligible to obtain export-controlled technical data in accordance with DoD Directive 5230.25, Withholding of Unclassified Technical Data from Public Disclosure, 6 Nov 84.

2d. Reason For the Above Distribution Statement (in accordance with DoD Directive 5230.24)

2e. Controlling Office

HQ AFCEE

2f. Date of Distribution Statement Determination

15 Nov 2000

3. This report is NOT forwarded for the following reasons. (Please check appropriate box)

- It was previously forwarded to DTIC on _____ (date) and the AD number is _____
- It will be published at a later date. Enter approximate date if known. _____
- In accordance with the provisions of DoD Directive 3200.12, the requested document is not supplied because:

Print or Type Name

Laura Peña

Signature

Laura Peña

Telephone

210-536-1431

(For DTIC Use Only)

AQ Number M01-03-0427

PART I

**BIOVENTING TEST WORK PLAN FOR
IRP SITE ST-08
FORMER FUEL OIL STORAGE FACILITY
POPE AFB, NORTH CAROLINA**

PART II

**DRAFT INTERIM BIOVENTING PILOT
TEST RESULTS REPORT
IRP SITE ST-08
FORMER FUEL OIL STORAGE FACILITY
POPE AFB, NORTH CAROLINA**

Prepared for

**Air Force Center For Environmental Excellence
Brooks AFB, Texas**

and

**23rd CES/CEV
Pope AFB, North Carolina**

PART I

**BIOVENTING TEST WORK PLAN FOR
IRP SITE ST-08
FORMER FUEL OIL STORAGE FACILITY
POPE AFB, NORTH CAROLINA**

Prepared for:

**AIR FORCE CENTER FOR ENVIRONMENTAL EXCELLENCE
BROOKS AFB, TEXAS**

and

**23RD CES/CEV
POPE AFB, NORTH CAROLINA**

September 1994

Prepared by:

Engineering-Science, Inc.
401 Harrison Oaks Blvd., Suite 210
Cary, North Carolina

CONTENTS

	<u>Page</u>
1.0 Introduction	I-1
2.0 Site ST-08 Description.....	I-1
2.1 Site Location and History	I-1
2.2 Previous Investigations.....	I-2
2.3 Regional and Site Geology	I-5
2.3.1 Regional Geology and Hydrogeology	I-5
2.3.2 Site Geology and Hydrogeology	I-6
2.4 Site Contaminants.....	I-7
3.0 Site Specific Activities.....	I-7
3.1 Bioventing Test Design for Site ST-08	I-7
3.1.1 Air Injection Vent Well Construction	I-9
3.1.2 Vapor Monitoring Point Construction	I-12
3.2 Handling of Soil Boring Cuttings	I-12
3.3 Soil and Soil Gas Sampling	I-12
3.3.1 Soil Sampling	I-12
3.3.2 Soil Gas Sampling	I-13
3.4 Blower System	I-13
4.0 Exceptions to Protocol Procedures.....	I-13
5.0 Base Support Requirements	I-15
5.1 Test Preparation.....	I-15
5.2 Permit Requirements	I-16
6.0 Project Schedule	I-16
7.0 Points of Contact	I-17
8.0 References	I-17

FIGURES

<u>No.</u>	<u>Title</u>	<u>Page</u>
2.1	Pope AFB Location Map	I-3
2.2	Site Plan	I-4
3.1	Proposed Vent Well/Monitoring Point Locations	I-8
3.2	Proposed Air Injection Vent Well Construction	I-10
3.3	Typical Monitoring Point Construction Detail	I-11
3.4	Blower System Instrumentation Diagram For Air Injection.....	I-14

**BIOVENTING TEST WORK PLAN FOR
IRP SITE ST-08
FORMER FUEL OIL STORAGE FACILITY
POPE AFB, NORTH CAROLINA**

1.0 INTRODUCTION

This site-specific work plan presents the scope of a bioventing pilot test for *in-situ* treatment of fuel-contaminated soils at Installation Restoration Program (IRP) Site ST-08 Former Fuel Oil Storage Facility located at Pope Air Force Base, North Carolina. The site is a former #2 fuel oil storage and distribution facility located between Taxiway B and Boxcar Street on the base. The proposed pilot test has three primary objectives: 1) to assess the potential for supplying oxygen throughout the contaminated soil depth, 2) to determine the rate at which indigenous microorganisms will degrade the fuel when stimulated by oxygen-rich soil gas, and 3) to evaluate the potential for sustaining these rates of biodegradation until fuel contamination is remediated below regulatory standards. If bioventing proves to be a feasible technology for this site, pilot test data can be used to design a full-scale remediation system and to estimate the time required for remediating soils to regulatory standards. An added benefit expected during pilot testing at this site is that a significant amount of the fuel contamination should be biodegraded during the one-year pilot test.

The pilot test system will involve two vertical air injection wells and a blower capable of sustaining a flow rate of at least 30 standard cubic feet per minute (scfm). Each vent well (VW) is expected to achieve an oxygen radius of influence of approximately 25 to 35 feet (ft), based on the moderately high water table at the site. The design flow rate and actual radius of influence for any one site will depend on soil properties, unsaturated soil thickness, and other factors. Rates of *in-situ* fuel biodegradation can also vary considerably and will be determined for individual soil vapor monitoring points (VMPs) that will be installed around the vent wells.

Additional background information on the development and recent success of the bioventing technology is found in the document entitled *Test Plan and Technical Protocol For A Field Treatability Test For Bioventing*. The protocol document is a supplement to this site-specific work plan and it will also serve as the primary reference for pilot test well designs and detailed test objectives and procedures. Unless otherwise noted, test procedures outlined in the protocol document will be used during the pilot test at Site ST-08 Former Fuel Oil Storage Facility.

2.0 SITE ST-08 DESCRIPTION

2.1 Site Location and History

Pope AFB is located on 1,869 acres within the Fort Bragg Military Reservation, northwest of Fayetteville, North Carolina in the south-central part of the state. Site ST-08 Former Fuel Oil Storage Facility is located near the center of the base, between Taxiway B and Boxcar Street and adjacent to Tank Creek. Pope AFB has designated

several petroleum tank sites around the base as inclusive of Site ST-08, including the former fuel oil storage facility. Therefore, any references to "Site ST-08" within this work plan are intended to mean exclusively the former fuel oil storage facility located between Taxiway B and Boxcar Street. Figure 2.1 shows the location of Pope AFB and the test site on a U.S.G.S topographic map.

This site was previously utilized as a #2 fuel oil (heating oil) storage and distribution facility for the base. Fuel oil was delivered to the site in tanker trucks and by rail cars, where it was unloaded and stored in four 25,000-gallon steel underground storage tanks (USTs). Fuel delivery trucks were then used to distribute the #2 fuel oil to smaller fuel storage tanks at buildings throughout the base, where it was used for heating purposes. The base reports that the four USTs were installed in the early-to mid-1970's.

The four USTs, ancillary piping, and fuel dispensers were excavated and removed from the site in November 1992 after the UST system failed integrity testing. Contaminated soil was encountered during the UST system removal and the base reports that floating fuel (free product) was observed on water that collected in the open excavation. The base reports that fuel-contaminated soil excavated during the UST system removal was placed back into the excavation after the USTs were removed. It was also reported that the UST removal contractor placed a layer of thick plastic in the hole at a depth of about 15 feet prior to backfilling. Figure 2.2 shows a site plan of Site ST-08 with the former UST system location.

2.2 Previous Investigations

The Army Corps of Engineers (COE) performed a soil gas survey at the site in May 1994 to estimate the extent of the fuel contamination and to investigate the suspected presence of oily-phase product. The soil gas investigation was conducted primarily northwest, north, and northeast of the former USTs since it was suspected that fuel contamination was migrating on the water table toward Tank Creek (see Figure 2.2). Fifty shallow temporary soil gas probes were installed to depths just above the water table surface and soil gas samples were collected and analyzed with a portable field gas chromatograph (GC). The soil gas samples were analyzed for benzene, toluene, ethylbenzene, and xylenes (BTEX), and the hydrocarbons n-pentane, n-hexane, n-heptane, n-octane, n-nonane, and n-decane. Approximately seventeen of the fifty samples had detections of one or more of these compounds; however, the total BTEX concentrations were generally less than 10 parts per million by volume (ppmv) for most of the samples. Low concentrations of BTEX and other volatile organic compounds (VOCs) are typical for heavier fuels such as #2 fuel oil.

In August 1994, ES conducted a preliminary soil gas/soil boring survey at the Site ST-08 Former Fuel Oil Storage Facility as part of a base-wide search for candidate bioventing study sites. Four exploratory soil gas points and three shallow, hand-augered soil borings were installed within the former UST system and excavation area. The temporary soil borings and soil gas samples were used to determine soil gas composition, to identify fuel-contaminated soils, and to provide lithologic characteristics. The hand-augered soil borings were installed to the water table to estimate the depth to groundwater since there are currently no groundwater monitoring wells at the site. A total hydrocarbon analyzer was used to monitor the soil gas

Figure 2.1

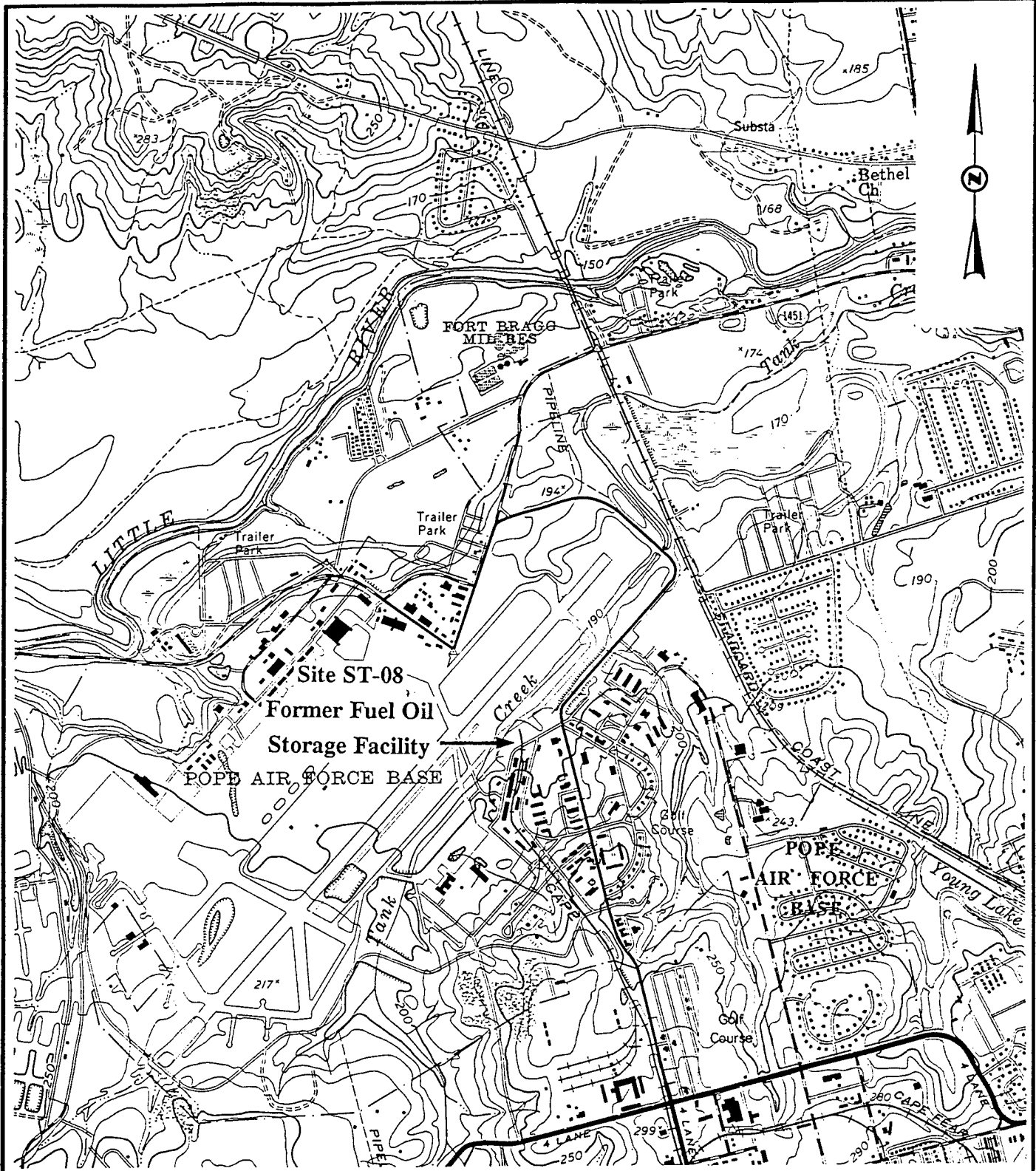

72240722.dwg / ps:1=1 / 9-12-94 / TLP

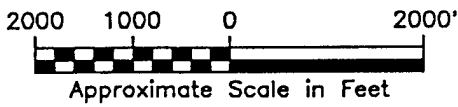

From: U.S.G.S. Overhills & Manchester, NC Quadrangles (7.5 Minute Topographic Map - 1971 & 1987)

Pope Air Force Base Location Map

IRP Site ST-08
Pope AFB
Fayetteville, North Carolina

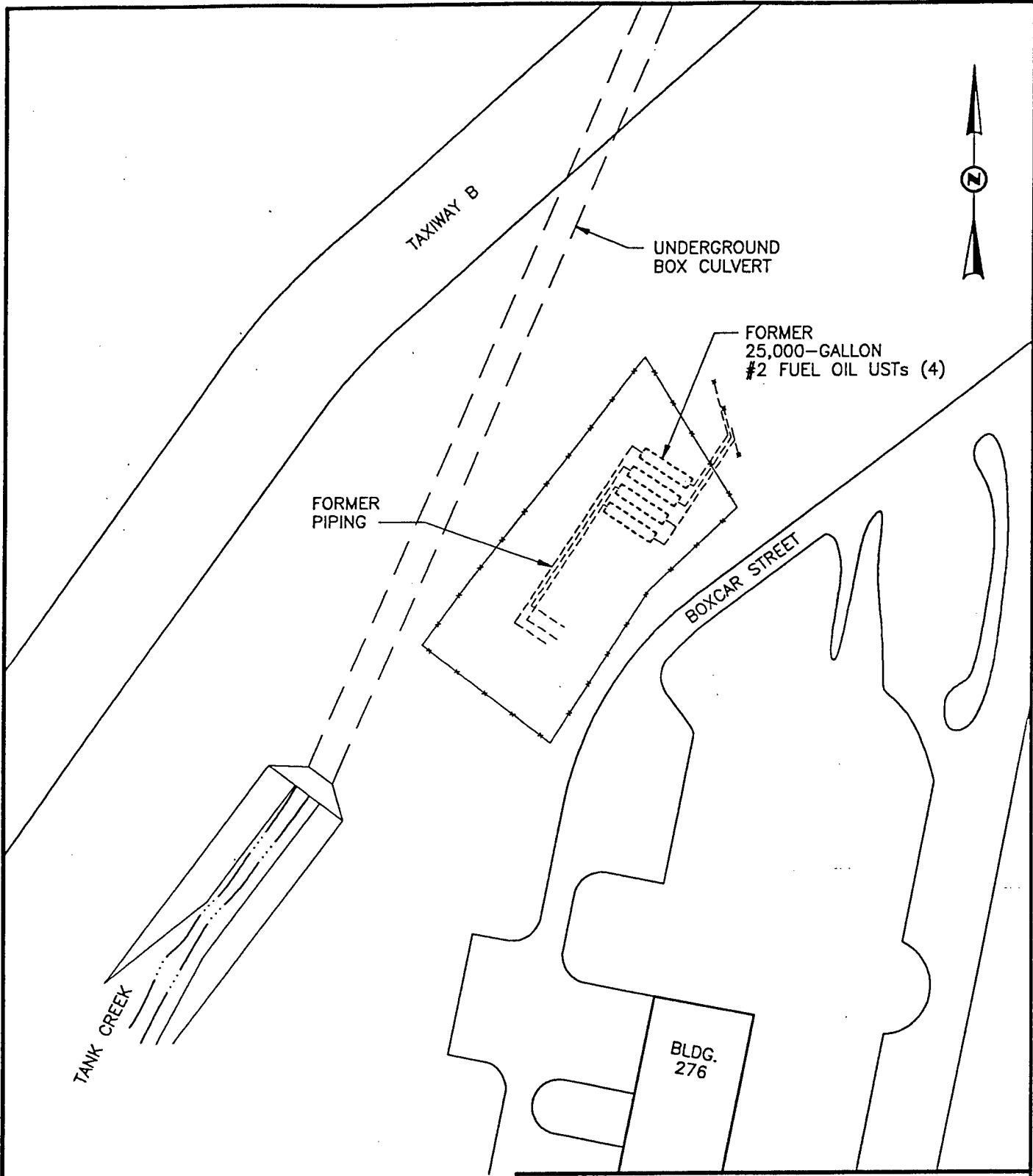

Note:

1. The USTs, ancillary piping, and fence were removed in November 1992.

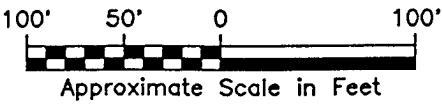

Site Plan
IRP Site ST-08 Pope AFB Fayetteville, North Carolina

72240726.dwg / ps:1=1 / 9-21-94 / TLP

samples and the headspace of the soil boring samples as an indicator of relative fuel contamination.

Engineering-Science, Inc. utilized a soil gas probe with a retractable tip during the limited soil gas survey. Four temporary soil gas probes were installed within the former UST excavation area to monitor total volatile hydrocarbon (TVH), oxygen (O₂), and carbon dioxide (CO₂) concentrations within the soil gas. TVH concentrations ranged from 980 ppmv to greater than 10,000 ppmv at depths ranging from 2 to 8 feet below ground surface (bgs). Depleted O₂ and increased CO₂ levels within contaminated soil gas is an indicator of aerobic biodegradation in the soils. Oxygen concentrations were depressed in shallow soils (<5 feet bgs), ranging from 11 to 16 percent. Soil gas oxygen concentrations in deeper soils (5 to 8 feet bgs) ranged from 0 to 2.5 percent. Carbon dioxide concentrations ranged from 5.5 to 12.5 percent and were generally higher in the deeper, more contaminated soil gas sampling points.

The design of this test work plan is based solely on limited site data collected by ES and the COE to date. Preliminary site screening data suggest that the Site ST-08 former fuel oil storage facility is a good candidate for bioventing, since a widespread area of fuel-contaminated, oxygen-deficient soils has been identified. The existing data are considered sufficient for designing the bioventing pilot study. ES may perform additional soil gas sampling prior to well installation to optimize the vent well and vapor monitoring point placements. Additionally, ES understands that the COE plans to install at least two groundwater monitoring wells at the site in late September 1994. ES will gauge these wells to confirm the depth to water at the site prior to installing the VWs and VMPs. The groundwater monitoring wells may also be used during bioventing pilot testing to measure soil pressures and soil gas composition. Additional sampling results and site investigation data will be evaluated by ES prior to installing the bioventing system to determine their potential impact on the pilot test objectives, design, or procedures.

2.3 Regional and Site Geology

2.3.1 Regional Geology and Hydrogeology

Pope AFB is located within the inner Coastal Plain physiographic province of North Carolina. The base is located in a subprovince of the inner Coastal Plain known as the Sandhills region. As the name implies, the Sandhills region is characterized by rounded hills composed of loose to fairly poorly consolidated Cretaceous-age sands (Schopf, 1961). Swampy flood plains and dendritic drainage patterns are typical of this area. Sediments beneath the base are characterized as a thick sequence of interbedded sands, silts, and clays that were formed by fluvial and marine processes. Surficial soils beneath the upland areas in this region are characterized as sandy and highly permeable. Interbedded layers may contain zones of clay and organic deposits. The Sandhills region is marked by moderate to steep geomorphic relief compared to other areas of the Coastal Plain province (USGS, 1989).

The stratigraphy beneath Pope AFB consists of sands, silts, and clays of the Middendorf and Cape Fear Formations. Quaternary-age alluvium consisting of sand, gravel, silt, and clay locally overlies these formations around stream valleys. The Middendorf Formation is characterized as unconsolidated to semi-consolidated fine to coarse sands, with interbedded lenses of clay and silt, that are brownish-gray to pale

gray in color. Portions of these sediments may be mottled with an orange cast. Clay balls and iron-cemented concretions are common within this formation. The Cape Fear Formation, which underlies the Middendorf Formation, was encountered at depths of 4 to 33 feet bgs during previous investigations at Pope AFB (Metcalf & Eddy, 1993). The Cape Fear Formation is described as discontinuous layers of pale gray to gray, micaceous, silty sand, sandy silt, clayey silt, and silty clay that are densely-packed stiff, and slightly to moderately plastic. The thickness of the coastal plain sediments average about 90 feet in the vicinity of the base. These sediments unconformably overlie metamorphosed crystalline and volcanoclastic rocks of the Carolina Slate Belt in this region.

Sediments of the Coastal Plain physiographic province are grouped into regional aquifers based on lithologic, hydraulic, and water quality characteristics. Groundwater beneath Pope AFB occurs within two principal aquifer systems. The Cretaceous aquifer system includes water-bearing zones of the Middendorf and Cape Fear Formations. The water table aquifer can occur in either of these formations, or within the veneer of Quaternary alluvial sediments (where present), based on topographic elevation and proximity to streams. The second aquifer system is the underlying crystalline bedrock unit. Groundwater occurs in fractures in this unit; however water-supply wells supplied by the fractured rock aquifer typically have lower yields than wells that tap the sands of the Cretaceous aquifer system.

2.3.2 Site Geology and Hydrogeology

A soil boring and well installation program has not been conducted at the Site ST-08 former fuel oil storage facility to date; therefore, the local lithology of the site is not extensively characterized. ES advanced three hand-augered borings during a limited soil boring survey to provide preliminary characterization of site lithology and to determine depth to groundwater. Soil samples described from the borings show that the upper 8 feet is generally silty to clayey sands and sandy clay, mixed with backfill material in the former UST excavation. A permeable, fine sand layer with strong fuel odors was encountered between 8 and 10.5 feet bgs and a layer of gray clay was encountered at 10.5 to 12 feet bgs in two borings.

During ES's preliminary screening of the site, water-saturated soils were detected at approximately 13 feet bgs in the soil borings. Pope AFB personnel reported that water was seeping into the open excavation at estimated depths of 12 to 14 feet bgs during the UST removals. Based on these observations, ES estimates that the water table is approximately 13 to 14 feet bgs near the center of this site. The water table is typically highest in this region during the winter months and seasonal water table fluctuations of several feet are common. Because the bioventing technology is applied to unsaturated soils, the thickness of the soil treatment zone is expected to vary on a seasonal basis due to water table fluctuations. As a result, the lower one or two feet of the VW screens may become submerged during periods of exceptionally high water levels.

Because there are currently no groundwater monitoring wells at Site ST-08, the groundwater flow direction and hydraulic gradients have not been determined. However, local topography and the proximity to Tank Creek suggest that shallow groundwater probably flows toward the north, northwest, and west where it discharges to Tank Creek. A base water table potentiometric map constructed from water level

data at nearby IRP sites shows a regional groundwater flow direction toward the north, with local influences caused by surface water bodies including Tank Creek (Metcalf & Eddy, 1993).

2.4 Site Contaminants

The suspected contaminants at Site ST-08 Former Fuel Oil Storage Facility are petroleum hydrocarbons derived from #2 fuel oil (heating oil). Fuel odors and organic hydrocarbon vapors were detected in the soils at depths up to 13 feet bgs. Direct readings of soil gas TVH ranged from 980 to >10,000 ppmv. Soil sample headspace TVH readings (from soil borings) ranged from 40 to 1,000 ppmv. BTEX compounds are a minor constituent of low-boiling-point distillates such as fuel oils and are not expected at this site in elevated concentrations. Some minor concentrations of BTEX were detected in soil gas during the COE soil gas survey. The presence (or absence) of groundwater contamination and oily-phase product will be confirmed in late September or early October 1994 when the COE installs two groundwater monitoring wells at the site.

The only suspected source of the soil contamination is the former fuel oil USTs. Although a significant quantity of contaminated soil was excavated and removed from the site, preliminary site screening indicates that fuel-contaminated soils remain in the area of the former USTs. If oily-phase product is in contact with groundwater, water table fluctuations have likely created a contaminant "smear zone" within vadose zone soils at the site. Decreased oxygen concentrations and increased TVH readings with depth suggest that soils with the greatest concentrations of fuel oil contamination are generally located greater than 5 feet bgs.

3.0 SITE SPECIFIC ACTIVITIES

This section describes the proposed location of the air injection vent wells (VWs) and vapor monitoring points (VMPs) at Site ST-08 Former Fuel Oil Storage Facility. Soil sampling procedures and the blower configuration that will be used to inject air (oxygen) into contaminated soils are also discussed in this section. Groundwater monitoring wells planned for this site will be evaluated for their potential use as VMPs during the bioventing pilot study as this project progresses.

Two 4-inch diameter vertical air injection VWs, four multi-depth VMPs, and one temporary background VMP will be installed for this bioventing pilot test. The two air injection VWs may be completed one or two feet into groundwater if the water table is elevated during well installations. Vent well design will ensure that an adequate portion of the screen remains above the water table throughout the year. The temporary background VMP will be installed in uncontaminated soils away from the site to measure for abiotic and/or non-fuel oxygen uptake.

3.1 Bioventing Test Design For Site ST-08

A general description of criteria for siting VWs and VMPs are included in the bioventing protocol document. Figure 3.1 illustrates the proposed locations of the vertical air injection VWs and VMPs at the site. The VWs and VMPs will be located in the most fuel-contaminated and oxygen-deficient soils identified at the test site. ES anticipates that the pilot test site will be located within, or adjacent to, the former UST excavation area. The final locations of these wells may vary slightly from the locations

Figure 3.1

72240727.dwg / ps:1=1 / 9-22-94 / TLP

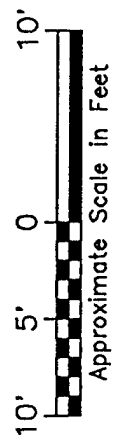
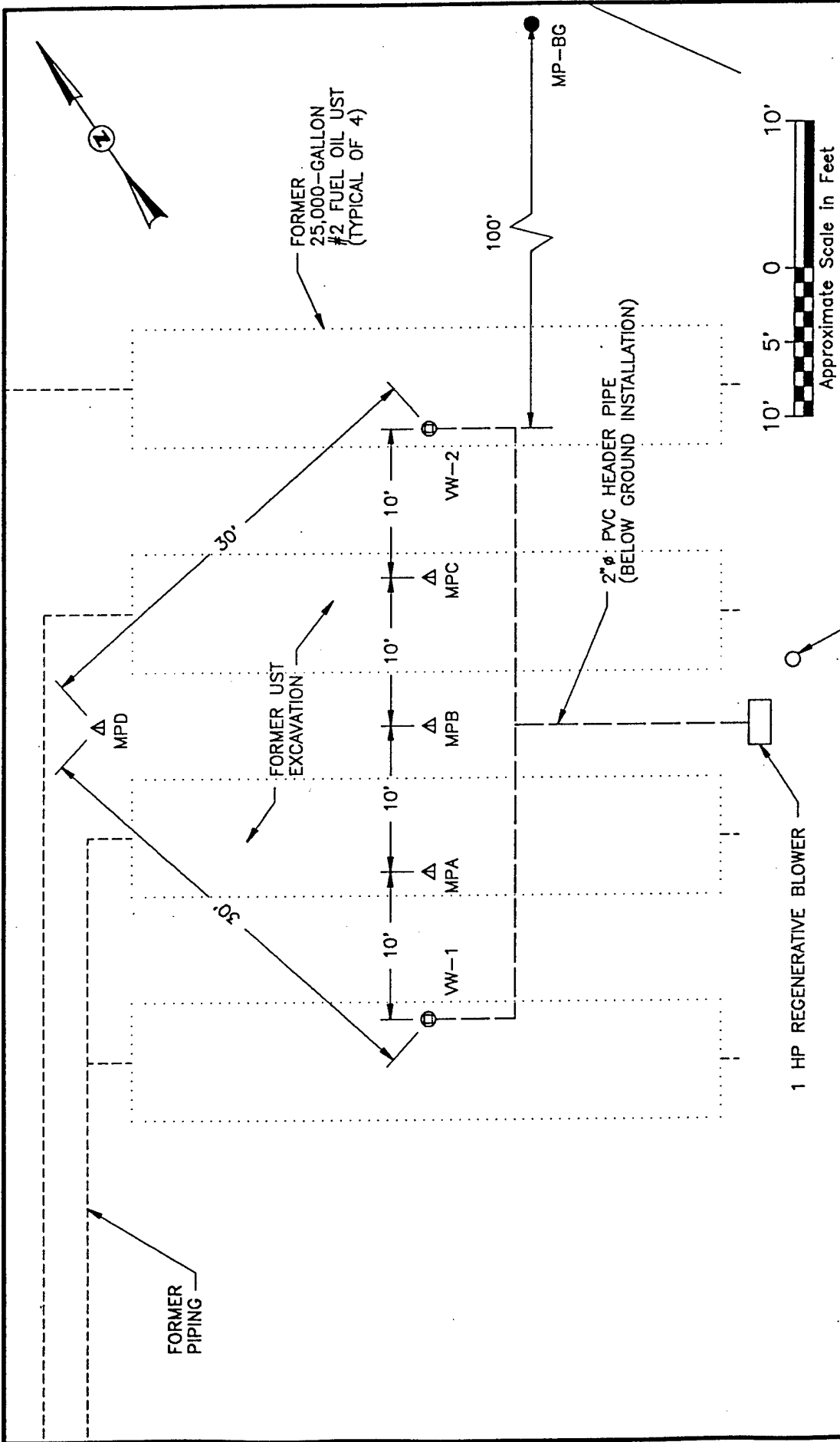

Proposed Vent Well and Monitoring Point Locations

IRP Site ST-08
Pope AFB
Fayetteville, North Carolina

LEGEND

- VW ⊕ Proposed air injection vent well.
- MPA Δ Proposed soil vapor/pressure monitoring point.
- MP-BG ● Proposed background monitoring point.

Note: Final location of bioventing system may vary from the location depicted above. The relative configuration of VWs and MPs will remain unchanged.

shown in Figure 3.1 based on site conditions encountered during the well installations. Additional soil gas screening will be performed prior to VW installations to ensure that the pilot test system is located in oxygen-depleted soils.

Considering the shallow depth of contamination in unsaturated soils at this site (< 8 feet bls), the soil lithology, and the VW construction required to accommodate shallow water table conditions, the radius of oxygen influence around a single air injection well is expected not to exceed 35 feet. Further reductions in the estimated radius of influence may be expected during high water table conditions when the unsaturated VW screen interval is decreased. The potential for short-circuiting of injected air at the ground surface is greater as the air injection pressures and/or flow rates increase and as the unsaturated soil column thickness is decreased. Short-circuiting of injected air also results in a loss of the effective radius of venting influence. For this reason, a multiple VW system (2 vent wells) will be installed at this site. The dual VW system will allow a larger cumulative radius of influence to be maintained with lower injection pressures and air flow rates at the individual VWs.

Three multi-depth VMPs will be located on 10-foot centers along the axis connecting the two VWs. The fourth VMP will be located perpendicular to this axis (see Figure 3.1). The VWs will be installed 40 feet apart so that their radii of venting influence will overlap near the center VMP. A temporary background VMP will be installed in uncontaminated soils using a soil gas probe. The temporary VMP will be utilized to measure background levels of O₂ and CO₂ and to determine if natural, non-fuel carbon sources (i.e. organic layers) or mineral reactions are contributing to oxygen uptake during the *in-situ* respiration tests. A respiration test will be conducted at the temporary VMP only if background O₂ concentrations are less than 18 percent. Additional details on the *in-situ* respiration test are found in Section 5.7 of the protocol document.

3.1.1 Air Injection Vent Well Construction

A drill rig will be used to advance the VW boreholes and to collect split spoon soil samples. The air injection VWs will be constructed of 4-inch (ID) Schedule 40 PVC, with 10 feet of 0.02-inch slotted screen per well. "High-yield" recovery well screens will be used to increase air flow rates and to decrease backpressure created at the well screen. Each VW will be installed to an approximate total depth of 15 feet, with the screened interval extending from approximately 5 feet to 15 feet bgs. A PVC casing will be installed above the screen, from approximately 0.5 feet to 5 feet bgs. Flush-threaded PVC casings and screens will be used with no organic solvents or glues.

A filter pack of coarse silica sand will be placed around each VW screen in the borehole annulus. A bentonite pellet seals and grout seals will be placed above the filter packs to seal each borehole. A complete seal is critical to prevent injected air from short-circuiting to the surface during the bioventing test. The VWs will be installed below-grade in watertight locking flush-mounted vaults. The vaults will be sealed in concrete collars to maintain structural support and to minimize possible air losses around the well casing. Figure 3.2 illustrates a typical air injection VW construction for this site.

Figure 3.2

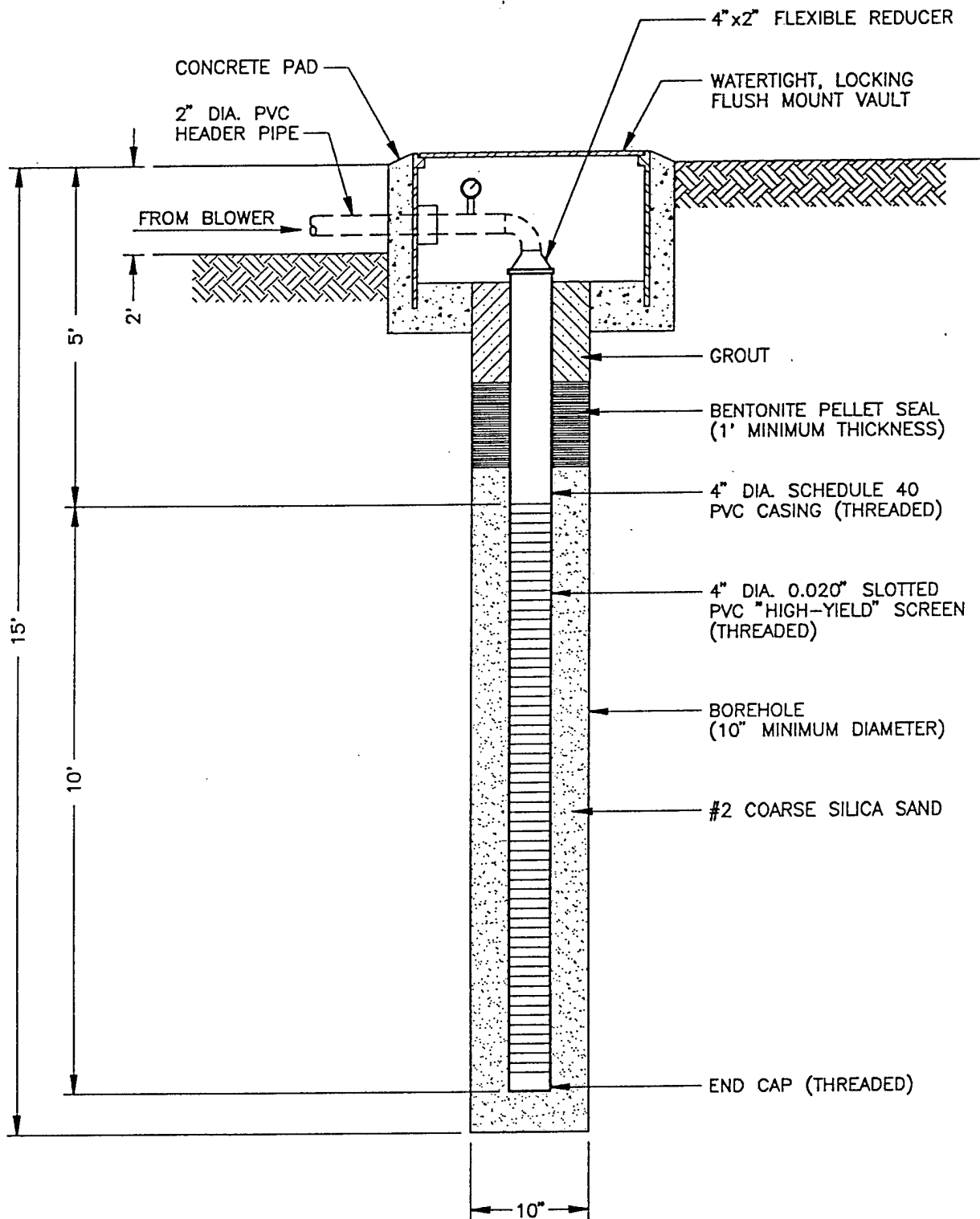

NOTES:

1. Drawing is not to scale.
2. Header pipe from blower (dashed line) will not be installed during well construction.

**Proposed Air Injection Vent
Well Construction**

IRP Site ST-08
Pope AFB
Fayetteville, North Carolina

72240723.dwg / 1=1 / 9-12-94 / TLP

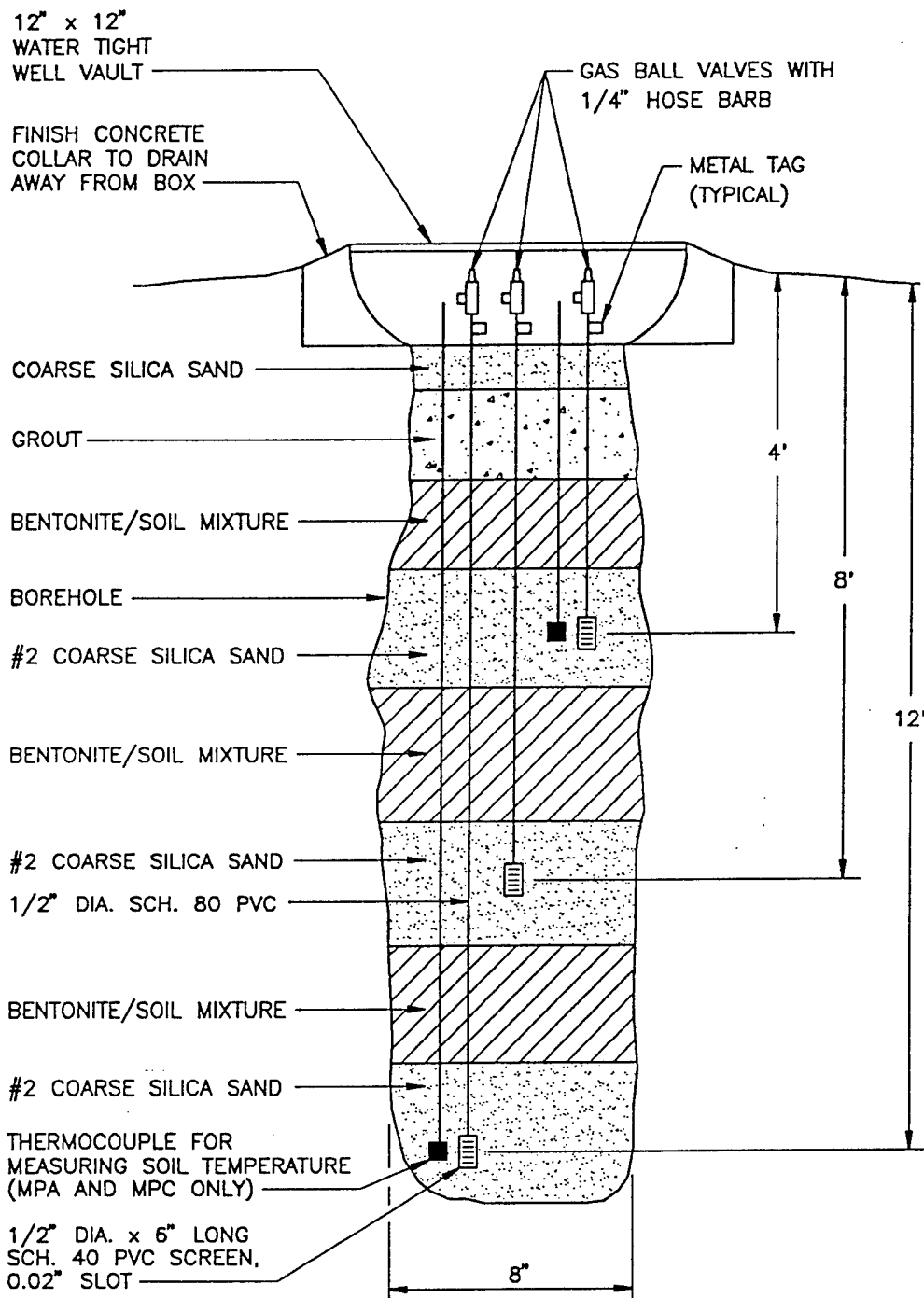

DRAWING IS NOT TO SCALE

Typical Monitoring Point
Construction Detail

IRP Site ST-08
Pope AFB
Fayetteville, North Carolina

Note:

1. Water table depth is estimated as 13 to 14 feet below ground surface at test site. The VMP construction may be modified to 2 screened intervals if the water table is significantly higher.

72240724.dwg / 1=1 / 9-21-94 / TLP

3.1.2 Vapor Monitoring Point Construction

A typical multi-depth VMP installation for this site is shown in Figure 3.3. The VMPs will be installed with a drill rig using hollow stem augers. The VMP screens and casings will be constructed of 0.5-inch diameter PVC. The 6-inch long screens will be installed at multiple depth intervals of approximately 3.5-4 feet, 7.5-8 feet, and 11.5-12 feet at each VMP location. These proposed monitoring depths assume that the seasonal high water table is approximately 13 feet bgs in the test area. It is possible that the proposed screened interval at 11.5-12 feet may be submerged if higher water table conditions exist. If it is apparent during drilling activities that the water table will be exceptionally high at the site (i.e., less than 11 feet bgs), then only two shallow VMP screens will be installed. In this case, the two screened depths would be adjusted accordingly to equally-spaced intervals in the unsaturated zone. Additionally, soil lithology and zones of apparent contamination will be primary factors in placing the VMP screens. For example, VMP screens may be placed in both high-permeability and lower-permeability soil layers to monitor soil gas conditions, oxygen diffusion, and respiration rates in these zones.

Multi-depth monitoring will confirm that the entire soil profile is receiving oxygen and will be used to measure fuel biodegradation rates at various depths in the soil profile. The annular space between these monitoring point screens will be sealed with bentonite to isolate the monitoring intervals. Data from the background vapor monitoring point will also be used to determine the relative natural diffusion of atmospheric oxygen into the shallow soils. Additional details on vapor monitoring point construction are found in Section 4 of the protocol document.

3.2 Handling of Soil Boring Cuttings

Cuttings from all soil borings and any remaining waste soils will be collected in DOT-approved, 55-gallon metal drums. The containers will be labeled and then placed in a designated Pope AFB hazardous material storage area. These waste soils will become the responsibility of Pope AFB and will be analyzed, handled, and disposed of in accordance with the current procedures for ongoing remedial investigations. This project is expected to generate less than five 55-gallon drums of soil cuttings.

3.3 Soil and Soil Gas Sampling

3.3.1 Soil Sampling

Three soil samples will be collected from the pilot test area during installation of the VWs and VMPs. Soil samples will be collected using a 3-inch diameter by 2-foot long split spoon sampler. A total hydrocarbon analyzer (see protocol document, Section 4.5.2) will be used during the soil borings to screen each soil sample interval for fuel contamination. Samples will be split for laboratory analysis and for field TVH screening. One sample will be collected from the most contaminated interval of one VW. One soil sample will be collected from the interval of highest apparent contamination in two of the borings for the VMPs. The samples will be transferred from the split spoon sampler directly to the sample containers. Soil samples submitted to the laboratory will be analyzed for TPH, BTEX, soil moisture, pH, particle sizing, alkalinity, total iron and nutrients.

A photoionization detector (PID) or total hydrocarbon vapor analyzer (see protocol Section 4.5.2.) will be used to insure that breathing zone levels of volatiles do not exceed 1 ppmv while conducting soil borings. Three soil samples from the most contaminated interval of the VMPs and VW will be submitted for laboratory analyses. Samples will be labeled following the nomenclature specified in the protocol document (Section 5.5), wrapped in protective plastic, and placed in an ice chest for shipment. A chain of custody form will be filled out and the ice chest shipped to the PACE, Inc. laboratory in Huntington Beach, California for analysis. This laboratory has been audited by the U.S. Air Force and meets all quality assurance/quality control and certification requirements for the State of California.

3.3.2 Soil Gas Sampling

Once the VMPs are installed and adequately purged, soil gas samples will be collected from the VMPs using SUMMAR canisters. Three SUMMAR canister soil gas samples will be collected, one from the most contaminated VW and one each from the VMPs closest to and furthest from that VW. Quantitative soil gas samples will be used to predict potential air emissions, to determine the reduction of BTEX and TVH during the extended test, and to detect potential migration of these vapors from the source area.

Soil gas samples will be placed in a small box and packed with foam pellets for protection during shipment. SUMMAR canister samples will not be placed on ice to prevent condensation of hydrocarbon compounds. A chain-of-custody form will be completed and shipped with the samples to the Air Toxics, Inc. laboratory in Folsom, California. The soil gas samples will be analyzed for BTEX compounds and TVH.

3.4 Blower System

Either a 1-HP regenerative blower or a 1-HP rotary vane blower will be used to conduct the initial air permeability test at this site. A 1-HP Gast model R4110-2 explosion-proof, regenerative-type centrifugal blower will be installed for extended pilot testing at this site if initial air permeability testing demonstrates that this blower will meet the test design performance criteria. Air injection will be used to provide oxygen to soil bacteria and to minimize emissions of volatiles to the atmosphere. Figure 3.4 is a schematic of a typical air injection system that will be used for extended pilot testing at this site.

The maximum power requirement anticipated for this pilot test is a 230-Volt, single-phase, 30 Amp service. ES understands that electrical power was removed from this site during facility demolition. The base will need to restore electrical service to the site. Although only 30-Amp service is needed to operate the single test blower, ES recommends that the base install 100-Amp service to this site to support future equipment installations associated with site remediation. Additional details on power supply requirements are described in Section 5.0, Base Support Requirements.

4.0 EXCEPTIONS TO PROTOCOL PROCEDURES

The testing procedures that will be used to measure the air permeability of the soil and *in-situ* respiration rates are described in Sections 4 and 5 of the attached protocol document. No deviations from the established field testing protocols are anticipated.

72240725.dwg / 1=1 / 9-21-94 / TLP

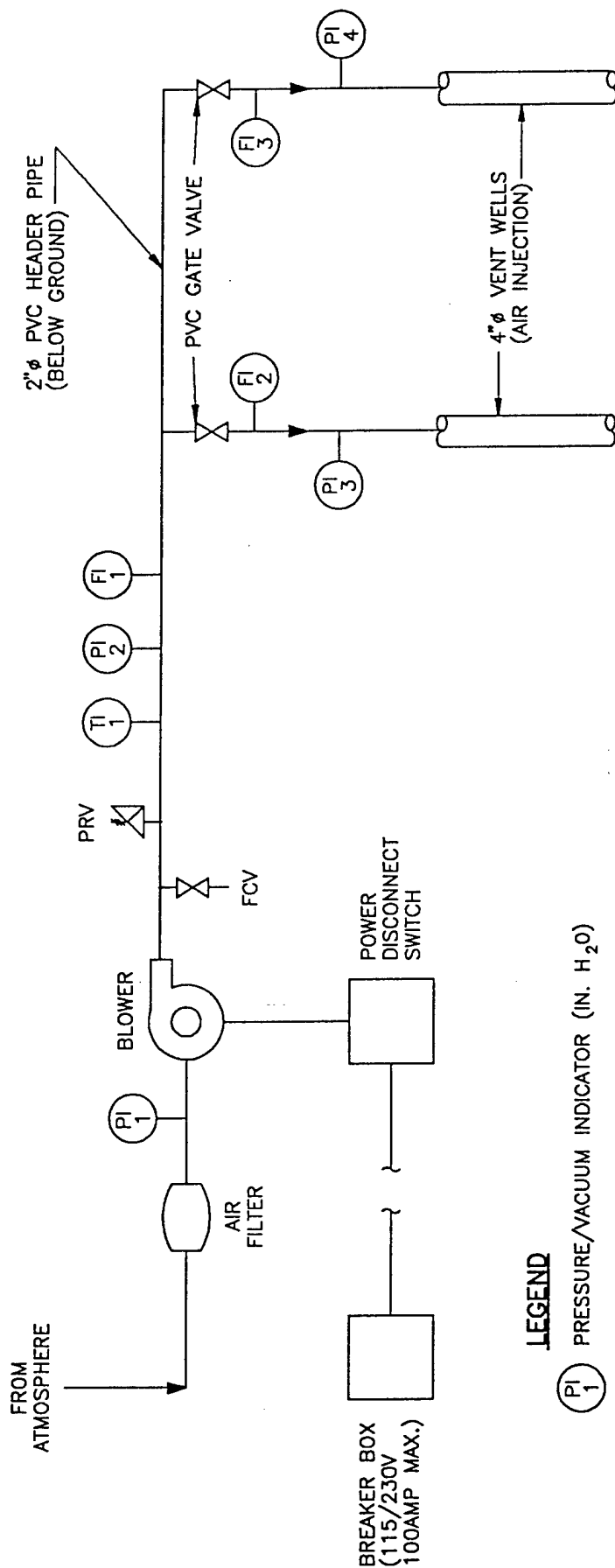

DRAWING IS NOT TO SCALE

**Blower System Instrumentation
Diagram for Air Injection**

IRP Site ST-08
Pope AFB
Fayetteville, North Carolina

LEGEND

- PI 1 PRESSURE/VACUUM INDICATOR (IN. H₂O)
- TI 1 TEMPERATURE INDICATOR (°F)
- FI 1 AIR FLOW MEASURING PORT
- FCV FLOW CONTROL VALVE (MANUAL AIR BLEED)
- PRV PRESSURE RELIEF VALVE (AUTOMATIC)

Note: Blower diagram shown is for permanent installation for extended testing.

One exception to the typical test designs presented in the protocol document is the installation of two vent wells. This design is necessary to maximize the radius of oxygen influence throughout the test area and to minimize potential short-circuiting of air. Air flow rates to individual wells can then be reduced without affecting the test results. The VW screens may also be installed several feet into the water table if water levels are elevated during the VW installations.

5.0 BASE SUPPORT REQUIREMENTS

5.1 Test Preparation

The following base support is needed prior to the arrival of the Engineering-Science test team:

- Confirmation of regulatory approval for the pilot test.
- Assistance in obtaining a digging permit at Site ST-08.
- A breaker box mounted to a power pole on the site that can supply 230-Volt, single-phase, 30-Amp service (minimum) for the initial and extended pilot test. The breaker box should be located five feet above the ground and include one 230-Volt outlet and two 110 volt outlets to support pilot testing equipment. The base should also provide assistance in wiring the permanent blower directly to a power disconnect switch and to the breaker box.
- Provide any paperwork required to obtain gate passes and security badges for approximately two ES employees and three drilling subcontractor employees. Vehicle passes will be needed for three trucks.

During the initial two-week pilot test, the following base support is needed:

- Twelve square feet of desk space and a telephone in a building located as near to the site as practical.
- A decontamination pad where the drilling subcontractor can clean the drill rig and augers.
- Accept responsibility for soil cuttings from vent wells and monitoring point borings, including any drum sampling to determine disposal requirements.
- The use of a fax machine for transmitting 15 to 20 pages of test results.

During the one year extended pilot test at Site ST-08:

- Check the blower system at the site once a week to ensure that it is operating and to record the air injection pressures at each VW. Engineering-Science will provide a brief training session and an O&M checklist for this procedure.
- Notify Mr. Grant Watkins, Engineering-Science, Inc., Cary, NC (919) 677-0080; or Mr. Doug Downey, Engineering-Science, Inc. Denver, CO (303) 831-8100; or Lt. Maryann Jenner of the AFCEE, (210) 536-4364, if the blower or motor stop operating.
- Arrange site access for an Engineering-Science technician to conduct *in-situ* respiration tests approximately six months and one year after the extended pilot test begins.

5.2 Permit Requirements

Base personnel are responsible for obtaining all permits from the North Carolina Department of Environment, Health, and Natural Resources (NCDEHNR) that are required to perform the test as described in this work plan. If required, Engineering-Science will assist this effort by providing test design criteria and reference documents for regulatory review. Unless directed by AFCEE or Pope AFB, no direct contact will be made between Engineering-Science, Inc. and the regulatory agencies.

No permits for construction are anticipated for either the VWs or VMPs since these wells will be located on base property and they will not be used for liquid or vapor recovery purposes. As described in the bioventing protocol document, the initial respiration pilot testing requires a 3 percent helium injection into the VMPs as a tracer to check for VMP leaks and to monitor helium diffusion in the subsurface. Current North Carolina regulations do not allow subsurface injection of any liquids or gases except for clean, atmospheric air without a State underground injection control permit. Under the strictest interpretation of the regulations, injection of any substance other than atmospheric air requires that the VMPs be permitted as Class V injection wells.

ES's recent experience with this issue has determined that North Carolina is considering modifying this regulation so that research and experimental technology studies using injected tracers can be performed with less stringent permitting requirements. Currently, each study request is being reviewed and considered on a case-by-case basis. The permit applicant is usually asked to provide supporting toxicological data showing that the proposed tracer substance to be injected is not a health or ecological hazard and will not contravene any State groundwater standards. ES will assist the base in obtaining a permit and/or regulatory approval to inject helium into subsurface soils during the initial respiration tests, to the extent that this approval can be obtained in a timely manner. If it appears that the permitting and/or approval process will significantly delay implementation of this bioventing study, ES will recommend that the testing be performed without helium injection.

6.0 PROJECT SCHEDULE

The following schedule is contingent upon timely approval of this pilot test work plan:

Event	Date
Draft Test Work Plan to AFCEE/Pope AFB	September 30, 1994
Approval To Proceed	October 12, 1994
Begin Initial Pilot Test	November 7, 1994
Complete Initial Pilot Test	November 16, 1994
Interim Results Report	December 22, 1994
Respiration Test	May, 1995

After a period of one year, a decision will be made by AFCEE and the base to either remove the system or to expand the system for full-scale remediation at the site.

7.0 POINTS OF CONTACT

Mr. Robert Byrd
23rd CES/CEV
560 Interceptor Rd.
Pope AFB, North Carolina 28308-2890
(910) 394-4397

Lt. Col. Ross Miller/Lt. Maryann Jenner
AFCEE/ERT
8001 Arnold Drive, Building 642
Brooks AFB, Texas 78235-5357
(210) 536-4331/4364

Mr. Grant Watkins, P.G.
Engineering-Science, Inc.
401 Harrison Oaks Boulevard
Suite 210
Cary, North Carolina 27513
(919) 677-0080

Mr. Doug Downey
Engineering-Science, Inc.
1700 Broadway
Suite 900
Denver, Colorado 80290
(303) 831-8100

8.0 REFERENCES

- Metcalf & Eddy, Inc., 1993. *Phase 2 Remedial Investigation Report, Pope Air Force Base, North Carolina*. January, 1993.
- Schipf, Robert G., 1961. *Geology and Groundwater Sources of the Fayetteville Area*, Groundwater Bulletin No. 3, North Carolina Department of Water Resources, Raleigh, North Carolina.
- United States Geological Survey, 1989. *Hydrogeologic Framework of the North Carolina Coastal Plain Aquifer System*, U.S.G.S. Open-File Report 87-690.

PART II
DRAFT
INTERIM BIOVENTING PILOT TEST RESULTS REPORT
IRP SITE ST-08
FORMER FUEL OIL STORAGE FACILITY
POPE AFB, NORTH CAROLINA

Prepared for:

AIR FORCE CENTER FOR ENVIRONMENTAL EXCELLENCE
BROOKS AFB, TEXAS

and

23RD CES/CEV
POPE AFB, NORTH CAROLINA

May 1995

Prepared by:

Parsons Engineering Science, Inc.
401 Harrison Oaks Blvd., Suite 210
Cary, North Carolina

CONTENTS

	<u>Page</u>
1.0 Pilot Test Design and Construction	II-1
1.1 Additional Site Investigations	II-3
1.2 Vent Well Installations	II-4
1.3 Vapor Monitoring Point Installations	II-7
1.4 Air Injection Piping System Installation	II-10
2.0 Pilot Test Soil and Soil Gas Sampling Results	II-10
2.1 Soil Sampling Results	II-10
2.2 Soil Gas Sampling Results	II-11
2.3 Lithologic characterization	II-11
3.0 Pilot Test Results	II-13
3.1 Initial Soil Gas Chemistry	II-13
3.2 Air Permeability Tests	II-15
3.2.1 Air Permeability Test #1	II-15
3.2.2 Air Permeability Test #2	II-15
3.3 Oxygen Influence	II-17
3.4 <i>In Situ</i> Respiration Tests	II-19
3.5 Potential Air Emissions	II-21
4.0 Recommendations	II-23
5.0 References	II-23

FIGURES

<u>No.</u>	<u>Title</u>	<u>Page</u>
1.1	Bioventing Pilot Test Location	II-2
1.2	Vent Wells, VMPs, and Piping Locations	II-5
1.3	Hydrogeologic Cross Section	II-6
1.4	As-Built Air Injection Vent Well Construction	II-8
1.5	As-Built Monitoring Point Construction Detail	II-9

TABLES

<u>No.</u>	<u>Title</u>	<u>Page</u>
2.1	Soil and Soil Gas Analytical Results	II-12
3.1	Initial Soil Gas Chemistry	II-14
3.2	Pressure Response - Air Permeability Test #1	II-16
3.3	Pressure Response - Air Permeability Test #2	II-18
3.4	Influence of Air Injection At Vent Wells	II-20
3.5	Apparent Oxygen Utilization Rates	II-22

APPENDICES

- Appendix A Soil Boring Logs and Well Construction Records
- Appendix B Oxygen Utilization Data Plots

PART II

DRAFT

INTERIM BIOVENTING PILOT TEST RESULTS REPORT IRP SITE ST-08 FORMER FUEL OIL STORAGE FACILITY POPE AFB, NORTH CAROLINA

An initial bioventing pilot test was performed at IRP Site ST-08, Former Fuel Oil Storage Facility, located between Boxcar Street and Taxiway B at Pope Air Force Base (AFB), North Carolina (see Figure 1.1). Test well installations and initial field testing were conducted at the site from February 13 through March 15, 1995. The purpose of this Part II report is to describe the results of the initial pilot test at Site ST-08 Former Fuel Oil Storage Facility, and to make specific recommendations for extended testing to determine the long-term impact of bioventing to remediate site contaminants. Descriptions of the history, geology, and contaminants of this site are outlined in Part I of this report, Bioventing Pilot Test Work Plan.

1.0 PILOT TEST DESIGN AND CONSTRUCTION

Two air injection vent wells (VWs), five permanent vapor/pressure monitoring points (VMPs), and an air injection piping system were installed from February 13-15, 1995 by the Cary, North Carolina office of Parsons Engineering Science, Inc. (Parsons ES; formerly Engineering-Science, Inc.). Subcontractor support was provided by American Environmental Drilling Services, Inc. (AEDS) of Pinehurst, North Carolina for drilling and subsurface piping installation services. The system installation and testing was directed by Mr. Grant Watkins, P.G., the Parsons ES site manager. Figure 1.1 shows the VW and VMP locations relative to other site features. The following sections describe in more detail the final design, installation, and testing of the bioventing system at this site.

Based on site conditions encountered by Parsons ES, minor changes were made when executing the original work plan for the bioventing system construction, layout, and testing. As stated in the work plan (Part I of this report), the original system design proposed that the VWs be placed on 40-foot centers. The VW spacing was increased to 50 feet so that a larger volume of contaminated soil could be treated during the extended bioventing pilot test. The relatively high water table also required that the VMPs be constructed with only two screened intervals in the unsaturated zone. Additionally, helium injection was not conducted during respiration testing since regulatory permits and restrictions associated with this activity would have delayed the bioventing project.

Figure 1.1

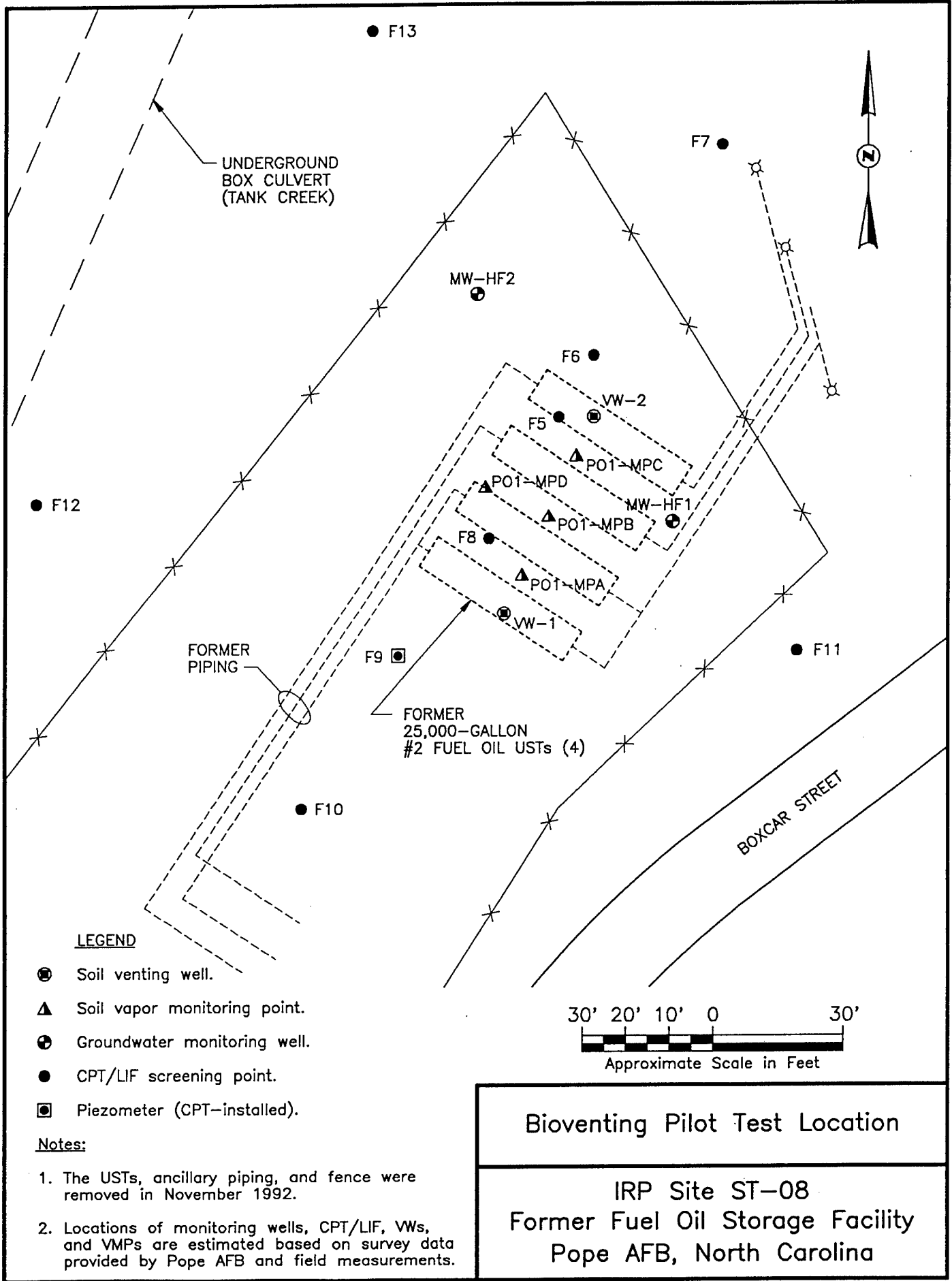

LEGEND

- Soil venting well.
- ▲ Soil vapor monitoring point.
- ⊕ Groundwater monitoring well.
- CPT/LIF screening point.
- ▣ Piezometer (CPT-installed).

Notes:

1. The USTs, ancillary piping, and fence were removed in November 1992.
2. Locations of monitoring wells, CPT/LIF, VWs, and VMPs are estimated based on survey data provided by Pope AFB and field measurements.

Bioventing Pilot Test Location
IRP Site ST-08
Former Fuel Oil Storage Facility
Pope AFB, North Carolina

950043.DWG / ps:1=1 / 5-3-95 / TLP

1.1 Additional Site Investigations

Following Parsons ES's submittal of the Draft Bioventing Work Plan (September 1994), additional investigations were conducted by various contractors to further characterize subsurface conditions at the Site ST-08 Former Fuel Oil Storage Facility. On September 20, 1994 the U.S. Army Corps of Engineers (COE), under contract to Pope AFB, installed two groundwater monitoring wells (HF-1 and HF-2) in the vicinity of the former UST excavation (see Figure 1.1). Wells HF-1 and HF-2 were the first wells installed at this site to monitor groundwater conditions. Both wells were constructed with 4-inch stainless steel screens and casings. The wells were screened across the water table surface with approximate screened intervals from 7.5 feet to 17.5 feet below ground surface (bgs).

Parsons ES returned to the site on October 12, 1994 to collect water levels and to measure soil gas composition in monitoring wells HF-1 and HF-2. On that date, well HF-2 had 0.55 feet of non-aqueous phase liquid (NAPL) fuel, or "free product", in the well and the water table surface was positioned at 14.24 feet bgs. Well HF-1 had a NAPL fuel sheen (approximately 0.01 feet) and a water table level at 12.55 feet bgs. Water and NAPL fuel levels were remeasured in these wells during subsequent visits to the site in February and March 1995. NAPL fuel thicknesses were 1.34 feet (2/13/95), 0.14 feet (2/23/95) and 0.01 feet (3/13/95) at well HF-2. In well HF-1, NAPL fuel thicknesses varied from 0.43 feet (2/13/95) to 0.46 feet (2/23/95) to 0.50 feet (3/13/95). Water table fluctuations of 0.78 feet at HF-1 to 3.14 feet at HF-2 observed during this period correlated to the dynamic NAPL fuel thicknesses measured in the wells.

During Parsons ES's October 12, 1994 site visit, both wells were temporarily fitted with an air-tight coupling and gas ball valve to collect soil gas samples from the headspace of the wells. The headspace of each well was purged with a small vacuum pump to evacuate several well headspace volumes prior to measuring the soil gas composition. The soil gas samples were field-screened for oxygen (O₂), carbon dioxide (CO₂), and total volatile hydrocarbons (TVH) using portable field instruments. Results showed that soil gas is oxygen-deficient at well HF-1 (4.5% O₂) and at HF-2 (1.9% O₂). Carbon dioxide concentrations ranged from 15.0% at HF-1 to 10.1% at HF-2. Headspace TVH concentrations exceeded 10,000 parts per million by volume (ppmv) at both wells. Parsons ES rescreened soil gas composition in both monitoring wells prior to conducting the air permeability and respiration tests in March, 1995. Soil gas was essentially oxygen-depleted in both wells (0.4% to 0.0% O₂) during these subsequent measurements.

In January 1995, the Air Force Center for Environmental Excellence (AFCEE) performed a preliminary site screening at Site ST-08 Former Fuel Oil Storage Facility as part of a national research and development program and to identify candidate sites for future innovative technology programs. The site screening was accomplished using a modified cone penetrometer technology (CPT) rig, also known as the *Site Characterization and Analysis Penetrometer System (SCAPS)*, owned and operated by the COE-Kansas City District. The SCAPS cone penetrometer rig is equipped with a fiber optics laser system that uses Laser Induced Fluorescence (LIF) to detect oily-phase petroleum contaminants in soils and groundwater. The output of the fiber optics

LIF probe establishes the fluorescence intensity and wavelength response to determine the relative concentrations and types of oily-phase fuel present in the subsurface.

Nine direct-push sampling points were installed during the CPT/LIF probe investigation. The approximate locations of these points are shown in Figure 1.1. One of the sampling points (F5) hit a solid obstruction with probe refusal at 13 feet bgs. A 1.5-inch diameter piezometer was installed at CPT sampling point F9 for NAPL fuel monitoring. Lithologies established from the CPT cone resistance and sleeve friction indicated that soils at the site are a very heterogeneous mixture of sands, silts, and clays. The LIF probe readings indicated numerous zones with high fluorescence intensity indicative of oily-phase contamination. Parsons ES used these results, as well as data from monitoring wells HF-1 and HF-2, to facilitate the final design and placement of the bioventing VWs and VMPs.

1.2 Vent Well Installations

Two air injection VWs were installed at the site for interim testing and long-term use during the bioventing study. The VWs were located within the center of the oxygen-depleted, fuel-contaminated area identified during the previous soil gas surveys and CPT/LIF studies. The VWs were installed within the former UST excavation area in an approximate northeast-southwest orientation. Additionally, the VWs were also placed at a sufficient distance from existing monitoring wells and piezometers to prevent air short-circuiting at these installations. Figure 1.1 shows the location of the VWs relative to the site features. Figure 1.2 shows the VWs and VMP detailed layout for the bioventing system.

The VWs were installed using a mobile drill rig advancing 8.5-inch nominal diameter hollow stem augers. Soil samples were collected at approximate 2-foot intervals using a split spoon sampling device advanced through the hollow stem augers. The borehole for vent well PO1-VW1 was advanced to a total depth of 13.5 feet bgs, where water-saturated conditions were encountered. The borehole for vent well PO1-VW2 could only be advanced to 12.5 feet bgs, where a solid obstruction and auger refusal were encountered. This is the same general area and depth where CPT/LIF sampling point F5 had probe refusal. The auger response and wear observed on the drill bit indicated that the object is made of concrete. The solid obstruction is most likely either a concrete tank tie-down slab or saddle that was not removed during the UST excavations. Parsons ES noted that soils located several feet above the subsurface object were water-saturated.

During borehole advancement, soil lithologies were characterized and several of the samples from each borehole were screened for TVH using a portable field hydrocarbon analyzer. Using the TVH field screening results to establish relative contamination, one soil sample from vent well PO1-VW1 was submitted for laboratory analyses. Lithologic descriptions obtained during VW and VMP installations were used to develop a hydrogeologic cross section, shown in Figure 1.3. Appendix A contains borehole logs and well construction records for the VWs and VMPs.

Both VWs were constructed using 4-inch diameter PVC screens and casing installed in the boreholes. Groundwater was encountered at various depths in the boreholes, ranging from 12.5 feet bgs at PO1-VW1 to only 9 feet bgs at PO1-VW2. Parsons ES

Figure 1.2

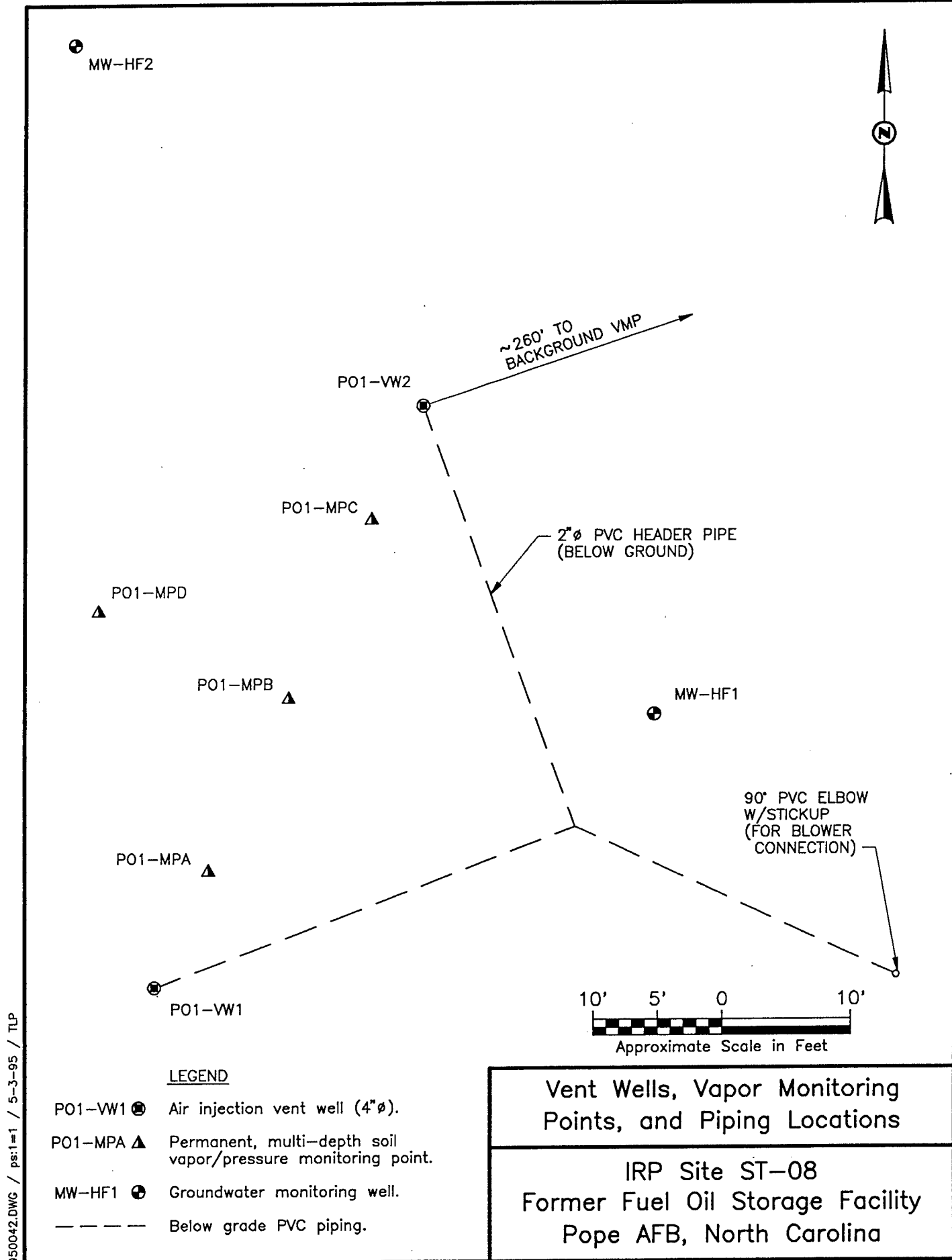
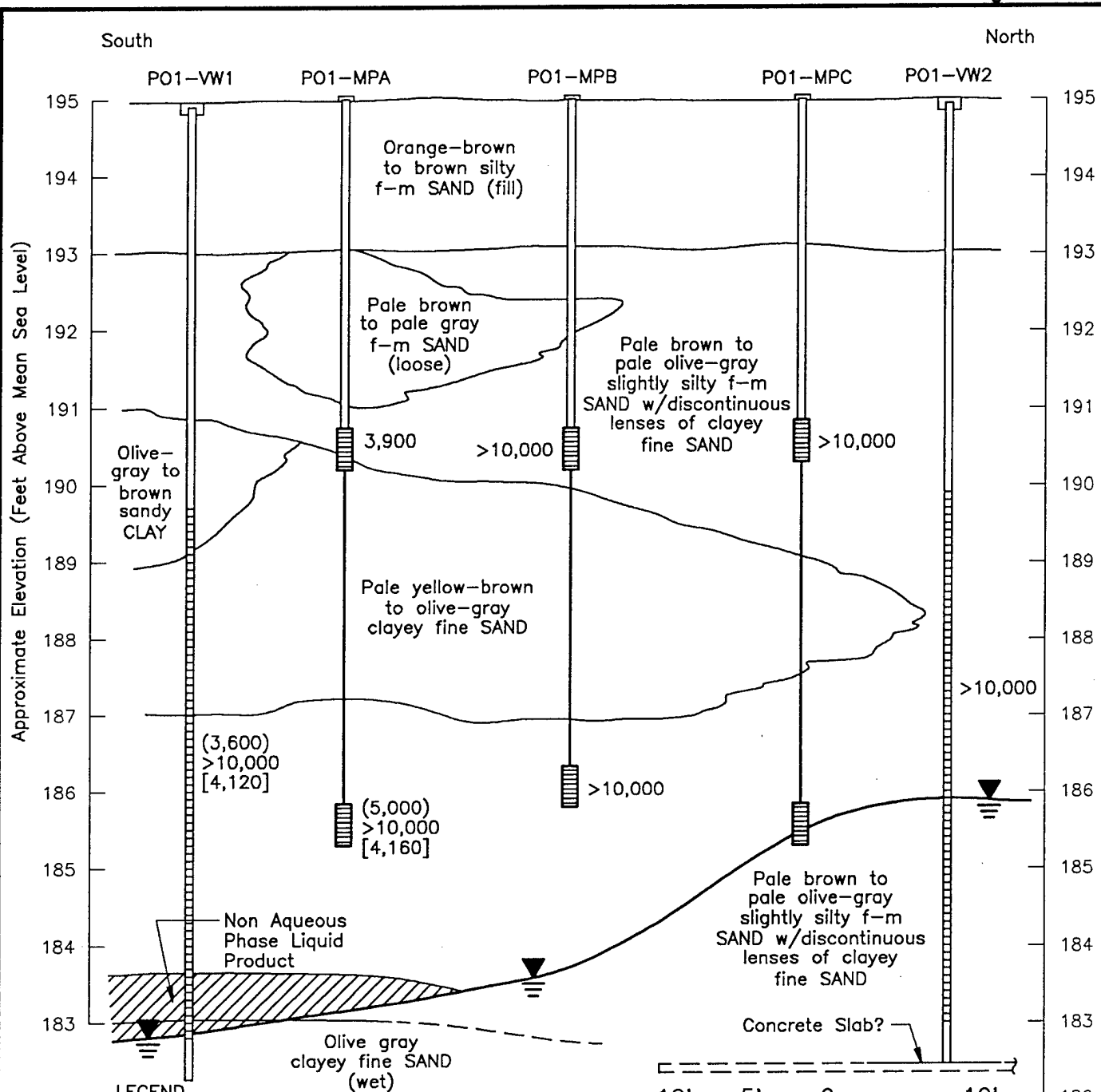
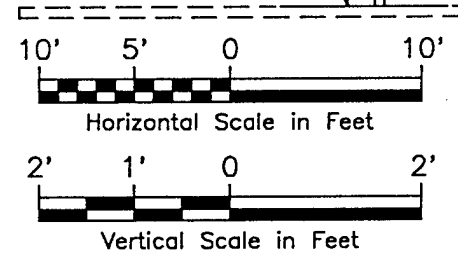

Figure 1.3



- LEGEND**
- Water table surface.
 - Lithologic contact, dashed where inferred.
 - Monitoring point casing interval.
 - Monitoring point screen interval (6" long).
 - (3,600) Lab SUMMA canister results, total volatile petroleum hydrocarbons (ppmv).
 - [4,120] Lab results, soil total recoverable petroleum hydrocarbons (mg/kg).
 - 3,900 Field screening results, soil total volatile hydrocarbons (ppmv).
- Note: Water table depth shown was measured on 3-13-95 (feet BLS).



Hydrogeologic Cross Section

IRP Site ST-08
Former Fuel Oil Storage Facility
Pope AFB, North Carolina

72240732.DWG / 1=1 / 5-16-95 / TLP

installed the bottom of each VW at or beneath the water table to average total depths of 12.5 feet bgs. The top of each screen was placed at approximately 5 feet bgs, which is sufficient height above the water table surface to ensure that an adequate length of screen is exposed in the unsaturated zone for air injection. Exposed screen lengths ranged from 4 feet (PO1-VW2) to 6 feet (PO1-VW1) above the water table at the time of installation.

Figure 1.4 shows a typical construction schematic for the VWs. Two threaded screen sections (one 2.5-foot and one 5.0-foot section) were used to construct each VW. Both sections consist of 0.020-inch slotted "high-yield" screens. The "high-yield" screens have a greater number of slots per linear foot than do conventional monitoring well screens. The increased open area per linear foot of screen reduces pressure losses associated with the screen and improves air exchange between the VW and the formation.

Each VW was completed with a solid 4-inch PVC riser finished near ground surface inside a 2'x2' flush-mount steel well vault. The borehole annulus around the well casing was completed with a bentonite plug and cement grout to seal the borehole from the surface and to minimize short-circuiting of air around the borehole. The locking well vault was set in a concrete pad. As shown in Figure 1.4, a PVC header pipe was installed inside each well vault to connect the VW to the blower.

1.3 Vapor Monitoring Point Installations

Four multi-depth, vapor/pressure monitoring points (VMPs), each having two screened intervals, were installed around the bioventing test area. A fifth, single-depth background VMP was installed outside of the contaminated bioventing test area to monitor background soil gas conditions. Three VMPs (PO1-MPA, PO1-MPB, PO1-MPC) were installed on 10-foot centers on an axis between the two VWs, as depicted in Figure 1.2. A fourth VMP (PO1-MPD) was installed 30 feet from both VWs toward the west. Boreholes for the VMPs were advanced using either a stainless steel hand auger or hollow stem augers. Soil samples were collected from the boreholes at regular intervals and screened in the field for TVH concentrations. Samples from two of the VMPs were submitted for laboratory analyses (see Section 2.1 below).

Each of the VMPs was constructed using 0.5-inch threaded PVC screen and casing. The top of each VMP was fitted air tight with a gas ball valve equipped with a hose barb. Both screened intervals of vapor monitoring point PO1-MPB were equipped with thermocouple probes to measure soil temperature. All four VMPs were similarly constructed as multi-depth monitoring points with two 6-inch long screens placed at various depths in the unsaturated zone. The bottoms of the shallow screens were installed to depths ranging from 4.7 to 4.8 feet bgs in each VMP borehole. The bottoms of the deeper screens were positioned at depths ranging from 8.7 to 9.7 feet bgs. These screened intervals are expected to remain above the water table for most of the year, with the possible exception of anomalously-high water table conditions observed in the vicinity of PO1-VW2 and PO1-MPC. Figure 1.5 shows the typical construction schematic for the VMPs and summarizes the constructed screened intervals at each VMP. Borehole logs and VMP construction records are found in Appendix A.

Figure 1.4

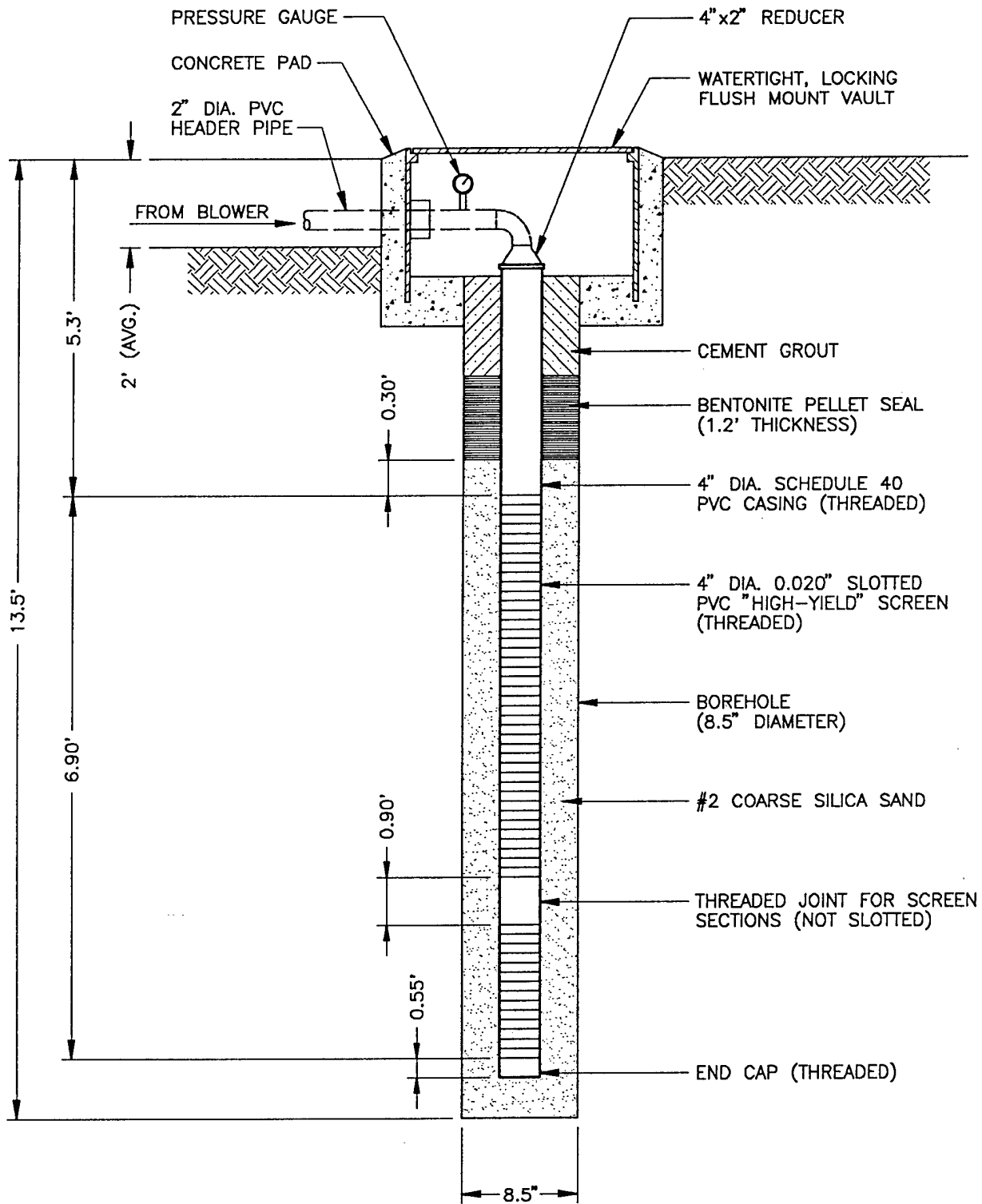

NOTES:

1. Drawing is not to scale.
2. Well schematic is typical for P01-VW1. Vent well P01-VW2 has similar construction but is screened from 5.1' to 12.0' bgs, in a borehole with total depth of 12.55' bgs.
3. Water table surface was 12.13' bgs in P01-VW1 on 3/13/95.

**As-Built Air Injection
Vent Well Construction**

**IRP Site ST-08
Former Fuel Oil Storage Facility
Pope AFB, North Carolina**

72240733.DWG / 1=1 / 5-16-95 / TLP

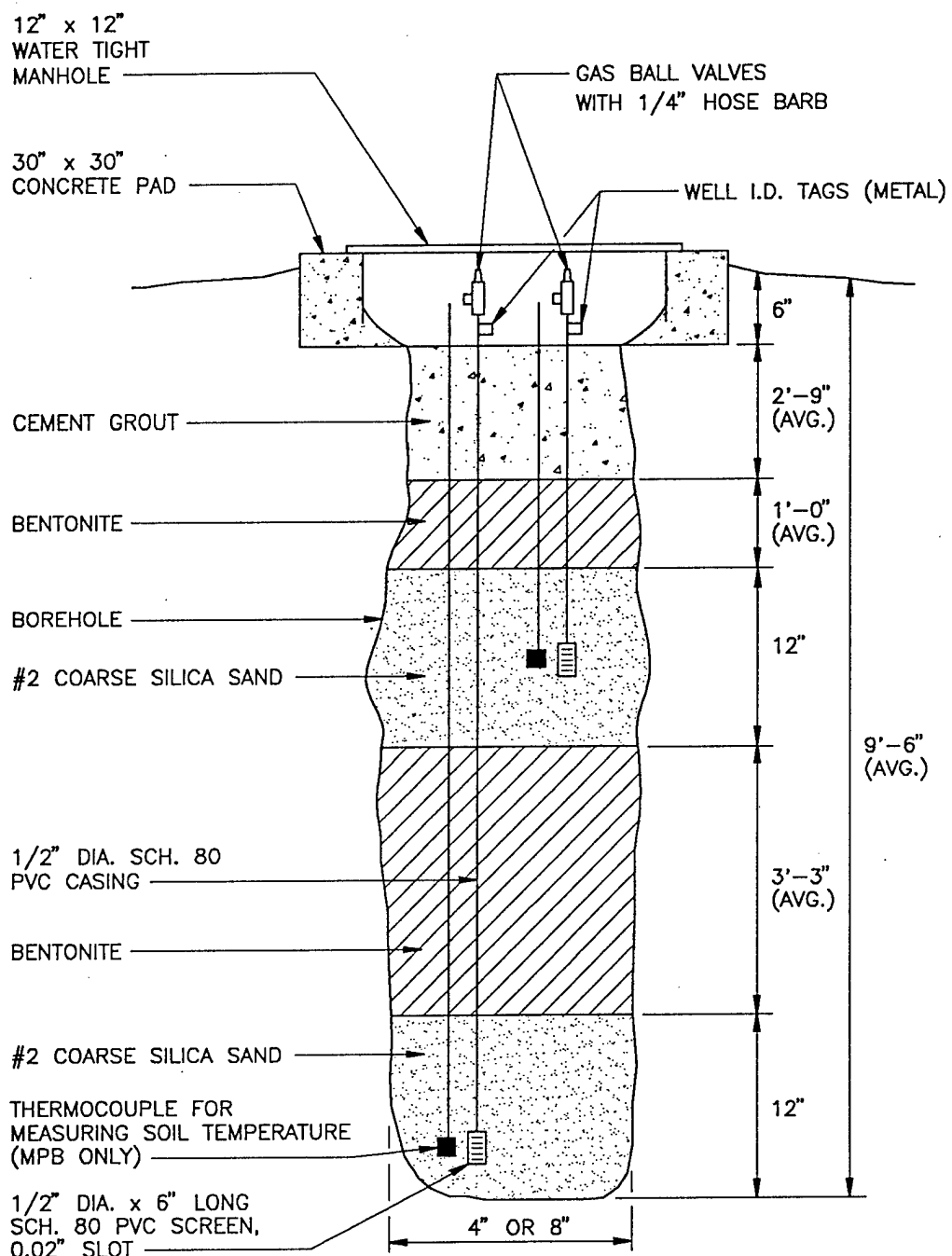

MONITORING POINT CONSTRUCTION DETAILS

Monitoring Point No.	Screened Intervals (FT)	Thermocouple Depths (FT)
PO1-MPA	4.3-4.8/9.2-9.7	NA
PO1-MPB	4.3-4.8/8.7-9.2	4.8/9.2
PO1-MPC	4.2-4.7/9.2-9.7	NA
PO1-MPD	4.2-4.7/8.2-8.7	NA
PO1-BG1	6.2-6.7	NA

Note:
 1. Construction schematic is typical for all monitoring points.

DRAWING IS NOT TO SCALE

**As-Built Monitoring Point
 Construction Detail**

**IRP Site ST-08
 Former Fuel Oil Storage Facility
 Pope AFB, North Carolina**

950041.DWG / ps:1=1 / 5-3-95 / TLP

A permanent background VMP, designated as PO1-BG1, was installed approximately 260 feet east of the VWs using a hand auger. The background VMP, completed to a total depth of 6.7 feet bgs, was used to monitor background soil gas conditions not affected by hydrocarbon contamination associated with the former fuel oil storage facility. Parsons ES measured baseline soil gas conditions in PO1-BG1 one week after this VMP was installed. The soil gas O₂ concentration at PO1-BG1 was 13.2 percent, CO₂ concentration was 4.2 percent, and soil gas TVH was 44 ppmv. These results indicate that the background VMP may not have been located outside the area of soil vapor contamination, or some other factor may have depressed the soil gas oxygen in this area. When Parsons ES returned to the site one month later to conduct respiration tests, background point PO1-BG1 was submerged below the water table as a result of recent precipitation events. As discussed in Section 3.4 of this Part II report, a background monitoring well upgradient of the site was used as an alternate VMP to conduct a background respiration test.

1.4 Air Injection Piping System Installation

A subsurface piping system was installed to connect each VW to a common header pipe that will eventually be connected to an air injection blower for extended bioventing testing. The piping system was constructed of 2-inch diameter, Schedule 40 PVC pipe. Figure 1.2 shows the as-built layout of the existing piping system and the proposed blower shed location. Each manifolded segment of the piping system will be equipped with a PVC ball valve so that the air flow to each VW can be controlled individually. This configuration will allow one VW to be shut down while the other VW receives air injection.

Electrical power is currently not available at this bioventing project site and a permanent blower has not been installed. Parsons ES used a Gast model 1070 rotary vane compressor pump operated by a gas-powered generator to perform the initial air permeability tests at the site. Due to the site's proximity to Taxiway B and the associated airfield buffer zone requirements, Pope AFB is currently pursuing an airfield waiver that will allow a permanent, above-grade structure to be constructed inside this buffer zone. Once electrical power is brought to the site and a permanent blower is installed and wired for service, air injection will commence for the one-year pilot test.

2.0 PILOT TEST SOIL AND SOIL GAS SAMPLING RESULTS

2.1 Soil Sampling Results

During installation of the VW and VMP boreholes, Parsons ES collected soil samples at regular intervals for field headspace screening for hydrocarbon organic vapors. Three sets of soil samples were collected for laboratory analyses, one set each from PO1-VW1 (10-foot depth), PO1-MPA (9.5-foot depth), and PO1-MPD (9-foot depth). Organic vapor concentrations generally increased with depth, although some of the shallow soils had zones with elevated organic vapor readings. For comparative evaluation, soil samples for laboratory analyses were collected from approximately the same unsaturated zone intervals that the deeper screens were installed in the VMPs (see Figure 1.3).

The three sets of soil samples were analyzed by the PACE, Inc. laboratory in Lenexa, Kansas for these parameters: total recoverable petroleum hydrocarbons (TRPH); benzene, toluene, ethylbenzene, xylenes (BTEX); iron; alkalinity; pH; total Kjeldahl nitrogen (TKN); phosphorus; percent moisture; and particle size distribution. Table 2.1 summarizes the results of these analyses. TRPH concentrations ranged from 1,290 milligrams per kilogram (mg/kg) at PO1-MPD-9 to 4,160 mg/kg at PO1-MPA-9.5. Benzene, toluene, ethylbenzene, and total xylenes were not detected in any of the soil samples above the detection limits for each of these compounds.

In addition to the soil samples collected within the pilot test area, one background soil sample was collected at PO1-BG1-6.5 for TKN analysis. This sample is intended to establish a representative background TKN concentration for uncontaminated soils at the base. The analytical result showed no detection of TKN above the 40 mg/kg detection limit.

2.2 Soil Gas Sampling Results

Three soil gas samples were collected using SUMMAR^R canisters, one each from PO1-MPA-9.7, PO1-MPD-8.7, and PO1-VW1. The samples were collected according to bioventing program protocols and were analyzed for total volatile hydrocarbons (TVH) and BTEX compounds. Analytical results indicate soil gas TVH concentrations ranging from 3,100 ppmv at PO1-MPD-8.7 to 5,000 ppmv at PO1-MPA-9.7. Soil gas BTEX concentrations were relatively low, ranging from no detection (ND) to 68 ppmv of toluene for the individual BTEX compounds. Vent well PO1-VW1 contained the highest total BTEX soil gas concentrations of the three monitoring points that were sampled, possibly due to the floating free product on the water table in this well. Benzene was not detected in any of the soil gas samples. These results indicate that potential benzene emissions during bioventing should not be a concern for this site. Table 2.1 summarizes the soil gas sampling results.

2.3 Lithologic Characterization

Soils encountered during the VMP and VW installations consisted primarily of olive-gray to brown, silty fine to medium sands and clayey sands (see Figure 1.3). The soils in the pilot test area were disturbed and translocated during the UST excavations. As discussed in Part I of this report, fuel-contaminated soils excavated during the UST removals were returned to the excavation as backfill material. This created a heterogeneous mixture of disturbed soil with minimal lithologic continuity above the water table. The upper 2 feet of soil in the test area consist of a nonresidual brown to orange-brown silty sand used to backfill the excavation to its final grade.

Several discontinuous zones of pale gray, loose fine sand were identified in the subsurface. Noticeably higher concentrations of hydrocarbon vapors were present in these soils. Generally, the soils around PO1-VW1 contained a higher clay and moisture content than soils in the immediate vicinity of vent well PO1-VW2. A zone of stiff, moist to wet, clayey sand with apparent low permeability was encountered from approximately 4 to 8 feet bgs in monitoring points PO1-MPB, PO1-MPA, and PO1-VW1.

TABLE 2.1
SOIL AND SOIL GAS ANALYTICAL RESULTS
IRP SITE ST-08
FORMER FUEL OIL STORAGE FACILITY
POPE AFB, NORTH CAROLINA

<u>Analyte (Units)^{a/}</u>	<u>Sample Location-Depth</u> <u>(feet below ground surface)</u>		
	<u>VW1-10</u>	<u>MPA-9.5</u>	<u>MPD-9</u>
<u>Soil Hydrocarbons</u>			
TRPH (mg/kg)	4,120	4,160	1,290
Benzene (mg/kg)	<0.057	<0.057	<0.058
Toluene (mg/kg)	<0.057	<0.057	<0.058
Ethylbenzene (mg/kg)	<0.057	<0.057	<0.058
Xylenes (mg/kg)	<0.11	<0.11	<0.12
<u>Soil Gas Hydrocarbons</u>	<u>VW1</u>	<u>MPA-9.7</u>	<u>MPD-8.7</u>
TVH (ppmv)	3,400 ^{b/}	5,000	3,100
Benzene (ppmv)	<0.57 ^{b/}	<0.13	<0.34
Toluene (ppmv)	68 ^{b/}	3.6	2.8
Ethylbenzene (ppmv)	4.8 ^{b/}	3.3	3.9
Xylenes (ppmv)	14 ^{b/}	8.1	9.0
<u>Soil Inorganics</u>	<u>VW1-10</u>	<u>MPA-9.5</u>	<u>MPD-9</u>
Iron (mg/kg)	2,270	3,240	3,600
Alkalinity (mg/kg as CaCO ₃)	400	100	100
pH (units)	6.58	6.95	6.44
TKN (mg/kg)	<40	<40	<40
Phosphorus (mg/kg)	160	82	74
<u>Soil Physical Parameters</u>	<u>VW1-10</u>	<u>MPA-9.5</u>	<u>MPD-9</u>
Moisture (% wt.)	12.8	11.9	14.1
Gravel (%)	2.1	10.8	1.0
Sand (%)	74.3	70.8	71.8
Silt (%)	10.0	5.0	9.1
Clay (%)	13.5	13.5	18.2

a/ TRPH = Total recoverable petroleum hydrocarbons; mg/kg = milligrams per kilogram;
TVH = total volatile hydrocarbons; ppmv = parts per million, volume per volume;
CaCO₃ = calcium carbonate; TKN = total Kjeldahl nitrogen.

b/ Results averaged with duplicate sample.

Particle size analyses were conducted on several soil samples collected from the deeper unsaturated soils at the site. Sieve analyses showed from 1% to 10% gravel-size particles and from 70.8% to 74.3% sand-size particles on the three samples. Hydrometer analyses on the samples showed a silt content ranging from 5% to 10%, and a clay content of between 13.5% and 18.2%. These results confirm the field descriptions of the soil as predominantly a silty to clayey fine to medium sand.

The water table occurs from about 9.5 to 13 feet bgs at this site as measured in the VWs and the existing groundwater monitoring wells. Water level measurements made over a two-month period indicate that short-term water table fluctuations of 1 to 2 feet are possible at this site. The large hydraulic head differential between water levels in the two VWs and the monitoring wells suggests that the water table mounds in the vicinity of PO1-VW2. This mounding effect may be caused by temporary groundwater perching on the subsurface concrete slab found in this area, or by some other subsurface condition that is not readily apparent.

3.0 PILOT TEST RESULTS

Parsons ES conducted soil air permeability tests and *in situ* respiration tests at the site in March, 1995. As discussed above, pre-test soil gas samples were collected for qualitative (field screening) analyses and quantitative (laboratory) analyses prior to conducting the tests. Test procedures and results for each of the tests are discussed in the following sections.

3.1 Initial Soil Gas Chemistry

Prior to initiating any air injection, all VMPs were purged until oxygen concentrations had stabilized and then initial O₂, CO₂, and TVH concentrations were measured using portable gas analyzers. The VWs and two groundwater monitoring wells were fitted with temporary, air-tight wellhead fittings and their soil gas was also purged and sampled in a similar manner. In contaminated soils, microorganisms had depleted soil gas oxygen concentrations in all the VMPs. The deeper VMPs and the VWs had the lowest O₂ concentrations. Initial soil gas chemistry results (O₂, CO₂, TVH, temperature) obtained by field screening are listed in Table 3.1. TRPH data are also provided to demonstrate the relationship between lower oxygen levels and fuel contamination in the soils.

The intended background VMP (PO1-BG1) installed at the bioventing test site did not yield conclusive results about background soil gas conditions in the test area. As summarized in Table 3.1, initial screening of this VMP indicated oxygen-deficient soil gas (13.2% O₂). This VMP later contained water and could not be used for background respiration testing. It is not known if the oxygen-deficient soil gas is due to naturally-occurring soil conditions and/or fuel-related contamination. Parsons ES identified a clean, upgradient monitoring well (MW1-20) at IRP Site FT-01, which is located about 0.6 miles south (upgradient) of the former fuel oil storage facility. Background soil gas O₂ concentration was 18.7 percent, CO₂ was 2.1 percent, and TVH was 36 ppmv in well MW1-20 at a depth of 9 feet. Background respiration testing performed on well MW1-20 is described in section 3.4.

TABLE 3.1
INITIAL SOIL GAS CHEMISTRY
IRP SITE ST-08
FORMER FUEL OIL STORAGE FACILITY
POPE AFB, NORTH CAROLINA

Sample Location	Depth (ft)	O ₂ (%)	CO ₂ (%)	TVH (ppmv) ^{a/}	TPH (mg/kg) ^{b/}	Temp. (°F)
MPA	9.7	4.0	10.8	> 10,000	4,160	NS
MPB	9.2	1.2	15.0	> 10,000	NS	51.3
MPC	9.7	3.8	7.3	> 10,000	NS	NS
MPD	8.7	10.5	9.9	> 10,000	1,290	NS
MPA	4.8	12.2	4.2	3,900	NS	NS
MPB	4.8	15.1	4.6	> 10,000	NS	48.4
MPC	4.7	0.0	12.0	> 10,000	NS	NS
MPD	4.7	18.7	2.5	> 10,000	NS	NS
MP-BG1	6.7	13.2	4.2	44	NS	NS
VW1	8.7 ^{c/}	0.0	12.1	> 10,000	4,120 ^{d/}	NS
VW2	7.1 ^{c/}	0.0	12.4	> 10,000	NS	NS
MW-HF1	10.1 ^{c/}	0.4	11.0	> 10,000	NS	NS
MW-HF2	10.4 ^{c/}	0.0	8.1	19,800	NS	NS

a/ GasTech hydrocarbon analyzer field screening results, parts per million by volume.

b/ Laboratory results, milligrams per kilogram in soil.

c/ Depth shown represents average depth to the center of the exposed, or unsaturated portion, of the well screen.

d/ Soil sample for laboratory analyses collected from 8-10 feet bgs.

NS = Not sampled, analyzed or measured.

Note: Soil gas results for MPC-9.7 and MP-BG1 were obtained on 2/23/95 when these VMPs did not contain water. Soil gas results for all other VMPs and VWs collected on 3/13/95.

3.2 Air Permeability Tests

Two soil air permeability tests were conducted at this site on March 13, 1995 according to protocol procedures. The first test was conducted by injecting air into vent well PO1-VW1. The second test was conducted by injecting air into vent well PO1-VW2. Air injection was accomplished for both tests using a Gast model 1070 rotary vane blower. During both tests, pressure responses were measured at multiple depths in the surrounding VMPs and in the monitoring wells using either a digital manometer or Magnehelic pressure gauges.

3.2.1 Air Permeability Test #1

During the first test, air was injected into PO1-VW1 at an initial flow rate of 12 cubic feet per minute (cfm) and a corresponding VW pressure of 145 inches of water (5.1 psi) with the pressure relief valve fully closed. A moderately high pressure gradient was established between the VW and surrounding VMPs. Pressure responses were observed at all of the monitoring point locations. The pressure responses at several of the VMPs approached steady-state conditions within approximately 10 minutes, while others never achieved or maintained steady-state conditions during the 100 minutes of air injection. These varying soil pressure responses are a function of the soil type at each VMP well screen and the distance from the air injection VW. Soil pressure response data for the first test are summarized in Table 3.2.

Soil gas permeabilities were calculated using both the HyperVentilate^R model (dynamic conditions) and a steady-state pressure equation. Soil permeability (k) values calculated by the HyperVentilate^R model are not as reliable if steady-state conditions are reached too quickly for the model to be valid. For those VMPs where steady-state did not occur too quickly, soil permeability values of 0.28 darcys to 4.3 darcys were obtained by the model. By comparison, the soil permeability (k) value obtained from the steady-state equation was 1.1 darcys. This estimated permeability value is reasonable for a fine sand soil matrix but it is about one order of magnitude higher than expected for a clayey sand. The heterogeneous nature of soils at this site could produce a wide range of permeability values and the calculated steady-state value represents an average of the various soil types.

Air permeability testing at PO1-VW1 produced minor soil pressure response at distances up to 50 feet. Approximate steady-state pressure at PO1-VW2 (r=49.6 feet) was 0.05 inches of water. At PO1-MPA (r=10 feet), approximate steady-state pressures were 24 inches of water (4.8-foot depth) and 67 inches of water (9.7-foot depth). This demonstrates the elevated pressure gradient created in the soils during the test, since the air injection pressure at PO1-VW1 was 5.1 psi (145 inches of water). Parsons ES noted that shallow soils around this VW have a higher moisture and clay content, which will reduce the relative permeability of the soils. Extended air injection is expected to dry the soils and thereby improve their relative permeability.

3.2.2 Air Permeability Test #2

A second air permeability test was conducted at the site to determine if better performance could be achieved at vent well PO1-VW2. The second test began with an air injection flow rate of 13.0 cfm at an initial VW pressure of 100 inches of water (3.6

TABLE 3.2

PRESSURE RESPONSE (inches of water)
 AIR PERMEABILITY TEST #1
 IRP SITE ST-08
 POPE AFB, NORTH CAROLINA

Depth (feet bgs)	MPA		MPB		MPC	VW-2	MPD		MW-HF1
	4.8'	9.7'	4.8'	9.2'	4.7'	7.1' ⁽¹⁾	4.7'	8.7'	10.1' ⁽¹⁾
Elapsed Time (min: sec)									
00:30	0	0	-	0	0	0	0.1	0	0.02
1:00	0	1.0	-	0	0	0	0.2	0	0.02
1:30	0	2.5	0.02	0	-	-	0.22	0	0.02
2:00	0	4.5	0.02	0	0	0	-	-	0.02
2:30	0	8.0	-	-	-	-	0.25	0	0.02
3:00	0	10.5	0.03	0	0	0	-	-	0.02
4:00	0.25	17.5	0.02	0	0	0	-	-	0.03
5:00	0.75	22.0	0.02	0	0	0	-	-	0.04
5:30	1.0	24.0	-	-	-	-	0.3	0	-
6:00	1.0	26.0	0.02	0.01	0	0.02	-	-	0.05
7:00	1.75	29.0	0.02	0.01	0	0.02	-	-	0.06
8:00	2.5	32.0	-	-	0	0.03	0.3	0	0.07
9:00	3.0	35.0	0.02	0.01	0	0.03	-	-	0.08
10:00	3.5	37.5	0.02	0.01	0	0.03	-	-	0.09
11:00	4.0	40.0	-	-	-	-	-	-	-
12:00	4.75	41.5	0.03	0.02	0	0.04	-	-	0.12
13:00	5.25	43.0	-	-	-	-	0.2	0	-
14:00	6.0	44.5	0.03	0.02	0.05	0.05	-	-	0.14
16:00	7.0	46.5	-	-	0.05	0.06	-	-	0.17
18:00	8.0	48.5	0.04	0.05	0.05	0.06	0.2	0	0.19
20:00	9.25	50.0	-	-	0.05	0.07	-	-	0.20
28:00	13.0	57.0	-	-	-	-	-	-	-
30:00	13.5	58.0	0.03	0.06	0.05	0.06	-	-	0.24
35:00	15.3	60.0	-	-	-	-	-	-	-
40:00	17.0	60.5	0.02	0.06	0.05	0.06	0.2	0	0.26
50:00	-	-	0.03	0.08	0.04	0.07	0.21	0	0.28
60:00	20.9	66.0	0.03	0.09	0.03	0.05	0.2	0	0.29
80:00	23.2	66.0	-0.07	0.04	0.03	0.05	0.09	0	0.27
90:00	24.0	67.0	-	-	0.03	0.05	-	-	0.27
100:00	-	-	-0.10	0.05	0.03	0.05	0.05	0	0.27

⁽¹⁾Depth represents center of unsaturated portion of well screen.

psi) with the pressure relief valve fully closed. After 55 minutes of air injection, the back pressure at the VW had dropped to 85 inches of water and the flow rate was unchanged. After 130 minutes of continuous air injection, the VW pressure had reduced to 76 inches of water and the flow rate remained unchanged at 13.0 cfm. Approximate steady-state conditions were achieved at most of the VMPs after about one hour. However, slight pressure changes were occurring in the deeper VMPs after two hours of injection as the soils near the vent well boring dried out and the relative permeability continued to improve.

More uniform pressure responses were obtained in the VMPs during the test on PO1-VW2. A pressure response of 3.1 inches of water was achieved at MW-HF1 ($r=30$ feet) after 130 minutes of injection. At PO1-MPB ($r=24.8$ feet), approximate steady-state pressures were 11.3 inches of water (4.8-foot depth) and 12.4 inches of water (9.2-foot depth). Approximate steady-state pressure at PO1-MPC-4.7 ($r=9.7$ feet) was 17.7 inches of water after 130 minutes. Results of the second air permeability test at Site ST-08 are presented in Table 3.3.

The HyperVentilate[®] model did not produce meaningful soil gas permeabilities for the second test. Test data were evaluated using the steady-state equation and the air injection pressure at the end of the test (VW pressure = 76 inches of water). An air permeability value of 3.1 darcys was derived for approximate steady-state conditions at the end of the test. This value is reasonable for a fine to medium sand soil matrix.

Better air permeability results were achieved at PO1-VW2 than at PO1-VW1. Testing demonstrated that air can be injected into PO1-VW2 at a higher flow rate and lower pressures per foot of well screen than at vent well PO1-VW1. The radius of pressure influence appears to be slightly greater for well PO1-VW2 due to its increased air flow capacity. Pressure responses from both tests indicate that the soil permeabilities vary with depth at most of the VMPs. These apparent soil permeability variations are not uncommon for a heterogeneous soil.

3.3 Oxygen Influence

The depth and radius of oxygen increase in the subsurface resulting from air injection into the VWs during pilot testing is the primary design parameter for full scale bioventing systems. Optimization of full-scale VW systems requires pilot testing to determine the volume of soil that can be oxygenated at a given flow rate and VW screen configuration.

Soil pressure responses measured during the air permeability tests do not necessarily equate to soil gas flow when determining an effective radius of oxygen influence. The ability to actually transport air (oxygen) through the soil column is more important in a bioventing design than the ability to create a pressure response in the soil. Soil gas composition (O_2 , CO_2) was measured at the VMPs during the air permeability tests to monitor the transport of injected air (oxygen) outward from the injection VWs. After 95 minutes of air injection into PO1-VW1 (i.e. test #1), soil gas O_2 had not increased in any of the VMPs and, conversely, O_2 decreased as much as 7 percent in monitoring points MPA and MPB during this time. The O_2 decreases observed at the two VMPs are likely the result of oxygen-deficient soil gas being slowly transported away from the VW. These results indicate that soil gas transport was occurring up to 25 feet from

TABLE 3.3

PRESSURE RESPONSE (inches of water)
 AIR PERMEABILITY TEST #2
 IRP SITE ST-08
 POPE AFB, NORTH CAROLINA

Depth (feet bgs)	MPB		MPC	MPD		MW-HF1
	4.8'	9.2'	4.7'	4.7'	8.7'	10.1' ⁽¹⁾
Elapsed Time (min: sec)						
00:30	0	0.10	4.0	0	0	-
1:00	0.06	0.57	7.0	0	0	0.05
1:30	0.26	1.19	-	0	0	-
2:00	0.58	1.52	9.5	0	0	-
2:30	0.98	2.44	-	-	-	0.50
3:00	1.45	3.04	11.3	-	-	0.54
4:00	2.43	4.12	13.0	-	-	-
5:00	3.37	5.07	13.0	0.2	0.5	-
5:30	-	-	-	-	-	1.55
6:00	4.24	5.84	13.5	-	-	-
7:00	5.04	6.54	14.0	-	-	-
8:00	5.50	7.12	14.5	0.9	-	-
9:00	6.02	7.62	14.6	-	-	-
10:00	6.61	8.07	15.0	1.65	-	2.28
11:00	-	-	-	>2	1.2	-
12:00	7.54	8.78	15.5	>2	1.4	-
13:00	-	-	-	-	-	-
14:00	8.23	9.31	15.5	>2	1.9	2.53
16:00	8.84	9.72	16.0	3.5	2.5	-
18:00	9.31	10.05	16.2	4.25	2.9	-
20:00	9.66	10.30	16.5	5.0	3.3	2.75
22:00	9.95	10.49	16.5	-	-	-
24:00	-	-	-	-	-	2.80
30:00	10.72	10.96	16.75	6.5	5.0	2.85
35:00	11.01	11.12	17.0	7.0	5.6	2.90
40:00	11.17	11.20	17.0	7.1	6.1	2.90
45:00	10.91	11.27	-	7.75	6.5	-
50:00	10.76	11.30	17.1	8.0	6.8	2.95
55:00	10.59	11.32	-	8.0	7.0	-
60:00	10.63	11.34	17.3	8.3	7.3	3.0
130:00	11.27	12.42	17.7	9.3	8.6	3.07

⁽¹⁾Unsaturated screened interval was 7.5' - 12.7' below ground surface at MW-HF1.

the VW, but the air permeability test was not of sufficient duration to see O₂ increases at the VMPs. Long-term air injection is expected to more completely oxygenate the soils surrounding the VWs.

During the second air permeability test, O₂ increased from 0 percent to 6.8 percent in PO1-MPC-4.7 (radius=9.7') after 145 minutes of air injection into vent well PO1-VW2. This was the only VMP that showed an O₂ increase during the short-term air injection and, as observed in the first air permeability test, soil gas O₂ concentrations actually decreased in several of the outlying VMPs. At monitoring point PO1-MPD-8.7 (radius=29.7'), soil gas O₂ decreased from 10.5 percent to 4.0 percent after 2.5 hours of air injection. Again, these short-term decreases in soil gas O₂ concentrations are attributed to outward transport of oxygen-depleted soil gas away from the VW during air injection and they demonstrate that soil gas movement is occurring in these areas. Continued air injection for longer durations is expected to oxygenate these soils. Table 3.4 summarizes the changes in soil gas oxygen concentrations that occurred during the air permeability tests.

3.4 *In Situ* Respiration Tests

An *in situ* respiration test was conducted at both VWs and all four VMPs beginning on March 14, 1995. The deep screened interval of PO1-MPC (9.7') was not included in the testing because it contained water on that date. Respiration testing was conducted in accordance with procedures outlined in the bioventing protocol document referenced in the work plan submitted by Parsons ES. One exception to the work plan and protocol testing procedures was that helium injection into the VMPs was not performed due to underground injection permitting restrictions.

Atmospheric air was injected into the four VMPs for 12.5 hours using either a single 1 cfm rotary vane blower or a larger 4 cfm rotary vane blower with the air flow manifolded to several VMPs. The average air flow rate into each VMP well screen was 0.9 cfm during the 12.5 hours of injection. Air permeability testing from the previous day and direct air injection into the VMPs for 12.5 hours also increased the O₂ concentrations in the adjacent VWs to 10.5 percent (PO1-VW1) and 18.3 percent (PO1-VW2). This allowed *in situ* respiration testing to be conducted at both VWs as well.

Background respiration testing was not conducted at the intended background VMP (PO1-BG1) because the VMP screen was temporarily submerged below the water table, which was elevated due to recent precipitation events. Parsons ES reviewed data from nearby IRP sites and identified several candidate groundwater monitoring wells that could be used as alternate background VMPs. Well MW1-20 at IRP Site FT-01 was selected for background respiration testing because it was located in an area that had site characteristics (i.e. soils and depth-to-groundwater) similar to the former fuel oil storage facility.

Background well MW1-20 was temporarily fitted with air-tight connections and its soil gas was then purged and sampled to obtain representative background readings. Subsurface soils around well MW1-20 contained 18.7% O₂, 2.1% CO₂, and 36 ppmv of TVH at a depth of 9 to 10.3 feet bgs. Assuming the soil geochemistry is similar at both sites, these results indicate that abiotic and/or non-fuel oxygen uptake is probably

TABLE 3.4

INFLUENCE OF AIR INJECTION AT VENT WELLS
ON MONITORING POINT OXYGEN LEVELS
IRP SITE ST-08: FORMER FUEL OIL STORAGE FACILITY
POPE AFB, NORTH CAROLINA

Air Injection Into VW-1 (Test #1)

VMP	Distance From VW-1 (ft)	Depth (ft)	Initial O ₂ (%) ^{a/}	Final O ₂ (%) ^{b/}
MPA	10	9.7	4.0	1.0
MPB	24.8	9.2	1.2	0.9
MPA	10	4.8	12.2	5.0
MPB	24.8	4.8	15.1	14.0

a/ Initial O₂ readings represent baseline conditions prior to the test.

b/ Readings taken at the end of air permeability test after 95 minutes of air injection into VW-1.

Air Injection Into VW-2 (Test #2)

VMP	Distance From VW-2 (ft)	Depth (ft)	Initial O ₂ (%) ^{c/}	Final O ₂ (%) ^{d/}
MPB	24.8	9.2	0.9	1.0
MPD	29.7	8.7	10.5	4.0
MPB	24.8	4.8	14.0	11.5
MPC	9.7	4.7	0	6.8
MPD	29.7	4.7	18.7	NM

c/ Initial O₂ readings represent baseline conditions prior to air permeability test #2 and subsequent to test #1.

d/ Readings taken near the end of air permeability test #2 after 150 minutes of air injection into VW-2.

NM = Not measured

not occurring in soils at the bioventing test site. Nonetheless, air was injected into MW1-20 at a rate of 3 cfm for 1.5 hours in order to conduct a respiration test at this well.

Oxygen uptake and CO₂ production were monitored for 27 hours during the respiration tests at the VMPs. Appendix B contains the field data plots of O₂ utilization obtained during the test. Oxygen was readily utilized by indigenous soil microorganisms, indicating that microbial fuel degradation can be stimulated at this site by oxygen enhancement. Referencing the data plots in Appendix B, the "k" values shown on the graphs are the estimated oxygen utilization rates that are used to calculate fuel biodegradation rates. Oxygen utilization rates ranged from a low of 0.0032 percent per minute at PO1-MPA-4.8 to a high of 0.0125 percent per minute at PO1-MPC-4.7. Five hours of background respiration monitoring at well MW1-20 showed no reduction in the post-injection soil gas O₂ concentration of 20.7 percent. Table 3.5 provides a summary of the oxygen utilization rates for the VMPs and VWs at Site ST-08.

The magnitude of biological oxygen utilization and fuel degradation can be estimated based on the initial pilot test results. Background soil gas conditions at well MW1-20 suggest that abiotic and non-fuel oxygen uptake is probably not a factor at this site. Assuming that no abiotic or non-fuel O₂ uptake occurred during the respiration tests, the observed O₂ utilization rates indicate that between 437 to 1,706 milligrams of hydrocarbons per kilogram of soil can be biodegraded per year at this site. These estimated biodegradation rates are based on an estimated soil porosity of 0.35 percent, an average air-filled volume of 0.068 liters of air per kilogram of soil, and a conservative ratio of 3.5 milligrams of oxygen consumed for every 1 milligram of fuel biodegraded. Actual biodegradation rates can be highly localized and may be affected by soil temperature, soil moisture, fuel (carbon) concentrations, and other factors.

3.5 Potential Air Emissions

No BTEX compounds were detected in any of the soil samples. Additionally, benzene was not detected in any of the soil vapor samples. The highest soil vapor total BTEX concentration was only 86.8 ppmv. These data suggest that potential benzene or BTEX air emissions during bioventing should not be a concern at this site.

While injecting air during the air permeability test, Parsons ES did not detect any hydrocarbon vapors emitted to the atmosphere. Some minor losses of VOCs to the atmosphere are possible during the initiation of bioventing due to the shallow nature of the soil contamination. Potential emissions of VOCs that do occur at system startup should rapidly decrease as accumulated vapors move outward from the injection wells and are biodegraded as they move through the soil.

Initial field testing results suggest that long-term air flow rates into the individual VWs can be slightly less than those used during the air permeability tests, while still maintaining an adequate radius of oxygen influence. The zones of oxygen influence associated with each VW are expected to overlap as both VWs are operated simultaneously. Reduced air injection flow rates will further minimize the potential for fugitive VOC emissions.

TABLE 3.5
APPARENT OXYGEN UTILIZATION RATES
IRP SITE ST-08
FORMER FUEL OIL STORAGE FACILITY
POPE AFB, NORTH CAROLINA

VMP	Test Duration (min)	Apparent O ₂ Utilization (%/min)
MPA-4.8	1,620	0.0032
MPA-9.7	1,630	0.0033
MPB-4.8	1,620	0.0068
MPB-9.2	1,620	0.0104
MPC-4.7	1,610	0.0125
MPD-4.7	1,600	0.0069
MPD-8.7	1,600	0.0123
VW1	1,630	0.0034
VW2	1,280	0.0124
MW1-20 ⁽¹⁾	300	0.0 ⁽²⁾

- (1) Monitoring well MW1-20 was used for background respiration testing.
(2) Background respiration testing showed no apparent oxygen utilization after 5 hours of monitoring.

4.0 RECOMMENDATIONS

Initial testing demonstrated that oxygen has been depleted in the contaminated soils and that aerobic fuel biodegradation can be stimulated at this site by the introduction of oxygen. The Air Force Center for Environmental Excellence (AFCEE) has recommended that extended air injection be initiated at this site to determine the long-term radius of oxygen influence and the effects of time, available nutrients, and changing temperatures on fuel biodegradation rates.

A rotary vane blower will be installed in a small, weatherproof box at the site to provide air injection for an extended pilot study. The blower system will be installed once the airfield construction waiver is approved. As soon as electrical service is established at this site, the blower should be wired and begin operation for an extended test pilot. Adjustments will be made to the system at startup so that pressures into both VWs are somewhat balanced. Initial field testing indicates that vent well PO1-VW2 will perform better than vent well PO1-VW1 at delivering higher air flow rates at less pressure.

Based on oxygen transport observed during the air permeability tests, Parsons ES anticipates that air flows of approximately 8 scfm to 10 scfm into each VW will be sufficient to oxygenate soils at the test site. The relative permeability of the soils should be enhanced over time as the soil moisture content decreases due to continued air injection. The oxygen-delivery radius of influence is expected to exceed 25 feet per VW with air injection rates between 8 scfm to 10 scfm in each VW.

After the system has been operating for approximately seven to eight months, Parsons ES will return to the site to perform a repeat respiration test and to measure the radius of oxygen influence. Final soil samples and soil gas samples will be collected from the site at that time to determine the degree of remediation achieved during the first eight months of *in situ* treatment.

Based on the results of extended pilot-scale bioventing, AFCEE will recommend one of two options for the site:

1. Upgrade the system, if necessary, and continue operation of the bioventing system for full-scale remediation of the site. AFCEE can assist the base in obtaining regulatory approval for upgrading and continued operation.
2. If final soil sampling analytical results indicate significant contaminant removal has occurred, AFCEE may recommend additional sampling to confirm that cleanup criteria have been achieved for this site.

5.0 REFERENCES

- Hinchee, R.E., S.K. Ong., R.N. Miller, D.C. Downey, and R. Frendt. 1992. *Test Plan and Technical Protocol for a Field Treatability Test for Bioventing*. Prepared for the Air Force Center for Environmental Excellence. May. Denver, Colorado.
- Engineering-Science, Inc., 1992. *Field Sampling Plan for AFCEE Bioventing*. Denver, Colorado.

APPENDIX A

SOIL BORING LOGS
AND
WELL CONSTRUCTION RECORDS

NCWELL 05/16/1995 15:17:19

SOIL BORING LOG AND WELL CONSTRUCTION RECORD

Client Pope AFB / AFCEE
 Site ST-08
 Project Identification Number 722407-60040
 Geol./Eng. Supervising Soil Boring S.G. Watkins
 Drilling Method (s) Hollow Stem Auger
 Sampling Method (s) Split Spoon
 Soil Boring Start Date 02/13/95
 Soil Boring Termination Date 02/13/95
 Drilling Company American Environmental Drilling Services
 Borehole Diameter (inches) 8.5
 Borehole Depth (feet below surface) 13.5
 Surface Elevation (feet MSL) na
 Top of Casing Elevation (feet MSL) na

Soil Boring Identification Number P01-VW1
 Well Identification Number P01-VW1
 Geol./Eng. Supervising Well Installation S.G. Watkins
 Casing Installation Date 02/13/95
 Seal Grouting Date 02/13/95
 Casing Material 4" Ø Sch. 40 PVC
 Screen Material 4" Ø 0.020" slot Sch. 40 PVC
 Casing Interval (feet below surface) 1.28 to 5.3
 Screened Interval (feet below surface) 5.3 to 12.2
 Total Well Depth (feet below surface) 12.75
 Water Level Measurement Date na
 Depth to Water (feet below top of casing) na
 Water Level Elevation (feet MSL) na

Comments: Well was installed inside 2' x 2' locking vault.

DEPTH (feet)	Sample	Blows/6 in.	Sample %Rec.	Soil TVH (ppm)	Lithologic Description	Soil Class	Graphic Log	Well Diagram
0.0					Orange-brown (10YR6/2) to gray (5Y5/2) silty SAND (fill).	SM		<p style="font-size: small;">BENTONITE seal CEMENT grout SAND filter pack 4" Ø 0.020" slot Sch. 40 PVC screen 4" Ø Sch. 40 PVC riser</p>
2.0		14,15, 12,8	60	110	Pale yellow-brown (10YR6/2) to light olive-gray (5Y5/2) silty f-m SAND.			
4.0		17,15, 15,14	80	54	Dark yellow-brown (10YR4/2) to olive-gray (5Y4/1) sandy to silty CLAY; wet; stiff; fuel odor.	CL		
6.0		3,3, 4,4	85	120	Yellow-brown (10YR5/4) to olive gray (5Y5/2) silty f-m SAND; trace clay.	ML		
8.0		3,3, 2,2	100	140	Yellow-brown (10YR5/4) to olive gray (5Y5/2) silty to clayey f-m SAND.	SPM C		
10.0		2,2, 3,4	0	na	No recovery on split spoon.			
12.0		2,2, 2,2	100	350	Olive gray (5Y4/1) to light gray (N6) clayey fine SAND; visible free product in soil; saturated.	ML		
14.0					<i>Soil boring and split spoon sampling was terminated at 14.0' below ground surface.</i>			
16.0								
18.0								
20.0								
22.0								
24.0								

GTGS \ 722407 \ P01-VW1.LOG

SOIL BORING LOG AND WELL CONSTRUCTION RECORD

NCWELL 05/16/1995 15:17:24

Client Pope AFB / AFCEE
 Site ST-08
 Project Identification Number 722407-60040
 Geol./Eng. Supervising Soil Boring S.G. Watkins
 Drilling Method (s) Hollow Stem Auger
 Sampling Method (s) Split Spoon
 Soil Boring Start Date 02/13/95
 Soil Boring Termination Date 02/13/95
 Drilling Company American Environmental Drilling Services
 Borehole Diameter (inches) 8.5
 Borehole Depth (feet below surface) 12.55
 Surface Elevation (feet MSL) na
 Top of Casing Elevation (feet MSL) na

Soil Boring Identification Number PO1-VW2
 Well Identification Number PO1-VW2
 Geol./Eng. Supervising Well Installation S.G. Watkins
 Casing Installation Date 02/13/95
 Seal Grouting Date 02/13/95
 Casing Material 4" Ø Sch. 40 PVC
 Screen Material 4" Ø 0.020" slot Sch. 40 PVC
 Casing Interval (feet below surface) 1.08 to 5.1
 Screened Interval (feet below surface) 5.1 to 12
 Total Well Depth (feet below surface) 12.55
 Water Level Measurement Date na
 Depth to Water (feet below of casing) na
 Water Level Elevation (feet MSL) na

Comments: Well was installed inside 2' x 2' locking vault.

DEPTH (feet)	Sample	Blows/6 in.	Sample %Rec.	Soil TVH (ppm)	Lithologic Description	Soil Class	Graphic Log	Well Diagram
0.0					Brown clayey to silty SAND (backfill).	SC		
2.0					Gray (N6) silty f-m SAND; some fuel odor begins at 2.5'.	SM		
4.0					Moderate brown (5YR4/4) to light olive gray (5Y5/2) very silty f-m SAND; stiff; moist.			
6.0					Moderate brown (5YR4/4) to light olive gray (5Y5/2) silty f-m SAND; friable; moist.			
8.0					Moderate brown (5YR4/4) to brown-gray (5YR4/1) silty f-m SAND; trace clay; wet.			
10.0					Olive gray (5Y4/1) to medium gray (N5) silty f-m SAND; trace clay; wet.			
12.0								
14.0					Soil boring was terminated at 12.55' below ground surface. (HSA refusal).			
16.0								
18.0								
20.0								
22.0								
24.0								

GTGS \ 722407 \ PO1-VW2.LOG

SOIL BORING LOG AND WELL CONSTRUCTION RECORD

NCWELL 05/16/1995 15:22:39

Client <u>Pope AFB / AFCEE</u>	Soil Boring Identification Number <u>POI-BG1</u>
Site <u>ST-08</u>	Well Identification Number <u>POI-BG1</u>
Project Identification Number <u>722407-60040</u>	Geol./Eng. Supervising Well Installation <u>S.G. Watkins</u>
Geol./Eng. Supervising Soil Boring <u>S.G. Watkins</u>	Casing Installation Date <u>02/14/95</u>
Drilling Method (s) <u>Hand Auger</u>	Seal Grouting Date <u>02/14/95</u>
Sampling Method (s) <u>Hand Auger</u>	Casing Material <u>0.5" Ø Sch. 80 PVC</u>
Soil Boring Start Date <u>02/14/95</u>	Screen Material <u>0.5" Ø 0.020" slot Sch. 80 PVC</u>
Soil Boring Termination Date <u>02/14/95</u>	Casing Interval (feet below surface) <u>.33 to 6.2</u>
Drilling Company <u>American Environmental Drilling Services</u>	Screened Interval (feet below surface) <u>6.2 to 6.7</u>
Borehole Diameter (inches) <u>4</u>	Borehole Depth (feet below surface) <u>6.9</u>

Comments: Well was installed inside 12" diameter bolted manhole.

DEPTH (feet)	Sample	Blows/6 in.	Sample %Rec.	Soil TVH (ppm)	Lithologic Description	Soil Class	Graphic Log	Well Diagram
0.0					Dark gray-brown silty f-m SAND (top soil).	SM		
					Orange/light brown silty f-m SAND.			
2.0	X	na	na	17	Light gray silty f-m SAND.			
					Light gray to very pale brown sandy CLAY to clayey fine SAND; no fuel odor.	ML		
4.0	X	na	na	14				
6.0	X	na	na	12	Very pale gray silty f-m SAND; trace clay.	SM		
8.0					Very pale gray (N7) to very pale yellow-gray (5Y7/2) medium SAND; well sorted; trace silt; moist; no fuel odor.	SP		
					Soil boring was terminated at 6.9' below ground surface.			
10.0								
12.0								
14.0								
16.0								
18.0								
20.0								
22.0								
24.0								

GTGS \ 722407 \ POI-BG1.LOG

NCWELL 05/16/1995 15:22:44

SOIL BORING LOG AND WELL CONSTRUCTION RECORD

Client Pope AFB / AFCEE
 Site ST-08
 Project Identification Number 722407-60040
 Geol./Eng. Supervising Soil Boring S.G. Watkins
 Drilling Method (s) Hand Auger
 Sampling Method (s) Hand Auger
 Soil Boring Start Date 02/13/95
 Soil Boring Termination Date 02/13/95
 Drilling Company American Environmental Drilling Services
 Borehole Diameter (inches) 4
 Borehole Depth (feet below surface) 10
 Deep Casing Installation Date 02/13/95
 Deep Seal Grouting Date 02/13/95

Soil Boring Identification Number PO1-MPA
 Well Identification Number PO1-MPA
 Geol./Eng. Supervising Well Installation S.G. Watkins
 Shallow Casing Installation Date 02/13/95
 Shallow Seal Grouting Date 02/13/95
 Deep Casing Material 0.5" Ø Sch. 80 PVC
 Deep Screen Material 0.5" Ø 0.020" slot Sch. 80 PVC
 Shallow Casing Material 0.5" Ø Sch. 80 PVC
 Shallow Screen Material 0.5" Ø 0.020" slot Sch. 80 PVC
 D. Casing Interval (feet below surface) .33 to 9.2
 D. Screen Interval (feet below surface) 9.2 to 9.7
 S. Casing Interval (feet below surface) .33 to 4.3
 S. Screen Interval (feet below surface) 4.3 to 4.8

Comments: Well was installed inside 12" diameter bolted manhole.

DEPTH (feet)	Sample	Blows/6 in.	Sample %Rec.	Soil TVH (ppm)	Lithologic Description	Soil Class	Graphic Log	Well Diagram
0.0					Moderate brown silty medium SAND (fill).	SM		
2.0	na	na	200	Lt. olive gray (5Y6/1) to pale yellow-brown (10YR6/2) f-m SAND; trace silt; moist.	SP			
4.0	na	na	230	Light olive gray (5Y6/1) to light brown (5YR5/6) f-m SAND; trace silt; moist.				
4.0	na	na	200	Light olive gray (5Y6/1) silty fine SAND; moist to wet; slight fuel odor.	SM			
6.0	na	na	220	Pale yel.-brn. (10YR6/2) to lt.ol.-gry. (5Y6/1) silty f-m SAND; crumbly; moist; sl.fuel odor.				
8.0	na	na	110	Pale yel.-brn. (10YR6/2) to lt.ol.-gry. (5Y6/1) silty f-m SAND; crumbly; moist; sl.fuel odor.				
10.0	na	na	300	Pale yel.-brn. (10YR6/2) to lt.ol.-gry. (5Y6/1) clayey fine SAND; crumbly; moist; fuel odor.				
10.0					<i>Soil boring was terminated at 10.0' below ground surface.</i>			
12.0								
14.0								
16.0								
18.0								
20.0								
22.0								
24.0								

GTGS \ 722407 \ PO1-MPA.LOG

SOIL BORING LOG AND WELL CONSTRUCTION RECORD

Client Pope AFB / AFCEE
 Site ST-08
 Project Identification Number 722407-60040
 Geol./Eng. Supervising Soil Boring S.G. Watkins
 Drilling Method (s) Hand Auger
 Sampling Method (s) Hand Auger
 Soil Boring Start Date 02/13/95
 Soil Boring Termination Date 02/13/95
 Drilling Company American Environmental Drilling Services
 Borehole Diameter (inches) 4
 Borehole Depth (feet below surface) 9.4
 Deep Casing Installation Date 02/13/95
 Deep Seal Grouting Date 02/13/95

Soil Boring Identification Number POI-MPB
 Well Identification Number POI-MPB
 Geol./Eng. Supervising Well Installation S.G. Watkins
 Shallow Casing Installation Date 02/13/95
 Shallow Seal Grouting Date 02/13/95
 Deep Casing Material 0.5" Ø Sch. 80 PVC
 Deep Screen Material 0.5" Ø 0.020" slot Sch. 80 PVC
 Shallow Casing Material 0.5" Ø Sch. 80 PVC
 Shallow Screen Material 0.5" Ø 0.020" slot Sch. 80 PVC
 D. Casing Interval (feet below surface) .33 to 8.7
 D. Screen Interval (feet below surface) 8.7 to 9.2
 S. Casing Interval (feet below surface) .33 to 4.3
 S. Screen Interval (feet below surface) 4.3 to 4.8

Comments: Well was installed inside 12" diameter bolted manhole.

DEPTH (feet)	Sample	Blows/6 in.	Sample %Rec.	Soil TVH (ppm)	Lithologic Description	Soil Class	Graphic Log	Well Diagram
0.0					Orange-brown silty f-m SAND (fill).	SM		<p style="font-size: small;"> BENTONITE SAND CEMENT 0.5" Ø PVC riser 0.5" Ø 0.020" slot PVC screen 0.5" Ø 0.020" slot PVC screen </p>
2.0								
4.0	X	na	na	78	Pale yellow-brown (10YR6/2) slightly silty f-m SAND; moist.			
4.0	X	na	na	170	Moderate brown (5YR4/4) to light olive gray (5Y5/2) silty fine SAND; moist; fuel odor.			
6.0	X	na	na	120	Light olive-gray (5Y5/2) to moderate brown (5YR4/4) silty f-m SAND with streaks of clayey SAND and CLAY; fuel odor.	SC		
8.0	X	na	na	140	Light olive-gray (5Y5/2) to moderate brown (5YR4/4) clayey f-m SAND; fuel odor.	ML		
10.0					Soil boring was terminated at 9.4' below ground surface.			
12.0								
14.0								
16.0								
18.0								
20.0								
22.0								
24.0								

SOIL BORING LOG AND WELL CONSTRUCTION RECORD

Client Pope AFB / AFCEE
 Site ST-08
 Project Identification Number 722407-60040
 Geol./Eng. Supervising Soil Boring S.G. Watkins
 Drilling Method (s) Hollow Stem Auger
 Sampling Method (s) Split Spoon
 Soil Boring Start Date 02/13/95
 Soil Boring Termination Date 02/13/95
 Drilling Company American Environmental Drilling Services
 Borehole Diameter (inches) 8.5
 Borehole Depth (feet below surface) 9.9
 Deep Casing Installation Date 02/13/95
 Deep Seal Grouting Date 02/13/95

Soil Boring Identification Number POI-MPC
 Well Identification Number POI-MPC
 Geol./Eng. Supervising Well Installation S.G. Watkins
 Shallow Casing Installation Date 02/13/95
 Shallow Seal Grouting Date 02/13/95
 Deep Casing Material 0.5" Ø Sch. 80 PVC
 Deep Screen Material 0.5" Ø 0.020" slot Sch. 80 PVC
 Shallow Casing Material 0.5" Ø Sch. 80 PVC
 Shallow Screen Material 0.5" Ø 0.020" slot Sch. 80 PVC
 D. Casing Interval (feet below surface) .33 to 9.2
 D. Screen Interval (feet below surface) 9.2 to 9.7
 S. Casing Interval (feet below surface) .33 to 4.2
 S. Screen Interval (feet below surface) 4.2 to 4.7

Comments: Well was installed inside 12" diameter bolted manhole.

DEPTH (feet)	Sample	Blows/6 in.	Sample %Rec.	Soil TVH (ppm)	Lithologic Description	Soil Class	Graphic Log	Well Diagram
0.0					Orange-brown to gray silty f-m SAND (fill); moist.	SM		
2.0				Brown to gray fine SAND; trace silt; moist; fuel odor below 3'.				
4.0	X	2,4, 4,5	100	110	Pale yellow-brown (10YR6/2) to light olive gray (5Y5/2) silty f-m SAND; fuel odor.			
6.0	X	5,2, 3,4	90	74	Light olive gray (5Y5/2) clayey f-m SAND; moist; slight fuel odor.	ML		
8.0	X	3,2, 3,3	100	160	Pale yellow-brown (10YR6/2) to light olive gray (5Y5/2) clayey to silty f-m SAND; stiff; wet; fuel odor.	SM CL		
10.0					Soil boring was terminated at 9.9' below ground surface.			
12.0								
14.0								
16.0								
18.0								
20.0								
22.0								
24.0								

NCWELL 05/16/1995 15:22:52
 GTGS \ 722407 \ POI-MPC.LOG

SOIL BORING LOG AND WELL CONSTRUCTION RECORD

NCWELL 05/16/1995 15:22:56

Client Pope AFB / AFCEE
 Site ST-08
 Project Identification Number 722407-60040
 Geol./Eng. Supervising Soil Boring S.G. Watkins
 Drilling Method (s) Hand Auger
 Sampling Method (s) Hand Auger
 Soil Boring Start Date 02/13/95
 Soil Boring Termination Date 02/13/95
 Drilling Company American Environmental Drilling Services
 Borehole Diameter (inches) 4
 Borehole Depth (feet below surface) 9
 Deep Casing Installation Date 02/13/95
 Deep Seal Grouting Date 02/13/95

Soil Boring Identification Number POI-MPD
 Well Identification Number POI-MPD
 Geol./Eng. Supervising Well Installation S.G. Watkins
 Shallow Casing Installation Date 02/13/95
 Shallow Seal Grouting Date 02/13/95
 Deep Casing Material 0.5" Ø Sch. 80 PVC
 Deep Screen Material 0.5" Ø 0.020" slot Sch. 80 PVC
 Shallow Casing Material 0.5" Ø Sch. 80 PVC
 Shallow Screen Material 0.5" Ø 0.020" slot Sch. 80 PVC
 D. Casing Interval (feet below surface) .33 to 8.2
 D. Screen Interval (feet below surface) 8.2 to 8.7
 S. Casing Interval (feet below surface) .33 to 4.2
 S. Screen Interval (feet below surface) 4.2 to 4.7

Comments: Well was installed inside 12" diameter bolted manhole.

DEPTH (feet)	Sample	Blows/6 in.	Sample %Rec.	Soil TVH (ppm)	Lithologic Description	Soil Class	Graphic Log	Well Diagram
0.0						SW		
2.0	X	na	na	85	Light olive gray (5Y5/2) slightly silty f-m SAND; crumbly; moist; strong fuel odor.			
4.0	X	na	na	130	Lt. olive gray (5Y5/2) slightly silty f-m SAND with mod. yellow-brown (10YR5/4) mottles; crumbly; moist; strong fuel odor.			
6.0	X	na	na	140	Lt. olive gray (5Y5/2) slightly silty f-m SAND with mod. yellow-brown (10YR5/4) mottles; more silt; crumbly; moist; fuel odor.	SM		
8.0	X	na	na	220	Pale yellow-brown (10YR6/2) to light olive gray (5Y5/2) silty to clayey f-m SAND; moist to wet; fuel odor.	SC		
10.0					Soil boring was terminated at 9.0' below ground surface.			
12.0								
14.0								
16.0								
18.0								
20.0								
22.0								
24.0								

GTGS \ 722407 \ POI-MPD.LOG

APPENDIX B

OXYGEN UTILIZATION DATA PLOTS

Initial Respiration Test
ST-08
Pope AFB, North Carolina

Monitoring Point	Date	Days Elapsed (frac. days)	Time	Hrs elapsed (fractional days)	Days Elapsed	Elapsed Time (min. x 1000)	O2% CO2	Total Hydrocarbon	Comments	Trend of O2/ Time	New x-values	k
P01-MPA-4.8	03/14/95	0.00	12:00	0.02	0.02	0.03	11.0	4.1	350	11.1772263	0	0.003193
P01-MPA-4.8	03/14/95	0.00	12:48	0.05	0.05	0.08	11.2	3.8	NM	6.00479144	1.62	
P01-MPA-4.8	03/14/95	0.00	14:35	0.13	0.13	0.19	9.8	3.8	560			
P01-MPA-4.8	03/14/95	0.00	16:35	0.21	0.21	0.31	10.8	2.8	330			
P01-MPA-4.8	03/14/95	0.00	18:30	0.29	0.29	0.42	10.0	3.2	370			
P01-MPA-4.8	03/14/95	0.00	20:30	0.38	0.38	0.54	9.1	3.2	360			
P01-MPA-4.8	03/15/95	1.00	08:45	-0.11	0.89	1.28	7.8	3.5	540			
P01-MPA-4.8	03/15/95	1.00	14:30	0.13	1.13	1.62	5.5	3.8	560			
P01-MPA-9.7	03/14/95	0.00	12:00	0.02	0.02	0.03	12.8	1.9	220	11.5910518	0	0.003310
P01-MPA-9.7	03/14/95	0.00	12:45	0.05	0.05	0.08	11.2	3.1	NM	6.19589206	1.63	
P01-MPA-9.7	03/14/95	0.00	14:40	0.13	0.13	0.19	10.6	3.2	730			
P01-MPA-9.7	03/14/95	0.00	16:45	0.22	0.22	0.32	10.2	3.2	700			
P01-MPA-9.7	03/14/95	0.00	18:35	0.30	0.30	0.43	9.9	3.8	700			
P01-MPA-9.7	03/14/95	0.00	20:35	0.38	0.38	0.55	9.4	3.6	750			
P01-MPA-9.7	03/15/95	1.00	08:45	-0.11	0.89	1.28	7.0	4.5	>10,000			
P01-MPA-9.7	03/15/95	1.00	14:35	0.13	1.13	1.63	6.8	4.5	>10,000			
P01-MPB-4.8	03/14/95	0.00	11:55	0.02	0.02	0.02	19.1	0.8	110	Temp. = 50.1 ° F	0	0.006835
P01-MPB-4.8	03/14/95	0.00	12:50	0.06	0.06	0.08	17.0	0.8	NM	Temp. = 49.7 ° F	1.62	
P01-MPB-4.8	03/14/95	0.00	14:45	0.14	0.14	0.20	14.8	1.0	320	Temp. = 49.5 ° F		
P01-MPB-4.8	03/14/95	0.00	16:50	0.22	0.22	0.32	12.4	1.3	270	Temp. = 49.5 ° F		
P01-MPB-4.8	03/14/95	0.00	18:25	0.29	0.29	0.42	11.5	1.5	270			
P01-MPB-4.8	03/14/95	0.00	20:25	0.37	0.37	0.54	10.2	1.6	300	Temp. = 49.6 ° F		
P01-MPB-4.8	03/15/95	1.00	08:35	-0.12	0.88	1.27	7.3	2.5	510	Temp. = 49.9 ° F		
P01-MPB-4.8	03/15/95	1.00	14:25	0.12	1.12	1.62	6.8	2.8	560			
P01-MPB-9.2	03/14/95	0.00	11:50	0.01	0.01	0.02	19.3	0.6	120	Temp. = 51.5 ° F	0	0.010408
P01-MPB-9.2	03/14/95	0.00	12:50	0.06	0.06	0.08	16.2	0.8	NM	Temp. = 51.5 ° F	1.62	
P01-MPB-9.2	03/14/95	0.00	14:45	0.14	0.14	0.20	12.3	0.9	340	Temp. = 53.2 ° F		
P01-MPB-9.2	03/14/95	0.00	16:50	0.22	0.22	0.32	9.7	1.0	320	Temp. = 51.6 ° F		
P01-MPB-9.2	03/14/95	0.00	18:30	0.29	0.29	0.42	8.7	1.3	320			
P01-MPB-9.2	03/14/95	0.00	20:30	0.38	0.38	0.54	7.0	1.7	380	Temp. = 51.5 ° F		
P01-MPB-9.2	03/15/95	1.00	08:40	-0.12	0.88	1.27	1.3	2.8	6,900	Temp. = 51.8 ° F		
P01-MPB-9.2	03/15/95	1.00	14:30	0.13	1.13	1.62	0.7	3.5	8,300			

P01-MPC-4.7	03/14/95	0.00	11:57	0.02	0.02	0.03	20.5	0.4	41	18.969017	0	0.012465
P01-MPC-4.7	03/14/95	0.00	12:48	0.05	0.05	0.08	19.8	0.3	NM	-1.0391334	1.61	
P01-MPC-4.7	03/14/95	0.00	14:45	0.14	0.14	0.20	17.6	0.7	160			
P01-MPC-4.7	03/14/95	0.00	16:00	0.19	0.19	0.27	15.5	0.7	260			
P01-MPC-4.7	03/14/95	0.00	16:40	0.22	0.22	0.31	14.0	0.7	210			
P01-MPC-4.7	03/14/95	0.00	18:21	0.29	0.29	0.41	11.7	1.1	240			
P01-MPC-4.7	03/14/95	0.00	20:30	0.38	0.38	0.54	9.6	1.1	220			
P01-MPC-4.7	03/15/95	1.00	08:45	-0.11	0.89	1.28	2.3	3.0	410			
P01-MPC-4.7	03/15/95	1.00	14:15	0.11	1.11	1.61	1.0	4.0	5,700			
P01-MPD-4.7	03/14/95	0.00	11:53	0.02	0.02	0.02	13.5	3.8	150	12.7509676	0	0.006859
P01-MPD-4.7	03/14/95	0.00	12:43	0.05	0.05	0.07	11.2	3.5	NM	1.77728643	1.6	
P01-MPD-4.7	03/14/95	0.00	14:40	0.13	0.13	0.19	11.0	3.5	260			
P01-MPD-4.7	03/14/95	0.00	15:57	0.19	0.19	0.27	12.8	3.3	340			
P01-MPD-4.7	03/14/95	0.00	16:35	0.21	0.21	0.31	10.0	3.2	390			
P01-MPD-4.7	03/14/95	0.00	18:15	0.28	0.28	0.41	11.0	4.5	240			
P01-MPD-4.7	03/14/95	0.00	20:25	0.37	0.37	0.54	7.0	5.0	240			
P01-MPD-4.7	03/15/95	1.00	08:35	-0.12	0.88	1.27	4.5	3.5	290			
P01-MPD-4.7	03/15/95	1.00	14:10	0.11	1.11	1.60	9.0	4.5	240			
P01-MPD-8.7	03/14/95	0.00	11:55	0.02	0.02	0.02	19.2	0.5	115	17.3532097	0	0.012290
P01-MPD-8.7	03/14/95	0.00	12:46	0.05	0.05	0.08	16.8	0.6	NM	-2.3110061	1.6	
P01-MPD-8.7	03/14/95	0.00	14:43	0.13	0.13	0.19	14.0	0.9	270			
P01-MPD-8.7	03/14/95	0.00	16:00	0.19	0.19	0.27	14.0	0.9	400			
P01-MPD-8.7	03/14/95	0.00	16:40	0.22	0.22	0.31	13.0	1.2	340			
P01-MPD-8.7	03/14/95	0.00	18:20	0.28	0.28	0.41	12.0	1.7	360			
P01-MPD-8.7	03/14/95	0.00	20:30	0.38	0.38	0.54	9.0	1.7	360			
P01-MPD-8.7	03/15/95	1.00	08:40	-0.12	0.88	1.27	2.8	2.8	530			
P01-MPD-8.7	03/15/95	1.00	14:10	0.11	1.11	1.60	5.0	2.5	600			
P01-VWV1	03/14/95	0.00	12:25	0.04	0.04	0.05	10.5	6.9	990	5.89557314	0	0.003367
P01-VWV1	03/14/95	0.00	12:55	0.06	0.06	0.08	8.0	7.8	NM	0.4071182	1.63	
P01-VWV1	03/14/95	0.00	14:55	0.14	0.14	0.21	5.9	8.1	1,400			
P01-VWV1	03/14/95	0.00	16:55	0.23	0.23	0.33	3.9	8.2	>10,000			
P01-VWV1	03/14/95	0.00	18:40	0.30	0.30	0.43	3.0	8.4	NM			
P01-VWV1	03/14/95	0.00	20:40	0.38	0.38	0.55	2.4	8.5	NM			
P01-VWV1	03/15/95	1.00	08:50	-0.11	0.89	1.28	1.6	8.2	9,200			
P01-VWV1	03/15/95	1.00	14:40	0.13	1.13	1.63	1.3	8.1	>10,000			
P01-VWV2	03/14/95	0.00	11:58	0.02	0.02	0.03	18.3	2.1	380	16.8490656	0	0.012361
P01-VWV2	03/14/95	0.00	12:50	0.06	0.06	0.08	17.0	2.2	NM	1.02667717	1.28	
P01-VWV2	03/14/95	0.00	14:50	0.14	0.14	0.20	15.2	2.6	440			
P01-VWV2	03/14/95	0.00	16:05	0.19	0.19	0.28	13.6	2.8	450			
P01-VWV2	03/14/95	0.00	16:45	0.22	0.22	0.32	12.4	2.9	360			
P01-VWV2	03/14/95	0.00	18:25	0.29	0.29	0.42	10.5	3.3	360			
P01-VWV2	03/14/95	0.00	20:35	0.38	0.38	0.55	9.0	3.5	360			
P01-VWV2	03/15/95	1.00	08:50	-0.11	0.89	1.28	1.8	4.2	420			

INITIAL RESPIRATION TEST
MONITORING POINT MPA-4.8
ST-08
POPE AFB, NC

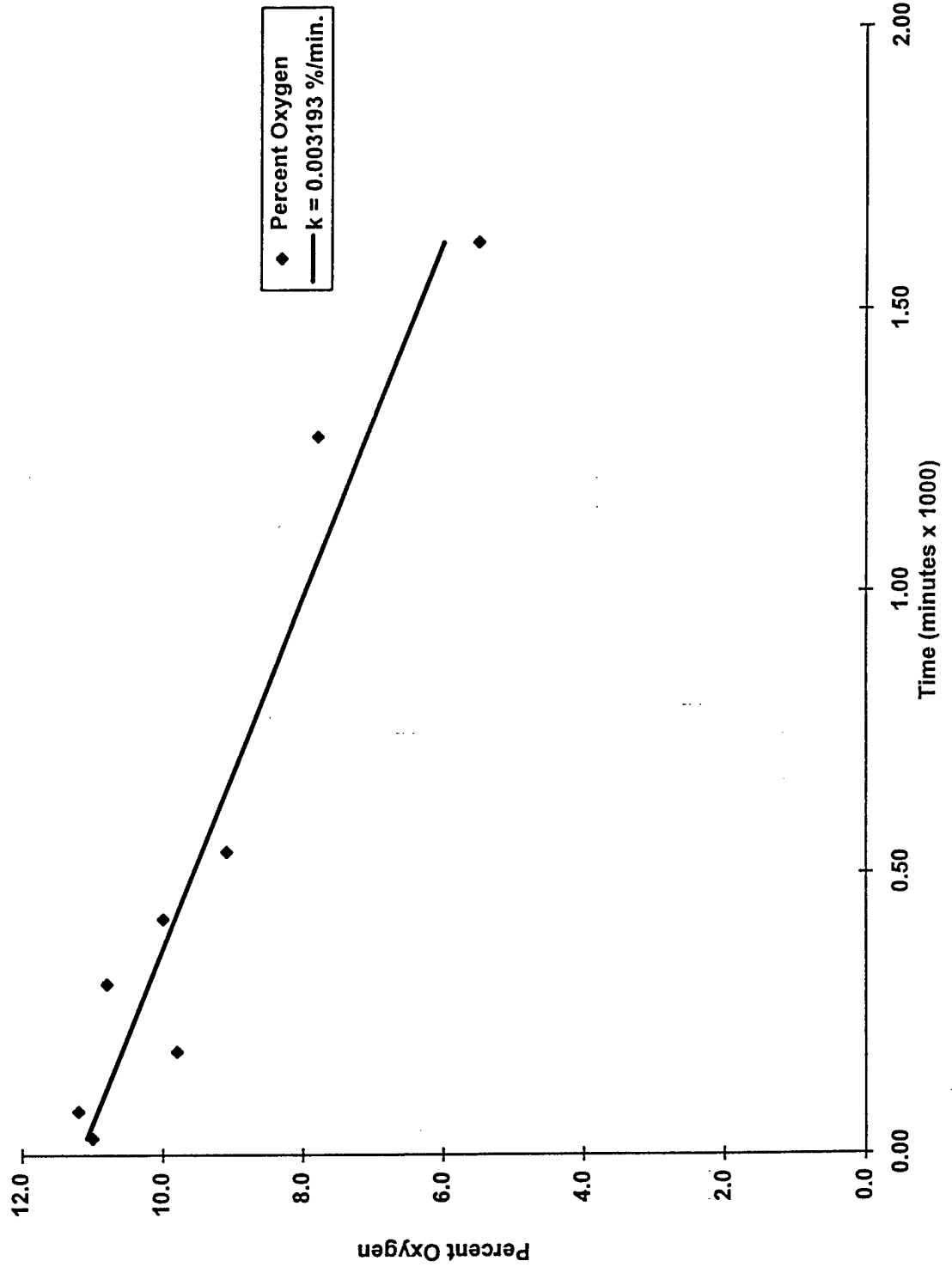

INITIAL RESPIRATION TEST
MONITORING POINT MPA-9.7
ST-08
POPE AFB, NC

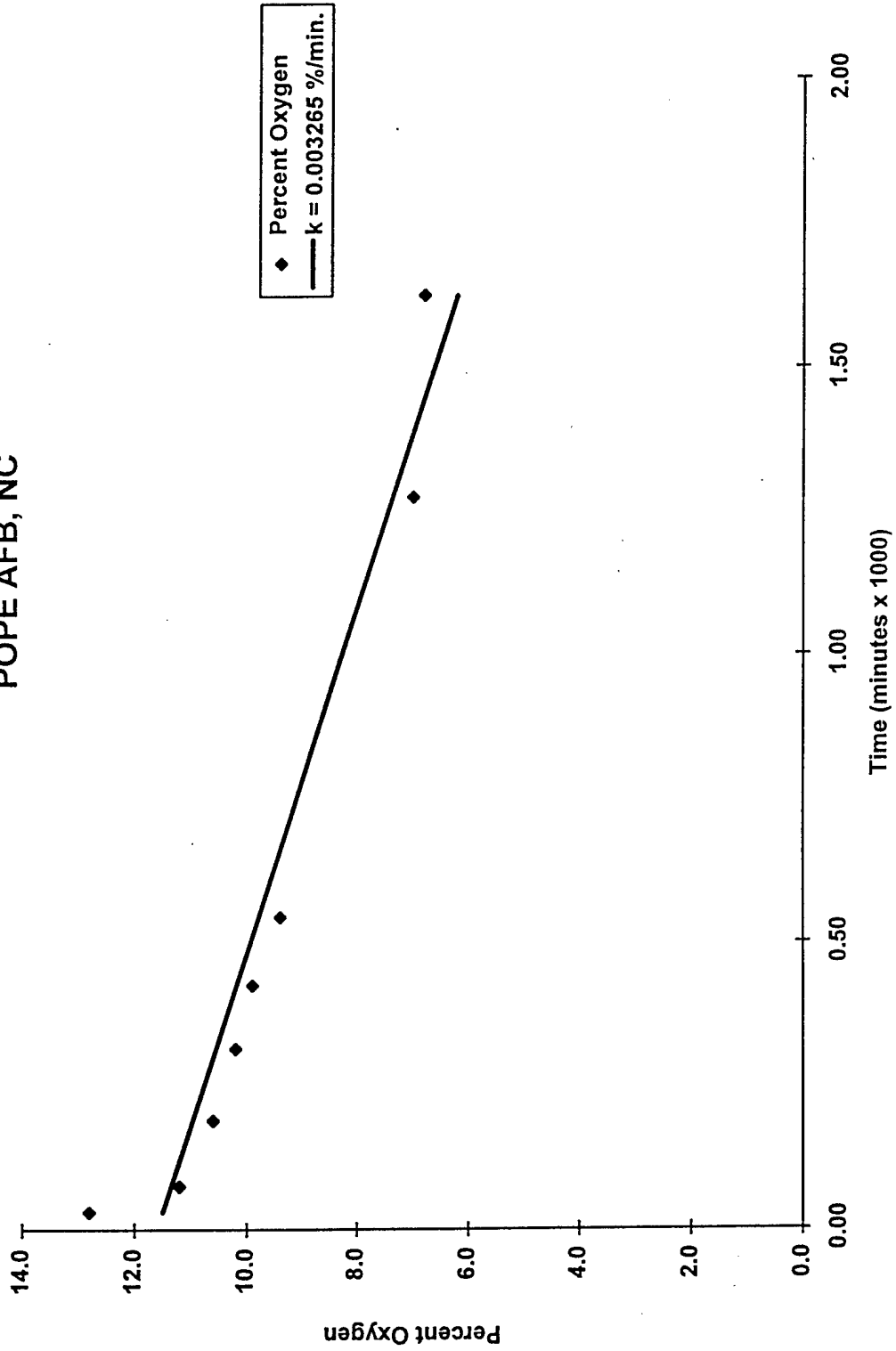

INITIAL RESPIRATION TEST
MONITORING POINT MPB-4.8
ST-08
POPE AFB, NC

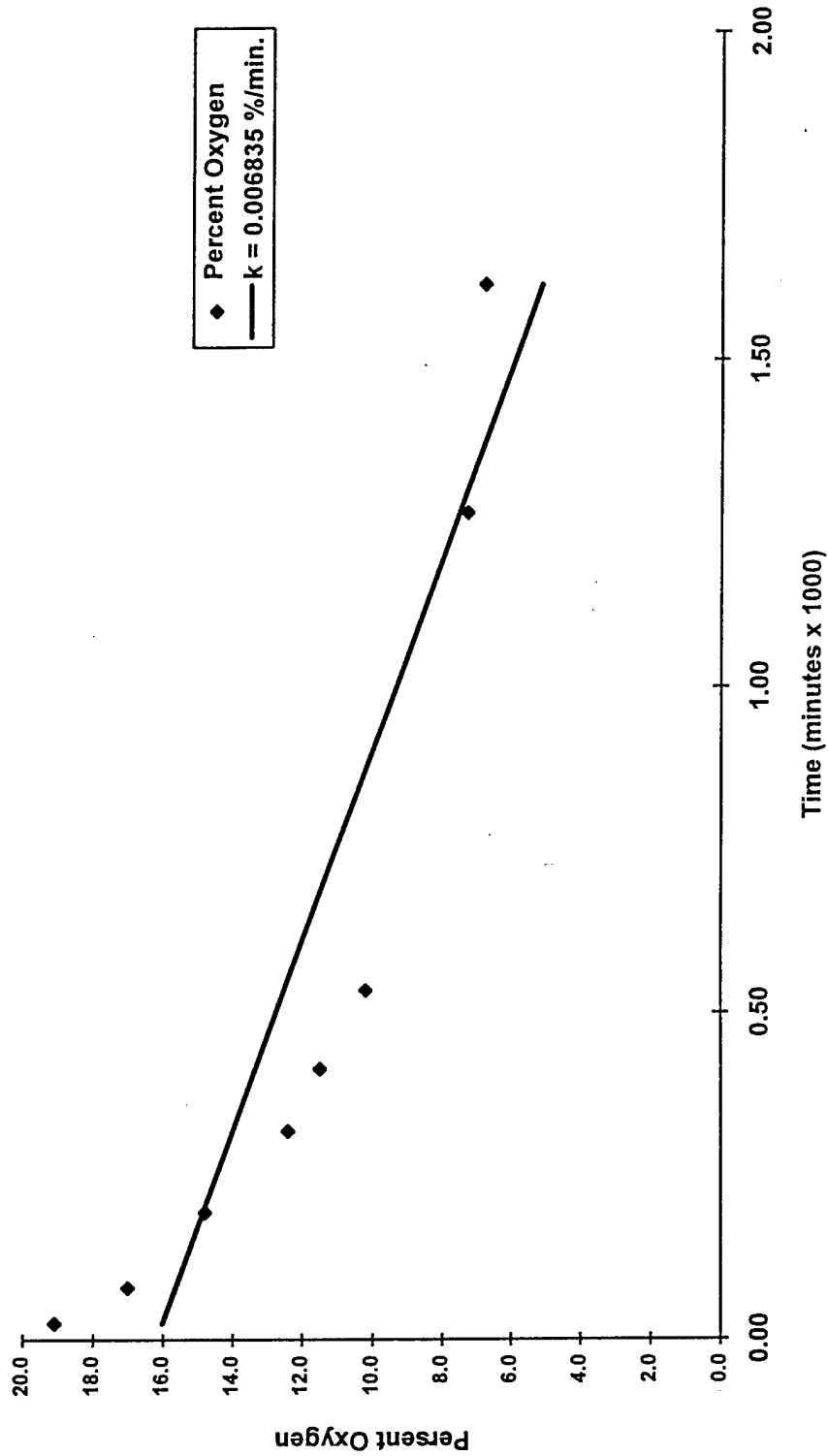

INITIAL RESPIRATION TEST
MONITORING POINT MPB-9.2
ST-08
POPE AFB, NC

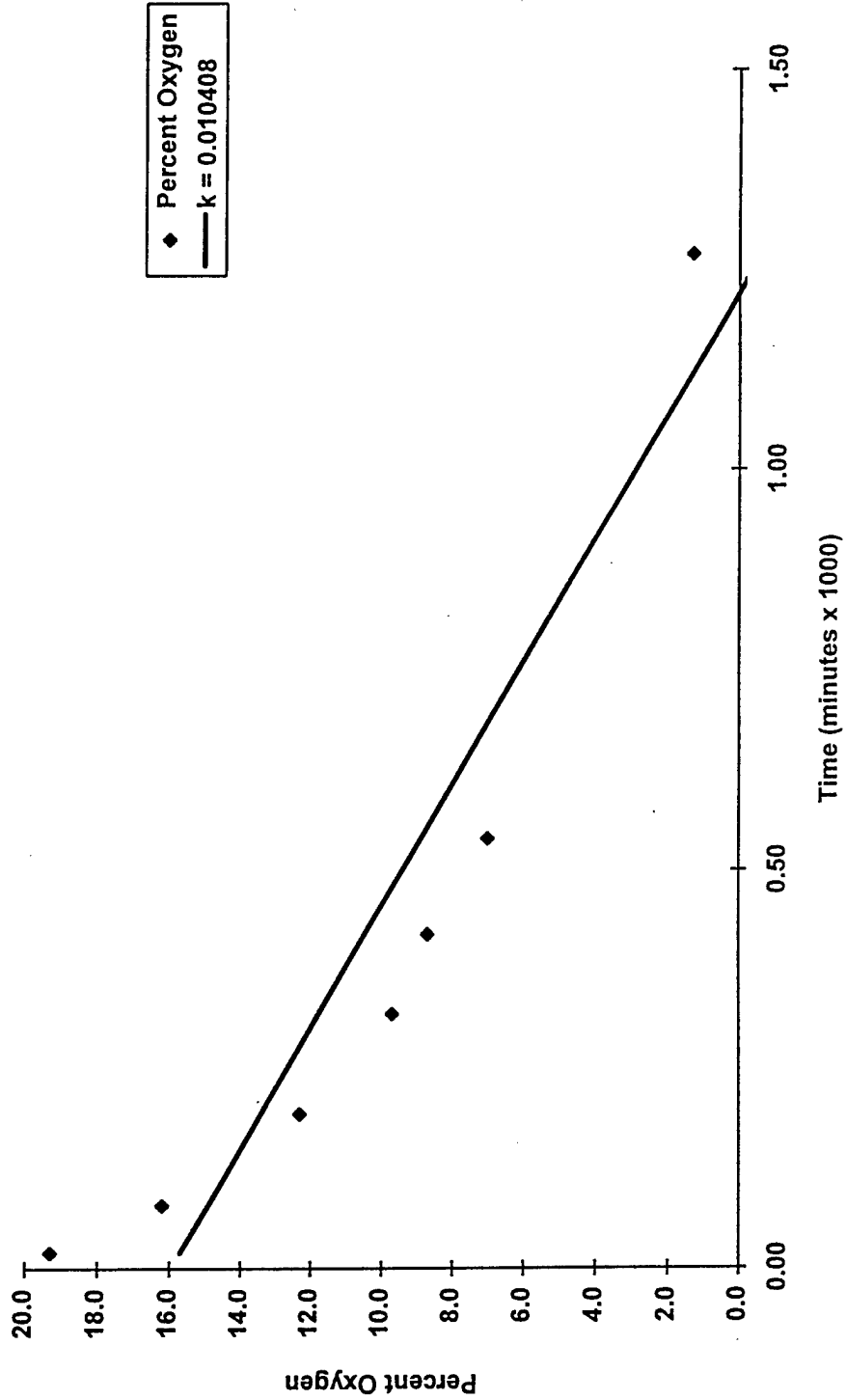

INITIAL RESPIRATION TEST
MONITORING POINT MPC-4.7
ST-08
POPE AFB, NC

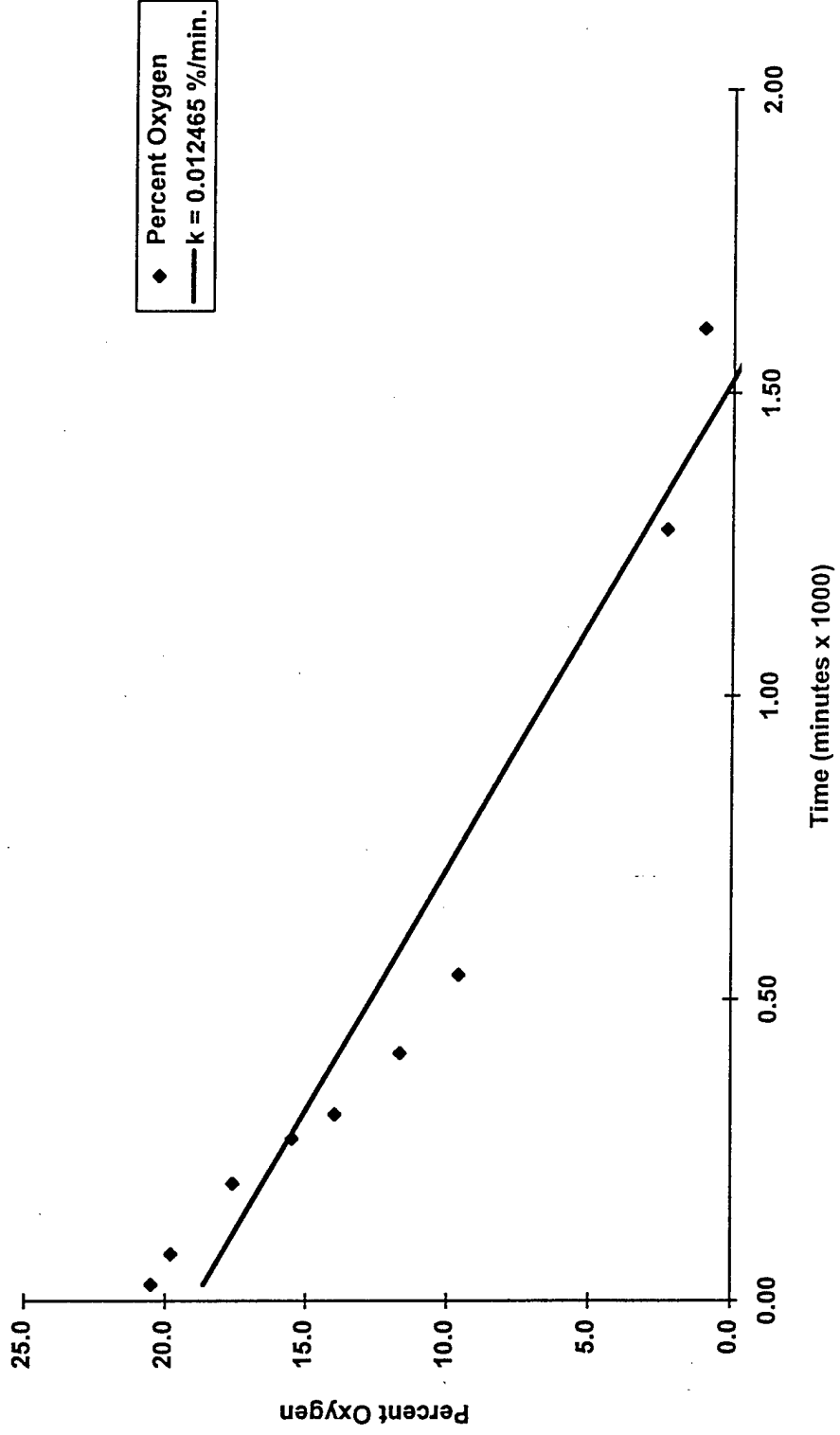

INITIAL RESPIRATION TEST
MONITORING POINT MPD-4.7

ST-08

POPE AFB, NC

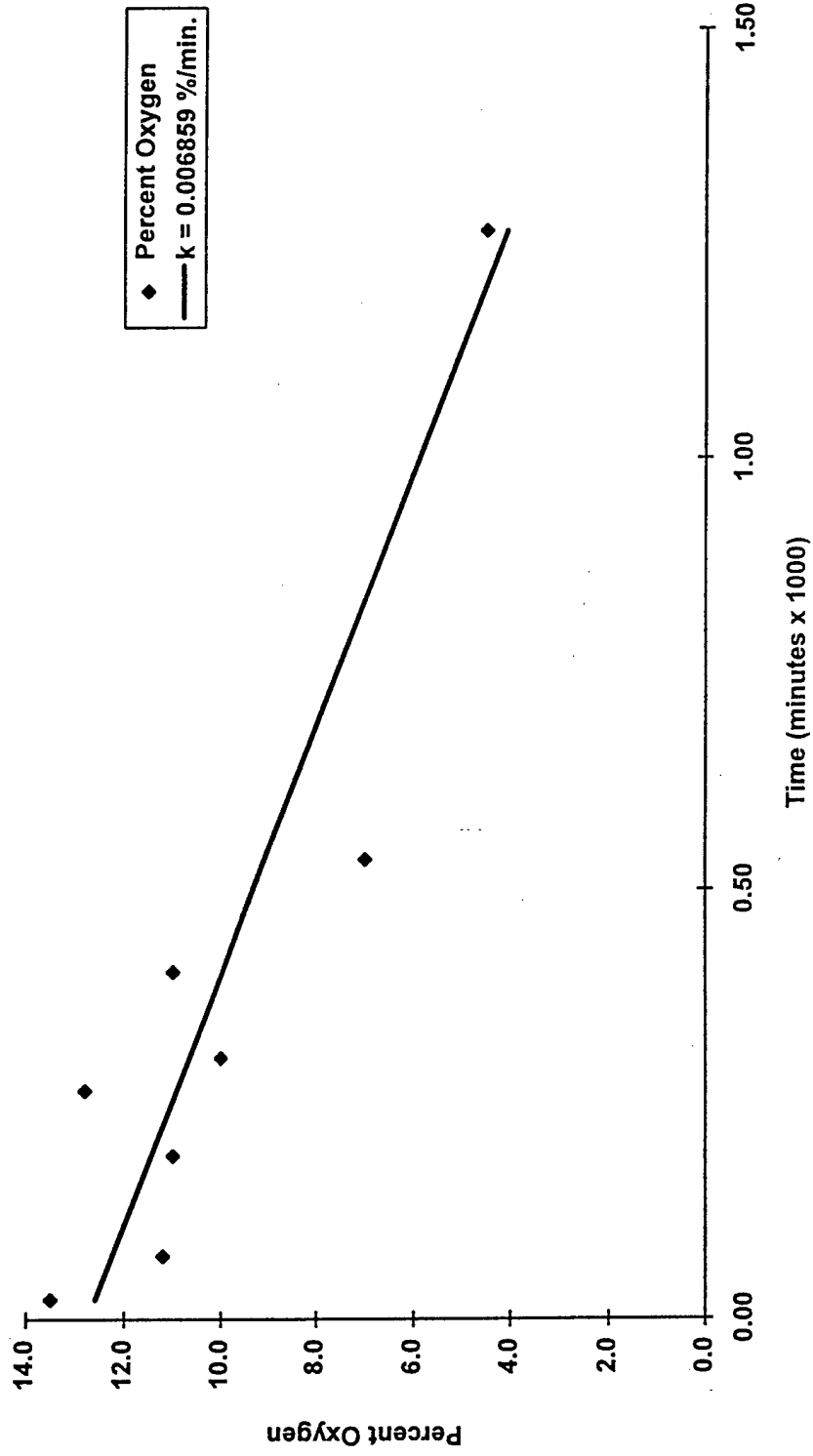

INITIAL RESPIRATOR TEST
MONITORING POINT MPD-8.7
ST-08
POPE AFB, NC

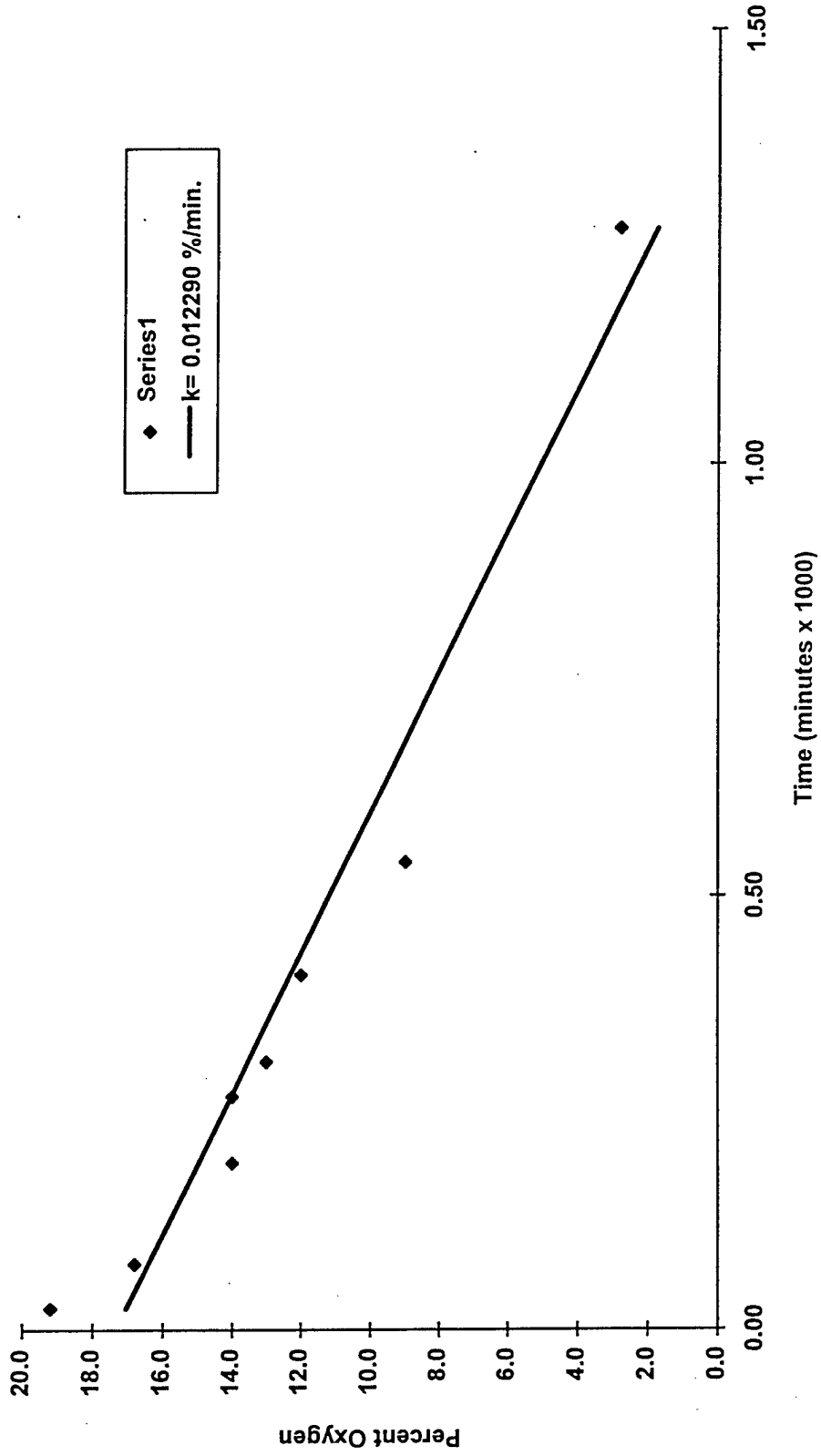

INITIAL RESPIRATION TEST
MONITORING POINT VW1
ST-08
POPE AFB, NC

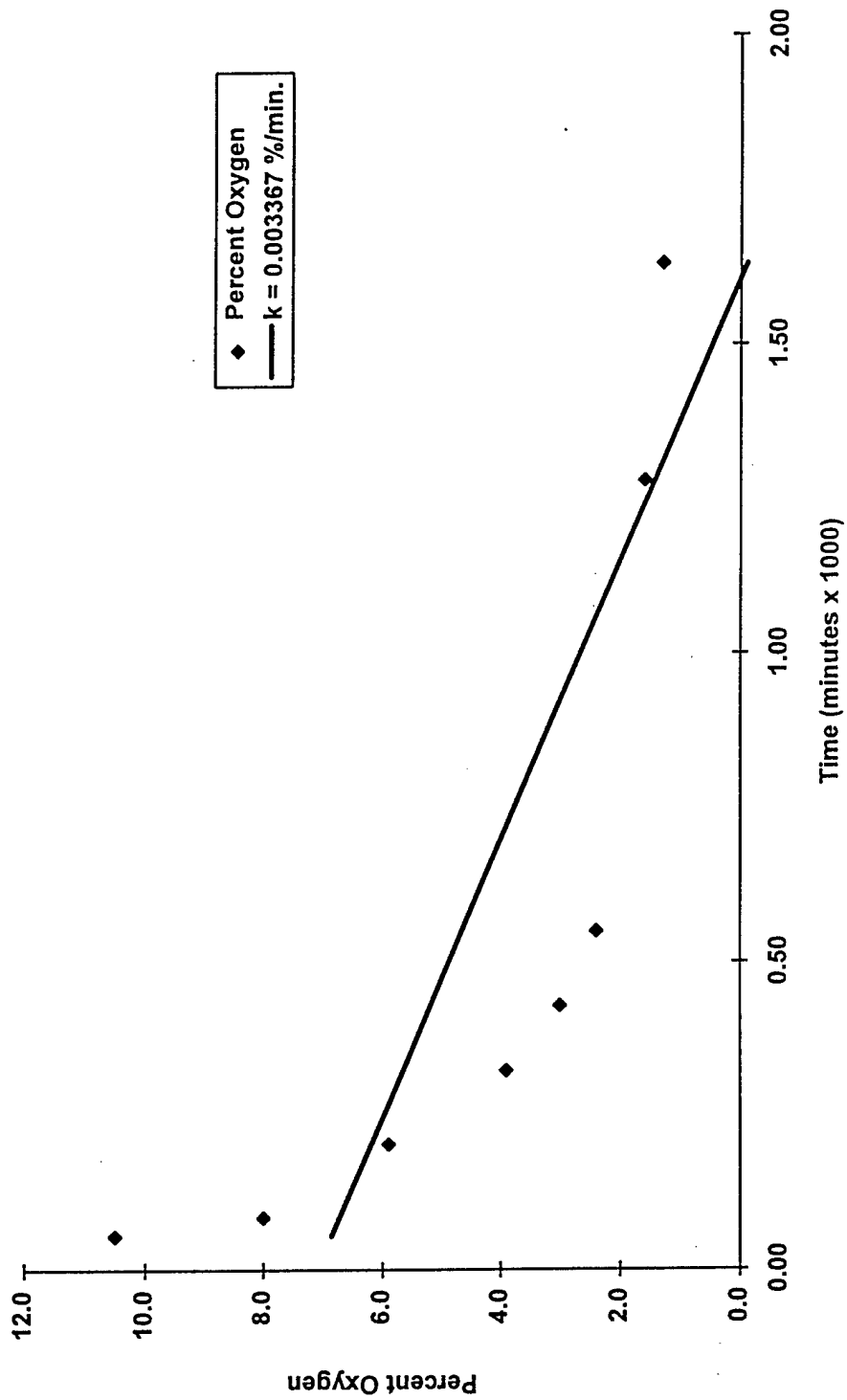

INITIAL RESPIRATION TEST
MONITORING POINT VW2
ST-08
POPE AFB, NC

