

# LOAN DOCUMENT

PHOTOGRAPH THIS SHEET

0

INVENTORY

DTIC ACCESSION NUMBER

LEVEL

LEVEL

*Operations + Maintenance Manual for...*

DOCUMENT IDENTIFICATION

*Jul 96*

**DISTRIBUTION STATEMENT A**  
Approved for Public Release  
Distribution Unlimited

DISTRIBUTION STATEMENT

DATE ACCESSIONED

DATE ACCESSIONED

DATE RETURNED

DATE RETURNED

REGISTERED OR CERTIFIED NUMBER

REGISTERED OR CERTIFIED NUMBER

ACCESSION FOR	
NTIS	GRAM <input checked="" type="checkbox"/>
DTIC	TRAC <input type="checkbox"/>
UNANNOUNCED	<input type="checkbox"/>
JUSTIFICATION	
BY	
DISTRIBUTION/	
AVAILABILITY CODES	
DISTRIBUTION	AVAILABILITY AND/OR SPECIAL
A-1	

DISTRIBUTION STAMP

20001215 109

DATE RECEIVED IN DTIC

PHOTOGRAPH THIS SHEET AND RETURN TO DTIC-FDAC

H  
A  
N  
D  
L  
E  
  
W  
I  
T  
H  
  
C  
A  
R  
E

**Operations and Maintenance Manual for  
Expanded Bioventing System at  
Buildings 2034/2035**



**Fairchild Air Force Base  
Washington**

**Prepared For**

**Air Force Center for Environmental Excellence  
Technology Transfer Division  
Brooks Air Force Base  
San Antonio, Texas**

**and**

**92 CES/CEV  
Fairchild Air Force Base  
Washington**

**July 1996**

 **PARSONS  
ENGINEERING SCIENCE, INC.**

1700 Broadway, Suite 900 • Denver, Colorado 80290

*AQM01-03-0552*

DEFENSE TECHNICAL INFORMATION CENTER  
REQUEST FOR SCIENTIFIC AND TECHNICAL REPORTS

Title AFCEE Collection

1. Report Availability (Please check one box)  
 This report is available. Complete sections 2a - 2f.  
 This report is not available. Complete section 3.

2a. Number of Copies Forwarded  
1 each

2b. Forwarding Date  
July 2000

2c. Distribution Statement (Please check ONE box)  
DoD Directive 5230.24, "Distribution Statements on Technical Documents," 18 Mar 87, contains seven distribution statements, as described briefly below. Technical documents MUST be assigned a distribution statement.  
 DISTRIBUTION STATEMENT A: Approved for public release. Distribution is unlimited.  
 DISTRIBUTION STATEMENT B: Distribution authorized to U.S. Government Agencies only.  
 DISTRIBUTION STATEMENT C: Distribution authorized to U.S. Government Agencies and their contractors.  
 DISTRIBUTION STATEMENT D: Distribution authorized to U.S. Department of Defense (DoD) and U.S. DoD contractors only.  
 DISTRIBUTION STATEMENT E: Distribution authorized to U.S. Department of Defense (DoD) components only.  
 DISTRIBUTION STATEMENT F: Further dissemination only as directed by the controlling DoD office indicated below or by higher authority.  
 DISTRIBUTION STATEMENT X: Distribution authorized to U.S. Government agencies and private individuals or enterprises eligible to obtain export-controlled technical data in accordance with DoD Directive 5230.25, Withholding of Unclassified Technical Data from Public Disclosure, 6 Nov 84.

2d. Reason For the Above Distribution Statement (in accordance with DoD Directive 5230.24)

2e. Controlling Office  
HQ AFCEE

2f. Date of Distribution Statement Determination  
15 Nov 2000

3. This report is NOT forwarded for the following reasons. (Please check appropriate box)  
 It was previously forwarded to DTIC on \_\_\_\_\_ (date) and the AD number is \_\_\_\_\_  
 It will be published at a later date. Enter approximate date if known. \_\_\_\_\_  
 In accordance with the provisions of DoD Directive 3200.12, the requested document is not supplied because:  
\_\_\_\_\_  
\_\_\_\_\_

Print or Type Name  
Laura Peña

Signature  
Laura Peña

Telephone  
210-536-1431

(For DTIC Use Only)  
AD Number M01-03-0552

# CONTENTS

	<u>Page</u>
SECTION 1 - INTRODUCTION .....	1-1
SECTION 2 - SYSTEM DESCRIPTION .....	2-1
2.1 Blower System .....	2-1
2.2 Monitoring and Flow Control Equipment .....	2-1
2.2.1 Monitoring Gauges .....	2-1
2.2.2 Flow Control Equipment.....	2-1
SECTION 3 - SYSTEM MAINTENANCE .....	3-1
3.1 Blower/Motor.....	3-1
3.2 Air Filter .....	3-1
3.3 Maintenance Schedule.....	3-1
3.4 Major Repairs .....	3-2
SECTION 4 - SYSTEM MONITORING .....	4-1
4.1 Blower Performance Monitoring .....	4-1
4.1.1 Vacuum/Pressure.....	4-1
4.1.2 Temperature .....	4-1
4.2 Monitoring Schedule .....	4-1
4.3 Reporting Monitoring Results.....	4-1
APPENDIX A Regenerative Blower Information	
APPENDIX B Data Collection Sheets	

# SECTION 1

## INTRODUCTION

This Operations and Maintenance (O&M) Manual has been created as a guide for monitoring and maintaining the performance of the full-scale bioventing blower system and vent well plumbing at Fairchild Air Force Base (AFB), Washington. Record drawings of the full-scale bioventing system installed at Building 2035 have been provided to Fairchild AFB.

Bioventing is the forced injection of fresh air, or withdrawal of soil gas, to enhance the supply of oxygen in subsurface soils for *in situ* bioremediation. A blower system is used to inject air into the soil, thereby supplying fresh atmospheric air (with approximately 20.8 percent oxygen) to contaminated soils. Once oxygen is provided to the subsurface, existing bacteria aerobically break down fuel residuals. Aerobic biodegradation is much more efficient than anaerobic biodegradation which occurs in oxygen depleted soils.

Parsons Engineering Science, Inc. (Parsons ES) has installed an air injection bioventing system consisting of two air injection blowers, four vent wells (VWs), eleven soil gas monitoring points (MPs), and associated piping at the site. The blower and single VW at Building 2034 was installed in October 1993 and began operating in March 1994. A blower and single VW was also installed at Building 2035 in October 1993 and operated from March 1994 to May 1996. In May 1996, the bioventing system at Building 2035 was expanded by replacing the blower with a larger model and the installation of additional VWs. The air injection rates of the expanded bioventing system were optimized at each vent well to assure adequate aeration of contaminated soils to promote aerobic biodegradation.

Fairchild AFB personnel are responsible for routine monitoring of the bioventing system. Parsons ES has trained Fairchild AFB personnel on the maintenance requirements of this plan. If significant problems are encountered with the operation of the system, Parsons ES should be notified so repairs can be made. Under the Extended Bioventing Project Option 1, Parsons ES is responsible for system repair for a 1-year period after system startup. Because additional system expansion is scheduled to be performed in August 1996, Parsons ES will retain responsibility for system repair until August 1997. Should the bioventing system cease to operate or develop a significant problem, please call the Parsons ES Site Manager, Mr. Brian Blicker, at (406) 586-7899. If the system ceases to operate, please have a base electrician verify that adequate power is being supplied to the bioventing system blower motor prior to notifying Parsons ES.

## SECTION 2

### SYSTEM DESCRIPTION

#### 2.1 BLOWER SYSTEM

A Gast® R4 blower powered by a 1-horsepower direct drive motor was installed at Building 2034 in October 1993. A Gast® R5 blower powered by a 2-horsepower direct-drive motor was installed at Building 2035 in May 1996. The R4 blower is rated as having a maximum flow rate of 92 standard cubic feet per minute (scfm) at open flow and a maximum pressure of a pressure of 52 inches of water. The R5 blower is rated as having a maximum flow rate of 160 scfm at open flow and a maximum pressure of 65 inches of water. As installed, the blower at Building 2034 was producing an estimated flow rate of 66 actual cubic feet per minute (acfm) at a pressure of 18 inches of water. Approximately 18 acfm is being injected into VW-2034-1 and the remainder of the flow is being bled. At Building 2035 the blower is producing an estimated flow rate of 110 acfm at a pressure of 18 inches of water. Approximately 18 acfm are being injected into each VW and the balance is being bled to the atmosphere. The blower systems include inlet air filters to remove any particulates which are entrained in the inlet air stream and several valves and monitoring gauges which are described in Section 2.2. A schematic of the full-scale blower system installed at Building 2035 is shown in the record drawings supplied to the base. Corresponding blower performance curves and relevant service information are provided in Appendix A.

#### 2.2 MONITORING AND FLOW CONTROL EQUIPMENT

##### 2.2.1 Monitoring Gauges

The bioventing system is equipped with vacuum, pressure, and temperature gauges, and air velocity measurement ports. Gauges have been installed on the air injection system at the following locations: a vacuum gauge in the inlet piping and pressure and temperature gauges in the outlet piping.

##### 2.2.2 Flow Control Equipment

Manual and automatic flow control valves (FCVs) have been installed on the bioventing blower system. Manual FCVs have been installed in the piping leading to each VW to enable the flow rate to each VW to be adjusted individually. An automatic FCV, or pressure relief valve (PRV), is used to protect the blower systems from burning out if pressures rise due to pipe blockage. The PRV is set to bleed off flow at a preset pressure and thus prevent blower outlet pressure from ever exceeding the rated pressure.

An additional FCV (bleed valve) has been installed to control the total air flow out of the blower by releasing excess air flow to the atmosphere. The FCVs have been set by Parsons ES personnel to deliver a calculated amount of air to each VW and should not be adjusted unless directed to do so by Parsons ES personnel.

The blower system has also been equipped with flow measurement ports. These ports consist of brass bushings installed in the outlet piping leading to each VW. These bushings, which should be plugged during system operation, allow the insertion of a thermal anemometer for the measurement of air velocity. These ports are used by Parsons ES for system optimization.

Although the blower systems installed at Buildings 2034/2035 are relatively maintenance free, periodic system maintenance is required for proper operation and long life. Recommended maintenance procedures and schedule are described in detail in the instruction manuals included in Appendix A and briefly summarized in this section.

Filter inspection must be performed with the system turned off. Do not change the flow control valve settings (valves have been pre-set for a specific flow rate) before re-starting the blower.

## SECTION 3

### SYSTEM MAINTENANCE

#### 3.1 BLOWER/MOTOR

The blower and motor are relatively maintenance free and should not require any maintenance during the operational period. Both the blower and motor have sealed bearings and do not require lubrication.

#### 3.2 AIR FILTER

To avoid damage caused by passing solids through the blower, an air filter has been installed in-line before the blower. The paper filter element is accompanied by a polyurethane foam pre-filter. The filter should be checked weekly for the first 2 months of operation. A facility employee should determine the best schedule for filter replacement based on the first 2 months of system monitoring. The polyurethane pre-filters can be washed with lukewarm water and a mild detergent. Paper filter elements should never be washed, and should be disposed of and replaced as necessary. When the vacuum drop across the filter increases by approximately 10 inches of water from the vacuum when the filter was new, a dirty filter element should be suspected, and cleaning or replacement should be performed. The initial vacuum when the filter element was new was 9 inches of water. Therefore, the filter should be cleaned or replaced when the vacuum increases to 19 inches of water. Typical filter element replacement intervals range from 3 to 6 months.

To remove the filter, turn the system off by pushing the stop button on the starter, loosen the three clamps or the wing nut on the filter top, lift the metal top off the air filter, and lift the air filter element from the metal housing. Remove the polyurethane pre-filter (if applicable) and wash before replacing.

The filter element is manufactured by Solberg Manufacturing, Inc. in Itasca, Illinois. Their telephone number is (708) 773-1363. Additional filters can also be obtained through Parsons ES. The Parsons ES contacts are Mr. Brian Blicher (406) 586-7899 and Mr. Craig Snyder (303) 831-8100. The part number for the replacement filter element is 30P. Four spare air filter elements have been placed inside the blower enclosure.

#### 3.3 MAINTENANCE SCHEDULE

The following maintenance schedule is recommended for the blower system. During the initial few months of operation more frequent monitoring is recommended to ensure that any startup problems are quickly corrected. A daily drive-by inspection is recommended during

the initial 2 weeks of operation to ensure that the blower system is still operating with no unusual sounds. Thereafter monitoring inspections every 2 weeks are recommended (see Section 4). Preprinted data collection sheets have been provided to the facility. Extra data collection sheets for recording maintenance activities are provided in Appendix B.

<u>Maintenance Item</u>	<u>Maintenance Frequency</u>
Filter	Check once every 2 weeks, wash or replace as necessary (see Section 3.3). Inlet vacuum exceeding 19 inches of water indicates that the filter requires cleaning or replacement.

### 3.4 MAJOR REPAIRS

Blowers systems are very reliable when properly maintained. Occasionally, however, a motor or blower will develop a serious problem. If a blower system fails to start, and a qualified electrician verifies that power is available at the blower or starter, Parsons ES should be contacted to arrange for repairs. The Parsons ES contacts are Mr. Brian Blicher (406) 586-7899 and Mr. Craig Snyder (303) 831-8100. Parsons ES is responsible for major repairs during the first year of operation.

## SECTION 4

### SYSTEM MONITORING

#### 4.1 BLOWER PERFORMANCE MONITORING

To monitor the blower performance, the vacuum, pressure, and temperature will be measured. These data should be recorded every 2 weeks on a data collection sheet (provided in Appendix B). All measurements should be taken at the same time while the system is running. Because the systems are noisy, hearing protection should be worn at all times.

##### 4.1.1 Vacuum/Pressure

With hearing protection in place, unlock and open the blower enclosure and record all vacuum and pressure readings directly from the gauges (in inches of water). Record the measurements on the data collection sheet.

##### 4.1.2 Temperature

With hearing protection in place, open the blower enclosure and record the temperature readings directly from the gauges in degrees Fahrenheit (°F). Record the measurements on a data collection sheet (provided in Appendix B). The temperature change can be converted to degrees Celsius (°C) using the formula  $^{\circ}\text{C} = (^{\circ}\text{F} - 32) \times 5/9$ .

#### 4.2 MONITORING SCHEDULE

The following monitoring schedule is recommended for these systems. During the initial month of operation, more frequent monitoring is recommended to ensure that any start up problems are quickly corrected. Data collection sheets have been provided to assist your data collection and are included in Appendix B.

<u>Monitoring Item</u>	<u>Monitoring Frequency</u>
Vacuum/Pressure	Once every 2 weeks.
Temperature	Once every 2 weeks.

#### 4.3 REPORTING MONITORING RESULTS

System monitoring data sheets should be faxed to the Parsons ES Site Manager, Mr. Brian Blicker at (406) 586-7899, once every 2 months. However, if a significant change in the

system temperature or pressure is noted (such as a significant drop or increase in pressure) please call Mr. Blicher at (970) 244-8829 immediately. A significant change in system temperature or pressure may be indicative of a problem with the air delivery system or blower.

**APPENDIX A**

**REGENERATIVE BLOWER INFORMATION**



Post Office Box 97  
Benton Harbor, Michigan 49023-0097  
Ph: 616/926-6171  
Fax: 616/925-8288

## Maintenance Instructions for Gast Standard Regenerative Blowers

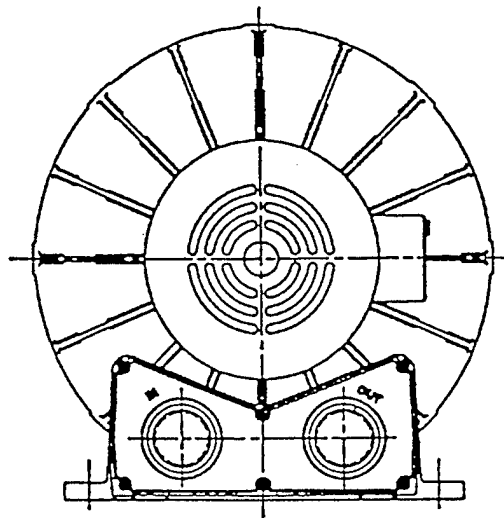
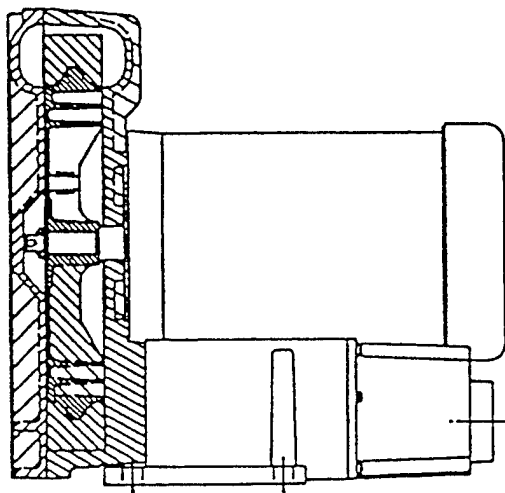

For original equipment manufacturers  
special models, consult your local distributor

### Gast Rebuilding Centers

Gast Mfg. Corp.  
2550 Meadowbrook Rd.  
Benton Harbor MI. 49022  
Ph: 616/926-6171  
Fax: 616/925-8288

Gast Mfg Corp.  
505 Washington Avenue  
Carlstadt, N. J. 07072  
Ph: 201/933-8484  
Fax: 201/933-5545

Brenner Fiedler. & Assoc.  
13824 Bentley Place  
Cerritos, CA. 90701  
Ph: 213/404-2721  
Fax: 213/404-7975

Wainbee, Limited  
121 City View Drive  
Toronto, Ont. Canada M9W 5A9  
Ph: 416/243-1900  
Fax: 416/243-2336

Wainbee, Limited  
215 Brunswick Drive  
Pointe Claire, P.Q. Canada H9R 4R7  
Ph: 514/697-8810  
Fax: 514/697-3070

Gast Mfg. Co. Limited.  
Halifax Rd, Cressex Estate  
High Wycombe, Bucks HP12 3SN  
Ph. 44 494 523571  
Fax: 44 494 436588

Japan Machinery Co. Ltd.  
Central PO Box 1451  
Tokyo 100-91 Japan  
Ph: 813/3573-5421  
Fax: 813/3571-7865

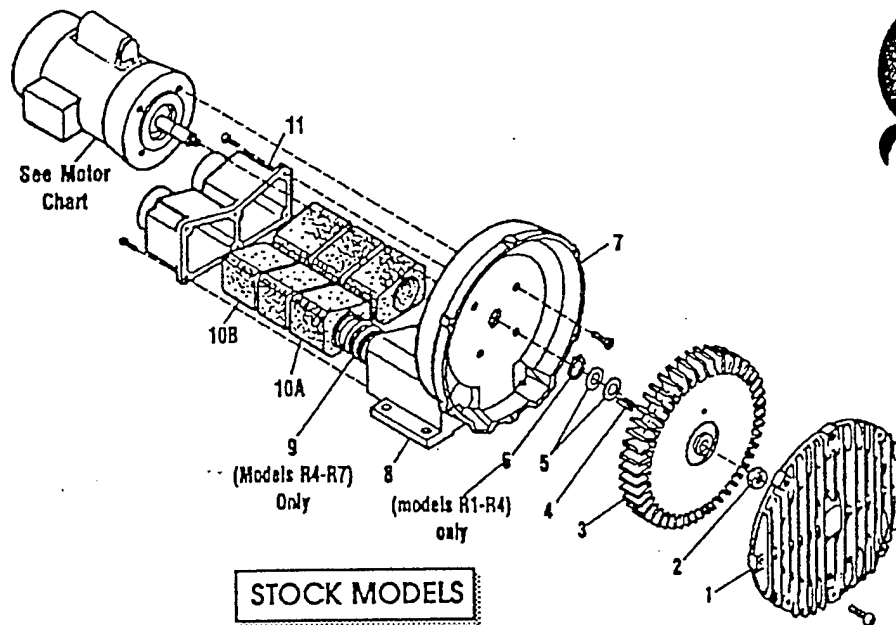

**STOCK MODELS**

Part Name	R1	R2	R3	R4	R5	R6	R6P	R6PP/R6PS	R7
#1 Cover	AJ101A	AJ101B	AJ101C	AJ101D	AJ101EQ	AJ101F	AJ101K	(2)AJ101KA	AJ101G
#2 Stopnut	BC187	BC187	BC181	BC181	BC181	BC181	BC181	(2)BC182	BC183
#3 Impeller	AJ102A	AJ102BQ	AJ102C	AJ102D	AJ102E	AJ102FR	AJ102K	(2)AJ102KA	AJ102GA
#4 Square Key	AH212C	AH212	AB136A	AB136D	AB136	AB136	AB136	(2)AB136	AC628
#5 Shim Spacer (s)	AJ132	AE686-3	AJ109	AJ109	AJ109	AJ116A	AJ116A	AJ116A	AJ110
#6 Retaining Ring	AJ145	AJ145	AJ149	AJ149					
#7 Housing	AJ103A	AJ103BQ	AJ103C	AJ103DR	AJ103E	AJ103F	AJ103K	AJ103KD	AJ103GA
#8 Muffler Box					AJ104E	AJ104F			
#9 Spring				AJ113DR	AJ113DQ	AJ113FQ	AJ113FQ		AJ113G
#10A Foam	(4)AJ112A	(4)AJ112B	(4)AJ112C	(4)AJ112DS	(4)AJ112ER	(6)AJ112F	(8)AJ112K		(8)AJ112GA
#10B Foam		(2)AJ112BQ	(2)AJ112CQ	(2)AJ112DR	(2)AJ112EQ				
#11 Muffler Extension/ Adapter Plate	AJ106H	AJ106BQ	AJ106CQ	AJ106DQ	AJ106EQ	AJ106FQ	AJ104K		AJ104GA
Shlm Kit	K396	K396							K395

**MOTOR CHART**

REGENAIR MODEL NUMBER	MOTOR NUMBER	MOTOR SPECIFICATIONS		PHASE
		60 HZ VOLTS	50 HZ VOLTS	
R1102	J111X	115/208-230	110/220-240	1
R1102C	J112X	115		1
R2103	J311X	115/208-230	110/220	1
R2105	J411X	115/208-230	110/220	1
R2303A	J310	208-230/460	220/380-415	3
R2303F	J313	208-230	220	3
R3105-1/R3105-12	J411X	115/208-230	110/220-240	1
R3305A-1/R3305A-13	J410	208-230/460	220/380-415	3
R4110-2	J611AX	115/208-230	110/220-240	1
R4310A-2	J610	208-230/460	220/380-415	3
R5125-2	J811X	115/208-230		1
R5325A-2	J810X	208-230/460	220/380-415	3
R6125-2	J811X	115/208-230		1
R6325A-2	J810X	208-230/460	220/380-415	3
R6335A-2	J910X	208-230/460	220/380-415	3
R6150J-2	J1013	230		1
R6350A-2	J1010	208-230/460	220/380-415	3
R6P335A	J910X	208-230/460	220/380-415	3
R6P350A	J1010	208-230/460	220/380-415	3
R6P355A	J1110A	208-230/460	220/380-415	3
R7100A-2	J1210B	208-230/460	220/380-415	3
R6PP/R6PS110M	JD1100	208-230/460	220/380-415	3

\* No lubrication needed at start up. Bearings lubricated at factory.

\* Motor is equipped with alemite fitting. Clean tip of fitting and apply grease gun. Use 1 to 2 strokes of high quality ball bearing grease.

Consistency	Type	Typical Grease
Medium	Lithium	Shell Dolum R

Hours of service per year

Suggested Relube Interval

5,000

3 years

Continual Normal Application

1 year

Seasonal service motor idle for 6 months or more

1 year beginning of season  
6 months

Continuous-high ambients, dirty or moist applications.

All performance figures relate to stock models. A few high pressure units may be available. Consult your local distributor.

Regenair Model Number	P R E S S U R E						Maximum Pressure "H <sub>2</sub> O"
	0"H <sub>2</sub> O	20"H <sub>2</sub> O	40"H <sub>2</sub> O	60"H <sub>2</sub> O	80"H <sub>2</sub> O	100"H <sub>2</sub> O	
R1	26	14					28
R2	42	26					38
R3105-1	52	38	14				42
R3105-12	52	36	23				55
R3305A-13	52	36	23				55
R4	90	70	50				52
R5	145	130	100				65
R6125-2	200	180					35
R6325A-2	200	180	152				40
R6335A-2	205	175	155	135			70
R6350A-2	200	180	150	130	110	80	105
R6P335A	290	250					30
R6P350A	300	260	230	200			60
R6P355A	300	260	230	200	160		90
R7100A-2	420	380	340	310	280	230	115
R6PP311OM	485	452	420	380	330		95
R6PS311OM	265	258	252	244	236	226	170

Regenair Model Number	V A C U U M					Maximum Vacuum "H <sub>2</sub> O"
	0"H <sub>2</sub> O	20"H <sub>2</sub> O	40"H <sub>2</sub> O	60"H <sub>2</sub> O	80"H <sub>2</sub> O	
R1	25	14				26
R2	40	22				34
R3105-1	50	34	9			40
R3105-12	51	34	20			50
R3305A-13	51	34	20			50
R4	82	62	39			48
R5	140	115	90	50		60
R6125-2	190	155	125			45
R6325A-2	190	155	125			45
R6335A-2	190	150	125	100		75
R6350A-2	190	180	150	100	70	90
R6P335A	270	230				37
R6P350A	280	240	210	170		70
R6P355A	280	240	210	170	100	86
R7100A-2	410	350	300	250	170	90
R6PP311OM	470	425	375	320	220	80
R6PS311OM	240	225	210	195	175	130

\*This number indicates the maximum static pressure differential recommended (with cooling air still flowing through unit). In general, units 1hp or less can be dead headed. Check with local representative or distributor to verify which models apply.

Operation of the blower above the recommended maximum duty will cause premature failure due to the build up of heat damaging the components.

Performance data was determined under the following conditions:

- 1) Unit in a temperature stable condition.
- 2) Test conditions: Inlet air density at 0.075lbs. per cubic foot. (20°C(68°F), 29.92 in. Hg(14.7PSIA)).
- 3) Normal performance variations on the resistance curve within +/- 10% of supplied data can be expected.
- 4) Specifications subject to change without notice.
- 5) All performance at 60Hz operation.

# Oilless Regenerative Blowers, Motor Mounted to 88 cfm



## REGENAIR® R4 Series

VACUUM

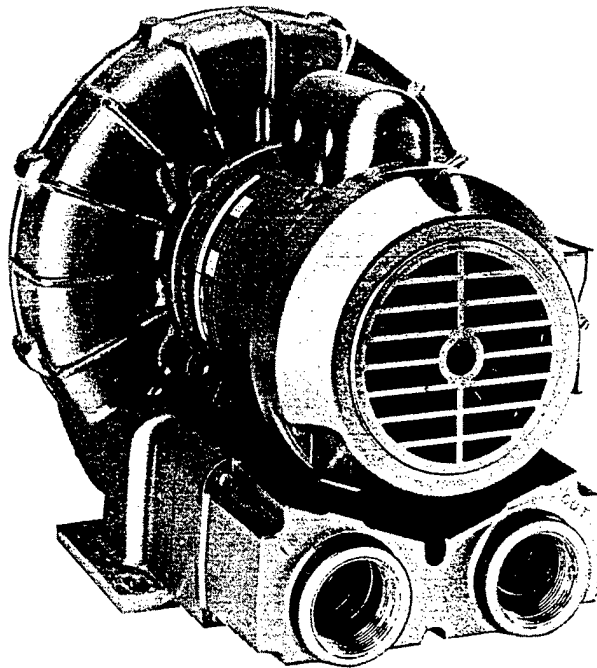

**MODEL R4110-2**  
48" H<sub>2</sub>O MAX. VAC., 88 CFM OPEN FLOW

### PRODUCT FEATURES

- Oilless operation
- TEFC motor mounted
- Can be mounted in any plane
- Rugged construction/low maintenance
- Can be operated with no air flow through unit
- Class B insulation on motors
- Automatic restart thermal protection on single phase motors

### COMMON MOTOR OPTIONS

- 115/208-230V, 60 Hz; 110/220-240V, 50 Hz, single phase
- 208-230/460V, 60 Hz; 190-220/380-415V, 50 Hz, three phase
- 575V, 60 Hz, three phase

### RECOMMENDED ACCESSORIES

- Vacuum gauge AJ497
- Filter AJ151D
- Muffler AJ121D
- Relief valve AG258
- Nema motor starter (reference Blower Catalog accessory section or consult your Gast representative)

Various brand name motors are used on any model at the discretion of Gast Mfg. Corp.

### Product Dimensions Metric (mm) U.S. Imperial (inches)

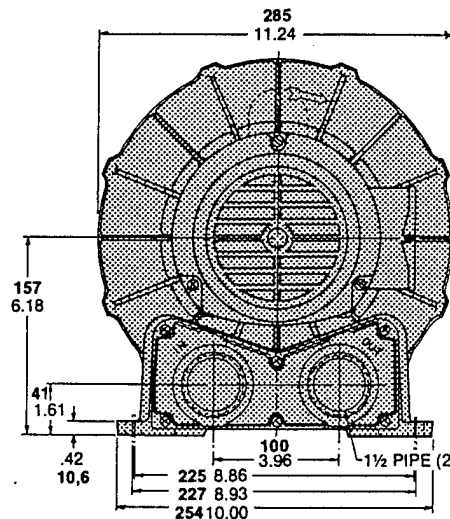
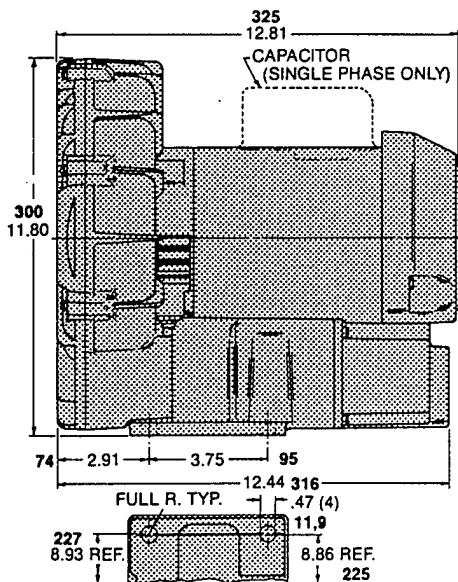

### Important Notice:

Pictorial and dimensional data is subject to change without notice.

## Product Specifications

Model Number	Motor Specs	Full Load Amps	HP	RPM	Max Vac		Max Flow		Net Wt.	
					"H <sub>2</sub> O	mbar	cfm	m <sup>3</sup> /h	lbs.	kg
R4110-2	110/220-240-50-1	9.0/4.5-5.7	0.6	2850	34	85	72	122	41	18,6
	115/208-230-60-1	9.8/5.2-4.9	1.0	3450	48	120	88	150		
R4310A-2	190-220/380-415-50-3	2.6-3.3/1.3-1.4	0.6	2850	34	85	72	122	41	18,6
	208-230/460-60-3	3.4-3.2/1.6	1.0	3450	48	120	88	150		

## Product Performance (Metric U.S. Imperial)

Black line on curve is for 60 cycle performance.  
Blue line on curve is for 50 cycle performance.

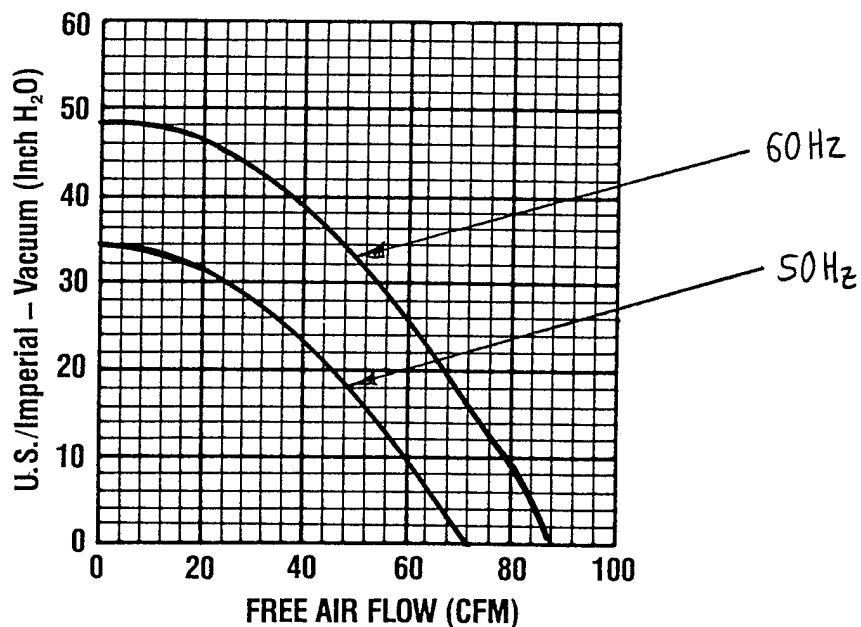
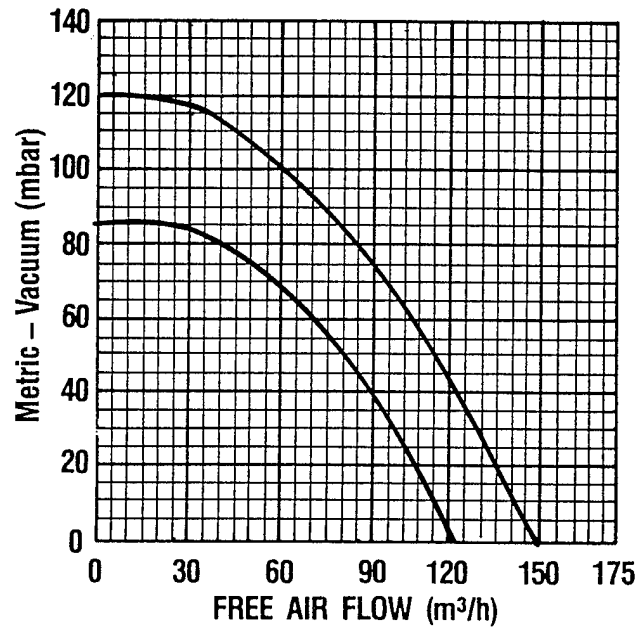

# Oilless Regenerative Blowers, Motor Mounted to 145 cfm



## REGENAIR® R5 Series

VACUUM

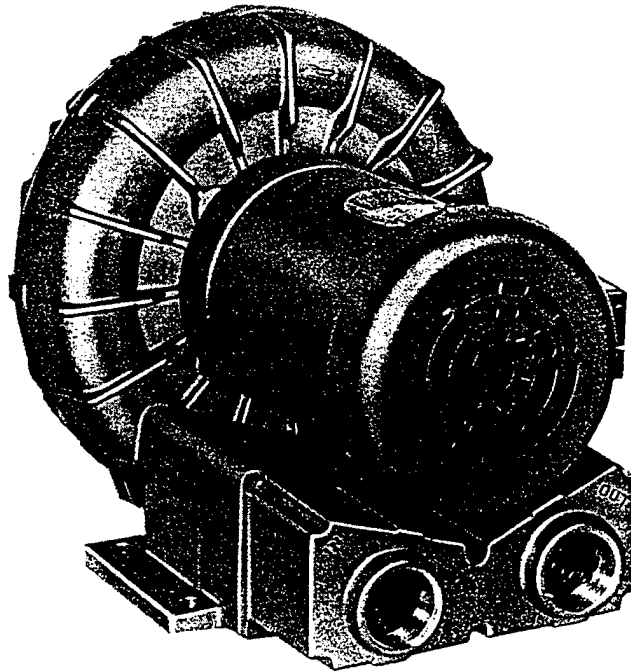

**MODEL R5325A-2**  
60" H<sub>2</sub>O MAX. VAC., 145 CFM OPEN FLOW

### PRODUCT FEATURES

- Oilless operation
- TEFC motor mounted
- Can be mounted in any plane
- Rugged construction/low maintenance
- Class B insulation on motors
- Automatic restart thermal protection on motors

### COMMON MOTOR OPTIONS

- 115/208-230V, 60 Hz; 110/220-240V, 50 Hz, single phase
- 208-230/460V, 60 Hz; 190-220/380-415V, 50 Hz, three phase
- 575V, 60 Hz, three phase

### RECOMMENDED ACCESSORIES

- Vacuum gauge AJ497
- In-line filter AJ151E
- Muffler AJ121D
- Relief valve AG258
- Nema motor starter (reference Blower Catalog accessory section or consult your Gast representative)

Various brand name motors are used on any model at the discretion of Gast Mfg. Corp.

### Important Notice:

Pictorial and dimensional data is subject to change without notice.

### Product Dimensions Metric (mm) U.S. Imperial (inches)

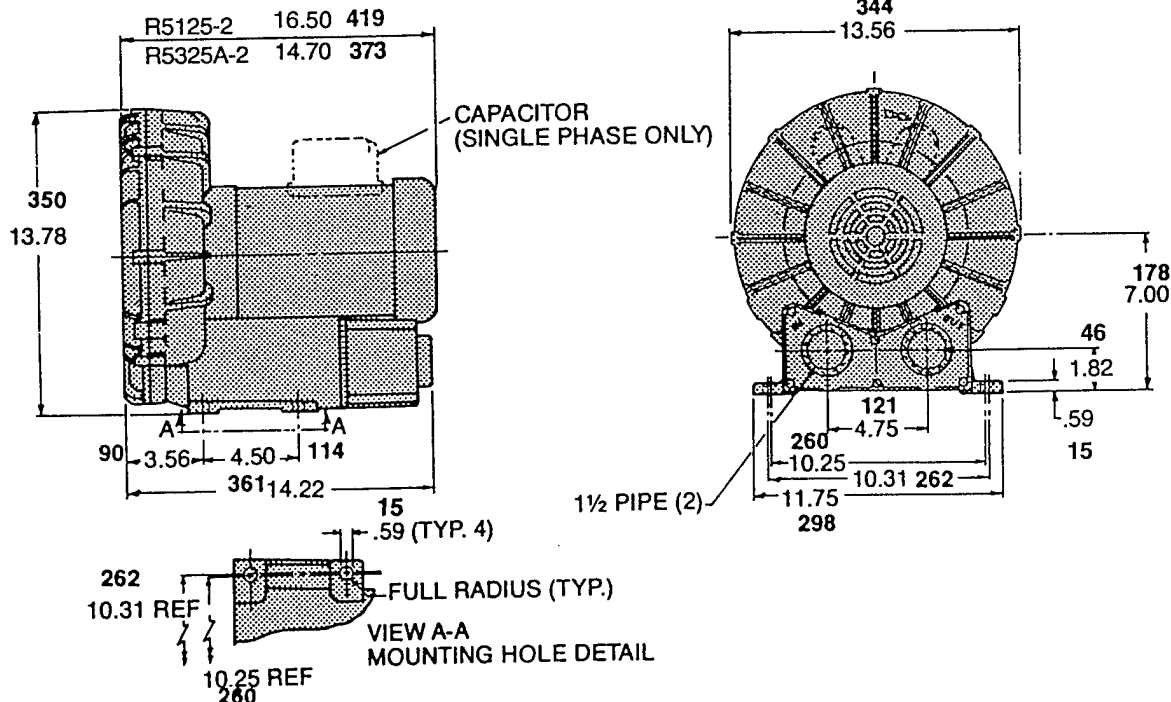

## Product Specifications

Model Number	Motor Specs	Full Load Amps	HP	RPM	Max Vac		Max Flow		Net Wt.	
					"H <sub>2</sub> O	mbar	cfm	m <sup>3</sup> /h	lbs.	kg
R5325A-2	190-220/380-415-50-3	6.6-6.7/3.3-3.5	1.85	2850	47	117	120	204	65	29,5
	208-230/460-60-3	6.9/3.45	2.5	3450	60	149	145	246		
R5125-2	110/220-240-50-1	17.6/8.8-9.5	1.5	2850	47	117	120	204	76	34,5
	115/208-230-60-1	23.6/12.9-11.8	2.5	3450	60	149	145	246		

**Product Performance (Metric U.S. Imperial)**      Black line on curve is for 60 cycle performance.  
 Blue line on curve is for 50 cycle performance.

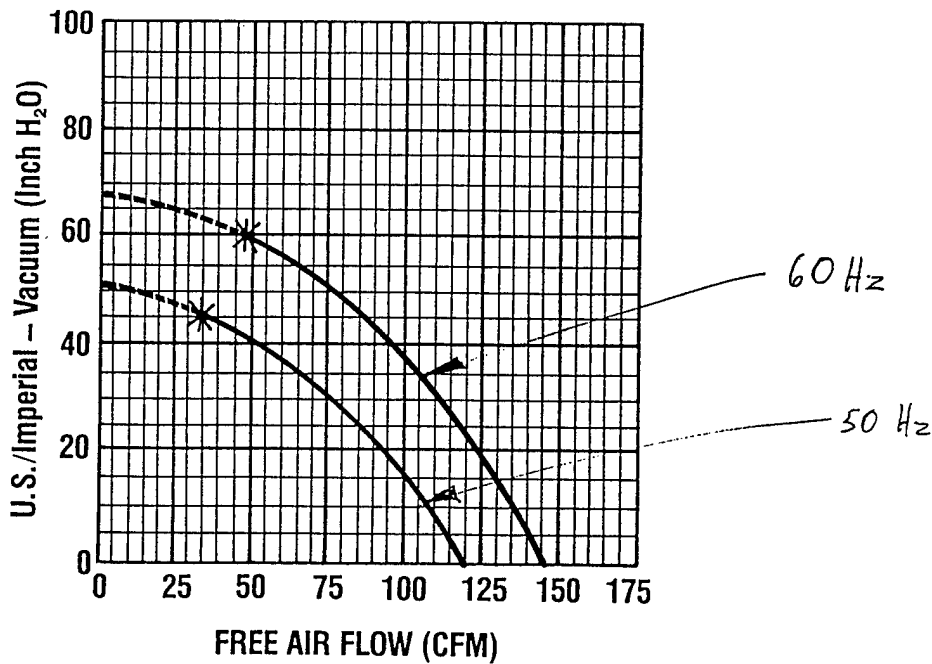
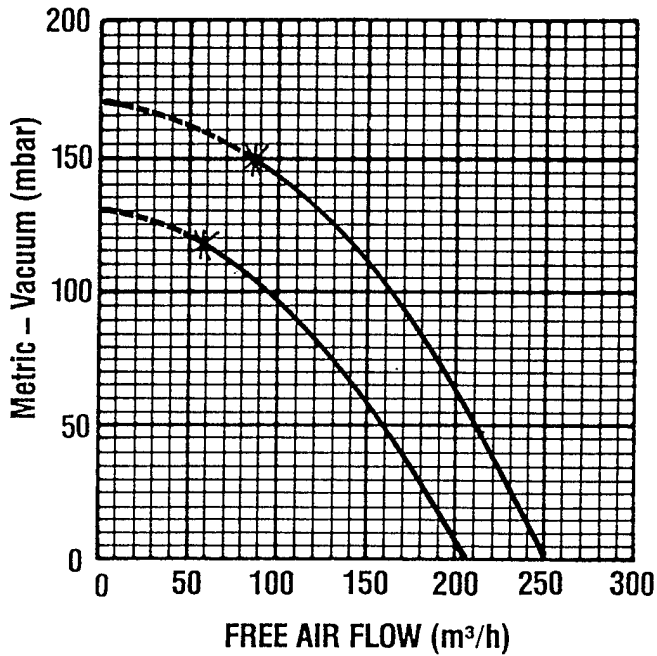

\*Recommended maximum duty.  
 ---- Intermittent duty only.



70-6100  
F2-205/8/92  
Rev. E

Post Office Box 97  
Benton Harbor, MI. 49023-0097  
Ph: 616/926-6171  
Fax: 616/925-8288

# INSTALLATION AND OPERATING INSTRUCTIONS FOR GAST HAZARDOUS DUTY REGENAIR BLOWERS

This instruction applies to the following models ONLY: R3105N-50, R4110N-50, R4310P-50, R4P115N-50, R5125Q-50, R5325R-50, R6130Q-50, R6P155Q-50, R6350R-50, R6P355R-50 and R7100R-50.

*Gast Authorized Service Facilities are Located in the locations listed below*

Gast Manufacturing Corporation  
505 Washington Avenue  
Carlstadt, N. J. 07072  
Ph: 201/933-8484  
Fax: 201/933-5545

Gast Manufacturing Corporation  
2550 Meadowbrook Road  
Benton Harbor, MI. 49022  
Ph: 616/926-6171  
Fax: 616/925-8288

Brenner Fiedler & Associates  
13824 Bentley Place  
Cerritos, CA. 90701  
Ph: 310/404-2721  
Ph: 800/843-5558  
Fax: 310/404-7975

Wainbee Limited  
215 Brunswick Blvd.  
Pointe Claire, Quebec  
Canada H9R 4R7  
Ph: 514/697-8810  
Fax: 514/-697-3070

Wainbee Limited  
5789 Coopers Ave.  
Mississauga, Ontario  
Canada L4Z 3S6  
Ph: 416/243-1900  
Fax: 416/243-2336

Japan Machinery  
Central PO Box 1451  
Toyko 100-91, Japan  
Ph: 813 3573-5421  
Fax: 813 3571-7896

Gast Manufacturing Co. Ltd.  
Halifax Road, Cressex Estate  
High Wycombe, Bucks HP12 3SN  
England  
Ph: 44 494 523571  
Fax: 44 494 436588.

# OPERATING AND MAINTENANCE INSTRUCTIONS

## SAFETY

This is the safety alert symbol. When you see this symbol personal injury is possible. The degree of injury is shown by the following signal words:

- ⚠ DANGER** Severe injury or death will occur if hazard is ignored.
- ⚠ WARNING** Severe injury or death can occur if hazard is ignored.
- ⚠ CAUTION** Minor injury or property damage can occur if hazard is ignored.

Review the following information carefully before operating.

## GENERAL INFORMATION

*This instruction applies to the following models ONLY: R3105N-50, R4110N-50, R4310P-50, R4P115N-50, R5125Q-50, R5325R-50, R6130Q-50, R6P155Q-50, R6350R-50, R6P355R-50 and R7100R-50.* These blowers are intended for use in Soil Vapor Extraction Systems. The blowers are sealed at the factory for very low leakage. They are powered with a U.L. listed electric motor Class 1 Div. 1 Group D motors for Hazardous Duty locations. Ambient temperature for normal full load operation should not exceed 40° C (105° F). For higher ambient operation, contact the factory.

Gast Manufacturing Corporation may offer general application guidance: however, suitability of the particular blower and/or accessories is ultimately the responsibility of the user, not the manufacturer of the blower.

## INSTALLATION

- ⚠ DANGER** Models R5325R-50, R6130Q-50, R6350R-50, R5125Q-50, R6P155Q-50, R6P355R-50 AND R7100R-50 use Pilot Duty Thermal Overload Protection. Connecting this protection to the proper control circuitry is mandated by UL674 and NEC501. Failure to do so could/ may result in a EXPLOSION. See pages 3 and 4 for recommended wiring schematic for these models.

- ⚠ WARNING** Electric shock can result from bad wiring. A qualified person must install all wiring, conforming to all required safety codes. Grounding is necessary.

- ⚠ WARNING** This blower is intended for use on soil vapor extraction equipment. Any other use must be approved in writing by Gast Manufacturing Corp. Install this blower in any mounting position. Do not block the flow of cooling air over the blower and motor.

**PLUMBING** - Use the threaded pipe ports for connection only. They will not support the plumbing. Be sure to use the same or larger size pipe to prevent air flow restriction and overheating of the blower. When installing fittings, be sure to use pipe thread sealant. This protects the threads in the blower housing and prevents leakage. Dirt and chips are often found in new plumbing. Do not allow them to enter the blower.

**NOISE** - Mount the unit on a solid surface that will not increase the sound. This will reduce noise and vibration. We suggest the use of shock mounts or vibration isolation material for mounting.

**ROTATION** - The Gast Regenair Blower should only rotate clockwise as viewed from the electric motor side. The casting has an arrow showing the correct direction. Confirm the proper rotation by checking air flow at the IN and OUT ports. If needed reverse rotation of three phase motors by changing the position of any two of the power line wires.

## OPERATION

- ⚠ WARNING** Solid or liquid material exiting the blower or piping can cause eye damage or skin cuts. Keep away from air stream.

- ⚠ WARNING** - Gast Manufacturing Corporation will not knowingly specify, design or build any blower for installation in a hazardous, combustible or explosive location without a motor conforming to the proper NEMA or U. L. standards. Blowers with standard TEFC motors should never be utilized for soil vapor extraction applications or where local state and/or Federal codes specify the use of explosion-proof motors (as defined by the National Electric Code, Articles 100,500 c1990).

- ⚠ CAUTION** Attach blower to solid surface before starting to prevent injury or damage from unit movement. Air containing solid particles or liquid must pass through a filter before entering the blower. Blowers must have filters, other accessories and all piping attached before starting. Any foreign material passing through the blower may cause internal damage to the blower.

- ⚠ CAUTION** Outlet piping can burn skin. Guard or limit access. Mark "CAUTION Hot Surface. Can Cause Burns". Air temperature increases when passing through the blower. When run at duties above 50 in. H<sub>2</sub>O, metal pipe may be required for hot exhaust air. The blower must not be operated above the limits for continuous duty. Only models R3105N-50, R4110N-50 and R4310P-50 can be operated continuously with no air flowing through the blower. Other units can only be run at the rating shown on the model number label. Do not Close off inlet (for vacuum) to reduce extra air flow. This will cause added heat and motor load. Blower exhaust air in excess of 230°F indicates operation in excess of rating which can cause the blower to fail.

**ACCESSORIES** ...Gast pressure gauge AJ496 and vacuum gauges AJ497 or AE134 show blower duty. The Gas pressure/vacuum relief valve, AG258, will limit the operating duty by admitting or relieving air. It also allows full flow through the blower when the relief valve closes.

**SERVICING**

**⚠ WARNING** To retain their sealed construction they should be serviced by Gast authorized service centers ONLY. These models are sealed at the factory for very low leakage.

**⚠ WARNING** Turn off electric power before removing blower from service. Be sure rotating parts have stopped. Electric shock or severe cuts can result. Inlet and exhaust filters attached to the blower may need cleaning or replacement of the elements. Failure to do so will result in more pressure drop, reduced air flow and hotter operation of the blower.

The outside of the unit requires cleaning of dust and dirt. The inside of the blower also may need cleaning to remove foreign material coating the impeller and housing. This should be done at a Gast Authorized Service Center. This buildup can cause vibration, failure of the motor to operate or reduced flow.

**KEEP THIS INFORMATION WITH THIS BLOWER. REFER TO IT FOR SAFE INSTALLATION, OPERATION OR SERVICE.**

**MOTOR WIRING DIAGRAM FOR R4110N-50 & R3105N-50**

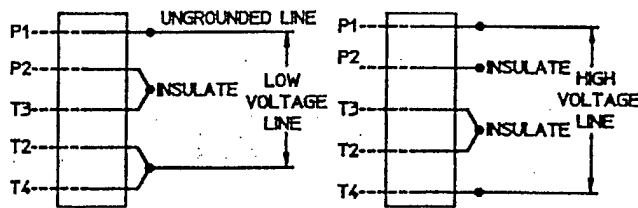

**>> \* WARNING**  
THIS MOTOR IS THERMALLY PROTECTED AND WILL AUTOMATICALLY RESTART WHEN PROTECTOR RESETS. ALWAYS DISCONNECT POWER SUPPLY BEFORE SERVICING.

**MOTORS WIRING DIAGRAM FOR R4310P-50**

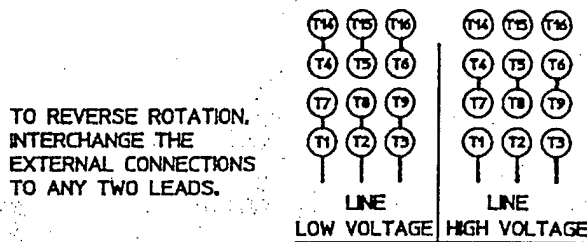

TO REVERSE ROTATION, INTERCHANGE THE EXTERNAL CONNECTIONS TO ANY TWO LEADS.

**>> \* WARNING**  
THIS MOTOR IS THERMALLY PROTECTED AND WILL AUTOMATICALLY RESTART WHEN PROTECTOR RESETS. ALWAYS DISCONNECT POWER SUPPLY BEFORE SERVICING.

**MOTORS WIRING DIAGRAM FOR R5325R-50, R6350R-50, R6P355R-50, & R7100R-50**

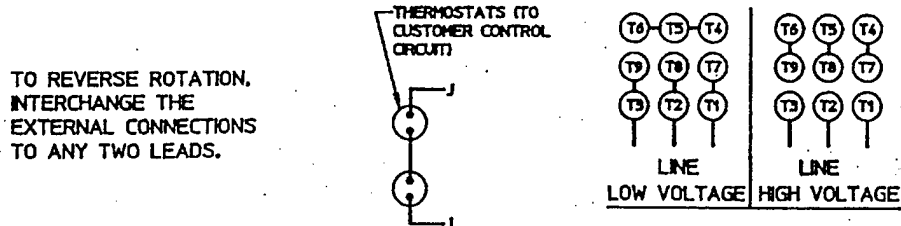

TO REVERSE ROTATION, INTERCHANGE THE EXTERNAL CONNECTIONS TO ANY TWO LEADS.

LINE LOW VOLTAGE LINE

## MOTOR WIRING DIAGRAM FOR R5125Q-50 & R4P115N-50

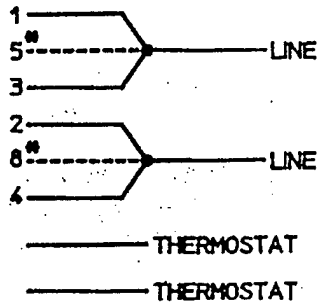

LOW VOLTAGE

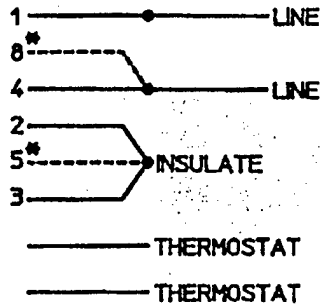

HIGH VOLTAGE

\* R5125Q-50 BLOWERS PRODUCED AFTER SEPTEMBER 1992 (SER. NO. 0992) DO NOT HAVE MOTOR LEADS 5 & 8.

## MOTOR WIRING DIAGRAM FOR R6130Q-50 & R6P155Q-50

CONNECT THERMOSTAT TO MOTOR PROTECTION CIRCUIT

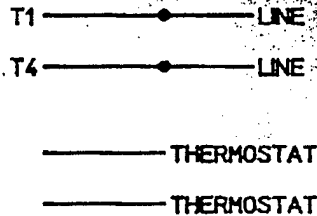

## CONNECTION FOR THERMOSTAT MOTOR PROTECTION

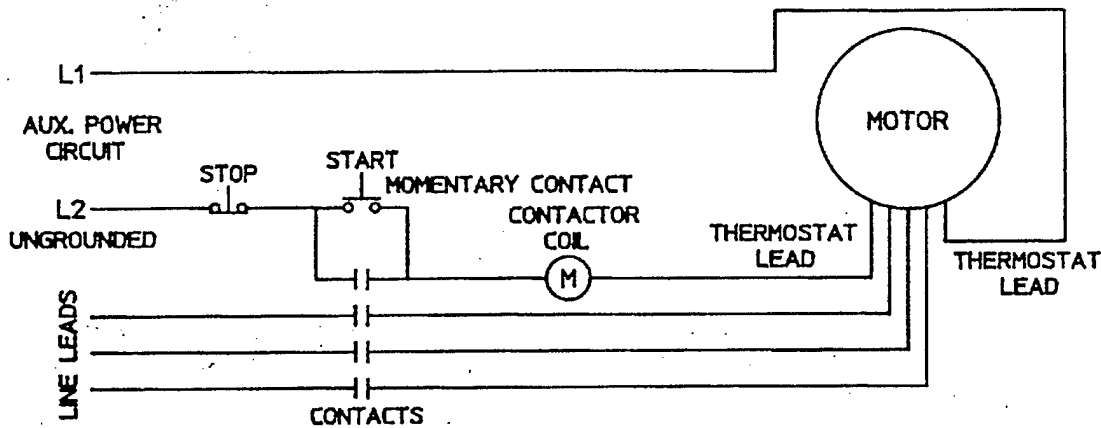

THERMOSTATS TO BE CONNECTED IN SERIES WITH CONTROL AS SHOWN. MOTOR FURNISHED WITH AUTOMATIC THERMOSTATS RATED A.C. 115-600V. 720VA

AK811 rev. E

## Relief Valve

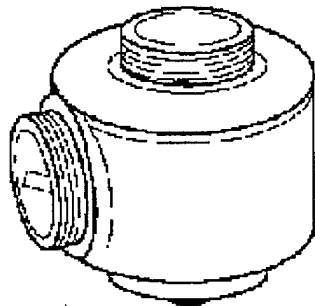

By setting a relief valve at a given pressure/vacuum, you can ensure excessive duties will not harm the blower or products in your application.

AG258	Relief valve	1½-inch NPT adjustable 30-200 inches H <sub>2</sub> O, vacuum or pressure, 200 CFM max
AG258F	Relief valve	2½-inch NPT adjustable 30-200 inches H <sub>2</sub> O, vacuum or pressure, 550 CFM max

[Print Form](#)

[Click Here for Catalog](#)

**Gast Manufacturing Corp.**  
**P.O. Box 97**  
**Benton Harbor, MI 49023-0097**  
**(616) 926-6171**

## **Warranty**

REGARDLESS OF CAUSE, if a product you buy from this brochure does not work right, Gast will repair or replace it once, at no charge, for up to one year from the date of shipment from the factory. In the course of repair or replacement, Gast may send you written recommendations on how to prevent a problem from happening again. Gast reserves the right to withdraw this warranty if you do not follow these recommendations. Customer is responsible for freight charges both to and from Gast in all cases. This warranty does not apply to electric motors, electrical controls, and gasoline engines, which Gast obtains from other manufacturers. A motor or engine carries only the warranty of the company that makes it.

THIS WARRANTY IS EXCLUSIVE AND IS IN LIEU OF ALL OTHER WARRANTIES, WHETHER WRITTEN, ORAL, OR IMPLIED, INCLUDING THE WARRANTY OF MERCHANTABILITY AND OF FITNESS FOR ANY PARTICULAR PURPOSE. GAST'S LIABILITY IS IN ALL CASES LIMITED TO THE REPLACEMENT PRICE OF ITS PRODUCT. GAST SHALL NOT BE LIABLE FOR ANY OTHER DAMAGES, WHETHER CONSEQUENTIAL, INDIRECT, OR INCIDENTAL, ARISING FROM THE SALE OR USE OF ITS PRODUCTS.

Gast's sales personnel may modify this warranty, but only by signing a specific, written description of any modifications.

## **Disclaimer**

The information presented in this electronic catalog is based on technical data and test results of nominal units. It is believed to be accurate and is offered as an aid in the selection of Gast products. It is the user's responsibility to determine suitability of the product for his intended use and the user assumes all risk and liability whatsoever in connection therewith.



# LOW PRESSURE GAUGES

Types 611.10 & 612.20

## PRICE LIST

Type 611.10 2 1/2" (63mm)  
 Type 612.20 4" (100mm)

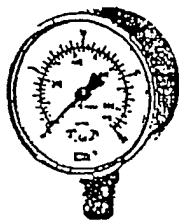

### Standard Features

- Case: Black painted steel (611.10)  
 Stainless steel (612.20)
- Bayonet Ring: None (2 1/2")  
 Stainless steel (4")
- Wetted Parts: Copper alloy
- Window: Acrylic (2 1/2")  
 Instrument glass (4")
- Dial: White aluminum
- Pointer: Black aluminum
- Accuracy: ± 1.5% of span

Brass movement with highly polished bearing surfaces

Recalibration screw on dial

### Special Order Options

50 pcs. minimum order quantity per line item required (611.10)  
 25 pcs. minimum order quantity per line item required (612.20)

Custom Dials - Special scales and dial markings are available. Standard list prices apply. Add any applicable artwork/set-up charges. Refer to "Custom Dial Artwork Charges" (price page PL95-32).

Special Connections - No additional charge for standard NPT or metric threads. Contact factory for other special threads.

Gauge Accessories - Additional accessories may be available. Refer to "Pressure Gauge Accessories" (price page PL95-30).

### Additional Options Available -

- Nickel or chrome plated connection
- Lower back mount (Type 612.20 only)
- Rear flange
- U-clamp
- Safety glass window
- Stainless steel wetted parts 2 1/2" (631.10)
- Stainless steel wetted parts 4" (632.50)
- (refer to price page PL95-21 for prices)
- Cleaned for oxygen service
- Stainless steel case and ring
- Red drag pointer

- \* Items with part numbers are available from stock (subject to prior sale).
- \* Please use applicable part numbers when ordering.
- \* Items shown without part numbers are available on special order at no additional charge. Above listed minimum order quantities per line item required. Contact factory for current lead times.

Type	611.10		612.20	
Size	2 1/2"		4"	
Connection	LM	CBM	LM	
Conn. Size	1/4" NPT			
Data Sheet	APM 06.01		APM 06.02	
List Price	\$43.25	\$47.55	\$139.15	
Vacuum Range (dual scale)				
	inch water	mm water		
	0-30	0-760	9852344	9851852 9747724
	0-60	0-1500	9748321	9748339
	0-100	0-2500	9747473	9747465
Pressure Ranges (dual scale)				
	inch water	mm water		
	0-15	0-380	9851682	9851860 9747732
	0-30	0-760	9851690	9855785 9747740
	0-60	0-1500	9851704	9803432 9747758
	0-100	0-2500	9851810	9851879 9747766
	0-200	0-5000	9851828	9851887 9747775
	oz/ sq. in.	mm water		
	0-10	0-440	9851771	
	0-15	0-660	9851780	
	0-20	0-880	9851798	
	0-30	0-1320	9851747	9851917
	0-35	0-1540	9851801	9857273
	0-60	0-2640	9851755	9803548
	oz/ sq. in.	in. water		
	0-20	0-34	9851720	9857281
	0-32	0-55	9851739	9855793
Pressure Ranges (single scale)				
	psi			
	3	9851925	9851836	9747783
	5	9851933	9851844	9747791
Accessories (installed)				
<small>Accessory prices do not apply to orders of 50 pcs or more per line item (25 pcs. for type 612.20). Contact factory for quote.</small>				
FF, chrome plated brass	\$27.55	\$21.55	N/A	
	1327085	1327087		
FF, black painted steel	\$21.30	\$24.55	N/A	
	1327089	1327091		
FF, stainless steel	--	--	\$23.65	
			1327081	
Restrictor, brass		\$ .90		
		1326943		

ABBREVIATIONS  
 LM - Lower Mount  
 CBM - Center Back Mount  
 FF - Front Flange  
 N/A - Not Available

In keeping with and for purposes of product improvement, Wika reserves the right to make design changes without prior notice.

Prices subject to change without notice.  
 This price list supersedes price list dated 01/01/95.  
 Effective 05/01/95 or  
 Price Page PL95-20

Prices: FOB Lawrenceville, GA  
 Terms: 30 days net  
 (subject to credit approval)

**APPENDIX B**

**DATA COLLECTION SHEETS**













**INTERIM RECORD DRAWINGS FOR  
EXPANDED BIOVENTING SYSTEM  
BUILDINGS 2034/2035  
FAIRCHILD AIR FORCE BASE**

**PREPARED FOR**

**AFCEE**

**JULY 1996**

**DRAWING INDEX**

<u>DRAWING NO</u>	<u>DRAWING NAME</u>
G-0.1	TITLE SHEET AND SITE LAYOUT
G-0.2	LEGEND AND STANDARD TRENCH DETAIL
G-0.3	VENT WELL AND MONITORING POINT STANDARD DETAILS
G-0.4	BLOWER P & ID
G-0.5	BLOWER PIPING LAYOUT DETAIL
G-0.6	BLOWER SHED FIELD INSTALLATION DETAIL AND BLOWER SHED CONSTRUCTION DETAIL

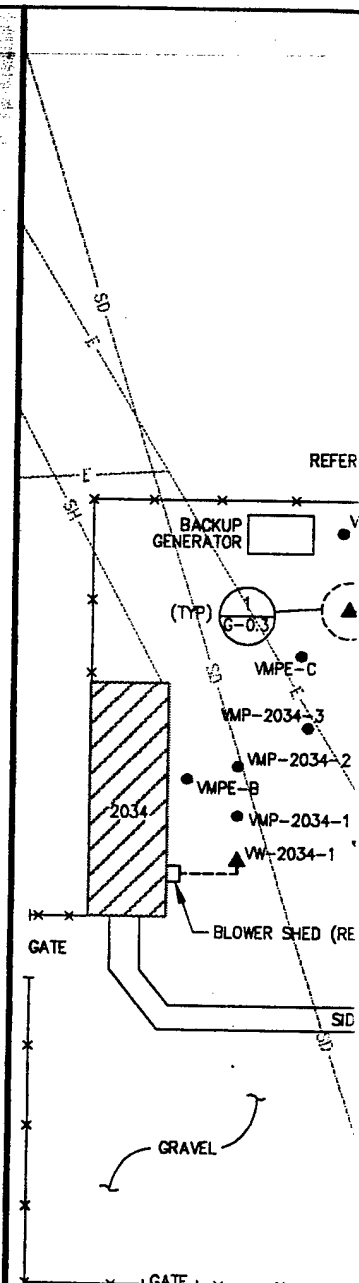

**SITE LAYOUT**

SCALE: 1" = 40'

NOTE: LOCATIONS OF UTILITIES A

①

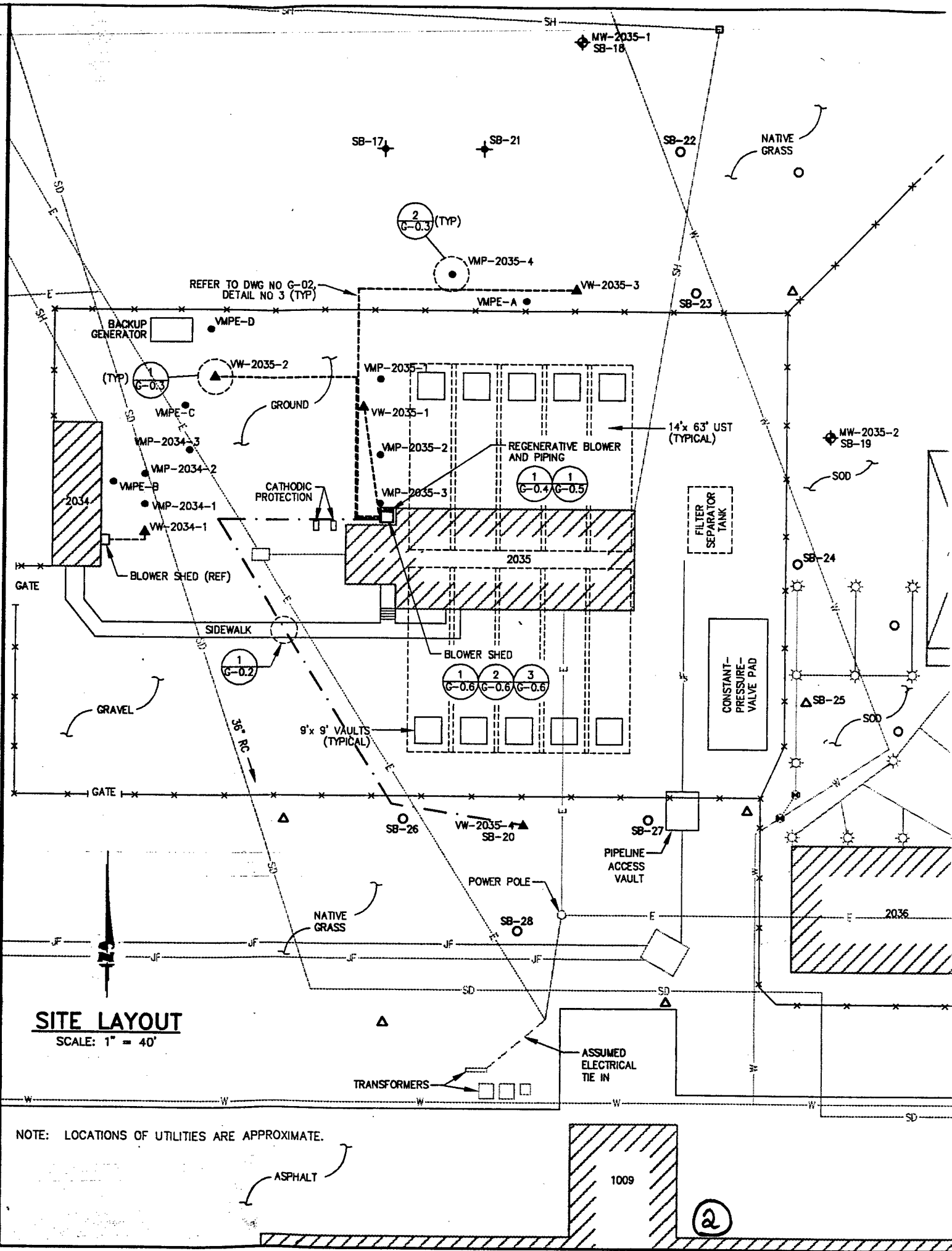

**SITE LAYOUT**  
SCALE: 1" = 40'

NOTE: LOCATIONS OF UTILITIES ARE APPROXIMATE.

2

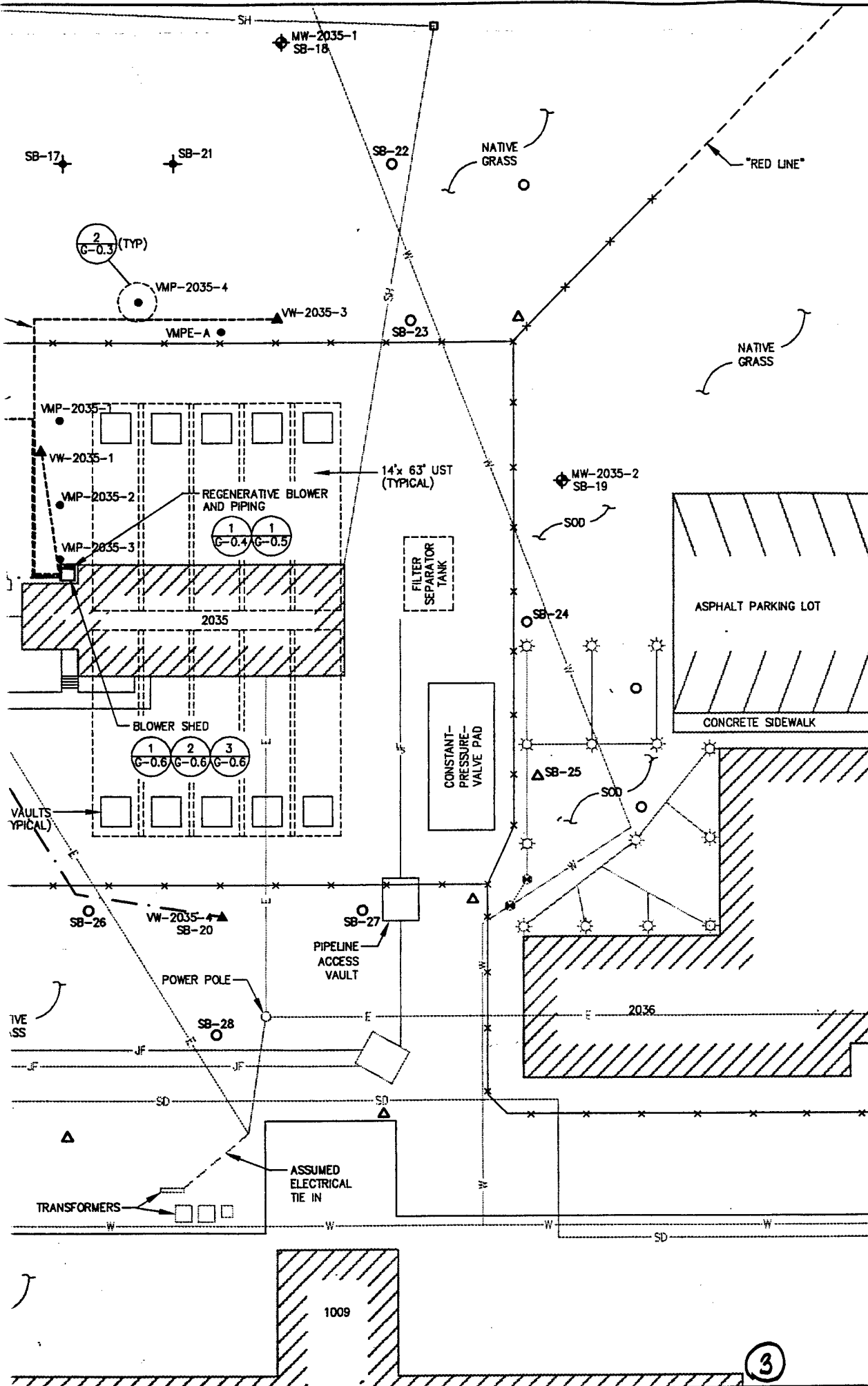

Job No. 726876.4042	By
Designed BRB	Date
Drawn MW	Rev
Checked	Date
Reviewed	Description
Approved	
Reg. No. 1	6/14/96
	INTERIA RECORD DRAWING

**PARSONS ENGINEERING SCIENCE, INC.**  
 Denver, Colorado  
 (303) 831-8100

**AIR FORCE CENTER FOR ENVIRONMENTAL EXCELLENCE (AFCEE)**  
 EXPANDED BIOVENTING SYSTEM BUILDINGS 2034/2035  
 FAIRCHILD AIR FORCE BASE

**TITLE SHEET AND SITE LAYOUT**

DRAWING NO	REV
<b>G-0.1</b>	<b>1</b>

3

# ABBREVIATIONS

AIJ	AIR INJECTION
APPROX	APPROXIMATE
ASTM	AMERICAN SOCIETY OF TESTING AND MATERIALS
&	AND
⊙	AT
CBM	CENTER BACK MOUNT
CLR	CLEAR
DIA	DIAMETER
EB	EXPLORATORY BORING
ECC	ECCENTRIC
EW	EACH WAY
FOT	FLAT ON TOP
FPT	FEMALE PIPE THREAD
FT	FOOT
GALV	GALVANIZED STEEL
ie	FOR EXAMPLE
LM	LOWER MOUNT
MAX	MAXIMUM
MIN	MINIMUM
MP	MONITORING POINT
MPT	MALE PIPE THREAD
NO, #	NUMBER
NPT	NATIONAL PIPE THREAD
NTS	NOT TO SCALE
OC	ON CENTER
OD	OUTSIDE DIAMETER
PVC	POLYVINYL CHLORIDE
PW	PROPOSED WELL
RED	REDUCER
REF	REFERENCE
SCH	SCHEDULE
S	SOCKET
SPVC	SLOTTED POLYVINYL CHLORIDE
ST STL	STAINLESS STEEL
TYP	TYPICAL
UST	UNDERGROUND STORAGE TANK
VW	VENT WELL
W/	WITH
WN	WELD NECK
WWF	WELDED WIRE FABRIC

# SYMBOLS

SB-21	⊕	SOIL BOREHOLE
VMP-2034-1	●	BIOVENTING MONITORING POINT
VW-2035-1	▲	VENT WELL
MW-2035-1	⊕	GROUNDWATER MONITORING WELL
	☼	SPRINKLER HEADS
	⊙	SPRINKLER VALVES
	□	MANHOLE/VAULT
	○	PROPOSED SOIL BOREHOLE POTENTIAL MONITORING POINT
	△	PROPOSED SOIL BOREHOLE POTENTIAL VENT WELL
---	---	HEADER PIPE TO VENT WELL
---	---	PROPOSED HEADER PIPE TO VENT WELL
-x-x-		FENCE
-E-		ELECTRICAL
-SD-		STORM DRAIN LINE
-W-		WATER LINE
-SH-		STEAM HEAT
-JF-		JET FUEL LINE

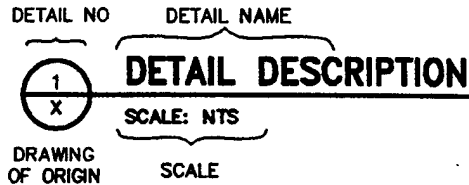
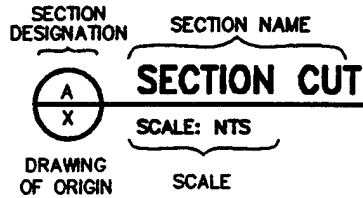

# MATERIAL LEGEND

	ASPHALT
	BENTONITE
	BENTONITE/CEMENT GROUT
	BENTONITE PELLETS
	BUILDING (EXISTING)
	COMPACTED BACKFILL
	COMPACTED BASE STONE
	CONCRETE
	PEA GRAVEL
	SAND
	UNDISTURBED SOIL

# PIPE MATERIAL

CS	CARBON STEEL
GALV	GALVANIZED STEEL
PVC	POLYVINYL CHLORIDE
SPVC	SCREENED POLYVINYL CHLORIDE

# PIPE SERVICE

AIJ	AIR INJECTION
BIV	BIOVENTING
DR	DRAIN

SAWCUT EXIST ( BOND NEW CON EXIST

EXISTING CONC SURF

PEA G



COMP/NATIVE













SECTION NAME  
**SECTION CUT**

SCALE: NTS  
SCALE

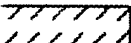
DETAIL NAME  
**DETAIL DESCRIPTION**

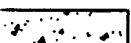
SCALE: NTS  
SCALE

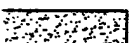
**MATERIAL LEGEND**

-  ASPHALT
-  BENTONITE
-  BENTONITE/CEMENT GROUT
-  BENTONITE PELLETS
-  BUILDING (EXISTING)
-  COMPACTED BACKFILL
-  COMPACTED BASE STONE
-  CONCRETE
-  PEA GRAVEL
-  SAND
-  UNDISTURBED SOIL

**PIPE MATERIAL**

- CARBON STEEL
- GALVANIZED STEEL
- POLYVINYL CHLORIDE
- SCREENED POLYVINYL CHLORIDE

**PIPE SERVICE**

- AIR INJECTION
- BIOVENTING
- DRAIN

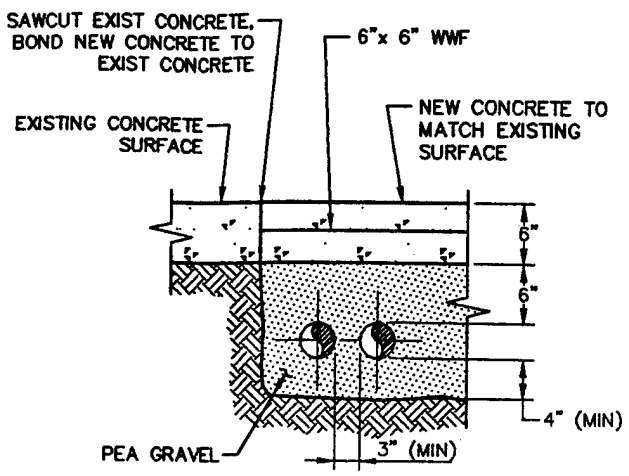

**CONCRETE REPLACEMENT DETAIL**  
SCALE: NTS

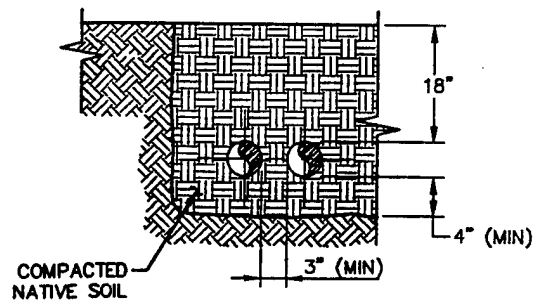

**SOIL COVER REPLACEMENT DETAIL**  
SCALE: NTS

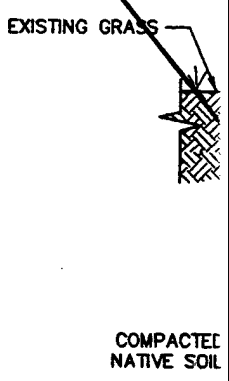



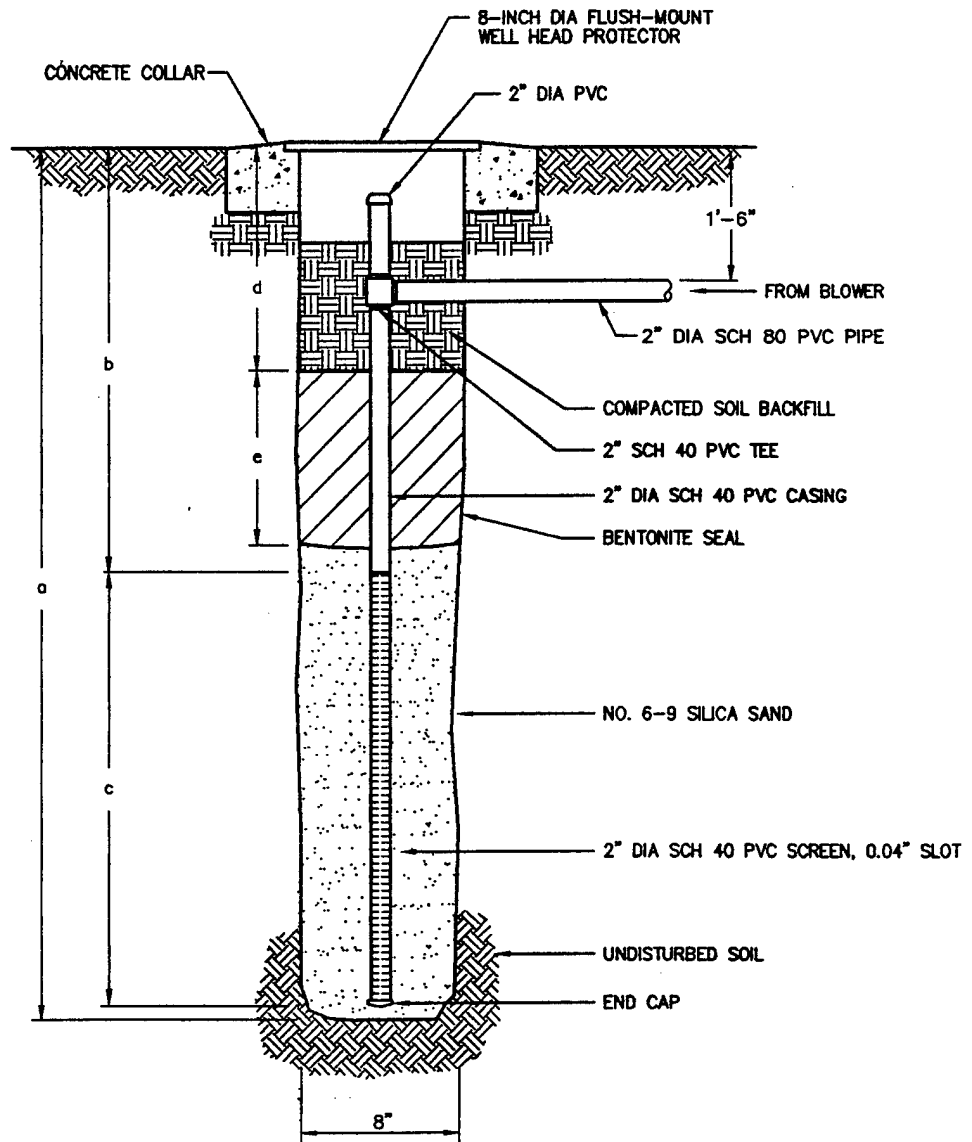

	VW-2035-2	VW-2035-3	VW-2035-4
a	15'-0"	15'-6"	15'-6"
b	5'-0"	5'-0"	5'-0"
c	9'-0"	10'-0"	10'-0"
d	2'-0"	2'-0"	1'-6"
e	2'-0"	2'-6"	2'-6"

1  
-  
VENT WELL (VW) DETAIL  
SCALE: NTS

NOTE:  
VW-2035-4 WAS NOT MANIFOLDED TO BLOWER. THEREFORE,  
THE 2" DIA SCH 80 PIPE AND THE 2" SCH 40 PVC TEE  
WILL BE INSTALLED ON THIS VENT WELL.

1

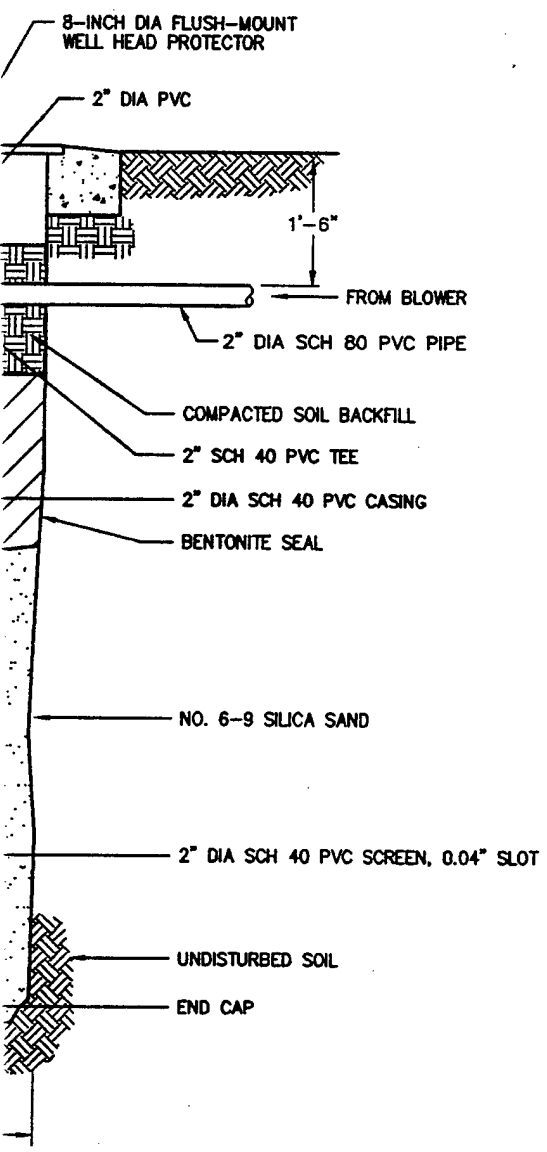

-3	VW-2035-4
	15'-6"
	5'-0"
	10'-0"
	1'-6"
	2'-6"

**W) DETAIL**

BLOWER. THEREFORE,  
SCH 40 PVC TEE

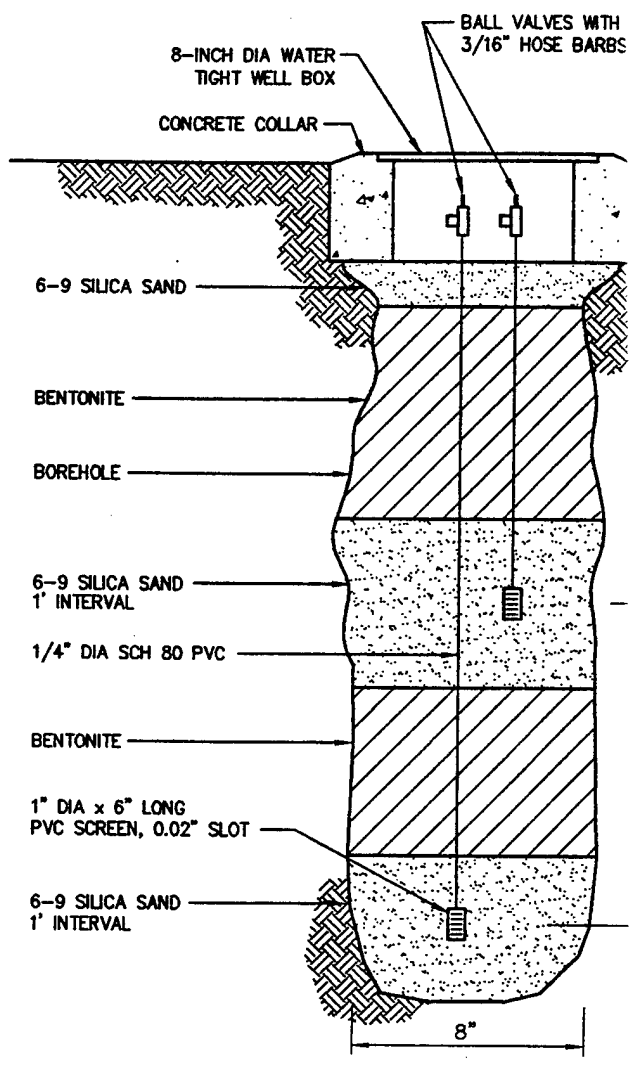

**2** MONITORING POINT (MF)  
SCALE: NTS

**2**



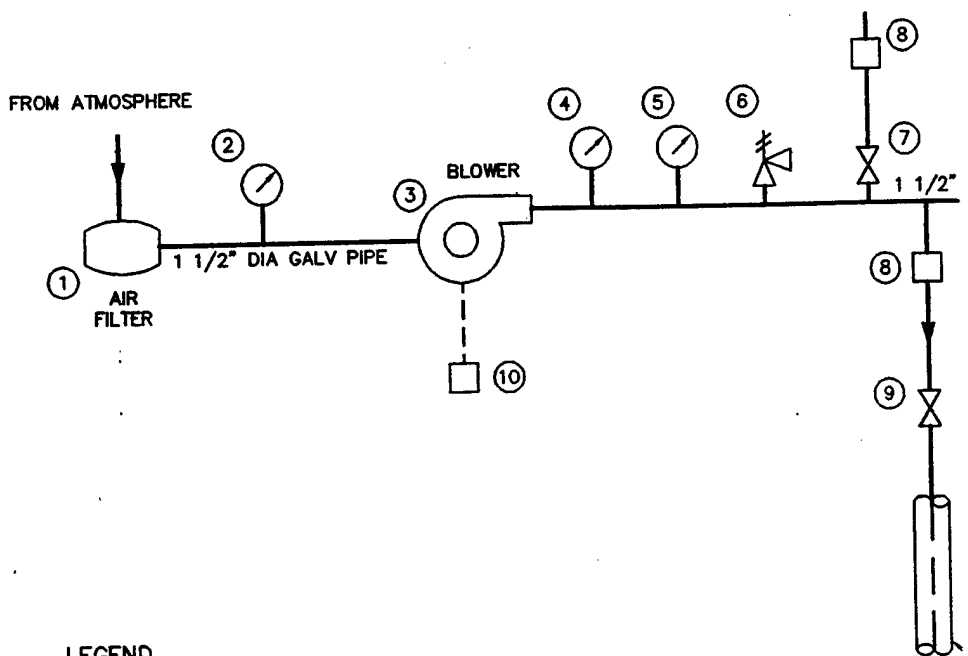

**LEGEND**

- ① INLET AIR FILTER - SOLBERG F-30P-150, REPLACEMENT ELEMENT 30P
- ② VACUUM GAUGE -GAST® AJ497, 2 1/2" DIA, 0-60" H<sub>2</sub>O, 1/4" NPT, LM
- ③ BLOWER - GAST® 2.0HP R5125Q-50, 92 CFM AT 30" H<sub>2</sub>O PRESSURE
- ④ TEMPERATURE GAUGE - ASHCROFT, 0-250F, 1/2" NPT, CBM (Part No. 2A606 FROM GRAINGER)
- ⑤ PRESSURE GAUGE - WKA 611.10, 2 1/2" DIA., 0-100" H<sub>2</sub>O, 1/4" NPT, LM (Part No. 9851810)
- ⑥ AUTOMATIC PRESSURE RELIEF VALVE - GAST® AG258, SET TO RELEASE AT 40" H<sub>2</sub>O PRESSURE
- ⑦ MANUAL PRESSURE RELIEF (BLEED) VALVE - 1 1/2" GATE
- ⑧ FLOW MEASURING PORT FITTED WITH PLUG (1/4" x 1/8" NPT BRASS REDUCING BUSHING, 1/8" NPT BRASS PLUG)
- ⑨ FLOW CONTROL VALVE - 1 1/2" GATE
- ⑩ DISCONNECT SWITCH



**BLOWER PIPING AND**



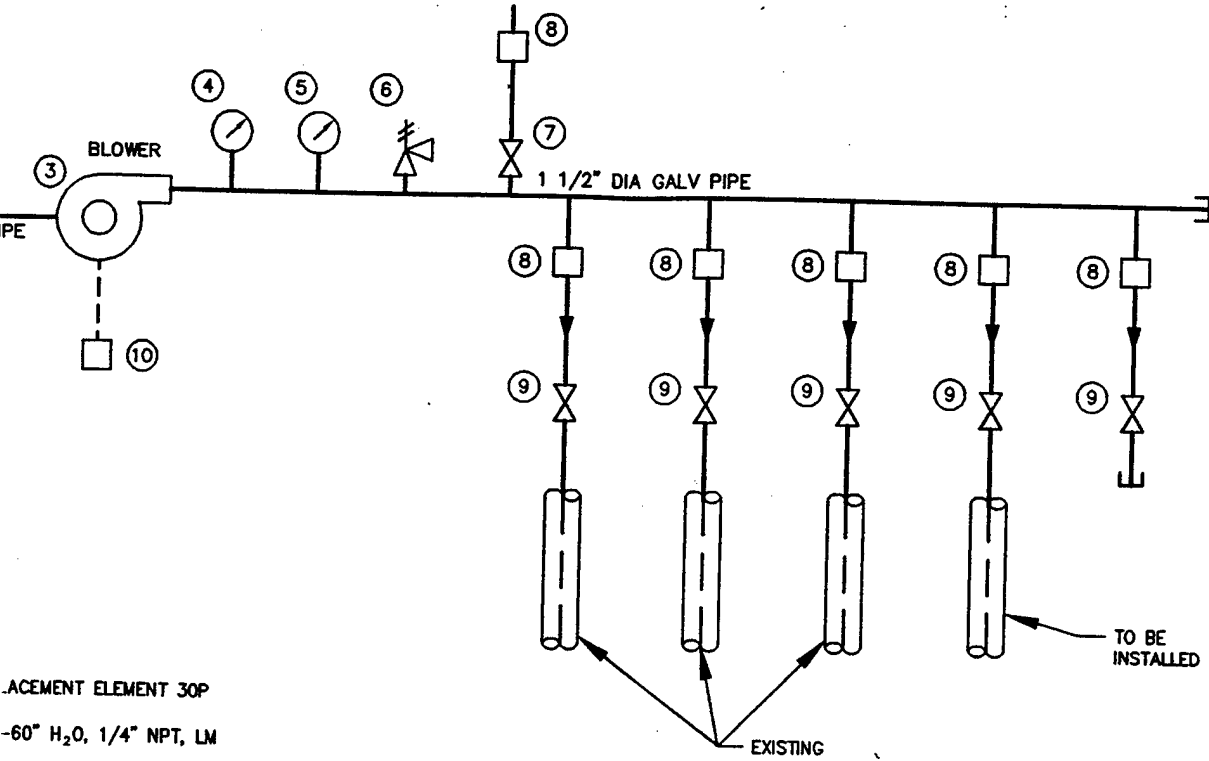

- ③ CEMENT ELEMENT 30P
- ④ -60° H<sub>2</sub>O, 1/4" NPT, LM
- ⑤ AT 30° H<sub>2</sub>O PRESSURE
- ⑥ 1/2" NPT, CBM
- ⑦ 0-100° H<sub>2</sub>O, 1/4" NPT, LM
- ⑧ G258, SET TO RELEASE AT 40° H<sub>2</sub>O PRESSURE
- ⑨ 1/2" GATE
- ⑩ x 1/8" NPT BRASS REDUCING BUSHING, 1/8" NPT BRASS PLUG)

1 BLOWER PIPING AND INSTRUMENTATION DIAGRAM  
SCALE: NTS

TION DIAGRAM

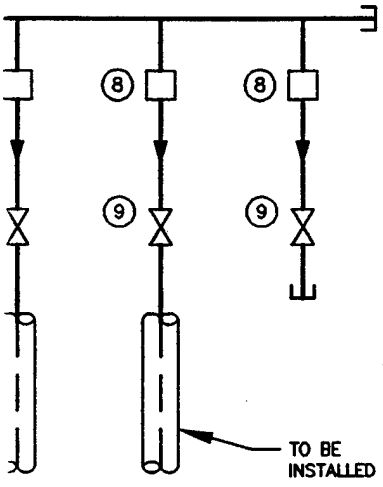

③

<b>PARSONS ENGINEERING SCIENCE, INC.</b> Denver, Colorado (303) 831-8100		<b>AIR FORCE CENTER FOR ENVIRONMENTAL EXCELLENCE (AFCEE)</b> EXPANDED BIOVENTING SYSTEM BUILDINGS 2034/2035 FAIRCHILD AIR FORCE BASE		Job No. 726876.40142 Designed BRB Drawn VW Checked Reviewed Approved Reg No Date		Rev 1 Date 6/14/96 Description INTERIM RECORD DRAWING	
<b>BLOWER P &amp; ID</b>		DRAWING NO <b>G-0.4</b>		REV <b>1</b>		By	

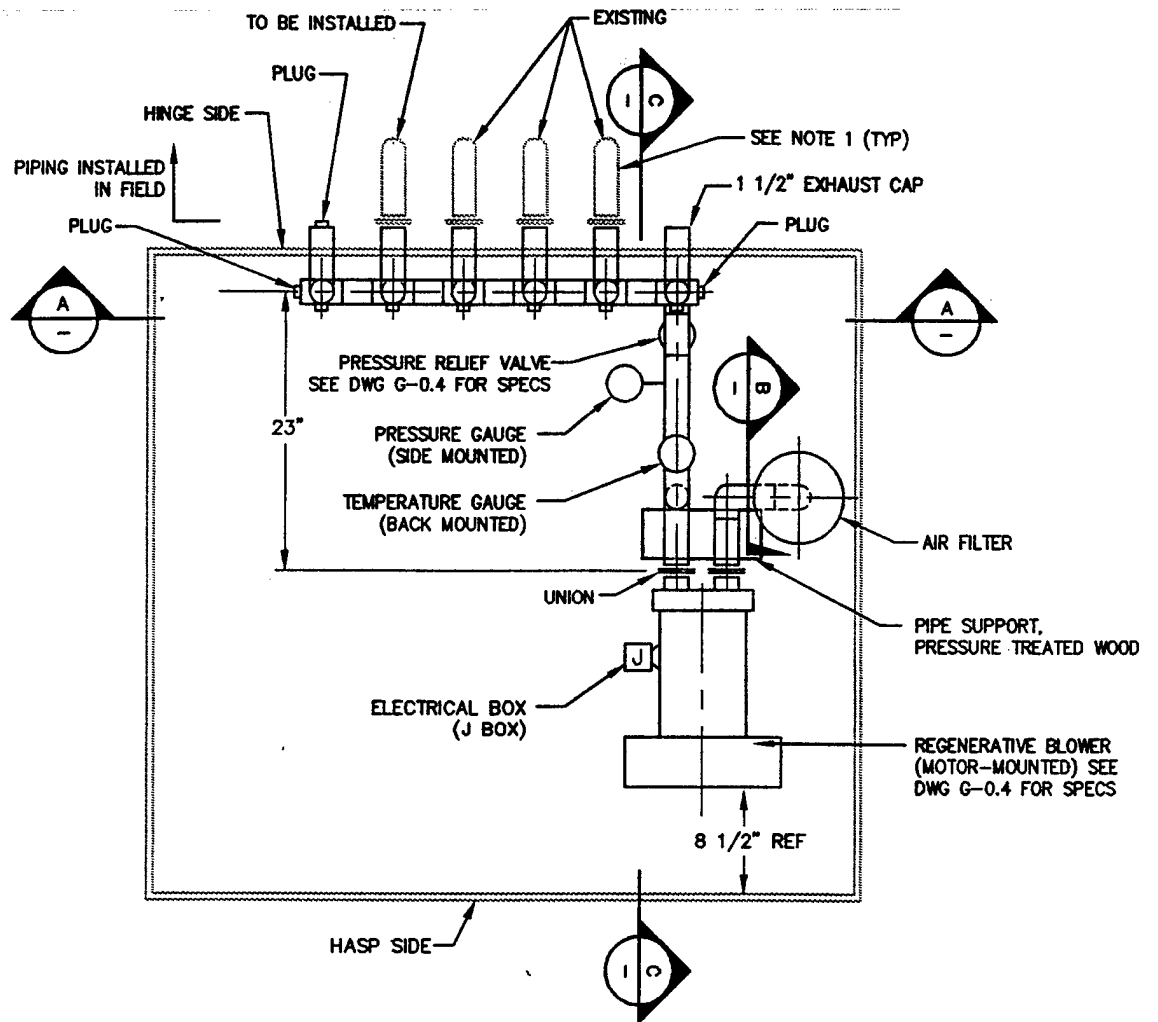

1 BLOWER PIPING LAYOUT PLAN DETAIL  
 3/4" = 1'-0"

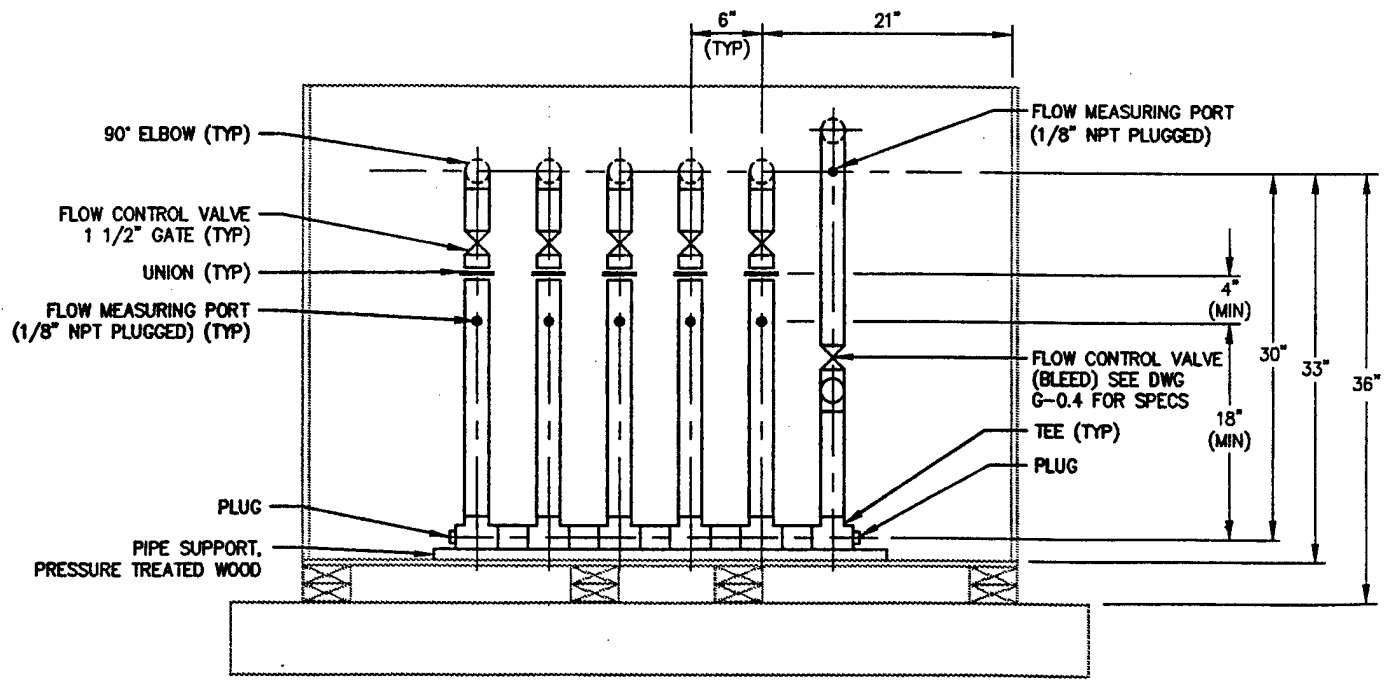

A MANIFOLD DETAIL SECTION  
 3/4" = 1'-0"

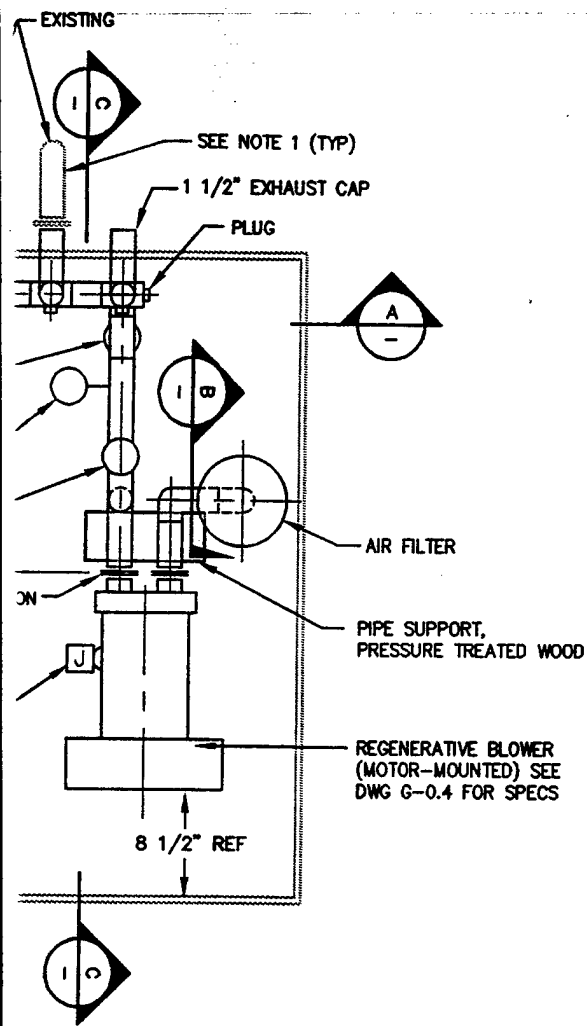

NOTES:

1. SHOP CORE HOLES TO PIPING DIMENSIONS
2. ALL PIPING 1 1/2" DIA. GALVANIZED STEEL, UNLESS OTHERWISE NOTED
3. SEE DRAWING G-0.6 FOR BLOWER BUILDING DETAILS

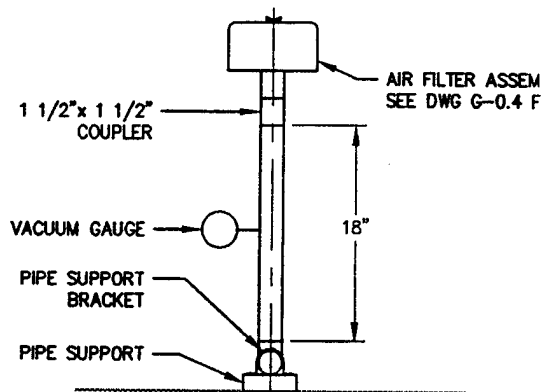

**B** BLOWER INLET PIPING SECT  
3/4" = 1'-0"

**IT PLAN DETAIL**

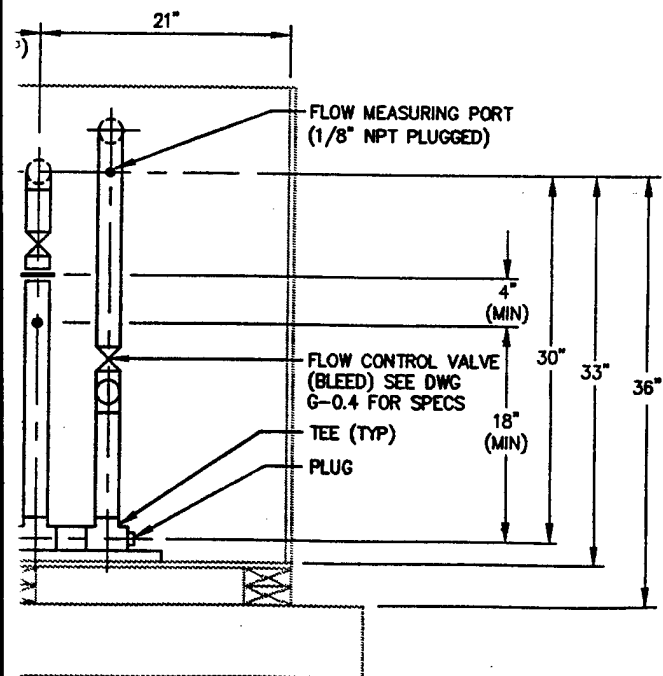

**I** SECTION

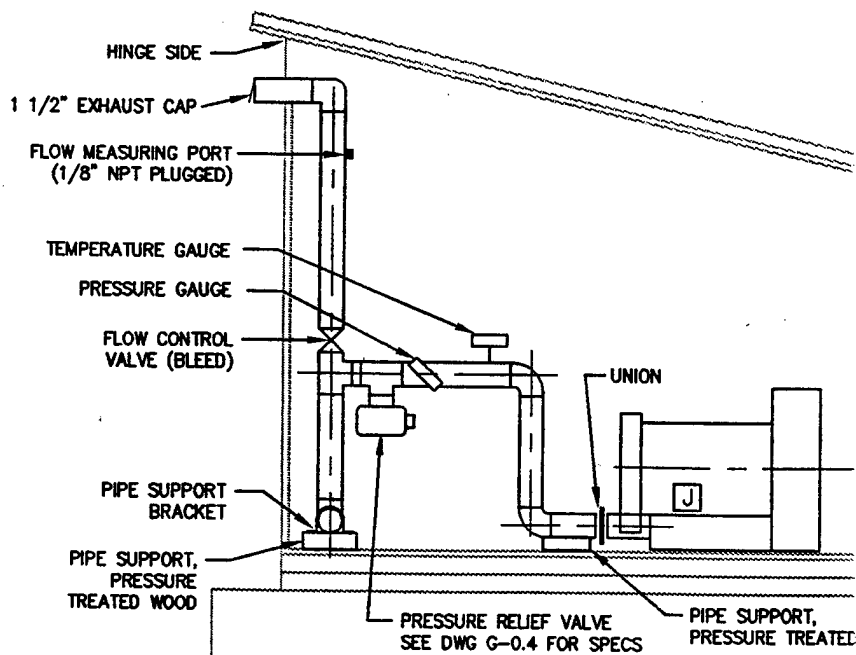

**C** BLOWER OUTLET PIPING SECT  
3/4" = 1'-0"

NOTES:

1. SHOP CORE HOLES TO PIPING DIMENSIONS
2. ALL PIPING 1 1/2" DIA. GALVANIZED STEEL, UNLESS OTHERWISE NOTED
3. SEE DRAWING G-0.6 FOR BLOWER BUILDING DETAILS

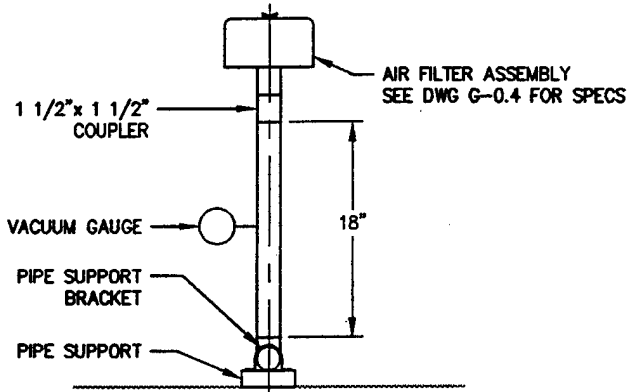

**B** **BLOWER INLET PIPING SECTION**  
 3/4" = 1'-0"

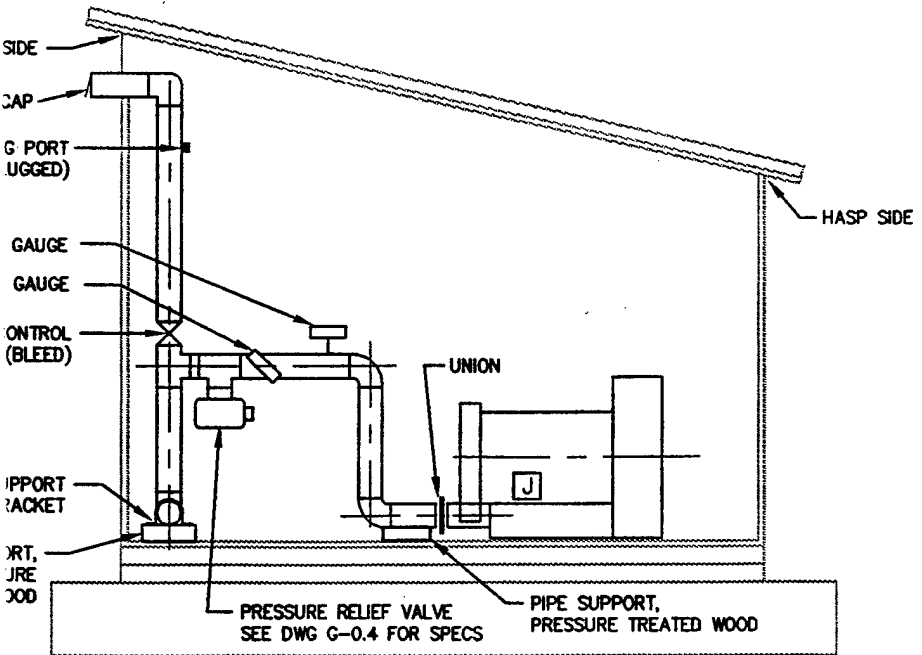

**C** **BLOWER OUTLET PIPING SECTION**  
 3/4" = 1'-0"

Job No. 728876-40142	By
Designed BRB	Date
Drawn MW	Rev
Checked	1 6/14/86
Reviewed	INTERIM RECORD DRAWING
Approved	Description
Reg No.	
Date	

**PARSONS ENGINEERING SCIENCE, INC.**  
 Denver, Colorado  
 (303) 831-8100

**AIR FORCE CENTER FOR ENVIRONMENTAL EXCELLENCE (AFCEE)**  
 EXPANDED BIOVENTING SYSTEM BUILDINGS 2034/2035  
 FAIRCHILD AIR FORCE BASE

**BLOWER PIPING LAYOUT DETAIL**

DRAWING NO	REV
<b>G-0.5</b>	<b>1</b>

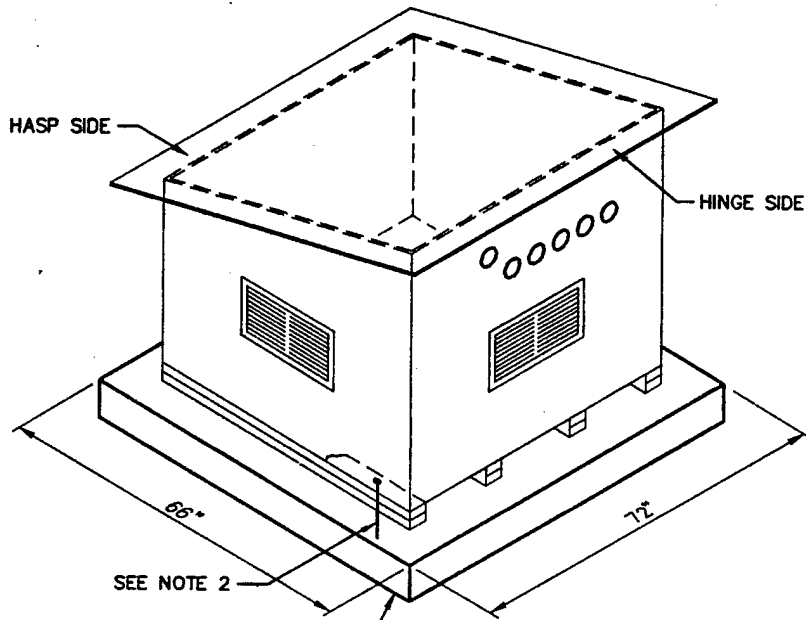

**NOTES:**

1. FIELD INSTALL BUILDING CENTRAL ON CONCRETE SLAB WITH ORIENTATION AS SHOWN
2. FIELD SECURE BLOWER SHED TO CONCRETE SLAB AT LOCATIONS BY THRU BOLTING. USE 3/8" x 6" LONG ST STL WEDGE ANCHOR BOLTS

CONCRETE SLAB;  
 6" THICK - 2500 PSI W/6" x 6" WWF  
 Poured on compacted or undisturbed  
 BASE - 1" x 45 CHAMFER TOP EDGE CONT.

1  
—

**BLOWER SHED FIELD INSTALLATION DETAIL**

NOT TO SCALE

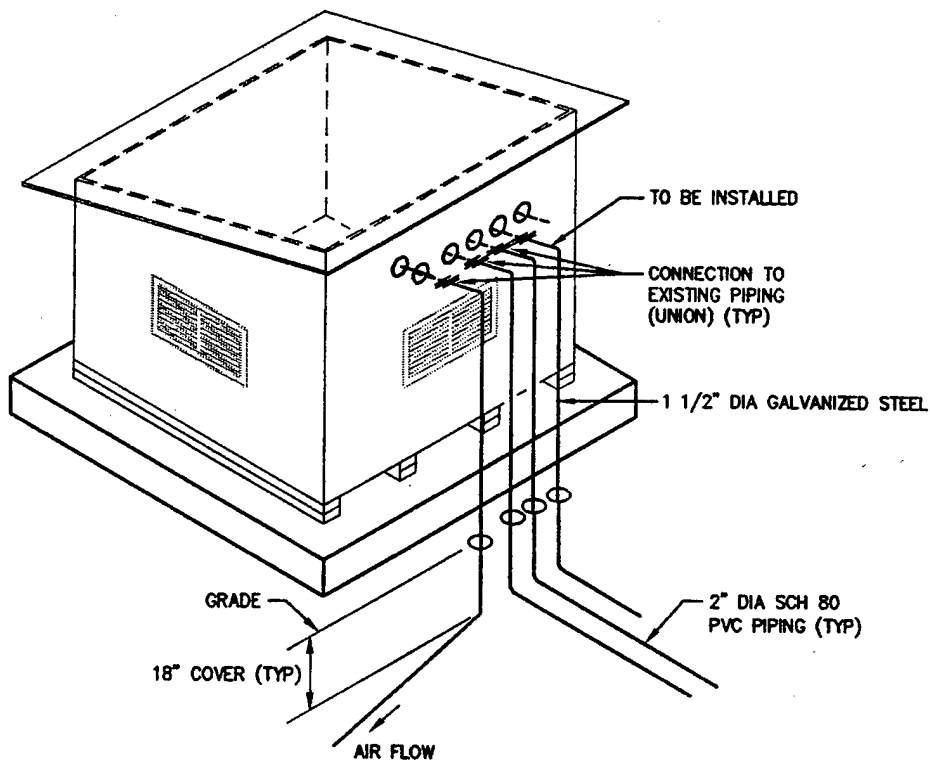

2  
—

**TYPICAL MANIFOLD DISCHARGE PIPING LAYOUT**

NOT TO SCALE

1

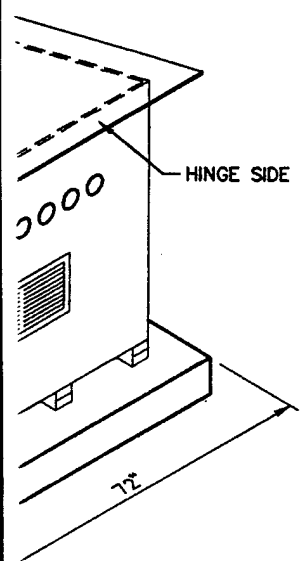

PSI W/6" x 6" WWF  
 ACTED OR UNDISTURBED  
 HAMFER TOP EDGE CONT.

INSTALLATION DETAIL

E INSTALLED

SECTION TO  
 ING PIPING  
 N) (TYP)

1/2" DIA GALVANIZED STEEL

2" DIA SCH 80  
 PVC PIPING (TYP)

E PIPING LAYOUT

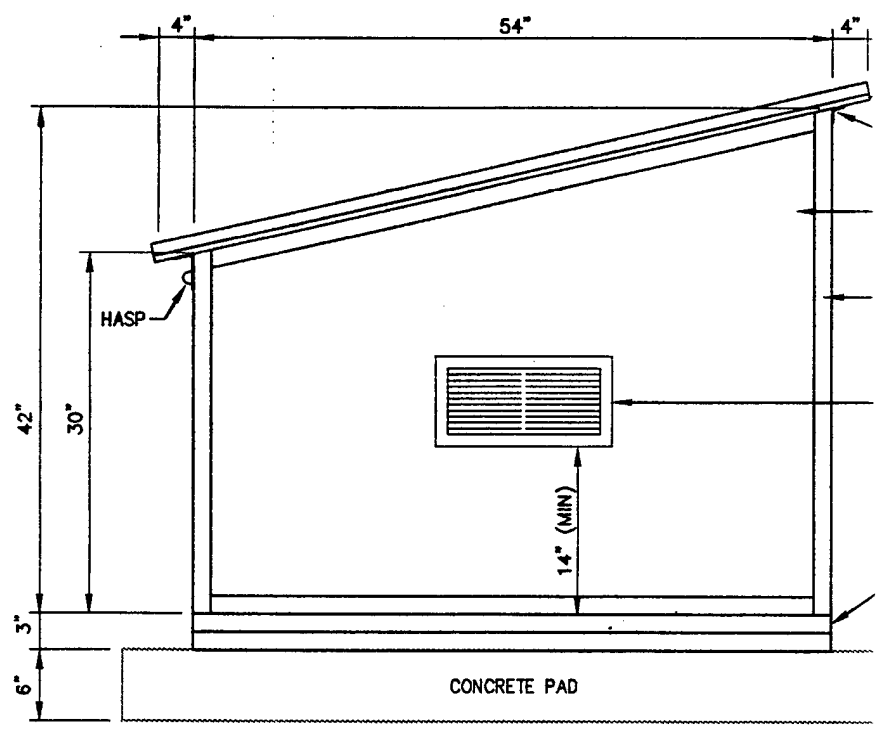

SIDE ELEVATION

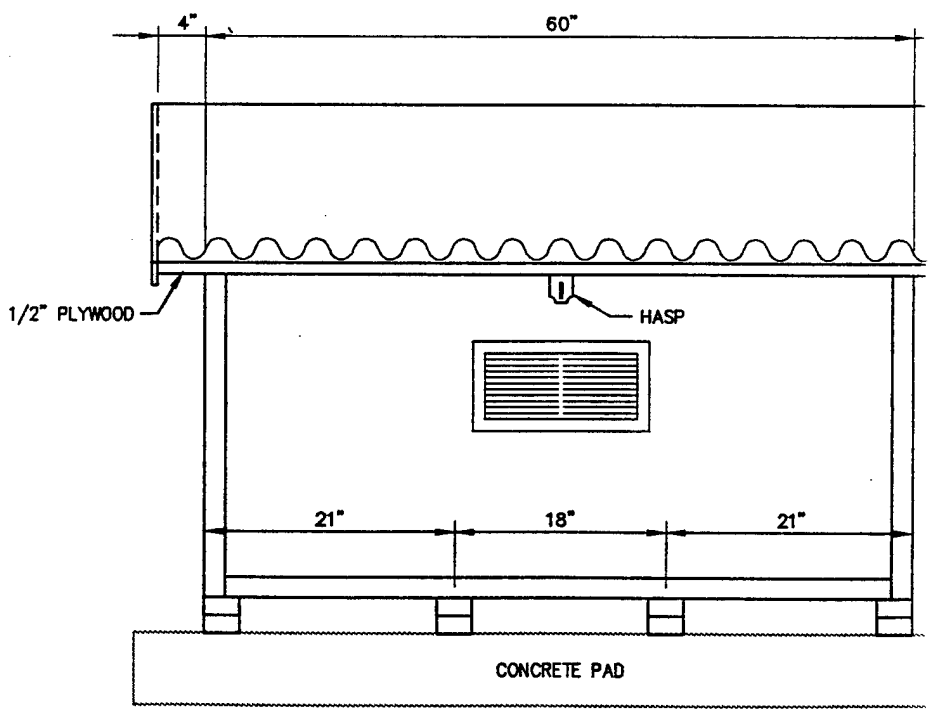

FRONT ELEVATION

- NOTES:
- 2" x 2" FRAME CONSTRUCTION
  - FLOOR CONSTRUCTED OF 3/4" EXTERIOR GRADE PLYWOOD
  - ROOF CONSTRUCTED OF 1/2" EXTERIOR GRADE PLYWOOD COVERED WITH PVC VINYL CORRUGATED ROOFING

BLOWER SHED CONSTRUCTION DETAIL

3

2

3/4" = 1'-0"

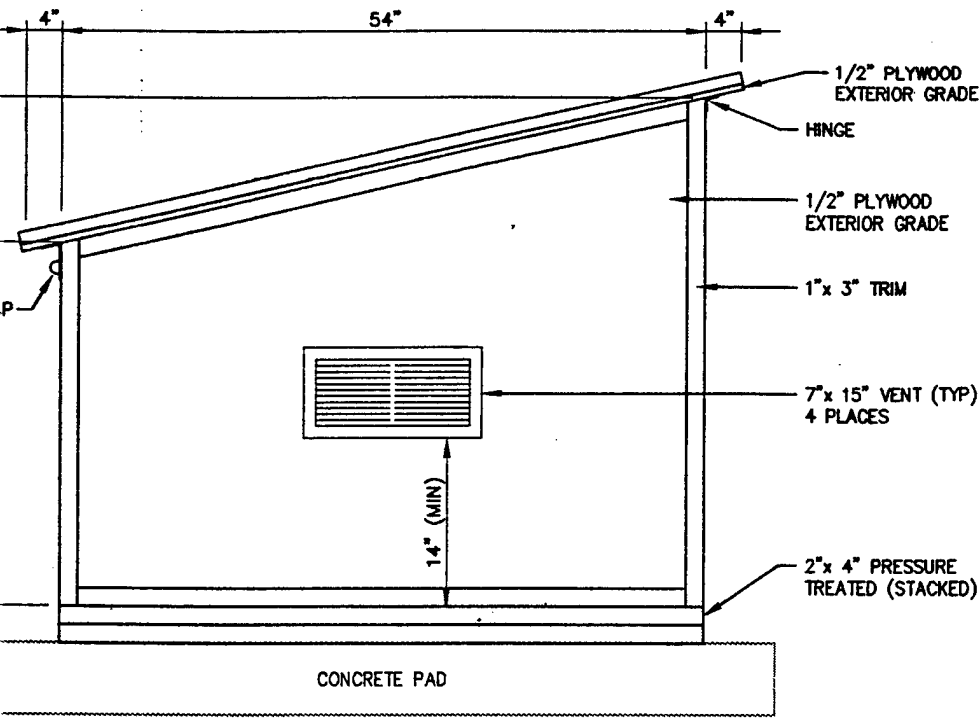

**SIDE ELEVATION**

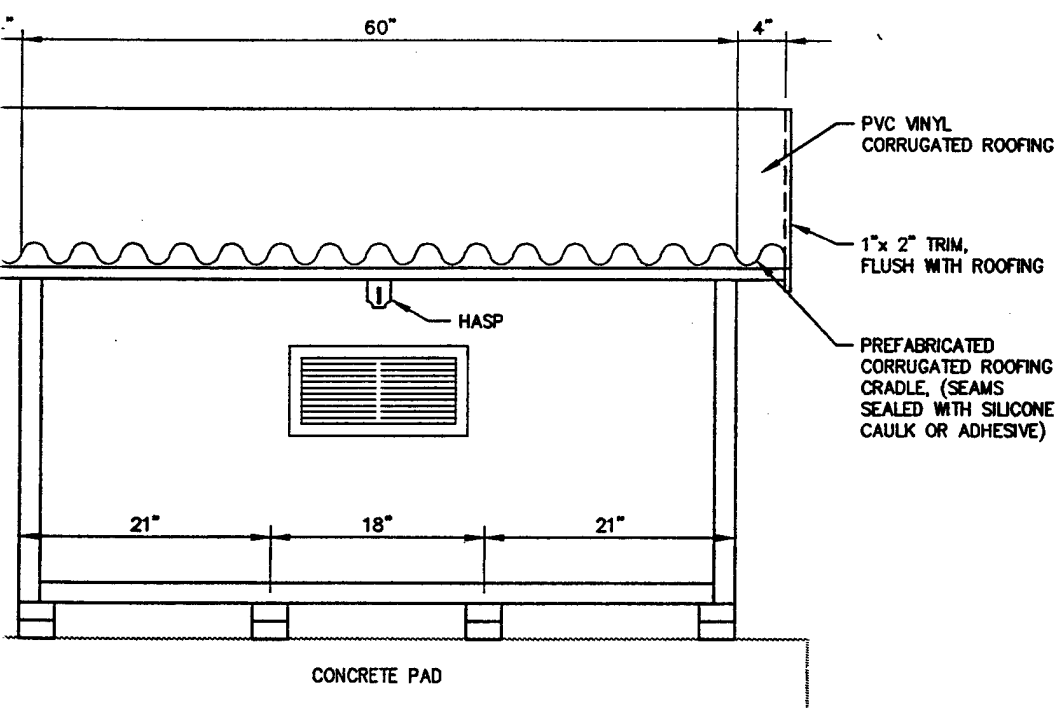

**FRONT ELEVATION**

**NOTES:**

1. 2"x 2" FRAME CONSTRUCTION
2. FLOOR CONSTRUCTED OF 3/4" EXTERIOR GRADE PLYWOOD
3. ROOF CONSTRUCTED OF 1/2" EXTERIOR GRADE PLYWOOD COVERED WITH PVC VINYL CORRUGATED ROOFING

**BLOWER SHED CONSTRUCTION DETAIL**

3/4" = 1'-0"

3

Job No. 728876.40142	Designed BRB	Drawn JMW	Checked	Reviewed	Approved	Reg No.	Date	Rev	Date	Description	By
							6/14/98	1		INTERIM RECORD DRAWING	

**PARSONS ENGINEERING SCIENCE, INC.**  
 Denver, Colorado  
 (303) 831-8100

**AIR FORCE CENTER FOR ENVIRONMENTAL EXCELLENCE (AFCEE)**  
 EXTENDED BIOVENTING TREATABILITY TEST BUILDINGS 2034/2035  
 FAIRCHILD AIR FORCE BASE

**BLOWER SHED FIELD INSTALLATION DETAIL AND BLOWER SHED CONSTRUCTION DETAILS**

DRAWING NO	REV
<b>G-0.6</b>	<b>1</b>

