

LOAN DOCUMENT

PHOTOGRAPH THIS SHEET

①

DTIC ACCESSION NUMBER

LEVEL

INVENTORY

Site-Specific Tech Rpt for Bioslu per...

DOCUMENT IDENTIFICATION

4 Oct 96

DISTRIBUTION STATEMENT A
Approved for Public Release
Distribution Unlimited

DISTRIBUTION STATEMENT

ACCESSION FOR	
NTIS	GRAN <input checked="" type="checkbox"/>
DTIC	TRAC <input type="checkbox"/>
UNANNOUNCED JUSTIFICATION	
BY	
DISTRIBUTION/	
AVAILABILITY CODES	
DISTRIBUTION	AVAILABILITY AND/OR SPECIAL
A-1	

DISTRIBUTION STAMP

DATE ACCESSIONED

DATE RETURNED

20001215 116

DATE RECEIVED IN DTIC

REGISTERED OR CERTIFIED NUMBER

PHOTOGRAPH THIS SHEET AND RETURN TO DTIC-FDAC

H
A
N
D
L
E

W
I
T
H

C
A
R
E

**SITE-SPECIFIC TECHNICAL REPORT
FOR BIOSLURPER TESTING AT
SITE SS-12, SEYMOUR JOHNSON AFB,
NORTH CAROLINA**

FINAL



PREPARED FOR:

**AIR FORCE CENTER FOR ENVIRONMENTAL EXCELLENCE
TECHNOLOGY TRANSFER DIVISION
(AFCEE/ERT)
8001 ARNOLD DRIVE
BROOKS AFB, TEXAS 78235-5357**

AND

SEYMOUR JOHNSON AFB, NC

4 OCTOBER 1996

AQM01-03-0558

DEFENSE TECHNICAL INFORMATION CENTER REQUEST FOR SCIENTIFIC AND TECHNICAL REPORTS

Title AFCEE Collection

1. Report Availability (Please check one box) <input checked="" type="checkbox"/> This report is available. Complete sections 2a - 2f. <input type="checkbox"/> This report is not available. Complete section 3.	2a. Number of Copies Forwarded	2b. Forwarding Date
	<u>each</u>	<u>July/2000</u>

2c. Distribution Statement (Please check ONE box)

DoD Directive 5230.24, "Distribution Statements on Technical Documents," 18 Mar 87, contains seven distribution statements, as described briefly below. Technical documents MUST be assigned a distribution statement.

DISTRIBUTION STATEMENT A: Approved for public release. Distribution is unlimited.

DISTRIBUTION STATEMENT B: Distribution authorized to U.S. Government Agencies only.

DISTRIBUTION STATEMENT C: Distribution authorized to U.S. Government Agencies and their contractors.

DISTRIBUTION STATEMENT D: Distribution authorized to U.S. Department of Defense (DoD) and U.S DoD contractors only.

DISTRIBUTION STATEMENT E: Distribution authorized to U.S. Department of Defense (DoD) components only.

DISTRIBUTION STATEMENT F: Further dissemination only as directed by the controlling DoD office indicated below or by higher authority.

DISTRIBUTION STATEMENT X: Distribution authorized to U.S. Government agencies and private individuals or enterprises eligible to obtain export-controlled technical data in accordance with DoD Directive 5230.25, Withholding of Unclassified Technical Data from Public Disclosure, 6 Nov 84.

2d. Reason For the Above Distribution Statement (in accordance with DoD Directive 5230.24)

2e. Controlling Office <u>HQ AFCEE</u>	2f. Date of Distribution Statement Determination <u>15 Nov 2000</u>
---	--

3. This report is NOT forwarded for the following reasons. (Please check appropriate box)

It was previously forwarded to DTIC on _____ (date) and the AD number is _____

It will be published at a later date. Enter approximate date if known. _____

In accordance with the provisions of DoD Directive 3200.12, the requested document is not supplied because:

Print or Type Name <u>Laura Peña</u>	Signature <u>Laura Peña</u>
Telephone <u>210-536-1431</u>	(For DTIC Use Only) AQ Number <u>M01-03-0558</u>

FINAL
SITE-SPECIFIC TECHNICAL REPORT (A003)

for

**BIOSLURPER TESTING AT SITE SS-12,
SEYMOUR JOHNSON AFB, NORTH CAROLINA**

by

A. Leeson, R. Gillespie, J. Kramer, and J.A. Kittel

for

**Mr. Patrick Haas
U. S. Air Force Center for Environmental Excellence
Technology Transfer Division
(AFCEE/ERT)
Brooks AFB, Texas 78235**

4 October 1996

**Battelle
505 King Avenue
Columbus, Ohio 43201-2693**

Contract No. F41624-94-C-8012

This report is a work prepared for the United States Government by Battelle. In no event shall either the United States Government or Battelle have any responsibility or liability for any consequences of any use, misuse, inability to use, or reliance upon the information contained herein, nor does either warrant or otherwise represent in any way the accuracy, adequacy, efficacy, or applicability of the contents hereof.

TABLE OF CONTENTS

LIST OF TABLES	ii
LIST OF FIGURES	ii
EXECUTIVE SUMMARY	iv
1.0 INTRODUCTION	1
1.1 Objectives	1
1.2 Testing Approach	2
2.0 SITE SS-12 SITE DESCRIPTION	3
3.0 BIOSLURPER SHORT-TERM PILOT TEST METHODS AT SITE SS-12	3
3.1 Initial LNAPL/Groundwater Measurements and Bardown Testing	3
3.2 Well Construction Details	3
3.3 Soil Gas Monitoring Point Construction Detail	6
3.4 Soil Sampling and Analysis	7
3.5 LNAPL Recovery Testing	7
3.5.1 System Setup	7
3.5.2 Initial Skimmer Pump Test	8
3.5.3 Bioslurper Pump Test	8
3.5.3.1 Bioslurper Pump Test at Monitoring Well MW-2	8
3.5.3.2 Bioslurper Pump Test at Monitoring Wells MW-1, MW-3, and MW-6	11
3.5.5 Drawdown Pump Test	11
3.5.6 Off-Gas Sampling and Analysis	13
3.5.7 Groundwater Sampling and Analysis	13
3.6 Soil Gas Permeability Testing	13
3.7 In Situ Respiration Testing	13
4.0 RESULTS AT SITE SS-12	14
4.1 Bardown Test Results	14
4.2 Soil Sample Analyses	17
4.3 LNAPL Pump Test Results	17
4.3.1 Initial Skimmer Pump Test Results	17
4.3.2 Bioslurper Pump Test Results	17
4.3.2.1 Bioslurper Pump Test Results at MW-2	17
4.3.2.2 Bioslurper Pump Test Results at MW-1, MW-3, and MW-6	22
4.3.3 Drawdown Pump Test	22
4.4 Extracted Groundwater and Off-Gas Analyses	22
4.5 Bioventing Analyses	24
4.5.1 Soil Gas Permeability and Radius of Influence	24
4.5.2 In Situ Respiration Test Results	24
5.0 DISCUSSION OF RESULTS AT SITE SS-12	28

6.0 REFERENCES	29
APPENDIX A: SITE-SPECIFIC TEST PLAN FOR BIOSLURPER FIELD ACTIVITIES AT SEYMOUR JOHNSON AFB, NC	A-1
APPENDIX B: LABORATORY ANALYTICAL REPORTS	B-1
APPENDIX C: SYSTEM CHECKLIST	C-1
APPENDIX D: DATA SHEETS FROM THE SHORT-TERM PILOT TEST	D-1
APPENDIX E: SOIL GAS PERMEABILITY TEST RESULTS	E-1
APPENDIX F: IN SITU RESPIRATION TEST RESULTS	E-1

LIST OF TABLES

Table 1. Initial Soil Gas Compositions at Site SS-12, Seymour Johnson AFB, NC	6
Table 2. Results of Baildown Testing in Monitoring Wells MW-1, MW-2, and MW-3 ...	15
Table 3. BTEX and TPH Concentrations in Soil Samples from Site SS-12, Seymour Johnson AFB, NC	20
Table 4. Physical Characterization of Soil from Site SS-12, Seymour Johnson AFB, NC	20
Table 5. Depths to Groundwater and LNAPL Prior to Each Pump Test at MW-2	21
Table 6. Pump Test Results at Site SS-12, Seymour Johnson AFB, NC	21
Table 7. Oxygen Concentrations During the Bioslurper Pump Test at Site SS-12, Seymour Johnson AFB, NC	23
Table 8. BTEX and TPH Concentrations in Extracted Groundwater During the Bioslurper Pump Test at Site SS-12, Seymour Johnson AFB, NC	23
Table 9. BTEX and TPH Concentrations in Off-Gas During the Bioslurper Pump Test at Site SS-12, Seymour Johnson AFB, NC	24
Table 10. BTEX Concentrations in LNAPL from Site SS-12, Seymour Johnson AFB, NC	27
Table 11. C-Range Compounds in LNAPL from Site SS-12, Seymour Johnson AFB, NC ..	27
Table 12. In Situ Respiration Test Results at Seymour Johnson AFB, NC	28

LIST OF FIGURES

Figure 1. Site Map Showing Monitoring Well Locations at Site SS-12, Seymour Johnson AFB, NC	4
Figure 2. Schematic Diagram Illustrating Construction Details of the Bioslurper Well and Soil Gas Monitoring Points at Site SS-12, Seymour Johnson AFB, NC	5
Figure 3. Slurper Tube Placement and Valve Position for the Skimmer Pump Test	9
Figure 4. Slurper Tube Placement and Valve Position for the Bioslurper Pump Test	10
Figure 5. Slurper Tube Placement and Valve Position for the Drawdown Pump Test	12
Figure 6. LNAPL Recovery Versus Time During Each Pump Test	18
Figure 7. LNAPL Recovery Rate Versus Time During the Bioslurper Pump Test	19

Figure 8.	Distribution of C-Range Compounds in Extracted LNAPL at Site 24, Edwards AFB, CA	25
Figure 9.	Soil Gas Pressure Change as a Function of Distance During the Soil Gas Permeability Test	26

EXECUTIVE SUMMARY

This report summarizes the field activities conducted at Seymour Johnson AFB, for a short-term field pilot test to compare vacuum-enhanced free-product recovery (bioslurping) to traditional free-product recovery techniques to remove light, nonaqueous-phase liquid (LNAPL) from subsurface soils and aquifers. The field testing at Seymour Johnson AFB is part of the Bioslurper Initiative, which is funded and managed by the U.S. Air Force Center for Environmental Excellence (AFCEE) Technology Transfer Division. The AFCEE Bioslurper Initiative is a multisite program designed to evaluate the efficacy of the bioslurping technology for (1) recovery of LNAPL from groundwater and the capillary fringe, and (2) enhancing natural in situ degradation of petroleum contaminants in the vadose zone via bioventing.

The main objective of the Bioslurper Initiative is to develop procedures for evaluating the potential for recovering free-phase LNAPL present at petroleum-contaminated sites. The overall study is designed to evaluate bioslurping and identify site parameters that are reliable predictors of bioslurping performance. To measure LNAPL recovery in a wide variety of in situ conditions, tests are being performed at many sites. The test at Seymour Johnson AFB is one of over 40 similar field tests to be conducted at various locations throughout the United States and its possessions.

The intent of field testing is to collect data to support determination of the predictability of LNAPL recovery and to evaluate the applicability, cost, and performance of the bioslurping technology for removal of free product and remediation of the contaminated area. The on-site testing is structured to allow direct comparison of the LNAPL recovery achieved by bioslurping with the performance of more conventional LNAPL recovery technologies. The test method included an initial site characterization followed by LNAPL recovery testing. The three LNAPL recovery technologies tested at Seymour Johnson AFB were skimmer pumping, bioslurping, and drawdown pumping.

Bioslurper pilot test activities were conducted at two locations at Site SS-12: (1) monitoring well MW-2, and (2) monitoring wells MW-1, MW-3, and MW-6. Site characterization activities were conducted to evaluate site variables that could affect LNAPL recovery efficiency and to determine the bioventing potential of the site. Testing included baildown testing to evaluate the mobility of LNAPL, soil sampling to determine physical/chemical site characteristics, soil gas permeability testing to determine the radius of influence, and in situ respiration testing to evaluate site microbial activity.

Following the site characterization activities, the pump tests were conducted. At monitoring well MW-2, pilot tests for skimmer pumping, bioslurping, and drawdown pumping were conducted. The LNAPL recovery testing was conducted in the following sequence at monitoring well MW-2: approximately 47 hours in the skimmer configuration, approximately 92 hours in the bioslurper configuration, and approximately 46 hours in the drawdown configuration.

After the drawdown pump test at MW-2, a bioslurper pump test was conducted at monitoring wells MW-1, MW-3, and MW-6 by connecting the monitoring wells with a polyvinyl chloride (PVC) manifold. The duration of the test was approximately 13 hours.

Measurements of extracted soil gas composition, LNAPL thickness, and groundwater level were taken throughout the testing. The volume of LNAPL recovered and groundwater extracted were quantified over time.

Overall, fuel recovery for all of the recovery technologies tested was low. Skimmer and drawdown pumping were not as effective as bioslurping at recovering LNAPL at this site; however, differences between the technologies was slight. Free product recovery rates were lower on average during skimmer and drawdown pumping, with average LNAPL recovery rates of 0.26 gallon/day during the skimmer pump test and 0.27 gallon/day during the drawdown pump test. LNAPL recovery rates during bioslurping were approximately 0.44 gallon/day.

Groundwater recovery rates during the bioslurper pump test were high in comparison to rates during the skimmer pump tests, but were comparable to recovery rates during the drawdown pump test. On average, groundwater was extracted at rates of 700 gallons/day during skimming, 1,700 gallons/day during bioslurping, and 1,300 gallons/day during drawdown pumping.

Soil gas concentrations were measured at monitoring points during the bioslurper test to determine whether the vadose zone was being oxygenated. Initial oxygen concentrations at MPA-5.0, MPB-4.0, and MPC-4.0 ranged from 13 to 17%, and would not be considered limiting to microbial biodegradation processes. As the bioslurper test progressed, oxygen concentrations decreased while carbon dioxide and TPH concentrations increased, possibly indicating the movement of oxygen-limited soil gas towards the bioslurping well. Over time, it is likely that the area would become well oxygenated.

Implementation of bioslurping at the Seymour Johnson AFB test site does not appear to be warranted based on the results of the short-term pilot test. Fuel recovery was low in all test configurations (skimming, bioslurper, and drawdown). Bioslurping resulted in a fuel recovery rate of 0.44 gallon/day which is only 0.20 gallon/day more than skimming produced. The pilot test results

indicate that LNAPL is not sufficiently mobile to facilitate significant recovery in the existing wells. It appears that recovery efforts beyond the current skimming system would be unlikely to increase fuel recovery results.

FINAL SITE-SPECIFIC TECHNICAL REPORT (A003)

for

BIOSLURPER TESTING AT SITE SS-12, SEYMOUR JOHNSON AFB, NORTH CAROLINA

4 October 1996

1.0 INTRODUCTION

This report describes activities performed and data collected during a field test at Seymour Johnson Air Force Base (AFB), North Carolina, to compare vacuum-enhanced free-product recovery (bioslurping) to traditional free-product recovery technologies for removal of light, nonaqueous-phase liquid (LNAPL) from subsurface soils and aquifers. The field testing at Seymour Johnson AFB is part of the Bioslurper Initiative, which is funded and managed by the U.S. Air Force Center for Environmental Excellence (AFCEE) Technology Transfer Division. The AFCEE Bioslurper Initiative is a multisite program designed to evaluate the efficacy of the bioslurping technology for (1) recovery of LNAPL from groundwater and the capillary fringe and (2) enhancing natural in situ degradation of petroleum contaminants in the vadose zone via bioventing.

1.1 Objectives

The main objective of the Bioslurper Initiative is to develop procedures for evaluating the potential for recovering free-phase LNAPL present at petroleum-contaminated sites. The overall study is designed to evaluate bioslurping and identify site parameters that are reliable predictors of bioslurping performance. To measure LNAPL recovery in a wide variety of in situ conditions, tests are being performed at many sites. The test at Seymour Johnson AFB is one of over 40 similar field tests to be conducted at various locations throughout the United States and its possessions. Aspects of the testing program that apply to all sites are described in the *Test Plan and Technical Protocol for Bioslurping* (Battelle, 1995). Test provisions specific to activities at Seymour Johnson AFB were described in the Site-Specific Test Plan provided in Appendix A.

The intent of field testing is to collect data to support determination of the predictability of LNAPL recovery and to evaluate the applicability, cost, and performance of the bioslurping

technology for removal of free product and remediation of the contaminated area. The on-site testing is structured to allow direct comparison of the LNAPL recovery achieved by bioslurping with the performance of more conventional LNAPL recovery technologies. The test method included an initial site characterization followed by LNAPL recovery testing. The three LNAPL recovery technologies tested at Seymour Johnson AFB were skimmer pumping, bioslurping, and drawdown pumping. The specific test objectives, methods, and results for the Seymour Johnson AFB test program are discussed in the following sections.

1.2 Testing Approach

Bioslurper pilot test activities were conducted at two locations at Site SS-12: (1) monitoring well MW-2, and (2) monitoring wells MW-1, MW-3, and MW-6. Site characterization activities were conducted to evaluate site variables that could affect LNAPL recovery efficiency and to determine the bioventing potential of the site. Testing included baildown testing to evaluate the mobility of LNAPL, soil sampling to determine physical/chemical site characteristics, soil gas permeability testing to determine the radius of influence, and in situ respiration testing to evaluate site microbial activity.

Following the site characterization activities, the pump tests were conducted. At monitoring well MW-2, pilot tests for skimmer pumping, bioslurping, and drawdown pumping were conducted. The LNAPL recovery testing was conducted in the following sequence at monitoring well MW-2: approximately 47 hours in the skimmer configuration, approximately 92 hours in the bioslurper configuration, and approximately 46 hours in the drawdown configuration.

After the drawdown pump test at MW-2, a bioslurper pump test was conducted at monitoring wells MW-1, MW-3, and MW-6 by connecting the monitoring wells with a polyvinyl chloride (PVC) manifold. The duration of the test was approximately 13 hours.

Measurements of extracted soil gas composition, LNAPL thickness, and groundwater level were taken throughout the testing. The volume of LNAPL recovered and groundwater extracted were quantified over time.

2.0 SITE SS-12 SITE DESCRIPTION

Site SS-12 is part of the SAC Flight Line Fuel Hydrant System and is located at Pump House #3 (Building 4553). Figure 1 shows existing wells at Site SS-12. Contamination at the site is generally associated with JP-4 jet fuel. Depth to ground water is approximately 5 to 7 ft. According to measurements taken in February 1995, free product was observed in monitoring wells MW-1, MW-2, MW-3, MW-5, and MW-6. The greatest thickness was observed in MW-2, where nearly 2 ft of free product was measured.

3.0 BIOSLURPER SHORT-TERM PILOT TEST METHODS AT SITE SS-12

This section documents the initial conditions at the test site and describes the test equipment and methods used for the short-term pilot test at Seymour Johnson AFB.

3.1 Initial LNAPL/Groundwater Measurements and Baildown Testing

Monitoring wells MW-1, MW-2, and MW-3 were evaluated for use in the bioslurper pilot testing. Initial depths to LNAPL and to groundwater were measured using an oil/water interface probe (ORS Model #1068013). LNAPL was removed from the well with a Teflon™ bailer until the LNAPL thickness could no longer be reduced. The rate of increase in the thickness of the floating LNAPL layer at the three monitoring wells was monitored for approximately 14 hours using the oil/water interface probe.

3.2 Well Construction Details

Existing monitoring well MW-2 was selected for the primary bioslurper pilot testing, while monitoring wells MW-1, MW-3, and MW-6 were used for a short-term bioslurper pump test. The monitoring wells were constructed of 2-inch-diameter PVC, with a total depth of approximately 15 ft and 10 ft of screen. A schematic diagram illustrating well construction details of monitoring well MW-2 is provided in Figure 2. Specific construction diagrams for the monitoring wells are provided in the Test Plan in Appendix A.

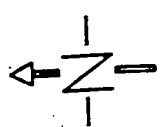

LEGEND

- DRAINAGE DITCH
- MW-9 PROPOSED MONITORING WELL LOCATIONS
- MW-2 EXISTING MONITORING WELL LOCATIONS
- JP-4 UNDERGROUND FUEL DELIVERY LINE
- V UNDERGROUND WATER LINE
- E UNDERGROUND ELECTRIC LINE TO PUMP
- RF UNDERGROUND RECOVERED FUEL LINE
- ⇒⇒ GROUND WATER FLOW

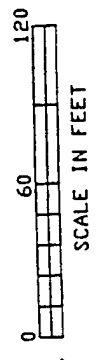
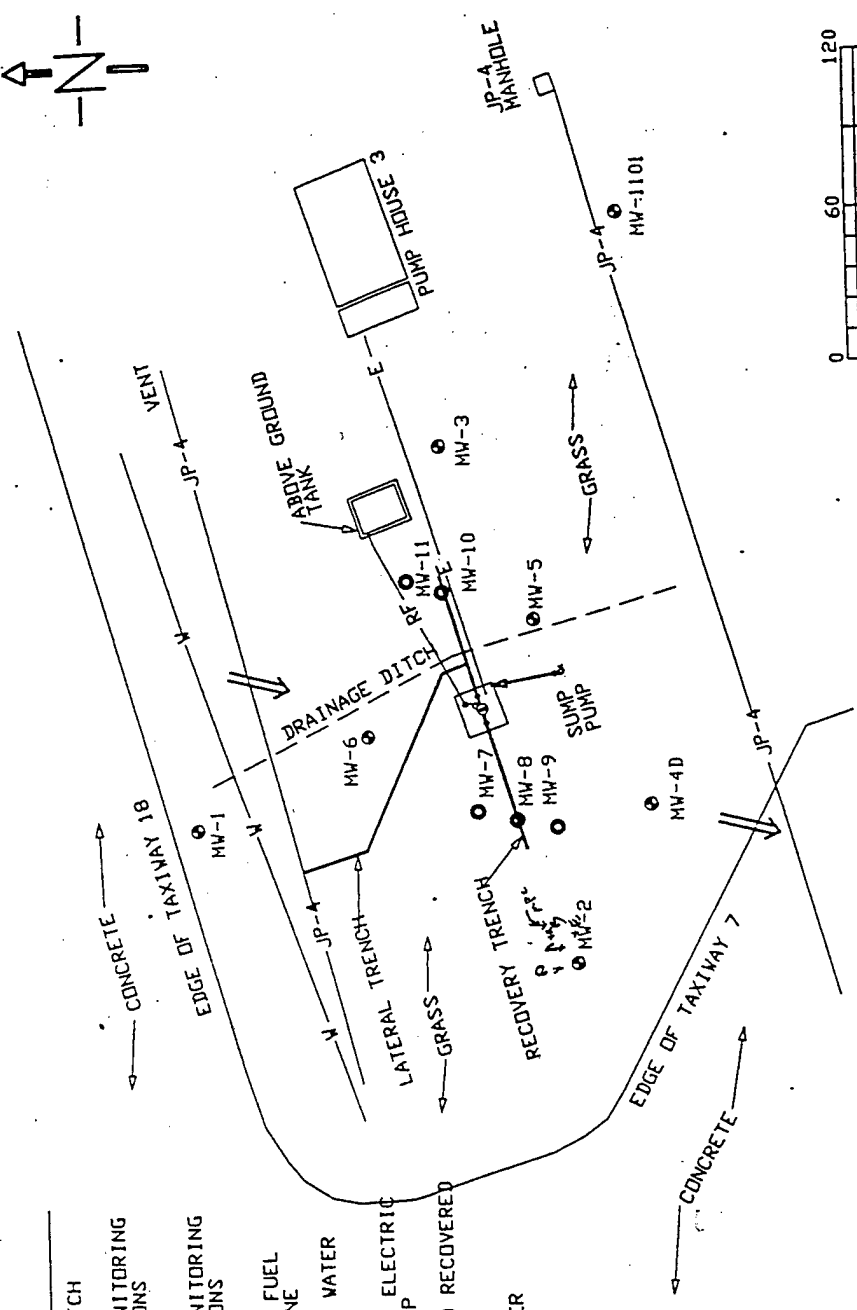

SOURCE: IT, 1993

Figure 1. Site Map Showing Monitoring Well Locations at Site SS-12, Seymour Johnson AFB, NC

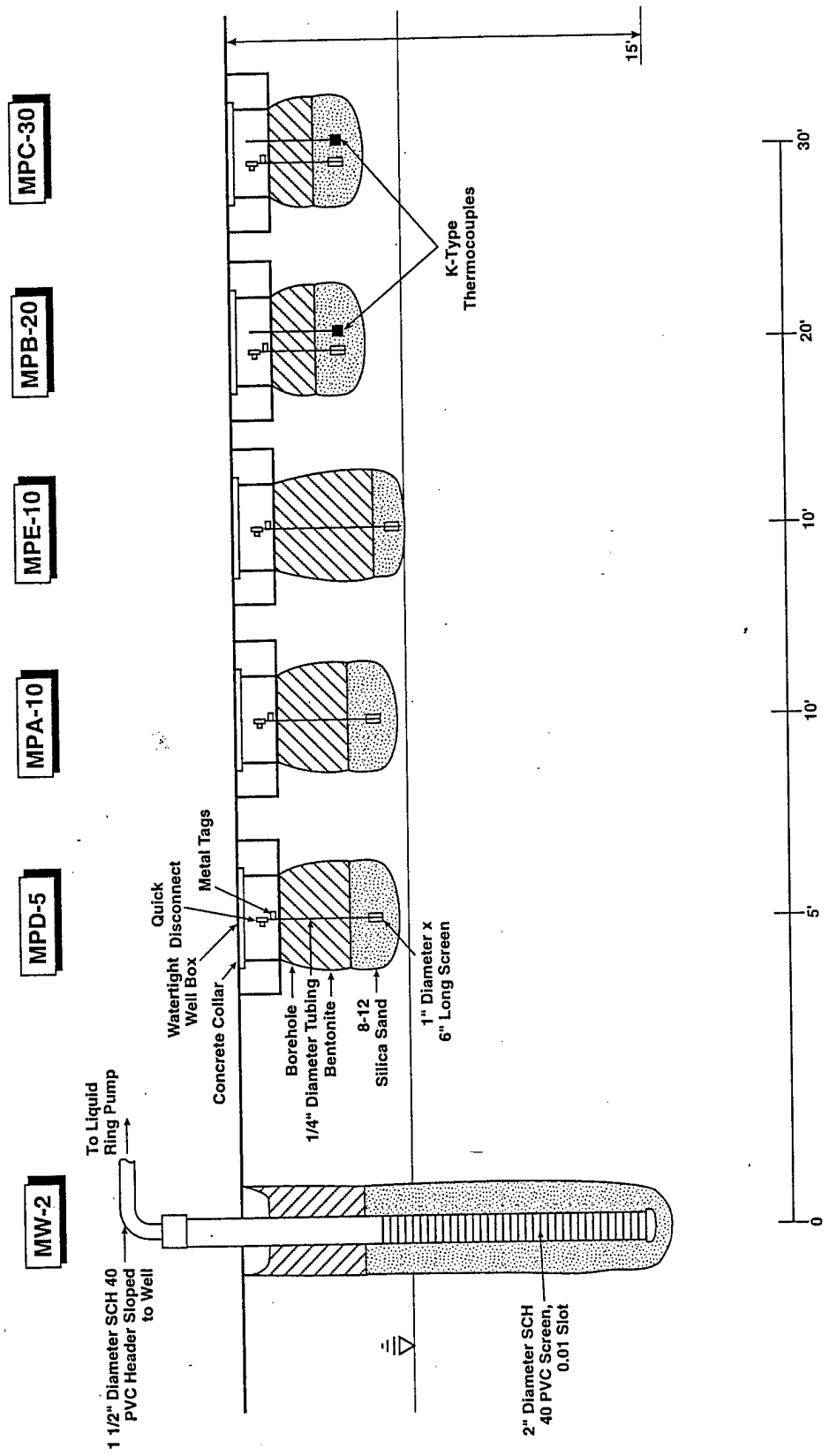

Fileson64-1

Figure 2. Schematic Diagram Illustrating Construction Details of the Bioslurper Well and Soil Gas Monitoring Points at Site SS-12, Seymour Johnson AFB, NC

3.3 Soil Gas Monitoring Point Construction Detail

Five soil gas monitoring points were installed in the area of monitoring well MW-2. The soil gas monitoring points were located 5, 10, 20, and 30 ft from MW-2 and were identified by Battelle as MPA, MPB, MPC, MPD, and MPE. Distance from vent well and construction details are illustrated in Figure 2.

The monitoring points consisted of ¼-inch tubing, with 1-inch-diameter, 6-inch-long screened areas. The screened lengths were positioned at the appropriate depth, and the annular space corresponding to the screened length was filled with silica sand. The space from the top of the screened length to the ground surface was filled with bentonite clay chips. After placement, the bentonite clay was hydrated with water to expand the chips and provide a seal.

All monitoring points were installed in a 6-inch-diameter borehole. Screened lengths were placed at the following depths: 4.5 to 5.0 ft in MPA; 3.5 to 4.0 ft in MPB; 3.5 to 4.0 ft in MPC; 4.5 to 5.0 ft in MPD; and 5.5 to 6.0 ft in MPE. Thermocouples were installed with monitoring points MPB-4.0 and MPC-4.0.

After installation of the monitoring points, initial soil gas measurements were taken with a GasTector portable O₂/CO₂ meter and a GasTech Trace-Tector portable hydrocarbon meter. Significant oxygen limitation was not observed, with oxygen concentrations ranging from 13 to 17% (Table 1).

Table 1. Initial Soil Gas Compositions at Site SS-12, Seymour Johnson AFB, NC

Monitoring Point ¹	Depth (ft)	Oxygen (%)	Carbon Dioxide (%)	TPH (ppmv)
MPA	5.0	13.0	2.0	> 10,000
MPB	4.0	17.0	3.0	2,000
MPC	4.0	17.0	1.5	60

¹ Initial soil gas concentrations were not obtained at monitoring points MPD or MPE, because these monitoring points were installed after the pump tests were initiated.

3.4 Soil Sampling and Analysis

Two soil samples were collected during installation of the soil gas monitoring points. The soil samples were collected in brass sleeves with a hand auger used to drill the monitoring points. The samples were labeled as follows: SJ-S-MPA-5.0' and SJ-S-MPD-5.5'. The samples were placed in insulated coolers, chain-of-custody records and shipping papers were completed, and the samples were sent to Alpha Analytical, Inc., in Sparks, Nevada by overnight express. Samples were analyzed for benzene, toluene, ethylbenzene, and xylenes (BTEX), bulk density, moisture content, particle size, and TPH. Laboratory analytical reports are provided in Appendix B.

3.5 LNAPL Recovery Testing

3.5.1 System Setup

The bioslurping pilot test system is a trailer-mounted mobile unit. The vacuum pump (Atlantic Fluidics Model A100, 7.5-hp liquid ring pump), oil/water separator, and required support equipment were carried to the test location on a trailer. The trailer was located near Pumphouse #3, the well cap was removed, a coupling and tee were attached to the top of the well, and the slurper tube was lowered into the well. The slurper tube was attached to the vacuum pump. Different configurations of the tee and the placement depth of the slurper tube allow for simulation of skimmer pumping, operation in the bioslurping configuration, or simulation of drawdown pumping as described in Sections 3.5.2, 3.5.3, and 3.5.5, respectively.

Vapor emissions were discharged directly to the atmosphere for these short-term tests. After treatment through the oil/water separator, groundwater was transferred to a 1,500 gallon polyethylene storage tank where it was stored until disposal at the Base Sanitary Sewer.

A brief system startup test was performed prior to LNAPL recovery testing to ensure that all system components were working properly. The system checklist is provided in Appendix C. All site data and field testing information were recorded in a field notebook and then transcribed onto pilot test data sheets provided in Appendix D.

3.5.2 Initial Skimmer Pump Test

Prior to test initiation, depths to LNAPL and groundwater were measured. The slurper tube was then set at the LNAPL/groundwater interface with the wellhead open to the atmosphere via a PVC connecting tee (Figure 3). The liquid ring pump and oil/water separator were primed with known amounts of groundwater to ensure that any LNAPL or groundwater entering the system could be quantified. The flow totalizers for the LNAPL and aqueous effluent were zeroed, and the liquid ring pump was started on June 13, 1996, to begin the skimmer pump test. The test was operated continuously for approximately 48 hours. The LNAPL and groundwater extraction rates were monitored throughout the test, as were all other relevant data for the skimmer pump test. Test data sheets are provided in Appendix D.

3.5.3 Bioslurper Pump Test

3.5.3.1 Bioslurper Pump Test at Monitoring Well MW-2

Upon completion of the skimmer pump test, preparations were made to begin the bioslurper pump test. Prior to test initiation, depths to LNAPL and groundwater were measured. The slurper tube was then set at the LNAPL/groundwater interface, as in the skimmer pump test. However, in contrast to the skimmer pump test, the PVC connecting tee was plugged, sealing the wellhead and allowing the pump to establish a vacuum in the well (Figure 4). A pressure gauge was installed at the wellhead to measure the vacuum inside the extraction well. The liquid ring pump and oil/water separator were primed with known amounts of groundwater to ensure that any LNAPL or groundwater entering the system could be quantified. The flow totalizers for the LNAPL and aqueous effluent were zeroed, and the liquid ring pump was started on June 15, 1996, to begin the bioslurper pump test. The test was initiated approximately 7.5 hours after the skimmer pump test and was operated continuously for approximately 92 hours. The LNAPL and groundwater extraction rates were monitored throughout the test, as were all other relevant data for the bioslurper pump test. Test data sheets are provided in Appendix D.

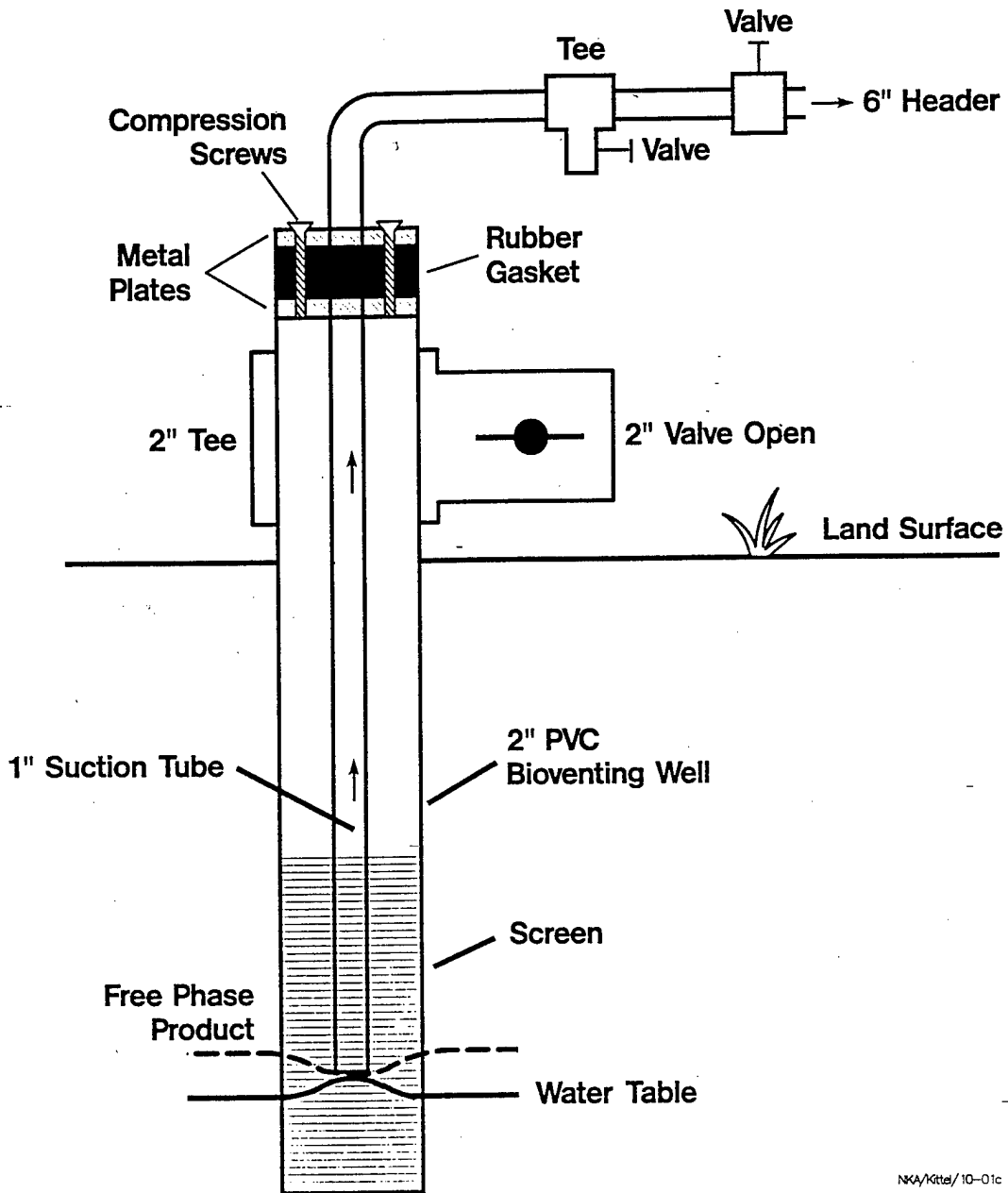

Figure 3. Slurper Tube Placement and Valve Position for the Skimmer Pump Test

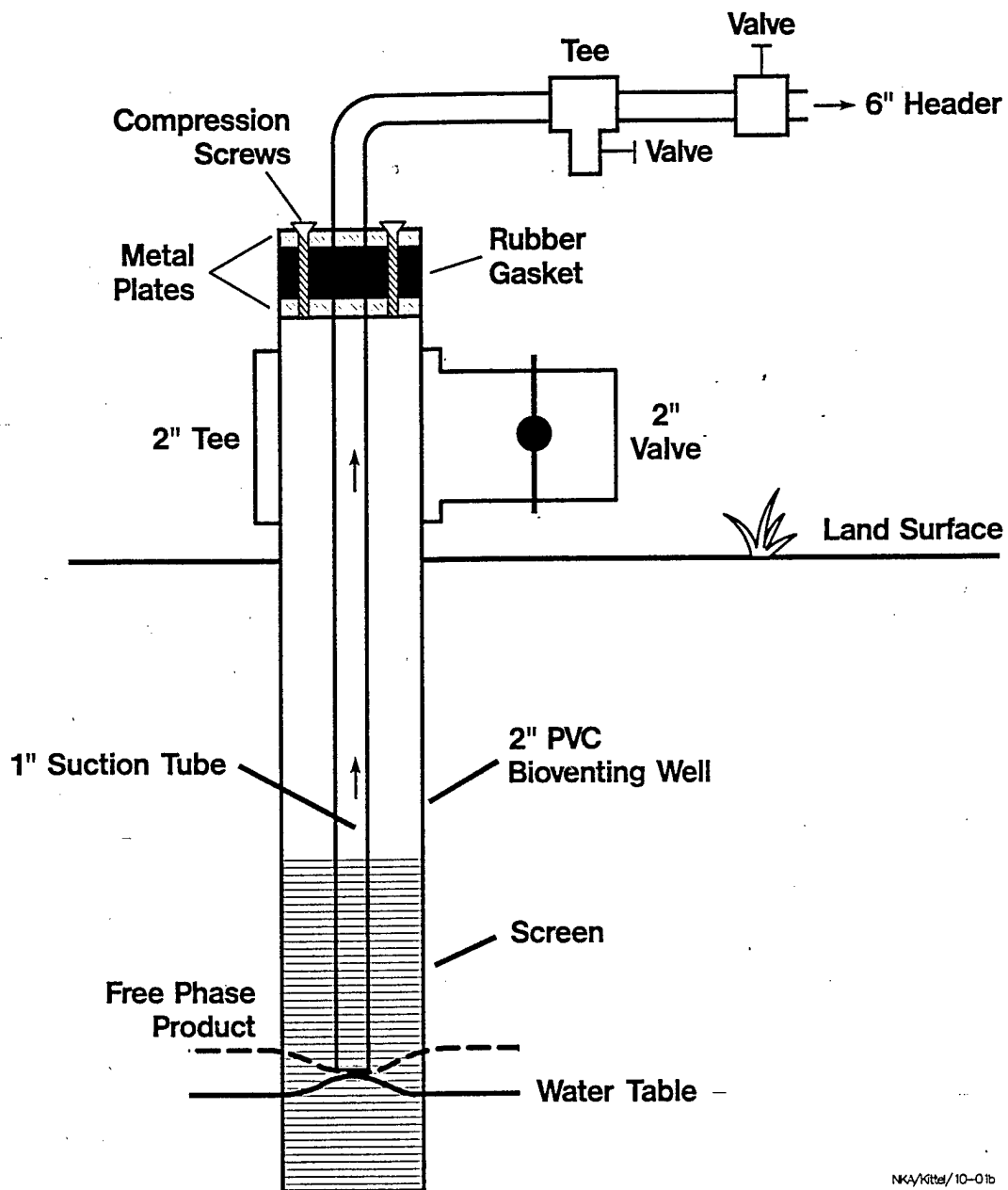

Figure 4. Slurper Tube Placement and Valve Position for the Bioslurper Pump Test

3.5.3.2 Bioslurper Pump Test at Monitoring Wells MW-1, MW-3, and MW-6

Upon completion of the bioslurper pump test at monitoring well MW-2, preparations were made to begin a bioslurper pump test at monitoring wells MW-1, MW-3, and MW-6. Prior to test initiation, depths to LNAPL and groundwater were measured. The monitoring wells were connected with a PVC manifold. The valve and slurper tube configuration were identical to that used for the bioslurper pump test at monitoring well MW-2. The liquid ring pump and oil/water separator were primed with known amounts of groundwater to ensure that any LNAPL or groundwater entering the system could be quantified. The flow totalizers for the LNAPL and aqueous effluent were zeroed, and the liquid ring pump was started on June 19, 1996, to begin the test. The test was initiated approximately 1.5 hours after the bioslurper pump test at MW-2 and was operated continuously for 13 hours. The LNAPL and groundwater extraction rates were monitored throughout the test, as were all other relevant data for the bioslurper pump test. Test data sheets are provided in Appendix D.

3.5.5 Drawdown Pump Test

Upon completion of the bioslurper pump test at monitoring wells MW-1, MW-3, and MW-6, preparations were made to begin the drawdown pump test at MW-2. Prior to test initiation, depths to LNAPL and groundwater were measured. The slurper tube was then set so that the tip was 24 inches below the oil/water interface with the PVC connecting tee open to the atmosphere (Figure 5). The liquid ring pump and oil/water separator were primed with known amounts of groundwater to ensure that any LNAPL or groundwater entering the system could be quantified. The flow totalizers for the LNAPL and aqueous effluent were zeroed, and the liquid ring pump was started on June 20, 1996, to begin the drawdown pump test. The test was initiated approximately 24 hours after the initial bioslurper pump test on MW-2 and was operated continuously for 46 hours. The LNAPL and groundwater extraction rates were monitored throughout the test, as were all other relevant data for the drawdown pump test. Test data sheets are provided in Appendix D.

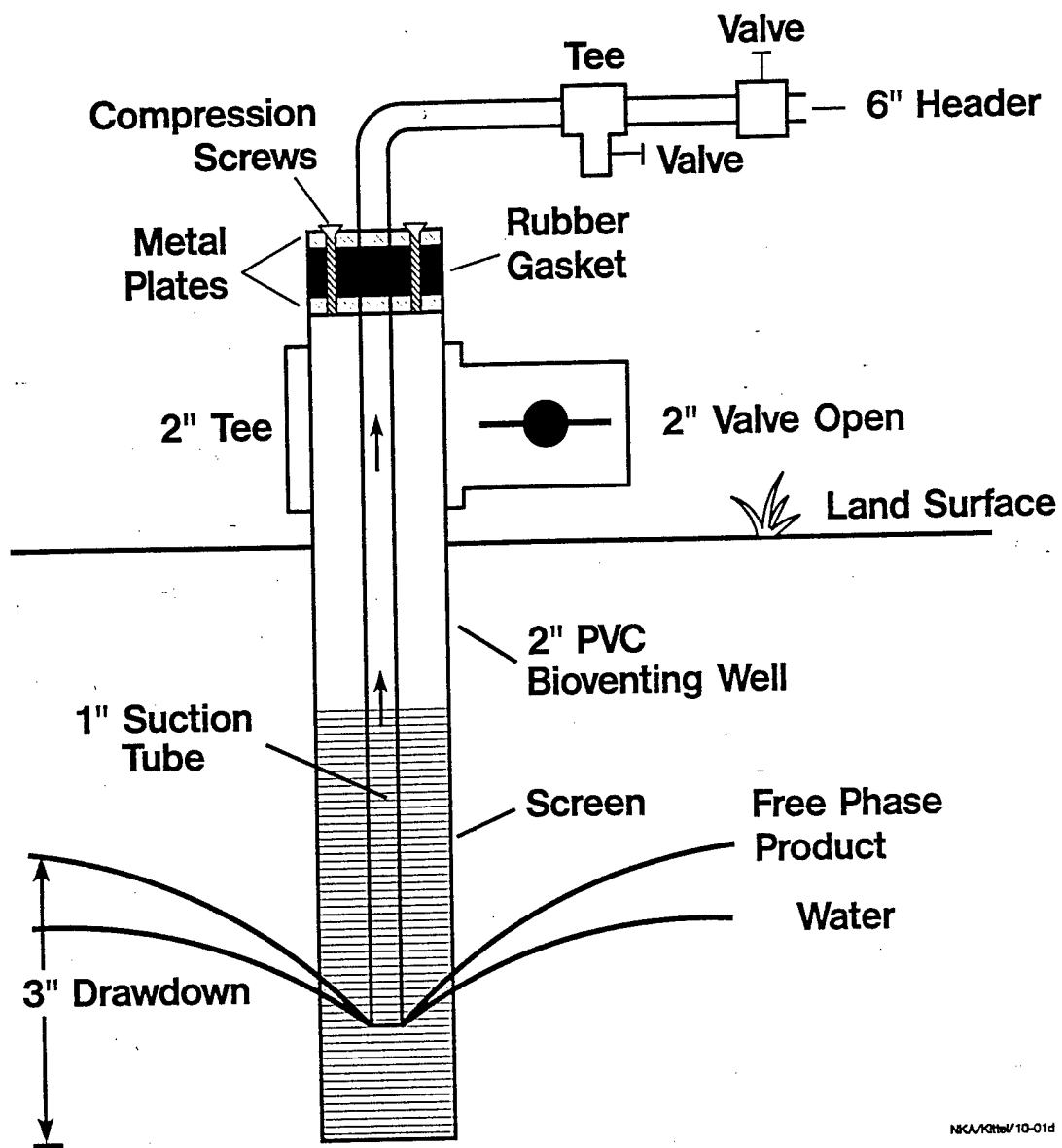

Figure 5. Slurper Tube Placement and Valve Position for the Drawdown Pump Test

3.5.6 Off-Gas Sampling and Analysis

Soil gas samples were collected from the bioslurper off-gas during the bioslurper pump test at MW-2. Samples were collected in Summa™ canisters approximately 47 and 91 hours after test initiation and were labeled SJ-Stack Gas-1 and SJ-Stack Gas-2, respectively. The samples were sent under chain of custody to Air Toxics, Ltd., in Rancho Cordova, California, for analyses of BTEX and TPH.

3.5.7 Groundwater Sampling and Analysis

One groundwater sample was collected during the bioslurper pump test at MW-2. The sample was collected from the bottom of the 1,500 gallon polyethylene storage tank and was labeled SJ-OWS-1. The sample was collected in a 40-mL septa vials containing HCl preservative. The sample was checked to ensure no headspace was present and was then shipped on ice and sent under chain of custody to Alpha Analytical, Inc., in Sparks, Nevada for analyses of BTEX and TPH.

3.6 Soil Gas Permeability Testing

The soil gas permeability test data were collected during the bioslurper pump test at MW-2. Before a vacuum was established in the extraction well, the initial soil gas pressures at the five installed monitoring points were recorded. The start of the bioslurper pump test created a steep pressure drop in the extraction well which was the starting point for the soil gas permeability testing. Soil gas pressures were measured at each of the five monitoring points at all depths to track the rate of outward propagation of the pressure drop in the extraction well. Soil gas pressure data were collected frequently during the first 20 minutes of the test. Pressures were used to determine the radius of influence in the vadose zone. Test data are provided in Appendix E.

3.7 In Situ Respiration Testing

Air containing approximately 2% helium was injected into five monitoring points for approximately 24 hours beginning on June 20, 1996. The setup for the in situ respiration test is described in the *Test Plan and Technical Protocol a Field Treatability Test for Bioventing* (Hinchee et

al., 1992). A 1/3-hp diaphragm pump was used for air and helium injection. Air and helium were injected through the following monitoring points at the depths indicated: MPA-5.0', MPB-4.0', MPC-4.0', MPD-5.0', and MPE-6.0'. After the air/helium injection was terminated, soil gas concentrations of oxygen, carbon dioxide, TPH, and helium were monitored periodically. The respiration test was terminated on June 24, 1996. Oxygen utilization and biodegradation rates were calculated as described in Hinchee et al. (1992). Raw data for these tests are presented in Appendix F.

Helium concentrations were measured during the in situ respiration test to quantify helium leakage to or from the surface around the monitoring points. Helium loss over time is attributable to either diffusion through the soil or leakage. A rapid drop in helium concentration usually indicates leakage. A gradual loss of helium along with a first-order curve generally indicates diffusion. As a rough estimate, the diffusion of gas molecules is inversely proportional to the square root of the molecular weight of the gas. Based on molecular weights of 4 for helium and 32 for oxygen, helium diffuses approximately 2.8 times faster than oxygen, or the diffusion of oxygen is 0.35 times the rate of helium diffusion. As a general rule, we have found that if helium concentrations at test completion are at least 50 to 60% of the initial levels, measured oxygen uptake rates are representative. Greater helium loss indicates a problem, and oxygen utilization rates are not considered representative.

4.0 RESULTS AT SITE SS-12

This section documents the results of the site characterization, the comparative LNAPL recovery pump test, and other supporting tests conducted at Seymour Johnson AFB.

4.1 Baildown Test Results

Total volumes of 27, 15, and 750 mL were removed by hand bailing from monitoring wells MW-1, MW-2, and MW-3, respectively. Results from the baildown tests on MW-1, MW-2, and MW-3 are presented in Table 2. These results indicated that monitoring well MW-2 was the most suitable for the three wells for bioslurper field testing.

Table 2. Results of Baildown Testing in Monitoring Wells MW-1, MW-2, and MW-3

Monitoring Well	Sample Collection Time	Depth to Groundwater (ft)	Depth to LNAPL (ft)	LNAPL Thickness (ft)
MW-1	Initial Reading 6/11/96 16:25	6.97	5.36	1.61
	6/11/96 16:40:30	6.13	5.72	0.41
	6/11/96 16:41:00	6.13	5.71	0.42
	6/11/96 16:42:00	6.13	5.70	0.43
	6/11/96 16:42:30	6.13	5.68	0.45
	6/11/96 16:44:00	6.11	5.66	0.45
	6/11/96 16:46:30	6.13	5.65	0.48
	6/11/96 16:48:30	6.13	5.65	0.48
	6/11/96 16:50:30	6.13	5.65	0.48
	6/11/96 16:55:30	6.14	5.65	0.49
	6/11/96 17:00:00	6.14	5.65	0.49
	6/11/96 17:10:00	6.15	5.65	0.50
	6/11/96 17:25:00	6.16	5.65	0.51
	6/11/96 18:04:00	6.18	5.65	0.53
	6/11/96 18:57:00	6.19	5.65	0.54
	6/11/96 19:05:00	6.20	5.65	0.55
	6/11/96 19:40:00	6.20	5.65	0.55
	6/11/96 21:24:00	6.22	5.67	0.55
	6/11/96 22:44:00	6.24	5.68	0.56
	6/12/96 7:40:00	6.25	5.68	0.57
MW-2	Initial Reading 6/11/96 17:32	7.31	4.95	2.36
	6/11/96 17:48	6.04	5.60	0.44
	6/11/96 17:49	6.03	5.56	0.47
	6/11/96 17:49	6.00	5.53	0.47
	6/11/96 17:50	6.00	5.51	0.49
	6/11/96 17:50	5.98	5.49	0.49
	6/11/96 17:51	5.97	5.48	0.49
	6/11/96 17:51	5.97	5.48	0.49
	6/11/96 17:52	5.96	5.46	0.50
	6/11/96 17:52	5.94	5.45	0.49

Table 2. Results of Baildown Testing in Monitoring Wells MW-1, MW-2, and MW-3 (continued)

Monitoring Well	Sample Collection Time	Depth to Groundwater (ft)	Depth to LNAPL (ft)	LNAPL Thickness (ft)
MW-2	6/11/96 17:52	5.94	5.45	0.49
	6/11/96 17:53	5.95	5.45	0.50
	6/11/96 17:54	5.95	5.44	0.51
	6/11/96 17:55	5.95	5.43	0.52
	6/11/96 17:56	5.95	5.43	0.52
	6/11/96 17:58	5.95	5.42	0.53
	6/11/96 18:00	5.95	5.42	0.53
	6/11/96 18:02	5.95	5.42	0.53
	6/11/96 18:07	5.95	5.40	0.55
	6/11/96 18:12	5.95	5.40	0.55
	6/11/96 18:22	5.96	5.40	0.56
	6/11/96 18:35	6.01	5.40	0.61
	6/11/96 19:00	6.04	5.39	0.65
	6/11/96 19:35	6.07	5.37	0.70
	6/11/96 21:22	6.14	5.38	0.76
	6/11/96 22:42	6.19	5.38	0.81
	6/12/96 7:38	6.21	5.34	0.87
	6/13/96 7:15	6.24	5.29	0.95
	MW-3	Initial Reading 6/11/96 18:51	6.38	5.87
6/11/96 19:12		6.35	6.07	0.28
6/11/96 19:12		6.36	6.07	0.29
6/11/96 19:13		6.36	6.06	0.30
6/11/96 19:13		6.36	6.04	0.32
6/11/96 19:14		6.37	6.06	0.31
6/11/96 19:16		6.37	6.05	0.32
6/11/96 19:18		6.38	6.04	0.34
6/11/96 19:20		6.38	6.04	0.34
6/11/96 19:25		6.39	6.04	0.35
6/11/96 19:30		6.39	6.04	0.35
6/11/96 19:40		6.40	6.03	0.37
6/11/96 21:20		6.43	6.03	0.40
6/11/96 22:38		6.43	6.03	0.40
6/12/96 7:34		6.42	6.01	0.41

4.2 Soil Sample Analyses

Table 3 shows the BTEX and TPH concentrations measured in soil samples collected at Site SS-12. Concentrations at MPD-5.5' were relatively high, with a TPH concentration of 6,800 mg/kg and a total BTEX concentration of 212 mg/kg. The TPH concentration at MPA-5.0 was below the detection limit, while total BTEX at MPA-5.0 was 0.38 mg/kg. The results of the physical characterization of the soils are presented in Table 4.

4.3 LNAPL Pump Test Results

4.3.1 Initial Skimmer Pump Test Results

The LNAPL thickness prior to the initial skimmer pump test was 0.95 ft (Table 5). A total of 0.5 gallons of LNAPL was recovered during this test, with an average recovery rate of 0.26 gallons/day (Table 6). A total of 1,384 gallons of groundwater was extracted with an average extraction rate of 702 gallons/day (Table 6). Results of LNAPL recovery versus time are shown in Figure 6.

4.3.2 Bioslurper Pump Test Results

4.3.2.1 Bioslurper Pump Test Results at MW-2

LNAPL recovery rates increased slightly during the bioslurper pump test (Figure 6). The increase in recovery rate indicates that LNAPL was mobilized to the extraction well under vacuum-enhanced conditions. A total of 1.7 gallons of LNAPL and 6,586 gallons of groundwater was extracted during the bioslurper pump test, with daily average recovery rates of 0.44 gallons/day for LNAPL and 1,700 gallons/day for groundwater (Table 6). The LNAPL recovery rate versus time is shown in Figure 7. The vacuum-exerted wellhead pressure on monitoring well MW-2 was kept relatively constant throughout the bioslurper pump test at approximately 1.8 inches of mercury.

Soil gas concentrations were measured at monitoring points during the bioslurper pump test to determine whether the vadose zone was being oxygenated. Initial oxygen concentrations at MPA-5.0, MPB-4.0, and MPC-4.0 ranged from 13 to 17%, and would not be considered limiting to microbial

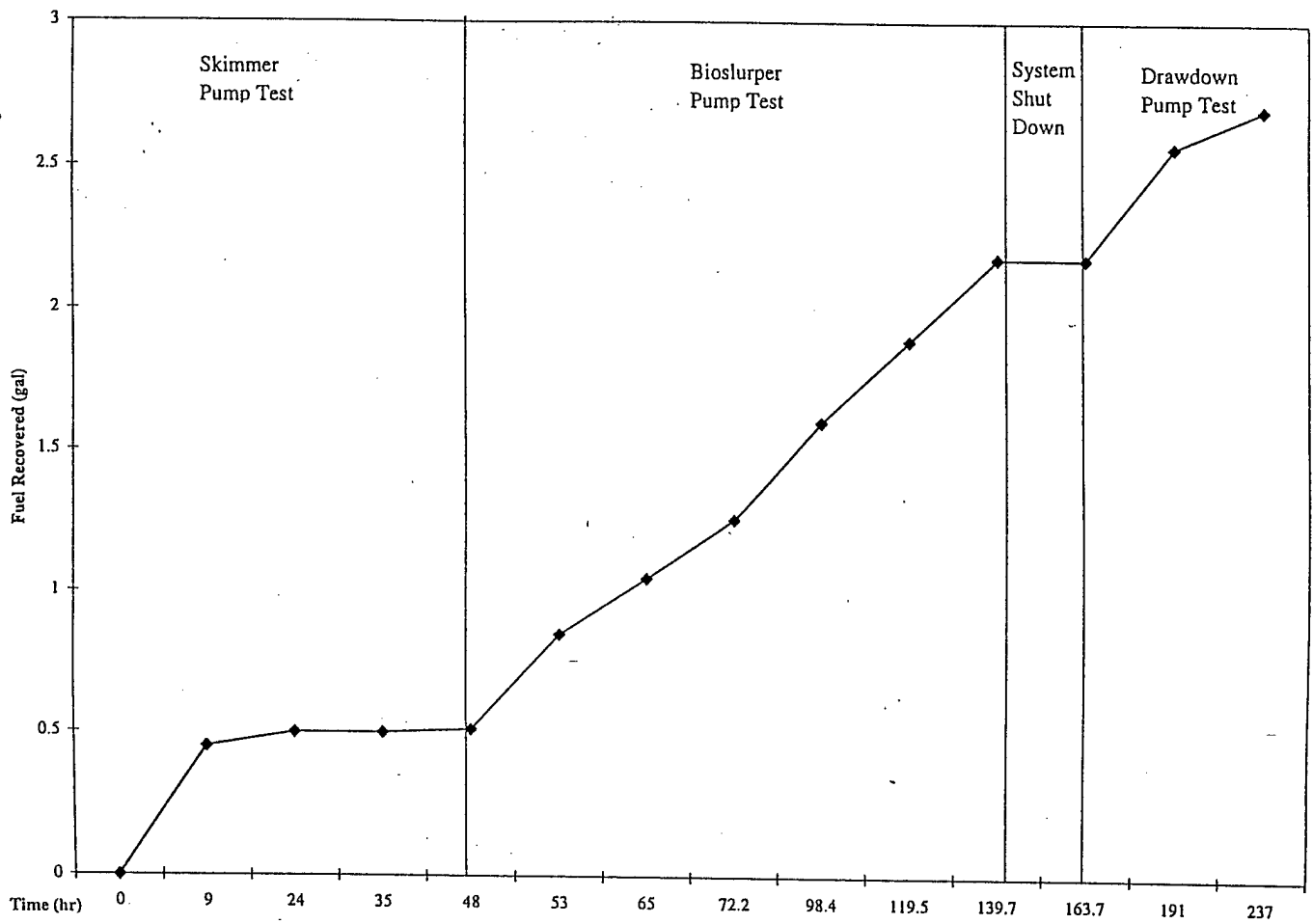
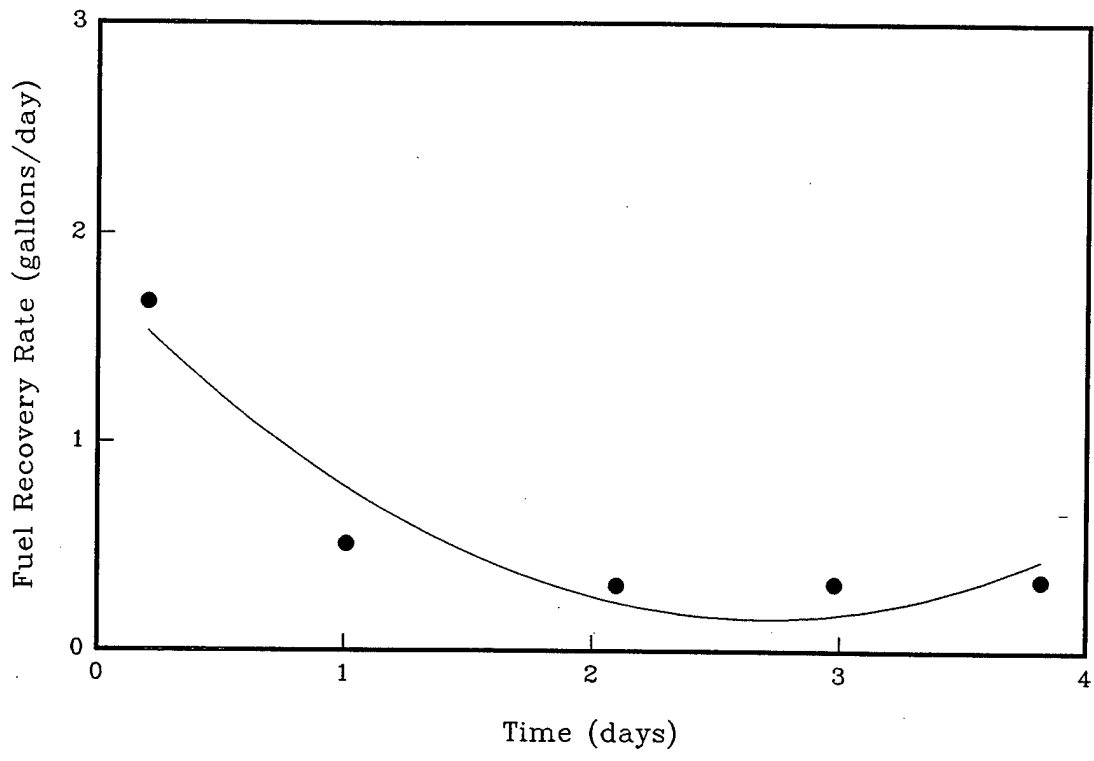

Figure 6. LNAPL Recovery Versus Time During Each Pump Test



c:\plot50\bioslurp\seymour\rate1.sp5

Figure 7. LNAPL Recovery Rate Versus Time During the Bioslurper Pump Test

Table 3. BTEX and TPH Concentrations in Soil Samples from Site SS-12, Seymour Johnson AFB, NC

Parameter	Concentration (mg/kg)	
	SJ-S-MPA-5.0	SJ-S-MPD-5.5
TPH ¹	< 10	6,800
Benzene	0.11	24
Toluene	0.15	80
Ethylbenzene	< 0.020	15
Xylenes	0.12	93

¹ Components are primarily in the range of jet fuel, kerosene, and diesel #1. Lab report, quantitated as gasoline.

Table 4. Physical Characterization of Soil from Site SS-12, Seymour Johnson AFB, NC

Parameter	Sample	
	SJ-S-MPA-5.0'	SJ-S-MPD-5.5'
Moisture Content (%)	15.28	14.67
Porosity (%)	56.2	53.2
Specific Gravity (g/cm ³)	1.16	1.24
Particle Size	Gravel (%)	0
	Sand (%)	91.1
	Silt (%)	2.4
	Clay (%)	6.5

Table 5. Depths to Groundwater and LNAPL Prior to Each Pump Test at MW-2

Test	Test Start Date	Depth to LNAPL (ft)	Depth to Groundwater (ft)	LNAPL Thickness (ft)
Skimmer Pump Test	6/13/96	5.29	6.24	0.95
Bioslurper Pump Test	6/15/96	NM	5.78	0.0
Drawdown Test	6/20/96	5.77	5.90	0.13

NM = Not measured.

Table 6. Pump Test Results at Site SS-12, Seymour Johnson AFB, NC

Recovery Rate (gal/day)	Initial Skimmer Pump Test		Bioslurper Pump Test		Drawdown Pump Test	
	LNAPL	Groundwater	LNAPL	Groundwater	LNAPL	Groundwater
Day 1	0.5	618	0.75	1,267	0.0	1,474
Day 2	0.01	766	0.34	2,294	0.53	1,085
Day 3	NA	NA	0.29	1,527	NA	NA
Day 4	NA	NA	0.29	1,498	NA	NA
Average	0.26	702	0.44	1,724	0.27	1,331
Total Recovery (gal)	0.51	1,384	1.7	6,586	0.53	2,559

NA = Not applicable.

biodegradation processes (Table 7). As the bioslurper pump test progressed, oxygen concentrations decreased while carbon dioxide and TPH concentrations increased, possibly indicating the movement of oxygen-limited soil gas towards the bioslurping well. Over time, it is likely that the area would become well oxygenated.

4.3.2.2 Bioslurper Pump Test Results at MW-1, MW-3, and MW-6

Totals of 3.4 gallons of LNAPL and 2,300 gallons of groundwater were recovered during the bioslurper pump test, with daily average recovery rates of 3.7 gallons/day for LNAPL and 2,500 gallons/day for groundwater. A significant portion of the LNAPL quantified was recovered in the first few minutes of the bioslurper pump test. As the test progressed, fuel recovery dropped substantially.

4.3.3 Drawdown Pump Test

Totals of 0.51 gallon of LNAPL and 2,559 gallons of groundwater were recovered during the drawdown pump test, with daily average recovery rates of 0.27 gallon/day for LNAPL and 1,300 gallons/day for groundwater (Table 6). These results demonstrate that operation of the bioslurper system in the drawdown mode was not as effective a means of free-product recovery as the bioslurper system at this site.

4.4 Extracted Groundwater and Off-Gas Analyses

During the initial bioslurper pump test, a groundwater sample was collected from the bottom of the 1,500 gallon polyethylene tank used for storage prior to disposal. BTEX concentrations were 0.58 mg/L, while the TPH concentration was 2.1 mg/L (Table 8).

Off-gas samples from the bioslurper system also were collected during the bioslurper pump test. The results from the off-gas analyses are presented in Table 9. Given a vapor discharge rate of 25 scfm and using an average concentration of 310 mg/L TPH, approximately 696 lb/day of TPH was emitted to the air during the bioslurper pump test. Benzene emissions were approximately 0.52 lb/day.

Table 7. Oxygen Concentrations During the Bioslurper Pump Test at Site SS-12, Seymour Johnson AFB, NC

Monitoring Point	Oxygen Concentrations (%) Versus Time (hours)			
	0 ¹	2	52	71
MPA-5.0'	13.0	5	7.5	7
MPB-4.0'	17.0	10	6	6
MPC-4.0'	17.0	10	6	6
MPD-5.0'	NR	21	21	20
MPE-6.0'	NR	6	8.5	6

NR No reading

Table 8. BTEX and TPH Concentrations in Extracted Groundwater During the Bioslurper Pump Test at Site SS-12, Seymour Johnson AFB, NC

Parameter	Concentration (mg/L)
	SJ-OWS-1
TPH ¹	2.1
Benzene	0.16
Toluene	0.26
Ethylbenzene	0.024
Total Xylenes	0.14

¹ Components are in the range of jet fuel, diesel, light oil, and motor oil.

Table 9. BTEX and TPH Concentrations in Off-Gas During the Bioslurper Pump Test at Site SS-12, Seymour Johnson AFB, NC

Parameter	Concentration (ppmv)	
	SJ-Stack Gas-1	SJ-Stack Gas-2
TPH as jet fuel	48,000	72,000
Benzene	72	380
Toluene	250	400
Ethylbenzene	24	38
Xylenes	64	110

The composition of LNAPL is shown in Tables 10 and 11 in terms of BTEX concentrations and distribution of C-range compounds, respectively. The distribution of C-range compounds is shown graphically in Figure 8.

4.5 Bioventing Analyses

4.5.1 Soil Gas Permeability and Radius of Influence

The radius of influence is calculated by plotting the log of the pressure change at a specific monitoring point versus the distance from the extraction well. The radius of influence is then defined as the distance from the extraction well where 0.1 inch of H₂O can be measured. Based on this definition, the radius of influence at this site is approximately 21 ft (Figure 9).

4.5.2 In Situ Respiration Test Results

Results from the in situ respiration test are presented in Table 12. Oxygen depletion was relatively slow, with oxygen utilization rates ranging from 0.012 to 0.078 %O₂/hr. Biodegradation rates ranged from 0.25 to 1.5 mg/kg-day. The helium concentration was significantly lower than initial concentrations injected into the monitoring points indicating that leakage and diffusion may have resulted.

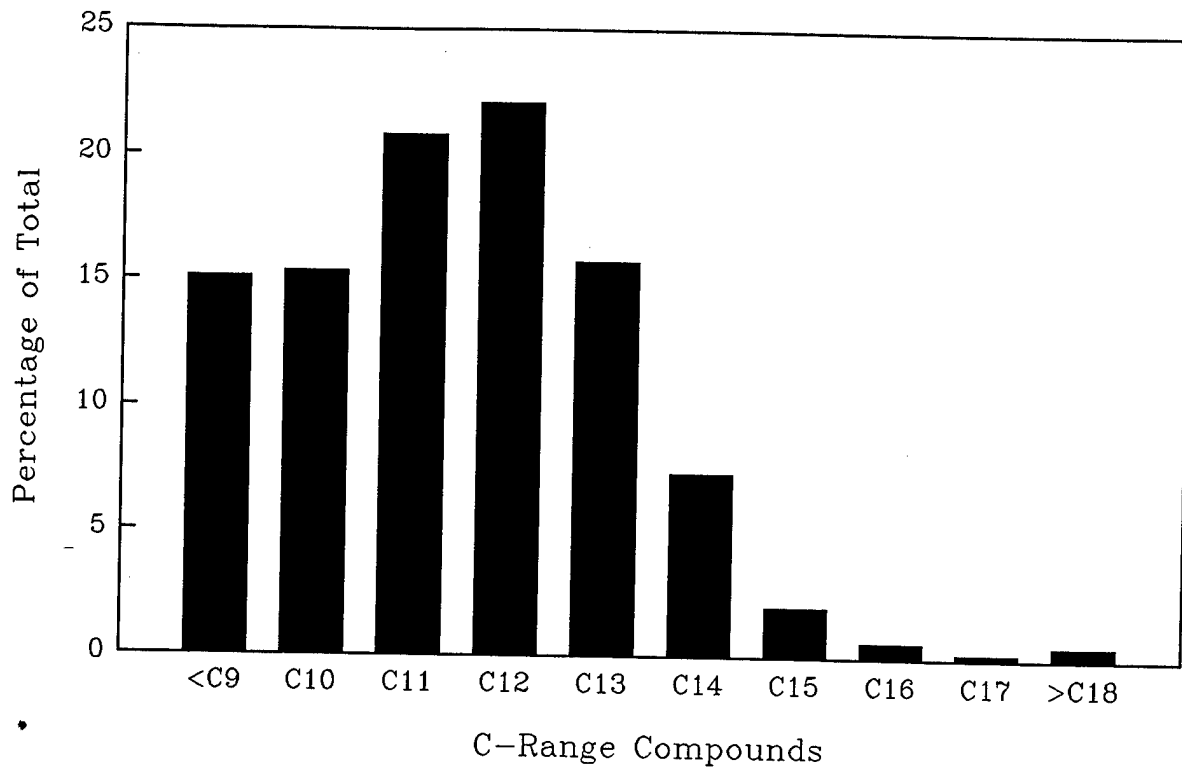

c:\plot50\bioslurp\seymour\orange.sp6

Figure 8. Distribution of C-Range Compounds in Extracted LNAPL at Site 24, Edwards AFB, CA

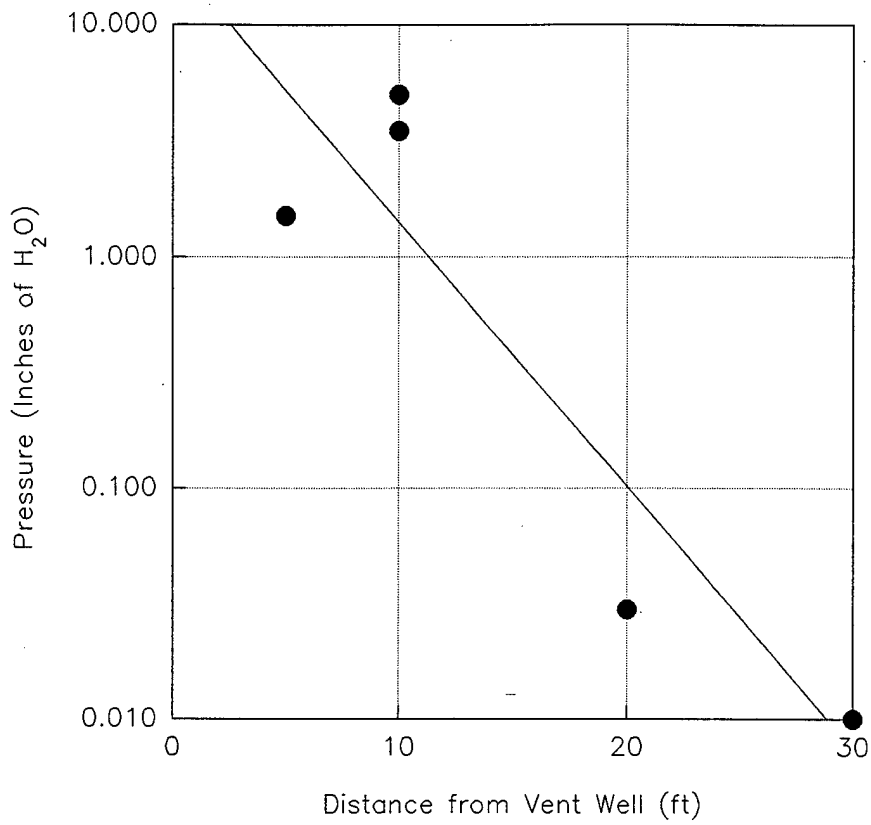

c:\plot50\bioslurp\seymour\radius.ap5

Figure 9. Soil Gas Pressure Change as a Function of Distance During the Soil Gas Permeability Test

Table 10. BTEX Concentrations in LNAPL from Site SS-12, Seymour Johnson AFB, NC

Compound	Concentrations (mg/kg)
Benzene	< 200
Toluene	580
Ethylbenzene	5,700
Total Xylenes	720

Table 11. C-Range Compounds in LNAPL from Site SS-12, Seymour Johnson AFB, NC

C-Range Compounds	Percentage of Total
< C9	15.14
C10	15.37
C11	20.84
C12	22.10
C13	15.78
C14	7.35
C15	2.03
C16	0.64
C17	0.23
> C18	0.53

Table 12. In Situ Respiration Test Results at Seymour Johnson AFB, NC

Monitoring Point	Oxygen Utilization Rate (%/hr)	Biodegradation Rate (mg/kg-day)
MPA-5.0'	0.012	0.25
MPB-4.0'	0.078	1.5
MPC-4.0'	0.019	0.37
MPD-5.0'	0.040	0.80
MPE-6.0'	0.025	0.50

5.0 DISCUSSION OF RESULTS AT SITE SS-12

Overall, fuel recovery for all of the recovery technologies tested was low. Skimmer and drawdown pumping were not as effective as bioslurping at recovering LNAPL at this site; however, differences between the technologies was slight. Free product recovery rates were lower on average during skimmer and drawdown pumping, with average LNAPL recovery rates of 0.26 gallon/day during the skimmer pump test and 0.27 gallon/day during the drawdown pump test. LNAPL recovery rates during bioslurping were approximately 0.44 gallon/day.

Groundwater recovery rates during the bioslurper pump test were high in comparison to rates during the skimmer pump tests, but were comparable to recovery rates during the drawdown pump test. On average, groundwater was extracted at rates of 700 gallons/day during skimming, 1,700 gallons/day during bioslurping, and 1,300 gallons/day during drawdown pumping.

Soil gas concentrations were measured at monitoring points during the bioslurper test to determine whether the vadose zone was being oxygenated. Initial oxygen concentrations at MPA-5.0, MPB-4.0, and MPC-4.0 ranged from 13 to 17%, and would not be considered limiting to microbial biodegradation processes. As the bioslurper test progressed, oxygen concentrations decreased while carbon dioxide and TPH concentrations increased, possibly indicating the movement of oxygen-limited soil gas towards the bioslurping well. Over time, it is likely that the area would become well oxygenated.

Implementation of bioslurping at the Seymour Johnson AFB test site does not appear to be warranted based on the results of the short-term pilot test. Fuel recovery was low in all test configurations (skimming, bioslurper, and drawdown). Bioslurping resulted in a fuel recovery rate of 0.44 gallon/day which is only 0.20 gallon/day more than skimming produced. The pilot test results indicate that LNAPL is not sufficiently mobile to facilitate significant recovery in the existing wells. It appears that recovery efforts beyond the current skimming system would be unlikely to increase fuel recovery results.

6.0 REFERENCES

Battelle. 1995. *Test Plan and Technical Protocol for Bioslurping*, Report prepared by Battelle Columbus Operations for the U.S. Air Force Center for Environmental Excellence, Brooks Air Force Base, Texas.

Hinchee, R.E., S.K. Ong, R.N. Miller, D.C. Downey, and R. Frandt. 1992. *Test Plan and Technical Protocol for a Field Treatability Test for Bioventing* (Rev. 2), Report prepared by Battelle Columbus Operations, U.S. Air Force Center for Environmental Excellence, and Engineering Sciences, Inc. for the U.S. Air Force Center for Environmental Excellence, Brooks Air Force Base, Texas.

APPENDIX A

**SITE-SPECIFIC TEST PLAN FOR BIOSLURPER FIELD ACTIVITIES
AT SEYMOUR JOHNSON AFB, NC**

**SITE-SPECIFIC TEST PLAN FOR BIOSLURPER
TESTING AT SEYMOUR JOHNSON AFB,
NORTH CAROLINA (A002)
CONTRACT NO. F41624-94-C-8012**

FINAL REPORT



PREPARED FOR:

**U.S. AIR FORCE
8001 ARNOLD DRIVE
BUILDING 642
BROOKS AFB, TX 78235**

11 APRIL 1996

FINAL REPORT

**SITE-SPECIFIC TEST PLAN FOR BIOSLURPER TESTING AT
SEYMOUR JOHNSON AIR FORCE BASE, NORTH CAROLINA (A002)
CONTRACT NO. F41624-94-C-8012**

to

**U.S. Air Force
8001 Arnold Drive
Building 642
Brooks AFB, TX 78235**

April 11, 1996

by

**Battelle
505 King Avenue
Columbus, OH 43201**

This report is a work prepared for the United States Government by Battelle. In no event shall either the United States Government or Battelle have any responsibility or liability for any consequences of any use, misuse, inability to use, or reliance upon the information contained herein, nor does either warrant or otherwise represent in any way the accuracy, adequacy, efficacy, or applicability of the contents hereof.

CONTENTS

1.0	INTRODUCTION	1
2.0	SITE DESCRIPTION	2
3.0	PROJECT ACTIVITIES	9
3.1	Mobilization to the Site	9
3.2	Site Characterization Tests	10
3.2.1	Baildown Tests	10
3.2.2	Soil-Gas Survey (Limited)	10
3.2.3	Monitoring Point Installation	11
3.2.4	Soil Sampling	14
3.3	Bioslurper System Installation and Operation	14
3.3.1	System Setup	15
3.3.2	System Shakedown	15
3.3.3	System Startup and Test Operations	17
3.3.4	Soil-Gas Permeability Test	17
3.3.5	In Situ Respiration Test	17
3.3.6	Extended Testing	18
3.4	Demobilization	18
4.0	BIOSLURPER SYSTEM DISCHARGE	19
4.1	Vapor Discharge Disposition	19
4.2	Aqueous Influent/Effluent Disposition	20
4.3	Free-Product Recovery Disposition	20
5.0	SCHEDULE	21
6.0	PROJECT SUPPORT ROLES	22
6.1	Battelle Activities	22
6.2	Seymour Johnson AFB Support Activities	22
6.3	AFCEE Activities	24

FIGURES

Figure 1.	Location of Areas of Interest for Bioslurper Testing at Seymour Johnson AFB	3
Figure 2.	Locations of Existing and Proposed Monitoring Wells at Site SS-12	4
Figure 3.	Extent of Free-Product Plume at Site SS-04	6
Figure 4.	Interpreted Extent of Groundwater Contamination for BTEX and TPH at SS-04 Pump House #1	7
Figure 5.	General Bioslurper Well and Monitoring Point Arrangement	12
Figure 6.	Diagram of a Typical Bioslurper Soil-Gas Monitoring Point	13
Figure 7.	Conceptual Arrangement of Soil-Gas Monitoring Points at SS-04	14
Figure 8.	Bioslurper Process Flow	15
Figure 9.	Diagram of a Typical Bioslurper Well	16
Figure 10.	Route to Seymour Johnson AFB Hospital	25

CONTENTS (Continued)

TABLES

TABLE 1.	SUBSURFACE APPARENT FUEL THICKNESS FOR WELLS AT SITE SS-04	5
TABLE 2.	GROUNDWATER CONTAMINATION CONCENTRATIONS AT SITE SS-04, PUMP HOUSE #1, SEYMOUR-JOHNSON AFB	8
TABLE 3.	SURFACE APPARENT FUEL THICKNESS FOR WELLS AT SITE SS-12	8
TABLE 4.	SCHEDULE OF BIOSLURPER TEST ACTIVITIES	9
TABLE 5.	VOLUMES PER UNIT LENGTH FOR COMMON WELL CASING DIAMETERS	10
TABLE 6.	BENZENE AND TPH DISCHARGE LEVELS AT PREVIOUS BIOSLURPER TEST SITES	19
TABLE 7.	AIR RELEASE SUMMARY INFORMATION	20
TABLE 8.	HEALTH AND SAFETY INFORMATION CHECKLIST	23

SITE-SPECIFIC TEST PLAN FOR BIOSLURPER FIELD ACTIVITIES AT SEYMOUR JOHNSON AIR FORCE BASE, NORTH CAROLINA

U.S. Air Force
Brooks AFB

April 11, 1996

1.0 INTRODUCTION

The Air Force Center for Environmental Excellence is conducting a nationwide application of an innovative technology for free-product recovery and soil bioremediation. The technology tested in the Bioslurper Initiative is vacuum-enhanced free-product recovery/bioremediation (bioslurping). The field test and evaluation are intended to demonstrate the initial feasibility of bioslurping by measuring system performance in the field. System performance parameters, mainly free-product recovery, will be determined at numerous sites. Field testing will be performed at many sites to determine the effects of different organic contaminant types and concentrations and different geological conditions on bioslurping effectiveness.

Plans for the field test activities are presented in two documents. The first is the overall test plan and technical protocol for the entire program, titled *Test Plan and Technical Protocol for Bioslurping* (Battelle, 1995). The overall plan is supplemented by plans specific to each test site. The concise site-specific plans effectively communicate regulatory background to Base personnel.

The overall test plan and protocol was developed as a generic plan for the Bioslurper Initiative to improve the accuracy and efficiency of test plan preparation. The field program requires installation and operation of the bioslurping system supported by a wide variety of site characterization, performance monitoring, and chemical analysis activities. The basic methods to be applied from site to site do not change. Preparation and review of the overall plan allows efficient documentation and review of the basic approach to the test program. Peer and regulatory review were performed for the overall plan to ensure the credibility of the overall program.

This letter report is the site-specific plan for application of bioslurping at Seymour Johnson Air Force Base, North Carolina. It was prepared based on site-specific information received by Battelle from Seymour Johnson AFB and other pertinent site-specific information to support the generic test plan.

Site-specific information for Seymour Johnson AFB included data for the Bulk Fuel Storage Area (Sites ST-01, SD-02, SD-03, and ST-05) and the Strategic Air Command (SAC) Flight line Fuel Hydrant System (Sites SS-04 and SS-12). An initial review of the data indicates that either Site SS-04 or SS-12 are the most likely candidates for the bioslurper pilot test. Significant LNAPL thickness is present in wells at both SS-04 and SS-12. If Sites SS-04 and SS-12 are determined to be unsuitable for testing, the Bulk Fuel Storage Area could be used as a viable alternative for the bioslurper pilot test activities.

2.0 SITE DESCRIPTION

The sites of interest at Seymour Johnson AFB are Sites SS-04 and SS-12, both facilities are part of the SAC Flight line Fuel Hydrant System. Site SS-04 is located at Pump House #1 (Building 4551) on the Fuel Hydrant System and Site SS-12 is located at Pump House #3 (Building 4553).

Figure 1 shows the SS-04 site and the monitoring well locations within the area. Figure 2 shows existing and proposed wells for SS-12. Depth to ground water at both sites is approximately 5 to 7 ft. The well boring records for SS-04 and SS12 monitoring wells (Law Environmental, 1992) are shown in Appendix A and B, respectively.

Table 1 displays product thickness measurements taken from monitoring wells and boreholes for Site SS-04. The greatest levels of contamination occur south-southwest of Building 4551. Figure 3 shows the extent of the free-product plume at Site SS-04. From these data, the well that appears most likely to yield significant amounts of free product is Well #MW-1502S. Monitoring wells 1508s and 1510s also exhibit significant LNAPL thicknesses.

Table 2 (adapted from Law Environmental, 1992) displays the results of groundwater analysis in the area of Pump House 1 (Law Environmental, 1992). Total petroleum hydrocarbon (TPH) concentrations as high as 2,900 ppm were observed at this site. Figure 4 shows the water sample locations and the interpreted extent of the groundwater contamination.

At Site SS-12 monitoring wells 1, 2, 3, and 6 all exhibit significant LNAPL thicknesses. Table 3 presents free-product thicknesses observed in February 1995.

Site characterization (see Section 3.2) will begin with baildown testing at the wells residing in the free-product plume at both sites. Based on results of bail down testing at each site and depending on site logistics, the best site for the bioslurper pilot test will be selected. If preliminary site characterization indicates that the wells at both sites are unsuitable, or if site logistics prevent their use, the Bulk Fuel Storage Area could be used as a substitute bioslurper test site.

SITE 15 - SOIL BORING AND MONITORING WELL LOCATIONS

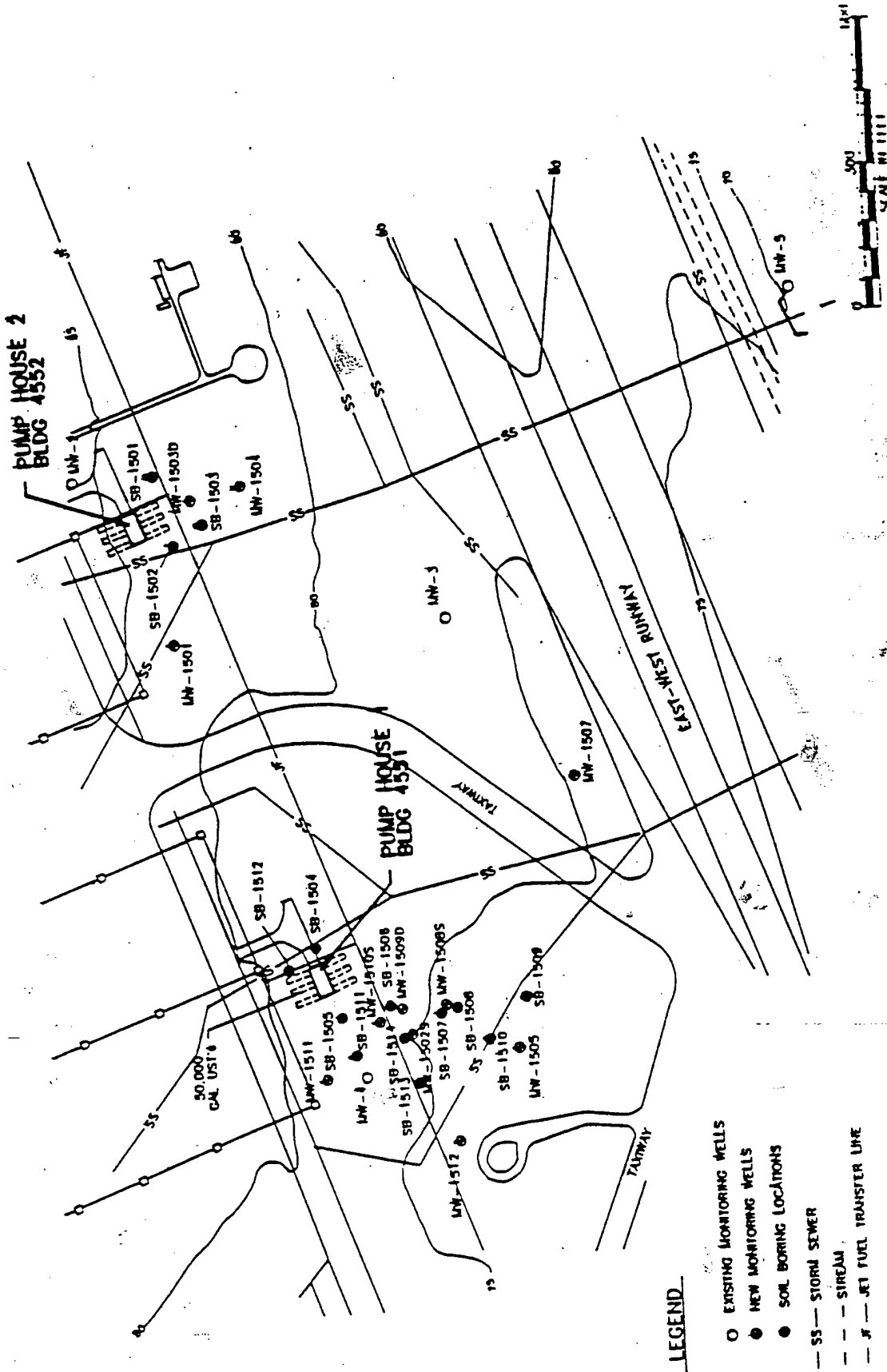
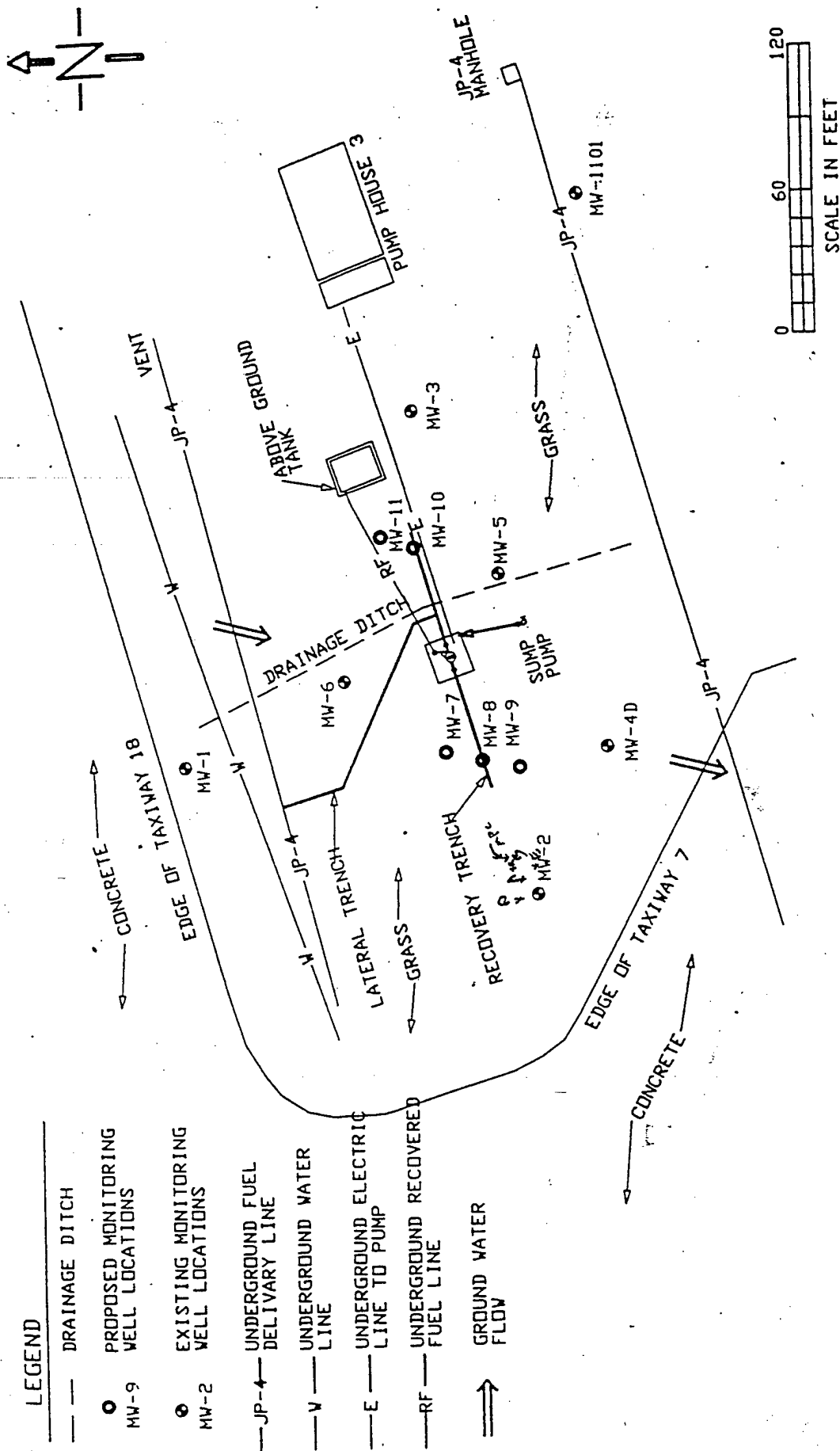

Figure 1. Location of Areas of Interest for Biosurper Testing at Seymour Johnson AFB.



SOURCE: IT, 1993

Figure 2. Locations of Existing and Proposed Monitoring Wells at Site SS-12.

Table 1. Subsurface Apparent Fuel Thickness for Wells at Site SS-04

Well Identification	Date Measured	Product Thickness (feet)
MW-1	3/21/91	0
MW-2	3/21/91	0
MW-3	3/21/91	0
MW-4	3/21/91	0
MW-5	3/21/91	0
MW-6	3/21/91	0
MW-1501	3/21/91	0
MW-1502S	2/2/95	1.51
MW-1503D	3/21/91	0
MW-1504	3/21/91	0
MW-1505	2/2/95	0
MW-1506	3/21/91	0
MW-1507	3/21/91	0
MW-1508S	2/2/95	0.95
MW-1509D	2/2/95	0
MW-1510S	2/2/95	0.91
MW-1511	2/2/95	0
MW-1512	2/2/95	0
SB-1501	2/5/91	0
SB-1502	2/5/91	0
SB-1503	2/5/91	0
SB-1504	2/5/91	0
SB-1505	2/5/91	0
SB-1506	2/5/91	1.49
SB-1507	2/5/91	1.23
SB-1508	2/5/91	1.44
SB-1509	2/5/91	0
SB-1510	2/5/91	0
SB-1511	2/5/91	0
SB-1512	2/5/91	0
SB-1513	2/5/91	1.17
SB-1514	2/5/91	2.10

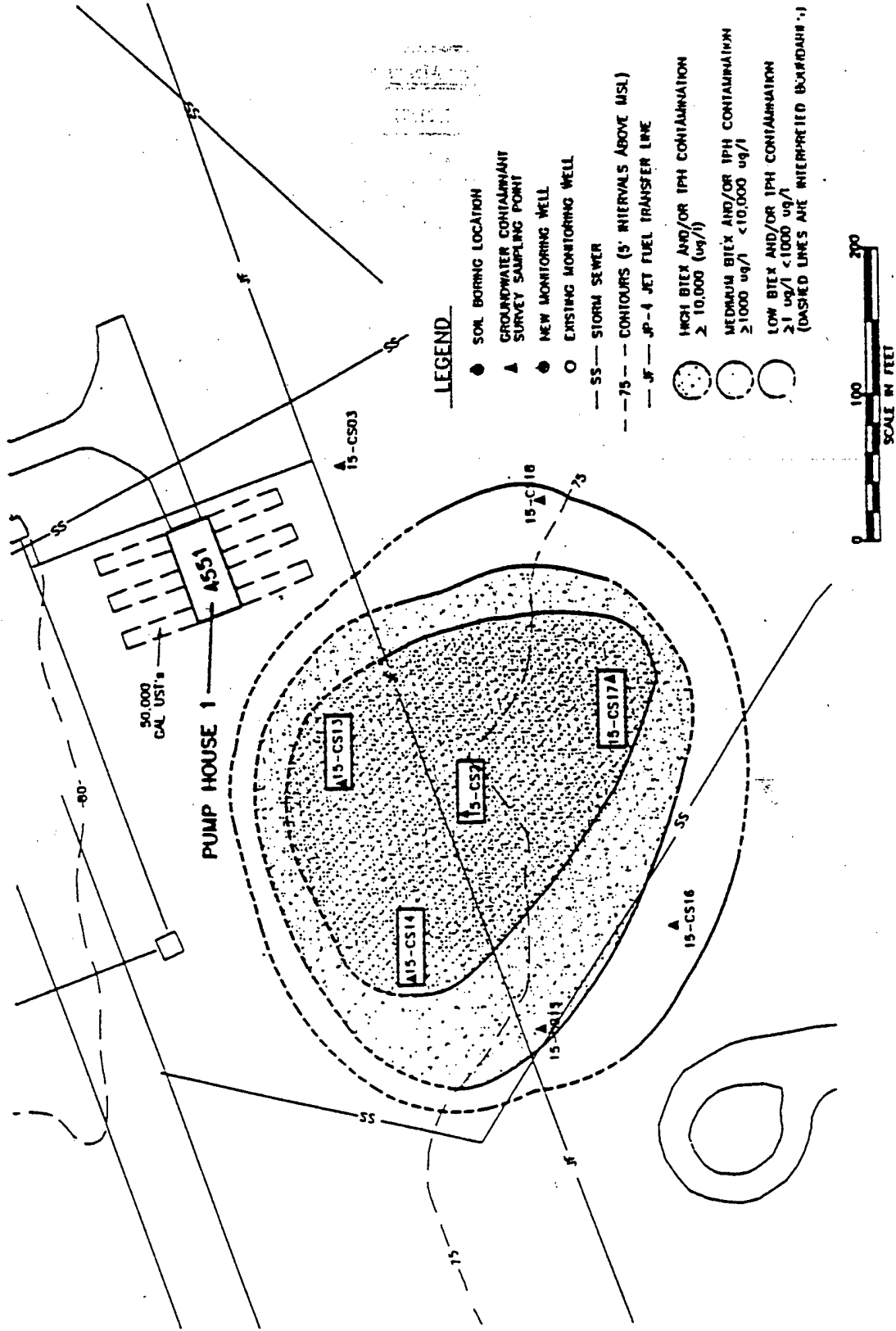

Figure 3. Extent of Free-Product Plume at Site SS-04.

SITE 15-INTERPRETED EXTENT OF NAPL CONTAMINATION

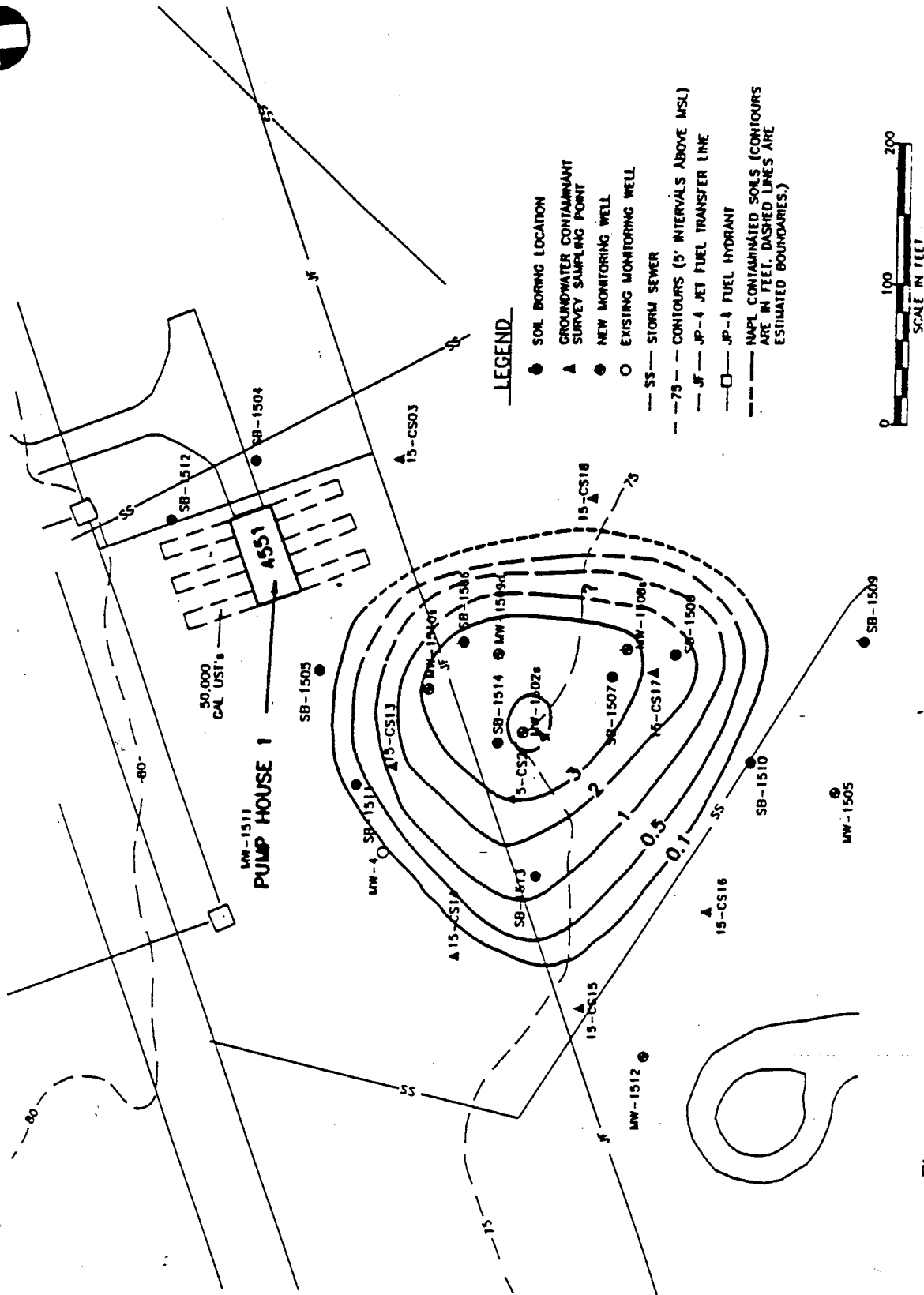

Figure 4. Interpreted Extent of Groundwater Contamination for BTEX and TPH at SS-04 Pump House #1

Table 2. Groundwater Contamination Concentrations at Site SS-04, Pump House #1, Seymour-Johnson AFB

Sample ID	Benzene ($\mu\text{g/L}$)	Toluene ($\mu\text{g/L}$)	Ethylbenzene ($\mu\text{g/L}$)	Xylenes ($\mu\text{g/L}$)	TPH ($\mu\text{g/L}$)
15CS-1	<2	<2	<2	<4	<2
15CS-2	<480	78,000	<440	<700	760,000
15CS-3	<2	<2	<0.2	<2	<2
15CS-4	<1	<1	<1	<1	<1
15CS-13	<1,700	34,400	<1,500	<2,500	2,900,000
15CS-14	3,200	2,400	<15	<25	17,000
15CS-15	1,000	560	<3	70	3,600
15CS-16	<2	<2	<2	<2	37
15CS-17	<1,700	100,000	<1,500	<2,500	2,900,000
15CS-18	<0.3	1	<0.3	<0.5	6

Table 3. Subsurface Apparent Fuel Thickness for Wells at Site SS-12

Well Identification	Date Measured	Product Thickness (feet)
MW-10	12/21/95	0
MW-11	12/21/95	0
MW-8	12/21/95	0
MW-11	1/23/96	0
MW-10	1/23/96	0
MW-7	1/23/96	0.02
MW-8	1/23/96	0
MW-9	1/23/96	0
MW-5	1/23/96	0.63
MW-1	1/23/96	1.66
MW-6	1/23/96	0.92
MW-2	1/23/96	1.92
MW-3	1/23/96	0.98
MW-4D	1/23/96	0

3.0 PROJECT ACTIVITIES

The following field activities are planned for the bioslurper pilot test at Seymour Johnson AFB. Additional details about the activities are presented in the *Test Plan and Technical Protocol for Bioslurping* (Battelle, 1995). As appropriate, specific sections in the generic Bioslurping Protocol assessment are referenced. Table 4 shows the schedule of activities for the Bioslurper Initiative at Seymour Johnson AFB.

Table 4. Schedule of Bioslurper Test Activities

Pilot Test Activity	Schedule
Mobilization	day 1-2
Site Characterization	day 2-3
Baildown Tests and Product/Groundwater Interface Monitoring	
Soil-Gas Survey (limited)	
Monitoring Point (MP) Installation (3 MPs)	
Soil Sampling (TPH, BTEX ^(a) , physical characteristics)	
System Installation	day 2-3
Test Startup	day 3
Skimmer Test (2 days)	day 3-4
Bioslurper Vacuum Extraction (4 days)	day 6-9
Soil-Gas Permeability Testing	day 6
Skimmer Test (continued)	day 10
In Situ Respiration Test — air/helium injection	day 10
In Situ Respiration Test — monitoring	day 11-16
Drawdown Pump Test (2 days)	day 11-12
Demobilization/Mobilization	day 13-14

^(a) BTEX = benzene, toluene, ethylbenzene, and xylenes.

3.1 Mobilization to the Site

After the site-specific test plan is approved, Battelle staff will mobilize equipment. All of the equipment will be driven via cargo van to Seymour Johnson AFB by Battelle staff. The Base Point of Contact (POC) will have been asked in advance to find a suitable holding facility to receive any bioslurper pilot test equipment that could be sent in advance of Battelle staff. The storage facility should allow Battelle staff to easily set up the bioslurper pilot demonstration when they arrive on site.

The exact mobilization date will be confirmed with the Base POC as far in advance of fieldwork as is possible. The Battelle POC will provide the Air Force POC with information on each Battelle employee who will be on site.

3.2 Site Characterization Tests

3.2.1 Baildown Tests

The baildown test is the primary test for selection of the bioslurper test well. Baildown tests will be performed at wells that contain measurable thicknesses of light, nonaqueous-phase liquid (LNAPL) to estimate the LNAPL recovery potential at those particular wells. In most cases, the well exhibiting the highest rate of LNAPL recovery will be selected for the bioslurper extraction well. Table 5 presents the volume of fuel that would be present in a 1-foot measured thickness for various size wells. Detailed procedures for the baildown tests are provided in Section 5.6 of the generic Bioslurping Protocol.

Table 5. Volumes per Unit Length for Common Well Casing Diameters

Nominal Pipe Size	Gal/ft (Schedule 40 Pipe)	Gal/ft (Schedule 80 Pipe)
2.0	0.174	0.153
3.0	0.384	0.343
4.0	0.661	0.597
6.0	1.50	1.35

3.2.2 Soil-Gas Survey (Limited)

A small-scale soil-gas survey will be conducted to identify the best location for installation of the bioslurping system. The soil-gas survey will be conducted in areas where historical site data indicate the highest contamination levels. Table 1 shows the wells with substantial free product. The area around these wells will be surveyed to select the locations for installation of soil-gas monitoring points. Soil-gas surveying will be concentrated around areas that exhibit the following characteristics.

1. Soil vapor from the site will exhibit high total petroleum hydrocarbon (TPH) concentrations (10,000 ppm or greater).
2. Soil vapor will contain relatively low oxygen concentrations (between 0% and 2%).
3. Soil vapor will have relatively high carbon dioxide concentrations (depending on soil type, between 2% and 10% or greater).

To obtain further information about the soil-gas survey, consult Section 5.2 of the generic Bioslurping Protocol.

3.2.3 Monitoring Point Installation

Monitoring points must be installed to determine the radius of influence that the free-product recovery system has on vadose zone contaminated soils. A general arrangement of the bioslurping well and monitoring points is shown in Figure 5.

Upon conclusion of the initial soil-gas survey and baildown tests, at least three soil-gas monitoring points will be installed to measure soil-gas changes that occur during the operation of the bioslurper. These monitoring points should be located in highly contaminated soils within the free-phase plume and should be positioned to allow detailed monitoring of the in situ changes in soil-gas composition caused by the bioslurper system. The components of soil-gas monitoring points are shown in Figure 6. A conceptual arrangement for soil-gas monitoring points at SS-04 is presented in Figure 7. Information on monitoring point installation can be found in Section 4.2.1 of the generic Bioslurping Protocol.

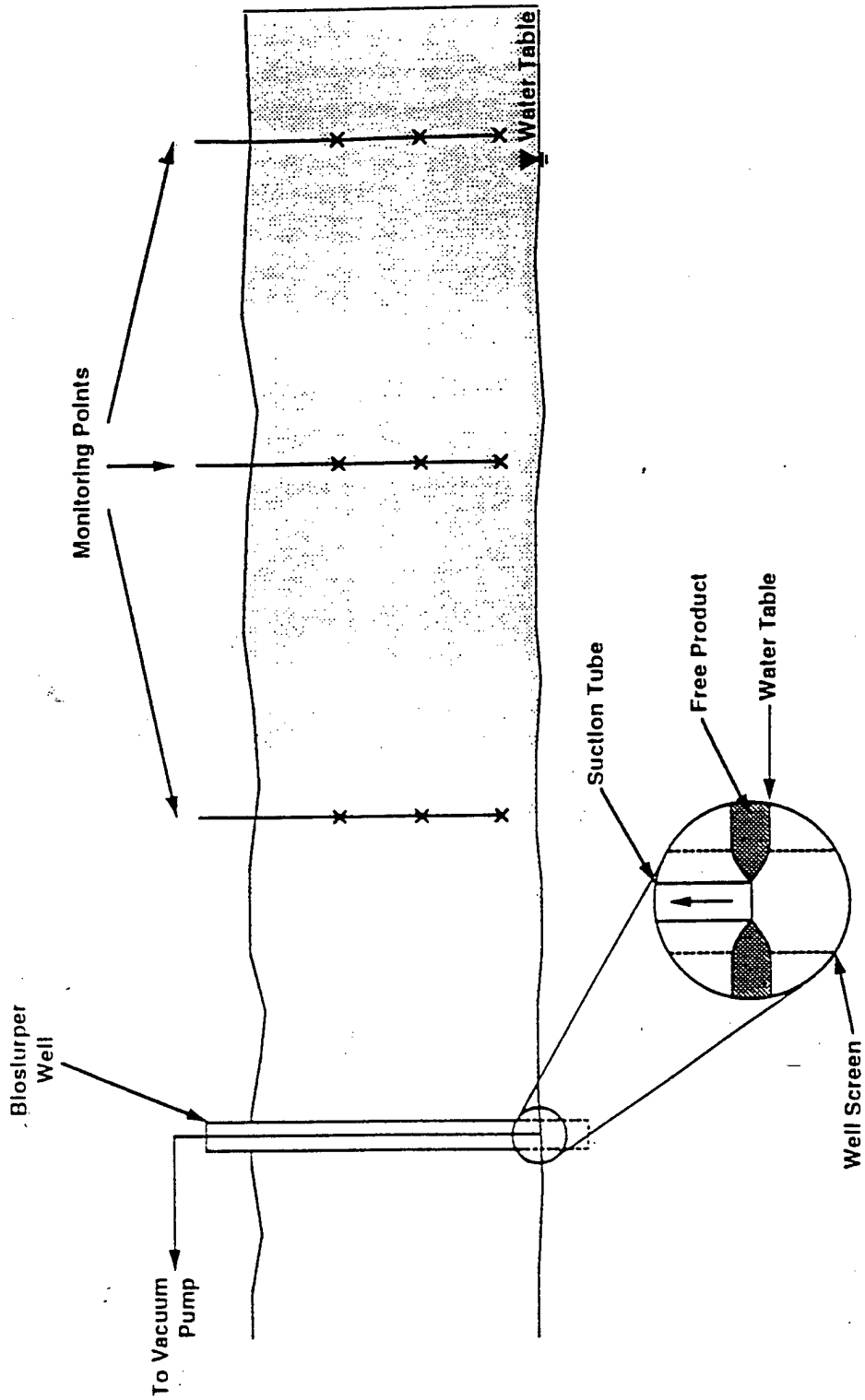

Figure 5. General Bioslurper Well and Monitoring Point Arrangement

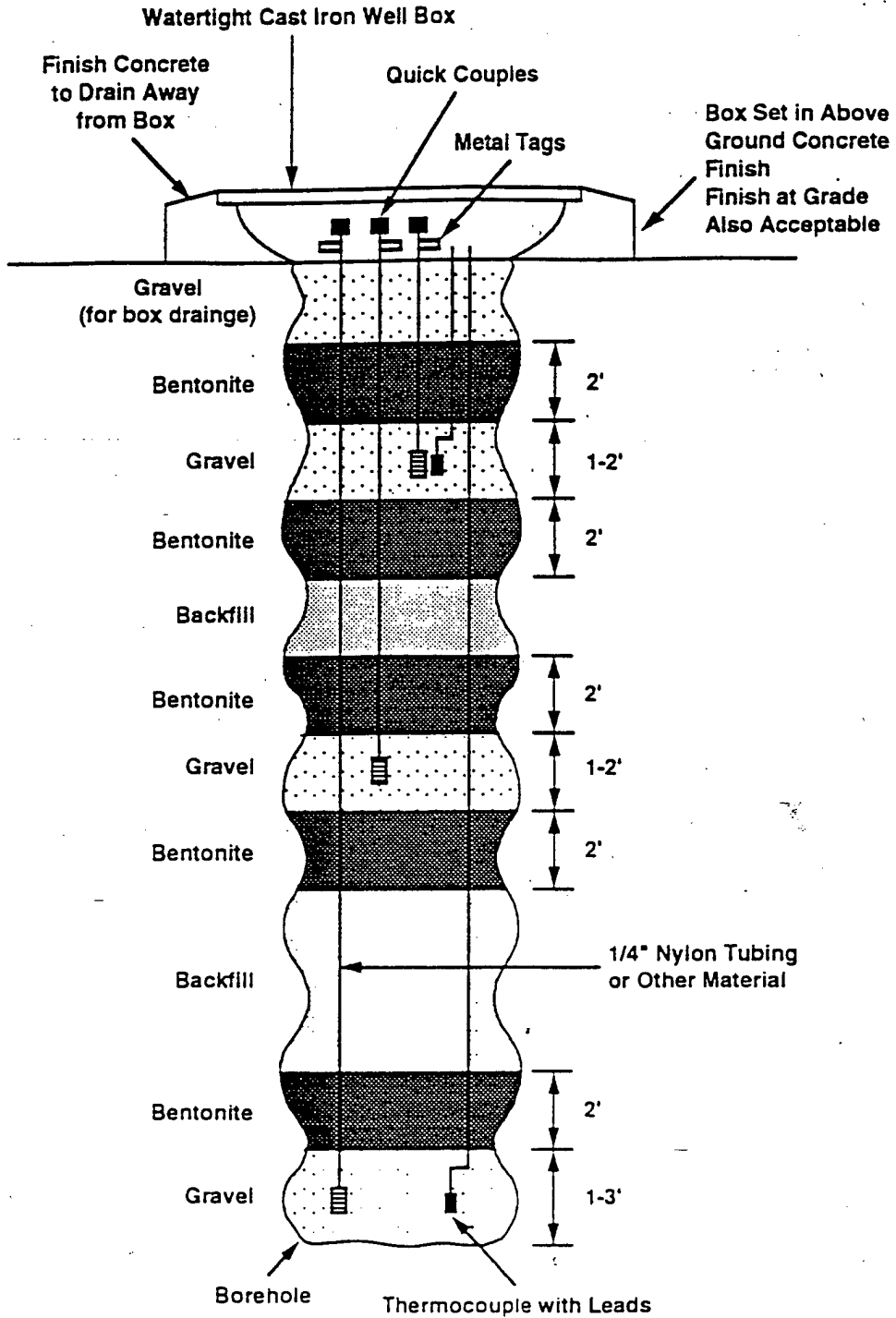
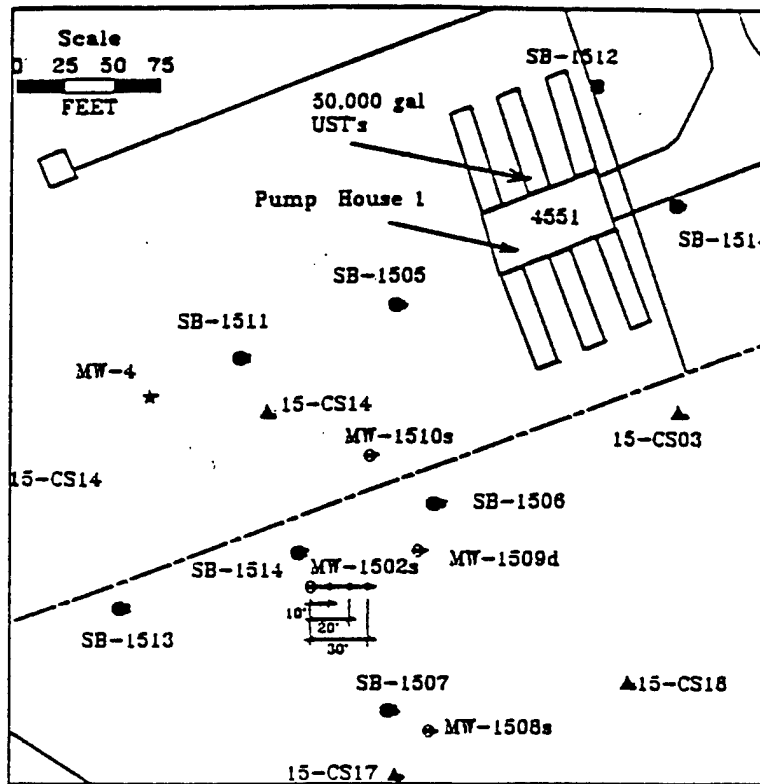

Figure 6. Diagram of a Typical Bioslurper Soil-Gas Monitoring Point



Legend

- Soil Boring
- ▲ GW Contaminant Survey Sampling Point
- ★ Existing Monitoring Well
- ◆ Soil Gas Monitoring Point
- ➔ New Monitoring Well
- Jet Fuel Transfer Line

Figure 7. Conceptual Arrangement for Soil-Gas Monitoring Points at SS-04

3.2.4 Soil Sampling

Soil samples will be collected to determine the physical and chemical composition of the soil near the bioslurper test site. Soil samples will be collected from the boreholes advanced for monitoring point installation at two or three locations at the site chosen for the bioslurper test. Generally, samples will be collected from the capillary fringe over the free product.

Soil samples will be analyzed for particle-size distribution; bulk density; porosity; moisture content; benzene, toluene, ethylbenzene, and xylenes (BTEX); and TPH. Section 5.5.1 of the generic Bioslurping Protocol will be consulted for information on the field measurements and sample collection procedures for soil sampling.

3.3 Bioslurper System Installation and Operation

Once the well to be used for the bioslurper test installation at Seymour Johnson AFB has been identified, the bioslurper pump and support equipment will be installed and the pilot test will be initiated.

3.3.1 System Setup

After the preliminary site characterization has been completed and the bioslurper candidate well has been selected, the equipment will be mobilized from the holding facility to the test site, and the bioslurper system will be assembled. Figure 8 shows a flow diagram of the bioslurper process. Figure 9 is a generic diagram of the bioslurper extraction well that will be installed at Seymour Johnson AFB. Before the LNAPL recovery tests are initiated, all relevant baseline field data will be collected and recorded. These data will include soil-gas concentrations, initial soil-gas pressures, the depth to groundwater, and the LNAPL thickness. Ambient soil and all atmospheric conditions (e.g., temperature, humidity, barometric pressure) also will be recorded. All emergency equipment (i.e., emergency shutoff switches and fire extinguishers) will be installed and checked for proper operation at this time.

A clear, level area near the well selected for the bioslurper test installation will be identified for the 20' x 10' flatbed trailer that holds the equipment required for bioslurper system operation. For more information on bioslurper system installation, consult Section 6.0 of the generic Bioslurping Protocol.

3.3.2 System Shakedown

A brief startup test will be conducted to ensure that the system is constructed properly and operates safely. All system components will be checked for problems and/or malfunctions. A checklist will be provided to document the system shakedown.

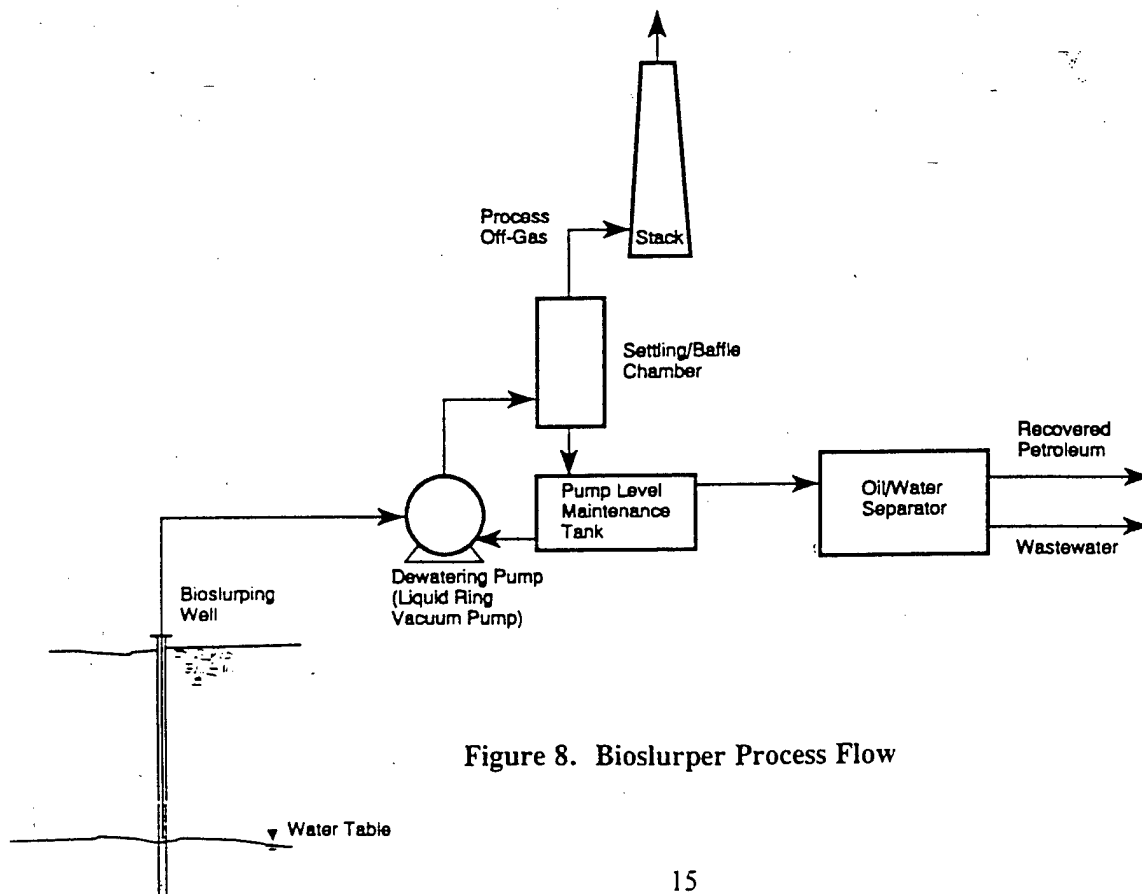

Figure 8. Bioslurper Process Flow

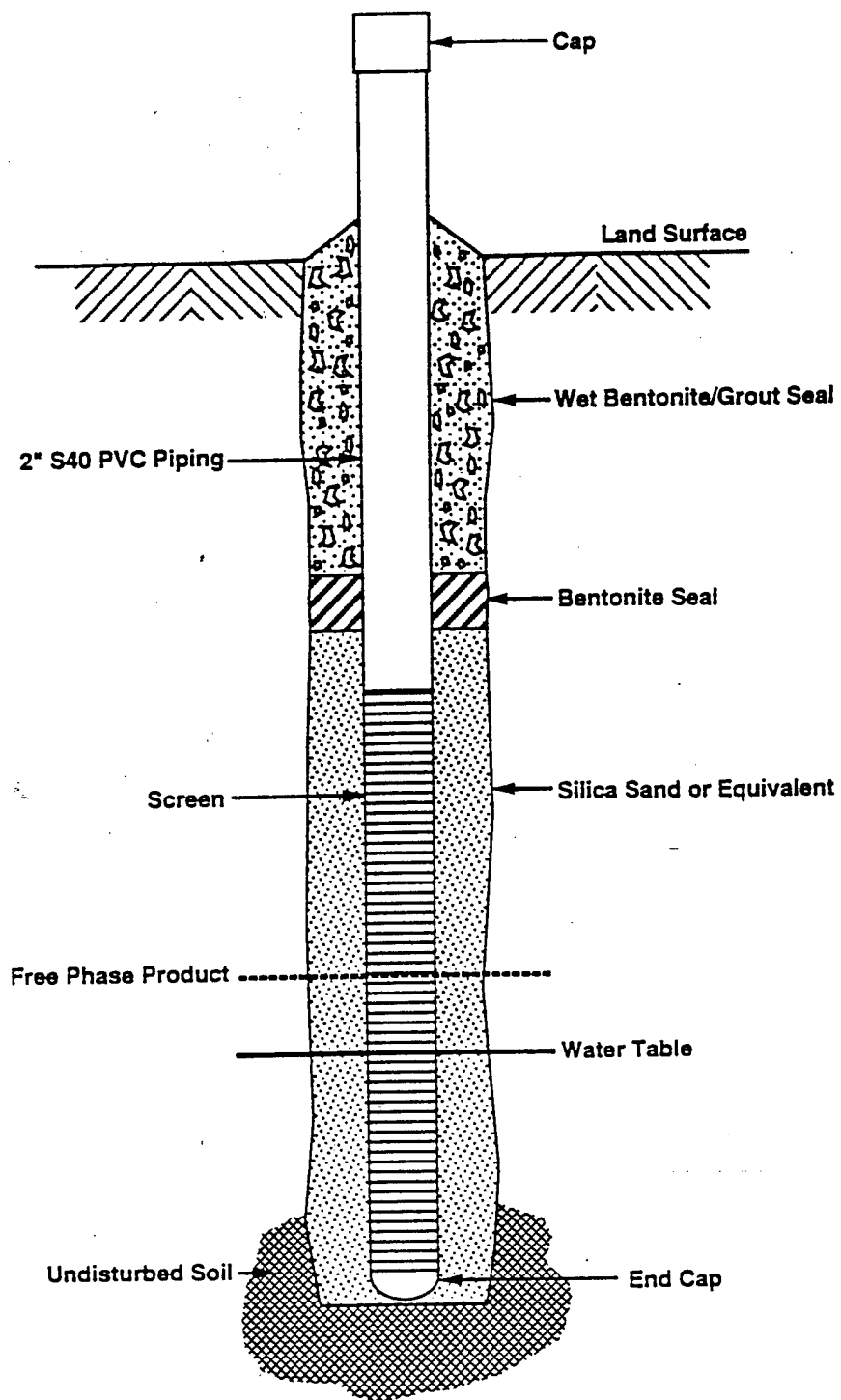

Figure 9. Diagram of a Typical Bioslurper Well

3.3.3 System Startup and Test Operations

After installation is complete and the bioslurper system is confirmed to be operating properly, the LNAPL recovery tests will be started. The Bioslurper Initiative has been designed to evaluate the effectiveness of bioslurping as an LNAPL recovery technology relative to conventional gravity-driven LNAPL recovery technologies. The Bioslurper Initiative includes three separate LNAPL recovery tests: (1) a skimmer simulation test, (2) a vacuum-assisted bioslurper test, and (3) a groundwater drawdown LNAPL recovery test. The three recovery tests are described in detail in Section 7.3 of the generic Bioslurping Protocol.

The bioslurper system operating parameters that will be measured during operation are vapor discharge, aqueous effluent, LNAPL recovery volume rates, vapor discharge volume rates, and groundwater discharge volume rates. Vapor monitoring will consist of continuous on-line monitoring of TPH supplemented by two samples collected for detailed laboratory analysis. A total of two samples of aqueous effluent will be collected for analysis of BTEX and TPH content. Recovered LNAPL volume will be recorded using an in-line flow-totalizing meter. The off-gas discharge volume will be measured using a calibrated pilot tube, and groundwater discharge volume will be recorded using an in-line flow-totalizing meter. Section 8.0 of the generic Bioslurping Protocol describes process monitoring of the bioslurper system.

3.3.4 Soil-Gas Permeability Test

A soil-gas permeability test will be conducted concurrently with startup of the vacuum-assisted bioslurper operation. Soil-gas permeability data will support the process of estimating the vadose zone radius of influence of the bioslurper system. Soil-gas permeability results also will aid in determining the number of wells required if it is decided to treat the site with a large-scale bioslurper system. The soil-gas permeability test method is described in Section 5.7 of the generic Bioslurping Protocol.

3.3.5 In Situ Respiration Test

The oxygen utilization rate will be used to estimate the biodegradation rate at the site. An in situ respiration test will be conducted after completion of the bioslurper operating tests. The in situ respiration testing will involve injection of air/helium into selected soil-gas monitoring points followed by monitoring changes in concentration of oxygen, carbon dioxide, petroleum hydrocarbons, and helium in soil-gas near the injection point. Measurement of the soil-gas composition typically will be conducted at 2, 4, 6, and 8 hours and then every 4 to 12 hours for about 2 days. Timing of the tests will be adjusted based on oxygen-use rate. If oxygen depletion occurs rapidly, more frequent monitoring will be required. If oxygen depletion is slow, less frequent readings will be acceptable. Further information on the procedures and data collection for in situ respiration testing is given in Section 5.8 of the generic Bioslurping Protocol.

3.3.6 Extended Testing

The Air Force has the option of extending the operation of the bioslurper system for up to 6 months if LNAPL recovery rates are promising. If extended testing is to be performed, the Air Force will need to provide electrical power for long-term operation of the bioslurper pump. Disposition of all generated wastes and routine operation and maintenance of the system will be the Air Force's responsibility. Battelle will provide technical support during the extended testing operation.

3.4 Demobilization

Once all necessary tests have been completed at the Seymour Johnson AFB site, the equipment will be disassembled by Battelle staff. The equipment will then be moved back to the holding facility, where it will remain until its next destination is determined. Battelle staff will receive this information and will be responsible for shipment of the equipment to the next site before departing from Seymour Johnson AFB.

4.0 BIOSLURPER SYSTEM DISCHARGE

4.1 Vapor Discharge Disposition

Battelle expects that the operation of the bioslurper test system at the Seymour Johnson AFB site may require a waiver or a point source air release registration and may require some additional permits. Due to the short duration of the bioslurper pilot test (approximately 2 weeks), discharge of vapors directly to the atmosphere may be allowed.

The concentration of petroleum hydrocarbon constituents in the bioslurper discharge varies widely. The fuel type, degree of weathering and soil permeability all factor heavily into the discharge concentration. The data for the TPH and benzene discharge levels at four previous bioslurper sites are presented in Table 6. The actual concentration during the Seymour Johnson bioslurper pilot test is expected to be in the range observed at Wright-Patterson AFB and Travis AFB.

Table 6. Benzene and TPH Discharge Levels at Previous Bioslurper Test Sites

Site Location	Fuel Type	Extraction Rate (scfm)	Benzene (ppmv)	TPH (ppmv)	Benzene Discharge (lb/day)	TPH ^(a) Discharge (lb/day)
Wright-Patterson AFB	Jet Fuel	3	nd ^(a)	595	0.0	1.0
Bolling AFB (Site #1)	No. 2 Fuel Oil	4	0.2	153	0.0003	0.009
Bolling AFB (Site #2)	Gasoline	21	370	70,000	2.3	470.1
Andrews	No. 2 Fuel Oil	8	16	2,000	0.001	0.2
Travis AFB	Jet Fuel	20	100	10,800	0.58	126.4

^(a)nd = not detected.

To ensure the safety and regulatory compliance of the bioslurper system, vapor discharge samples (TPH, O₂, and CO₂) will be collected periodically throughout the bioslurper pilot test, and field soil-gas screening instruments will be used to monitor vapor discharge concentration variability. The volume of vapor discharge will be monitored daily using air flow instruments. If state regulatory requirements will not permit the expected amount of organic vapor discharge to the atmosphere, the Base Point of Contact (POC) should inform AFCEE and Battelle so that alternative plans can be made prior to mobilization to the site. Table 7 presents information typically required to complete an air release registration form.

Table 7. Air Release Summary Information

Data Item	Air Release Information
Contractor Point of Contact	Jeff Kittel, (614) 424-6122
Contractor address	Battelle, 505 King Avenue, Columbus, OH 43201
Estimated total quantity of petroleum product to be recovered	TBD
Description of petroleum product to be recovered	JP-4 jet fuel
Planned date of test start	TBD
Test duration	9 days (active pumping)
Maximum expected VOC concentration in air	~125 lb/day (64 lb TPH, <1.0 lb benzene)
Maximum total quantity of VOC release	~125 lb/day
Expected contaminants in air release	TPH, benzene
Expected quantity of fuel use (for electrical generator)	125 gallons
Type of fuel used	Gasoline and diesel fuel
Stack height above ground level	10 ft

4.2 Aqueous Influent/Effluent Disposition

The flowrate of groundwater pumped by the bioslurper will be less than 5 gpm. However, it may be necessary in North Carolina to obtain a groundwater pumping waiver or registration permit. If one is required, the base POC will inform Battelle of the necessary steps in obtaining the waiver or permit.

Operation of the bioslurper system will generate an aqueous waste discharge that will be passed through an oil/water separator. The intention of Battelle staff will be to dispose of the wastewater by discharging directly to the Base sanitary sewer system or into a large holding tank for later disposal by the Air Force. If existing Base wastewater channels can be used, no National Pollutant Discharge Elimination System (NPDES) or other water discharge permits will be required.

4.3 Free-Product Recovery Disposition

The bioslurper system will recover free-phase product from the pilot tests performed at Seymour Johnson AFB. Free product recovered by the bioslurping tests will be turned over to the Base for disposal and/or recycling. The volume of free product recovered from the Base will not be known until the tests have been performed. The maximum recovery rate for this system is 5 gpm, but the actual rate of LNAPL recovery likely will be much lower.

5.0 SCHEDULE

The schedule for the bioslurper fieldwork at Seymour Johnson AFB will depend on approval of the project test plans. Battelle will determine a definitive schedule as soon as possible after approval is received. Battelle will have two to three staff members on site for approximately 2 weeks to conduct all necessary pilot testing. At the conclusion of the field testing at Seymour Johnson AFB, all staff will return their Base passes. Battelle staff will remove all bioslurper field testing equipment from the Base before they leave the site.

6.0 PROJECT SUPPORT ROLES

This section outlines some of the major functions of personnel from Battelle, Seymour Johnson AFB, and AFCEE during the bioslurper field test.

6.1 Battelle Activities

Battelle's responsibility in the Bioslurper Initiative at Seymour Johnson AFB will be to supply all necessary staff and equipment to perform all the tests on the bioslurper system. Battelle also will provide technical support in the areas of water and vapor discharge permitting, digging permits, staff support during the extended testing period, and any other technical areas that need to be addressed.

6.2 Seymour Johnson AFB Support Activities

To support the necessary field tests at Seymour Johnson AFB, the Base must be able to provide the following:

1. Any digging permits and utility clearances that need to be obtained prior to the initiation of the fieldwork. Any underground utilities should be clearly marked to reduce the chance of utility damage and/or personal injury during soil-gas probe and possible well installation. Battelle will not begin field operations without these clearances and permits.
2. The Air Force will be responsible for obtaining Base and site clearance for the Battelle staff that will be working at the Base. The Base POC will be furnished with all necessary information on each staff member at least 1 week prior to field startup.
3. Access to the local sanitary sewer must be furnished so that Battelle staff can discharge the bioslurper aqueous effluent directly to the Base treatment facility. If discharge water is stored on site, the base will be responsible for final disposition.
4. Regulatory approval, if required, must be obtained by the Base POC prior to startup of the bioslurper pilot test. The Base POC will obtain all necessary Base permits prior to mobilization to the site. Battelle will provide technical assistance in preparing regulatory approval documents.
5. The Base also will be responsible for the disposition of all waste generated from the pilot testing. Such waste includes any soil cuttings generated from drilling, and all aqueous waste streams produced from the bioslurper tests. All free product recovered from the bioslurper operation will be disposed of or recycled by the Base. Battelle will provide technical assistance in disposing of the waste generated from the bioslurper pilot test.
6. Before field activities begin, the Health and Safety Plan will be finalized with information provided by the Base POC. Table 8 is a checklist for the information required to complete the Health and Safety Plan. All emergency information will be obtained by the Site Health and Safety Office before operations begin.

Table 8. Health and Safety Information Checklist

<u>Emergency Contacts</u>	<u>Name</u>	<u>Telephone Number</u>
Hospital Emergency Room:	Medical Officer	919-736-6911 (or 911)
Point of Contact:	Greg Ditzler	919-736-6501
Fire Department:	Fire/Spill Officer	919-736-6911 (or 911)
Emergency Unit (Ambulance):		911
Security:		
Explosives Unit:	Fire Department	919-736-6911 (or 911)
Community Emergency Response Coordinator:		
Other:		
<u>Program Contacts</u>		
Air Force:	Patrick Haas	210-536-4314
Battelle:	Jeff Kittel	614-424-6122
Other:		
<u>Emergency Routes</u>		
Hospital map (Figure 10)		
Other:	_____	

6.3 AFCEE Activities

The Air Force Center for Environmental Excellence (AFCEE) POC will act as a liaison between Battelle and Seymour Johnson Base staff. The AFCEE POC will ensure that all necessary permits are obtained and the space required to house the bioslurper field equipment is found. The following is a listing of Battelle, AFCEE, and Seymour Johnson Base staff who can be contacted in cases of emergency and/or required technical support during the bioslurper field initiative tests at Seymour Johnson AFB.

Battelle POCs	Jeff Kittel	614-424-6122
AFCEE POC	Patrick Haas	210-536-4314
Seymour Johnson AFB POC	<u>Greg Ditzler</u>	<u>919-736-6501</u>
Regulator POCs		
Air:	_____	_____
Water:	_____	_____

APPENDIX A

**BORING RECORDS FOR MONITORING WELLS
SITE SS-04, SEYMOUR JOHNSON AFB**

TYPE I PIEZOMETER INSTALLATION DIAGRAM



LAW ENVIRONMENTAL, INC.
 GOVERNMENT SERVICES DIVISION
 KENNESAW, GEORGIA

WELL NO. P-5 JOB NO. 11-0657
 JOB NAME SEYMOUR JOHNSON AFB
 DATE 4-25-91 TIME 0905
 WELL LOCATION NW CORNER OF POL YARD-SITE 14

GROUND SURFACE ELEVATION 93.79' DRILLING TECHNIQUE AUGER
 TOP OF SCREEN ELEVATION 89.59' AUGUR SIZE AND TYPE 8" HOLLOW STEM
 REFERENCE POINT ELEVATION 93.64' (TOC)
 TYPE SAND PACK SILCA POOL FILTER SAND GRADATION 10-40 BOREHOLE DIAMETER 8"
 SAND PACK MANUFACTURER BH & JH, INC. SCREEN DIAMETER 2.0" ID SLOT SIZE 0.010"
 SCREEN MATERIAL SLOTTED THREADED SCHEDULE 40 PVC LAW ENVIRONMENTAL, INC. CHRIS KNOCHE
 MANUFACTURER TRI LOCK FIELD REPRESENTATIVE _____
 RISER MATERIAL THREADED SCHEDULE 40 PVC DRILLING CONTRACTOR LAW ENGINEERING
 MANUFACTURER TRI LOCK AMOUNT SAND USED 2-100 LB. BAGS
 RISER DIAMETER 2.0" ID STATIC WATER DEPTH (after dev.) 6.24' (TOC) 5/16/91
 STRATUM SCREENED INTO THE SURFICIAL AQUIFER

(NOT TO SCALE)

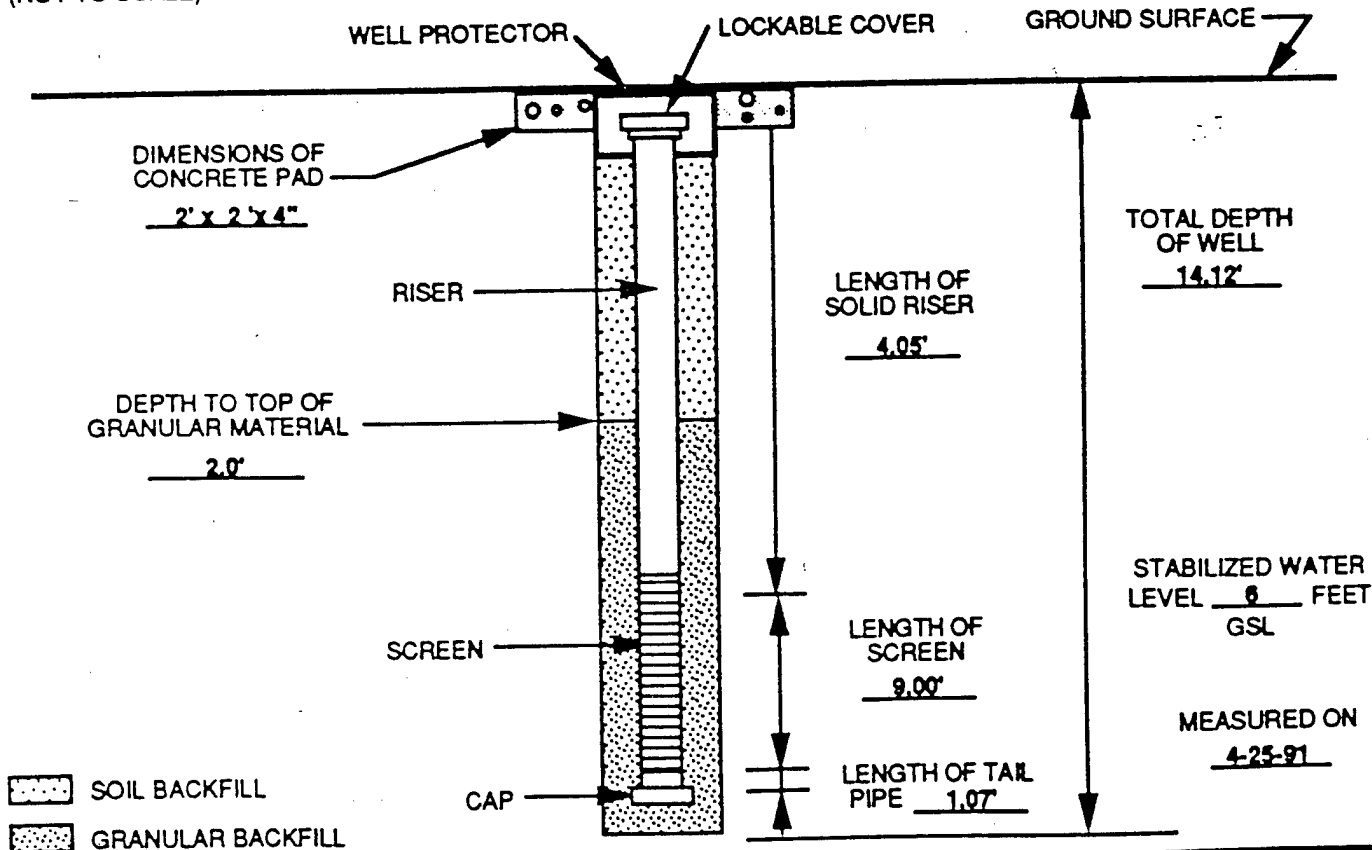

QA / QC

INSTALLED BY: WAYNE MELVIN INSTALLATION OBSERVED BY: CHRIS KNOCHE
 DISCREPANCIES: _____

TYPE II MONITORING WELL INSTALLATION DIAGRAM



LAW ENVIRONMENTAL, INC.
 GOVERNMENT SERVICES DIVISION
 KENNESAW, GEORGIA

JOB NAME SEYMOUR JOHNSON AFB
 WELL NO. MW-1502a JOB NO. 11-0657
 DATE 2-25-91 TIME 1600
 WELL LOCATION SITE 15. PUMP HOUSE NO. 1

GROUND SURFACE ELEVATION <u>75.33'</u>	BENTONITE TYPE <u>3/8" PELLETS</u>
TOP OF SCREEN ELEVATION <u>72.31'</u>	MANUFACTURER <u>BRAINARD-KILMAN</u>
REFERENCE POINT ELEVATION <u>77.89' (TOC)</u>	CEMENT TYPE <u>PORTLAND CEMENT TYPE I</u>
TYPE SAND PACK <u>SILICA POOL FILTER SAND</u> GRADATION <u>10-40</u>	MANUFACTURER <u>COPLAY</u>
SAND PACK MANUFACTURER <u>BH & JH, INC.</u>	BOREHOLE DIAMETER <u>8"</u>
SCREEN MATERIAL <u>CONTINUOUS SLOT THREADED 304 STAINLESS STEEL</u>	SCREEN DIAMETER <u>1 7/8" ID</u> SLOT SIZE <u>0.010"</u>
MANUFACTURER <u>TRI LOCK</u>	LAW ENVIRONMENTAL, INC. FIELD REPRESENTATIVE <u>JEFF LEHMAN, CHRIS KNOCHE</u>
RISER MATERIAL <u>THREADED 304 STAINLESS STEEL</u>	DRILLING CONTRACTOR <u>LAW ENGINEERING</u>
MANUFACTURER <u>TRI LOCK</u>	AMOUNT BENTONITE USED <u>1/2 OF 5 GALLON BUCKET</u>
RISER DIAMETER <u>2.0" I.D.</u>	AMOUNT CEMENT USED <u>3-94 lb. BAGS</u>
DRILLING TECHNIQUE <u>HOLLOW STEM AUGER</u>	AMOUNT SAND USED <u>5-50 lb. BAGS</u>
AUGUR SIZE AND TYPE <u>8" HOLLOW STEM</u>	STATIC WATER DEPTH (after dev.) <u>10.27' (TOC) 3-21-91</u>
STRATUM <u>SCREENED INTO THE SURFICIAL AQUIFER</u> (feet)	

(NOT TO SCALE)

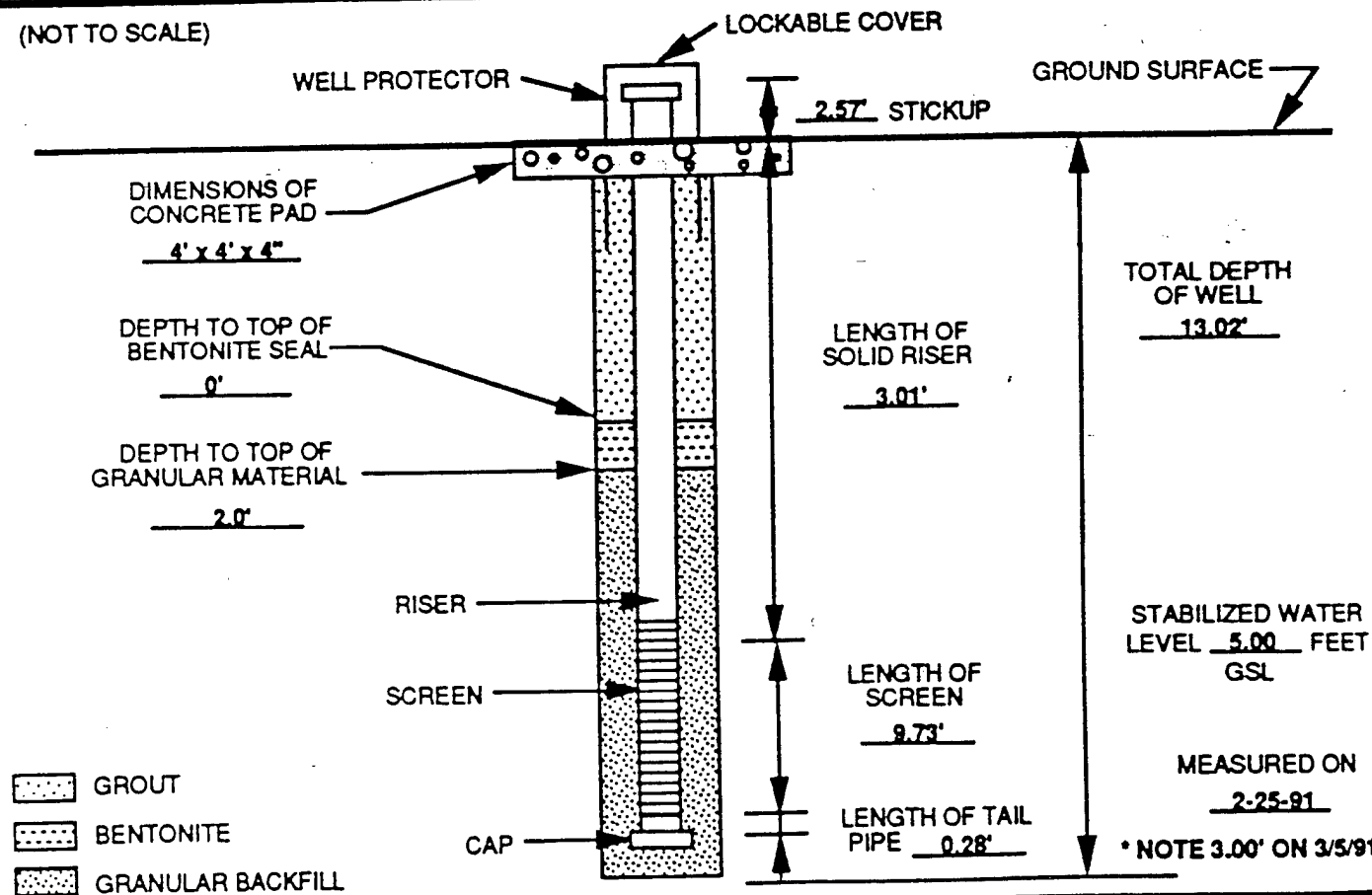

QA / QC

INSTALLED BY: WAYNE MELVIN INSTALLATION OBSERVED BY: JEFF LEHMAN
 DISCREPANCIES: PRODUCT DEPTH 6.26' (TOC) 3/21/91; (PRODUCT THICKNESS: 4.01')

TYPE II MONITORING WELL INSTALLATION DIAGRAM



LAW ENVIRONMENTAL, INC.
 GOVERNMENT SERVICES DIVISION
 KENNESAW, GEORGIA

JOB NAME SEYMOUR JOHNSON AFB
 WELL NO. MW-1504 JOB NO. 11-0657
 DATE 2-25-91 TIME _____
 WELL LOCATION SITE 15, PUMP HOUSE NO. 2

GROUND SURFACE ELEVATION <u>81.80'</u> TOP OF SCREEN ELEVATION <u>74.97'</u> REFERENCE POINT ELEVATION <u>84.08' (TOC)</u> TYPE SAND PACK <u>SILICA POOL FILTER SAND</u> GRADATION <u>10-40</u> SAND PACK MANUFACTURER <u>BH & JH, INC.</u> SCREEN MATERIAL <u>CONTINUOUS SLOT THREADED SCHEDULE 40 PVC</u> MANUFACTURER <u>TRI LOCK</u> RISER MATERIAL <u>THREADED SCHEDULE 40 PVC</u> MANUFACTURER <u>TRI LOCK</u> RISER DIAMETER <u>2.0" I.D.</u> DRILLING TECHNIQUE <u>AUGER</u> AUGUR SIZE AND TYPE <u>8" HOLLOW STEM</u> STRATUM <u>SCREENED INTO THE SURFICIAL AQUIFER</u> (feet) _____	BENTONITE TYPE <u>3/8" PELLETS</u> MANUFACTURER <u>BRAINARD-KILMAN</u> CEMENT TYPE <u>PORTLAND TYPE I</u> MANUFACTURER <u>COPLAY</u> BOREHOLE DIAMETER <u>8"</u> SCREEN DIAMETER <u>1 7/8" ID</u> SLOT SIZE <u>0.010"</u> LAW ENVIRONMENTAL, INC. FIELD REPRESENTATIVE <u>CHRIS KNOCHE</u> DRILLING CONTRACTOR <u>LAW ENGINEERING</u> AMOUNT BENTONITE USED <u>1/2- 5 GALLON BUCKET</u> AMOUNT CEMENT USED <u>3-94 lb. BAGS</u> AMOUNT SAND USED <u>5-50 lb. BAGS</u> STATIC WATER DEPTH (after dev.) <u>11.89' (TOC) 3-21-91</u>
---	---

(NOT TO SCALE)

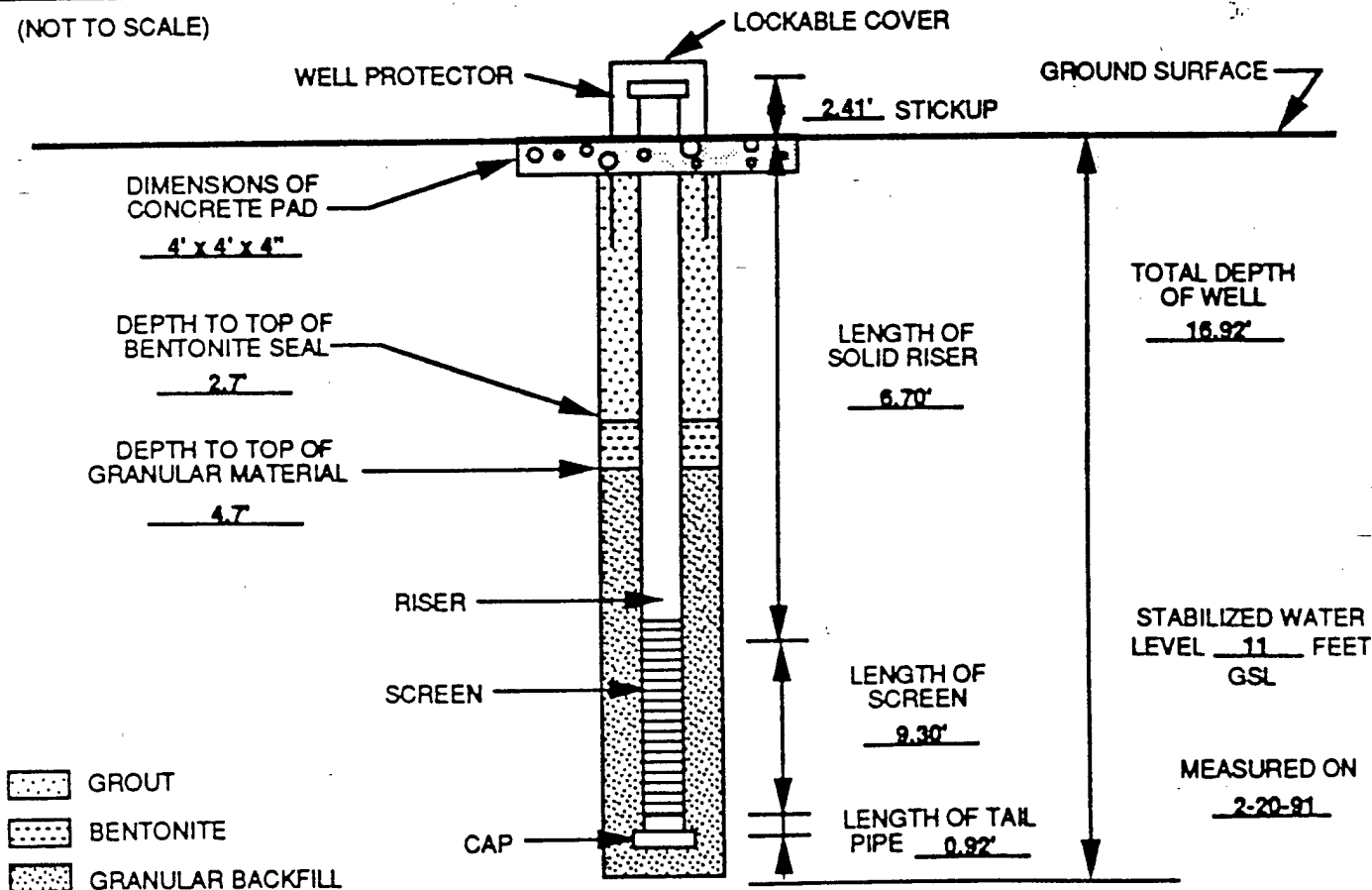

QA / QC

INSTALLED BY: WAYNE MELVIN INSTALLATION OBSERVED BY: CHRIS KNOCHE
 DISCREPANCIES: _____

TYPE II MONITORING WELL INSTALLATION DIAGRAM



LAW ENVIRONMENTAL, INC.
 GOVERNMENT SERVICES DIVISION
 KENNESAW, GEORGIA

JOB NAME SEYMOUR JOHNSON AFB
 WELL NO. MW-1506 JOB NO. 11-0657
 DATE 2-25-91 TIME 11:55
 WELL LOCATION SOUTH OF E-W RUNWAY

GROUND SURFACE ELEVATION <u>72.58'</u>	BENTONITE TYPE <u>3/8" PELLETS</u>
TOP OF SCREEN ELEVATION <u>64.28'</u>	MANUFACTURER <u>BRAINARD-KILMAN</u>
REFERENCE POINT ELEVATION <u>74.68' (TOC)</u>	CEMENT TYPE <u>PORTLAND CEMENT TYPE I</u>
TYPE SAND PACK <u>SILICA POOL FILTER SAND</u> GRADATION <u>10-40</u>	MANUFACTURER <u>COPLAY</u>
SAND PACK MANUFACTURER <u>BH & JH, INC.</u>	BOREHOLE DIAMETER <u>8"</u>
SCREEN MATERIAL <u>THREADED SCHEDULE 40 PVC CONTINUOUS SLOT</u>	SCREEN DIAMETER <u>1 7/8" ID</u> SLOT SIZE <u>0.010"</u>
MANUFACTURER <u>TRI LOCK</u>	LAW ENVIRONMENTAL, INC.
RISER MATERIAL <u>THREADED SCHEDULE 40 PVC</u>	FIELD REPRESENTATIVE <u>JEFF LEHMAN, CHRIS KNOCH</u>
MANUFACTURER <u>TRI LOCK</u>	DRILLING CONTRACTOR <u>LAW ENGINEERING</u>
RISER DIAMETER <u>2.0" ID</u>	AMOUNT BENTONITE USED <u>1/2 OF 5 GALLON BUCKET</u>
DRILLING TECHNIQUE <u>HOLLOW STEM AUGER</u>	AMOUNT CEMENT USED <u>3-94 lb. BAGS</u>
AUGUR SIZE AND TYPE <u>8" HOLLOW STEM</u>	AMOUNT SAND USED <u>6-50 lb. BAGS</u>
STRATUM <u>SCREENED IN THE SURFICIAL AQUIFER</u>	STATIC WATER DEPTH (after dev.) <u>13.95' (TOC) 3-21-91</u>
(feet)	

(NOT TO SCALE)

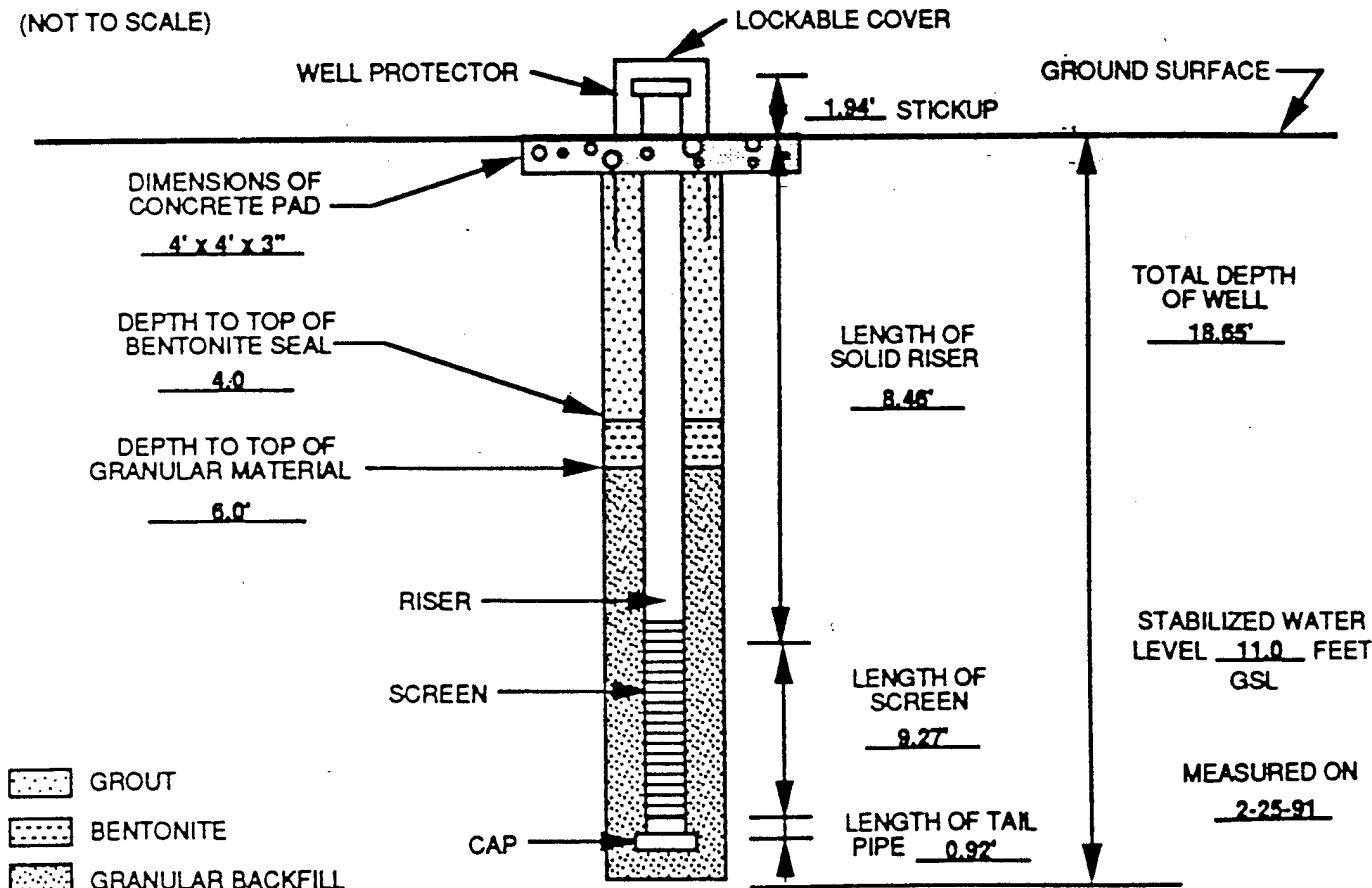

QA / QC

INSTALLED BY: WAYNE MELVIN INSTALLATION OBSERVED BY: JEFF LEHMAN
 DISCREPANCIES: _____

TYPE II MONITORING WELL INSTALLATION DIAGRAM



LAW ENVIRONMENTAL, INC.
 GOVERNMENT SERVICES DIVISION
 KENNESAW, GEORGIA

JOB NAME SEYMOUR JOHNSON AFB
 WELL NO. MW-1508a JOB NO. 11-0657
 DATE 2-26-91 TIME 8:45 - 9:20
 WELL LOCATION SITE 15, PUMP HOUSE NO. 1

GROUND SURFACE ELEVATION <u>75.13'</u> TOP OF SCREEN ELEVATION <u>72.21'</u> REFERENCE POINT ELEVATION <u>77.51' (TOC)</u> TYPE SAND PACK <u>SILICA POOL FILTER SAND</u> GRADATION <u>10-40</u> SAND PACK MANUFACTURER <u>BH & JH, INC.</u> SCREEN MATERIAL <u>CONTINUOUS SLOT 304 STAINLESS STEEL THREADED</u> MANUFACTURER <u>TRI LOCK</u> RISER MATERIAL <u>304 STAINLESS STEEL THREADED</u> MANUFACTURER <u>TRI LOCK</u> RISER DIAMETER <u>2.0" I.D.</u> DRILLING TECHNIQUE <u>HOLLOW STEM AUGER</u> AUGUR SIZE AND TYPE <u>8" HOLLOW STEM</u> STRATUM <u>SCREENED INTO THE SURFICIAL AQUIFER</u> (feet)	BENTONITE TYPE <u>3/8" PELLETS</u> MANUFACTURER <u>BRAINARD-KILMAN</u> CEMENT TYPE <u>PORTLAND TYPE I</u> MANUFACTURER <u>COPLAY</u> BOREHOLE DIAMETER <u>8"</u> SCREEN DIAMETER <u>1 7/8" ID</u> SLOT SIZE <u>0.010"</u> LAW ENVIRONMENTAL, INC. FIELD REPRESENTATIVE <u>JEFF LEHMAN CHRIS KNOCHE</u> DRILLING CONTRACTOR <u>LAW ENGINEERING</u> AMOUNT BENTONITE USED <u>1/2-5 GALLON BUCKET</u> AMOUNT CEMENT USED <u>3-94 lb. BAGS</u> AMOUNT SAND USED <u>3-50 lb. BAGS</u> STATIC WATER DEPTH (after dev.) <u>9.75' (TOC) 3-21-91</u>
---	---

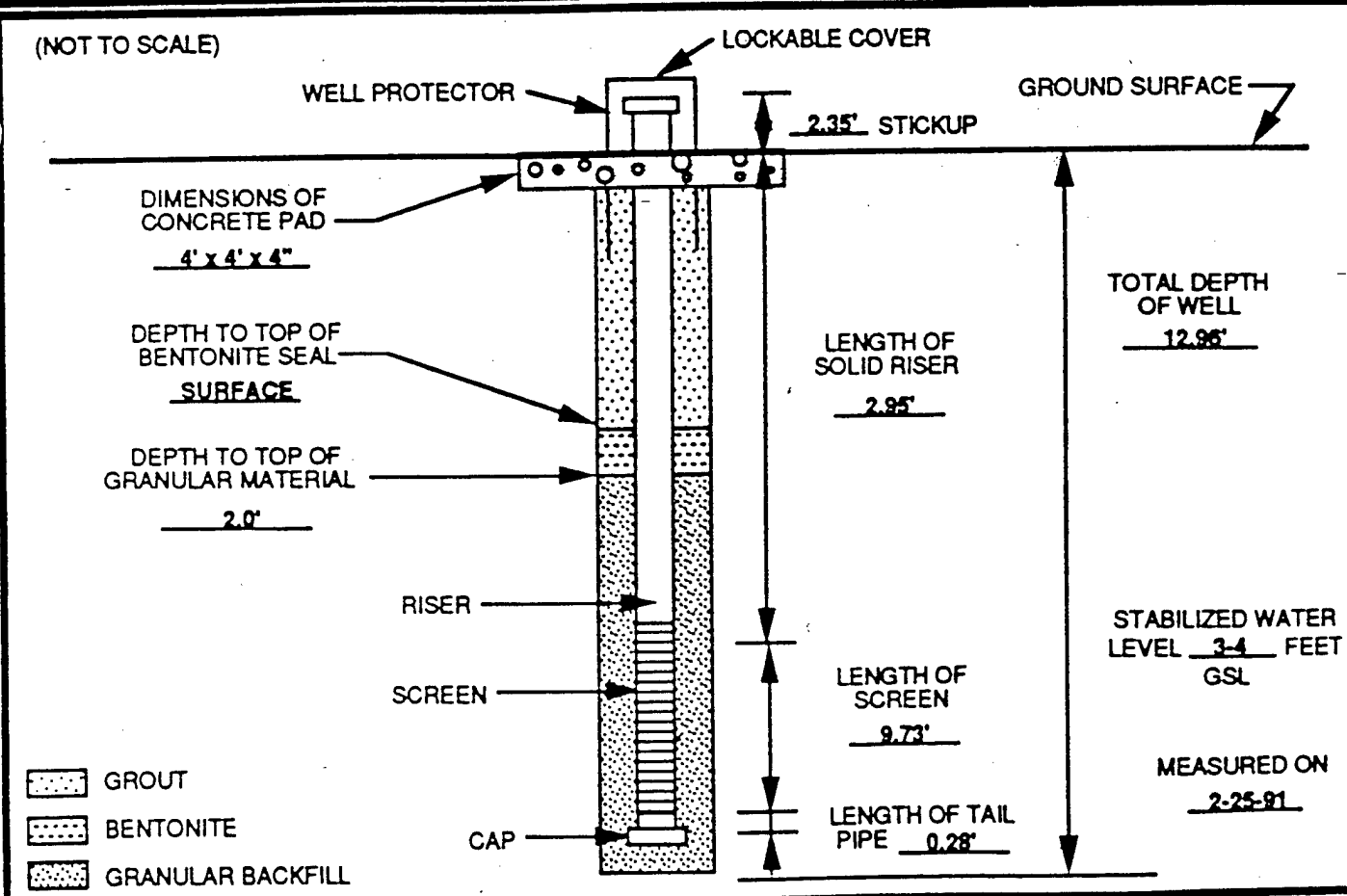

QA / QC	INSTALLED BY: <u>WAYNE MELVIN</u> INSTALLATION OBSERVED BY: <u>JEFF LEHMAN CHRIS KNOCHE</u>	DISCREPANCIES: <u>DEPTH TO PRODUCT: 6.08' (TOC) (PRODUCT THICKNESS: 3.67')</u>
----------------	---	--

TYPE II MONITORING WELL INSTALLATION DIAGRAM



LAW ENVIRONMENTAL, INC.
 GOVERNMENT SERVICES DIVISION
 KENNESAW, GEORGIA

JOB NAME SEYMOUR JOHNSON AFB
 WELL NO. MW-1510a JOB NO. 11-0657
 DATE 2-25-91 TIME 3:00 P.M.
 WELL LOCATION SITE 15, PUMP HOUSE NO. 1

GROUND SURFACE ELEVATION <u>76.39'</u> TOP OF SCREEN ELEVATION <u>73.43'</u> REFERENCE POINT ELEVATION <u>78.87' (TOC)</u> TYPE SAND PACK <u>SILICA POOL FILTER SAND</u> GRADATION <u>10-40</u> SAND PACK MANUFACTURER <u>BH & JH, INC.</u> SCREEN MATERIAL <u>304 STAINLESS STEEL CONTINUOUS SLOT THREADED</u> MANUFACTURER <u>TRI LOCK</u> RISER MATERIAL <u>304 STAINLESS STEEL THREADED</u> MANUFACTURER <u>TRI LOCK</u> RISER DIAMETER <u>2.0" I.D.</u> DRILLING TECHNIQUE <u>HOLLOW STEM AUGER</u> AUGUR SIZE AND TYPE <u>8" HOLLOW STEM</u> STRATUM <u>SCREENED INTO THE SURFICIAL AQUIFER</u> (feet)	BENTONITE TYPE <u>3/8" PELLETS</u> MANUFACTURER <u>BRAINARD-KILMAN</u> CEMENT TYPE <u>PORTLAND TYPE I</u> MANUFACTURER <u>COPLAY</u> BOREHOLE DIAMETER <u>8"</u> SCREEN DIAMETER <u>1 7/8" ID</u> SLOT SIZE <u>0.010"</u> LAW ENVIRONMENTAL, INC. FIELD REPRESENTATIVE <u>JEFF LEHMAN, CHRIS KNOCHE</u> DRILLING CONTRACTOR <u>LAW ENGINEERING</u> AMOUNT BENTONITE USED <u>3/4-5 GALLON BUCKET</u> AMOUNT CEMENT USED <u>3-94 lb. BAGS</u> AMOUNT SAND USED <u>3-50 lb. BAGS</u> STATIC WATER DEPTH (after dev.) <u>10.57' (TOC) 3-21-91</u>
---	---

(NOT TO SCALE)

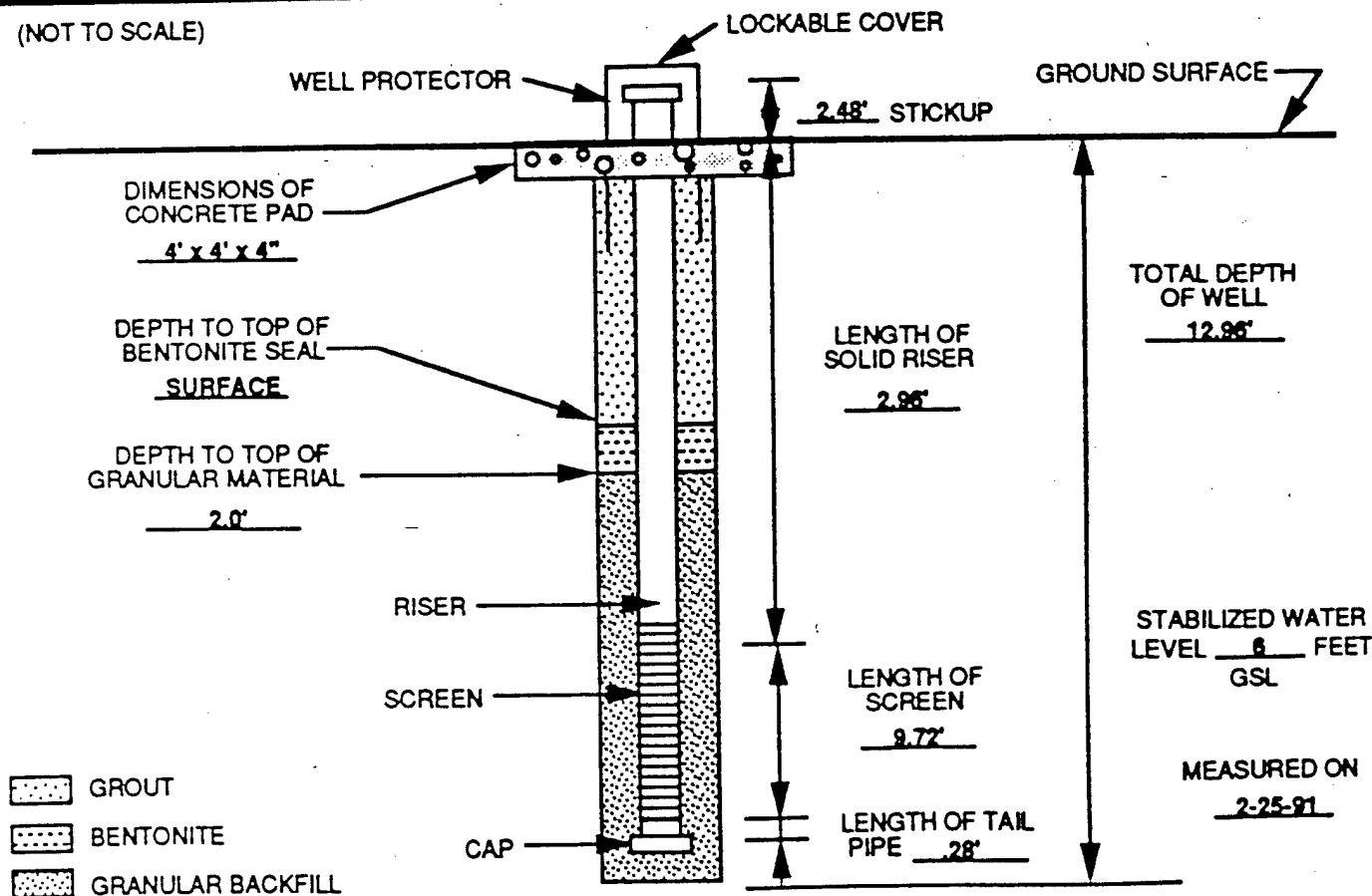

QA / QC

INSTALLED BY: WAYNE MELVIN INSTALLATION OBSERVED BY: JEFF LEHMAN
 DISCREPANCIES: DEPTH TO PRODUCT: 7.28' (PRODUCT THICKNESS: 3.29')

TYPE II MONITORING WELL INSTALLATION DIAGRAM



LAW ENVIRONMENTAL, INC.
 GOVERNMENT SERVICES DIVISION
 KENNESAW, GEORGIA

JOB NAME SEYMOUR JOHNSON AFB
 WELL NO. MW-1512 JOB NO. 11-0657
 DATE 2-25-91 TIME 1040
 WELL LOCATION PUMP HOUSE NO. 1

GROUND SURFACE ELEVATION <u>75.04'</u> TOP OF SCREEN ELEVATION <u>71.16'</u> REFERENCE POINT ELEVATION <u>76.56'</u> TYPE SAND PACK <u>SILICA POOL FILTER SAND</u> GRADATION <u>10-40</u> SAND PACK MANUFACTURER <u>BH & JH, INC.</u> SCREEN MATERIAL <u>CONTINUOUS SLOT SCHEDULE 40 PVC THREADED</u> MANUFACTURER <u>TRI LOCK</u> RISER MATERIAL <u>THREADED SCHEDULE 40 PVC</u> MANUFACTURER <u>TRI LOCK</u> RISER DIAMETER <u>2.0" I.D.</u> DRILLING TECHNIQUE <u>AUGER</u> AUGUR SIZE AND TYPE <u>8" HOLLOW STEM</u> STRATUM <u>SCREENED INTO THE SURFICIAL AQUIFER</u> (feet)	BENTONITE TYPE <u>3/8" PELLETS</u> MANUFACTURER <u>BRAINARD-KILMAN</u> CEMENT TYPE <u>PORTLAND TYPE I</u> MANUFACTURER <u>COPLAY</u> BOREHOLE DIAMETER <u>8"</u> SCREEN DIAMETER <u>1.7/8" I.D.</u> SLOT SIZE <u>0.010"</u> LAW ENVIRONMENTAL, INC. FIELD REPRESENTATIVE <u>JEFF LEHMAN</u> DRILLING CONTRACTOR <u>LAW ENGINEERING</u> AMOUNT BENTONITE USED <u>2/3-5 GALLON BUCKET</u> AMOUNT CEMENT USED <u>2-94 lb. BAGS</u> AMOUNT SAND USED <u>3-50 lb. BAGS</u> STATIC WATER DEPTH (after dev.) <u>5.33' (TOC) 3-21-91</u>
---	--

(NOT TO SCALE)

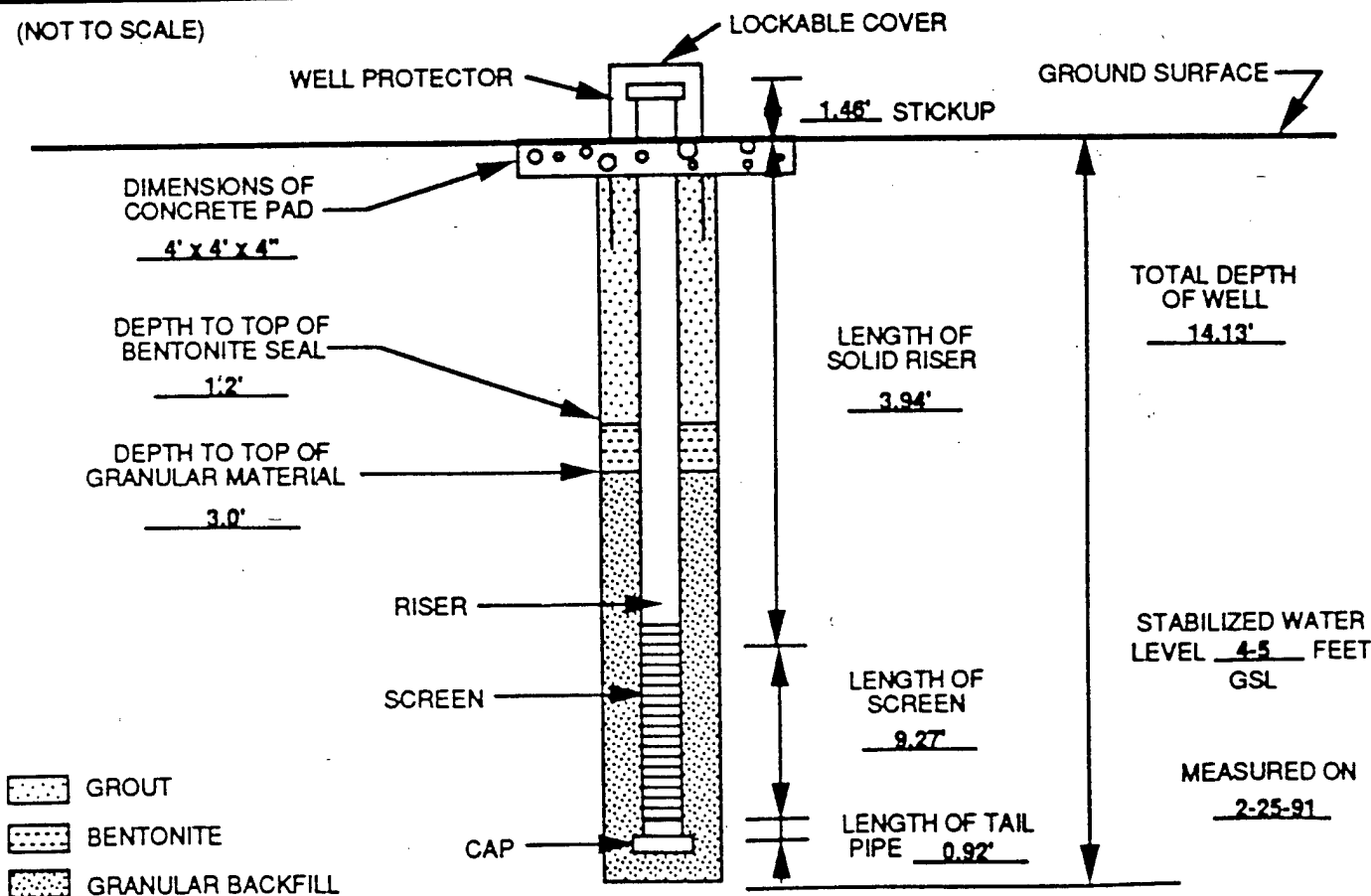



QA / QC

INSTALLED BY: WAYNE MELVIN INSTALLATION OBSERVED BY: JEFF LEHMAN
 DISCREPANCIES: _____

ENVIRONMENTAL INC.
GOVERNMENT SERVICES DIVISION
TEST BORING RECORD

BORING NUMBER MW-1502s
 JOB NUMBER 11-0657
 DATE STARTED 2-25-91
 DATE COMPLETED 2-25-91
 DRILLED BY Wayne Melvin
 LOGGED BY Chris Knoche
 CHECKED BY Kevin Prochaska

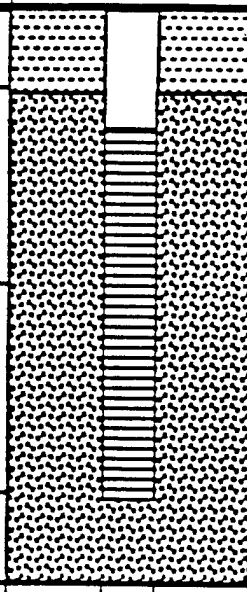
REMARKS: PAGE 1 OF 1
 Depth to G.W. encounter during drilling = 5.0'
 PID readings are located under LAB TESTS
 column in ppm.
 Static water and product levels were measured
 from GSL on 3-21-91.
 Stickup = 2.57

ELEV. IN FEET	DEPTH IN FEET	DESCRIPTION	MONITORING WELL CONSTRUCTION	SYM-BOLS	LAB TESTS	SPT N VALUE
73.33	2.0	Light brownish grey (10 YR6/2) silty (very fine) SAND with heavy organic matter to 0.8 feet (SM-OL)		3.69'  7.70' 	10 GS AL W 90 150	
		Black (10 YR 2/1) silty very fine - fine SAND with minor to significant clay content (SM-SC)				
67.63	7.7	Light grey (10 YR 7/2) Fine-coarse SAND				
62.83	12.5	No Recovery (SP-SW)				
60.33	15.0	Boring Terminated at 15.0'				

LAW ENVIRONMENTAL, INC.
 GOVERNMENT SERVICES DIVISION
TEST BORING RECORD

BORING NUMBER MW-1508s
 JOB NUMBER 11-0657
 DATE STARTED 2-26-91
 DATE COMPLETED 2-26-91
 DRILLED BY Wayne Melvin
 LOGGED BY Jeff Lehman
 CHECKED BY Chris Knoche

REMARKS: PAGE 1 OF 1
 Depth to G.W. encounter during drilling = 3-4'
 PID readings are located under LAB TESTS column
 in units of parts per million (ppm).
 Static water and product levels were measured from
 GSL on 3-21-91.
 Stickup = 2.35'

ELEV. IN FEET	DEPTH IN FEET	DESCRIPTION	MONITORING WELL CONSTRUCTION	SYM- BOLS	LAB TESTS	SPT N VALUE
73.53	1.6	Light grey (10 YR 6/1, 10 YR 7/1) silty (fine-very fine) SAND with organic matter in upper 1' (SM-OL)		3.73' 	GS AL W	
72.53	2.6	Very pale brown (10 YR 8/4) dense clayey SAND to sandy mottled CLAY with yellow (7.5 YR 7/8) (SC/CL) Very dark grey brown silty (fine) SAND				
68.33	5.8	(SM) White (10 YR 8/2) fine-medium SAND with significant amounts of organic material				
66.33	7.8	(SP) No Recovery				
61.13	13.0	Boring Terminated at 13.0'				

LAW ENVIRONMENTAL, INC.
 GOVERNMENT SERVICES DIVISION
TEST BORING RECORD

BORING NUMBER <u> MW-1509d </u> JOB NUMBER <u> 11-0657 </u> DATE STARTED <u> 2-28-91 </u> DATE COMPLETED <u> 3-2-91 </u> DRILLED BY <u> Wayne Melvin </u> LOGGED BY <u> Jeff Lehman </u> CHECKED BY <u> Chris Knoche </u>	REMARKS: PAGE <u> 2 </u> OF <u> 2 </u> Depth to groundwater encountered during drilling at 4-5'. Stickup = 2.66'
---	---

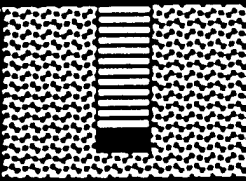
ELEV. IN FEET	DEPTH IN FEET	DESCRIPTION	MONITORING WELL CONSTRUCTION	SYM-BOLS	LAB TESTS	SPT N VALUE
36.78	39.4	Gray 10 YR 5/1 CLAY with minor saturated sand lenses <div style="text-align: right;">(SC-CL)</div>			GS AL W	22
		Boring Terminated at 39.4 feet				

LAW ENVIRONMENTAL, INC.
 GOVERNMENT SERVICES DIVISION
TEST BORING RECORD

BORING NUMBER <u> MW-1511 </u> JOB NUMBER <u> 11-0657 </u> DATE STARTED <u> 2-20-91 </u> DATE COMPLETED <u> 2-20-91 </u> DRILLED BY <u> Wayne Melvin </u> LOGGED BY <u> Jeff Lehman </u> CHECKED BY <u> Chris Knoche </u>	REMARKS: PAGE <u> 1 </u> OF <u> 1 </u> Depth to groundwater encountered at 7.0'. PID readings are recorded in the Lab Tests column in units of parts per million (ppm) Static water level was measured from GSL on 3-21-91. Stickup = 2.45'
---	--

ELEV. IN FEET	DEPTH IN FEET	DESCRIPTION	MONITORING WELL CONSTRUCTION	SYM-BOLS	LAB TESTS	SPT N VALUE
74.75	3.7	Alternating layers of 7.5 YR 2/0 black SILT, 7.5 YR 6/6 reddish-yellow CLAY and silty medium to fine SAND (CL-SC) No Recovery			0	
73.45	5.0	10 YR 6/4 light yellow-brown silty fine SAND to 5 YR 2.5/2 dark reddish-brown fine sandy SILT to 7.5 YR 3/2 dark brown medium to fine SAND (ML-SP)				
68.45	9.8 10.0	No Recovery 7.5 YR 3/2 dark brown to 7.5 YR 6/0 gray medium to fine SAND (SP)				
66.15	12.3	No Recovery				
63.45	15.0	Boring Terminated at 15.0'				

APPENDIX B

**BORING LOGS AND WELL RECORDS
FOR SITE SS-12**

1 COMPANY NAME *IT Corp* 2 DRILLING SUBCONTRACTOR *Summit Drilling Co.* SHEET OF 5 SHEETS

3 PROJECT *Symant Johnson AFB* 4. LOCATION *Site 12*

NAME OF DRILLER *Drilling Dillon* 6. MANUFACTURER'S DESIGNATION OF DRILL *Metric 10" B-80*

7. SIZES AND TYPES OF DRILLING AND SAMPLING EQUIPMENT *2 1/2" x 2 1/2" Sp. Stem* 8. HOLE LOCATION *Taxiway*

3 1/4" I.C. Hollow Stem Auger 9. SURFACE ELEVATION *N/A*

10. DATE STARTED *10/21/92* 11. DATE COMPLETED *10/21/92*

12. OVERBURDEN THICKNESS *> 15 ft.* 15. DEPTH GROUNDWATER ENCOUNTERED *~ 6 ft.*

13. DEPTH DRILLED INTO ROCK *N/A* 16. DEPTH TO WATER AND ELAPSED TIME AFTER DRILLING COMPLETED *5.67' to PRODUCT 11/17/92 N/A PR*
6.03' to WATER

14. TOTAL DEPTH OF HOLE *15 ft.* 17. OTHER WATER LEVEL MEASUREMENTS (SPECIFY) *N/A*

18. GEOTECHNICAL SAMPLES *1* DISTURBED *1* UNDISTURBED *0* 19. TOTAL NUMBER OF CORE BOXES *N/A*

20. SAMPLES FOR CHEMICAL ANALYSIS VOC METALS OTHER (SPECIFY) OTHER (SPECIFY) OTHER (SPECIFY) 21. TOTAL CORE RECOVERY *N/A*

22. DISPOSITION OF HOLE *Monitoring Well* BACKFILLED MONITORING WELL OTHER (SPECIFY) 23. SIGNATURE OF INSPECTOR *R. David [Signature]*

ELE. a	DEPTH b	DESCRIPTION OF MATERIALS c	FIELD SCREENING RESULTS d	GEOTECH SAMPLE OR CORE BOX NO. e	ANALYTICAL SAMPLE NO. f	BLOW COUNTS g	REMARKS h
	1	SAND (SC) 15-20% Clay Fine to Med grained Dry Orange-tan to brown					Spans not collected until 10-15 ft. due to location of boring near taxiway.
	2						
	3						
	4						
	5						

PROJECT *Symant Johnson AFB* HOLE NO *RAW-1*

ELEV. a	DEPTH b	DESCRIPTION OF MATERIALS c	FIELD SCREENING RESULTS d	GEOTECH SAMPLE OR CORE BOX NO e	ANALYTICAL SAMPLE NO f	BLOW COUNTS g	REMARKS h
	15	Coring terminated at 1st Mark place. 5'-0" PVC Riser 2" 15'-5" Screen 2" 20sbt 4'-2" Bentonite Seal 2'-0" Concrete Grout Sand pack 16'-4"					Total Depth From Top of Casing on 11/17/72 14.63 FT

ELEV. a	DEPTH b	DESCRIPTION OF MATERIALS c	FIELD SCREENING RESULTS d	GEOTECH SAMPLE OR CORE BOX NO e	ANALYTICAL SAMPLE NO f	BLOW COUNTS g	REMARKS h
	6	Color change to PINK STRONG Fuel odor					
	7	SAND (SP) Buffs to PINK Poorly sorted Low fines Wet to saturated Fine to Medium grained	OVA No function	MSC	MSC	12 2 13 15	Sampled at 15:30
	9	(coarsening downward separated sample)	OVA No function	MSC MU-2 Geotech	MSC	6 6 13 9	Sampled at 15:35
	10		OVA No function	MU-2 Geotech	MSC	12 13 14 17	Sampled at 15:40
	13	Fine gravels appear in spec.	OVA No function	MU-2 Geotech MSC	MSC	13 8 10 12 14 10	Sampled at 15:45
	14	Color change to Orange-red Clay content increasing					

3 PROJECT **SEYMOUR JOHNSON AFB** 4 LOCATION **Site 12**

NAME OF DRILLER **Summit Drilling** 6. MANUFACTURER'S DESIGNATION OF DRILL **1 1/2" x 2 1/2" 15-50**

7. SIZES AND TYPES OF DRILLING AND SAMPLING EQUIPMENT
 1 1/2" Dia. Hammer
 3 1/4" Hollow Stem Augers
 8. HOLE LOCATION **Taxiway**
 9. SURFACE ELEVATION **N/A**

10. DATE STARTED **10/21/92** 11. DATE COMPLETED **10/21/92**

12. OVERBURDEN THICKNESS **> 15 ft.** 15. DEPTH GROUNDWATER ENCOUNTERED **~ 6 ft.**

13. DEPTH DRILLED INTO ROCK **N/A** 16. DEPTH TO WATER AND ELAPSED TIME AFTER DRILLING COMPLETED
 S.B. TO P202014 **11/14/92** **MTA 7R**
 W.C. TO WATER

14. TOTAL DEPTH OF HOLE **15 ft.** 17. OTHER WATER LEVEL MEASUREMENTS (SPECIFY)
Product thickness 17:20 10/21/92 = 32 ft.

18. GEOTECHNICAL SAMPLES
 DISTURBED UNDISTURBED 19. TOTAL NUMBER OF CORE BOXES **N/A**

20. SAMPLES FOR CHEMICAL ANALYSIS
 VOC METALS OTHER (SPECIFY) **IPA** OTHER (SPECIFY) OTHER (SPECIFY) 21. TOTAL CORE RECOVERY **100%**

22. DISPOSITION OF HOLE **Monitoring Well** BACKFILLED MONITORING WELL OTHER (SPECIFY) 23. SIGNATURE OF INSPECTOR **L. David Oct.**

ELEV. a	DEPTH b	DESCRIPTION OF MATERIALS c	FIELD SCREENING RESULTS d	GEOTECH SAMPLE OR CORE BOX NO. e	ANALYTICAL SAMPLE NO. f	BLOW COUNTS g	REMARKS h
	1	SAND (SC) FINE TO MED. GRAINED Clayey (10-15%) Dry Orange-Brown Loose	LEL = 0% C ₂ = 21.1%	NSC	NSC	3/ 3/ 4/ 3	Sampled at 13:55
	2		LEL = 0% C ₂ = 21.1%				
	3	gray Hydrocarbon Stain Mottled Clayey lens	OVA = 35 ppm	NSC	NSC	9/ 11/ 13/ 7	Sampled at 14:05
	4			NSC	MW-3TH MSO MRC NSC	5. 7. 6. 7	Sampled at 14:10
	5		OVA = 72 ppm				

ELEV. a	DEPTH b	DESCRIPTION OF MATERIALS c	FIELD SCREENING RESULTS d	GEOTECH SAMPLE OR CORE BOX NO e	ANALYTICAL SAMPLE NO f	BLOW COUNTS g	REMARKS h
	5						CONTACT WITH PREVIOUSLY LOGGED Grey-green Clay
	16	11.6' terminated as per Workplan					DEPTH TO TOP OF CASING ON 11/19/92
		10' PVC wrapped Screen 2" 20 slot					14.69 FT
		5' PVC Riser 2"					
		16'-4" Sandpack					
		4'-2" Bentonite Seal					
	17	2'-0" Concrete Grout					
	18						
	19						
	20						

HTW DRILLING LOG

MW-6

1. COMPANY NAME J.T. Corp.		2. DRILLING SUBCONTRACTOR Summit Drilling Co			SHEET 1 OF 1 SHEETS	
PROJECT SEYMOUR JOHNSON APTS			4. LOCATION SS-12			
5. NAME OF DRILLER DERMOT DILLION			6. MANUFACTURER'S DESIGNATION OF DRILL MORICE E.C.			
7. SIZES AND TYPES OF DRILLING AND SAMPLING EQUIPMENT 6 1/4 I.D. HOLLOW STEMS		8. HOLE LOCATION 50 FT UPGRADEMENT OF RECREATION TRENCH				
		9. SURFACE ELEVATION NA				
		10. DATE STARTED 10/26/92		11. DATE COMPLETED 10/26/92		
		12. OVERBURDEN THICKNESS > 15 ft				
13. DEPTH DRILLED INTO ROCK NA		15. DEPTH GROUNDWATER ENCOUNTERED ~ 5 ft				
14. TOTAL DEPTH OF HOLE 15 ft		16. DEPTH TO WATER AND ELAPSED TIME AFTER DRILLING COMPLETED 4.13' TO POINT 6.65' TO WATER 11/17/92				
18. GEOTECHNICAL SAMPLES 0		DISTURBED	UNDISTURBED	19. TOTAL NUMBER OF CORE BOXES 0		
20. SAMPLES FOR CHEMICAL ANALYSIS 0		VOC	METALS	OTHER (SPECIFY)	OTHER (SPECIFY)	OTHER (SPECIFY)
		21. TOTAL CORE RECOVERY NA %				
22. DISPOSITION OF HOLE Monitoring Well		BACKFILLED	MONITORING WELL	OTHER (SPECIFY)	23. SIGNATURE OF INSPECTOR <i>Kenneth J. Ryan Jr</i>	

ELEV.	DEPTH	DESCRIPTION OF MATERIALS	FIELD SCREENING RESULTS	GEOTECH SAMPLE OR CORE BOX NO.	ANALYTICAL SAMPLE NO.	BLOW COUNTS	REMARKS
	5	CUTTINGS FROM HOLLOW STEM AUGERS LOADED					
	10	SAND (SP-SC)	NA	NA	NA	NA	NA
	15	CLAYEY AT SURFACE BECOMING LESS WITH DEPTH					
		B.2.1.1. TERMINATED PER WORK PLAN @ 15 FT Well Construction 0'-5" 4" Ø SS RISER 5'-15" 4" Ø SS SCREEN @ 2" Ø 0'-2" PUTLAMA 2'-4" BENTONITE 4'-15" SAND PACK					TOTAL DEPTH FROM TOP OF CASING ON 11/19/92 14.05 FT.

ELEV. a	DEPTH b	DESCRIPTION OF MATERIALS c	FIELD SCREENING RESULTS d	GEOTECH SAMPLE OR CORE BOX NO e	ANALYTICAL SAMPLE NO f	BLOW COUNTS g	REMARKS h
	6						
	7						
	8						
	9						
	10	<i>SAND (S)</i>					
	11	<i>Medium to coarse Grained Saturated Fine Grains present Lentic angular Grains</i>	<i>O₂ = 0.8% LEL = 0%</i>	<i>NSC</i>	<i>MW-40 13-12'</i>	<i>59/ 40/ 42/ 44</i>	<i>Sampled at 16:30</i>
	12						
	13						
	14						

ELEV a	DEPTH b	DESCRIPTION OF MATERIALS c	FIELD SCREENING RESULTS d	GEOTECH SAMPLE OR CORE BOX NO e	ANALYTICAL SAMPLE NO f	BLOW COUNTS g	REMARKS h	
	24							
	25		LEL = 0.1% CO ₂ = 21.8%		MW-40	2 9 1 10	Sampled at 17:10	
	26		OVA = 1 ppm	NSC	25-27		Set Surface Casing at 25 ft.	
	27							
	28		OVA Multi-function	MW-40 Geotech Sample	NSC	25 39 92 30+	2nd Day 10/21/92 Sampled at 15:55	
	29							
	30	Boring terminated as per Workplan. Surface Casing 0-25' 2" PVC Wrapped Screen 25'-30' 25 Sandpack 31'-24' Bentonite Seal 24'-22' Concrete Grout 22'-0' 3" PVC Pipe 0-25'					TOTAL DEPTH FROM TOP OF CASING ON 11/19/92 29.50 FT	

ELEV. a	DEPTH b	DESCRIPTION OF MATERIALS c	FIELD SCREENING RESULTS d	GEOTECH SAMPLE OR CORE BOX NO e	ANALYTICAL SAMPLE NO f	BLOW COUNTS g	REMARKS h
	6				NSC	N/A	
	7				NSC	N/A	
	8		$O_v = 21.4\%$ $LEL = 2\%$				
	9		$O_v =$ $> 100\%$		B-1 10ft.		Grab Sampled at 7:05
	10	Hole Terminated at 10 ft. - per Workplan.					

PROJECT

Symposium Johnson AFB

INSPECTOR

Emid Asti

SHEET 2 OF 2 SHEETS

ELEV. a	DEPTH b	DESCRIPTION OF MATERIALS c	FIELD SCREENING RESULTS d	GEOTECH SAMPLE OR CORE BOX NO e	ANALYTICAL SAMPLE NO f	BLOW COUNTS g	REMARKS h
	6			NSC		N/A	
	7			NSC		N/A	
	8		Q _d = 21.4% LEL = 2.3%				
	9			NSC	B-2 10 ft.	N/A	Sampled at 09.45
	10		Oil = 20 ppm				
		12 is terminated as per instructions					

PROJECT

Symposium Johnson AFB

HOLE NO

B-2

ELEV.	DEPTH	DESCRIPTION OF MATERIALS	FIELD SCREENING RESULTS	GEOTECH SAMPLE OR CORE BOX NO	ANALYTICAL SAMPLE NO	BLOW COUNTS	REMARKS
	6	Product Encountered	OVA = 3 ppm	NSC	B-3 4-6'	9/12 24/21	Sampled at 10:27
	7		OVA = n/a Stability Sample	NSC	B-3 6'-8'	7/15 16	Sampled at 10:43
	9		OVA = n/a	NSC	B-3 8'-10'	9/12 13/7	Sampled at 10:45
	10	SAND/SP loosely sorted low sand/gravel turn to clay saturated with product cause ground loss					
		Job terminated as per instruction					

ELEV. a	DEPTH b	DESCRIPTION OF MATERIALS c	FIELD SCREENING RESULTS d	GEOTECH SAMPLE OR CORE BOX NO e	ANALYTICAL SAMPLE NO f	BLOW COUNTS g	REMARKS h
	6						
	7		OVN=10ppm	NSC	B-4 6-8'	4 2 12 12	Sampled at 10:15
	8						Obs of Hypocenters
	9	SAND (SP) Medium to Coarse Grained Poorly Sorted Fines <10% Angular Grains	OVN=20ppm	NSC	B-4 8-10'	9 10 11 10	Sampled at 12:25
	10	Hole terminated as per workplan.					

ELEV. a	DEPTH b	DESCRIPTION OF MATERIALS c	FIELD SCREENING RESULTS d	GEOTECH SAMPLE OR CORE BOX NO e	ANALYTICAL SAMPLE NO f	BLOW COUNTS g	REMARKS h
	6	Sand coarsening with depth	LEL=1% O ₂ =21.8%		B-5 8'-6"	6 5 4	Sampled at 14:35
	7		OVA=7100ppm	NSC			
	8	Color change to buff-white SAND (SF)	LEL=1% O ₂ =21.8%		B-5	9 10 12 4	Sampled at 14:40
	9	Course Grained to Med. Grained fine fine gravel fine silt angular grains mod. D ₅₀ saturated	OVA=46ppm	NSC	8'-10"		
	10	Drilling terminated at 10' as per Workplan					

ELEV. a	DEPTH b	DESCRIPTION OF MATERIALS c	FIELD SCREENING RESULTS d	GEOTECH SAMPLE OR CORE BOX NO e	ANALYTICAL SAMPLE NO f	BLOW COUNTS g	REMARKS h
	5	Petroleum Staining					
	6		LEL: 0% O ₂ = 21.8%		B-6	10 14	
	7	Petroleum Staining	OVK = 60 ppm	NSC	E-5	12	Sampled at 15:40
	8	SAND (SP) Medium to coarse grained with fine to coarse hard fine granules angular grains				15 10	
	9		OVK = 40 ppm	NSC	B-6 E-10		Sampled at 15:45
	10	Logging terminated as per NSI plan.					

DATE: 10/21/92

WELL NO.: MW-4D
SITE LOCATION: PUMP HOUSE 3

SEYMOUR JOHNSON AFB
WELL LOCATION: DOWNGRADIENT OF RECOVERY TRENCH

TOP OF CASING ELEV: 101.55

RISER: 6" 0-25 ft . 2" 0-24.5ft .

SCREEN: NA . 2" 24.5-29.5 ft .

SUMP: NA

RISER TYPE: 6" PVC . 2" PVC .

SCREEN TYPE : 0.020" SLOT CONTINUOUS-WRAP PVC

CENTRALIZERS: NONE

DRILLING METHOD: HOLLOW-STEM AUGERS

DRILLING FLUID: NA

WELL DEVELOPMENT: PUMPING

WATER LEVEL: 6.49 ft TO WATER ON 11/19/92

Diagram not to scale

GEOTECHNICAL RESULTS from 27-29 ft below grade:

USCS Symbol: CL Percent finer than #4: 99.3

Water content: 29.6 Percent finer than #200: 44.6

Liquid Limit: 41.0

Plasticity Index: 25.0

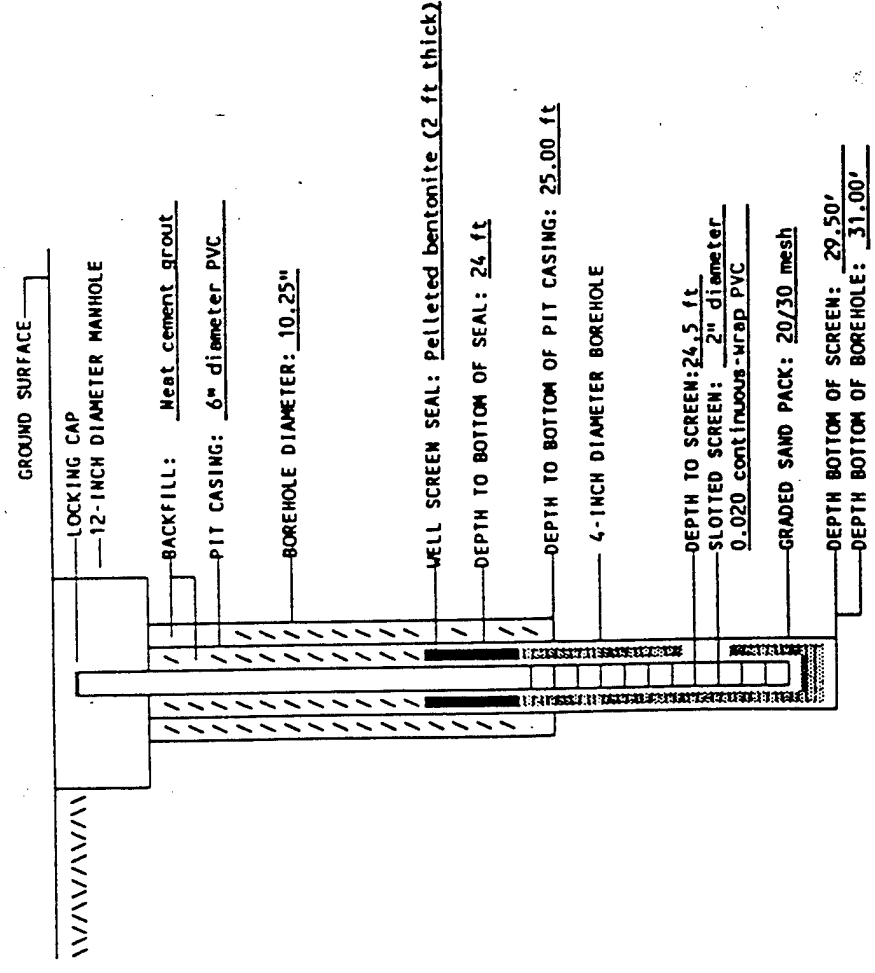

PROJECT NAME: SEYMOUR JOHNSON AFB ENG/GEO: R. DAVID ASTI DATE: 10/21/92

PROJECT NO.: 519019 CHECKED BY: KIM D. TAPPA DATE: 03/26/93

WELL CONSTRUCTION FORM

APPENDIX B

LABORATORY ANALYTICAL REPORTS

@ AIR TOXICS LTD.

AN ENVIRONMENTAL ANALYTICAL LABORATORY

WORK ORDER #: 9606272

Work Order Summary

CLIENT: Ms. Amanda Bush
Battelle Memorial Institute
505 King Avenue
Columbus, OH 43201-2693

BILL TO: Accounts Payable
Parsons Engineering Science, Inc.
1700 Broadway, Suite 900
Denver, CO 80290

PHONE: 614-424-4996
FAX: 614-424-3667
DATE RECEIVED: 6/25/96
DATE COMPLETED: 7/8/96

INVOICE # 10851
P.O. # 91221
PROJECT # G462201-30B1701 Seymour Johnson AFB
AMOUNT\$: \$302.33

<u>FRACTION #</u>	<u>NAME</u>	<u>TEST</u>	<u>RECEIPT VAC./PRES.</u>	<u>PRICE</u>
01A	SJ-Stack Gas-1	TO-3	2.0 "Hg	\$120.00
02A	SJ-Stack Gas-2	TO-3	1.0 "Hg	\$120.00
03A	Lab Blank	TO-3	NA	NC

Misc. Charges 1 Liter Summa Canister Preparation (2) @ \$15.00 each. \$30.00
Shipping (6/11/96) - \$32.33

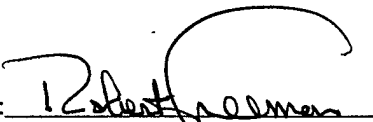
CERTIFIED BY: 
Laboratory Director

DATE: 7/8/96

180 BLUE RAVINE ROAD, SUITE B • FOLSOM, CA 95630
(916) 985-1000 • FAX (916) 985-1020

AIR TOXICS LTD.

SAMPLE NAME: SJ-Stack Gas-1

ID#: 9606272-01A

EPA METHOD TO-3

(Aromatic Volatile Organics in Air)

GC/PID

File Name: 6070120 Date of Collection: 6/17/96
Dil. Factor: 2160 Date of Analysis: 7/1/96

Compound	Det. Limit (ppmv)	Det. Limit (uG/L)	Amount (ppmv)	Amount (uG/L)
Benzene	2.2	7.0	72	230
Toluene	2.2	8.3	250	960
Ethyl Benzene	2.2	9.5	24	100
Total Xylenes	2.2	9.5	64	280

TOTAL PETROLEUM HYDROCARBONS

GC/FID

(Quantitated as Jet Fuel)

File Name: 6070120 Date of Collection: 6/17/96
Dil. Factor: 2160 Date of Analysis: 7/1/96

Compound	Det. Limit (ppmv)	Det. Limit (uG/L)	Amount (ppmv)	Amount (uG/L)
TPH* (C5+ Hydrocarbons)	22	140	48000	310000
C2 - C4** Hydrocarbons	22	40	13000	24000

*TPH referenced to Jet Fuel (MW=156)

**C2 - C4 Hydrocarbons referenced to Propane (MW=44)

Container Type: 1 Liter Summa Canister

AIR TOXICS LTD.

SAMPLE NAME: SJ-Stack Gas-2

ID#: 9606272-02A

EPA METHOD TO-3

(Aromatic Volatile Organics in Air)

GC/PID

File Name: 6070121 Date of Collection: 6/19/96
Dil. Factor: 1045 Date of Analysis: 7/1/96

Compound	Det. Limit (ppmv)	Det. Limit (uG/L)	Amount (ppmv)	Amount (uG/L)
Benzene	1.0	3.4	380	1200
Toluene	1.0	4.0	400	1500
Ethyl Benzene	1.0	4.6	38	170
Total Xylenes	1.0	4.6	110	480

TOTAL PETROLEUM HYDROCARBONS

GC/FID

(Quantitated as Jet Fuel)

File Name: 6070121 Date of Collection: 6/19/96
Dil. Factor: 1045 Date of Analysis: 7/1/96

Compound	Det. Limit (ppmv)	Det. Limit (uG/L)	Amount (ppmv)	Amount (uG/L)
TPH* (C5+ Hydrocarbons)	10	68	72000	470000
C2 - C4** Hydrocarbons	10	19	18000	33000

*TPH referenced to Jet Fuel (MW=156)

**C2 - C4 Hydrocarbons referenced to Propane (MW=44)

Container Type: 1 Liter Summa Canister

AIR TOXICS LTD.

SAMPLE NAME: Lab Blank

ID#: 9606272-03A

EPA METHOD TO-3

(Aromatic Volatile Organics in Air)

GC/PID

File Name: 6070119 Date of Collection: NA
Dil. Factor: 1.00 Date of Analysis: 7/1/96

Compound	Det. Limit (ppmv)	Det. Limit (uG/L)	Amount (ppmv)	Amount (uG/L)
Benzene	0.001	0.003	Not Detected	Not Detected
Toluene	0.001	0.004	Not Detected	Not Detected
Ethyl Benzene	0.001	0.004	Not Detected	Not Detected
Total Xylenes	0.001	0.004	Not Detected	Not Detected

TOTAL PETROLEUM HYDROCARBONS

GC/FID

(Quantitated as Jet Fuel)

File Name: 6070119 Date of Collection: NA
Dil. Factor: 1.00 Date of Analysis: 7/1/96

Compound	Det. Limit (ppmv)	Det. Limit (uG/L)	Amount (ppmv)	Amount (uG/L)
TPH* (C5+ Hydrocarbons)	0.010	0.065	Not Detected	Not Detected
C2 - C4** Hydrocarbons	0.010	0.018	Not Detected	Not Detected

*TPH referenced to Jet Fuel (MW=156)

**C2 - C4 Hydrocarbons referenced to Propane (MW=44)

Container Type: NA

AIR TOXICS LTD.
AN ENVIRONMENTAL ANALYTICAL LABORATORY

180 BLUE RAVINE ROAD, SUITE B
FOLSOM, CA 95630-4719
(916) 985-1000 FAX: (916) 985-1020

CHAIN-OF-CUSTODY RECORD

No. **007461**

Page of

Contact Person Rick Gillespie
Company Battelle
Address 505 King Avenue City Calumet State OH Zip 43201
Phone 614-424-4327 FAX 614-424-3667
Collected By: Signature [Signature]

Project info:
P.O. #
Project # 61462201-3081701
Project Name Seigneur Jubilee ATS

Turn Around Time:
 Normal
 Rush Specify

Lab I.D.	Field Sample I.D.	Date & Time	Analyses Requested	Canister Pressure / Vacuum
				Initial Final Receipt
01A	SS-Stack Gas-1	6-17-96/1415	TPH, BTEX	28.5" Hg 0.0" Hg 20/15
02A/AH	SS-Stack Gas-2	6-19-96/0925	TPH, BTEX	28.5" Hg 0.0" Hg 1.0/15
				4/25/11

Relinquished By: (Signature) [Signature] Date/Time 6/25/96 1354 Print Name Rick Gillespie
Received By: (Signature) [Signature] Date/Time 6/25/96 1010
Relinquished By: (Signature) [Signature] Date/Time 6/25/96 1010
Received By: (Signature) [Signature] Date/Time 6/25/96 1010

Notes: Seal remains to Blotch Place
C11-11201-41531
See King, H...
Coleman, 011/13201

Shipper Name FED EX Air Bill # 0656872585 Opened By: NA Date/Time 6/25/96 1010 Temp. (°C) AMBIENT Condition GOOD Custody Seals Intact? Yes No None N/A 9606272 Work Order #

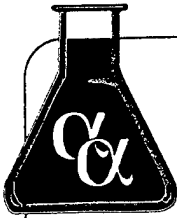

Alpha Analytical, Inc.

255 Glendale Avenue, Suite 21
Sparks, Nevada 89431
(702) 355-1044
FAX: 702-355-0406
1-800-283-1183

e-mail: alpha@powernet.net
http://www.powernet.net/~alpha

2505 Chandler Avenue, Suite 1
Las Vegas, Nevada 89120
(702) 498-3312
FAX: 702-736-7523
1-800-283-1183

ANALYTICAL REPORT

Battelle
505 King Ave
Columbus Ohio 43201

Job#: G46 2201-30B1701
Phone: (614) 424-6199
Attn:

Alpha Analytical Number: BMI061896-02

Client I.D. Number: SJ-F-1

Date Sampled: 06/17/96

Date Received: 06/18/96

Compound	Method	Concentration ug/Kg	Detection Limit ug/Kg	Date Analyzed
Benzene	8240	ND	200,000	06/25/96
Toluene	8240	580,000	200,000	06/25/96
Total Xylenes	8240	5,700,000	200,000	06/25/96
Ethylbenene	8240	720,000	200,000	06/25/96
C-range Compounds	Method	Percentage of Total	Detection Limit (Not Applicable)	Date Analyzed
<C09	GC/FID	15.14	NA	06/21/96
C10	GC/FID	15.37	NA	06/21/96
C11	GC/FID	20.84	NA	06/21/96
C12	GC/FID	22.10	NA	06/21/96
C13	GC/FID	15.78	NA	06/21/96
C14	GC/FID	7.35	NA	06/21/96
C15	GC/FID	2.03	NA	06/21/96
C16	GC/FID	0.64	NA	06/21/96
C17	GC/FID	0.23	NA	06/21/96
C18>	GC/FID	0.53	NA	06/21/96

Approved by:

Roger L. Scholl

Roger L. Scholl, Ph.D.
Laboratory Director

Date:

6/27/96

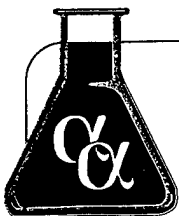

Alpha Analytical, Inc.

255 Glendale Avenue, Suite 21
Sparks, Nevada 89431
(702) 355-1044
FAX: 702-355-0406
1-800-283-1183

e-mail: alpha@powernet.net
http://www.powernet.net/~alpha

2505 Chandler Avenue, Suite 1
Las Vegas, Nevada 89120
(702) 498-3312
FAX: 702-736-7523
1-800-283-1183

ANALYTICAL REPORT

Battelle
505 King Ave
Columbus Ohio 43201

Job#: G462201-30B1701
Phone: (614) 424-6199
Attn: Al Pollock

Sampled: 06/12-14/96 Received: 06/18/96 Analyzed: 06/22-25/96

Matrix: [X] Soil [] Water [] Waste

Analysis Requested: TPH - Total Petroleum Hydrocarbons-Purgeable
Quantitated As Gasoline
BTEX - Benzene, Toluene, Ethylbenzene, Xylenes

Methodology: TPH - Modified 8015/DHS LUFT Manual/BLS-191
BTEX - Method 624/8240

Results:

Client ID/ Lab ID	Parameter	Concentration	Detection Limit
SJ-S-MPA-5.0 /BMI061896-03	TPH (Purgeable)	ND	10 mg/Kg
	Benzene	110	20 ug/Kg
	Toluene	150	20 ug/Kg
	Ethylbenzene	ND	20 ug/Kg
	Total Xylenes	120	20 ug/Kg
SJ-S-MPD-5.5 /BMI061896-04	TPH (Purgeable)	6,800	1,000 mg/Kg
	Benzene	24,000	2,000 ug/Kg
	Toluene	80,000	2,000 ug/Kg
	Ethylbenzene	15,000	2,000 ug/Kg
	Total Xylenes	93,000	2,000 ug/Kg

ND - Not Detected

Approved by:

Roger L. Scholl

Date:

6/27/96

Roger L. Scholl, Ph.D.
Laboratory Director



Sierra
Environmental
Monitoring, Inc.

June 26, 1996

TO: Alpha Analytical
FROM: Sierra Environmental Monitoring, Inc.
RE: Particle Size Distribution Analysis for Samples:
SEM 9606-0665 BMI 061896-03-SJ-S-MPA-5.0
SEM 9606-0666 BMI 061896-04-SJ-S-MPD-5.5

As per your request, we have performed particle size analysis on the samples submitted to our laboratory. Test results are as follows:

9606-0665	Clay: 6.5 %	Silt: 2.4 %	Sand: 91.1 %
9606-0666	Clay: 2.2 %	Silt: 2.3 %	Sand: 95.5 %

The samples were passed through a #10 sieve prior to analysis as per procedure. All results are based on oven dry sample weights.

We appreciate this opportunity to provide our laboratory testing services. If you have any questions or require further testing, please feel free to contact us at your convenience.

Sincerely,
SIERRA ENVIRONMENTAL MONITORING, INC.

John Seher
Laboratory Manager

1135 Financial Blvd.
Reno, NV 89502
Phone (702) 857-2400
FAX (702) 857-2404

William F. Pillsbury
President

John C. Seher
Manager

Laboratory
Analysis Report



Sierra
Environmental
Monitoring, Inc.

Date : 6/27/96
Client : ALP-855
Taken by: CLIENT
Report : 16628
PO# :

ALPHA ANALYTICAL
255 GLENDALE AVENUE, SUITE 21
SPARKS NV 89431

Page: 1

Sample	Collected		MOISTURE CONTENT %	DENSITY G/CM3	POROSITY %	PARTICLE SIZE DISTRIBUTION FRACTION %		
	Date	Time						
MI061896-03 - SJ-S-MPA-5.0	6/17/96	:	15.28	1.16	56.2	See Report		
MI061896-04 - SJ-S-MPD-5.5	6/14/96	:	14.67	1.24	53.2	See Report		

A handwritten signature in dark ink, appearing to read "John C. Seher", is written over a horizontal line.

Approved By: _____

This report is applicable only to the sample received by the laboratory. The liability of the laboratory is limited to the amount paid for this report. This report is for the exclusive use of the client to whom it is addressed and upon the condition that the client assumes all liability for the further distribution of the report or its contents.

William F. Pillsbury
President

1135 Financial Blvd.
Reno, NV 89502
Phone (702) 857-2400
FAX (702) 857-2404

John C. Seher
Manager

APPENDIX C
SYSTEM CHECKLIST

Checklist for System Shakedown

Site: Seymour Johnson AFB
6-13-96

Date: 6-13-96

Operator's Initials: RG

Equipment	Check if Okay	Comments
Liquid Ring Pump		Pinhole at base of LRP housing sealed w/ methalepoxy
Aqueous Effluent Transfer Pump	✓	
Oil/Water Separator	✓	
Vapor Flow Meter	✓	
Fuel Flow Meter	✓	
Water Flow Meter	✓	
Emergency Shut off Float Switch -Effluent Transfer Tank	✓	
Analytical Field Instrumentation -GasTeclor O ₂ /CO ₂ Analyzer -TraceTeclor Hydrocarbon Analyzer -Oil/Water Interface Probe -Magnehelic Boards -Thermocouple Thermometer	✓ ✓ ✓ ✓ ✓	

APPENDIX D

DATA SHEETS FROM THE SHORT-TERM PILOT TEST

Seymour Johnson AFB
 Baildown Test Record
 MW-1

DATE: 6-11-96	
Site: Pump house #3	
Time: 16:25	
Well Identification: MW-1, 2" I.D.	
Initial Depth to Fuel:	5.36 ft
Initial Depth to Water:	6.97 ft
Total Volume Removed:	7 L
Notes: Fuel color- light brown with green tint.	

TIME (DATE/HR:MM:SS)	ELAPSED TIME (HR:MM:SS)	DEPTH TO FUEL (FT)	DEPTH TO WATER (FT)	PRODUCT THICKNESS (FT)
6/11/96 16:40:30	0	5.72	6.13	0.41
6/11/96 16:41:00	0:00:30	5.71	6.13	0.42
6/11/96 16:42:00	0:01:30	5.70	6.13	0.43
6/11/96 16:42:30	0:02:00	5.68	6.13	0.45
6/11/96 16:44:00	0:03:30	5.66	6.11	0.45
6/11/96 16:46:30	0:06:00	5.65	6.13	0.48
6/11/96 16:48:30	0:08:00	5.65	6.13	0.48
6/11/96 16:50:30	0:10:00	5.65	6.13	0.48
6/11/96 16:55:30	0:15:00	5.65	6.14	0.49
6/11/96 17:00:00	0:19:30	5.65	6.14	0.49
6/11/96 17:10:00	0:29:30	5.65	6.15	0.50
6/11/96 17:25:00	0:44:30	5.65	6.16	0.51
6/11/96 18:04:00	1:23:30	5.65	6.18	0.53
6/11/96 18:57:00	2:16:30	5.65	6.19	0.54
6/11/96 19:05:00	2:24:30	5.65	6.20	0.55
6/11/96 19:40:00	2:59:30	5.65	6.20	0.55
6/11/96 21:24:00	4:43:30	5.67	6.22	0.55
6/11/96 22:44:00	6:03:30	5.68	6.24	0.56
6/12/96 7:40:00	14:59:30	5.68	6.25	0.57

Seymour Johnson AFB
 Baildown Test Record
 MW-2

DATE: 6-11-96
Site: Pump house #3
Time: 17:32
Well Identification: MW-2, 2" I.D.
Initial Depth to Fuel: 4.95 ft
Initial Depth to Water: 7.31 ft
Total Volume Removed: 15L
Notes: Fuel color- light brown with green tint.

TIME (DATE/HR:MM:SS)	ELAPSED TIME (HR:MM:SS)	DEPTH TO FUEL (FT)	DEPTH TO WATER (FT)	PRODUCT THICKNESS (FT)
6/11/96 17:48	0:00	5.60	6.04	0.44
6/11/96 17:49	0:01:00	5.56	6.03	0.47
6/11/96 17:49	0:01:30	5.53	6.00	0.47
6/11/96 17:50	0:02:00	5.51	6.00	0.49
6/11/96 17:50	0:02:30	5.49	5.98	0.49
6/11/96 17:51	0:03:00	5.48	5.97	0.49
6/11/96 17:51	0:03:30	5.48	5.97	0.49
6/11/96 17:52	0:04:00	5.46	5.96	0.50
6/11/96 17:52	0:04:30	5.45	5.94	0.49
6/11/96 17:53	0:05:00	5.45	5.95	0.50
6/11/96 17:54	0:06:00	5.44	5.95	0.51
6/11/96 17:55	0:07:00	5.43	5.95	0.52
6/11/96 17:56	0:08:00	5.43	5.95	0.52
6/11/96 17:58	0:10:00	5.42	5.95	0.53
6/11/96 18:00	0:12:00	5.42	5.95	0.53
6/11/96 18:02	0:14:00	5.42	5.95	0.53
6/11/96 18:07	0:19:00	5.40	5.95	0.55
6/11/96 18:12	0:24:00	5.40	5.95	0.55
6/11/96 18:22	0:34:00	5.40	5.96	0.56
6/11/96 18:35	0:47:00	5.40	6.01	0.61
6/11/96 19:00	1:12:00	5.39	6.04	0.65
6/11/96 19:35	1:47:00	5.37	6.07	0.70
6/11/96 21:22	3:34:00	5.38	6.14	0.76
6/11/96 22:42	4:54:00	5.38	6.19	0.81
6/12/96 7:38	13:50:00	5.34	6.21	0.87
6/13/96 7:15	37:27:00	5.29	6.24	0.95

Seymour Johnson AFB
 Baildown Test Record
 MW-3

DATE: 6/11/96	
Site: Pump house #3	
Time 18:51	
Well Identification: MW-3, 2" I.D.	
Initial Depth to Fuel:	5.87 ft
Initial Depth to Water:	6.38 ft
Total Volume Removed:	750 ml
Notes: Fuel color- light brown with green tint.	

TIME (DATE/HR:MM:SS)	ELAPSED TIME (HR:MM:SS)	DEPTH TO FUEL (FT)	DEPTH TO WATER (FT)	PRODUCT THICKNESS (FT)
6/11/96 19:12	0:00:00	6.07	6.35	0.28
6/11/96 19:12	0:00:30	6.07	6.36	0.29
6/11/96 19:13	0:01:00	6.06	6.36	0.3
6/11/96 19:13	0:01:30	6.05	6.36	0.31
6/11/96 19:14	0:02:30	6.06	6.37	0.31
6/11/96 19:16	0:04:00	6.05	6.37	0.32
6/11/96 19:18	0:06:00	6.04	6.38	0.34
6/11/96 19:20	0:08:00	6.04	6.38	0.34
6/11/96 19:25	0:13:00	6.04	6.39	0.35
6/11/96 19:30	0:18:00	6.04	6.39	0.35
6/11/96 19:40	0:28:00	6.03	6.4	0.37
6/11/96 21:20	2:08:00	6.03	6.43	0.4
6/11/96 22:38	3:26:00	6.03	6.43	0.4
6/12/96 7:34	12:22:00	6.01	6.42	0.41

Fuel and Water Recovery Data

Site: Seymour Johnson AFB
 Well ID: MW-2
 Test Type: Vacuum Enhancement

Start Date: 6/15/96
 End Date: 6/19/96
 Operators: R. Gillespie, M. Woolfe

Date/Time (mm/dd/yr hr:min)	Elapsed Time (hours)	LNAPL Recovery				Groundwater Recovery			
		Collected (gal)	Total (gal)	Rate (gph)	Avg. Rate (gph)	Collected (gal)	Total (gal)	Rate (gph)	Avg. Rate (gph)
6/15/96 14:45	0	0.00	0.0	0.0	0.0	0.00	0.0	0.0	0.0
6/15/96 15:45	1.0	0.00	0.0	0.0	0.0	163.00	163.0	163.0	163.0
6/15/96 16:45	2.0	0.00	0.0	0.0	0.0	163.00	326.0	163.0	163.0
6/15/96 17:45	3.0	0.00	0.0	0.0	0.0	174.00	500.0	174.0	166.7
6/15/96 19:40	4.9	0.34	0.3	0.2	0.1	244.00	744.0	127.3	151.3
6/15/96 22:40	7.9	0.00	0.3	0.0	0.1	74.00	818.0	24.7	103.3
6/16/96 7:20	16.6	0.20	0.5	0.0	0.0	75.00	893.0	8.7	53.8
6/16/96 10:00	19.2	0.00	0.5	0.0	0.0	298.00	1191.0	111.8	61.9
6/16/96 15:00	24.2	0.21	0.8	0.0	0.0	76.00	1267.0	15.2	52.2
6/16/96 23:05	32.3	0.00	0.8	0.0	0.0	805.00	2072.0	99.6	64.1
6/17/96 4:45	38.0	0.00	0.8	0.0	0.0	523.00	2595.0	92.3	68.3
6/17/96 17:10	50.4	0.34	1.1	0.0	0.0	966.00	3561.0	77.8	70.6
6/17/96 21:40	54.9	0.00	1.1	0.0	0.0	293.00	3854.0	65.1	70.2
6/18/96 6:05	63.3	0.00	1.1	0.0	0.0	638.00	4492.0	75.8	70.9
6/18/96 14:15	71.5	0.29	1.4	0.0	0.0	596.00	5088.0	73.0	71.2
6/18/96 21:45	79.0	0.00	1.4	0.0	0.0	576.00	5664.0	76.8	71.7
6/19/96 5:50	87.1	0.00	1.4	0.0	0.0	635.00	6299.0	78.6	72.3
6/19/96 10:25	91.7	0.29	1.7	0.1	0.0	287.00	6586.0	62.6	71.8
Total Time (hours)	91.67	Rate (gph)	0.02	Rate (gpd)	0.44	Rate (gph)	71.85	Rate (gpd)	1724.33

Pumping Test Data

Site: Seymour Johnson AFB
 Well ID: MW-2
 Test Type: Vacuum Enhancement

Start Date: 6/15/96
 Start Time: 14:45
 Operators: R. Gillespie, M. Woolfe

Depth to GW (ft): 6.98
 Depth to Fuel (ft): 6.83
 Depth to Tube (ft): 6.90

Date/Time (mm/dd/yr hr:min)	Run Time (hrs)	Vapor Extraction			Pump 1 Head Vacuum (in Hg)	Pump 2 Head Vacuum (in Hg)	Slurper Vacuum (in H ₂ O)	Stack/ Tank Temp. (°C)	Tank Press. (in H ₂ O)	Stack TPH (ppm)	Stack O ₂ (%)	Stack CO ₂ (%)
		Stack Press. (in H ₂ O)	Carbon Drums (in H ₂ O)	Flow Rate (scfm)								
6/15/96 14:45	0.0	0.05	--	25.00		15.0	45.0					
6/15/96 15:45	1.0	0.04	--	22.00		15.0	45.0					
6/15/96 16:45	2.0	0.09	--	33.00		16.0	0.0			820.0	21.0	0.0
6/15/96 17:45	3.0	0.09	--	33.00		15.0						
6/15/96 19:40	4.9	0.17	--	46.00		12.0	22.0					
6/15/96 22:40	7.9	0.15	--	42.00		12.0	--					
6/16/96 7:20	16.6	0.09	--	33.00		12.0	20.0					
6/16/96 10:00	19.2	0.06	--	28.00		17.0	40.0					
6/16/96 15:00	24.2		--			17.0	5.0					
6/16/96 23:05	32.3	0.09	--	33.00		17.0	26.0			180.0	21.0	0.0
6/17/96 4:45	38.0	0.04	--	22.00		17.0	23.5					
6/17/96 17:10	50.4	0.00	--			16.0	26.0	102.8		>10,000	15.0	3.0
6/17/96 21:40	54.9	0.12	--	37.00		16.0	26.0					
6/18/96 6:05	63.3	0.18	--	48.00		16.0	26.0					
6/18/96 14:15	71.5	0.12	--	37.00		16.0	26.0			120.0	21.0	0.0
6/18/96 21:45	79.0	0.13	--	38.00		16.0	26.0					
6/19/96 5:50	87.1	0.12	--	37.00		16.0	22.5					
6/19/96 10:25	91.7	0.11	--	35.00		16.0	25.0	91.6		>10,000	7.0	5.5

Comments:

- Stack gas concentrations on 6-17-96 and 6-19-96 were measured when the bleed valve on the pumphead was closed completely

Atmospheric Observations

Site: Seymour Johnson AFB

Operators: R. Gillespie, M. Woolfe

Date/Time (mm/dd/yr hr:min)	Ambient Temp.		Relative Humidity (%)	Barometric Pressure (Hg)
	(°F)	(°C)		
6/13/96 7:10	67.0	19.4	NR	29.18
6/13/96 18:52	88.0	31.1	NR	29.15
6/13/96 21:12	75.0	23.9	NR	29.23
6/14/96 6:50	70.4	21.3	NR	29.23
6/14/96 13:00	91.2	32.9	NR	29.21
6/14/96 18:34	83.5	28.6	NR	29.15
6/15/96 7:30	70.8	21.6	NR	29.21
6/15/96 14:50	87.4	30.8	NR	29.18
6/16/96 7:30	70.4	21.3	NR	29.26
6/16/96 18:57	81.6	27.6	NR	29.29
6/17/96 17:00	92.4	33.6	NR	29.32
6/17/96 21:45	76.7	24.8	NR	29.32
6/18/96 6:10	75.8	24.3	NR	29.32
6/18/96 11:15	86.8	30.4	NR	29.32
6/18/96 21:45	76.2	24.6	NR	29.26
6/19/96 5:45	72.7	22.6	NR	29.26
6/19/96 16:45	76.8	24.9	NR	29.18
6/20/96 16:55	85.0	29.4	NR	29.18
6/21/96 11:25	96.2	35.7	NR	29.18

APPENDIX E
SOIL GAS PERMEABILITY TEST RESULTS

BATTELLE DISTANCE FROM VENT WELL (ft. & tenths)	RECORD SHEET FOR AIR PERMEABILITY TEST					DATE/TIME: <u>6/15/96</u> <u>1445</u>
	10'	20'	30'	5'	SITE: <u>Sydney Johnson AFB, SS-12</u>	
TIME FROM START-UP (MIN.)	PT. CODE	PT. CODE	PT. CODE	PT. CODE	RECORDED BY: <u>P. Gillespie / M. Douda</u>	COMMENTS
	MPA PRESSURE (IN H ₂ O)	MPB PRESSURE (IN H ₂ O)	MPC PRESSURE (IN H ₂ O)	MPD PRESSURE (IN H ₂ O)		
1	.05	.005	0	.15		
2	.75	.005	0	.25		
3	.75	.005	0	.25		
4	1.0	.005	.005	.24		
5	1.5	.01	.005	.24		
6	1.75	.01	.005	.25		
7	2.0	.01	.005	.30		
8	2.0	.01	.005	.30		
9	1.75	.01	.005	.37		
10	1.75	.01	.005	.38		
12	1.50	.01	.005	.38		
14	1.50	.01	.005	.38		
16	2.0	.01	.005	.41		
18	2.0	.005	.005	.47		

BATTELLE DISTANCE FROM VENT WELL (ft. & tenths)	RECORD SHEET FOR AIR PERMEABILITY TEST			DATE/TIME: <u>6/15/96 1445</u>
	PT. CODE	PT. CODE	PT. CODE	
	10'	20'	30'	S'
TIME FROM START-UP (MIN.)	MPA	MPB	MPC	MPD
	PRESSURE (IN H ₂ O)	PRESSURE (IN H ₂ O)	PRESSURE (IN H ₂ O)	PRESSURE (IN H ₂ O)
20	2.0	.005	.005	.48
30	3.0	.01	.005	.75
40	3.0	.01	.005	1.0
50	3.5	.02	0	1.0
60	4.0	.02	0	1.0
75	4.0	.025	.005	1.0
90	4.5	.025	.01	1.0
105	5.0	.05	.015	1.3
120	5.0	.04	.015	1.5
150	5.0	.03	.005	1.5
180	-	-	-	-
210	5.0	.025	.005	1.7

SITE: Seymour Soloris AFB, SS-12

RECORDED BY: R. Gillespie, M. Wolfe

COMMENTS

Soil Gas Survey performed.

BATTELLE		RECORD SHEET FOR AIR PERMEABILITY TEST				DATE/TIME: 6/15/96 1445
DISTANCE FROM VENT WELL (ft. & tenths)	10'	PT. CODE	PT. CODE	PT. CODE	PT. CODE	SITE: Seymour Johnson AFB, SS-12
TIME FROM START-UP (MIN.)	MPE	PRESSURE (IN H ₂ O)	PRESSURE (IN H ₂ O)	PRESSURE (IN H ₂ O)	PRESSURE (IN H ₂ O)	RECORDED BY: R. Gillespie, M. Wolfe
			PT. CODE	PT. CODE	PT. CODE	
						COMMENTS
1	.63					
2	.50					
3	.50					
4	1.0					
5	1.0					
6	1.0					
7	1.0					
8	1.0					
9	1.0					
10	1.0					
12	1.5					
14	1.5					
16	1.5					
18	1.5					

BATELLE		RECORD SHEET FOR AIR PERMEABILITY TEST				DATE/TIME: 6/15/96 1445
DISTANCE FROM VENT WELL (ft. & tenths)		10'				SITE: Seymour Johnson AFB
TIME FROM START-UP (MIN.)	PT. CODE	PT. CODE	PT. CODE	PT. CODE	RECORDED BY: R. Gillespie / M. Wolfe	
	MP E				COMMENTS	
	PRESSURE (IN H ₂ O)	PRESSURE (IN H ₂ O)	PRESSURE (IN H ₂ O)	PRESSURE (IN H ₂ O)		
20	2.0					
30	1.5					
40	1.5					
50	1.5					
60	2.0					
75	3.0					
90	3.0					
105	3.0				Soil Gas Survey performed.	
120	3.5					
150	3.5					
180	—					
210	3.5					

APPENDIX F
IN SITU RESPIRATION TEST RESULTS

Oxygen Utilization Rate (1)

Date: 6/21/96 Site Name: Seymour Johnson AFB

Monitoring Point: MPA

Depth of M.P. (ft): 5

Date/Time (mm/dd/yr hr:min)	Time (hr)	Oxygen (%)	Carbon Dioxide (%)	Helium (%)
6/21/96 13:00	0.0	20.00	0.00	0.05
6/21/96 16:00	3.0	21.00	0.00	0.09
6/21/96 18:45	5.8	21.00	0.00	0.06
6/21/96 23:50	10.8	21.00	0.00	0.09
6/22/96 8:00	19.0	20.00	0.00	0.09
6/22/96 14:30	25.5	20.50	0.00	0.16
6/22/96 21:00	32.0	20.00	0.00	0.13
6/23/96 8:00	43.0	20.00	0.00	0.15
6/23/96 14:15	49.3	20.00	0.00	0.15
6/23/96 21:24	56.4	20.00	0.25	0.14
6/24/96 9:30	68.5	20.00	0.25	0.17

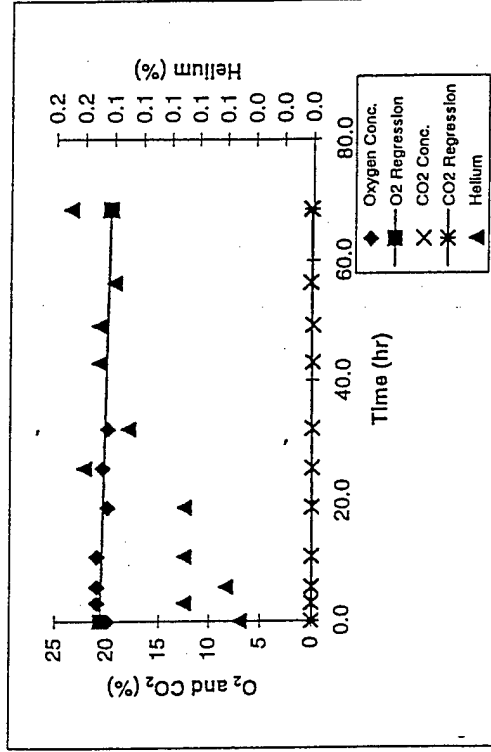

O₂ Utilization Rate

Ko 0.000 %/min
0.012 %/hr
0.298 %/day

Regression Lines	O ₂	CO ₂
Slope	-0.0124	0.0031
Intercept	20.6717	-0.0437
Determination Coef.	0.3913	0.5203
No. of Data Points.	11	11

Oxygen Utilization Rate (2)

Date: 6/21/96 Site Name: Seymour Johnson AFB
 Monitoring Point: MPB Depth of M.P. (ft): 4

Date/Time (mm/dd/yr hr:min)	Time (hr)	Oxygen (%)	Carbon Dioxide (%)	Helium (%)
6/21/96 13:00	0.0	20.00	0.00	0.40
6/21/96 16:00	3.0	20.00	0.00	0.51
6/21/96 18:45	5.8	20.00	0.00	0.31
6/21/96 23:50	10.8	20.00	0.00	0.31
6/22/96 8:00	19.0	19.00	0.00	0.34
6/22/96 14:30	25.5	19.50	0.00	0.36
6/22/96 21:00	32.0	18.00	0.50	0.37
6/23/96 8:00	43.0	16.50	0.50	0.32
6/23/96 14:15	49.3	16.00	0.75	0.20
6/23/96 21:24	56.4	16.00	0.75	0.19
6/24/96 9:30	68.5	15.50	0.75	0.17

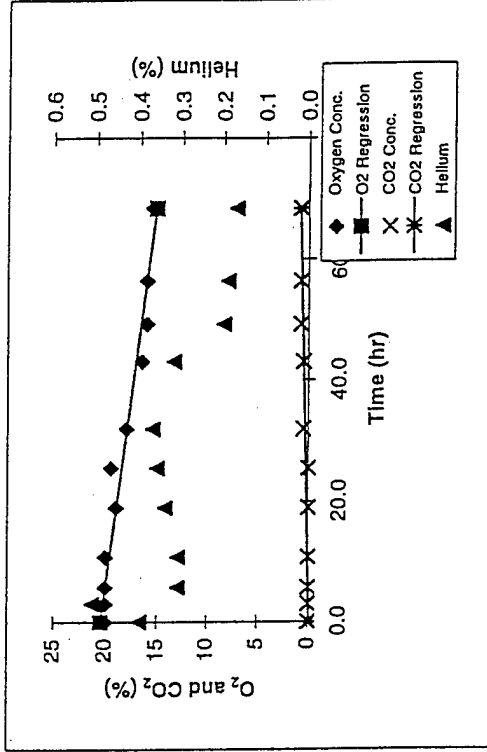

Regression Lines	O ₂	CO ₂
Slope	-0.0778	0.0139
Intercept	20.4423	-0.1013
Determination Coef.	0.9326	0.8580
No. of Data Points.	11	11

O₂ Utilization Rate

Ko 0.001 %/min
 0.078 %/hr
 1.867 %/day

Oxygen Utilization Rate (3)

Date: 6/21/96 Site Name: Seymour Johnson AFB

Monitoring Point: MPC Depth of M.P. (ft): 4

Date/Time (mm/dd/yr hr:min)	Time (hr)	Oxygen (%)	Carbon Dioxide (%)	Helium (%)
6/21/96 13:00	0.0	19.00	0.00	0.76
6/21/96 16:00	3.0	19.00	0.00	0.72
6/21/96 18:45	5.8	20.50	0.50	0.36
6/21/96 23:50	10.8	20.50	0.00	0.27
6/22/96 8:00	19.0	20.00	0.00	0.34
6/22/96 14:30	25.5	20.00	0.50	0.30
6/22/96 21:00	32.0	20.00	0.50	0.20
6/23/96 8:00	43.0	19.50	0.25	0.26
6/23/96 14:15	49.3	19.00	0.25	0.30
6/23/96 21:24	56.4	19.00	0.50	0.17
6/24/96 9:30	68.5	18.00	0.75	0.28

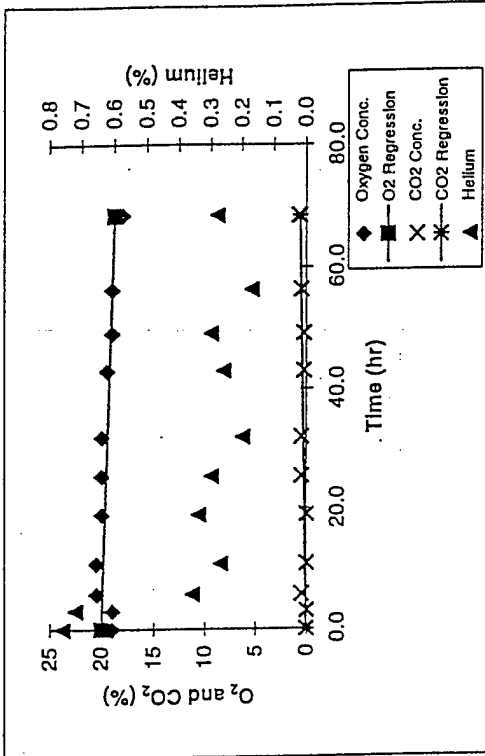

Regression Lines	O ₂	CO ₂
Slope	-0.0189	0.0077
Intercept	20.0369	0.0764
Determination Coef.	0.3213	0.4412
No. of Data Points.	11	11

O₂ Utilization Rate

Ko 0.000 %/min
0.019 %/hr
0.452 %/day

Oxygen Utilization Rate (4)

Date: 6/21/96 Site Name: Seymour Johnson AFB

Monitoring Point: MPD Depth of M.P. (ft): 5

Date/Time (mm/dd/yr hr:min)	Time (hr)	Oxygen (%)	Carbon Dioxide (%)	Helium (%)
6/21/96 13:00	0.0	21.00	0.00	0.27
6/21/96 16:00	3.0	21.00	0.00	0.40
6/21/96 18:45	5.8	21.00	0.00	0.29
6/21/96 23:50	10.8	21.00	1.00	0.17
6/22/96 8:00	19.0	20.50	0.00	0.13
6/22/96 14:30	25.5	21.00	0.00	0.27
6/22/96 21:00	32.0	20.00	0.00	0.42
6/23/96 8:00	43.0	19.50	0.25	0.39
6/23/96 14:15	49.3	19.00	0.50	0.30
6/23/96 21:24	56.4	19.00	0.50	0.41
6/24/96 9:30	68.5	18.50	0.25	0.36

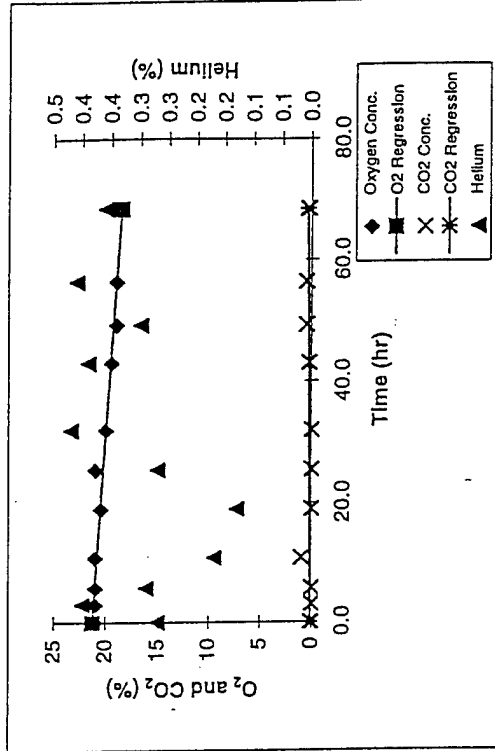

O₂ Utilization Rate

Ko: 0.001 %/min
 0.040 %/hr
 0.965 %/day

Regression Lines	O ₂	CO ₂
Slope	-0.0402	0.0038
Intercept	21.2812	0.1204
Determination Coef.	0.9183	0.0722
No. of Data Points.	11	11

Oxygen Utilization Rate (4)

Date: 6/21/96 Site Name: Seymour Johnson AFB

Monitoring Point: MPE Depth of M.P. (ft): 6

Date/Time (mm/dd/yr hr:min)	Time (hr)	Oxygen (%)	Carbon Dioxide (%)	Helium (%)
6/21/96 13:00	0.0	21.00	0.00	0.05
6/21/96 16:00	3.0	21.00	0.00	0.15
6/21/96 18:45	5.8	20.00	0.00	0.08
6/21/96 23:50	10.8	21.00	1.00	0.14
6/22/96 8:00	19.0	20.00	0.00	0.20
6/22/96 14:30	25.5	20.00	0.00	0.33
6/22/96 21:00	32.0	20.00	0.00	0.26
6/23/96 8:00	43.0	20.00	0.50	0.27
6/23/96 14:15	49.3	19.50	0.25	0.20
6/23/96 21:24	56.4	19.50	0.50	0.32
6/24/96 9:30	68.5	19.00	0.50	0.36

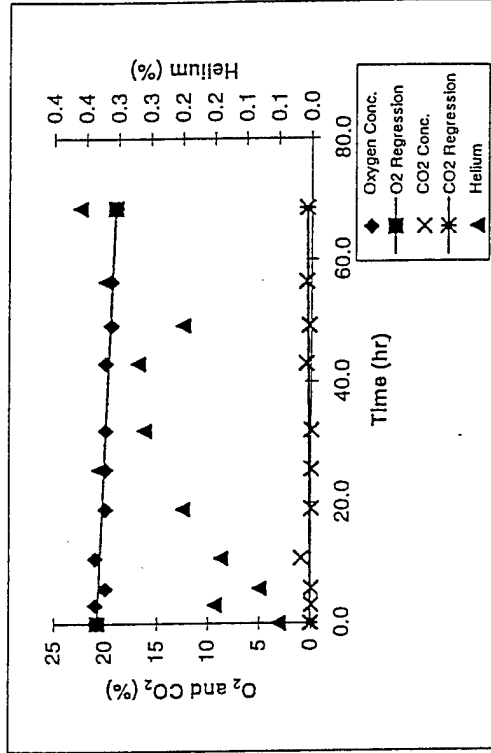

Regression Lines	O ₂	CO ₂
Slope	-0.0251	0.0053
Intercept	20.8049	0.0988
Determination Coef.	0.7732	0.1358
No. of Data Points.	11	11

O₂ Utilization Rate

Ko 0.000 %/min
0.025 %/hr
0.602 %/day