

# Formal Modeling of the Enterprise JavaBeans™ Component Integration Framework

João Pedro Sousa and David Garlan  
September 2000  
CMU-CS-00-162

School of Computer Science  
Carnegie Mellon University  
Pittsburgh, PA 15213 USA

To appear in the special issue on Component-Based Development of the *Information and Software Technology Journal*, Elsevier Print, UK. This report is an extended version of the paper "Formal Modeling of the Enterprise JavaBeans™ Component Integration Framework," which appears in the *Proceedings of FM'99, World Congress on Formal Methods in the Development of Software Systems*, Springer Verlag, LLNCS, vol. 1709, pp 1281-1300. Wing, Woodcock and Davies, editors.

**Abstract.** An emerging trend in the engineering of complex systems is the use of component integration frameworks. Such a framework prescribes an architectural design that permits flexible composition of third-party components into applications. A good example is Sun Microsystems' *Enterprise JavaBeans™ (EJB)* framework, which supports object-oriented, distributed, enterprise-level applications, such as account management systems. One problem with frameworks like EJB is that they are documented informally, making it difficult to understand precisely what is provided by the framework, and what is required to use it. We believe formal specification can help, and in this paper show how a formal architectural description language can be used to describe and provide insight into such frameworks.

This material is based upon research sponsored by the Defense Advanced Research Projects Agency (DARPA) supported by the Air Force Research Laboratory under Contract No. F30602-00-2-0616. Any opinions, findings and conclusions or recommendations expressed in this material are those of the authors and do not necessarily reflect the views of DARPA or the United States Air Force.

**DISTRIBUTION STATEMENT A**  
Approved for Public Release  
Distribution Unlimited

20001207 025

**Keywords:** Software architecture, software frameworks, component integration standards, component-based software, Enterprise JavaBeans.

## 1 Introduction

Component integration frameworks<sup>1</sup> are becoming increasingly important for commercial software systems. The purpose of a component integration framework is to prescribe a standard architectural design that permits flexible composition of third-party components. Usually a framework defines three things: (a) the overall structure of an application in terms of its major types of constituent components; (b) a set of interface standards that describe what capabilities are required of those components; and (c) reusable infrastructure that supports the integration of those components through shared services and communication channels.

A successful framework greatly simplifies the development of complex systems. By providing rules for component integration, many of the general problems of component mismatch do not arise [8]. By providing a component integration platform for third-party software, application developers can build new applications using a rich supply of existing parts. By providing a reusable infrastructure, the framework substantially reduces the amount of custom code that must be written to support communication between those parts.

A good example of a framework is Microsoft's Visual Basic<sup>TM</sup> system, which defines an architecture for component integration (Visual Basic Controls), rules for adding application-specific components (such as customized widgets, forms, graphics, etc.), and code that implements many shared services for graphical user interfaces (for example, to support coordination and communication among the parts via events.)

Another, more recent example is Sun's Enterprise JavaBeans<sup>TM</sup> (EJB) architecture. EJB is intended to support distributed, Java-based, enterprise-level applications, such as business information management systems. Among other things, it prescribes an architecture that defines a standard, vendor-neutral interface to information services including transactions, persistence, and security. It thereby permits application writers to develop component-based implementations of business processing software that are portable across different implementations of those underlying services.

One critical issue for users and implementors of a framework is the documentation that explains what the framework provides and what is required to instantiate it correctly for some application. Typically a framework is specified using a combination of informal and semi-formal documentation. On the informal side are guidelines and high-level descriptions of usage scenarios, tips, and examples. On the semi-formal side one usually finds a description of an application programmer's interface (API) that explains what kinds of services are provided by the framework. APIs are formal to the extent that they provide precise descriptions of those services – usually as a set of signatures, possibly annotated with informal pre- and post-conditions.

---

<sup>1</sup> Component integration frameworks are sometimes referred to as *component architectures*

Such documentation is clearly necessary. However, by itself it leaves many important questions unanswered – for component developers, system integrators, framework implementers, and proposers of new frameworks. For example, the framework’s API may specify the names and parameters of services provided by the infrastructure. However, it may not be clear what are the restrictions (if any) on the ordering of invocations of those services. Usage scenarios may help, but they only provide examples of selected interactions, requiring the reader to infer the general rule. Moreover, it may not be clear what facilities *must* be provided by the parts added to the framework, and which are optional.

As with most forms of informal system documentation and specification, the situation could be greatly improved if one had a precise description as a formal specification of the framework. However, a number of critical issues arise immediately. What aspects of the framework should be modeled? How should that model be structured to best expose the architectural design? How should one model the parts of the framework to maintain traceability to the original documentation, and yet still improve clarity? How should one distinguish optional from required behavior? For object-oriented frameworks what aspects of the object-oriented design should be exposed in the formal model?

In this paper we show how one can use formal architectural modeling to provide one set of answers to these questions. The key idea is to provide an abstract structural description of the framework that makes clear what are the high-level interfaces and interactions, and to characterize their semantics in terms of protocols. By making explicit the protocols inherent in the integration framework, we make precise the requirements on both the components and on the supporting infrastructure itself. This in turn yields a deeper understanding of the framework, and ultimately supports analysis of its properties. Furthermore, we can validate that the model is a useful abstraction of “reality” by checking that the model exhibits the properties that are required informally in the specification of the software framework.

In the remainder of this paper we describe our experience in developing a specification of Sun’s Enterprise JavaBeans integration framework. The primary contributions of this paper are twofold. First, we show how formal architectural models based on protocols can clarify the intent of an integration framework, as well as expose critical properties of it. Second, we describe techniques to create the model, and structure it to support traceability, tractability, and automated analysis for checking of desirable properties. These techniques, while illustrated in terms of EJB, shed light more generally on ways to provide formal architectural models of object-oriented frameworks.

## 2 Related Research

This work is closely related to three areas of prior research. The first area is the field of *architectural description and analysis*. Currently there are many architecture description languages (ADLs) and tools to support their use (such as [11], [17], [14], [13]). While these ADLs are far from being in widespread use,

there have been numerous examples of their application to realistic case studies. This paper contributes to this body of case studies, but pushes on a different dimension – namely, the application of architectural modeling to component integration frameworks.

Among existing ADLs the one used here, Wright, is most closely related to Rapide [11], since both use event patterns to describe abstract behavior of architectures. Wright differs from Rapide insofar as it supports definition of connectors as explicit semantic entities and permits static analysis using model checking tools. As we will see, this capability is at the heart of our approach for modeling integration frameworks.

The second related area is research on the *analysis of architectural standards*. An example close in spirit to our work is that of Sullivan and colleagues, who used Z to model and analyze the Microsoft COM standard [18]. In our own previous work we looked at the High Level Architecture (HLA) for Distributed Simulation [2]. HLA defines an integration standard for multi-vendor distributed simulations. We demonstrated that Wright could be used to model this framework and identify potential flaws in the HLA design. EJB differs from HLA in that it provides a different set of challenges. In particular, unlike HLA, EJB is an object-oriented framework; it has a diverse set of interface specifications; and its has weaker (but more typical) documentation.

The third related area is *protocol specification and analysis*. There has been considerable research on ways to specify protocols using a variety of formalisms, including I/O Automata [12], SMV [4, 5], SDL [10], and Petri Nets [15]. While our research shares many of the same goals, there is one important difference. Most protocol analysis assumes one is starting with a complete description of the protocol. The problem is then to analyze that protocol for various properties. In contrast, in architectural modeling of systems like EJB, protocols are typically *implicit* in the APIs described in the framework documentation. Discovering what the protocols are, and how they determine the behavior of the system is itself a major challenge.

### 3 Enterprise JavaBeans™

#### 3.1 Background

One of the most important and prevalent classes of software systems are those that support business information applications, such as accounting systems and inventory tracking systems. Today these systems are usually structured as multi-tiered client-server systems, in which business-processing software provides services to client programs, and in turn relies on lower level information management services, such as for transactions, persistence, and security (see Fig. 1.)

Currently one of the problems with writing such software is portability: application software must be partially rewritten for each vendor's support facilities because information management services provided by different vendors often have radically different interfaces.

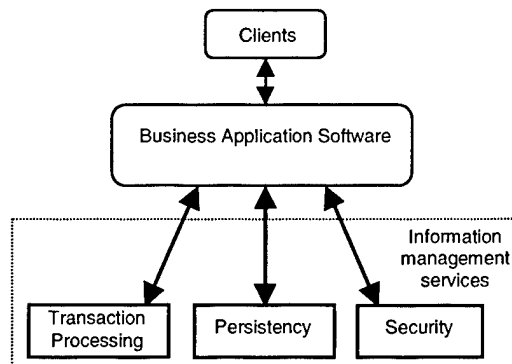

Fig. 1. A three-tiered business application

Additionally, clients of application software are faced with a huge variety of interfaces to those applications. While some differences are inevitable, given that different applications must provide different capabilities, one would wish for certain levels of standardization for generic operations such as creating or deleting business process entities (such as accounts).

To address this problem several vendors have proposed component integration frameworks for this class of system. One of these is Sun Microsystems' Enterprise JavaBeans™ framework, a component architecture for building distributed, object-oriented, multi-vendor, business applications in the Java programming language. The basic idea of the framework is to standardize on three things. First, the framework defines a standard interface to information management services, insulating application software from gratuitous differences in vendors' native interfaces. Second, the framework defines certain standard operations that can be used by client software to create, delete, and access business objects, thereby providing some uniformity across different business applications software. Third, the framework defines rules for composing object-oriented business applications using reusable components called *beans*.

By standardizing on these aspects of an information management application, EJB intends to promote application portability, multi-vendor interoperability, and rapid composition of applications from independently developed parts.

The remainder of this section elaborates on the elements of EJB that are necessary to follow the formalization in Sect. 6.

### 3.2 Overview of Enterprise JavaBeans™

Sun's "Specification of the Enterprise JavaBeans™ Architecture" [6], (henceforth, *EJB spec*) defines a standard for third parties to develop Enterprise JavaBeans™ deployment environments (henceforth, *EJB servers*). An application running in one of these environments would access information manage-

ment services by requesting them of the EJB server, via the EJB API, in the way prescribed by the EJB spec.

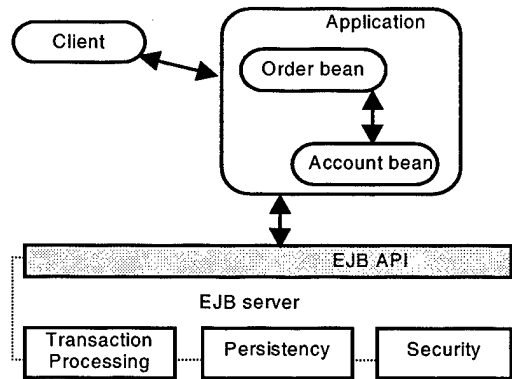

Fig. 2. The EJB server offering access to information management services.

Figure 2 illustrates a system with a remote client calling an application that implements some business logic, for which Orders and Accounts are relevant operational entities. In the object-oriented paradigm, such entities are termed *objects*. An object can be viewed as a unit that holds a cohesive piece of information and that defines a collection of operations (implemented by methods) to manipulate it.

The EJB framework defines particular kinds of objects, termed Enterprise JavaBeans™ (*beans*, for short). Beans must conform to specific rules concerning the methods to create or remove a bean, or to query a population of beans for the satisfaction of some property. Hence, whenever client software needs to access a bean, it can take some features for granted.

It is the job of EJB server *providers* to map the functionality that the EJB spec describes into available products and technologies. In version 1.0, released in March 1998, the EJB spec covers transaction management, persistence, and security services.<sup>2</sup> The EJB spec does not regulate how these services are to be implemented, however: they may be implemented by the EJB server provider, as part of the server; or they may rely on external products, eventually supplied by other vendors. Such products, however, are invisible to the beans.

A typical example of the symbiosis between an EJB server and an external product would be for an EJB server provider to offer access to one or more industry standard databases. The customer organization could then develop new applications that access existing corporate databases, using the persistency services provided by the EJB server. All that the developers of the new application would need to be aware of is the logical schema of the existing databases.

<sup>2</sup> Actually, version 1.0 views persistency services to be optional.

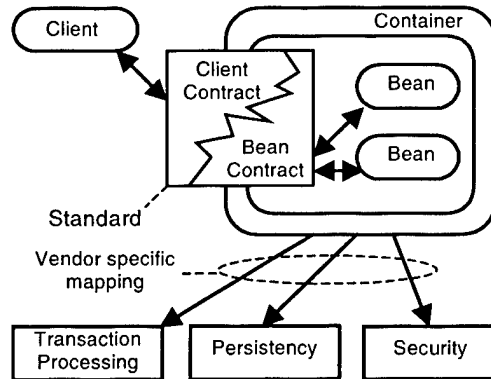

Fig. 3. The EJB container.

The EJB spec refers to the collection of services that both the beans and the client software use as a *container* (see Fig. 3). A container provides a deployment environment that wraps the beans during their lifecycle. Each bean lives within a container. The container supports (directly or indirectly) all aspects that the bean assumes about the outside world, as defined in the EJB spec.<sup>3</sup> The protocols that regulate the dialog between a bean and its container are termed the *bean contract*.

The container also supports a set of protocols, termed the *client contract*, that regulate the dialog between client software and a bean. The client contract defines two interfaces that a client uses to communicate with a specific bean: the *Home Interface* and the *Remote Interface* (see Fig. 4). Both interfaces are implemented at deployment-time by special-purpose tools supplied by the EJB server provider.<sup>4</sup> The Remote Interface reflects the functionality of the bean it represents, as it publishes the so-called business methods of the bean. Each bean has one such interface. The Home Interface contains the methods for creation and removal of beans, as well as optional methods for querying the population of beans (*finder* methods). There is one such interface per bean class.

To use the services of a bean a client first obtains a reference to the bean's class Home Interface using the Java Naming and Directory Interface<sup>TM</sup> (JNDI).

<sup>3</sup> This does not mean the container restrains beans from accessing the world outside EJB. For instance, a bean may include Java Database Connectivity (JDBC) code to access a database directly. However, in doing so, the bean sacrifices implementation independence and distribution transparency.

<sup>4</sup> In Java, the Home and Remote Interface are termed `EJBHome` and `EJBObject`, respectively. These two interfaces in the EJB spec are *extended* by user-written, domain-specific, Java interfaces. (Appendix C has details on this.) Such domain-specific Java interfaces are read by the deployment tools to produce the container-specific classes that implement the two interfaces. The latter classes are, however, invisible to the user. For the sake of clarity we will continue to refer to the user-specified interfaces as Home and Remote Interface.

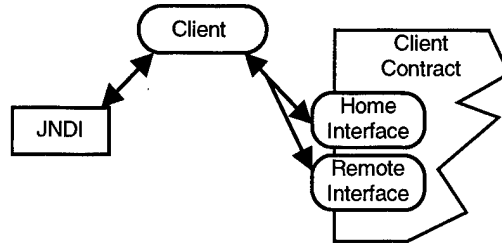

Fig. 4. Detail of the client contract.

Using this reference, the client software can call a `create` method in the class's Home Interface, thus obtaining a reference to the bean's Remote Interface implemented by the container. The Remote Interface then delegates subsequent method calls to the corresponding bean. The fact that the client uses JNDI to obtain a reference to the Home Interface of the class is a necessary condition for distribution transparency. Any piece of software, including a bean, may use the client contract to communicate with some bean if the software does not know (or care) where the target bean is actually being deployed. Such software calls the interfaces in the container holding the target bean using Java's Remote Method Invocation.

Beans are not required to include any code for managing transactions. Transaction management can be fully controlled by the container, based on a collection of deployment attributes associated to the bean (class.) Such collection of attributes is termed the *deployment descriptor* and is defined during the deployment of a bean class. Deployment descriptors include an attribute that declares transactions as being *bean managed* or *container managed*.<sup>5</sup> Since application managed transactions is a well-known problem in traditional transactional systems, in the remainder of this paper we care about container managed transactions.

Each method in a bean is characterized<sup>6</sup> in terms of transactional behavior by the deployment descriptor. When a client calls a bean, the container checks the deployment descriptor for the transactional properties of the called method. For instance, the called method may require to share the transaction context of the client (in which case the client is required to have an open transaction context before calling the bean), it may require a new context to be defined, or it

<sup>5</sup> Beans that are deployed with the "bean managed" transaction attribute can use an interface in the bean contract that supports the usual methods for explicit management of transactions: *begin*, *commit*, and so on.

<sup>6</sup> Explicitly, or implicitly by an attribute associated to the bean that applies as a default to all of its methods.

may not support a transactional behavior at all. Table 1, transcribed from page 102 in Sun's EJB spec, summarizes the effects of combining the existence, or not, of a transaction context in the client with the transactional behavior declared for the called method. Note that if a client without a transaction context calls a method with an associated `TX_MANDATORY` transaction attribute, an error will occur (`txRequiredException`, to be specific).

Transaction attribute	Client's transaction	Bean method's transaction
TX_NOT_SUPPORTED	-	-
	T1	-
TX_REQUIRED	-	T2
	T1	T1
TX_SUPPORTS	-	-
	T1	T1
TX_REQUIRES_NEW	-	T2
	T1	T2
TX_MANDATORY	-	error
	T1	T1

Table 1. Declarative transactional behavior in EJB

Notice that the transactional behavior of an application can be reconfigured without touching a line of code. By changing the values of the transactional attributes in the deployment descriptor, one may define when new transaction contexts are to be defined, and include or exclude the called methods from running under that context, or to require their own transaction context.

Transaction management in EJB is inherently distributed, since the distribution transparency provided by the client contract hides whether the called bean is deployed within the same, or another EJB server.

An EJB server manages the population of beans that reside in main memory in a way that is transparent to the client software. As the population of beans inside a container grows beyond a certain limit, determined by the EJB server, the container sends some number of the least recently used beans to secondary memory. The EJB spec refers to the beans that are subject to this operation as *passivated*. Since every call to a bean flows through the interfaces in the container, it is the container that relays the call to the bean, as appropriate. So, whenever a method call is addressed to a passivated bean, the bean is brought back to primary memory by the container. The EJB spec refers to beans that are subject to this latter operation as *activated*.

Although passivation and activation are transparent to the client calling the bean, it is not so to the bean itself. Before being passivated, the bean is required to release the shared resources it acquired previously, so as not to lock them during passivation time. Likewise, upon activation, the bean may have to reacquire

the resources to serve the client's request. Therefore, in order to allow the bean to perform these actions, the container issues synchronization messages to the bean just before passivation and immediately after activation, before the client's call is relayed (`ejbPassivate` and `ejbActivate`, in Fig. 5.)

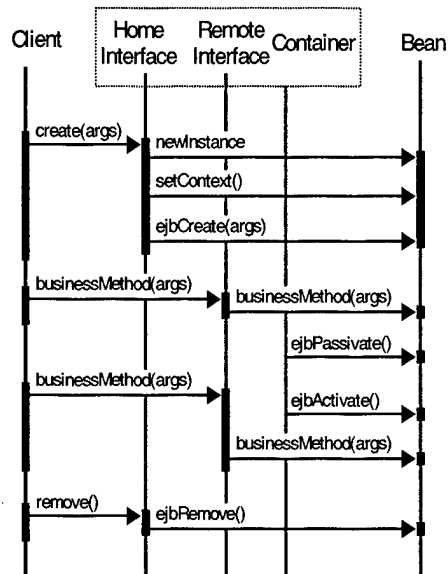

Fig. 5. Sample event trace for the lifecycle of a bean.

### 3.3 The Enterprise JavaBeans™ Specification

The EJB spec [6] released by Sun is a 180-page document, in which the concepts and their interplay are described in English, much in the same way as Sect. 3.2. A few informal state diagrams complement the explanation. There are also some chapters dedicated to the presentation of illustrative scenarios of interactions described using event trace diagrams. For instance, the event trace in Fig. 5 is an adaptation of the ones in pages 32 to 36 of the EJB spec. The document has an appendix enumerating the Java API that the elements of the architecture should follow. The signature and purpose of each method is briefly described, in English, along with an enumeration of the exceptions that may be raised. No pre- and post-conditions are provided.

Although voluminous, documentation such as this has two intrinsic problems. First, related information is spread throughout the document. For example, to determine what sequence of method calls a bean must follow to request a typical service from the container, the reader must locate the explanation in the

text (hopefully covering all relevant operations), refer to the API method descriptions, examine any examples of sample executions, and consult the list of possible raised exceptions.

Second, the lack of a precise definition makes it difficult for a reader to resolve inconsistencies and ambiguities, and to determine the intended semantics of the framework. As an example of unresolvable inconsistencies, in one place the documentation says the Home Interface should “define *zero* or more **create** methods” (page 14), while in another it says “*one* or more **create** methods” (page 20). Without a single place in the document that has the precise definition, it is impossible to determine which of the two (if either) is correct (even assuming we can determine what a **create** method should do).

As another example, consider the issue of the interaction between bean deletion and bean passivation. Suppose a client decides to remove a bean that the client has not accessed in some time. If the container has passivated that bean, it is not clear what happens. The normal rules of method invocation would imply that the bean would first have to be activated (reacquiring all resources needed for its normal operation), only to be immediately removed. This seems like a strange kind of behavior, and it is not clear if it is intended by the standard.

Finally, as with any documentation that only provides *examples* of method sequences, rather than formal *rules*, it is impossible for a reader to be sure what generalization is intended.

It seems clear that much could be gained by a formal unambiguous specification of EJB as a supplementary (or even central) resource for framework implementers, bean providers, and developers of client software. In the remainder of this paper we examine one such specification.

## 4 Wright

Wright is a formal language for describing software architecture. As with most architecture description languages, Wright describes the architecture of a system as a graph of components and connectors. Components represent the main centers of computation, while connectors represent the interactions between components. While all architecture description languages permit the specification of new component types, unlike many languages, Wright also supports the explicit specification of new architectural connector types [1].<sup>7</sup>

A simple Client-Server system description is shown in Fig. 6. This example shows three basic elements of a Wright system description: component and connector type declarations, instance declarations, and attachments. The instance declarations and attachments together define a particular system configuration.

---

<sup>7</sup> Wright also supports the ability to define architectural styles, check for consistency and completeness of architectural configurations, and check for consistent specifications of components and connectors. In this paper we restrict our presentation to just those parts of Wright that concern the specification of EJB. See [3] for further details.

In Wright, the description of a component has two important parts, the *interface* and the *computation*. A component interface consists of a number of *ports*. Each port defines a point of interaction through which the component may interact with its environment.

```

Configuration SimpleExample
  Component Server
    Port Provide = <provide protocol>
    Computation = <Server specification>
  Component Client
    Port Request = <request protocol>
    Computation = <Client specification>
  Connector C-S-connector
    Role Client = <client protocol>
    Role Server = <server protocol>
    Glue = <glue protocol>
  Instances
    s: Server
    c: Client
    cs: C-S-connector
  Attachments
    s.Provide as cs.Server;
    c.Request as cs.Client
end SimpleExample.

```

Fig. 6. A simple Client-Server system.

A connector represents an interaction among a collection of components. For example, a pipe represents a sequential flow of data between two filters. A Wright description of a connector consists of a set of *roles* and the *glue*. Each role defines the allowable behavior of one participant in the interaction. A pipe has two roles, the source of data and the recipient. The glue defines how the roles will interact with each other.

The specification of both components and connectors can be parameterized, either with a numeric range – allowing a variable number of ports or roles with identical behaviors – or with a process description – instantiating the generic structure of a component (or connector) to a specific behavior. A typical case of parameterization is a Client-Server connector that allows the attachment of a variable number of Clients, multiplexing their requests according to rules defined in the glue protocol (Fig. 7.)

Each part of a Wright description – port, role, computation, and glue – is defined using a variant of CSP [9]. Each such specification defines a pattern of events (called a process) using operators for sequencing (“→” and “;”), choice (“∇” and “□”), parallel composition (“||”) and interrup-

```

Connector C-S-connector(nClients:1..)
  Role Client1..nClients = <client protocol>
  Role Server = <server protocol>
  Glue = <client multiplexing glue protocol>

```

Fig. 7. A parameterized multi-role connector.

tion (“ $\Delta$ ”). Appendix A contains more details on the parts of CSP that we use in this paper.

Wright extends CSP in three minor syntactic ways. First, it distinguishes between *initiating* an event and *observing* an event. An event that is initiated by a process is written with an overbar. Second, it uses the symbol  $\S$  to denote the successfully-terminating process.<sup>8</sup> (In CSP this is usually written “SKIP”.) Third, Wright uses a quantification operator:  $\langle \text{op} \rangle x : S \bullet P(x)$ . This operator constructs a new process based on the process expression  $P(s)$ , and the set  $S$ , combining its parts by the operator  $\langle \text{op} \rangle$ .

For example,  $\prod_{i:1,2,3} P_i = P_1 \parallel P_2 \parallel P_3$ .

## 5 Component or Connector?

When defining the architectural structure of a framework, a key question is what are the connectors. This question is important because many frameworks are essentially concerned with providing mediating infrastructure between components that are provided by the user of the framework. Making a clear distinction between the replaceable componentry, and the mechanisms that coordinate their interaction greatly improves the comprehensibility of the framework.

From our perspective, the entities that are a locus of application-specific computation are best represented as components. The infrastructure that is prescribed by the framework to assure the interconnection between application components is a likely candidate to be represented as a (set of) connector(s).

In general, however, it may not always be obvious what should be represented as a component and what should be represented as a connector. Consider the system illustrated in Fig. 8a, consisting of three components: A, B, and C. In some cases the purpose of C is to enable the communication between A and B, using an A-C protocol over connector X, and a C-B protocol over connector Y. If those two protocols are completely independent, it makes sense to represent C as a distinct component, and keep X and Y as separate connectors.

On the other hand, if events on X are tightly coupled with those on Y (or vice versa), then it may make more sense to represent the protocol between X and Y directly using a single connector, as indicated in Fig. 8b. In this case, the connector itself encapsulates the mediating behavior of C as *glue*.

<sup>8</sup> Wright uses a non-standard interpretation of external choice in the case in which one of the branches is  $\S$ : specifically, the choice remains external, unlike, for example, the treatment in [16]. See [3] for technical details.

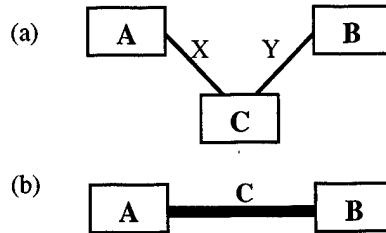

Fig. 8. Component or connector?

Representing a complex piece of software as a connector is a judgement call that is enabled by describing connectors as first class architectural entities. This perspective departs from a notion of connection that is restricted to relatively simple mechanisms like method calling, event announcing, or data pipelining. It requires the ability to describe the protocols that go on at each end of the connector (the *roles* in Wright) as well as the rules that tie those protocols together (the *glue*). In addition, it requires the ability describe complex topologies of connection, beyond simple point-to-point, like having multiple clients communicating with a server over the same set of protocols (a parametric multi-role connector in Wright – Fig. 7.)

## 6 Formalizing Enterprise JavaBeans™

Turning now to EJB (as illustrated in Fig. 3), it seems clear that clients and beans should be represented as components. Each performs significant application-specific computation, and is best viewed as a first class type of computational entity in the architectural framework. However, as the actual computations of the clients and beans cannot be defined at the framework level (since they will be determined when the framework is used to develop a particular application), we will represent those components parametrically. That is, the actual application code will be used to instantiate them at a later time.

What about the EJB container? While it would be possible to represent it as a component, as in Fig. 8a, it seems far better to consider it a rich connector, as in Fig. 8b. Not only is the container primarily responsible for bridging the gap between clients and beans, but also the container-client and container-bean sub-protocols are so tightly interwoven that it makes sense to describe them as a single semantic entity (i.e., the connector glue). For example, the effect of a remote method call from a client to a bean is mediated by the container so that if the target bean is passivated it can be activated using the container-bean activation protocol. The resulting general structure is illustrated in Fig. 9.

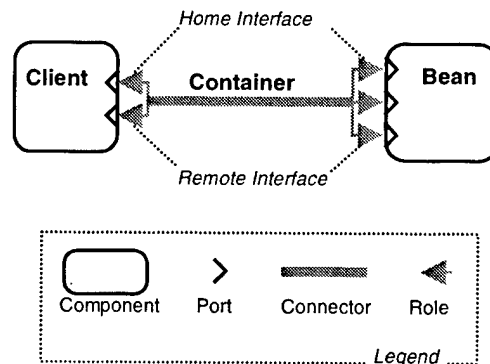

Fig. 9. One Client connected to one Bean.

In this case the Remote and Home interfaces become roles in the Container connector that both a Client and a Bean interact with. In Wright this same structure is described as shown schematically in Fig. 10.

As indicated earlier, we use a placeholder process `BusinessLogic` as a parameter to clients, beans, and the Container connector. (The connector is parameterized by the business logic because it also needs to know about the `BusinessLogic` protocol.)

The Wright specification of the configuration in Fig. 10 also defines the attachments between the ports of each component and the corresponding roles in the Container. The next sections examine each part in turn.

## 6.1 The Client

The specification of a Client component is shown in Fig. 11. It has two ports for accessing the Bean: `UseHomeInterface` and `UseRemoteInterface`. As noted above, the latter is defined by a process that describes the application logic implemented by the Bean and is passed to the Client as a parameter (`BusinessLogic`).

The process describing the client's view of the Home Interface consists of three events: `create` and `remove`, with the obvious meaning, and `getEJBMetaData`, which is a service provided by the container that returns meta-information about the methods supported by the bean. Note that the port is initialized by a `create` event and terminated by a `remove` event. The auxiliary process definition `GoHomeInterface`, describes the Home Interface perspective of what may go on between the creation of a bean and its removal: getting the bean's meta-data.

An event that may occur at any time after the creation, `noSuchObjectException`, corresponds to an exception being raised by the container. In fact, the EJB spec says that "a Client must always be prepared to recreate a new instance (of a bean) if it loses the one it is using" (pp. 24).<sup>9</sup> Hence, if the Client

<sup>9</sup> In a distributed computing environment, it is possible to lose communication with a remote server. The distribution transparency provided by EJB, however, has the

```

Configuration one-Client-one-Bean
  Component Client (BusinessLogic: Process)
    Port UseHomeInterface = <...>
    Port UseRemoteInterface = BusinessLogic
    Computation = <...>
  Component EJBan (BusinessLogic: Process)
    Port BeanHome = <...>
    Port JxBean = <...>
    Port RemoteInterface = BusinessLogic
    Computation = <...>
  Connector Container (BusinessLogic: Process)
    Role HomeInterface = <...>
    Role RemoteInterface = BusinessLogic
    Role UseBeanHome = <...>
    Role UseJxBean = <...>
    Role UseRemoteInterface = BusinessLogic
    Glue = <...>
  Process SomeBusinessLogic = <...>
  Instances
    A: Client(SomeBusinessLogic)
    B: EJBan(SomeBusinessLogic)
    C: Container(SomeBusinessLogic)
  Attachments
    A.UseHomeInterface as C.HomeInterface
    A.UseRemoteInterface as C.RemoteInterface
    C.UseBeanHome as B.BeanHome
    C.UseRemoteInterface as B.RemoteInterface
    C.UseJxBean as B.JxBean
end one-Client-one-Bean.

```

Fig. 10. The simple one-Client-one-Bean configuration.

```

Component Client (BusinessLogic: Process)
  Port UseRemoteInterface = BusinessLogic
  Port UseHomeInterface
    = create → ( GoHomeInterface
      Δ noSuchObjectException
        → UseHomeInterface )
    Δ remove → ( $ [] removeException → $ )
  Where GoHomeInterface
    = getEJBMetaData → GoHomeInterface
  Computation = create → CallBean
  Where CallBean
    = ( (UseRemoteInterface || GoHomeInterface)
      Δ noSuchObjectException → create → CallBean )
      Δ remove → ( $ [] removeException → $ )

```

Fig. 11. The Client component.

gets a `noSuchObjectException`, it should go back to create another bean. The Wright specification exhibits this property in both the specification of the process `GoHomeInterface` and in the process `CallBean` in the Client's computation: the occurrence of a `noSuchObjectException` event causes the Client to reinitialize the Home Interface by issuing a `create` event. In Sect. 7 we see how less trivial properties can be checked by the use of automated tools.

The main body of computation, once it is initialized by a `create`, is the parallel composition of the processes `UseRemoteInterface` and `GoHomeInterface`. What goes on in this composition is dictated by the application logic, passed as a parameter to the client, in parallel with the initialized Home Interface. Finally, at any time (after initialization) the client may decide to remove the bean. This is signaled by the client-initiated `remove` event interrupting the process described above (using the  $\Delta$  operator). However, the Client must be prepared to handle a `removeException`, thrown by the Container. After a `remove`, either the computation successfully terminates, or it accepts a `removeException`, after which it also terminates. The EJB spec does not define how components should handle exceptions. So we only note the fact that an exception may be received. It should be clear now that the specification of the `UseHomeInterface` port is actually a view of the Client's computation, restricted to the events recognized by the Home Interface.

The `HomeInterface` role in the container expresses the possible behaviors of the client that attaches to this role. The process specification for this role is equivalent to the process in the `UseHomeInterface` of the Client component, in the sense that it will generate the same set of traces. As shown in Fig. 12, after being initialized by `create`, the attached component will choose (internally) whether or not to `remove` the bean. If the component chooses not to remove the bean, it may initiate a request for meta-data. It also admits a `noSuchObjectException`, which resets the role. If the component chooses to remove the bean, it admits a `removeException`, but terminates afterwards, in either case.<sup>10</sup>

```

Connector Container (BusinessLogic: Process)
  Role HomeInterface =  $\overline{\text{create}}$   $\rightarrow$  GoHomeInterface
  Where GoHomeInterface
    = (  $\overline{\text{getEJBMetaData}}$   $\rightarrow$  GoHomeInterface
         $\square$   $\overline{\text{noSuchObjectException}}$   $\rightarrow$  HomeInterface )
         $\square$   $\overline{\text{remove}}$   $\rightarrow$  (  $\S$   $\square$   $\overline{\text{removeException}}$   $\rightarrow$   $\S$  )

```

**Fig. 12.** The `HomeInterface` role in the container.

---

potential to hide from the client whether the reinitialized home interface is directed to the same, recovered, server or to another that supports the same bean class.

<sup>10</sup> Again, for simplicity, we focus on a single run of the protocols between the client and the container, in order to distinguish between a situation where the protocol demands a reset, from a situation where it runs through successfully and could go back to create another bean.

## 6.2 The Container and the Bean

In the container, there are three Wright roles that are involved in the creation of a bean. The first is the `HomeInterface` role, in Fig. 12, to which the client attaches. The other two are the `UseBeanHome` and `UseJxBean` roles, in Fig. 13, to which the bean attaches.

```

Connector Container (BusinessLogic: Process)
  alpha Created =  $\alpha$ UseJxBean \ {setContext, ejbRemove}
  ...
  Role UseBeanHome = newInstance  $\rightarrow$  ejbCreate  $\rightarrow$  §
  Role UseJxBean   = setContext  $\rightarrow$  GoJxBean
  Where GoJxBean
    = ejbPassivate  $\rightarrow$  ejbActivate  $\rightarrow$  GoJxBean
    [] ejbRemove  $\rightarrow$  UseJxBean
  Glue = ...
  Where BeanLive
    = create  $\rightarrow$  newInstance  $\rightarrow$  setContext  $\rightarrow$  ejbCreate
     $\rightarrow$  ( RUNCreated
         $\Delta$  remove  $\rightarrow$  ejbRemove  $\rightarrow$  § )
  ...
Component EJBBean (EJBObject: Process)
  Port BeanHome = newInstance  $\rightarrow$  ejbCreate  $\rightarrow$  §
  Port JxBean   = setContext  $\rightarrow$  GoJxBean
  Where GoJxBean
    = ejbPassivate  $\rightarrow$  ejbActivate  $\rightarrow$  GoJxBean
    [] ejbRemove  $\rightarrow$  §

```

Fig. 13. The lifecycle of a bean.

Since it is often the case that a protocol refers to events in more than one role, the perspective that a specific role has of a protocol is limited by the alphabet of the role. It is the *glue* that links what goes on in each role, thus completing the protocol followed by the connector.

In order to single out each piece of the glue that corresponds to a particular protocol in the software framework, we introduce auxiliary process definitions. `BeanLive` in Fig. 13 is one of them. Since this is a glue process, it takes the viewpoint of the container: hence, the `create` event is initiated by the environment (in the `HomeInterface` role). After receiving a `create`, the container initiates the `newInstance` event in the `UseBeanHome` role, sets the newly created bean's run-time context (`setContext` in the `UseJxBean` role,) and signals the new bean to run the appropriate initialization method (`ejbCreate` in `UseBeanHome`).

The `BeanLive` process then accepts any event in the alphabet of the `UseJxBean` role, except for `setContext` (part of the initialization) and `ejbRemove` (part of the termination). When interrupted by a `remove` event in the `HomeInterface` role, the `BeanLive` process signals the bean to run the appropriate termination

method (`ejbRemove` in the `UseJxBean` role) and then terminates.<sup>11</sup>

The Container relays the business logic events in the role `RemoteInterface` (to which the Client attaches) to the role `UseRemoteInterface` (to which the Bean attaches). The glue process `Delegate` assures this by simply stating that any event  $e$  in the `RemoteInterface` role is followed by the (container-initiated) same event  $\bar{e}$  in the `UseRemoteInterface` role.

Recall now that the container may decide to passivate a bean according to a least recently used policy. The glue process `SwapBean` in Fig. 14 accepts any event in the alphabet of the Container,<sup>12</sup> except for the events `ejbPassivate` and `ejbActivate`. Whenever the container decides to initiate an `ejbPassivate` event, the `SwapBean` process waits for the next event in the `RemoteInterface` role. After that, and before the event is relayed to the `UseRemoteInterface` role, an `ejbActivate` event is interleaved. The parallel combination of the processes `SwapBean` and `Delegate` in the glue produces the desired effect: the business logic events are normally relayed, but whenever the bean was passivated, it receives an activation event just before the business logic event is sent.

```

Connector Container (BusinessLogic: Process)
  alpha Activated =  $\alpha$ Container \ {ejbPassivate, ejbActivate}
  Role UseJxBean = setContext  $\rightarrow$  GoJxBean
  Where GoJxBean
    = ejbPassivate  $\rightarrow$  ejbActivate  $\rightarrow$  GoJxBean
      [] ejbRemove  $\rightarrow$  UseJxBean
  ...
  Role RemoteInterface = BusinessLogic
  Role UseRemoteInterface = BusinessLogic
  Glue = BeanLive
        || Delegate
        || SwapBean
  Where Delegate = [] e:  $\alpha$ RemoteInterface •
    RemoteInterface.e  $\rightarrow$  UseRemoteInterface. $\bar{e}$   $\rightarrow$  Delegate
  Where SwapBean
    = RUNActivated  $\Delta$  ejbPassivate
     $\rightarrow$  ( [] e:  $\alpha$ RemoteInterface • RemoteInterface.e
       $\rightarrow$  ejbActivate  $\rightarrow$  UseRemoteInterface. $\bar{e}$   $\rightarrow$  SwapBean )

```

Fig. 14. The interplay between delegation and passivation.

<sup>11</sup> Note that the roles take the viewpoint of the environment (of the components that attach to the roles,) as opposed to the viewpoint of the container. So, the parity of initiation is reversed in the glue and in the roles. Note also that the processes in the roles `UseBeanHome` and `UseJxBean` match the processes in the corresponding ports in the `Bean` component, `BeanHome` and `JxBean`.

<sup>12</sup> Taken here as the union of the alphabets in all roles.

### 6.3 Transaction Management in EJB

We now extend the Wright specification to cover transaction management (refer to Appendix B for the full specification.) The first, obvious, extension is to make the client transaction-aware. Now the port `UseRemoteInterface` in Fig. 15 chooses internally whether or not to associate a transaction context to each event in the `BusinessLogic` process. By the argument made in Sect. 3.2 we will abstract how the client starts a transaction: we will be focusing on the impact that transaction management has on EJB, specifically on the container. Therefore, we treat obtaining a transaction context, `txContext`, as an internal choice of the value of the output parameter associated to an event in the business logic.

As seen in Tab.1, the client must be prepared for exceptions that follow from a mismatch between the transactional attribute associated to the called method and the fact that a client has chosen to call the method with, or without a transaction context. This is reflected in the port `UseRemoteInterface` by the existence of the interrupting event `txRequiredException` issued by the container.<sup>13</sup> Naturally, the port `UseRemoteInterface` in the container, to which the client attaches, reflects issuing this exception as appropriate: the container's computation will clarify exactly in which circumstances that happens, as we will see below.

```

Component Client (BusinessLogic: Process)
  Port UseRemoteInterface
    = ( (∏ e:αBusinessLogic • ē → UseRemoteInterface )
        ∏ (∏ e:αBusinessLogic • (∏ txContext • e!txContext
                               → UseRemoteInterface)) )
    Δ txRequiredException → UseRemoteInterface
  ...
Connector Container (BusinessLogic: Process)
  ...
  Role RemoteInterface = BusinessLogic || TransactionException
  Where TransactionException
    = txRequiredException → TransactionException
  Role UseRemoteInterface = BusinessLogic
  ...

```

Fig. 15. The transaction-aware client.

The second, also obvious extension, is to provide beans with a deployment descriptor. Figure 16 shows a new port in the bean component, `DeploymentDescriptor`, supporting a query for the transactional attribute associated to an event `e`, `queryDeploymentDescriptor?e`. After receiving one such request,

<sup>13</sup> How the client should actually handle the exception is omitted in Sun's specification, and is abstracted away here too.

the deployment descriptor will internally choose which value of the transactional attribute to output in the self initiated `getTxAttribute!txAttribute`. The deployment descriptor for a bean is available for query throughout the life of the bean, after initialization, as reflected in the definition of the bean's computation. The container now includes a role, `UseDeploymentDescriptor`, that will attach to the port `DeploymentDescriptor` on the bean, and that reflects the behavior for the latter.

```

Component EJBBean (BusinessLogic: Process)
...
Port DeploymentDescriptor = queryDeploymentDescriptor?e
    → ( ⊐ txAttribute:{TxNotSupported, TxRequired, TxSupports,
        TxRequiresNew, TxMandatory} •
        getTxAttribute!txAttribute → DeploymentDescriptor )
Computation = Init;((BeanRemote || SwapBean || DeploymentDescriptor )
...
Connector Container (BusinessLogic: Process)
...
Role UseDeploymentDescriptor = queryDeploymentDescriptor?e
    → ( ⊐ txAttribute:{TxNotSupported, TxRequired, TxSupports,
        TxRequiresNew, TxMandatory} •
        getTxAttribute!txAttribute → UseDeploymentDescriptor )
...

```

Fig. 16. The deployment descriptor associated to a bean.

The third extension is to provide the container with an interface to some Transaction Processing Monitor. Such interface, represented in Fig. 17 as the port `UseTPMonitor`, supports services to suspend and resume a given transaction context, in addition to the usual services for starting and committing transactions. In fact, the EJB spec requires non-nested transaction management: when a client holding a transaction context T1 calls a method in a bean that requires a new context, T2, context T1 is suspended while the method executes within context T2. Context T1 is resumed as soon as context T2 is terminated (either by a commit or a rollback.<sup>14</sup>)

The role `UseTPMonitor` in the container describes either a simple non-nested transaction (as described in the process `NonNestedTransaction` or a suspension of a given transaction context, followed by the full execution of a non-nested transaction, followed by the resumption of the previously suspended context. In the process `NonNestedTransaction`, we see that the TP monitor responds to a `benginTX` event with a self initiated `getTx!txContext` event, where the value of

<sup>14</sup> When the deployment attribute associated to the method requires a new (independent) transaction context, there is no dependence between the success of the transaction in the client and the one in the bean.

```

Connector Container (BusinessLogic: Process)
...
Role UseTPMonitor
= NonNestedTransaction; UseTPMonitor
  [] suspendTx?txContext → ( § [] NonNestedTransaction );
                                resumeTx?txContext → UseTPMonitor
Where NonNestedTransaction
= beginTx → ( [] txContext • getTx!txContext
              → endTx?txContext → § )
...

```

Fig. 17. The container using the services of an external TP monitor.

the txContext parameter is internally chosen by the TP monitor. This very same value is later used by the container to terminate the corresponding transaction context with the event endTx?txContext.

The most interesting extensions occur in the glue process of the container. The description of the glue itself remains the parallel composition of the processes BeanLive, SwapBean and Delegate. Whereas BeanLive remains unchanged, the SwapBean process now accommodates a transaction context for events in the business logic. Since the variants of transactional behavior are irrelevant for bean swapping, in essence, the process SwapBean remains the same (see Fig. 18.)

```

Connector Container (BusinessLogic: Process)
...
Glue = <...>
Where SwapBean
= RUNActivated Δ ejbPassivate
  → ( [] e: αRemoteInterface • RemoteInterface.e?txContext
      → ejbActivate → UseRemoteInterface.e → SwapBean )
Where Delegate
= [] e: αRemoteInterface •
  ( RemoteInterface.e?txContext
    → EnforceTxContext(e,txContext)
    [] RemoteInterface.e → CheckTxRequired(e)
  ); Delegate
...

```

Fig. 18. Swapping and delegation in the presence of transactions.

The Delegate process now distinguishes the situation where the event in the remote interface carries a transactional context, in which case the container tries to enforce that context, from the situation where the called event does not carry

a context. In the latter case the container checks if one is required. The processes **EnforceTxContext** and **CheckTxRequired** account for these two situations, and describe the rules represented in the even and odd rows of Tab. 1, respectively.

The process **EnforceTxContext** takes as parameters the called event in the remote interface, along with the transaction context passed by the client. First, it queries the deployment descriptor associated to the bean in order to obtain the value of the transactional attribute for the called event (as a parameter of the deployment descriptor-initiated event `getTxAttribute`.) Then, according to the value of the transactional attribute, it manages the transactional contexts according to the rules in Tab. 1, delegating the called event to the bean, in the appropriate context. For instance, if the transactional attribute for the event has the value **TxRequiresNew**, the container first suspends the transaction context of the client, then starts a new transaction (obtaining the new context from the TP monitor,) and finally delegates the event to the bean in this new context. Once the corresponding method is executed by the bean, the container stops the new transaction context and resumes the one originally passed by the client.

The process **CheckTxRequired** takes only the called event as parameter, since there is no transaction context passed by the client. It then follows the same procedure as **EnforceTxContext** to obtain the value of the relevant transactional attribute and manage the transaction contexts according to the rules in Tab. 1.

Once again, note the variety of transactional behavior combinations that can be achieved by declaring a transactional attribute for each method, within the deployment descriptor associated to a bean, and letting the container manage transaction contexts according to the rules in the EJB spec. Note also that by changing the values declared for each transactional attribute, the transactional behavior of a business application can be reconfigured without changing one line of code.

## 7 Using the Model

By precisely specifying the implied protocols of interaction for EJB, one achieves a number of immediate benefits. First, the formal specification is explicit about permitted orderings of method calls, and about where the locus of choice lies. Second, the specification makes explicit where different parts of the framework share assumptions. In particular, the role of **BusinessLogic** as a parameter helps clarify the way in which assumptions about the application-specific behavior are shared among the parts of the framework. Third, the model helps clarify some of the more complex aspects of the model by localizing behavior. For example, the murky role of passivation becomes clear in the Container glue.

Furthermore, it is also possible to submit the model to formal analysis via model checking tools. To do this we used the **FDR<sup>TM</sup>** model checker for CSP [7] to check for deadlocks in the container.<sup>15</sup> In addition to checking for deadlocks,

---

<sup>15</sup> Translation from Wright to FDR is accomplished semi-automatically using the Wright tool set. See [1].

```

Connector Container (BusinessLogic: Process)
...
Glue = <...>
  Where EnforceTxContext(e:  $\alpha$ RemoteInterface, txContext)
    = queryDeploymentDescriptor!e
    → ( ( getTxAttribute?TxNotSupported
          → suspendTx!txContext
          → UseRemoteInterface.e
          → resumeTx!txContext → § )
        [] ( getTxAttribute?TxSupports
             → UseRemoteInterface.e → § )
        [] ( getTxAttribute?TxRequired
             → UseRemoteInterface.e → § )
        [] ( getTxAttribute?TxMandatory
             → UseRemoteInterface.e → § )
        [] ( getTxAttribute?TxRequiresNew
             → suspendTx!txContext → beginTx → getTx?newTxContext
             → UseRemoteInterface.e
             → endTx!newTxContext → resumeTx!txContext → § ) )
  Where CheckTxRequired(e:  $\alpha$ RemoteInterface)
    = queryDeploymentDescriptor!e
    → ( ( getTxAttribute?TxNotSupported
          → UseRemoteInterface.e → § )
        [] ( getTxAttribute?TxSupports
             → UseRemoteInterface.e → § )
        [] ( getTxAttribute?TxRequired
             → beginTx → getTx?newTxContext
             → UseRemoteInterface.e
             → endTx!newTxContext → § )
        [] ( getTxAttribute?TxMandatory
             → txRequiredException → § )
        [] ( getTxAttribute?TxRequiresNew
             → beginTx → getTx?newTxContext
             → UseRemoteInterface.e
             → endTx!newTxContext → § ) )

```

Fig. 19. Container enforcing the transactional behavior variants.

FDR can also be used to make sure that specific required behaviors<sup>16</sup> still hold in the overall result of the composition of all local specifications. For that we use the CSP notion of process refinement (see Appendix A). Specifically, we can check if a process describing the desired behavior is *refined* by the overall specification; for instance, if a process describing the client's recovery after a container failure is refined by the one-Client-one-Server specification. If that is the case, that means that the intended behavior was not lost due to a mistake during the process of specifying all the interacting behaviors.

For the current model, analysis revealed one significant problem. The problem concerns a possible race condition between the delegation and passivation processes inside the Container. Suppose that the Client initiates an event in the `RemoteInterface` role. Then, before the `Delegate` process relays the event to the bean through the `UseRemoteInterface` role, the `SwapBean` process, operating concurrently, decides to passivate the bean. Now, the `Delegate` process must relay the received business logic event to the `UseRemoteInterface` role, before it can accept the next event in the `RemoteInterface` role. However, the `SwapBean` process just issued an `ejbPassivate` notification to the bean, and hence it waits for the next event in the `RemoteInterface` role to reactivate the bean. Therefore, the processes that go on inside the Container cannot agree on what to do next, and the connector deadlocks.

Figure 20 presents a simple correction for the deadlock. The `Delegate` process must prevent passivation between receiving an event in the `RemoteInterface` role and relaying it to the `UseRemoteInterface` role. One way to model it in CSP is to explicitly allow the `ejbPassivate` event outside the mentioned "critical section".

```

Connector Container (EJBObject: Process)
...
Where Delegate
  = ( [ e: αRemoteInterface •
      ( RemoteInterface.e?txContext
        → EnforceTxContext(e,txContext)
        [ RemoteInterface.e → CheckTxRequired(e)
        ); Delegate
      ) [ ejbPassivate → Delegate
  ...

```

Fig. 20. Deadlock-free delegation.

While arguably one might attribute the detected problem to *our* specification, and not to Sun's EJB spec, it does point out a place where the complexity of the

<sup>16</sup> For instance, Sun's document (pp. 24) states that any implementation of the EJB protocol between a client and an EJB server must allow the client to recover from EJB server crashes.

specification can lead to errors that might be hard to detect otherwise. Without a precise model and effective automated analysis tools to identify problem areas, such errors could easily be introduced, undetected, into an implementation.

## 8 Conclusions and Future Work

In this paper we have outlined a formal architectural model of part of Sun's EJB component integration framework. In doing this we have attempted to shed light both on EJB itself, and on the way in which one can go about modeling object-oriented architectural frameworks. The key idea in our approach is to take an architectural view of the problem that makes explicit the protocols of interaction between the principle parts of the framework. In particular, we have shown how representing the framework's mediating infrastructure as a connector with a well-defined protocol helps to clarify the overall structure of the framework and to localize the relationships between the various method calls that connect the parts.

The use of formal architectural modeling languages to represent frameworks such as EJB opens up a number of important questions to investigate. First, while our specification focused on certain properties of the framework, there are many others that one might want to model. For example, although potential deadlocks are highlighted by our model, we do not handle important issues such as performance, reliability, and security. For many frameworks finding notations that expose such properties will be crucial.

Second, given a formal specification, such as the one we have presented, it should be possible to influence conformance testing. Currently, conformance to a framework can only be loosely checked – for example, by making sure that an implementation provides the full API. However, given a richer semantic model, it should be possible to do much better.

Third, the EJB spec uses inheritance to organize the presentation of many of its concepts. For example, the `SessionBean` class inherits behavior from the `EnterpriseBean` class, which in turn inherits from the `java.io.Serializable` class. In contrast, the formal model that we have presented is essentially flat. To come up with our model we had to fold together the implicit semantic behavior defined in several classes. It would have been much nicer to have been able to mirror the inheritance structure in the architectural specification. While such extension is relatively well-understood with respect to signatures, it is not so clear what is needed to handle interactive behaviors – such as protocols of interaction. Finding a suitable calculus of protocol extension is an open and relevant topic for future research.

## References

1. Robert Allen and David Garlan. A formal basis for architectural connection. In *ACM Trans. on Software Engineering and Methodology*, July 1997.

2. Robert Allen, David Garlan, and James Ivers. Formal modeling and analysis of the HLA component integration standard. In *Sixth Intl. Symposium on the Foundations of Software Engineering (FSE-6)*, Nov. 1998.
3. Robert Allen. A Formal Approach to Software Architecture. PhD thesis, CMU, School of Computer Science, January 1997. CMU/SCS Report CMU-CS-97-144.
4. Edmund Clarke et al. Automatic verification of finite state concurrent systems using temporal logic specifications. In *ACM Trans. on Programming Languages and Systems*, April 1986.
5. Edmund Clarke et al. Verification Tools for Finite-State Concurrent Systems. A Decade of concurrency - Reflections and Perspectives. *Springer Verlag LNCS 803*, 1994.
6. Vlada Matena, Mark Hapner, Enterprise JavaBeans™, Sun Microsystems Inc., Palo Alto, California, 1998.
7. Failures Divergence Refinement: User Manual and Tutorial, 1.2β. Formal Systems (Europe) Ltd., Oxford, England, 1992.
8. David Garlan, Robert Allen, and John Ockerbloom. Architectural mismatch: Why reuse is so hard. *IEEE Software*, November 1995.
9. C. A. R. Hoare. *Communicating Sequential Processes*. Prentice Hall, 1985.
10. Gerald J. Holzmann. *Design and Validation of Computer Protocols*. Prentice Hall, 1991.
11. David C Luckham, et al. Specification and analysis of system architecture using Rapide. In *IEEE Trans. on Software Engineering*, April 1995.
12. Nancy A. Lynch and Mark R. Tuttle. An introduction to input/output automata. Technical Report MIT/LCS/TM-373, MIT LCS, 1988.
13. J. Magee, N. Dulay, S. Eisenbach, and J. Kramer. Specifying distributed software architectures. In *Proceedings ESEC'95*, Sept. 1995.
14. M. Moriconi, X. Qian, and R. Riemenschneider. Correct architecture refinement. In *IEEE Trans. on Software Engineering*, April 1995.
15. J.L. Peterson. *Petri nets*. ACM Computing Surveys, September 1977.
16. A. W. Roscoe. *The Theory and Practice of Concurrency*. Prentice Hall, 1998.
17. Mary Shaw, et al. Abstractions for software architecture and tools to support them. In *IEEE Trans. on Software Engineering*, April 1995.
18. K.J. Sullivan, J. Socha, and M. Marchukov. Using formal methods to reason about architectural standards. In *1997 Intl. Conf. on Software Engineering*, May 1997.

## A Summary of CSP Used in This Paper

We use the following subset of CSP:

- **Processes and Events:** A process describes an entity that can engage in communication events. Events may be primitive or they can have associated data (as in  $e?x$  and  $e!x$ , representing input and output of data, respectively).
- **Prefixing:** A process that engages in event  $e$  and then becomes process  $P$  is denoted  $e \rightarrow P$ .
- **Sequencing:** ("sequential composition") A process that behaves like  $P$  until  $P$  terminates (  $\$$  ) and then behaves like  $Q$ , is denoted  $P;Q$ .
- **Interrupting:** A process that behaves like  $P$  until the occurrence of the first event in  $Q$ , is denoted  $P \Delta Q$ . If  $P$  recognizes the interrupting event,  $P$  must allow it in order to be interrupted.

- **Alternative:** (“external choice”) A process that can behave like P or Q, where the choice is made by the environment, is denoted  $P \square Q$ . (“Environment” refers to the other processes that interact with the process.)
- **Decision:** (“internal choice”) A process that can behave like P or Q, where the choice is made (non-deterministically) by the process itself, is denoted  $P \sqcap Q$ .
- **Named Processes:** Process names can be associated with a (possibly recursive) process expression. Processes may also be subscripted to represent internal state.
- **Parallel Composition:** Processes can be composed using the  $\parallel$  operator. Parallel processes may interact by jointly (synchronously) engaging in events that lie within the intersection of their alphabets. Conversely, if an event  $e$  is in the alphabet of processes P and Q, then P can only engage in the event if Q can also do so. That is, the process  $P \parallel Q$  is one whose behavior is permitted by both P and Q.
- **Refinement:** Process Q refines process P if we can replace P by Q in any context and not know the difference in terms of observable behavior. First, the two processes have the same alphabet of events. Second, all the traces (sequences of events) generated by Q are also traces that P can generate, that is, the behavior of Q is the same, or more restricted than, the behavior of P. Third, after any given trace, Q will accept every event that P itself would accept and may (deterministically or not) refuse to engage in an event that P might (non-deterministically) refuse.

In process expressions  $\rightarrow$  associates to the right and binds tighter than both  $\square$  and  $\sqcap$ . So  $e \rightarrow f \rightarrow P \square g \rightarrow Q$  is equivalent to  $(e \rightarrow (f \rightarrow P)) \square (g \rightarrow Q)$ .

## B Wright Specification of EJB

We include the Wright specification that was used along the paper main body, for reference.

```

Configuration one-Client-one-Bean
  Process SomeBusinessLogic = <...>
  Component TPMonitor = <...>

Component Client (BusinessLogic: Process)
  = ( (  $\square$  e:αBusinessLogic •  $\bar{e}$  → UseRemoteInterface )
     $\sqcap$  (  $\square$  e:αBusinessLogic • (  $\sqcap$  txContext • e!txContext
      → UseRemoteInterface ) ) )
   $\Delta$  txRequiredException → UseRemoteInterface
Port UseHomeInterface = create
  → ( GoHomeInterface
     $\Delta$  noSuchObjectException → UseHomeInterface )
   $\Delta$   $\bar{remove}$  → (  $\$ \square$  removeException →  $\$$  )
Where GoHomeInterface = getEJBMetaData → GoHomeInterface

```

Computation =  $\overline{\text{create}}$   $\rightarrow$  CallBean  
 Where CallBean = ( UseRemoteInterface || GoHomeInterface )  
      $\Delta$  noSuchObjectException  $\rightarrow$   $\overline{\text{create}}$   $\rightarrow$  CallBean )  
      $\Delta$   $\overline{\text{remove}}$   $\rightarrow$  ( §  $\square$  removeException  $\rightarrow$  § )

Component EJBBean (BusinessLogic: Process)  
 alpha Activated =  $\alpha$ BusinessLogic + {ejbRemove}  
 Port BeanHome = newInstance  $\rightarrow$  ejbCreate  $\rightarrow$  §  
 Port JxBean = setContext  $\rightarrow$  GoJxBean  
 Where GoJxBean  
     = ejbPassivate  $\rightarrow$  ejbActivate  $\rightarrow$  GoJxBean  
      $\square$  ejbRemove  $\rightarrow$  §  
 Port BeanRemote = BusinessLogic  
 Port DeploymentDescriptor = queryDeploymentDescriptor?e  
      $\rightarrow$  (  $\square$  txAttribute:{TxNotSupported, TxRequired, TxSupports,  
         TxRequiresNew, TxMandatory} •  
          $\overline{\text{getTxAttribute!txAttribute}}$   $\rightarrow$  DeploymentDescriptor )  
 Computation = Init;((BeanRemote || SwapBean || DeploymentDescriptor )  
      $\Delta$  ejbRemove  $\rightarrow$  § )  
 Where Init = newInstance  $\rightarrow$  setContext  $\rightarrow$  ejbCreate  $\rightarrow$  §  
 Where SwapBean = RUN<sub>Activated</sub>  
      $\Delta$  ejbPassivate  $\rightarrow$  ejbActivate  $\rightarrow$  SwapBean

Connector Container (BusinessLogic: Process)  
 alpha Created =  $\alpha$ UseJxBean \ {setContext, ejbRemove}  
 alpha Activated =  $\alpha$ Container \ {ejbPassivate, ejbActivate}

Role HomeInterface =  $\overline{\text{create}}$   $\rightarrow$  GoHomeInterface  
 Where GoHomeInterface  
     = (  $\overline{\text{getEJBMetaData}}$   $\rightarrow$  GoHomeInterface  
          $\square$  noSuchObjectException  $\rightarrow$  HomeInterface )  
      $\square$   $\overline{\text{remove}}$   $\rightarrow$  ( §  $\square$  removeException  $\rightarrow$  § )  
 Role UseBeanHome = newInstance  $\rightarrow$  ejbCreate  $\rightarrow$  §

Role RemoteInterface = BusinessLogic || TransactionException  
 Where TransactionException  
     =  $\overline{\text{txRequiredException}}$   $\rightarrow$  TransactionException  
 Role UseRemoteInterface = BusinessLogic

Role UseJxBean = setContext  $\rightarrow$  GoJxBean  
 Where GoJxBean  
     = ejbPassivate  $\rightarrow$  ejbActivate  $\rightarrow$  GoJxBean  
      $\square$  ejbRemove  $\rightarrow$  UseJxBean

Role UseDeploymentDescriptor = queryDeploymentDescriptor?e  
      $\rightarrow$  (  $\square$  txAttribute:{TxNotSupported, TxRequired, TxSupports,  
         TxRequiresNew, TxMandatory} •  
          $\overline{\text{getTxAttribute!txAttribute}}$   $\rightarrow$  UseDeploymentDescriptor )

```

Role UseTPMonitor
= NonNestedTransaction; UseTPMonitor
  [] suspendTx?txContext → ( § [] NonNestedTransaction );
                        resumeTx?txContext → UseTPMonitor

Where NonNestedTransaction
= beginTx → ( [] txContext • getTx!txContext → endTx?txContext → § )

Glue = BeanLive
      || SwapBean
      || Delegate
Where BeanLive
= create → newInstance → setContext → ejbCreate
→ ( [] RUNCreated
  Δ remove → ejbRemove → § )
Where SwapBean
= RUNActivated Δ ejbPassivate
→ ( [] e: αRemoteInterface • RemoteInterface.e?txContext
→ ejbActivate → UseRemoteInterface.e → SwapBean )
Where Delegate
= ( [] e: αRemoteInterface •
  ( RemoteInterface.e?txContext → EnforceTxContext(e,txContext)
    [] RemoteInterface.e → CheckTxRequired(e)
  ); Delegate
) [] ejbPassivate → Delegate
Where EnforceTxContext(e: αRemoteInterface, txContext)
= queryDeploymentDescriptor!e
→ ( ( getTxAttribute?TxNotSupported
→ suspendTx!txContext
→ UseRemoteInterface.e
→ resumeTx!txContext → § )
[] ( getTxAttribute?TxSupports
→ UseRemoteInterface.e → § )
[] ( getTxAttribute?TxRequired
→ UseRemoteInterface.e → § )
[] ( getTxAttribute?TxMandatory
→ UseRemoteInterface.e → § )
[] ( getTxAttribute?TxRequiresNew
→ suspendTx!txContext → beginTx → getTx?newTxContext
→ UseRemoteInterface.e
→ endTx!newTxContext → resumeTx!txContext → § ) )
Where CheckTxRequired(e: αRemoteInterface)
= queryDeploymentDescriptor!e
→ ( ( getTxAttribute?TxNotSupported
→ UseRemoteInterface.e → § )
[] ( getTxAttribute?TxSupports
→ UseRemoteInterface.e → § )
[] ( getTxAttribute?TxRequired
→ beginTx → getTx?newTxContext
→ UseRemoteInterface.e

```

```

        → endTx!newTxContext → § )
    [] ( getTxAttribute?TxMandatory
        → txRequiredException → § )
    [] ( getTxAttribute?TxRequiresNew
        → beginTx → getTx?newTxContext
        → UseRemoteInterface.e
        → endTx!newTxContext → § ) )

```

#### Instances

```

A: Client(SomeBusinessLogic)
B: EJBBean(SomeBusinessLogic)
C: Container(SomeBusinessLogic)
T: TPMonitor

```

#### Attachments

```

A.UseHomeInterface as C.HomeInterface
A.UseRemoteInterface as C.RemoteInterface
C.UseBeanHome as B.BeanHome
C.UseRemoteInterface as B.RemoteInterface
C.UseJxBean as B.JxBean
C.UseDeploymentDescriptor as B.DeploymentDescriptor
C.UseTPMonitor as T.Monitor

```

end one-Client-one-Bean.

## C EJB Coding Example

We next present the skeleton of the java files that correspond to a Bean,<sup>17</sup> using a toy accounts payable system for the sake of example. Before we do so, Fig. 21 shows the definitions of the Home and Remote interfaces (**EJBHome** and **EJBObject**, respectively) as they are given in Sun's EJB spec.

In order to code one bean, there are three files that have to be written by the user, corresponding to the Home Interface (suffixed **Home**), the Remote Interface and the bean itself (suffixed **Bean**). Figure 22 shows the Home Interface for the **AccPayable** bean, defining the signature of all the relevant **create** methods. In this toy example, only one **create** method is shown with no arguments. The bean file must define as many **ejbCreate** methods as **create** methods in the **Home** file, with corresponding signatures.

Note that the method definitions in the Remote Interface (Fig. 23) correspond to the signature of the events in the **BusinessLogic** process in the Wright specification. The actual business logic is defined by the corresponding method's body inside the **Bean** file.

Figure 24 shows the contents of the **Bean** file. Note that not only all the business methods have to be defined consistently with the signatures in the file

<sup>17</sup> A Session Bean, to be exact. Note that the characteristics that we presented are shared among Session and Entity Beans, and in fact, the distinction between these two categories of Beans falls out of the scope of this paper.

```

public interface javax.ejb.EJBHome
    extends java.rmi.Remote
{
    public abstract EJBMetaData getEJBMetaData();
    public abstract void remove(Handle handle);
    public abstract void remove(Object primaryKey);
}

public interface javax.ejb.EJBObject
    extends java.rmi.Remote
{
    public abstract EJBHome getEJBHome();
    public abstract Handle getHandle();
    public abstract Object getPrimaryKey();
    public abstract boolean isIdentical(EJBObject obj);
    public abstract void remove();
}

```

Fig. 21. Home and Remote interfaces as specified by Sun.

```

public interface AccPayableHome extends EJBHome
{
    public Tpc create() throws javax.ejb.CreateException,
        java.rmi.RemoteException;
}

```

Fig. 22. Contents of file `AccPayableHome.java`: Home Interface for the Accounts Payable Session Bean

```

public interface AccPayable extends EJBObject
{
    int newOrder( int    customerId,
        Vector lines ) throws RemoteException;
    void payment( int    customerId,
        int    orderId,
        float amount ) throws RemoteException;
}

```

Fig. 23. Contents of file `AccPayable.java`: Remote Interface for the Accounts Payable Session Bean

for the Remote Interface, the user must also define the specific synchronization methods that the container will call according to the bean contract.

```

public class AccPayableBean implements SessionBean
{
    // *****
    // Methods in the remote interface
    public int newOrder( int    customerId,
                        Vector orderLines )
        throws RemoteException
    {
        // register a new order...
    }
    public void payment( int    customerId,
                        int    orderId,
                        float amount    )
        throws RemoteException;
    {
        // perform a payment...
    }

    // *****
    // Synchronization methods called by the Container
    public void ejbCreate ()
    {
        // some initialization ...
    }
    public void ejbActivate() throws RemoteException
    {
        // re-acquire resources...
    }
    public void ejbPassivate() throws RemoteException
    {
        // release locked resources...
    }
    public void ejbRemove() throws RemoteException
    {
        // release locked resources + cleanup...
    }
}

```

Fig.24. Contents of file `AccPayableBean.java`: Accounts Payable Session Bean.