

# LOAN DOCUMENT

PHOTOGRAPH THIS SHEET

DTIC ACCESSION NUMBER

LEVEL

INVENTORY

*BIDVENTING PILOT TEST WORK...*

DOCUMENT IDENTIFICATION

*DEC 93*

**DISTRIBUTION STATEMENT A**  
Approved for Public Release  
Distribution Unlimited

DISTRIBUTION STATEMENT

ACCESSION CODE	
NTIS	GRAM
DTIC	TRAC
UNANNOUNCED	
JUSTIFICATION	
BY	
DISTRIBUTION/	
AVAILABILITY CODES	
DISTRIBUTION	AVAILABILITY AND/OR SPECIAL
<i>A-1</i>	

DISTRIBUTION STAMP

DATE ACCESSIONED

DATE ACCESSIONED

DATE RETURNED

DATE RETURNED

20001226 014

DATE RECEIVED IN DTIC

REGISTERED OR CERTIFIED NUMBER

REGISTERED OR CERTIFIED NUMBER

PHOTOGRAPH THIS SHEET AND RETURN TO DTIC-FDAC

H  
A  
N  
D  
L  
E  
  
W  
I  
T  
H  
  
C  
A  
R  
E

# **PART I**

**Bioventing Pilot Test Work Plan for  
Building 735 Pumphouse  
Grissom AFB, Indiana**

# **PART II**

**Draft Interim Pilot Test Results Report for  
Building 735 Pumphouse  
Grissom AFB, Indiana**

Prepared For

**Air Force Center for Environmental Excellence  
Brooks AFB, Texas**

and

**305 SPTG/DEV  
Grissom AFB, Indiana**

**ES**

**Engineering-Science, Inc.**

**December 1993**

1700 BROADWAY, SUITE 900  
DENVER, COLORADO 80290

**ES  
ENGINEERING-SCIENCE**

*AGM01-03-0585*

DEFENSE TECHNICAL INFORMATION CENTER  
REQUEST FOR SCIENTIFIC AND TECHNICAL REPORTS

Title  
AFCEE Collection

1. Report Availability (Please check one box)

- This report is available. Complete sections 2a - 2f.
- This report is not available. Complete section 3.

2a. Number of  
Copies Forwarded

1 each

2b. Forwarding Date

July, 2000

2c. Distribution Statement (Please check ONE box)

DoD Directive 5230.24, "Distribution Statements on Technical Documents," 18 Mar 87, contains seven distribution statements, as described briefly below. Technical documents MUST be assigned a distribution statement.

- DISTRIBUTION STATEMENT A: Approved for public release. Distribution is unlimited.
- DISTRIBUTION STATEMENT B: Distribution authorized to U.S. Government Agencies only.
- DISTRIBUTION STATEMENT C: Distribution authorized to U.S. Government Agencies and their contractors.
- DISTRIBUTION STATEMENT D: Distribution authorized to U.S. Department of Defense (DoD) and U.S. DoD contractors only.
- DISTRIBUTION STATEMENT E: Distribution authorized to U.S. Department of Defense (DoD) components only.
- DISTRIBUTION STATEMENT F: Further dissemination only as directed by the controlling DoD office indicated below or by higher authority.
- DISTRIBUTION STATEMENT X: Distribution authorized to U.S. Government agencies and private individuals or enterprises eligible to obtain export-controlled technical data in accordance with DoD Directive 5230.25, Withholding of Unclassified Technical Data from Public Disclosure, 6 Nov 84.

2d. Reason For the Above Distribution Statement (in accordance with DoD Directive 5230.24)

2e. Controlling Office

HQ AFCEE

2f. Date of Distribution Statement  
Determination

15 Nov 2000

3. This report is NOT forwarded for the following reasons. (Please check appropriate box)

- It was previously forwarded to DTIC on \_\_\_\_\_ (date) and the AD number is \_\_\_\_\_
- It will be published at a later date. Enter approximate date if known. \_\_\_\_\_
- In accordance with the provisions of DoD Directive 5200.12, the requested document is not supplied because: \_\_\_\_\_

Print or Type Name

Laura Palmer

Telephone

310-536-4131

Signature

[Signature]

Accession

MOI-03-0585

**PART I**  
**BIOVENTING PILOT TEST WORK PLAN**  
**FOR**  
**BUILDING 735 PUMPHOUSE**  
**GRISSOM AFB, INDIANA**

**December 1993**

**Prepared for:**

**Air Force Center for Environmental Excellence**  
**Brooks AFB, Texas**

**and**

**305 SPTG/DEV**  
**Grissom Air Force Base, Indiana**

**by:**

**Engineering-Science, Inc.**  
**1700 Broadway, Suite 900**  
**Denver, Colorado**

**CONTENTS**  
**PART I**  
**BIOVENTING PILOT TEST WORK PLAN FOR**  
**BUILDING 735 PUMPHOUSE**  
**GRISSOM AFB, INDIANA**

	<u>Page</u>
1.0 Introduction .....	I-1
2.0 Site Description .....	I-1
2.1 Site Location and History.....	I-1
2.2 Site Geology.....	I-2
2.3 Site Contaminants.....	I-5
3.0 Site-Specific Activities.....	I-5
3.1 Site Layout .....	I-6
3.1.1 Phase 1.....	I-6
3.1.2 Phase 2.....	I-6
3.2 Soil Borings .....	I-6
3.3 Vent Well.....	I-9
3.4 Monitoring Points .....	I-9
3.5 Handling of Drill Cuttings .....	I-9
3.6 Soil and Soil Gas Sampling .....	I-9
3.6.1 Soil Samples.....	I-9
3.6.2 Soil Gas Samples .....	I-12
3.7 Blower System .....	I-12
3.8 <i>In Situ</i> Respiration Test.....	I-12
3.9 Air Permeability Test .....	I-14
3.10 Installation of 1-Year Pilot Test Bioventing System .....	I-14
4.0 Exceptions to Protocol Procedures.....	I-15
5.0 Base Support Requirements .....	I-15
5.1 Test Preparation.....	I-15
5.2 Initial Pilot Test.....	I-16
5.3 Extended Pilot Test.....	I-16
6.0 Project Schedule .....	I-16
7.0 Points of Contact .....	I-17
8.0 References .....	I-17

Appendix A - Health and Safety Plan

## FIGURES

<u>No.</u>	<u>Title</u>	<u>Page</u>
2.1	Building 735 Location with Respect to Base.....	I-3
2.2	Site Layout Showing Previously Identified Extent of Soil TPH Contamination.....	I-4
3.1	Proposed Phase 1 Vent Well and Vapor Monitoring Point Locations.....	I-7
3.2	Proposed Phase 1 and Phase 2 Vent Well and Vapor Monitoring Point and Blower Locations.....	I-8
3.3	Proposed Injection/Vent Well Construction Detail .....	I-10
3.4	Proposed Monitoring Point Construction Detail.....	I-12
3.5	Proposed Blower System Instrumentation Diagram for Air Injection .....	I-13

## DRAFT

# BIOVENTING TEST WORK PLAN FOR BUILDING 735 PUMPHOUSE GRISSOM AFB, INDIANA

## 1.0 INTRODUCTION

This work plan presents the scope of an *in situ* bioventing pilot test for treatment of fuel-contaminated soils at the Building 735 pumphouse at Grissom Air Force Base (AFB), Indiana. The pilot test has three primary objectives: 1) to assess the potential for supplying oxygen throughout the contaminated soil interval, 2) to determine the rate at which indigenous microorganisms will degrade fuel when stimulated by oxygen-rich soil gas, and 3) to evaluate the potential for sustaining these rates of biodegradation until fuel contamination is remediated to concentrations below regulatory standards.

The pilot test will be conducted in two phases. One vent well (VW) and four monitoring points (MPs) will be installed during the first phase. The initial stage will also include an *in situ* respiration test and an air permeability test. This initial testing is expected to take approximately 1 week. If bioventing proves to be feasible at this site, initial pilot test data will be used to design and install an expanded pilot system during the second phase of work. The second phase, which will immediately follow the initial phase, will include the drilling of additional soil borings, installation of additional VWs and MPs, and installation of a bioventing system that will be monitored over a 1-year period. The objective of the second phase will be to biovent as much of the unsaturated soils as possible during the one year test.

Additional background information on the development and recent success of the bioventing technology is found in the *Test Plan and Technical Protocol For A Field Treatability Test For Bioventing* (Hinchee et al., 1992). This protocol document will also serve as the primary reference for pilot test well designs and detailed procedures which will be used during the test.

## 2.0 SITE DESCRIPTION

### 2.1 Site Location and History

Building 735 is a pumphouse for eight 50,000-gallon JP-4 jet fuel underground storage tanks (USTs) which feed a fueling system at the base. The building is located south of the main base complex adjacent to the operation apron of the airfield (Figure 2.1). The area of concern is located southeast of the building. Figure 2.2 shows the

location of existing monitoring wells within and adjacent to the area of identified total recoverable petroleum hydrocarbon (TRPH) contamination. The location of Building 735 with respect to the base is shown in Figure 2.1. The following information was summarized from the *Project Final Report, Remedial Action Investigation of Leaking Underground Storage Tanks, Grissom Air Force Base, IN* prepared by Twin City Testing Corporation (TCT) in March 1992.

In February 1991, free product thought to be JP-4 jet fuel was observed on the ground surface near the southeastern corner of Building 735. The source of the release was believed to be below grade. Four potential sources of JP-4 at Building 735 were identified by Grissom AFB personnel in July 1991, and included:

- Leaks in USTs and associated piping. A leak test performed by Tracer Research Corp. (TRC) in April 1991 appeared to indicate that a leak in tank #3 was the primary source for the February release.
- Leaks in pipelines running to and from Building 735.
- Fuel spills on the airfield apron which could migrate on or below the surface toward the pumphouse area.
- Leaks in the sewer line that connects floor drains in Building 735 to an underground "slop tank" located southeast of the building.

A representative from the Grissom AFB Utilities Department stated that similar releases have been observed in this vicinity periodically for the past 17 years. During periods of wet weather when the groundwater table is elevated, free product occasionally is observed on the floor of the pumphouse.

After observing the release in February 1991, six monitoring wells were installed by Air Force personnel near Building 735. The well locations are shown in Figure 2.2. Free product was observed in wells 2, 3, 4, and 6 on February 19, 1991. More than 50 gallons of oil/water mixture was pumped from wells 1 through 4 and 6 from late February through early March 1991. On March 4, 1991, all wells were free of measurable quantities of petroleum product.

In April 1991, tank #3 was removed from service in an attempt to remediate the source of the February release. This action was a result of TRC's April 1991 conclusion that tank #3 was the primary source of the release. On October 24, 1991, free product was found in well 2. On December 17, the depth of this product was measured to be approximately 6 inches. Because no petroleum contamination was reported for any of the wells in March, and tank #3 was removed shortly thereafter, the discovery of contamination in December 1991 indicated that tank #3 may not have been the sole source of contamination.

## 2.2 Site Geology

Surficial geology at Grissom AFB consists of an average of 60 feet of glacial deposits. Deposits are mainly composed of a relatively impermeable silty-clayey till. Thin sand and gravel lenses are present in areas where the till layer is the thickest.



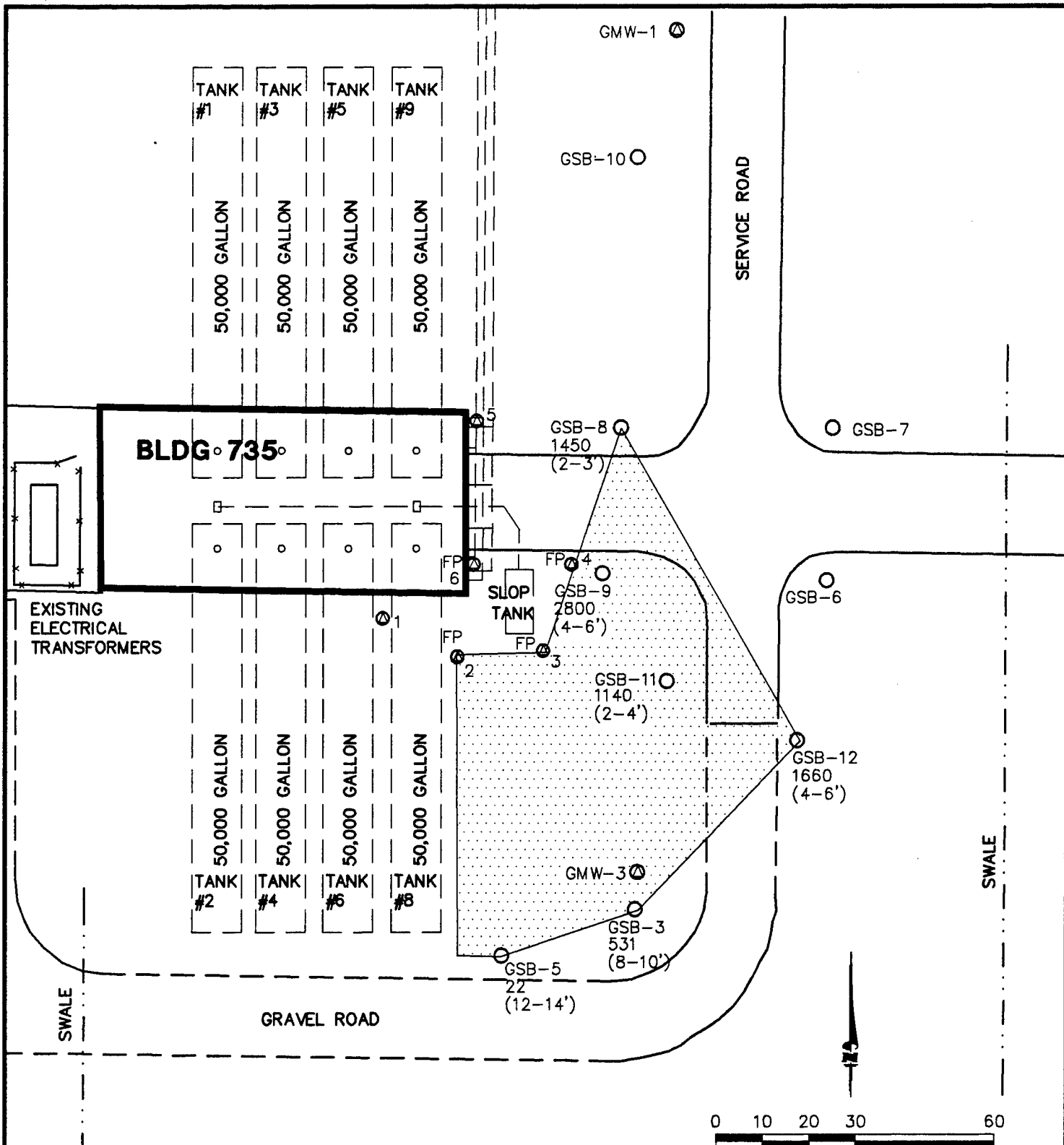

**LEGEND**

- ⊗ EXISTING MONITORING WELL
- EXISTING SOIL BORING

1450 SOIL TRPH LABORATORY RESULTS IN mg/kg WITH  
(2-3') DEPTH INTERVAL (feet bgs) IN PARENTHESES



AREA OF DETECTED SOIL TRPH CONTAMINATION



FREE PRODUCT DETECTED IN WELL IN MARCH 1991 (TCT, 1992)

**FIGURE 2.2**  
**SITE LAYOUT SHOWING**  
**PREVIOUSLY IDENTIFIED**  
**EXTENT OF**  
**SOIL TRPH CONTAMINATION**

**BUILDING 735**  
**GRISSOM AFB, INDIANA**

**ENGINEERING-SCIENCE, INC.**  
 Denver, Colorado



After TCT, 1992.

The Liston Creek Formation underlies the glacial deposits at Grissom AFB. This dolomitic limestone is 50 to 70 feet thick, and is primary source of groundwater supplies at and in the vicinity of Grissom AFB. Flow within this aquifer is to the northeast.

Soils in the pilot test area are subject to brief but frequent flooding. From December to May, the depth of the water table ranges from 0.1 to 1.0 foot below ground surface (bgs) (TCT, 1992). Local topography causes surface runoff to accumulate near the pumphouse, causing additional flooding. During the drier summer months, the depth to water increases to approximately 6 to 9 feet bgs. Shallow groundwater flow in the glacial till beneath the site is in a southerly direction.

### 2.3 Site Contaminants

The primary contaminants at this site are petroleum hydrocarbons which have been detected in the soils and groundwater at depths ranging from approximately 0 to 12 feet bgs. TRPH concentrations exceeding 1,000 milligrams per kilogram (mg/kg) have been detected in the soils at a depth of 2 to 6 feet at four locations. Contaminant migration appears to be toward the southeast.

The highest TRPH concentration (2,800 mg/kg) was detected in soil from soil boring GSB-9 at a depth of 4-6 feet bgs. The previously identified extent of soil TRPH contamination (TCT, 1992) is shown on Figure 2.2. However, it is likely that the extent of TRPH-contaminated soil extends beyond the limits shown on Figure 2.2, and may include some of the area beneath Building 735 near tank #3 and the area southeast of soil boring GSB-12.

### 3.0 SITE-SPECIFIC ACTIVITIES

The purpose of this section is to describe the bioventing pilot test work that will be performed by Engineering-Science, Inc. (ES) at Building 735. Activities to be performed include a limited soil gas survey; borehole drilling and soil sampling; siting and construction of VWs and MPs; an *in situ* respiration test; an air permeability test; the installation of a long-term bioventing pilot test system; and a system startup test. Soil and soil gas sampling procedures and the blower configuration that will be used to inject air (oxygen) into contaminated soils through the VWs are also discussed in this section.

No dewatering will take place during the pilot test. Pilot test activities will be confined to unsaturated soils remediation. As a result, soils remediation will be most productive during dry summer months when the maximum amount of fuel-contaminated soil would be exposed to the bioventing process. Without some form of dewatering, it is doubtful whether complete site remediation can be achieved.

Installation of the VWs and MPs will be performed in two phases. In the first phase, one VW and four MPs will be installed. Following the Phase 1 installation, air permeability and respiration tests will be performed to determine the radius of pressure and oxygen influence for a single VW. If initial test results from Phase 1 are positive, a second phase of work will begin immediately. During Phase 2, an estimated 3 to 5 additional VWs will be installed, with locations and spacing being determined by Phase

1 results. If the results of Phase 1 indicate that bioventing technology is not suitable for this site (poor pressure/oxygen response or little biological activity) the decision to proceed with Phase 2 will be reevaluated with the Air Force Center for Environmental Excellence (AFCEE) and the base.

### **3.1 Site Layout**

#### **3.1.1 Phase 1**

A general description of criteria for siting a central VW and vapor MPs is included in the protocol document (Hinchee et al., 1992). Figure 3.1 illustrates the proposed locations of the central VW and MPs at this site. The final locations of these wells may vary slightly from the proposed locations if significant fuel contamination is not observed in the boring for the VW. Based on available site investigation data, the central VW should be located near existing soil boring GSB-11. Soils in this area are expected to be oxygen depleted (<2%) due to high hydrocarbon levels, and increased biological activity should be stimulated by oxygen-rich soil gas ventilation during pilot test operations.

Due to the relatively shallow depth to groundwater at this site and the experience that ES has had with similar soil types, the potential radius of venting influence around the central air injection well is expected to be 20 to 35 feet. Three vapor MPs (MPA, MPB, and MPC) will be located within a 35-foot radial distance of the central VW. A fourth MP will be located in an uncontaminated area upgradient of the site and will be used to measure background levels of oxygen and carbon dioxide and to determine if natural carbon sources are contributing to oxygen uptake during the *in situ* respiration test. If an existing onsite groundwater monitoring well can be used as a background MP, the fourth MP will not be installed.

#### **3.1.2 Phase 2**

If the results from Phase 1 testing are positive, a maximum of 7 additional soil borings will be drilled and sampled, and an estimated 3 to 5 additional VWs will be installed in the borings at the proposed locations shown on Figure 3.2. Soil borings not completed as VWs or MPs will be abandoned. Locations shown on Figure 3.2 are approximate and are based on a radius of influence of approximately 25 feet for the VWs. The exact locations will be determined based on the radius of pressure and oxygen influence of the Phase 1 VW (VW-1), existing utilities, and other physical site features. Determination of the extent of soil contamination will be based upon the results of previous investigations (TCT, 1992) and field screening results from the proposed soil borings.

### **3.2 Soil Borings**

Soil borings will be advanced to an estimated maximum depth of 15 feet using hollow stem auger techniques. Soil samples will be collected for lithologic description, field screening, and laboratory analysis as described in Section 3.6. Borings not completed as VWs or MPs will be abandoned using cement/bentonite grout.

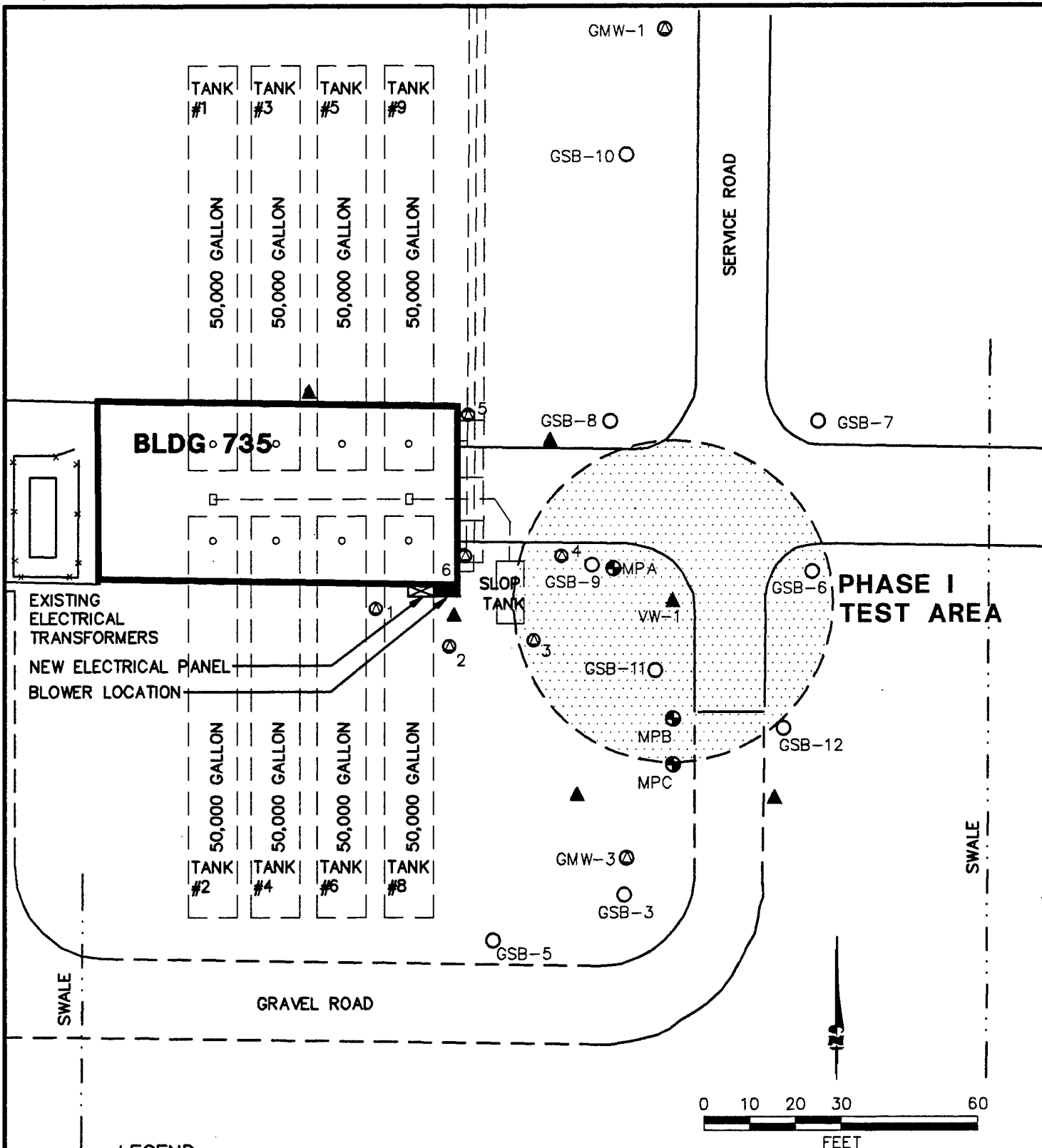

**LEGEND**

- ⊙ EXISTING MONITORING WELL
- EXISTING SOIL BORING
- ▲ PROPOSED VENT WELL (AIR INJECTION)
- ⊕ PROPOSED VAPOR MONITORING POINT

**FIGURE 3.1**  
**PROPOSED PHASE I**  
**VENT WELL AND**  
**VAPOR MONITORING POINT**  
**LOCATIONS**

BUILDING 735  
 GRISSOM AFB, INDIANA

ENGINEERING-SCIENCE, INC.  
 Denver, Colorado



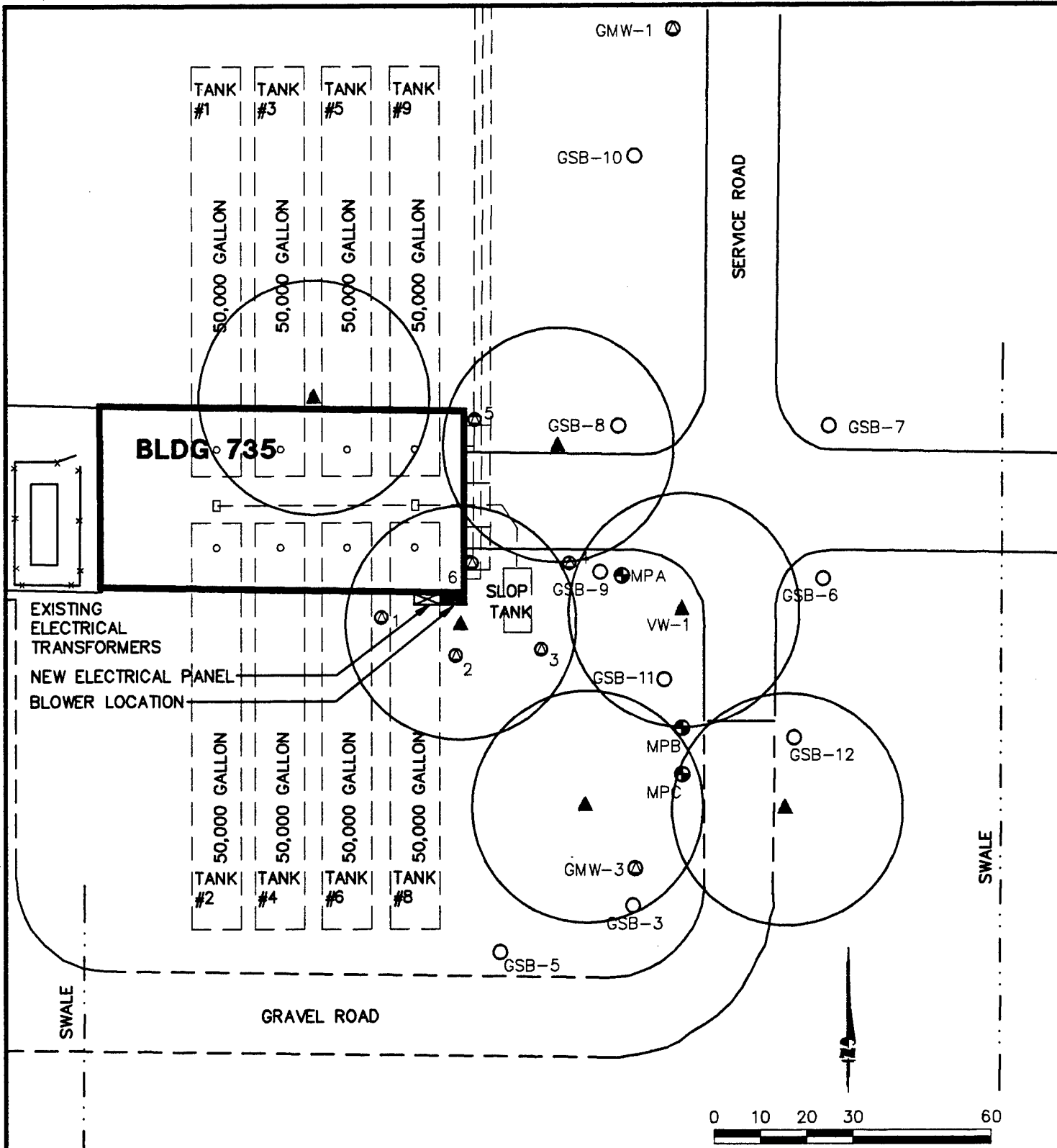

EXISTING ELECTRICAL TRANSFORMERS  
 NEW ELECTRICAL PANEL  
 BLOWER LOCATION

**LEGEND**

- ⊙ EXISTING MONITORING WELL
- EXISTING SOIL BORING
- ▲ PROPOSED VENT WELL (AIR INJECTION)
- ⊕ PROPOSED VAPOR MONITORING POINT
- POTENTIAL AREA OF OXYGEN INFLUENCE



**FIGURE 3.2**  
**PROPOSED PHASE I AND PHASE II VENT WELL, MONITORING POINT, AND BLOWER LOCATIONS**

**BUILDING 735**  
**GRISSOM AFB, INDIANA**

**ENGINEERING-SCIENCE, INC.**  
 Denver, Colorado



### **3.3 Vent Well**

The VWs will be constructed of 4-inch inside-diameter (ID) schedule 40 polyvinyl chloride (PVC), with a 10-foot interval of 0.04-inch slotted screen set at 4.5 to 14.5 feet bgs. The screened interval will extend beneath the existing groundwater surface to take advantage of possible lower groundwater levels (increased depth of unsaturated soil) in the future. Lower groundwater level could result from unusually dry weather or future dewatering activities at this site. Flush-threaded PVC casing and screen with no organic solvents or glues will be used. The filter pack will be clean, well-rounded silica sand with a 6-9 grain size, and will be placed in the annular space of the screened interval. A 2-foot layer of bentonite pellets, hydrated in place with potable water, will be placed directly over the filter pack. The layer of pellets will prevent the addition of grout from saturating the filter pack. A bentonite/cement grout will then be introduced into the remaining annular space above the bentonite pellets to produce an air-tight seal above the screened interval. A complete seal is critical to prevent injected air from short circuiting to the surface during the bioventing test. Figure 3.3 illustrates the proposed VW construction for this site.

### **3.4 Monitoring Points**

A typical multidepth vapor MP installation for this site is shown in Figure 3.4. Soil gas oxygen and carbon dioxide concentrations will be monitored at depth intervals of approximately 3 to 4 feet and 8 to 9 feet at each location. A vapor probe will be installed within a 2-foot-thick sand pack interval at each depth interval. Thermocouples will be installed at the same depths as the vapor probes in MPA to monitor seasonal soil temperature variations. Multidepth monitoring will confirm that the entire soil profile is receiving oxygen and will be used to measure fuel biodegradation rates at each depth. The deep monitoring point may be submerged below the water table during the wet season but this depth is necessary for measuring oxygen influence during dry summer months. The spaces between monitoring intervals will be sealed with granular bentonite, hydrated in place, to isolate the intervals. Additional details on VW and MP construction are found in Section 4 of the protocol document.

### **3.5 Handling of Drill Cuttings**

Cuttings will be collected in U.S. Department of Transportation (DOT) approved containers. The containers will be labeled, staged on pallets, and left onsite. Drill cuttings will become the responsibility of Grissom AFB, or their designated contractor, and will be analyzed and disposed of in accordance with the current procedures.

### **3.6 Soil and Soil Gas Sampling**

#### **3.6.1 Soil Samples**

A total of four soil samples will be collected from the pilot test area and from the background MP borehole during the installation of the VW and MPs. Sampling procedures will follow those outlined in the protocol document. One sample will be collected from the most contaminated interval of the VW boring, and one sample

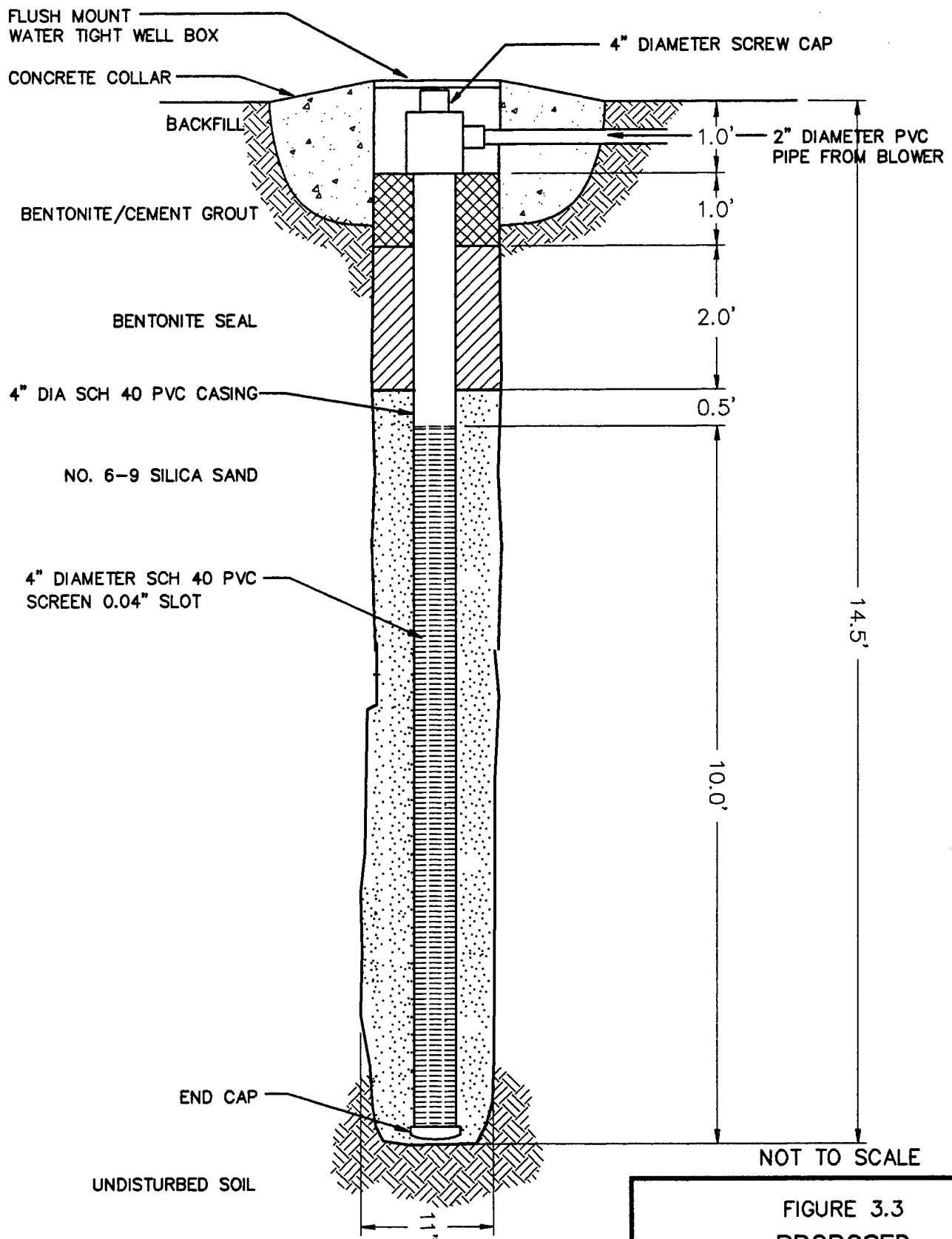
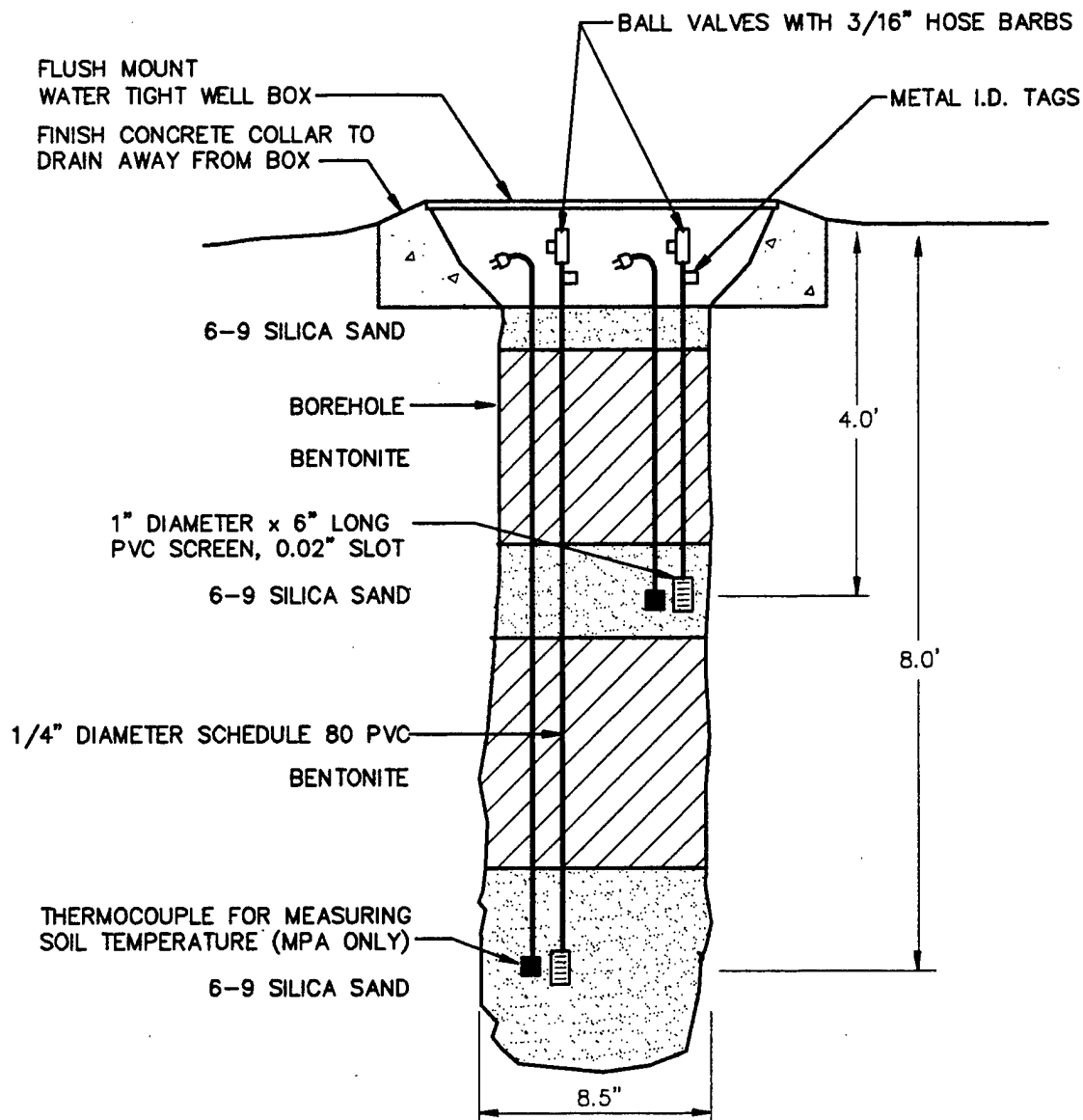

FIGURE 3.3  
 PROPOSED  
 INJECTION/VENT WELL  
 CONSTRUCTION DETAIL

BUILDING 735  
 GRISSOM AFB, INDIANA

ENGINEERING-SCIENCE, INC.  
 Denver, Colorado





NOT TO SCALE

FIGURE 3.4  
PROPOSED  
MONITORING POINT  
CONSTRUCTION DETAIL

BUILDING 735  
GRISSOM AFB, INDIANA

ENGINEERING-SCIENCE, INC.  
Denver, Colorado

ES

will be collected from the interval of highest apparent contamination in each of the borings for the two MPs closest to the VW. Soil samples will be analyzed for TRPH, benzene, toluene, ethylbenzene, and xylenes (BTEX), soil moisture, pH, particle sizing, alkalinity, total iron, and nutrients. One additional soil sample will be collected from the boring for the background MP and analyzed for total kjeldahl nitrogen (TKN) only.

Soil samples for TRPH and BTEX analysis will be collected using a split-spoon sampler containing brass tube liners. Soil samples collected in the brass tubes for TRPH and BTEX analyses will be immediately trimmed, and the ends will be sealed with aluminum foil or Teflon<sup>®</sup> fabric held in place by plastic caps. Soil samples collected for physical parameter analyses will be placed into glass sample jars or other appropriate sample containers. Soil samples will be labelled following the nomenclature specified in the protocol document (Section 5), wrapped in plastic, and placed in a cooler for shipment. A chain-of-custody form will be filled out, and the cooler will be shipped to the Pace-ES laboratory in Berkeley, California for analysis. This laboratory has been audited by the Air Force and meets all quality assurance/quality control (QA/QC) and certification requirements for the State of California.

### 3.6.2 Soil Gas Samples

A total hydrocarbon vapor analyzer will be used during drilling to screen split-spoon samples for intervals of high fuel contamination. During Phase 1, initial soil gas samples will be collected in SUMMA<sup>®</sup> canisters, in accordance with the *Bioventing Field Sampling Plan* (ES, 1992), from VW-1 and from the MPs closest to and furthest from VW-1. Additionally, these soil gas samples will be used to predict potential air emissions, to determine the reduction in BTEX and total volatile hydrocarbons (TVH) during the 1-year test, and to detect any migration of these vapors from the source area.

Soil gas sample canisters will be placed in a small cooler and packed with foam pellets to prevent excessive movement during shipment. Samples will not be sent on ice to prevent condensation of hydrocarbons. A chain-of-custody form will be filled out, and the cooler will be shipped to the Air Toxics, Inc. laboratory in Rancho Cordova, California for analysis.

### 3.7 Blower System

A 3-horsepower (hp) positive-displacement blower capable of injecting air over a wide range of flow rates and pressures will be used to conduct the initial air permeability test and *in situ* respiration test during Phase 1. Figure 3.5 is a schematic of a typical air injection system used for pilot testing. The maximum power requirement anticipated for this pilot test is 230-volt, single-phase, 30-amp service. Additional details on power supply requirements are described in Section 5.0, Base Support Requirements.

### 3.8 In Situ Respiration Test

The objective of the Phase 1 *in situ* respiration test is to determine the rate at which soil bacteria degrade petroleum hydrocarbons. Respiration tests will be

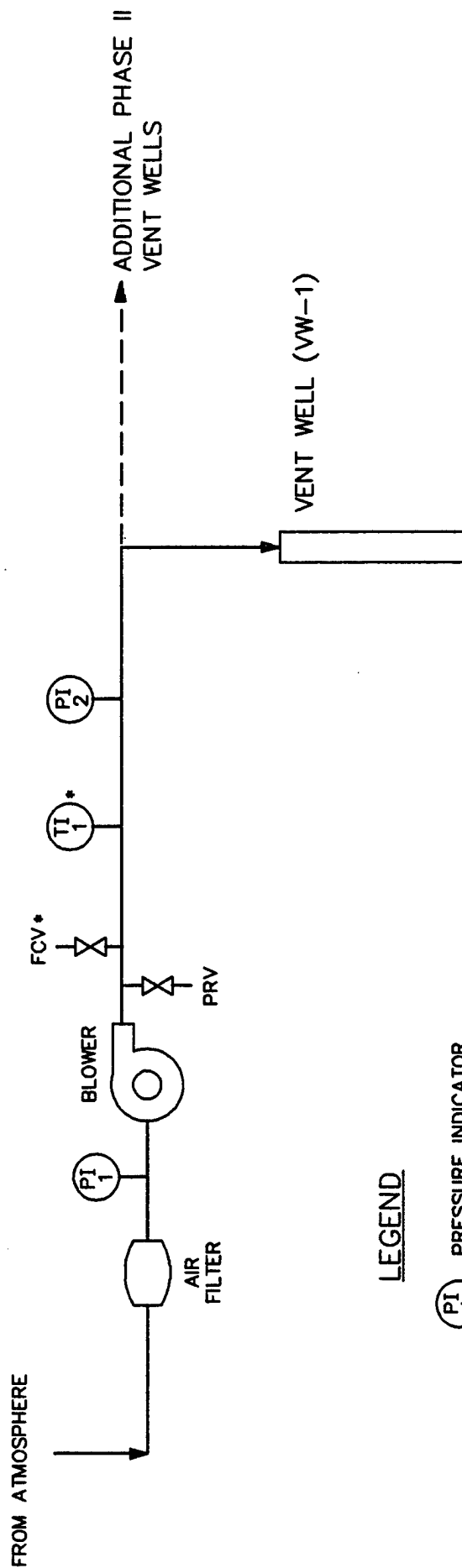

LEGEND



-  PRESSURE INDICATOR
-  TEMPERATURE INDICATOR
- FCV FLOW CONTROL VALVE
- PRV PRESSURE RELIEF VALVE
- \* OPTIONAL

FIGURE 3.5  
 PROPOSED BLOWER SYSTEM  
 INSTRUMENTATION DIAGRAM  
 FOR AIR INJECTION

BUILDING 735  
 GRISSOM AFB, INDIANA  
 ENGINEERING-SCIENCE, INC.  
 Denver, Colorado



performed at selected MPs where biodegradation of hydrocarbons is indicated by low oxygen levels and elevated carbon dioxide concentrations in the soil gas. One-cubic-foot-per-minute (cfm) pumps will be used to inject air into selected MP depth intervals containing low levels (<2%) of oxygen. A 20-hour air injection period will be used to oxygenate local contaminated soils during Phase 1. At the end of the 20-hour air injection period, the air supply will be cut off, and oxygen and carbon dioxide levels will be monitored for the following 48 to 72 hours. The decline in oxygen and increase in carbon dioxide concentrations over time will be used to estimate rates of bacterial degradation of fuel residuals. Helium will also be injected at the selected MPs to determine the effectiveness of the bentonite seals between screened intervals. Additional details on the *in situ* respiration test are presented in Section 5.7 of the protocol document.

### **3.9 Air Permeability Test**

The objective of the Phase 1 air permeability test is to determine the extent of the subsurface that can be oxygenated using one air injection VW. Air will be injected into VW-1 using the blower unit, and pressure response will be measured at each MP with differential pressure gauges to determine the region influenced by the unit. Oxygen will also be monitored in the MPs to verify that oxygen levels in the soil increase as the result of air injection. One air permeability test lasting approximately 4 to 8 hours will be performed during Phase 1.

### **3.10 Installation of 1-Year Pilot Test Bioventing System**

If the results of Phase 1 pilot testing are positive, a long-term bioventing system will be installed at Building 735. The base will be requested to provide power, including 230-volt, 30-amp service and a breaker box with one 230-volt receptacle and two 110-volt receptacles. Depending on the availability of a base electrician, a base electrician or a licensed electrician subcontracted to ES will assist in wiring the blowers to line power.

The system will consist of a central blower system, located near the southeast corner of Building 735, manifolded to all VWs. The blower will be a 2.5-hp regenerative blower capable of injecting air at 2 pounds per square inch (psi) and 95 cfm. The system will include controls to automatically deactivate the system during periods of high groundwater levels and restart the system when the groundwater falls below a predetermined level. The blower will be housed in a small, prefabricated shed to provide protection from the weather.

The system will be in operation for 1 year, and every 6 months ES personnel will conduct *in situ* respiration tests to monitor the long-term performance of this bioventing system. At the end of 1 year of testing, the performance of the system will be evaluated. AFCEE, the base, and ES will then determine if continued operation is warranted.

Weekly system checks will be performed by Grissom AFB personnel. If required, major maintenance of the blower unit will be performed by ES personnel. Detailed blower system information and a maintenance schedule will be included in the

operation and maintenance (O&M) manual to be provided to the base. More detailed information regarding the test procedures can be found in the protocol document.

#### **4.0 EXCEPTIONS TO PROTOCOL PROCEDURES**

The procedures that will be used to measure the air permeability of the soil and *in situ* respiration rates are described in Sections 4 and 5, respectively, of the protocol document (Hinchee et al., 1992). Exceptions to the protocol will include possible Phase 2 installation of additional VWs and MPs as necessary for an expanded multi-VW, rather than a single-VW, bioventing system.

#### **5.0 BASE SUPPORT REQUIREMENTS**

##### **5.1 Test Preparation**

The following base support is needed prior to the arrival of the Phase 1 drilling subcontractor and the ES pilot test team:

- Confirmation of regulatory approval to conduct bioventing pilot tests.
- Assistance in obtaining drilling and digging permits.
- Installation of a new breaker box at Building 735, mounted on the building wall as close as practical to the proposed blower location (Figure 3.2).
- The breaker box should include 230-volt, 30-amp, single-phase service with one 230-volt receptacle and two 110-volt receptacles.
- Provision of any paperwork required to obtain gate passes and security badges for approximately three ES employees, two drillers, and an electrician (if a base electrician is not available). Vehicle passes will be needed for one truck and trailer, and a drill rig.

##### **5.2 Initial Pilot Test**

During the initial testing, the following base support is needed:

- Twelve square feet of desk space and a telephone in a building located as close to the site as practical.
- Parking space for one 8x20-foot field trailer located as close to the pilot test area as possible.
- The use of a facsimile machine for transmitting 15 to 20 pages of test results.
- A designated area located as close to the site as practical where the driller can decontaminate augers and other equipment between borings.
- Acceptance of responsibility for drill cuttings from VW and MP borings, including any drum sampling to determine hazardous waste status. If ES is to transfer custody of barrels to another contractor working on the base, assistance in arranging this transfer will also be needed.

### 5.3 Extended Pilot Test

During the 1-year extended pilot test, base personnel will be required to perform the following activities:

- Check the blower system once per week to ensure that it is operating and to record the air injection pressure and temperature. ES will provide a brief training session on this procedure.
- Arrange site access for an ES technician to conduct *in situ* respiration tests at approximately 6 months and 1 year after the initial pilot test.
- If the blower stops working, notify Mr. John Hall or Mr. Doug Downey of ES-Denver, (303) 831-8100; or Capt Chung Yen of AFCEE, (512) 536-4331.

### 6.0 PROJECT SCHEDULE

The following schedule is contingent upon timely approval of this pilot test work plan and fulfillment of base support requirements.

<u>Event</u>	<u>Date</u>
Draft Test Work Plan to AFCEE/Grissom AFB	April 23, 1993
Begin Initial Pilot Test	October 13, 1993
Interim Results Report	December 30, 1993
Respiration Test	July 1994
Final Respiration Test	October 1994

### 7.0 POINTS OF CONTACT

Lt Gina Oliver  
305 SPTG/DEV  
Grissom AFB, IN 46971-5000  
(317) 688-4576

Maj Ross Miller/Capt Chung Yen  
AFCEE/EST  
Brooks AFB, TX 78235-5000  
(512) 536-4331

Mr. Doug Downey  
Engineering-Science, Inc.  
1700 Broadway, Suite 900  
Denver, CO. 80290  
(303) 831-8100  
Fax (303) 831-8208

## 8.0 REFERENCES

- Engineering-Science, Inc. 1992. *Field Sampling Plan for AFCEE Bioventing*. Denver, Colorado.
- Hinchee, R.E., Ong, S.K., Miller, R.N., Downey, D.C., Frandt, R. 1992. *Test Plan and Technical Protocol for a Field Treatability Test for Bioventing*. January.
- Twin City Testing Corporation, 1992. *Final Project Final Report. Remedial Action Investigation, Leaking Underground Storage Tanks, Grissom Air Force Base, IN*. March.

APPENDIX A

HEALTH AND SAFETY PLAN



## 1.0 INTRODUCTION

This addendum modifies the existing *Program Health and Safety Plan for the Bioventing Test Initiative* (Engineering-Science, Inc., 1992), for conducting bioventing pilot tests at United States Air Force facilities under contract number F33615-90-D-4014.

This addendum outlines the site-specific requirements and provides site-specific information for work to be conducted at Grissom AFB, Indiana. The site to be investigated through pilot testing is Building 735 Pumphouse.

Two additional documents providing information regarding activities to be performed on this site are the bioventing treatability test protocol document (Hinchee et al., 1992) and the site-specific Bioventing Test Work Plan for Grissom AFB.

Included or referenced in this addendum are site-specific descriptions, history and proposed bioventing pilot test activities; hazard evaluation of known or suspected chemicals; personal protective equipment (PPE); personnel decontamination procedures; site-specific training and medical monitoring requirements; air monitoring; site control procedures; employee exposure monitoring; and emergency response procedures.

## 2.0 SITE DESCRIPTION, HISTORY, AND SITE-SPECIFIC ACTIVITIES

The site description, history, and pilot test activities to be performed at this site are outlined in the site-specific work plan entitled *Bioventing Pilot Test Work Plan for Building 735 Pumphouse, Grissom AFB, Indiana*. A brief listing of planned site-specific activities follows.

Services to be performed by ES at this site will include siting and construction of air injection vent wells and four monitoring points (MPs) during site investigation activities. Activities at this site will include an *in situ* respiration test, an air permeability test and installation of a blower system for air injection.

The objective of the pilot test is to determine if bioventing is an effective means of remediating soil contamination at this site. Pilot test data may be used to design an expanded remediation system and to estimate the time required for site cleanup.

## 3.0 SITE-SPECIFIC EMPLOYEE TRAINING AND MEDICAL MONITORING REQUIREMENTS

See Section 4 of the program health and safety plan (Engineering-Science, Inc., 1992) for guidance.

## 4.0 HAZARD EVALUATION

### 4.1 Chemical Hazards

General hazards are addressed in the program health and safety plan. Site-specific hazards are identified below.

Chemicals known or suspected to occur at Building 735 include petroleum hydrocarbon fuel components benzene, toluene, ethylbenzene, and xylenes (BTEX) and total petroleum hydrocarbons.

#### **4.2 Physical hazards**

Potential physical hazards at this site include risks associated with the installation/operation of bioventing equipment such as underground utilities; overhead utilities; drilling activities; electrical equipment; heavy equipment; motor vehicles; slip, trip, and fall hazards; noise; and heat stress.

Protection standards for physical hazards are contained in Section 7 of the program health and safety plan.

#### **5.0 AIR MONITORING**

During operations that disturb site soils, a hydrocarbon detector or photoionization detector (PID or equivalent) will be used to measure ambient air concentrations in the worker breathing zone. If the hydrocarbon detector exceeds a reading of 1 ppm for a one-minute period, site workers will don full facepiece air-purifying respirators (APR) equipped with organic vapor cartridges (NIOSH approved). The contaminated zone can then be reentered with a benzene-sensitive Dräger® tube and PID. If benzene concentrations are less than 1 ppm and the PID reading is less than 50 ppm (the TLV for toluene), the work site can be reentered without a respirator. (Note: By locating yourself upwind of drilling operations or general windblown hazards, much of this procedure can be avoided). If benzene concentrations are greater than 1 ppm and a safe upwind location cannot be identified, respirators will be used. If benzene concentrations exceed 5 ppm and a safe upwind location cannot be identified, work will cease.

Work will not be performed on sites requiring Level B respiratory protection. (Level B operations require approval from corporate health and safety.) The site health and safety officer will determine whether it is safe to continue activities without respiratory protection or assign an upgrade to Level C protection. Flammable vapor monitoring will be conducted if potentially flammable atmospheres occur. See Sections 8 and 11 of the program health and safety plan for specific guidance.

#### **6.0 SITE CONTROL PROCEDURES**

Site control measures will be followed in order to minimize potential contamination of workers, protect the public from potential site hazards, and control access to the sites. Site control involves the physical arrangement and control of the operation zones and the methods for removing contaminants from workers and equipment. See Section 9 of the program health and safety plan for guidance.

Specific site control procedures at this site will include establishment of site work zones whenever employees are wearing respiratory protection. Unauthorized personnel will be restricted from entering the immediate work area.

## 7.0 PERSONAL PROTECTIVE EQUIPMENT

It is anticipated that Level D respiratory protection, with a contingency provision for the use of Level C will be used at this site. Additional guidelines for the selection of respiratory protection at this site is contingent upon the discovery of benzene vapors in the worker breathing zone while performing site activities. Site crews will assess the need for respiratory protection, or PPE, as applicable.

Protective clothing to be used at this site includes:

- Hard hats
- Safety glasses
- Suits (Tyvek® or Saranex®)
- Respirator, if needed (APR with combination organic vapor/HEPA cartridges)
- Inner gloves (Latex or Vinyl)
- Outer gloves (Nitrile or Neoprene)
- Boots (Safety boots with latex boot covers)
- Other

## 8.0 PERSONNEL DECONTAMINATION PROCEDURES

See Section 10 of the program health and safety plan for general procedures and guidance. Of the compounds being used for decontamination, methanol is considered potentially hazardous. Methanol is volatile and flammable. The PEL for methanol is 200 ppm. An STEL of 250 ppm for 15 minutes is allowed for methanol. Exposure of the skin to methanol can result in skin burns and/or skin absorption.

The PEL for methanol can be reached when the PID is reading 8 ppm. This is because the relative response factor of methanol is 0.04 when the PID is equipped with a standard 10.2 or 10.6 eV lamp and is calibrated with 100 ppm isobutylene. Therefore, air monitoring should be performed when decontaminating equipment with methanol. If a respirator is needed during such operations, appropriate cartridges should be used. Nitrile gloves and chemical goggles should be used.

Methanol will be in plastic bottle jackets during use in the field. These bottle jackets will be properly labeled, and during transport into the field will be cushioned inside a larger locked-lid plastic carrying container that is secured in the vehicle. All chemical wastes (waste methanol) generated during decontamination will be collected in an empty manufacturer's chemical bottle with a bottle jacket, labelled with contents, dated, and transported as described above. Call the point-of-contact at the Air Force Base for proper disposal procedures and transport to the hazardous materials storage area.

## **9.0 EMPLOYEE EXPOSURE MONITORING**

Employee exposure monitoring will be conducted on this site in accordance with Occupational Safety and Health Administration (OSHA) standards (29 CFR 1910) and the program health and safety plan.

## **10.0 EMERGENCY RESPONSE PLAN**

### **10.1 Safe Distances and Places of Refuge**

Prior to initiation of field activities, the field crew shall decide on safe distances to retreat to and select a place of refuge in the event of an emergency. This information shall be provided to all pilot test field personnel during weekly or daily site-specific safety briefings. All other guidelines established in the program health and safety plan for emergency planning, training, recognition, etc. shall be followed.

### **10.2 Emergency Information**

Listed below are the name and phone numbers for medical and emergency services for this project.

<b>Hospital</b>	305 Medical Squadron
<b>Address</b>	Matador Street and Morton Avenue
<b>Phone</b>	688-3303

#### **Description of the route to the hospital:**

From Building 735, go to Lightning Avenue at north side of the flightline, proceed north on Lightning Avenue for approximately 6 blocks to Matador Street. Turn left (west) on Matador Street and proceed west for 2½ blocks to 305 Medical Squadron.

#### **Other Emergency Numbers:**

Fire Department	688-3353
Security Police	688-3385
Ambulance	9118 (on base); 688-3202 (off base)

#### **Program Health and Safety Manager:**

Tim Mustard	work: (303) 831-8100
	home: (303) 450-9778

#### **Project Manager:**

Doug Downey	work: (303) 831-8100
	home: (303) 670-0512

## 11.0 REFERENCES

- Engineering-Science, Inc. 1993. *Bioventing Pilot Test Work Plan for Building 735 Pumphouse, Grissom AFB, Indiana*. Denver, Colorado.
- Engineering-Science, Inc. 1992. *Program Health and Safety Plan for the Bioventing Test Initiative*. Denver, Colorado.
- Hinchee, R.E., Ong, S.K., Miller, R.N., Downey, D.C., Frandt, R., 1992. *Test Plan and Technical Protocol for a Field Treatability Test for Bioventing*. January.

**PART II**  
**DRAFT INTERIM PILOT TEST RESULTS REPORT FOR**  
**BUILDING 735 PUMPHOUSE**  
**GRISSOM AFB, INDIANA**

**December 1993**

**Prepared for:**

**Air Force Center for Environmental Excellence**  
**Brooks AFB, Texas**

**and**

**305 SPTG/DEV**  
**Grissom AFB, Indiana**

**Prepared by:**

**Engineering-Science, Inc.**  
**1700 Broadway, Suite 900**  
**Denver, Colorado 80290**

## CONTENTS

### PART II - DRAFT INTERIM PILOT TEST RESULTS REPORT FOR BUILDING 735 PUMPHOUSE GRISSOM AFB, INDIANA

	<u>Page</u>
1.0 Pilot Test Design and Construction .....	II-1
1.1 Site Layout.....	II-1
1.2 Air Injection Vent Wells.....	II-3
1.3 Monitoring Points.....	II-3
1.4 Blower Unit.....	II-7
1.5 Exceptions to Test Protocol Document Procedures .....	II-7
2.0 Soil and Soil Gas Analytical Results .....	II-7
2.1 Soil Analytical Results .....	II-7
2.2 Soil Gas Analytical Results.....	II-9
3.0 Pilot Test Results .....	II-11
3.1 Air Permeability and Oxygen Influence .....	II-11
3.2 Dissolved Oxygen Results .....	II-11
3.3 <i>In Situ</i> Respiration Results.....	II-14
3.4 Potential Air Emissions .....	II-14
4.0 Conclusions and Basis for Phase 2 System Design .....	II-14
5.0 Phase 2 System Design, Operation, and Monitoring .....	II-15
5.1 Introduction.....	II-15
5.2 System Layout.....	II-15
5.3 System Design.....	II-16
5.4 System Operation .....	II-16
5.5 System Monitoring and Additional Testing .....	II-18
6.0 References .....	II-19
Appendix A Geologic Boring Logs and Chain-of-Custody Forms	
Appendix B O&M Checklist and Blower Specifications	

TABLES

<u>No.</u>	<u>Title</u>	<u>Page</u>
1.1	Well Construction Summary .....	II-5
2.1	Soil Analytical Results .....	II-10
3.1	Pressure Response .....	II-12
3.2	Dissolved Oxygen Monitoring Summary .....	II-13

FIGURES

<u>No.</u>	<u>Title</u>	<u>Page</u>
1.1	As-Built Site Layout .....	II-2
1.2	Typical As-Built Injection Vent Well Construction Detail .....	II-4
1.3	Typical As-Built Monitoring Point Construction Detail .....	II-6
2.1	Hydrogeologic Cross Section .....	II-8
5.1	As-Built Phase 2 Blower System Instrumentation Diagram for Air Injection .....	II-17

**PART II**

**DRAFT INTERIM PILOT TEST RESULTS REPORT**  
**BUILDING 735 PUMPHOUSE**  
**GRISSOM AFB, INDIANA**

Initial bioventing pilot tests were completed by Engineering-Science, Inc. (ES) at Building 735 Pumphouse, Grissom Air Force Base (AFB), Indiana, during the period of October 12 through 23, 1993. Additional system monitoring was performed by ES on December 10, 1993. The purpose of this Part II report is to describe the results of the initial Phase 1 and Phase 2 pilot tests and bioventing system installation at Building 735 and to make specific recommendations for extended testing to determine the long-term impact of bioventing on site contaminants. Although high water table conditions limited the success of initial bioventing tests, it appears that the installed bioventing system is beginning to dewater these soils and provide oxygen to stimulate both saturated and unsaturated zone biodegradation. Descriptions of the history, geology, and contamination at Building 735 are contained in Part I, the *Bioventing Pilot Test Work Plan*.

**1.0 PILOT TEST DESIGN AND CONSTRUCTION**

As described in Part I, pilot testing was performed in two phases. One air injection vent well (VW) and three vapor monitoring points (MPs) were installed on October 13 and 14, 1993 as part of the Phase 1 work. The first phase also included collecting background soil and soil gas data, and performing soil gas permeability testing. During Phase 2, seven additional VWs and two additional MPs were installed between October 18 and 20, 1993. Phase 2 work also included installing a blower system and buried air lines to the VWs, and system start-up. Drilling services were provided by Rhodes & Associates of Nicholasville, Kentucky, and well installation and soil sampling was directed by Mr. John Hall, the ES site manager. Electrical services for both sites were provided by Grissom AFB and Shideler Electric, Heating, and Cooling of Logansport, Indiana. The following sections describe the final design and installation of the bioventing system at Building 735.

**1.1 Site Layout**

Eight VWs, five MPs, and a blower unit were installed at the Building 735 site as shown on Figure 1.1. Boring logs for the MPs and VWs are included in Appendix A. The background MP (MPE) for this site was located adjacent to the existing upgradient groundwater monitoring well GMW-2. Existing 2-inch-diameter groundwater

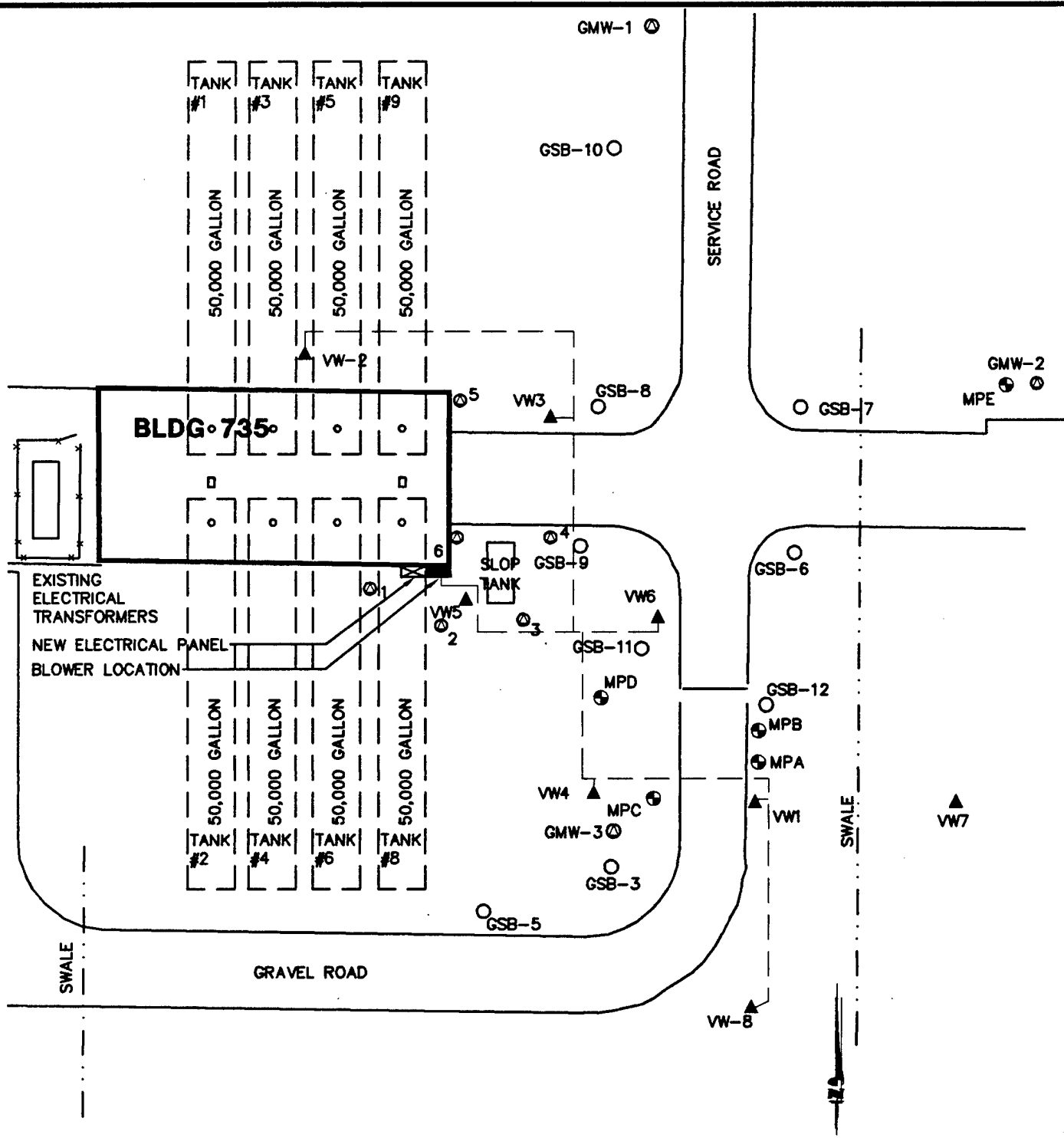

**LEGEND**

- ⊙ EXISTING MONITORING/PRODUCT RECOVERY WELL
- EXISTING SOIL BORING
- ▲ VENT/SPARGING WELL (AIR INJECTION) LOCATION
- ⊕ VAPOR MONITORING POINT LOCATION
- BURIED 2" PVC AIR LINE

**FIGURE 1.1  
AS-BUILT  
SITE LAYOUT**

**BUILDING 735  
GRISSOM AFB, INDIANA**

**ENGINEERING-SCIENCE, INC.  
Denver, Colorado**



monitoring wells and 8-inch-diameter product recovery wells will be utilized to monitor groundwater levels and dissolved oxygen (DO) concentrations.

## 1.2 Air Injection Vent Wells

The air injection VWs were installed following procedures described in the Air Force Center for Environmental Excellence (AFCEE) bioventing protocol document (Hinchee et al., 1992). The VWs were installed with the screened intervals extending a few feet below the groundwater surface to accommodate groundwater level fluctuations. The groundwater surface at this site ranged from the ground surface near Building 735 to 4.1 feet below ground surface (bgs) at VW8. The groundwater level at the time of VW installation was unseasonable high because of the unusually abundant rainfall that occurred during the summer and early fall.

Figure 1.2 shows typical construction details for the VWs, and Table 1.1 presents the well construction dimensions. The VWs were installed in contaminated soils with the screened intervals extending from approximately 4 feet bgs to depths ranging from 8.7 to 11.5 feet bgs.

The VWs were constructed using 4-inch-diameter, Schedule 40 polyvinyl chloride (PVC) casing, with intervals of 0.04-inch slotted PVC screen. The open boreholes were sealed with bentonite from the bottom of the well screen to total depth. The annular space between the well casing and borehole was filled with Number 6-9 silica sand from the bottom of the borehole to approximately 6 inches above the well screen. Granular bentonite or bentonite pellets were placed above the sand, hydrated in place, and overlaid with a concrete seal.

The tops of the VWs were completed with 4-inch-diameter flexible connectors through which were inserted 1-inch-diameter PVC air lines (Figure 1.2). Small stopcocks were installed near the top of each VW well casing to allow excess air from the blower to vent to the atmosphere when the entire screened interval is below the groundwater surface. A 1-inch ball valve was also installed in the air line to adjust air flow to the well. See Section 5.0 for a discussion of system operation. Surface completions were made with 18-inch-diameter flush-mounted manholes set in concrete.

## 1.3 Monitoring Points

The MP screens were installed at various depths as summarized in Table 1.1. The five MPs (MPA, MPB, MPC, MPD, and MPE) at this site were constructed as shown in Figure 1.3. MPA, MPB, MPC, and MPD were designed to monitor soil gas vapor chemistry and pressure response in areas of soil and groundwater contamination. The background MP (MPE), located approximately 160 feet east of Building 735, was designed to evaluate subsurface conditions outside the area of soil contamination.

Each MP was constructed using 6-inch sections of 1-inch-diameter PVC well screen with 0.25-inch Schedule 80 PVC riser pipes extending to the ground surface. At the top of each riser, a ball valve and a 3/16-inch hose barb was installed. The top of each MP was completed with an 8-inch-diameter flush-mounted metal well protector set in concrete. Thermocouples were installed at the 3- and 9-foot depths at MPA to measure soil temperature variations.

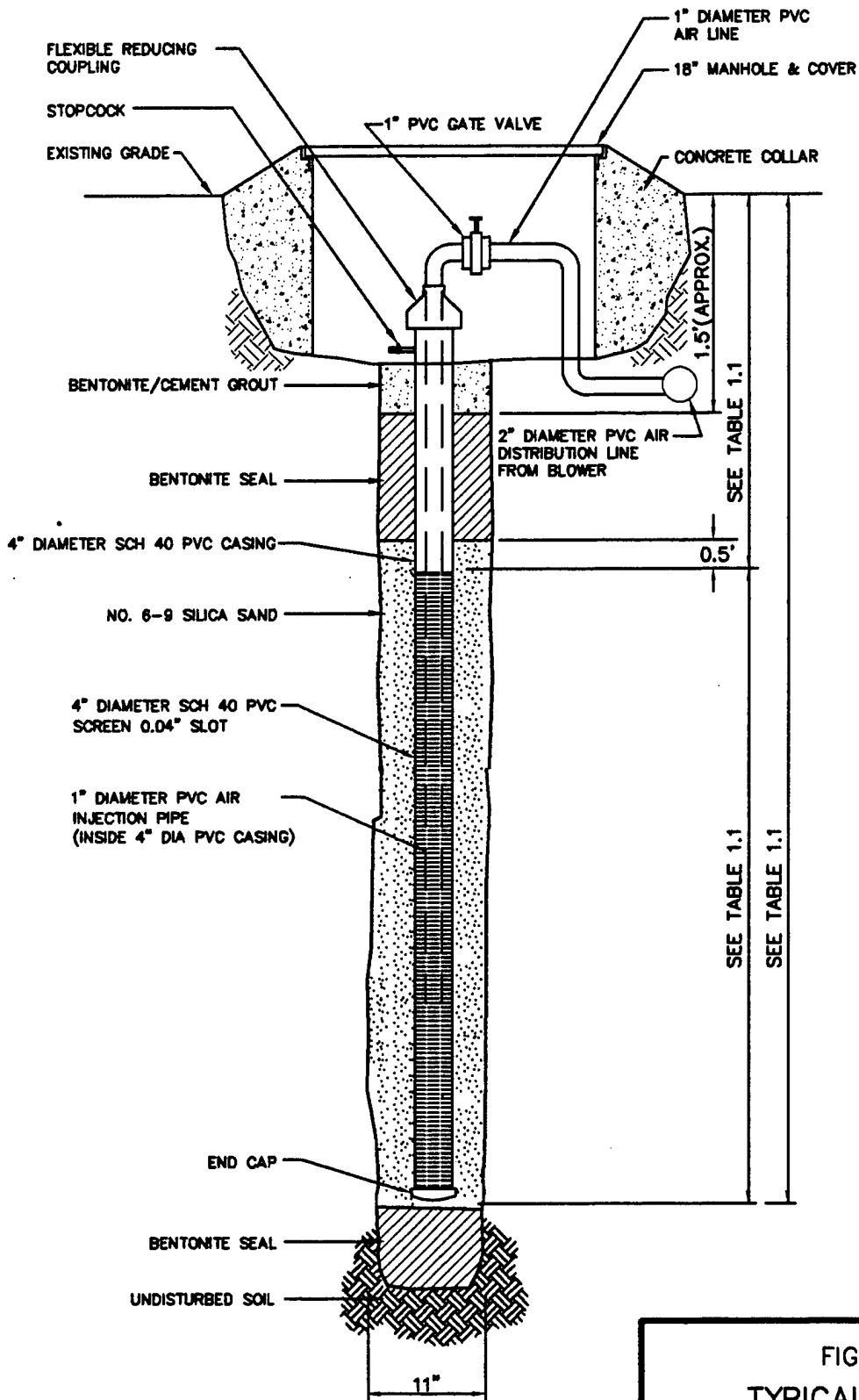

NOT TO SCALE

FIGURE 1.2  
 TYPICAL AS-BUILT  
 INJECTION/VENT WELL  
 CONSTRUCTION DETAIL

BUILDING 735  
 GRISSOM AFB, INDIANA  
 ENGINEERING-SCIENCE, INC.  
 Denver, Colorado



TABLE 1.1  
WELL CONSTRUCTION SUMMARY  
BUILDING 735 PUMPHOUSE  
GRISSOM AFB, INDIANA

Well ID <sup>a/</sup>	Date Completed	Total Borehole Depth (feet bgs) <sup>b/</sup>	Screened Interval (feet bgs)
VW1	10/13/93	9	3.7-8.7
VW2	10/18/93	14	4-12
VW3	10/18/93	12	4-11.5
VW4	10/18/93	14	4-11.5
VW5	10/18/93	13	4.5-11.5
VW6	10/18/93	14	4-11.5
VW7	10/19/93	15	4.5-11.5
VW8	10/19/93	15	4.5-11.5
MPA	10/14/93	10	3, 9
MPB	10/14/93	7	3, 6
MPC	10/14/93	5	3.5
MPD	10/20/93	10	4, 8
MPE	10/15/93	5	3

<sup>a/</sup> ID = identification  
<sup>b/</sup> bgs = below ground surface

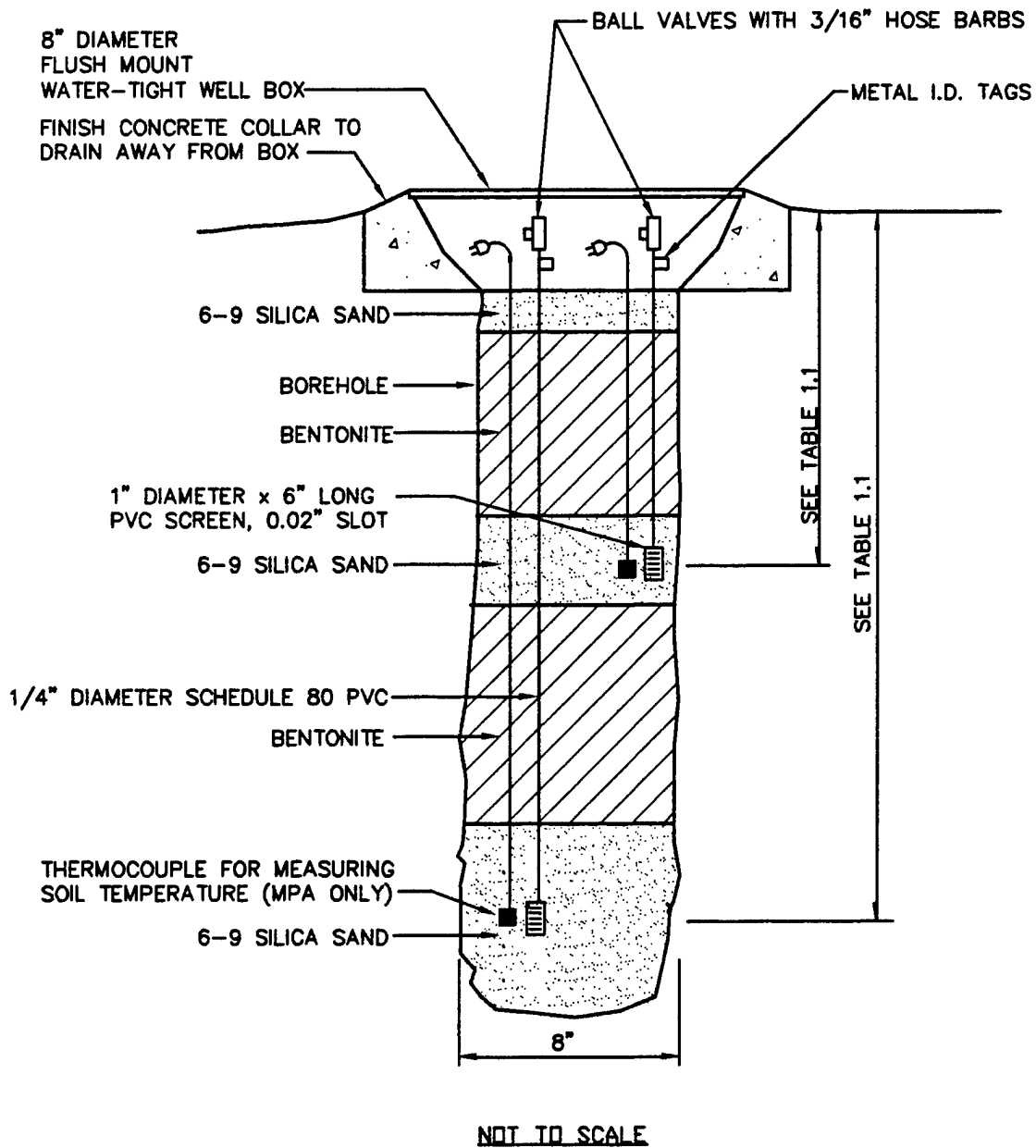

FIGURE 1.3  
TYPICAL AS-BUILT  
MONITORING POINT  
CONSTRUCTION DETAIL

BUILDING 735  
GRISSOM AFB, INDIANA

ENGINEERING-SCIENCE, INC.  
Denver, Colorado

ES

## 1.4 Blower Unit

A 3-horsepower Roots® positive-displacement blower unit was used for the Phase 1 pilot test. The configuration, instrumentation, and specifications for the initial pilot test and extended pilot test units are shown in Part I, Figure 3.5. The initial pilot test blower was energized by 208-volt, single-phase, 20-amp line power from the electrical panel located near the southeast corner of Building 735 that was installed by Grissom AFB. Power was brought to the panel from an existing panel inside Building 735.

## 1.5 Exceptions To Test Protocol Document Procedures

Procedures described in the protocol document (Hinchee et al., 1992) were generally used to complete treatability tests at this site. However, because of the high groundwater levels and expanded scope of work compared to the typical pilot test, the following procedures deviated from those described in the protocol document:

- Respiration tests were not performed because the low permeability soils prevented collecting representative soil gas samples;
- Only two soil gas samples were collected in SUMMA® canisters for laboratory analysis because of the difficulty encountered collecting representative samples;
- A full-scale bioventing system was installed which included drilling additional soil borings to delineate the area of soil contamination and installing seven additional VWs and two additional MPs;
- The VW construction included a 1-inch-diameter air injection pipe to inject air into the groundwater during times of high groundwater levels;
- Additional soil samples were collected and analyzed for benzene, toluene, ethylbenzene, and xylenes (BTEX) and total recoverable petroleum hydrocarbons (TRPH); and
- Groundwater DO concentrations were measured at selected locations, and will be monitored throughout the period of extended testing.

## 2.0 SOIL AND SOIL GAS ANALYTICAL RESULTS

### 2.1 Soil Analytical Results

Soils at this site consist of a mixture of roughly equal parts of sand, silt, and clay, with occasional gravelly layers. Figure 2.1 is a typical hydrogeologic section through the site showing lithology and the locations of the MP and VW screened intervals relative to the groundwater surface at the time of well installation.

Hydrocarbon contamination at this site was generally encountered from near the ground surface to depths ranging from approximately 8 to 11 feet bgs. No contamination was detected below 11 feet bgs. Contaminated soils were identified based on visual appearance, odor, and soil headspace volatile organic compound (VOC) field screening results. Contaminated soils were encountered in all VW and MP boreholes except for background MPE and VW7. Only very slight contamination was detected in the VW8 borehole. Contaminated soils had a strong hydrocarbon odor and, in most cases, were stained.

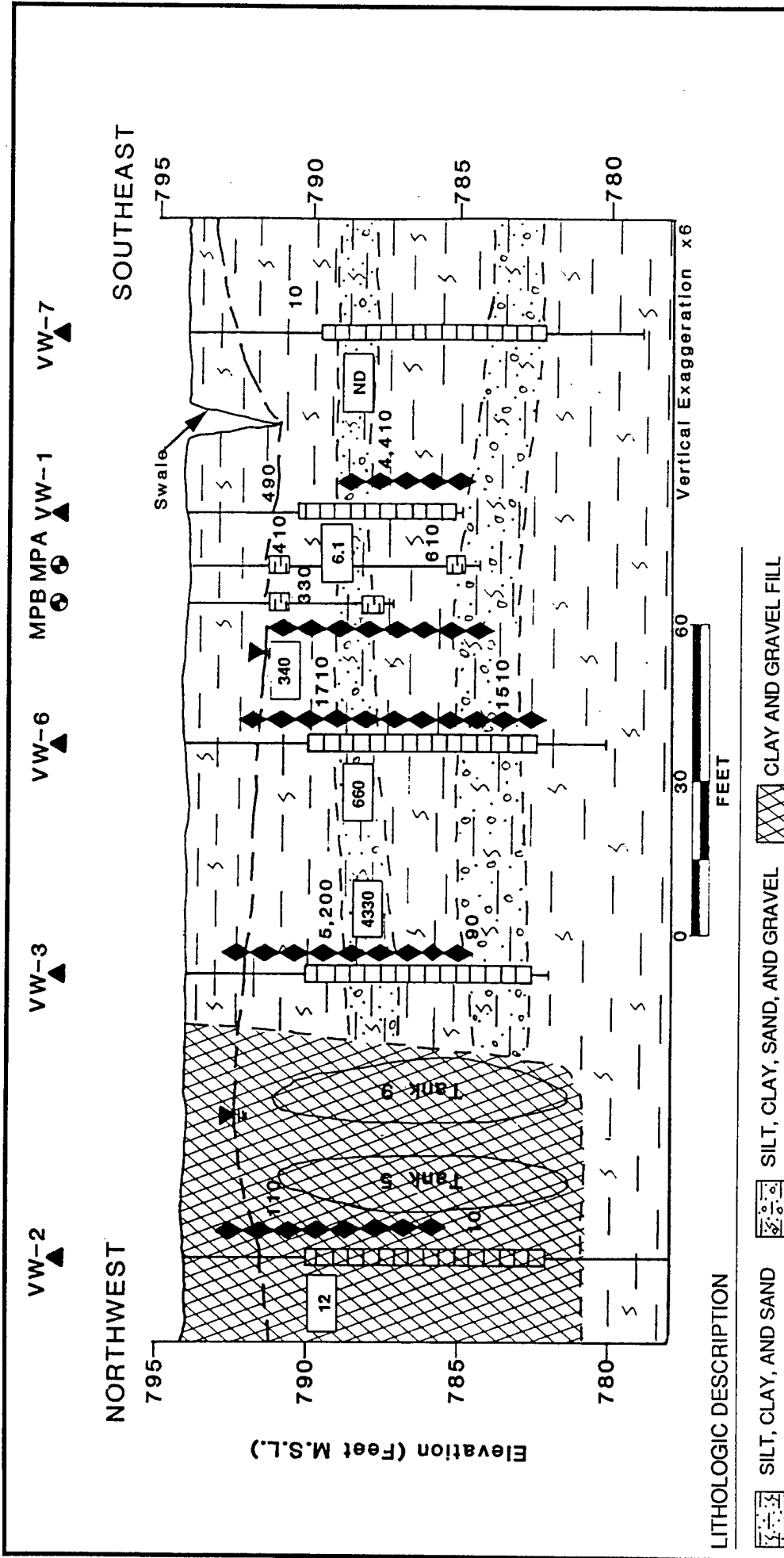

**FIGURE 2.1**

**HYDROGEOLOGIC CROSS SECTION**  
**BLDG 735**

GRISSOM AFB, INDIANA

**ENGINEERING-SCIENCE, INC.**  
 Denver, Colorado

**LITHOLOGIC DESCRIPTION**

SILT, CLAY, SAND, AND GRAVEL    
 CLAY AND GRAVEL FILL

**LEGEND**

MONITORING WELL    
 STATIC GROUNDWATER ELEVATION  
 SOIL BOREHOLE    
 GEOLOGIC CONTACT, DASHED WHERE INFERRED  
 FIELD SCREENING RESULTS FOR TOTAL VOLATILE HYDROCARBONS (PPMV)  
 LABORATORY RESULTS FOR SOIL; TOTAL VOLATILE HYDROCARBONS (mg/kg)  
 FUEL ODOR DETECTED DURING DRILLING  
 MONITORING POINT  
 SCREENED WELL INTERVAL  
 M.S.L. MEAN SEA LEVEL

Soil samples for laboratory analysis were collected from split-spoon samplers with 2.5-inch-diameter brass liners. Soil samples were shipped via Federal Express® to the Pace, Inc. laboratory in Novato, California, for chemical and physical analysis. Soil sample headspace was screened for VOCs using a total volatile hydrocarbon (TVH) analyzer to determine the presence of contamination and to select soil samples for laboratory analysis. Soil samples for laboratory analysis were collected from most VW and MP boreholes. A background soil sample was collected from the background MP borehole. Soil samples were analyzed for TRPH, BTEX, grain size, moisture content, total Kjeldahl nitrogen (TKN), iron, and alkalinity. The background soil sample was analyzed only for TKN. Sampling locations and depths, and a summary of the laboratory analytical results are summarized in Table 2.1.

## 2.2 Soil Gas Analytical Results

Prior to initiating any air injection during Phase 1, all MPs were purged. Many of the MPs were saturated and soil gas samples could not be collected. Where possible, initial oxygen, carbon dioxide, and TVH concentrations were measured using portable gas analyzers, as described in the technical protocol document (Hinchee et al., 1992).

Soil gas sampling efforts were severely hampered by the very moist, low-permeability soils. Low permeability is the result of small soil grain size (approximately 45 to 50 percent silt and clay size) and high moisture content. Because of the low permeability, purging may not have been sufficient to remove all of the air introduced during MP construction. Efforts to withdraw soil gas and purge the MPs resulted in relatively high vacuums and little soil gas flow into the MPs.

Incomplete purging was indicated by the high oxygen concentrations measured in the extracted soil gas samples. Typically, soil gas from such highly contaminated soils is deficient in oxygen due to biological activity. Another indication of low rates of soil gas flow to the MPs was that residual vacuum that was the result of initial purging remained in VW1 and the MPs for periods of time ranging from approximately 1 hour to more than 1 day. Because of the low soil gas permeability, and resulting difficulty collecting soil gas samples, the few samples collected are presumed not to be representative of the *in situ* soil gas. Additional soil gas sampling will be completed when high ground water levels subside. However, baseline groundwater DO measurements were taken at selected locations, and these results will be used to help evaluate Phase 2 system performance. DO results are discussed in Section 3.2.

Soil gas samples were collected by extracting soil gas from VW1 and from a depth of 3 feet from MPA. Because of the very low permeability of the soil to soil gas and the high soil moisture content, it was not possible to collect soil gas samples from MPB or MPC. Soil gas samples were shipped via Federal Express® to Air Toxics, Inc. in Folsom, California, for TVH and BTEX analysis.

Both soil gas samples had relatively high levels of BTEX compounds, ranging from approximately 1 to 36 parts per million, volume per volume (ppmv). Because of the likelihood that these samples were diluted with clean air, the actual soil gas BTEX concentrations are probably higher than these values.

TABLE 2.1

SOIL ANALYTICAL RESULTS  
 BUILDING 735 PUMPHOUSE  
 GRISSOM AFB, INDIANA

Analyte (units)	Sample Location-Depth (feet below ground surface)									
	VW-5	VW2-4	VW3-6	VW6-6	VW7-6	VW8-6	MPA-4	MPB-3	MPE-3	
<b>Soil Hydrocarbons</b>										
TRPH (mg/kg) <sup>a/</sup>	6.1	12	4330	660	ND <sup>b/</sup>	8.2	190	340	NS <sup>c/</sup>	
Benzene (mg/kg)	0.016	0.005	28	5.2	1.3	0.0065	ND	0.44	NS	
Toluene (mg/kg)	0.0011	0.0082	74	6.8	4.3	0.0054	0.83	1.2	NS	
Ethylbenzene (mg/kg)	0.039	0.053	47	18	1.6	0.0078	1.8	2.2	NS	
Xylenes (mg/kg)	0.11	0.052	200	68	7.6	0.033	5	6.4	NS	
<b>Soil Inorganics</b>										
Iron (mg/kg)	16400	NS	NS	NS	NS	NS	13900	14800	NS	
Alkalinity (mg/kg as CaCO <sub>3</sub> ) <sup>d/</sup>	690	NS	NS	NS	NS	NS	540	1950	NS	
pH (pH units)	8	NS	NS	NS	NS	NS	8	8	NS	
TKN (mg/kg) <sup>e/</sup>	1300	NS	NS	NS	NS	NS	260	200	68	
Phosphates (mg/kg)	340	NS	NS	NS	NS	NS	340	210	NS	
<b>Soil Physical Parameters</b>										
Moisture (% by weight)	14	15	11	11	13	6.1	14	10	NS	
Gravel (%)	0.9	NS	NS	NS	NS	NS	7.2	1.4	NS	
Sand (%)	37.4	NS	NS	NS	NS	NS	42.9	52.2	NS	
Silt (%)	38.0	NS	NS	NS	NS	NS	33.9	30.2	NS	
Clay (%)	23.7	NS	NS	NS	NS	NS	16	16.3	NS	

<sup>a/</sup> TRPH = total recoverable petroleum hydrocarbons; mg/kg = milligrams per kilogram

<sup>b/</sup> ND = not detected

<sup>c/</sup> NS = not sampled

<sup>d/</sup> CaCO<sub>3</sub> = calcium carbonate

<sup>e/</sup> TKN = total Kjeldahl nitrogen

### **3.0 PILOT TEST RESULTS**

#### **3.1 Air Permeability and Oxygen Influence**

An air permeability test was conducted according to protocol document procedures (Hinchee et al., 1992). The objective of this test was to determine soil permeability to air flow, and the radius of pressure and oxygen influence resulting from injecting air at the VW. Air was injected into VW1 for 16 hours at a rate of less than 2 standard cubic feet per minute (scfm) and an average pressure of approximately 4 pounds per square inch (psi). Initially, air flow was confined to the subsurface soils, but during the night the flow began short-circuiting to the atmosphere through the bentonite seal as the result of relatively high injection pressures. Pressure response was not detected at any MPs and it was not possible to measure changes in soil gas oxygen because of the difficulty collecting representative soil gas samples.

Because of the saturated and near-saturated condition of the soils, resulting in the collection of insufficient data, it was not possible to calculate soil permeability or determine the effective radius of pressure and oxygen influence during Phase 1. However, based on ES's experience with other sites with similar soil conditions, a radius of pressure and oxygen influence in the range of 25 to 35 feet from the VW would be expected for this site assuming less saturated soil conditions.

Significant pressure response was measured at the shallow depths at MPs A, B, C, and D on December 10, 1993 following approximately 7 weeks of Phase 2 system operation. Pressure response measurements are summarized in Table 3.1. The pressure response measured at the MPs confirm that well spacing used for the Phase 2 system installation is sufficient to influence the entire area of soils in which TRPH contamination exceeded the action level of 100 mg/kg. A pressure response of 10 inches of water was measured at MPD, which is located 22 feet from the nearest VW. The depth to groundwater was less than 4.5 feet bgs when these pressure measurements were taken. As the depth to groundwater increases during the summer months, both the pressure response and radius of oxygen influence are expected to increase.

Direct measurement of the radius of oxygen influence has not been made because of the difficulty obtaining representative soil gas samples during Phase 1 testing. However, based on measured pressure response, which is an indicator of long-term oxygen transport, it is anticipated that the radius of influence for the long-term Phase 2 bioventing system will exceed 25 feet in unsaturated soils. Results from continued system monitoring will be used to confirm the actual radius of oxygen influence.

#### **3.2 Dissolved Oxygen Results**

Baseline DO concentrations were measured in existing groundwater monitoring wells GMW-2 and GMW-3, product recovery wells 1, 2, 3, and 4, and all VWs (Figure 1.1) on October 22, 1993. DO concentrations were measured again on December 10, 1993 after the Phase 2 system had been operating for approximately 7 weeks.

Outside the areas of soil and groundwater contamination, initial groundwater DO concentrations were greater than 7 milligrams per liter (mg/L), which is typical for uncontaminated shallow groundwater. In contrast, DO was depleted (less than 1 mg/L) in the groundwater at most locations within the area of soil contamination. Table 3.2

TABLE 3.1  
 PRESSURE RESPONSE <sup>a/</sup>  
 BUILDING 735 PUMPHOUSE  
 GRISSOM AFB, INDIANA

Location	Depth (feet)	Distance from Nearest VW (feet)	Pressure (Inches of water)
MPA	3	9.5	2.0
MPA	9	9.5	<0.10
MPB	3	16.5	4.2
MPB	6	16.5	1.4
MPC	3.5	13.5	26
MPD	4	22	10
MPD	8	22	<0.10

<sup>a/</sup> Pressures measured on 12/10/93. Injection pressure approximately 80 inches of water.

TABLE 3.2  
 DISSOLVED OXYGEN MONITORING SUMMARY  
 BUILDING 735 PUMPHOUSE  
 GRISSOM AFB, INDIANA

Location	Initial D.O. (10/22/93) (mg/L) <sup>a/</sup>	D.O. (12/10/93) (mg/L)
PRW-1 <sup>b/</sup>	7.20	9.12
PRW-2	0.10	0.67
PRW-3	0.05	0.91
PRW-4	0.0	9.80
PRW-5	NA	0.43
GMW-2 <sup>c/</sup>	0.00	0.32
GMW-3	0.09	0.36

<sup>a/</sup> mg/L = Milligrams per liter  
<sup>b/</sup> PRW = Product recovery well  
<sup>c/</sup> GMW = Groundwater monitoring well

summarizes the initial and 7-week DO concentrations at selected locations. Depleted DO indicates that microbial fuel biodegradation is occurring in areas with soil contamination, and that the additional oxygen provided by the bioventing system will increase fuel biodegradation rates.

Following 7 weeks of system operation, DO concentrations were measured to evaluate the effect of system operation on the groundwater DO concentrations. As shown on Table 3.2, increased DO concentrations were measured in the groundwater at all sampling locations. DO concentration increases of 1.9 mg/L and 9.8 mg/L were measured at product recovery wells (PRW)-1 and -4, respectively, while increases of less than 1 mg/L were measured at PRW-2 and -3. These results indicate that the Phase 2 system has been successful introducing oxygen into the groundwater in the area of soil contamination. Because groundwater DO concentrations were initially depleted (ranging from 0.0 to 0.10 mg/L), the increased DO concentrations should increase the rate of fuel biodegradation in the saturated zone. Continued DO monitoring will be performed to confirm these preliminary results.

### **3.3 *In Situ* Respiration Rates**

The objective of an *in situ* respiration test is to measure the rate of biological activity based on oxygen uptake and calculate fuel biological degradation rates. However, the *in situ* respiration test was not performed during Phase 1 because it was not possible to inject sufficient quantities of air into the low-permeability soils and due to the difficulty collecting representative soil gas samples for analysis. ES will attempt to collect and analyze soil gas samples and perform respiration tests in the future when water levels drop sufficiently (late spring or summer 1994).

Although an *in situ* respiration test was not performed, low concentrations of DO measured in shallow groundwater in areas with soil contamination, in contrast to high DO concentrations outside the contaminated area (Table 3.2), indicate that biological activity and biological fuel degradation is occurring in areas with soil contamination.

### **3.4 Potential Air Emissions**

The long-term potential for air emissions from full-scale bioventing operations at this site is low because of the low injection rates and the predominantly horizontal air flow through the soils. The stratified nature of the subsurface soils (Figure 2.1) favors horizontal over vertical air flow through the soil, as indicated by significant pressure response measured more than 20 feet from a VW through a less than 4.5-foot-thick zone of unsaturated soils. Emissions should be minimal because accumulated vapors will move slowly outward from the air injection points and will be biodegraded as they move horizontally through the soil. An existing air exhaust system in the fuel pumping facility, (Building 735) is designed to remove any fuel vapors that might accumulate inside the building [Twin City Testing (TCT), 1992].

## **4.0 CONCLUSIONS AND BASIS FOR PHASE 2 SYSTEM DESIGN**

Initial bioventing tests at this site indicate that oxygen has been depleted in the contaminated soils and groundwater, and that air injection would be an effective method of increasing aerobic fuel biodegradation. AFCEE has recommended that air

injection continue at this site to determine the long-term radius of oxygen influence and the effect of time, available nutrients, and changing temperatures on fuel biodegradation rates.

The long-term radius of influence for each VW is conservatively estimated to be 25 feet, assuming unsaturated conditions to a depth of about 5 to 7 feet bgs. This estimate is based on ES's experience at sites with similar soil types and depths of contamination. System monitoring after 7 weeks of operation confirmed that the radius of pressure influence exceeds 22 feet. The combined area of pressure influence from the seven VWs encompasses the area of soil contamination exceeding the TRPH action level of 100 mg/kg.

Because the saturated zone is fairly shallow for much of the year, and the top of the VW well screens will be submerged during these times, the full-scale system was designed to oxygenate the groundwater in the vicinity of the VWs during times of high groundwater levels. As the groundwater levels drop, exposing the VW screens, the system will automatically divert air flow into the unsaturated soils. To supply air and oxygen to both the groundwater and unsaturated soils, 1-inch-diameter air sparging pipes, extending to a depth of approximately 7.5 feet bgs, were installed within the 4-inch-diameter VW casings. Preliminary results of system monitoring indicate that the system is oxygenating the groundwater in areas of soil contamination.

The blower system for the Phase 2 system is capable of supplying air at 160 scfm at an injection pressure of 3 psi (approximately 82 inches of water). The blower system is described in Section 5.3.

Physical descriptions of the Phase 2 system and descriptions of the system operation and monitoring are presented in the following sections.

## **5.0 PHASE 2 SYSTEM DESIGN, OPERATION, AND MONITORING**

### **5.1 Introduction**

The objective of Phase 2 is to remediate the soils at the site utilizing enhanced microbial fuel degradation. The microbial biodegradation of fuel hydrocarbons will be increased by introducing oxygen to the subsurface materials using forced air as the oxygen source. A detailed discussion of this process is presented in the protocol document (Hinchee et al., 1992).

The system installed at Building 735 was designed primarily to remediate the unsaturated soils utilizing bioventing technology. However, because a large part of the contaminated soil volume is beneath the groundwater surface for much of the year (typically the winter and spring seasons), a modified air sparging system was incorporated into the design with the intention of remediating saturated soils and groundwater during times of high groundwater levels.

### **5.2 System Layout**

The system installed at the Building 735 site is a combined bioventing and air sparging system. The layout of the system is shown in Figure 1.1. The system consists of 7 VWs connected to a 5.5-horse-power (hp) blower system via underground PVC and galvanize iron pipes. Multiple-depth MPs and existing groundwater

monitoring wells will be used to monitor the effectiveness of the system in supplying oxygen to the soil gas and groundwater.

### 5.3 System Design

The system installed at the site for extended system operation includes a blower system, air distribution lines, VWs, and MPs. VW and MP construction was discussed in Sections 1.2 and 1.3, respectively.

The blower system consists of a Gast® Model R6P155Q-50 regenerative blower unit, flow control valves, temperature and pressure indicators, and air velocity measuring ports. A schematic of this blower system is shown on Figure 5.1. The blower is powered by a direct-drive, 5.5-hp, explosion-proof, 208-volt, single-phase electric motor rated at 19.8 full-load amps. This unit was hard-wired to an on/off switch and starter inside the blower enclosure, then wired to the newly installed panel located on the outside wall of Building 735. All electrical components and connections between the blower and electrical panel are explosion-proof and rated for use in hazardous locations.

The blower system for the Phase 2 system is capable of supplying air at 160 scfm at an injection pressure of 3 psi (approximately 82 inches of water). At 3 psi, the system is capable of injecting air into the groundwater to a depth of approximately 7.5 feet below the water surface. This injection pressure will also tend to depress the water surface in the vicinity of the VWs, exposing additional well screen and increasing the thickness of the unsaturated zone. The extended pilot test blower was configured to inject air at a rate of approximately 48 scfm at a pressure of 3.0 psi. Air flow to the VWs will increase as water levels drop, exposing additional VW screen.

### 5.4 System Operation

The system is designed to deliver air simultaneously to the unsaturated soils and to the groundwater via the VWs. Air is supplied to each VW through the 1-inch-diameter PVC air injection pipe (Figure 1.2). When the groundwater level in the VW is above the bottom of the air injection pipe, the air first bubbles through the water (increasing the DO concentration), then exits through the well screen into the unsaturated soils. When the water level in the VW is near or above the top of the screen, the air is vented from the VW through a small-diameter stopcock. Venting allows air to continue bubbling through the water even though there is little or no flow through the well screen. The stopcock is sized to allow for sufficient air flow through the air injection pipe to saturate the groundwater in the VW with oxygen while partially restricting the flow to maintain approximately 3 psi air pressure within the VW casing.

Maintaining pressure within the VW serves two purposes: it will locally depress the groundwater surface, and will provide a pressure gradient to force air into the unsaturated soil. A pressure of 3 psi (approximately 82 inches of water) will theoretically depress the groundwater surface 82 inches. The actual groundwater depression will be determined by periodically monitoring groundwater levels in both the VWs, and the existing groundwater monitoring and product recovery wells. Depressing the groundwater surface will expose a thicker interval of unsaturated soils that can be remediated with bioventing.

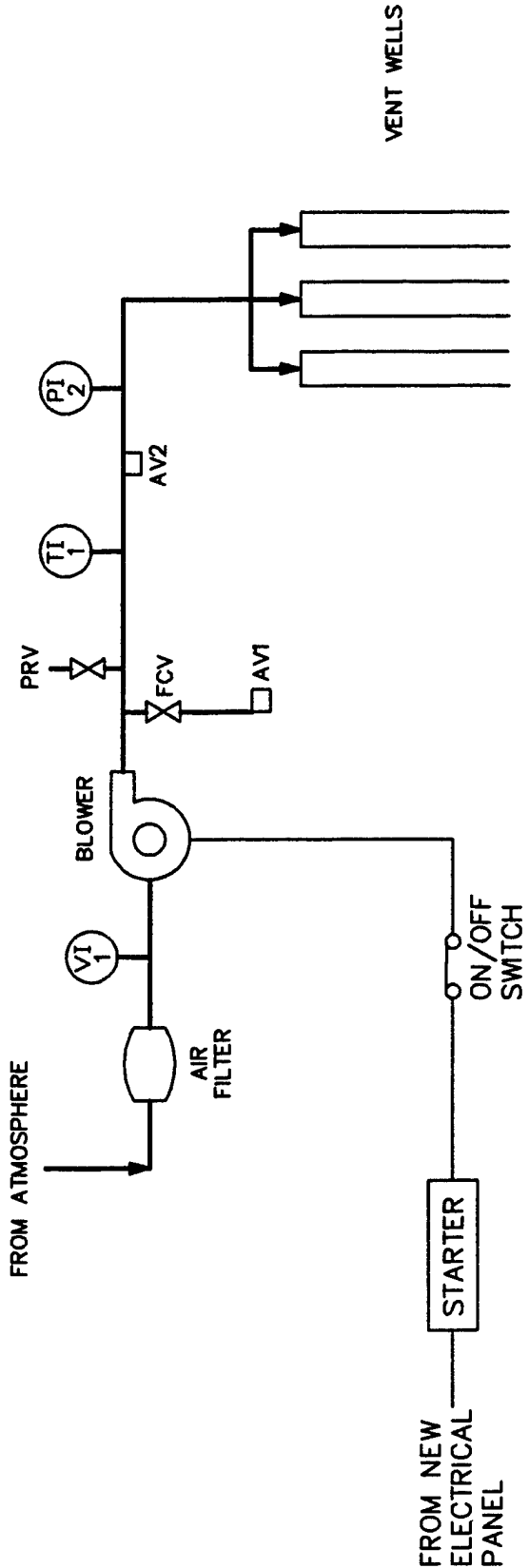

LEGEND

- (VI 1) VACUUM INDICATOR
- (PI 1) PRESSURE INDICATOR
- (TI 1) TEMPERATURE INDICATOR
- FCV FLOW CONTROL VALVE
- PRV PRESSURE RELIEF VALVE
- AV1 AIR VELOCITY MONITORING PORT

FIGURE 5.1

**AS-BUILT PHASE 2 BLOWER  
SYSTEM INSTRUMENTATION  
DIAGRAM FOR AIR INJECTION  
BUILDING 735**

GRISSOM AFB, INDIANA  
ENGINEERING-SCIENCE, INC.  
Denver, Colorado



The pressure in the VWs will force air into the surrounding unsaturated soils as the water level drops or as a result of pressure-induced groundwater level depression. As the length of screen above the water level increases, air flow to the VW and into the soil will increase proportionately.

The blower system is designed with sufficient air flow capacity to automatically increase the flow rate to the VWs as more screen is exposed by falling groundwater levels. A manual bleed valve and an automatic pressure relief valve (PRV) adjust the air flow to the VWs while maintaining a constant pressure of approximately 3 psi. As the flow to the VWs increases, because more VW screen is exposed, the system automatically compensates by reducing the flow through the PRV. These two flow control valves will periodically be adjusted by ES personnel to ensure optimum air flow to the VWs.

The in-line flow control valves installed before each VW can be used to selectively balance the air flow between VWs if necessary. These valves will typically remain fully open.

### **5.5 System Monitoring and Additional Testing**

The remediation system installed at Building 735 was designed for minimum monitoring and maintenance. ES requests that Grissom AFB personnel perform weekly blower system monitoring and minor maintenance. Prior to departing from the site, ES engineers provided an operations and maintenance (O&M) briefing checklist and blower maintenance manual to base personnel. A copy of the checklist is provided in Appendix B. Additional soil and soil gas samples will also be collected for laboratory analysis to determine the degree of remediation achieved during the first year of system operation.

The system will also be monitored by ES approximately every 2 months to determine if the goal of enhancing microbial fuel biodegradation, by introducing oxygen to the soil gas and groundwater, is being met. The effectiveness of the system for introducing oxygen to the soil gas will be evaluated by monitoring oxygen and TVH concentrations, and pressure response at the MPs. Additionally, the effectiveness of the system for introducing oxygen to the groundwater will be evaluated by monitoring the DO concentrations in the existing groundwater monitoring wells PRWS. DO concentrations should continue to slowly increase if the system is functioning as intended.

ES will return to the site to perform respiration tests at selected VWs and MPs to determine respiration and fuel biodegradation rates. It is anticipated that the additional respiration tests will be performed during late spring or summer 1995, after the soil moisture decreases sufficiently to successfully perform these tests. The exact schedule for additional testing and soil sampling will be determined based on measured groundwater levels.

Continued monitoring and additional testing will determine the long-term radius of oxygen influence in both the groundwater and soil gas, and the effects of time, available nutrients, and changing temperature on fuel biodegradation rates.

## 6.0 REFERENCES

- Hinchee, R.E., S.K. Ong., R.N. Miller, D.C. Downey, and R. Frandt. 1992. *Test Plan and Technical Protocol for a Field Treatability Test for Bioventing*. Prepared for USAF Center for Environmental Excellence. May.
- Twin City Testing Corporation, 1992. *Final Project Final Report. Remedial Action Investigation, Leaking Underground Storage Tanks, Grissom Air Force Base, IN*. March.

**APPENDIX A  
GEOLOGIC BORING LOGS AND  
CHAIN-OF-CUSTODY FORMS**

# GEOLOGIC BORING LOG

BORING NO. VW1      CONTRACTOR: Rhodes & Assoc      DATE SPUD: 10/13 1413  
 CLIENT: GRISSON      RIG TYPE: \_\_\_\_\_      DATE CMLP: 10/13 1500  
 JOB NO.: DE268-31-04      DRLG METHOD: HSA      ELEVATION: ~794  
 LOCATION: Blg 735      BORING DIA.: 11" 0      TEMP.: ~50°F  
 GEOLOGIST: JFH      DRLG FLUID: \_\_\_\_\_      WEATHER: partly cloudy  
 COMMENTS: \_\_\_\_\_

Elev. (ft.)	Depth (ft.)	Pro-file	US CS	Geologic Description	Samples		Sample Type	Penet. Res.	Remarks TIP = Bkgrnd/Reading (ppm)
					No.	Depth (ft)			
	1		ML-OL	Silt, clayey tan soil dk brn v. moist sm sand no odor					
			CL-ML	Silt w/ sm sand & clay, dk brn moist no odor / shgray stains					
	5		CL-ML	CLAY, sm sand, gravel & G' > 2" φ strong odor, gr. stain v. moist + v. hard drilling @ 6.5'	3-5		D	8, 10, 12	1430 TVH 580 all, dk s. lo
			CL-ML	Base of cont. ~ 8-8 1/2'	5-7		D	5, 23, 20	TVH 4,500
	10		CL-ML	CLAY & GRAVEL > 2" > 4"			D	30, 50	TO = 9'
	15								
	20								
	25								
	30								

sl - slight	v - very	f - fine	<b>SAMPLE TYPE</b>	
tr - trace	lt - light	m - medium	D - DRIVE	C Core recovery
sm - some	dk - dark	c - coarse	C - CORE	
& - and	bf - buff	BH - Bore Hole	G - GRAB	Core lost
@ - at	brn - brown	SAA - Same As Above		
w - with	blk - black			

Water level drilled

# GEOLOGIC BORING LOG

BORING NO. VW 2      CONTRACTOR: Rhodes      DATE SPUD: 10/15/93 10:10  
 CLIENT: \_\_\_\_\_      RIG TYPE: CME      DATE CMPL: 10/15/93  
 JOB NO.: DE268-31.04      DRLG METHOD: HSA      ELEVATION: 794  
 LOCATION: Bldg 735      BORING DIA.: 11"      TEMP.: 45-55°F  
 GEOLOGIST: JFH      DRLG FLUID: \_\_\_\_\_      WEATHER: cloudy  
 COMMENTS: E silt Pump house

Elev. (ft.)	Depth (ft.)	Pro-file	US CS	Geologic Description	Samples		Sample Type	Penet. Res.	Remarks TIP = Bkgrnd/Reading (ppm)
					No.	Depth (ft)			
	1		Fill	GRAVEL & CLAY Fill v. moist					
			CL-	CLAY & SILT, gray, fine odor					
			ML-	sm-to "aw" GRAVEL					
			GC						
	5								
				CLAY & SILT Gray, v. moist			D	6644	no recovery
				sl. odor - less odor w/ depth					
				~8.5' GRAVEL					
	10								
				CLAY, sm silt, sand, gravel v. moist,			D	2325	TUH 100
				no-sl odor gray					
	15								
				ROCKS/GRAVEL v. hard drilling					
				14' auger refusal					TD=14'
	20								
	25								
	30								

sl - slight	v - very	f - fine	<b>SAMPLE TYPE</b>	
tr - trace	lt - light	m - medium	D - DRIVE	C Core recovery
sm - some	dk - dark	c - coarse	C - CORE	
& - and	bf - buff	BH - Bore Hole	G - GRAB	Core lost
@ - at	brn - brown	SAA - Same As Above		
w - with	blk - black			

Water level drilled

# GEOLOGIC BORING LOG

BORING NO. <u>1W3</u>	CONTRACTOR: <u>R. Hodges</u>	DATE SPUD: <u>10/18/93 1245</u>
CLIENT: <u>Grissom AFB</u>	RIG TYPE: <u>CME</u>	DATE CMPL: <u>10/18/93 1335</u>
JOB NO.: <u>DE268-31-04</u>	DRLG METHOD: <u>HSA</u>	ELEVATION: <u>~794</u>
LOCATION: <u>Rd 735</u>	BORING DIA.: <u>11"</u>	TEMP.: <u>~50°F</u>
GEOLOGIST: <u>JFH</u>	DRLG FLUID: <u>---</u>	WEATHER: <u>cloudy</u>

COMMENTS:

Elev. (ft.)	Depth (ft.)	Pro-file	US CS	Geologic Description	Samples		Sample Type	Penet. Res.	Remarks TIP = Bkgnd/Reading (ppm)
					No.	Depth (ft)			
	1			GRAVEL FILL					
			CC-ML	CLAY & SILT, tan sand gray v. moist - wet, strgy odor			G		
	5			SAA w/ sm-tr gravel			D	4/52	13:05 TWT = 5,200
			ML-GC	hard drilling - gravel brn/gray					
			CC-ML	not as wet - softer @ 7-8'					
	10			CLAY & SILT, moist, gray, silty odor					
			ML-GC	SILT & CLAY, sm sand & gravel (+ gray sl moist no odor - water @ ~10.5' - muddy cuttings			D	4/23 > 50	TWT = 18' TD = 12
	15								
	20								
	25								
	30								

sl - slight	v - very	f - fine	<b>SAMPLE TYPE</b>	
tr - trace	lt - light	m - medium	D - DRIVE	C - Core recovery
sm - some	dk - dark	c - coarse	C - CORE	
& - and	bf - buff	BH - Bore Hole	G - GRAB	Core lost
@ - at	brn - brown	SAA - Same As Above		
w - with	blk - black			Water level drilled

# GEOLOGIC BORING LOG

BORING NO. VW 4 - CONTRACTOR: Rhodes DATE SPUD: 10/18/43 1410  
 CLIENT: Grissom AFB RIG TYPE: CME DATE CMPL: 10/18/43  
 JOB NO.: DE208-31.04 DRLG METHOD: HSA ELEVATION: 794  
 LOCATION: Blg 735 BORING DIA.: 11" TEMP.: 60's °F  
 GEOLOGIST: JFH DRLG FLUID: --- WEATHER: S Wind, sunny  
 COMMENTS: near CMW3

Elev. (ft.)	Depth (ft.)	Pro-file	US CS	Geologic Description	Samples		Sample Type	Penet. Res.	Remarks TIP = Bkgnd/Reading (ppm)
					No.	Depth (ft)			
	1		ML-CC	CLAY, sm silt, to sand, brn v. moist no odor					
	5			SAA, brn/g rry, v. sl. odor incr. silt + sand, gravel			G		14:15 TUT 160
			ML-GC	SAA, GRAVEL, hard drilling					
	10		CC-SM	CLAY, SILT, SAND, wet, fuel odor gray - muddy cuttings			G		14:20
				SAA					
	15								
	20								
	25								
	30								

sl - slight	v - very	f - fine	<b>SAMPLE TYPE</b>	
tr - trace	lt - light	m - medium	D - DRIVE	C Core recovery
sm - some	dk - dark	c - coarse	C - CORE	
& - and	bf - buff	BH - Bore Hole	G - GRAB	Core lost
@ - at	brn - brown	SAA - Same As Above		
w - with	blk - black			

Water level drilled

# GEOLOGIC BORING LOG

BORING NO. VW5      CONTRACTOR: Rhodes      DATE SPUD: 10/18/93 1540  
 CLIENT: Grissom AFB      RIG TYPE: CME      DATE CMPL: 10/18/93  
 JOB NO.: DE 268.31.04      DRLG METHOD: HSA      ELEVATION: ~794  
 LOCATION: Bldg 735      BORING DIA.: 11"      TEMP.: \_\_\_\_\_  
 GEOLOGIST: JFH      DRLG FLUID: \_\_\_\_\_      WEATHER: \_\_\_\_\_  
 COMMENTS: \_\_\_\_\_

Elev. (ft.)	Depth (ft.)	Pro-file	US CS	Geologic Description	Samples		Sample Type	Penet. Res.	Remarks TIP = Bkgnd/Reading (ppm)
					No.	Depth (ft)			
	1			GRAVEL Fill w/clay					
			ML-CL	CLAY: SLT. to sm sand gray.					
				Swel odor wet strong					
	5			SAA strong odor			G		1545 TWH = >500
	10			SAA			G		1555 TWH = 960 TD = 13'
	15			slight - no odor					
	20								
	25								
	30								

sl - slight	v - very	f - fine	<b>SAMPLE TYPE</b>	
tr - trace	lt - light	m - medium	D - DRIVE	C - Core recovery
sm - some	dk - dark	c - coarse	C - CORE	
& - and	bf - buff	BH - Bore Hole	G - GRAB	Core lost
@ - at	brn - brown	SAA - Same As Above		
w - with	blk - black			

Water level drilled \_\_\_\_\_

# GEOLOGIC BORING LOG

BORING NO. <u>VW0</u>	CONTRACTOR: <u>Rhodes</u>	DATE SPUD: <u>10/18/93 16:50</u>
CLIENT: <u>Grissom AFB</u>	RIG TYPE: <u>CME</u>	DATE CMPL: <u>10/18/93</u>
JOB NO.: <u>DE268-31-04</u>	DRLG METHOD: <u>HSA</u>	ELEVATION: <u>~794</u>
LOCATION: <u>blg 735</u>	BORING DIA.: <u>11"</u>	TEMP.: <u>~45° F</u>
GEOLOGIST: <u>JFH</u>	DRLG FLUID: <u>—</u>	WEATHER: <u>p. cloudy wind</u>
COMMENTS:		

Elev. (ft.)	Depth (ft.)	Pro-file	US CS	Geologic Description	Samples		Sample Type	Penet. Res.	Remarks TIP = Bkgrnd/Reading (ppm)
					No.	Depth (ft)			
	1			GRAVEL & ASPHALT					
			ML-CC	CLAY + SILT tr. sand, gray v moist fuel odor					
	5		ML-CC	SAA, tr-sm gravel			D	8 20 1700	
			ML-CC	SAA - drier - moist, brn/gray fuel odor				13 18	TUH = 1800
				- drier w/ depth, fuel odor					
	10		ML-CC	incr. gravel w/ depth			G		TUH = 1000
				v hard drilling - breaker - 11'					
			ML-CC	v moist - wet below 11-12' no odor					
									TD = 14
	15								
	20								
	25								
	30								

sl - slight	v - very	f - fine	<b>SAMPLE TYPE</b>	
tr - trace	lt - light	m - medium	D - DRIVE	C - Core recovery
sm - some	dk - dark	c - coarse	C - CORE	
& - and	bf - buff	BH - Bore Hole	G - GRAB	Core lost
∅ - at	brn - brown	SAA - Same As Above		
- with	blk - black			

Water level drilled

# GEOLOGIC BORING LOG

BORING NO. UV7 9/11  
 CLIENT: Grisson AFB  
 JOB NO.: DE268-31-04  
 LOCATION: Bldg 735  
 GEOLOGIST: JFH  
 COMMENTS: A of UV1

CONTRACTOR: Rhodes  
 RIG TYPE: CME  
 DRLG METHOD: HSA  
 BORING DIA.: 11"  
 DRLG FLUID: ---

DATE SPUD: 10/14/93 1300  
 DATE CMPL: 10/19/93  
 ELEVATION: ---  
 TEMP.: 165°F  
 WEATHER: cloudy

Elev. (ft.)	Depth (ft.)	Pro-file	US CS	Geologic Description	Samples		Sample Type	Penet. Res.	Remarks TIP = Bkgnd/Reading (ppm)
					No.	Depth (ft)			
	1		ML-CL	CLAY & SILT, tr-sm sand & gravel, lt brn, v-wet no odor			G		
	5		GC	CLAY & SILT, sm sand, to gravel saturated no odor lt brn hard			D	>50	1315 TWH 75
	10		ML-SC	SILT, sm f. sand, tr-sm clay wet no odor lt brn					
	15		ML-GC	SILT, sm clay, tr-sm sand & gravel wet, soft gray no odor			D	125	1330 TD 15 - 86 ppmv
	20								
	25								
	30								

sl - slight      v - very      f - fine  
 tr - trace      lt - light      m - medium  
 sm - some      dk - dark      c - coarse  
 & - and      bf - buff      BH - Bore Hole  
 @ - at      brn - brown      SAA - Same As Above  
 w - with      blk - black

**SAMPLE TYPE**  
 D - DRIVE      C - Core recovery  
 C - CORE  
 G - GRAB      Core lost

Water level drilled

7.5' 12" screen  
 11.5 - 4.5'      11 sacks sand      backfilled to 11.5'  
 1/2 bkt pellets

## GEOLOGIC BORING LOG

BORING NO. <u>VW 8</u>	CONTRACTOR: <u>Alcocks</u>	DATE SPUD: <u>10/14/93 1530</u>
CLIENT: <u>Grissom AFB</u>	RIG TYPE: <u>CME</u>	DATE CMPL: <u>10/19/93</u>
JOB NO.: <u>DE 268.31.04</u>	DRLG METHOD: <u>HSA</u>	ELEVATION: <u>-794</u>
LOCATION: <u>Bldg 735</u>	BORING DIA.: <u>11"</u>	TEMP.: _____
GEOLOGIST: <u>JFH</u>	DRLG FLUID: _____	WEATHER: _____
COMMENTS: _____		

Elev. (ft.)	Depth (ft.)	Pro-file	US CS	Geologic Description	Samples		Sample Type	Penet. Res.	Remarks TIP = Bkgnd/Reading (ppm)
					No.	Depth (ft)			
	1		ML-SC	CLAY & SILT, tr sand, wd brn moist no odor SAA, lt brn v. moist @ 4'			G	15.40 TUH = 78	
	5		ML-SC	CLAY & SILT, sm sand, tr gravel gray w/ Fe stain? sl-moist-moist no odor w/ gravel @ 6.5' hard v. moist @ 9'			D	17.27 38 40	1550 TUH = 58
	10		ML-SC	SILT, sm clay & sand, wet soft no odor gray			G	2 2 4	TUH = 300? re-test 76 TUH = 30 TD = 15'
	15								
	20								
	25								
	30								

sl - slight	v - very	f - fine
tr - trace	lt - light	m - medium
sm - some	dk - dark	c - coarse
& - and	bf - buff	BH - Bore Hole
@ - at	brn - brown	SAA - Same As Above
w - with	blk - black	

**SAMPLE TYPE**  
 D - DRIVE    C - Core recovery  
 C - CORE  
 G - GRAB    Core lost

Water level drilled

7.5' screen  
11.5 - 4

8 Sand    1 1/2 screen  
2 pellets

# GEOLOGIC BORING LOG

BORING NO. <u>MPA</u>	CONTRACTOR: <u>Rherbs</u>	DATE SPUD: <u>10/13 16:20</u>
CLIENT: <u>Grassom AFB</u>	RIG TYPE: <u>CME</u>	DATE CML: <u>10/13 17:05</u>
JOB NO.: <u>DE268.31.04</u>	DRLG METHOD: <u>HSA</u>	ELEVATION: <u>~794</u>
LOCATION: <u>Blk 735</u>	BORING DIA.: <u>8"</u>	TEMP.: <u>~50°</u>
GEOLOGIST: <u>JFH</u>	DRLG FLUID: <u>—</u>	WEATHER: <u>p cloudy</u>

COMMENTS: \_\_\_\_\_

Elev. (ft.)	Depth (ft.)	Pro-file	US CS	Geologic Description	Samples		Sample Type	Penet. Res.	Remarks TIP = Bkgnd/Reading (ppm)
					No.	Depth (ft)			
	1		ML-CL	SILT & CLAY, dk brn, sl moist 18" auger hit rock?					
				SAA - gror, odor @ ~3' v. hard drilling		3-4	G		TUH 500
	5			SILT, sm clay & sand, md brn.		4-4.5	<del>X</del>	541	TUV 76
			ML-SC-GC	sl moist no odor no stain					
				SILT & SAND, tr-sm clay grey f					
			ML-SC	md brn (cuttings), tr-sm gravel					
	10			SILT, sm f. sand, tr clay md brn some grey stain sl. odor v moist water?		9-	D	50+	TUH 700
									TD=10'
	15								
	20								
	25								
	30								

sl - slight	v - very	f - fine
tr - trace	lt - light	m - medium
sm - some	dk - dark	c - coarse
& - and	bf - buff	BH - Bore Hole
@ - at	brn - brown	SAA - Same As Above
w - with	blk - black	

**SAMPLE TYPE**

D - DRIVE	C	Core recovery
C - CORE		
G - GRAB		Core lost

Water level drilled

# GEOLOGIC BORING LOG

BORING NO. <u>MPB</u>	CONTRACTOR: <u>Rhodes &amp; Assoc</u>	DATE SPUD: <u>10/14 0950</u>
CLIENT: <u>GRISSOM AFB</u>	RIG TYPE: <u>CME</u>	DATE CMPL: <u>10/14/43</u>
JOB NO.: <u>DE268-31.04</u>	DRLG METHOD: <u>ISA</u>	ELEVATION: <u>- 794</u>
LOCATION: <u>Bldg 735</u>	BORING DIA.: <u>8"</u>	TEMP.: <u>- 50°F</u>
GEOLOGIST: <u>JFH</u>	DRLG FLUID: <u>—</u>	WEATHER: <u>—</u>
COMMENTS: <u>—</u>		

Elev. (ft.)	Depth (ft.)	Pro-file	US CS	Geologic Description	Samples		Sample Type	Penet. Res.	Remarks TIP = Bkgnd/Reading (ppm)
					No.	Depth (ft)			
	1		CL- ML	CLAY, sm silt dk brn sl moist					
				CLAY & SILT md brn, sl moist no odor					
			cc- gc	0' Rocks					
			cc- sc	3-3.5 CLAY & SILT, brn & moist					10:10
	5			3.5 SILT, sm clay & sand gray	3-5		D	50 30 25 21	TUH=420
			ML- gc	v-moist + odor incr gravel below - 4.5'					
	10								
	15								
	20								
	25								
	30								

sl - slight	v - very	f - fine
tr - trace	lt - light	m - medium
sm - some	dk - dark	c - coarse
& - and	bf - buff	BH - Bore Hole
@ - at	brn - brown	SAA - Same As Above
w - with	blk - black	

**SAMPLE TYPE**  
 D - DRIVE    C - Core recovery  
 C - CORE  
 G - GRAB            Core lost

Water level drilled

# GEOLOGIC BORING LOG

BORING NO. <u>MDC</u>	CONTRACTOR: <u>RHOWE</u>	DATE SPUD: <u>10/14/93</u>	
CLIENT: <u>Grissom AFB</u>	RIG TYPE: <u>CME</u>	DATE CMPL: <u>10/14/93</u>	
JOB NO.: <u>DE 268.31.04</u>	DRLG METHOD: <u>HSA</u>	ELEVATION: <u>~ 784</u>	
LOCATION: <u>Bldg 735</u>	BORING DIA.: <u>8" OD</u>	TEMP.: <u>60</u>	
GEOLOGIST: <u>JFH</u>	DRLG FLUID: <u>None</u>	WEATHER: <u>p. sunny S. wind</u>	

COMMENTS: \_\_\_\_\_

Elev. (ft.)	Depth (ft.)	Pro-file	US CS	Geologic Description	Samples		Sample Type	Penet. Res.	Remarks TIP = Bkgrnd/Reading (ppm)
					No.	Depth (ft)			
	1		ML-CL	CLAY & SILT m & brn moist					
	5		ML-CL-GC	SAA, mottled w/ gray, Fe stain moist no odor, w/ sand & gravel @ ~ 4.5'			D	43 32 20	TUx 140 ppm TD = 5'
	10								
	15								
	20								
	25								
	30								

sl - slight	v - very	f - fine	<b>SAMPLE TYPE</b>	
tr - trace	lt - light	m - medium		
sm - some	dk - dark	c - coarse	C - CORE	
& - and	bf - buff	BH - Bore Hole	G - GRAB      Core lost	
@ - at	brn - brown	SAA - Same As Above		
w - with	blk - black		Water level drilled	

# GEOLOGIC BORING LOG

BORING NO. BL (MPE) CONTRACTOR: Rhodes & Assoc DATE SPUD: 10/15/93  
 CLIENT: Grissom RIG TYPE: CME DATE CMPL: 10/15/93  
 JOB NO.: DE268-31.04 DRLG METHOD: HSA ELEVATION: \_\_\_\_\_  
 LOCATION: Dump house 735 BORING DIA.: 8" TEMP.: ~55°F  
 GEOLOGIST: JFH DRLG FLUID: \_\_\_\_\_ WEATHER: overcast, W. breeze  
 COMMENTS: \_\_\_\_\_

Elev. (ft.)	Depth (ft.)	Pro-file	US CS	Geologic Description	Samples		Sample Type	Penet. Res.	Remarks TIP = Bkgmd/Reading (ppm)
					No.	Depth (ft)			
	1		ML- CL	CLAY & SILT md brn, v moist no o br					
			ML- CL- SC	CLAY & SILT, sm-tr sand, brn/gray laminated, moist no o br -			D	16 >50	0850
	5								TD=5'
	10								
	15								
	20								
	25								
	30								

sl - slight tr - trace sm - some & - and @ - at w - with	v - very lt - light dk - dark bf - buff brn - brown blk - black	f - fine m - medium c - coarse BH - Bore Hole SAA - Same As Above	<b>SAMPLE TYPE</b> D - DRIVE    C    Core recovery C - CORE G - GRAB        Core lost
---	--	---	--

Water level drilled

**APPENDIX B  
O&M CHECKLIST  
AND BLOWER SPECIFICATIONS**

## SYSTEM MAINTENANCE

This Appendix is a summary of the *Generic Bioventing Blower System Operations and Maintenance Manual for Extended Pilot Testing* (Engineering-Science, Inc., 1993) (O&M Manual). A copy of the O&M Manual has been supplied to Grissom AFB and should be referred to for additional details.

### B.1 BLOWER/MOTOR MAINTENANCE

The blowers and motors are relatively maintenance free. There is no lubrication required because the blowers and motors have sealed bearings. If a blower system is in need of repair, please contact John Hall at (303) 831-8100 or Bill Reid at (513) 881-2200.

### B.2 FILTER MAINTENANCE

To avoid damage caused by passing solids through the blowers, an air filter has been installed inline before each blower. The inline air filter will prevent solids from entering the blower, and is rated at 99 percent efficiency to 10 microns.

The filter element is a polyester cloth and can be cleaned and reused, or replaced. The filters should be checked weekly for the first 2 months of operation. The air filters should be cleaned or replaced when the pressure difference across the filter reaches 15 to 20 inches of water. It is the responsibility of Grissom AFB to determine the best schedule for filter cleaning and/or replacement, depending on the results of the initial observations.

The filters can be checked after turning off the blower system. To remove the filter, unscrew metal top off the air filter, and lift the air filter from the metal housing. When replacing the filter, be careful that the rubber seals remain in place. The filter is manufactured by Solberg Manufacturing, Inc. in Itasca, Illinois. Their phone number is (708) 773-1363. It is recommended that Grissom AFB keep a spare air filter at the site.

### B.3 BLOWER PERFORMANCE MONITORING

To monitor the blower performance, vacuum, pressure, and temperature will be measured. These data will be recorded on the data collection sheets provided. All measurements will be taken at the same time while the system is running.

### B.3.1 Pressure/Vacuum

Open the shed roof and record the pressure and vacuum readings directly from the gages in inches of water. Record the measurements on the data collection sheet provided.

### B.3.2 Temperature

Open the shed roof and record the temperature readings directly from the gages in degrees Fahrenheit. Record the measurements on the data collection sheet provided.

## B.4 MONITORING SCHEDULE

The following monitoring schedule is recommended for this system. During the initial months of operation, more frequent monitoring is recommended to ensure that any start up problems are quickly corrected. Data collection sheets have been provided to record the system data.

<u>Monitoring Item</u>	<u>Monitoring Frequency</u>
Blower vacuum and temperature	Weekly for the first 2 months of operation. Grissom AFB personnel then may optimize the schedule depending on the results of initial observations.