

LOAN DOCUMENT

PHOTOGRAPH THIS SHEET

DTIC ACCESSION NUMBER

LEVEL

INVENTORY

FINAL BIOVENTING PILOT TEST...

DOCUMENT IDENTIFICATION

JAN 95

DISTRIBUTION STATEMENT A
Approved for Public Release
Distribution Unlimited

DISTRIBUTION STATEMENT

ACCESSION FOR	
NTIS	GRAM <input checked="" type="checkbox"/>
DTIC	TRAC <input type="checkbox"/>
UNANNOUNCED	<input type="checkbox"/>
JUSTIFICATION	<input type="checkbox"/>
BY	
DISTRIBUTION/	
AVAILABILITY CODES	
DISTRIBUTION	AVAILABILITY AND/OR SPECIAL
<i>A-1</i>	

DISTRIBUTION STAMP

DATE ACCESSIONED

DATE RETURNED

DTIC QUALITY INSPECTED 4
20001226 013

DATE RECEIVED IN DTIC

REGISTERED OR CERTIFIED NUMBER

PHOTOGRAPH THIS SHEET AND RETURN TO DTIC-FDAC

H
A
N
D
L
E

W
I
T
H

C
A
R
E

**Final Bioventing Pilot Test Results Report for
Building 735 Pumphouse
Grissom AFB, Indiana**

Prepared For

**Air Force Center for Environmental Excellence
Brooks AFB, Texas**

and

**305 SPTG/DEV
Grissom AFB, Indiana**

January 1995

PARSONS ENGINEERING SCIENCE, INC.

1700 Broadway, Suite 900 • Denver, Colorado 80290

AGM01-03-0586

DEFENSE TECHNICAL INFORMATION CENTER
REQUEST FOR SCIENTIFIC AND TECHNICAL REPORTS

Title AFCEE Collection

1. Report Availability (Please check one box)

- This report is available. Complete sections 2a - 2f.
- This report is not available. Complete section 3.

2a. Number of
Copies Forwarded

1 each

2b. Forwarding Date

July 2000

2c. Distribution Statement (Please check ONE box)

DoD Directive 5230.24, "Distribution Statements on Technical Documents," 18 Mar 87, contains seven distribution statements, as described briefly below. Technical documents MUST be assigned a distribution statement.

- DISTRIBUTION STATEMENT A: Approved for public release. Distribution is unlimited.
- DISTRIBUTION STATEMENT B: Distribution authorized to U.S. Government Agencies only.
- DISTRIBUTION STATEMENT C: Distribution authorized to U.S. Government Agencies and their contractors.
- DISTRIBUTION STATEMENT D: Distribution authorized to U.S. Department of Defense (DoD) and U.S. DoD contractors only.
- DISTRIBUTION STATEMENT E: Distribution authorized to U.S. Department of Defense (DoD) employees only.
- DISTRIBUTION STATEMENT F: Further dissemination only as directed by the controlling DoD office included below or by higher authority.
- DISTRIBUTION STATEMENT X: Distribution authorized to U.S. Government agencies and private individuals or enterprises eligible to obtain export-controlled technical data in accordance with DoD Directive 5230.25, Withholding of Unclassified Technical Data from Public Disclosure, 6 Nov 84.

2d. Reason For the Above Distribution Statement (in accordance with DoD Directive 5230.24)

2e. Controlling Office

HQ AFCEE

2f. Date of Distribution Statement
Determination

15 Nov 2000

3. This report is NOT forwarded for the following reasons. (Please check appropriate box)

- It was previously forwarded to DTIC on _____ (date) and the AD number is _____
- It will be published at a later date. Enter approximate date if known. _____
- In accordance with the provisions of DoD Directive 5230.12, the requested document is not supplied because: _____

Print or Type Name

Laura Peña

Telephone

310-536 1151

Signature

[Signature]

AD No.

M01-03-0586

**FINAL BIOVENTING PILOT TEST RESULTS REPORT FOR
BUILDING 735 PUMPHOUSE
GRISSOM AFB, INDIANA**

Prepared for:

**AIR FORCE CENTER FOR ENVIRONMENTAL EXCELLENCE
BROOKS AFB, TEXAS**

AND

**305 SPTG/DEV
GRISSOM AFB, INDIANA**

January 1995

Prepared by:

**Parsons Engineering Science, Inc.
1700 Broadway, Suite 900
Denver, Colorado 80290**

TABLE OF CONTENTS

		Page
1.0	INTRODUCTION.....	1
2.0	PILOT TEST DESIGN AND CONSTRUCTION.....	1
2.1	System Design and Layout.....	1
2.2	System Operation.....	3
3.0	PILOT TEST RESULTS.....	7
3.1	Air Permeability.....	7
3.2	<i>In Situ</i> Respiration Rates.....	7
4.0	SOIL AND SOIL GAS SAMPLING RESULTS.....	8
4.1	Soil Analytical Results.....	9
4.2	Soil Gas VOC Results.....	10
5.0	SYSTEM MONITORING RESULTS.....	10
5.1	Groundwater Levels.....	10
5.2	Pressure Response.....	10
5.3	Soil Gas Oxygen Concentrations.....	14
5.4	Soil Gas VOCs.....	14
5.5	Dissolved Oxygen Concentrations.....	14
6.0	SYSTEM PERFORMANCE SUMMARY AND RECOMMENDATIONS.....	17
7.0	REFERENCES.....	18

LIST OF TABLES

<u>No.</u>	<u>Title</u>	<u>Page</u>
2.1	Well Construction Summary.....	5
3.1	Oxygen Utilization and Biodegradation Rates.....	8
4.1	Initial and 1-Year Soil Analytical Results.....	9
5.1	Groundwater Level Monitoring Results.....	11
5.2	Pressure Response Monitoring Results.....	13
5.3	Soil Gas Oxygen, Carbon Dioxide, and Volatile Organic Compound Monitoring Results.....	15
5.4	Groundwater Dissolved Oxygen Monitoring Results.....	16

LIST OF FIGURES

<u>No.</u>	<u>Title</u>	<u>Page</u>
2.1	As-Built Site Layout	2
2.2	Typical As-Built Injection/Vent Well Construction Detail	4
2.3	Typical As-Built Monitoring Point Construction Detail	6
5.1	Hydrogeologic Cross Section A-A'	12

SECTION 1

INTRODUCTION

The Air Force Center for Environmental Excellence (AFCEE) 1-year bioventing/air sparging pilot test at the Building 735 Pumphouse site at Grissom Air Force Base (AFB), Indiana has been completed. The purpose of this report is to describe the results of 1 year of continued system monitoring of the bioventing/air sparging system installed by Parsons Engineering Science, Inc. (Parsons ES), formerly Engineering-Science, Inc. (ES) at the Building 735 Pumphouse site. The system installation and pilot testing were conducted during the period from October 12 through 23, 1993. Parsons ES returned to the site to conduct additional testing and system monitoring on December 10, 1993, and March 11, June 7, and August, 18, 1994. Final monitoring, testing, and soil sampling were conducted during the period from October 17 through 20, 1994. Although initial respiration testing could not be completed due to high water table conditions in October 1993, the respiration tests conducted in June and October 1994, were successful, and microbial fuel degradation rates for the unsaturated soil zone were calculated from these data. Results from these tests are included in this report.

The results presented in this report support the initial and 6-month conclusions (ES, 1993b) that the system has been successfully introducing oxygen into the soil gas in the unsaturated zone, locally increasing dissolved oxygen concentrations in the contaminated groundwater, and locally depressing the groundwater level. Microbial fuel degradation should continue to be stimulated by the increased oxygen concentrations in the soil gas and groundwater. Groundwater depression has increased the efficiency of the system by exposing more of the contaminated soil profile to bioventing treatment. Descriptions of the history, geology, and contamination at Building 735, and the results of the initial testing are discussed in *Part I Bioventing Pilot Test Work Plan* (ES, 1993a) and *Part II Draft Interim Pilot Test Results Report for Building 735 Pumphouse Grissom AFB, Indiana* (ES, 1993b).

2.0 PILOT TEST DESIGN AND CONSTRUCTION

This section summarizes the design and construction of the modified bioventing system installed at Building 735. Detailed system descriptions are presented in the work plan (ES, 1993a) and draft interim test results report (ES, 1993b). The system installed at Building 735 was designed primarily to remediate the unsaturated soils utilizing the bioventing technology. However, because a large part of the contaminated soil volume is beneath the groundwater surface for much of the year (typically the winter and spring seasons), an air sparging system was incorporated into the bioventing design with the intention of remediating both saturated soils and groundwater during times of high groundwater levels.

2.1 System Design and Layout

The system installed at the Building 735 site is a combined bioventing and air sparging system. The layout of the system is shown in Figure 2.1. The system includes seven vent wells (VWs) connected to a 5.5-horsepower (hp) regenerative blower system via underground polyvinyl chloride (PVC) and galvanized iron pipes. Although eight VWs were installed, VW7 was not connected to the system because soil contamination was not detected at this location during drilling. VW7 was used for groundwater monitoring. Multiple-depth monitoring points (MPs) and existing groundwater monitoring wells (GMWs) and product recovery wells (PRWs) were used to monitor the effectiveness of the system in supplying oxygen to the soil gas and groundwater.

The blower was configured to inject air at a rate of approximately 50 standard cubic feet per minute (scfm) at a pressure of 83 inches of water. At 83 inches of water pressure, the system is capable of injecting air to a maximum depth of approximately 7.5 feet below the water surface. This injection pressure also depressed the groundwater surface in the vicinity of the VWs, exposing additional well screen and increasing the thickness of the unsaturated zone exposed to bioventing treatment.

The VWs were installed in contaminated soils with the screened intervals extending from approximately 4 feet below ground surface (bgs) to depths ranging from 8.7 to 11.5 feet bgs. The small stopcocks installed near the top of each VW well casing allow excess air from the blower to vent to the atmosphere when the entire screened interval is below the groundwater surface. Figure 2.2 shows typical construction details for the VWs, and Table 2.1 lists the well construction details.

The MP screens were installed at the various depths listed in Table 2.1. The five MPs (MPA, MPB, MPC, MPD, and MPE) at this site were constructed as shown in Figure 2.3. MPA, MPB, MPC, and MPD were designed to monitor soil gas vapor chemistry and pressure response in areas of soil and groundwater contamination. The background MP (MPE) was designed to evaluate subsurface conditions outside the area of soil contamination. However, subsequent monitoring results indicate low concentrations of fuel contamination at the location of MPE. Existing 2-inch-diameter GMWs and 8-inch-diameter PRWs were also utilized to monitor groundwater levels and dissolved oxygen (DO) concentrations.

2.2 System Operation

The system was designed to simultaneously deliver air to the unsaturated soils and to the groundwater via the VWs. Air is supplied to each VW through the 1-inch-diameter PVC air injection pipe (Figure 2.2). When the groundwater level in the VW is above the bottom of the air injection pipe, the air first bubbles through the water (increasing the dissolved oxygen concentration) then exits through the well screen into the unsaturated soils. When the water level in the VW is near or above the top of the screen, then the air is vented from the top of VW through a small-diameter stopcock. Venting allows air to continue bubbling through the water even though there is little or no flow through the well screen. The stopcock was sized to allow for sufficient air flow through the air injection pipe to saturate the groundwater in the VW with DO

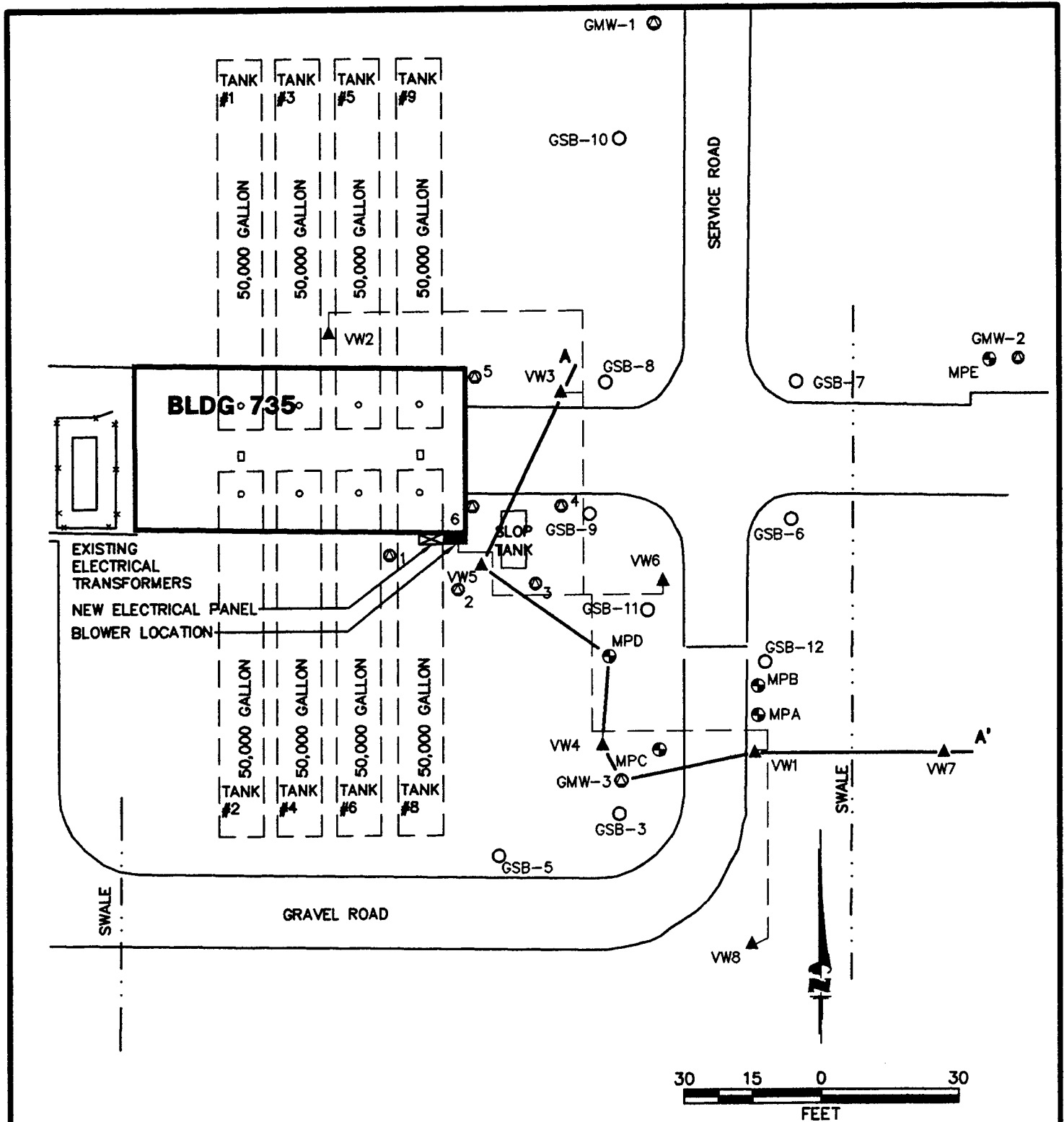

LEGEND

- ⊙ EXISTING MONITORING/PRODUCT RECOVERY WELL
- EXISTING SOIL BORING
- ▲ VENT/SPARGING WELL (AIR INJECTION)
- ⊕ VAPOR MONITORING POINT
- BURIED 2" PVC AIR LINE

FIGURE 2.1
AS-BUILT
SITE LAYOUT

Building 735
 Grissom Air Force Base
 Indiana

PARSONS
ENGINEERING SCIENCE, INC.
 Denver, Colorado

After TCT, 1992.

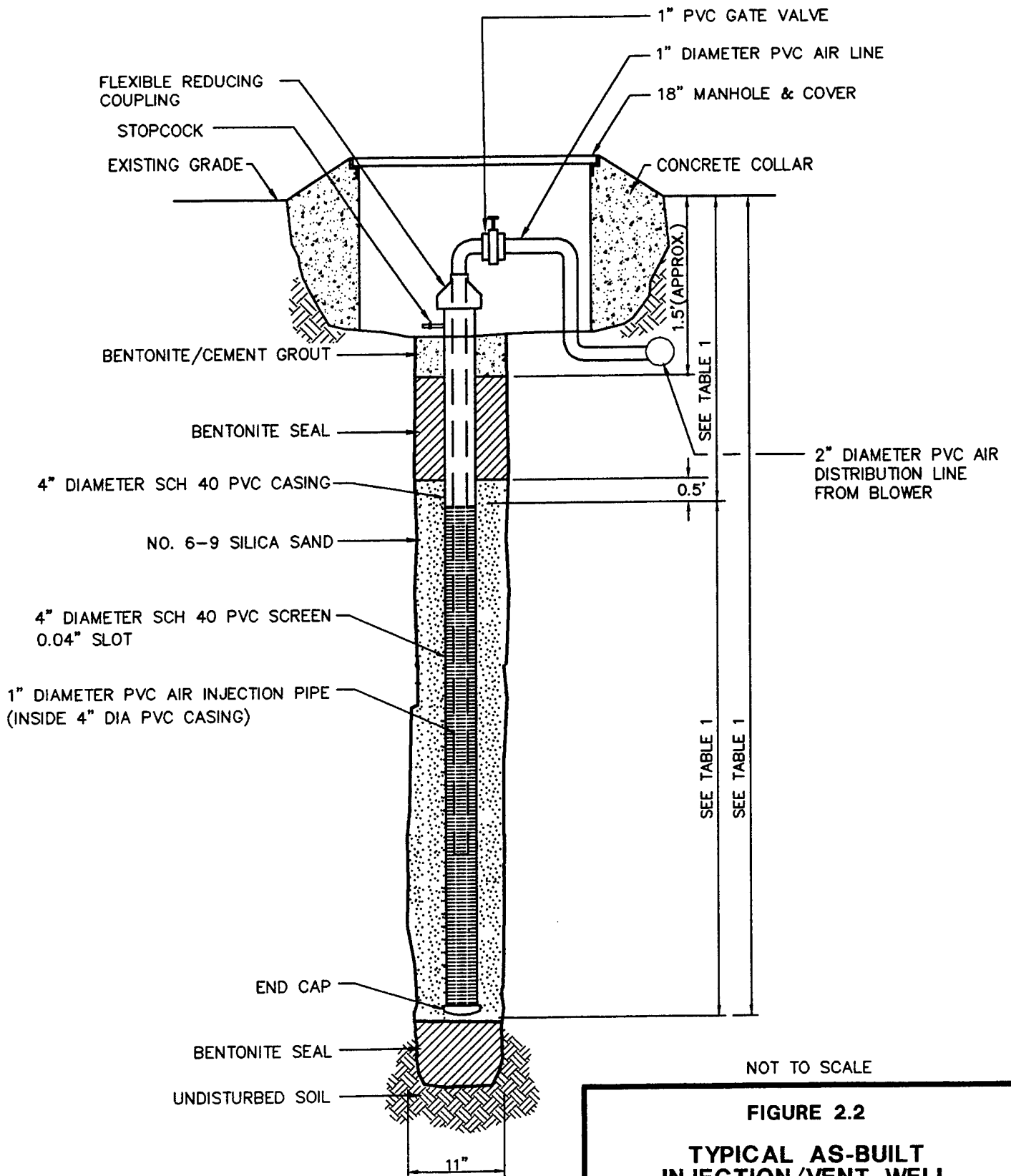

FIGURE 2.2
TYPICAL AS-BUILT
INJECTION/VENT WELL
CONSTRUCTION DETAIL

Building 735
 Grissom Air Force Base
 Indiana

PARSONS
ENGINEERING SCIENCE, INC.

Denver, Colorado

TABLE 2.1
WELL CONSTRUCTION SUMMARY
BUILDING 735
GRISSOM AFB, INDIANA

Well ID a/	Date Completed	Total Borehole Depth (feet bgs) b/	Screened Interval (feet bgs)
VW1	10/13/93	9	3.7-8.7
VW2	10/18/93	14	4-12
VW3	10/18/93	12	4-11.5
VW4	10/18/93	14	4-11.5
VW5	10/18/93	13	4.5-11.5
VW6	10/18/93	14	4-11.5
VW7	10/19/93	15	4.5-11.5
VW8	10/19/93	15	4.5-11.5
MPA	10/14/93	10	3, 9
MPB	10/14/93	7	3, 6
MPC	10/14/93	5	3.5
MPD	10/20/93	10	4, 8
MPE	10/15/93	5	3

a/ ID = identification.

b/ bgs = below ground surface.

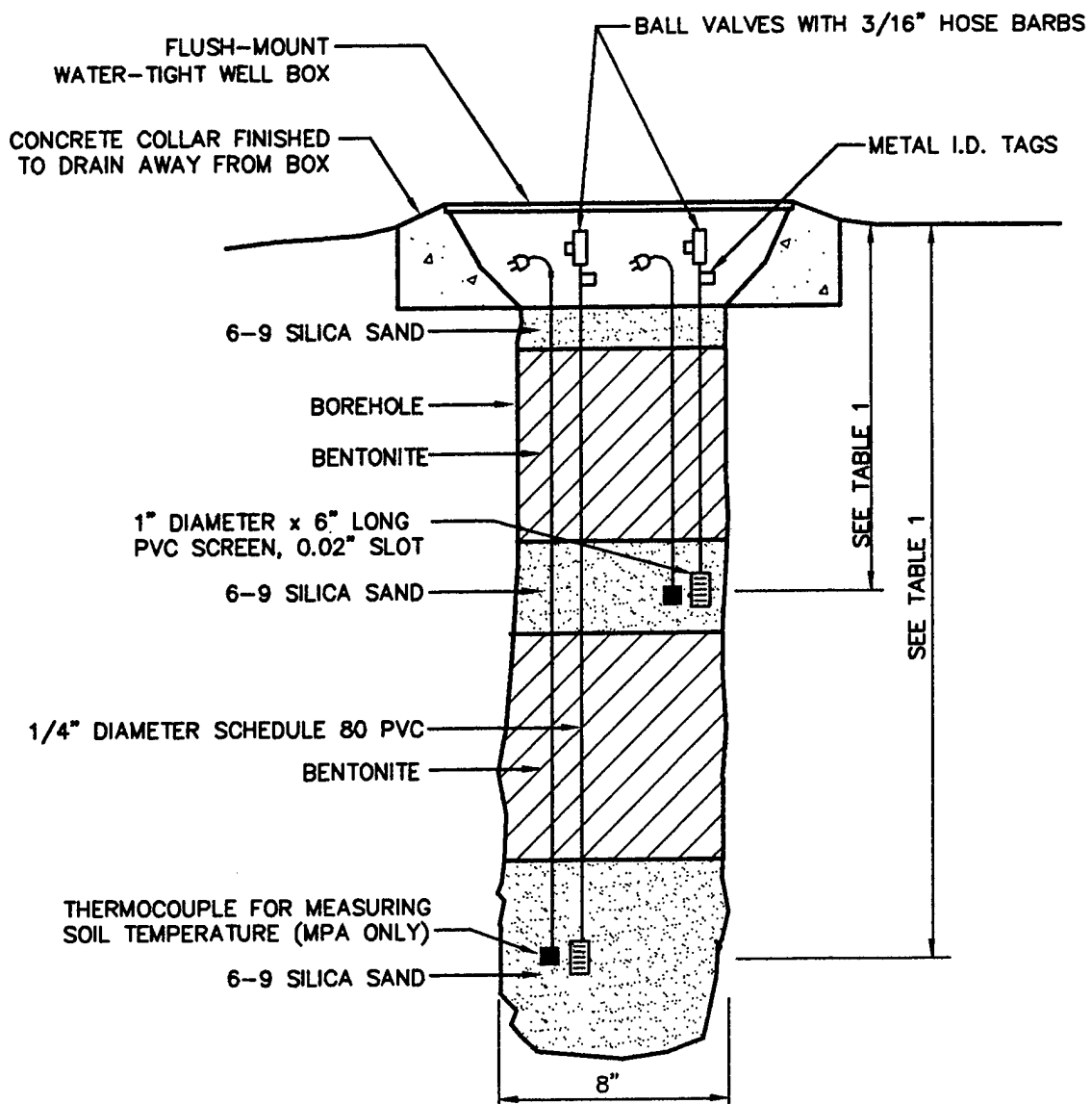

NOT TO SCALE

FIGURE 2.3
TYPICAL AS-BUILT
MONITORING POINT
CONSTRUCTION DETAIL

Building 735
 Grissom Air Force Base
 Indiana

PARSONS
ENGINEERING SCIENCE, INC.

Denver, Colorado

while partially restricting the flow to maintain an air pressure of approximately 70 inches of water within the VW casing.

Maintaining pressure within the VW serves two purposes; it locally depresses the groundwater surface and provides a pressure gradient to force air into the unsaturated soil. Depressing the groundwater surface exposes a thicker zone of unsaturated soils that can be exposed to air (oxygen) flow and remediated with bioventing.

The air pressure in the VWs forces air into the surrounding unsaturated soils whenever the top of the groundwater surface falls below the top of the VW screen, as the result of pressure-induced groundwater level depression or seasonal variations. As the length of screen above the water level increases, air flow to the VW and into the soil increases proportionately.

The blower system is designed with sufficient reserve air flow capacity to automatically increase the flow rate to the wells as more VW screen is exposed due to falling groundwater levels. A manual bleed valve and an automatic pressure relief valve (PRV) adjust the air flow to the VWs while maintaining a constant injection pressure of approximately 83 inches of water. The blower system is designed to automatically increase air flow to the VWs, as more VW screen is exposed, by reducing the flow through the PRV.

3.0 PILOT TEST RESULTS

3.1 Air Permeability

An air permeability test was conducted on June 9, 1994, according to bioventing protocol procedures (Hinchee *et al.*, 1992). Air was injected into VW1 for 40 minutes at a rate of approximately 3 scfm and an average pressure of 85 inches of water. Air flow to the remaining VWs was turned off for the duration of the permeability test. Significant pressure response was measured in only MPA and MPB. Maximum pressures of 0.90 and 0.26 inches of water were measured at the 3-foot depth at MPA and MPB, respectively. The pressure measured at the MPs increased rapidly during the first 5 to 10 minutes of the test, then at a much slower rate for the remainder of the test. Due to the rapid pressure response, the steady-state method of determining air permeability was selected. A soil gas permeability value of 0.15 darcys, typical for silty, clayey sand, was calculated for this site.

A radius of pressure influence of between 16.5 and 20 feet was observed while injecting at only VW1. However, when the system is injecting air at all VWs, a maximum pressure response of 10.0 inches of water has been measured at MPD-4, located a distance of 20 feet from the nearest VW, indicating that the radius of pressure influence exceeds 20 feet when injecting at all VWs. This conclusion is supported by the fact that high soil gas oxygen concentrations were measured at the MPs during the 1-year period of air injection at all VWs, as discussed in Section 5.2.

3.2 *IN SITU* RESPIRATION RATES

Two *in situ* respiration tests were performed at Building 735 by turning off the blower then measuring changes in the soil gas composition over time. Oxygen loss and

other changes in soil gas composition were measured at the MP intervals which had elevated oxygen levels resulting from air injection at the VWs. Oxygen, total volatile hydrocarbons (TVH), and carbon dioxide were measured for a period of approximately 2 days following air injection. The measured oxygen losses were then used to calculate biological oxygen utilization rates. Respiration test results are summarized in Table 3.1. The calculated biodegradation rates have varied slightly during the 1-year pilot test. These changes are best explained by soil temperature and moisture variations.

TABLE 3.1
OXYGEN UTILIZATION AND RESPIRATION BIODEGRADATION RATES
BUILDING 735 PUMPHOUSE
GRISSOM AFB, INDIANA

Location- Depth	6-Month (06/07/94)			1-Year (10/18/94)		
	Ko (% O2/min)	Degradation Rate (mg/kg/year)	Soil Temperature (°C)	Ko (% O2/min)	Degradation Rate (mg/kg/year)	Soil Temperature (°C)
MPA-3	0.0077	78	16.5	0.0026	225	15.3
MPA-9	----	----	10.1	----	----	15.2
MPB-3	0.0060	519	----	0.0038	291	----
MPC-3.5	----	----	----	0.0014	107	----
MPD-4	0.0004	19	----	0.0015	115	----

Results from these tests indicate that biologically active, contaminated soil exists at depths of 3 to 4 feet bgs in MPA, MPB, MPC, and MPD. Soil samples collected from MPA at a depth of 4 feet and from MPB at a depth of 3 feet had total recoverable petroleum hydrocarbon (TRPH) concentrations of 190 and 340 mg/kg, respectively. Decreasing oxygen concentrations measured in the soil gas collected from the MPs during the respiration tests indicate moderate biological activity associated with the contamination. Soils at MPC appear to be less contaminated, as indicated by lower soil gas TVH and slower respiration rates.

Oxygen loss measured at MPA, MPB, MPC, and MPD occurred at moderate rates, ranging from 0.0077 percent per minute at MPA-3 to 0.0004 percent per minute at MPD-4. At MPA-6, the oxygen dropped from 18.9 percent to 8.5 percent in 1,410 minutes.

Based on these oxygen utilization rates, an estimated 519 to 19 milligrams (mg) of fuel per kilogram (kg) of soil (at MPB-3 and MPD-4, respectively) can be degraded each year at this site. This range is conservatively estimated based on air-filled porosity of between approximately 0.043 and 0.024 liter of air per kg of soil, and a ratio of 3.5 mg of oxygen consumed for every 1 mg of fuel biodegraded. Actual degradation rates may exceed these estimates.

4.0 SOIL AND SOIL GAS SAMPLING RESULTS

The 1-year sampling effort was not intended to collect the large number of samples required for a statistical analysis of contaminant removal. It was conducted to give a qualitative indication of changes in contaminant mass at selected locations. Soil gas samples are somewhat similar to composite soil samples in that they represent an average soil gas concentration in several cubic feet of soil. Thus, they provide a good indication of changes in volatile contaminant mass (See Addendum One to Test Plan and Technical Protocol for a Field Treatability Test for Bioventing, 1994) (Downey and Hall, 1994). Soil samples, on the other hand, are discrete point samples subject to large variabilities over small distances and changes in soil type. This variability, coupled with known sampling and analytical variabilities, would require the collection of a large number of samples to conclusively determine statistically verifiable changes in soil contamination. Due to the limited number of final samples collected under this effort, these results should be viewed only as qualitative indicators of bioventing progress. *In situ* respiration tests are considered to be better indicators of ongoing hydrocarbon remediation than limited soil sampling .

4.1 Soil Analytical Results

Initial and 1-year soil sampling results indicate that reductions both in benzene, toluene, ethylbenzene, and xylenes (BTEX) and in TRPH compounds have taken place in the unsaturated soils within the effective treatment area. Table 4.1 provides a summary of initial and final soil sampling results for TRPH and BTEX. As discussed above, these reductions probably represent a combination of actual fuel degradation combined with sampling and analytical variations.

TABLE 4.1
INITIAL AND 1-YEAR SOIL ANALYTICAL RESULTS
BUILDING 735 PUMPHOUSE
GRISSOM AFB, INDIANA

Soil Results	Sample Location-Depth (feet below ground surface)							
	MPA-4		MPB-4		VW3-6		VW6-6	
	Initial	1-Year	Initial	1-Year	Initial	1-Year	Initial	1-year
TPH: Mod. 8015 mg/kg) a/	NS ^{b/}	14	NS	16.0	NS	170	NS	ND ^{c/}
TRPH: 418.1 (mg/kg)	190	432	34	ND	4330	274	660	39
Benzene (µg/kg) d/	ND	ND	44	ND	28000	170	5200	ND
Toluene (µg/kg)	830	ND	12	510.	74000	240	6800	ND
Ethylbenzene (µg/kg)	1800	62	22	68.0	47000	130	18000	ND
Xylenes (µg/kg)	5000	570	64	720.	200000	220	68000	ND
Moisture (percent)	14	10	10	10.5	11	6	11	7

a/ mg/kg = milligram per kilogram

b/ NS = not sampled.

c/ ND = not detected.

d/ µg/kg = microgram per kilogram.

e/ TPH analysis = M8015 & TRPH analysis = 418.1.

4.2 Soil Gas VOC Results

Only total volatile organic compound (VOC) concentrations were measured at this site. Baseline concentrations of BTEX compounds could not be established because of sampling difficulties. Representative initial soil gas samples for laboratory BTEX analyses could not be collected because of the very shallow groundwater level and the subsequent saturated or near-saturated condition of the soils. However, total VOC concentrations were monitored in soil gas samples collected beginning in March 1994. VOC monitoring results are presented in Section 5.4.

5.0 SYSTEM MONITORING RESULTS

The bioventing system installed at Building 735 has been periodically monitored by Parsons ES to evaluate system performance. The parameters monitored include pressure response; groundwater level; groundwater DO concentration; soil gas oxygen, carbon dioxide, and TVH concentrations; and blower system pressure and air flow rate. In addition to the initial measurements taken in October 1993, system monitoring was conducted on December 10, 1993, and March 3, June 7, August 18, and October 17, 1994 by Parsons ES field engineers. The following sections present the system monitoring results.

5.1 Groundwater Levels

Groundwater levels have changed (generally decreasing) relative to the initial levels at all measurement locations, as shown on Table 5.1. Figure 5.1 is a hydrogeologic cross section of the site showing the groundwater levels measured on October 22, 1993 (before air injection), and on March 11 and October 18, 1994 (during air injection). Figure 2.1 shows the location of the cross section. In March 1994, at monitoring locations outside the area of pressure influence (VW7, GMW2, and some of the PRWs), the groundwater levels had generally risen, which is consistent with the seasonal pattern of higher levels from late fall to early spring. However, during this same period, as the result of air injection at the VWs, groundwater levels had fallen as much as 5 feet within the area of pressure influence of the VWs. The decrease in groundwater levels is roughly proportional to the induced soil gas pressure. Pressure-induced groundwater depression decreases with increasing distance from the VWs. Since March 1993, the groundwater elevations have remained lower within the area of pressure influence, and have generally decreased with time. Some, if not most of the additional decrease in groundwater levels measured after March 1993, appears to be the result of generally drier weather conditions, as indicated by a decrease in water levels outside the area of pressure influence. The lowest groundwater levels encountered during the 1-year pilot test were measured in October 1994.

5.2 Pressure Response

Pressure response at the MPs, resulting from air injection at the VWs, was measured throughout the 1-year period of air injection. Pressure response monitoring results are presented in Table 5.2. During the initial pilot testing conducted in October 1993, significant pressure response resulting from air injection at the VWs was measured at only the 3- and 4-foot depths at MPA and MPD, respectively. The remainder of the vapor probes at MPA through MPD had no measurable pressure response, presumably

TABLE 5.1

GROUNDWATER LEVEL MONITORING RESULTS ^{a/}
 BUILDING 735 PUMPHOUSE
 GRISSOM AFB, INDIANA

Date ----->	1993			1994							
	10/22	12/10	03/11	06/07	06/08	06/09	08/18	10/17	10/18	10/19	10/20
Comments ---->					blower off				blower off	rain	
Location											
PRW-1	--- b/	0.28	0.70	3.46	---	3.52	2.32	---	3.91	3.91	3.94
PRW-2	---	0.45	0.83	2.09	---	2.22	1.73	---	2.84	2.83	2.84
PRW-3	---	0.53	0.82	1.67	---	1.41	1.08	---	1.52	0.44	0.61
PRW-5	---	0.33	0.58	1.42	---	0.55	0.82	---	1.30	0.30	0.45
PRW-6	---	----	0.32	1.17	---	0.31	0.57	---	1.12	0.04	0.21
GMW-2	----	0.83	1.77	3.94	4.23	4.19	2.62	---	---	---	---
GMW-3	4.83	2.36	3.26	7.86	6.23	5.85	3.89	---	---	---	---
VW-1	2.92	---	---	8.45	8.03	7.31	5.61	---	> 8.83	8.24	7.95
VW-2	2.69	---	---	6.92	5.02	4.13	5.38	---	> 7.77	5.97	5.74
VW-3	2.09	---	6.61	7.77	4.10	4.07	6.58	---	7.77	5.25	5.25
VW-4	3.58	---	8.62	10.45	6.39	5.88	8.65	---	9.37	6.78	6.52
VW-5	3.70	---	7.42	9.86	5.76	4.08	5.63	---	10.16	---	---
VW-6	2.38	---	4.97	9.20	8.06	5.72	6.48	---	8.44	7.50	6.53
VW-7	1.50	---	0.70	3.80	4.22	4.08	2.46	---	4.81	4.88	4.85
VW-8	4.13	---	---	11.00	6.52	6.38	9.69	---	9.70	7.14	7.13
MPA-9	---	---	---	4.33	4.58	5.25	3.20	3.86	4.98	5.90	5.83
MPB-6	---	---	---	4.17	5.33	5.17	2.21	3.04	4.19	6.06	5.83
MPD-8	---	---	---	4.33	5.33	5.50	6.42	5.83	5.04	6.48	6.46

a/ Groundwater levels reported as depth below ground surface (feet).

b/ --- = not measured.

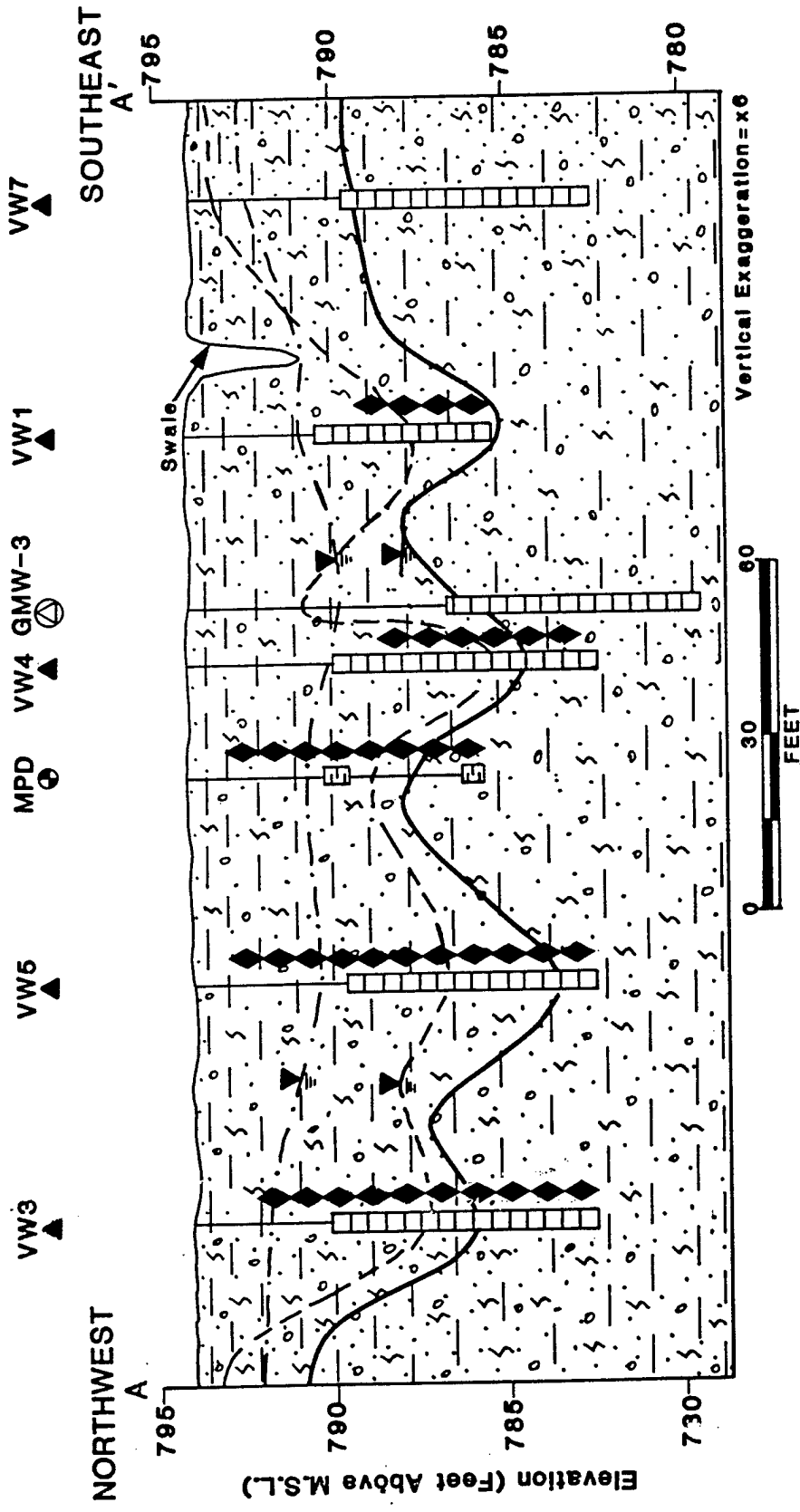

FIGURE 5.1

**HYDROGEOLOGIC
CROSS SECTION A-A'
BUILDING 735**

GRISSON AFB, INDIANA



LITHOLOGIC DESCRIPTION

□ SILT, CLAY, SAND, AND GRAVEL

LEGEND

- MPD ● MONITORING POINT
- VW-3 ▲ VENT WELL
- GROUNDWATER MONITORING WELL
- ◆ FUEL ODOR DETECTED DURING DRILLING
- GROUNDWATER ELEVATION 10/23/93
- GROUNDWATER ELEVATION 3/11/94
- GROUNDWATER ELEVATION 10/18/94
- SCREENED INTERVAL
- M.S.L. MEAN SEA LEVEL

TABLE 5.2

PRESSURE RESPONSE MONITORING RESULTS^{a/}
 BUILDING 735 PUMPHOUSE
 GRISSOM AFB, INDIANA

Location	10/22/93	12/10/93	3/11/94	06/07/94	08/18/94	10/17/94
Blower outlet	83	83	83	83	77	72
MPA-3	<0.05	20.0	8.6	< 0.05	< 0.05	1.10
MPA-9	<0.05	<0.05	<0.05	< 0.05	< 0.05	< 0.05
MPB-3	<0.05	4.2	4.0	16.0	< 0.05	9.20
MPB-6	<0.05	1.4	<0.05	< 0.05	0.14	< 0.05
MPC-3.5	<0.05	26.0	2.2	0.06	< 0.05	< 0.05
MPD-4	0.8 <0.05	10.0 <0.05	10.0 <0.05	1.80 < 0.05	1.00 0.88	1.80 < 0.05
MPD-8						
MPE-3	---- ^{b/}	4.6	10.0	- 1.00	7.4	< 0.05

^{a/} Pressure reported in inches of water.

^{b/} ---- = Not measured.

as the result of being located in saturated soil near or below the groundwater surface. During subsequent monitoring events, pressure was measured at all the vapor probes installed less than 6 feet bgs. Significant pressure response (greater than 1 inch of water) was measured at the shallow depths at MPs A, B, C, and D on December 10, 1993, following approximately 7 weeks of system operation. Pressure responses measured at the MPs between March and October 1994 have fluctuated, presumably due to changes in soil moisture. The pressure response measured at the MPs confirm that the well spacing and air injection rates are sufficient to influence the entire area of soils with TPH contamination exceeding the Indiana Department of Environmental Management regulatory action level of 100 mg/kg.

5.3 Soil Gas Oxygen

Increasing the soil gas oxygen concentrations to enhance microbial fuel degradation is the primary goal of a bioventing system. Table 5.3 includes the soil gas oxygen concentration measurements collected during 1 year of system operation. These measurements show that the system installed at Building 735 has been successful maintaining soil gas oxygen concentrations between 13.0 and 20.7 percent throughout the unsaturated soil interval.

Soil gas oxygen concentrations were measured at all the MP intervals screened above the groundwater surface. Because of the very low permeability of the soils to air flow (the result of fine soil grain size and high moisture content), and because many of the MP screened intervals were below the groundwater surface, it was not possible to collect representative initial soil gas samples for oxygen concentration measurements.

After approximately 4 months of air injection at the VWs, soil gas samples were successfully collected from all MP screened intervals installed at or above 4 feet bgs, and all samples had oxygen concentrations near atmospheric levels (20.7 percent), ranging from 18.0 to 20.5 percent. Subsequent soil gas oxygen measurements have remained above 13 percent at all MPs within the treatment area. The screened intervals at the 8- and 9-foot depths have remained below the groundwater surface, preventing collection of soil gas samples.

5.4 Soil Gas VOCs

Although initial soil gas samples could not be collected due to high groundwater levels and high soil moisture, by March 1994, continued air injection had depressed the groundwater levels and dried the soils sufficiently to allow collection of soil gas samples for field VOC analysis with a total volatile hydrocarbon analyzer. As shown on Table 5.3, changes in soil gas VOC concentrations were sporadic, possibly the result of changing groundwater levels exposing soils with varying levels of fuel contamination.

5.5 Dissolved Oxygen

Baseline groundwater DO concentrations were measured in existing wells GMW-2 and GMW-3; PRWs -1, -2, -3, and -4; and all VWs on October 22, 1993. DO concentrations were measured again in December 1993, and March, June, August, and

TABLE 5.3

**SOIL GAS OXYGEN, CARBON DIOXIDE, AND VOLATILE ORGANIC COMPOUND
MONITORING RESULTS
BUILDING 735, GRISSOM AFB, INDIANA**

Location- depth	10/22/93	12/10/93	03/11/94	06/07/94	06/09/94	08/18/94	10/17/94	10/20/94
<u>OXYGEN a/</u>								
MPA-3	--- b/	---	20.0	18.9	6.0	11.0	16.3	11.2
MPB-3	---	---	19.5	18.8	5.0	14.8	20.7	9.3
MPC-3.5	---	---	20.5	---	---	13.0	18.0	14.5
MPD-4	---	---	21.0	16.8	---	15.5	19.0	14.8
BG-3	---	---	15.0	13.0	---	16.2	3.0	3.8
<u>CARBON DIOXIDE c/</u>								
MPA-3	---	---	0.9	2.3	3.3	4.9	3.0	4.5
MPB-3	---	---	1.0	3.2	3.2	2.8	0.5	3.3
MPC-3.5	---	---	0.8	---	---	4.7	1.8	9.5
MPD-4	---	---	0.7	4.1	---	3.9	1.0	5.7
BG-3	---	---	2.2	---	---	2.1	4.3	4.8
<u>VOLATILE ORGANIC COMPOUNDS d/</u>								
MPA-3	---	---	1002	4600	5000	529	1138	438
MPB-3	---	---	2256	2000	5200	144	206	350
MPC-3.5	---	---	61	---	---	627	168	26
MPD-4	---	---	1091	>10,000	---	1041	1135	625
BG-3	---	---	120	---	---	26	24	144

a/ Oxygen concentrations reported in percent.

b/ --- = not measured.

c/ Carbon dioxide concentrations reported in percent.

d/ Volatile organic compounds reported in parts per million, volume per volume (ppmv).

October 1994, during the approximately 1-year period of continuous air injection at the VWs. DO measurements are summarized in Table 5.4.

Outside the areas of soil and groundwater contamination, initial groundwater DO concentrations were greater than 7 milligrams per liter (mg/L), which is typical for shallow groundwater. In contrast, DO was depleted (less than 1 mg/L) in the groundwater at most locations within the area of soil contamination. Groundwater is also contaminated within the area having depleted DO concentrations. Laboratory analyses detected total petroleum hydrocarbons (TPH) at a concentration of 0.412 mg/L, and benzene, ethylbenzene, and m-xylene at concentrations of 240 micrograms per liter ($\mu\text{g/L}$), 6.68 $\mu\text{g/L}$, and 3.2 $\mu\text{g/L}$, respectively, in a groundwater sample from GMW-3 (TCT-St. Louis, 1992). Depleted DO indicates that microbial fuel biodegradation is occurring in areas with soil and groundwater contamination, and that the addition of oxygen will increase fuel biodegradation activity.

DO concentrations were measured periodically during the 1-year period of system operation to evaluate the effect of system operation on the groundwater DO concentrations. As shown in Table 5.4, DO concentrations generally increased in the VWs and PRWs. Some increases (especially in the VWs) can be attributed to air injection at the VWs; however, increased DO concentrations measured at the PRWs may also be attributed to other factors such as varying water levels.

The DO concentrations measured in the VWs increased significantly during the first few months of air injection, when the water levels were above the bottom of the air injection pipes and the air bubbled through the water. As the water levels continued to drop to levels below the bottom of the air injection pipes, however, air no longer bubbled through the water. As a result, the DO concentrations fell to near the initial concentrations.

Interpreting the DO results from the PRWs is complicated by the fact that most of these wells are shallow, and at times had only a few inches of water in the casings. When the water levels were high, the DO was measured a few feet below the water surface, but when the water levels dropped, measurements were necessarily taken near the water surface (because of the very shallow water), and measured increases in DO were likely the result of oxygen diffusion from the water surface. The increase in DO at PRW-6 can be attributed to air sparging. The initial DO concentration, less than 0.2 mg/L, measured at PRW-5 increased to 9.8 mg/L after approximately 6 weeks of air injection at the VWs, and has remained above 6.6 mg/L throughout the 1-year pilot test period. The water level in PRW-6 has remained near the ground surface, providing a relatively thick water column in the well casing in which to measure the DO, so that the measured increase in DO is most likely the result of air sparging at VW5.

These results indicate that the bioventing system installed at Building 735 has been introducing oxygen into the groundwater. However, because of the DO monitoring limitations discussed above (shallow water column in the PRWs), the uniformity and volume of groundwater affected by increased DO has not been established.

TABLE 5.4

GROUNDWATER DISSOLVED OXYGEN MONITORING RESULTS^{a/}
 BUILDING 735 PUMPHOUSE
 GRISSOM AFB, INDIANA

Location	10/22/93	12/10/93	3/11/94	10/18/94
PRW-1	7.20	9.12	7.19	----
PRW-2	0.10	0.67	1.86	4.61
PRW-3	0.05	0.91	2.53	2.75
PRW-5	---- ^{b/}	0.43	2.12	3.07
PRW-6	0.00	9.80	8.10	----
GMW-2	0.00	0.32	0.97	----
GMW-3	0.09	0.36	7.05	----
VW-1	0.06	----	----	dry
VW-2	0.00	----	----	dry
VW-3	3.07	----	----	2.65
VW-4	0.90	----	6.10	3.00
VW-5	----	----	12.08	3.08
VW-6	0.00	----	14.67	3.40
VW-7	6.82	----	----	3.62
VW-8	7.57	----	----	3.42

^{a/} Dissolved oxygen concentrations reported in milligrams per liter (mg/L).

^{b/} ---- = not measured.

6.0 SYSTEM PERFORMANCE SUMMARY AND RECOMMENDATIONS

Overall, the bioventing system installed at Building 735 is performing as designed. Groundwater levels throughout most of the treatment area have decreased significantly. Soil gas oxygen concentrations have remained between 13 and 21 percent, which should stimulate fuel biodegradation in the unsaturated soil zone. Respiration rates, ranging from approximately 19 to 519 mg/kg/year, indicate significant fuel biodegradation is occurring at this site. The DO concentration in the groundwater near the VWs has also increased which should increase the rate of biodegradation in the groundwater and saturated soil zone. However, groundwater monitoring limitations prevented determining the full extent of increased DO within the treatment area.

The expanded bioventing pilot system is currently remediating contaminated soils from ground surface to an average depth of 4 feet bgs. During dry periods of the year, the depth of bioventing treatment will extend deeper into the soil column. During high water table conditions, this unique air injection design is providing additional DO to fuel-contaminated groundwater and saturated soils, and is enhancing the natural biodegradation of fuel residuals. Parsons ES recommends that the existing system be maintained and continue to operate on the site to enhance petroleum hydrocarbon source removal. Based on the limited permeability of site soils, the existing groundwater contamination will likely have little opportunity for migration, and any BTEX compounds in groundwater outside of the area of air sparging influence should be naturally attenuated over time. Further groundwater sampling to document natural attenuation processes is also recommended.

7.0 REFERENCES

- Downey, D.C., and J. Hall. 1994. *Addendum One to Test Plan and Technical Protocol for a Field Treatability Test for Bioventing, 1994*. Prepared for USAF Center for Environmental Excellence. February.
- Hinchee, R.E., S.K. Ong., R.N. Miller, D.C. Downey, and R. Frandt. 1992. *Test Plan and Technical Protocol for a Field Treatability Test for Bioventing*. Prepared for USAF Center for Environmental Excellence. May.
- Engineering-Science, Inc. 1993a. Bioventing Pilot Test Work Plan for Building 735 Pumphouse, Grissom AFB, Indiana. Denver, Colorado.
- Engineering-Science, Inc. 1993b. Draft Interim Pilot Test Results Report for Building 735 Pumphouse, Grissom AFB, Indiana. Denver, Colorado.
- TCT - St. Louis. 1992. *Remedial Action Investigation Leaking Underground Storage Tanks* Grissom Air Force Base, Indiana. St. Louis, Missouri.