

LOAN DOCUMENT

PHOTOGRAPH THIS SHEET

DTIC ACCESSION NUMBER



LEVEL

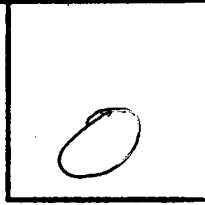

INVENTORY

BIOVENTING BLOWER SYSTEM ...

DOCUMENT IDENTIFICATION

MAY 96

DISTRIBUTION STATEMENT A
Approved for Public Release
Distribution Unlimited

DISTRIBUTION STATEMENT

ACCESSION FOR	
NTIS	GRAM <input checked="" type="checkbox"/>
DTIC	TRAC <input type="checkbox"/>
UNANNOUNCED	<input type="checkbox"/>
JUSTIFICATION	<input type="checkbox"/>
BY	
DISTRIBUTION/	
AVAILABILITY CODES	
DISTRIBUTION	AVAILABILITY AND/OR SPECIAL
<i>A-1</i>	

DISTRIBUTION STAMP

DATE ACCESSIONED

DATE RETURNED

DTIC QUALITY INSPECTED 4

20001226 019

DATE RECEIVED IN DTIC

REGISTERED OR CERTIFIED NUMBER

PHOTOGRAPH THIS SHEET AND RETURN TO DTIC-FDAC

H
A
N
D
L
E

W
I
T
H

C
A
R
E

**Bioventing Blower System
Operations and Maintenance Manual
LPST No. 98508, Building 675
Fort Bliss, Texas**

Prepared For



**The US Army Environmental Center
Aberdeen Proving Ground, Maryland**

**Fort Bliss
El Paso, Texas**

and



**Air Force Center for Environmental Excellence
Brooks Air Force Base
San Antonio, Texas**

May 1996



**PARSONS
ENGINEERING SCIENCE, INC.**

8000 Centre Park Drive, Suite 200 • Austin, Texas 78754

AQ M01-03-0584

DEFENSE TECHNICAL INFORMATION CENTER
REQUEST FOR SCIENTIFIC AND TECHNICAL REPORTS

Title AFCEE Collection

1. Report Availability (Please check one box) <input checked="" type="checkbox"/> This report is available. Complete sections 2a - 2f. <input type="checkbox"/> This report is not available. Complete section 3.	2a. Number of Copies Forwarded <u>1 each</u>	2b. Forwarding Date <u>July/2000</u>
--	--	--

2c. Distribution Statement (Please check ONE box)
 DoD Directive 5230.24, "Distribution Statements on Technical Documents," 18 Mar 87, contains seven distribution statements, as described briefly below. Technical documents MUST be assigned a distribution statement.

DISTRIBUTION STATEMENT A: Approved for public release. Distribution is unlimited.

DISTRIBUTION STATEMENT B: Distribution authorized to U.S. Government Agencies only.

DISTRIBUTION STATEMENT C: Distribution authorized to U.S. Government Agencies and their contractors.

DISTRIBUTION STATEMENT D: Distribution authorized to U.S. Department of Defense (DoD) and U.S. DoD contractors only.

DISTRIBUTION STATEMENT E: Distribution authorized to U.S. Department of Defense (DoD) components only.

DISTRIBUTION STATEMENT F: Further dissemination only as directed by the controlling DoD office indicated below or by higher authority.

DISTRIBUTION STATEMENT X: Distribution authorized to U.S. Government agencies and private individuals or enterprises eligible to obtain export-controlled technical data in accordance with DoD Directive 5230.25, Withholding of Unclassified Technical Data from Public Disclosure, 6 Nov 84.

2d. Reason For the Above Distribution Statement (in accordance with DoD Directive 5230.24)

2e. Controlling Office <u>HQ AFCEE</u>	2f. Date of Distribution Statement Determination <u>15 Nov 2000</u>
--	---

3. This report is NOT forwarded for the following reasons. (Please check appropriate box)

It was previously forwarded to DTIC on _____ (date) and the AD number is _____

It will be published at a later date. Enter approximate date if known. _____

In accordance with the provisions of DoD Directive 3200.12, the requested document is not supplied because:

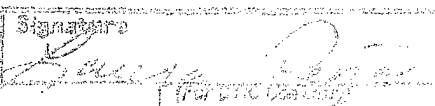
Print or Type Name <u>Laura Peña</u> Telephone <u>210-536-1431</u>	Signature  AD Number <u>MOI-03-0584</u>
---	--

**BIOVENTING BLOWER SYSTEM
OPERATIONS AND MAINTENANCE MANUAL
LPST NO. 98505, BUILDING 675
FORT BLISS, TEXAS**

Prepared for:

**The U.S. Army Environmental Center
Aberdeen Proving Ground, Maryland**

**Fort Bliss
El Paso, Texas**

and

**Air Force Center for Environmental Excellence
Brooks Air Force Base
San Antonio, Texas**

May, 1996

CONTENTS

	<u>Page</u>
SECTION 1 INTRODUCTION.....	1-1
SECTION 2 BLOWER SYSTEM CONFIGURATION SUMMARY.....	2-1
SECTION 3 BIOVENTING SYSTEM OPERATION.....	3-1
3.1 PRINCIPLE OF OPERATION.....	3-1
3.2 SYSTEM DESCRIPTION.....	3-1
3.2.1 Blower System.....	3-1
3.2.2 Monitoring Gauges.....	3-1
SECTION 4 SYSTEM MAINTENANCE.....	4-1
4.1 BLOWER/MOTOR.....	4-1
4.2 AIR FILTER.....	4-1
4.3 MAINTENANCE SCHEDULE.....	4-2
4.4 MAJOR REPAIRS.....	4-2
SECTION 5 SYSTEM MONITORING.....	5-1
5.1 BLOWER PERFORMANCE MONITORING.....	5-1
5.1.1 Vacuum/Pressure.....	5-1
5.1.2 Flow Rate.....	5-1
5.1.3 Temperature.....	5-1
5.3 MONITORING SCHEDULE.....	5-1
APPENDIX A REGENERATIVE BLOWER INFORMATION	
APPENDIX B DATA COLLECTION SHEET	

FIGURES

	<u>Page</u>
3.1 As Built Blower System Instrumentation Diagram for Air Injection.....	3-2

SECTION 1 INTRODUCTION

This document has been prepared by Parsons Engineering Science, Inc. (Parsons ES) to support the extended bioventing initiative contract awarded by the Air Force Center for Environmental Excellence (AFCEE). The document was prepared for the performance of an extended bioventing pilot test at LPST no. 98508, Building 675, Fort Bliss, El Paso.

The bioventing system was installed upon completion of the initial bioventing pilot test for the purpose of extended pilot testing. This system will operate for a 1-year period to provide further information as to the feasibility of the technology at the site, and to provide interim remedial action.

This Operations and Maintenance Manual has been created specifically for sites at which regenerative blowers have been installed for extended pilot testing. Basic maintenance of these systems is the responsibility of the Fort Bliss facility. This manual is to be used by facility personnel to guide and assist them in operating and maintaining the blower system. Section 2 provides a summary of the bioventing system components installed. Section 3 describes the blower system. Section 4 details the maintenance requirements and provides maintenance schedules. Section 5 describes the system monitoring that is required to forecast system maintenance needs and to provide data for the extended pilot test. Blower performance curves and relevant service information for regenerative blowers are provided in Appendix A, and a data collection sheet is provided in Appendix B.

SECTION 2
BLOWER SYSTEM CONFIGURATION SUMMARY

System Type: Injection

Blower: Regenerative

Blower Model: GAST, R4110N-50

Motor (Hp): 1

Inlet Vacuum Gauge (range): 0 - 60" of H₂O

Inlet Filter (part no.): AJ 134E

Outlet Temperature Gauge (range): 0 - 250°F

Outlet Pressure Gauge (range): 0 - 100" of H₂O

Pressure Relief Valve Set @: 52" of H₂O

SECTION 3 BIOVENTING SYSTEM OPERATION

3.1 PRINCIPLE OF OPERATION

Bioventing is the forced injection of fresh air to enhance the supply of oxygen for stimulating aerobic *in situ* bioremediation. A regenerative pressure (air injection) blower unit is used to inject air into the soil, thereby supplying fresh air with approximately 20.8 percent oxygen to the contaminated soils. Once oxygen is provided to the subsurface, existing bacteria will continue the breakdown of fuel residuals by aerobic respiration instead of anaerobic bioremediation, as was encountered at the site prior to beginning air injection.

3.2 SYSTEM DESCRIPTION

3.2.1 Blower System

A regenerative blower (GAST, R1140N-50) powered by a 1-horsepower direct-drive motor is the workhorse of the extended bioventing system installed at Building 675. This blower is rated at a flow rate of 92 standard cubic feet per minute (scfm) at a pressure of 51 inches of water; however, the actual performance of the blower varies with changing site conditions and desired flow rates. As installed, the blower was producing an estimated flow rate of 16.5 actual cfm at an injection pressure of 4 inches of water. The system includes an air filter to remove any particulates which are entrained in the air stream, and several valves and monitoring gauges which are described in the next section. A schematic of the blower instrumentation installed at Building 675 is shown in Figure 3.1. Corresponding blower performance curves, and relevant service information are provided in Appendix A.

3.2.2 Monitoring Gauges

The bioventing system is equipped with vacuum and pressure gauges, and temperature gauges. Gauges have been installed on the system at the following locations: a vacuum gauge in the inlet piping and a pressure gauge in the outlet piping. In addition, a temperature gauge is provided in the discharge piping. The as-built drawing shows the locations of the gauges installed on the blower systems at these sites. Temperature gauges may be located at the inlet and outlet of the blower system. These gauges are used to monitor the inlet and outlet temperature to determine the change in temperature across the blower. For the Building 675 LPST site system, ambient air temperature should be used to determine the inlet temperature.

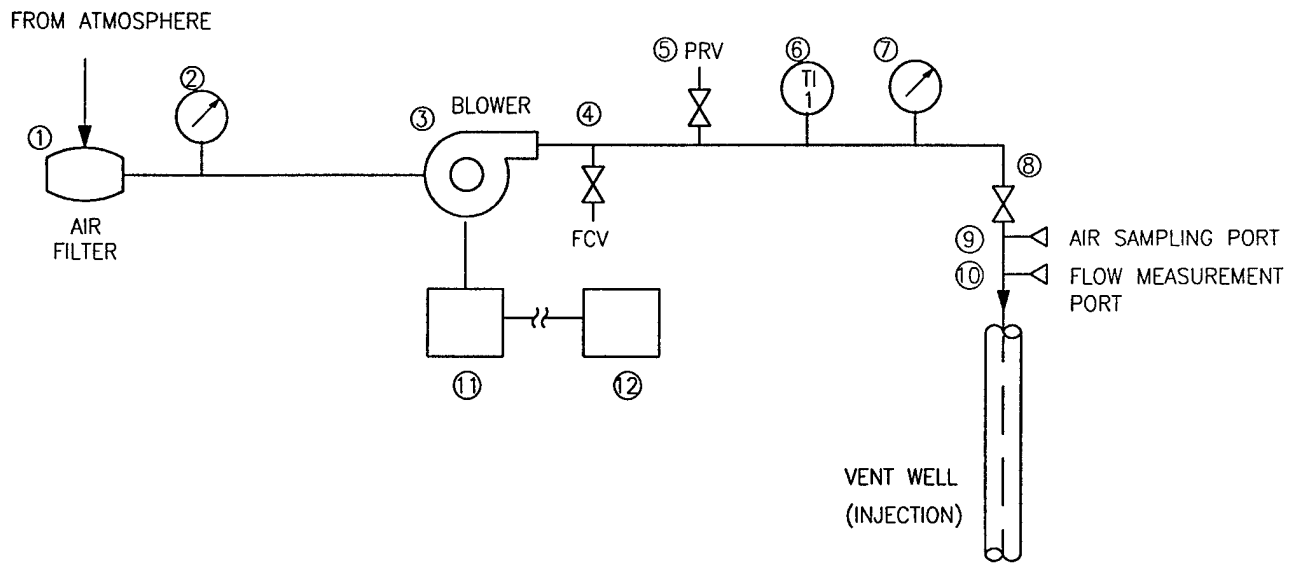

LEGEND

- ① INLET AIR FILTER - SOLBERG® AJ 134E
- ② VACUUM GAUGE (0-60 in. H₂O)
- ③ BLOWER - GAST® 1hp R4110-50
- ④ MANUAL PRESSURE RELIEF (BLEED) VALVE - 1 1/2 in. GATE
- ⑤ AUTOMATIC PRESSURE RELIEF VALVE, SET TO RELEASE AT 46 in. H₂O PRESSURE.
- ⑥ TEMPERATURE GAUGE (0-250 °F)
- ⑦ PRESSURE GAUGE (0-100 in. H₂O)
- ⑧ FLOW CONTROL GATE VALVE - 2 in. PVC
- ⑨ AIR SAMPLING PORT (3/16" HOSE BARB WITH 1/4" BALL VALVE)
- ⑩ FLOW MEASUREMENT PORT (1/4" SWAGELOK FITTING AND CAP)
- ⑪ MANMOTOR STARTER (CR1062R2B), MOUNTED IN SHED HOUSING BLOWER
- ⑫ BREAKER BOX - 208 V/SINGLE PHASE/20 A LOCATED IN BUILDING 2001.

<p>FIGURE 3.1</p> <p>AS BUILT BLOWER SYSTEM INSTRUMENTATION</p> <p>DIAGRAM FOR AIR INJECTION</p> <p>LPST NO. 98508</p> <p>FORT BLISS, TEXAS</p> <p>PARSONS ENGINEERING SCIENCE, INC.</p>
--

SECTION 4

SYSTEM MAINTENANCE

Although the motor and blower are relatively maintenance free, periodic system maintenance is required for proper operation and long life. Recommended maintenance procedures and schedules are described in detail in the instruction manuals included in Appendix A, and briefly summarized in this section.

Filter inspection must be performed with the system turned off. Typically, the manual air pressure release valve is opened when restarting the blower to protect the motor from excessive strain. This bleed valve is then slowly closed until the desired injection flow rate is obtained. With the system installed at Building 675, little resistance is provided by the formation, so no adjustments are required when restarting the blower motor.

4.1 BLOWER/MOTOR

The blower and motor are relatively maintenance free and should not require any periodic maintenance during the 1-year extended testing period. Both blower and motor have sealed bearings and do not require lubrication.

4.2 AIR FILTER

To avoid damage caused by passing solids through the blower, an air filter has been installed in-line before the blower. The filter element is paper and is accompanied by a polyurethane foam prefilter. The filter should be checked weekly for the first 2 months of operation. A facility employee should determine the best schedule for filter replacement. The polyurethane prefilters can be washed with lukewarm water and a mild detergent. Paper filter elements should never be washed, but should be disposed of and replaced as necessary. When the vacuum drop across the filter is above 15 inches of water, a dirty filter element should be suspected, and cleaning or replacement should be performed.

To remove the filter, loosen the three clamps or the wing nut, lift the metal top off the air filter, and lift the air filter from the metal housing. Remove the polyurethane prefilter (if applicable) and wash before replacing. When replacing the filter, be careful that the rubber seals remain in place.

The filter element is manufactured by Solberg Manufacturing, Inc. in Itasca, Illinois. Their telephone number is (708) 773-1363. Additional filters can also be obtained through Parsons ES. The Parsons ES contacts are Brian Vanderglas of Parsons ES Austin, and John Ratz of Parsons ES Denver. Mr. Vanderglas and Mr. Ratz can be

reached at (512) 719-6000 and (303) 831-8100, respectively. The filter model number is AJ 134E. It is recommended that the base keep at least one spare air filter at the site; a spare filter was supplied with the blower system.

4.3 MAINTENANCE SCHEDULE

The following maintenance schedule is recommended for these systems. During the initial months of operation more frequent monitoring is recommended to ensure that any startup problems are quickly corrected. A daily drive-by inspection is recommended during the initial 2 weeks of operation to ensure that the blower system is still operating with no unusual sounds. Data collection sheets that can be used to record maintenance activities is included in Appendix B.

<u>Maintenance Item</u>	<u>Maintenance Frequency</u>
Filter	Check once per month, wash or replace as necessary (see Section 4.2).

4.4 MAJOR REPAIRS

Blowers systems are very reliable when properly maintained. Occasionally, a motor or blower will develop a serious problem. If a blower system fails to start, and a qualified electrician verifies that power is available at the blower or starter, the Parsons ES site manager, Mr. Brian Vanderglas, should be called at (512) 719-6000. Parsons ES is responsible for major repairs during the first year of operation.

SECTION 5 SYSTEM MONITORING

5.1 BLOWER PERFORMANCE MONITORING

To monitor the blower performance, vacuum, pressure, and temperature will be measured. These data should be recorded weekly on a data collection sheet (provided in Appendix B). All measurements should be taken at the same time while the system is running. Because the system is loud, hearing protection may need to be worn during these measurements.

5.1.1 Vacuum/Pressure

With hearing protection in place, open the blower enclosure and record all vacuum and pressure readings directly from the gauges (in inches of water). Record the measurements on a data collection sheet (Appendix B).

5.1.2 Flow Rate

The flow rate through the vent well and soils can be estimated when the inlet vacuum and outlet pressure of the blower are known. This pressure change across the blower (vacuum + pressure) can be compared to the performance curves for the blower in Appendix A to determine the approximate flow rate. An air flow anemometer was used to optimize the air flow following completion of the bioventing pilot test.

5.1.3 Temperature

With hearing protection in place, open the blower enclosure and record the temperature readings directly from the gauge in degrees Fahrenheit (°F). Record the measurement on a data collection sheet (provided in Appendix B). The temperature change can be converted to degrees Celsius (°C) using the formula $^{\circ}\text{C} = (^{\circ}\text{F} - 32) \times 5/9$.

5.3 MONITORING SCHEDULE

The following monitoring schedule is recommended for this system. During the initial months of operation, more frequent monitoring is recommended to ensure that any start up problems are quickly corrected. Data collection sheets have been provided to assist your data collection. At the end of one year of operation, Parsons ES will return to the site to perform an annual system check and to evaluate the performance of bioventing as a treatment option.

<u>Monitoring Item</u>	<u>Monitoring Frequency</u>
Vacuum/Pressure	Daily during first week, then once every two weeks.
Temperature	Daily during first week, then once every two weeks.

APPENDIX A
REGENERATIVE BLOWER INFORMATION



Post Office Box 97
Benton Harbor, Michigan 49023-0097
Ph: 616/926-6171
Fax: 616/925-8288

Maintenance Instructions for Gast Standard Regenerative Blowers

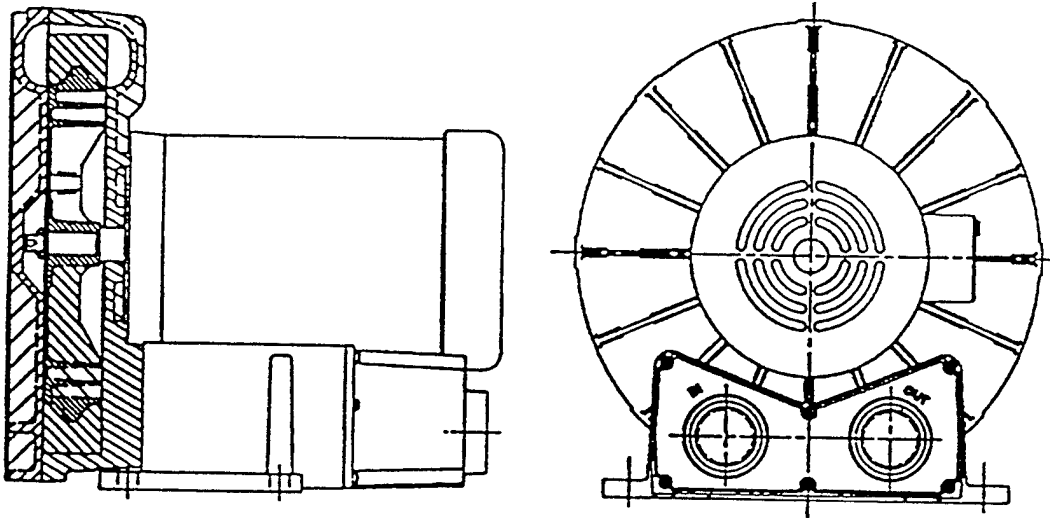

For original equipment manufacturers
special models, consult your local distributor

Gast Rebuilding Centers

Gast Mfg. Corp.
2550 Meadowbrook Rd.
Benton Harbor MI. 49022
Ph: 616/926-6171
Fax: 616/925-8288

Gast Mfg Corp.
505 Washington Avenue
Carlstadt, N. J. 07072
Ph: 201/933-8484
Fax: 201/933-5545

Brenner Fiedler. & Assoc.
13824 Bentley Place
Cerritos, CA. 90701
Ph: 213/404-2721
Fax: 213/404-7975

Wainbee, Limited
121 City View Drive
Toronto, Ont. Canada M9W 5A9
Ph: 416/243-1900
Fax: 416/243-2336

Wainbee, Limited
215 Brunswick Drive
Pointe Claire, P.Q. Canada H9R 4R7
Ph: 514/697-8810
Fax: 514/697-3070

Gast Mfg. Co. Limited.
Halifax Rd, Cressex Estate
High Wycombe, Bucks HP12 3SN
Ph. 44 494 523571
Fax: 44 494 436588

Japan Machinery Co. Ltd.
Central PO Box 1451
Tokyo 100-91 Japan
Ph: 813/3573-5421
Fax: 813/3571-7865

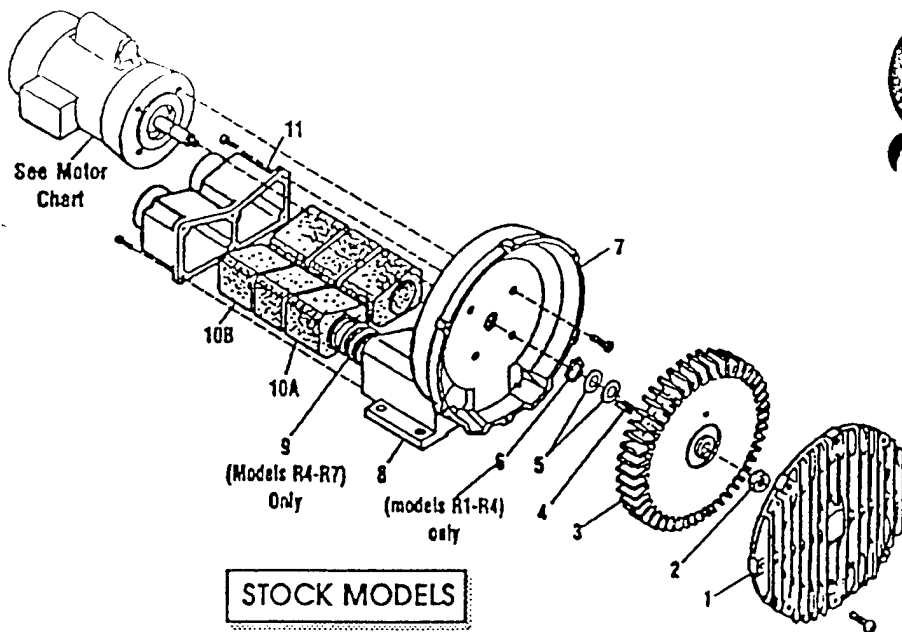

STOCK MODELS

Part Name	R1	R2	R3	R4	R5	R6	R6P	R6PP/R6PS	R7
#1 Cover	AJ101A	AJ101B	AJ101C	AJ101D	AJ101EQ	AJ101F	AJ101K	(2)AJ101KA	AJ101G
#2 Stopnut	BC187	BC187	BC181	BC181	BC181	BC181	BC181	(2)BC182	BC183
#3 Impeller	AJ102A	AJ102BQ	AJ102C	AJ102D	AJ102E	AJ102FR	AJ102K	(2)AJ102KA	AJ102GA
#4 Square Key	AH212C	AH212	AB136A	AB136D	AB136	AB136	AB136	(2)AB136	AC628
#5 Shim Spacer (s)	AJ132	AE686-3	AJ109	AJ109	AJ109	AJ116A	AJ116A	AJ116A	AJ110
#6 Retaining Ring	AJ145	AJ145	AJ149	AJ149					
#7 Housing	AJ103A	AJ103BQ	AJ103C	AJ103DR	AJ103E	AJ103F	AJ103K	AJ103KD	AJ103GA
#8 Muffler Box					AJ104E	AJ104F			
#9 Spring				AJ113DR	AJ113DQ	AJ113FQ	AJ113FQ		AJ113G
#10A Foam	(4)AJ112A	(4)AJ112B	(4)AJ112C	(4)AJ112DS	(4)AJ112ER	(6)AJ112F	(8)AJ112K		(8)AJ112GA
#10B Foam		(2)AJ112BQ	(2)AJ112CQ	(2)AJ112DR	(2)AJ112EQ				
#11 Muffler Extension/ Adapter Plate	AJ106H	AJ106BQ	AJ106CQ	AJ106DQ	AJ106EQ	AJ106EQ	AJ104K		AJ104GA
Shim Kit	K396	K396							K395

MOTOR CHART

REGENAIR MODEL NUMBER	MOTOR NUMBER	MOTOR SPECIFICATIONS		PHASE
		60 HZ VOLTS	50 HZ VOLTS	
R1102	J111X	115/208-230	110/220-240	1
R1102C	J112X	115		1
R2103	J311X	115/208-230	110/220	1
R2105	J411X	115/208-230	110/220	1
R2303A	J310	208-230/460	220/380-415	3
R2303F	J313	208-230	220	3
R3105-1/R3105-12	J411X	115/208-230	110/220-240	1
R3305A-1/R3305A-13	J410	208-230/460	220/380-415	3
R4110-2	J611AX	115/208-230	110/220-240	1
R4310A-2	J610	208-230/460	220/380-415	3
R5125-2	J811X	115/208-230		1
R5325A-2	J810X	208-230/460	220/380-415	3
R6125-2	J811X	115/208-230		1
R6325A-2	J810X	208-230/460	220/380-415	3
R6335A-2	J910X	208-230/460	220/380-415	3
R6150J-2	J1013	230		1
R6350A-2	J1010	208-230/460	220/380-415	3
R6P335A	J910X	208-230/460	220/380-415	3
R6P350A	J1010	208-230/460	220/380-415	3
R6P355A	J1110A	208-230/460	220/380-415	3
R7100A-2*	J1210B	208-230/460	220/380-415	3
R6PP/R6PS3110M	JD1100	208-230/460	220/380-415	3

* No lubrication needed at start up. Bearings lubricated at factory.

* Motor is equipped with alemite fitting. Clean tip of fitting and apply grease gun. Use 1 to 2 strokes of high quality ball bearing grease.

Consistency	Type	Typical Grease
Medium	Uthium	Shell Dolum R

Hours of service per year

5,000

Continual Normal Application

Seasonal service motor idle for 6 months or more

Continuous-high ambient, dirty or moist applications.

Suggested Relube Interval

3 years

1 year beginning of season
6 months

All performance figures relate to stock models. A few high pressure units may be available. Consult your local distributor.

Regenair Model Number	PRESSURE						Maximum Pressure "H ₂ O"
	0"H ₂ O	20"H ₂ O	40"H ₂ O	60"H ₂ O	80"H ₂ O	100"H ₂ O	
R1	26	14					28
R2	42	26					38
R3105-1	52	38	14				42
R3105-12	52	36	23				55
R3305A-13	52	36	23				55
R4	90	70	50				52
R5	145	130	100				65
R6125-2	200	180					35
R6325A-2	200	180	152				40
R6335A-2	205	175	155	135			70
R6350A-2	200	180	150	130	110	80	105
R6P335A	290	250					30
R6P350A	300	260	230	200			60
R6P355A	300	260	230	200	160		90
R7100A-2	420	380	340	310	280	230	115
R6PP311OM	485	452	420	380	330		95
R6PS311OM	265	258	252	244	236	226	170

Regenair Model Number	VACUUM					Maximum Vacuum "H ₂ O"
	0"H ₂ O	20"H ₂ O	40"H ₂ O	60"H ₂ O	80"H ₂ O	
R1	25	14				26
R2	40	22				34
R3105-1	50	34	9			40
R3105-12	51	34	20			50
R3305A-13	51	34	20			50
R4	82	62	39			48
R5	140	115	90	50		60
R6125-2	190	155	125			45
R6325A-2	190	155	125			45
R6335A-2	190	150	125	100		75
R6350A-2	190	180	150	100	70	90
R6P335A	270	230				37
R6P350A	280	240	210	170		70
R6P355A	280	240	210	170	100	86
R7100A-2	410	350	300	250	170	90
R6PP311OM	470	425	375	320	220	80
R6PS311OM	240	225	210	195	175	130

*This number indicates the maximum static pressure differential recommended (with cooling air still flowing through unit). In general, units 1hp or less can be dead headed. Check with local representative or distributor to verify which models apply.

Operation of the blower above the recommended maximum duty will cause premature failure due to the build up of heat damaging the components.

Performance data was determined under the following conditions:

- 1) Unit in a temperature stable condition.
- 2) Test conditions: Inlet air density at 0.075lbs. per cubic foot. (20°C(68°F), 29.92 in. Hg(14.7PSIA)).
- 3) Normal performance variations on the resistance curve within +/- 10% of supplied data can be expected.
- 4) Specifications subject to change without notice.
- 5) All performance at 60Hz operation.



Z10103
F2-205/8/92
AK811 Rev. E

Post Office Box 97
Benton Harbor, MI. 49023-0097
Ph: 616/926-6171
Fax: 616/925-8288

INSTALLATION AND OPERATING INSTRUCTIONS FOR GAST HAZARDOUS DUTY REGENAIR BLOWERS

This instruction applies to the following models ONLY: R3105N-50, R4110N-50, R4310P-50, R4P115N-50, R5125Q-50, R5325R-50, R6130Q-50, R6P155Q-50, R6350R-50, R6P355R-50 and R7100R-50.

Gast Authorized Service Facilities are Located In the locations listed below

Gast Manufacturing Corporation
505 Washington Avenue
Carlstadt, N. J. 07072
Ph: 201/933-8484
Fax: 201/933-5545

Gast Manufacturing Corporation
2550 Meadowbrook Road
Benton Harbor, MI. 49022
Ph: 616/926-6171
Fax: 616/925-8288

Brenner Fiedler & Associates
13824 Bentley Place
Cerritos, CA. 90701
Ph: 213/404-2721
Ph: 800/843-5558
Fax: 213/404-7975

Wainbee Limited
215 Brunswick Blvd.
Pointe Claire, Quebec
Canada H9R 4R7
Ph: 514/697-8810
Fax: 514/697-3070

Wainbee Limited
5789 Coopers Ave.
Mississauga, Ontario
Canada L4Z 3S6
Ph: 416/243-1900
Fax: 416/243-2336

Japan Machinery
Central PO Box 1451
Toyko 100-91, Japan
Ph: 813 3573-5421
Fax: 813 3571-7896

Gast Manufacturing Co. Ltd.
Halifax Road, Cressex Estate
High Wycombe, Bucks HP12 3SN
England
Ph: 44 494 523571
Fax: 44 494 436588

Safety

- ⚠** This is the safety alert symbol. When you see this symbol, personal injury is possible. The degree of injury is shown by the following signal words:
- ⚠ DANGER:** Severe injury or death will occur if hazard is ignored.
 - ⚠ WARNING:** Severe injury or death can occur if hazard is ignored.
 - ⚠ CAUTION:** Minor injury or property damage can occur if hazard is ignored.
- Review the following information carefully before operating.

General Information

- ⚠ DANGER:** Do not pump flammable or explosive gases or operate in an atmosphere containing them. Ambient temperature for normal operation should not exceed 40 degrees C (105 degrees F). For higher ambient operation, consult the factory. Blower performance is reduced by the lower atmospheric pressure of high altitudes. If it applies to this unit, consult a Gast distributor or the factory for details.

Installation

- ⚠ WARNING:** Electric Shock can result from bad wiring. Wiring must conform to all required safety codes and be installed by a qualified person. Grounding is required.

The Gast Regenair blower can be installed in any position. The flow of cooling air over the blower and motor must not be blocked.

PLUMBING - The threaded pipe ports are designed as connection ports only and will not support the plumbing. Be sure to use the same or larger size pipe and fittings to prevent air flow restriction and over-heating of the blower. When installing plumbing, be sure to use a small amount of pipe thread lubricant. This protects the threads in the aluminum blower housing. Dirt and chips, often found in new plumbing, should not be allowed to enter the blower.

NOISE - To reduce noise and vibration, the unit should be mounted on a solid surface that will not increase sound. The use of shock mounts or vibration isolation material is recommended. If needed, inlet or discharge noise can be reduced by attaching muffler assemblies (see accessories).

ROTATION - The Gast Regenair blower should only rotate clockwise as viewed from the electric motor side. This is marked with an arrow in the casting. Proper rotation can be confirmed by checking air flow at the IN and OUT ports. On blowers powered by a three phase motor, rotation is reversed by changing any two of the three power wires.

Operation

- ⚠ WARNING:** Solid or liquid material exiting the blower or piping can cause eye damage or skin cuts. Keep away from air stream.

- ⚠ CAUTION:** Attach blower to solid surface before starting. Prevent injury or damage from unit movement. Air containing solid particles or liquid must pass through a filter before entering the blower (see accessories list for filter suggestions). Blowers must have mufflers, filters, other accessories and all piping attached before starting. Any foreign material passing through the blower may cause internal damage.

- ⚠ CAUTION:** Outlet piping can burn skin. Guard or limit access. Mark "CAUTION Hot surface. Can cause burns." Air temperature increases when passing through the blower. When run at duties above 50 in. H₂O, metal pipe may be required for hot exhaust air.

The blower must not be operated above the limits for continuous duty. "Standard" R1, R2, R3 and R4 can operate continuously with not air flowing through the blower. Other units can only be run at the rating shown on the model number label. Do not close off inlet (for vacuum) or exhaust (for pressure) to reduce extra air flow. This could cause added heat and motor load.

ACCESSORIES - Gast pressure gauges AJ496 or AE133 and vacuum gauges AJ497 or AE134 show blower duty. The Gast pressure/vacuum relief valve, AG258, will limit the operating duty by admitting or relieving air. It also allows full flow through the blower when the relief valve closes.

Servicing

- ⚠ WARNING:** Disconnect electric power before servicing. Be sure rotating parts have stopped. Electric shock or severe cuts can result. Inlet and exhaust filters need occasional cleaning or replacement of the elements. Failure to do so will result in more pressure drop, reduced air flow and hotter operation. The outside of the unit requires cleaning of dust and dirt. The inside of the blower also may need cleaning to remove material coating the impeller and housing. If not done, the buildup can cause vibration, hotter operation and reduced flow. Noise absorbing foam in the mufflers may need replacement. **KEEP THIS INFORMATION WITH THE BLOWER. REFER TO IT FOR SAFE INSTALLATION, OPERATION OR SERVICE.**

TROUBLESHOOTING		
<i>Symptom</i>	<i>Possible Diagnosis</i>	<i>Possible Remedy</i>
Excess Vibration	Impeller damaged by foreign material Impeller contaminated by foreign material	Replace impeller Clean impeller; install adequate filtration.
Abnormal sound	Motor bearing failed Impeller rubbing against cover or housing	Replace bearings Repair Blower; check clearances.
Increase in sound	Foreign material can coat or destroy muffler foam.	Replace foam muffler elements; trap or filter foreign material.
Blown fuse	Electrical wiring problem	Have qualified person check fuse capacity and wiring.
Unit very hot	Running at too high a pressure or vacuum	Install a relief valve

OPERATING AND MAINTENANCE INSTRUCTIONS

SAFETY

This is the safety alert symbol. When you see this symbol personal injury is possible. The degree of injury is shown by the following signal words:

DANGER Severe injury or death will occur if hazard is ignored.

WARNING Severe injury or death can occur if hazard is ignored.

CAUTION Minor injury or property damage can occur if hazard is ignored.

Review the following information carefully before operating.

GENERAL INFORMATION

This instruction applies to the following models ONLY: R3105N-50, R4110N-50, R4310P-50, R4P115N-50, R5125Q-50, R5325R-50, R6130Q-50, R6P155Q-50, R6350R-50, R6P355R-50 and R7100R-50. These blowers are intended for use in Soil Vapor Extraction Systems. The blowers are sealed at the factory for very low leakage. They are powered with a U.L. listed electric motor Class 1 Div. 1 Group D motors for Hazardous Duty locations. Ambient temperature for normal full load operation should not exceed 40° C (105° F). For higher ambient operation, contact the factory.

Gast Manufacturing Corporation may offer general application guidance: however, suitability of the particular blower and/or accessories is ultimately the responsibility of the user, not the manufacturer of the blower.

INSTALLATION

DANGER Models R5325R-50, R6130Q-50, R6350R-50, R5125Q-50, R6P155Q-50, R6P355R-50 AND R7100R-50 use Pilot Duty Thermal Overload Protection. Connecting this protection to the proper control circuitry is mandated by UL674 and NEC501. Failure to do so could result in a **EXPLOSION**. See pages 3 and 4 for recommended wiring schematic for these models.

WARNING Electric shock can result from bad wiring. A qualified person must install all wiring, conforming to all required safety codes. Grounding is necessary.

WARNING This blower is intended for use on soil vapor extraction equipment. Any other use must be approved in writing by Gast Manufacturing Corp. Install this blower in any mounting position. Do not block the flow of cooling air over the blower and motor.

PLUMBING - Use the threaded pipe ports for connection only. They will not support the plumbing. Be sure to use the same or larger size pipe to prevent air flow restriction and overheating of the blower. When installing fittings, be sure to use pipe thread sealant. This protects the threads in the blower housing and prevents leakage. Dirt and chips are often found in new plumbing. Do not allow them to enter the blower.

NOISE - Mount the unit on a solid surface that will not increase the sound. This will reduce noise and vibration. We suggest the use of shock mounts or vibration isolation material for mounting.

ROTATION - The Gast Regenair Blower should only rotate clockwise as viewed from the electric motor side. The casting has an arrow showing the correct direction. Confirm the proper rotation by checking air flow at the IN and OUT ports. If needed reverse rotation of three phase motors by changing the position of any two of the power line wires.

OPERATION

WARNING Solid or liquid material exiting the blower or piping can cause eye damage or skin cuts. Keep away from air stream.

WARNING - Gast Manufacturing Corporation will not knowingly specify, design or build any blower for installation in a hazardous, combustible or explosive location without a motor conforming to the proper NEMA or U. L. standards. Blowers with standard TEFC motors should never be utilized for soil vapor extraction applications or where local state and/or Federal codes specify the use of explosion-proof motors (as defined by the National Electric Code, Articles 100,500 c1990).

CAUTION Attach blower to solid surface before starting to prevent injury or damage from unit movement. Air containing solid particles or liquid must pass through a filter before entering the blower. Blowers must have filters, other accessories and all piping attached before starting. Any foreign material passing through the blower may cause internal damage to the blower.

CAUTION Outlet piping can burn skin. Guard or limit access. Mark "CAUTION Hot Surface. Can Cause Burns". Air temperature increases when passing through the blower. When run at duties above 50 in. H₂O, metal pipe may be required for hot exhaust air. The blower must not be operated above the limits for continuous duty. Only models R3105N-50, R4110N-50 and R4310P-50 can be operated continuously with no air flowing through the blower. Other units can only be run at the rating shown on the model number label. Do not Close off inlet (for vacuum) to reduce extra air flow. This will cause added heat and motor load. Blower exhaust air in excess of 230°F indicates operation in excess of rating which can cause the blower to fail.

ACCESSORIES ...Gast pressure gauge AJ496 and vacuum gauges AJ497 or AE134 show blower duty. The Gast pressure/vacuum relief valve, AG258, will limit the operating duty by admitting or relieving air. It also allows full flow through the blower when the relief valve closes.

SERVICING

WARNING To retain their sealed construction they should be serviced by Gast authorized service centers ONLY. These models are sealed at the factory for very low leakage.

WARNING Turn off electric power before removing blower from service. Be sure rotating parts have stopped. Electric shock or severe cuts can result. Inlet and exhaust filters attached to the blower may need cleaning or replacement of the elements. Failure to do so will result in more pressure drop, reduced air flow and hotter operation of the blower.

The outside of the unit requires cleaning of dust and dirt. The inside of the blower also may need cleaning to remove foreign material coating the impeller and housing. This should be done at a Gast Authorized Service Center. This buildup can cause vibration, failure of the motor to operate or reduced flow.

KEEP THIS INFORMATION WITH THIS BLOWER. REFER TO IT FOR SAFE INSTALLATION, OPERATION OR SERVICE.

MOTOR WIRING DIAGRAM FOR R4110N-50 & R3105N-50

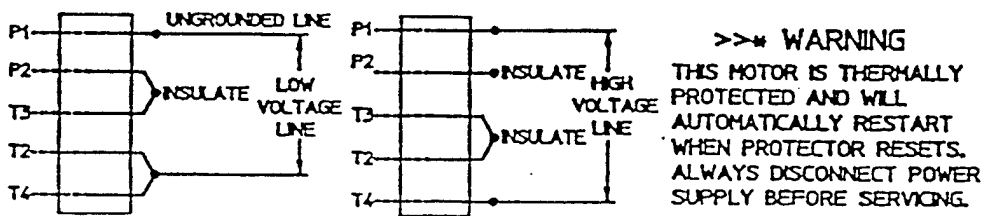

MOTORS WIRING DIAGRAM FOR R4310P-50

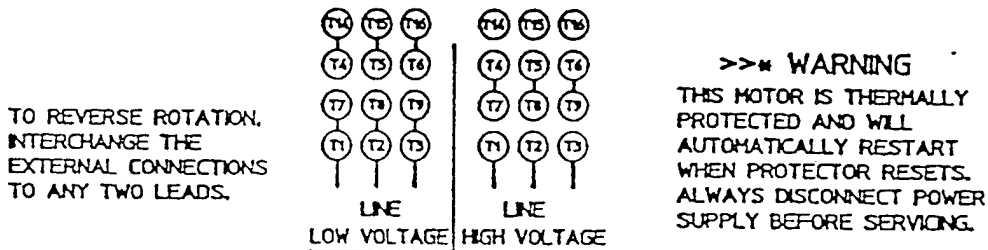

MOTORS WIRING DIAGRAM FOR R5325R-50, R6350R-50, R6P355R-50, & R7100R-50

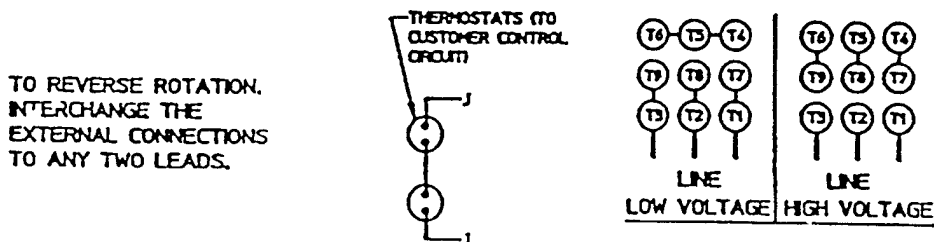

MOTOR WIRING DIAGRAM FOR R5125Q-50 & R4P115N-50

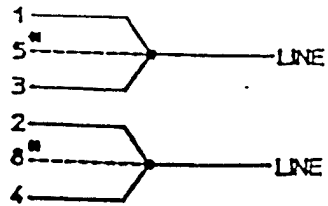

— THERMOSTAT
— THERMOSTAT

LOW VOLTAGE

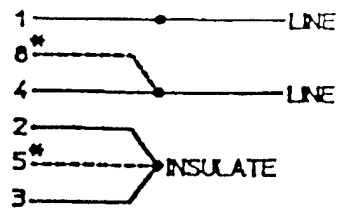

— THERMOSTAT
— THERMOSTAT

HIGH VOLTAGE

* R5125Q-50 BLOWERS PRODUCED AFTER SEPTEMBER 1992 (SER. NO. 0992) DO NOT HAVE MOTOR LEADS 5 & 8.

MOTOR WIRING DIAGRAM FOR R6130Q-50 & R6P155Q-50

CONNECT THERMOSTAT TO MOTOR PROTECTION CIRCUIT



— THERMOSTAT
— THERMOSTAT

CONNECTION FOR THERMOSTAT MOTOR PROTECTION

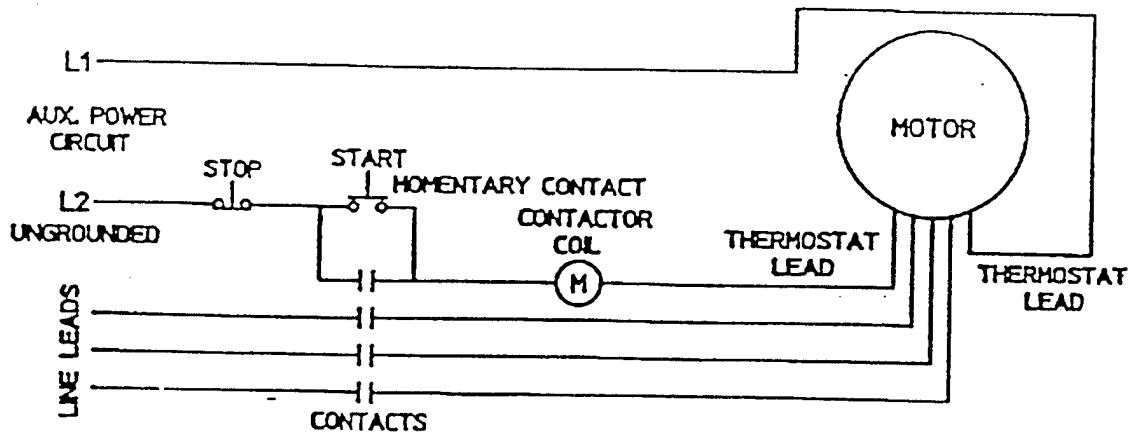

THERMOSTATS TO BE CONNECTED IN SERIES WITH CONTROL AS SHOWN. MOTOR FURNISHED WITH AUTOMATIC THERMOSTATS RATED A.C. 115-600V. 720VA

REGENAIR® R4 Series

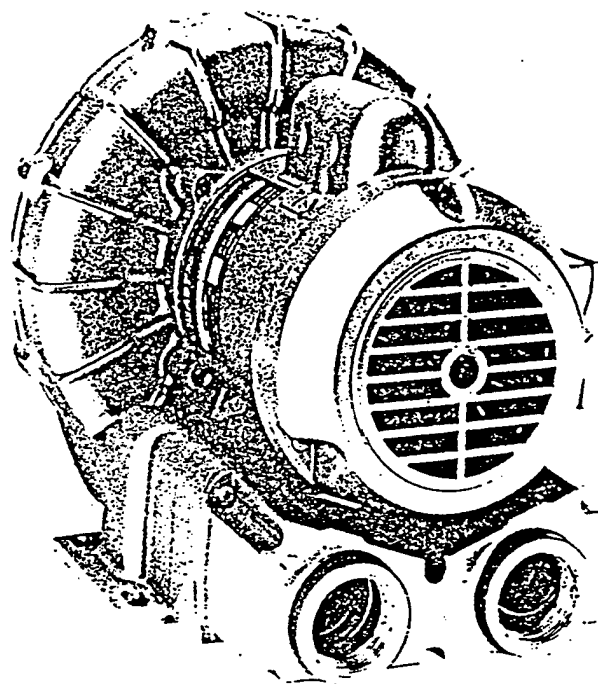

MODEL R4110-2
52" H₂O MAX. PRESSURE, 92 CFM OPEN FLOW

PRODUCT FEATURES

- Oilless operation
- TEFC motor mounted
- Can be mounted in any plane
- Rugged construction/low maintenance
- Can be operated blanked-off

COMMON MOTOR OPTIONS

- 115/208-230V, 60 Hz; 110/220-240V, 50 Hz, single phase
- 208-230/460V, 60 Hz; 190-230/380-415V, 50 Hz, three phase
- 575V, 60 Hz, three phase

RECOMMENDED ACCESSORIES

- Pressure gauge AJ496
- Filter AG338
- Muffler AJ121D
- Relief valve AG258

Various brand name motors are used on any model at the discretion of Gast Mfg. Corp.

Important Notice:

Pictorial and dimensional data is subject to change without notice.

Product Dimensions Metric (mm) U.S. Imperial (inches)

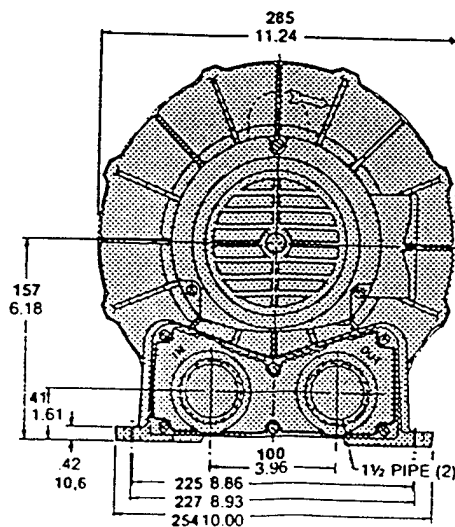
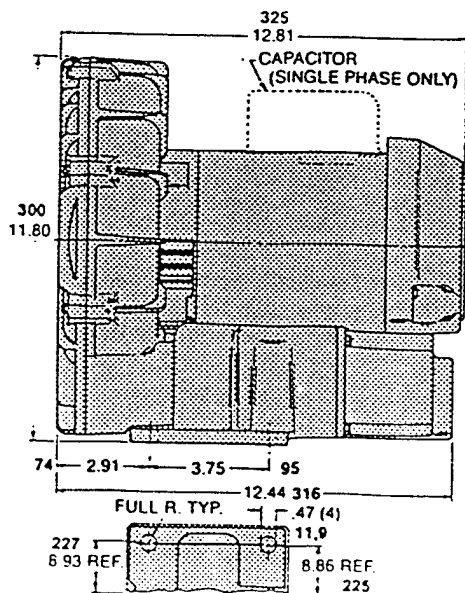

Product Specifications

Model Number	Motor Specs	Full Load Amps	HP	RPM	Max Pressure		Max Flow		Net Wt.	
					"H ₂ O	mbar	cfm	m ³ /h	lbs.	kg
R4110-2	110/220-240-50-1	9.0/4.5-5.7	0.6	2850	38	95	74	126	41	18,6
	115/208-230-60-1	9.8/5.2-4.9	1.0	3450	52	130	92	156		
R4310A-2	190-220/380-415-50-3	2.6-3.3/1.3-1.4	0.6	2850	38	95	74	126	41	18,6
	208-230/460-60-3	3.4-3.2/1.6	1.0	3450	52	130	92	156		

Product Performance (Metric U.S. Imperial) Black line on curve is for 60 cycle performance.
 Blue line on curve is for 50 cycle performance.

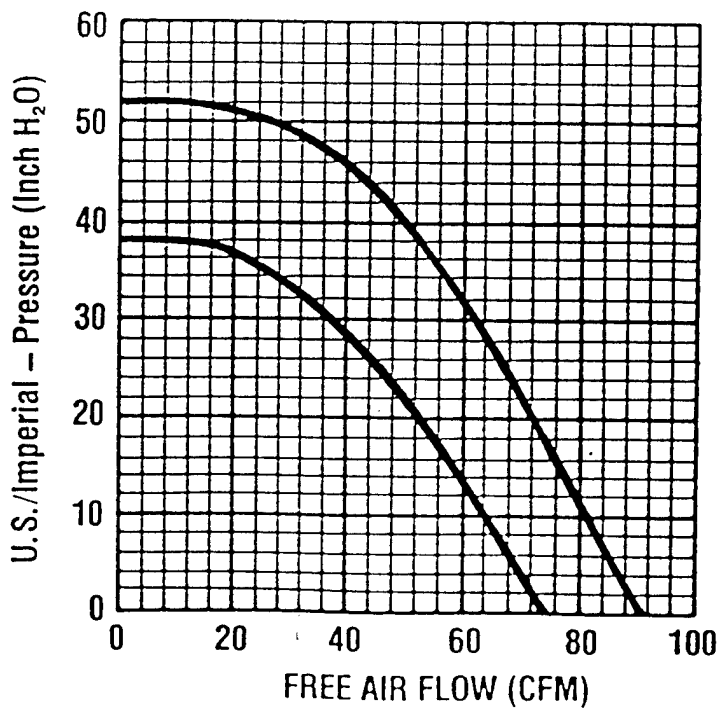
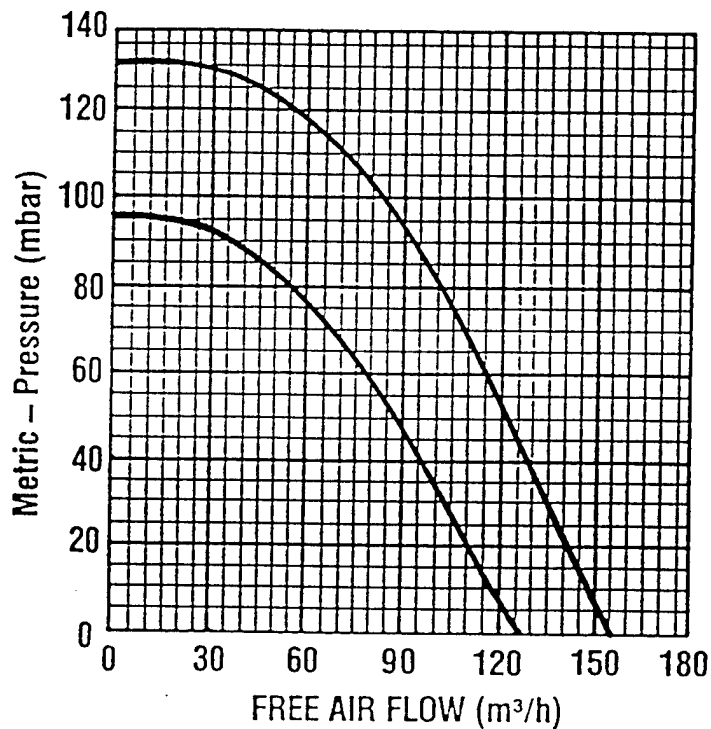

REGENAIR® R5 Series

PRESSURE

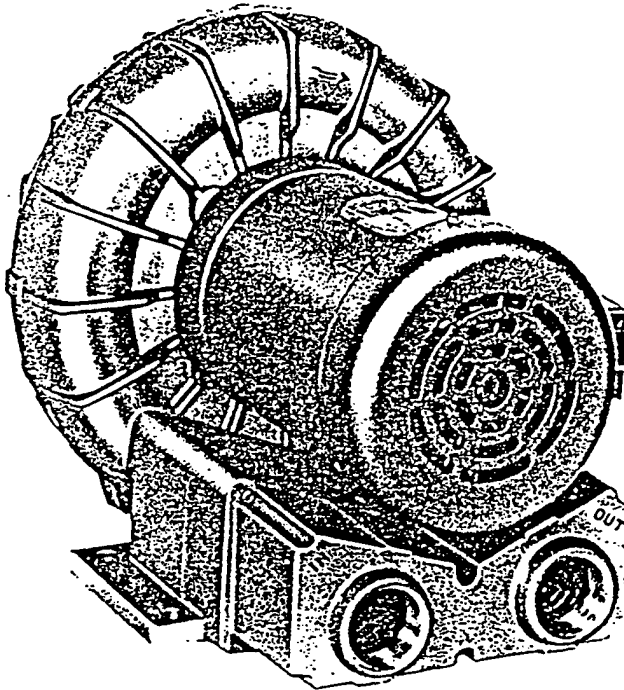

MODEL R5325A-2
65" H₂O MAX. PRESSURE, 160 CFM OPEN FLOW

PRODUCT FEATURES

- Oilless operation
- TEFC motor mounted
- Can be mounted in any plane
- Rugged construction/low maintenance

COMMON MOTOR OPTIONS

- 115/208-230V, 60 Hz, single phase
- 208-230/460V, 60 Hz; 190-220/380-415V, 50 Hz, three phase
- 575V, 60 Hz, three phase

RECOMMENDED ACCESSORIES

- Pressure gauge AE133
- Filter AG338
- Muffler AJ121D
- Relief valve AG258

Various brand name motors are used on any model at the discretion of Gast Mfg. Corp.

Important Notice:

Pictorial and dimensional data is subject to change without notice.

Product Dimensions Metric (mm) U.S. Imperial (inches)

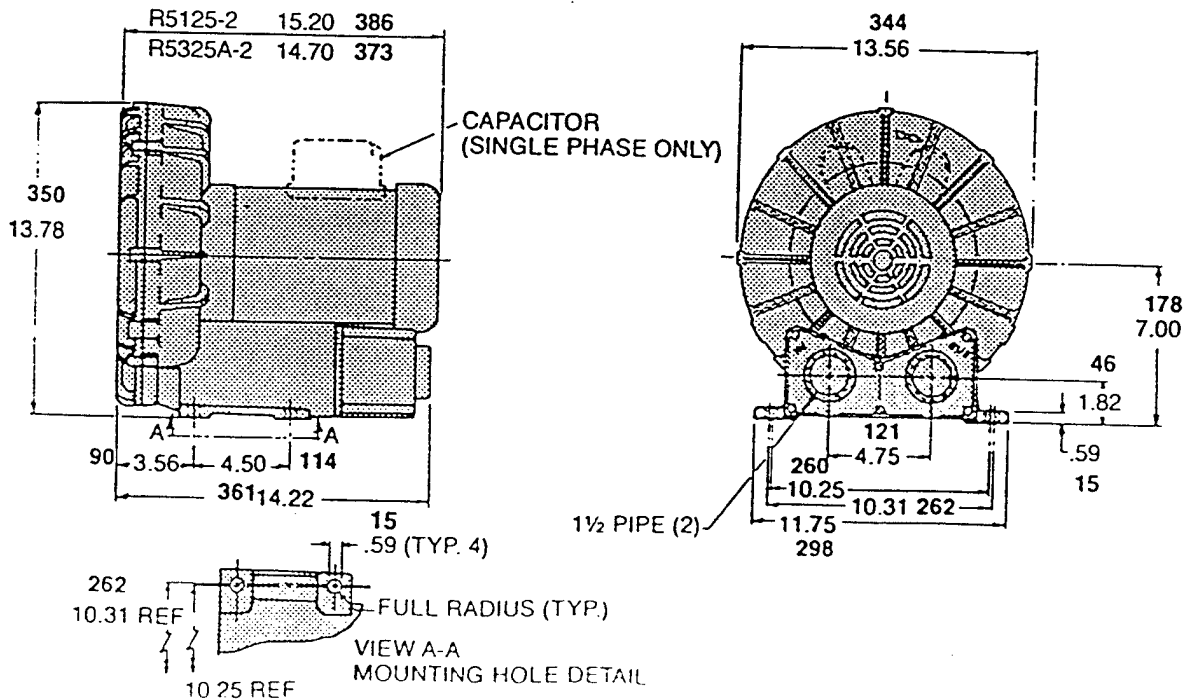

Product Specifications

Model Number	Motor Specs	Full Load Amps	HP	RPM	Max Pressure		Max Flow		Net Wt.	
					"H ₂ O	mbar	cfm	m ³ /h	lbs.	kg
R5325A-2	190-220/380-415-50-3	6.6-6.7/3.3-3.5	1.35	2850	50	125	133	226	65	29,5
	208-230/460-3	6.9/3.45	2.5	3450	65	162	160	272		
R5125-2	115/208-230-60-1	22.4/12.4-11.2	2.5	3450	60	149	160	272	73	33,1

Product Performance (Metric U.S. Imperial)

Black line on curve is for 60 cycle performance.
Blue line on curve is for 50 cycle performance.

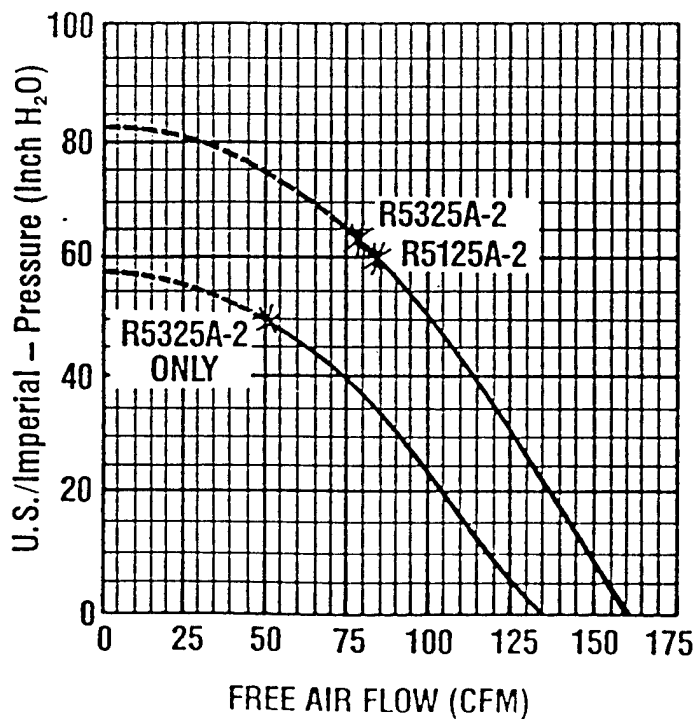
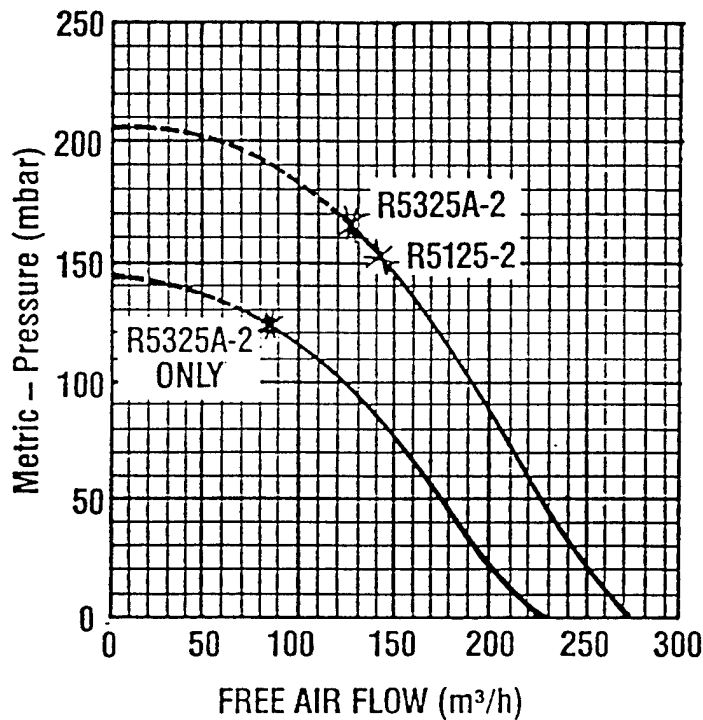

*Recommended maximum duty.
---- Intermittent duty only.

Model Number	Hz	Motor Specs	HP	RPM	Max Vac		Max Flow		Net Wt.	
					"H ₂ O	mbar	cfm	m ³ /h	lbs.	kg
R4110N-50	50	110/220-240-50-1	0.6	2850	35	924	72	122	60	28
	60	115/208-230-60-1	1.0	3450	48	895	88	150	60	28
R4310P-50	50	220/380-50-3*	0.6	2850	35	924	72	122	58	27
	60	208-230/460-60-3*	1.0	3450	48	895	88	150	58	27
R5125Q-50	60	115/230-60-1*	2.5	3450	60	865	145	246	77	35
R5325R-50	50	190-220/380-415-50-3*	1.85	2850	47	897	120	204	75	34
	60	208-230/460-60-3*	2.50	3450	60	865	145	246	75	34
R6P355R-50	50	190-220/380-415-50-3*	4.5	2850	70	840	235	400	247	112
	60	208-230/460-60-3*	6.0	3450	90	790	260	442	247	112

*Motors do not have thermal protection with automatic reset.

Product Performance (Metric U.S. Imperial)

Model R4 Series

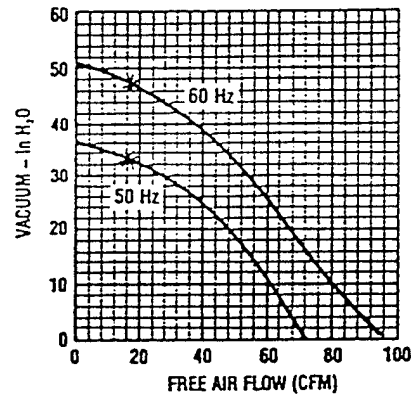
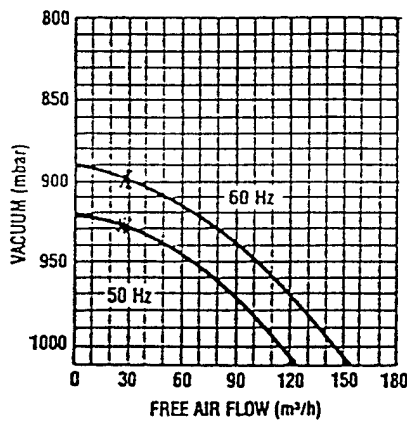

Model R5 Series

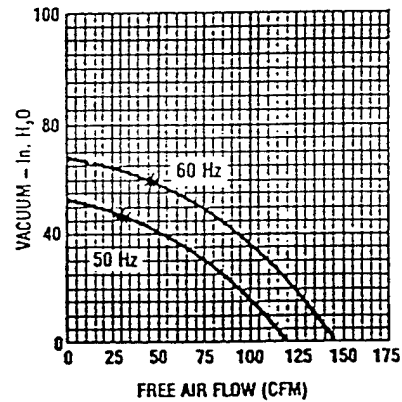
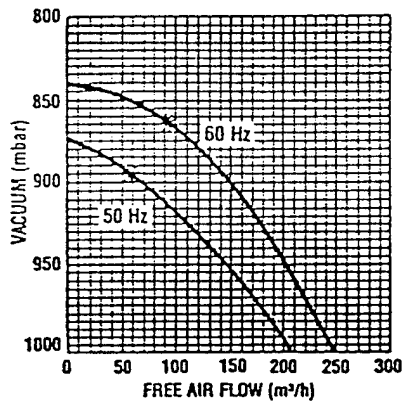

Model R6P Series

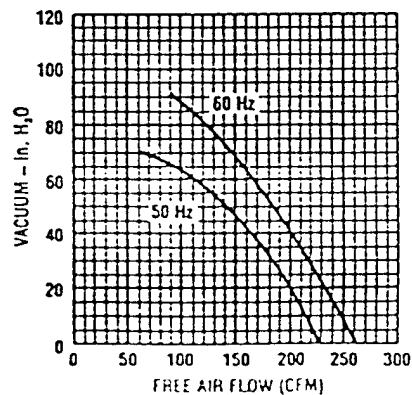
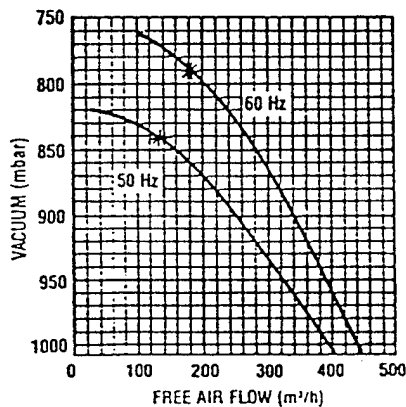

*Minimum flow permissible through the unit for trouble-free, continuous operation.

REGENAIR ACCESSORIES

Inline Filters (for vacuum)

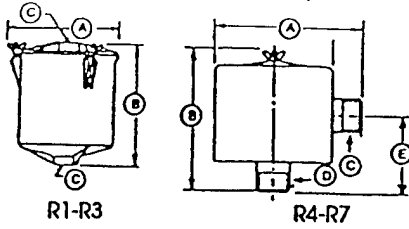

Model Number	R1 & R2	R3	R4, R5 & SDR4	R6P SDR5, SDR6 R6PP, R6PS	R7
Part #	AV460	AV460C	AG337	AJ151G	AJ151H
Dim A	8.25"	8.25"	11.75"	8.00"	16.25"
Dim B	8.875"	8.875"	4.75"	10.25"	27.13"
Dim C	1" FPT	1 1/4" FPT	1 1/2" MPT	2 1/2" MPT	3" MPT
Dim D	-	-	1 1/2" FPT	2 1/2" MPT	3" MPT
Dim E	-	-	2.38	5.50	18.50
Replacement Element	AV469	AV469	AG340	AJ135G	AJ135C
Micron	10	10	25	10	10

MPT = Male Pipe Thread
FPT = Female Pipe Thread

Mufflers

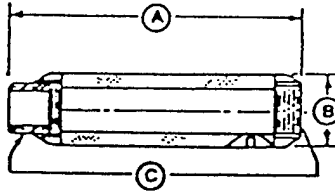

Model Number	R2	R3	R4, R5 SDR 4" & SDR5"	R6, SDR6" R6P R6PP, R6PS	R7
Part #	AJ121B	AJ121C	AJ121D	AJ121E	AJ121G
Dim. A	7.46**	7.94**	12.75**	17.05**	17.44**
Dim. B	2.38"	2.62"	3.25"	3.63"	4.25"
Dim. C	1" NPT	1 1/4" NPT	1 1/2" NPT	2" NPT	2 1/2" NPT

* For Inlet Only
** Approximately

Fittings

Pipe Size	1"	1 1/4"	1 1/2"	2"	2 1/2"
Tee Common	BA415	BA431	BA432	BA433	BA434
Elbow	BA220	BA244	BA230	BA247	BA248
Nipple	BA752	BA809	BA783	BA810	BA813
Plastic Male Pipe Hose Barb	AJ117A	AJ117B	-	-	-
Hose I.D.	1.25	1.25	-	-	-
Metal Male Pipe Hose Barb	AJ117D	AJ117F	AJ117C	AJ117G	AJ117H
Hose I.D.	1.00	1.25	1.50	2.50	3.00

Horizontal Swing Type Check Valve

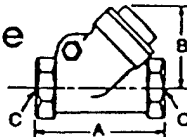

Model Number	R1, R2	R3	R4, R5 SDR 4 & SDR5	R6, SDR6 R6P R6PP, R6PS	R7
Part #	AH326B	AH326C	AH326D	AH326F	AH326G
Dim. A	3.57	4.19	4.50	5.25	8
Dim. B	2.32	2.69	2.94	3.82	5.07
Dim. C	1" NPT	1 1/4" NPT	1 1/2" NPT	2" NPT	2 1/2" NPT

Inlet Filters (for pressure units only)

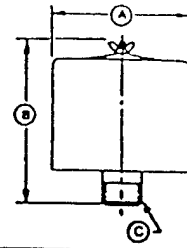

Model Number	R1 & R2	R3	R4, R5 & SDR4	R6, SDR5 SDR6, R6P R6PP, R6PS	R7
Part #	AJ126B	AJ126C	AG338	AJ126F	AJ126G
Dim A	6.00"	6.00"	10.63"	10.63"	10.00"
Dim B	4.62**	7.12**	4.81**	4.81**	13.12**
Dim C	1" MPT	1 1/4" MPT	1 1/2" FPT	2" FPT	2 1/2" MPT
Replacement Element	AJ134B	AJ134C	AG340	AG340	AJ135A
Micron	10	10	25	25	10

All are heavy duty for high amounts of particulates. Inlet filters for REGENAIR blowers are drip-proof when mounted as shown.

Pressure-Vacuum Gauge



Pressure Gauge, Part #AJ496, 2 5/8" Diameter, 1/4" NPT, 0-60 Inches H₂O and 0-150 mbar

Pressure Gauge, Part #AE133A, 2 5/8" Diameter, 1/4" NPT, 0-200 Inches H₂O and 0-500 mbar

Vacuum Gauge, Part #AJ497, 2 5/8" Diameter, 1/4" NPT, 0-60 Inches H₂O and 0-150 mbar

Vacuum Gauge, Part #AE134, 2 5/8" Diameter, 1/4" NPT, 0-160 Inches H₂O and 0-400 mbar

Relief Valve

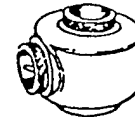

Pressure/Vacuum Relief Valve, Part #AG258, 1 1/2" NPT, Adjustable 30-170 Inches H₂O, 200 CFM maximum

Silencer for Relief Valve, Part #AJ121D



MANUFACTURING CORPORATION
P. O. BOX 97, BENTON HARBOR, MICHIGAN 49022
PHONE 616-926-6171

G360PL
7/83

**PARTS LIST and OPERATING
INSTRUCTIONS
1067, 2067, and 2567**

**OIL LESS
VACUUM PUMPS
and
COMPRESSORS**

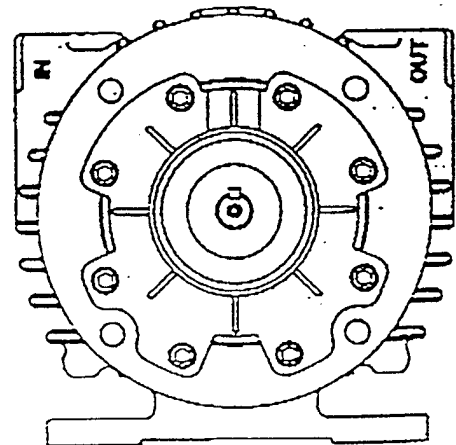
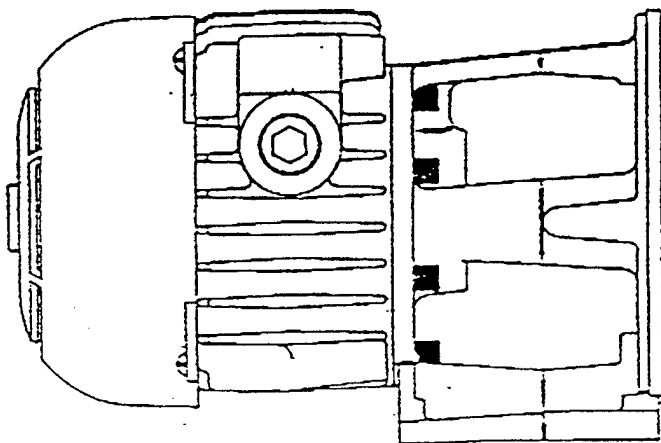

**WARNING: UNIT SHOULD NOT PUMP EXPLOSIVE GASES OR
BE USED IN EXPLOSIVE AMBIENTS.**

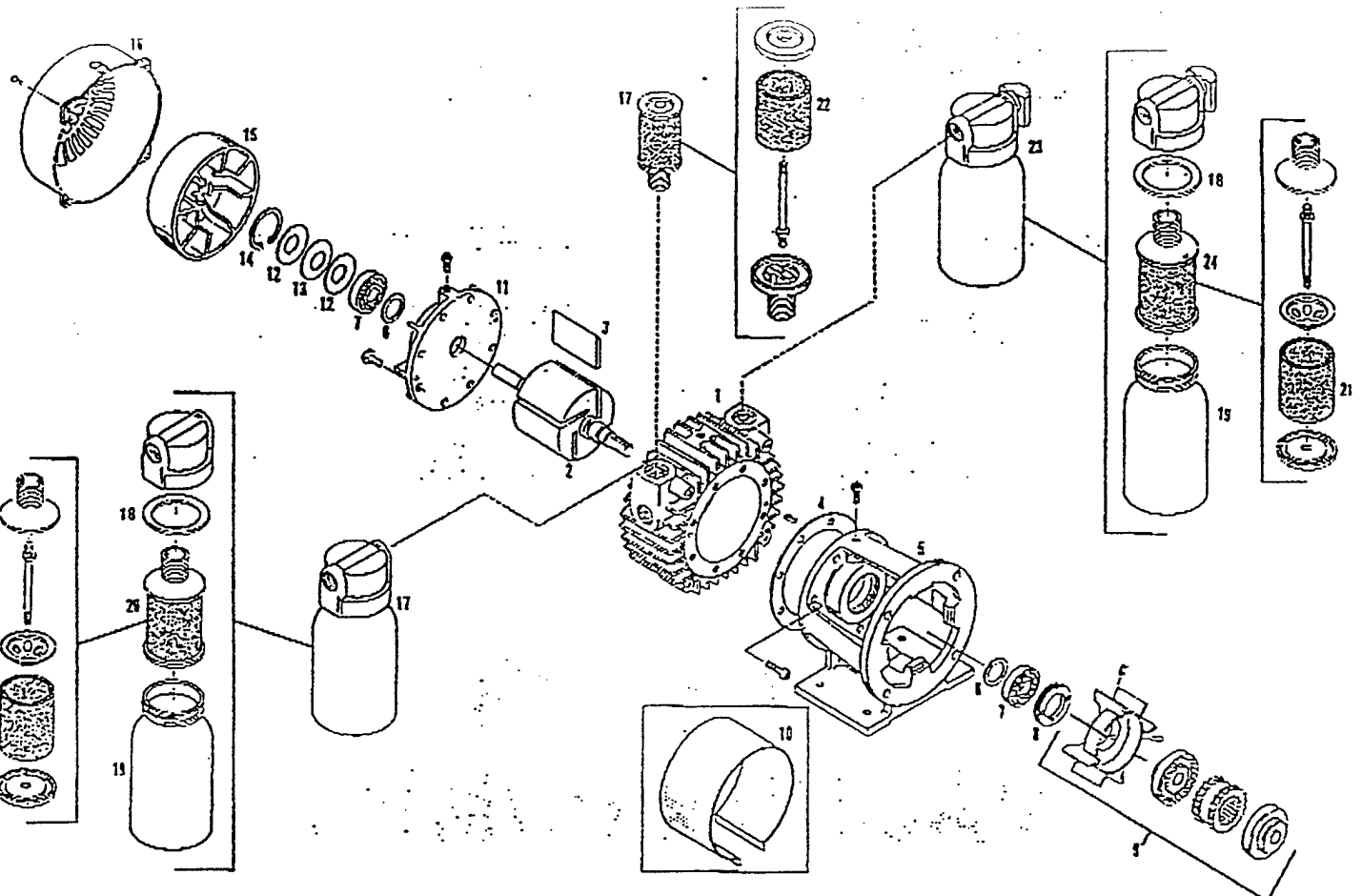

REF. NO.	DESCRIPTION	PART. QNTY.	1067-V100	1067-P102	2067-V100	2067-P102	2567-V100	2567-P102
1	Body	1	AH346	AH346	AH197	AH197	AH206	AH355
2	Rotor Assembly	1	AH428	AH428	AH192	AH192	AH192	AH192
3	Vane	4	AH430	AH430	AH196	AH196	AH196	AH196
4	Body Gasket	1	AH567	AH367	AH567	AH567	AH567	AH567
5	Foot Bracket	1	AH208	AH208	AH208	AH208	AH208	AH208
6	Deflector	2	AH193	AH193	AH193	AH193	AH193	AH193
7	Ball Bearing (Drive & Dead)	2	AC894	AC894	AC894	AC894	AC894	AC894
8	End Cap, Drive	1	AB339A	AB339A	AB339A	AB339A	AB339A	AB339A
9	Fan Coupling Assembly	1	AH198	AH198	AH198	AH198	AH198	AH198
10	Fan Guard	1	AH194	AH194	AH194	AH194	AH194	AH194
11	End Plate Dead	1	AH205	AH205	AH205	AH205	AH205	AH205
12	Belleville Springs	2	AB337	AB337	AB337	AB337	AB337	AB337
13	Washer	1	AB338	AB338	AB338	AB338	AB338	AB338
14	Snap Ring	1	AB336	AB336	AB336	AB336	AB336	AB336
16	Fan	1	AC326B	AC326B	AC326B	AC326B	AC326B	AC326B
18	Fan Guard	1	AC102B	AC102B	AC102B	AC102B	AC102B	AC102B
17	Intake Filter Assembly	1	AA900C	AA905F	AA900D	AA905G	AA900D	AA905G
18	Gasket	2	AA405		AA405		AA405	
19	Jar	2	AA401		AA401		AA401	
20	Filter Assembly	1	AC435-1		AC435-1		AC435-1	
21	Cartridge	2	AC393	AC393	AC393		AC393	
22	Filter Felt	1		D364B		D364B		D364B
23	Muffler	1	AA900F		AA900F		AA900F	
24	Muffler Assembly	1	AC436-1		AC436-1		AC436-1	
	Service Kit		K356	K356	K356	K357	K360	K357

* Denotes parts in service kit.
When corresponding or ordering spare parts, please give complete model and serial numbers.

OPERATING AND MAINTENANCE INSTRUCTIONS

CONSTRUCTION: The end plate, body, rotor and foot bracket are all cast iron. Consequently any moisture that accumulates in the pump will tend to corrode the interior especially if it stands idle. The vanes are made of hard carbon and are precision ground. They should last 5,000 to 10,000 hours depending upon the degree of vacuum pressure at which the pump is run.

STARTING: CAUTION: NEVER LUBRICATE THIS OILLESS AIR PUMP. The carbon vanes and grease packed motor bearings require no oil. If the motor fails to start or slows down when under load shut the unit off and unplug. Check that the supply voltage agrees with the motor post terminals and the motor data name plate. **CAUTION: ALL DUAL VOLTAGE MOTORS ARE SHIPPED FROM THE FACTORY WIRED FOR THE HIGH VOLTAGE.** If the pump is extremely cold allow it to warm to room temperature before starting. If anything appears to be wrong with the motor return the complete pump to an authorized Gast service facility.

To minimize noise and vibration the unit should be mounted on a solid surface that will not resonate. Use of shock mounts or vibration isolation material is recommended. Inlet or discharge noise can be minimized by attaching the muffler. The unit should not be allowed to operate in ambient air temperatures in excess of 40°C (104°F). If the motor fails to start or slows down when under load shut the unit off and unplug. Check that the supply voltage agrees with the motor post terminal setup and the motor data name plate.

FILTRATION: Care must be taken to insure that any particles (dirt, chips, foreign material) often found in new plumbing not be allowed to enter the unit. Liquid, moisture vapor, or oil based contaminants will affect pump performance and must be filtered from entering the pump.

Dirty filters restrict air flow and if not corrected could lead to possible motor overload, poor performance and early pump failure. Check filters periodically and clean when necessary by removing felts and washing in Gast flushing solvent (part number AH255). Dry with compressed air and replace.

FLUSHING: Should excessive dirt, foreign particles, moisture, or oil be permitted to enter the pump the vanes

will act sluggish or even break. Flushing the pump should remove these materials. First remove the filter & muffler clean with solvent & dry with compressed air.

DISASSEMBLY: Begin by removing the fan guard and fan. The dead end plate may be removed using a wheel puller. The vanes and body area can then be inspected for damage or further cleaning. Unless scoring is visible do not remove drive end plate and top clearance will be maintained. If further repair is required remove the spanner nut before using a wheel puller to remove the drive end plate. Both bearings are a press fit on the shaft.

REASSEMBLY: First attach the drive end plate (but do not tighten bolts) and press the bearing on the shaft (be sure to properly support the inner race). If required top clearance (between rotor & body) should then be set (for 1067 models it is .0015 and for 2067 and 2567 it is .003). Now replace the dead end plate and bearing. Then the bellville springs, washer and snap ring should be replaced. With a dial indicator on the dead end shaft to show any movement, install spanner nut (with adhesive to keep from vibrating loose) until indicator moves .002-.0025. Check shaft for ease of rotation.

HAZARD PREVENTION:

WARNING: MAKE SURE THE ELECTRIC MOTOR IS PROPERLY-GROUNDED AND THE WIRING IS DONE BY A QUALIFIED ELECTRICIAN FAMILIAR WITH NEMA MG2 SAFETY STANDARDS, NATIONAL ELECTRIC CODE AND ALL LOCAL SAFETY CODES.

WARNING: THE ELECTRIC MOTOR MAY BE THERMALLY PROTECTED AND WILL AUTOMATICALLY RESTART WHEN THE PROTECTOR RESETS.

WARNING: WHEN SERVICING ALL POWER TO THE MOTOR MUST BE DE-ENERGIZED AND DISCONNECTED. ALL ROTATING COMPONENTS MUST BE AT A STAND STILL.

WARNING: DO NOT USE KEROSENE OR OTHER COMBUSTIBLE SOLVENTS OR OPERATE PUMP IN EXPLOSIVE AMBIENTS.

Performance Data

Model	Vacuum			Maximum Vacuum
	0" HG	10" HG	20" HG	
1067	8.5 CFM	5.0 CFM	2.0	26" HG
2067	16.0	9.0	3.0	27"
2567	20.0	13.0	5.0	27"

Model	Pressure			
	0 PSI	5 PSI	10 PSI	15 PSI
1067	8.5 CFM	7.5 CFM	7.0 CFM	6.5 CFM
2067	17.0	14.0	12.0	11.0
2567	21.0	19.0	17.0	16.0

Gast Manufacturing Co., Ltd.
Coronation Road, Cressex Estate
High Wycombe, Bucks HP12 3SN
England 23571
FAX 444-945-6588

Gast Manufacturing Corp.
2550 Meadowbrook Road
Benton Harbor MI 49022
616/926-6171
FAX 616-925-8288

Gast Manufacturing Corp.
505 Washington Ave.
Carlstadt NJ 07072
201/933-8484
FAX 201-933-5545

Brenner-Fiedler & Assoc.
13824 Bentley Place
Cerritos, Ca. 90701
213-404-2721
FAX 213-404-7975

Wainbee, Ltd.
121 City View Drive
Rexdale, Ontario, Canada M9W 5A9
416/243-1900
FAX 416-243-2336

Wainbee, LTD.
215 Brunswick Blvd.
Pointe Claire, Montreal
Canada H9R 4R7
514/697-8810
FAX 514-697-3070

Note: All general correspondence should be directed to Gast Mfg Corp. P.O. Box 97, Benton Harbor, MI 49022

CHECK VALVES—vacuum

AE238	1/2" NPT, male
AJ550	1/2" NPT, female
AJ550A	3/4" NPT, female

CHECK VALVES—vacuum swing

AH326A	3/4" NPT
AH326B	1" NPT

CORDS—ELECTRIC

AAB16	1/2" 1/2" hp, 115V without switch, 10 ft.
AA819	1/2" 3/4" hp, 230V without switch, 10 ft.
AA696	1/2" 1/2" hp, 115 V with switch, 10 ft.

FILTERS—no jars

AC432	3/4" female NPS, 10 m micron
AC433	1/2" male NPS, 10 m micron
AC435	3/4" male NPS, 10 micron
AA505E	3/4" female NPS, 50 micron
AA905F	1" male NPS, 50 micron
AA905G	3/4" male NPS, 50 micron
B300A	1/2" male NPS, 50 micron
B343B	1/2" male NPS, 50 micron
AD750	1" male NPS, 50 micron

FILTERS—glass jar

AA517G	1/2" NPS, 2 oz., 50 micron
AA822H	1/2" NPS, 3/4" oz., 50 micron
AD560	1" NPS, 2 qt., 50 micron
AB590	3/4" NPS, 1 pt., 10 micron
AB595D	3/4" NPS, 1 pt., 50 micron
AB600	1/2" NPS, 1 pt., 50 micron
AB600F	1/2" NPS, 1 pt., 10 micron
AB601B	3/4" NPS, 1 pt., 10 micron
AB601C	3/4" NPS, 1 pt., 50 micron
AA800C	1/2" NPS, 1 qt., 10 micron
AA800E	1/2" NPS, 1 qt., 50 micron
AA900D	3/4" NPS, 1 qt., 10 micron
AA900J	3/4" NPS, 1 qt., 50 micron
V400G	1/2" NPS, 8 oz., 50 micron
V500D	3/4" NPS, 8 oz., 50 micron
V400C	1/2" NPS, 8 oz., 50 micron

FILTERS—metal jar

AB609D	1/2" NPS, 1/2 pt., 10 micron
AB612	1/2" NPS, 1/2 pt., 10 micron
AB608B	3/4" NPS, 1/2 pt., 10 micron
AS609	1/2" NPS, 1/2 pt., 50 micron
AB608	3/4" NPS, 1/2 pt., 50 micron
AB650C	3/4" NPS, 1 qt., 10 micron
AB650G	3/4" NPS, 1 qt., 50 micron
AB605	1/2" NPS, 1 qt., 50 micron
AB658B	1/2" NPS, 1 qt., 10 micron

FILTERS—plastic jar

AA922N	1/2" NPS, 3/4" oz.
V400M	1/2" NPS, 8 oz.
V500N	3/4" NPS, 8 oz.

FLUSHING SOLVENT

AH255	1 oz.
-------	-------

FOOT SUPPORT ASSEMBLIES

AC136	0211, 0322, 0522
AE240	1/2" 1/4" hp piston pumps
AE241	1/2" 3/4" hp piston pumps
AE245	1/2" hp piston pumps

GAUGES—pressure

AF547	1/2" NPS, 0-30 psi
AA514B	1/2" NPS, 0-30 psi 0-200 cm ²
AA806	1/2" NPS, 0-160 psi (back mount)
AA807	1/2" NPS, 0-160 psi (back mount)
AF563	1/2" NPS, 0-100 psi, heavy duty (bottom mount)

GAUGES—vacuum

AA640	1/2" NPS, 0-30" Hg, 0-760 mm Hg
AA641	1/2" NPS, 0-30" Hg

HANDLES—carrying

AF333	for 1/2" and 3/4" hp units
-------	----------------------------

MUFFLERS—glass jar

AB599B	3/4" NPS, 1 pt., 10 micron, for oil-less pumps
AB600C	1/2" NPS, 1 pt., 50 micron, for oil-less pumps
AB600J	1/2" NPS, 1 pt., 30 micron, for oil-less pumps
AD560	1" NPS, 2 qt., 50 micron
AB560B	1" NPS, 2 qt., 50 micron, with fitting for quieter operation
AA900F	3/4" NPS, 1 qt., 10 micron, for oil-less pumps
AA900G	3/4" NPS, 1 qt., 50 micron, for oil-less pumps
AA922B	1/2" NPS, 3/4" oz., 50 micron, for oil-less pumps
AA922G	same as AA922 but with silencing tube
AA617F	1/2" NPS, 2 oz., 50 micron, for oil-less pumps

MUFFLERS—metal jar

AB612A	1/2" NPS, 1/2 pt., 10 micron
AB609B	1/2" NPS, 1/2 pt., 10 micron
AB602A	3/4" NPS, 1/2 pt., 10 micron
AB603C	1/2" NPS, 1 qt., 10 micron
AB650D	3/4" NPS, 1 qt., 10 micron

MUFFLERS—plastic jar

AA922P	1/2" NPS, 3/4" oz.
V425M	1/2" NPS, 8 oz.
V525G	3/4" NPS, 8 oz.

OVERLOADS—motor

	External thermal protector, specify motor number and make
--	---

PAINT

AE564A	Gun blue-gray, 16 oz. aerosol can
--------	-----------------------------------

RELIEF VALVES—pressure

AA203	1/2" NPS, flow below 2 cfm
AA205	1/2" NPS, flow below 2 cfm
AA600	3/4" NPS, flow below 10 cfm
AA307	3/4" NPS, flow above 10 cfm
AF510S	1/2" NPS, 0-100 psi
AF720	1/2" NPT, 0-100 psi
AE900	1" NPT, 0-100 psi

RELIEF VALVES—vacuum

AA204	1/2" NPS, flow below 2 cfm
AA207	1/2" NPS, flow below 2 cfm
AA640A	3/4" NPS, flow from 2-10 cfm
AA308	3/4" NPS, flow above 10 cfm
AE961	1" NPS, for 4565, 5565

SWITCH—vacuum

AE265	1/2" NPS
-------	----------

TRAPS—vacuum

AA670	1/2" NPS, 8 oz.
AA673B	1/2" NPS, 2 oz.
AA675C	1/2" NPS, 2 oz.

TRUBLE SHOOTING GUIDE FOR ROTARY VANE PUMPS

REASONS FOR PROBLEM	Low		High		Pump Overheating	Motor Overload
	Vac.	Press.	Vac.	Press.		
Filter dirty	X	X	at pump		X	X
Muffler dirty		X		at pump	X	X
Vac. line collapsed	X		at pump		X	X
Relief valve set too high			X	X	X	X
Relief valve set too low	X	X				
Plugged vacuum or pressure line	X	X	at pump	at pump	X	X
Vanes sticking	X	X				
Running at too high RPM			X	X	X	X
Vanes worn (replace)	X	X				
Shaft seal worn (replace)	X	X				
Dust or offset powder in pump	X	X			X	X
Motor not wired correctly	X	X			X	

Oilless 1067, 2067, 2567 Series

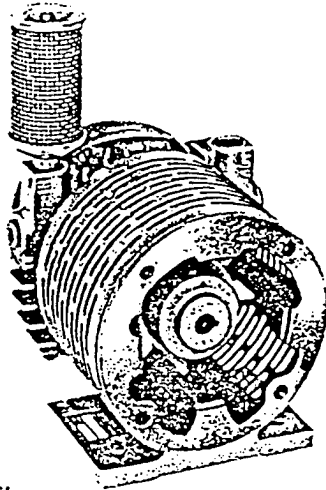

MODEL 1067 SERIES
15 PSI MAX. PRESSURE, 8.50 CFM OPEN FLOW

MODEL 2067 SERIES
15 PSI MAX. PRESSURE, 17.00 CFM OPEN FLOW

MODEL 2567 SERIES
15 PSI MAX. PRESSURE, 21.00 CFM OPEN FLOW

PRODUCT FEATURES

- Oilless operation
- Close coupled easy motor mounting
- Rugged construction/low maintenance
- Essentially pulse free service

INCLUDES

- Filter AA905F (1067), AA905G (2067-2567)
- Fan/coupling assembly AH198
- Fan guards AC102C, AH194

RECOMMENDED ACCESSORIES

- Pressure relief valve AA600 (1067), AA307 (2067/2567) U.S. version
- Pressure gauge AA644B (U.S. version)
- Repair kit K356 (1067)
- Repair kit K350 (2067/2567)

Important Notice:

Pictorial and dimensional data is subject to change without notice.

EUROPEAN MODEL

Product Dimensions Metric (mm)

Model	A	B	C	D	E	F	G	H	I	J	K	L	M	N
1067	195	100	144	72	288	180	102	11	125	165	241	142	19	80
2067	195	100	144	72	289	180	102	11	125	165	284	164	19	80
2567	195	100	144	72	289	180	102	11	125	165	284	164	19	80

U.S. MODEL

Product Dimensions Metric (mm) U.S. Imperial (inches)

Model	A	B	C	D	E	F	G	H	I	J	K	L	M	N
1067	195	145	287	180	132	102	11	124	165	241	142	495	21	76
1067	7.69	5.69	11.31	7.09	5.19	4.0	.44	4.88	6.50	9.50	5.59	19.50	.84	3.00
2067	194	145	287	180	132	102	11	124	165	284	164	584	21	76
2067	7.63	5.69	11.31	7.09	5.19	4.0	.44	4.88	6.50	11.19	6.44	23.00	.84	3.00
2567	194	145	287	180	132	102	11	124	165	284	164	584	21	76
2567	7.63	5.69	11.31	7.09	5.19	4.0	.44	4.88	6.50	11.19	6.44	23.00	.84	3.00

Dimensions for reference only.

METRIC MODEL

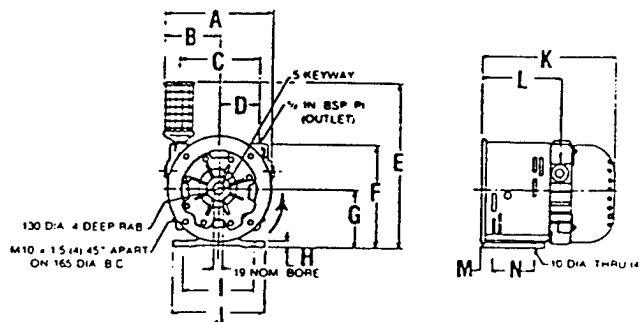

INLET
2067/2567 1/4 IN. BSP.
1067 1/2 IN. BSP.

U.S./IMPERIAL MODELS NEMA 56, C FACE

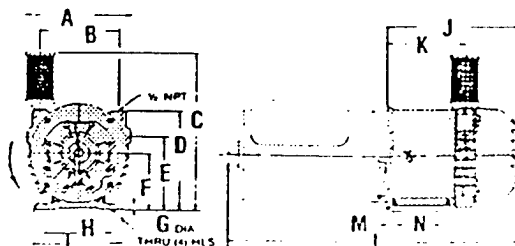

INLET
2067/2567 1/4 NPT
1067 1/2 NPT

Product Specifications

Model Number	Motor	RPM		HP	kW	Net Wt.	
		60 cycle	50 cycle			lbs.	kg
1067-P102	Not included	1725	1425	1	0,75	34	15,40
1067-P104 (metric)	Not included	1725	1425	1	0,75	34	15,40
†1067-P106-G561X (like 1067-P102 plus motor)	110/220-240; 115/208-230; 50/60-1	1725	—	1	0,75	65	29,5
2067-P102	Not included	1725	1425	1	0,75	47	21,3
2067-P104 (metric)	Not included	1725	1425	1	0,75	47	21,3
†2067-P106-G561X (like 2067-P102 plus motor)	110/220-240; 115/208-230; 50/60-1	1725	—	1	0,75	92	41,7
2567-P102	Not included	1725	1425	2	1,5	46	20,9
2567-P104 (metric)	Not included	1725	1425	2	1,5	46	20,9
2567-P106-G475 (like 2567-P102 plus motor)	230/460-60-3	1725	—	2	1,5	81	36,8

†Motor includes Thermotector.

Product Performance (Metric U.S. Imperial) Black line on curve is for 60 cycle performance.
Blue line on curve is for 50 cycle performance.

Model 1067

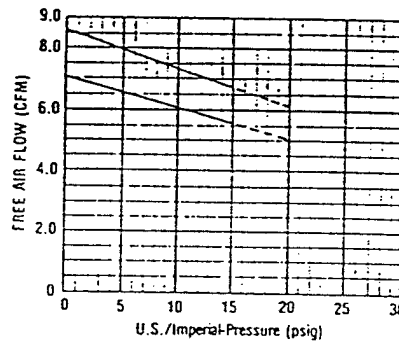
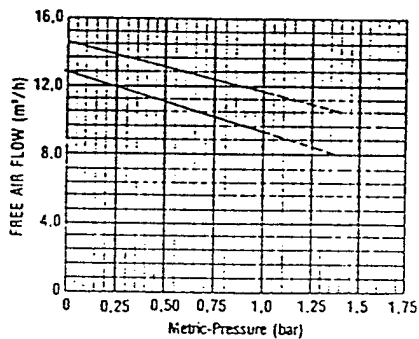

Model 2067

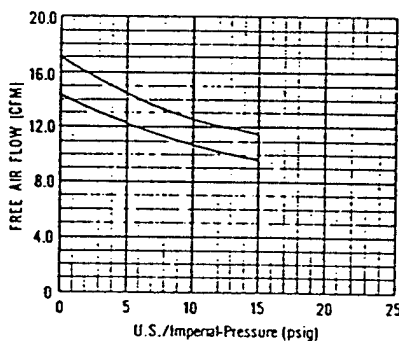
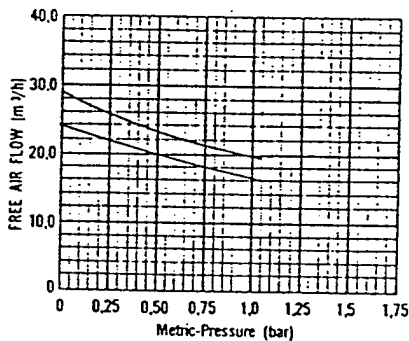

Model 2567

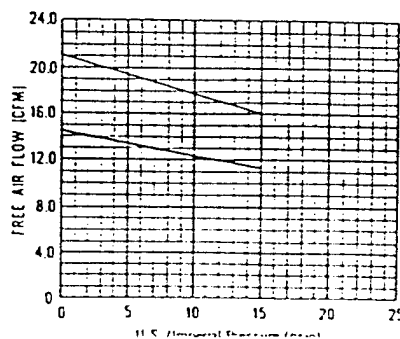
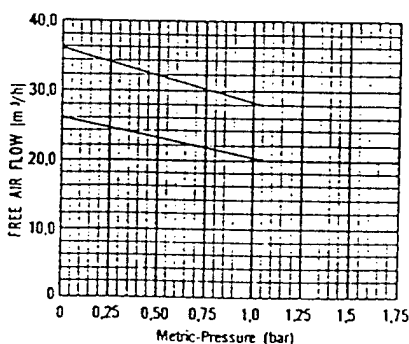

APPENDIX B
DATA COLLECTION SHEET

