

LOAN DOCUMENT

PHOTOGRAPH THIS SHEET

DTIC ACCESSION NUMBER



LEVEL

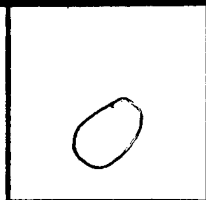

INVENTORY

BIOVENTING TEST WORK PLAN...

DOCUMENT IDENTIFICATION

NOV 94

DISTRIBUTION STATEMENT A
Approved for Public Release
Distribution Unlimited

DISTRIBUTION STATEMENT

ACCESSION FOR	
NTIS	GRAM <input checked="" type="checkbox"/>
DTIC	TRAC <input type="checkbox"/>
UNANNOUNCED	<input type="checkbox"/>
JUSTIFICATION	<input type="checkbox"/>
BY	
DISTRIBUTION/	
AVAILABILITY CODES	
DISTRIBUTION	AVAILABILITY AND/OR SPECIAL
<i>A-1</i>	

DISTRIBUTION STAMP

DATE ACCESSIONED

DATE RETURNED

DTIC QUALITY INSPECTED &
20001226 026

DATE RECEIVED IN DTIC

REGISTERED OR CERTIFIED NUMBER

PHOTOGRAPH THIS SHEET AND RETURN TO DTIC-FDAC

H
A
N
D
L
E

W
I
T
H

C
A
R
E

DRAFT

**BIOVENTING TEST WORK PLAN AND
INTERIM BIOVENTING PILOT TEST
RESULTS REPORT FOR
BULK FUEL STORAGE AREA 1595
FORT DRUM, NEW YORK**

Prepared For:

**Air Force Center for Environmental Excellence
Brooks AFB, Texas**

and

**10th Mountain Division
Directorate of Engineering and Housing
Engineering Division
Fort Drum, New York**

**Prepared By:
ENGINEERING-SCIENCE, INC.**

November 1994

**290 Elwood Davis Road
Liverpool, New York 13088**

ES ENGINEERING-SCIENCE

ARMO1-03-0572

DEFENSE TECHNICAL INFORMATION CENTER REQUEST FOR SCIENTIFIC AND TECHNICAL REPORTS

Title AFCEE Collection

1. Report Availability (Please check one box)
 This report is available. Complete sections 2a - 2f.
 This report is not available. Complete section 3.

2a. Number of Copies Forwarded
1 each

2b. Forwarding Date
July/2000

2c. Distribution Statement (Please check ONE box)
DoD Directive 5230.24, "Distribution Statements on Technical Documents," 18 Mar 87, contains seven distribution statements, as described briefly below. Technical documents MUST be assigned a distribution statement.
 DISTRIBUTION STATEMENT A: Approved for public release. Distribution is unlimited.
 DISTRIBUTION STATEMENT B: Distribution authorized to U.S. Government Agencies only.
 DISTRIBUTION STATEMENT C: Distribution authorized to U.S. Government Agencies and their contractors.
 DISTRIBUTION STATEMENT D: Distribution authorized to U.S. Department of Defense (DoD) and U.S. DoD contractors only.
 DISTRIBUTION STATEMENT E: Distribution authorized to U.S. Department of Defense (DoD) components only.
 DISTRIBUTION STATEMENT F: Further dissemination only as directed by the controlling DoD office indicated below or by higher authority.
 DISTRIBUTION STATEMENT X: Distribution authorized to U.S. Government agencies and private individuals or enterprises eligible to obtain export-controlled technical data in accordance with DoD Directive 5230.26, Withholding of Unclassified Technical Data from Public Disclosure, 6 Nov 84.

2d. Reason For the Above Distribution Statement (in accordance with DoD Directive 5230.24)

2e. Controlling Office
HQ AFCEE

2f. Date of Distribution Statement Determination
15 Nov 2000

3. This report is NOT forwarded for the following reasons. (Please check appropriate box)
 It was previously forwarded to DTIC on _____ (date) and the AD number is _____
 It will be published at a later date. Enter approximate date if known. _____
 In accordance with the provisions of DoD Directive 3200.12, the requested document is not supplied because:

Print or Type Name
Laura Peña
Telephone
210-536-1431

Signature
Laura Peña
(For DTIC Use Only)
AQ Number M01-03-0572

DRAFT

**BIOVENTING TEST WORK PLAN AND
INTERIM BIOVENTING PILOT TEST
RESULTS REPORT FOR
BULK FUEL STORAGE AREA 1595
FORT DRUM, NEW YORK**

Prepared For:

**Air Force Center for Environmental Excellence
Brooks AFB, Texas**

and

**10th Mountain Division
Directorate of Engineering and Housing
Engineering Division
Fort Drum, New York**

**Prepared By:
ENGINEERING-SCIENCE, INC.**

November 1994

**290 Elwood Davis Road
Liverpool, New York 13088**

PART I
DRAFT BIOVENTING TEST WORK PLAN FOR
AREA 1595 FUEL STORAGE AREA
FORT DRUM, NEW YORK

Prepared for

Air Force Center for Environmental Excellence
Brooks AFB, Texas

and

Directorate of Engineering and Housing
Environmental Division
Fort Drum, New York

by

Engineering-Science, Inc
290 Elwood Davis Road
Liverpool, New York

August 1994

TABLE OF CONTENTS

1.0 INTRODUCTION	1
2.0 SITE DESCRIPTION	1
2.1 Site Location and History.....	1
2.2 Site Geology.....	2
2.3 Site Contaminants.....	2
3.0 PILOT TEST ACTIVITIES	2
3.1 Introduction.....	2
3.2 Well Siting and Construction.....	4
3.3 Handling of Drill Cuttings.....	8
3.4 Soil and Soil Gas Sampling.....	8
3.4.1 Soil Sampling.....	8
3.4.2 Soil Gas Sampling	8
3.5 Blower System	10
3.6 Air Monitoring	10
3.7 In situ Respiration Test	10
3.8 Air Permeability Test	11
3.9 Design and Installation of Extended Pilot Test Bioventing System.....	11
4.0 EXCEPTIONS TO PROTOCOL PROCEDURES	11
5.0 BASE SUPPORT REQUIREMENTS.....	11
6.0 PROJECT SCHEDULE.....	12
7.0 POINTS OF CONTACT.....	13
8.0 REFERENCES	13

LIST OF FIGURES

Figure 2.1 Site Location Map	3
Figure 3.1 Proposed Vent Well/Vapor Monitoring Point Locations at Area 1595	5
Figure 3.2 Central Injection Vent Well Construction Detail	6
Figure 3.3 Monitoring Point Construction Detail	7
Figure 3.4 Schematic of Initial Test Phase Blower System	9

PART I

DRAFT BIOVENTING TEST WORK PLAN FOR

AREA 1595 FUEL STORAGE AREA

FORT DRUM, NEW YORK

1.0 INTRODUCTION

This test work plan presents the scope of an *in situ* bioventing pilot test for treatment of fuel contaminated soils located at the Area 1595 Fuel Storage Area at Fort Drum, New York. The pilot test has three primary objectives: 1) to assess the potential for supplying oxygen throughout the contaminated soil depth, 2) to determine the rate at which indigenous microorganisms will degrade fuel when stimulated by oxygen rich soil gas, and 3) to evaluate the potential for sustaining these rates of biodegradation until fuel contamination is remediated below regulatory standards.

Pilot testing will consist of two phases, an initial air permeability test and *in situ* respiration test which will take place in June of 1994; and an extended one year pilot test which will be used to determine the potential for bioventing remediation using natural nutrient levels. Testing will also provide an estimate of cold weather biodegradation rates. The initial and extended pilot test will serve as treatability studies under the CERCLA feasibility study process. If bioventing proves to be feasible at this site, pilot test data may be used to design a full-scale remediation system and to estimate the time required for site cleanup.

The initial test will involve injection at a single vent well with a regenerative blower to produce a radius of influence of approximately 40 feet. *In situ* rates of fuel biodegradation and soil gas permeability will be determined during this short term test and a decision on how best to proceed with extended testing will be made with regulatory concurrence.

Additional background information on the development and recent success of the bioventing technology is found in the attached document entitled *Test Plan and Technical Protocol For A Field Treatability Test For Bioventing, Revision 2* (Hinchee, et al. May, 1992). This protocol document is a supplement to the site-specific work plan, and it will also serve as the primary reference for pilot test vent well and vapor monitoring point designs and detailed test objectives and procedures. Unless otherwise noted, test procedures outlined in the protocol document will be used during the pilot test at Area 1595.

2.0 SITE DESCRIPTION

2.1 Site Location and History

Fort Drum is an U.S. Army Post located in north-central New York near Watertown, NY. Fort Drum was established in 1906, encompasses 168 square miles and is currently home to the Army's 10TH Mountain Division. Located on Fort Drum is an area known as Gasoline Alley. This fuel dispensing area consists of nine separate

fueling stations stretching for approximately 1.7 miles along Oneida Avenue. Vehicle and equipment storage yards are located to the south of Gasoline Alley, and a rail line and heavily wooded area lies to the north. Each of the nine fueling stations is supplied by underground storage tanks (USTs) located adjacent to the dispensing areas. Diesel fuel, gasoline, and jet fuels have been stored and dispensed from Gasoline Alley.

The Area 1595 storage area (Figure 2.1) is a part of Gasoline Alley and is comprised of one 12,000 gallon UST and two 25,000 gallon USTs. These tanks are scheduled for removal in May 1994. Over the past 19 years, a number of site investigations have revealed extensive soil and groundwater contamination downgradient (to the north) of the storage area. A February 1990 report produced by O'Brien and Gere Engineers indicated that vadose zone soil contamination extends for approximately 350 feet downgradient of the storage tanks. The hydrocarbon contamination located to the north of the railroad tracks is the target for bioventing treatment at this site.

2.2 Site Geology

Because the bioventing technology is applied to the unsaturated soils, this section will primarily address soils above the shallow aquifer. Soils above the water table at this site consist of fine grained sands which extend to a depth of 80 to 100 feet. A clay layer is encountered below the sand layer and above the limestone bedrock. Groundwater is encountered at a depths ranging from 4.5 to 17 feet below ground surface (bgs). Groundwater near the proposed pilot test area is encountered at approximately 10 to 14 feet bgs.

Due to the homogeneous nature of the sand, the permeability of soils to air flow should remain relatively constant across the site. Effective bioventing on this site is likely. Engineering-Science has completed successful bioventing projects within similar geological deposits and we are confident that oxygen can be distributed in these soils.

2.3 Site Contaminants

The primary contaminants in the Area 1595 soils appear to be diesel fuel and possibly some gasoline residuals which have migrated downward to the water table. Soil samples collected inside the source area and above the water table showed TPH concentrations from non-detect to 17,000 mg/kg. The volatile organic compounds benzene, toluene, ethylbenzene, and total xylenes (BTEX) were detected in the soils above the water table from non-detectable to 262 mg/kg.

3.0 PILOT TEST ACTIVITIES

3.1 Introduction

The purpose of this section is to describe the work that will be performed by Engineering-Science, Inc. (ES) at Area 1595. Activities associated with the initial test phase include siting and construction of a central vent well (VW) and three vapor monitoring points (VMPs); an *in situ* respiration test; and an air permeability test. Soil and soil gas sampling procedures and the blower configuration that will be used to

FIGURE 2.1

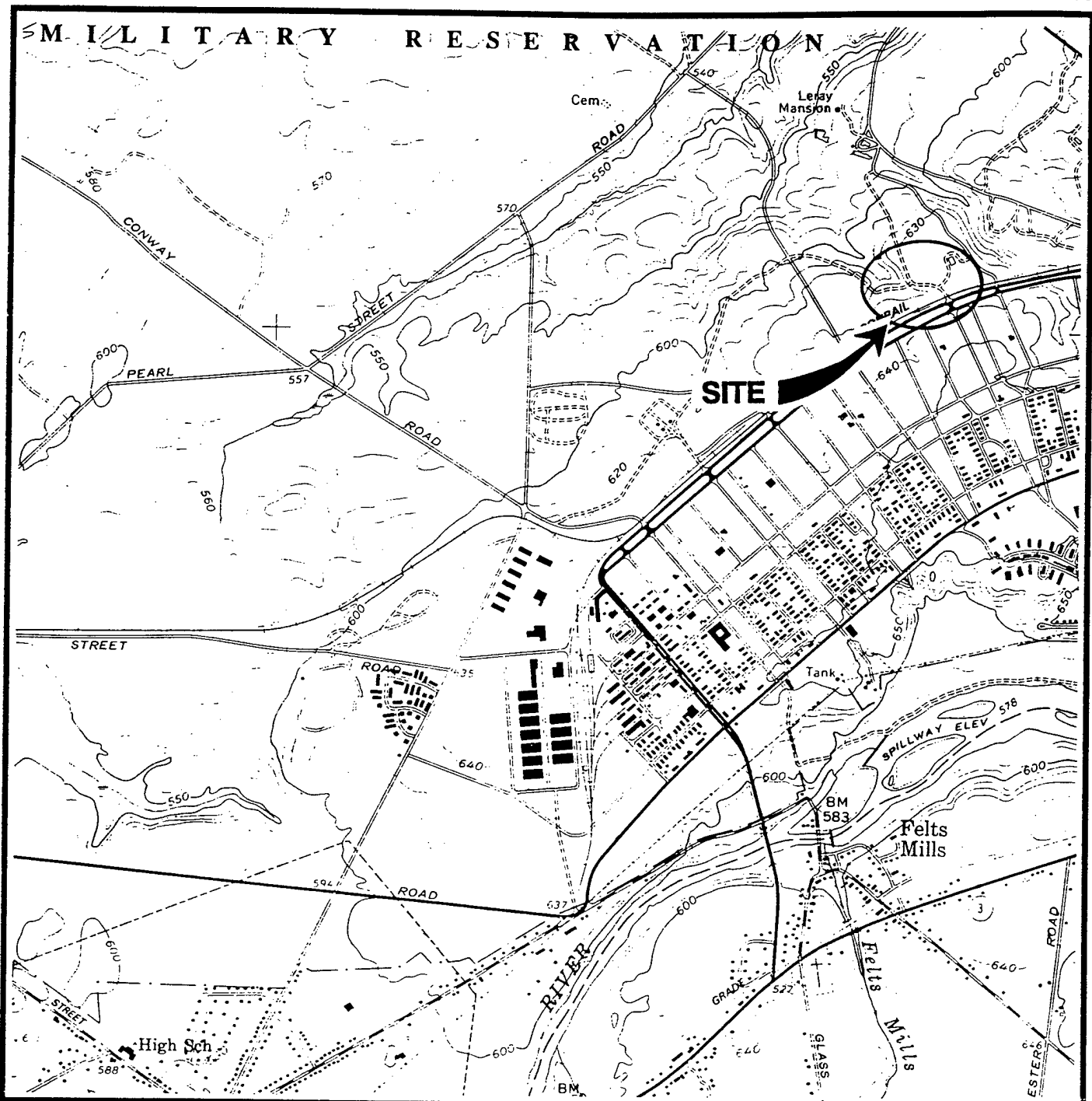

SOURCE: U.S.G.S. 7.5 MINUTE TOPOGRAPHIC MAP; BLACK RIVER, NEW YORK, 1958 (PHOTOREVISED 1982)

SCALE
0 2000 4000 FT.



ES ENGINEERING-SCIENCE

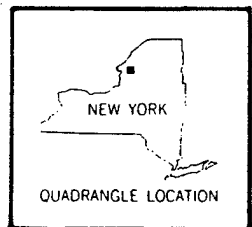

LONGITUDE: 75° 45' 30"
LATITUDE: 44° 02' 30"

**SITE LOCATION MAP
FORT DRUM, NEW YORK**

inject air (oxygen) into contaminated soils are also discussed in this section. In an effort to be as cost effective as possible, a single VW will be completed to the depth of lowest seasonal groundwater at the site. Pilot test activities will be confined to unsaturated soils remediation; no dewatering will take place during the pilot tests. Existing monitoring wells will not be used as primary air injection or extraction wells. However, monitoring wells which have a portion of their screened interval above the water table may be used as VMPs or to measure the composition of background soil gas.

3.2 Well Siting and Construction

A general description of criteria for siting the single central VW and associated VMPs are included in the protocol document. Figure 3.1 illustrates the proposed location of the central VW and VMPs at Area 1595. The final location of the VW may vary slightly from the proposed location if significant fuel contamination is not observed in the boring for the central VW. Based on site investigation data and discussions with base personnel, the VW will be located near the existing groundwater monitoring well OBG-2, and approximately 50 feet north of the railroad tracks. The area is expected to have an average TPH concentration exceeding 1,000 mg/kg. Soils in this area are expected to be oxygen depleted (< 2%) and increased biological activity should be stimulated by oxygen-rich soil gas ventilation during full-scale operations.

Due to the relatively shallow depth of contamination at this site and the potential for high permeability soils, the radius of venting influence around the central air injection well is expected to reach approximately 40 feet. Three VMPs will be located within a 40-foot radius of the central VW. Background monitoring for the site will occur at either an existing uncontaminated well near Area 1595, or at a background monitoring point which will be installed at an upgradient location south of the site during the VW and VMP installations.



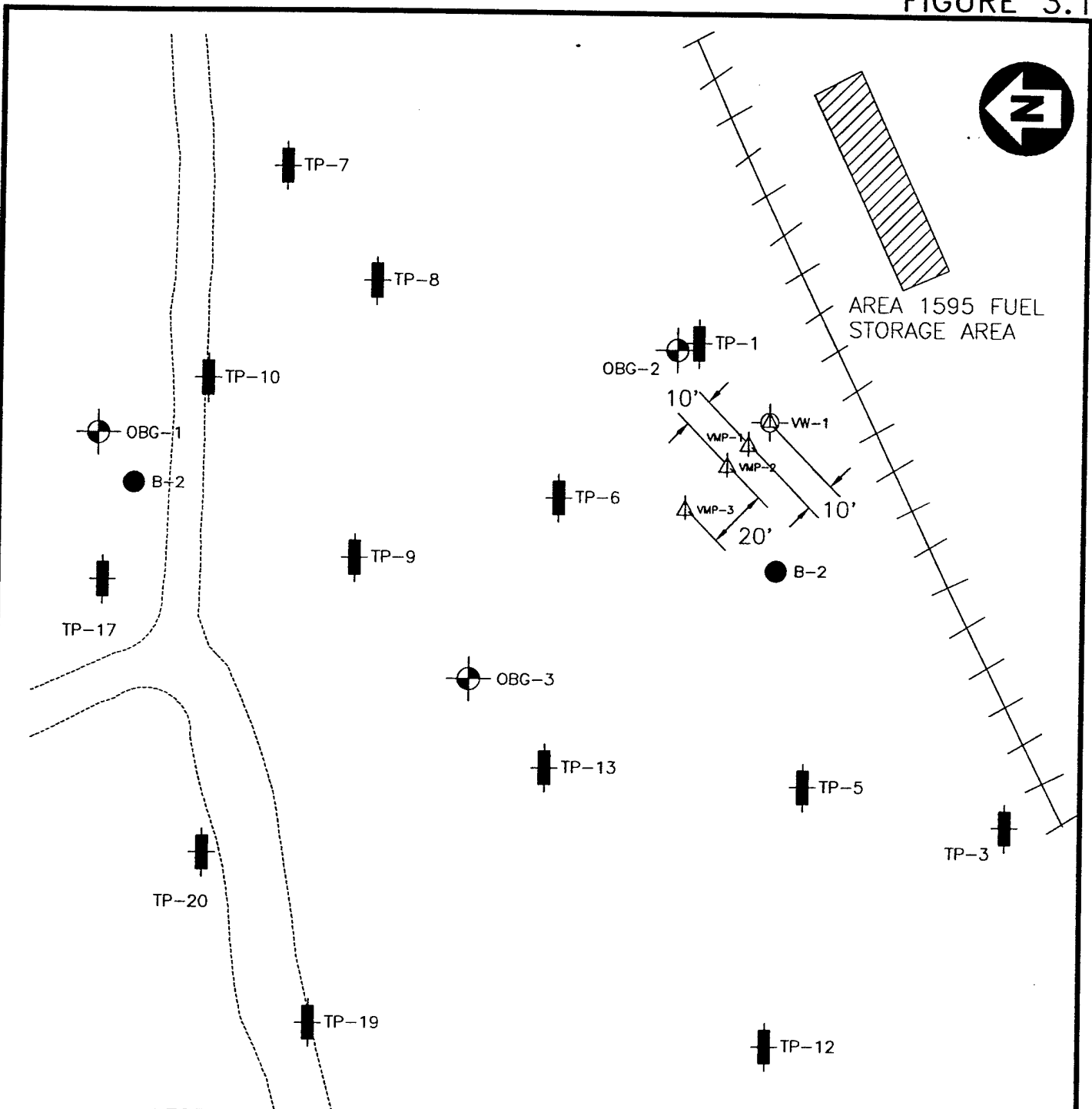

The VW will be constructed of 4-inch diameter Schedule 40 PVC, with a 10 foot interval of 0.04 slotted screen set between 5 and 15 feet bgs. Flush-threaded PVC casing and screen will be used with no organic solvents or glues. The filter pack will be clean, well-rounded silica sand with a 6-9 grain size and will be placed in the annular space of the screened interval. A 2-foot layer of bentonite will be placed directly over the filter pack. The bentonite will consist of granular bentonite and/or pellets placed in 6-inch lifts and hydrated in place with potable water to produce an air tight seal above the screened interval. A complete seal is critical to prevent injected air from short-circuiting to the surface during the bioventing test. Silica sand and cement grout will be placed over the pellets and extend to the ground surface. An above grade locking well cover will be installed to complete the VW installation. Figure 3.2 illustrates the proposed central VW construction details for this site.

A typical multi-depth VMP installation for this site is shown in Figure 3.3. Soil gas oxygen and carbon dioxide concentrations will be monitored at depth intervals of approximately 3 to 5 feet bgs, 6.5 to 8.5 feet bgs, and 10 to 12 feet bgs at each location. Multi-depth monitoring will confirm that the entire soil profile is receiving oxygen and will be used to measure fuel biodegradation rates at all depths. The

FIGURE 3.1



LEGEND

-  OBG-8 EXISTING GROUNDWATER MONITORING WELL
-  TP-16 TEST PIT LOCATION
-  B-2 SOIL BORING LOCATION
-  VW-1 PROPOSED VENT WELL LOCATION
-  VMP-1 PROPOSED VAPOR MONITORING POINT LOCATION



PROPOSED PILOT STUDY
TEST AREA
FORT DRUM, NEW YORK

ENGINEERING-SCIENCE
DESIGN • RESEARCH • PLANNING
SYRACUSE, NEW YORK



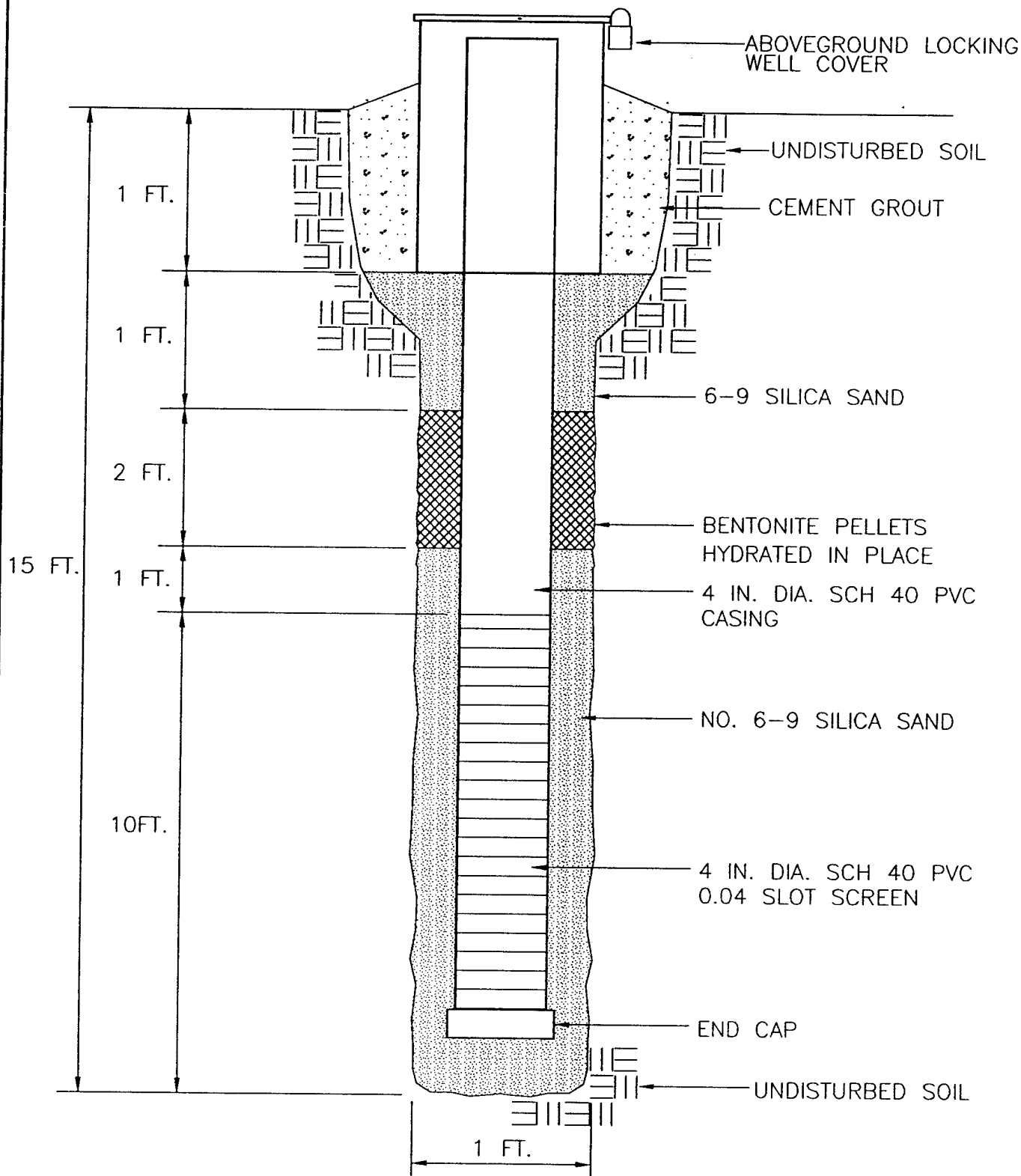

NOT TO SCALE

INJECTION VENT WELL
CONSTRUCTION DETAIL

FORT DRUM, NEW YORK

ENGINEERING-SCIENCE, INC.
Syracuse, New York



FIGURE 3.3

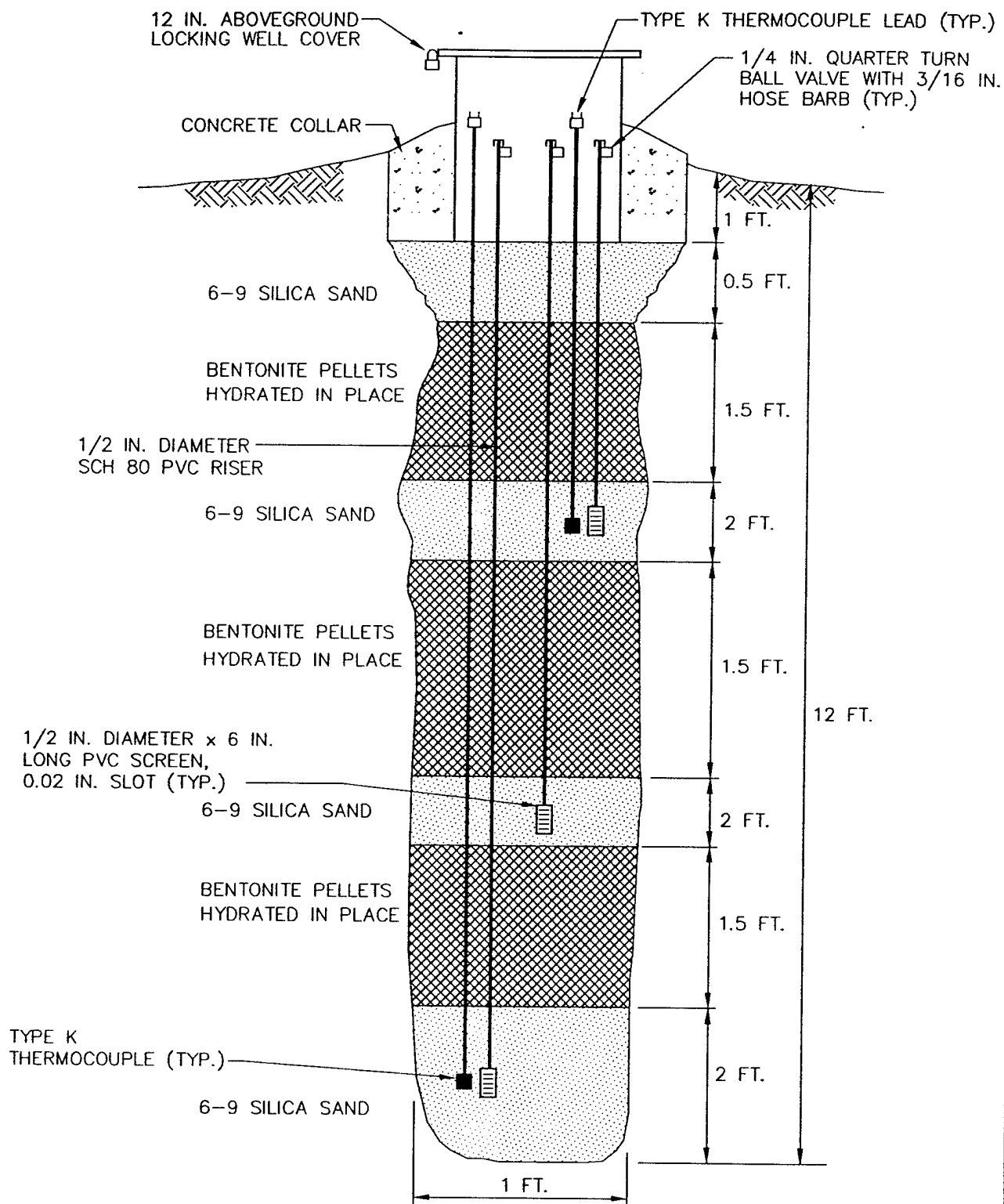

NOT TO SCALE

TYPICAL MONITORING POINT
CONSTRUCTION DETAIL

FORT DRUM, NEW YORK

ENGINEERING-SCIENCE, INC.
Syracuse, New York



annular space between the three monitoring points will be sealed with bentonite to isolate the monitoring intervals. Additional details on VW and monitoring point construction are found in Section 4 of the protocol document.

3.3 Handling of Drill Cuttings

Drill cuttings from all borings will be screened in the field with a total hydrocarbon vapor analyzer (protocol document, Section 4.5.2). Cuttings above background levels (typically less than 1 part per million) will be temporarily drummed and transported to the current soil stockpile area at the base. At the stockpile area, the soils will be removed from the drums, and the drums reused at the next boring location. Cuttings below background will be spread on the ground near the soil borings.

3.4 Soil and Soil Gas Sampling

3.4.1 Soil Sampling

Four soil samples will be collected from the pilot test area during the installation of the VW and VMPs. One sample will be collected from the most contaminated interval of the central VW boring, and one sample will be collected from the interval of highest apparent contamination in each of the borings for two VMPs at the site. These three soil samples will be analyzed for TPH, BTEX, soil moisture, pH, particle sizing, alkalinity, total iron, total Kjeldahl nitrogen (TKN), and total phosphate. The fourth soil sample will be collected from uncontaminated soil to the east of the pilot test area, and be analyzed for TKN only.

Soil samples will be collected using a split-spoon sampler containing brass tube liners. A photoionization detector or total hydrocarbon vapor analyzer will be used to insure that breathing zone levels of volatiles do not exceed 1 ppm during drilling, and to screen split spoon samples to verify intervals of high fuel contamination. Soil samples collected in the brass tubes will be immediately trimmed and aluminum foil and a plastic cap placed over the ends. Soil samples will be labelled following the nomenclature specified in the protocol document (Section 5.5), wrapped in plastic, and placed in an ice chest for shipment. A chain of custody form will be filled out and the ice chest shipped to the Pace laboratory in Huntington Beach, California, for analysis.

3.4.2 Soil Gas Sampling

A total of three soil gas samples will be collected in SUMMA[®] canisters in accordance with the *Bioventing Field Sampling Plan* (ES, 1992). The samples will be collected from the VW and from the VMPs closest to and furthest from the VW at the site. These soil gas samples will be used to predict potential air emissions, to determine the reduction in BTEX and total volatile hydrocarbons (TVH) during the 1-year test, and to detect any migration of these vapors from the source area.

Soil gas sample canisters will be placed in a small cooler and packed with foam pellets to prevent excessive movement during shipment. Samples will not be sent on ice to prevent condensation of hydrocarbons. A chain-of-custody form will be filled out, and the cooler will be shipped to the Air Toxics laboratory in Folsom, California for analysis.

3.5 Blower System

A 1.0-HP regenerative blower capable of injecting 30 - 90 scfm will be used to conduct the initial air permeability test at the site. This blower provides a wide range of flow rates and should develop sufficient pressure to move air through high permeability soils. A schematic of the initial test phase blower system is presented as Figure 3.4. Air injection will be used to provide oxygen to soil bacteria and to minimize emissions of volatiles to the atmosphere.

An extended pilot test will be performed if initial pilot testing is positive (i.e. ability to transport oxygen throughout the contaminated soil and a positive oxygen utilization rate). The extended bioventing test will be initiated following a review of initial test data and regulatory approval.

The maximum power requirement anticipated for the extended test system is 230-volt, 30-amp, single phase service. Additional details on power supply requirements are described in Section 5.0, Base Support Requirements.

3.6 Air Monitoring

The bioventing technique will minimize total emissions of more volatile hydrocarbons to the atmosphere. This is accomplished by reducing air injection rates to supply only the minimum required oxygen to sustain the indigenous microorganisms. By supplying only the required oxygen for biodegradation, volatilization is minimized.

During all activities involving air injection, the air at the ground surface and at the breathing zone within a 20-foot radius of the injection well will be monitored for volatile hydrocarbons by use of a total volatile hydrocarbon analyzer. Air monitoring will be done to ensure safe working conditions and to provide a rough estimate of volatilization losses, if they occur. More intense air monitoring is required during the first eight hours of the air permeability test because the potential for emission of the more volatile hydrocarbons is greatest at that time.

The potential for emissions at this site is minimal because of the age and type of the fuel residuals. The contamination is estimated to be at least 10 years old and to consist mainly of diesel fuel, which contains a minimal amount of volatile components. Additionally, the site is in a heavily vegetated area, which tends to act as a biofilter to control hydrocarbon emissions.

3.7 In situ Respiration Test

The objective of the *in situ* respiration test is to determine the rate at which soil bacteria degrade petroleum hydrocarbons. Respiration tests will be performed at the four VMPs with the highest apparent fuel contamination at the site. Atmospheric air will be injected into each VMP depth interval containing low levels (<2%) of oxygen. A 20 to 24-hour air injection period will be used to oxygenate local contaminated soil around the VMPs. At the end of the air injection period, the air supply will be cut off, and oxygen and carbon dioxide levels will be monitored for five days or until the oxygen level falls below 5 %, whichever is earlier. The decline in oxygen and increase in carbon dioxide concentrations over time will be used to estimate rates of bacterial degradation of fuel residuals.

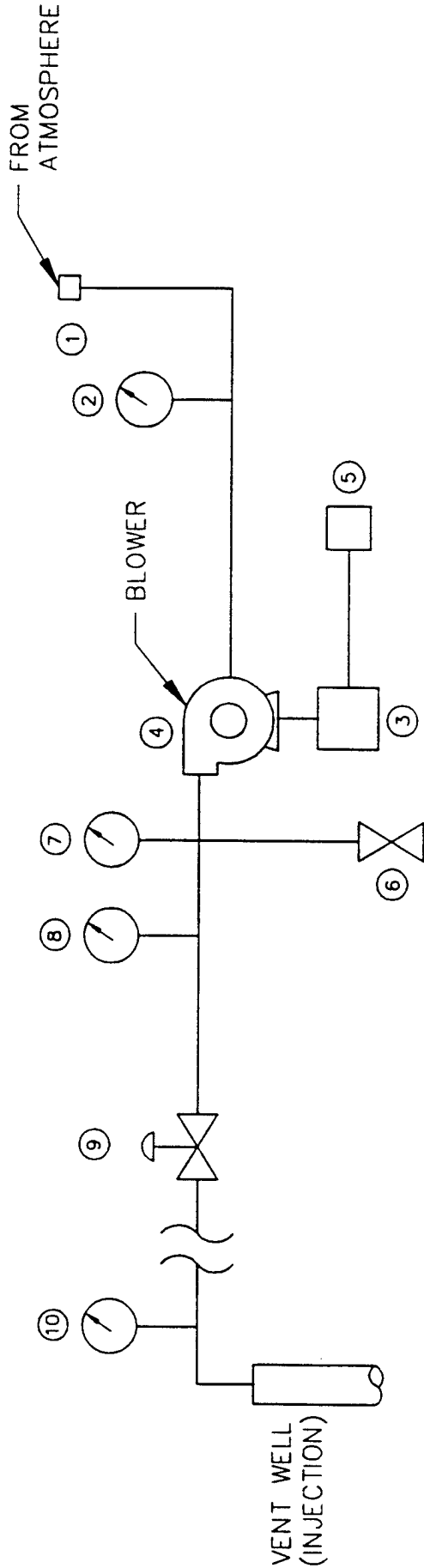

- ① INLET FILTER
- ② VACUUM GAUGE - INCHES OF H2O
- ③ DRIVE MOTOR
1.0 HP / 3450 RPM @ 60 Hz / 230 v / SINGLE PHASE / 11 A
- ④ BLOWER - GAST 4110-2 / REGENERATIVE
70 SCFM @ 20 INCHES H₂O
- ⑤ STARTER
230 v / 15 A / SINGLE PHASE
- ⑥ AUTOMATIC PRESSURE RELIEF VALVE - SET @ 45 INCHES H2O
- ⑦ PRESSURE GAUGE (INCHES OF H2O)
- ⑧ THERMOMETER (FAHRENHEIT)
- ⑨ MANUAL PRESSURE RELIEF (BLEED) VALVE - 1 1/2" BALL
- ⑩ AIR VELOCITY MEASUREMENT PORT

SCHEMATIC OF BLOWER
SYSTEM FOR AIR INJECTION

FORT DRUM, NEW YORK

ES
ENGINEERING-SCIENCE, INC.
Syracuse, New York

Concurrent to the air injection period, a helium tracer will also be injected at the VMPs at a concentration of two to five percent. Helium levels will be monitored along with the oxygen and carbon dioxide levels to ensure that the VMPs do not leak. Additional details on the *in situ* respiration test are found in Section 5.7 of the protocol document.

3.8 Air Permeability Test

The objective of the air permeability test is to determine the extent of the subsurface that can be oxygenated using an air injection VW. Air will be injected into the 4-inch-diameter VW using the blower unit, and pressure response will be measured at each VMP with differential pressure gauges to determine the region influenced by the unit. Oxygen will also be monitored in the VMPs to verify that oxygen levels in the soil increase as the result of air injection. One air permeability test lasting approximately 4 to 8 hours will be performed.

3.9 Design and Installation of Extended Pilot Test Bioventing System

An extended, 1-year bioventing pilot system will also be designed and installed at Area 1595 following the initial test phase. The base will be requested to provide a power pole with a 230-volt, single-phase, 30-amp breaker box. Two 115-volt receptacles will also be required. Depending on the availability of a base electrician, either the base electrician or a licensed electrician subcontracted to ES will assist in wiring the blower to line power. The blower will be housed in a prefabricated shelter to provide protection from the weather.

The extended pilot system will be in operation for 24-hours per day for 1 year. Following start-up of the extended blower system, ES personnel will conduct *in situ* respiration tests at 6 and 12 months to monitor the long-term performance of this bioventing system. Weekly system checks will be performed by Fort Drum personnel. If required, major maintenance of the blower unit may be performed by ES personnel. Detailed blower system information and a maintenance schedule will be included in the operation and maintenance (O&M) manual which will be provided to the base as an attachment to the initial test results report. More detailed information regarding the test procedures can be found in the protocol document.

4.0 EXCEPTIONS TO PROTOCOL PROCEDURES

The procedures that will be used to measure the air permeability of the soil and *in situ* respiration rates are described in Sections 4 and 5 of the protocol document. No exceptions to this protocol are anticipated.

5.0 BASE SUPPORT REQUIREMENTS

The following base support is needed prior to the arrival of a driller and the ES test team:

- Assistance in obtaining regulatory approval for the pilot test if required.
- Assistance in obtaining a digging permit at the site.

- Provision of any paperwork required to obtain gate passes and security badges for approximately two ES employees and two drillers. Vehicle passes will be needed for two trucks and a drill rig.

During the initial two week pilot test the following base support is needed:

- Twelve square feet of desk space and a telephone in a building located as near to the site as practical.
- The use of a fax machine for transmitting 15 to 20 pages of test results.

Note: If required, a generator can be supplied by ES to provide power to the blower during the initial pilot test.

Prior to and during the one year extended pilot test the following base support is needed:

- A breaker box within 50 feet of the proposed blower enclosure which can supply 230-volt, single-phase, 30-amp service for the extended pilot test. If the base can not provide electrical support, please contact Mr. David Brown of ES-Syracuse at (315) 451-9560.
- Check the blower system at least once a week to ensure that it is operating and to record the air injection and vacuum pressures. ES will provide a brief training session on this procedure.
- Notify Mr. David Brown, ES-Syracuse, (315) 451-9560; or Mr. Marty Faille of AFCEE, (210) 536-4331, if the blower or motor stop working.
- Arrange site access for an ES technician to conduct *in situ* respiration tests approximately six months and one year after the initial pilot test.

6.0 PROJECT SCHEDULE

The following schedule is contingent upon timely approval of this pilot test work plan.

Event	Date
Draft Test Work Plan to AFCEE	26 May 1994
Base/Regulatory Approval To Proceed	13 June 1994
Begin Initial Phase Test	27 June 1994
Complete Initial Phase Test	15 July 1994
Interim Results Report	25 August 1994
Six-Month Respiration Test	December 1994
Final Respiration Test/Soil Sampling	June 1995

7.0 POINTS OF CONTACT

DON BEAVERS

Ms. Shelly Spayde
Directorate of Engineering and Housing
Environmental Division
Fort Drum, New York 13602-5097
(315) 772-4211

Mr. Marty Faille
AFCEE/EST
Brooks AFB, Texas 78235-5000
(210) 536-4342

Mr. David Brown
Engineering-Science, Inc
290 Elwood Davis Road, Suite 312
Liverpool, New York 13088
(315) 451-9560 Fax.(315) 451-9570

8.0 REFERENCES

- O'Brien & Gere Engineers, Inc. 1990. *Remedial Investigation Fuel Dispensing Area 1595 Fort Drum, New York*. Syracuse, New York. February.
- Engineering-Science, Inc. 1992. *Project Management Plan for AFCEE Bioventing, Appendix D, Field Sampling Plan*. Denver, Colorado. April.
- Hinchee, R.E., S.K. Ong, R.N. Miller, D.C. Downey, R. Frandt. 1992. *Test Plan and Technical Protocol for a Field Treatability Test for Bioventing, Revision 2*. Columbus, Ohio. May.

PART II
DRAFT INTERIM BIOVENTING PILOT TEST RESULTS REPORT
FOR
BULK STORAGE AREA 1595
FORT DRUM, NEW YORK

Prepared For:

Air Force Center for Environmental Excellence
Brooks AFB, Texas

and

10th Mountain Division
Directorate of Engineering and Housing
Engineering Division
Fort Drum, New York

by:

Parsons Engineering Science, Inc.
290 Elwood Davis Road
Liverpool, New York

November 1994

TABLE OF CONTENTS

1.0 Pilot Test Design and Construction	II-1
1.1 Vent Well Construction.....	II-1
1.2 Soil Vapor Monitoring Points	II-1
1.3 Blower Unit Installation	II-5
2.0 Pilot Test Soil And Soil Gas Sampling Results.....	II-5
2.1 Soil and Soil Gas Sampling Results.....	II-5
2.2 Exceptions to Test Protocol Document Procedures.....	II-8
2.3 Field QA/QC Results	II-8
3.0 Pilot Test Results	II-8
3.1 Initial Soil Gas Chemistry	II-8
3.2 Air Permeability	II-11
3.3 Oxygen Influence.....	II-11
3.4 <i>In Situ</i> Respiration Rates	II-11
3.5 Potential Air Emissions.....	II-14
4.0 Recommendations.....	II-14
5.0 References	II-19

LIST OF FIGURES

Figure 1.1 Bioventing Pilot Test Study Area II-2

Figure 1.2 Hydrogeologic Profile II-3

Figure 1.3 Air Injection Vent Well Construction Detail II-4

Figure 1.4 Typical Monitoring Point Construction Detail II-6

Figure 1.5 Schematic of Blower System for Air Injection II-7

Figure 3.1 Respiration Test Results at VW II-15

Figure 3.2 Respiration Test Results at MPA-8 II-16

Figure 3.3 Respiration Test Results at MPB-8 II-17

LIST OF TABLES

Table 2.1 Soil and Soil Gas Laboratory Analytical Results II-9

Table 3.1 Initial Soil Gas Chemistry II-10

Table 3.2 Maximum Pressure Response During the
Air Permeability Test II-12

Table 3.3 Influence of Air Injection at Vent Well on Monitoring
Point Oxygen Levels II-13

Table 3.4 Oxygen Utilizaion Rates II-18

PART II
DRAFT INTERIM BIOVENTING PILOT TEST
RESULTS REPORT FOR
BULK FUEL STORAGE AREA 1599
FORT DRUM, NEW YORK

An initial bioventing pilot test was performed by Parsons Engineering Science, Inc. (Parsons ES), at the Bulk Fuel Storage Area 1595 at Fort Drum, New York during the period of 27 June 1994 to 15 July 1994. The purpose of this Part II report is to describe the results of the initial pilot test and to make specific recommendations for extended testing to determine the long-term impact of bioventing on site contaminants. Descriptions of the history, geology, and site contaminants are contained in Part I, the Pilot Test Work Plan.

1.0 PILOT TEST DESIGN AND CONSTRUCTION

In accordance with the Pilot Test Work Plan (Part 1), one vertical air injection vent well (VW) and three multiple-depth soil vapor monitoring points (MPA, MPB, and MPC) were installed during the week of 4 July 1994. A 1-horsepower regenerative blower capable of injecting 30 to 90 standard cubic feet per minute (scfm) was installed at the VW to provide the necessary air for the bioventing test. Figure 1.1 depicts the locations of the VW, MPs, and blower at Area 1595. The hydrogeology of Area 1595 is depicted on the profile in Figure 1.2. The following sections describe in more detail the final design and installation of the bioventing system.

1.1 Vent Well Construction

The VW was installed on 6 July 1994, in an area of documented high total petroleum hydrocarbon (TPH) contamination. The VW was constructed of 4-inch-diameter Schedule 40 polyvinyl chloride (PVC) with a slot size of 0.04 inch. The total depth of the VW was 15 feet below ground surface (bgs), with a screened interval from 5 to 15 feet bgs. The annular space between the well casing and the borehole was filled with 6-9 silica sand from the bottom of the borehole to approximately 4 feet bgs. Granular bentonite was placed above the sand pack from 4 feet bgs to 2 feet bgs and hydrated in place with potable water. The VW was finished with a 2-foot layer of cement/bentonite grout and a 12-inch flush-mount protective well cover. The well cover was cemented in place with the cement/bentonite grout. A detail of the VW construction is presented on Figure 1.3.

1.2 Soil Vapor Monitoring Points

Three soil monitoring points (MPs) were installed at distances of 10, 20, and 40 feet away from the air injection VW (Figure 1.1). Each MP was constructed to



AREA 1595 FUEL STORAGE AREA

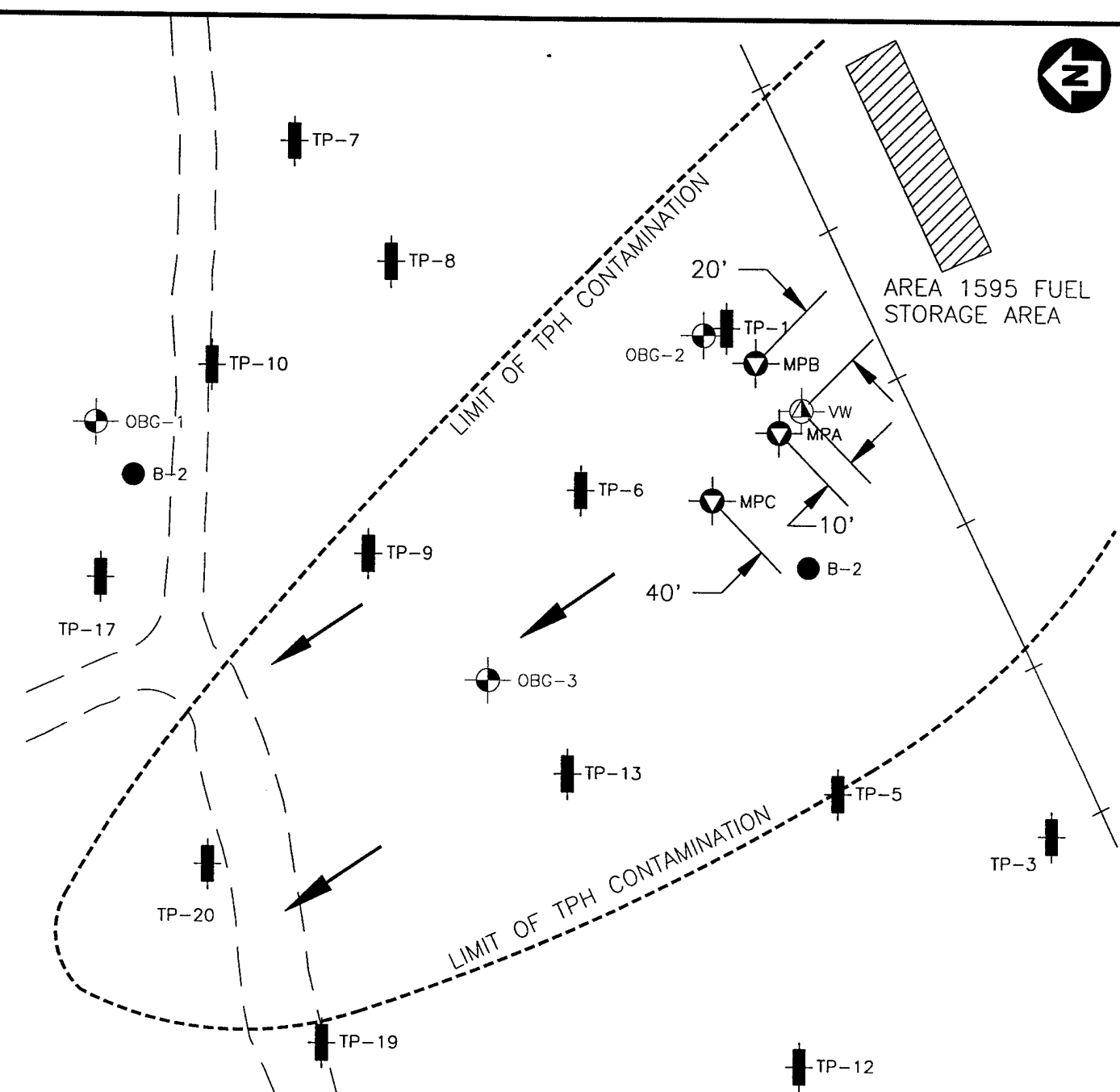

LEGEND

- VENT WELL LOCATION
- VAPOR MONITORING POINT LOCATION
- EXISTING GROUNDWATER MONITORING WELL
- TEST PIT LOCATION
- SOIL BORING LOCATION
- ESTIMATED DIRECTION OF GROUNDWATER FLOW

NOTE

BACKGROUND MONITORING AND SOIL SAMPLING CONDUCTED AT GROUNDWATER MONITORING WELL OBG-4, LOCATED APPROXIMATELY 150' EAST OF TP-7.

FIGURE 1.1

BIOVENTING PILOT TEST STUDY AREA

AREA 1595 FORT DRUM, NEW YORK

ENGINEERING-SCIENCE DESIGN * RESEARCH * PLANNING SYRACUSE, NEW YORK

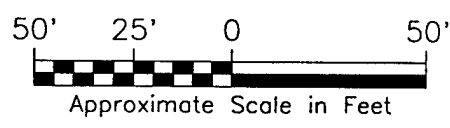

DATE: 11/18/94
H:\CAD\722409\DRUM\FORTDGO1.DWG

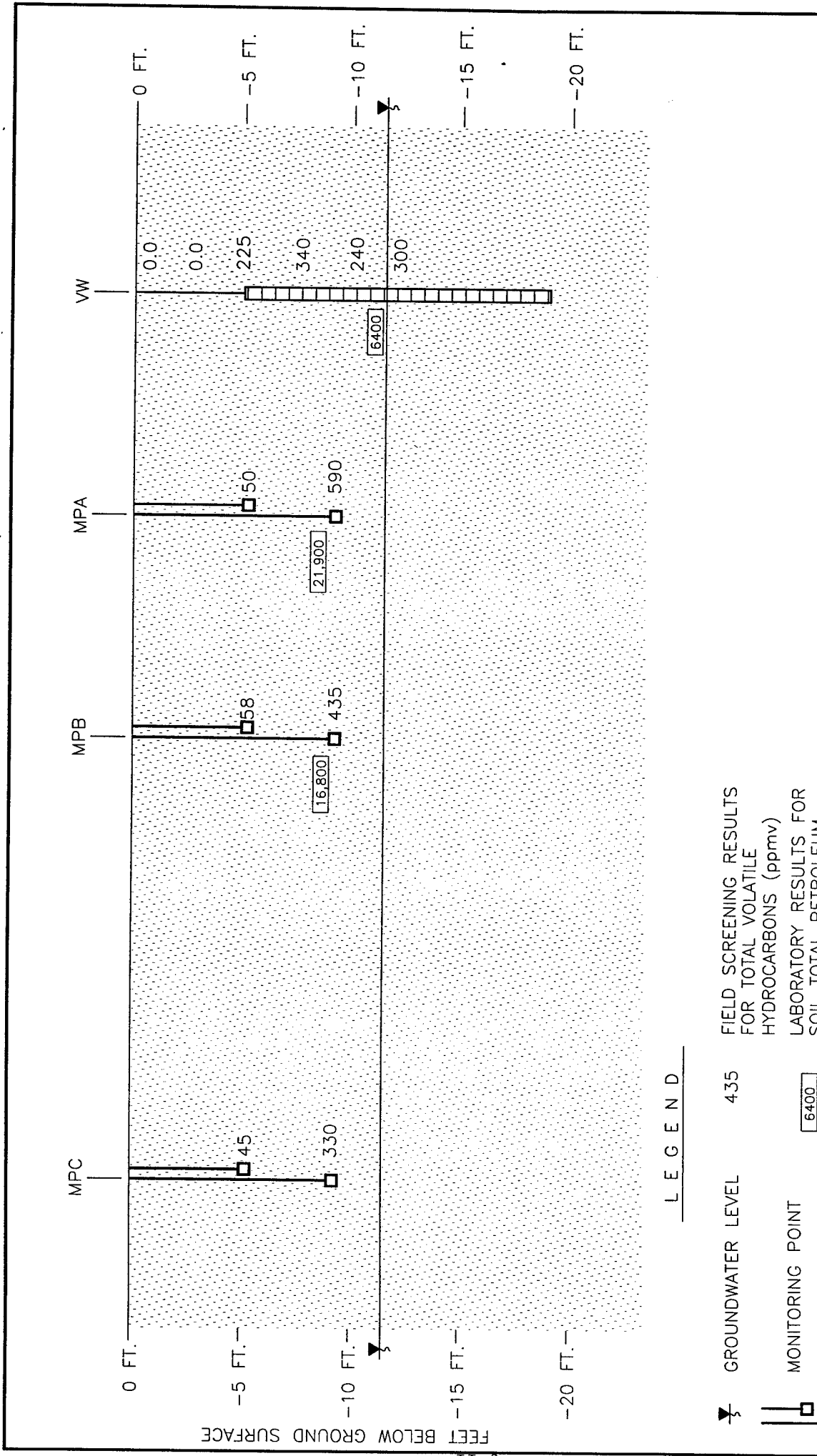
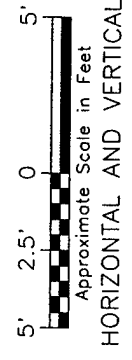

FIGURE 1.2

HYDROGEOLOGIC PROFILE
BIOVENTING TEST AREA

AREA 1595
FORT DRUM, NEW YORK

ENGINEERING-SCIENCE
DESIGN • RESEARCH • PLANNING
STRACUSE, NEW YORK



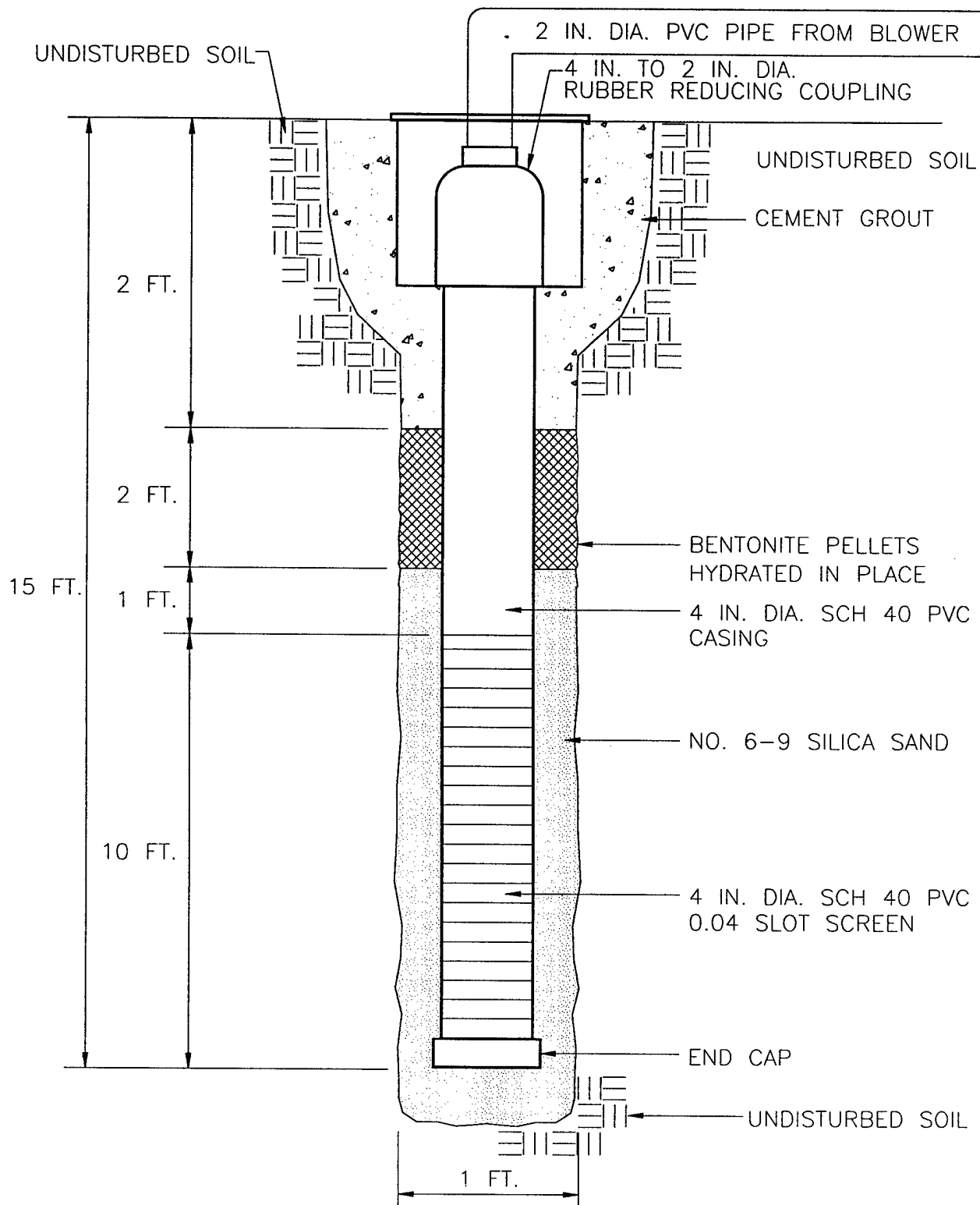

NOT TO SCALE

FIGURE 1.3

AIR INJECTION VENT WELL
CONSTRUCTION DETAIL

AREA 1595
FORT DRUM, NEW YORK

ENGINEERING-SCIENCE
DESIGN * RESEARCH * PLANNING
SYRACUSE, NEW YORK

ES

provide multiple-depth soil gas monitoring, with depth intervals of approximately 4 to 5.5 feet bgs, and 7 to 9 feet bgs at each location. Each discrete point was constructed of a 6-inch long section of 0.5-inch-diameter Schedule 40 PVC well screen with 0.02-inch slot size. The riser of each discrete point was constructed of 0.5-inch Schedule 80 PVC, which extended to approximately 3 feet above the ground surface.

Clean 6-9 silica sand was placed around each discrete point to provide a filter pack between the borehole wall and the point. Granular bentonite was placed both below and above each discrete point to provide an air-tight seal between the points. The bentonite was placed in 12-inch lifts and hydrated in place to assure the proper seal. The top of each riser was fitted with a 0.25-inch quarter-turn ball valve and 3/16-inch hose barb to allow for connection of appropriate monitoring instruments.

Additionally, Type K thermocouples with miniconnectors were installed at the 7- to 9-foot and 4- to 5.5-foot bgs discrete monitoring points in the MP closest to the VW (MPA). These thermocouples were used to measure the soil temperature profile at the site. The top of each MP was completed with a 8-inch aboveground protective well cover set in a concrete base. Figure 1.4 shows the construction of the soil vapor monitoring points.

Background soil gas monitoring was conducted at a previously installed groundwater monitoring well located approximately 300 feet northeast of the test area. This well was installed in uncontaminated soil, and has a screen interval extending from 3 feet bgs to 13 feet bgs. Approximately 5 feet of screen is above the water table at this well.

1.3 Blower Unit Installation

A 1-horsepower Gast® regenerative blower unit was installed at the Area 1595 site for the extended pilot test. The blower was installed in a weather-resistant enclosure and electrically wired for permanent 240-volt, 30-amp service. Air from the blower is injected into the VW via a 2-inch PVC line connected to the blower exhaust port. A schematic diagram of the blower unit and installation is presented on Figure 1.5.

Prior to departing from the site, the Parsons ES engineer provided an operations and maintenance (O&M) briefing, O&M checklist, and blower maintenance manual to the base point of contact. A copy of the O&M checklist is provided in Appendix A.

2.0 PILOT TEST SOIL AND SOIL GAS SAMPLING RESULTS

2.1 Soil and Soil Gas Sampling Results

Based on earlier investigative work, the soils at Area 1595 consist from the ground surface downward of sand (5 to 11 feet thick), marine clay (0 to 2 feet thick), and glacial till (7 to 13 feet thick). Medium-grained brown sand was the only soil type encountered during the installation of the VW and MPs. Bedrock was not encountered during the installation of the VW and MPs. Groundwater was measured at approximately 12 feet bgs during the pilot test.

Hydrocarbon contamination at the site appears to extend from approximately 4 feet bgs to the groundwater table. Contaminated soils collected using split spoons during the VW and MP installations were identified based on appearance,

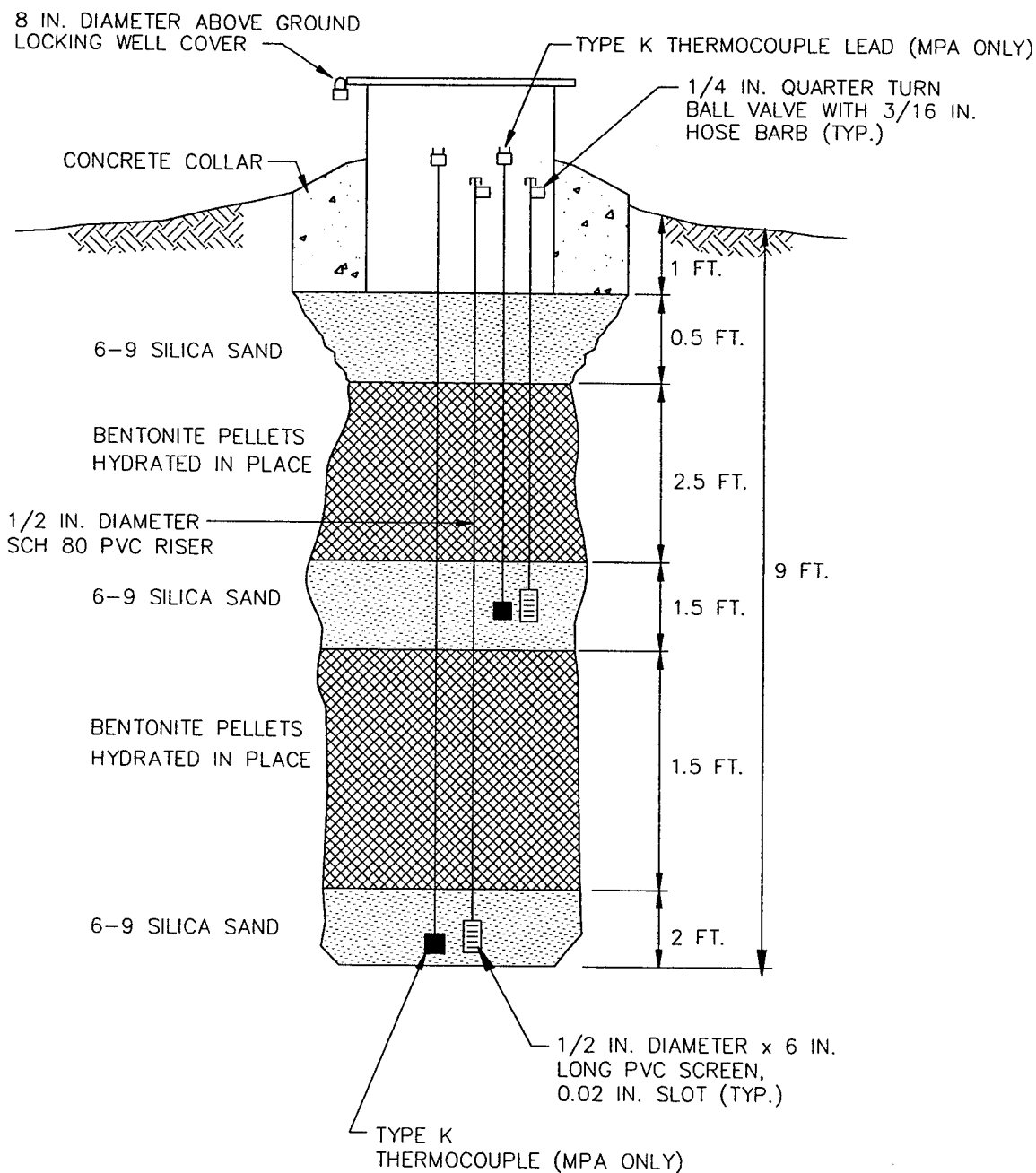

NOT TO SCALE

FIGURE 1.4

TYPICAL MONITORING POINT
CONSTRUCTION DETAIL

AREA 1595
FORT DRUM, NEW YORK

ENGINEERING-SCIENCE
DESIGN * RESEARCH * PLANNING
SYRACUSE, NEW YORK

ES

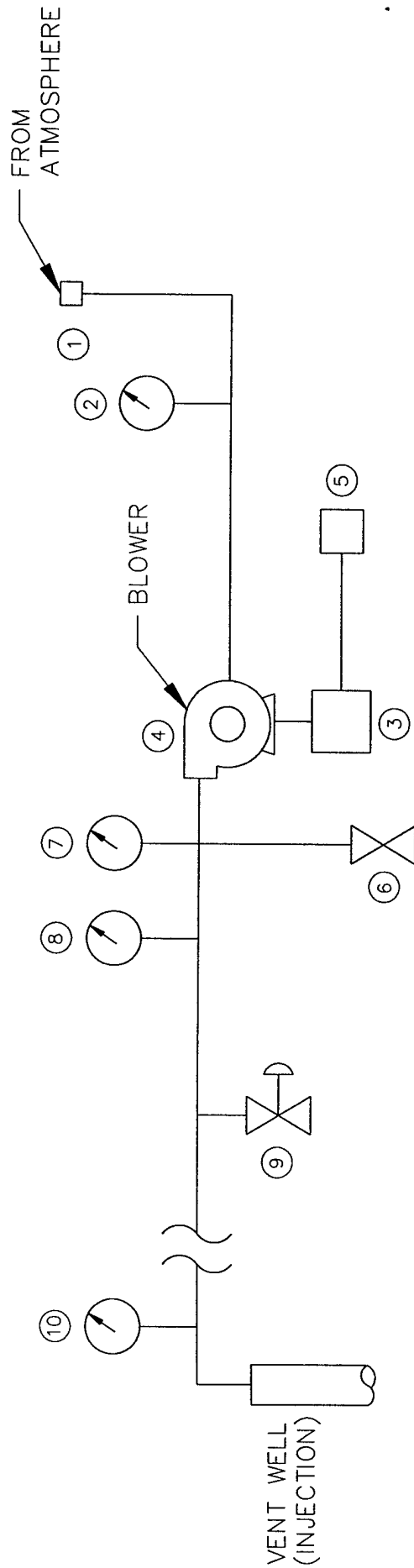

- ① INLET FILTER
- ② VACUUM GAUGE - INCHES OF H₂O
- ③ DRIVE MOTOR
1.0 HP / 3450 RPM @ 60 Hz / 230 v / SINGLE PHASE / 11 A
- ④ BLOWER - CAST 4110-N50 / REGENERATIVE
70 SCFM @ 20 INCHES H₂O
- ⑤ START STOP SWITCH
- ⑥ AUTOMATIC PRESSURE RELIEF VALVE - SET @ 45 INCHES H₂O
- ⑦ PRESSURE GAUGE (INCHES OF H₂O)
- ⑧ THERMOMETER (FAHRENHEIT)
- ⑨ MANUAL PRESSURE RELIEF (BLEED) VALVE - 1 1/2" BALL
- ⑩ AIR VELOCITY MEASUREMENT PORT

FIGURE 1.5

SCHEMATIC OF BLOWER
SYSTEM FOR AIR INJECTION

AREA 1595
FORT DRUM, NEW YORK

ENGINEERING-SCIENCE
DESIGN * RESEARCH * PLANNING
SYRACUSE, NEW YORK

ES

odor, and photoionization detector (PID) screening. PID readings ranged from 0 parts per million volume per volume (ppmv) to 590 ppmv.

Soil samples for laboratory analysis were collected in stainless steel split spoons during the VW and MP installations. Procedures for soil sample collection specified in the protocol document (Hinchee et. al., 1992) were followed for all sample collections. Samples were collected from the 8- to 10- foot interval in the VW and from the 7- to 9-foot intervals in MPA and MPB. A soil sample was also collected from the 4-to 6-foot interval in a soil boring completed near an existing groundwater monitoring well installed in uncontaminated soil (Figure 1.1) for soil moisture and background total Kjeldahl nitrogen (TKN) analysis. All split-spoon samples were field screened for volatile organic compounds (VOCs) by use of the PID to determine the presence of hydrocarbon contamination and to select samples for laboratory analysis.

Soil gas samples were collected prior to the *in situ* respiration test in laboratory-provided, evacuated SUMMA® canisters. Soil gas samples were collected from the VW and the 7- to 9- foot bgs discrete sampling plans at MPA and MPB. All soil gas samples were collected following procedures in the protocol document.

The soil samples for laboratory analysis were placed in a cooler on ice and shipped via Federal Express® to the PACE, Inc., laboratory in Huntington Beach, California. Each soil sample was analyzed for total recoverable petroleum hydrocarbons (TRPH); benzene, ethylbenzene, toluene, and xylenes (BTEX); iron; alkalinity; TKN; pH; phosphates; percent moisture; and grain size distribution. Soil gas samples were placed in a shipping box (without ice), and shipped via Federal Express® to Air Toxics, Inc., in Folsom, California for total volatile hydrocarbons (TVH) and BTEX analysis. The analytical results for the soil and soil gas samples are presented in Table 2.1.

2.2 Exceptions to Test Protocol Document Procedures

No exceptions to the test protocol document procedures were conducted during the initial bioventing pilot test at the BFSa site.

2.3 Field QA/QC Results

Field quality assurance/quality control (QA/QC) samples were not collected or required at this site because the 10-percent collection requirement for QA/QC duplicate samples has been met at other AFCEE bioventing test sites.

3.0 PILOT TEST RESULTS

3.1 Initial Soil Gas Chemistry

Prior to initiating any air injection, soil gas in the VW, MPs and the background monitoring well was monitored for TVH, oxygen, and carbon dioxide. The VW, MPs and monitoring well were purged to remove stagnant soil gas prior to monitoring. Soil gas monitoring was accomplished using portable gas analyzers, as described in the protocol document (Hinchee et al., 1992). The results of the initial monitoring are presented in Table 3.1.

As shown in Table 3.1, the VW and the deeper monitoring points (i.e. the 8 feet bgs points) in the three MPs exhibited depleted oxygen levels (0 % to 11 %), elevated

TABLE 2.1
SOIL AND SOIL GAS LABORATORY ANALYTICAL RESULTS
AREA 1595 FUEL STORAGE AREA
Fort Drum, New York

Analyte (Units) ^a	Sample Location – Depth (feet below ground surface)		
	VW	MPA-8	MPB-8
<u>Soil Gas Hydrocarbons</u>			
TVH (ppmv)	1800	3100	1900
Benzene (ppmv)	<0.1	<0.51	<0.27
Toluene (ppmv)	4.9	9.8	6.8
Ethylbenzene (ppmv)	2.7	2.4	3
Xylenes (ppmv)	15	15	18
<u>Soil Hydrocarbons</u>			
	VW-8-10	MPA-7-9	MPB-7-9
TRPH (mg/kg)	6400	21900	16800
Benzene (mg/kg)	<2.9	<2.8	<2.7
Toluene (mg/kg)	<2.9	<2.8	<2.7
Ethylbenzene (mg/kg)	4.4	4.4	<2.7
Xylenes (mg/kg)	26	30	19
<u>Soil Inorganics</u>			
Iron (mg/kg)	3770	3400	6840
Alkalinity (mg/kg as CaCO ₃)	<46	<44	<42
pH (units)	6.1	5.8	5.7
TKN (mg/kg)	20	52	55
Phosphates (mg/kg)	<10	<10	<10
<u>Soil Physical Parameters</u>			
Soil Temperature (°F MPA-S & MPA-D)	(54.8 & 59.0)		
Moisture (% wt.)	14.4	10.3	7.1
Gravel (%)	0	0	0
Sand (%)	98.2	97.6	97.5
Silt (%)	0.1	0.7	0.8
Clay (%)	1.7	1.7	1.7

^a TRPH = total recoverable petroleum hydrocarbons; TVH = total volatile hydrocarbons; mg/kg = milligrams per kilogram; ppmv = parts per million by volume; CaCO₃ = calcium carbonate; TKN = total Kjeldahl nitrogen.

TABLE 3.1
INITIAL SOIL GAS CHEMISTRY
AREA 1595
Fort Drum, New York

Sample Location	Sample Depth (ft)	O ₂ (%)	CO ₂ (%)	TVH (ppmv)
VW	5-10	5.8	9.3	2400
MPA	5	15.2	4	700
MPA	8	0	12.8	4200
MPB	5	15	4.4	220
MPB	8	0	14	3600
MPC	5	18	2.2	230
MPC	8	11	5.2	2000
BKG	3	20.5	0.8	18

NS: Sample could not be collected due to a flooded monitoring point screen

carbon dioxide readings (5.2 % to 14 %), and TVH readings ranging from 2,000 ppmv to 4,200 ppmv. In contrast, the soil gas monitoring conducted at the background monitoring well indicated near atmospheric conditions with concentrations of 20.8% oxygen, 0.25% carbon dioxide, and 10 ppmv TVH. These readings suggest that the indigenous microorganisms have depleted much of the naturally available oxygen supply in contaminated soils below approximately 5 feet bgs and indicate the presence of significant biological activity. The shallower monitoring points (i.e. 5 feet bgs points) at the three MPs did not appear to be as impacted by hydrocarbon contamination and the deeper points. The soil gas concentrations in these points ranged from 15 % to 18 % oxygen, 2.2 % to 4.4 % carbon dioxide, and 220 ppmv to 700 ppmv TVH. These readings are likely caused by oxygen diffusion in the high permeability soils found at Area 1595.

3.2 Air Permeability

An air permeability test was conducted according to protocol document procedures on 25 July 1994. Air was injected into the VW for 2 hours during the permeability test at a rate of approximately 60 scfm and an average pressure of 30 inches of water. Steady-state pressure levels were achieved at all the MPs within the two hour permeability test. Table 3.2 provides the maximum pressures at each discrete monitoring point.

Because steady-state pressure levels were achieved at all MPs during the 2-hour permeability test, the steady-state method was utilized to calculate the soil permeability. Based on this calculation, the site soils have an air permeability of approximately 35 darcy units. This value is typical of high permeability soils such as those at Area 1595.

3.3 Oxygen Influence

The depth and radius of oxygen influence in the subsurface resulting from air injection into the VW is the primary design parameter for bioventing systems. Optimization of full-scale and multiple VW systems require pilot testing to determine the volume of soil that can be oxygenated at a given flow rate and vent well screen configuration.

Table 3.3 presents the change in soil gas oxygen levels that occurred after 6 hours of continuous air injection. This test was conducted concurrently with the air permeability test, and was continued for 4 hours after the conclusion of the 2-hour permeability test. The 6 hours of air injection, at approximately 60 scfm, produced changes in soil gas oxygen concentrations at least 40 feet from the VW. Based on the soil gas chemistry changes and the pressure responses at MPB, the long term radius of oxygen influence will exceed 40 feet when air is injected at a rate of approximately 60 scfm.

3.4 *In Situ* Respiration Rates

In Situ respiration tests were performed at the VW, and at MPA and MPB at the 8-foot bgs monitoring points. The points were chosen based on their low initial soil gas oxygen readings (0 to 5.8%), high initial carbon dioxide readings (9.3 to 14%), and high initial TVH readings (2,400 to 4,200 ppmv). A 4-percent helium in air mixture was injected into each of the three discrete MPs for 23 hours during the initial part of

TABLE 3.2
 MAXIMUM PRESSURE RESPONSE DURING THE
 AIR PERMEABILITY TEST
 AREA 1595
 Fort Drum, New York

	Distance from VW					
	10' (MPA)		20' (MPB)		40' (MPC)	
Depth (feet bgs)	5	8	5	8	5	8
Time (minutes)	120	120	120	120	120	120
Max Pressure (inches H ₂ O)	0.49	2.3	0.06	0.2	0.01	0.02

TABLE 3.3
INFLUENCE OF AIR INJECTION AT VENT WELL
ON MONITORING POINT OXYGEN LEVELS
AREA 1595
Fort Drum, New York

Monitoring Point Locations	Distance From VW (ft)	Depth (ft)	Initial O ₂ (%)	Final O ₂ (%) Permeability Test
MPA	10	5	15.2	20.7
MPA	10	8	0.0	20.1
MPB	20	5	15.0	15.1
MPB	20	8	0.0	17.0
MPC	40	5	18.1	18.1
MPC	40	8	11.5	10.1

the *in situ* respiration test. Oxygen, carbon dioxide, TVH, and helium concentrations were then measured in the soil gas at each discrete MP. These readings were collected for approximately 116 hours following cessation of the helium/air injection period. The measured oxygen losses were then used to calculate biological oxygen utilization rates. The results of the *in situ* respiration testing for VW, MPA-8 and MPB-8 points are presented in Figures 3.1, 3.2, and 3.3. Table 3.4 provides a summary of the calculated oxygen utilization rates.

Because helium is a conservative, inert gas, the change in helium concentration over time can be useful in determining the effectiveness of the bentonite seals between each discrete sampling point in the MPs. Figures 3.1 through 3.3 compare oxygen utilization and helium retention. As shown on these figures, the helium concentrations in the 8-foot bgs monitoring points in MPA and MPB decreased at approximately the same rate as the oxygen. The helium concentration in the VW decreased at approximately twice the rate of oxygen loss. Because helium will diffuse into a given medium approximately three times faster than oxygen due to helium's lower molecular weight, the oxygen loss at the MPA and MPB 8-foot bgs monitoring points is primarily the result of bacterial respiration. Oxygen loss at the VW appears to be a combination of bacterial respiration and diffusion, and the results at this point are suspect.

Based on the results of the respiration test at the 8-foot bgs monitoring points at MPA and MPB, an estimated 500 to 600 mg of fuel per kilogram of soil can be biodegraded each year at Area 1595. The interval-specific fuel consumption rates were calculated using observed oxygen utilization rates (Table 3.4), estimated air-filled soil porosities, and a conservative ratio of 3.5 mg oxygen consumed for every 1 mg of fuel biodegraded. The calculated air-filled porosities were 0.091 and 0.124 liter air per kilogram of soil for the 8-foot bgs monitoring points at MPA and MPB, respectively.

3.5 Potential Air Emissions

The potential for long-term VOC emissions into the atmosphere from full-scale bioventing operations at Area 1595 are considered to be low because of the low volatility diesel fuel contamination and low rates of air injection that will be used at this site. Additionally, a recent ground surface emission flux test was conducted at an Air Force Base (Plattsburgh AFB, New York, 1993) with similar contaminants and soil type. Results of this test showed an emission rate of less than 0.002 pound of benzene per day. Health and safety monitoring conducted at this time during the 6-hour air permeability test/oxygen influence monitoring, using a PID sensitive to 1 ppmv, did not detect any hydrocarbons either in the breathing zone or at the ground surface. Because the potential for air emissions is highest during the initial air injection period, and no emissions were detected, the long-term VOC emission potential is considered low.

4.0 RECOMMENDATIONS

Initial bioventing testing at Area 1595 at Fort Drum indicate that oxygen has been depleted in the contaminated soils, and that air injection will be an effective method of increasing aerobic fuel biodegradation. AFCEE has recommended that air injection begin at the Area 1595 site to determine the long-term radius of oxygen influence and

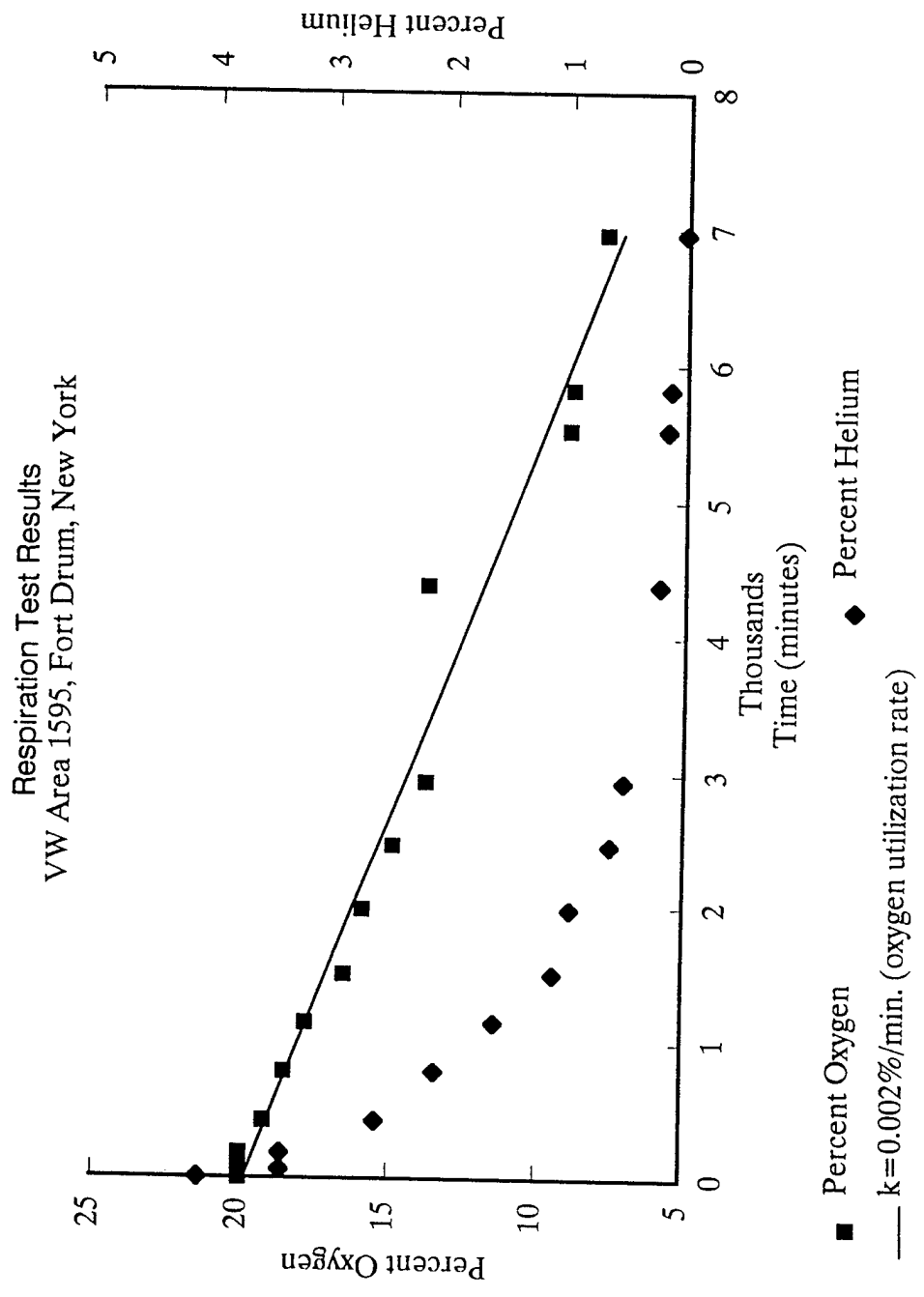
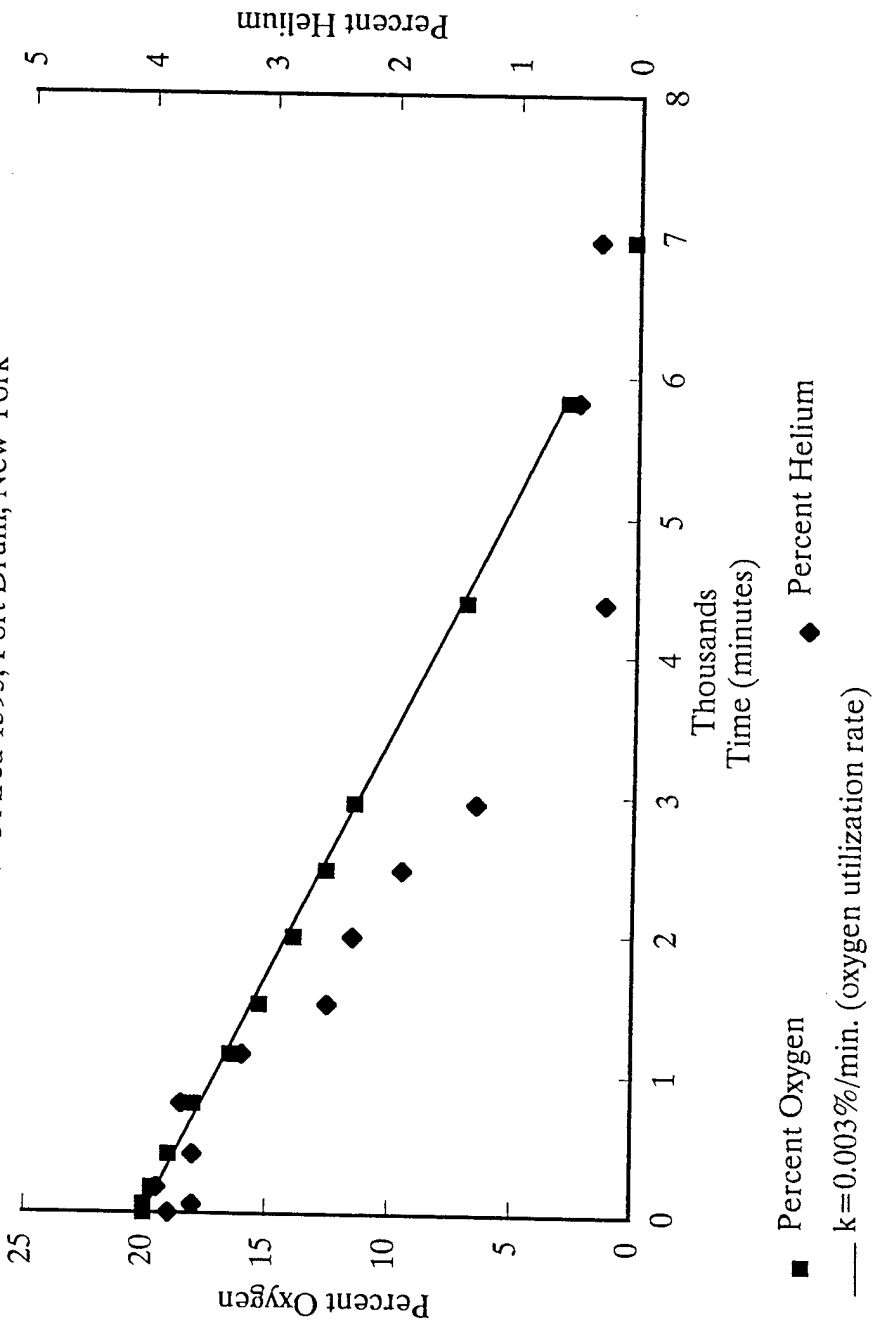

FIGURE 3.2

Respiration Test Results
MPA-8 Area 1595, Fort Drum, New York



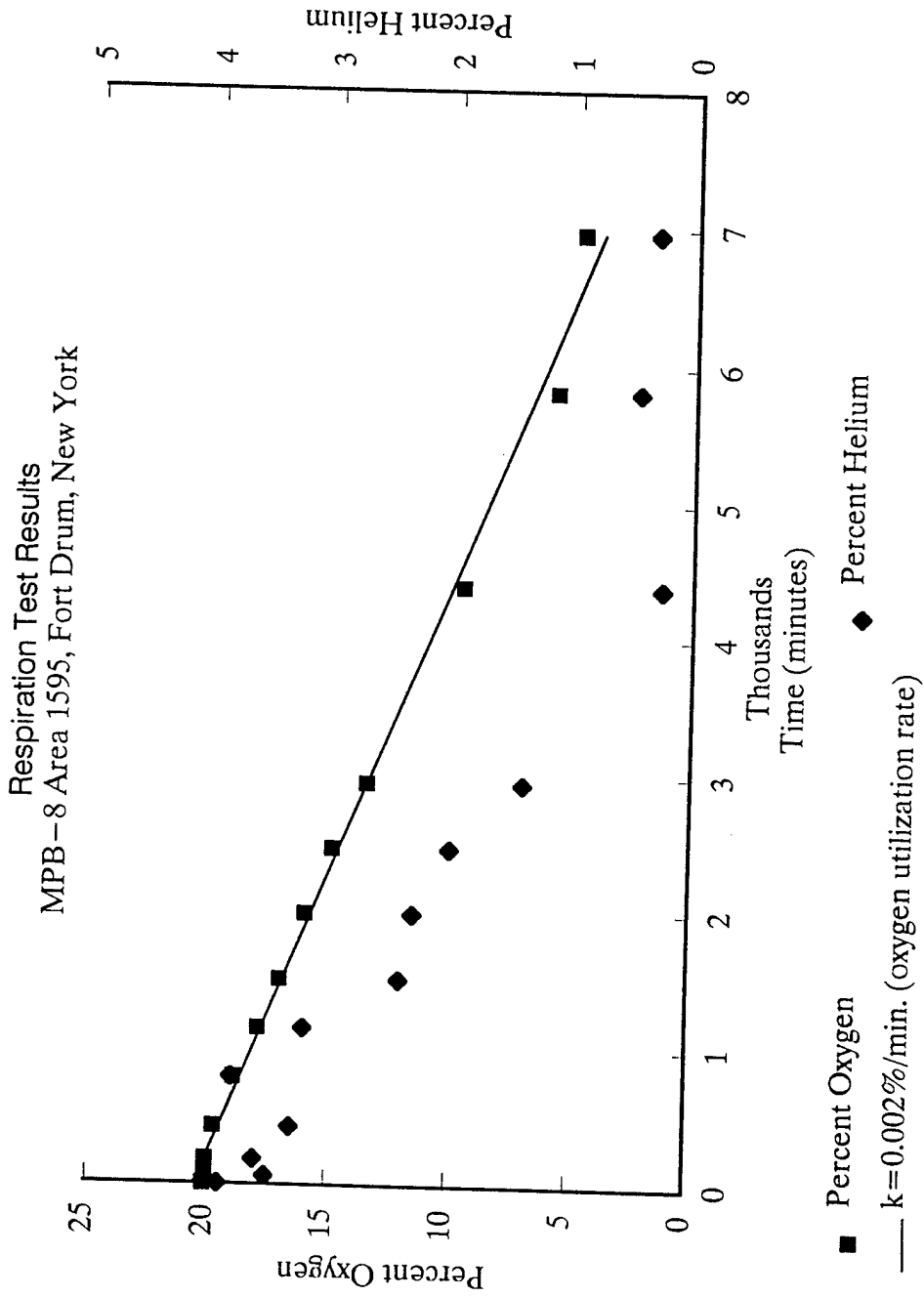

TABLE 3.4
OXYGEN UTILIZATION RATES
AREA 1595
Fort Drum, New York

Monitoring Point	O2 Loss* (%)	Test Duration (min)	O2 Utilization Rate* (% per min)
VW	12.2	6960	0.0018
MPA-8	19.8	6960	0.0026
MPB-8	15.3	6960	0.0023

* Values based on linear regression (Figures 3.1 through 3.3)

the effects of time, available nutrients and changing temperatures on fuel biodegradation rates.

A 1-horsepower regenerative blower has been installed at Area 1595 to inject air at a rate of approximately 40 scfm. This blower was installed to allow for expansion of the bioventing system to include multiple air injection VWs to remediate an even larger area if necessary in the future. Because the 1-year test period began on 30 October 1994, Parsons ES will return to the base during April and October 1995 to analyze the soil gas and to conduct follow-up *in situ* respiration tests. Additionally, during the October 1995 site visit, Parsons ES will collect a limited number of soil samples from the test site to determine the soil contamination levels after 1 year of *in situ* treatment.

Based on the results of the first year of pilot-scale bioventing, AFCEE will recommend one of three options for the Area 1595 site:

1. Upgrade, if necessary, and continue operation of the bioventing system.
2. If the one year soil samples indicate that significant contamination removal has occurred. AFCEE may recommend additional soil sampling to confirm that the cleanup criteria has been achieved.
3. If significant difficulties or poor results are encountered during the bioventing pilot test. AFCEE may recommend removal of the blower system and proper abandonment of the VW and MPs.

5.0 REFERENCES

Engineering-Science, Inc. 1994. *Draft Bioventing Test Work Plan for Area 1595 Fuel Storage Area, Fort Drum, New York*. May.

Hinchee, R.E., Ong, S.K., Miller, R.N., Downey, D.C., Frandt, R. 1992 *Test Plan and Technical Protocol for a Field Treatability Test for Bioventing*. Columbus, Ohio. January.

Engineering-Science, Inc. 1993. *Final Flux Test Results, Plattsburgh AFB, New York*. September.

APPENDIX A
REGENERATIVE BLOWER
OPERATIONS AND MAINTENANCE MANUAL
FOR
EXTENDED TESTING SYSTEM AT
AREA 1595 FUEL STORAGE AREA
FORT DRUM, NEW YORK

Prepared for

Air Force Center for Environmental Excellence
Brooks AFB, Texas

and

Directorate of Engineering and Housing
Engineering Division
Fort Drum, New York

by

Engineering-Science, Inc
290 Elwood Davis Road
Liverpool, New York

October 1994

TABLE OF CONTENTS

Section 1 Introduction.....	1-1
Section 2 Bioventing System Operation	2-1
2.1 Principle of Operation.....	2-1
2.2 System Description	2-1
2.2.1 Blower System.....	2-1
2.2.2 Monitoring Gauges.....	2-1
Section 3 System Maintenance	3-1
3.1 Blower/Motor Maintenance	3-1
3.1.1 Lubrication.....	3-1
3.2 Air Filter Maintenance	3-1
3.3 Maintenance Schedule.....	3-2
3.4 Major Repairs	3-2
Section 4 System Monitoring.....	4-1
4.1 Blower Performance Monitoring	4-1
4.1.1 Vacuum/Pressure.....	4-1
4.1.2 Flow Rate	4-1
4.1.3 Temperature.....	4-1
4.3 Monitoring Schedule	4-1

SECTION 1

INTRODUCTION

This document has been prepared by Engineering-Science, Inc. to support the bioventing initiative contract awarded by the Air Force Center for Environmental Excellence. The contract involves the conducting of bioventing pilot tests at Air Force bases across the United States.

At most sites, bioventing systems will be installed upon completion of the bioventing pilot tests for the purpose of extended pilot testing. These systems will operate for a one year period to provide further information as to the feasibility of the technology at each site, and to provide interim remedial action.

This Operations and Maintenance Manual has been created for sites at which regenerative type blowers have been installed for extended pilot testing. Basic maintenance of these systems is the responsibility of the base. The manual is to be used by base personnel to guide and assist them in operating and maintaining the blower system. Section 2 of this document describes the blower. Section 3 details the maintenance requirements and provides maintenance schedules. Section 4 describes the system monitoring that is required to forecast system maintenance needs and provide data for the extended pilot test. Blower performance curves and relevant service information are provided in Appendix A, and data collection sheets are provided in Appendix B.

SECTION 2

BIOVENTING SYSTEM OPERATION

2.1 PRINCIPLE OF OPERATION

Bioventing is the forced injection of fresh air, or withdrawal of soil gas, to enhance the supply of oxygen for in-situ bioremediation. Either a pressure (air injection) or vacuum (vapor extraction) blower unit is used to inject or withdraw air into or from the soil, thereby supplying fresh air with 20.9 percent oxygen to contaminated soils. Once oxygen is provided to the subsurface, existing bacteria will proceed with the breakdown of fuel residuals.

At Fort Drum, a 2¹/₂ horsepower blower system has been installed.

2.2 SYSTEM DESCRIPTION

2.2.1 Blower System

A GAST R5125-1 blower powered by a 2¹/₂ horsepower direct-drive motor is the workhorse of the bioventing system. This blower is rated at 140 scfm at 10 inches of water vacuum; however, the actual performance of the blower will vary with changing site conditions. All systems include an air filter to remove any particulates which are entrained in the air stream and several valves and monitoring gauges which are described in the next section. A schematic of the blower system installed at Fort Drum, corresponding blower performance curves, and relevant service information are provided in Appendix A.

2.2.2 Monitoring Gauges

The bioventing system is equipped with vacuum and pressure gauges and a temperature gauge. Gauges have been installed on the air injection system at the following locations; a vacuum gauge in the inlet piping and a pressure gauge in the outlet piping. See the system schematic for the locations of the gauges installed on the blower system at this site.

A temperature gauge is located at the outlet of the blower system. This gauge is used to monitor the outlet temperature from the blower. Ambient air temperature should be used to determine the inlet temperature. See the system schematic for the location of the temperature gauge installed on the blower system at this site.

SECTION 3

SYSTEM MAINTENANCE

3.1 BLOWER/MOTOR MAINTENANCE

Although the motor is relatively maintenance free, the system requires periodic maintenance for proper operation and long life. Recommended maintenance procedures and schedules are described in detail in the instruction manual included in Appendix A and briefly summarized in this section. The blower and motor should not require any periodic maintenance during the 1-year extended testing period.

Filter inspection must be performed with the system turned off. To re-start the motor, open the manual bypass valve to protect the motor from excessive strain, start motor, and slowly close bypass valve to its original setting. If the handle has been removed from the manual air dilution valve, do not open the valve or otherwise change the setting (it has been pre-set for a specific flow rate) before re-starting the blower.

3.1.1 Lubrication

Regenerative blowers require no lubrication.

3.2 AIR FILTER MAINTENANCE

To avoid damage caused by passing solids through the blower an air filter has been installed in-line before the blower.

The filter element is paper and is accompanied by a polyurethane foam prefilter. The filter should be checked weekly for the first two months of operation. Again, a base employee should determine the best schedule for filter replacement. The polyurethane prefilters can be washed with lukewarm water and a mild detergent. Paper filter elements should never be washed but should be disposed of and replaced as necessary. When the pressure or vacuum drop across the filter is above 15 inches of water, a dirty filter element should be suspected and cleaning or replacement should be performed.

To remove the filter, loosen the three clamps or the wing nut, lift the metal top off the air filter, and lift the air filter from the metal housing. Remove the polyurethane prefilter (if applicable) and wash before replacing. When replacing the filter, be careful that the rubber seals remain in place.

The filter is manufactured by Solberg Manufacturing, Inc. in Itasca, Illinois. Their telephone number is (708) 773-1363. Additional filters can also be obtained through Engineering-Science, Inc. in Liverpool, New York. The ES contacts are Mr. David Brown and Mr. Richard Moravec and they can be reached at (315) 451-9560.

3.3 MAINTENANCE SCHEDULE

The following maintenance schedule is recommended for this system. During the initial months of operation more frequent monitoring is recommended to ensure that any start up problems are quickly corrected. A daily drive-by inspection is

recommended during the initial two weeks of operation to ensure that the blower system is still operating with no unusual sounds. Data collection sheets have been provided to assist your data collection and are included in Appendix B.

Maintenance Item

Maintenance Frequency

Filter

Check once per month. Wash or replace as necessary.

3.4 MAJOR REPAIRS

Blower systems are very reliable when properly maintained. Occasionally, a motor or blower will develop serious problems. If a blower system fails to start, and a base electrician verifies that power is available at the starter, the Engineering-Science site manager, Dave Brown, should be called at (315) 451-9560. Engineering-Science is responsible for major repairs during the first year of operation.

SECTION 4

SYSTEM MONITORING

4.1 BLOWER PERFORMANCE MONITORING

To monitor the blower performance, vacuum, pressure and temperature will be measured. These data should be recorded weekly on a data collection sheet provided in Appendix B. All measurements should be taken at the same time while the system is running. Since the System is loud, ear protection should be worn at all times.

4.1.1 Vacuum/Pressure

With ear protection on, record all vacuum and pressure readings directly from the gauges (in inches of water). Record the measurements on the data collection sheet provided in Appendix B.

4.1.2 Flow Rate

The flow rate through the vent well and soils can be calculated when the inlet vacuum and outlet pressure of the blower are known. This pressure change across the blower (vacuum + pressure) can be compared to the performance curves for the blower in Appendix A to determine the approximate flow rate.

4.1.3 Temperature

With ear protection on, record the temperature readings directly from the gauge in degrees Fahrenheit. Record the measurements on the data collection sheet provided in Appendix B. The temperature change can be converted to degrees Celsius ($^{\circ}\text{C}$) using the formula $^{\circ}\text{C} = (^{\circ}\text{F} - 32) \times 5/9$.

4.3 MONITORING SCHEDULE

The following monitoring schedule is recommended for this system. During the initial months of operation more frequent monitoring is recommended to ensure that any start up problems are quickly corrected. Data collection sheets have been provided to assist your data collection and are included in Appendix B.

<u>Monitoring Item</u>	<u>Monitoring Frequency</u>
Vacuum/Pressure	Daily during first week, then once per week.
Temperature	Daily during first week, then once per week.