

## **Interfacility Boundary Adjustment**

Jerry Hadley, ACT-540  
Randy Sollenberger, Ph.D., ACT-530  
Jean-Francois D'Arcy, Ph.D., SRC  
Philip Bassett, SATCS ZJX

**DISTRIBUTION STATEMENT A**  
Approved for Public Release  
Distribution Unlimited

July 2000

DOT/FAA/CT-TN00/06

Document is available to the public  
through the National Technical Information  
Service, Springfield, Virginia 22161



U.S. Department of Transportation  
Federal Aviation Administration

William J. Hughes Technical Center  
Atlantic City International Airport, NJ 08405

DTIC QUALITY INSPECTED 4

20001227 056

## **NOTICE**

This document is disseminated under the sponsorship of the U.S. Department of Transportation in the interest of information exchange. The United States Government assumes no liability for the contents or use thereof. The United States Government does not endorse products or manufacturers. Trade or manufacturer's names appear herein solely because they are considered essential to the objective of this report. This document does not constitute FAA certification policy. Consult your local FAA aircraft certification office as to its use.

1. Report No. DOT/FAA/CT-TN00/06		2. Government Accession No.		3. Recipient's Catalog No.	
4. Title and Subtitle Interfacility Boundary Adjustment				5. Report Date July 2000	
				6. Performing Organization Code ACT-530	
7. Author(s) Jerry Hadley, ACT-540, Randy Sollenberger, Ph.D., ACT-530, Jean-Francois D'Arcy, Ph.D., SRC, and Philip Bassett, SATCS ZJX				8. Performing Organization Report No. DOT/FAA/CT-TN00/06	
9. Performing Organization Name and Address Federal Aviation Administration William J. Hughes Technical Center Atlantic City International Airport, NJ 08405				10. Work Unit No. (TRAIS)	
				11. Contract or Grant No.	
12. Sponsoring Agency Name and Address Federal Aviation Administration Human Factors Division 800 Independence Ave., S.W. Washington, DC 20591				13. Type of Report and Period Covered Technical Note	
				14. Sponsoring Agency Code AAR-100	
15. Supplementary Notes					
16. Abstract <p>The objective of the study was to examine the impact of inter-facility dynamic resectorization on Air Traffic Control Specialists' (ATCSs') performance, workload, communication, situational awareness, and control strategies. As a preliminary investigation, the scope of the study was limited to lateral boundary adjustments (in contrast to vertical adjustments) and specific traffic situations that should benefit the most from dynamic resectorization. The researchers selected a heavy traffic situation and shifting weather patterns as scenarios for this investigation. The approach was to pre-define regions of airspace that could be allocated to one Air Route Traffic Control Center (ARTCC) or the other depending upon the traffic situation. This approach represented a simple method of dynamic resectorization that could be implemented using current air traffic control (ATC) equipment. Twelve full performance level controllers participated in the study over a 6-week period. We evaluated their performance using objective and subjective measures. We assessed controller workload using the National Aeronautics and Space Administration Task Load Index and the Air Traffic Workload Input Technique. We measured ATCSs' situation awareness using self-ratings on a numeric scale. In addition, controllers completed questionnaires after each scenario and at the end of the study. The results indicated that dynamic resectorization did not interfere with ATCS performance. Overall, there were very few separation losses in the study. However, the results indicated slightly fewer separation losses for dynamic resectorization in the heavy traffic scenarios, although this trend was not statistically reliable. Finally, the results indicated slightly lower NASA-TLX workload ratings in dynamic resectorization scenarios. However, dynamic resectorization did not reduce controller situation awareness. In fact, controller ratings of situation awareness were higher when operating dynamic resectorization scenarios in both high density traffic and shifting weather situations.</p>					
17. Key Words airspace, Air Route Traffic Control Center, air traffic control, boundary adjustment, en route, resectorization, simulation				18. Distribution Statement This document is available to the public through the National Technical Information Service, Springfield, Virginia, 22161	
19. Security Classif. (of this report) Unclassified		20. Security Classif. (of this page) Unclassified		21. No. of Pages 60	22. Price



## Table of Contents

	Page
Acknowledgements .....	iii
Executive Summary .....	vii
1. Introduction .....	1
1.1 Background .....	1
1.2 Purpose .....	3
1.3 Study Objective and Limitations.....	3
2. Method .....	3
2.1 Participants .....	3
2.2 Equipment .....	4
2.3 Airspace.....	4
2.4 Traffic Scenarios .....	4
2.5 Design .....	5
2.5.1 Independent Variables.....	5
2.5.2 Dependent Variables .....	6
2.6 Procedures .....	7
2.7 Training .....	9
3. Results .....	9
3.1 System Effectiveness Measures .....	10
3.2 SME Ratings .....	14
3.3 Controller Ratings .....	14
3.3.1 NASA Task Load Index .....	14
3.3.2 ATWIT .....	16
3.3.3 Post-Scenario Questionnaire Ratings .....	19
3.3.4 Exit Questionnaire.....	22
4. Discussion and Conclusions.....	23
References .....	27
Appendixes	
A - Informed Consent	
B - Scenario Presentation Order	
C - Subject Matter Expert Observer Rating Form	
D - Questionnaires	
E - Inter-Facility Boundary Adjustment Policies and Procedures	

## List of Illustrations

Figures	Page
1. High-Density Traffic Scenarios .....	6
2. Weather Scenarios.....	6
3. Separation Losses Across Conditions .....	10
4. Airspace Type by Traffic Situation Interaction for Duration of Push-To-Talk Transmissions	12
5. Airspace Type by Traffic Situation Interaction for Number of Land Line Communications..	13
6. Airspace Type by Traffic Situation Interaction for Duration of Land Line Communications	13
7. Airspace Type by Traffic Situation Interaction for Preplanning Control Actions .....	16
8. Mean NASA TLX Scores .....	16
9. Airspace Type by Traffic Situation Interaction for ATWIT Ratings.....	17
10. ATWIT Interval Data for the High Density Traffic Scenario.....	18
11. ATWIT Interval Data for the Weather Scenario.....	18
12. Post-Scenario Questionnaire Ratings of Performance .....	19
13. Post-Scenario Questionnaire Ratings of Situational Awareness.....	20
14. Airspace Type by Traffic Situation Interaction for Overall Coordination.....	21
15. Airspace Type by Traffic Situation Interaction for Difficulty .....	21
Tables	Page
1. System Effectiveness Measures .....	7
2. Observation Rating Form (En Route Environment) .....	8
3. Participant Schedule.....	8
4. <i>F</i> Statistics Obtained From the Two-Way ANOVA Performed on the System Effectiveness Measures.....	11
5. Mean Completed Flights and, <i>F</i> Statistics Obtained from the Analysis of Simple Main Effects .....	11
6. Mean DPTT, <i>F</i> Statistics obtained From the Analysis of Simple Main Effects .....	12
7. Mean NLL and Mean DLL, <i>F</i> Statistics Obtained from the Analysis of Simple Main Effects .....	14
8. Mean NLL and Mean DLL, <i>F</i> Statistics Obtained from the Analysis of Simple Main Effects .....	14
9. <i>F</i> Statistics Obtained From the Two-Way ANOVA Performed on the Observer Ratings .....	15
10. Mean OTS SME Ratings of Preplanning Control Actions, <i>F</i> Statistics Obtained from the Analysis of Simple Main Effects .....	15
11. <i>F</i> Statistics Obtained From the Two-Way ANOVA Performed on NASA TLX and ATWIT Workload Ratings.....	17
12. Mean ATWIT Ratings, <i>F</i> Statistics Obtained from the Analysis of Simple Main Effects ....	17
13. <i>F</i> Statistics Obtained from the Two-Way ANOVA Performed on the Post-Scenario Questionnaire Ratings .....	19
14. Mean-Post Scenario Self-Ratings of Coordination and <i>F</i> Statistics Obtained from the Analysis of Simple Main Effects .....	20
15. Mean Post-Scenario Ratings of Scenario Difficulty and <i>F</i> Statistics Obtained from the Analysis of Simple Main Effects .....	20
16. Post-Scenario Questionnaire Resectorization Ratings .....	22
17. Exit Questionnaire Ratings.....	23

## Executive Summary

Current airspace structure is rigid and does not allow for dynamic resectorization of airspace boundaries. Dynamic resectorization is adaptive and can efficiently handle heavy traffic situations, shifting weather conditions, status changes in special use airspace, and user-preferred routes. Dynamic resectorization has the potential to reduce aircraft delays, decrease fuel consumption, and lower operating costs for the airline industry. The potential benefits for Air Traffic Control Specialists (ATCSs) are to offset heavy workload and reduce coordination and communications. However, dynamic resectorization may be disruptive and could have negative consequences for controller situational awareness and performance. This report describes a real-time human-in-the-loop simulation study designed to investigate a specific approach to implementing dynamic resectorization between two adjacent Air Route Traffic Control Centers (ARTCCs).

The objective of the study was to examine the impact of inter-facility dynamic resectorization on ATCSs' workload, communication, situational awareness, control strategies, and performance. As a preliminary investigation, the scope of the study was limited to lateral boundary adjustments and specific traffic situations that should benefit the most from dynamic resectorization. The researchers selected a heavy traffic situation and shifting weather patterns as scenarios for this investigation. The approach was to predefine regions of airspace that could be allocated to one ARTCC or the other depending upon the traffic situation. This approach represented a simple method of dynamic resectorization that could be implemented using current air traffic control equipment.

A team of human factors researchers and Subject Matter Experts (SMEs) conducted the simulation in the Research Development and Human Factors Laboratory at the Federal Aviation Administration William J. Hughes Technical Center. We developed generic en route airspace for the study that consisted of two adjacent sectors from different ARTCCs. We briefed every controller on the airspace, sector configurations and the standard operating procedures for the generic sectors. We coupled the briefing with hands-on training scenarios to help controllers quickly become familiar with the generic sectors.

Twelve full performance level controllers participated in the study over a 6-week period. Each week, two controllers arrived for 3 days of simulation testing. We evaluated controller performance using objective measures produced by the laboratory simulation software and with subjective measures provided by the SMEs using an over-the-shoulder rating form. We assessed controller workload using the National Aeronautics and Space Administration Task Load Index and the Air Traffic Workload Input Technique. We measured ATCS situation awareness using self-ratings on a numeric scale. In addition, controllers completed questionnaires after each scenario and at the end of the study.

The results indicated that dynamic resectorization did not interfere with ATCS performance. Most of the objective and subjective measures of performance indicated that there was no difference between fixed and dynamic airspace boundaries in either of the traffic situations examined. However, the results indicated slightly fewer separation losses for dynamic resectorization in the heavy traffic scenarios, although this trend was not statistically reliable. There was no difference in the number of separation losses for the shifting weather scenarios.

The results also indicated fewer land line communications for dynamic resectorization in the weather scenarios. Dynamically allocating a predefined area of airspace between the sectors eliminated the need for most of the coordination communications. In contrast, the heavy traffic scenarios indicated slightly more land line communications for dynamic resectorization. In fixed boundary baseline scenarios, aircraft were simply handed-off between sectors and no land line communications were necessary.

Finally, the results indicated slightly lower NASA-TLX workload ratings in dynamic resectorization scenarios. However, dynamic resectorization did not reduce controller situation awareness.

Future studies are needed to explore different approaches to dynamic resectorization. The potential benefits of both horizontal and vertical dynamic resectorization need to be examined as well as resectorization between TRACONS and ARTCCs. The present study identified specific high-density traffic and weather situations that can benefit from dynamic resectorization. However, dynamic resectorization may not be effective for all traffic situations.

It is important to identify situations where dynamic resectorization may be beneficial and situations where resectorization should not be made. Other issues that need investigation are when airspace boundaries should be adjusted and what form they should take.

## 1. Introduction

Dynamic resectorization of airspace could enhance the efficient handling of heavy traffic, accommodate shifting weather conditions, status changes in special use airspace, as well as result in increased safety and in cost benefits to National Airspace System (NAS) users. However, depending upon how procedures are implemented, dynamic resectorization may be disruptive, increase controller workload, and cause other negative consequences. The human-in-the-loop simulation described in this report was designed to investigate a specific implementation of dynamic resectorization between two adjacent Air Route Traffic Control Centers (ARTCCs).

The Human Factors FY2000 Program Baseline Research Plan of Air Traffic Services assesses issues related to airspace boundary adjustments. The ARA Performance Plan Goal 1 (safety) calls for the Federal Aviation Administration (FAA) to utilize baseline data to identify human performance issues in air traffic management (ATM). This study directly addresses the ATS Subcommittee Report of the NAS ATM Research and Development Advisory Committee's mandate to focus research on the ability of Air Traffic Control Specialists (ATCSs) to deal with flexible airspace (e.g., dynamic resectorization).

Current airspace structure is rigid and does not allow for dynamic resectorization of airspace boundaries. Dynamic resectorization is adaptive and can efficiently handle heavy traffic situations, shifting weather conditions, status changes in special use airspace, and user-preferred routes. Dynamic resectorization has the potential to reduce aircraft delays, decrease fuel consumption, and lower operating costs for the airline industry. The potential benefits for ATCSs are to offset heavy workload and reduce coordination and communications. However, dynamic resectorization may be disruptive and could have negative consequences for controller situational awareness and performance. There are different approaches to implementing dynamic resectorization using current and future automation tools. Some methods may be less disruptive and more effective than others.

Inter-facility dynamic resectorization represents a radical change from current, mostly static procedures that determine airspace boundaries. If inter-facility dynamic resectorization is used to support increased flight flexibility, it still must provide controllers the cues, information, and organization necessary to maintain situation awareness and aircraft safety. The key is ensuring that the dynamic resectorization process itself does not impair system efficiency.

### 1.1 Background

Due to areas of severe weather, air turbulence, navigational, or communications equipment problems, it often becomes necessary to divert air traffic from their normal or preferred routes. Sometimes, sectors become so congested with traffic that aircraft must be diverted to avoid the sector. Allowing airspace users more flexibility in determining flight routes and the implementation of Free Flight proposals will further exacerbate these pressures over preferred routes or sectors (Planzer & Jenny, 1995; RTCA 1995a, 1995b). The increased flight flexibility associated with Free Flight could lead to situations in which current airspace sector configurations no longer match traffic flows. To accommodate Free Flight, the sectorization of airspace will also need to be more flexible, especially if controllers maintain responsibility for safe separation.

The forecast for increasing air traffic demands over the next decade (Honeywell, Inc, 1997; Wickens, Mavor, Parasuraman, & McGee, 1998) will promote higher traffic density in most sectors of the NAS. In order to avoid heavy sector congestion, the Traffic Management Unit (TMU) may implement initiatives such as the En Route Spacing Program (ESP), mile in-trail restrictions, or a ground delay. When these initiatives are set in motion, the result is a delay to the aircraft. Rather than implementing a ground delay or rerouting the aircraft and possibly causing heavy congestion in nearby sectors, adaptive airspace management techniques like dynamic resectorization are being proposed (Eurocontrol, 1998). Instead of rerouting the traffic to match the existing resources, dynamic resectorization could theoretically optimize Air Traffic Control (ATC) resources and lead to a more balanced system workload. Carlson and Rhodes (1998) described some adaptive airspace management practices currently in use in the operational environment. Some involve the lateral reconfiguration of sectors inside the same facility. In other instances, ARTCC and Department of Defense (DOD) facilities delegate some of their airspace to neighboring facilities.

All cases except one<sup>1</sup> involve the use of predefined airspace configurations. Using Salt Lake City En Route ARTCC airspace, researchers conducted a fast-time simulation to investigate this concept of dynamic resectorization. They adjusted sector boundaries in response to representative traffic flows from the actual airspace (Goldberg & Eberlin, 1997; Honeywell, Inc., 1997). Results indicated that adaptive sectors offered more user-preferred routing thus reducing delays and enhancing aircraft fuel efficiency.

In another related study, Pawlak, Bowles, Goel, and Brinton (1997) evaluated the impact of lateral resectorization on controller performance. They conducted a human-in-the-loop simulation in which pairs of controllers were responsible for two adjacent high-altitude sectors above Cleveland. The authors assigned each controller to one of the two sectors during the five 40-minute scenarios of the experiment. They designed the first scenario to represent a baseline condition in which the sector boundaries remained fixed. The order of presentation of the four other scenarios was randomly determined. They defined these four scenarios by a cross of two independent variables: sector dynamics and sector set. The sector dynamics varied in two ways. In the continuously changing condition, they adjusted the sector boundaries as often as necessary. In the interval condition, they optimized boundaries only at 15-minute intervals. There were also two types of sector set (limited and unlimited). During the limited set condition, only seven possible new sector configurations could be used. For the unlimited sector set condition, any boundary configuration was possible.

Results from this study indicated the following recommendations for future research:

- a. Procedures for changing sector boundaries must be formalized to ensure that transitions proceed smoothly.
- b. Automated enhancements can be used to minimize the amount of controller to controller coordination needed to accommodate a sector change.

---

<sup>1</sup>The Jacksonville Naval Air Station's Fleet Area Control and Surveillance Facility (FACSFACJAX) has the capability to dynamically modify the lateral boundaries of restricted zones, for example, areas designated as off limits due to the presence of protected species of whales.

- c. The frequency with which sector boundaries can change will be constrained by the complexity of the traffic situation and the complexity associated with making each boundary change.
- d. Unless significant ATM system changes are made, current radio frequency limitations and controller specialization in certain areas of airspace will probably restrict the magnitude of boundary changes.
- e. New sector configurations may need to be limited to a pre-defined set so those controllers can receive appropriate training for each configuration.
- f. Added flexibility to accommodate weather systems or unusual traffic patterns may also be beneficial.

In an airspace with high traffic density, there is higher probability for conflicts and increased controller workload. Airspace sectors that can be restructured to make use of the complete resources of the ATCSs have the potential to increase overall system safety, provide a more balanced workload for the controller, and reduce costly delays.

## 1.2 Purpose

The purpose of this study was to conduct a human factors evaluation of the potential impact of dynamic resectorization between adjacent ARTCCs on controllers using a real-time ATC simulation. This study compared operations between a standard en route airspace with fixed boundaries to an en route airspace with dynamic boundaries. This should be viewed as an initial investigation of the dynamic resectorization concept and not as a comprehensive assessment.

## 1.3 Study Objective and Limitations

We examined the impact of inter-facility dynamic resectorization on controller workload, communication, situational awareness, control strategies, and performance. Because there are current practices such as airspace shelving for altering vertical sector boundaries, we limited the investigation to lateral sector adjustments.

## 2. Method

Two Human Factors Specialists from the NAS Human Factors Branch (ACT-530) and two ATCS Subject Matter Experts (SMEs) conducted the simulation in the Research Development and Human Factors Laboratory (RDHFL) at the FAA William J. Hughes Technical Center. . A team of trained simulation pilots operated aircraft using simple keyboard commands and communicated with the controllers using ATC phraseology. Support engineers from ACT-510 ensured that the simulation system functioned accurately and recorded the required performance data properly.

### 2.1 Participants

Current, non-supervisory, full performance level ATCSs participated in this simulation study. We requested 12 ATCSs from at least six different ARTCCs. Participants were required to have self-reported corrected vision of at least 20/30. They ranged from 31 to 56 years of age (M=44.3) with an average of 15.4 years of ARTCC experience. Participants filled out an

Informed Consent form explaining that their participation in this study was strictly voluntary and that their privacy was protected (Appendix A). We maintained strict adherence to all Federal, Union, and ethical guidelines throughout the study. Participants were allowed to withdraw from the study at any time without penalty. The simulation evaluated the concept of inter-facility dynamic resectorization and not individual controllers.

## 2.2 Equipment

The simulation equipment consisted of workstations with large high-resolution displays, a voice communications system, networked computer resources, and ATCoach (1996) simulation software.

As part of the simulation materials, we printed and time ordered flight progress strips in a strip bay prior to the start of each scenario. We audio-video recorded the simulation and included a touchscreen for the Air Traffic Workload Input Technique (ATWIT) (Stein, 1985) in the system.

## 2.3 Airspace

The research team selected the en route environment and a generic ARTCC airspace (Genera Center). A generic airspace has several advantages relative to modeling an actual airspace in simulations. Using a generic airspace, researchers can select a cross-section of controllers from different Air Traffic facilities and quickly train them to operate within the airspace. We developed Genera Center (ZGN) using the ATCoach (1996) simulation model that closely replicates the en route environment. ZGN has the flexibility to interface with the Generic Terminal Radar Control (TRACON), a generic airspace environment that was validated in a previous simulation (Guttman, Stein, & Gromelski, 1995). ZGN consists of easily remembered fix names and simplified operating procedures. We divided ZGN into two separate center configurations to simulate an inter-facility operation. We gave an airspace briefing to each participant, which described ZGN and pertinent standard operating procedures (SOPs), sector layouts, and jet routes. In this briefing, we also described the areas of responsibility during dynamic resectorization. This is important because controllers would have to be certified on these portions of adjacent center airspace in order for an adjustment to be permitted.

## 2.4 Traffic Scenarios

Controllers conducted traffic in two different experimental conditions. In the first condition, they employed dynamic resectorization between the two ARTCC configurations. The second condition involved current operating procedures for controlling and directing traffic between ARTCC facilities and served as a baseline for comparison. There were four scenarios for each condition. Two of the scenarios consisted of rather heavy traffic, and two were a combination of medium traffic and a severe weather system. Each scenario was 60 minutes in duration and consisted of a mix of jet aircraft operating in instrument flight rules conditions. All scenarios started without any initial aircraft on the radar display. Then, aircraft steadily appeared, creating a buildup. This level of traffic was maintained for the duration. Each controller experienced all scenarios from each position (four from one ARTCC the first day and four from the other ARTCC the following day). In all scenarios, controllers directed traffic according to current

ATC procedures (with the exception of procedural changes associated with inter-facility dynamic resectorization).

## 2.5 Design

To evaluate situations that might have an impact on the controller operating in a dynamic airspace, we decided to limit our investigation to two independent variables: Airspace Type and Traffic Situation. The experimental design can be summarized as a 2 X 2 within-subjects (or repeated measures) design with the factors of Airspace Type (fixed or dynamic) and Traffic Situation (high density or weather). We administered eight scenarios in a randomized order (Appendix B). We designed the scenarios so that the North Center (ZNO) always had the problem (high density traffic or severe weather). The South Center (ZSO) acquired an area from ZNO through resectorization. We intended the resectorization to be a solution to the traffic situation in ZNO without significantly impacting operations in ZSO.

### 2.5.1 Independent Variables

We examined these variables in terms of two conditions over eight scenarios:

#### a. High-Density Traffic Scenarios

1. Baseline Fixed Boundaries with High-Density Traffic – This condition employed current 7110.65M ATC procedures for controlling traffic. It consisted of a large volume of aircraft, some of which were transferring from ZSO to ZNO. Each controller performed this baseline scenario from ZNO and ZSO (see Figure 1a).
2. Dynamic Resectorization with High-Density Traffic – This condition included the same traffic flow as in the Baseline High-Density scenario. It started with a baseline airspace configuration. At 17 minutes into the scenario, the airspace was resectorized as shown in Figure 1b to distribute the taskload more evenly between controllers and accommodate the large volume of aircraft. Participants experienced this scenario once from ZNO and once from ZSO.

#### b. Weather Scenarios

1. Baseline Fixed Boundaries with Weather – This condition also employed current 7110.65M ATC procedures for controlling traffic. This scenario consisted of a moderate volume of aircraft that is accompanied by severe weather. Each controller performed this baseline scenario from ZNO and ZSO (see Figure 2a).
2. Dynamic Resectorization with Weather – This condition included the same traffic flow as in the Baseline Weather scenario. The scenario started with a baseline airspace configuration. At 17 minutes into the scenario, the airspace was resectorized as shown in Figure 2b to allow one controller to have more airspace available to maneuver aircraft around the weather. Participants experienced this scenario once from ZNO and once from ZSO.

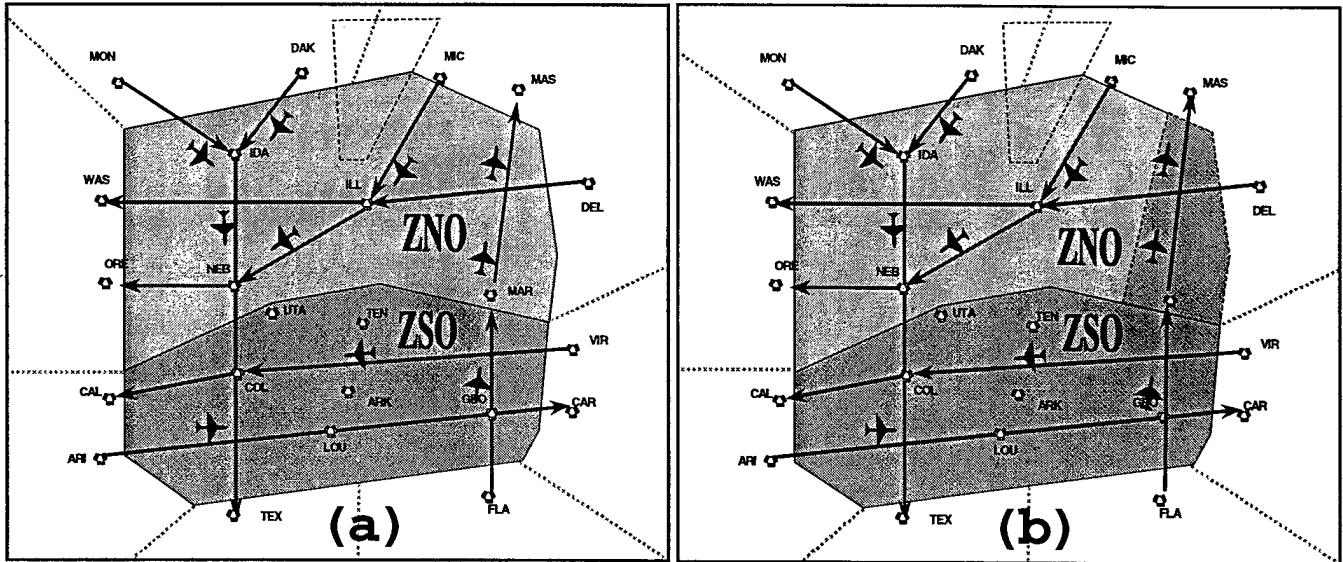

Figure 1. High-Density Traffic Scenarios. (a) Airspace boundaries for baseline scenario. (b) Airspace boundaries for resectorization scenario after resectorization has been completed. The resectorized portion of airspace in this scenario was referred to as the “northeast corridor.”

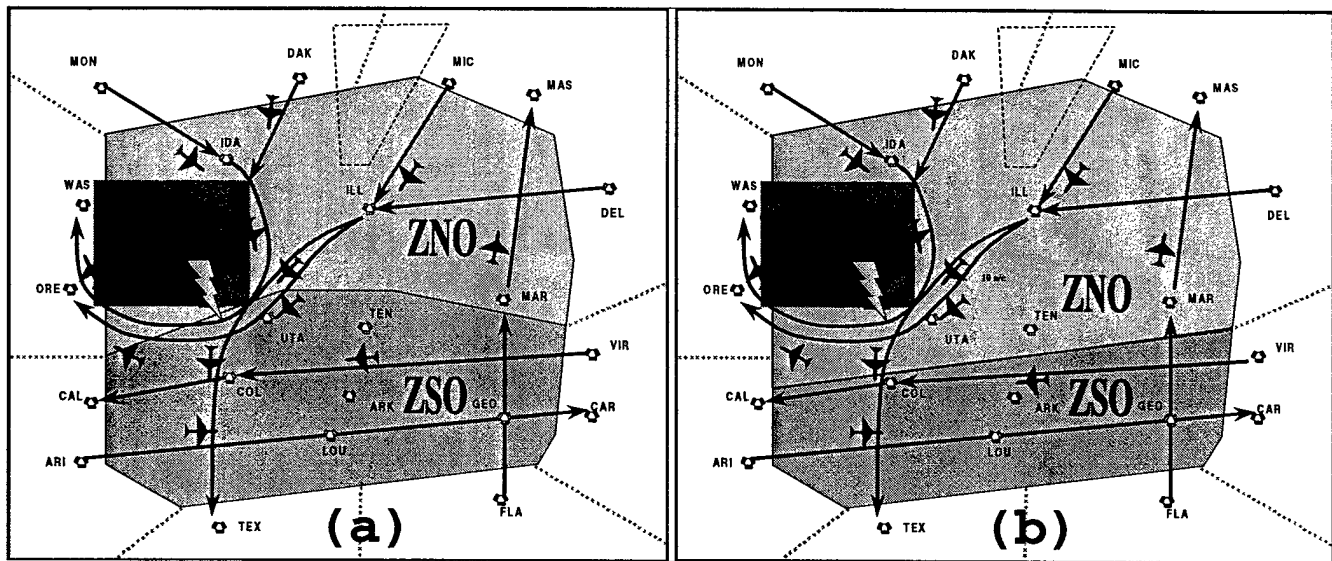

Figure 2. Weather Scenarios. (a) Airspace boundaries for baseline scenario. (b) Airspace boundaries for resectorization scenario after resectorization has been completed. The resectorized portion of airspace in this scenario was referred to as “thunder alley.”

### 2.5.2 Dependent Variables

The automated data collection system of the RDHFL produces a large set of objective system effectiveness measures that are typically examined in ATC simulation research (Buckley,

DeBaryshe, Hitchner, & Kohn, 1983). Table 1 lists selected measures separated into three categories: safety, capacity, and efficiency.

Table 1. System Effectiveness Measures

---

<b>1 – SAFETY</b>
NECNF – Number of Standard En Route Conflicts
<b>2 – CAPACITY</b>
NCOMP – Number of Flights Completed
<b>3 – EFFICIENCY</b>
NPTT – Number of Controller Push-to-Talk Communications
DPTT – Cumulative Duration of Controller Push-to-Talk Communications
NALT – Frequency of Altitude Changes
NHDG – Frequency of Heading Changes
NSPD – Frequency of Airspeed Changes
NLL – Frequency of Land Line Communications
DLL – Cumulative Duration of Land Line Communications
DIST – Distance Flown for All Flights

---

Additionally, two SMEs observed controllers for over-the-shoulder (OTS) ratings of performance. The SMEs used an observation form (Appendix C) specifically designed for use in ATC human factors research (Sollenberger, Stein, & Gromelski, 1997; Vardaman & Stein, 1998). Table 2 shows the 26 different rating scales of the observation form organized into six major performance categories. We sampled controller workload in real time during each scenario using the ATWIT, a subjective rating method (Stein, 1985) and, upon completion of each scenario, using the NASA Task Load Index (TLX) subjective mental workload scale (Hart & Staveland, 1988).

## 2.6 Procedures

The participants arrived at the RDHFL in pairs for a week of simulation testing. Each pair followed a schedule as shown in Table 3. Monday and Friday were scheduled for travel. Tuesday, Wednesday, and Thursday consisted of project briefing, sector training, and simulation test scenarios. Participants worked from 8:00 AM to 4:30 PM with a lunch period and a couple of breaks each day. They filled out a Background Questionnaire (Appendix D), and the research team assigned a participant code. To assure anonymity, only the participant and the research team knew this number. All questionnaires and performance data collected referenced the participant code and not individual controller names.

After each scenario, participants completed a Post-Scenario Questionnaire, the NASA TLX, and an Exit Questionnaire (Appendix D) on the last day of the study during the final debriefing.

Table 2. Observation Rating Form (En Route Environment)

- 
- I – MAINTAINING SAFE AND EFFICIENT TRAFFIC FLOW**
1. Maintaining Separation and Resolving Potential Conflicts
  2. Sequencing Arrival, Departure, and En Route Aircraft Efficiently
  3. Using Control Instructions Effectively/Efficiently
  4. Overall Safe and Efficient Traffic Flow Scale Rating
- II – MAINTAINING ATTENTION AND SITUATIONAL AWARENESS**
5. Maintaining Situational Awareness
  6. Ensuring Positive Control
  7. Detecting Pilot Deviations from Control Instructions
  8. Correcting Errors in a Timely Manner
  9. Overall Attention and Situational Awareness Scale Rating
- III – PRIORITIZING**
10. Taking Actions in an Appropriate Order of Importance
  11. Preplanning Control Actions
  12. Handling Control Tasks for Several Aircraft
  13. Marking Flight Strips while Performing Other Tasks
  14. Overall Prioritizing Scale Rating
- IV – PROVIDING CONTROL INFORMATION**
15. Providing Essential Air Traffic Control Information
  16. Providing Additional Air Traffic Control Information
  17. Providing Coordination
  18. Overall Providing Control Information Scale Rating
- V – TECHNICAL KNOWLEDGE**
19. Showing Knowledge of LOAs and SOPs
  - 20a. Showing Knowledge of Aircraft Capabilities and Limitations
  - 20b. Showing Effective Use of Equipment
  21. Overall Technical Knowledge Scale Rating
- VI – COMMUNICATING**
22. Using Proper Phraseology
  23. Communicating Clearly and Efficiently
  24. Listening to Pilot Readbacks and Requests
  25. Overall Communicating Rating Scale
- 

Table 3. Participant Schedule

Tuesday		Wednesday		Thursday	
Time	Activity	Time	Activity	Time	Activity
8:00 - 9:15	Project Briefing	8:00 - 9:15	Test Scenario 1	8:00 - 9:15	Test Scenario 5
9:15 - 9:45	Break	9:15 - 9:45	Break	9:15 - 9:45	Break
9:45 - 11:00	Practice Scenario 1	9:45 - 11:00	Test Scenario 2	9:45 - 11:00	Test Scenario 6
11:00 - 12:30	Lunch	11:00 - 12:30	Lunch	11:00 - 12:30	Lunch
12:30 - 1:45	Practice Scenario 2	12:30 - 1:45	Test Scenario 3	12:30 - 1:45	Test Scenario 7
1:45 - 2:15	Break	1:45 - 2:15	Break	1:45 - 2:15	Break
2:15 - 3:30	Debriefing	2:15 - 3:30	Test Scenario 4	2:15 - 3:30	Test Scenario 8
				3:30 - 4:00	Break
				4:00 - 4:30	Final Debriefing

**Note.**

Practice scenarios were 60 minutes in duration with moderate traffic.

Participants worked 2 practice scenarios (one from ZNO, the other from ZSO)

Test scenarios were 60 minutes in duration.

Participants worked 4 with high density traffic (2 baseline and 2 resectorization) and 4 with severe weather (2 baseline and 2 resectorization)

Post-Scenario Questionnaires were part of 30-minute break period

The SMEs performed the on-the-job-training subjective rating during each trial. They also interacted with the participant in the beginning and ending of each trial and in communicating with the simulation pilots, as needed. A voice communication link to another room allowed controllers to issue commands to the simulation pilots.

We used the ATWIT (Stein, 1985) to assess controller workload during the scenario. The ATWIT provides an unobtrusive and reliable means for collecting self-report ratings of controller workload as they control traffic. A touchscreen was used to present a workload rating scale and record the participant responses. The controllers indicated their current workload by pressing one of the touchscreen buttons labeled from 1 (low) to 10 (high). The touchscreen was programmed to request controller input every 5 minutes by emitting several beeps and presenting the rating scale. Participants had 20 seconds to respond. If they did not respond within that 20 seconds, the maximum workload rating of 10 was recorded.

### 2.7 Training

We developed a training program to help controllers learn ZGN and become familiar with the simulation setup and procedures. A member of the research team described the SOPs of ZGN and the resectorization process to controllers (Appendix E). They then demonstrated the SOPs and resectorization as part of the first practice scenario. In the remaining time scheduled for training, participants had the opportunity to work an additional practice scenario in an airspace with reconfigurable sector boundaries.

### 3. Results

We used Analysis of Variance (ANOVA) to determine the effects of resectorization on the dependent measures collected in the simulation. ANOVA is a statistical procedure for determining whether the differences between means are due to the manipulated (or independent) variables or due to chance alone. The results of the analysis produce an  $F$  statistic and an associated  $p$  value. The  $p$  value is the probability that the differences in the means are due to chance alone. Researchers compare the  $p$  value to a selected significance level to determine if the differences are statistically significant. By convention, a  $p$  value that is greater than .05 is not considered statistically significant.

Researchers refer to the analysis associated with each independent variable as a main effect and the analysis associated with the combinations of variables as the interaction effect. An interaction occurs when the effects of one variable are different depending upon the level of another variable. If an interaction is significant, the experiment must be broken down into its basic components, referred to as simple main effects. One simple main effect is the difference between Airspace Type (fixed or dynamic) and the other is Traffic Situation (high density or weather).  $F$  statistics are then computed for each simple main effect.

Significant main effects or simple main effects with more than two levels require a post hoc comparison procedure in order to determine which levels are statistically significant. In the present study, significant main effects for Traffic Situation are not very meaningful because the weather and high-density scenarios were considerably different from each another. Rather, we

were interested in main effects for Airspace Type and the interactions between Airspace Type and Traffic Situation.

We conducted a two-way repeated measures ANOVA, which was collapsed across both the North and South ARTCCs for the majority of the dependent measures. Tables summarize the results of the analyses and report the  $F$  statistics associated with the effects for each dependent measure. Graphs present the means of the experimental conditions in more detail for selected dependent measures.

### 3.1 System Effectiveness Measures

Twelve separation losses<sup>2</sup> occurred during the 96 experimental runs. Figure 3 presents the means of these separation losses across experimental conditions. There were no differences in separation losses in the weather scenarios as a function of resectorization. However, in the high-density traffic scenario, participants had fewer separation losses when dynamic resectorization was employed. Although this difference was not significant at the .05 level, there was a trend toward significance [ $F(1,11) = 4.66, p = .0538$ ].

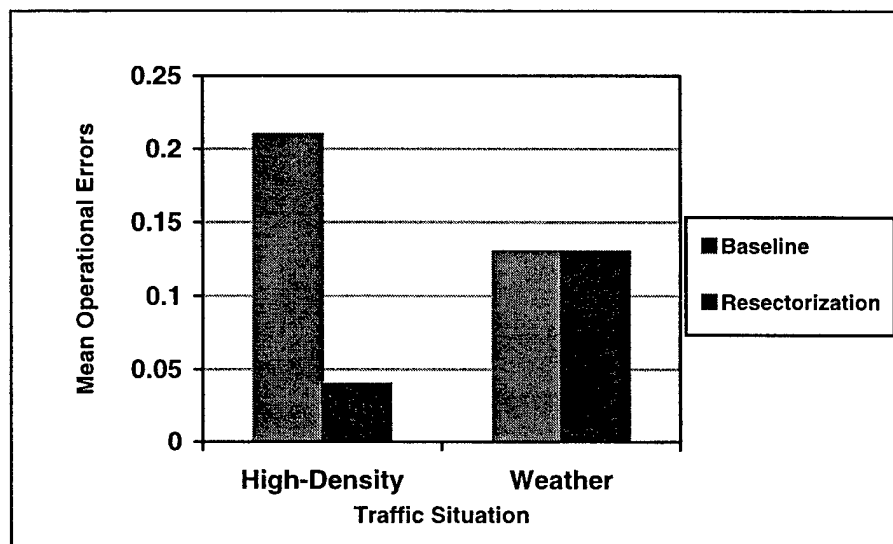

Figure 3. Separation losses across conditions.

Table 4 shows the results of the two-way ANOVA for the system effectiveness measures. There were several interactions between Airspace Type and Traffic Situation for these measures. The simple main effects revealed significant decreases in the number of flights completed and the number of flights handled in the resectorization condition. Table 5 shows the results of the analysis of simple main effects. As expected, there were significant differences in the high-density scenario for flights completed and flights handled as a function of Airspace Type.

<sup>2</sup>A loss of separation occurs when aircraft do not have either 5 nm lateral separation or 2,000 ft vertical separation when above 29,000 ft or 1,000 ft vertical separation when below 29,000 ft.

Table 4. *F* Statistics Obtained From the Two-Way ANOVA Performed on the System Effectiveness Measures

Measure	Main Effect: Airspace	Main Effect: Traffic	Interaction Effect
NECNF – standard conflicts	$F(1,11) = 4.66†$	$F(1, 11) = 0.13$	$F(1,11) = 0.80$
NCOMP – flights completed	$F(1,11) = 84.57*$	$F(1, 11) = 59.60*$	$F(1,11) = 79.26*$
NPTT – number of transmissions	$F(1, 11) = 4.37$	$F(1, 11) = 5.76*$	$F(1, 11) = 3.41$
DPTT – duration of transmissions	$F(1, 11) = 0.09$	$F(1, 11) = 1.09$	$F(1, 11) = 8.25*$
NALT – altitude changes	$F(1, 11) = 0.13$	$F(1, 11) = 12.23**$	$F(1, 11) = 0.13$
NHDG – heading changes	$F(1, 11) = 0.12$	$F(1, 11) = 11.34**$	$F(1, 11) = 0.23$
NSPD – speed changes	$F(1, 11) = 0.08$	$F(1, 11) = 2.42$	$F(1, 11) = 0.35$
NLL – number of land line comms.	$F(1, 11) = 35.57*$	$F(1, 11) = 167.28*$	$F(1, 11) = 196.95*$
DLL – duration of land line comms.	$F(1, 11) = 2.56$	$F(1, 11) = 64.30*$	$F(1, 11) = 14.11*$
DIST – distance of flights	$F(1, 11) = 0.19$	$F(1, 11) = 24.98*$	$F(1, 11) = 0.59$

\* indicates a statistically reliable effect at a significance level of  $p < .05$

\*\* indicates a statistically reliable effect at a significance level of  $p < .01$

† indicates an effect that was not statistically significant but nearly significant with a  $p < .06$

Table 5. Mean Completed Flights and *F* Statistics Obtained from the Analysis of Simple Main Effects

High Density			Weather		
Baseline	Dynamic	<i>F</i> Statistics	Baseline	Dynamic	<i>F</i> Statistics
48.87	43.50	176.86**	43.33	43.54	0.23

\* indicates a statistically reliable effect at a significance level of  $p < .05$

\*\* indicates a statistically reliable effect at a significance level of  $p < .01$

The efficiency indicators showed several interactions between Airspace Type and Traffic Situation. There were no significant differences found for NPTT as a function of Airspace Type, however, there was a significant interaction obtained for the duration of those communications. Figure 4 represents the Airspace Type by Traffic Situation interaction of the mean total duration of push-to-talk transmissions (DPTT). Table 6 shows the results of the analysis of simple main effects. In the high-density scenario, the duration of controller transmissions was not as brief in the baseline condition as compared to when they resectorized. Under the weather scenario, it appears to turn in the opposite direction. However, this difference was not significant.

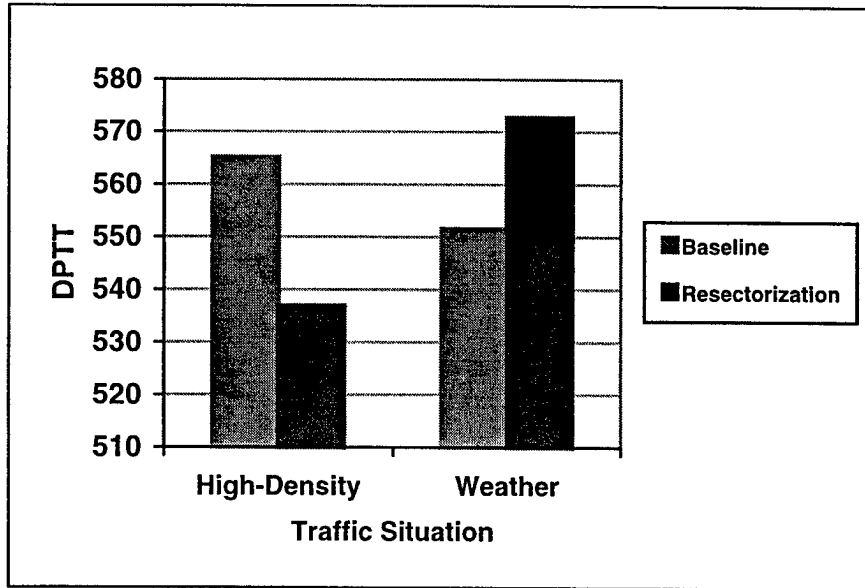

Figure 4 Airspace type by traffic situation interaction for duration of push-to-talk transmissions.

Table 6. Mean DPTT and *F* Statistics Obtained from the Analysis of Simple Main Effects

High Density			Weather		
Baseline	Dynamic	<i>F</i> Statistics	Baseline	Dynamic	<i>F</i> Statistics
565.04	536.88	8.57*	551.42	572.63	1.41

\* indicates a statistically reliable effect at a significance level of  $p < .05$   
 \*\* indicates a statistically reliable effect at a significance level of  $p < .01$

Two other efficiency indicators, frequency (NLL) and duration of land line (DLL) communications, showed significant interactions. Figure 5 and Figure 6 illustrate these relationships.

Controllers utilized the land line for coordination of traffic between the ZNO and ZSO. Analysis of simple main effects for these interactions revealed that for the high-density traffic situation, dynamic resectorization required more land-line communications than the baseline. For the weather situation, the reverse was true. The baseline scenario required considerably more coordination than the dynamic resectorization scenario. The duration of ground to air communications under resectorization went up during the weather scenario, but land-line coordination calls were significantly reduced. Table 7 and Table 8 show the results of the analysis of simple main effects.

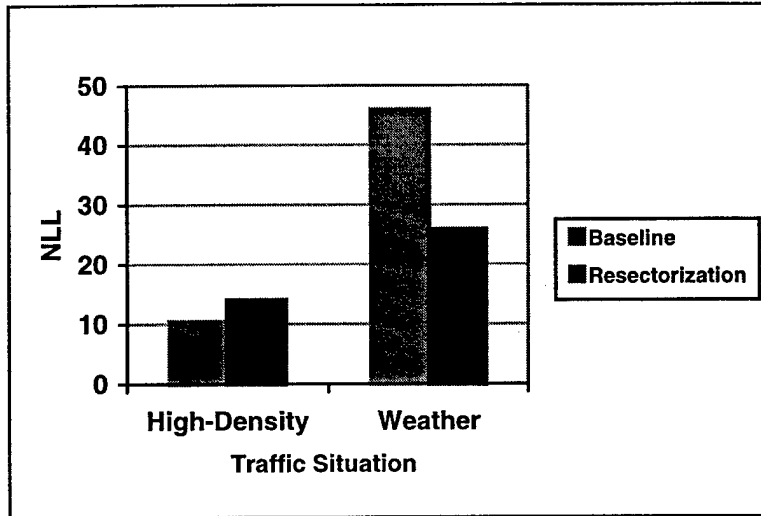

Figure 5. Airspace type by traffic situation interaction for number of land line communications.

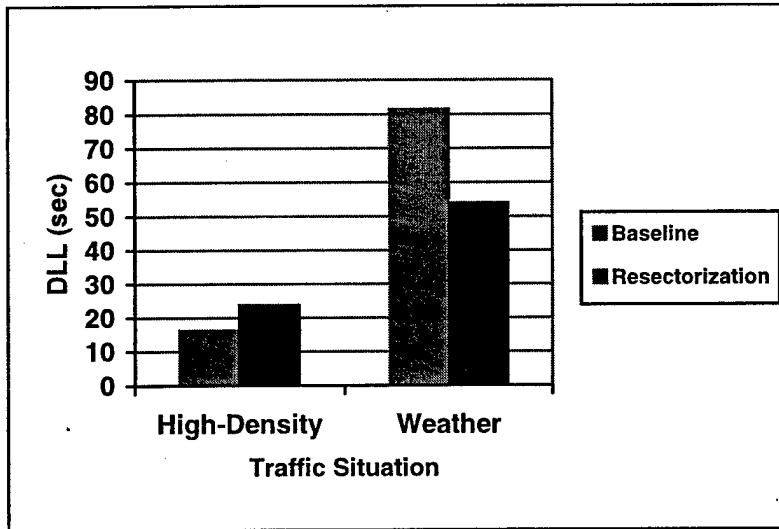

Figure 6. Airspace type by traffic situation interaction for duration of land line communications.

Table 7. Mean NLL and *F* Statistics Obtained from the Analysis of Simple Main Effects

High Density			Weather		
Baseline	Dynamic	<i>F</i> Statistics	Baseline	Dynamic	<i>F</i> Statistics
10.33	13.96	15.01**	45.88	25.79	92.53**

\* indicates a statistically reliable effect at a significance level of  $p < .05$   
 \*\* indicates a statistically reliable effect at a significance level of  $p < .01$

Table 8. Mean DLL and *F* Statistics Obtained from the Analysis of Simple Main Effects

High Density			Weather		
Baseline	Dynamic	<i>F</i> Statistics	Baseline	Dynamic	<i>F</i> Statistics
16.25	23.83	5.99*	81.54	54.08	6.79*

\* indicates a statistically reliable effect at a significance level of  $p < .05$   
 \*\* indicates a statistically reliable effect at a significance level of  $p < .01$

### 3.2 SME Ratings

Table 9 shows the results of the two-way ANOVA for the observer ratings. The *F* statistics indicate that Airspace Type had a strong effect on almost half of the observer ratings. For these significant differences, ratings were lower in the baseline scenarios. There was a significant interaction between Airspace Type and Traffic Situation for preplanning control actions. A simple main effects analysis of this relationship revealed that observers rated participants significantly higher in the high-density traffic situation when dynamic resectorization was implemented. Table 10 shows the results of the analysis of simple main effects. Figure 7 illustrates this interaction.

### 3.3 Controller Ratings

#### 3.3.1 NASA Task Load Index

We computed an unweighted total subjective workload score with a range of zero to 120 for each participant by summing the responses on the six subscales of the NASA-TLX. A two-way ANOVA performed on these scores revealed a significant main effect for Airspace Type [ $F(1,11) = 38.77$ ]. Participants rated both scenarios as more workload intensive when they were controlling traffic in the baseline airspace configuration. This suggests that they perceived a positive impact as a function of resectorization on their workload when they thought about it after the runs. However, there was no significant interaction between Airspace Type and Traffic Situation for these workload scores. We present the mean TLX scores in Figure 8.

Table 9. *F* Statistics Obtained From the Two-Way ANOVA Performed on the Observer Ratings

Rating	Main Effect: Airspace	Main Effect: Traffic	Interaction Effect
1. Maintaining separation	$F(1, 11) = 0.82$	$F(1, 11) = 0.27$	$F(1, 11) = 3.80$
2. Sequencing traffic	$F(1, 11) = 4.94^*$	$F(1, 11) = 5.43^*$	$F(1, 11) = 2.27$
3. Using control instructions	$F(1, 11) = 2.47$	$F(1, 11) = 6.32^*$	$F(1, 11) = 0.14$
4. Overall traffic flow	$F(1, 11) = 3.46$	$F(1, 11) = 3.02$	$F(1, 11) = 1.21$
5. Maintaining awareness	$F(1, 11) = 4.14$	$F(1, 11) = 2.78$	$F(1, 11) = 0.33$
6. Ensuring positive control	$F(1, 11) = 11.99^{**}$	$F(1, 11) = 1.18$	$F(1, 11) = 0.07$
7. Detecting pilot deviations	$F(1, 11) = 12.00^{**}$	$F(1, 11) = 6.26^*$	$F(1, 11) = 1.68$
8. Correcting own errors	$F(1, 11) = 5.18^*$	$F(1, 11) = 1.73$	$F(1, 11) = 0.00$
9. Overall attention & awareness	$F(1, 11) = 8.19^*$	$F(1, 11) = 4.87^*$	$F(1, 11) = 0.12$
10. Taking action in order	$F(1, 11) = 2.32$	$F(1, 11) = 0.03$	$F(1, 11) = 0.17$
11. Preplanning control actions	$F(1, 11) = 3.67$	$F(1, 11) = 4.12$	$F(1, 11) = 7.71^*$
12. Handling control tasks	$F(1, 11) = 8.37^*$	$F(1, 11) = 0.30$	$F(1, 11) = 0.19$
13. Marking flight strips	$F(1, 11) = 5.83^*$	$F(1, 11) = 25.91^{**}$	$F(1, 11) = 0.56$
14. Overall prioritizing	$F(1, 11) = 10.53^{**}$	$F(1, 11) = 10.91^{**}$	$F(1, 11) = 0.03$
15. Providing essential info	$F(1, 11) = 6.40^*$	$F(1, 11) = 0.85$	$F(1, 11) = 0.02$
16. Providing additional info	$F(1, 11) = 6.37^*$	$F(1, 11) = 5.58^*$	$F(1, 11) = 0.51$
17. Providing coordination	$F(1, 11) = 3.28$	$F(1, 11) = 1.91$	$F(1, 11) = 0.01$
18. Overall providing info	$F(1, 11) = 5.31^*$	$F(1, 11) = 3.63$	$F(1, 11) = 0.00$
19. Knowing LOAs and SOPs	$F(1, 11) = 2.43$	$F(1, 11) = 0.09$	$F(1, 11) = 0.00$
20a. Knowing aircraft capabilities	$F(1, 11) = 0.56$	$F(1, 11) = 2.05$	$F(1, 11) = 0.01$
20b. Effective use of equipment	$F(1, 11) = 14.57^{**}$	$F(1, 11) = 0.74$	$F(1, 11) = 0.93$
21. Overall technical knowledge	$F(1, 11) = 11.56^{**}$	$F(1, 11) = 1.67$	$F(1, 11) = 0.05$
22. Using proper phraseology	$F(1, 11) = 0.63$	$F(1, 11) = 2.16$	$F(1, 11) = 0.70$
23. Communicating clearly	$F(1, 11) = 0.31$	$F(1, 11) = 0.01$	$F(1, 11) = 2.19$
24. Listening to pilots	$F(1, 11) = 0.04$	$F(1, 11) = 0.08$	$F(1, 11) = 0.75$
25. Overall communicating	$F(1, 11) = 0.01$	$F(1, 11) = 0.20$	$F(1, 11) = 0.50$

\* indicates a statistically reliable effect at a significance level of  $p < .05$

\*\* indicates a statistically reliable effect at a significance level of  $p < .01$

Table 10. Mean OTS SME Ratings of Preplanning Control Actions and *F* Statistics Obtained from the Analysis of Simple Main Effects

High Density			Weather		
Baseline	Dynamic	<i>F</i> Statistics	Baseline	Dynamic	<i>F</i> Statistics
5.46	6.25	14.44**	5.42	5.25	0.40

\* indicates a statistically reliable effect at a significance level of  $p < .05$

\*\* indicates a statistically reliable effect at a significance level of  $p < .01$

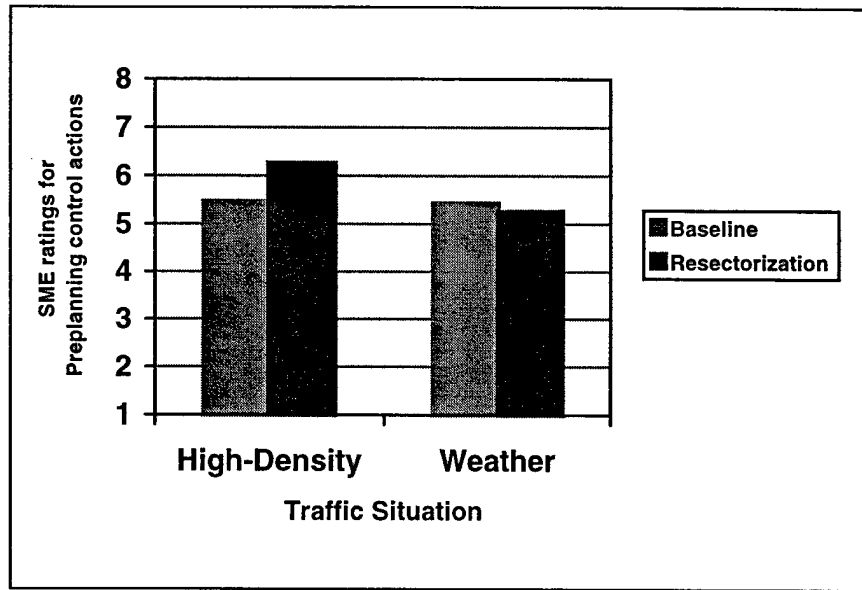

Figure 7. Airspace type by traffic situation interaction for preplanning control actions.

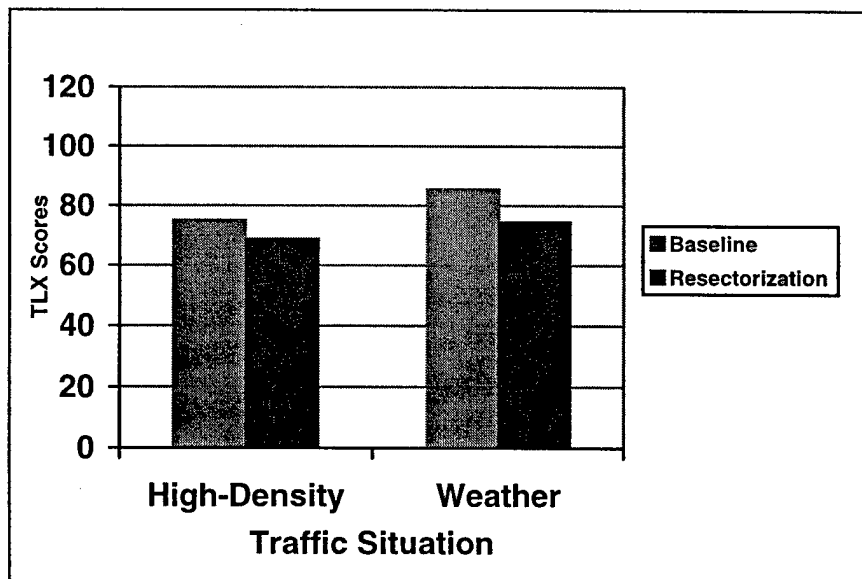

Figure 8. Mean NASA TLX scores.

### 3.3.2 ATWIT

In contrast to the TLX, ATWIT reflects workload estimates in real time. Table 11 shows the results of the two-way ANOVA for both the TLX scores and the ATWIT ratings. Figure 9 illustrates the ATWIT ratings as a function of Airspace Type and Traffic Situation. A two-way ANOVA revealed a significant interaction between these variables. Table 12 shows the results of the analysis of simple main effects. The *F* statistics indicate a significant decrease in controller workload for the weather scenario when dynamic resectorization was employed.

Table 11. *F* Statistics Obtained From the Two-Way ANOVA Performed on NASA TLX and ATWIT Workload Ratings

Measure	Main Effect: Airspace	Main Effect: Traffic	Interaction Effect
NASA TLX	$F(1, 11) = 38.77^{**}$	$F(1, 11) = 39.04^{**}$	$F(1, 11) = 1.76$
ATWIT	$F(1, 11) = 5.54^*$	$F(1, 11) = 15.81^{**}$	$F(1, 11) = 5.51^*$

\* indicates a statistically reliable effect at a significance level of  $p < .05$   
 \*\* indicates a statistically reliable effect at a significance level of  $p < .01$

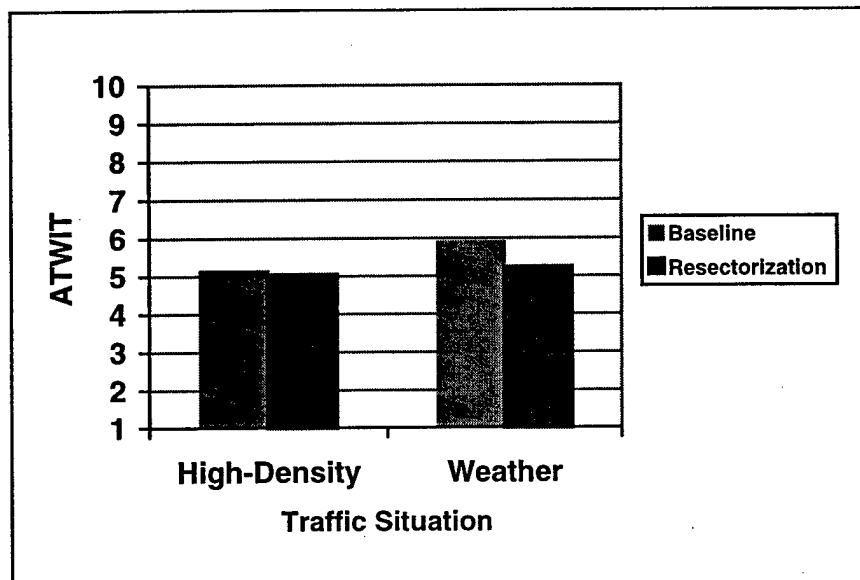

Figure 9. Airspace type by traffic situation interaction for atwit ratings.

Table 12. Mean ATWIT Ratings, *F* Statistics Obtained from the Analysis of Simple Main Effects

High Density			Weather		
Baseline	Dynamic	<i>F</i> Statistics	Baseline	Dynamic	<i>F</i> Statistics
5.14	5.03	.33	5.90	5.22	9.89**

\* indicates a statistically reliable effect at a significance level of  $p < .05$   
 \*\* indicates a statistically reliable effect at a significance level of  $p < .01$

For the high-density traffic situation when dynamic resectorization occurred, there was a slight, though non-significant, decrease in controller workload. In real time, differences still existed, but they were not quite as clear. To better understand these differences, the mean ratings were broken down over time by scenario and Airspace Type and are depicted in Figures 10 and 11.

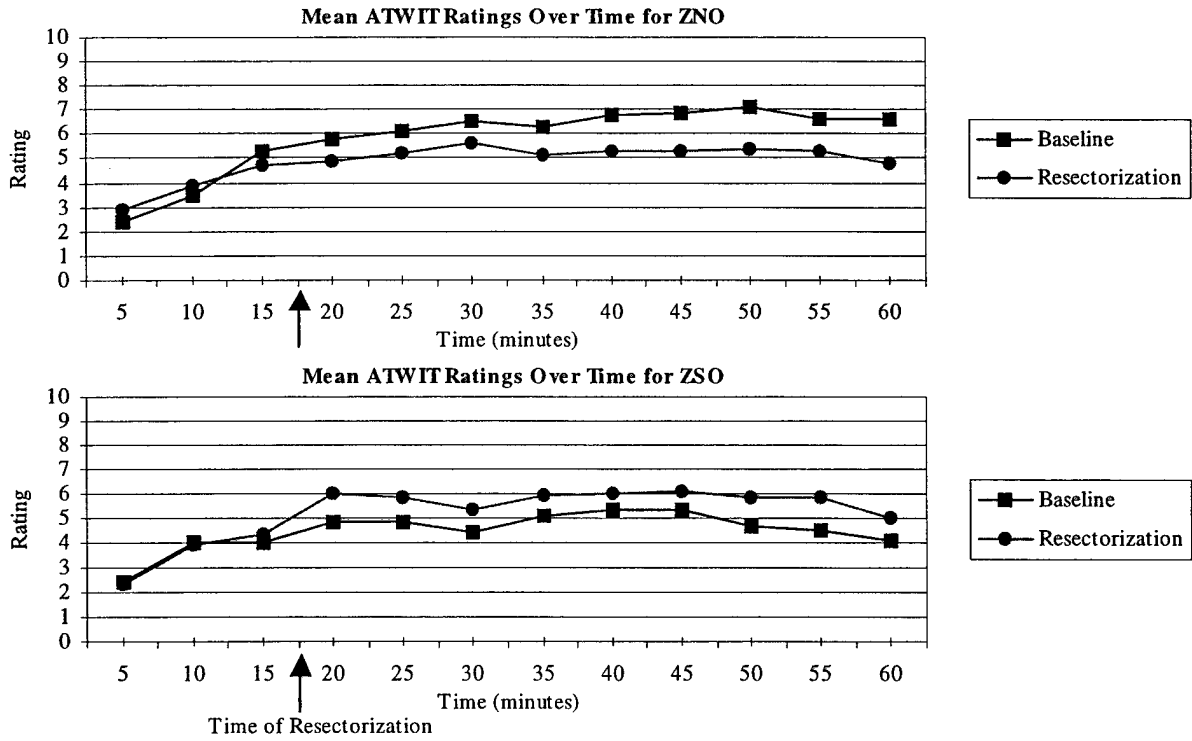

Figure 10. ATWIT interval data for the high density traffic scenario.

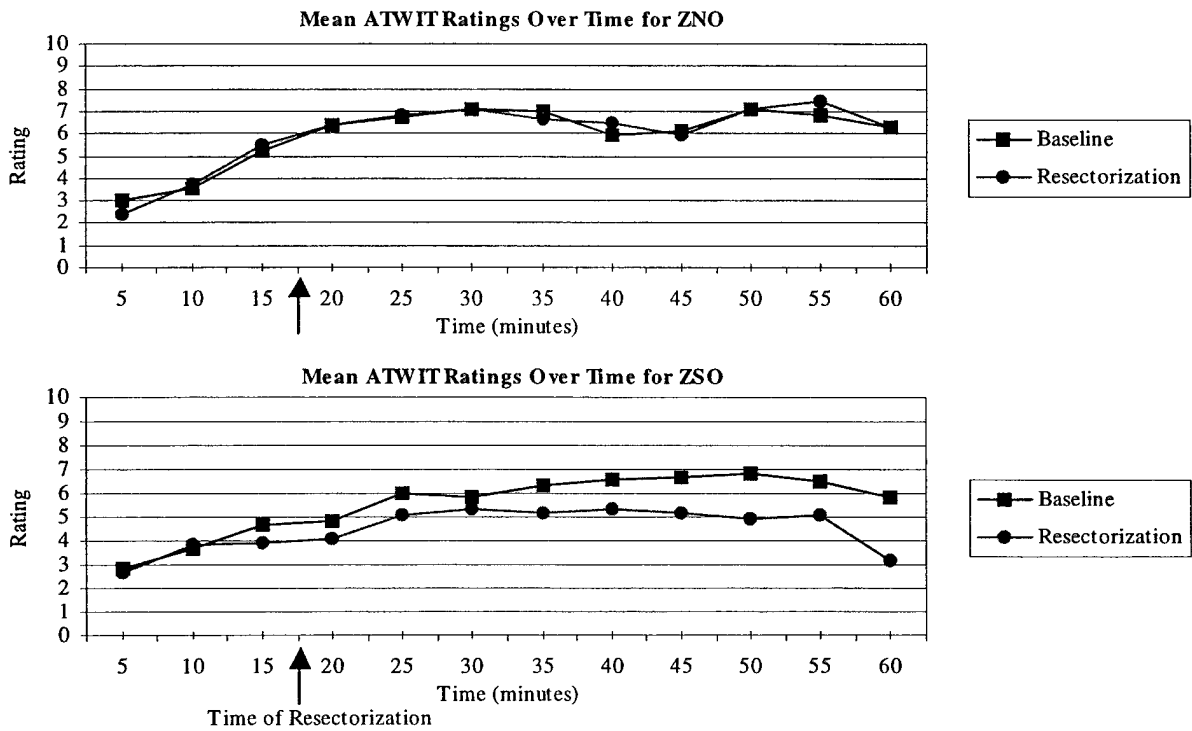

Figure 11. ATWIT interval data for the weather scenario.

### 3.3.3 Post-Scenario Questionnaire Ratings

Table 13 shows the results of the two-way ANOVA for controller ratings. The  $F$  statistics indicate that participants felt they performed better and rated their overall situational awareness higher when they were working traffic in dynamic resectorization scenarios regardless of traffic situation. There were no significant interactions between Airspace Type and Traffic Situation for these two measures. Figure 12 and Figure 13 illustrate these main effects.

Table 13.  $F$  Statistics Obtained from the Two-Way ANOVA Performed on the Post-Scenario Questionnaire Ratings

Rating	Main Effect: Airspace	Main Effect: Traffic	Interaction Effect
1. How coordination was affected	$F(1, 11) = 3.34$	$F(1, 11) = 18.54^{**}$	$F(1, 11) = 11.65^{**}$
2. Scenario difficulty	$F(1, 11) = 13.19^{**}$	$F(1, 11) = 21.33^{**}$	$F(1, 11) = 5.65$
3. Performance	$F(1, 11) = 12.20^{**}$	$F(1, 11) = 2.69$	$F(1, 11) = 3.81$
4. Overall situational awareness	$F(1, 11) = 5.68^*$	$F(1, 11) = 1.17$	$F(1, 11) = 0.09$
5. Overall physical/mental workload	$F(1, 11) = 2.94$	$F(1, 11) = 22.00^{**}$	$F(1, 11) = 0.00$
6. Traffic flow realism	$F(1, 11) = 2.58$	$F(1, 11) = 1.20$	$F(1, 11) = 3.12$
7. Simulation pilot performance	$F(1, 11) = 0.08$	$F(1, 11) = 1.07$	$F(1, 11) = 0.48$

\* indicates a statistically reliable effect at a significance level of  $p < .05$   
 \*\* indicates a statistically reliable effect at a significance level of  $p < .01$

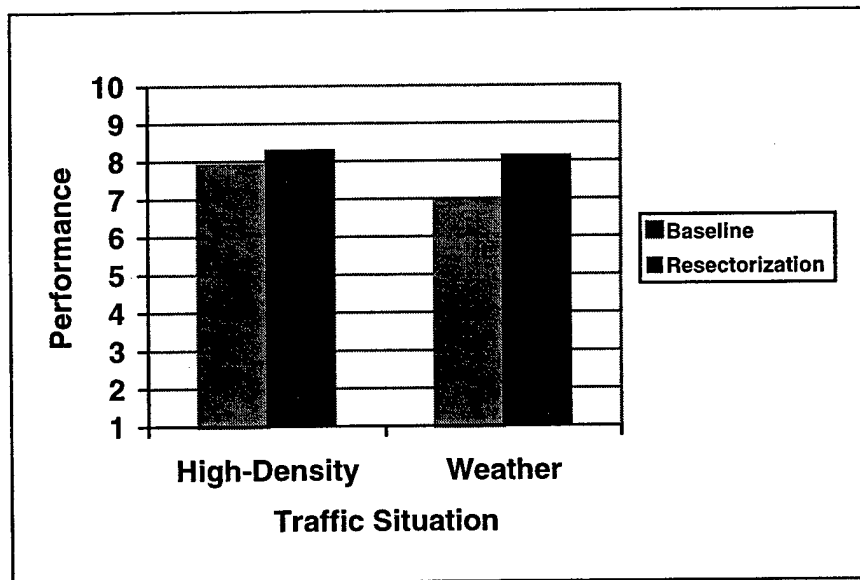

Figure 12. Post-Scenario Questionnaire ratings of performance.

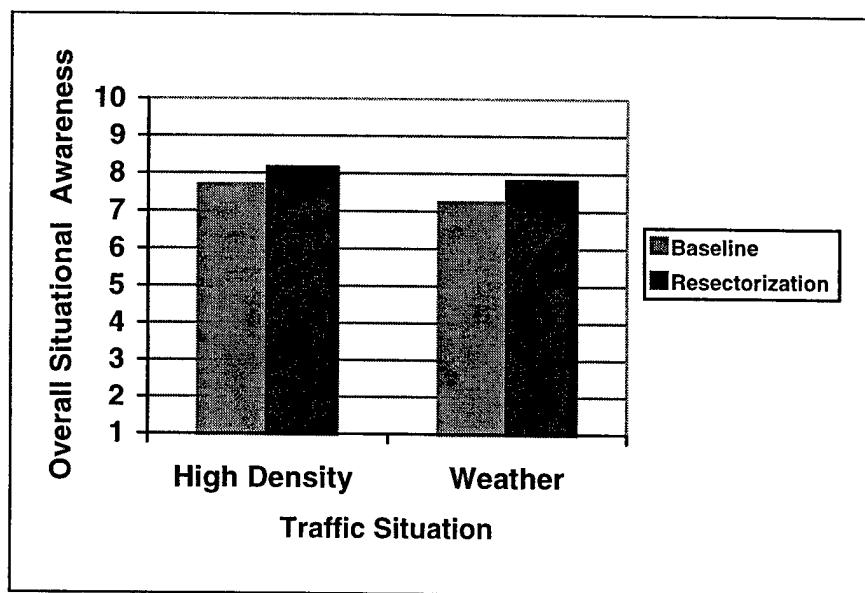

Figure 13. Post-Scenario Questionnaire ratings of situational awareness.

This two-way ANOVA did reveal significant interactions for ratings on coordination and scenario difficulty as a function of Airspace Type and Traffic Situation. Table 14 and Table 15 show the results of the analysis of simple main effects. The  $F$  statistics indicate that baseline airspace configuration had more of an impact on participant coordination but only for the weather traffic situation [ $F(1,11) = 13.82$ ]. For scenario difficulty, the  $F$  statistics revealed that controllers rated the weather scenario in the baseline airspace configuration as significantly more difficult than the same weather scenario in the dynamic airspace configuration. Figure 14 and Figure 15 illustrate these two interactions.

Table 14. Mean Post-Scenario Ratings of Coordination and  $F$  Statistics Obtained from the Analysis of Simple Main Effects

High Density			Weather		
Baseline	Dynamic	$F$ Statistics	Baseline	Dynamic	$F$ Statistics
4.83	4.96	0.08	7.00	5.62	13.82**

\* indicates a statistically reliable effect at a significance level of  $p < .05$   
 \*\* indicates a statistically reliable effect at a significance level of  $p < .01$

Table 15. Mean Post-Scenario Ratings of Scenario Difficulty and  $F$  Statistics Obtained from the Analysis of Simple Main Effects

High Density			Weather		
Baseline	Dynamic	$F$ Statistics	Baseline	Dynamic	$F$ Statistics
6.13	5.67	1.19	7.67	6.13	26.65**

\* indicates a statistically reliable effect at a significance level of  $p < .05$   
 \*\* indicates a statistically reliable effect at a significance level of  $p < .01$

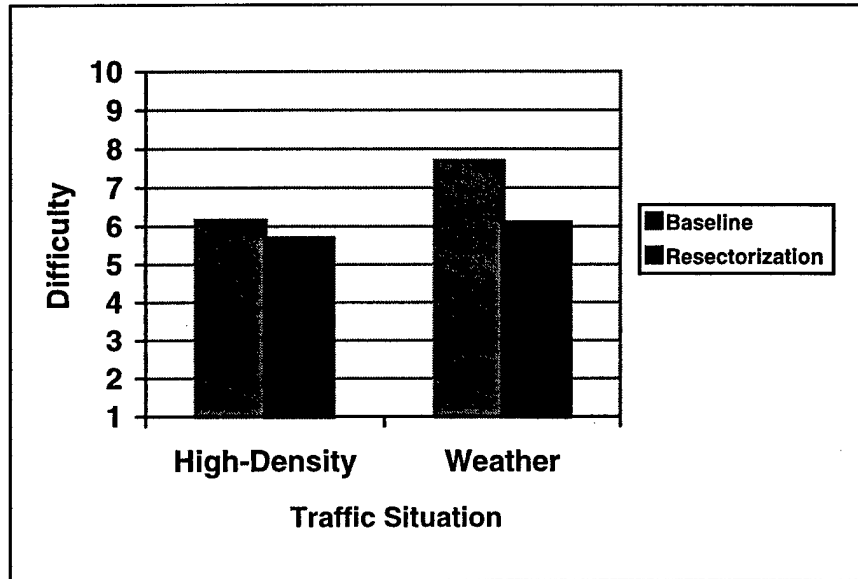

Figure 14. Airspace type by traffic situation interaction for overall coordination.

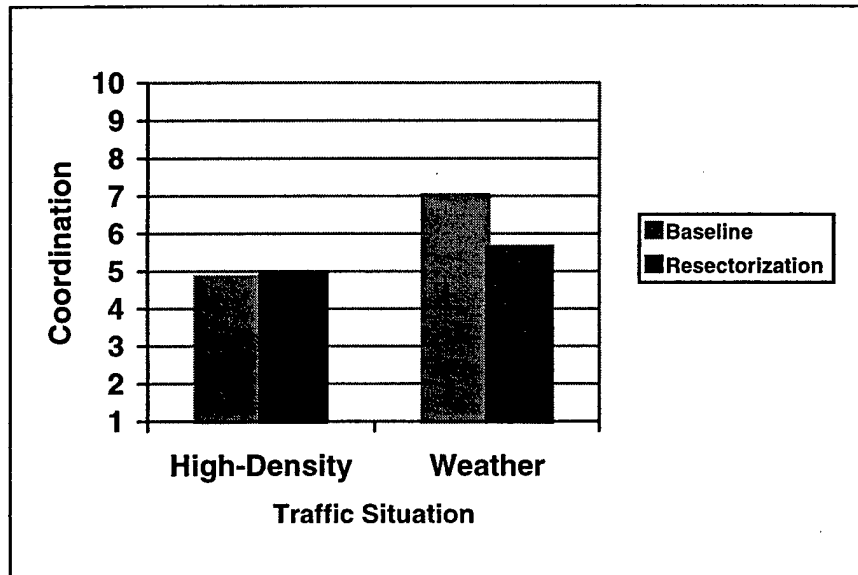

Figure 15. Airspace type by traffic situation interaction for difficulty.

The Post-Scenario Questionnaire Items 9, 10, 11, and 12 were to be filled out only if the participant had just completed a scenario in which dynamic resectorization had occurred. We assumed that during the period of the scenario in which a boundary adjustment was employed, there was a potential for confusion. Those four questions focused on that important transition time. Table 16 shows the controller responses to this portion of the Post-Scenario Questionnaire. Combining the ratings from both ZNO and ZSO does not accurately show the impact on human performance, therefore the ratings have been broken down by ARTCC and also by scenario. We conducted multiple dependent *t*-tests on these ratings and found no questions to differ as a

Table 16. Post-Scenario Questionnaire Resectorization Ratings

Question	Scale Anchors		Grand Mean (SD)	Scenario	ZNO Mean (SD)	ZSO Mean (SD)	t-value
	(1) Extremely negative	(10) Extremely positive					
9. During the time of the boundary adjustment, what was the <b>effect on your performance</b> ?	(1) Extremely negative	(10) Extremely positive	6.65 (2.06)	High Density	7.00 (2.13)	6.16 (1.85)	$t(11) = 0.99$
				Weather	7.00 (2.13)	6.41 (2.23)	$t(11) = 1.13$
10. During the time of the boundary adjustment, what was the <b>effect on your physical and mental workload</b> ?	(1) Extremely negative	(10) Extremely positive	6.21 (1.99)	High Density	6.67 (2.38)	5.58 (1.24)	$t(11) = 1.78$
				Weather	6.67 (1.96)	5.91 (2.23)	$t(11) = 1.43$
11. During the time of the boundary adjustment, <b>how difficult was it to maintain your situational awareness</b> ?	(1) Not very difficult	(10) Extremely difficult	3.00 (1.75)	High Density	2.66 (1.55)	3.25 (2.30)	$t(11) = 0.21$
				Weather	3.41 (1.67)	2.66 (1.43)	$t(11) = 1.56$
12. During the time of the boundary adjustment, to what <b>extent was your coordination affected</b> ?	(1) Very little	(10) A great deal	4.37 (2.41)	High Density	3.75 (2.63)	3.75 (2.63)	$t(11) = -.72$
				Weather	5.83 (2.58)	3.83 (2.08)	$t(11) = 1.97$

function of what ARTCC and/or scenario the participants were working. Overall, however, controllers rated that the dynamic resectorization process had only a positive effect on their performance and workload. For the most part, they felt that it was not very difficult to maintain their situational awareness and that the process had little or no impact on their coordination.

### 3.3.4 Exit Questionnaire

Table 17 shows the controller responses to questions in the exit questionnaire. As shown, controllers found the simulation to be realistic and the dynamic resectorization concept to be feasible within the NAS. Controllers also indicated that the ATWIT procedure did not interfere with their performance. In addition, they felt a positive impact on their performance when dynamic resectorization was employed regardless of which ARTCC they were working.

Table 17. Exit Questionnaire Ratings

Question	Scale Anchors		Mean (SD)
	(1) Not very realistic	(10) Extremely realistic	
1. In general, how realistic was the simulation?	(1) Not very realistic	(10) Extremely realistic	8.00 (1.41)
2. To what extent did the ATWIT probe technique interfere with your performance?	(1) Not very much	(10) A great deal	1.91 (1.37)
3. While you were controlling traffic in ZNO, what type of impact did the boundary adjustment have on your performance?	(1) Very negative	(10) Very positive	7.75 (2.22)
4. While you were controlling traffic in ZSO, what type of impact did the boundary adjustment have on your performance?	(1) Very negative	(10) Very positive	6.75 (2.34)
5. Circle the number that best describes the feasibility of inter-facility boundary adjustment in the National Airspace System?	(1) Not very feasible	(10) Extremely feasible	7.08 (3.02)

#### 4. Discussion and Conclusions

The present study investigated the concept of dynamic resectorization on controller performance, workload, and situation awareness. Our approach was to create ideal conditions (high-density traffic and severe weather) for dynamic resectorization between two adjacent ARTCCs. In both cases, the problem traffic situation was created in the ZNO, and a resectorization of airspace with the adjacent ZSO was the solution.

Airspace Type did have an effect on the system effectiveness measures. Although there were few separation losses overall, controllers recorded the majority during the high-density traffic situation operating in the baseline airspace configuration. It was not statistically significant, but there was an indication that participants had fewer separation losses in the high-density traffic situation under the dynamic resectorization configuration. Controllers had the same amount of separation losses during the weather situation regardless of Airspace Type.

On the surface, given the high quality of the controllers and the total number of simulation runs (96), the overall number of errors does seem somewhat high. One important note is that no conflict resulted in an aircraft proximity index<sup>3</sup> value above two (very low on the 100-pt scale). Simulation fidelity is always an issue and concern. Controllers reported that the simulation was

<sup>3</sup> Aircraft Proximity Index (API) - a weighted measure of conflict intensity where 100 is a mid-air collision and 1 is a minor violation of the separation standards.

realistic. We asked the controllers to work in novel conditions, and this could have increased the error rate somewhat.

In general, capacity remained constant because controllers did not hold traffic. However, there were differences in efficiency indicators. Significant interactions of Airspace Type by Traffic Situation were obtained for frequency and duration of landline communications (NLL and DLL, respectively). These results for the weather scenario are rather clear. In the baseline airspace configuration, the ZNO controller had to point out each aircraft that was deviating around the thunderstorms. Each point-out required a land line communication with ZSO. This coordination was eliminated in the dynamic resectorization configuration because the ZNO controller acquired a portion of ZSO, thus reducing land line communication.

The high-density scenario played out somewhat differently. There was a significant increase in NLL and DLL in the dynamic resectorization configuration for this traffic situation. Overall, there were few land line communications during the high-density scenario regardless of Airspace Type. However, when dynamic resectorization was called for, there were between three and five (depending upon individual controller style) aircraft in the northeast corridor. As part of the dynamic resectorization procedures, aircraft within the portion of airspace that was being resectorized required coordination. This resulted in small, yet significant, increases in both frequency and duration of land-line communications for the high-density traffic situation in the dynamic resectorization configuration. The relationship between sector structure, resectorization, and communication is complicated.

The observer ratings of controller performance varied as a function of Airspace Type for about half of the different rating scales included in the OTS rating form. For these significant differences, ratings were lower when participants were controlling traffic in the baseline airspace configuration. The SMEs were involved in the simulation from the initial stages of experimental design to the airspace and scenario construction. Therefore, one may suggest some sort of observer bias in these participant performance ratings. However, the subjective observer ratings were consistent with the objective system effectiveness measures and both indicated that dynamic resectorization did not interfere with controller performance. Furthermore, the observer ratings were consistent with the participant's self-ratings of workload, performance, and situation awareness.

Participants and observers saw resectorization as positive. They expressed the belief that it reduced their workload. Participant perception did vary somewhat from real time ATWIT to post hoc TLX metrics. When they had time to think about the impact of resectorization, their views were somewhat more positive than when they were still working traffic. The TLX data revealed significant decreases in subjective workload while operating in the dynamic resectorization configuration regardless of scenario type, but the ATWIT data showed little movement. An examination of the mean ATWIT ratings over time revealed that, in the high density scenario under baseline airspace conditions, the workload ratings in ZNO climbed sharply during the first 15 minutes of the scenario where they remained for the duration. The ZSO ratings rose initially in the first 10 minutes and plateaued at a lower level until near the end of the scenario where they began to drop somewhat. During the same traffic situation under the resectorized airspace, the ZNO ratings over time were significantly less, but the interesting difference for ZSO was the noticeable spike in the ATWIT ratings for the prompt following the

acquisition of the northeast corridor. Initially, controllers in ZSO felt that gaining the northeast corridor added to their workload. However, their ratings then dropped and closely mirrored the ZNO ratings for the duration of the scenario. Although the differences in the high-density scenario between airspace types were in the right direction, they were not significant. These results could possibly be attributed to either the operational transition or the scenario design.

We created optimal situations for dynamic resectorization. Ideally, dynamic resectorization would be employed between facilities when one ARTCC is predicted to exceed capacity while an adjacent ARTCC is operating well below capacity. This particular scenario is difficult to examine in a simulation. One way to examine this may be to create a baseline situation in which one participant would be struggling with heavy traffic flow while the other would be bored with light traffic flow. In order to avoid this potential problem, we had the ZSO controller working a moderate amount of traffic while the ZNO controller had a high traffic count. Past simulation experience suggests that it is not generally in anyone's interests to put a controller potentially over the line of his/her capabilities. The current study was basically a compromise design, which likely mirrors some but not all real world conditions.

In the weather scenario, there was a small yet significant decrease in real-time workload ratings in the dynamic resectorization configuration. The mean ratings over time indicate that the allocation of thunder alley from ZSO to ZNO resulted in a subsequent decrease in ratings obtained from ZSO while the ZNO ratings remained fairly consistent with the ratings obtained from the same traffic situation when resectorization did not take place. While the research team designed the traffic problem for the ZNO, the baseline ATWIT ratings over time indicate that the weather scenario was also somewhat of a problem for the ZSO. Resectorization appears to have solved this problem, at least in terms of workload ratings for ZSO. However, ZNO workload ratings do not appear to differ as a function of resectorization.

Overall, the objective and subjective data collected during this experiment support the fact that resectorization did not interfere with performance. In addition, the post-scenario estimates of workload declined in the scenarios in which dynamic resectorization was implemented. Most importantly, the results from this study indicated that if resectorization is accomplished in a timely manner, it does not negatively impact the controller whatsoever. Of course, the research team in the present study investigated a specific type of resectorization using predefined regions of airspace in conditions that were designed to be optimal for resectorization to take place.

However, several studies are needed to explore different approaches to dynamic resectorization. In addition, there are a number of operational and technical questions that need to be addressed. In particular, when should you resectorize? The goal of investigating this question is to determine the optimum point for resectorization to occur. Too early, is an inefficient use of resources, while changing airspace after the controller(s) is/are already busy may have negative consequences in terms of his/her ability to safely and efficiently control traffic. A predictive capability, such as a measure of airspace complexity (i.e., dynamic density), would not only have to account for the sector complexity at some predetermined look-ahead time but would also be required to incorporate the transition time of the system to accommodate the resectorization process. For example, if a dynamic density index indicated that the sector complexity was going to exceed a given threshold in xx minutes and the transition period for the resectorization process is 30 minutes, then the controller working this sector should receive notification 30 +xx minutes

in advance. Is this amount of time sufficient for the controller to work in and become comfortable with this new airspace configuration before the predicted rush? This amount of time may be more than adequate, or controllers may require considerably more time to become accustomed. It is this period of time that needs to be addressed in simulation.

Another question includes how often can you resectorize? Requiring a controller to work multiple airspace configurations during his/her shift is probably not feasible. There is no value added in changing airspace boundaries to accommodate a traffic push that is projected to last for only a short time or to re-route traffic around a small weather cell. In terms of safety and efficiency, what is the minimum period of time a traffic push or weather cell has to be present in order to warrant a resectorization, considering not only the limitations of automation but also without compromising the controllers ability to maintain situation awareness?

Some other questions include how to resectorize? Should airspace boundaries be set up in such a way as to offer an infinite number of configuration capabilities (rubber band or jello sectors), or should resectorization occur within predefined regions of airspace? Incremental airspace resectorization within a specified period of time may not be as easy for the controller to maintain his/her comfort level, especially in an airspace with a high degree of complexity. Predefined regions of airspace offer advantages in terms of training and simplicity. However, these defined regions may work well with aircraft flying fixed routes, but what about when they are on wind optimized or user-preferred routes? Other questions consider the changes in procedures, automation, and communications that need to be addressed and may only be able to be examined in simulation. For example, what role does commonly-used types of procedures (i.e., crossing restrictions) play in structuring traffic and reducing complexity? How does using such procedures constrain dynamic resectorization? Under what conditions might dynamic resectorization result in the need to revise or create a procedure? If/when revised or new procedures are needed to complement a dynamic resectorization, how are they redefined and distributed dynamically? Under what conditions can dynamic resectorization remove the need for an active flow restriction, or what conditions might dynamic resectorization result in the need to revise or create a traffic flow restriction?

Furthermore, what are the automation requirements to support dynamic resectorization? All messages, including text messages and display commands, must be rerouted at the moment of airspace change activation. If flight strips are still in use, any reposting and reprinting of strips must be controlled to ensure appropriately posted strips and minimum disruption on the strip board. Automated hand-off capabilities must be equal, and support tools, such as conflict probe, Traffic Management Advisor, and datalink need to be supported. The number of sector configurations must be supported by computer capacity, number of sector displays, and number of operational positions.

The present study identified specific high density traffic and weather situations that can benefit from dynamic resectorization. Yet, dynamic resectorization may not be effective for all traffic situations. It is important to identify situations where dynamic resectorization may be beneficial and situations where resectorization should not be made.

## References

- ATCoach (Version 7) [Computer Software]. (1996). Lexington, MA: UFA, Inc.
- Buckley, E. P., DeBaryshe, B. D., Hitchner, N., & Kohn, P. (1983). *Methods and measurements in real-time air traffic control system simulation* (DOT/FAA/CT-TN83/26). Atlantic City International Airport, NJ: DOT/FAA Technical Center.
- Carlson, L. S., & Rhodes, L. R. (1998). *Adaptive airspace management: Current field applications and recommended next steps* (MP 98W0000125). McLean, VA: The MITRE Corporation.
- Eurocontrol. (1998). *Air Traffic Management Strategy for 2000+*. Brussels, Belgium: Author.
- FAA (2000). *Air Traffic Control* (DOT/FAA Handbook 7110.65M). Washington, D.C.: U.S. Government Printing Office.
- Goldberg, J. H., & Eberlin, H. W. (1997). Dynamic sectors: Concept development and modeling. *42<sup>nd</sup> Annual Air Traffic Control Association Conference Proceedings*.
- Guttman, J., Stein, E. S., & Gromelski, S. (1995). *The influence of generic airspace on air traffic controller performance* (DOT/FAA/CT-TN95/38). Atlantic City International Airport, NJ: DOT/FAA Technical Center.
- Hart, S. G., & Staveland, L. E. (1988). Development of NASA-TLX (Task Load Index): Results of empirical and theoretical research. In P. A. Hancock and N. Meshkati (Eds.) *Human Mental Workload*. Amsterdam: North.
- Honeywell, Inc. (1997). *Advanced air traffic technologies: Economic and technical modeling report* (NAS2-14279). Moffett Field, CA: NASA Ames.
- Pawlak, W. S., Bowles, A., Goel, V., & Brinton, C. B. (1997). *Initial evaluation of the Dynamic resectorization and route coordination (DIRECT) system concept* (NASA Final Report #NAS2-97057). Boulder, CO: Wyndemere, Inc.
- Planzer, N., & Jenny, M. T. (1995). Managing the evolution to free flight. *Journal of Air Traffic Control*, 37(1), 18-20.
- RTCA (1995a). Report of the RTCA Board of Directors Select Committee of Free Flight. Washington, DC: Author.
- RTCA (1995b). *Free Flight Implementation. RTCA Task Force 3 Report*. Washington, DC: Author
- Sollenberger, R. L., Stein, E. S., & Gromelski, S. (1997). *The development and evaluation of a behaviorally based rating form for the assessment of air traffic controller performance* (DOT/FAA/CT-TN96/16). Atlantic City International Airport, NJ: DOT/FAA William J. Hughes Technical Center.

- Stein, E. S. (1985). *Air traffic controller workload: An examination of workload probe* (DOT/FAA/CT-TN84/24). Atlantic City International Airport, NJ: DOT/FAA Technical Center.
- Vardaman, J. J., & Stein, E. S. (1998). *The development and evaluation of a behaviorally based rating form for the assessment of en route air traffic controller performance* (DOT/FAA/CT-TN98/5). Atlantic City International Airport, NJ: DOT/FAA William J. Hughes Technical Center.
- Wickens, C. D., Mavor, A. S., Parasuraman, R., & McGee, J. P. (Eds.). (1998). *The future of air traffic control: Human operators and automation*. Washington, DC: National Academy Press.

## Appendix A

### INFORMED CONSENT

I, \_\_\_\_\_, understand that this study, entitled "Inter-Facility Boundary Adjustment" is sponsored by the Federal Aviation Administration and is being directed by Dr. Earl Stein.

#### **Nature and Purpose:**

*I have been recruited to volunteer as a participant in the project named above. The purpose of this study is to conduct a human factors evaluation of the potential impact on adjacent center controllers operating in adaptive sectors using real-time air traffic control (ATC) simulation. This study will compare operations between a dynamic en route airspace to using a standard en route airspace with fixed boundaries. The research team will use the data gathered from this simulation to provide input on the viability of developing and implementing inter-facility adaptive en route sector boundaries.*

#### **Experimental Procedures:**

*Participants will conduct traffic in two different experimental conditions for this simulation. In the first condition, controllers will employ a boundary adjustment between the two Centers. The second condition will involve current operating procedures for controlling and directing traffic between Center facilities, and will serve as a baseline for comparison. Each day of the simulation, controllers will work four different traffic scenarios with realistic traffic levels for an en route sector. Two of the scenarios will consist of rather heavy traffic and two will be a combination of medium traffic accompanied by a severe weather system.*

*An automated data collection system will record important simulation events and produce a set of system effectiveness measures, which include safety, capacity, efficiency, and controller workload. In addition, SATCSs will make over-the-shoulder observations to evaluate controller effectiveness while operating in an adaptive airspace. After each scenario, controllers will complete questionnaires to evaluate the benefits of boundary adjustments between facilities. The simulation will be audio-video recorded for the purposes of post experiment content analysis of controller communications.*

#### **Discomfort and Risks:**

*I understand that I will not be exposed to any foreseeable risks or intrusive measurement techniques.*

#### **Benefits:**

*I understand that the only benefit to me is that I will have the opportunity to provide feedback and valuable insight on the feasibility of Inter-Facility Boundary Adjustment to the research team conducting the simulation.*

**Subject Responsibilities:**

I am aware that to participate in this study that I am required to have 20/30 normal or corrected-to-normal vision, and not to be on any medical waiver.

**Compensation and Injury:**

I agree to immediately report any injury or suspected adverse effect to Dr. Randy Sollenberger at (609)-485-7169. Local clinics and hospitals would provide any necessary treatment. I agree to provide, if requested, copies of all insurance and medical records arising from any such care for injuries/medical problems.

**Subject's Assurances:**

I understand that my participation in this study is completely voluntary. I am participating because I want to. Dr. Sollenberger has adequately answered any and all questions I have about this study, my participation, and the procedures involved. I understand that Dr. Sollenberger will be available to answer any questions concerning procedures throughout this study.

I understand that if new findings develop during the course of this research that may relate to my decision to continue participation, I will be informed.

I have not given up any of my legal rights or released any individual or institution from liability for negligence.

Participation in this experiment is strictly voluntary and I have the freedom to withdraw at any time without penalty. I also understand that the researcher of this study may terminate my participation if he feels this to be in my best interest. My participation is strictly confidential, and no individual names or identities will be recorded or released in any reports.

If I have questions about this study or need to report any adverse effects from the research procedures, I will contact Dr. Sollenberger at 609-485-7169(w) 609-476-2745(h).

**Signature Lines:**

*I have read this consent document. I understand its contents, and I freely consent to participate in this study under the conditions described. I have received a copy of this consent form.*

Research Participant: \_\_\_\_\_ Date: \_\_\_\_\_

Investigator: \_\_\_\_\_ Date: \_\_\_\_\_

Witness: \_\_\_\_\_ Date: \_\_\_\_\_

## Appendix B

### Scenario Presentation Order

Controller	1st	2nd	3rd	4th	5th	6th	7th	8th
S01	RZHD-A (1)	STWx-A (1)	STHD-A (1)	RZWx-A (1)	RZHD-B (1)	STWx-B (1)	STHD-B (1)	RZWx-B (1)
S02	RZHD-B (2)	STWx-B (2)	STHD-B (2)	RZWx-B (2)	RZHD-A (2)	STWx-A (2)	STHD-A (2)	RZWx-A (2)
S03	STHD-A (1)	STWx-A (1)	RZHD-A (1)	RZWx-A (1)	STHD-B (1)	STWx-B (1)	RZHD-B (1)	RZWx-B (1)
S04	STHD-B (2)	STWx-B (2)	RZHD-B (2)	RZWx-B (2)	STHD-A (2)	STWx-A (2)	RZHD-A (2)	RZWx-A (2)
S05	STHD-A (1)	RZWx-A (1)	RZHD-A (1)	STWx-A (1)	STHD-B (1)	RZWx-B (1)	RZHD-B (1)	STWx-B (1)
S06	STHD-B (2)	RZWx-B (2)	RZHD-B (2)	STWx-B (2)	STHD-A (2)	RZWx-A (2)	RZHD-A (2)	STWx-A (2)
S07	STWx-A (1)	STHD-A (1)	RZWx-A (1)	RZHD-A (1)	STWx-B (1)	STHD-B (1)	RZWx-B (1)	RZHD-B (1)
S08	STWx-B (2)	STHD-B (2)	RZWx-B (2)	RZHD-B (2)	STWx-A (2)	STHD-A (2)	RZWx-A (2)	RZHD-A (2)
S09	RZHD-A (1)	RZWx-A (1)	STHD-A (1)	STWx-A (1)	RZHD-B (1)	RZWx-B (1)	STHD-B (1)	STWx-B (1)
S10	RZHD-B (2)	RZWx-B (2)	STHD-B (2)	STWx-B (2)	RZHD-A (2)	RZWx-A (2)	STHD-A (2)	STWx-A (2)
S11	RZWx-A (1)	RZHD-A (1)	STWx-A (1)	STHD-A (1)	RZWx-B (1)	RZHD-B (1)	STWx-B (1)	STHD-B (1)
S12	RZWx-B (2)	RZHD-B (2)	STWx-B (2)	STHD-B (2)	RZWx-A (2)	RZHD-A (2)	STWx-A (2)	STHD-A (2)

Note: The designators STHD and STWx indicate baseline airspace boundaries for the high-density scenario and weather scenario, respectively. The designators RZHD and RZWx indicate dynamic resectorization for the high-density scenario and weather scenario, respectively. The letters A and B indicate ZNO airspace and ZSO airspace, respectively. The numbers (1) and (2) identify the SMEs observing the controllers.

## Appendix C

### Subject Matter Expert Observer Rating Form

Observer Code \_\_\_\_\_

Date \_\_\_\_\_

#### INSTRUCTIONS

This form is designed to be used by supervisory air traffic control specialists to evaluate the effectiveness of controllers working in simulation environments. SATCSs will observe and rate the performance of controllers in several different performance dimensions using the scale below as a general purpose guide. Use the entire scale range as much as possible. You will see a wide range of controller performance. Take extensive notes on what you see. Do not depend on your memory. Write down your observations. Space is provided after each scale for comments. You may make preliminary ratings during the course of the scenario. However, wait until the scenario is finished before making your final ratings and remain flexible until the end when you have had an opportunity to see all the available behavior. At all times, please focus on what you actually see and hear. This includes what the controller does and what you might reasonably infer from the actions of the pilots. Try to avoid inferring what you think may be happening. If you do not observe relevant behavior or the results of that behavior, then you may leave a specific rating blank. Also, please write down any comments that may help improve this evaluation form. Do not write your name on the form itself. Your identity will remain anonymous, as your data will be identified by an code known only to yourself and the researchers conducting this study. The observations you make do not need to be restricted to the performance areas covered in this form and may include other areas that you think are important.

#### ASSUMPTIONS

ATC is a complex activity that contains both observable and unobservable behavior. There are so many complex behaviors involved that no observational rating form can cover everything. A sample of the behaviors is the best that can be achieved, and a good form focuses on those behaviors that controllers themselves have identified as the most relevant in terms of their overall performance. Most controller performance is at or above the minimum standards regarding safety and efficiency. The goal of the rating system is to differentiate performance above this minimum. The lowest rating should be assigned for meeting minimum standards and also for anything below the minimum since this should be a rare event. It is important for the observer/rater to feel comfortable using the entire scale and to understand that all ratings should be based on behavior that is actually observed.

## Rating Scale Descriptors

*Remove this Page and keep it available while doing ratings*

SCALE	QUALITY	SUPPLEMENTARY
1	<b>Least Effective</b>	Unconfident, Indecisive, Inefficient, Disorganized, Behind the power curve, Rough, Leaves some tasks incomplete, Makes mistakes
2	<b>Poor</b>	May issue conflicting instructions, Doesn't plan completely
3	<b>Fair</b>	Distracted between tasks
4	<b>Low Satisfactory</b>	Postpones routine actions
5	<b>High Satisfactory</b>	Knows the job fairly well
6	<b>Good</b>	Works steadily, Solves most problems
7	<b>Very Good</b>	Knows the job thoroughly, Plans well
8	<b>Most Effective</b>	Confident, Decisive, Efficient, Organized, Ahead of the power curve, Smooth, Completes all necessary tasks, Makes no mistakes

# **I - MAINTAINING SAFE AND EFFICIENT TRAFFIC FLOW**

1. Maintaining Separation and Resolving Potential Conflicts ..... 1 2 3 4 5 6 7 8
- using control instructions that maintain appropriate aircraft and airspace separation
  - detecting and resolving impending conflicts early
  - recognizing the need for speed restrictions and wake turbulence separation

Comments:

2. Sequencing Aircraft Efficiently ..... 1 2 3 4 5 6 7 8
- using efficient and orderly spacing techniques for arrival, departure, and en route aircraft
  - maintaining safe arrival and departure intervals that minimize delays

Comments:

3. Using Control Instructions Effectively/Efficiently ..... 1 2 3 4 5 6 7 8
- providing accurate navigational assistance to pilots
  - issuing economical clearances that result in need for few additional instructions to handle aircraft completely
  - ensuring clearances use minimum necessary flight path changes

Comments:

4. Overall Safe and Efficient Traffic Flow Scale Rating ..... 1 2 3 4 5 6 7 8

Comments:

## II - MAINTAINING ATTENTION AND SITUATION AWARENESS

5. Maintaining Awareness of Aircraft Positions..... 1 2 3 4 5 6 7 8
- avoiding fixation on one area of the radar scope when other areas need attention
  - using scanning patterns that monitor all aircraft on the radar scope

Comments:

6. Ensuring Positive Control ..... 1 2 3 4 5 6 7 8
- tailoring control actions to situation
  - using effective procedures for handling heavy, emergency, and unusual traffic situations

Comments:

7. Detecting Pilot Deviations from Control Instructions ..... 1 2 3 4 5 6 7 8
- ensuring that pilots follow assigned clearances correctly
  - correcting pilot deviations in a timely manner

Comments:

8. Correcting Own Errors in a Timely Manner..... 1 2 3 4 5 6 7 8
- acting quickly to correct errors
  - changing an issued clearance when necessary to expedite traffic flow

Comments:

9. Overall Attention and Situation Awareness Scale Rating ..... 1 2 3 4 5 6 7 8

Comments:

### III – PRIORITIZING

10. Taking Actions in an Appropriate Order of Importance.....1 2 3 4 5 6 7 8
- resolving situations that need immediate attention before handling low priority tasks
  - issuing control instructions in a prioritized, structured, and timely manner

Comments:

11. Preplanning Control Actions..... 1 2 3 4 5 6 7 8
- scanning adjacent sectors to plan for future and conflicting traffic
  - studying pending flight strips in bay

Comments

12. Handling Control Tasks for Several Aircraft..... 1 2 3 4 5 6 7 8
- shifting control tasks between several aircraft when necessary
  - communicating in timely fashion while sharing time with other actions

Comments:

13. Marking Flight Strips while Performing Other Tasks ..... 1 2 3 4 5 6 7 8
- marking flight strips accurately while talking or performing other tasks
  - keeping flight strips current

Comments:

14. Overall Prioritizing Scale Rating ..... 1 2 3 4 5 6 7 8

Comments:

## **IV – PROVIDING CONTROL INFORMATION**

15. Providing Essential Air Traffic Control Information..... **1 2 3 4 5 6 7 8**
- providing mandatory services and advisories to pilots in a timely manner
  - exchanging essential information

Comments:

16. Providing Additional Air Traffic Control Information..... **1 2 3 4 5 6 7 8**
- providing additional services when workload is not a factor
  - exchanging additional information

Comments:

17. Providing Coordination..... **1 2 3 4 5 6 7 8**
- providing effective and timely coordination
  - using proper point-out procedures

Comments:

18. Overall Providing Control Information Scale Rating .....**1 2 3 4 5 6 7 8**

Comments:

## V – TECHNICAL KNOWLEDGE

19. Showing Knowledge of LOAs and SOPs ..... **1 2 3 4 5 6 7 8**
- controlling traffic as depicted in current LOAs and SOPs
  - performing handoff procedures correctly

Comments:

- 20a. Showing Knowledge of Aircraft Capabilities and Limitations..... **1 2 3 4 5 6 7 8**
- using appropriate speed, vectoring, and/or altitude assignments to separate aircraft with varied flight capabilities
  - issuing clearances that are within aircraft performance parameters

Comments:

- 20b. Showing Effective Use of Equipment..... **1 2 3 4 5 6 7 8**
- updating data blocks
  - using equipment capabilities

Comments:

21. Overall Technical Knowledge Scale Rating ..... **1 2 3 4 5 6 7 8**

Comments:

## **VI – COMMUNICATING**

**22. Using Proper Phraseology..... 1 2 3 4 5 6 7 8**

- using words and phrases specified in the 7110.65
- using phraseology that is appropriate for the situation
- using minimum necessary verbiage

Comments:

**23. Communicating Clearly and Efficiently ..... 1 2 3 4 5 6 7 8**

- speaking at the proper volume and rate for pilots to understand
- speaking fluently while scanning or performing other tasks
- ensuring clearance delivery is complete, correct and timely
- speaking with confident, authoritative tone of voice

Comments:

**24. Listening to Pilot Readbacks and Requests ..... 1 2 3 4 5 6 7 8**

- correcting pilot readback errors
- acknowledging pilot or other controller requests promptly
- processing requests correctly in a timely manner

Comments:

**25. Overall Communicating Scale Rating ..... 1 2 3 4 5 6 7 8**

Comments:

Appendix D

Questionnaires

**BACKGROUND QUESTIONNAIRE**

Participant Code \_\_\_\_\_

Date \_\_\_\_\_

**INSTRUCTIONS**

---

This questionnaire is designed to obtain information about your background as an air traffic control specialist. The information will be used to describe the participants in this study as a group in written and/or oral reports. Your identity will remain anonymous, so do not write your name on the form. Instead, your data will be identified by a participant code known only to yourself and the researchers conducting this study.

---

Sex:  male  female

1. What is your job position or title?

\_\_\_\_\_

2. What is your age?

\_\_\_\_\_ years

3. How many years have you worked as an air traffic control specialist?

\_\_\_\_\_ years

4. How many years have you been a Full Performance Level controller?

\_\_\_\_\_ years

5. How many of the past 12 months have you actively controlled traffic?

\_\_\_\_\_ months

6. Please briefly describe your air traffic control training and experience.



5. Please circle the number that best describes **how realistic the traffic flow** in this scenario was.

extremely 1 2 3 4 5 6 7 8 9 10 extremely  
realistic unrealistic

Comments \_\_\_\_\_

6. Please circle the number that best describes **how difficult** this scenario was.

extremely 1 2 3 4 5 6 7 8 9 10 extremely  
easy difficult

Comments \_\_\_\_\_

7. Please circle the number that best describes **how well the simulation-pilots performed** during this scenario.

extremely 1 2 3 4 5 6 7 8 9 10 extremely  
poor well

Comments \_\_\_\_\_

8. Do you have any other comments about your experiences during this scenario?

Comments \_\_\_\_\_

\_\_\_\_\_

\_\_\_\_\_

\_\_\_\_\_

\_\_\_\_\_

COMPLETE THIS LAST SECTION ONLY IF THE SCENARIO YOU JUST FINISHED HAD A BOUNDARY ADJUSTMENT

**THESE QUESTIONS FOCUS ON THE TIME IN THE SCENARIO WHEN THE BOUNDARY ADJUSTMENT WAS IMPLEMENTED**

9. During the time of the boundary adjustment, **what was the effect on your performance?**

extremely 1 2 3 4 5 6 7 8 9 10 extremely  
negative positive

Comments \_\_\_\_\_

10. During the time of the boundary adjustment, **what was the effect on your physical/mental workload?**

extremely 1 2 3 4 5 6 7 8 9 10 extremely  
negative positive

Comments \_\_\_\_\_

11. During the time of the boundary adjustment, **how difficult was it to maintain your situational awareness?**

Not very 1 2 3 4 5 6 7 8 9 10 extremely  
difficult difficult

Comments \_\_\_\_\_

12. During the time of the boundary adjustment, to what **extent was your coordination affected?**

very 1 2 3 4 5 6 7 8 9 10 A great  
little deal

Comments \_\_\_\_\_

# NASA Task Load Index

Participant Code \_\_\_\_\_

Date \_\_\_\_\_

Scenario Code \_\_\_\_\_

## Mental Demand

How much mental and perceptual activity is required (e.g., thinking, deciding, calculating, remembering, looking, searching)? Is the task easy or demanding, simple or complex?

Circle the number that best describes the **mental demand** during this scenario.

extremely 1 2 3 4 5 6 7 8 9 10 extremely  
low high

## Physical Demand

How much physical activity is required (e.g., pushing, turning, controlling, activating)? Is the task easy or demanding, slow or brisk, slack or strenuous?

Circle the number that best describes the **physical demand** during this scenario.

extremely 1 2 3 4 5 6 7 8 9 10 extremely  
low high

## Temporal Demand

How much time pressure do you feel due to the rate or pace at which the task occurred? Is the pace slow and leisurely or rapid and frantic.

Circle the number that best describes the **temporal demand** during this scenario.

extremely 1 2 3 4 5 6 7 8 9 10 extremely  
low high

Performance

How successful do you think you are in accomplishing the goals of the task? How satisfied are you with your performance in accomplishing these goals?

Circle the number that best describes your **performance** during this scenario.

extremely 1 2 3 4 5 6 7 8 9 10 extremely  
low high

Effort

How hard did you have to work (mentally and physically) to accomplish this level of performance?

Circle the number that best describes your **effort** during this scenario.

extremely 1 2 3 4 5 6 7 8 9 10 extremely  
low high

Frustration

How insecure, discouraged, irritated, stressed, and annoyed versus secure, gratified, content, relaxed, and complacent do you feel in performing the task?

Circle the number that best describes your **level of frustration** during this scenario.

extremely 1 2 3 4 5 6 7 8 9 10 extremely  
low high



4. While you were controlling traffic in **ZSO**, what type of impact did the boundary adjustment have on your performance?

very negative    1    2    3    4    5    6    7    8    9    10    very positive

Comments \_\_\_\_\_

5. Circle the number that best describes the feasibility of Inter-Facility boundary adjustment in the National Airspace System (NAS).

Not very feasible    1    2    3    4    5    6    7    8    9    10    extremely feasible

Comments \_\_\_\_\_

6. Describe any situation or conditions where boundary adjustment would be useful in your facility.

Comments \_\_\_\_\_

7. What do you see as the benefits of this concept?

Comments \_\_\_\_\_

## Appendix E

### Inter-Facility Boundary Adjustment Policies and Procedures

Adjusting airspace between the North ARTCC and South ARTCC (ZNO and ZSO) will involve two pre-defined regions within each facility that are stored in the host system. Flight data processing will be automated to coincide with airspace boundary adjustments. The operational advantages stemming from this concept may include

1. reduced controller workload,
  - a. reduced coordination activities
  - b. more balanced traffic
2. greater user flexibility,
  - a. increased preferential routing
  - b. decreased fuel burn
3. reduction in delays,
4. reduced flow restrictions, miles in trail, and
5. increased safety.

Ideally, the Traffic Management Unit (TMU) is the first to recognize the potential need for a boundary adjustment. For the purposes of this simulation, the resectorization process will be driven by the SMEs who are acting as the local TMU. The TMU, using current and projected ETMS and/or NWS/WARP data, will determine the need for a boundary adjustment at a specific time. Timely decisions for resectorization are important. It is critical that the decision to implement a resectorization be made in a timely manner. The actual events that trigger the decision are based on known traffic/weather trends and projected data (time of year, special events, SUA activation, etc.). Using the equipment available, the specialist calculates fix loads and projected track data to determine the most operationally viable time for boundary adjustment. A late call can result in sector complexity that ultimately leads to a loss of situation awareness for the controller(s) working the reconfigured airspace. An early call, however, is an inefficient use of resources.

The two scenarios used in this study are airspace boundary adjustment for weather deviations and an airspace boundary adjustment for traffic density/balancing. In the traffic density scenario, the TMU recognizes the need to resectorize due to a large amount of aircraft projected in ZNO along J1. The facility TMU notifies the area supervisors for ZNO and ZSO. ATCSCC, with input from the local TMU, makes the call on the exact time to resectorize. All parties must concur prior to boundary reconfiguration. When a boundary adjustment is initiated (ZNO allocating the Northeast Corridor to ZSO), the sector boundaries will reconfigure on all displays.

Controllers on the sectors receive 2 min prior notification in this simulation. All hand-offs and communication transfers shall be accomplished during this transition period.

The weather deviation scenario is implemented in the same manner. For this simulation, local weather patterns dictated a region of airspace in ZSO (Thunder Alley) to be allocated to ZNO in order to accommodate deviating traffic along J2, J10, and J20. The local TMU becomes aware of severe weather buildup and makes the call before traffic deviations increase workload due to the large amount of coordination required. The allocation of Thunder Alley to ZNO allows the aircraft that are in close proximity to the weather cells to remain in ZNO (the originating facility). This reduces the multiple handoffs and point outs required as aircraft will no longer be deviating into ZSO airspace. As with the high-density scenario, the controllers on the sectors receive 2 min prior notification to complete hand-offs and communication transfers.