

Serial No.: 08/736,551

Filing Date: 24 OCTOBER 1996

Inventor: THOMAS L. CARROLL

NOTICE

The above identified patent application is available for licensing.
Requests for information should be addressed to:

ASSOCIATE COUNSEL (PATENTS)
CODE 1008.2
NAVAL RESEARCH LABORATORY
WASHINGTON DC 20375

DISTRIBUTION STATEMENT A
Approved for Public Release
Distribution Unlimited

THIS QUALITY PRINTED &

20001208 136

PATENT APPLICATION/TECHNICAL DIGEST PUBLICATION RELEASE REQUEST

FROM: Associate Counsel (Patents) (3008.2)
TO: Associate Counsel (Patents) (3008.2)

Via: (1) Thomas L. Carroll (Code 6341)
(2) Division Superintendent (Code 6300)
(3) Head, Classification Management & Control (Code 1221)

SUBJ: Patent Application/Technical Digest entitled AMPLITUDE
INSENSITIVE SYNCHRONIZATION OF NONLINEAR SYSTEMS request
for release for publication.

REF: (a) NRL Instruction 5510.40C
(b) Chapter 6, ONRINST 5870.1C

ENCL: (1) Copy of patent Application/Technical Digest

1. In accordance with the provision of references (a) and (b), it is hereby requested that the subject Patent Application/Technical Digest be released for publication.
2. It is intended to offer this Patent Application/Technical Digest to the National Technical Information Service, for publication.
3. This request is in connection with Navy Case No. 77,203.

230474
(date)

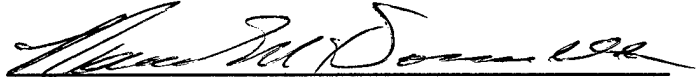
THOMAS E. McDONNELL
Associate Counsel (Patents)

FIRST ENDORSEMENT

Date: 2-19-97

FROM: Thomas L. Carroll (Code 6341)
TO: Division Superintendent (Code 6300)

1. It is the opinion of the Inventor(s) that the subject Patent Application/Technical Digest (is) (is not) classified and there is no objection to public release.



Inventor's Signature

Inventor's Signature

SECOND ENDORSEMENT

Date:

FROM: Division Superintendent (Code 6300)
TO: Classification Management & Control (Code 1221)

1. Release of Patent Application/Technical Digest (is) (is not) approved.
2. To the best knowledge of this Division, the subject matter of this Patent Application/Technical Digest (has) (has not) been classified.
3. This recommendation takes into account military security, sponsor requirements and other administration considerations and there in no objection to public release.

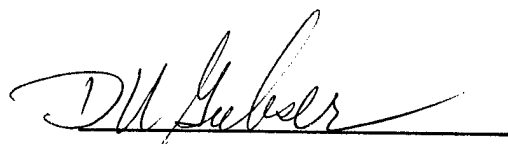

Superintendent

THIRD ENDORSEMENT

Date: 2/24/97

FROM: Head, Classification & Control (Code 1221)
TO: Associate Counsel (Patents) (3008.2)

1. This Patent Application/Technical Digest is authorized for public release.

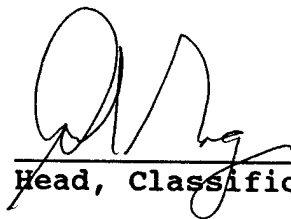

Head, Classification, Management & Control

AMPLITUDE INSENSITIVE SYNCHRONIZATION OF NONLINEAR SYSTEMS

BACKGROUND OF THE INVENTION

1 The present invention relates generally to the synchronization of nonlinear systems and
2 more particularly to a system which allows the synchronization of one nonlinear dynamical or
3 chaotic system to another nonlinear dynamical or chaotic system insensitive to attenuation in the
4 driving signal.

5 A synchronized nonlinear system can be used as an information transfer system. The
6 transmitter, responsive to an information signal, produces a drive signal for transmission to the
7 receiver. An error detector compares the drive signal and the output signal produced by the
8 receiver to produce an error signal indicative of the information contained in the information
9 signal.

10 It is known to those skilled in the art that a nonlinear dynamical system can be driven (the
11 response) with a signal from another nonlinear dynamical system (the drive). With such a
12 configuration the response system actually consist of duplicates of subsystems of the drive system,
13 which are cascaded and the drive signal, or signals, come from parts of the drive system that are
14 included in the response system.

15 A system with extreme sensitivity to initial conditions is considered chaotic. The same
16 chaotic system started at infinitesimally different initial conditions may reach significantly
17 different states after a period of time. Lyapanov exponents (also known in the art as
18 "characteristic exponents") measure this divergence. A system will have a complete set of

Serial No. (unassigned)
Inventor: Thomas Carroll

Patent Application
Attorney Docket No. 77,203

1 Lyapunov exponents, each of which is the average rate of convergence (if negative) or divergence
2 (if positive) of nearby orbits in phase space as expressed in terms of appropriate variables and
3 components.

4 Sub or Conditional Lyapunov exponents are characteristic exponents which depend on the
5 signal driving the system. It is also known to those skilled in the art that, if the sub-Lyapunov,
6 or conditional Lyapunov, exponents for the driven response system are all negative, then all
7 signals in the response system will converge over time or synchronize with the corresponding
8 signals in the drive. When the response system is driven with the proper signal from the drive
9 system, the output of the response system is identical to the input signal. When driven with any
10 other signal, the output from the response is different from the input signal.

11 In brief, a dynamical system can be described by the ordinary differential equation

$$12 \quad \dot{\alpha}(t) = f(\alpha). \quad (1)$$

13 The system is then divided into two subsystems. $\alpha = (\beta, \chi)$;

$$14 \quad \dot{\beta} = g(\beta, \chi)$$

$$15 \quad \dot{\chi} = h(\beta, \chi) \quad (2)$$

16 where $\beta = (\alpha_1, \dots, \alpha_n)$, $g = (f_1(\alpha), \dots, f_n(\alpha))$, $h = (f_{n+1}(\alpha), \dots, f_m(\alpha))$, $\chi = (\alpha_{n+1}, \dots, \alpha_m)$,

17 where α , β and χ are measurable parameters of a system, for example vectors representing a
18 electromagnetic wave.

19 The division is arbitrary since the reordering of the α_i variables before assigning them to
20 β , χ g and h is allowed. A first response system is created by duplicating a new subsystem
21 χ' identical to the χ system, and substituting the set of variables β for the corresponding β' in

1 the function h , and augmenting Eqs. (2) with this new system, giving

$$\begin{aligned} 2 \quad & \dot{\beta} = g(\beta, \chi), \\ 3 \quad & \dot{\chi} = h(\beta, \chi) \quad (3) \\ 4 \quad & \dot{\chi}' = h(\beta, \chi'). \end{aligned}$$

5 If all the sub-Lyapunov exponents of the χ' system (ie. as it is driven) are less than zero,
6 then $[\chi' - \chi] \rightarrow 0$ as $t \rightarrow$ infinity. The variable β is known as the driving signal. One may also
7 reproduce the β subsystem and drive it with the χ' variable, giving

$$\begin{aligned} 8 \quad & \dot{\beta} = g(\beta, \chi), \\ 9 \quad & \dot{\chi} = h(\beta, \chi), \\ 10 \quad & \dot{\chi}' = h(\beta, \chi'). \quad (4) \\ 11 \quad & \dot{\beta}'' = g(\beta'', \chi'). \end{aligned}$$

12 The functions h and g may contain some of the same variables. If all the sub-Lyapunov
13 exponents of the χ' , β'' subsystem (ie. as it is driven) are less than 0, then $\beta'' \rightarrow \beta$ as $t \rightarrow$
14 infinity. The example of the Equ. (4) is referred to as cascaded synchronization.
15 Synchronization is confirmed by comparing the driving signal β with the signal β'' .

16 Generally, since the response system is nonlinear, it will only synchronize to a drive
17 signal with the proper amplitude. If the response system is at some remote location with respect
18 to the drive system, the drive signal will probably be subjected to some unknown attenuation.
19 This attenuation can be problematic to system synchronization.

20 The present invention is a system design featuring subsystems which are nonlinear and
21 possibly chaotic, but will still synchronize when the drive signal is attenuated or amplified by an

Serial No. (unassigned)
Inventor: Thomas Carroll

Patent Application
Attorney Docket No. 77,203

1 unknown amount. This invention builds on the design of two previous inventions, the
2 synchronizing of chaotic systems, US patent 5,245,660, and the cascading of synchronized chaotic
3 systems, US patent 5,379,346, both herein incorporated by reference. The present invention
4 extends those principles to situations where the drive signal has been attenuated by some
5 unknown amount. Applicants overcome this limitation by providing for a nonlinear response
6 system that is not amplitude dependent and a separate function that is part of the drive system
7 only that is amplitude dependent.

8
9 **SUMMARY OF THE INVENTION**

10 Accordingly, it is an object of the present invention to provide a chaotic system which
11 will reproduce a signal that is a scaled version of one or more drive signals even when the drive
12 signal, or signals, are subject to attenuation, fading, and desynchronize this response signal by
13 varying a parameter in the drive or response system.

14 It is also an object of the present invention to provide a chaotic system which will detect
15 the variation of a parameter or parameters in the drive or response systems by detecting
16 desynchronization.

17 A further object of the present invention is to provide a system which will send
18 information on a chaotic carrier in a way that is not sensitive to noise or fading by comparing
19 the input and output of the response system while varying the drive system. These and additional
20 objects of this invention are accomplished by the structures and processes hereinafter described.

21 The present invention is an amplitude insensitive synchronized nonlinear system (AISN)

Serial No. (unassigned)
Inventor: Thomas Carroll

Patent Application
Attorney Docket No. 77,203

1 which allows communication between nonlinear systems operating in the chaotic realm which is
2 largely insensitive to attenuation or signal noise affecting the amplitude of the drive signal,
3 thereby allowing communication between remote systems where the amplitude of the transmitted
4 signal has been varied by an unknown amount.

5 AISN comprises a transmitter system (drive) employing linear or scale invariant nonlinear
6 subsystems, the output of the one driving the other, at least two which are amplitude insensitive
7 in operation. The signal produced by the second scale invariant nonlinear subsystem is then used
8 to drive an amplitude dependent nonlinear function. The amplitude dependent nonlinear function
9 acts to bound the chaotic signal and prevent the signals from diverging uncontrollably, and is
10 designed to have characteristics that ensure a plot of its input vs. output can be related at the
11 same reference point. This is critical because this common reference point serves as a baseline
12 point for one to determine system synchronization. The chaotic transmitter signal produced by
13 the amplitude dependent function is then transmitted to a nonlinear cascaded receiver.

14 AISN employs a receiver (response) which comprises subsystems which are duplicates of
15 the transmitters scale invariant subsystems and are arranged to be responsive to the AISN
16 transmitter. Synchronization is confirmed by sampling the value of the transmitted signal. If the
17 input to the receiver and the output pass through known reference points at the same time, then
18 the transmitter and receiver are known to be synchronized. Information may be encoded by
19 making the output from the receiver go out of synchronization with the input by altering the
20 transmitted signal.

21 The synchronized nonlinear system can be used as an information transfer system. The

1 transmitter, responsive to an information signal, produces a drive signal for transmission to the
2 receiver. An error detector compares the drive signal and the output signal produced by the
3 receiver to produce an error signal indicative of the information contained in the information
4 signal.

5
6 BRIEF DESCRIPTION OF THE DRAWINGS

7
8 Figure 1. is a block diagram of a cascaded synchronized nonlinear system (prior art).
9 Figure 2. is a block diagram of an amplitude insensitive synchronized nonlinear system.
10 Figure 3. is a schematic diagram of an example chaotic drive circuit constructed in accordance
11 with this invention.
12 Figure 4(a). is a graphical representation of input signal Y and the output signal from circuit
13 function $g_1(x)$
14 Figure 4(b). is a graphical representation of input signal X and the output signal from circuit
15 function $g_2(x)$.
16 Figure 4(c). is a graphical representation of input signal Y and the output signal from circuit
17 function $g_3(y)$.
18 Figure 5. is the chaotic attractor from the example drive circuit of figure 3.
19 Figure 6. is a schematic diagram of an example response circuit for figure 3 constructed in
20 accordance with this invention.
21 Figure 7. is a representation of the power spectrum of the transmitted chaotic signal $u=\Gamma g_1(y)$.
22 Figure 8(a). is a plot of the Y signal form the driving circuit vs. the Y' signal from the receiving
23 circuit with a scaling factor of $\Gamma=1.0$.
24 Figure 8(b). is a plot of the Y signal form the driving circuit vs. the Y' signal from the receiving
25 circuit with a scaling factor of $\Gamma=0.2$
26 Figure 9. is the chaotic attractor for the response circuit with a scaling factor of $\Gamma=0.5$.
27 Figure 10. is a plot of the drive signal u_d vs. the output signal Y' from the response circuit.
28 Figure 11. is a schematic diagram of an example of the synchronization detection circuit.
29 Figure 12. is a plot of the low frequency power spectrum of u_d .
30 Figure 13. is a block diagram of an signal transmission system featuring amplitude insensitive
31 chaotic synchronization.

32
33
34 DETAILED DESCRIPTION

35
36 Referring now to the figures, wherein like reference characters indicate like elements

Serial No. (unassigned)

Inventor: Thomas Carroll

Patent Application

Attorney Docket No. 77,203

1 throughout the several views, figure 1 illustrates a block diagram of the basic architecture of a
2 cascaded synchronizing nonlinear system 100 divided into subsystems A 298, B 299, A' 390
3 and B' 399, for producing synchronized communication signals S_B 222 and S_B' 333. The
4 system is a tangible system that can be of any form. Examples of signals, such as signals S_B
5 222 and S_B' 333 can be associated with system 100 can be electrical, optical or other
6 electromagnetic signals, pressure, force temperature, chemical concentration, population or
7 others.

8 Since the response system 300 is nonlinear, it will only synchronize to a drive signal
9 222 from the drive system 200 having the proper amplitude. In other words, for some
10 nonlinear function $f(x)$, rescaling x produces a different result: $f(\Gamma x) \neq \Gamma f(x)$. There are
11 nonlinear functions for which the equality does not hold; for example, if $f(x)$ is polynomial
12 nonlinear, exponentially nonlinear or piecewise linear the desired characteristics are present.
13 For example, if $f(x)$ is piecewise nonlinear, ($f(x)$ may be constructed from the line segments
14 with different slopes) and $f(x)$ has its only break point at the origin, then $f(\Gamma x) = \Gamma f(x)$, so that
15 $f(x)$ is scale invariant. Any amplitude dependent nonlinear function in which the input and
16 output can be related at some point will be acceptable. If one has functions $f(x, y, z)$, $h(x, y,$
17 $z)$, and $u(x, y, z)$ which contain only scale invariant nonlinearities, it is possible to construct a
18 scale-invariant set of differential equations:

1

(5)

$$\frac{d(\Gamma x)}{dt} = \Gamma \frac{dx}{dt} = f(\Gamma x, \Gamma y, \Gamma z) = \Gamma f(x, y, z)$$

$$\frac{d(\Gamma y)}{dt} = \Gamma \frac{dy}{dt} = h(\Gamma x, \Gamma y, \Gamma z) = \Gamma h(x, y, z)$$

$$\frac{d(\Gamma z)}{dt} = \Gamma \frac{dz}{dt} = u(\Gamma x, \Gamma y, \Gamma z) = \Gamma u(x, y, z)$$

2

3 The scale factor Γ will cancel, so that rescaling all of the variables does not affect the
4 dynamics of the system. This relation is also true for a linear set of equations. It is not
5 possible to get chaos out of a scale invariant set of equations such as equation (5). Some
6 instability is necessary for chaos to exist, so that nearby phase space trajectories diverge from
7 each other. The trajectories will diverge to infinity, however, unless some mechanism exists
8 to fold them back when some variable becomes too large. This requires that some part of the
9 differential equations for a chaotic system depend on the amplitude of at least one of the
10 variables. It is useful to isolate the amplitude dependence in one function, $g(x)$ for example.
11 When the chaotic system is constructed properly, then $g(x)$ may also be used as a driving
12 signal to drive a cascaded response system. Figure 2 is a block diagram of such a system.
13 Referring now to figure 2, the signal from B to A in the full chaotic system passes through
14 the amplitude-dependent function g . The signal $S_{g(x)}$ may then be used to drive A' in the
15 response system, which then drives B'. Rather than comparing $S_{B'}$ to S_B to confirm

Serial No. (unassigned)
Inventor: Thomas Carroll

Patent Application
Attorney Docket No. 77,203

1 synchronization, as is Figure 1, synchronization is confirmed by comparing S_B' with $g(x)$. In
2 order to make the detection of synchronization easier, it is useful to make $g(x_0) = \alpha_0$, where
3 α_0 is a known reference point for some x_0 so that the input and output of the response system
4 may be directly compared.

5 If A and B are linear or contain only scale-invariant nonlinearities, then if the driving
6 signal $S_{g(x)}$ is replaced by $\Gamma S_{g(x)}$, the signals in B' and A' will be scaled by Γ relative to the
7 signals in A and B. The use of a function of a variable rather than the variable itself as a
8 driving signal to synchronize the chaotic systems has been described before (L. Kocarev and
9 U. Parlitz, *General Approach for Chaotic Synchronization with Applications to*
10 *Communication*, Phys. Rev. Lett. 74, p. 5028, (June 1995)), but in the Kocarev and Parlitz
11 approach the entire chaotic drive system must be reproduced and the other subsystems contain
12 non scale-invariant nonlinearities. In the present invention, the driving function need not be
13 reproduced.

14 It should be noted that with the right choice of g , it is possible for A and B to be
15 linear. It is advantageous for communications to have A or B include some nonlinearity, as
16 this makes it harder to decode an encoded information signal and easier to separate noise from
17 the chaotic signal.

18 As a specific example, figure 3 shows a schematic diagram for a chaotic drive circuit
19 fulfilling the above conditions.

20 Drive circuit 400 comprises two interdependent subsystems A 498 and B 499 which
21 may or may not overlap in part but which together constitute the essential aspects of the

Serial No. (unassigned)
Inventor: Thomas Carroll

Patent Application
Attorney Docket No. 77,203

1 amplitude independent system of the drive. Subsystems A 498 and B 499 are not overlapping
2 in the sense that neither subsystem A 498 nor subsystem B 499 is contained within the other
3 system. Drive circuit 400 also comprises an amplitude dependent function $g(x)$, 500.

4 Drive circuit 400 comprises integrator circuits formed by differential amplifiers 411,
5 413, 415, 417, resistors 420, 421, 422, 423, 426, 427, 439, 440, 443, 444, and capacitors
6 451, 452, 453, and 454, amplitude independent nonlinear functions formed by differential
7 amplifiers 414, 416 resistors 437, 438 442 and diodes 480 and 481 and a summing circuit
8 formed by differential amplifier 412 and resistors 424 and 425. These circuits are coupled to
9 form subsystems A 498 and B 499 in the drive circuit as illustrated in figures 2 and 3. Drive
10 circuit 400, also comprises $g(x)$, the nonlinear amplitude dependent nonlinear function 500
11 (piecewise in this example), formed by differential amplifiers 510, 511, resistors 518, 519 520
12 521, 522, 523, 524, 525 and diodes 580 and 581. Component values for the resistors and
13 capacitors which were used are set fourth in the following table:

14
15
16
17
18
19
20
21

R420 = 1M Ω	R421 = 68k
R422 = 2M	R423 = 1M
R424 = 20k	R425 = 10k
R426 = 100k	R427 = 680k
R438 = 5k	R439 = 100k
R440 = 100k	R441 = 2.2k
R442 = 10k	R443 = 10k
R444 = 10k	R518 = 20k
R519 = 10k	R520 = 10k
R521 = 10k	R522 = 10k
R523 = 150k	R524 = 150k
R525 = 33k	

C451 = 0.001 μ F	C452 = 0.001 μ
C453 = 0.001 μ	C454 = 0.001 μ

P461 = 30k set to 22.5k
P462 = 200k break/ g2 @ 0.0V
P463 = 200k break/ g3 @ 0.0V

Resistance values are expressed in Ohms and capacitance values are expressed in Farads.

Drive circuit 400 can be subdivided into three subsystems A 498, B 499 and g(x) 500. Although the illustrative subsystems g(x) 500, A 498 and B 499 shown in figure 2 correspond to the two circuits forming drive circuit 400 its is not necessary, and the division of a given drive circuit 400 into subsystems in order to determine the proper configuration for a synchronized response circuit 600 is made in accordance with the analysis described herein.

The nonlinear folding function is $g_1(y)$, while the amplitude(scale)-invariant nonlinearities are provided by functions $g_2(x)$ and $g_3(y)$. The equations describing the circuit are:

1

(6)

$$\frac{dx}{dt} = -\alpha (0.05x + 0.05g_1(y) + 1.47z + 0.1S_1)$$

$$\frac{dy}{dt} = -\alpha (-0.5x - 0.44g_1(y) + 0.147y)$$

$$\frac{dz}{dt} = -\alpha (-0.5g_2(x) + z - 0.5w)$$

$$\frac{dw}{dt} = -\alpha (-10.0g_3(g_1(y)) + 10.0w)$$

$$g_1(y) : \left[\begin{array}{ll} y \leq -1.6 & g_1 = -2.5y - 7.2 \\ -1.6 < y < 1.6 & g_1 = 2.0y \\ 1.6 \leq y & g_1 = -2.5y + 7.2 \end{array} \right]$$

$$g_3(y) : \left[\begin{array}{ll} y \leq 0 & g_3 = 4.5y \\ y > 0 & g_3 = 0 \end{array} \right]$$

$$g_2(x) : \left[\begin{array}{ll} x \leq 0 & g_2 = 0 \\ x > 0 & g_2 = 4.5x \end{array} \right]$$

2 where the time factor α was 10^4 .

3 The plots of functions $g_1(y)$, $g_2(x)$ and $g_3(y)$ as defined in figure 3 and equation (6),
4 are illustrated in figures 4a, 4b, and 4c, respectively. These plots reflect the driving of the
5 above nonlinear functions with a 10Hz sine wave. S_1 is a non-zero information signal,
6 injected into drive circuit 400 when the circuits are used for communications. The presence

Serial No. (unassigned)

Inventor: Thomas Carroll...

Patent Application

Attorney Docket No. 77,203

1 of chaos in drive circuit 400 is confirmed by calculating the largest Lyapunov exponent
2 numerically from eqs. (6). This exponent is 765 s^{-1} . Conventional methods for calculating
3 Lyapunov exponents, as analytical measurement, numerical and otherwise can be used, such
4 as, for example those described by Eckmann et al., *Rev. Mod. Phys.*, Vol. 57, p.617 et seq.
5 (1985); Lichtenberg et al., *Regular and Stochastic Motion*, Springer-Verlag, New York
6 (1983); Rashband, *Chaotic Dynamics of Nonlinear Systems*, John Wiley & Sons, New York
7 (1990); and Wolf et al., *Physica*. Vol. 16D, p. 285 et seq.(1985).

8 The chaotic attractor for example drive circuit 400, produced by plotting the y signal
9 vs. the x signal is shown in Figure 5.

10 Referring now to figure 6, which shows an example of a chaotic response circuit 600
11 built to synchronize with drive circuit 400 of figure 3, comprises duplicates of subsystems A
12 498 and B 499 of drive circuit 400, labeled as subsystems A' 698 and B' 699.

13 Response circuit 600 comprises integrator circuits formed by differential amplifiers
14 611, 613, 615, 617, resistors 620, 621, 622, 623, 626, 627, 639, 640, 643, 644, and
15 capacitors 651, 652, 653, and 654, amplitude independent nonlinear functions formed by
16 differential amplifiers 614, 616 resistors 637, 638, 642 and diodes 680 and 681 and a
17 summing circuit formed by differential amplifier 612 and resistors 624 and 625. These
18 circuits are coupled to form subsystems A' 698 and B' 699 in response circuit 600 as
19 illustrated in figures 2 and 6. The reader should note that $g(x)$, the amplitude dependent
20 nonlinear circuit 500, is not reproduced in response circuit 600. Component values for the
21 resistors and capacitors which were used are set fourth in the following table:

Serial No. (unassigned)
Inventor: Thomas Carroll

Patent Application
Attorney Docket No. 77,203

1
2
3
4
5
6
7
8
9
10
11
12
13
14
15
16
17
18
19

R621 = 68k Ω	R622 = 2M
R623 = 1M	R624 = 20k
R625 = 10k	R626 = 100k
R627 = 680k	R638 = 5k
R639 = 100k	R640 = 100k
R641 = 2.2k	R642 = 10k
R643 = 10k	R644 = 10k
C651 = 0.001 μ F	C652 = 0.001 μ
C653 = 0.001 μ	C654 = 0.001 μ
P661 = 30k set to 22.5k	
P662 = 200k break/ g2 @ 0.0V	
P663 = 200k break/ g3 @ 0.0V	

Resistance values are expressed in Ohms and capacitance values are expressed in Farads.

Response circuit 600 can be subdivided into two subsystems A' 698 and B' 699. Although the illustrative subsystems A' 698 and B' 699 shown in figure 2 correspond to the two circuits forming response circuit 600, its is not necessary, and the division of a given response circuit 600 into subsystems in order to determine the proper configuration for synchronization with a drive circuit 400 is made in accordance with the analysis described herein.

The equations describing the circuit are:

(7)

$$u_d = \Gamma g_1(y)$$

$$\frac{dx'}{dt} = -\alpha (0.05x' + 0.05u + 1.47z')$$

$$\frac{dy'}{dt} = -\alpha (-0.5x' - 0.44u + 1.47y')$$

$$\frac{dz'}{dt} = -\alpha (-0.5g_2(x') + z - 0.5w')$$

$$\frac{dw'}{dt} = -\alpha (-10.0g_3(u) + 10.0w')$$

1

2 The output function $g_1(y)$ has been rescaled by a factor Γ to produce the driving
3 variable u_d . The largest Lyapunov for the response circuit is calculated numerically to be
4 $-1470.0s^{-1}$, independent of the scaling factor Γ .

5 It is necessary for $u_d = \Gamma g_1(y)$ to have a known relation to y' at some known value of
6 y in order to detect synchronization of the drive 400 and response 600 circuits. This
7 relationship must be independent of the scaling factor Γ . In the example circuit above this
8 relation is satisfied by $\Gamma g_1(0) = 0$. Referring now to figure 10, which is a graph of y' vs the
9 transmitted signal u_d when the scaling factor is $\Gamma=1$, the reader should note that for all values
10 of Γ , the graph passes through the origin $(0,0)$. This allows synchronization to be confirmed
11 by sampling the value of the transmitted signal u_d when y' crosses 0. When the circuits are in
12 synchronization, the sampled value is 0.

1 Among the many embodiments of the present invention, AISN may be employed to
2 transmit information on a chaotic carrier in the form of data encoded on a pure frequency
3 signal. The system allows the transmission of the data by a means which is insensitive to
4 fading distortion and not very sensitive to other types of noise. Referring to figures 2, 3, 6,
5 and 13 example chaotic drive circuit 400, forms a portion of a transmitter 800 and example
6 chaotic response circuit 600 forms part of a receiver 900. Drive circuit 400 is injected with
7 an information signal S_I . Assume, for purposes of example, the signal S_I is configured as
8 $2.0\sin(2\pi f_1 t)$ where f_1 is less than 200Hz. The frequencies which contain much of the power
9 for the transmitted signal approach 2kHz, so the S_I frequency is small in comparison to
10 maximize the S/N ratio in receiver 900. Frequencies above 200Hz for S_I would tend to lower
11 the S/N ratio in this example. The effects of different types of signal encoding are system
12 dependent; for the circuit described in figure 3 and equation (6), the fact that different types
13 of signal encoding move the plot (see figure 10) of y' vs u_d in different directions may be
14 used for sending multiple information signals on one chaotic signal.

15 Referring again to figure 3, the information signal S_I is injected into the integrator
16 whose output voltage is labeled as X. The drive signal u_d may be transmitted to response
17 circuit 600 by any desired conventional wired or wireless fashion, 11. The information signal
18 is decoded from the chaotic carrier u_d by comparing u_d to response 600 output y' as y' crosses
19 0. In order to detect the information in the chaotic carrier signal u_d , the negative-going
20 zero crossings of the signal y' from the response circuit is used to strobe u_d , generating a
21 detected signal Δ . When drive 400 and response 600 circuits are synchronized, u_d is zero

1 when y' is zero, therefore Δ is zero. When response 600 and drive 400 are not synchronized,
2 u_d is nonzero when y' crosses zero, so Δ is non-zero. Generally, for a small signal S_i injected
3 into the drive 400 system (or if any parameter is changed by a small amount), the average of
4 Δ is proportional to the injected signal (or the parameter difference between the drive and
5 response system). If S_i has a much lower frequency than the average rate at which y' crossed
6 zero, Δ can also be used to detect S_i , since the information signal S_i , causes a lack of
7 synchronization. Passing Δ through a low pass filter (not shown) has the effect of averaging Δ
8 to reveal the information signal S_i .

9 Detector circuit 900, shown in figure 11, may be used to decode the information
10 signal. The signal y' is greatly amplified and applied to a comparator 960 so that a pulse is
11 generated when y' crosses 0 in the negative direction. This pulse is applied to a sample and
12 hold amplifier 950 which samples the difference between y' and u_d when y' crosses 0. The
13 output of the sample and hold amplifier 900 is the detected signal. Figure 12 shows the low
14 frequency power spectrum of the transmitted signal u_d when the informational signal f_1 is 30
15 Hz. The signal to noise ratio at f_1 was calculated by subtracting the average signal power (in
16 dB) within 2 Hz of f_1 (not including the power at f_1) from the power at f_1 . Figure 7 displays
17 a plot of the power spectrum of the transmitted signal u_d , which shows the broad band nature
18 of chaos. Figure 8(a) shows a plot of the y' signal vs. y when $\Gamma=1$, showing synchronization.
19 In figure 8(b) also shows a plot of the y' signal vs. y however in 8(b) $\Gamma=0.2$. The signal y' is
20 now a scaled version of y . Figure 9 shows y' vs. x' in the response circuit when $\Gamma=0.5$. The
21 plot of figure 9 is a scaled reproduction of the attractor in figure 5.

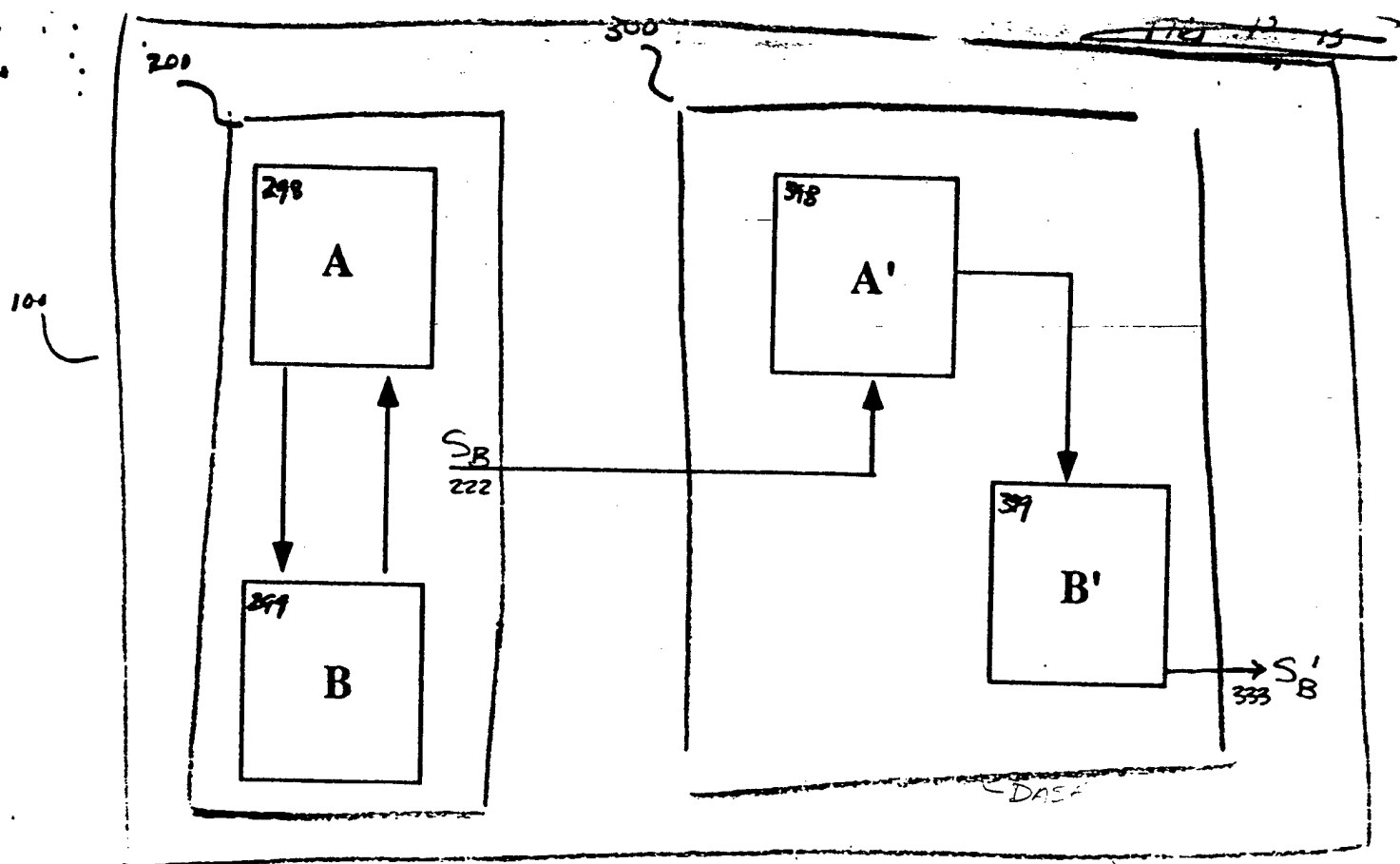

Figure 1

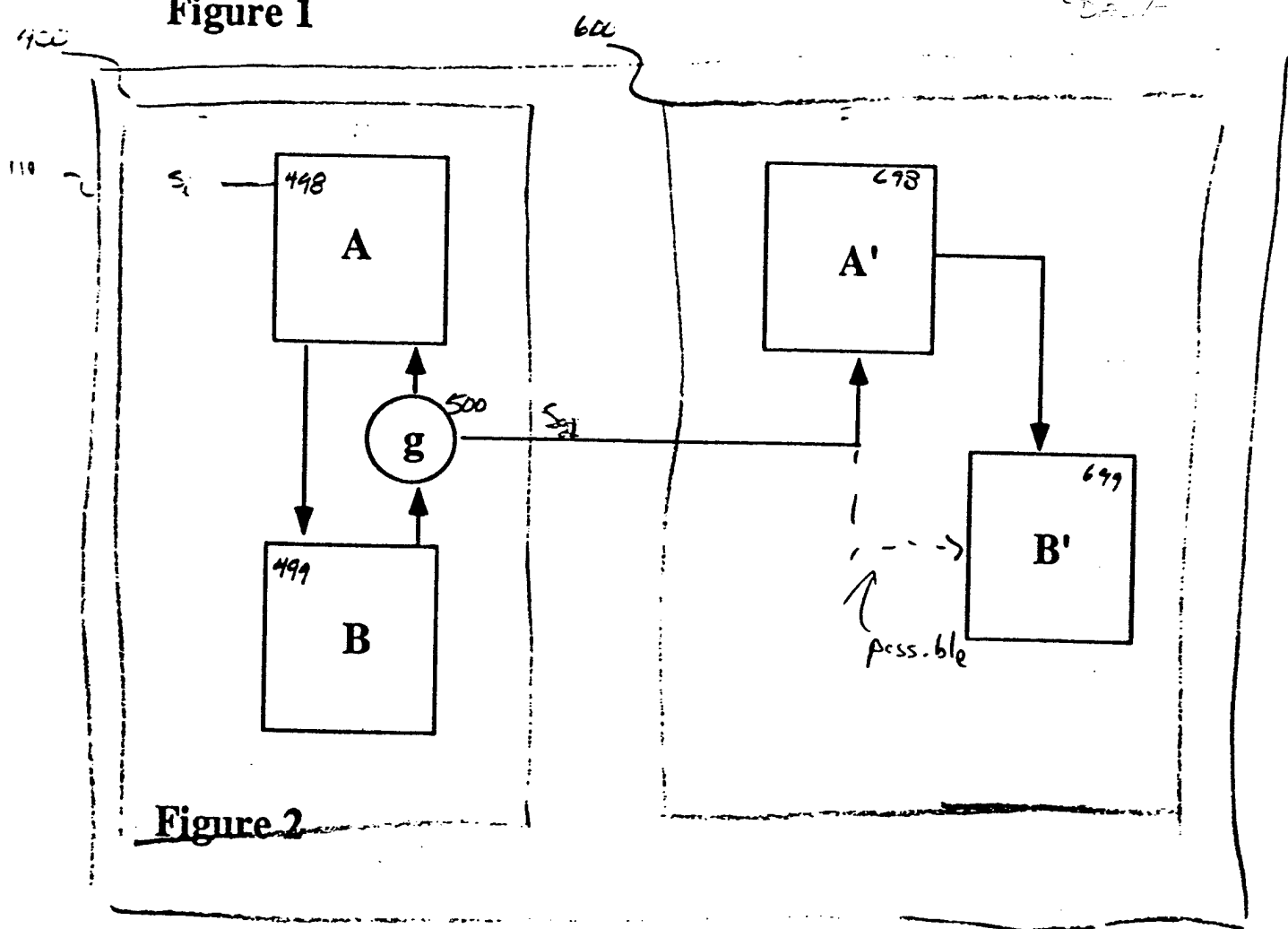

Figure 2

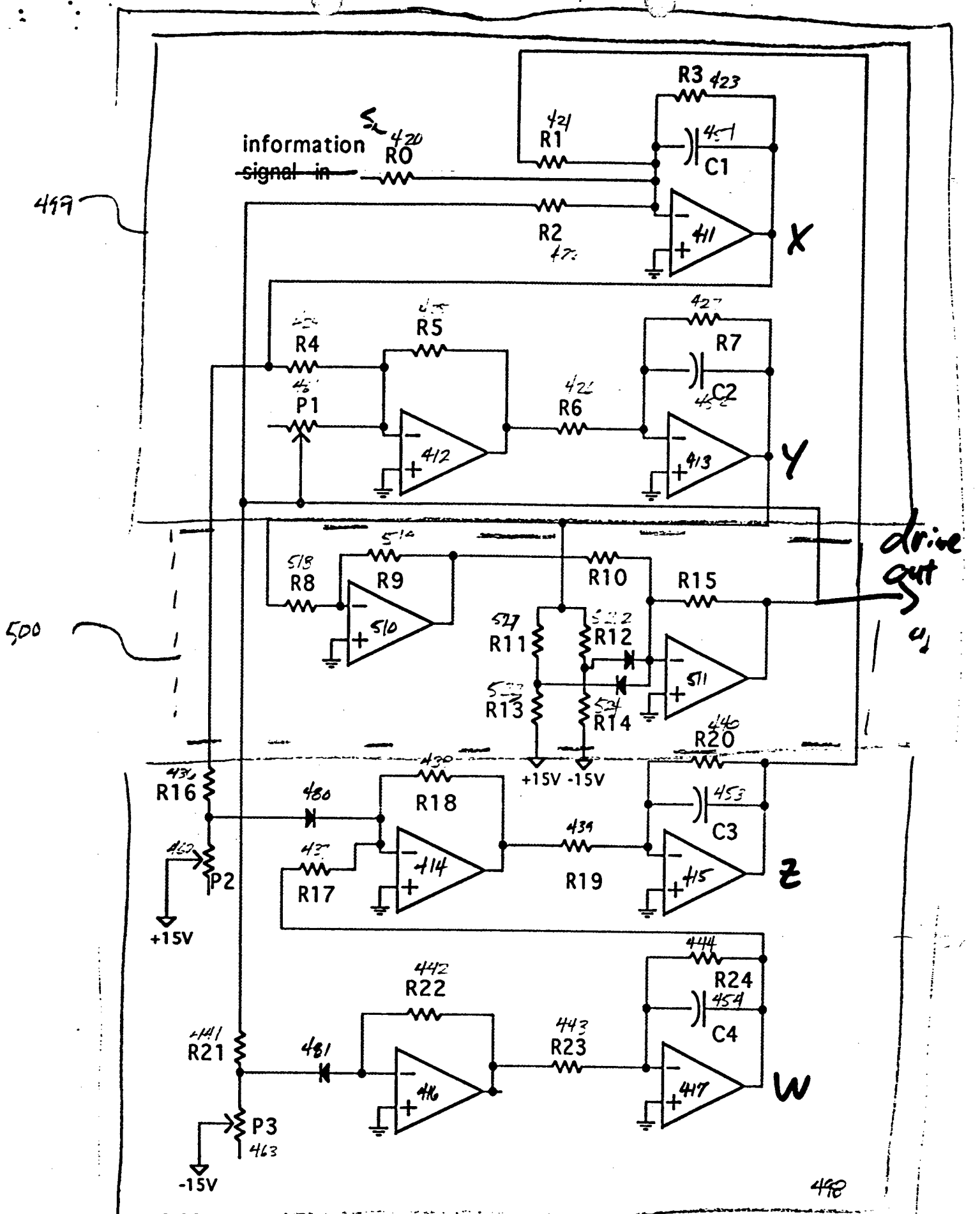
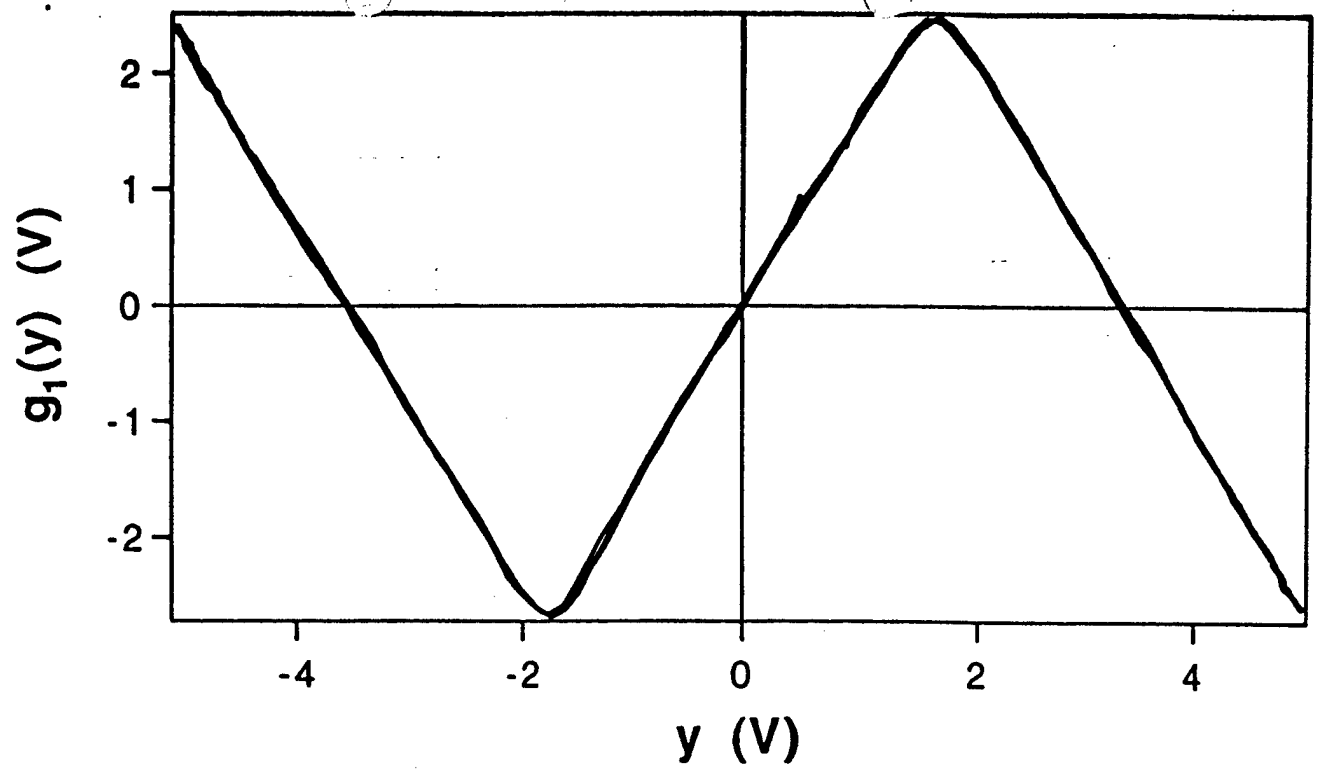
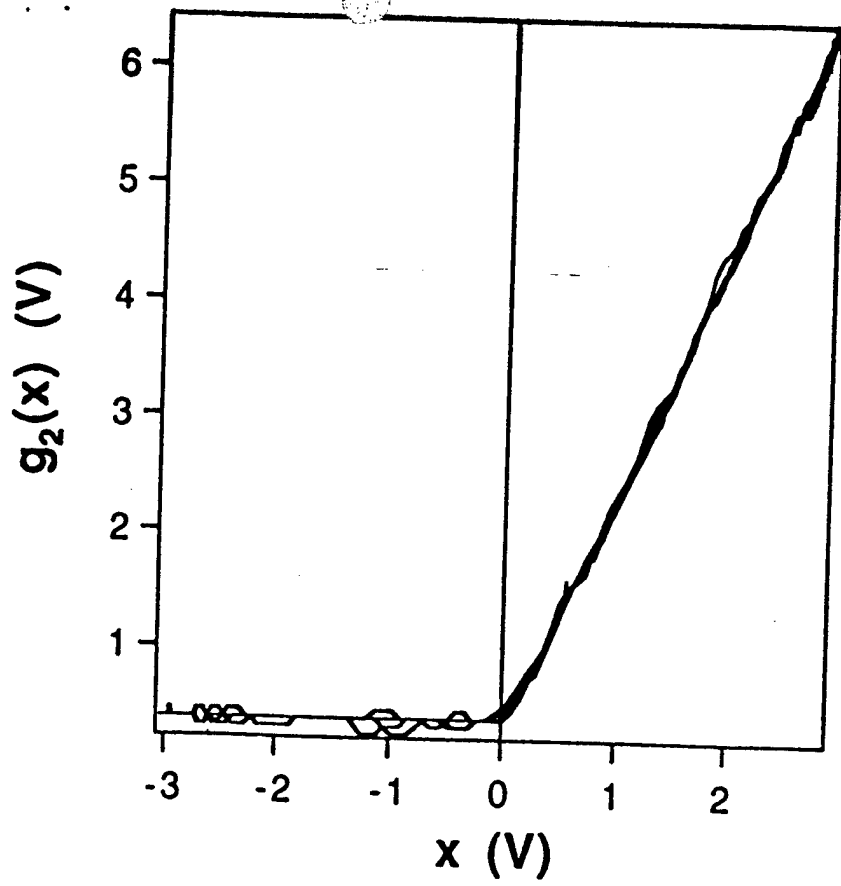

Figure 3



⊙

F.5 4 a



⊙

Fig 4b

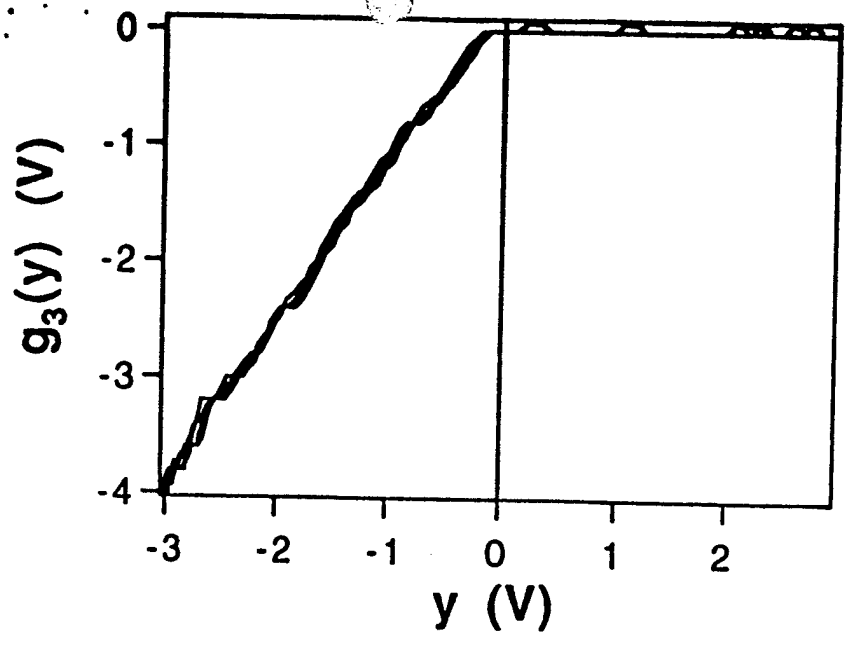
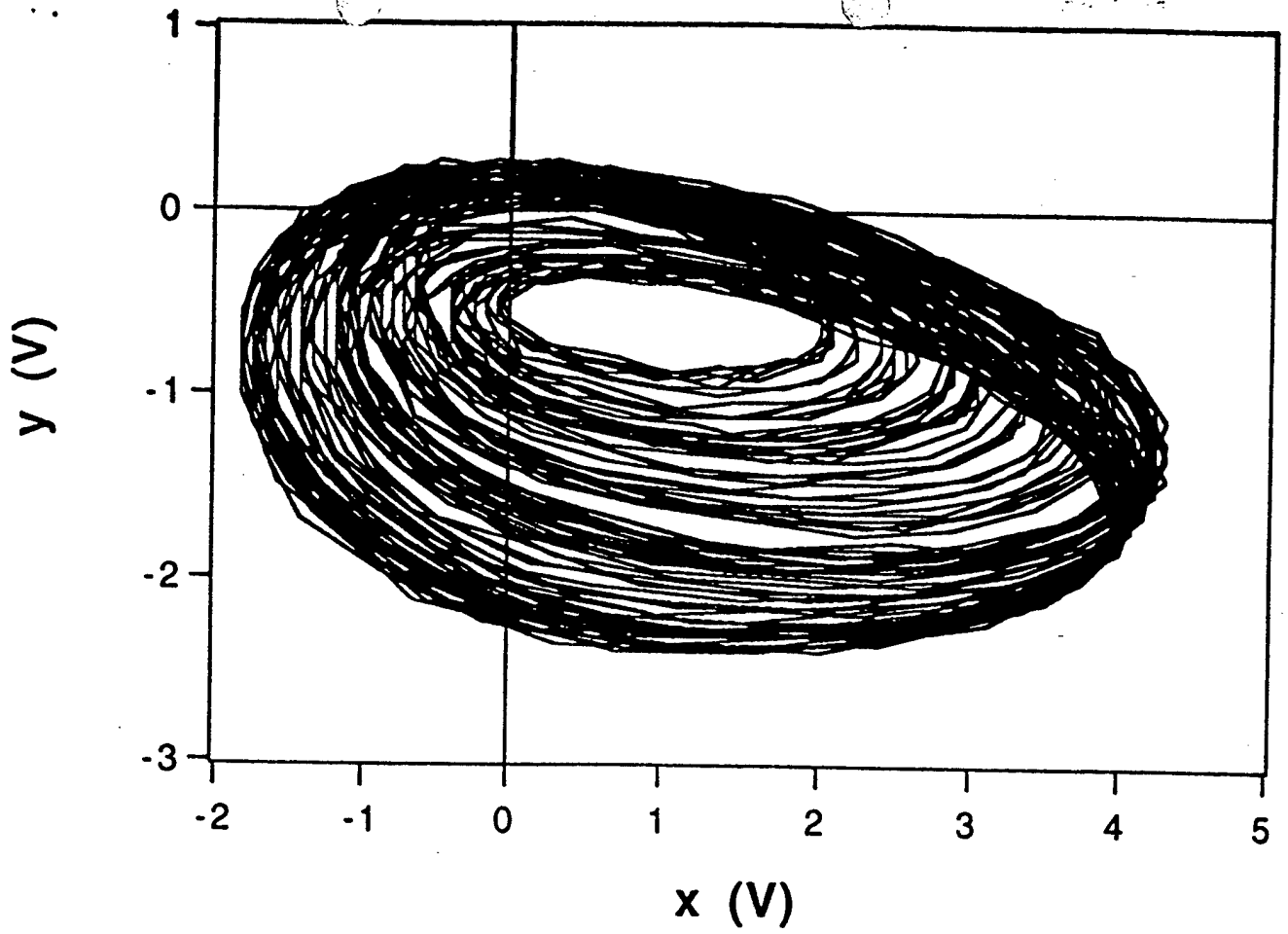

Fig 4c



699

drive
signal
in

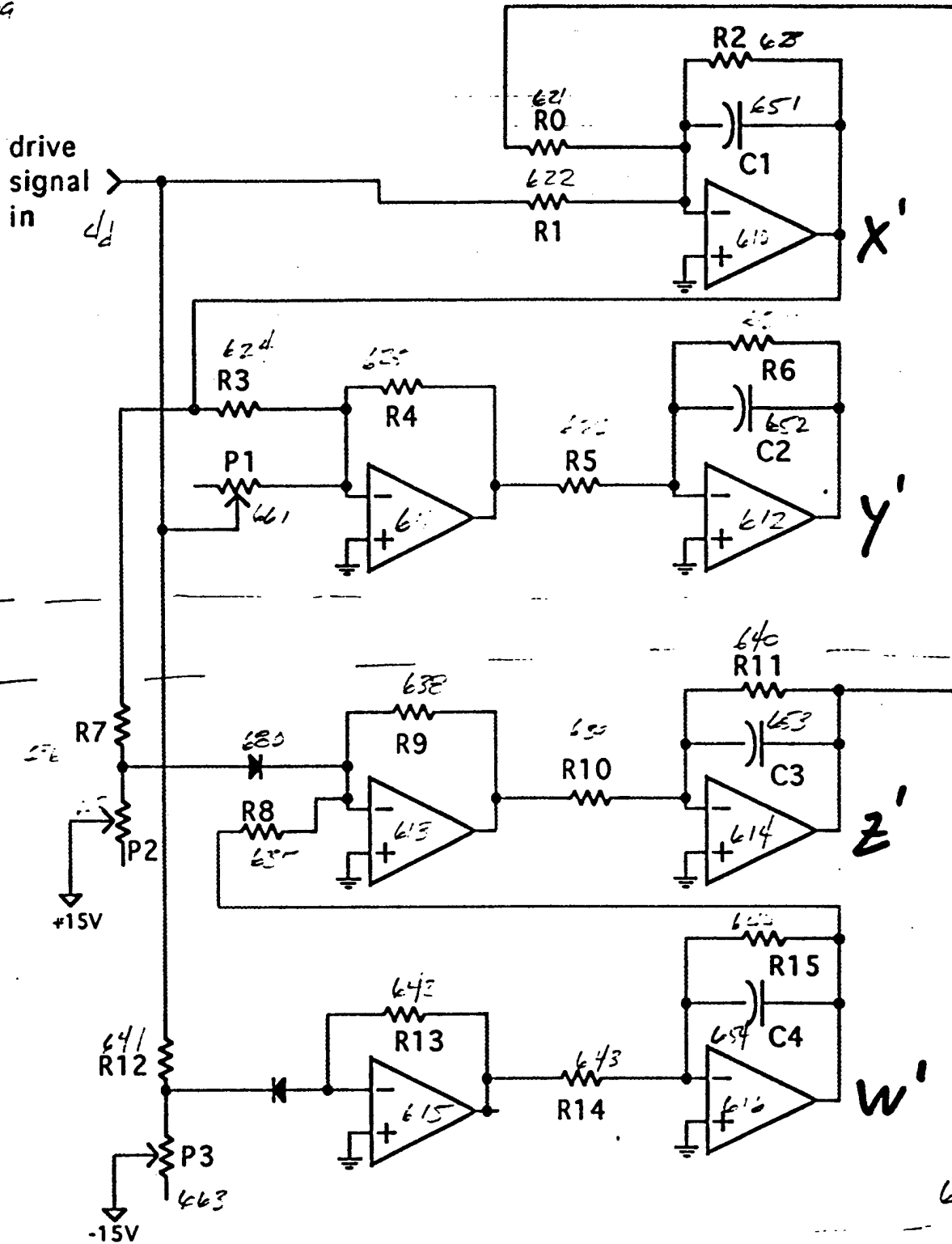
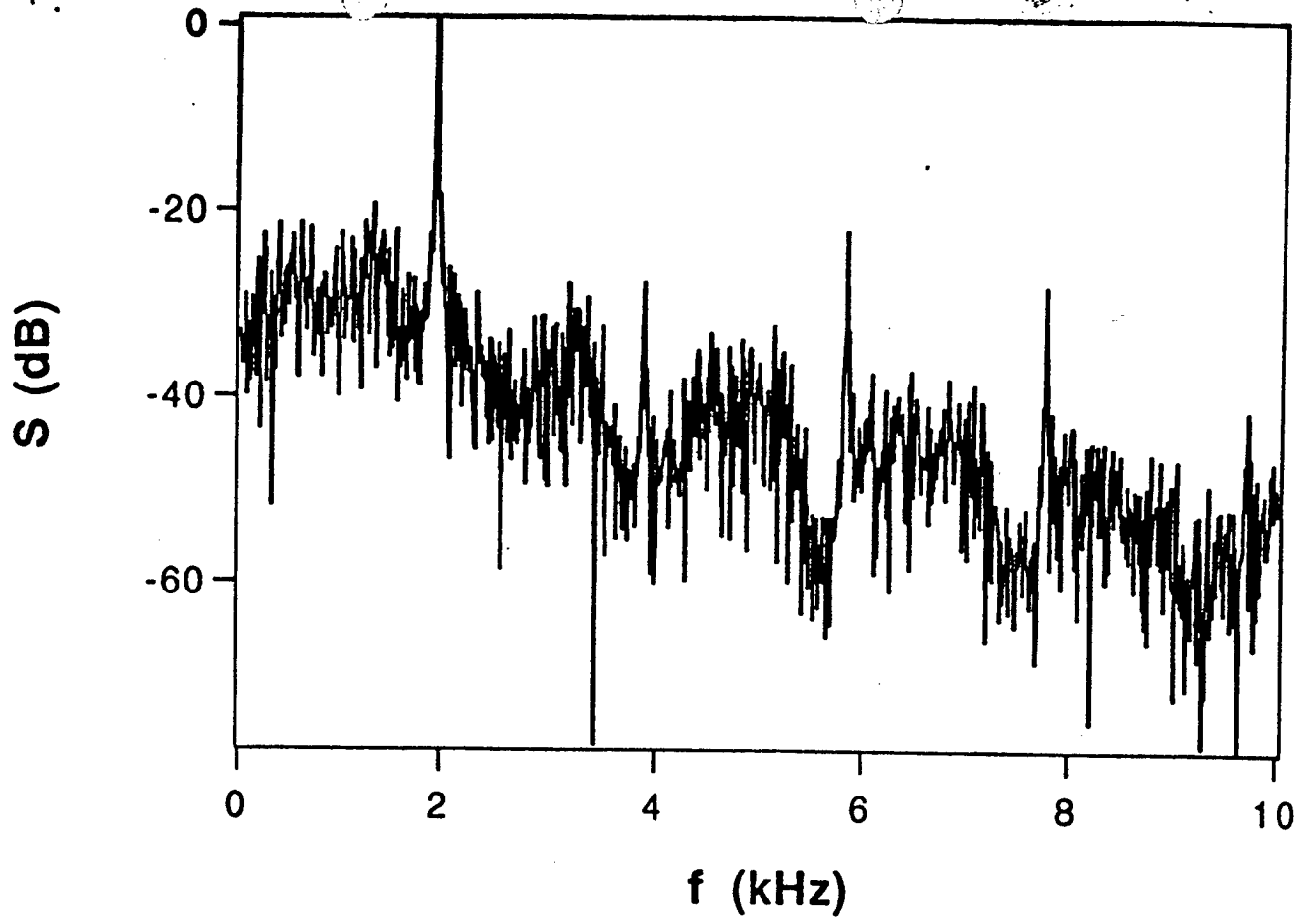
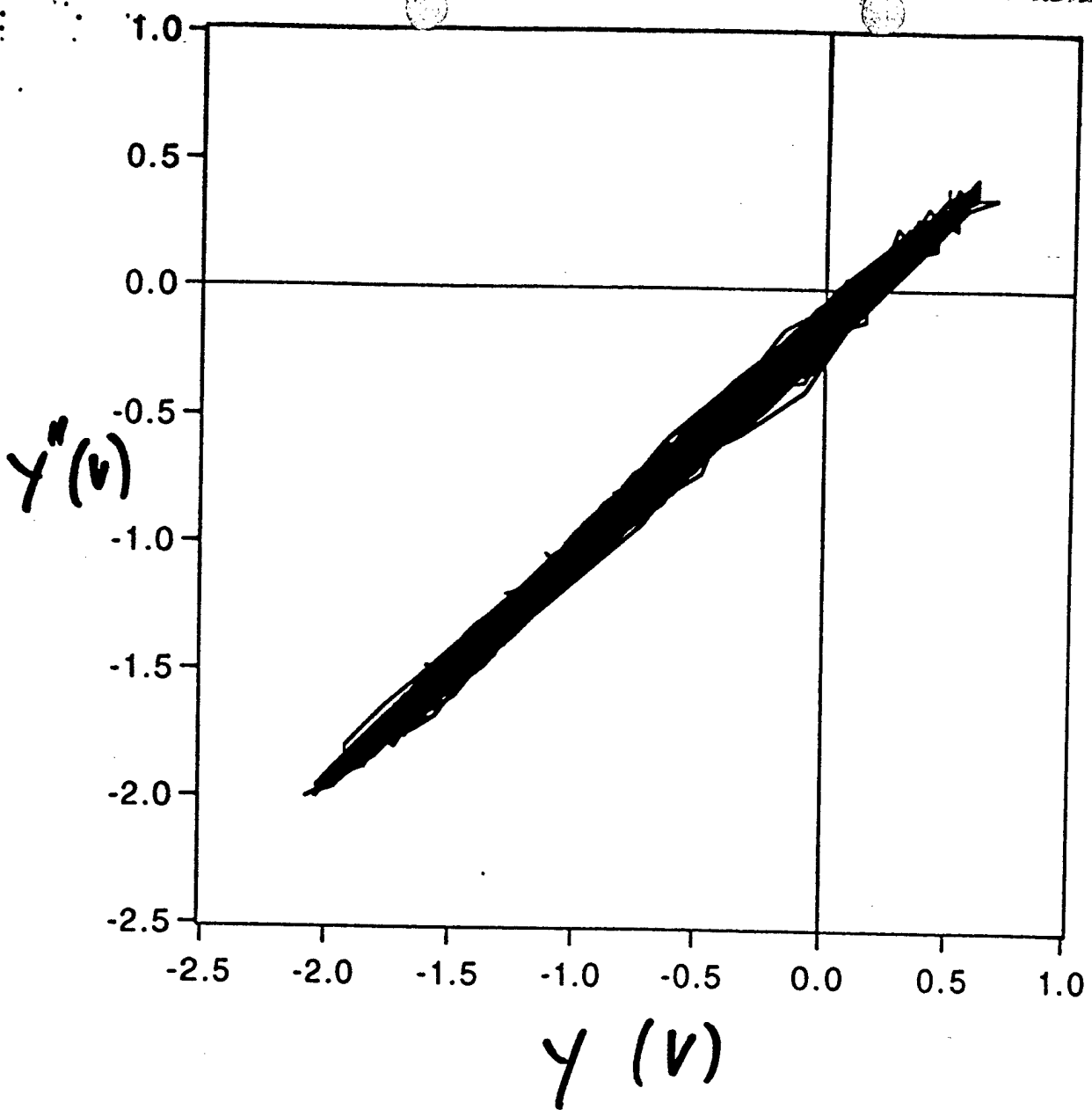

Fig 6





oo

Fig 8(a)

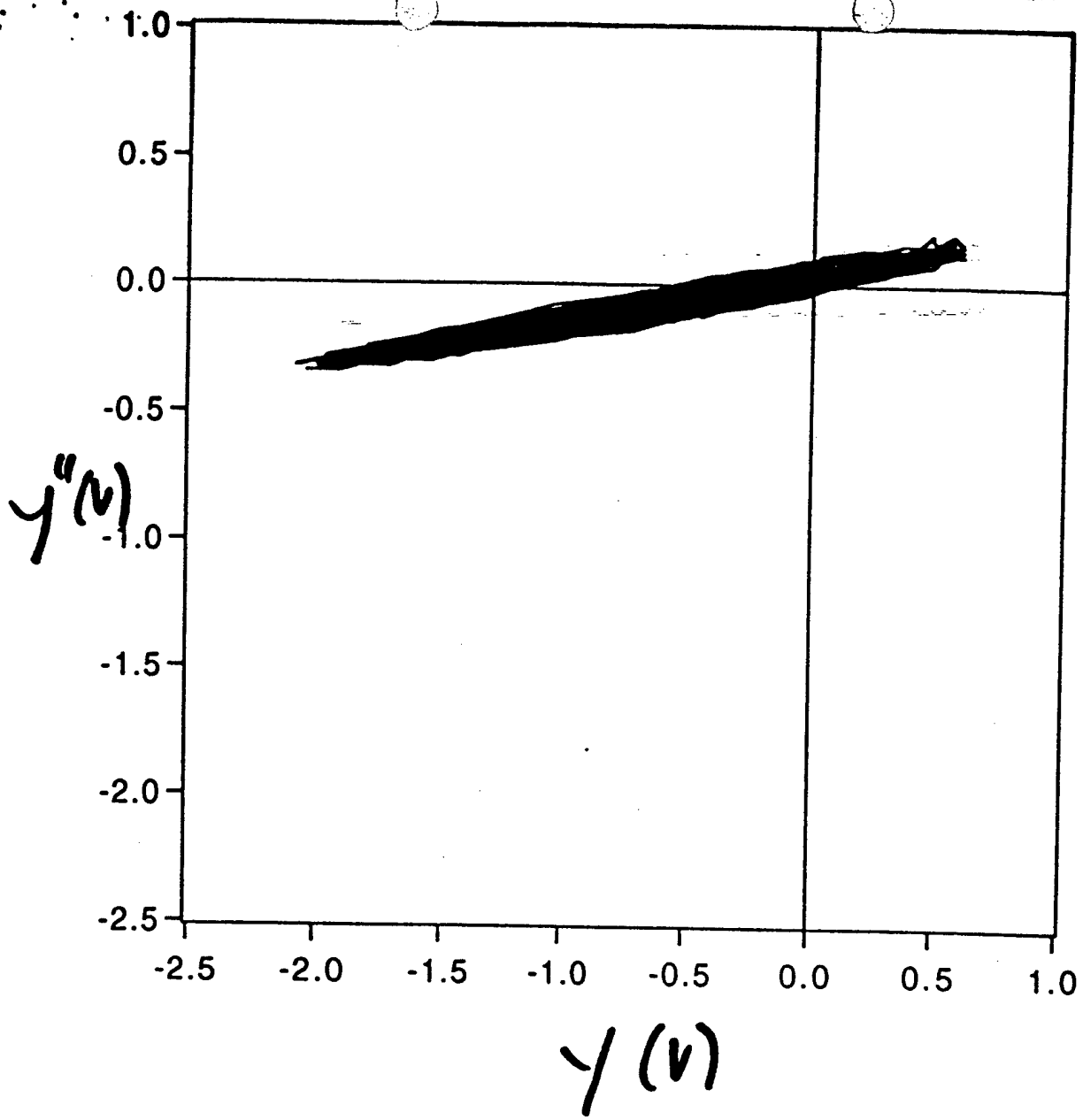
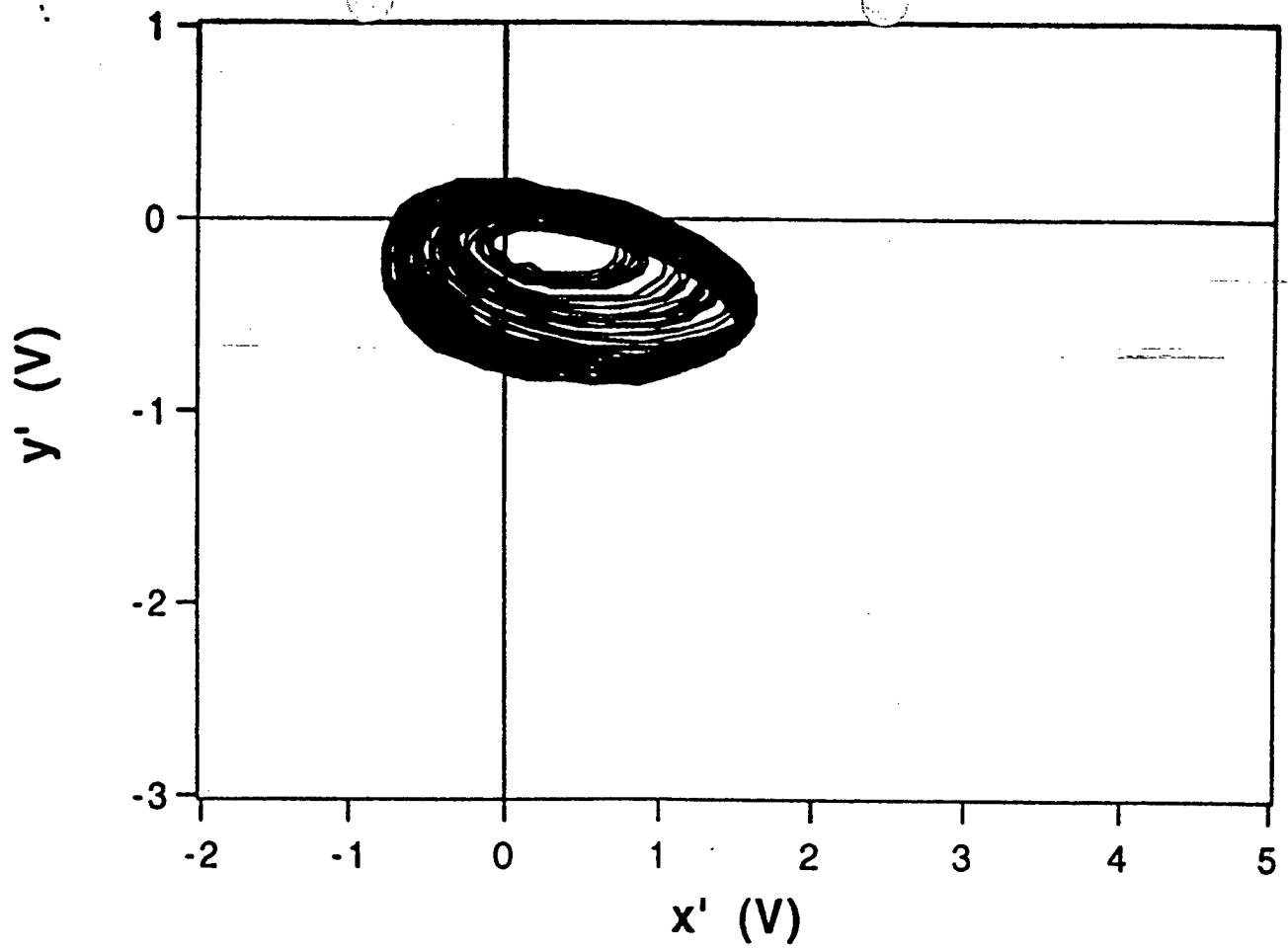

Fig 8(b)



oo

Fig 9

~~y~~
y

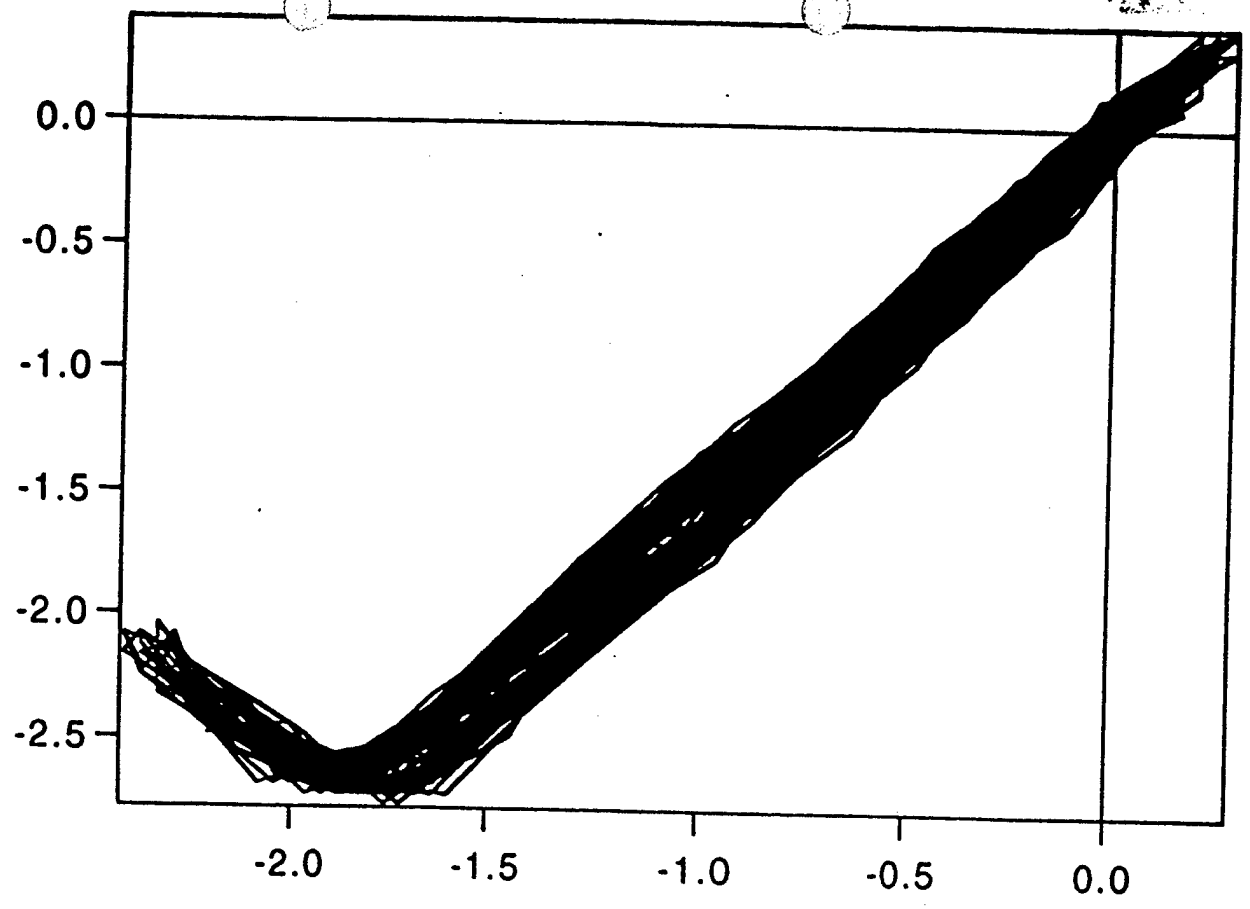

~~y~~(v)
 $Asi(y) = u$

oo

Fig 10

900
~~900~~

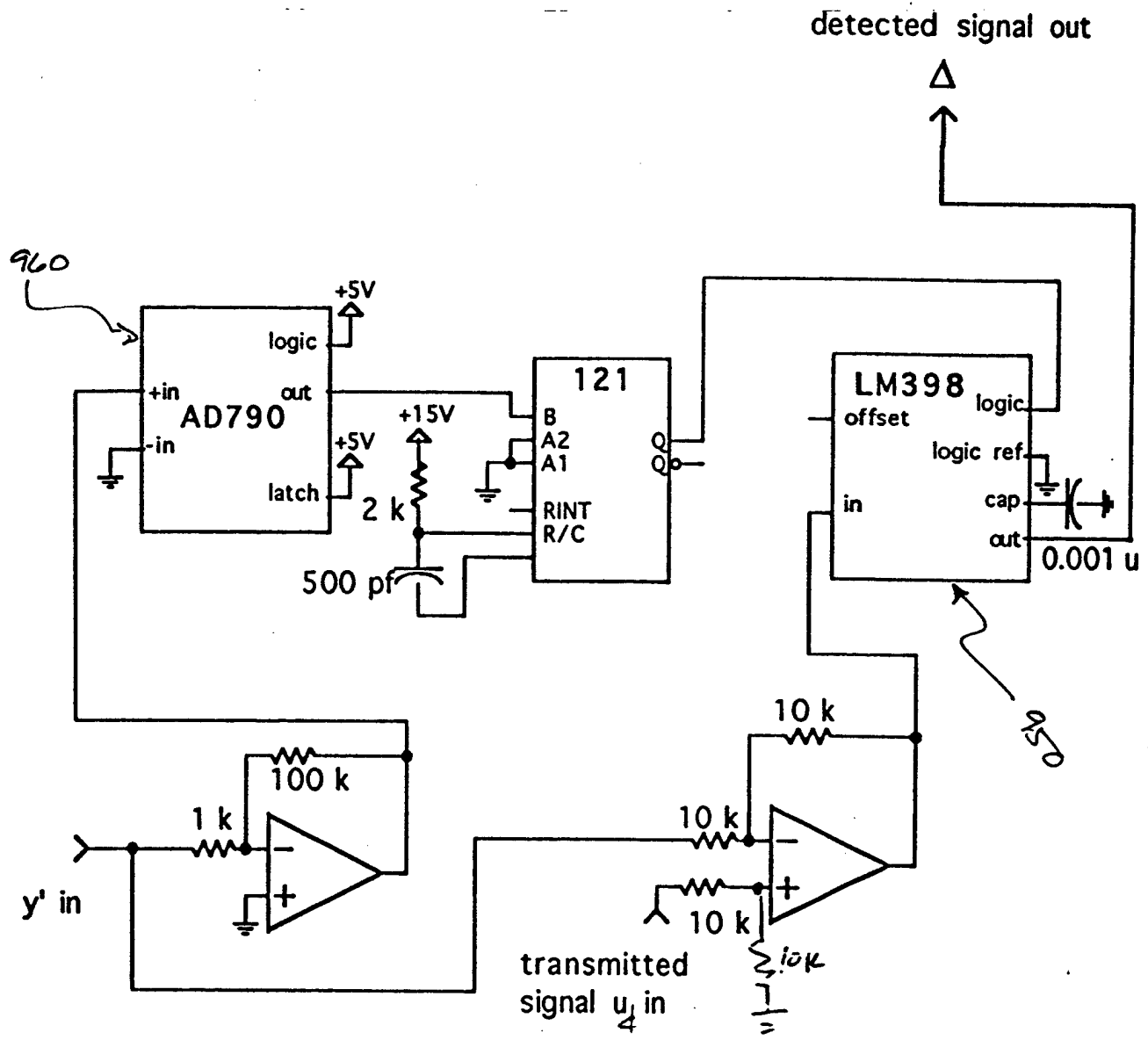

Fig 11

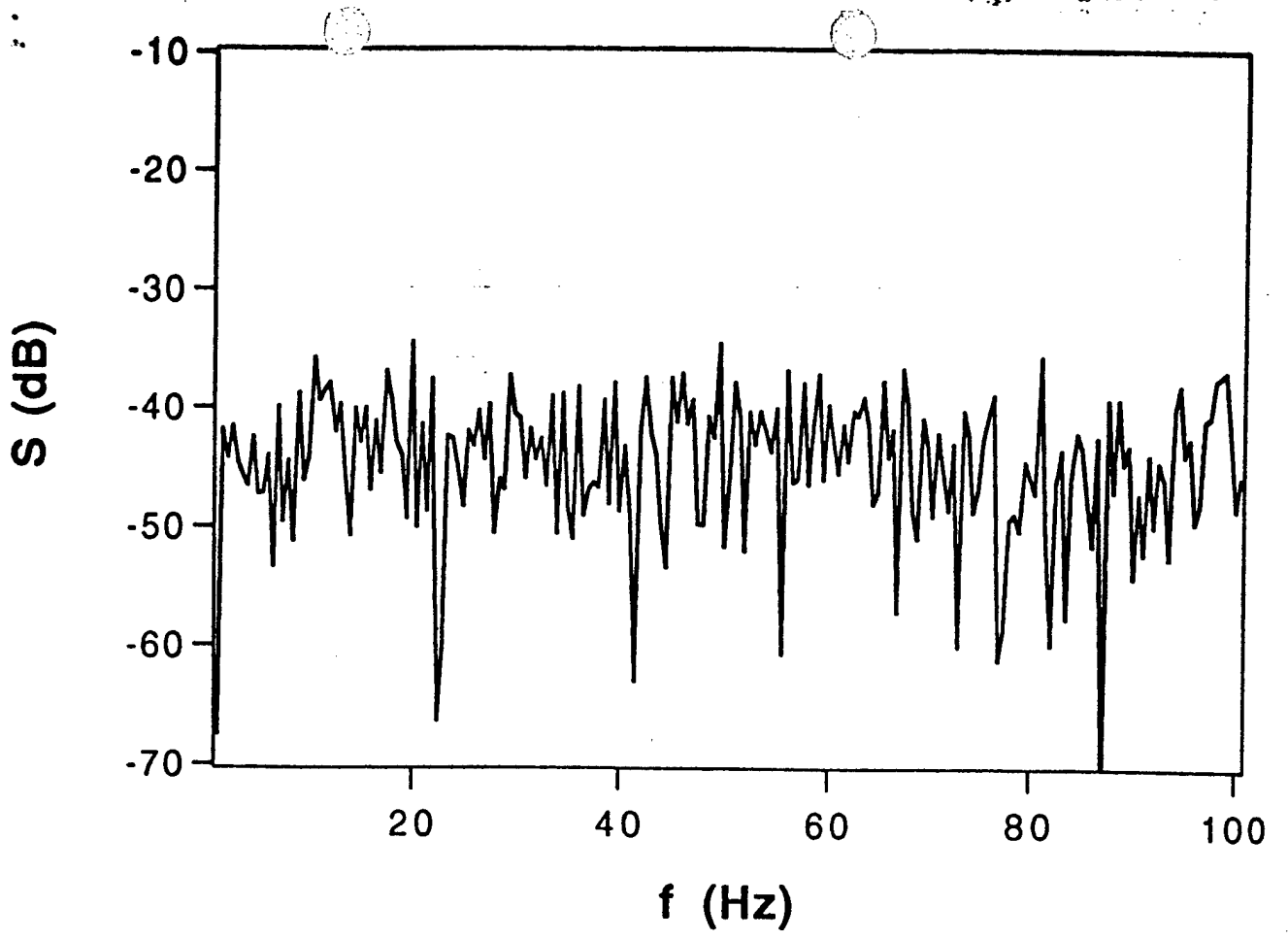

Fig 12

