

REPORT DOCUMENTATION PAGE

AFRL-SR-BL-TR-00-

0687

Public reporting burden for this collection of information is estimated to average 1 hour per response, including the time for gathering and maintaining the data needed, and completing and reviewing the collection of information. Send comments and suggestions for reducing this burden to Washington Headquarters Service, Directorate for Information Operations and Reports, 1215 Jefferson Davis Highway, Suite 1204, Arlington, VA 22202-4302, and to the Office of Management and Budget, Paperwork Reduction Project (0704-0188) Washington, DC 20503.
PLEASE DO NOT RETURN YOUR FORM TO THE ABOVE ADDRESS.

1. REPORT DATE (DD-MM-YYYY) xx-09-2000		2. REPORT DATE Final		3. DATES COVERED (From - To) Nov 1997 - Sept 2000	
4. TITLE AND SUBTITLE Manganese Doped YAlO ₃ as a Multi-Use Material for Holographic Recording, Holographic-Sensing, Optical Storage and Lasers				5a. CONTRACT NUMBER F49620-98-1-0101	
				5b. GRANT NUMBER F49620-98-1-0101	
				5c. PROGRAM ELEMENT NUMBER N/A	
				5d. PROJECT NUMBER N/A	
				5e. TASK NUMBER N/A	
				5f. WORK UNIT NUMBER N/A	
6. AUTHOR(S) Loutts, George B. Noginov, Mikhail A.				8. PERFORMING ORGANIZATION REPORT NUMBER N/A	
7. PERFORMING ORGANIZATION NAME(S) AND ADDRESS(ES) Norfolk State University 700 Park Avenue Norfolk, VA 23504				10. SPONSOR/MONITOR'S ACRONYM(S) AFOSR/NE	
9. SPONSORING/MONITORING AGENCY NAME(S) AND ADDRESS(ES) AFOSR 801 N. Randolph St. Room 732 Arlington, VA 22203-1977				11. SPONSORING/MONITORING AGENCY REPORT NUMBER N/A	
12. DISTRIBUTION AVAILABILITY STATEMENT Approved for public release, distribution unlimited N/A					
13. SUPPLEMENTARY NOTES N/A					
14. ABSTRACT High quality single crystals of manganese doped yttrium orthoaluminate, Mn:YA10 ₃ , and its analogs have been grown by the Czochraski technique. The crystals have been characterized by chemical analysis, x-ray diffractometry, optical spectroscopy, electron paramagnetic resonance spectroscopy, and tested in the holographic recording experiments. Mn ²⁺ , Mn ³⁺ , and Mn ⁴⁺ ions were identified and described in as-grown crystals. The reversible photoexcitation reaction Mn ⁴⁺ = Mn ³⁺ + e and associated with it coloration and diffraction grating recording were studied in detail. The efficient diffraction grating recording was obtained in the crystals in one-color recording scheme and two-color recording scheme. Holographic recording tests of Mn:YA10 ₃ at IBM Almaden Research Center demonstrated high potential of the material for applications in optical data storage. The project generated significant interest among students and faculty at Norfolk State University, as well as in the research community, and attracted further substantial support from NSF.					
15. SUBJECT TERMS Material for holographic recording, color centers, photorefractive material, manganese doped perovskites					
16. SECURITY CLASSIFICATION OF:			17. LIMITATION OF ABSTRACT	18. NUMBER OF PAGES	19a. NAME OF RESPONSIBLE PERSON
a. REPORT	b. ABSTRACT	c. THIS PAGE			19b. TELEPHONE NUMBER (Include area code)
u	u	u	UU		

20010102 036

Form Approved
OMB No. 5000-0095
Expires Aug 31, 2001

REPORT OF INVENTIONS AND SUBCONTRACTS
(Pursuant to Patent Rights' Contract Clause) (See Instructions on back)

The public reporting burden for this collection of information is estimated to average 1 hour per response, including the time for reviewing instructions, searching existing data sources, gathering and maintaining the data needed, and completing and reviewing the collection of information. Send comments regarding this burden estimate or any other aspect of this collection of information, including suggestions for reducing the burden, to Washington Headquarters Services, Directorate for Information Operations and Reports (800-4095), 1215 Jefferson Davis Highway, Suite 1204, Arlington, VA 22202-4302. Respondents should be aware that notwithstanding any other provision of law, no person shall be subject to a collection of information if it does not display a currently valid OMB control number.

PLEASE DO NOT RETURN YOUR COMPLETED FORM TO THIS ADDRESS. RETURN COMPLETED FORM TO THE CONTRACTING OFFICER.

1. NAME OF CONTRACTOR/SUBCONTRACTOR		2. TYPE OF REPORT (X one)	
Norfolk State University		a. INTERIM <input type="checkbox"/> b. FINAL <input checked="" type="checkbox"/>	
700 Park Avenue Norfolk, VA 23504		3. CONTRACT NUMBER	
7. ADDRESS (include ZIP Code)		F49620-98-1-0101	
8. AWARD DATE (YYYYMMDD)		9. AWARD DATE (YYYYMMDD)	
1997-11-1		1997-11-1	
10. AWARD NUMBER		11. TO 2000-04-30	

SECTION I - SUBJECT INVENTIONS

1. NAME(S) OF INVENTOR(S) (Last, First, Middle Initial)	2. TITLE OF INVENTION(S)	3. DISCLOSURE NUMBER, PATENT APPLICATION SERIAL NUMBER OR PATENT NUMBER	4. ELECTION TO FILE PATENT APPLICATIONS (X)				5. CONFIRMATORY INSTRUMENT OR ASSIGNMENT FORWARDED TO CONTRACTING OFFICER (X)
			(1) UNITED STATES	(2) FOREIGN	(a) YES	(b) NO	
Loutts, Georgii, B. Noginov, Mikhail, A. Ries, Heidi, R.	Manganese-doped aluminate crystals for holographic recording and optical data storage	Application No. 09/249,158	X				X

SECTION II - SUBCONTRACTS (Containing a "Patent Rights" clause)

6. NAME OF SUBCONTRACTOR(S)	7. ADDRESS (include ZIP Code)	8. SUBCONTRACT NUMBER(S)	9. FAR "PATENT RIGHTS" (X one)		10. DESCRIPTION OF WORK TO BE PERFORMED UNDER SUBCONTRACT(S)	11. SUBCONTRACT DATES (YYYYMMDD)	
			(1) CLAUSE NUMBER	(2) DATE (YYYYMM)		(1) AWARD	(2) ESTIMATED COMPLETION
NONE							

SECTION III - CERTIFICATION

12. CERTIFICATION OF REPORT BY CONTRACTOR/SUBCONTRACTOR (Required if applicable)	13. SMALL BUSINESS or NONPROFIT ORGANIZATION
I certify that the reporting party has procedures for prompt identification and timely disclosure of "Subject Inventions," that such procedures have been followed and that all "Subject Inventions" have been reported.	
14. NAME OF AUTHORIZED CONTRACTOR/SUBCONTRACTOR OFFICIAL (Last, First, Middle Initial)	15. DATE SIGNED
N/A	

DOD PROPERTY IN THE CUSTODY OF CONTRACTORS

(DFARS 245.505-14)

(See instructions on reverse before completing form)

REPORT AS OF
30 SEP 19____
OR

*Form Approved
OMB No. 0704-0246
Expires Dec 13, 1996*

REPORT CONTROL SYMBOL

Public reporting burden for this collection of information is estimated to average 1 hour per response, including the time for reviewing instructions, searching existing data sources, gathering and maintaining the data needed, and completing and reviewing the collection of information. Send comments regarding this burden estimate or any other aspect of this collected information, including suggestions for reducing this burden, Washington Headquarters Services, Directorate for Information Operations and Reports, 1215 Jefferson Davis Highway, Suite 1204, Arlington, VA 22202-4302, and to the Office of Management and Budget, Paperwork Reduction Project (0704-0246) Washington, DC 20503.

**PLEASE DO NOT RETURN YOUR COMPLETED FORM TO EITHER OF THESE ADDRESSES.
RETURN COMPLETED FORM TO THE ADDRESS IN ITEM 1.**

1. TO <i>(Enter name and address of property administrator)</i>	2. FROM <i>(Enter full name, address and CAGE code of contractor)</i>
N/A	

3. IF GOVERNMENT - OWNED, CONTRACTOR - OPERATED PLANT, ENTER GOVERNMENT NAME OF PLANT

4. CONTRACT NO. <i>(PINN)</i>	5. CONTRACT PURPOSE	6. BUSINESS TYPE <i>(L, S, or N)</i>	7. OFFICIAL NAME OF PARENT COMPANY
-------------------------------	---------------------	--------------------------------------	------------------------------------

8. PROPERTY LOCATION(S)	9. PLANT EQUIPMENT PACKAGE <i>(PEP No. and use)</i>
-------------------------	---

a. PROPERTY <i>(Type or Account)</i>	b. BALANCE AT BEGINNING OF PERIOD		c. ADDITIONS <i>(in dollars)</i>	d. DELETIONS <i>(in dollars)</i>	e. BALANCE END OF PERIOD	
	(1) Acquisition Cost <i>(in dollars)</i>	(2) Quantity <i>(in units or acres)</i>			(1) Acquisition Cost <i>(in dollars)</i>	(2) Quantity <i>(in units or acres)</i>
10. LAND						
11. OTHER REAL PROPERTY						
12. OTHER PLANT EQUIPMENT						
13. INDUSTRIAL PLANT EQUIPMENT						
14. SPECIAL TEST EQUIPMENT						
15. SPECIAL TOOLING <i>(Government Title Only)</i>						
16. MILITARY PROPERTY <i>(Agency - Peculiar)</i>						
17. GOVERNMENT MATERIAL <i>(Government - Furnished)</i>						
18. GOVERNMENT MATERIAL <i>(Contractor - Acquired)</i>						

19. CONTRACTOR REPRESENTATIVE

a. TYPED NAME <i>(Last, First, Middle Initial)</i>	b. SIGNATURE	c. DATE SIGNED <i>(YYMMDD)</i>
--	--------------	-----------------------------------

20. DOD PROPERTY REPRESENTATIVE

a. TYPED NAME <i>(Last, First, Middle Initial)</i>	c. SIGNATURE	d. DATE SIGNED <i>(YYMMDD)</i>
b. TELEPHONE NUMBER <i>(Commercial and DSN)</i>		

ABSTRACT

High quality single crystals of manganese doped yttrium orthoaluminate, Mn:YAlO₃ and its analogs have been grown by the Czochraski technique. The crystals have been characterized by chemical analysis, x-ray diffractometry, optical spectroscopy, electron paramagnetic resonance spectroscopy, and tested in the holographic recording experiments. Mn²⁺, Mn³⁺, and Mn⁴⁺ ions were identified and described in as-grown crystals. The reversible photoexcitation reaction $\text{Mn}^{4+} \Leftrightarrow \text{Mn}^{5+} + e$ and associated with it coloration and diffraction grating recording were studied in detail. The efficient diffraction grating recording was obtained in the crystals in one-color recording scheme and two-color recording scheme. Holographic recording tests of Mn:YAlO₃ at IBM Almaden Research Center demonstrated high potential of the material for applications in optical data storage. The project generated significant interest among students and faculty at Norfolk State University, as well as in the research community, and attracted further substantial support from NSF.

EXECUTIVE SUMMARY

During the two and a half years of the project, the Team of Norfolk State University, Alabama A&M University, and Adams-Brown Services, Inc. in collaboration with University of Alabama in Huntsville, IBM Almaden Research Center, NEC Research Institute (Princeton, NJ), CREOL/University of Central Florida, and Hamburg University (Hamburg, Germany) obtained the following major results.

High optical quality large single crystals of Mn doped YAlO_3 (Mn:YAlO_3) and its analogs (YbAlO_3 , GdAlO_3 , $\text{Gd}_{1-x}\text{La}_x\text{AlO}_3$, and CaYAlO_4) were grown by the Czochralski technique with various Mn concentrations, codoped with Ce and/or Ca, in different growth conditions. They were characterized by chemical analysis, x-ray diffractometry, optical spectroscopy, electron paramagnetic resonance spectroscopy, and tested in the holographic recording experiments. It was found that Mn entered most of the crystals above in the form of Mn^{2+} and Mn^{4+} ions. In YAlO_3 crystals codoped with Ce, Mn^{3+} ions were also unambiguously identified. Under exposition of Mn:YAlO_3 to a laser light of 530 nm or shorter wavelength, photoexcitation of Mn^{4+} to Mn^{5+} occurred. It was accompanied with a strong photocoloration of the material and a change in its index of refraction. Consequently, efficient diffraction grating can be recorded in the crystals in one-color recording scheme and two-color recording scheme. The diffraction behavior of Mn:YAlO_3 implies the non-local holographic response in the material that is favorable in holographic recording. However, due to the strong photoinduced optical absorption in the region of Mn^{4+} emission around 715 nm, Mn:YAlO_3 is unlikely to be useful as a solid state laser material.

The illumination with red light (630 nm or longer wavelength) did not affect the photoinduced coloration and the recorded grating, so that it can be applicable for non-volatile reading of the stored information. At room temperature the photoinduced grating can be stored in the crystal for years and it can be erased within minutes at a temperature above 250°C. Holographic recording tests of Mn:YAIO₃ at IBM Research Center demonstrated high potential of the material for applications in optical data storage.

The project attracted substantial interest among students and faculty at Norfolk State University (NSU) as well as in the research community. It initiated the larger ongoing research component in the supported by NSF Center for Photonic Materials at NSU¹.

Most of the obtained results have been reported in 19 conference presentations, 7 referred papers, 1 pending patent application, and 5 student theses listed in APPENDIX A. They are in the public domain (except for the patent application), readily accessible, and are not presented in this Report. However, the latest unpublished results and some details about the crystal growth and materials characterization of Mn-doped aluminates are included below. A list of participants is also presented.

¹ "A study of photoinduced color centers in manganese doped aluminates" G.B. Loutts, October 1998-September 2003 (major research component in the NSF CREST Grant #HRD-9805059, total funding of \$4,500,000).

TABLE OF CONTENTS

A. INTRODUCTION	6
B. CRYSTAL HOST SELECTION	7
C. CRYSTAL GROWTH AND MATERIAL CHARACTERIZATION	8
D. TWO-COLOR HOLOGRAPHIC RECORDING SCHEME ALLOWING NON-VOLATILE READING IN Mn:YA10_3	12
D1. Introduction	12
D2. Experimental Samples	14
D3. Experiments with 632.8 nm writing beams	15
D4. Experiments with 647 nm writing beams	15
D5. Discussion	19
D6. Summary	21
E. SPECTROSCOPIC CHARACTERIZATION OF MANGANESE DOPED CaYA10_4	34
F. ORGANIZATION AND PARTICIPATION	37
APPENDIX A	39
A1. Papers in Referred Journal	39
A2. Presentations at Scientific Conferences	39
A3. Student Theses	41

A. INTRODUCTION

The reversible change in color of a material under light irradiation, or photochromism, has been observed in many oxide materials including glass, sodalite, apatite, TiO_2 , CaTiO_3 , and SrTiO_3 [1,2]. Photochromism can occur when one or two species of impurities are involved, and charge is transferred from one to the other. This process is accompanied with the change in index of refraction and may be useful for storage of volume holograms. In centrosymmetric crystals, an absorption grating with the diffraction efficiency of up to 3.7% [3] can be recorded. In noncentrosymmetric crystals, for example, in ferroelectrics like LiNbO_3 , the storage is associated with the net transport of charge from one part of the crystal to another. This sets up a space charge field that can strongly modulate the refractive index due to the electro-optical effect. The diffraction efficiencies of more than 50% can be obtained in such materials. However, the usual problems in both kinds of crystals are the thermal stability and the destructive readout of the hologram. Room temperature decay times vary from less than a second in Fe doped SrTiO_3 ($\text{Fe}:\text{SrTiO}_3$) [4] and minutes in $\text{Ni,Mo}:\text{CaTiO}_3$ [4] to a month in $\text{Fe}:\text{LiNbO}_3$ [2]. The better thermal stability of recorded holograms in $\text{Fe}:\text{LiNbO}_3$ is due to the high activation energy (~ 1.4 eV) of the Fe traps [5]. To prevent the hologram from destruction during readout in LiNbO_3 , a thermal fixing at temperatures above 100°C can be employed. The fixing extends the storage time, which can be as long as a few years, but it also leads to decay of the diffraction efficiency.

Recently, we observed a strong photochromism in manganese doped crystals of yttrium orthoaluminate ($\text{Mn}:\text{YAlO}_3$) excited with a 530 nm wavelength light or shorter [6]. The color change from yellowish, associated with Mn^{4+} absorption, to dark blue-grayish (mostly due to Mn^{5+} absorption) is due to photoionization of Mn^{4+} to Mn^{5+} . In a standard two-beam coupling

arrangement with an intersection angle $2\Theta = 0.01-0.025$ rad, we observed an energy exchange between writing 514.5 nm Ar^+ laser beams and obtained diffraction efficiency in the range from 1.1% (with a 930 nm reading beam) to 53% (with a 514.5 nm reading beam) [6,7]. The photoinduced coloration and associated with it diffraction grating is stable at room temperature for over a year and can be erased within minutes at temperatures above 250°C. These properties suggest that Mn:YAlO_3 shows promise for applications in holography and optical storage. This was a motivation for us to study Mn:YAlO_3 crystal in detail and to search for other oxide crystalline hosts in which Mn ions could have a similar optical behavior.

B. CRYSTAL HOST SELECTION

Mn enters the YAlO_3 host in the form of Mn^{2+} ions (Mn^{2+} ionic radius $R_{\text{Mn}}=0.96$ Å), substituting Y^{3+} ions ($R_{\text{Y}}=1.02$ Å); and Mn^{4+} ions ($R_{\text{Mn}}=0.53$ Å), substituting Al^{3+} ions ($R_{\text{Al}}=0.53$ Å). In Mn:YAlO_3 codoped with cerium, a substantial fraction of Mn incorporates in the crystal as Mn^{3+} ($R_{\text{Mn}}=0.65$ Å), substituting Al^{3+} [9]. (All the ionic radii are taken in Ref. [8]). Mn^{5+} ions, which are formed due to photoionization of Mn^{4+} ions, reside in the Al octahedral sites. Since Mn^{5+} ions are relatively small and, to our knowledge, have not been reported in octahedral lattice positions in crystals, their instability may be responsible for the reverse reaction $\text{Mn}^{5+} + e \rightarrow \text{Mn}^{4+}$. By varying the size of the octahedral sites in the host, one may be able to affect the state of equilibrium and kinetics of the disproportionation reaction. Clearly, the site should be small enough to contain Mn^{5+} ions, but large enough to accommodate Mn^{4+} and Mn^{3+} ions at the same time. In YAlO_3 the aluminum octahedron is almost ideal with the Al-O distance of 1.90 Å [9]. Interestingly, a similar photoinduced coloration was reported in Mn doped corundum [10], where the aluminum octahedron is strongly distorted but the average Al-O distance is equal to

1.90 Å. The as-grown Mn:Al₂O₃ changed color from amber to gray-violet when been irradiated with ultraviolet at 79K. The coloration, however, was stable at a low temperature only. In contrast with YAlO₃ and Al₂O₃, no photoinduced coloration has been reported in Mn⁴⁺ doped YAG where Al-O distance is as long as 1.94 Å [11]. We could not obtain any coloration in Mn⁴⁺:YAG either. Consequently, our selection of hosts for Mn⁴⁺ doping was limited to those with octahedral aluminum sites with average Al-O distance close to 1.90 Å. We selected hosts with the same orthorhombic (space group Pbnm) crystal structure as in YAlO₃, but with lattice size somewhat smaller than in YAlO₃ (i.e., YbAlO₃) and somewhat larger than in YAlO₃ (i.e., GdAlO₃). Mixed orthoaluminate hosts Gd_{1-x}La_xAlO₃ with x=0.23, 0.37, and 0.50; and crystal structure changing from the orthorhombic system to the rhombohedral system (space group R-3m) have also been studied.

C. CRYSTAL GROWTH AND MATERIAL CHARACTERIZATION

Manganese-doped single crystals of YAlO₃, CaAlO₄, YbAlO₃, and Gd_{1-x}La_xAlO₃ with x=0, 0.23, 0.37, and 0.5 were grown by the Czochralski technique in iridium crucibles under nitrogen atmosphere with 0.2% of oxygen. The charges were prepared with Al₂O₃ and Y₂O₃ of 99.999% purity; and Yb₂O₃, Gd₂O₃, and La₂O₃ of 99.99% purity. Manganese was introduced in the charge as MnO₂ of 99.9% purity in the concentration of 0.05, 0.5, and 1.0 at.% with respect to Al. The YAlO₃ crystals were grown on seeds oriented along the "a" direction of the orthorhombic unit cell (Pbnm notation). Other orthoaluminates were nucleated on iridium wires. They became single crystalline after several millimeters of pulling and the final orientation of their boules was close to the crystallographic "c" axis. During growth, the pull rate was maintained at 1.5 mm/h and the rotation rate at 15 rpm.

In agreement with Ref. [12], it was progressively more difficult to crystallize the orthoaluminates as the size of the rare earth ion decreased from 1.05 Å for Gd^{3+} to 0.99 Å for Yb^{3+} . In fact, in order to initiate nucleation of the $YbAlO_3$ phase, its melt had to be substantially supercooled. Otherwise, a more stable $Yb_3Al_5O_{12}$ garnet phase was formed. Moreover, in subsequent growth runs we were unable to employ $YbAlO_3$ seeds due to their decomposition into a mixture of $Yb_3Al_5O_{12}$ and $Yb_4Al_2O_9$ phases in the vicinity of a hot melt. However, once an $YbAlO_3$ crystallite was nucleated on an iridium wire, it could be further grown and then cooled down to room temperature without any decomposition.

In order to alter manganese valence states, three 0.5%Mn:YAlO₃ crystals were codoped with cerium in the concentration of 0.05, 0.1 and 0.5 at.%; one crystal was codoped with 0.5 at.% of calcium; and one crystal was codoped with both Ca and Ce in the concentration of 0.5 at.% each.

As-grown Mn:YAlO₃ and Mn:YbAlO₃ crystals were free of cracks, inclusions and twins; and had yellowish color. In both materials the addition of Mn removed the red-brown coloration characteristic of their undoped crystals grown in a neutral or oxidizing ambient atmosphere. The Ce-codoped crystals were pinkish, Ca-codoped crystal was brown while Ca,Ce codoped crystals were grayish. The manganese concentration in the crystals, determined by electron microprobe analysis and by atomic absorption, was 10-12 times lower than that in the melt. The concentrations of Ca and Ce in the crystal versus the ones in the melt were about 2 times lower.

The color of Mn doped $Gd_{1-x}La_xAlO_3$ crystals was yellow-brownish. They contained cracks and numerous twin planes intersecting at right angles. Apparently, the tendency of rare earth orthoaluminate crystals to form twins increases for larger rare earth ions. This is related to the ratio between lattice parameters "b" and "a" of the orthoaluminates which varies from 1.040

in YbAlO₃ to 1.010 in GdAlO₃ and reaches unity in SmAlO₃ [13]. At this point, the crystal structure changes from the orthorhombic system (Pbnm) to the rhombohedral system (R-3m). In Gd_{1-x}La_xAlO₃ mixed orthoaluminates, the average rare earth radius is equal to the radius of Sm³⁺ (1.08 Å) at x≈0.27. However, according to the x-ray powder diffraction data, presented in Table 1, the change in crystal structure occurred in the material with nominal composition of Gd_{0.5}La_{0.5}AlO₃. The data were obtained with a Rigaku D/Max-2200TB diffractometer, Cu Kα₁ radiation. A diffracted beam monochromator and silicon standard were used to improve the resolution and accuracy. Calculation of unit cell parameters was performed with the Jade 3.0 software, compiled by the method of least squares from 30-40 reflections from planes at reflection angles 2Θ=20-90 degrees.

Table 1. Lattice parameters of Mn doped orthoaluminate single crystals

Nominal charge composition	Crystal structure	Lattice parameters, Å		
		a	b	c
YAlO ₃	Pbnm	5.178(1)	5.328(1)	7.367(1)
0.5%Mn:YAlO ₃	Pbnm	5.169(2)	5.317(2)	7.354(3)
YbAlO ₃	Pbnm	5.131(1)	5.336(1)	7.314(1)
0.5%Mn:YbAlO ₃	Pbnm	5.122(1)	5.326(1)	7.303(2)
GdAlO ₃	Pbnm	5.246(2)	5.295(1)	7.433(1)
0.5%Mn:GdAlO ₃	Pbnm	5.246(3)	5.281(3)	7.405(4)
0.4%Mn:Gd _{0.73} La _{0.27} AlO ₃	Pbnm	5.286(2)	5.297(1)	7.489(1)
0.4%Mn:Gd _{0.68} La _{0.32} AlO ₃	Pbnm	5.289(1)	5.296(1)	7.494(1)

0.9%Mn:Gd _{0.5} La _{0.5} AlO ₃	R-3m	5.312(1)	-	12.985(3)
---	------	----------	---	-----------

References:

1. B.W. Faughnan, D.L. Staebler, and Z.J. Kiss, In "Applied Solid State Science," Volume II, (R. Wolfe, Ed.), p. 107. Academic Press, New York, 1971.
2. D.L. Staebler, "Oxide optical memories: photochromism and index change", J. Solid State Chem., 12, pp.177-185, 1975.
3. H. Kogelnik, "Coupled wave theory for thick hologram gratings," Bell Syst. Tech. J. 48, 1969, 2909-2947.
4. B.W. Faughnan, "Photochromism in transition-metal-doped SrTiO₃", Phys. Rev. B. 10, pp.3623-3636, 1971.
5. D.L. Staebler and W. Phillips, "Hologram storage in photochromic LiNbO₃," Appl. Phys. Lett., 24, pp. 268-270, 1974.
6. G.B. Loutts, M. Warren, L. Taylor, R.R. Rakhimov, H.R. Ries, G. Miller III, M.A. Noginov, M. Curley, N. Noginova, N. Kukhtarev, H.J. Caulfield, and P. Venkateswarlu, "Manganese doped yttrium orthoaluminate: a potential material for holographic recording and data storage," Phys. Rev. B, 57, pp. 3706-3709, 1998.
7. M.A. Noginov, N. Noginova, M. Curley, N. Kukhtarev, H.J. Caulfield, P. Venkateswarlu, G.B. Loutts, "Optical characterization of Mn:YAlO₃, material for holographic recording and data storage," J. Opt. Soc. Amer. B, 15, pp. 1463-1468, 1998.
8. R.D. Shannon, "Revised effective ionic radii and systematic studies of interatomic distances in halides and chalcogenides," Acta Cryst., A32, pp. 751-767, 1976.
9. R. Diehl, G. Brant, "Crystal structure refinement of YAlO₃, a promising laser material," Mat. Res. Bull., 10, pp. 85-90, 1975.

10. S. Geshwind, P. Kisliuk, M.P. Klein, J.P. Remeika, D.L. Wood, Sharp-line fluorescence, electron paramagnetic resonance, and thermoluminescence of Mn^{4+} in $\alpha-Al_2O_3$, Phys. Rev., 126, pp. 1684-1686, 1962.
11. F.S. Galasso, "Structure and properties of inorganic solids," London, Pergamon Press, 1970, 297 p.
12. I.A. Bondar, A.K. Shirvinskaya, V.F. Popova, I.V. Mochalov, and A.O. Ivanov, "Thermal stability of orthoaluminates of rare earth elements of the yttrium subgroup", Sov. Phys. Dokl., 24, pp. 289-292, 1979.
13. P.D. Dernier and R.G. Maines, "High pressure synthesis and crystal data of the rare earth orthoaluminates", Mat. Res. Bull., 6, pp. 433-440, 1971.

D. TWO-COLOR HOLOGRAPHIC RECORDING SCHEME ALLOWING NON-VOLATILE READING IN $Mn:YAlO_3$

Abstract

We propose and experimentally demonstrate the possibility of two-color grating recording in $Mn:YAlO_3$, a potential material for holographic data storage. This type of recording allows for non-volatile retrieving of recorded information at the recording wavelength. 256x256 pixel page had been recorded (using red and green laser beams) and retrieved with the bit error rate (BER) equal to 6×10^{-7} .

1. Introduction

As it has been shown in Refs. [1-3], holographic gratings with high diffraction efficiency can be recorded in $Mn:YAlO_3$ with green or blue laser beams. The holographic storage time in $Mn:YAlO_3$, extrapolated to room temperature, is much greater than ten years. Recorded gratings

can be erased in few minutes by heating the crystal to 270°C. These properties in combination with the high optical quality of the crystal give Mn:YAlO₃ promise as a material for holographic data storage.

In Mn:YAlO₃, the photoinduced coloration and associated change in refractive index are due to two-step photoionization of Mn⁴⁺ [1,2,4,5]. In the first step, absorption at the transition ⁴A₂→⁴T₂ (λ_{max}=480 nm, Figure 1 trace 1) followed by internal relaxation ⁴T₂→²E populates the metastable level ²E (ε_{2E} 1.4x10⁴ cm⁻¹, τ_{2E}=3 ms [4]). The second photon is absorbed from ²E to the excited state associated with the intense charge transfer (CT) band (λ_{max}=290 nm). Trace 2 in Figure 1 presents CT absorption in unexposed Mn:YAlO₃ and trace 3 is of a strongly photoexposed sample (where the Mn⁴⁺ concentration is significantly depleted). We assume that the difference between spectra 2 and 3 (trace 4) corresponds approximately to CT absorption of Mn⁴⁺. [Mn²⁺ ions, which concentration in photodarkened Mn:YAlO₃ crystal is also depleted (in comparison with unexposed sample) [6], can, in principle, contribute to ultraviolet (UV) absorption too.]

For high fidelity retrieval of holograms containing a wide range of spatial frequencies, writing and reading must be done at the same wavelength. For λ 0.55 μm, the one-color sensitivity range of Mn:YAlO₃, reading will necessarily cause erasure (or, to be more exact, extra gray coloration of the grating volume). We propose a two-color recording scheme allowing non-volatile reading in Mn:YAlO₃. (The same concept in LiNbO₃ was discussed in Refs. [7,8]). Trace 5 presents the CT absorption spectrum in Mn:YAlO₃ shifted to low energies by ε_{2E}. According to the assumption above, the band peaking at 510 nm corresponds approximately to the excited state absorption (ESA) spectrum of Mn⁴⁺. The comparison of traces 1 and 5 shows that substantial ESA occurs at λ 550 nm, where ground state absorption (GSA) of Mn⁴⁺ is negligible.

(ESA in Mn:YAlO₃ at $\lambda=632.8$ nm has been reported recently in Ref. [9].) This suggests that when the ²E level is populated with blue-green light, yellow or red laser beams can record a grating. (In the following text we will refer blue-green light as green light and yellow-red light as red light.) In the absence of green light, red reading light will not cause erasure. The trade-off for this advantage is a uniform gray photocoloration background.

It is easy to show that, in the first approximation, the rate of photoionization grating build up (caused by combination of red recording light and green gating light) is proportional to

$$W = \sigma_{gs}^{green} F^{green} \sigma_{es}^{red} F^{red}, \quad (1)$$

where σ_{gs}^{green} is the ground state absorption of Mn⁴⁺ ions at green light wavelength, F^{green} is the photon flux of green light, σ_{es}^{red} is the excited state absorption of Mn⁴⁺ ions at red light wavelength, and F^{red} is the photon flux of red light. The contrast of the photoionization grating should be proportional to

$$V_{min/max} = \sigma_{es}^{red} F^{red} / (\sigma_{es}^{red} F^{red} + \sigma_{es}^{green} F^{green}), \quad (2)$$

where σ_{es}^{green} is the excited state absorption cross section of Mn⁴⁺ ions at green light. Thus, a high red light intensity and high σ_{es}^{red} are beneficial both in terms of grating recording rate and contrast. For constant red pumping, the green intensity can be optimized for a trade-off between recording rate and contrast.

2. Experimental samples

In the experiments we used 1cmx1cmx1cm samples of nominally 0.5% Mn doped YAlO₃ crystals (the concentration of Mn ions in the crystal was approximately ten times less than that in the melt) cut along the **a**, **b**, and **c** crystallographic axes. The optical quality of the samples was very high and the scatter was very low. As it has been shown in work [10], the maximum

diffraction efficiency in Mn:YAlO₃ can be observed when light polarization **E** is parallel to the crystallographic axis **c**². This light polarization direction was used in all our experiments.

3. Experiment with 632.8 nm writing beams

Experimentally, we interfered two 632.8 nm He-Ne laser beams in Mn:YAlO₃ at a small crossing angle of 9 mrad and illuminated the same volume with 514.5 nm Ar laser light. The intensity of the 632.8 nm beams was 1.3W/cm² and that of the 514.5nm gating light was 0.05 W/cm². The diameter of the He-Ne laser beams in the sample was determined by the diameter of the d=0.3 mm pinhole made in a mask attached to the front surface of the sample. The pinhole transmitted only central parts of the beams which had almost uniform light distribution and plane wavefront. It also helped to align the interacting beams more accurately.

After several minutes of recording, when one of the two red recording beams was blocked, the diffraction spot could be observed on the screen behind the crystal. This was the evidence of the two-color holographic recording in Mn:YAlO₃. This grating could not be disturbed or erased by reading red light, apparently it had the same long life-time as the grating recorded with single-color Ar laser beam, and it could be easily erased in few minutes on hot plate at t 270°C.

Digital holographic recording experiment required much higher power of red light than our 5 mW He-Ne laser could provide. That is why all further experiments were done using W 647 nm Kr laser.

4. Experiment with 647 nm writing beams

4.1. Experimental setup

² In our earlier publications [1-4,6], the optical axes in Mn:YAlO₃ were determined incorrectly. The conversion between old (incorrect) and new (correct) axes notations is as follows: **a_{old}**→**c_{new}**, **b_{old}**→**a_{new}**, **c_{old}**→**b_{new}**. See Ref. [5] for more details.

Digital holographic recording has been conducted using the tester, which was described in detail in Ref. [11], Figure 2. The laser light is delivered to the tester by a polarization-maintaining optical fiber and split into the object and reference beams by the beamsplitter (BS). Half-wave plates ($\lambda/2$) and polarizers (P) control the intensity of the laser light in the both channels, photodetectors (D) monitor the light intensity, and shutters (S) gate beams on and off. After the shutter, the object beam is raised by a periscope prism (PP) and its diameter is increased by a 20x beam expander (BE). The 15 mm square aperture (A) selects the center of the beam, producing a flat top profile. The data mask (MA), 256x256 array of random bits, is imaged through the crystal (SA) by Fourier lenses (L1) and (L2) to the CCD camera (C). Fused silica compensator plates (CP) adjust the effective optical path between the two lenses for best imaging. The reference beam (dotted line) is expanded by the telescope (T). After reflecting from a right-angle turning prism (TP), the reference beam runs below the object beam and then it is brought up to the sample with the mirror (M) and periscope (DP). This allows one to change the angle between writing and reference beams in a very wide range, above the minimum angle of 27 degrees. Smaller angles cannot be obtained because periscope obscures object beam. The polarizations of the both beams are controlled by liquid-crystal Senarmont polarization rotators (R).

In our holographic digital recording experiment, the angle between 647 nm object and reference beams was equal to 90° . The Gaussian reference beam had the waist size $2w=6\text{mm}$ and the average intensity equal to 100 mW/cm^2 . The size of the object beam in the crystal was approximately equal to $4\text{mm}\times 4\text{mm}$ and its average intensity was equal to 2 mW/cm^2 . The gating 514.5 nm Gaussian laser beam was counterpropagating to the reference beam. It has the size $2w=4.5\text{ mm}$ and average intensity 230 mW/cm^2 .

4.2 Digital holographic recording

Figure 3a shows 64x64 portion of the 256x256 mask transmitted through the crystal to the CCD. In this image, the intensity distribution functions for 0's and 1's shown in Figure 3b practically do not overlap, manifesting very high optical quality of the crystal. When the Gaussian functions were fit to the tails of the distributions, the BER value equal to 10^{-12} has been calculated.

The holographic recording of the digital page in Mn:YAlO₃ was done at 300 sec exposure. The reconstructed holographic image of the mask (from the CCD) is depicted in Figure 4a and the corresponding intensity distribution histogram is given in Figure 4b. The BER value for the hologram is equal to 6×10^{-7} , which is a very good number resulting from the combination of high crystal quality, low scatter at (90 degrees), and high fidelity of the holographic recording. The diffraction efficiency η_i (defined as the ratio of the diffraction intensity to the incident light intensity) was low, 4×10^{-6} . It will be discussed further in the text.

4.3 Plane wave grating recording

In the plane-wave experiment, the telescope, beam expander, mask, and lenses have been removed from the setup in Figure 2. The resulting writing beams were collimated $2w=3.1$ mm Gaussian beams of equal intensity. One beam was perpendicular to the crystal face and another was tilted at 27 degrees to the first beam. The 514.5 nm gating beam ($2w=2.8$ mm or $2w=4.5$ mm) was counterpropagating to the beam at 27 degrees. Once intensity was calibrated, the result did not depend noticeably on the gating beam diameter.

In the diffraction kinetics experiment, the grating was recorded for five seconds. Then one beam was blocked and the diffraction efficiency was interrogated. After that both beams were open again and the grating was recorded for another five seconds. Then one beam was blocked again and the measurement was repeated, etc.

Figure 5 shows the set of $\sqrt{\eta_i}$ curves plotted *versus* time for several different power densities of green light and fixed power density of 647 nm red light. As it can be expected, the rate of holographic recording increases with the increase of green light intensity. However, at high intensity the photodarkening occurs rapidly, limiting the diffraction efficiency. The initial slopes of the curves in Figure 5 were used to calculate the holographic sensitivity (S) of two-color recording, $S = \frac{\sqrt{\eta_i}}{(P/s)l}$. Here P/s is the power density measured in the both red beams, t is the exposure time, and l is the beam interaction length. (In the geometry of experiment, which we used, l was estimated to be equal to 0.5 cm.) The sensitivity S scales with green light intensity almost linearly, except for high intensities, where the initial slope of the diffraction efficiency curve is apparently limited by the growth of absorption, Figure 6. In our experiment, the maximum gating ratio (the ratio between the sensitivity at green light power density (P/s₅₁₄) equal to 3.5W/cm² and that at P/s₅₁₄=0W/cm²) was equal to 220.

The experimental dependence of $\sqrt{\eta_i}$ on red light fluence is depicted in Figure 7 for different red light power densities and intermediate green light power density (0.7 W/cm²). According to our simple model, the growth rate should be linearly scaled with red light intensity. In this case all traces in Figure 7 should overlap and the sensitivity of holographic recording S should be independent of red light intensity. However, according to Figure 8, the sensitivity (S) derived from the growth curves in Figure 7, decreases with the increase of red light intensity. In principle, this reduction can be explained by ESA originating from the level ²E. At strong intensity of red light, the depopulation rate of ²E due to ESA can become comparable to that due to intracentral (mostly radiative) relaxation, $\tau_E=3$ ms. This can decrease excited state concentration of ²E and as well as the sensitivity of holographic recording. The ESA-induced

depopulation of the level 2E should be significantly strong at the ESA cross section (σ_{ESA}) comparable to

$$\sigma_{ESA} = hv\tau s/P, \quad (3)$$

where hv is the photon energy of red light. At $P/s=1 \text{ W/cm}^2$ and hv corresponding to 647 nm light, σ_{ESA} calculated according to Eq. (3) is equal to $1 \times 10^{-16} \text{ cm}^2$. This is a high value, which is however possible for ionization or charge transfer transitions. The accurate measurement of ESA cross section at 647 nm would be needed to prove this hypothesis. However, in Mn:YAlO_3 direct ESA measurements are strongly complicated by permanent photoinduced coloration caused by Mn^{5+} ions.

5 Discussion

Characteristics of several known advanced materials for holographic digital storage are compared in Table 1 (which is based on the table published in Ref. [12]). The parameters, which are difficult to be characterized quantitatively, are graded according to the scale “+++”, “++”, “+”, “0”, and “-“, where “+++” is the maximum grade and “-“ is the minimum grade. As it follows from Table 1, Mn:YAlO_3 in two-color recording scheme demonstrated the best (or one of the best) combination of such important qualities as image quality, scatter, hologram fidelity, stability, reusability, and non-volatility. The only poor characteristics of Mn:YAlO_3 were (relevant to each other) low diffraction efficiency and low sensitivity.

The sensitivity of one-color (514.5 nm) holographic recording, measured in the same tester setup which was used for two-color recording (at the angle between writing beams equal to 27 degrees) was also low (Figure 9, trace 1). As it could be expected in the case of two-step ionization process, the sensitivity of green light holographic recording was linearly proportional to the light intensity.

Because of strong photoinduced coloration in Mn:YAlO₃, significant amount of power of the reading beam is absorbed in the material. In this case, in order to characterize the diffraction strength and the modulation of the refraction index more adequately, the diffraction efficiency (η_t) can be redefined as the ratio of the diffracted beam intensity to the total intensity of beams passed through the crystal. Defined in these terms, high diffraction efficiency ($\eta_t=53\%$) was reported in the crystal [1] in a simple one-color plane-wave recording scheme at 514.5 nm. (In this measurement, the angle between writing beams was small (<10 mrad) and the beam diameters were restricted by a tiny pinhole diaphragm attached to the front surface of the crystal.) In the same setup, the diffraction efficiency η_i , defined in terms of incident power, is smaller $\eta_i=7.5\%$ [10]. However, it is much larger than that determined in the tester setup, $\eta_i=0.11\%$.

The one-color (514.5nm) holographic sensitivity measured in a simple setup discussed above at $\theta=7$ mrad is plotted in Figure 9, trace 2. These values are much higher than those of trace 1. As it was shown in Ref. [3], the diffraction efficiency in Mn:YAlO₃ decreases with the reduction of the diffraction grating period Λ . At $\Lambda=1.1$ μm , which corresponds to $\Theta=27^\circ$ and $\lambda=514.5$ nm, the diffraction efficiency is approximately equal to twenty percent of its maximum value at small angle Θ . Thus, the sensitivity at $\Theta=27^\circ$ should be $\sqrt{5}$ times smaller than that at small angle between writing beams. In Figure 9 trace 3, we plotted the sensitivity determined in the IBM tester setup (data of trace 1) multiplied by $\sqrt{5}$ to account for the grating period factor. Those adjusted sensitivity values are still much lower than the sensitivity values of trace 3.

Thus, low values of diffraction efficiency and sensitivity measured in two-color experiment are, most likely, not the characteristics of the material but the characteristics of the tester setup

(Figure 2), which apparently is not optimum for Mn:YAlO₃. Further studies are required to optimize the recording parameters and recording setup for this crystal.

It should be noticed that at relatively high recording intensity, the sensitivity in Mn:YAlO₃ can exceed that in LiNbO₃ (the most popular inorganic crystal used for holographic recording), Figure 9. Further improvement of sensitivity in Mn:YAlO₃ can be obtained via the variation of the recording wavelength, Figure 9 trace 4, and optimization of the crystal parameters (Mn concentration, annealing, etc.).

6 Summary

We have proposed and experimentally demonstrated two-color holographic recording in Mn:YAlO₃. This allows for non-volatile reading of the recorded information with red laser beam.

Non-volatile reading, together with very high quality of the crystal, low scatter, high fidelity of holographic recording, long storage time, and reusability of the crystal, makes Mn:YAlO₃, promising candidate to holographic storage media.

High quality two-color holographic recording of 256x256 array of random bits with the low BER value equal to 6×10^{-7} has been demonstrated.

The sensitivity of the to-color holographic recording was rather low. However, it probably can be strongly improved by the increase of the recording power density and optimization of the setup. It has been demonstrated that at one-color recording (at 514.5 nm), the holographic sensitivity in Mn:YAlO₃ can be as high as that in LiNbO₃.

References

1. G. B. Loutts, M. Warren, L. Taylor, R. R. Rakhimov, H. R. Ries, G. Miller III, M. A. Noginov, M. Curley, N. Noginova, N. Kukhtarev, J. C. Caulfield, P. Venkateswarlu,

- “Manganese-doped yttrium orthoaluminate: A potential material for holographic recording and data storage”, *Phys. Rev. B*, **57**, pp. 3706-3709 (1998).
2. M. A. Noginov, N. Noginova, M. Curley, N. Kukhtarev, H. J. Caulfield, P. Venkateswarlu, G. B. Loutts “Optical characterization of Mn:YAlO₃, a material for holographic recording and data storage”, *J. Opt. Soc. Am. B*, **15**, pp. 1463-1468 (1998).
 3. N. Noginova, W. Lindsay, M. A. Noginov, G. B. Loutts, L. Mattix, “Photorefractive effects in Mn-doped YAlO₃”, *JOSA B*, **16**, pp. 754-756 (1999).
 4. M. A. Noginov, G. B. Loutts, “Spectroscopic studies of Mn⁴⁺ ions in yttrium orthoaluminate”, *JOSA B*, **16**, pp. 3-11 (1999).
 5. M. A. Noginov, G. B. Loutts, N. Noginova, S. Hurling, S. Kück, “Spectroscopic characterization of photoinduced Mn⁵⁺ ions in YAlO₃”, *Phys. Rev. B*, **61**, pp. 1884-1891 (2000).
 6. M. A. Noginov, G. B. Loutts, M. Warren, “Spectroscopic studies of Mn³⁺ and Mn²⁺ ions in YAlO₃”, *JOSA B*, **16**, pp. 475-483 (1999).
 7. H. Guenther, R. M. Macfarlane, Y. Furukawa, K. Kitamura and R. R. Neurgaonkar, “Two-color holography in reduced, near-stoichiometric lithium niobate”, *Applied Optics*, **37**, 7611 (1998).
 8. K. Buse, A. Adibi and D. Psaltis, “Nonvolatile holographic storage in doubly doped lithium niobate crystal”, *Nature*, **393**, 665 (1998).
 9. M. A. Noginov, G. B. Loutts, K. Ross, T. Grandy, N. Noginova, B. Lucas, T. Mapp, “The role of traps and the balance of manganese valence states in Mn:YAlO₃, a materials for holographic recording and optical data storage”, in *Conference on Lasers and Electro-Optics, OSA Technical Digest (Optical Society of America, Washington DC, 1999)*, pp. 334-335.

10. M.A.Noginov, G. B.Loutts, P.P.Banerjee, M. Morrisey, R. A. Linke, "Studies of local and Non-local components in photorefractive response in Mn:YAlO₃", in *Conference on Lasers and Electro-Optics*, OSA Technical Digest (Optical Society of America, Washington, DC, 2000) pp. 6-7.
11. M.-P. Bernal, H. Coufal, R. K. Grygier, J. A. Hoffnagle, C. M. Jefferson, R. M. Macfarlane, R. M. Shelby, G. T. Sincerbox, P. Wimmer, G. Wittmann, "A precision tester for studies of holographic optical storage materials and recording physics", *Applied Optics*, **35**, pp. 2360-2374 (1996).
12. IBM J. Research and Development, **44**, pp. 341-368 (2000).

Table 2. Properties of prospective materials for holographic data storage.

	Image Quality	Scatter	Holo. Fidelity	Non-volatility	Reusability	S-1 (cm ² /J) (insident)	Stability	Thickness, mm
LiNbO ₃ :Fe one-color	+++	+++	+	-	+	0.02	0	10
LiNbO ₃ two-color	++	++	+	+	+	0.02	++	10
Polaroid photopol.	+++	-	0	+	-	20	+	0.5
PQ/PMMA	+	-	+	+	-	0.2-0.5	++	2
Bayer photoaddr. polymer	+++	0	++		-	0.002-0.02		0.1
Mn: YAlO ₃ two-color IBM tester setup	+++	+++	++	+	+	0.0022	++	10

Figure 1. Absorption spectra in Mn:YAlO₃. Right vertical axis corresponds to trace 1, left vertical scale corresponds to traces 2-5.

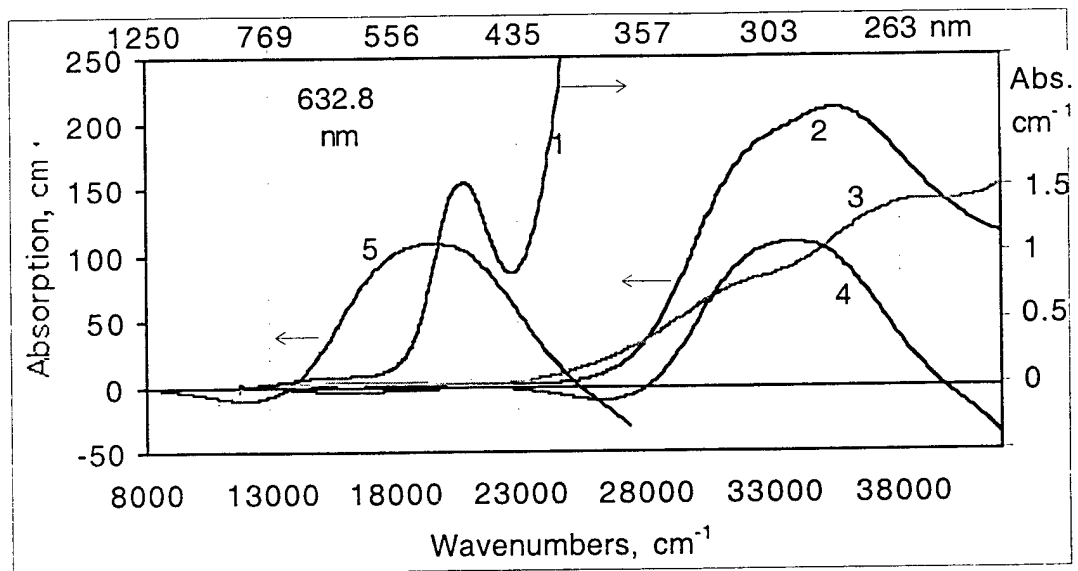

Figure 2. Schematic diagram of the holographic storage tester.

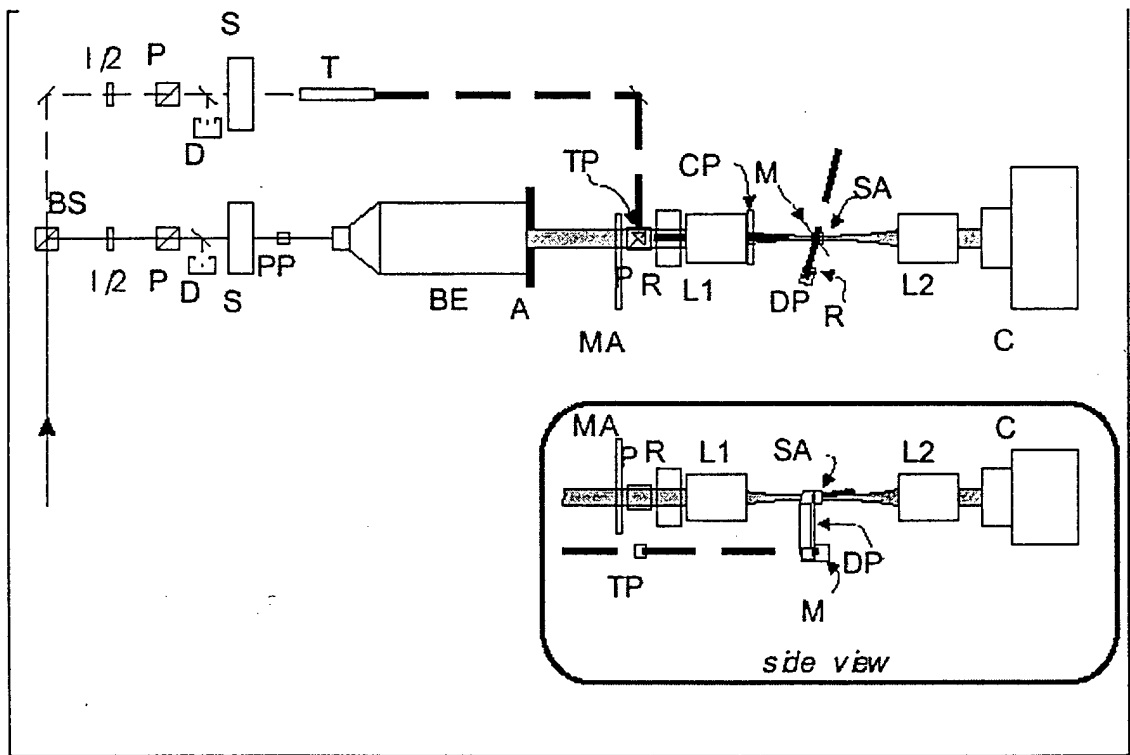
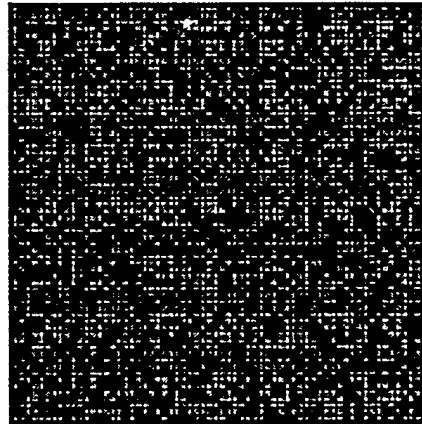

Figure 3. (a) - 64x64 portion of the 256x256 random bit data mask transmitted through the crystal to the CCD camera (at $\lambda=647$ nm); (b) - corresponding intensity distribution histogram of 0's and 1's. BER= 1×10^{-12} .

a



b

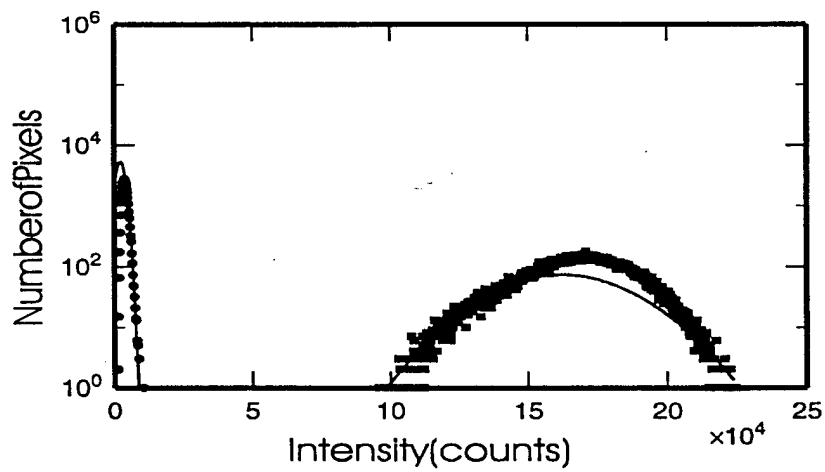
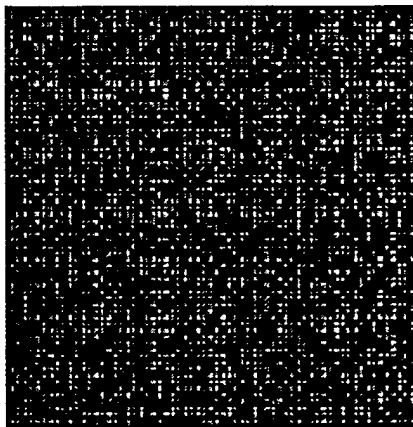
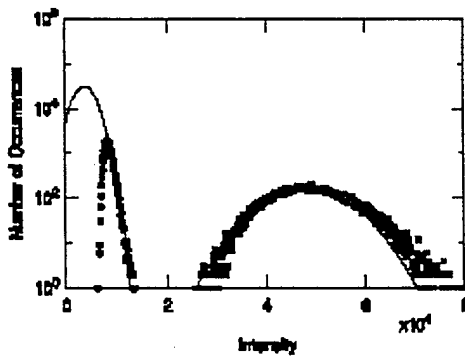

Figure 4. (a) - 64x64 portion of the 256x256 random bit data mask holographically recorded and retrieved in two-color experiment; (b) - corresponding intensity distribution histogram of 0's and 1's. BER= 6×10^{-7} .



a



b

Figure 5. Dependence of diffraction efficiency on red light fluence (647 nm, 1.3 W/cm²) at different intensities of green gating light (514.5 nm). 514.5 nm: ○ - 0 W/cm², ■ - 0.35 W/cm², ● - 0.7 W/cm², ▲ - 1.2 W/cm², ◆ - 3.5 W/cm², and ▼ - 7 W/cm².

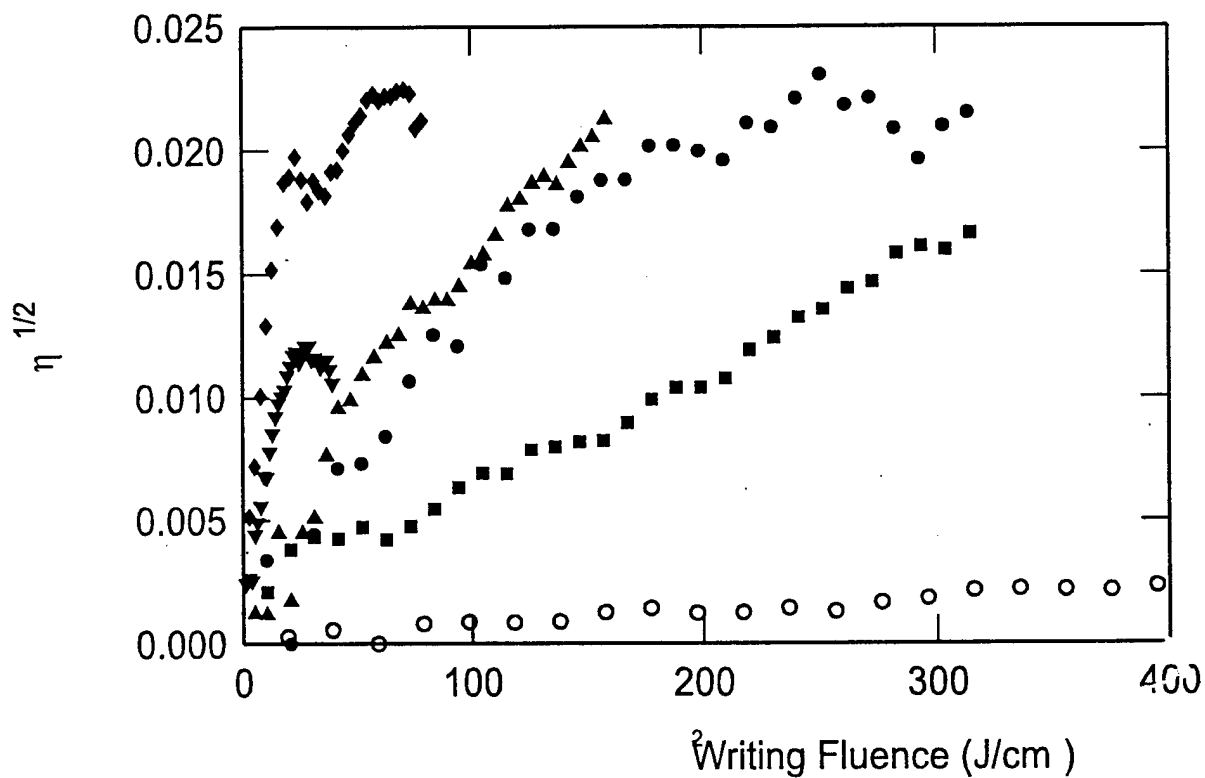

Figure 6. Sensitivity of red light holographic recording (647 nm, 1.3 W/cm²) plotted versus gating intensity (514.5 nm).

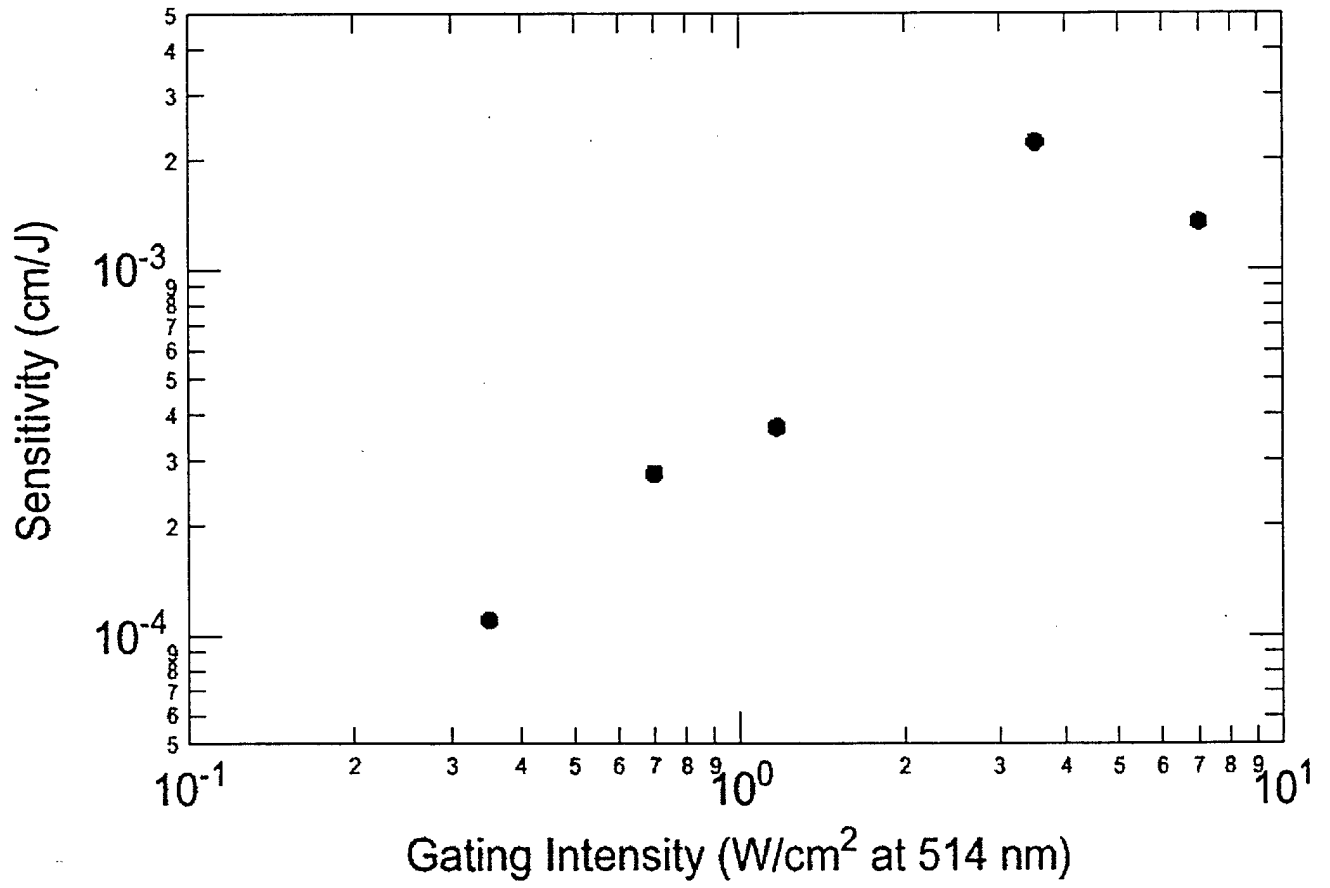

Figure 7. Dependence of diffraction efficiency on red light fluence (647 nm) at different red light intensities and intermediate green light intensity (514.5 nm, 0.7 W/cm²).
 647 nm: ▲ - 0.65 W/cm², ◆ - 0.78 W/cm², ■ - 0.9 W/cm², ▼ - 1 W/cm²,
 and ● - 1.3 W/cm².

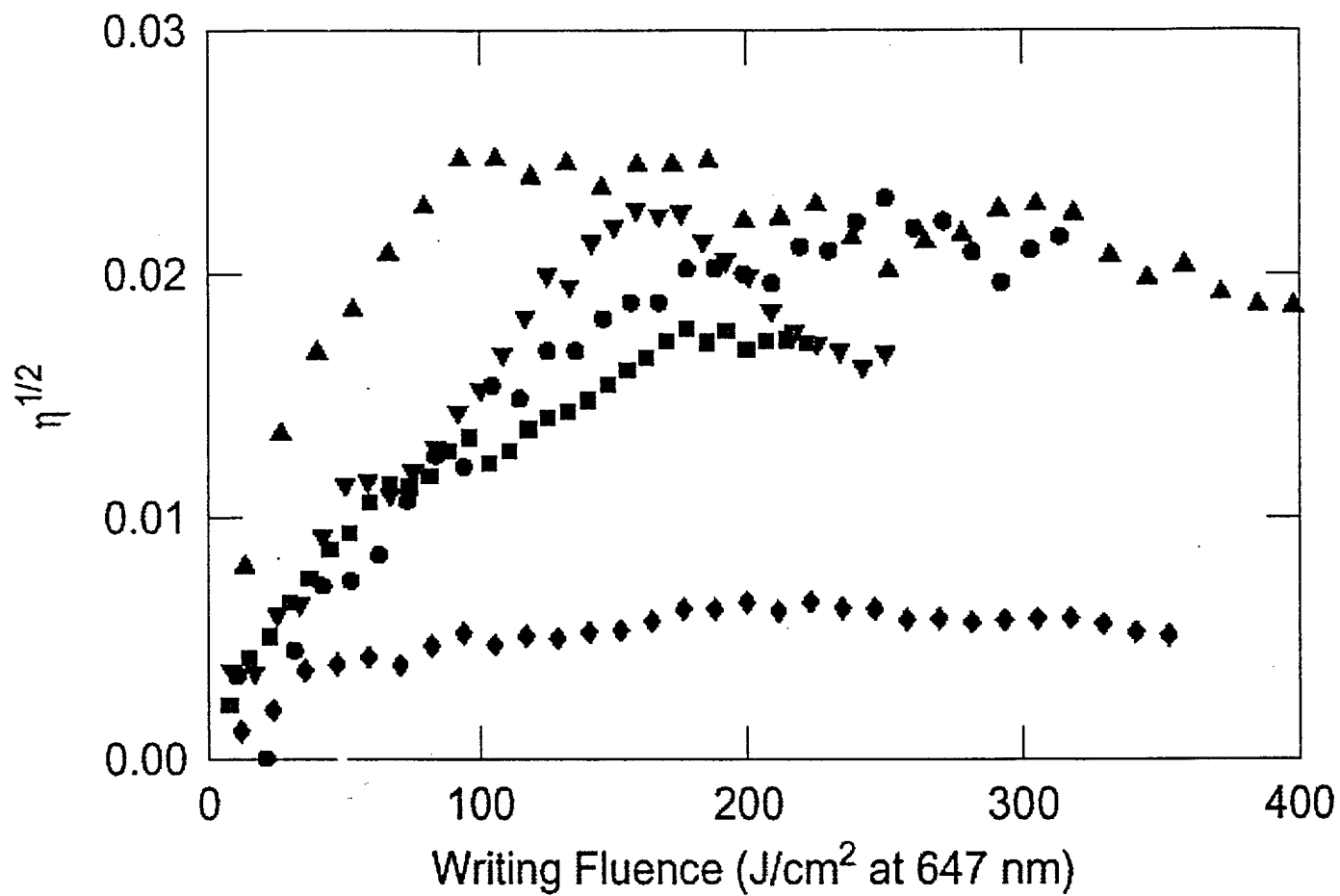

Figure 8. Sensitivity of red light holographic recording (647 nm) plotted versus red light intensity.

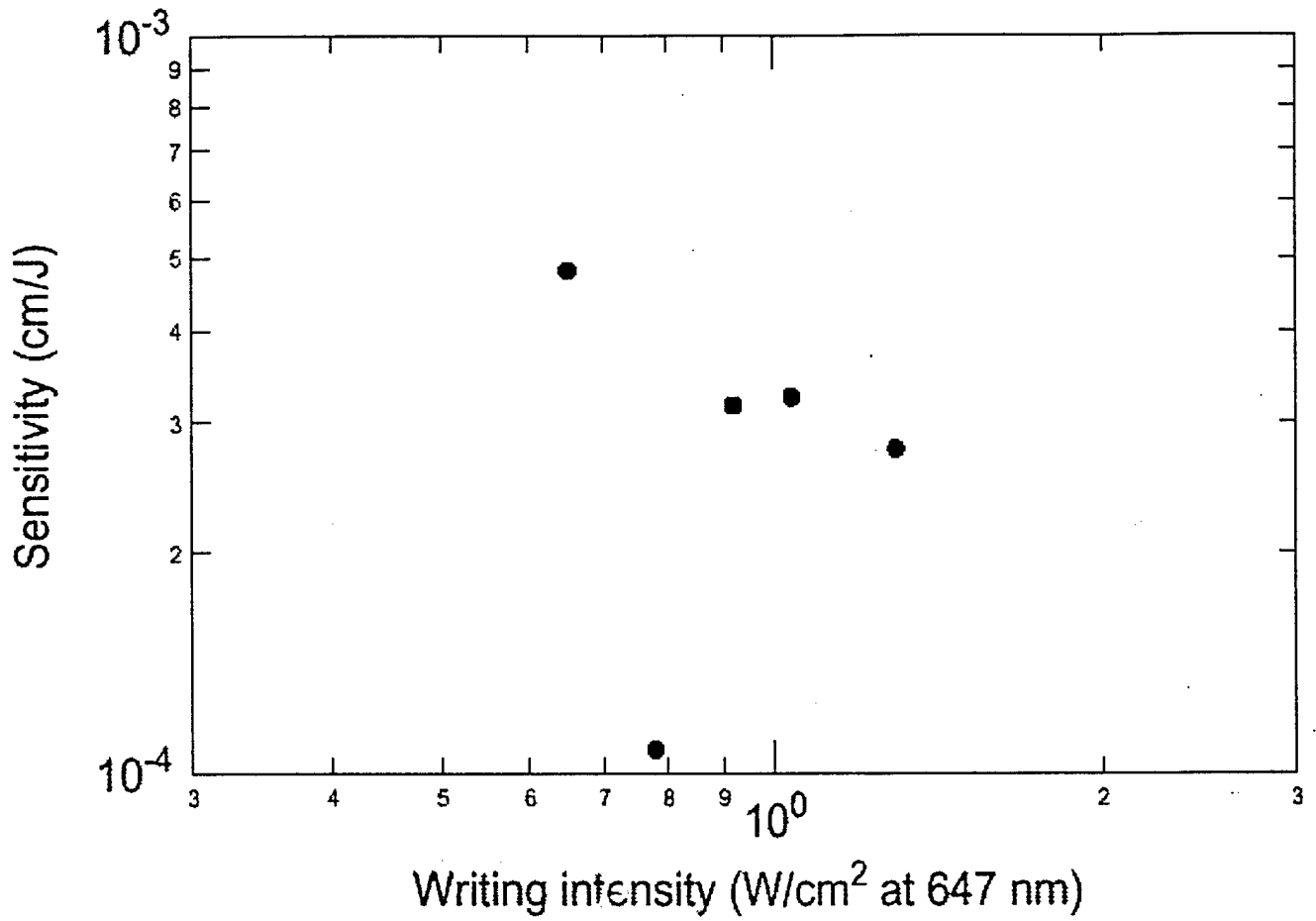
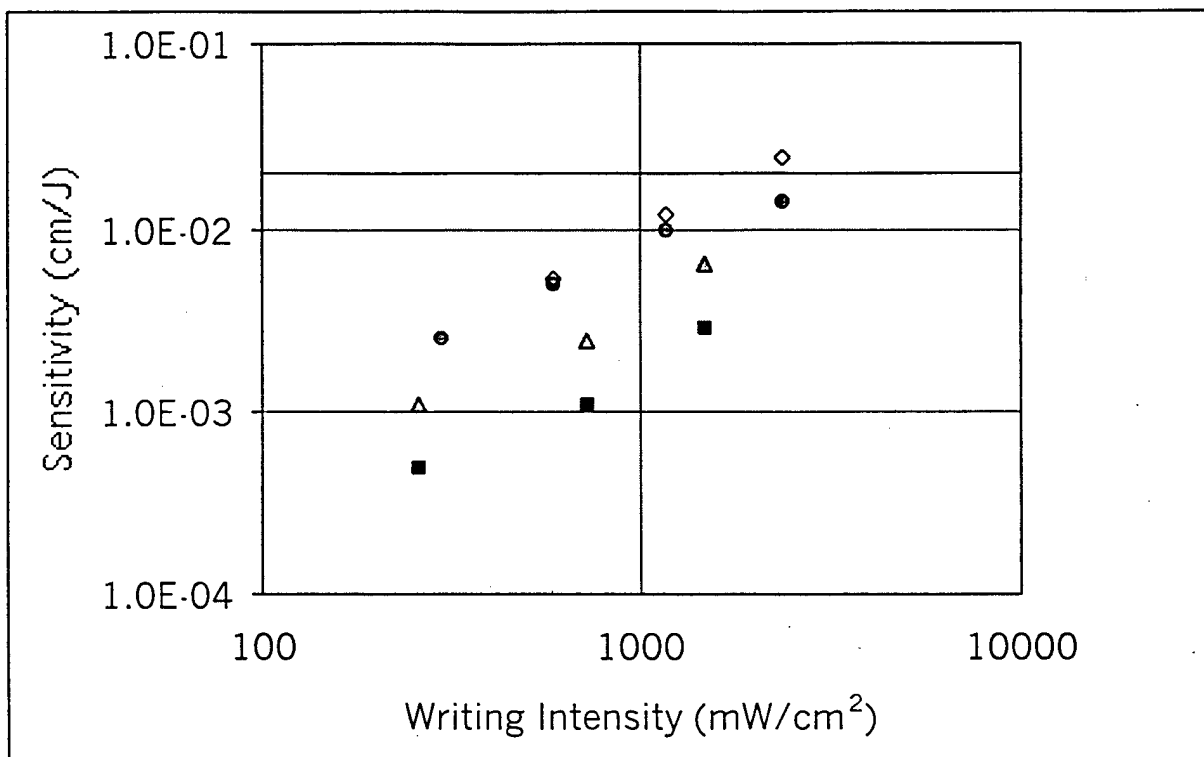

Figure 9. Sensitivity of one-color holographic recording (514.5 nm) as a function of light intensity. Squares – IBM tester setup, $\Theta=27^\circ$, circles – simple small-angle two-beam experiment, triangles – data from the IBM tester setup corrected for angle difference, diamonds – simple small-angle two-beam experiment at $\lambda=472$ nm. Horizontal line – sensitivity in LnNbO_3 .



E. SPECTROSCOPIC CHARACTERIZATION OF MANGANESE DOPED CaYAlO₄

We have grown and characterized a new crystal, manganese doped CaYAlO₄. The results of optical absorption, emission, kinetics and electron paramagnetic resonance (EPR) studies are below.

In search for novel photonic materials, we have grown and characterized manganese doped CaYAlO₄ crystals. This material is relevant to Mn:YAlO₃, a promising material for holographic data storage. Luminescence of Mn ions can make this material potentially interesting for tunable laser applications. Additionally, spectroscopic studies of Mn ions in this crystal may help in understanding properties of colossal magneto-resistance materials. In this work, using the Czochralski technique, we have grown several manganese doped CaYAlO₄ crystals and characterized their optical absorption, emission, and EPR properties.

The study of absorption spectra have shown the presence of Mn⁴⁺ ions (470 nm) and small concentration of Mn⁵⁺ ions (680 nm), Figure 1. The concentrations of these two valence states increased with the increase of Mn in the melt. It was also observed that in sharp contrast with Mn: YAlO₃, Mn⁵⁺ ions were present without any charge compensators and photoexposure. The co-doping of the crystals by Ce ions (ion small concentration) does not change the balance of Mn⁴⁺ and Mn⁵⁺ valence states.

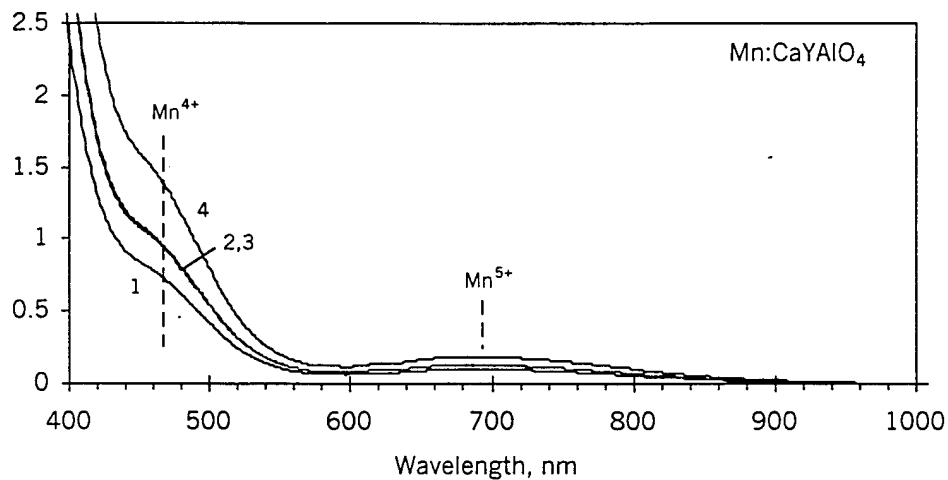

Fig. 1. Absorption in manganese doped CaYAlO_4 . 1 - Mn=0.1%, 2 - Mn=0.5%, 3 - Mn=0.5%, Ce=0.5%, 4 - Mn=2%.

Emission spectra recorded under 488 nm cw Ar^+ pumping showed a maximum at 710 nm which is indicative of the presence of Mn^{4+} ions in YAlO_3 , $\text{Y}_3\text{Al}_5\text{O}_{12}$, and other crystals. The Mn^{4+} emission spectra in the crystals with low Mn concentration and/or Ce co-doping appeared to be smoother than the spectra in single doped crystals with higher Mn concentration. The sharpness or the smoothness of the spectra may be associated with higher or smaller degree of ordering of Mn, Ca or Y sublattices in the material.

At Mn concentrations 0.5%, Mn^{4+} luminescence kinetics were single exponential and characterized by the decay-time of 2.4 ms. At higher Mn concentrations, 2%, the initial stage of the luminescence kinetics was characterized by a higher decay rate, corresponding to approximately 1.3 ms.

The electron paramagnetic resonance (EPR) studies have revealed a sharp microwave response near zero magnetic field. This response was attributed to non-resonant absorption of the microwave. It coexists with regular EPR absorption due to paramagnetic resonance of

Mn^{2+} and Mn^{4+} ions. The low field response has the opposite phase with respect to the paramagnetic absorption. This shows that $Mn:CaYAlO_4$ exhibits magnetically induced microwave absorption, which has a minimum at zero magnetic field and increases with the applied magnetic field.

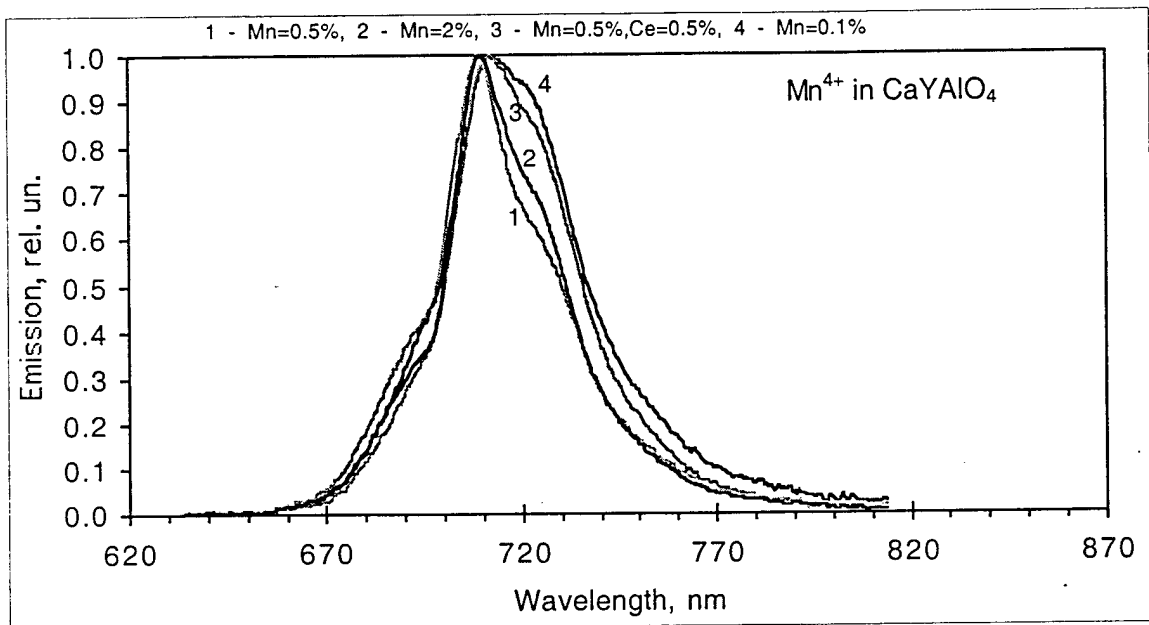

Fig. 2. Emission spectra in manganese doped $CaYAlO_4$. 1 - Mn=0.5%, 2 - Mn=2%, 3 - Mn=0.5%, Ce=0.5%, 4 - Mn=0.1%.

Although as grown $Mn:CaYAlO_4$ crystal had some concentration of Mn^{5+} ions, photoinduced coloration and photoionization of Mn^{4+} to Mn^{5+} was not found in this material. This makes it useless for optical data storage applications. However, an intensive broad-band Mn^{4+} luminescence and reasonably long life-time of the metastable state make the crystal potentially interesting for laser applications.

F. ORGANIZATION AND PARTICIPATION

Due to the fact that Co-P.I from Alabama A&M University, Dr. M.A. Noginov, and Dr. Noginova had moved to Norfolk State University before the effective date of the project, most of the work has been done at NSU. The following faculty and staff, members of the Center for Materials Research have been taking part in the project:

George B. Loutts – overall leadership, crystal growth, x-ray diffractometry, modeling;

Mikhail A. Noginov – optical spectroscopy, diffraction experiments, modeling;

Rakhim R. Rakhimov – EPR spectroscopy;

Heidi R. Ries – EPR spectroscopy, management;

Natalia Noginova – diffraction experiments, NMR;

Patrick Higgins – technical support.

The following students participated in the research at NSU:

Walter Lindsey (Materials Science graduate)

Amy Wilkerson (Materials Science graduate)

Matthew Warren (Physics major)

Rosalind Wynne (Physics major)

Brooke Lasley (Physics major)

David Jones (Physics major)

B. Lucas (Physics major)

D. Fider (Physics major)

Kai Ross (Summer intern)

Talia Grandy (Summer intern)

Justin Tansuwan (Summer intern)

Sturks Taylor (Materials Science graduate) has been supported by the grant.

Consulting support on photorefractive behavior and diffraction experiments has been provided by Nikolai Kukhtarev from Alabama A&M University. The following tasks have been performed by Claud Martin of Adams-Brown Services, Inc.: planning and procurement support, CADD and fabrication of components, data analysis and test support. Roger Macfarlane and Robert Shelby from IBM Almaden Research Center, Almaden, CA conducted holographic recording tests and comparison of Mn:YAlO₃ with commercial holographic materials. P.P. Benergee and M. Morissey from University of Alabama in Huntsville, Huntsville, AL made measurements with the z-scan technique. Some interferometric measurements were done by Richard Linke from NEC Research Institute, Princeton, NJ. Hans Jenssen from CREOL, University of Central Florida, Orlando, FL oriented single crystalline samples using the Laue technique. Stephen Kück from, Hamburg University, Germany participated in the optical spectroscopy measurements and analysis of Mn⁵⁺ ions in YAlO₃.

APPENDIX A

PUBLICATIONS, PRESENTATIONS AND STUDENT REPORTS

A1. Papers In Referred Journals

1. R. R. Rakhimov, A. L. Wilkerson, G. B. Loutts, M. A. Noginov, N. Noginova, W. Lindsay, H. R. Ries. Spin and valence states of manganese ions in manganese-doped yttrium orthoaluminate, *Solid State Communications*, **108**, 1998, 549-554.
2. M.A. Noginov, G.B. Loutts, Spectroscopic studies of Mn^{4+} ions in yttrium orthoaluminate, *Journal of Optical Society of America B*, **16**, 1999, 3-11.
3. M.A. Noginov, G.B. Loutts, M. Warren, Spectroscopic studies of Mn^{3+} and Mn^{2+} ions in $YAlO_3$, *Journal of Optical Society of America B*, **16**, 1999, 475-483.
4. N. Noginova, W. Lindsay, M.A. Noginov, G.B. Loutts, L. Mattix, Photorefractive effects in Mn doped $YAlO_3$, *Journal of Optical Society of America B*, **16**, 1999, 754-756.
5. M.A. Noginov, G.B. Loutts, N. Noginova, S. Hurling, S. Kuck, Spectroscopic characterization of photoinduced Mn^{5+} ions in $YAlO_3$, *Physical Review B*, **61**, 2000, 1884-1891.
6. N. Noginova, L. Mattix, G.B. Loutts, V.A. Atsarkin, NMR study of holographic Mn-doped yttrium orthoaluminates, *Applied Magnetic Resonance*, **18**, 2000, 267-274.
7. M.A. Noginov, G.B. Loutts, K. Ross, T. Grandy, N. Noginova, B. Lucas, T. Mapp. The role of traps in photocoloration of Mn: $YAlO_3$. Submitted to *JOSA B*, August 2000.

A2. Presentations at Scientific Conferences

1. R.R. Rakhimov, A.L. Wilkerson, W. Lindsay, N. Noginova, G.B. Loutts, M.A. Noginov, H.R. Ries, Spin states of manganese ions in manganese-doped yttrium orthoaluminate, 21th International EPR Symposium, July 26-30, 1998, Denver, Colorado.
2. M.A. Noginov, G.B. Loutts, N. Noginova, C. Jackson, H.J. Caulfield, N. Kukhtarev, Optical studies of Mn: $YAlO_3$, promising material for holographic recording and optical storage, XVI International Conference on Coherent and Nonlinear Optics, June 29-July 3, 1998, Moscow, Russia, Technical Digest, paper FE3.

3. G.B. Loutts, M.A. Noginov, R.R. Rakhimov, M. Warren, N. Noginova, H. Ries, Photoinduced color centers in a series of manganese doped rare-earth orthoaluminates, *ibid*, paper ThU26.
4. M.A. Noginov, G.B. Loutts, N. Noginova, M. Warren, C. Jackson, C. Bonner, R. Rakhimov, H. Ries, Spectroscopic characterization of Mn:YAlO₃, material for holographic recording and optical data storage, European Conference on Lasers and Electro-Optics, September 13-18, 1998, Glasgow, Scotland.
5. G.B. Loutts, M.A. Noginov, R. Wynne, Crystal growth and characterization of manganese doped orthoaluminates capable of photorefractive effect, Eastern Regional Conference on Crystal Growth & Epitaxy, ACCGE/east-98, September 27-30, 1998, Atlantic City, New Jersey.
6. G.B. Loutts, M.A. Noginov, R.R. Rakhimov, R.M. Wynne, C. Jackson, H.R. Ries, Photoinduced disproportionation reaction in manganese-doped aluminates, 1998 OSA Annual Meeting, October 4-9, Baltimore, Maryland, paper TuW3..
7. N. Noginova, W Lindsay, G. Loutts, M.A. Noginov, N. Kukhtarev, Photorefractive properties of Mn:YAlO₃ crystals, *ibid*, paper FR3.
8. G.B. Loutts, M.A. Noginov, R. Wynne, K.T. Ross, T. Grandy, Investigation of thermal bleaching in manganese doped orthoaluminate single crystals, 13th Annual National Educators' Workshop: Update 98. Standard experiments in engineering, materials science and technology. Brookhaven National Laboratory, Long Island, NY, November 1-4, 1998.
9. M.A. Noginov, M. Warren, G.B. Loutts, X-ray excited emission of Mn²⁺ ions in Mn:YAlO₃, *Ibid*.
10. N. Noginova, M.A. Noginov, W. Lindsay, G.B. Loutts, Long term holographic recording in Mn doped aluminates, Abstracts of MRS 1998 Fall Meeting, November 30 – December 4, Boston, MA, paper T2.7, p. 414.
11. N. Noginova, L. Mattix, G. B. Loutts, V. A. Atsarkin. NMR study of Mn doped yttrium orthoaluminates. 1999 Centennial Meeting Bulletin of the American Physical Society, March 20-26, 1999, Atlanta, Georgia. Vol. 44, No.1, p.366. Abstract number GP01 122.
12. M.A. Noginov, G.B. Loutts, K. Ross, T. Grandy, N. Noginova, B. Lucas, T. Mapp, The role of traps and the balance of manganese valence states in Mn:YAlO₃, a material for holographic recording and optical data storage, *ibid*, paper CWO6.
13. M.A. Noginov, G.B. Loutts, K.T. Ross, T. Grandy, B. Lucas, T. Mapp, The role of traps in photocoloration, holographic recording, and optical data storage in

Mn:YAlO₃, International Conference on Luminescence and Optical Spectroscopy of Condensed Matter, Osaka, Japan, August 1999, paper BO8-2, p. 287.

14. M.A. Noginov, G.B. Loutts, N. Noginova, Observation of Mn⁵⁺ ions in octahedral coordination in perovskites, *ibid*, paper PD3-3, p. 286.
15. G.B. Loutts, M.A. Noginov, N. noginova, R.M. Wynne, K.T. Ross, T. Grandy, Crystal growth and optical characterization of manganese doped aluminate crystals, *ibid*, paper BO5-5, p. 188.
16. M. A. Noginov, N. Noginova, G. B. Loutts, K. Babalola, R. R. Rakhimov, Spectroscopic studies of manganese doped LaGaO₃ crystals, MRS Meeting, Boston, MA, December 1999.
17. M. A. Noginov, G. B. Loutts, P.P. Banerjee, M. Morrisey, R. A. Linke, Studies of local and non-local components in photorefractive response in Mn:YAlO₃, in Conference on Lasers and Electro-Optics, San-Francisco, May 2000, OSA Technical Digest (Optical Society of America, Washington, DC, 2000) pp. 6-7.
18. M. A. Noginov, G. B. Loutts, B. Lucas, D. Fider, R. M. Macfarlane, R. M. Shelby, Two-color holographic recording scheme allowing non-volatile recording in Mn:YAlO₃, *ibid*, p. 7.
19. B. D. Lucas, D. Fider, B. A. Lasley, D. Jones, G. B. Loutts, R. R. Rakhimov, M. A. Noginov, Crystal growth and spectroscopic study of manganese doped CaYAlO₄, *ibid*, p. 387.

A3. Student Theses

1. Matthew E. Warren, "Identification of manganese valence states by optical spectroscopy in manganese doped yttrium orthoaluminate", Senior Thesis in Submission for Requirement of Bachelor's of Science Degree in Physics, Norfolk State University, April 1998.
2. Amy L. Wilkerson, "Investigation of chromium and manganese doped yttrium aluminum oxides using electron paramagnetic resonance". M. S. Thesis, Norfolk State University, May 16, 1999.
3. Walter Lindsey, "The effect of illumination on optical properties of Mn:YAlO₃", 1999.
4. Brooke A. Lasley, "Electron paramagnetic resonance investigation of Mn-doped CaYAlO₄". B. S. Thesis, Norfolk State University, April 28, 2000.

5. David E. Jones, "Microwave response near zero magnetic field in Mn-doped yttrium aluminates". B. S. Thesis, Norfolk State University, April 28, 2000.