

ARMY RESEARCH LABORATORY



# An Analytic Description of a Harmonic Decomposition Technique for Correcting Signal Errors Due to Wideband Radar Phase Detector

Thomas J. Pizzillo and Jerry Silvius

ARL-TR-2306

November 2000

Approved for public release; distribution unlimited.

20001229 020

The findings in this report are not to be construed as an official Department of the Army position unless so designated by other authorized documents.

Citation of manufacturer's or trade names does not constitute an official endorsement or approval of the use thereof.

Destroy this report when it is no longer needed. Do not return it to the originator.

# Army Research Laboratory

Adelphi, MD 20783-1197

---

ARL-TR-2306

November 2000

## An Analytic Description of a Harmonic Decomposition Technique for Correcting Signal Errors Due to Wideband Radar Phase Detector

Thomas J. Pizzillo and Jerry Silvious  
Sensors and Electron Devices Directorate

---

## Abstract

---

A signal processing technique is presented for correcting imbalances and distortions introduced to the signals by the phase detectors of a coherent wideband radar. The signal model and sources of signal errors are described, an analytic description of how the corrections are derived is provided, and a sample application is presented with the use of simulated data. This report has been prepared in anticipation of a subsequent report in which the performance of this signal processing technique will be compared with the performances of several other techniques developed for similar purposes with actual data measured in the field.

---

## Contents

---

1	Introduction	1
2	Derivation of Correction Terms	2
3	Technique Application	5
4	Conclusion	7
	Distribution	9
	Report Documentation Page	13

## Figures

1	Simplified block diagram of a monopulse radar . . . . .	2
2	Simplified block diagram of IF section of a monopulse radar . .	3
3	Simplified block diagram of rf section of a monopulse radar . .	5
4	Simulated I/Q data: Squares indicate measured data and circles indicate corrected data . . . . .	6

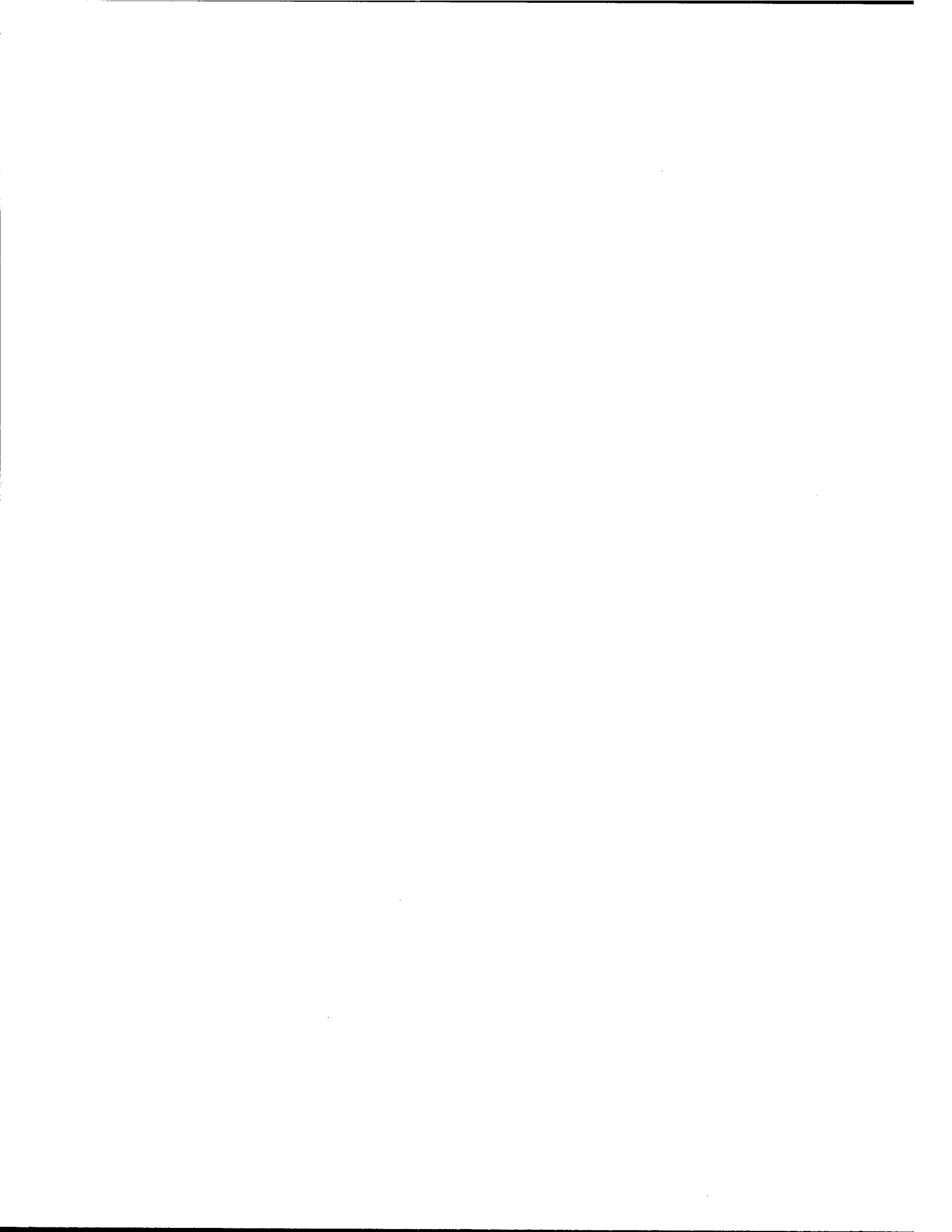

---

## 1. Introduction

---

The U.S. Army Research Laboratory (ARL) has a variety of instrumentation radars for research related to sensor technologies, to include modeling, simulation, analysis, and signal processing of radar signatures. Before any of these research objectives are met, the data collected by the instrumentation radars must be calibrated to relate the returned signal to the transmitted signal. This calibration removes errors introduced by components of the radar and scales the data. In particular, ARL's Millimeter-Wave Branch of the Radio Frequency (rf) and Electronics Division has several inverse synthetic aperture radars containing phase detectors that require error correction. As these new radars are developed and introduced, new calibration techniques have been developed so that three distinct techniques are now being used. Two of these techniques, the method of Wallace and Pizzillo<sup>1</sup> and a phase modulation and demodulation technique,<sup>2</sup> have been documented as ARL technical reports. The third, a harmonic decomposition technique, has only been documented as an algorithm in software.

This report provides an analytic description of the third algorithm in anticipation of publishing a report detailing a comparison of the three techniques with the use of data collected by the state-of-the-art 35-GHz monopulse instrumentation radar. This instrument uses the phase modulation and demodulation technique, an architecture-based calibration, and the only one of the various radars that can collect data that may be corrected by all three techniques, thereby allowing a direct comparison of the efficiency and accuracy of each scheme.

---

<sup>1</sup>H. Bruce Wallace and Thomas J. Pizzillo, *A Technique for Calibrating the Phase Detector of a Wideband Radar Using an External Target*, U.S. Army Research Laboratory, ARL-TR-1521 (March 1998).

<sup>2</sup>Thomas J. Pizzillo and H. Bruce Wallace, *A Technique for Calibrating the Phase Detector of Wideband Radars Using a Phase Modulation and Demodulation Scheme*, U.S. Army Research Laboratory, ARL-TR-1567 (May 1998).

## 2. Derivation of Correction Terms

Figure 1 is a simplified block diagram of a polarimetric, two-coordinate, amplitude-comparison monopulse system operating at 94 GHz, with a 640-MHz bandwidth. Either linearly or circularly polarized radiation is transmitted and both components are received, i.e., left-circular transmit and right- and left-circular receive or vertical transmit and vertical and horizontal receive. Transmit polarization may be changed to pulse to pulse or ramp to ramp.

The rf local oscillator (LO) is frequency-stepped synchronously with the transmitter and maintains a constant 3-GHz offset. This source is mixed with the received signal to provide the 3-GHz intermediate frequency (IF) to the in-phase/quadrature (I/Q) detectors. The IF is mixed with the 3-GHz LO to provide the final direct current (DC) signal to the analog-to-digital converter (ADC). The 3-GHz LO is also the source of the injected test signal used for correcting the phase and gain imbalances introduced by the I/Q detectors. A simplified block diagram of the IF section is shown in figure 2. This test signal is

$$S = A \cos 2\pi f , \quad (1)$$

where  $f$  represents the test signal's constant frequency and  $A$  is the amplitude of the test signal. However, this only provides a single DC output

Figure 1. Simplified block diagram of a monopulse radar.

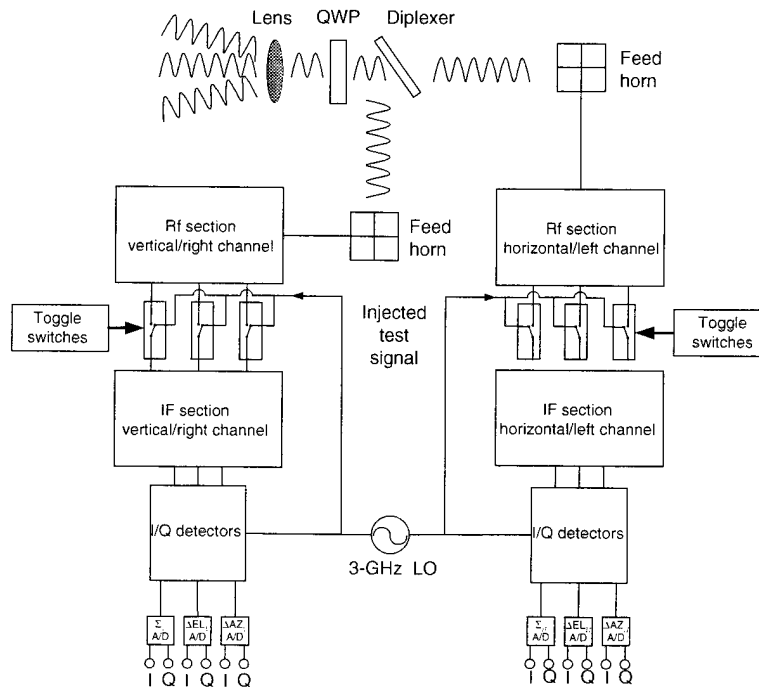
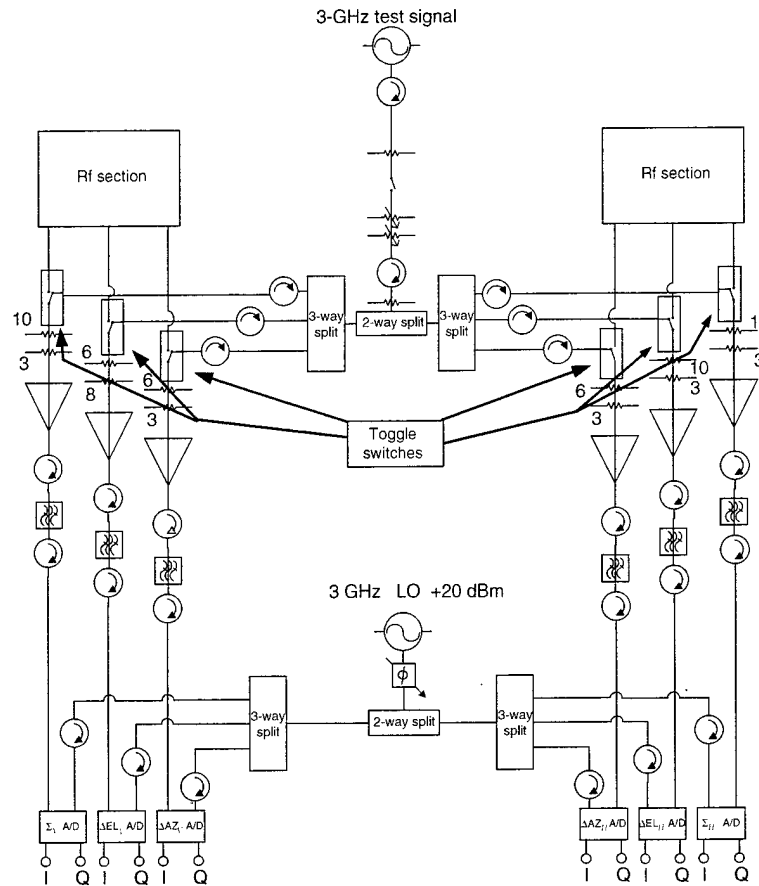

Figure 2. Simplified block diagram of IF section of a monopulse radar.



value for a given frequency from the I/Q detectors, and correcting the output of the detectors over a range of frequencies is necessary. To accomplish this, one must phase-modulate the test signal to provide an input to the I/Q detectors as

$$S(m) = A \cos \left( 2\pi f + 2\pi \frac{m}{M} \right), \quad (2)$$

where  $M$  is an even integer representing the number of phase modulation steps. Shifting the phase creates a pseudo-time-sampled signal with frequency of 1 Hz and a period of  $1/M$ . This signal is injected at the IF section and then propagates through the phase detector, where a second signal, shifted  $90^\circ$  relative to the test signal, is generated. These signals are referred to as the I and Q channels of the detector:

$$\begin{aligned} I(m) &= A \cos \left( 2\pi \frac{m}{M} \right) + V_i \quad \text{and} \\ Q(m) &= GA \sin \left( 2\pi \frac{m}{M} + \delta \right) + V_q, \end{aligned} \quad (3)$$

where  $V_i$  and  $V_q$  are DC-offsets and  $G$  and  $\delta$  represent the relative gain and phase imbalances between the outputs of I and Q channels, all introduced by the imperfect detector. The  $2\pi f$  term has been eliminated because the detection is a mixing process with  $f$  as the baseband. At this juncture, these

errors could be corrected by the method described in Wallace and Pizzillo. However, in addition to the errors introduced by the phase detector, the components that compose the IF section cause nonlinear distortion of the signal so that the signals may be better modeled by a set of trigonometric polynomials,

$$\begin{aligned}\mathbf{I}(M) &= \sum_{n=0}^N A_n \cos\left(2n\pi \frac{m}{M}\right) + V_i \quad N = 0, 2, 4, \dots, \frac{M}{2} \\ \mathbf{Q}(M) &= \sum_{n=0}^N B_n \sin\left(2n\pi \frac{m}{M}\right) + V_q \quad N = 1, 3, 5, \dots, \left(\frac{M}{2} - 1\right).\end{aligned}\quad (4)$$

Although the phase and gain imbalance of the phase detector creates a response at the image range bin,<sup>3</sup> this error is subsumed by the appropriate terms and coefficients of the polynomial and needs not be explicitly enumerated. Equation (4) represents a set of functions orthogonal on the complex plane over the range  $[-\pi, \pi]$ . Hence, the coefficients  $A_n$  and  $B_n$  may be determined via the complex fast Fourier transform (CFFT) of the measured I/Q detector outputs by

$$\begin{aligned}F[\mathbf{I}(M), \mathbf{Q}(M)] &= \sum_{n=0}^N \left\{ A_n \cos\left(2n\pi \frac{m}{M}\right) + iB_n \sin\left(2n\pi \frac{m}{M}\right) + V \right\} \exp\left(2\pi j \frac{k}{M}\right) \\ &= \mathbf{I}(K) + i\mathbf{Q}(K),\end{aligned}\quad (5)$$

where  $V = V_i + V_q$  and  $\mathbf{I}(K)$  and  $\mathbf{Q}(K)$  are the  $M$  outputs of the CFFT that represent the harmonic coefficients of the transformed signal. That is, for each  $k$ , only the trigonometric component  $k = n$  contributes

$$\begin{aligned}\mathbf{I}(K) &= A_0 + A_2 \cos\left(2\pi \frac{2}{M}\right) + \dots + A_{M-2} \cos\left(2\pi \frac{M-2}{M}\right), \quad \text{and} \\ \mathbf{Q}(K) &= B_1 \sin\left(2\pi \frac{1}{M}\right) + B_3 \sin\left(2\pi \frac{3}{M}\right) + \dots + B_{\frac{M-2}{2}} \sin\left(2\pi \frac{M-2}{2M}\right).\end{aligned}\quad (6)$$

The maximum number of contributing harmonics is determined by the Nyquist rate or  $M/2$  distributed symmetrically about the fundamental:

$$\begin{aligned}\mathbf{I}(K) &= A_0 + A_{\frac{-M}{2}} \cos(-\pi) + \dots + A_{\frac{M}{2}} \cos(\pi), \quad \text{and} \\ \mathbf{Q}(K) &= B_{\frac{2-M}{2}} \sin\left(2\pi \frac{2-M}{2M}\right) + \dots + B_{\frac{M-2}{2}} \sin\left(2\pi \frac{M-2}{2M}\right).\end{aligned}\quad (7)$$

By repeating this procedure for several amplitudes and storing the values in a lookup table, one may correct any measured amplitude on the complex plane defined by  $\mathbf{I}$  and  $\mathbf{Q}$  up to the maximum calibration amplitude.

<sup>3</sup>Merril Skolnik, *Radar Handbook*, 2nd ed., McGraw-Hill, Inc. (1990), p 3.41.

### 3. Technique Application

The correction noted in section 2 is applied in the following procedure: A constant amplitude signal is injected into the IF section of the radar via the toggle switches (see fig. 2). This provides a DC signal to the ADC. Data are collected at 16 phase angles,  $22.5^\circ m$ , where  $m = 0, 1, \dots, 15$ , controlled by the phase-shifter shown in figure 3 for both the I and Q channels. Six thousand four hundred samples are averaged for each phase setting to minimize noise. The data are converted to signed integer values by subtracting half the dynamic range of the ADC from each set, i.e., 2048. A complex value is generated from the I and Q data and then sorted from the minimum to maximum phase. This process is repeated for four attenuation levels: 98, 78, 58, and 39 percent of the A/D dynamic range, i.e., 4095. The final results are four sets of complex data of 16 values each from which the correction coefficients are derived.

The correction coefficients are used to correct measured data in both phase and amplitude by subtracting the unwanted harmonic components from each measured data point,  $I_m$  and  $Q_m$ . Measured amplitudes are corrected with the correction amplitudes above and below the measured value, with

Figure 3. Simplified block diagram of rf section of a monopulse radar.

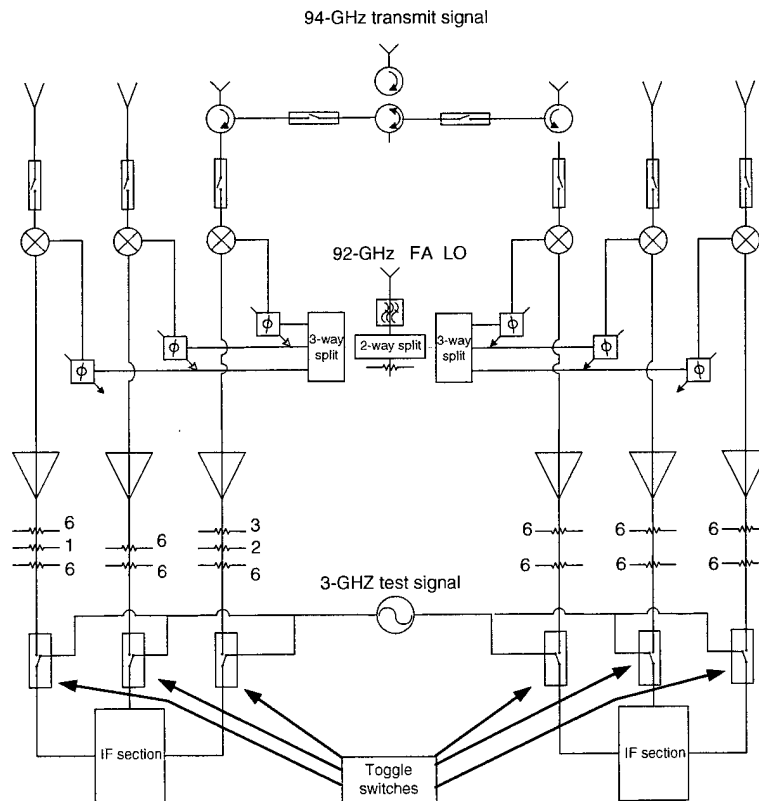

an appropriate weighting factor. This weighting factor is calculated with

$$W_u = \frac{(A_u - A_m)}{(A_u - A_l)} \quad W_l = \frac{(A_m - A_l)}{(A_u - A_l)}; \quad (W_u + W_l = 1) . \quad (8)$$

where  $A_u$  is the correction amplitude greater than the measured value,  $A_l$  is the correction amplitude less than the measured value, and  $A_m = \sqrt{I_m^2 + Q_m^2}$  = the amplitude of the measured  $I$  and  $Q$  data points.

Consider the simulated data in figure 4 created for  $M = 16$ . The set of measured I/Q pairs is indicated with squares and falls between the calibration amplitudes,  $A_u = 1500$  and  $A_l = 1200$ . The corrected  $I$  and  $Q$  values are determined by

$$\begin{aligned} I_c &= I_m - W_u [A_{0u} + A_{-8u} \cos(-8\theta_m) + \dots + A_{8u} \cos(8\theta_m)] \\ &\quad - W_l [A_{0l} + A_{-8l} \cos(-8\theta_m) + \dots + A_{8l} \cos(8\theta_m)] , \quad \text{and} \\ Q_c &= Q_m - W_u [A_{-7u} \sin(-7\theta_m) + \dots + A_{7u} \sin(7\theta_m)] \\ &\quad - W_l [A_{-7l} \sin(-7\theta_m) + \dots + A_{7l} \sin(7\theta_m)] . \end{aligned} \quad (9)$$

where  $I_c$  and  $Q_c$  are the corrected  $I$  and  $Q$  data points.  $\theta_m = \arctan 2 \left( \frac{Q_m}{I_m} \right)$  is the measured relative phase between  $I_m$  and  $Q_m$ .  $A_{nu}$  and  $A_{nl}$  are the  $n$ th harmonic coefficient for the upper and lower calibration bounds, respectively. These expressions are applied to each of the 16 I/Q pairs indicated with circles in figure 4. This example is for demonstration only and for clarifying the application of this technique. A subsequent report will compare the application of this technique to measured data, and its performance will be compared with two other techniques developed for the same data correction problem.

Figure 4. Simulated I/Q data: Squares indicate measured data and circles indicate corrected data.

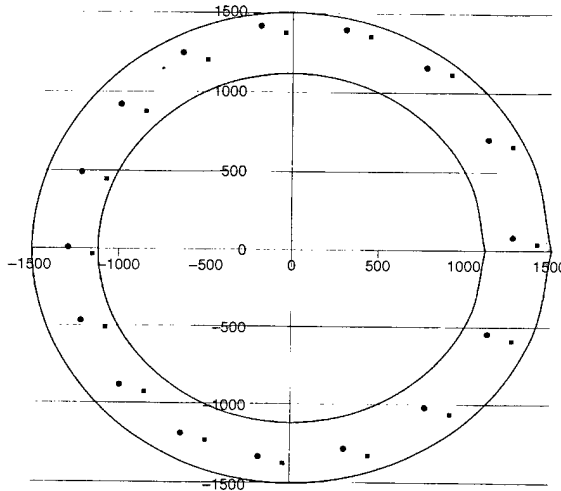

---

## 4. Conclusion

---

An algorithm currently used by ARL (Millimeter-Wave Branch) for correcting the I and Q errors introduced by the phase detectors of a wideband radar has been presented. The signals with errors have been modeled as trigonometric polynomials and the correction described as a harmonic decomposition based upon the CFFT. An analysis of the performance of this technique is left for a subsequent publication in which the performance of the two other techniques (see sect. 1) will be compared along with the results of this harmonic decomposition as applied to actual measured data from a state-of-the-art 35-GHz monopulse instrumentation radar.



## Distribution

Admnstr  
Defns Techl Info Ctr  
Attn DTIC-OCP  
8725 John J Kingman Rd Ste 0944  
FT Belvoir VA 22060-6218

DARPA  
Attn S Welby  
Attn Techl Lib  
3701 N Fairfax Dr  
Arlington VA 22203-1714

Ofc of the Secy of Defns  
Attn ODDRE (R&AT)  
The Pentagon  
Washington DC 20301-3080

Ofc of the Secy of Defns  
Attn OUSD(A&T)/ODDR&E(R) R J Trew  
3080 Defense Pentagon  
Washington DC 20301-7100

Under Secy of Defns for Rsrch & Engrg  
Attn Rsrch & Advncd Techlgy  
Dept of Defns  
Washington DC 20301

AMCOM MRDEC  
Attn AMSMI-RD W C McCorkle  
Redstone Arsenal AL 35898-5240

CECOM NVESD  
Attn AMSEL-RD-NV-ASD M Kelley  
Attn AMSEL-RD-NV-TISD F Petito  
FT Belvoir VA 22060

Dir for MANPRINT  
Ofc of the Deputy Chief of Staff for Prsnl  
Attn J Hiller  
The Pentagon Rm 2C733  
Washington DC 20301-0300

NGIC  
Attn IANG RSC S Carter  
220 7th Stret NE  
Charlottesville VA 22902-5396

SMC/CZA  
2435 Vela Way Ste 1613  
El Segundo CA 90245-5500

US Army ARDEC  
Attn AMSTA-AR-TD M Fisette  
Attn SMCAR-FSP-A1 M Rosenbluth  
Attn SMCAR-FSP-A1 R Collett  
Bldg 1  
Picatinny Arsenal NJ 07806-5000

US Army CECOM NVESD  
Attn AMSEL-RD-NV-RSPO A Tarbell  
Mailstop 1112  
FT Monmouth NJ 07703-5000

US Army CECOM RDEC  
Night Vsn & Elect Sensors Dirctr  
Attn AMSEL-RD-NV-OD F Milton  
10221 Burbeck Rd Ste 430  
FT Belvoir VA 22060-5806

US Army CRREL  
Attn G D Ashton  
Attn SWOE G Koenig  
Attn SWOE P Welsh  
72 Lyme Rd  
Hanover NH 03755-1290

US Army Info Sys Engrg Cmnd  
Attn AMSEL-IE-TD F Jenia  
FT Huachuca AZ 85613-5300

US Army Missile Lab  
Attn AMSMI-RD Advanced Sensors Dir  
Attn AMSMI-RD Sys Simulation & Dev Dir  
Attn AMSMI-RD-AS-MM H Green  
Attn AMSMI-RD-AS-MM M Christian  
Attn AMSMI-RD-AS-MM M Mullins  
Attn AMSMI-RD-AS-MM W Garner  
Attn AMSMI-RD-AS-RPR Redstone Sci Info  
Ctr  
Attn AMSMI-RD-AS-RPT Techl Info Div  
Attn AMSMI-RD-SS-HW S Mobley  
Attn AMSMI-RD-MG-RF G Emmons  
Redstone Arsenal AL 35809

US Army Natick RDEC Acting Techl Dir  
Attn SBCN-T P Brandler  
Natick MA 01760-5002

## Distribution (cont'd)

US Army Simulation, Train, & Instrmntn  
Cmnd

Attn AMSTI-CG M Macedonia  
Attn J Stahl  
12350 Research Parkway  
Orlando FL 32826-3726

US Army Soldier & Biol Chem Cmnd  
Dir of Rsrch & Techlgy Dirctr  
Attn SMCCR-RS I G Resnick  
Aberdeen Proving Ground MD 21010-5423

US Army Tank-Automtv Cmnd Rsrch, Dev, &  
Engrg Ctr  
Attn AMSTA-TR J Chapin  
Warren MI 48397-5000

US Army Test & Eval Cmnd  
Attn STEWS-TE-AF F Moreno  
Attn STEWS-TE-LG S Dickerson  
White Sands Missile Range NM 88002

US Army Train & Doctrine Cmnd  
Battle Lab Integration & Techl Dirctr  
Attn ATCD-B  
Attn ATCD-B J A Klevecz  
FT Monroe VA 23651-5850

US Military Academy  
Mathematical Sci Ctr of Excellence  
Attn MADN-MATH MAJ R Huber  
Thayer Hall  
West Point NY 10996-1786

USAE Waterways Exprmnt Sta  
Attn CEWES-EE-S J Curtis  
Attn CEWES-EN-C W West  
3909 Halls Ferry Rd  
Vicksburg MS 39180-6199

USATEC  
Attn J N Rinker  
Attn P Johnson  
7701 Telegraph Rd  
Alexandria VA 22315-3864

Nav Rsrch Lab  
Attn 2600 Techl Info Div  
4555 Overlook Ave SW  
Washington DC 20375

Nav Surface Warfare Ctr  
Attn Code B07 J Pennella  
17320 Dahlgren Rd Bldg 1470 Rm 1101  
Dahlgren VA 22448-5100

Nav Weapons Ctr  
Attn 38 Rsrch Dept  
Attn 381 Physics Div  
China Lake CA 93555

AFMC Rome LAB/OC 1  
Attn J Bruder  
Griffiss AFB NY 13441-4314

Eglin Air Force Base  
Attn 46 TW/TSWM B Parnell  
211 W Eglin Blvd Ste 128  
Eglin AFB FL 32542-5000

USAF Wright Lab  
Attn WL/MMGS B Sundstrum  
Attn WL/MMGS R Smith  
101 W Eglin Blvd Ste 287A  
Eglin AFB FL 32542-6810

Sandia Natl Lab  
PO Box 5800  
Albuquerque NM 87185

Eviron Rsrch Inst of MI  
Attn C L Arnold  
PO Box 134001  
Ann Arbor MI 48113-4001

Georgia Inst of Techlgy  
Georgia Tech Rsrch Inst  
Attn Radar & Instrmntn Lab N C Currie  
Attn Radar & Instrmntn Lab R McMillan  
Attn Radar & Instrmntn Lab T L Lane  
Atlanta GA 30332

Ohio State Univ  
Elect Sci Lab  
Attn R J Marhefka  
Columbus OH 43212

Univ of Michigan  
Radiation Lab  
Attn F Ulaby

## Distribution (cont'd)

Univ of Michigan (cont'd)

Attn K Sarabandi  
3228 EECS Bldg 1301 Beal Ave  
Ann Arbor MI 48109-2122

VA Polytechnic Inst & State Univ  
Elect Interaction Lab  
Attn G S Brown  
Bradley Dept of Elect Engrg  
Blacksburg VA 24061-0111

Hicks & Associates Inc  
Attn G Singley III  
1710 Goodrich Dr Ste 1300  
McLean VA 22102

Lockheed Martin Corp Elect & Missile Div  
Attn E Weatherwax  
5600 Sand Lake Rd Mail Stop 450  
Orlando FL 32819

Minister of Defense  
Attn A Priou  
Paris 22333  
France

MIT Lincoln Lab  
Attn E Austin  
Attn W Keicher  
PO Box 73  
Lexington MA 02173-9108

Palisades Inst for Rsrch Svc Inc  
Attn E Carr  
1745 Jefferson Davis Hwy Ste 500  
Arlington VA 22202-3402

Simulation Techl  
Attn A V Saylor  
Attn D P Barr  
3307 Bob Wallace Ave SW 4  
Huntsville AL 35805-4066

US Army Rsrch Lab  
Attn AMSRL-SE-RM R Bender  
Attn AMSRL-SE-RM R Tan  
Attn AMSRL-SE-RM S Stratton  
Attn AMSRL-WM-BA R A McGee  
Aberdeen Proving Ground MD 21005

Director

US Army Rsrch Ofc  
Attn AMSRL-RO-D JCI Chang  
Attn B D Guenther  
Attn C Church  
PO Box 12211  
Research Triangle Park NC 27709

US Army Rsrch Lab  
Attn AMSRL-DD J M Miller  
Attn AMSRL-CI-AI-R Mail & Records Mgmt  
Attn AMSRL-CI-AP Techl Pub (3 copies)  
Attn AMSRL-CI-LL Techl Lib (3 copies)  
Attn AMSRL-SE J Pellegrino  
Attn AMSRL-SE-D E Scannell  
Attn AMSRL-SE-E D Wilmot  
Attn AMSRL-SE-EE Z G Sztankay  
Attn AMSRL-SE-R B Wallace  
Attn AMSRL-SE-RM C Ly  
Attn AMSRL-SE-RM D Hutchins  
Attn AMSRL-SE-RM D W Vance  
Attn AMSRL-SE-RM D Wikner  
Attn AMSRL-SE-RM E Adler  
Attn AMSRL-SE-RM E Burke  
Attn AMSRL-SE-RM G Goldman  
Attn AMSRL-SE-RM H Dropkin  
Attn AMSRL-SE-RM J Clark  
Attn AMSRL-SE-RM J Nemarich  
Attn AMSRL-SE-RM J Silverstein  
Attn AMSRL-SE-RM J Silvious  
Attn AMSRL-SE-RM J Speulstra  
Attn AMSRL-SE-RM K Tom  
Attn AMSRL-SE-RM R Dahlstrom  
Attn AMSRL-SE-RM R Harris  
Attn AMSRL-SE-RM R Wellman  
Attn AMSRL-SE-RM T Pizzillo (10 copies)  
Attn AMSRL-SE-RM W Wiebach  
Attn AMSRL-SE-RU B Scheiner  
Attn AMSRL-SE-RU J Sichina  
Adelphi MD 20783-1197

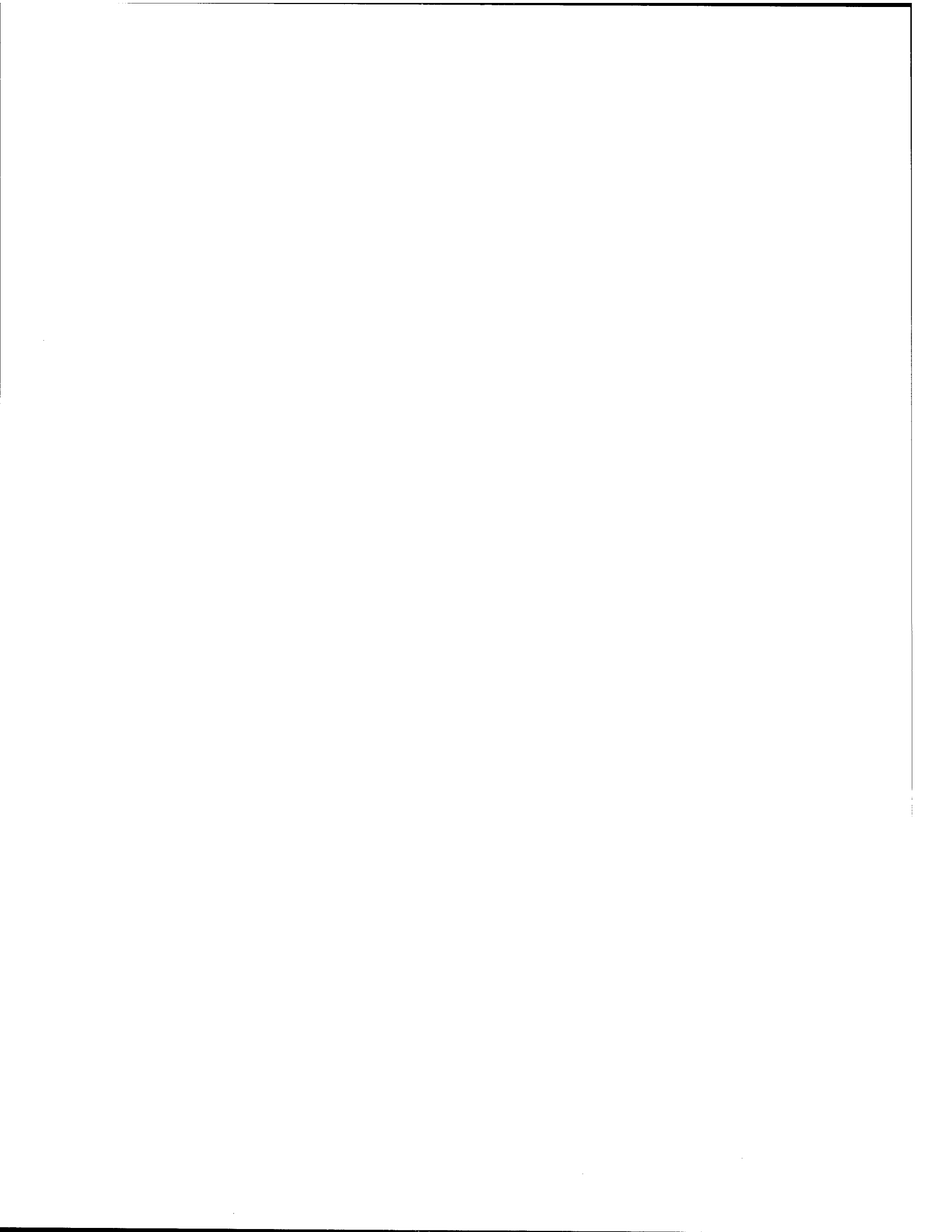

# REPORT DOCUMENTATION PAGE

Form Approved  
OMB No. 0704-0188

Public reporting burden for this collection of information is estimated to average 1 hour per response, including the time for reviewing instructions, searching existing data sources, gathering and maintaining the data needed, and completing and reviewing the collection of information. Send comments regarding this burden estimate or any other aspect of this collection of information, including suggestions for reducing this burden, to Washington Headquarters Services, Directorate for Information Operations and Reports, 1215 Jefferson Davis Highway, Suite 1204, Arlington, VA 22202-4302, and to the Office of Management and Budget, Paperwork Reduction Project (0704-0188), Washington, DC 20503.

1. AGENCY USE ONLY (Leave blank)		2. REPORT DATE November 2000	3. REPORT TYPE AND DATES COVERED Final, April-June 2000
4. TITLE AND SUBTITLE An Analytic Description of a Harmonic Decomposition Technique for Correcting Signal Errors Due to Wideband Radar Phase Detector			5. FUNDING NUMBERS DA PR: AH16 PE: 62120A
6. AUTHOR(S) Thomas J. Pizzillo and Jerry Silvius			
7. PERFORMING ORGANIZATION NAME(S) AND ADDRESS(ES) U.S. Army Research Laboratory Attn: AMSRL-SE-RM email: pizzillo@arl.army.mil 2800 Powder Mill Road Adelphi, MD 20783-1197			8. PERFORMING ORGANIZATION REPORT NUMBER ARL-TR-2306
9. SPONSORING/MONITORING AGENCY NAME(S) AND ADDRESS(ES) U.S. Army Research Laboratory 2800 Powder Mill Road Adelphi, MD 20783-1197			10. SPONSORING/MONITORING AGENCY REPORT NUMBER
11. SUPPLEMENTARY NOTES ARL PR: ONE4H1 AMS code: 622120.H16			
12a. DISTRIBUTION/AVAILABILITY STATEMENT Approved for public release; distribution unlimited.			12b. DISTRIBUTION CODE
13. ABSTRACT (Maximum 200 words) A signal processing technique is presented for correcting imbalances and distortions introduced to the signals by the phase detectors of a coherent wideband radar. The signal model and sources of signal errors are described, an analytic description of how the corrections are derived is provided, and a sample application is presented with the use of simulated data. This report has been prepared in anticipation of a subsequent report in which the performance of this signal processing technique will be compared with the performances of several other techniques developed for similar purposes with actual data measured in the field.			
14. SUBJECT TERMS Error correction, imbalance			15. NUMBER OF PAGES 16
			16. PRICE CODE
17. SECURITY CLASSIFICATION OF REPORT Unclassified	18. SECURITY CLASSIFICATION OF THIS PAGE Unclassified	19. SECURITY CLASSIFICATION OF ABSTRACT Unclassified	20. LIMITATION OF ABSTRACT UL