

REPORT DOCUMENTATION PAGE			Form Approved OMB No. 0704-0188		
Public reporting burden for this collection of information is estimated to average 1 hour per response, including the time for reviewing instructions, searching existing data sources, gathering and maintaining the data needed, and completing and reviewing this collection of information. Send comments regarding this burden estimate or any other aspect of this collection of information, including suggestions for reducing this burden, to Department of Defense, Washington Headquarters Services, Directorate for Information Operations and Reports (0704-0188), 1215 Jefferson Davis Highway, Suite 1204, Arlington, VA 22202-4302. Respondents should be aware that notwithstanding any other provision of law, no person shall be subject to any penalty for failing to comply with a collection of information if it does not display a currently valid OMB control number. PLEASE DO NOT RETURN YOUR FORM TO THE ABOVE ADDRESS.					
1. REPORT DATE	2. REPORT TYPE Professional paper		3. DATES COVERED		
4. TITLE AND SUBTITLE Web-Based Flight Test Training and Mishap Investigation Support			5a. CONTRACT NUMBER		
			5b. GRANT NUMBER		
			5c. PROGRAM ELEMENT NUMBER		
6. AUTHOR(S) Dean Carico			5d. PROJECT NUMBER		
			5e. TASK NUMBER		
			5f. WORK UNIT NUMBER		
7. PERFORMING ORGANIZATION NAME(S) AND ADDRESS(ES) Naval Air Warfare Center Aircraft Division 22347 Cedar Point Road, Unit #6 Patuxent River, Maryland 20670-1161			8. PERFORMING ORGANIZATION REPORT NUMBER		
9. SPONSORING/MONITORING AGENCY NAME(S) AND ADDRESS(ES)			10. SPONSOR/MONITOR'S ACRONYM(S)		
			11. SPONSOR/MONITOR'S REPORT NUMBER(S)		
12. DISTRIBUTION/AVAILABILITY STATEMENT Approved for public release; distribution is unlimited.					
13. SUPPLEMENTARY NOTES					
14. ABSTRACT Work is ongoing to develop a web-based capability to support flight testing and mishap investigations. Fewer new aircraft are being procured today compared to aircraft procurement a couple decades ago. As the older members of the test force retire or change jobs, more pressure is placed on the more junior engineers to conduct the testing. Flight test training is accomplished at government and commercial test pilot schools, but after graduating the flight test engineers and pilots must primarily work with on-the-job training. One approach to improve flight test training support, currently being developed as part of a small business innovative research program, involves combining advanced technology programs associated with a physics-based analysis model structure and the World Wide Web. This paper discusses the results of the ongoing program to enhance and integrate an advanced simulation model structure with a collaborative network and with advanced microprocessors.					
15. SUBJECT TERMS Flight test training					
16. SECURITY CLASSIFICATION OF:			17. LIMITATION OF ABSTRACT	18. NUMBER OF PAGES	19a. NAME OF RESPONSIBLE PERSON
a. REPORT	b. ABSTRACT	c. THIS PAGE			Dean Carico
Unclassified	Unclassified	Unclassified	SAR	10	19b. TELEPHONE NUMBER (include area code) (301) 342-1382

Standard Form 298 (Rev. 8-98)
Prescribed by ANSI Std. Z39-18

QUALITY INSPECTED

20010109 032

Web-Based Flight Test Training & Mishap Investigation Support

Dean Carico, Code AIR 4.11.3.2
Test & Evaluation Engineering
Naval Air Warfare Center Aircraft Division
Patuxent River, MD 20670
Caricogd@navair.navy.mil
(301) 342-1382

Dr. Chengjian He, Director of Research
Advanced Rotorcraft Technology
Mountain View, CA 94043
He@flightlab.com
(650) 968-1464

Peter Blemel, Program Manager
Management Sciences, Inc.
Albuquerque, NM 87110
Peter@mgtsciences.com
(505) 255-8611

Abstract—Work is ongoing to develop a web-based capability to support flight testing and mishap investigations. Fewer new aircraft are being procured today compared to aircraft procurement a couple decades ago. As the older members of the test force retire or change jobs, more pressure is placed on the more junior engineers to conduct the testing. Flight test training is accomplished at government and commercial test pilot schools, but after graduating the flight test engineers and pilots must primarily work with on-the-job training. One approach to improve flight test training support, currently being developed as part of a small business innovative research program, involves combining advanced technology programs associated with a physics-based analysis model structure and the World Wide Web. This paper discusses the results of the ongoing program to enhance and integrate an advanced simulation model structure with a collaborative network and with advanced microprocessors.

Background

Flight Testing—Although the concept of aircraft originated several centuries ago, it was not until 1903 that the Wright brothers were able to push existing technology and demonstrate powered aircraft flight. Early flight testing was performed by entrepreneurs who were jacks-of-all trades who may have designed the aircraft, built it, and conducted the flight testing. It was not until 1943 that the Navy consolidated five East Coast activities to form the Naval Air Test Center at Patuxent River, MD. A three month Flight Test Pilot's training program was initiated in 1945. The Test Pilot Training Division was established in 1948 with six month classes. The Test Pilot Training Division became the US Navy Test Pilot School in 1958, and a formal rotary wing curriculum was established in 1961. The USNTPS curriculum was restructured to an 11 month program in 1973. The Air Force Test Pilot School started at Wright Field, Ohio, in 1944 as the US Army Air Force Wright Patterson School, and it was moved to Edwards Air Force Base in 1951. Both Navy and Air Force test pilot schools

continue to provide comprehensive flight test training for pilots and for new engineers. Short courses on various aspects of flight testing are available through several universities and commercial activities. It is difficult to provide training to experienced engineers that are needed for a specific upcoming flight test program. The personnel computer, introduced in the 1980's, and the world wide web, introduced in the 1990's, when integrated and enhanced have the potential to revolutionize flight test training required for individual test team members.

Mishap Investigations—Soon after aircraft started flying, problems occurred, and mishaps happened. Due to the nature of flying (speed, altitude, noise, etc), the regulatory process was initiated. The origin of mishap investigation, summarized by Clarke [1], dates back to the Air Commerce Act of 1926 that provided the responsibility to "investigate, record and make public the causes of accidents in civil air navigation." Follow-on changes were due primarily to crashes involving famous people (Knut Rockne -1931, Will Rogers & Wiley Post - 1935) or spectacular crashes like the Hindenburg in 1937. These mishaps led to the formation of a five member accident investigation board. The Civil Aeronautics Act was passed in 1938 that established a Civil Aeronautics Authority with an Air Safety Board to investigate aircraft accidents. The Civil Aeronautics Administration was established in 1940, with a Civil Aeronautics Board of five members responsible for aircraft mishap investigations. Airline crashes during the 1956 to 1958 period helped to spur on the establishment of the Federal Aviation Agency in 1958 which was responsible for aviation matters. As a result of different approaches to accident investigation by the FAA and Bureau of Safety, the Department of Transportation was established in 1966. The DOT included the FAA, and the Bureau of Safety became the National Transportation Safety Board (NTSB). Following two DC-10 mishaps in the early 1970's, Congress made the NTSB an independent agency, as we know it today. It is important for the test team to understand enough about the test aircraft and test conditions to prevent mishaps before they occur. On the other hand, flight test is a high

risk type of work and mishaps will occur. If a mishap occurs, it is important to understand why it occurred so that it can be prevented from occurring again.

WWW—The World Wide Web may be thought of as a relatively recent step to a rapidly growing computer industry that has dramatically improved communication between flight test team members. The Atlantic cable was laid in the late 1860's to provide a means for improving communication between the US and Europe, and the cable lasted almost 100 years. Following the Soviet Union's successful launch of Sputnik in 1957, the Advanced Research Projects Agency (ARPA) was established. In 1962, ARPA conducted research into improving computer technology for military applications. This work provided the technology that led to the ARPANET and by the end of 1969, host computers were connected at UCLA, Stanford, UC Santa Barbara, and University of Utah. The ARPANET continued to grow and became the Internet in the early 1980's. The World Wide Web was born in 1991, and by the mid 1990's over 10 million hosts were online. Today, the WWW offers many options to enhance communication, as well as, many options to help support future flight testing and mishap investigations.

Introduction

Collaborative Network (VTeamWare™)—The concept of collaborative network has the potential to help bring web based flight testing to test team members at different locations. Commercial firms use the Internet to focus on issues such as product design, manufacturing, and quality. The Internet is used to connect the corporate teams for discussions on how to achieve goals. The Internet provides a unique opportunity to bring together the system engineers, aircraft designers, test planners, flight test pilots, simulation developers, and other team players and stakeholders. In the past, the distances have made it difficult to share models, algorithms, and test data toward a common goal. The Internet and collaborative network can be used to provide the flight test team with an efficient way to work together on a daily basis. The Internet also provides the infrastructure and communications technology to link the data from microprocessor modules to the analysis team.

Real-Time Telemetry and Microprocessors—Providing real time data from microprocessor units installed on an aircraft would help speed up model validation and flight test data access and processing. Linking TM for real-time data acquisition with a collaborative network using Internet communication protocols will significantly lower the cost of data acquisition. This will make flight tests much more affordable and much more effective. This program involves interfacing advanced microprocessors (Sentient Instrumentation Controllers (SIC)) with the Navy's real time TM using wireless transceivers. Sentient data acquisition

modules linked with NAVAIR's new real time telemetry method overcomes the current problem of getting the sensor data out of the rotating reference frame. Sentients can store volumes of data for wireless infra-red transfer and telemetry to ground stations. In operation the interface to Real TM will connect the low cost Sentients placed aboard the test aircraft to gather data on loads, forces, accelerations and other parameters. The information from the instruments is needed for model validation and verification. The Sentient is not a panacea, as some parameters, like the rotor/fuselage interactional aerodynamics, and even low 3-D airspeed, are very difficult to measure and/or it is not currently possible to measure these parameters accurately.

The low cost Sentient has multiplexed analog to digital (A/D) converters that process analog signals from the sensors into digital data. The digital data can be further processed in the SIC to digital information. The interface will be created so that either raw digital data or processed digital information can be connected directly to an on-board personal computer, or transmitted via data link to ground based systems. Only the sensory capabilities are needed for model validation. The sensor values can be compared with those estimated by the simulator models.

Beta Test Sites

The Beta Sites in this project will be "virtual team sites". The "initial beta" system will be the prototype that was constructed and demonstrated during Phase I of the small business innovative research program. The purpose of the initial beta "Virtual Test Support Lab" is to provide a means to get feedback during development of the interface software developed to support flight testing and mishap investigation. The initial beta site will use and evaluate the functionality and usefulness of the interface and recommend improvements and new features. The Navy test and evaluation (T&E) group will use the initial beta site version of the interface to assess the readiness of the capabilities to be used by sponsor sites. The initial beta interface will connect via the internet to computers at the program contractors (MSI & ART), and the NAVAIR T&E group. The NAVAIR T&E team will represent the customer community and will make judgements and recommendations based on current capabilities. The NAVAIR team will use the initial beta site to provide technical oversight as the flight test support enhancements are developed. Feedback from the participants will be used to direct enhancements of the methodology. When the Navy T&E group deems the initial beta system as being ready for use by others, the contractor team will set up first release (Beta) sites accessed by each of the sponsors. The project sponsors are PMA273 (T45), PMA299 (H60), PMA276 (H1), and PMA251 (ALRE). Each PMA will provide "as available" access to test flights. The contract team will collaborate with each sponsor technical staff team to

establish the individual requirements. The contractor team will establish a beta site at each sponsor's site once the Navy T&E group has approved release of the beta version of the interface.

Air Vehicle Models

Flight testing involves a variety of air vehicle types designed for specific missions. Comprehensive simulation math models used to support flight testing should be able to represent a variety of aircraft types and related aircraft systems. This program work will focus on three aircraft types, including two rotorcraft and one fixed-wing aircraft.

SH-60B - The SH-60B Seahawk helicopter, shown in figure 1, is manufactured by Sikorsky Aircraft Division of United Technologies for the Navy antisubmarine warfare (ASW) mission. It features a four bladed, fully articulated main rotor system and a 20 degree canted tractor trail rotor system. It has General Electric T700-GE-401 engines, tricycle landing gear, and a variable incidence horizontal stabilator.

AH-1W - The AH-1W Super Cobra helicopter, shown in figure 2, is manufactured by Bell Helicopter Textron for the Marine Corps attack mission. It features a two place tandem cockpit, a teetering main rotor system, skid landing gear and has General Electric T700-GE-401 engines.

T-45 - The T-45 is a single engine fixed wing aircraft manufactured by Boeing for the primary jet training mission (figure 3).

A generic simulation model structure is important in demonstrating web-based flight test training on different types of helicopters, plus fixed-wing aircraft.

Model Validation—Model validation will be approached using available flight test and wind tunnel data and any flight test data obtained from the microprocessors. The functional requirements for a web-based flight test support tool to provide flight test support for SH-60B & AH-1W rotorcraft and the T-45 models will be defined. This work will include validating the aircraft throughout the flight envelope for powered and unpowered flight. This work will focus on demonstrating flight test support for the effects of parameter variations for aircraft performance, handling qualities, and loads testing using standard USNTPS test techniques where applicable. The Navy is currently using intelligent systems technology to automatically identify critical points in the flight test envelope for a range of parameter variations on the test vehicle. In this program a representative flight test will be simulated to demonstrate the FLIGHTLAB simulation model ability to predict critical points in a collaborative environment for a Navy designated aircraft and parameter set. The simulation model generic structure will permit different type aircraft (i.e. rotorcraft and fixed wing) to be readily analyzed. Flight test support features developed for one type aircraft may be transferred

to another. The generic structure will also permit specialized applications to be analyzed in as much detail as required.

Specialized Rotorcraft Flight Test Scenarios

The interaction of aerodynamic interference between various parts of a rotorcraft has major effects on the stability, performance and loads of the rotorcraft. The interaction of pilot, rotorcraft, and environment in certain near-the-ground situations, can lead to the loss of situational awareness. These effects include:

- loss of tail rotor effectiveness or unanticipated right yaw
- vortex ring state
- downwind turn

Under certain low speed conditions a single rotor helicopter may lose tail rotor effectiveness or encounter an unanticipated right yaw (URY) condition. If the pilot does not quickly recognize the condition and apply corrective control (full left pedal) the right yaw may become high enough to produce spins and cause the aircraft to crash. Several mishaps involving URY have been documented [2] [3]. Figure 4 shows a free main rotor wake and ground vortex model used in loss of tail rotor effectiveness analysis. Both main rotor wake and ground vortex will be modeled and tested in a simulated flight test environment.

Powered vertical or near vertical flight may be classified in three flight regimes: (1) the normal working state (hover or climb), (2) the windmill brake state (rapid descent), and (3) the vortex ring state. In both the normal working state and windmill brake state, a definite air flow slipstream through the rotor exists. In the vortex ring state, the combination of the flow up through the rotor, and the downward rotor induced velocity means that a definite slipstream through the rotor does not exist. The airflow at the rotor is characterized by turbulent flow with rapidly changing local velocities which increases the pilot workload. If the pilot pulls more power (collective control), the rate of descent increases. The key is to gain forward airspeed to get out of the vortex ring condition. Several helicopter mishaps have been attributed to the pilot inadvertently getting into the vortex ring state [4][5]. A sample vortex ring boundary for the SH-60 helicopter is shown in figure 5 [5]. Figure 6 shows a unified finite state dynamic wake model application across normal and vortex ring state conditions [5]. It is important to develop models for training that not only predict the vortex ring boundary, but also predict rotor blade force and moment characteristics at any blade span or azimuth.

The flight conditions encountered in a downwind turn can also create a dangerous aerodynamic environment. Turning

downwind may cause the pilot to go from a "needle-ball-air-speed" scan to a visual ground reference. When the wind is high and the helicopter is close to the ground, a lack of situational awareness on the part of the pilot may result in a URY condition or a vortex ring state condition. Several mishaps involving downwind turn conditions, loss of tail effectiveness, and vortex ring state have been reported [2]&[3]. In this program the aerodynamic phenomena that contribute to these specialized scenarios will be modeled. The modeling will include main and tail rotor wake models, interference models, plus ground vortex wake models. Figure 7 shows a plot of wind speed ratio versus true airspeed, where wind speed ratio is wind speed divided by true airspeed. From figure 7, wind speed ratios of approximately .4 represent a proposed instructor limit. Web based flight test training and mishap investigation support will have to consider the pilot visual workload in the low speed ground reference frame.

Shipboard Applications

The SH-60B, AH-1W, and T45 models will be utilized in simulated shipboard landing tests. The ability to systematically vary the many parameters associated with helicopter/ship or Dynamic Interface testing analytically in a simulated environment will be required to support DI testing. Predicted results will be compared with data recorded from Sentients microprocessors and other sources to validate the models. It is important for test team members to be able to analytically vary key flight test parameters like:

- Ship Airwake Model (wind over the deck speed and direction, plus turbulence amplitude & frequency)
- Aircraft Model (gross weight, center of gravity, etc.)
- Ship Motion (amplitude & frequency)
- Visual Scene (visibility & flight deck lighting & marking)
- Approach Profile (up the stern or oblique)
- Instrumentation (microprocessor applications)

Mishap Investigations

The analytical model will be used to simulate mishaps by using signal processing techniques such as inverse simulation or a Kaman Filter/Smoothing to determine the input time histories to the flight vehicle required to produce the recorded trajectory. This is a combination of the control inputs and increments to the predicted ship airwake and interference effects. Once some combination of these modeling errors has been identified that will reproduce the recorded results, the model will be modified as required to improve correlation with the aerodynamic effects predicted by inverse simulation. The collaborative network interface can bring together distanced specialists participating in the investigation. The ability to accurately reproduce a mishap

in a simulated scenario will greatly facilitate analysis of the mishap.

Joint Service Applications

The cost of future aircraft dictates that new air vehicle acquisition be multi-service and/or multi-national programs. Currently Army pilots and engineers are trained at the US Naval Test Pilot School. The WWW provides an option to help integrate multi-service test requirements. Both the Army Technical Test Center and the Naval Air Warfare Center test H-60 rotorcraft. This program will include a demonstration of an analytical H-60 air vehicle test that includes both Army and Navy personnel. Using the collaborative network and the same math model, specific test programs can be conducted without either team leaving their test activity.

The Joint Test and Evaluation (JT&E) program solicits nominations for potential topics that bring the Services together to accomplish specific objectives, including:

- Evaluate and validate testing methodologies having multi-Service applications, etc.

The proposed Joint Enhanced Rotorcraft Test and Operational Capability (JERTOC) concept [6] involves enhancing and integrating advanced technology programs in aircraft and engine simulation modeling, design, test planning, and test reporting to better support acquisition, testing and training. An initial goal of this program concept is to develop the capability to do analytically in one month what might currently take more than two years of actual air vehicle flight testing. A final goal includes using the capability of a high performance computing (HPC) center to analytically run a helicopter air vehicle test program in one 24 hr period. The complexity of helicopter rotor models and related loads and inflow modules, fuselage models, and engine models, plus associated ship airwake models, require improved software and high performance computing hardware. The JERTOC program concept will form a unified environment to enhance rotorcraft testing in land and shipboard environments. This unified environment could be used to support current and next generation aircraft/systems design and testing. The JERTOC program initial focus is on testing, validating and applying the technology developed to the multi-service H-60 helicopter. The generic nature of the technology developed makes it readily adaptable to other rotorcraft, unmanned aerial vehicles, or fixed wing aircraft as required. The program concept includes starting with a physics-based analysis/simulation structure and adding/integrating, testing and validating enhancement modules in the areas listed below and illustrated in figure 8.

- Air vehicle design
- Load predicting ability
- Engine design/test

- Flight test interface
- Multi-media flight test plan and report automation
- VV&A with built-in validation
- 3-D component modeling options

The JERTOC concept focuses on acquisition, testing, and training. The program would address evaluating and validating methodologies to reduce the cost and time required for aircraft acquisition and testing, and reduce the cost associated with conventional flight trainers. The ongoing research work to develop web-based flight test support and mishap investigation support will help provide one item in the technical database needed to support the JERTOC concept.

Summary

This program involves developing and demonstrating web-based flight test training and mishap investigation support to help reduce the cost associated with conventional testing and related analysis. It includes integrating and enhancing collaborative network technology, air vehicle simulation technology, and microprocessor technology. The resulting technology will be applied to the SH-60B and AH-1W rotorcraft and to the T-45 fixed wing trainer. The web-based training will focus on the standard US Navy Test Pilot School test procedures. Specialized flight testing training support will also include the mishap prone vortex ring state, loss of tail rotor effectiveness state, and downwind turn condition. Shipboard landings are important for Navy/Marine Corps aircraft applications. Shipboard operations will be modeled analytically to support training in this environment. The advanced simulation and collaborative network capability will be used to support future mishap investigations. The technology developed in this program will be used to support a joint Army/Navy rotorcraft analytical test program.

References

- [1] Clarke, George, Class Notes: Aircraft Accident Investigation, 1990.
- [2] Kolwey, Herman, "Conquering the Downwind Turn – SFTE Paper Follow-Up," paper to be published.
- [3] McCool, Kelly and Haas, David, "Analytical Investigation of Flight Conditions Leading to Unanticipated Right Yaw," AHS Aerodynamics Specialist Conference, San Francisco, CA., Jan 1994.
- [4] Xin, Hong and Gao, Zheng, "A Prediction of the Vortex Ring State Boundary Based on Model Tests," Transactions of Nanjing University of Aeronautics & Astronautics, Vol. 11 No. 2 of Dec 1994.
- [5] He, Chengjian, et.al., "Rotorcraft Model Enhancements to Support Land and Sea-Based Testing and Operational Analysis," NAVAIR small business contract No. N00421-98-C-1121, Final Report, Dec. 1999.

- [6] Carico, Dean and Blemel, Ken, "Joint Enhanced Rotorcraft Test and Operational Capability (JERTOC) for the 21st Century," 2000 IEEE Aerospace Conference, Big Sky, MO., Mar. 2000.



Dean Carico is an aerospace engineer in the rotorcraft shipboard suitability group in test and evaluation engineering at the Naval Air Warfare Center at Patuxent River, MD. Dean initiated a high performance computing program on flight test automation, a rotorcraft simulation to support flight testing program, and over fifteen small business innovative research programs that focus on enhancing rotorcraft flight testing. Dean developed the JT&E JERTOC concept in 1997. Dean has masters degrees in Aerospace Engineering from Princeton and in Engineering Science from the Navy Postgraduate School, and is an engineering graduate from the USNTPS. He received the Meritorious Civilian Service Award for testing in a combat zone in 1973, and the Richard L. Wernecke Award for technical excellence in rotorcraft test and evaluation in 1997.



Dr. ChengJian He is the Director of Research and Development at the Advanced Rotorcraft Technology, Inc. (ART) in Mountain View, CA. He is a co-developer of the Peters/He finite state dynamic wake theory. His expertise is in the field of unsteady aerodynamics, aeroelasticity, flight simulation and development of comprehensive engineering analysis and simulation software system. He received his doctorate from GA Tech and initially worked as a Research Engineer at GA Tech. Dr. He worked at Lockheed as a senior engineer before coming to ART in 1993. Dr. He is in charge of the research and development activities at ART, and has published more than 20 technical papers.

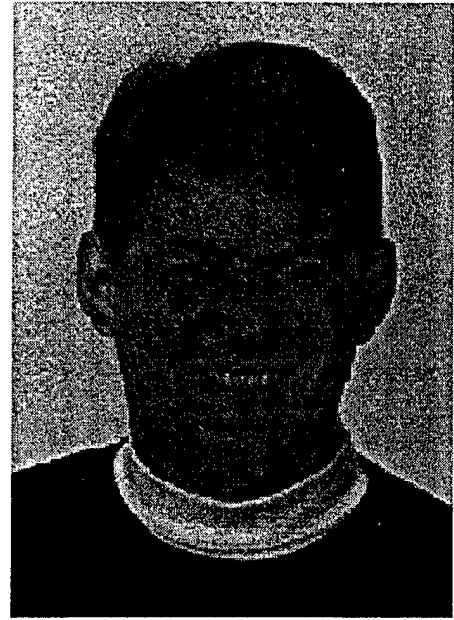

Mr. Peter Blemel is a Program Manager at Management Sciences, Inc. (MSI) at Albuquerque, NM. Mr. Blemel is responsible for managing all computer software development at MSI. Mr. Blemel was responsible for the DARPA/RASSP software development under contract from Lockheed Martin Advanced Technology Laboratory. Mr. Blemel also was responsible for developing the MSI software used with the MOM program for fault tolerant networked computer task management. He has a degree in Mathematics and Computer Sciences from the University of NM. And has worked at MSI from 1991 to the present.

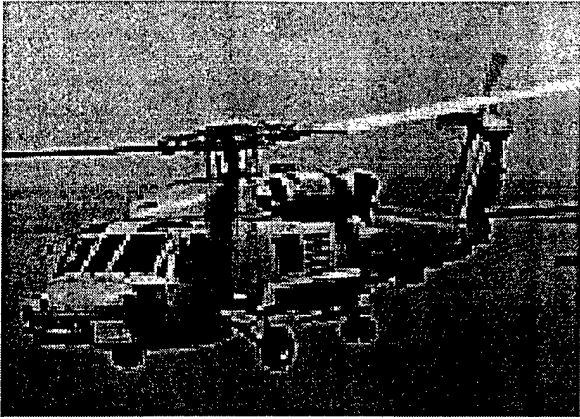

Figure 1 SH-60B Helicopter

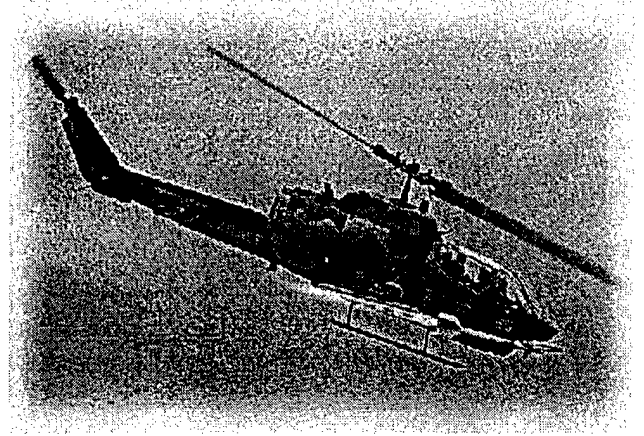

Figure 2 AH-1W Helicopter

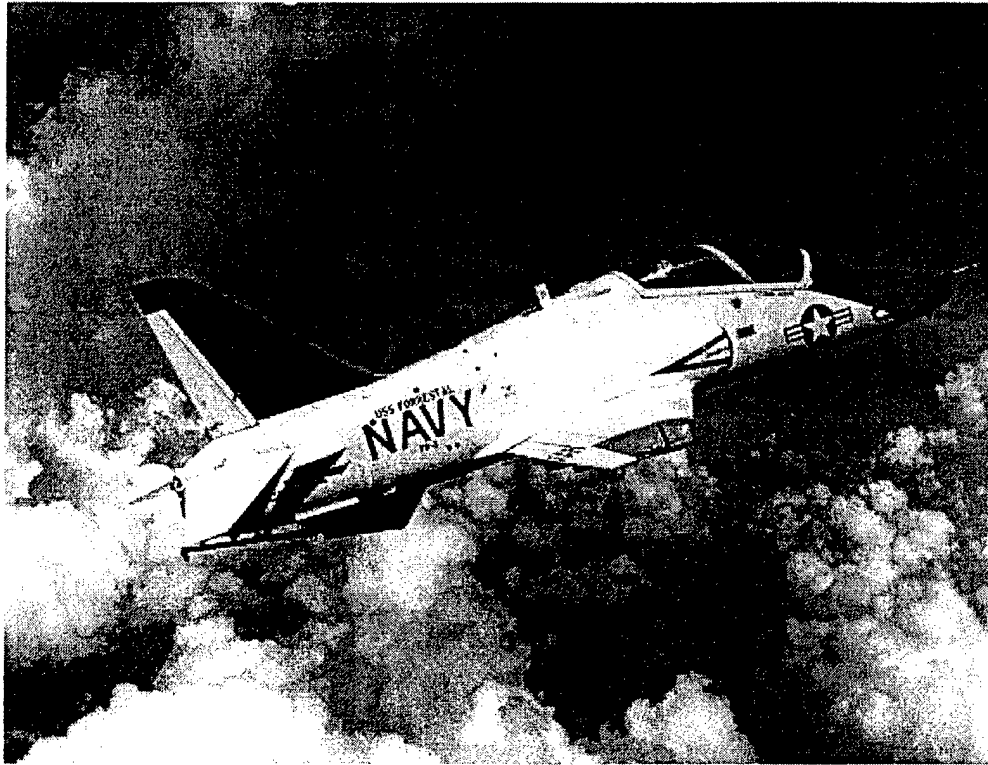

Figure 3 T45 Aircraft

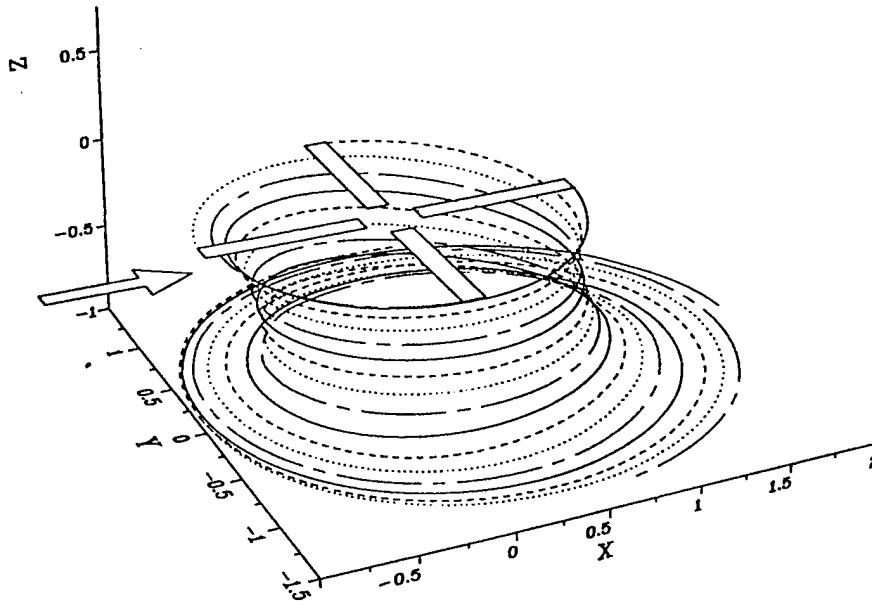

Figure 4 Free Wake (Main Rotor) and Ground Vortex Model

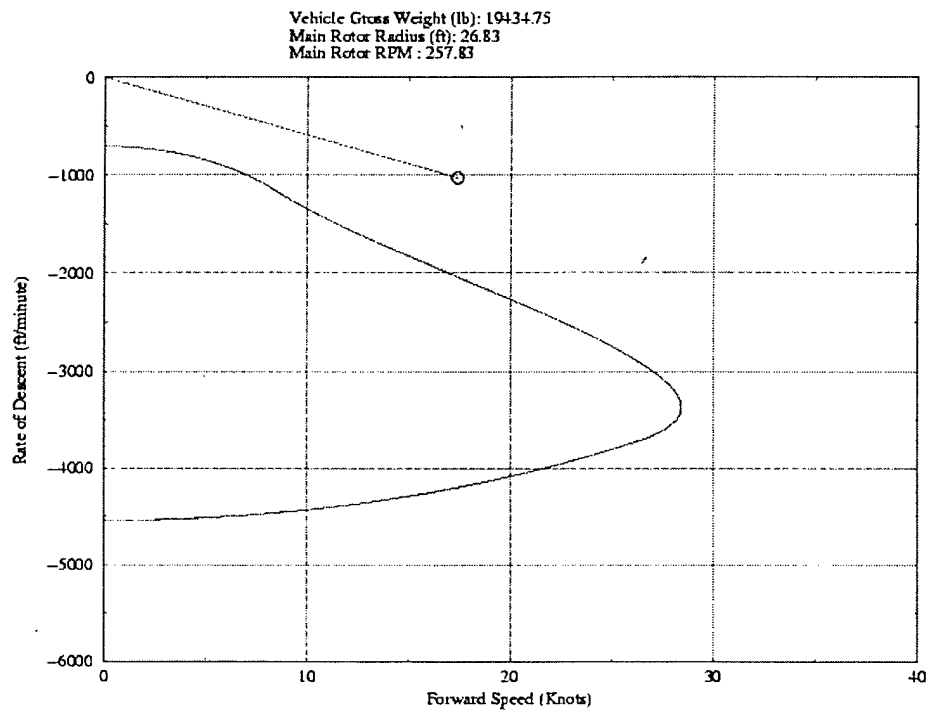

Figure 5 Predicted Vortex Ring State Boundary Plot Showing Flight Condition

Inflow Variation in Vertical Descent

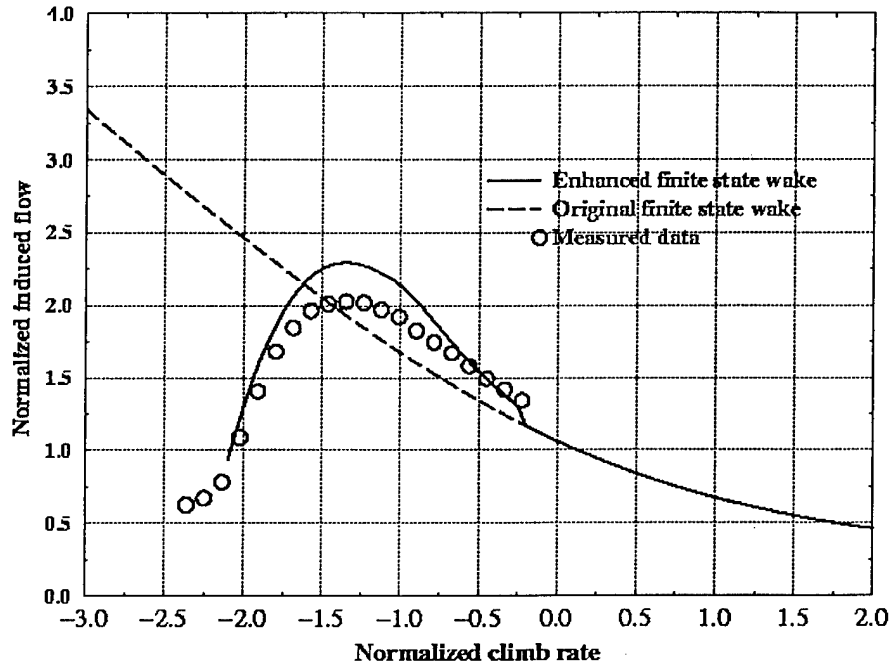

Figure 6 Inflow Variation in Vertical Descent

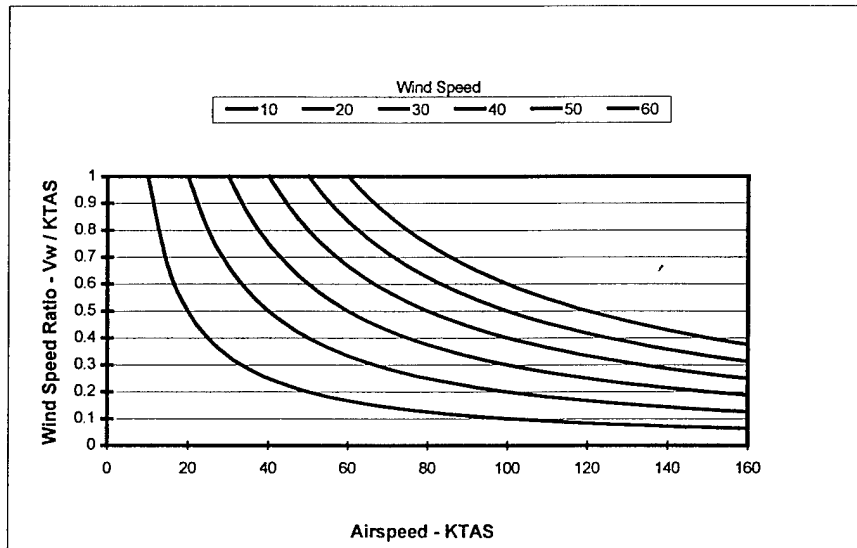

Figure 7 Wind Speed Ratio Diagram

Figure 8

JERTO Summary

