

# LOAN DOCUMENT

PHOTOGRAPH THIS SHEET

DTIC ACCESSION NUMBER

LEVEL

INVENTORY

*BIOVENTINO PILOT TEST WORK...*

DOCUMENT IDENTIFICATION

*DEC 92*

**DISTRIBUTION STATEMENT A**  
Approved for Public Release  
Distribution Unlimited

DISTRIBUTION STATEMENT

ACCESSION FOR	
NTIS	GRAM
DTIC	TRAC
UNANNOUNCED	
JUSTIFICATION	
BY	
DISTRIBUTION/	
AVAILABILITY CODES	
DISTRIBUTION	AVAILABILITY AND/OR SPECIAL
<i>A-1</i>	

DISTRIBUTION STAMP

DATE ACCESSIONED

DATE RETURNED

REGISTERED OR CERTIFIED NUMBER

20001215 087

DATE RECEIVED IN DTIC

REGISTERED OR CERTIFIED NUMBER

PHOTOGRAPH THIS SHEET AND RETURN TO DTIC-FDAC

H  
A  
N  
D  
L  
E  
  
W  
I  
T  
H  
  
C  
A  
R  
E

# **PART I**

**Bioventing Pilot Test Work Plan for  
POL Storage Area C  
Tinker AFB, Oklahoma**

# **PART II**

**Draft Interim Pilot Test Results Report for  
POL Storage Area C  
Tinker AFB, Oklahoma**

**Prepared For**

**Air Force Center for Environmental Excellence  
Brooks AFB, Texas**

**and**

**Oklahoma City Air Force Logistics Center  
Environmental Management  
TinkerAFB, Oklahoma**

**ES**  
**Engineering-Science, Inc.**

**December 1992**

1700 BROADWAY, SUITE 900  
DENVER, COLORADO 80290

**ES ENGINEERING-SCIENCE**

*AQM01-03-0538*

### DEFENSE TECHNICAL INFORMATION CENTER REQUEST FOR SCIENTIFIC AND TECHNICAL REPORTS

Title AFCEE Collection

**1. Report Availability** (Please check one box)

- This report is available. Complete sections 2a - 2f.
- This report is not available. Complete section 3.

**2a. Number of Copies Forwarded**

Each

**2b. Forwarding Date**

July/2000

**2c. Distribution Statement** (Please check ONE box)

*DoD Directive 5230.24, "Distribution Statements on Technical Documents," 18 Mar 87, contains seven distribution statements, as described briefly below. Technical documents MUST be assigned a distribution statement.*

- DISTRIBUTION STATEMENT A:** Approved for public release. Distribution is unlimited.
- DISTRIBUTION STATEMENT B:** Distribution authorized to U.S. Government Agencies only.
- DISTRIBUTION STATEMENT C:** Distribution authorized to U.S. Government Agencies and their contractors.
- DISTRIBUTION STATEMENT D:** Distribution authorized to U.S. Department of Defense (DoD) and U.S. DoD contractors only.
- DISTRIBUTION STATEMENT E:** Distribution authorized to U.S. Department of Defense (DoD) components only.
- DISTRIBUTION STATEMENT F:** Further dissemination only as directed by the controlling DoD office indicated below or by higher authority.
- DISTRIBUTION STATEMENT X:** Distribution authorized to U.S. Government agencies and private individuals or enterprises eligible to obtain export-controlled technical data in accordance with DoD Directive 5230.25, Withholding of Unclassified Technical Data from Public Disclosure, 6 Nov 84.

**2d. Reason For the Above Distribution Statement** (in accordance with DoD Directive 5230.24)

**2e. Controlling Office**

HQ AFCEE

**2f. Date of Distribution Statement Determination**

15 Nov 2000

**3. This report is NOT forwarded for the following reasons.** (Please check appropriate box)

- It was previously forwarded to DTIC on \_\_\_\_\_ (date) and the AD number is \_\_\_\_\_
- It will be published at a later date. Enter approximate date if known. \_\_\_\_\_
- In accordance with the provisions of DoD Directive 3200.12, the requested document is not supplied because: \_\_\_\_\_

Print or Type Name

Laura Peña

Telephone

210-536-1431

Signature

Laura Peña

AQ Number

M01-03-0538

**PART I**  
**BIOVENTING PILOT TEST WORK PLAN**  
**FOR**  
**POL STORAGE AREA C**  
**TINKER AFB, OKLAHOMA**

**December 1992**

**Prepared for:**

**Air Force Center for Environmental Excellence**  
**Brooks AFB, Texas**

**and**

**Oklahoma City Air Force Logistics Center**  
**Environmental Management**  
**Tinker AFB, Oklahoma**

**by:**

**Engineering-Science, Inc.**  
**1700 Broadway, Suite 900**  
**Denver, Colorado**

## CONTENTS

### PART I - BIOVENTING PILOT TEST WORK PLAN FOR POL STORAGE AREA C TINKER AFB, OKLAHOMA

	<u>Page</u>
1.0 Introduction.....	I-1
2.0 Site Description .....	I-1
2.1 Petroleum, Oils, and Lubricants Storage Area C .....	I-1
2.1.1 Site Location and History .....	I-1
2.1.2 Site Geology .....	I-4
2.1.3 Site Contaminants .....	I-4
3.0 Site Specific Activities .....	I-4
3.1 Site Layout .....	I-5
3.2 Vent Well .....	I-5
3.3 Monitoring Points .....	I-5
3.4 Handling of Drill Cuttings .....	I-9
3.5 Soil and Soil Gas Sampling .....	I-9
3.5.1 Soil Samples .....	I-9
3.5.2 Soil Gas Samples .....	I-9
3.6 Blower System .....	I-10
3.7 <i>In Situ</i> Respiration Test .....	I-10
3.8 Air Permeability Test .....	I-10
3.9 Installation of 1-Year Pilot Test Bioventing System.....	I-10
4.0 Exceptions to Protocol Procedures .....	I-12
5.0 Base Support Requirements	
5.1 Test Preparation.....	I-12
6.0 Project Schedule .....	I-13
7.0 Points of Contact .....	I-13
8.0 References.....	I-14

## FIGURES

<u>No.</u>	<u>Title</u>	<u>Page</u>
2.1	POL Storage Area C Location with Respect to Base .....	I-3
2.2	Site Layout.....	I-4
3.1	Proposed Vent Well/Vapor Monitoring Point Locations .....	I-6
3.2	Proposed Air Injection Vent Well Construction.....	I-7

CONTENTS (Continued)

		<u>Page</u>
FIGURES		
<u>No.</u>	<u>Title</u>	<u>Page</u>
3.3	Proposed Monitoring Point Construction Detail.....	I-9
3.4	Proposed Blower System Instrumentation Diagram for Air Injection.....	I-11

## PART I

# BIOVENTING TEST WORK PLAN FOR POL STORAGE AREA C TINKER AFB, OKLAHOMA

### 1.0 INTRODUCTION

This work plan presents the scope of an *in situ* bioventing pilot test for treatment of fuel-contaminated soils at Petroleum, Oils, and Lubricants (POL) Storage Area C at Tinker Air Force Base (AFB), Oklahoma. The pilot test has three primary objectives: 1) to assess the potential for supplying oxygen throughout the contaminated soil interval, 2) to determine the rate at which indigenous microorganisms will degrade fuel when stimulated by oxygen-rich soil gas, and 3) to evaluate the potential for sustaining these rates of biodegradation until fuel contamination is remediated to concentrations below regulatory standards.

The pilot test will be conducted in two phases. A vent well (VW) and monitoring points (MPs) will be installed during site investigation activities. The initial stage will also include an *in situ* respiration test and an air permeability test. This initial testing is expected to take approximately 2 weeks. During the second phase, a bioventing system will be installed and monitored over a 1-year period.

If bioventing proves to be feasible at this site, pilot test data could be used to design a full-scale remediation system and to estimate the time required for site cleanup. An added benefit of the pilot testing at POL Storage Area C is that a significant amount of the fuel contamination should be biodegraded during the 1-year pilot test, as the testing will take place within the most contaminated soils at the site.

Additional background information on the development and recent success of the bioventing technology is found in the *Test Plan and Technical Protocol For A Field Treatability Test For Bioventing* (Hinchee et al., 1992). This protocol document will also serve as the primary reference for pilot test well designs and detailed procedures which will be used during the test.

## **2.0 SITE DESCRIPTION**

### **2.1 Petroleum, Oils, and Lubricants Storage Area C**

#### **2.1.1 Site Location and History**

POL Storage Area C, also referred to as the 3700 Fuel Yard, is located midway along the eastern boundary of the base, between Warehouse Road and Douglas Boulevard (Figure 2.1). The area of concern within this former jet fuel bulk storage area is located approximately 60 to 200 feet east of Building 3703. Figure 2.2 shows the location of existing monitoring wells within and adjacent to the area of identified petroleum contamination. The location of POL Storage Area C with respect to the base is shown in Figure 2.1.

Six underground storage tanks (USTs), each with a capacity of 25,000 gallons, were previously located in POL Storage Area C (Figure 2.2). After serving in excess of 30 years as a fuel storage depot, the tanks were removed in 1991 along with approximately 1,500 cubic feet of fuel-contaminated backfill material. The excavated area has since been backfilled with clean sand, and the surface has been restored. Surface transportation and storage facilities have replaced the previous underground system. JP-4 jet fuel is now delivered by tanker truck to the site, where it is off-loaded into two aboveground storage tanks located at the southern boundary of the fuel yard (not shown on map).

The USTs, formerly located upgradient of the presently identified contamination, had contained JP-4 jet fuel exclusively in recent years. Petroleum hydrocarbon contamination presumed to have leaked from these tanks or their pipelines is the target for bioventing treatment at this site (Water & Soil Consultants, Inc. (WSCSI), 1992).

#### **2.1.2 Site Geology**

At the POL Storage Area C site, the top of the Garber Sandstone Formation occurs at shallow depths, typically less than 4 feet. The sandstones are red-brown, fine to very fine grained, silty in part, and for the most part poorly cemented and friable. These sandstones are overlain by clayey, fine-grained sands. A perched aquifer holds local ground water, which is encountered at a depth of approximately 17 feet below ground surface (bgs) and generally flows eastward. Ground water flow direction may be influenced locally by surface water and utility corridors.

#### **2.1.3 Site Contaminants**

The primary contaminants at this site are petroleum hydrocarbons, which have been detected in the soils and ground water at depths ranging from 5 to 35 feet bgs. Total recoverable petroleum hydrocarbon (TRPH) concentrations of 1,070 milligrams per kilogram (mg/kg) have been detected in the soils at a depth of 5 to 6 feet. Concentrations of the volatile organic compound benzene were detected at 120  $\mu\text{g}/\text{kg}$  in the soils from the boring for well MW-5 (WSCSI, 1992).

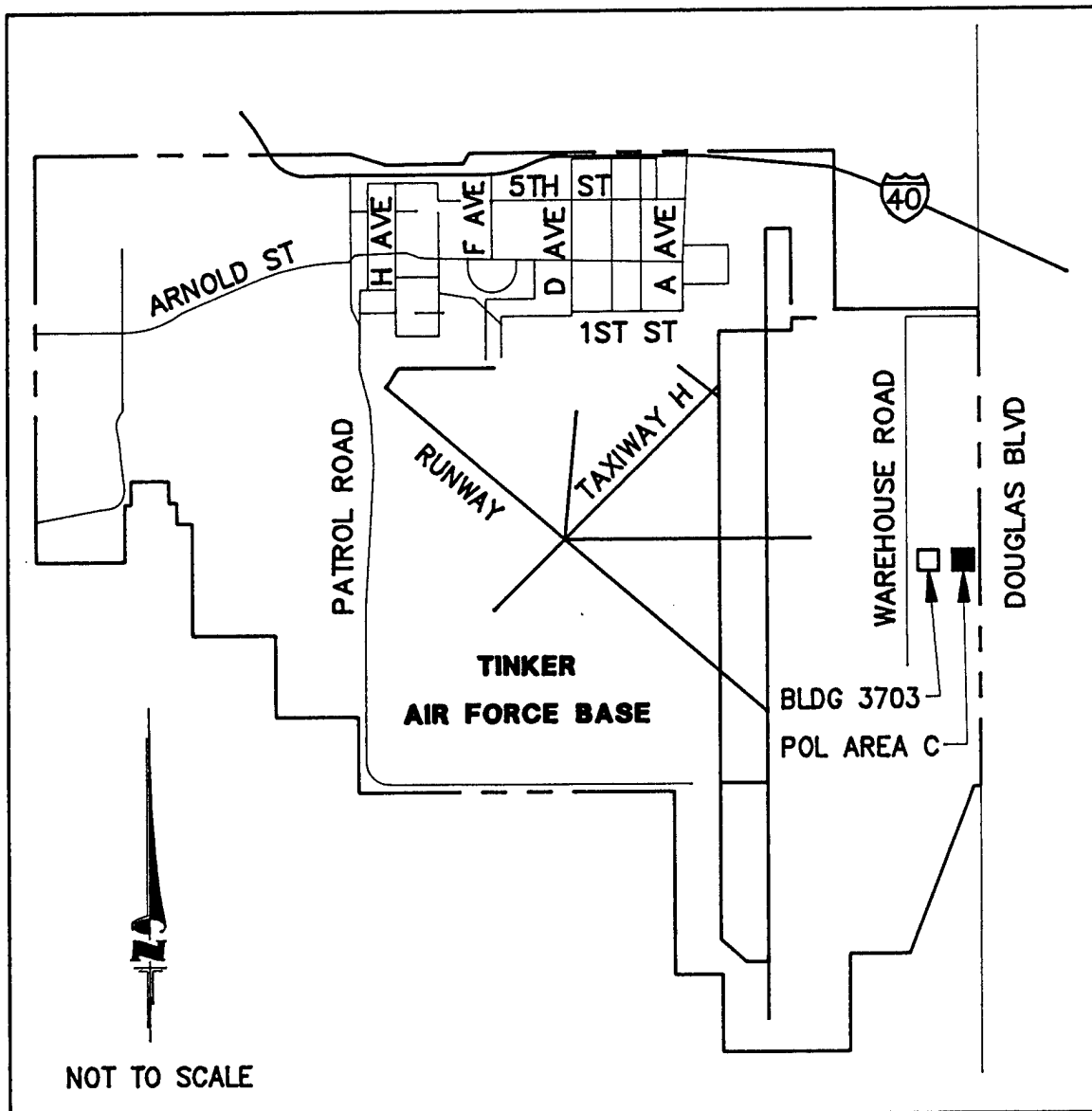
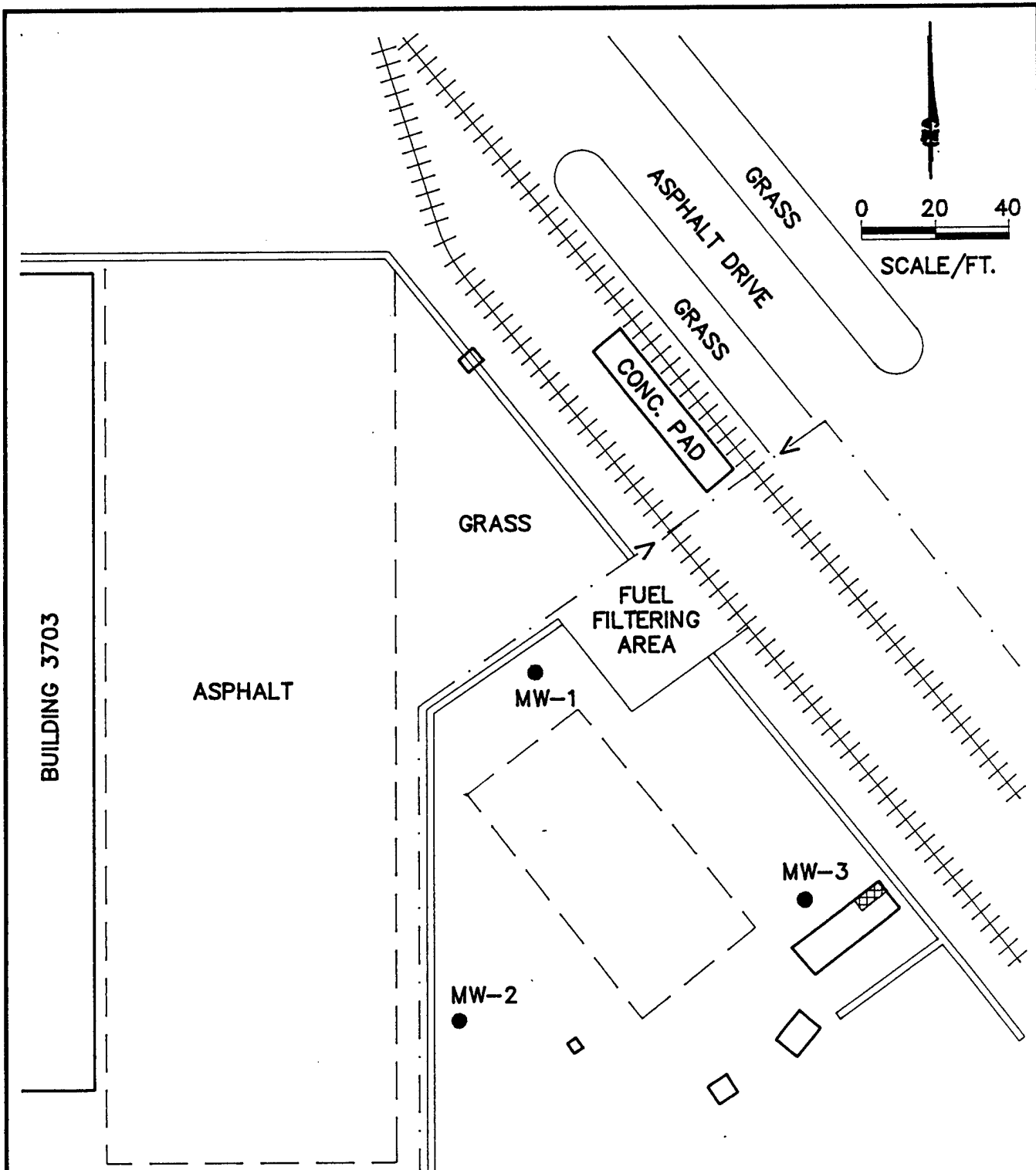

FIGURE 2.1  
 POL STORAGE AREA C  
 LOCATION WITH RESPECT  
 TO BASE

TINKER AFB, OKLAHOMA

ENGINEERING-SCIENCE, INC.  
 Denver, Colorado





- LEGEND:**
- MW-2 ● EXISTING MONITORING WELL
  - ══ PIPELINE
  - ||||| RAILROAD TRACKS
  - ↔ FENCE GATE
  - · - CHAIN LINK FENCE
  - [ · ] FORMER LOCATION OF USTs
  - ▣ POWER PANEL

**FIGURE 2.2**  
**SITE LAYOUT**  
**POL STORAGE AREA C**

TINKER AFB, OKLAHOMA

ENGINEERING-SCIENCE, INC.  
 Denver, Colorado



26816-06, 12/24/92 at 07:15

### 3.0 SITE SPECIFIC ACTIVITIES

The purpose of this section is to describe the work that will be performed by Engineering-Science, Inc. (ES) at POL Storage Area C. Activities that will be performed include siting and construction of a central air injection well, or VW and three vapor MPs; an *in situ* respiration test; an air permeability test; and the installation of a long-term bioventing pilot test system. Soil and soil gas sampling procedures and the blower configuration that will be used to inject air (oxygen) into contaminated soils through the VW are also discussed in this section. No dewatering will take place during the pilot test. Pilot test activities will be confined to unsaturated soils remediation. Existing monitoring wells will not be used as primary air injection wells. However, monitoring wells which have a portion of their screened interval above the water table may be used as vapor MPs or to measure the composition of background soil gas.

#### 3.1 Site Layout

A general description of criteria for siting a central VW and vapor MPs are included in the protocol document (Hinchee et al., 1992). Figure 3.1 illustrates the proposed locations of the central VW and MPs at this site. The final locations of these wells may vary slightly from the proposed locations if significant fuel contamination is not observed in the boring for the VW. Based on site investigation data, the central VW should be located near monitoring well MW-3. Soils in this area are expected to be oxygen depleted (<2%) due to high hydrocarbon levels, and increased biological activity should be stimulated by oxygen-rich soil gas ventilation during pilot test operations.

Due to the relatively shallow depth of contamination at this site and the experience that ES has had with similar soil types, the potential radius of venting influence around the central air injection well is expected to be 20 to 30 feet. Three vapor MPs (MPA, MPB, and MPC) will be located within a 30-foot radial distance of the central VW. A fourth MP will be located upgradient of the site and will be used to measure background levels of oxygen and carbon dioxide and to determine if natural carbon sources are contributing to oxygen uptake during the *in situ* respiration test.

#### 3.2 Vent Well

The VW will be constructed of 4-inch inside-diameter (ID) schedule 80 PVC, with a 10-foot interval of 0.04-inch slotted screen set at 7 to 17 feet bgs. Flush-threaded PVC casing and screen with no organic solvents or glues will be used. The filter pack will be clean, well-rounded silica sand with a 8-12 grain size, and will be placed in the annular space of the screened interval. A 2-foot layer of bentonite pellets, hydrated in place with potable water, will be placed directly over the filter pack. This layer of pellets will prevent the addition of bentonite slurry from saturating the filter pack. A bentonite/cement grout will then be tremied into the remaining annular space above the bentonite pellets to produce an air-tight seal above the screened interval. A complete seal is critical to prevent injected air from short circuiting to the surface during the bioventing test. Figure 3.2 illustrates the proposed VW construction for this site.

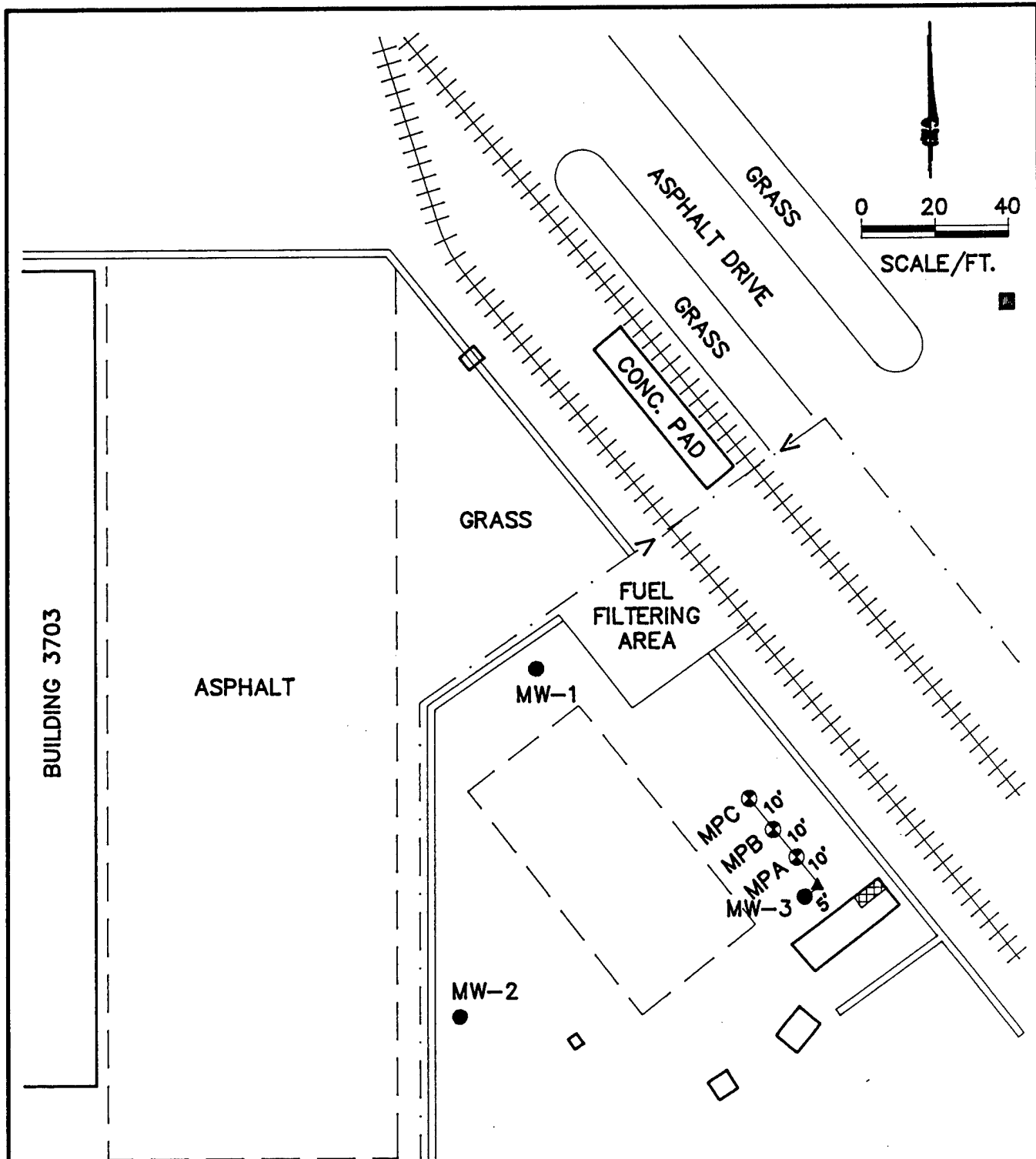

**LEGEND:**

- ▲ PROPOSED VENT WELL (AIR INJECTION)
- ⊙ PROPOSED VAPOR MONITORING POINT
- PROPOSED BACKGROUND WELL
- EXISTING MONITORING WELL
- ⋮ FORMER LOCATION OF USTs
- ▨ POWER PANEL

**FIGURE 3.1**  
**PROPOSED VENT WELL/  
 VAPOR MONITORING POINT  
 LOCATIONS**  
**POL STORAGE AREA C**

TINKER AFB, OKLAHOMA

ENGINEERING-SCIENCE, INC.  
 Denver, Colorado



26816-07, 12/24/92 at 07:35

2" DIAMETER SCH 40  
PVC HEADER SLOPED  
TO WELL

FROM BLOWER

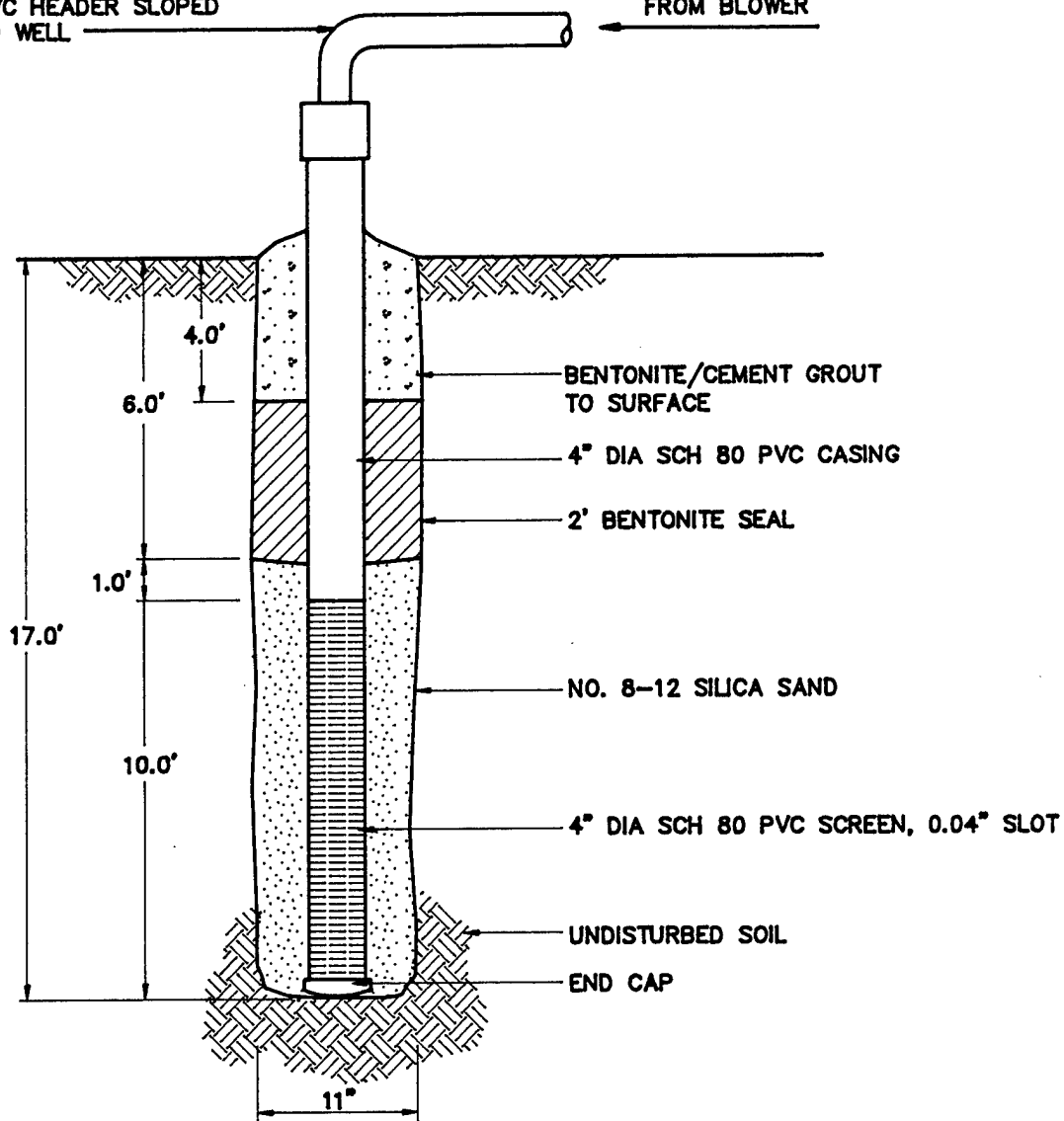

NOT TO SCALE

FIGURE 3.2

PROPOSED AIR INJECTION  
VENT WELL CONSTRUCTION  
POL STORAGE AREA "C"

TINKER AFB, OKLAHOMA

ENGINEERING-SCIENCE, INC.  
Denver, Colorado

ES

### 3.3 Monitoring Points

A typical multi-depth vapor MP installation for this site is shown in Figure 3.3. Soil gas oxygen and carbon dioxide concentrations will be monitored at depth intervals of 5-7 feet, 10-12 feet and 15-17 feet at each location. Multi-depth monitoring will confirm that the entire soil profile is receiving oxygen and be used to measure fuel biodegradation rates at each depth. The spaces between monitoring intervals will be sealed with bentonite to isolate the intervals. As with the central VW, several inches of bentonite pellets will be used to shield the filter pack from rapid infiltration of bentonite slurry additions. Additional details on VW and MP construction are found in Section 4 of the protocol document.

### 3.4 Handling of Drill Cuttings

Cuttings will be collected in U.S. Department of Transportation (DOT) approved containers. The containers will be labeled, and then placed in the Tinker AFB hazardous material storage area. Drill cuttings will become the responsibility of Tinker AFB, or their designated contractor, and will be analyzed and disposed of in accordance with the current procedures for ongoing remedial investigations.

### 3.5 Soil and Soil Gas Sampling

#### 3.5.1 Soil Samples

Three soil samples will be collected from the pilot test area during the installation of the VW and MPs. Sampling procedures will follow those outlined in the protocol document. One sample will be collected from the most contaminated interval of the VW boring, and one sample will be collected from the interval of highest apparent contamination in each of the borings for the two MPs closest to the VW. Soil samples will be analyzed for TRPH, benzene, toluene, ethylbenzene, and xylenes (BTEX), soil moisture, pH, particle sizing, alkalinity, total iron, and nutrients.

Samples for TRPH and BTEX analysis will be collected using a split-spoon sampler containing brass tube liners. Soil samples collected in the brass tubes for TRPH and BTEX analyses will be immediately trimmed, and the ends will be sealed with aluminum foil or Teflon<sup>®</sup> fabric held in place by plastic caps. Soil samples collected for physical parameter analyses will be placed into glass sample jars or other appropriate sample containers specified in the base sample handling plan. Soil samples will be labelled following the nomenclature specified in the protocol document (Section 5), wrapped in plastic, and placed in a cooler for shipment. A chain-of-custody form will be filled out, and the cooler will be shipped to the ES laboratory in Berkeley, California for analysis. This laboratory has been audited by the Air Force and meets all quality assurance/quality control (QA/QC) and certification requirements for the State of California.

#### 3.5.2 Soil Gas Samples

A total hydrocarbon vapor analyzer will be used during drilling to screen split-spoon samples for intervals of high fuel contamination. Initial soil gas samples will be collected in SUMMA<sup>®</sup> canisters in accordance with the *Bioventing Field Sampling*

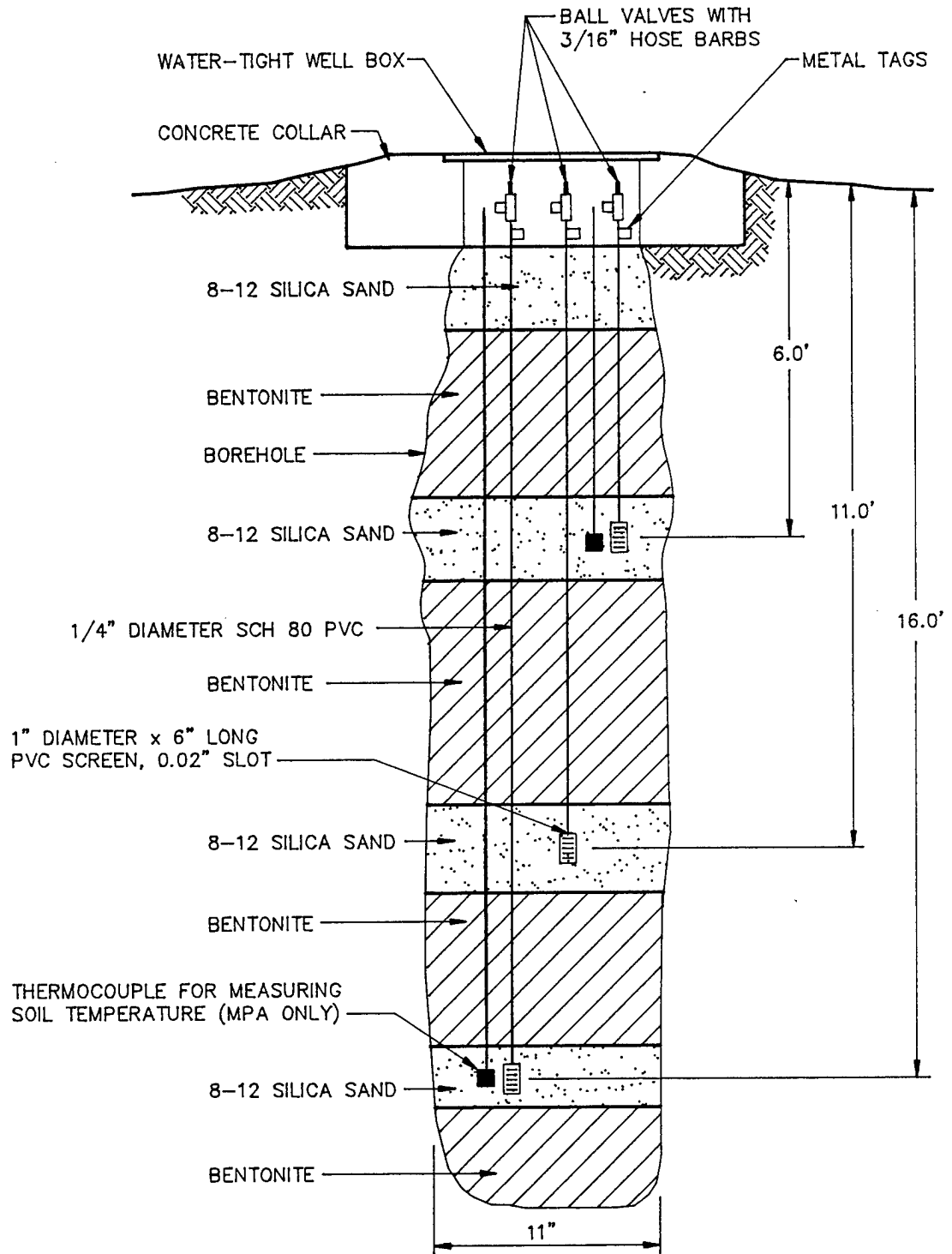

FIGURE 3.3

PROPOSED MONITORING POINT  
CONSTRUCTION DETAIL  
POL STORAGE AREA "C"

TINKER AFB, OKLAHOMA

ENGINEERING-SCIENCE, INC.  
Denver, Colorado

ES

*Plan* (ES, 1992) from the VW and from the MPs closest to and furthest from the VW. Additionally, these soil gas samples will be used to predict potential air emissions, to determine the reduction in BTEX and total volatile hydrocarbons (TVH) during the 1-year test, and to detect any migration of these vapors from the source area.

Soil gas sample canisters will be placed in a small cooler and packed with foam pellets to prevent excessive movement during shipment. Samples will not be sent on ice to prevent condensation of hydrocarbons. A chain-of-custody form will be filled out, and the cooler will be shipped to the Air Toxics, Inc. laboratory in Rancho Cordova, California for analysis.

### **3.6 Blower System**

A 3-horsepower positive-displacement blower capable of injecting air over a wide range of flow rates and pressures will be used to conduct the initial air permeability test and *in situ* respiration test. Figure 3.4 is a schematic of a typical air injection system used for pilot testing. The maximum power requirement anticipated for this pilot test is 230-volt, single-phase, 30-amp service. Additional details on power supply requirements are described in Section 5.0, Base Support Requirements.

### **3.7 In Situ Respiration Test**

The objective of the *in situ* respiration test is to determine the rate at which soil bacteria degrade petroleum hydrocarbons. Respiration tests will be performed at selected MPs where bacteria biodegradation of hydrocarbons is indicated by low oxygen levels and elevated carbon dioxide concentrations in the soil gas. A lcfm pump will be used to inject air into the selected MP depth intervals containing low levels (<2%) of oxygen. A 20-hour air injection period will be used to oxygenate local contaminated soils. At the end of the 20-hour air injection period, the air supply will be cut off, and oxygen and carbon dioxide levels will be monitored for the following 48 to 72 hours. The decline in oxygen and increase in carbon dioxide concentrations over time will be used to estimate rates of bacterial degradation of fuel residuals. Helium will also be injected at one or two MPs to estimate oxygen loss due to diffusion rather than biological respiration. Additional details on the *in situ* respiration test are found in Section 5.7 of the protocol document.

### **3.8 Air Permeability Test**

The objective of the air permeability test is to determine the extent of the subsurface that can be oxygenated using one air injection VW. Air will be injected into the 4-inch-diameter VW using the blower unit, and pressure response will be measured at each MP with differential pressure gauges to determine the region influenced by the unit. Oxygen will also be monitored in the MPs to verify that oxygen levels in the soil increase as the result of air injection. One air permeability test lasting 4 to 8 hours will be performed.

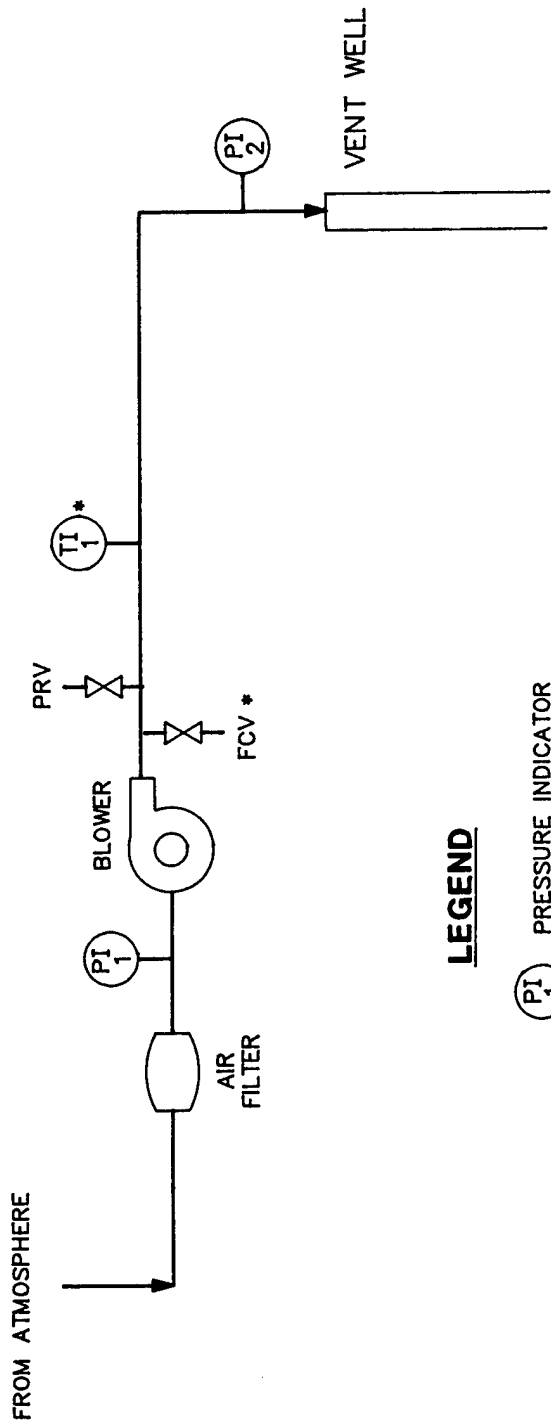

**LEGEND**

- PI 1 PRESSURE INDICATOR
- TI 1 TEMPERATURE INDICATOR
- FCV FLOW CONTROL VALVE
- PRV PRESSURE RELIEF VALVE
- \* OPTIONAL

**FIGURE 3.4**  
**PROPOSED BLOWER SYSTEM**  
**INSTRUMENTATION DIAGRAM**  
**FOR AIR INJECTION**  
**POL STORAGE AREA C**  
**TINKER AFB, OKLAHOMA**

**ENGINEERING-SCIENCE, INC.**  
 Denver, Colorado



### **3.9 Installation of 1-Year Pilot Test Bioventing System**

Long-term bioventing systems will be installed at POL Storage Area C. The base will be requested to provide power, including 230-volt, 30-amp, single-phase service and a breaker box with one 230-volt receptacle and two 110-volt receptacles. Depending on the availability of a base electrician, a base electrician or a licensed electrician subcontracted to ES will assist in wiring the blowers to line power. The blower will be housed in a small, prefabricated shed to provide protection from the weather. The system will be in operation for 1 year, and every 6 months ES personnel will conduct *in situ* respiration tests to monitor the long-term performance of this bioventing system. Weekly system checks will be performed by Tinker AFB personnel. If required, major maintenance of the blower unit will be performed by ES-Denver personnel. Detailed blower system information and a maintenance schedule will be included in the operation and maintenance (O&M) manual provided to the base. More detailed information regarding the test procedures can be found in the protocol document.

### **4.0 EXCEPTIONS TO PROTOCOL PROCEDURES**

The procedures that will be used to measure the air permeability of the soil and *in situ* respiration rates are described in Sections 4 and 5, respectively, of the protocol document (Hinchee et al., 1992). No exceptions to the protocol are anticipated.

### **5.0 BASE SUPPORT REQUIREMENTS**

#### **5.1 Test Preparation**

The following base support is needed prior to the arrival of the drilling subcontractor and the ES pilot test team:

- Assistance in obtaining drilling and digging permits.
- Confirmation of available power source, including 230-volt, 30-amp, single-phase service and a breaker box with one 230-volt receptacle and two 110-volt receptacles on the power panel located near MW-3.
- Provision of any paperwork required to obtain gate passes and security badges for approximately three ES employees, two drillers, and an electrician (if a base electrician is not available). Vehicle passes will be needed for one truck and trailer, and a drill rig.

During the initial testing, the following base support is needed:

- Twelve square feet of desk space and a telephone in a building located as close to the site as practical.
- The use of a facsimile machine for transmitting 15 to 20 pages of test results.
- A decontamination pad where the driller can clean augers between borings.

- Acceptance of responsibility for drill cuttings from VW and MP borings, including any drum sampling to determine hazardous waste status. (If ES is to transfer custody of barrels to another contractor working on the base; assistance in arranging this transfer will also be needed.)

During the 1-year extended pilot test, base personnel will be required to perform the following activities:

- Check the blower system once per week to ensure that it is operating and to record the air injection pressure. ES will provide a brief training session on this procedure.
- If the blower stops working, notify Mr. John Hall or Mr. Doug Downey of ES-Denver, (303) 831-8100; or Mr. Jerry Hansen of AFCEE, (512) 536-4331.
- Arrange site access for an ES technician to conduct *in situ* respiration tests at approximately 6 months and 1 year after the initial pilot test.

## 6.0 PROJECT SCHEDULE

The following schedule is contingent upon approval of this pilot test work plan and completion of base support requirements.

<u>Event</u>	<u>Date</u>
Draft Test Work Plan to AFCEE/Tinker AFB	8 October 1992
Begin Initial Pilot Test	10 November 1992
Interim Results Report	4 January 1993
Respiration Test	April 1993
Final Respiration Test	November 1993

## 7.0 POINTS OF CONTACT

Mr. Jerry Forste  
 OC-AFLC/EMR  
 Bldg. 3333  
 Tinker AFB, OK 73145-5000  
 (405) 734-3058

Major Ross Miller/Mr. Jerry Hansen  
AFCEE/EST  
Brooks AFB, TX 78235-5000  
(512) 536-4331

Mr. Doug Downey  
Engineering-Science, Inc.  
1700 Broadway, Suite 900  
Denver, CO. 80290  
(303) 831-8100  
Fax (303) 831-8208

## 8.0 REFERENCES

Engineering-Science, Inc. 1992. *Field Sampling Plan for AFCEE Bioventing*. Denver, Colorado.

Hinchee, R.E., Ong, S.K., Miller, R.N., Downey, D.C., Frandt, R. 1992. *Test Plan and Technical Protocol for a Field Treatability Test for Bioventing*. January.

Water & Soil Consultants, Inc., 1992. *Draft Remedial Investigation Report, POL Site, Area "C" 3700 Fuel Yard*. May.

**PART II**  
**DRAFT INTERIM PILOT TEST RESULTS REPORT**  
**FOR**  
**POL STORAGE AREA C**  
**TINKER AFB, OKLAHOMA**

**December 1992**

**Prepared for:**

**Air Force Center for Environmental Excellence**  
**Brooks AFB, Texas**

**and**

**Oklahoma City Air Force Logistics Center**  
**Environmental Management**  
**Tinker AFB, Oklahoma**

**by:**

**Engineering-Science, Inc.**  
**1700 Broadway, Suite 900**  
**Denver, Colorado**

## CONTENTS

### PART II - DRAFT INTERIM PILOT TEST RESULTS REPORT FOR POL STORAGE AREA C TINKER AFB, OKLAHOMA

	<u>Page</u>
1.0 Pilot Test Design and Construction .....	II-1
1.1 Air Injection Vent Well .....	II-1
1.2 Monitoring Points .....	II-5
1.3 Blower Unit.....	II-5
2.0 Pilot Test Soil and Soil Gas Sampling Results .....	II-5
2.1 Sampling Results.....	II-5
2.2 Exceptions to Test Protocol Document Procedures .....	II-8
2.3 Field QA/QC Results .....	II-8
3.0 Pilot Test Results .....	II-8
3.1 Initial Soil Gas Chemistry .....	II-8
3.2 Air Permeability.....	II-11
3.3 Oxygen Influence .....	II-11
3.4 <i>In Situ</i> Respiration Rates.....	II-11
3.5 Potential Air Emissions .....	II-24
4.0 Recommendations .....	II-24
5.0 References.....	II-25
Appendix A Geologic Boring Logs and Chain-of-Custody Forms	
Appendix B O&M Checklist	

## TABLES

<u>No.</u>	<u>Title</u>	<u>Page</u>
2.1	Soil and Soil Gas Laboratory Analytical Results.....	II-9
3.1	Initial Soil Gas Chemistry.....	II-10
3.2	Influence of Air Injection at Vent Well on Monitoring Point Oxygen Levels.....	II-15
3.3	Oxygen Utilization Rates.....	II-22

## FIGURES

<u>No.</u>	<u>Title</u>	<u>Page</u>
1.1	As-Built Vent Well, Monitoring Point, and Blower Locations.....	II-2
1.2	Hydrogeologic Cross Section.....	II-3
1.3	As-Built Injection Vent Well Construction Detail .....	II-4
1.4	As-Built Monitoring Point Construction Detail.....	II-6
1.5	As-Built Blower System for Air Injection.....	II-7
3.1	Permeability Test Results Monitoring Point MPA.....	II-12
3.2	Permeability Test Results Monitoring Point MPB.....	II-13
3.3	Permeability Test Results Monitoring Point MPC.....	II-14
3.4	Respiration Test: Monitoring Point MPA-5.....	II-16
3.5	Respiration Test: Monitoring Point MPA-15.....	II-17
3.6	Respiration Test: Monitoring Point MPB-10.....	II-18
3.7	Respiration Test: Monitoring Point MPB-15.....	II-19
3.8	Respiration Test: Monitoring Point MPC-10.....	II-20
3.9	Respiration Test: Monitoring Point MPC-15.....	II-21
3.10	Oxygen and Helium Concentrations Monitoring Point MPB-15 .....	II-23

**PART II**  
**DRAFT**  
**INTERIM PILOT TEST RESULTS REPORT**  
**FOR POL STORAGE AREA C**  
**TINKER AFB, OKLAHOMA**

An initial bioventing pilot test was completed at Petroleum, Oils, and Lubricants (POL) Storage Area C at Tinker Air Force Base (AFB), Oklahoma during the period of 10 through 19 November 1992. The purpose of this Part II report is to describe the results of the initial pilot test at POL Storage Area C and to make specific recommendations for extended testing to determine the long-term impact of bioventing on site contaminants. Descriptions of the history, geology, and contamination in POL Storage Area C are contained in Part I, the Bioventing Pilot Test Work Plan.

## **1.0 PILOT TEST DESIGN AND CONSTRUCTION**

Installation of an air injection vent well (VW) and three vapor monitoring points (MPs) took place on 11 and 12 November 1992. Drilling services were provided by A.W. Pool, Inc. of Clinton, Oklahoma, and well installation and soil sampling was directed by Mr. John Hall, the Engineering-Science, Inc. (ES) site manager. The following sections describe the final design and installation of the bioventing system at this site.





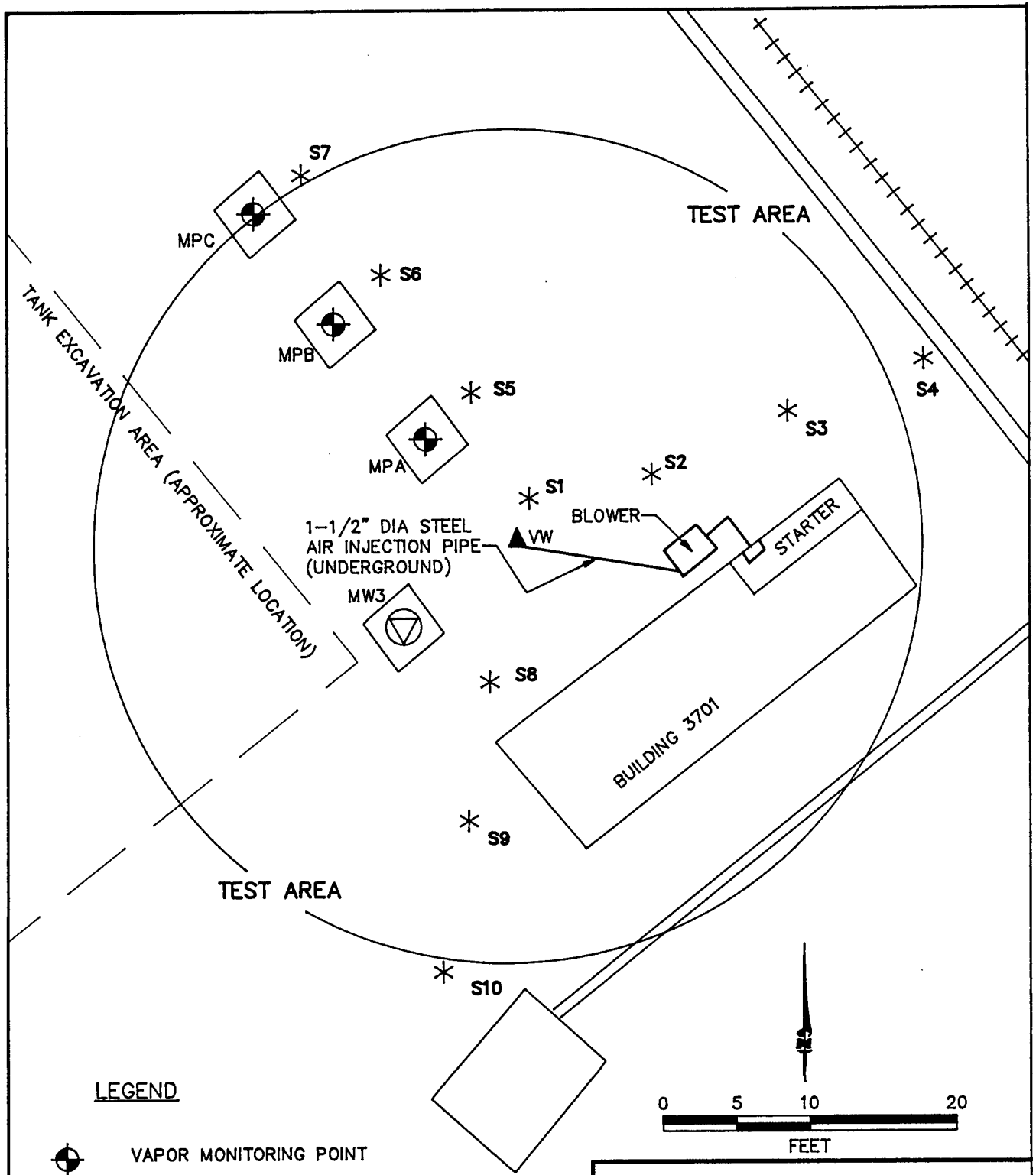

One VW, three MPs, and a blower unit were installed at POL Storage Area C. The locations of the VW, MPs, and blower unit were changed slightly from those proposed in the work plan to avoid interference with an abandoned pipeline. Figures 1.1 and 1.2, respectively, depict the locations of and hydrogeologic cross sections for the VW and MPs completed at the site. Boring logs for the MPs and VW are included in Appendix A. The background MP for this site was a multiple-depth MP installed by Battelle in March 1992.

### **1.1 Air Injection Vent Well**

The air injection VW was installed following procedures described in the Air Force Center for Environmental Excellence (AFCEE) bioventing protocol document (Hinchee et al., 1992). Figure 1.3 shows construction details for the VW. The VW was installed in highly contaminated soils with the screened interval extending from 7 feet below ground surface (bgs) to the groundwater surface at 17 feet bgs. The VW was constructed using 4-inch-diameter, schedule 80 polyvinyl

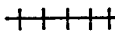

**LEGEND**

-  VAPOR MONITORING POINT
-  CENTRAL VENT WELL
-  EXISTING MONITORING WELL
-  AIR EMISSION MEASUREMENT LOCATION
-  RAILROAD
-  ABOVE GROUND FUEL PIPELINE

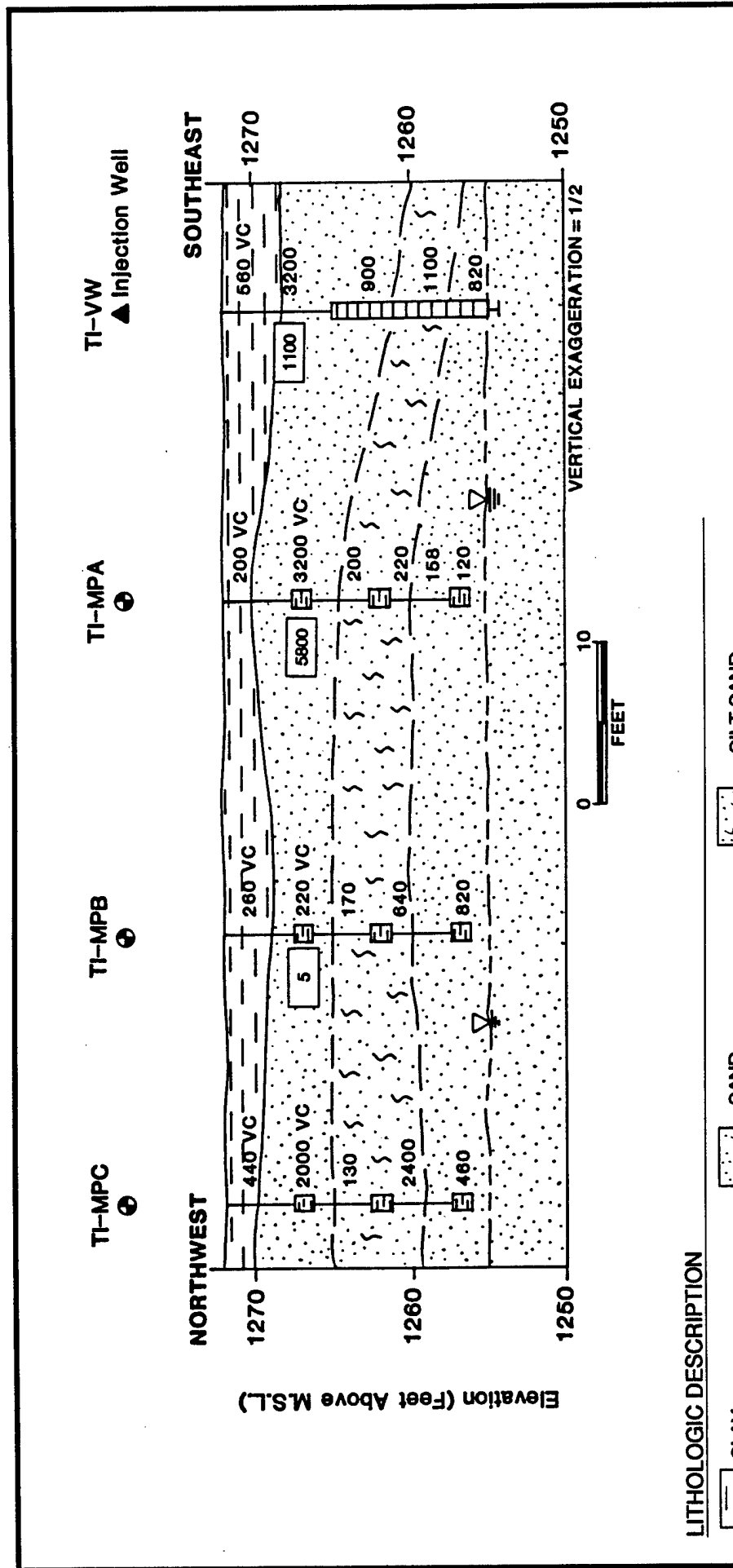

**FIGURE 1.1**  
**AS-BUILT VENT WELL,  
 MONITORING POINT, AND  
 BLOWER LOCATIONS  
 POL STORAGE AREA C**

**TINKER AFB, OKLAHOMA**

**ENGINEERING-SCIENCE, INC.**  
 Denver, Colorado





**LITHOLOGIC DESCRIPTION**

- CLAY
- SAND
- SILT SAND

**LEGEND**

- TI-MPA MONITORING POINT
- TI-VW INJECTION VENT WELL
- 440 FIELD SCREENING RESULTS FOR TOTAL VOLATILE HYDROCARBONS (ppmv)
- LABORATORY RESULTS FOR SOIL TOTAL PETROLEUM HYDROCARBONS (mg/kg)
- VC VISIBLE CONTAMINATION
- GROUNDWATER ELEVATION
- GEOLOGIC CONTACT, DASHED WHERE INFERRED
- MONITORING POINT SCREENED INTERVAL
- SCREENED WELL INTERVAL

**FIGURE 1.2**

**HYDROGEOLOGIC  
CROSS SECTION  
POL STORAGE AREA C**

TINKER AFB, OKLAHOMA  
ENGINEERING-SCIENCE, INC.  
Denver, Colorado



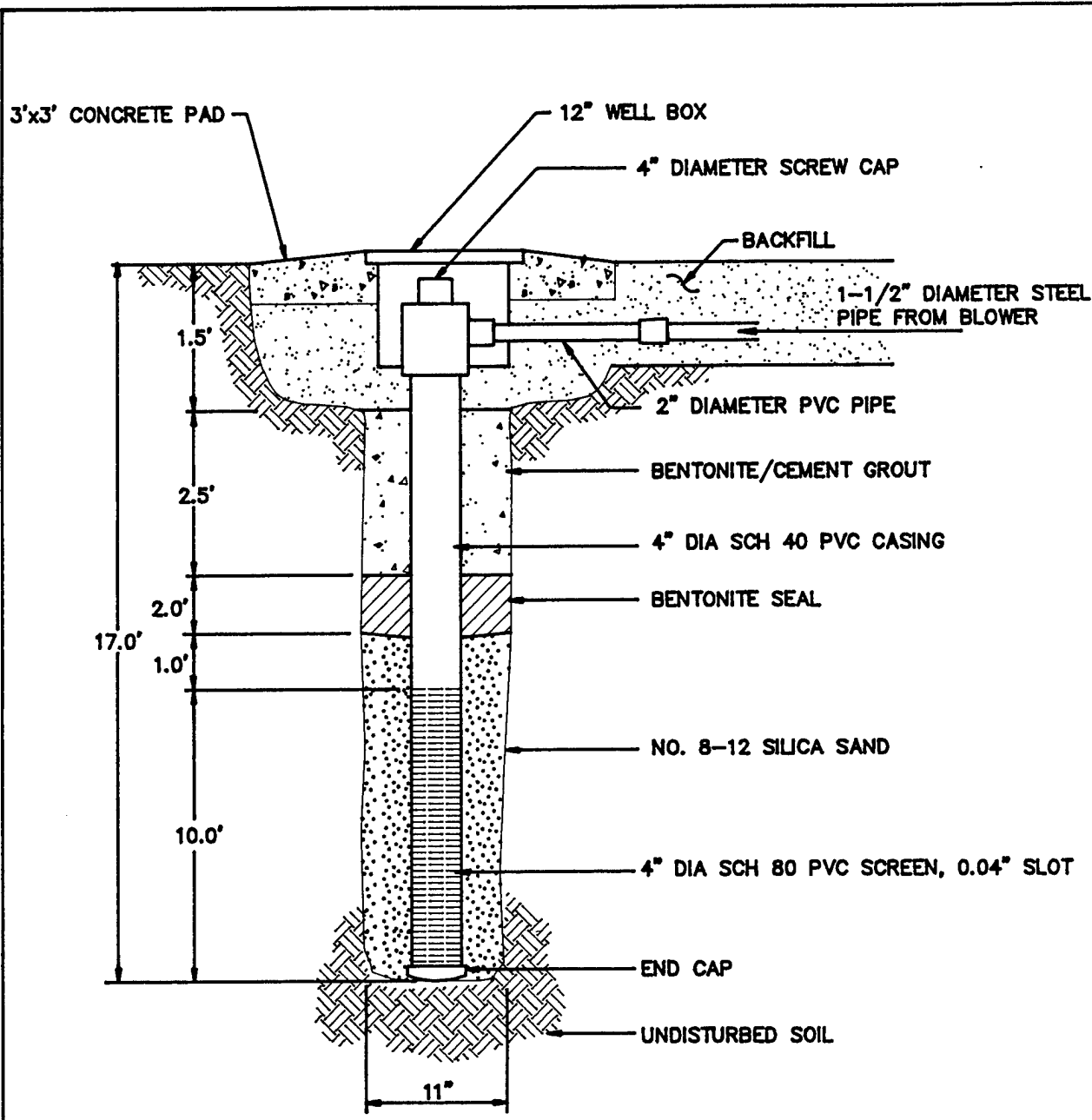

NOT TO SCALE

FIGURE 1.3  
 AS-BUILT INJECTION VENT  
 WELL CONSTRUCTION DETAIL  
 POL STORAGE AREA C

TINKER AFB, OKLAHOMA

ENGINEERING-SCIENCE, INC.  
 Denver, Colorado



chloride (PVC) casing, with 10 feet of 0.04-inch slotted PVC screen installed from 7 to 17 feet bgs. The annular space between the well casing and borehole was filled with 8-12 silica sand from the bottom of the borehole to approximately 1 foot above the well screen. Two feet of bentonite pellets was placed above the sand, hydrated in place, and followed by a bentonite/cement grout to within 1.5 feet of the surface. The top of the well was completed with a 4-inch-diameter PVC tee with a screw cap in a 12-inch flush-mounted box to allow future access to the well.

### **1.2 Monitoring Points**

The MP screens were installed at 5-, 10-, and 15-foot depths. The three MPs (MPA, MPB, and MPC) at this site were constructed as shown in Figure 1.4. Each was constructed using a 6-inch section of 1-inch-diameter PVC well screen and a 0.25-inch PVC riser pipe extending to the ground surface. At the top of each riser, a ball valve and a 3/16-inch hose barb were installed. The top of each MP was completed with a flush-mounted metal well protector set in a 4-foot-square concrete base. Thermocouples were installed at the 5- and 15-foot depths at MPA to measure soil temperature variations.

The existing Battelle multi-depth background MP was utilized as a background MP. This MP is located approximately 4,000 feet north of POL Storage Area C near Building 3507, and is screened at approximately 4, 7, and 10 feet bgs.

### **1.3 Blower Unit**

A 2.5-horsepower Gast<sup>®</sup> regenerative blower unit was used at POL Storage Area C for the initial pilot test, and a 1-horsepower Gast<sup>®</sup> regenerative blower unit was installed at the site for the extended pilot test. Both units were energized by 230-volt, single-phase, 30-amp line power from a newly installed breaker in the existing breaker box. The 1-horsepower extended pilot test blower was configured to inject approximately 18 standard cubic feet per minute (scfm) for the extended pilot test. The configuration, instrumentation, and specifications for the initial pilot test and extended pilot test units are shown on Figure 3.5 (Part I) and Figure 1.5, respectively. Prior to departing from the site, ES engineers provided an operations and maintenance (O&M) briefing checklist and blower maintenance manual to base personnel. A copy of the checklist is provided in Appendix B.

## **2.0 PILOT TEST SOIL AND SOIL GAS SAMPLING RESULTS**

### **2.1 Sampling Results**

Soils at this site consist of silty clay in the upper 2 to 4 feet overlying weathered sandstone (Figure 1.2). The weathered sandstone is generally very friable and consists of fine- to very fine-grained sand, with the grain size increasing with depth. A silty layer was encountered from approximately 7 to 12 feet bgs, and the sandstone was slightly to moderately cemented below about 15 feet bgs. Groundwater occurred at depths between 16.5 and 17 feet bgs in the VW and in nearby existing monitoring wells. Boring logs for the MPs and VW are included in Appendix A.

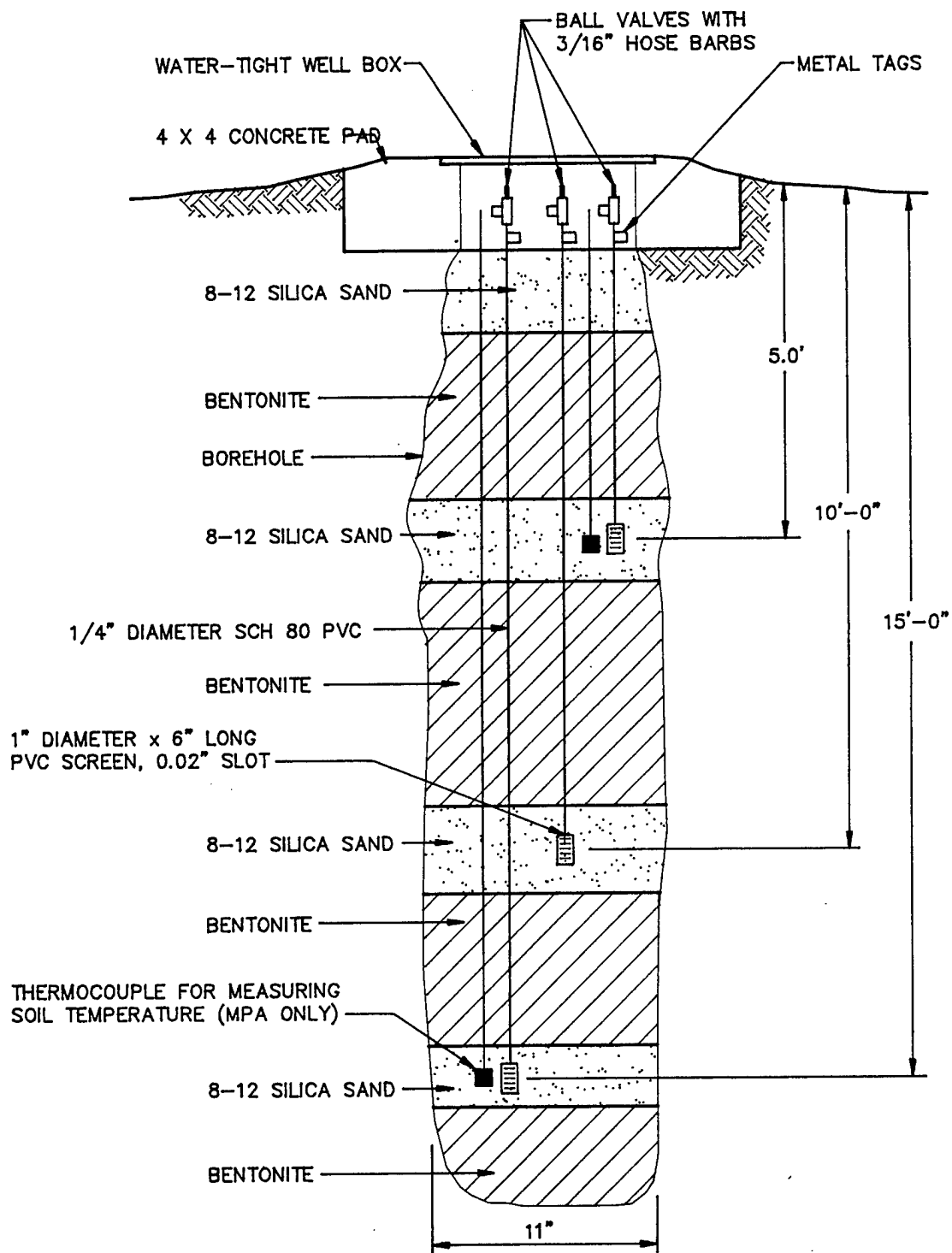

FIGURE 1.4

AS-BUILT MONITORING POINT  
CONSTRUCTION DETAIL  
POL STORAGE AREA "C"

TINKER AFB, OKLAHOMA

ENGINEERING-SCIENCE, INC.  
Denver, Colorado

ES

**LEGEND**

- ① INLET AIR FILTER - SOLBERG F-18P-150
- ② VACUUM GAGE (in H<sub>2</sub>O)
- ③ 1 HP BLOWER - GAST R4110N-50
- ④ AUTOMATIC PRESSURE RELIEF VALVE
- ⑤ MANUAL PRESSURE RELIEF (BLEED) VALVE - 1 1/2" GATE
- ⑥ PRESSURE GAGE (in H<sub>2</sub>O)
- ⑦ TEMPERATURE GAGE (F)
- ⑧ STARTER - FURNAS 14CSD33DA NEMA 3
- ⑨ BREAKER BOX - 230V/SINGLE PHASE/30 AMP

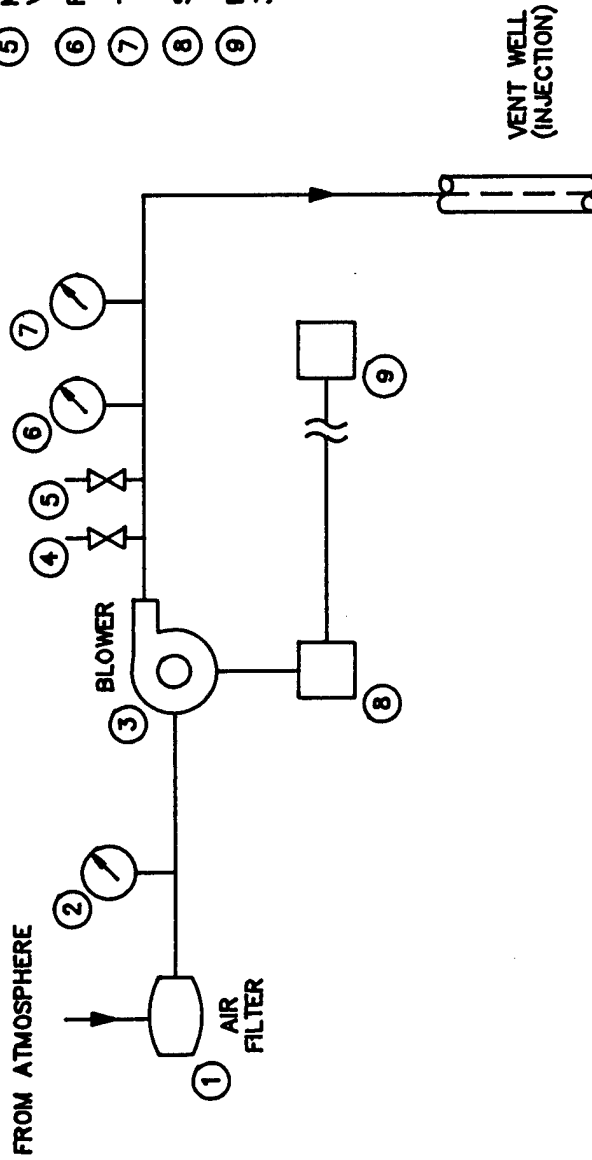

**FIGURE 1.5**  
**AS-BUILT**  
**EXTENDED PILOT TEST BLOWER**  
**SYSTEM FOR AIR INJECTION**  
**POL STORAGE AREA "C"**

TINKER AFB, OKLAHOMA

ENGINEERING—SCIENCE, INC.  
 Denver, Colorado

**ES**

Hydrocarbon contamination at this site appears to be confined mainly within the upper 15 feet of soil and weathered sandstone. Contaminated soils were identified based on visual appearance, odor, and volatile organic compound (VOC) field screening results. Heavily contaminated soils were encountered in the VW and all MP boreholes. Soils at these locations had a strong hydrocarbon odor and at MPB appeared to be saturated with fuel immediately above the cemented zone at 15 feet bgs. Contamination decreased noticeably below about 15 feet bgs, where the sandstone was cemented. No free product was detected on the groundwater surface.

Soil samples for laboratory analysis were collected from continuous-core split-spoon samplers with 2.5-inch-diameter brass liners. Soil samples were screened for VOCs using a photoionization detector to determine the presence of contamination and to select soil samples for laboratory analysis. Soil samples for laboratory analysis were collected from a depth of 5 feet from MPA, MPB, and the VW. Soil gas samples were collected by extracting soil gas from the completed VW, at 5 feet from MPA, and at 15 feet from MPC.

Soil samples were shipped via Federal Express® to the ES Berkeley laboratory for chemical and physical analysis. Soil samples were analyzed for total recoverable petroleum hydrocarbons (TRPH); benzene, toluene, ethylbenzene and xylenes (BTEX); iron; alkalinity; total Kjeldahl nitrogen (TKN); and several physical parameters. Soil gas samples were shipped via Federal Express® to Air Toxics, Inc. in Rancho Cordova, California for total volatile hydrocarbon (TVH) and BTEX analysis. The results of these analyses are provided in Table 2.1.

## **2.2 Exceptions To Test Protocol Document Procedures**

Procedures described in the protocol document (Hinchee et al., 1992) were used to complete treatability tests at both sites. The only exception was that the bentonite seals in the MPs were hydrated in place instead of using a bentonite slurry to assure long-term integrity of the seals.

## **2.3 Field QA/QC Results**

Field quality assurance/quality control (QA/QC) samples were not collected or required at this site.

## **3.0 PILOT TEST RESULTS**

### **3.1 Initial Soil Gas Chemistry**

Prior to initiating any air injection, all MPs were purged until oxygen levels had stabilized, and initial oxygen, carbon dioxide, and TVH concentrations were sampled using portable gas analyzers, as described in the technical protocol document (Hinchee et al., 1992). At all MP screened intervals and at the VW, microorganisms had depleted soil gas oxygen supplies, indicating significant soil contamination. Table 3.1 summarizes the initial soil gas chemistry. TRPH data are also provided to demonstrate the relationship between low oxygen levels and contaminated soils.

**TABLE 2.1**  
**SOIL AND SOIL GAS LABORATORY ANALYTICAL RESULTS**  
**POL STORAGE AREA C**  
**TINKER AFB, OKLAHOMA**

Analyte (Units) <sup>a/</sup>	Sample Location-Depth (feet below ground surface)		
<u>Soil Gas Hydrocarbons</u>	<u>VW 7-17</u>	<u>MPA-5</u>	<u>MPC-5</u>
TVH (ppmv)	940	3500	30,000
Benzene (ppmv)	ND <sup>b/</sup>	100	59
Toluene (ppmv)	6.3	120	180
Ethylbenzene (ppmv)	1.1	17	15
Xylenes (ppmv)	3.2	55	51
<u>Soil Hydrocarbons</u>	<u>VW-5</u>	<u>MPA-5</u>	<u>MPB-5</u>
TRPH (mg/kg)	1100	5800	5
Benzene (mg/kg)	ND	4.3	ND
Toluene (mg/kg)	120	15.0	ND
Ethylbenzene (mg/kg)	140	19.0	ND
Xylenes (mg/kg)	130	120	ND
<u>Soil Inorganics</u>			
Iron (mg/kg)	3020	1740	4860
Alkalinity (mg/kg as CaCO <sub>3</sub> )	ND	ND	ND
pH (units)	7.2	7.2	7.6
TKN (mg/kg)	54	26	ND
Phosphates (mg/kg)	67	58	40
<u>Soil Physical Parameters</u>			
Moisture (% wt.)	7.8	8.9	7.8
Gravel (%)	0.0	0.0	0.0
Sand (%)	74	74	73
Silt (%)	19	19	19
Clay (%)	7	7	8

a/ TRPH = total recoverable petroleum hydrocarbons; TVH = total volatile hydrocarbons; mg/kg = milligrams per kilogram, ppmv = parts per million, volume per volume; CaCO<sub>3</sub> = calcium carbonate; TKN = total Kjeldahl nitrogen.

b/ ND = not detected.

**TABLE 3.1**  
**INITIAL SOIL GAS CHEMISTRY**  
**POL STORAGE AREA C**  
**TINKER AFB, OKLAHOMA**

Sample Location	Depth (ft)	O <sub>2</sub> (%)	CO <sub>2</sub> (%)	TVH (ppmv) <sup>a/</sup>	TPH (mg/kg) <sup>b/</sup>
MPA	5	0.0	10.5	17,600	5,800
MPB	5	0.0	9.9	11,200	5
MPC	5	0.0	8.8	6,200	NS <sup>c/</sup>
MPA	10	0.0	9.9	13,800	NS
MPB	10	0.0	10.8	>20,000	NS
MPC	10	0.0	10.1	>20,000	NS
MPA	15	0.0	9.6	14,800	NS
MPB	15	0.0	10.8	>20,000	NS
MPC	15	1.5	8.9	>20,000	NS
VW	7-17	2.5	8.8	4,000	1,100 <sup>d/</sup>
Background	2.3-4.3	11.0	6.9	400	NS
	5.7-7.3	4.0	6.5	400	NS
	8.7-10	9.9	4.8	360	NS

- a/ PID field screening results.
- b/ Laboratory results.
- c/ NS=not sampled.
- d/ Sample collected from a depth of 5 feet.

### 3.2 Air Permeability

An air permeability test was conducted according to protocol document procedures. Air was injected into the VW for 5.5 hours at a rate of approximately 34 scfm and an average pressure of 60 inches of water. The pressure response at each MP is shown in Figure 3.1 through 3.3. The pressure measured at the MPs increased gradually during the period of air injection and, at most MPs, reached maximum pressure within 4 or 5 hours. Due to the slow pressure response, the dynamic method of determining air permeability, using the HyperVentilate<sup>®</sup> model, was selected. Using HyperVentilate<sup>®</sup>, soil gas permeability values of between 9 and 23 darcys, typical for fine sand soils, were calculated for this site. A radius of pressure influence of at least 28 feet was observed at the 5-, 10-, and 15-foot depths.

### 3.3 Oxygen Influence

The depth and radius of oxygen increase in the subsurface resulting from air injection into the central VW during pilot testing is the primary design parameter for full-scale bioventing systems. Optimization of full-scale and multiple VW systems requires pilot testing to determine the volume of soil that can be oxygenated at a given flow rate and VW screen configuration.

Table 3.2 presents the change in soil gas oxygen levels that occurred during a 5.5-hour air injection test at the site. This relatively brief air injection period at 34 scfm produced changes in soil gas oxygen levels at all nine MP screened intervals. Based on measured pressure response, which is an indicator of long-term oxygen transport, and changes in oxygen levels, it is anticipated that the radius of influence for a long-term bioventing system at this site will exceed 28 feet at all depths. Monitoring during the extended pilot test at this site will better define the effective treatment radius.

### 3.4. In Situ Respiration Rates

The *in situ* respiration test was performed by injecting air (oxygen) into four MP screened intervals (MPA-5, MPB-10, MPB-15, and MPC-10) for a 20-hour period. Oxygen loss and other changes in soil gas composition over time were then measured at these and at two additional points (MPA-15 and MPC-15) which had oxygen levels exceeding 18 percent following the air permeability test. Oxygen, TVH, and carbon dioxide were measured for a period of 69 hours following air injection. The measured oxygen loss was then used to calculate the biological oxygen utilization rate. The results of *in situ* respiration testing at this site are presented in Figures 3.4 through 3.9. Table 3.3 provides a summary of the oxygen utilization rates.

A 6-percent mixture of helium in air was injected into the MPB-15 screened interval, and then the loss of helium was measured for 69 hours following air injection. Because helium is a conservative, inert gas, the change in helium concentrations over time can be useful in determining the effectiveness of the bentonite seals between MP screened intervals. Figure 3.10 compares oxygen utilization and helium retention at MPB-15. Because the observed helium loss was negligible, and because helium will diffuse approximately three times faster than

Figure 3.1  
 Permeability Test Results  
 Monitoring Point MPA: r = 9 feet  
 POL Storage Area C  
 Tinker AFB, Oklahoma

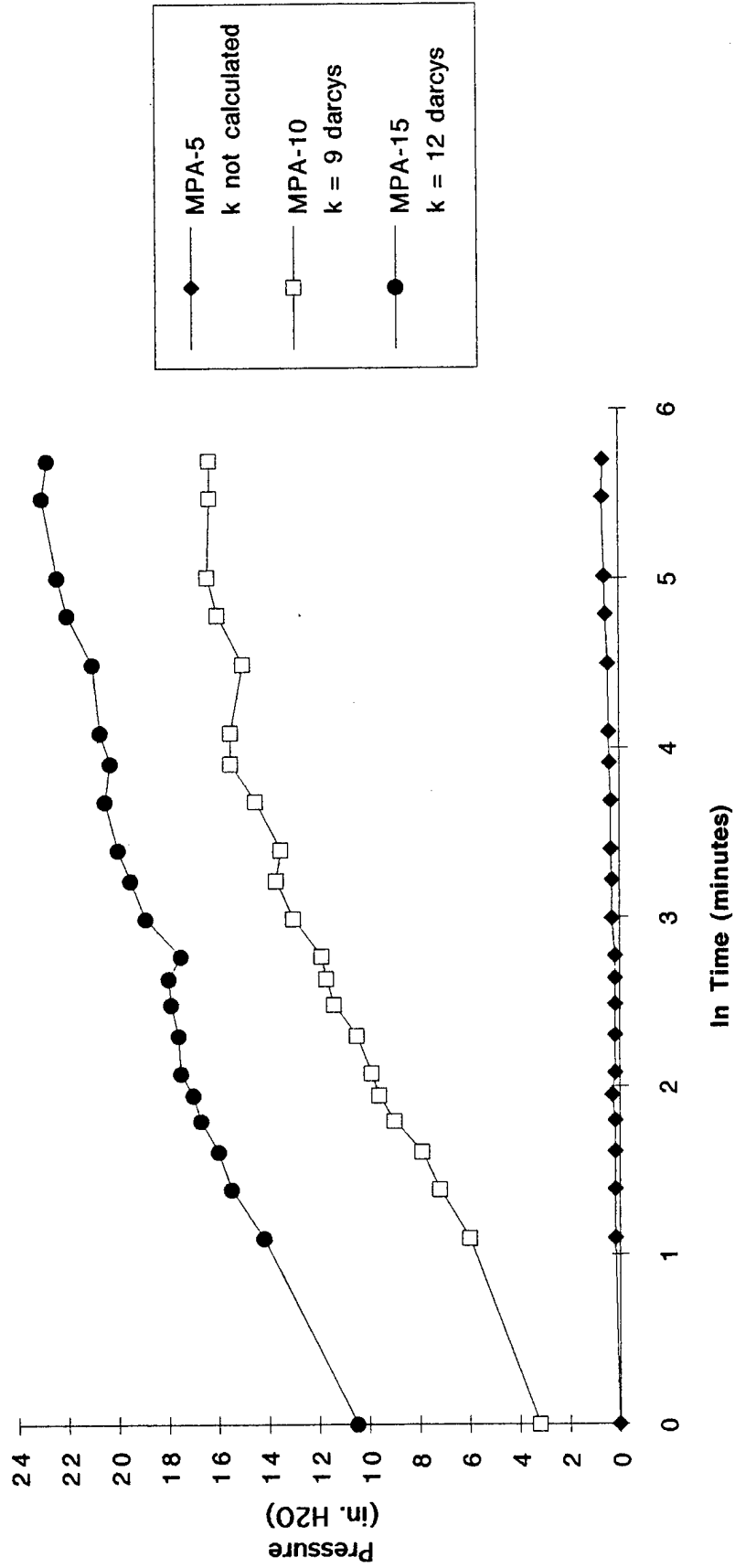

Figure 3.2  
 Permeability Test Results  
 Monitoring Point MPB: r = 19 feet  
 POL Storage Area C  
 Tinker AFB, Oklahoma

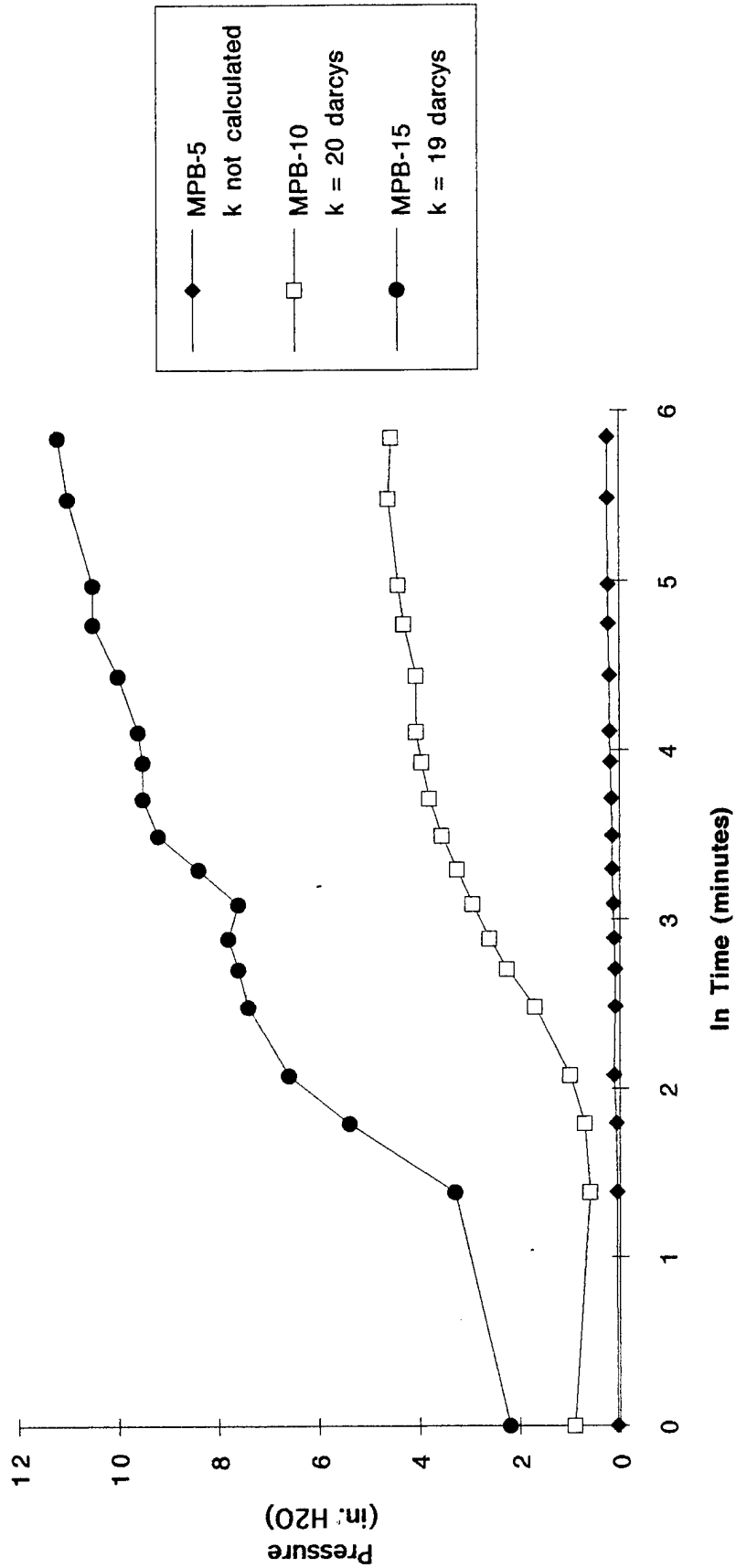
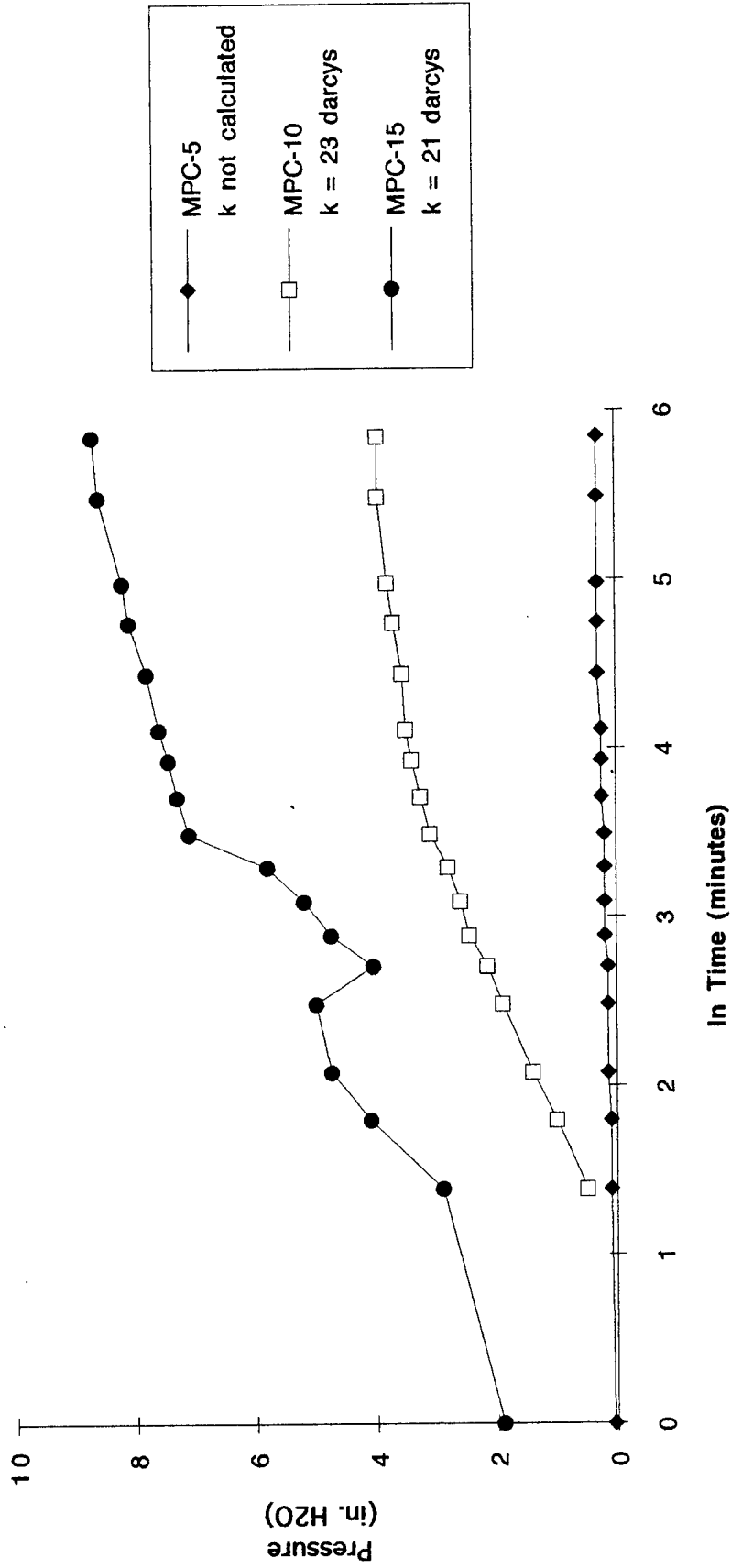

Figure 3.3  
 Permeability Test Results  
 Monitoring Point MPC: r = 28 feet  
 POL Storage Area C  
 Tinker AFB, Oklahoma



**TABLE 3.2**  
**INFLUENCE OF AIR INJECTION AT VENT WELL**  
**ON MONITORING POINT OXYGEN LEVELS**  
**POL STORAGE AREA C**  
**TINKER AFB, OKLAHOMA**

MP	Distance From VW (ft)	Depth(ft)	Initial O <sub>2</sub> (%)	Final O <sub>2</sub> (%)a/
A	9	5	0.0	18.2
B	19	5	0.0	0.2
C	28	5	0.0	1.5
A	9	10	0.0	17.9
B	19	10	0.0	1.2
C	28	10	0.0	1.2
A	9	15	0.0	20.1
B	19	15	0.0	18.0
C	28	15	1.5	14.0

a/ Reading taken at end of 5.5-hour air permeability test.

Figure 3.4  
 Respiration Test  
 Monitoring Point MPA-5  
 POL Storage Area C  
 Tinker AFB, OK

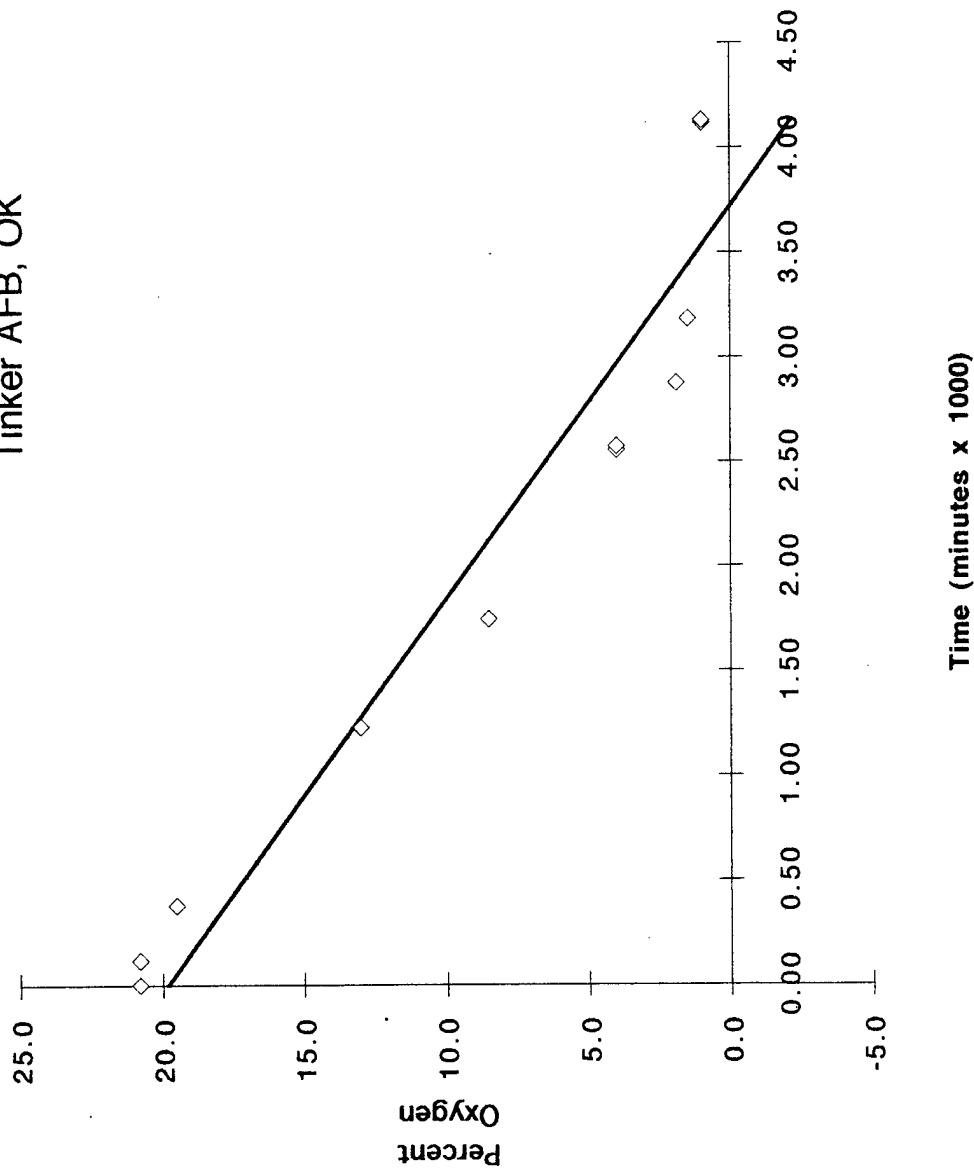

Figure 3.5  
 Respiration Test  
 Monitoring Point MPA-15  
 POL Storage Area C  
 Tinker AFB, OK

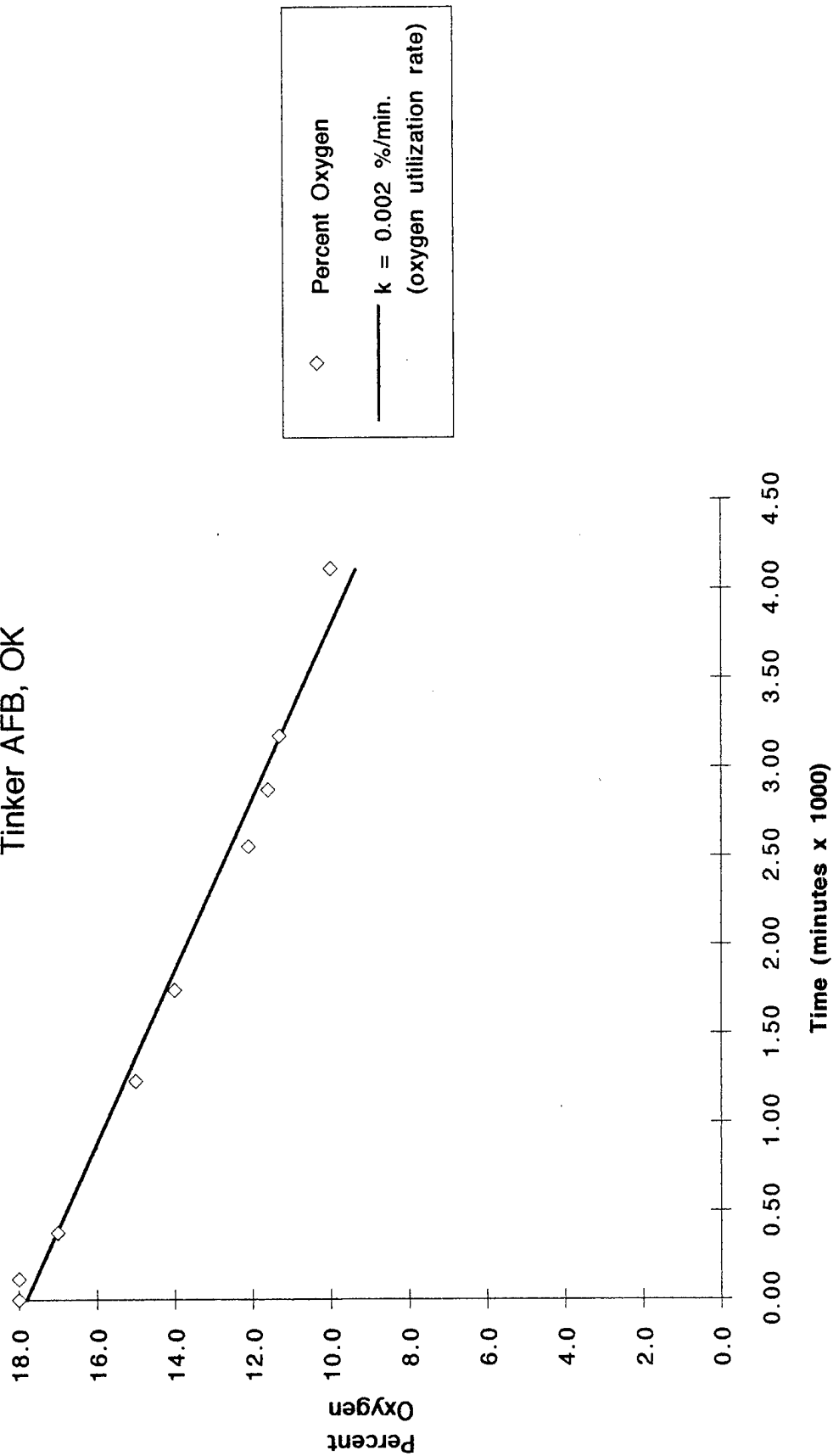

Figure 3.6  
Respiration Test  
Monitoring Point MPB-10  
POL Storage Area C  
Tinker AFB, OK

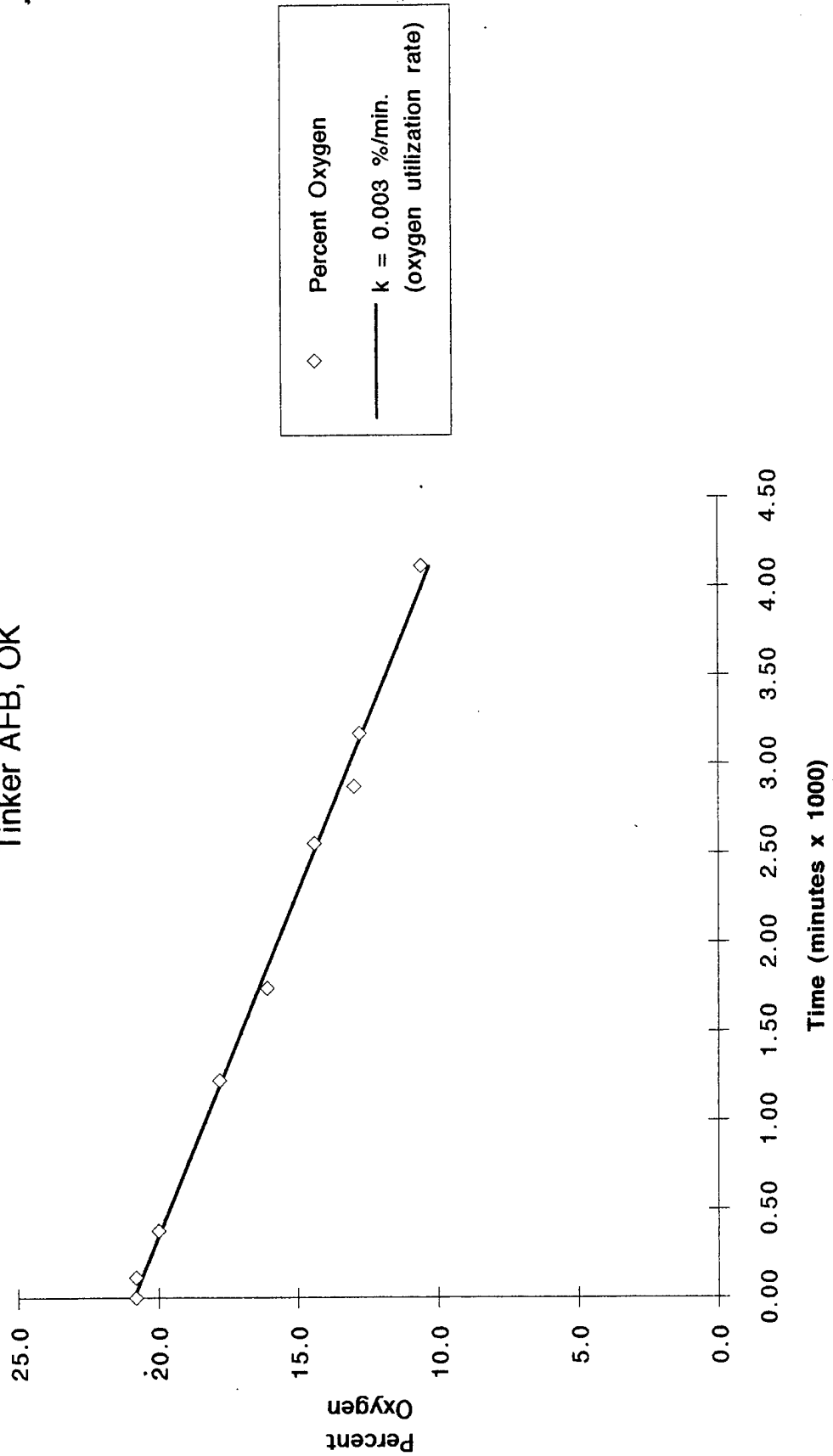

Figure 3.7  
Respiration Test  
Monitoring Point MPB-15  
POL Storage Area C  
Tinker AFB, OK

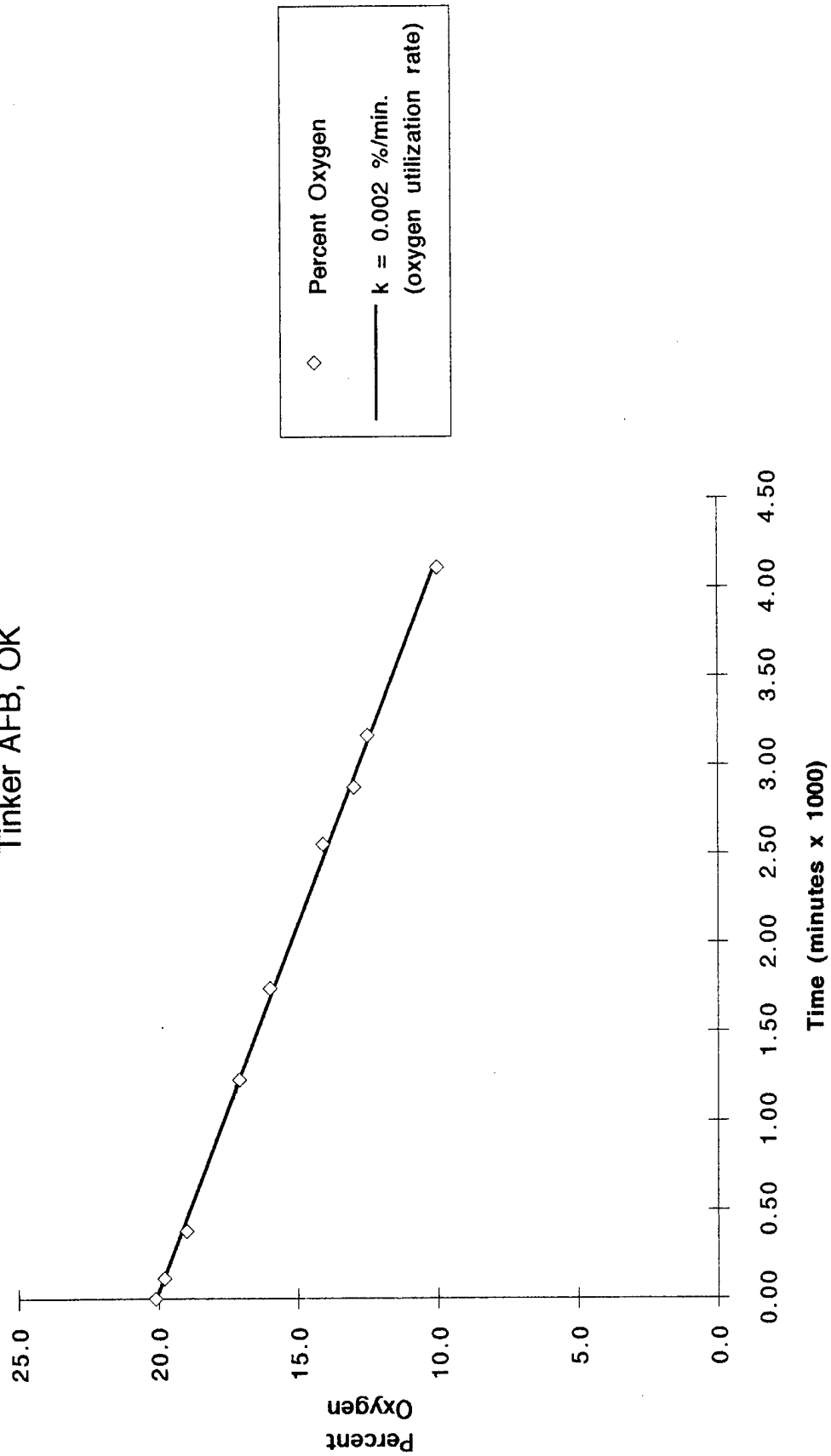

Figure 3.8  
Respiration Test  
Monitoring Point MPC-10  
POL Storage Area C  
Tinker AFB, OK

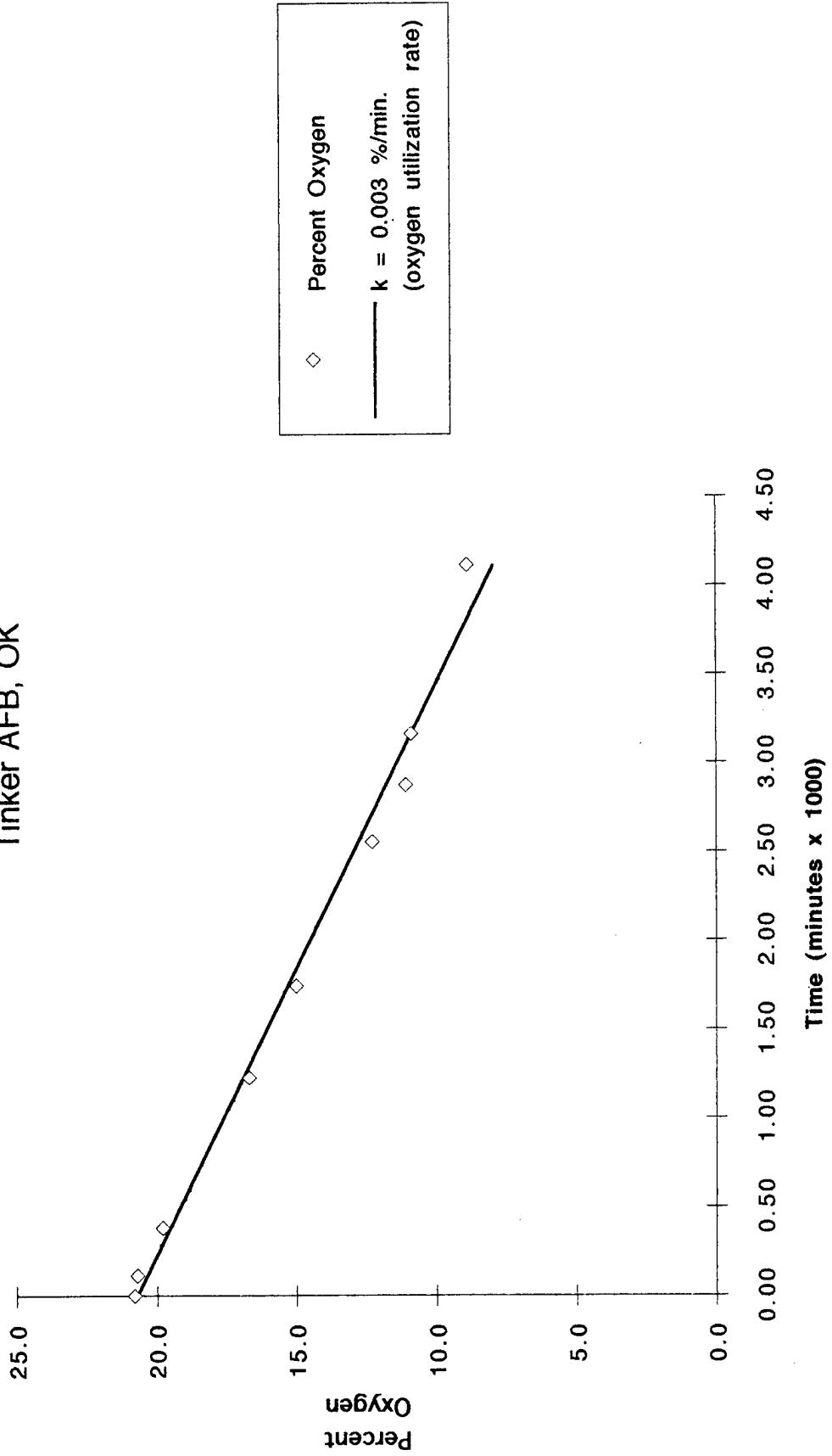
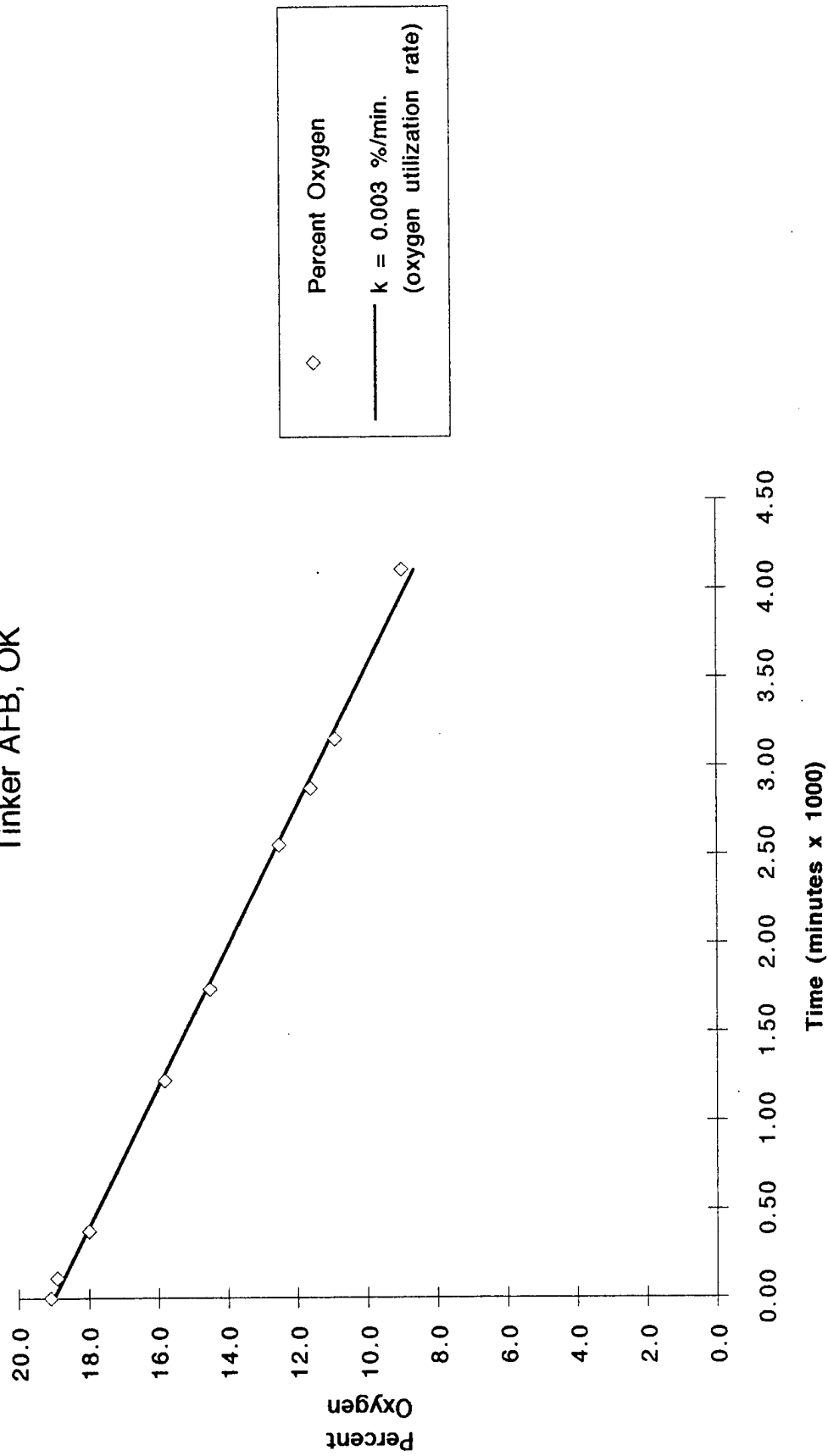

Figure 3.9  
 Respiration Test  
 Monitoring Point MPC-15  
 POL Storage Area C  
 Tinker AFB, OK

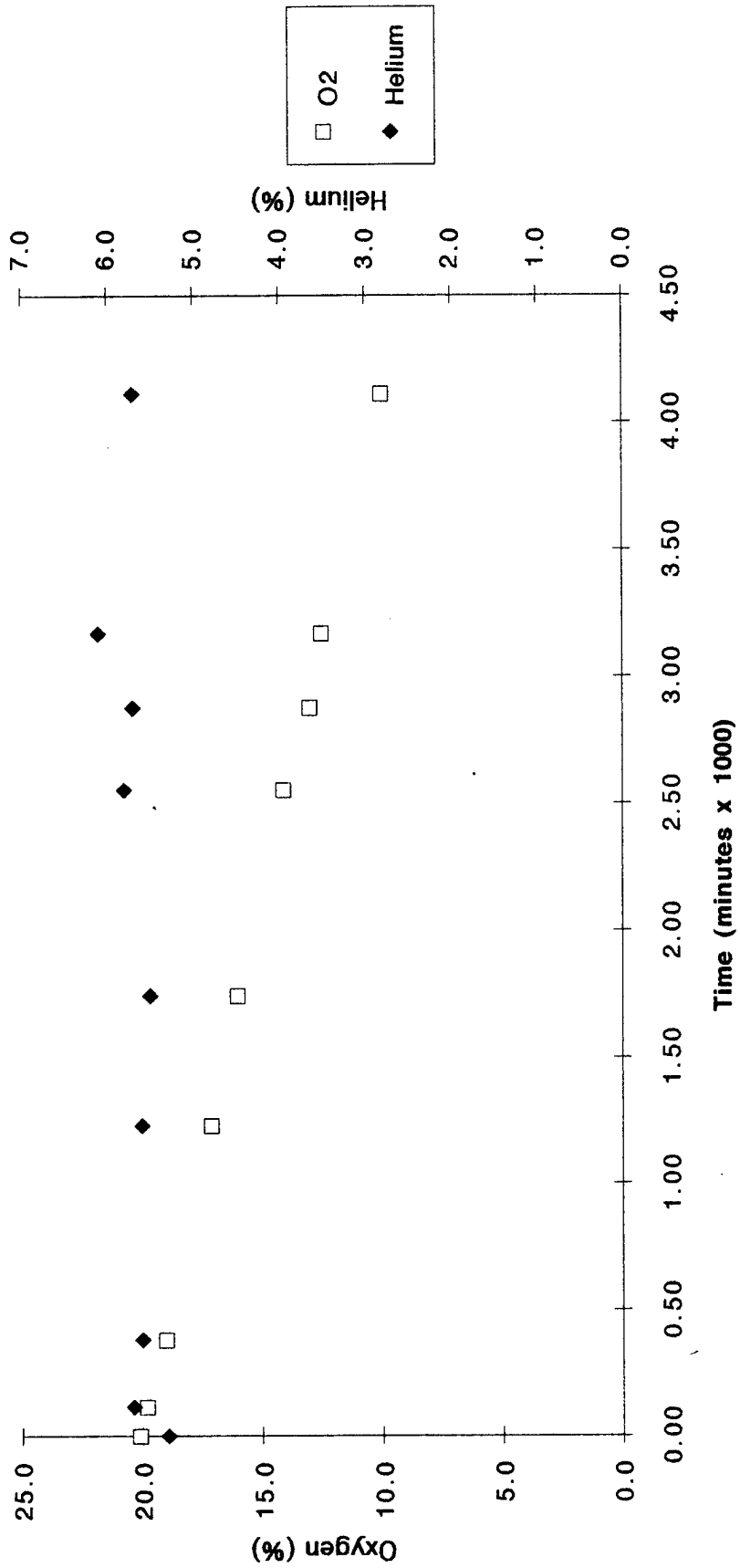

**TABLE 3.3**  
**OXYGEN UTILIZATION RATES**  
**POL STORAGE AREA C**  
**TINKER AFB, OKLAHOMA**

MP	O <sub>2</sub> Loss <sup>a/</sup> (%)	Test Duration (min)	O <sub>2</sub> Utilization <sup>a/</sup> Rate (%/min)
MPA-5	19.8	4,130	0.0053
MPA-15	8.5	4,110	0.0021
MPB-10	10.6	4,110	0.0026
MPB-15	9.9	4,110	0.0024
MPC-10	12.7	4,110	0.0031
MPC-15	10.4	4,110	0.0025

<sup>a/</sup> Values based on best-fit lines (Figures 3.4 through 3.9).

Figure 3.10  
 Respiration Test  
 Oxygen and Helium Concentrations  
 Monitoring Point MPB-15  
 POL Storage Area C  
 Tinker AFB, OK



oxygen, due to oxygen's greater molecular weight, the measured oxygen loss is assumed to be the result of bacterial respiration and not due to diffusion or faulty MP construction.

Results from this test indicate that all six of these points (MPA-5, MPA-15, MPB-10, MPB-15, MPC-10, and MPC-15) had significant soil hydrocarbon contamination. Except for MPC-15, which had an initial oxygen concentration of 1.5 percent, all of these points had initial oxygen concentrations of 0 percent. A soil sample collected from MPA-5 had a TRPH concentration of 5,800 mg/kg. Oxygen loss occurred at moderate rates, ranging from 0.0053 percent per minute at MPA-5 to 0.0021 percent per minute at MPA-15. At MPA-5, the oxygen dropped from 20.8 percent to 0 percent in 4,130 minutes.

Based on these oxygen utilization rates, an estimated 420 to 900 milligrams (mg) of fuel per kilogram (kg) of soil can be degraded each year at this site. This conservative estimate is based on an average air-filled porosity of approximately 0.09 liters per kg of soil, and a ratio of 3.5 mg of oxygen consumed for every 1 mg of fuel biodegraded. Actual rates may exceed these estimates.

### **3.5 Potential Air Emissions**

The long-term potential for air emissions from full-scale bioventing operations at this site is low because of the relatively impermeable clay soil overlying the weathered sandstone and the low injection rates. Emissions should be minimal because accumulated vapors will move slowly outward from the air injection point and will be biodegraded as they move horizontally through the soil.

Air emissions from the soil measured before and during air injection at 10 sampling locations (Figure 1.1) indicate that air injection did not increase TVH emissions. The emission measurements were taken by placing a flux chamber on the ground surface. The air in the chamber was measured continuously for a period of 5 minutes, using a total volatile hydrocarbon analyzer connected to the chamber, and the highest reading was recorded in the field book. The soil surface at each location was leveled and cleared of any debris prior to taking measurements to assure a complete seal between the flux chamber and the soil surface.

## **4.0 RECOMMENDATIONS**

Initial bioventing tests at this site indicate that oxygen has been depleted in the contaminated soils, and that air injection is an effective method of increasing aerobic fuel biodegradation. AFCEE has recommended that air injection continue at this site to determine the long-term radius of oxygen influence and the effect of time, available nutrients, and changing temperatures on fuel biodegradation rates.

A small, 1-horsepower regenerative blower has been installed at the site to continue air injection at a rate of approximately 18 scfm. In April 1993, ES will return to the site to sample and analyze the soil gas and conduct a repeat respiration test. In November 1993, a final respiration test will be conducted, and soil and soil gas samples will be collected from the site to determine the degree of remediation achieved during the first year of *in situ* treatment.

**APPENDIX A  
GEOLOGIC BORING LOGS AND  
CHAIN-OF-CUSTODY FORMS**

## GEOLOGIC BORING LOG

BORING NO.:	TI-VV	CONTRACTOR:	A.W. POOL	DATE SPUD:	11/11/92
CLIENT:	AFCEE	RIG TYPE:	AUGER	DATE CMPL:	11/11/92
JOB NO.:	DE268.16	DRLG METHOD:	HSA	ELEVATION:	1272
LOCATION:	TINKER AFB	BORING DIA.:	11"	TEMP.:	45 °F
GEOLOGIST:	JFH	DRLG FLUID	NONE	WEATHER:	RAIN

COMMENTS:

Elev. (ft.)	Depth (ft.)	Pro-file	US CS	Geologic Description	Sample		Penet. Res.	Remarks TIP = Bkgnd/Reading (ppm)
					No.	Depth(ft)		
	1	---	CL-CH	CLAY, sm silt and f sand, red brn w/gray stain, v moist, strong fuel odor		0-2	C	
		---						TVH=560 (2')
	5	...	SM	SAND, vf, tr silt, red brn, moist, strong odor	VV-5	2-7	C	TVH=3200 (4')
		...						
	10	...				7-12	C	TVH=900 (10')
		...		SAA				
		...		SAND, f-vf, sm silt & silty clay layers <2" thick, red brn, moist, sl odor				
	15	...				12-17	C	TVH=1100 (14')
		...						TVH=820 (16')
		...		Saturated @ 17'-17.5'				--- @17'
	20							TD=17.5'
	25							
	30							
	35							

sl - slight	v - very	f - fine
tr - trace	lt - light	m - medium
sm - some	dk - dark	c - coarse
& - and	bf - buff	BH - Bore Hole
@ - at	brn - brown	SAA - Same As Above
w - with	blk - black	veg - Vegetation

**SAMPLE TYPE**

D - DRIVE  
C - CORE  
G - GRAB

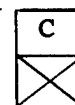

Core recovery  
Core lost

--- Water level drilled

# GEOLOGIC BORING LOG

BORING NO.:	TI-MPA	CONTRACTOR:	A.W. POOL	DATE SPUD:	11/12/92
CLIENT:	AFCEE	RIG TYPE:	AUGER	DATE CMPL:	11/12/92
JOB NO.:	DE268.16	DRLG METHOD:	HSA	ELEVATION:	1272
LOCATION:	TINKER AFB	BORING DIA.:	8"	TEMP.:	40 °F
GEOLOGIST:	JFH	DRLG FLUID	NONE	WEATHER:	SUNNY, WINDY
COMMENTS:					

Elev. (ft.)	Depth (ft.)	Pro-file	US CS	Geologic Description	Sample		Penet. Res.	Remarks TIP = Bkgnd/Reading (ppm)
					No.	Depth(ft)		
	1	---	CL-	CLAY, tr-sm f sand & silt, red brn, gray stain, moist, strong		0-2	C	
		---	CH	fuel odor, gravel @ surface				TVH=200 (2')
	5		SM	SAND, f-vf, red brn, sl odor	MPA-5	2-7	C	TVH=3200 (5')
				SAND, vf, tr-sm silt, red brn, sl odor				
	10			SAA, fine grained		7-12	C	TVH=200 (8')
				SAA, f-vf				TVH=220 (12')
	15			SAA, f-m, no odor		12-16	C	TVH=158 (14')
								TVH=120 (16')
								TD=16'
	20							
	25							
	30							
	35							

sl - slight	v - very	f - fine
tr - trace	lt - light	m - medium
sm - some	dk - dark	c - coarse
& - and	bf - buff	BH - Bore Hole
@ - at	brn - brown	SAA - Same As Above
w - with	blk - black	veg - Vegetation

**SAMPLE TYPE**

D - DRIVE  
C - CORE  
G - GRAB

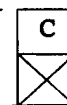

Core recovery  
Core lost

Water level drilled

# GEOLOGIC BORING LOG

BORING NO.:	TI-MPB	CONTRACTOR:	A.W. POOL	DATE SPUD:	11/12/92
CLIENT:	AFCEE	RIG TYPE:	AUGER	DATE CMPL:	11/12/92
JOB NO.:	DE268.16	DRLG METHOD:	HSA	ELEVATION:	1272
LOCATION:	TINKER AFB	BORING DIA.:	8"	TEMP.:	45 °F
GEOLOGIST:	JFH	DRLG FLUID	NONE	WEATHER:	SUNNY, N. WIND

COMMENTS:

Elev. (ft.)	Depth (ft.)	Pro- file	US CS	Geologic Description	Sample		Penet. Res.	Remarks TIP = Bkgnd/Reading (ppm)	
					No.	Depth(ft)			
	1	---	CL- CH	CLAY, tr-sm silt & sand, red-brn, gray stain, sl odor	MPB-5	0-2	C	TVH=260 (2')	
	5	. . .	SM	SAND, f-vf, red brn, blk stain, moist, sl odor	MPB-5	2-7	C	TVH=220 (5')	
				SAA, vf, tr-sm silt, hard drilling					
	10			SAA, f, v hard drilling			7-12	C	TVH=170 (8')
				SAA					TVH=640 (12')
	15	. . .		Saturated w/ water (and fuel?)	MPB-5	12-16	X	TVH=820 (15')	
				15.5 SAA, cemented sandstone				C	TD=16'
	20	. . .			MPB-5				
	25								
	30	. . .			MPB-5				
	35	. . .			MPB-5				

sl - slight	v - very	f - fine
tr - trace	lt - light	m - medium
sm - some	dk - dark	c - coarse
& - and	bf - buff	BH - Bore Hole
@ - at	brn - brown	SAA - Same As Above
w - with	blk - black	veg - Vegetation

**SAMPLE TYPE**

D - DRIVE  
C - CORE  
G - GRAB

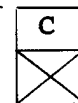

Core recovery  
Core lost

Water level drilled

# GEOLOGIC BORING LOG

BORING NO.:	TI-MPC	CONTRACTOR:	A.W. POOL	DATE SPUD:	11/12/92
CLIENT:	AFCEE	RIG TYPE:	AUGER	DATE CMLP:	11/12/92
JOB NO.:	DE268.16	DRLG METHOD:	HSA	ELEVATION:	1272
LOCATION:	TINKER AFB	BORING DIA.:	8"	TEMP.:	45 °F
GEOLOGIST:	JFH	DRLG FLUID	NONE	WEATHER:	SUNNY, WINDY

COMMENTS:

Elev. (ft.)	Depth (ft.)	Pro- file	US CS	Geologic Description	Sample		Penet. Res.	Remarks TIP = Bkgrnd/Reading (ppm)
					No.	Depth(ft)		
	1	---	CL-	CLAY, sm silt & sand, red-brn, blk stain, v moist, strong odor		0-2	C	
		---	CH					TVH=440 (2')
	5		SM	SAND, f-vf, tr-sm silt, red-tan, blk stain, odor		2-7	C	TVH=2000 (5')
				SAA, vf, sm silt sl odor				
								TVH=130 (8')
	10					7-12	C	
				SAA, f, sl odor				TVH=2400 (12')
	15					12-16	C	TVH=460 (15')
				SAA, strong odor				TD=16'
	20							
	25							
	30							
	35							

sl - slight	v - very	f - fine
tr - trace	lt - light	m - medium
sm - some	dk - dark	c - coarse
& - and	bf - buff	BH - Bore Hole
@ - at	brn - brown	SAA - Same As Above
w - with	blk - black	veg - Vegetation

**SAMPLE TYPE**

D - DRIVE  
C - CORE  
G - GRAB

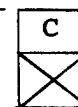

Core recovery  
Core lost

Water level drilled





CHAIN OF CUSTODY RECORD

ES JOB NO.	PROJECT NAME/LOCATION	PRESERVATIVES REQUIRED		ANALYSES REQUIRED		SHIP TO:
		TKN	PHOSPHATE	TCM (CLASS) + HYDROCARBONS	OTHER	
	W.O. 4559					Sequoia Analytical
FIELD CONTACT: <i>Budy Clairborn</i>						
SAMPLERS NAMES & SIGNATURES						
DATE	TIME	FIELD SAMPLE IDENTIFIER	TKN	PHOSPHATE	TCM (CLASS) + HYDROCARBONS	OTHER
11/11/92	1240	TI-KW-5	X	X	4537-1C	211 22 13
11/12/92	0905	TI-MPA-5	X	X	4535-2C	14
↓	1100	TI-MPB-5	X	X	4537-3C	15
REMARKS						
Sub-out						
6 in (Solid) Tubes						
Report request on						
Dry Soil Basis. USE						
MDS FOR REPORTING						
UNITS. REPORT METHOD						
BLANKS, MS/MSD						
10 DAY RT. REPORT TO:						
Tom Paulson E&A						

DATE: 11/13/92 TIME: 1330

ON RECEIPT: CUSTODY SEALS? ; TEMP: °C

SHIPPED VIA: AIRBILL #

RECEIVED FOR LABORATORY BY: *[Signature]* DATE: 11/13/92 TIME: 1330

RELINQUISHED BY: *[Signature]* 11/13/92

K. G. GAVED 11-13-92 1330

**APPENDIX B  
O&M CHECKLIST**

## **SYSTEM MAINTENANCE**

### **B.1 BLOWER/MOTOR MAINTENANCE**

The blower and motor are relatively maintenance free. There is no lubrication required because the blower and motor have sealed bearings. If a blower system is in need of repair, please contact John Hall at (303) 831-8100.

### **B.2 FILTER MAINTENANCE**

To avoid damage caused by passing solids through the blower, an air filter has been installed inline before the blower. By design, Gast® regenerative blowers are able to ingest small quantities of particles without damage. However, continuous ingestion of solids will damage or imbalance the impellers. The inline air filter will prevent solids from entering the blower, and is rated at 99 percent efficiency to 10 microns.

The filter element is a polyester cloth and can be cleaned and reused, or replaced. The filter should be checked weekly for the first two months of operation. The air filter should be cleaned or replaced when the pressure difference across the filter reaches 15 to 20 inches of water. It is the responsibility of Tinker AFB to determine the best schedule for filter cleaning and/or replacement, depending on the results of the initial observations.

The filter can be checked after turning off the blower system. To remove the filter, loosen the clamps, lift the metal top off the air filter, and lift the air filter from the metal housing. When replacing the filter, be careful that the rubber seals remain in place. The filter is manufactured by Solberg Manufacturing, Inc. in Itasca, Illinois. Their phone number is (708) 773-1363. The filters can also be obtained through Fluid Technology, Inc. in Denver, Colorado. The contacts there are Mr. Bob Cook and Mr. Greg Sparks; they can be reached at (303) 233-7400. It is recommended that Tinker AFB keep a spare air filter at the site.

### **B.3 BLOWER PERFORMANCE MONITORING**

To monitor the blower performance, vacuum, pressure, and temperature will be measured. These data will be recorded on the data collection sheets provided. All measurements will be taken at the same time while the system is running.

### **B.3.1 Pressure/Vacuum**

Open the shed roof and record the pressure and vacuum readings directly from the gages in inches of water. Record the measurements on the data collection sheet provided.

### **B.3.2 Temperature**

Open the shed roof and record the temperature readings directly from the gages in degrees Fahrenheit. Record the measurements on the data collection sheet provided.

## **B.4 MONITORING SCHEDULE**

The following monitoring schedule is recommended for this system. During the initial months of operation, more frequent monitoring is recommended to ensure that any start up problems are quickly corrected. Data collection sheets have been provided to record the system data.

### Monitoring Item

Blower vacuum and temperature

### Monitoring Frequency

Weekly for the first 2 months of operation. Tinker AFB personnel then may optimize the schedule depending on the results of initial observations.

