

LOAN DOCUMENT

PHOTOGRAPH THIS SHEET

①

DTIC ACCESSION NUMBER

LEVEL

INVENTORY

Interim Test Results Rpt. - Expanded...

DOCUMENT IDENTIFICATION

Apr 93

DISTRIBUTION STATEMENT A
Approved for Public Release
Distribution Unlimited

DISTRIBUTION STATEMENT

ACCESSION FOR	
NTIS	ORAS
DTIC	TRAC
UNANNOUNCED	
JUSTIFICATION	
BY	
DISTRIBUTION/	
AVAILABILITY CODES	
DISTRIBUTION	AVAILABILITY AND/OR SPECIAL
A-1	

DISTRIBUTION STAMP

DATE ACCESSIONED

DATE RETURNED

20010116 032

DATE RECEIVED IN DTIC

REGISTERED OR CERTIFIED NUMBER

PHOTOGRAPH THIS SHEET AND RETURN TO DTIC-FDAC

H
A
N
D
L
E

W
I
T
H

C
A
R
E

INTERIM TEST RESULTS REPORT AND EXPANDED PILOT TEST DESIGN

For

**BASE EXCHANGE SERVICE STATION
UNDERGROUND STORAGE TANK AREA**
Vandenberg Air Force Base, California

Prepared for

**AIR FORCE CENTER FOR
ENVIRONMENTAL EXCELLENCE**
Brooks Air Force Base, Texas

and

730 CES/CEVR Vandenberg AFB, California

APRIL 1993

Prepared by

ENGINEERING-SCIENCE, INC.
DESIGN ■ RESEARCH ■ PLANNING

199 SOUTH LOS ROBLES AVENUE ■ P.O. BOX 7056 ■ PASADENA, CALIFORNIA 91101

DEFENSE TECHNICAL INFORMATION CENTER
REQUEST FOR SCIENTIFIC AND TECHNICAL REPORTS

Title AFCEE Collection

1. Report Availability (Please check one box)

- This report is available. Complete sections 2a - 2f.
- This report is not available. Complete section 3.

2a. Number of Copies Forwarded

Leach

2b. Forwarding Date

July/2000

2c. Distribution Statement (Please check ONE box)

DoD Directive 5230.24, "Distribution Statements on Technical Documents," 18 Mar 87, contains seven distribution statements, as described briefly below. Technical documents MUST be assigned a distribution statement.

- DISTRIBUTION STATEMENT A: Approved for public release. Distribution is unlimited.
- DISTRIBUTION STATEMENT B: Distribution authorized to U.S. Government Agencies only.
- DISTRIBUTION STATEMENT C: Distribution authorized to U.S. Government Agencies and their contractors.
- DISTRIBUTION STATEMENT D: Distribution authorized to U.S. Department of Defense (DoD) and U.S. DoD contractors only.
- DISTRIBUTION STATEMENT E: Distribution authorized to U.S. Department of Defense (DoD) components only.
- DISTRIBUTION STATEMENT F: Further dissemination only as directed by the controlling DoD office indicated below or by higher authority.
- DISTRIBUTION STATEMENT X: Distribution authorized to U.S. Government agencies and private individuals or enterprises eligible to obtain export-controlled technical data in accordance with DoD Directive 5230.25, Withholding of Unclassified Technical Data from Public Disclosure, 6 Nov 84.

2d. Reason For the Above Distribution Statement (in accordance with DoD Directive 5230.24)

2e. Controlling Office

HQ AFCEE

2f. Date of Distribution Statement Determination

15 Nov 2000

3. This report is NOT forwarded for the following reasons. (Please check appropriate box)

- It was previously forwarded to DTIC on _____ (date) and the AD number is _____
- It will be published at a later date. Enter approximate date if known. _____
- In accordance with the provisions of DoD Directive 3200.12, the requested document is not supplied because: _____

Print or Type Name

Laura Peña

Telephone

210-536-1431

Signature

Laura Peña

AC Number

MDI-04-0620

TABLE OF CONTENTS

1.0	Base Exchange UST Area.....	1
1.1	Pilot Test Design	1
	1.1.1 Air-Injection Vent Well	1
	1.1.2 Monitoring Points.....	6
	1.1.3 Blower Unit.....	6
1.2	Soil and Soil Gas Sampling Results.....	6
1.3	Exceptions to Test Protocol.....	9
1.4	Test Results	9
	1.4.1 Initial Soil Gas Chemistry.....	9
	1.4.2 Soil Gas Permeability	11
	1.4.3 Oxygen Influence.....	12
	1.4.4 In Situ Respiration Rates.....	13
	1.4.5 Potential Air Emissions.....	18
2.0	Recommendations for Expanded Pilot Test	18
	2.1 Concept of Operation.....	18
	2.1.1 Summary of Initial Testing.....	18
	2.1.2 Phase One Soil Venting Operations.....	19
	2.1.3 Phase Two Bioventing Operations.....	19
	2.2 Overview of System Design	22
	2.2.1 Dewatering/Vapor Extraction Wells.....	22
	2.2.2 Soil Gas Extraction System	22
	2.2.3 PADRE® Vapor System	22
	2.2.4 Soil Gas Recirculation and Biodegradation.....	25
	2.3 System Monitoring and Evaluation.....	25
	2.3.1 Air Monitoring Plan	25
	2.3.2 In Situ Biodegradation Monitoring.....	29
	2.3.3 One Year Evaluation	29
3.0	Base Support	29
4.0	Schedule	30
5.0	References	31

APPENDIX A Additional Specifications for Bioventing System Design

APPENDIX B Details on PADRE® Vapor Treatment Unit

TABLES

No.	Title	Page
1.1	Soil and Soil Gas Analytical Results.....	10
1.2	Initial Soil Gas Chemistry.....	11
1.3	Pressure Response Air Permeability Test	12
1.4	Steady-State Influence of Air Injection at Vent Well on Monitoring Point Oxygen Levels	13
1.5	1 Hour Vapor Extraction Test Sample Analytical Results	18
2.1	Sampling Frequency	28

FIGURES

No.	Title	Page
1.1	Site Location BXSS UST Area.....	2
1.2	As Built Vent Wells and Vapor Monitoring Point Locations, BXSS UST Area	3
1.3	Typical Geological Profile	4
1.4	Injection/Vent Well (BXS-MW-12) Construction Detail BXSS UST Area	5
1.5	Monitoring Point Construction Detail BXSS UST Area.....	7
1.6	Blower System Instrumentation Diagram for Air Injection BXSS UST Area.....	8
1.7	Respiration Test: Monitoring Point VA1-MPD	14
1.8	Respiration Test: Monitoring Point BXS-MW-7.....	15
1.9	Respiration Test: Monitoring Point BXS-MW-5.....	16
1.10	Respiration Test Oxygen and Helium Concentrations Monitoring Point VA1-MPD	17
2.1	Phase 1 - Volatiles Reduction.....	24
2.2	Phase 2 - Extended Bioventing	26
2.3	Expanded Dewatering/Bioventing System Plan BXSS UST Area....	20
2.4	Typical Vapor Extraction Dewatering Well	21
2.5	Extended Bioventing System Conceptual Details	23
2.6	Air Monitoring Locations BXSS UST Area.....	27

INTERIM PILOT TEST RESULTS AND EXPANDED PILOT TEST DESIGN

An initial bioventing pilot test was completed at the Base Exchange Service Station Underground Storage Tank (BXSS UST) area on Vandenberg Air Force Base, California during the period of 10 to 17 September 1992. The purpose of Part II is to describe the results of the initial pilot test at the site and to make specific recommendations for extended testing to determine the long-term impact of bioventing on site contaminants. Descriptions of the history, geology, and contamination at the BXSS UST area are contained in Part I, the Test Work Plan.

1.0 BASE EXCHANGE UST AREA

1.1 Pilot Test Design

Installation of vapor monitoring points (MPs) and a background monitoring point (BG) in and around the BXSS UST area began on 10 September 1992, and was completed on 11 September 1992. Drilling, installation and soil sampling were directed by Mr. Larry Dudus, the Engineering-Science, Inc. (ES) site manager. The following sections describe the final design and installation of the bioventing pilot test system on this site.

Four MPs were installed at the site. A blower unit was temporarily installed on the existing groundwater monitoring well BXS-MW-12 which was used as the vent well (VW). Figures 1.1, 1.2, and 1.3 depict the actual locations and vertical profiles of the VW and MPs completed at the site. A BG for this site was constructed approximately 145 feet southeast of the site.

Soils on this site were fine to medium sand from the surface to groundwater with minor clay layers of less than 1 inch at a depth of approximately 2.5 and 5.7 feet. Groundwater occurred at a depth of 8.7 feet in the VW.

1.1.1 Air-Injection Vent Well

The existing groundwater monitoring well BXS-MW-12 was used as the air injection VW. Figure 1.4 shows construction detail for the VW. The screened interval penetrates approximately 14 feet into the groundwater. Approximately 4 feet of screen extends above the water table into contaminated soil. The VW was constructed using 4-inch-diameter, Schedule 40 PVC casing with 18 feet of screen installed from 4.7 to 22.7 feet below ground surface. The annular space between the well casing and borehole was filled with No. 16 silica sand from the bottom of the

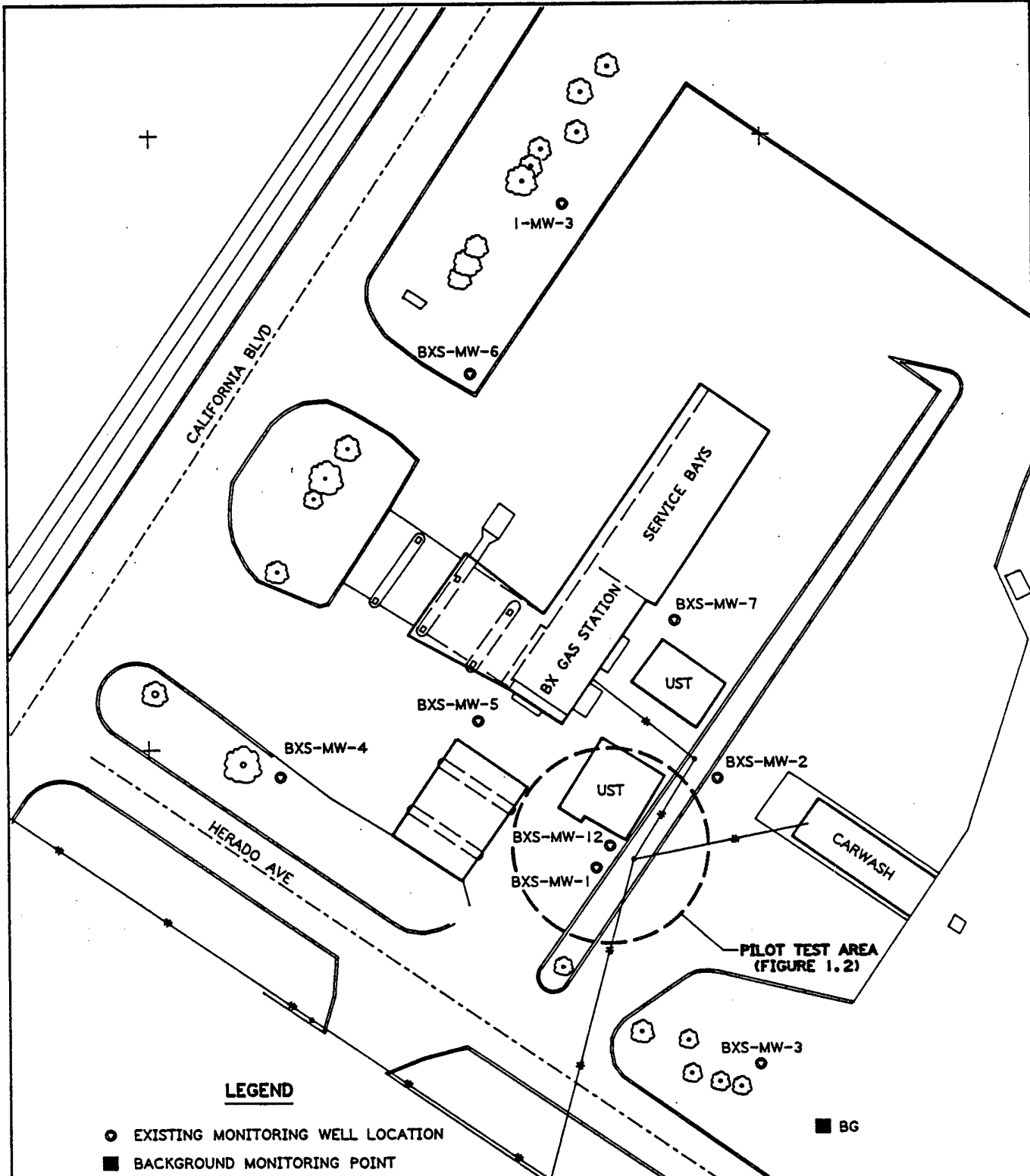

LEGEND

- EXISTING MONITORING WELL LOCATION
- BACKGROUND MONITORING POINT

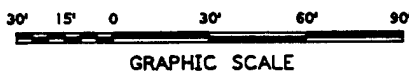

FIGURE 1.1

**SITE LOCATION
BXSS UST AREA**

VANDENBERG AFB CALIFORNIA

ENGINEERING-SCIENCE, INC.
Pasadena, California



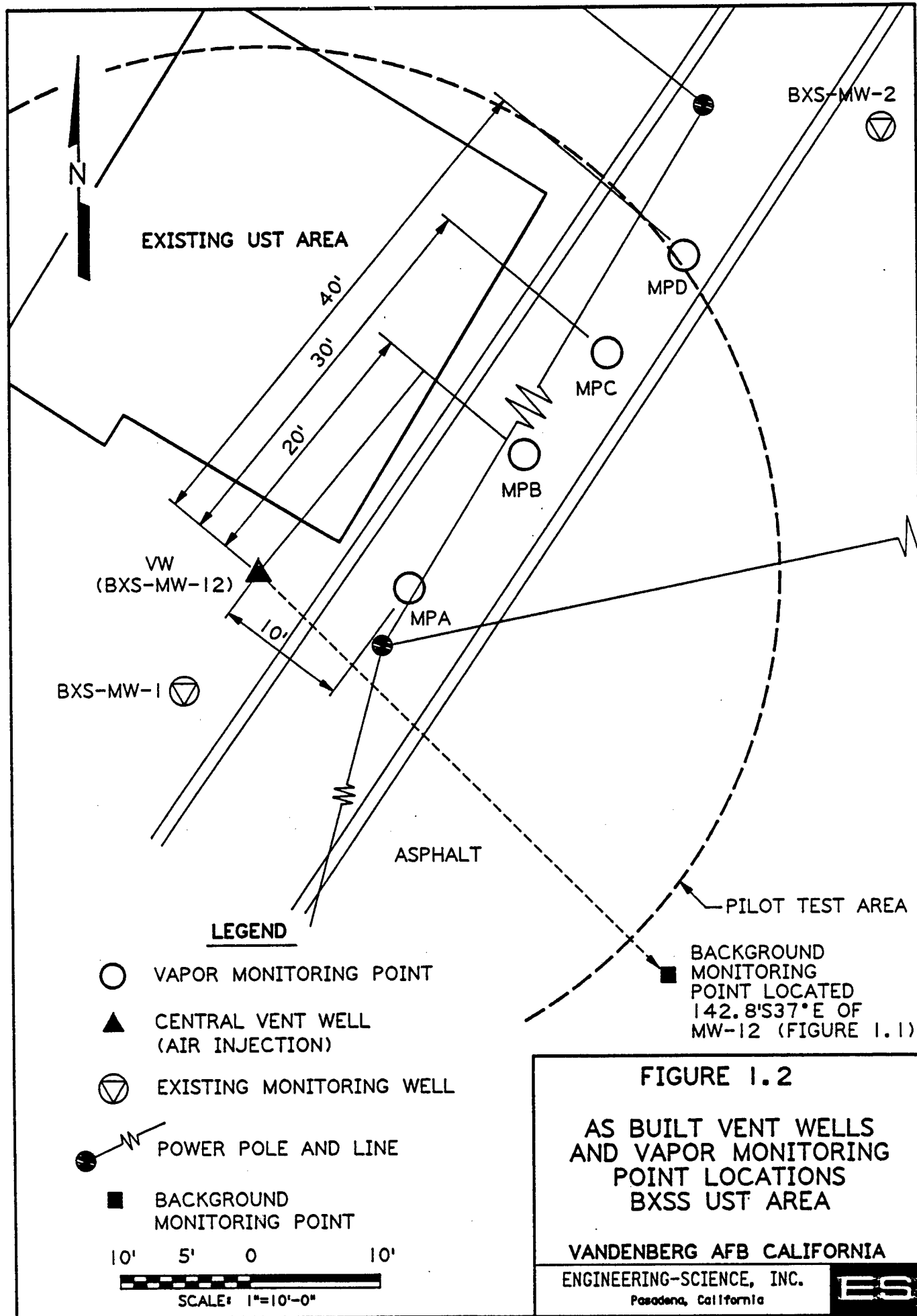

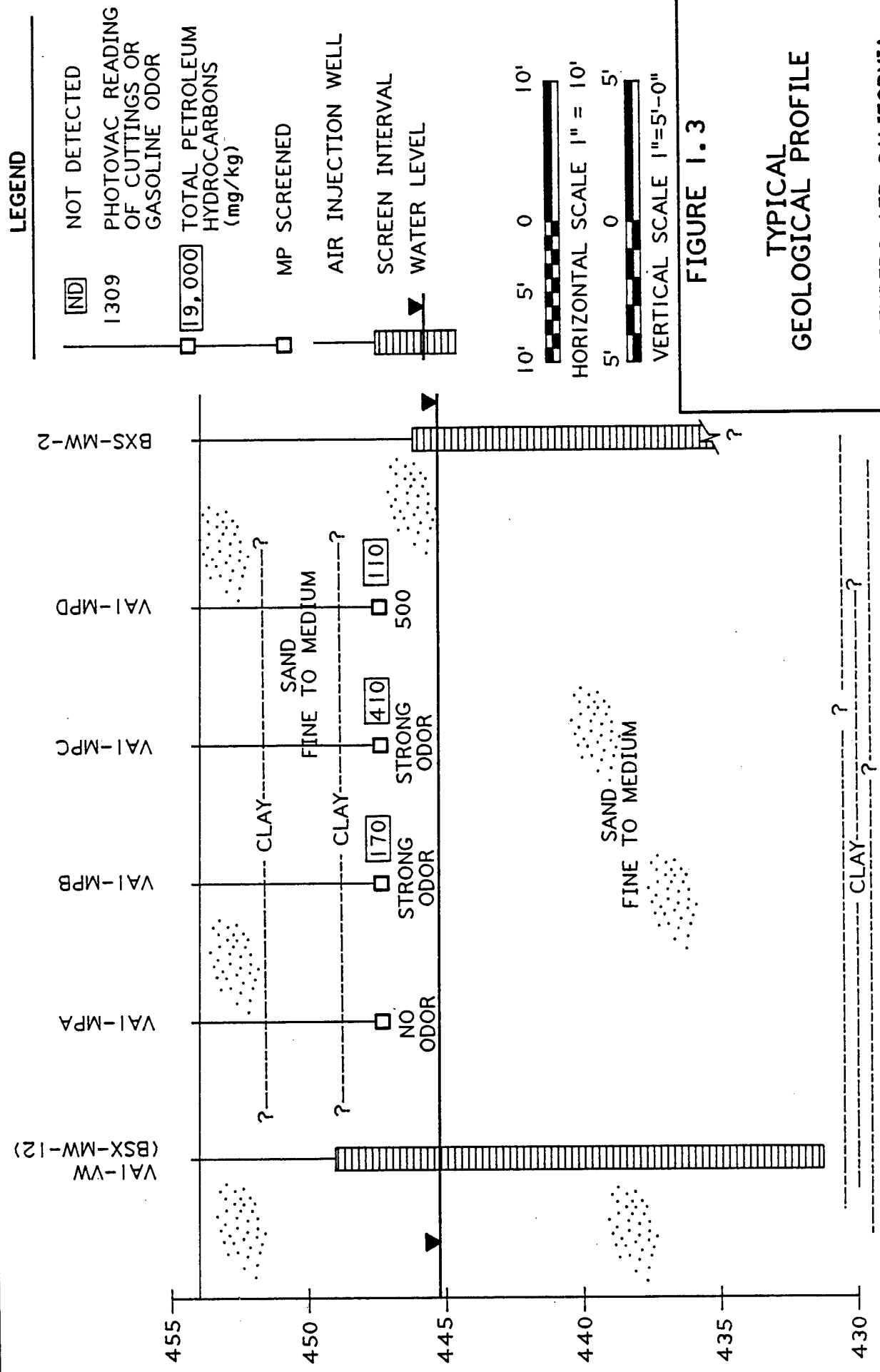

NOTE: PHOTOVAC READINGS INCOMPLETE DUE TO BATTERY FAILURE.

2" DIA SCH 40 PVC
HEADER SLOPED
TO WELL

← FROM BLOWER

CONCRETE COLLAR

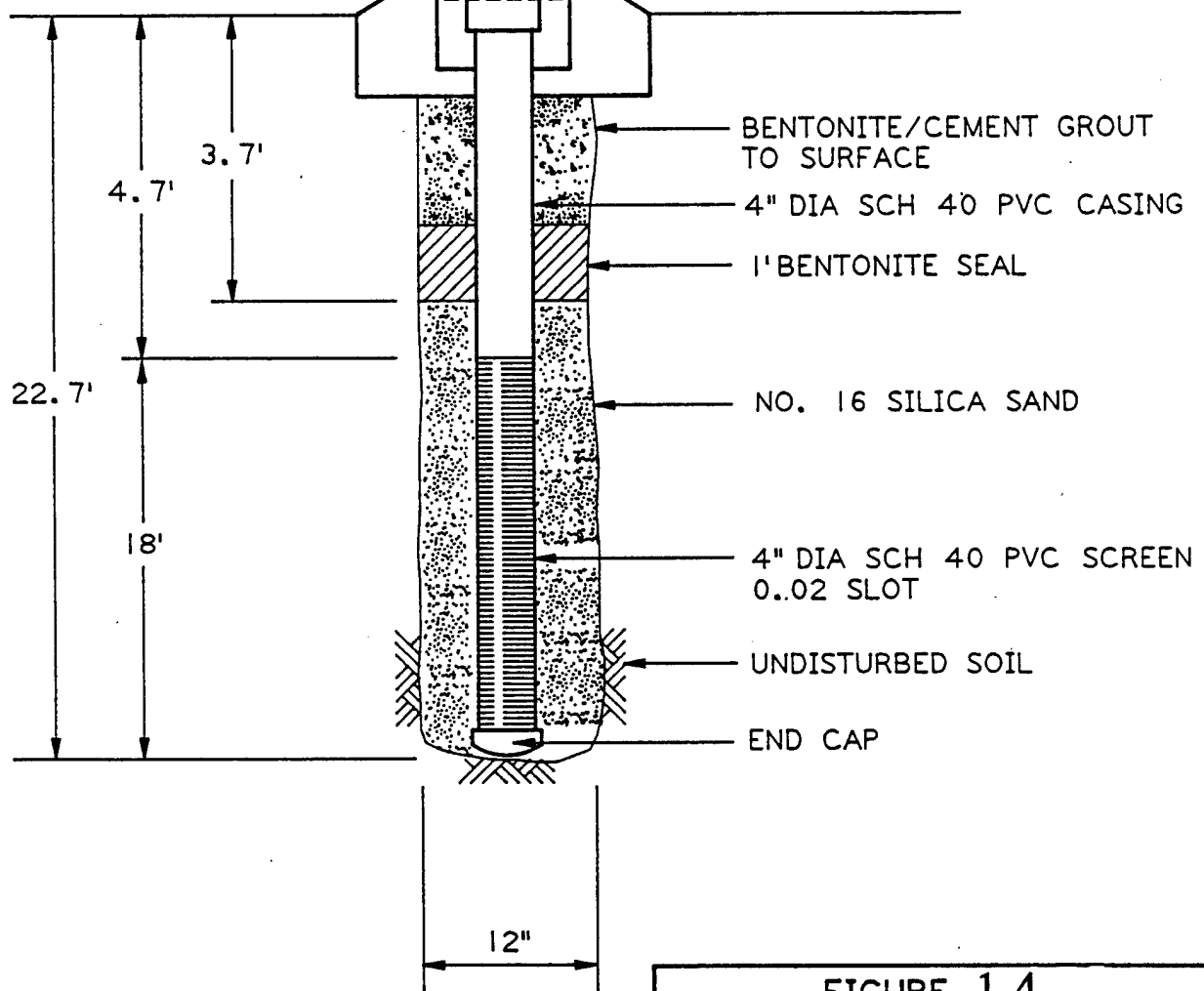

BENTONITE/CEMENT GROUT
TO SURFACE

4" DIA SCH 40 PVC CASING

1' BENTONITE SEAL

NO. 16 SILICA SAND

4" DIA SCH 40 PVC SCREEN
0.02 SLOT

UNDISTURBED SOIL

END CAP

FIGURE 1.4

INJECTION/VENT WELL
(BXS-MW-12)
CONSTRUCTION DETAIL
BXSS UST AREA

VANDENBERG AFB CALIFORNIA
ENGINEERING-SCIENCE, INC.
Pasadena, California



borehole to approximately one foot above the well screen. Bentonite pellets were placed 1.0 feet above the sand, followed by 2.7 feet of bentonite cement slurry. The top of the well was completed with a 4-inch-diameter locking cap and an 8-inch flush mount box. To connect the blower to the wellhead during the pilot test, the VW was fitted with a 4-inch to 2-inch Fernco® couple inside the flush mount box.

1.1.2 Monitoring Points

Monitoring points were installed in suspected contaminated soils. The MP screens were installed approximately 6.5 feet below ground surface. The four MPs and one BG at this site were constructed as shown in Figure 1.5. Each point was constructed using a 6-inch section of 1/2-inch PVC well screen and a 1/2-inch PVC riser pipe extending to the surface. At the top of each riser, a ball valve and 1/4-inch hose barb were installed. The top of each MP was completed with a 12-inch flush-mounted, metal well protector set in a concrete base. A thermocouple was installed at 6.5 feet in MPB to measure soil temperature. Each MP was labeled as shown in Figures 1.1 and 1.2.

1.1.3 Blower Unit

A portable 1-horsepower regenerative blower unit was used at the site for the initial pilot test. Figure 1.6 shows a schematic diagram of the blower system used. Instead of the standard extended pilot test, Vandenberg AFB has requested an expanded pilot test where the gasoline contaminated soil beneath the entire base exchange service station will be treated for 1 year. A description of the blower for the expanded system is included in Section 2.

1.2 Soil and Soil Gas Sampling Results

Hydrocarbon contamination in the MPs was generally observed from 6 feet below ground surface to the MP's total depth of 7.2 feet. It appears that contamination migrated vertically to the water table, then laterally due to groundwater movement. Some smearing of the vadose zone has occurred due to water level fluctuations. Contamination was identified based on visual appearance, odor, and volatile organic compound (VOC) field screening results. Some heavily contaminated soils were stained dark gray in color and had a strong gasoline odor. Soil samples were screened for VOCs using a photoionization detector (PID) to determine the presence of contamination. PID battery failure prevented all samples from being screened. PID readings and sample odor were used to select soil samples for laboratory analysis.

Three soil samples were collected during the installation of the MPs. Sampling procedures followed those outlined in the protocol document. According to the AFCEE protocol, one sample was collected from the interval of highest apparent contamination in VA1-MPB, VA1-MPC and VA1-MPD. Soil samples were analyzed for the following;

Analytical Parameter	Method
Total recoverable petroleum hydrocarbons (TRPH)	E 418.1
Benzene, toluene, ethyl benzene, xylenes (BTEX)	SW8020

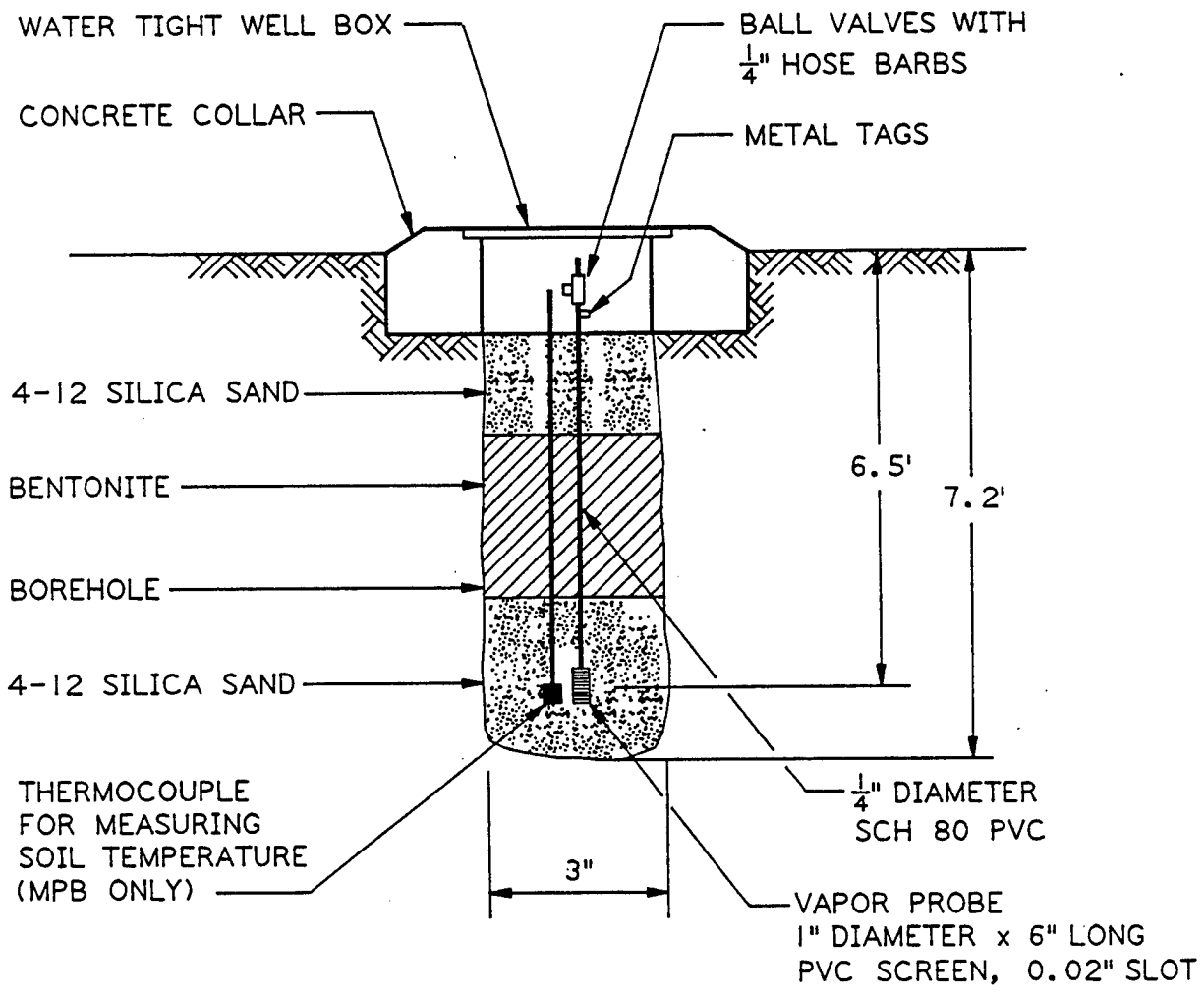
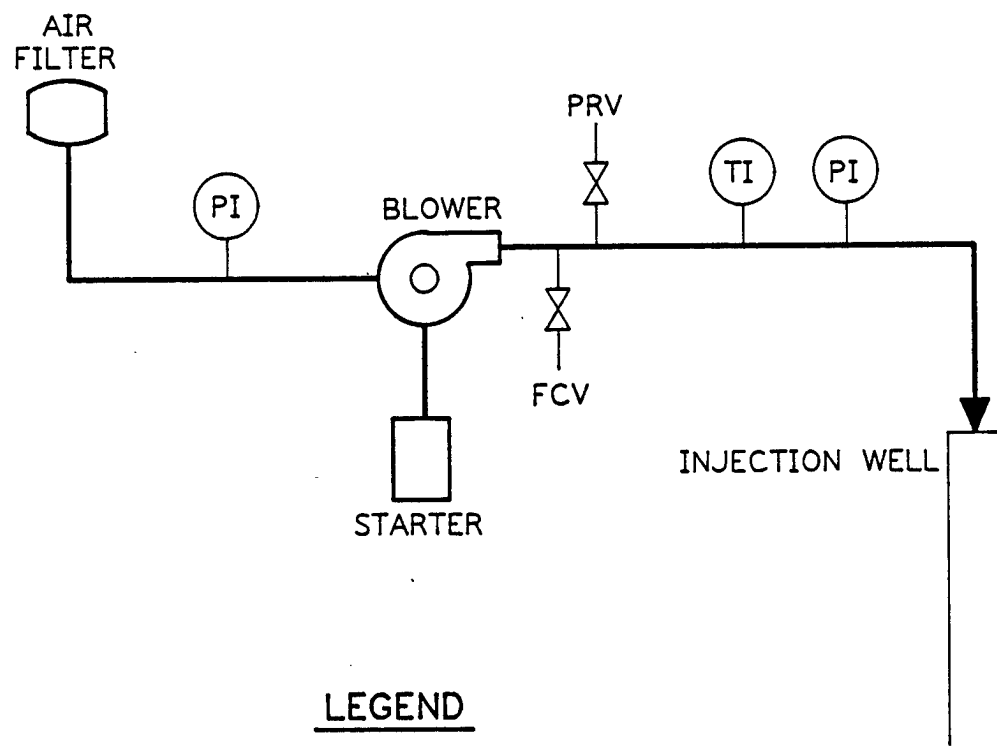

FIGURE 1.5

MONITORING POINT
CONSTRUCTION DETAIL
BXSS UST AREA

VANDENBERG AFB CALIFORNIA
ENGINEERING-SCIENCE, INC.
Denver, Colorado





LEGEND

- (PI) PRESSURE INDICATOR (INCHES OF H₂O)
- (TI) TEMPERATURE INDICATOR (FAHRENHEIT)
- FCV MANUAL FLOW CONTROL VALVE
- PRV AUTOMATIC PRESSURE RELIEF VALVE

FIGURE 1.6
BLOWER SYSTEM
INSTRUMENTATION DIAGRAM
FOR AIR INJECTION
BXSS UST AREA
VANDERBERG AFB CALIFORNIA
ENGINEERING-SCIENCE, INC.
 Pasadena, California



Soil moisture	ASTM D2216
pH	SW9045
Particle size	UCM
Alkalinity	A403
Total iron	SW7380
Total Kjeldahl nitrogen	E351.2
Total phosphorus	E365.3

Samples for TRPH and BTEX analysis were collected using an AMS® soil core sampler containing brass tube liners. Soil samples collected in the brass tubes for TRPH and BTEX analyses were immediately trimmed and the ends sealed with Teflon sheets held in place by plastic caps. Soil samples collected for physical parameter analyses were placed into glass sample jars as specified in the bioventing field sampling plan.

Despite high PID readings and gasoline odor in MPB, MPC and MPD, only MPD had O₂ readings at or below 2 percent. *In situ* respiration tests must be conducted in anaerobic, or near anaerobic soils (O₂ < 2%). Soil gas was also sampled at monitoring wells BXS-MW-5 and BXS-MW-7. Because these wells had zero oxygen readings they could be used for the respiration test. Soil gas samples were collected using SUMMA® canisters from the VW (BXS-MW-12), VA1-MPD, and BSX-MW-7, the three wells used for respiration testing. Before sampling, the wells and MPs were completely purged as described in the protocol document.

Soil samples were shipped via Federal Express® to the ES Berkeley laboratory for chemical and physical analysis. Soil gas samples were shipped via Federal Express® to Air Toxics, Inc. in Rancho Cordova, California for total volatile hydrocarbon (TVH) and benzene, toluene, ethyl benzene, and xylenes (BTEX) analysis. The results of these analyses are provided in Table 1.1. Soil analysis for BTEX compounds indicated that little benzene remains in this gasoline residual. The detection limit for benzene was 5 µg/kg. Given the warm soil conditions and the age of this spill, it is not surprising that the remaining benzene on this site is found primarily in the soil vapor phase and not adsorbed to the soil.

1.3 Exceptions to Test Protocol

The following exceptions to the protocol document occurred at the site.

- Due to a miscommunication with the lab, soil gas samples were analyzed for TRPH as jet fuel instead of gasoline.
- Soil gas samples were collected from the VW, BXS-MW-7, and VA1-MPD instead of the VW, VA1-MPA, and VA1-MPD.

1.4 Test Results

1.4.1 Initial Soil Gas Chemistry

Prior to initiating any air injection at BXS UST area, all MPs, the BG, BXS-MW-5, and BXS-MW-7 were purged, and initial oxygen, carbon dioxide, and TVH concentrations were sampled using portable gas analyzers, as described in the

Table 1.1
Base Exchange Service Station UST Area
Soil And Soil Gas Analytical Results

Analytical Method	Analyte (Units) ^{a/}	Sample Location-Depth (feet below ground surface)				
		VA1-MPB-6 feet	VA1-MPC-6 feet	VA1-MPD- 5 feet 8 inches	BXS-MW7	VA1-VW (BXS-MW-12)
Soil Hydrocarbons						
E418.1	TRPH (mg/kg)	170	410	110		NA ^{b/}
SW8020	Benzene (µg/kg)	ND ^{c/}	ND	ND		NA
	Toluene (µg/kg)	1800	4900	9500		NA
	Ethyl benzene (µg/kg)	2700	5700	6200	NA	
	Xylenes (µg/kg)	22000	69000	46000		NA
Soil Gas Hydrocarbons						
TO-3	TVH (ppmv)			11,000	45,000	2,400
	Benzene (ppmv)			68	400	12
	Toluene (ppmv)			190	61	2.4
	Ethyl benzene (ppmv)			21	60	3.6
	Xylenes (ppmv)			160	240	18
Soil Inorganics						
SW 7380	Iron (mg/kg)	3000	3320	2430		NA
A 403	Alkalinity (mg/kg as CaCO ₃)	ND	ND	60		NA
SW 9045	pH (units)	6.5	6.7	7.5		NA
E351.2	TKN (mg/kg)	59	70	180		NA
E365.3	Phosphates (mg/kg)	95	120	90		NA
Soil Physical Parameters						
ASTM D2216	Moisture (% wt.)	7.2	7.7	5.0		NA
UCM	Gravel (%)	0	0	0		NA
	Sand (%)	63	70	66		NA
	Silt (%)	27	20	20		NA
	Clay (%)	10	10	14		NA

a/ TRPH - total recoverable petroleum hydrocarbons; mg/kg = milligrams per kilogram, ppmv = parts per million, volume per volume;

µg/kg = micrograms per kilogram, TVH = total volatile hydrocarbons;

CaCO₃ = calcium carbonate; TKN = total Kjeldahl nitrogen.

b/ NA = Not Analyzed

c/ ND = not detected.

protocol document (Hinchee et al., 1992). Table 1.2 summarizes the initial soil gas chemistry on this site. These data also demonstrate the relationship between depleted oxygen levels and more contaminated soils. In highly contaminated soils, microorganisms have completely depleted soil gas oxygen supplies. Because BXS-MW-5 and BXS-MW-7 are also located in an asphalt covered area, oxygen diffusion from the atmosphere cannot occur, resulting in zero oxygen levels. In contrast, the background monitoring point (VA1-BG) has near atmospheric levels of oxygen at a depth of 6 feet since little or no oxygen depletion is occurring due to abiotic reactions or non-fuel hydrocarbon degradation. Natural organic and abiotic oxygen uptake should also be absent in the pilot test area.

Table 1.2
Base Exchange UST Area
Initial Soil Gas Chemistry

Location	O ₂ %	CO ₂ %	TVH ppmv	Temp °F
BXS-MW-12	11.0	9.4	870	NA
VA1-MPA	11.6	8.5	210	NA
VA1-MPB	8.2	10.5	3,000	74.7
VA1-MPC	6.0	11.6	1,500	NA
VA1-MPD	1.0	15.0	1,900	NA
BXS-MW-5	0.0	16.0	9,000	NA
BXS-MW-7	0.0	17.0	>10,000	NA
VA1-BG	20.4	1.2	200	NA

1.4.2 Soil Gas Permeability

A soil gas permeability test was conducted according to protocol procedures. Air was injected into BXS-MW-12 at a rate of approximately 55 standard cubic feet per minute (scfm) and a well head pressure of 35 inches of water. The maximum pressure response at each MP is listed in Table 1.3. Pressure influence was not observed beyond 10 feet (MPA) during the initial two hour test. The UST backfill apparently short-circuited a portion of the injected air flow. Due to the rapid response and relatively short time to achieve steady-state conditions (approximately 2 minutes), the steady-state method of determining soil gas permeability was selected. As discussed in the protocol, the dynamic method of determining soil gas permeability that is coded in the Hyperventilate® model is not appropriate for soils

which reach steady-state in less than 10 minutes. Using the steady-state method, soil gas permeability was estimated to be a minimum of 5.9 darcys, which is typical for sandy soils.

Table 1.3
Base Exchange UST Area
Steady-State Pressure Response
Air Permeability Test

Monitoring Point	BXS-MW-1	VA1-MPA	VA1-MPB	VA1-MPC	VA1-MPD
Distance From VW in Feet	10.65	9.9	20.1	30.1	40
Time (min)	1	2	130	130	130
Max Press (in inches H ₂ O)	0.9	0.9	0.0	0.0	0.0

1.4.3 Oxygen Influence

The depth and radius of oxygen increase in the subsurface resulting from air injection in the central VW is the primary design parameter for bioventing systems. Optimization of full-scale and multiple VW systems requires pilot testing to determine the volume of soil which can be oxygenated at a given flow rate and VW screen configuration.

Table 1.4 describes the change in soil gas oxygen levels that occurred during a 17-hour air-injection test. After 6 hours of injecting at 55 scfm into BXS-MW-12, an odor of degraded gasoline was noted around the UST vault lids. A slight positive pressure at UST manhole covers was also observed. To reduce the risk of migration of vapor towards the service station and air emissions, the flow rate to the well was reduced to less than 25 scfm by opening the pressure-relief valve. The blower injected air at this reduced rate for 11 more hours.

Despite short-circuiting caused by the UST backfill material and the flow reduction, an increase in O₂ was observed in VA1-MPD, 40 feet from the VW. Based on bioventing systems operating under similar soil conditions at Eglin AFB, FL, and Charleston, SC it is anticipated that the steady-state radius of oxygen influence for a long-term bioventing system could exceed 40 feet at flow rates as low as 10 scfm per well. The soils at the Eglin AFB site are also sandy and the contaminated area is also covered with asphalt. Future monitoring at this site during the extended test will better define the treatment radius and optimum flow rates.

Table 1.4
Influence of Air Injection at Vent Well
on Monitoring Point Oxygen Levels

Monitoring Point	Distance from VW (ft)	Depth (ft)	Initial O ₂ (%)	Final O ₂ (%)
VA1-MPA	9.9	6	11.6	20.0
VA1-MPB	20.1	6	8.2	12.0
VA1-MPC	30.1	6	6.0	10.0
VA1-MPD	40	6	1.0	2.0

1.4.4 In Situ Respiration Rates

In situ respiration tests are performed by injecting air (oxygen) into several contaminated MPs and then measuring the biological oxygen uptake over time. As described earlier, existing wells BXS-MW-5 and BXS-MW-7 were used during the *in situ* respiration test due to high initial O₂ readings in VA1-MPA, VA1-MPB and VA1-MPC. It appears that the soils under this grassy area are receiving adequate oxygen through natural diffusion and do not require forced aeration. The results of *in situ* respiration testing at this site are presented in Figures 1.7-1.9. The oxygen loss at monitoring points VA1-MPD, BXS-MW-5, and BXS-MW-7 ranged from 0.003 to 0.005 percent per minute during the initial 4000 minutes of testing.

A helium in air mixture was injected into VA1-MPD. Since helium is a conservative, inert gas, the change in helium concentrations over time can be useful in determining if oxygen diffusion is responsible for a portion of the oxygen lost from each MP. Figure 1.10 compares oxygen utilization and helium retention for monitoring point VA1-MPD. Approximately 87 percent of the helium was lost from the soil test volume during the same 4000 minutes of testing. This estimate is based upon an average injection helium concentration of 2.5 percent. Because helium is approximately 2.8 times more diffusive than oxygen, the estimated fractional loss of oxygen due to diffusion in those soils is approximately 30 percent. Thus, the loss of oxygen due to biodegradation is approximately 30 percent less than the measured rate of .003 to .005 percent per minute. The corrected oxygen utilization rate has been conservatively estimated at .002 to .0035 percent.

Based on oxygen utilization rates observed during the initial 4,000 minutes of respiration testing, an estimated 580 to 990 milligrams (mg) of fuel per kilogram (kg) of soil can be degraded each year on this site. This estimate is based on an average air-filled porosity of 0.15 liters per kilogram of soil, and a conservative ratio of 3.5 mg of oxygen consumed for every 1 mg of fuel biodegraded. A more detailed explanation of these calculations is provided in the protocol document.

Figure 1.7
 Respiration Test
 Monitoring Point VA1-MPD
 Vandenberg AFB, CA

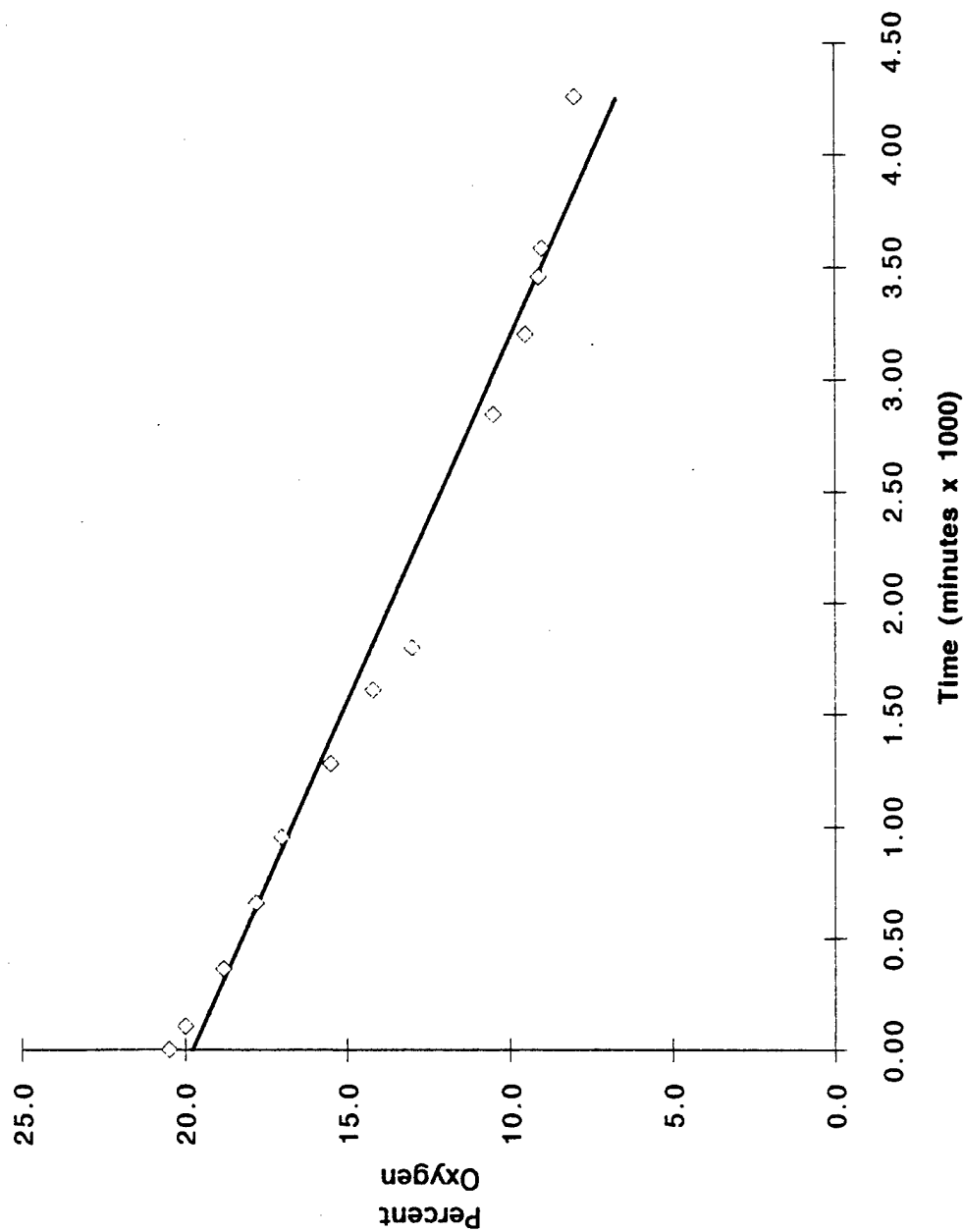

Figure 1.8
Respiration Test
Monitoring Point BXS-MW-7
Vandenberg AFB, CA

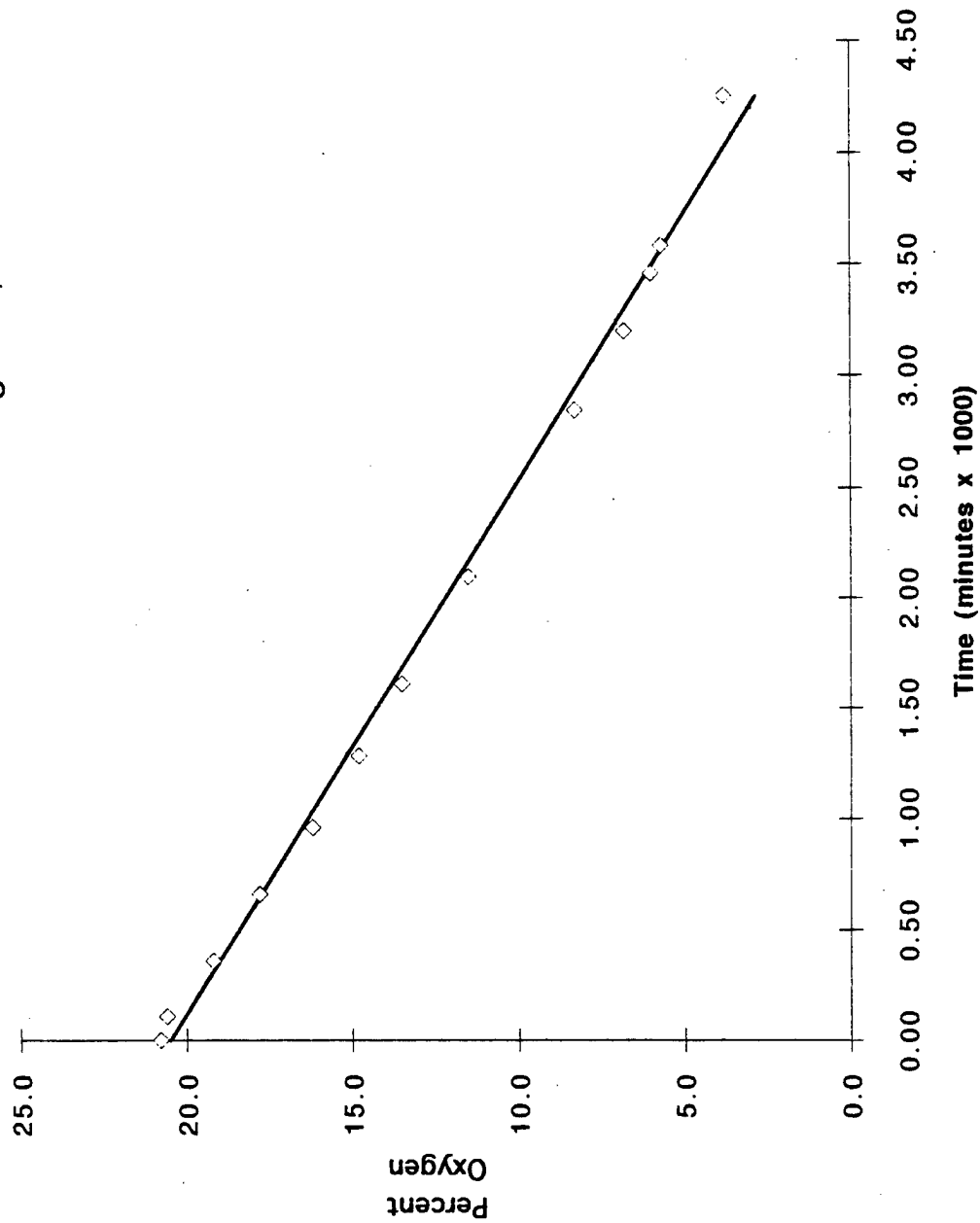
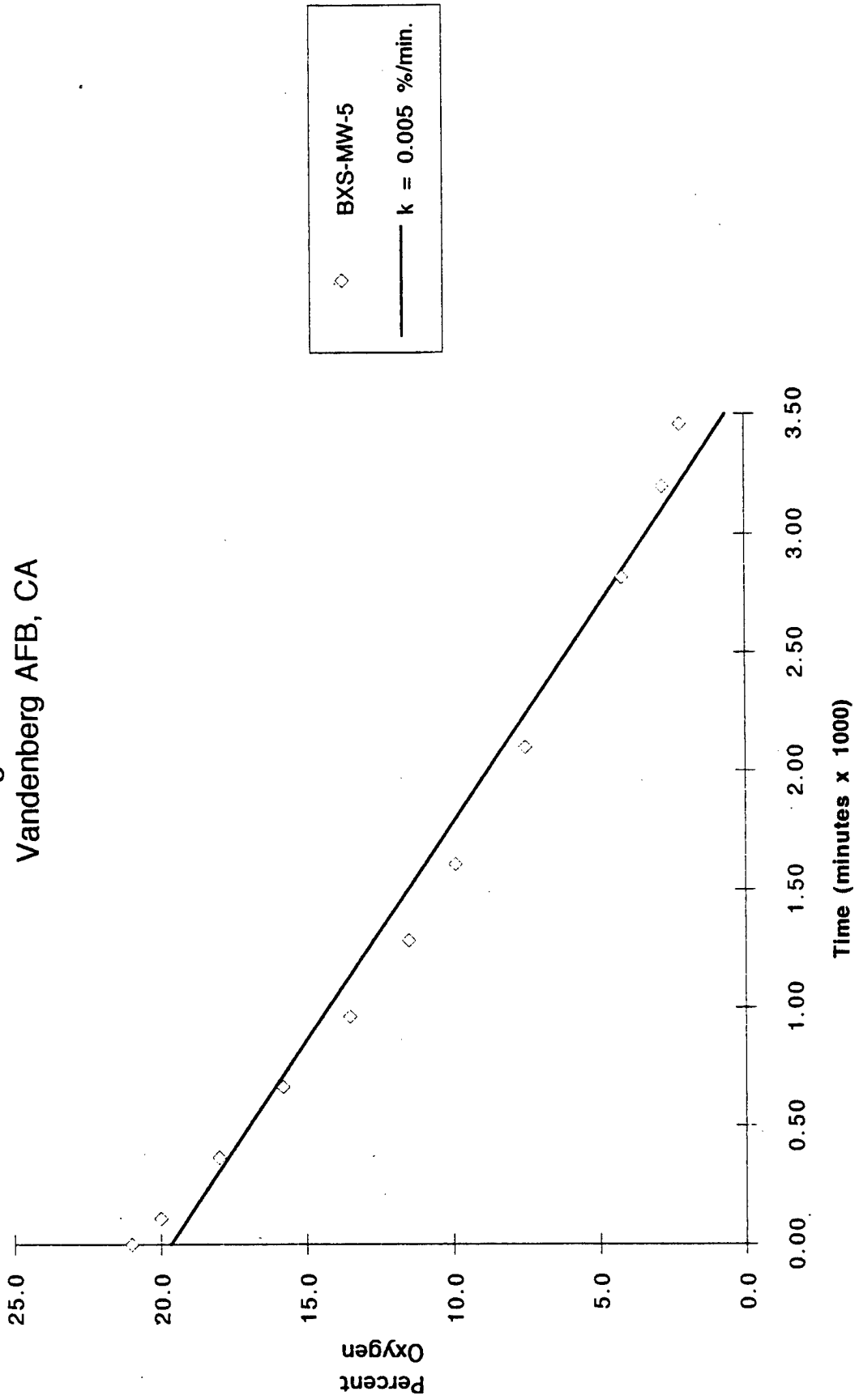
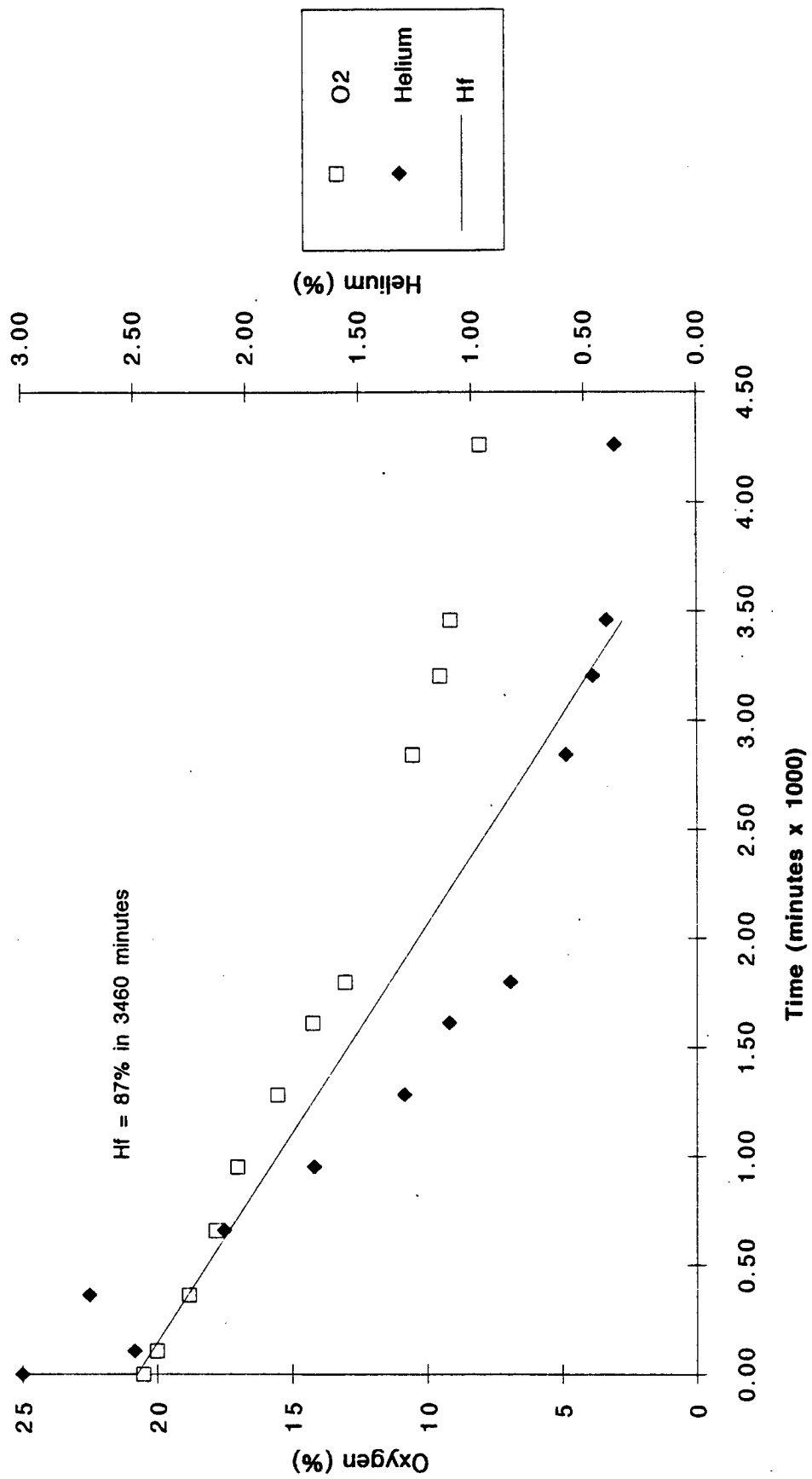

Figure 1.9
 Respiration Test
 Monitoring Point BXS-MW-5
 Vandenberg AFB, CA



*24
 63
 1440 min/day*

Figure 1.10
 Respiration Test
 Oxygen and Helium Concentrations
 Monitoring Point VA1-MPD
 Vandenberg AFB, CA



1.4.5 Potential Air Emissions

As demonstrated during the 17 hour air injection period, the potential for air emissions at the site is high if air is injected into highly contaminated soil during the initial months of bioventing operations. Some short-circuiting of injected air occurred in the UST backfill material causing a gasoline odor over the top of the UST manholes. Initial testing clearly demonstrated that air injection in highly contaminated soils would result in gasoline vapor transport and potential emissions to the atmosphere. As a result, a decision was made to extract and treat volatile soil vapors rather than risk the explosive or health hazards that could be associated with air injection.

To assist in the design of a vapor treatment system for extended bioventing, a vapor sample was collected from BXS-MW-5. The 1 horsepower blower used during the injection test was repiped and used to extract vapor from BXS-MW-5. The blower operated for 1 hour at a flow rate of approximately 30 scfm (-44 inches H₂O)). At the end of the 1 hour test, a Tedlar® bag was filled with extracted vapor through a port on the blower's discharge line. The gas within the Tedlar® bag was immediately transferred to a SUMMA® canister. Results of the sampling are included in Table 1.5. The high levels of volatile organics detected in this soil gas sample confirmed the need for initially operating this bioventing system in a soil vapor extraction mode with aboveground vapor treatment.

Table 1.5
1 hour Vapor Extraction Test
Sample Analytical Results

Location	TVH As Jet Fuel (ppmv)	Benzene (ppmv)	Toluene (ppmv)	Total Xylenes (ppmv)	Ethyl benzene (ppmv)
BXS-MW-5	78,000	420	690	220	50

2.0 EXPANDED PILOT TESTING

2.1 Concept of Operations

2.1.1 Summary of Initial Testing

Initial pilot testing has demonstrated that the silty-sands on this site are permeable to air flow and that oxygen can be distributed at distances of at least 40 feet from individual vent wells. In situ respiration testing has measured fuel biodegradation rates of 1.6 to 2.5 milligrams of fuel per kilogram of soil per day when oxygen is provided to the contaminated soils at this site. Analysis of soil gas indicates that total volatile hydrocarbon concentrations of 11,000 - 78,000 ppmv exist beneath the asphalt areas of the site. No free product has been measured on the site and these volatiles are expected to decrease rapidly once the initial pore volume of soil gas is removed from the soil.

2.1.2 Phase One Soil Venting Operations

The first phase of the expanded pilot test will focus on removing the initial high levels of volatile hydrocarbons from the soil and dewatering the site to increase the amount of soil which can be contacted by the bioventing process. Figure 2.1 illustrates Phase One operations. Dewatering wells will be screened from a depth of approximately 5 feet to 20 feet below ground surface. Each well will be equipped with a pneumatic ejection pump and will be sealed at the top and connected to a air vacuum line so that soil gas can be extracted from the exposed vadose zone around each well. The collection and treatment of extracted groundwater is described in separate documents produced by the Bureau of Reclamation.

Extracted soil gas will pass through a PADRE® vapor treatment system where the initial high volatiles will be adsorbed and condensed to liquid fuel. The treated soil gas from the PURUS system will be recirculated through the soil using air injection, "biofilter" trenches located along the perimeter of the gasoline spill site. The PADRE® system will be operated so that no more than 1000 ppmv total hydrocarbons are ever returned to the soil. Based on the fuel biodegradation rates of 1.6 to 2.5 milligrams of fuel per kilogram of soil per day measured during initial testing, approximately 52,000 cubic feet of soil will be required to biodegrade the maximum loading of 1000 ppmv assuming a flow rate of 40 scfm. Additional details on the PADRE® system, the design of the bioventing system, and air emission monitoring are provided in Section 2.2, 2.3 and Appendixes A and B.

The total duration of Phase One is expected to be 60 to 90 days. Once extracted soil gas volatiles have decreased to less than 1000 ppmv, Phase Two bioventing operations will begin.

2.1.3 Phase Two Bioventing Operations

Phase Two bioventing operations will focus on the in situ biodegradation of the remaining fuel residuals in the soil. Dewatering will continue to enhance soil bioremediation by exposing the entire contaminated soil profile to oxygen rich air. Figure 2.2 illustrates Phase Two operations. Based on initial pilot testing results and the experience of ES at other sites, a soil gas extraction rate of approximately 40 scfm should be sufficient to provide oxygen to the 60,000 to 80,000 cubic feet of contaminated soil beneath the BX Service Station. This equates to approximately 10 soil gas exchanges per day through the contaminated volume. Clean soil gas entering the site and recirculated soil gas will provide sufficient oxygen to sustain fuel biodegradation beneath the asphalt areas.

Once the initial high levels of volatiles (> 1000 ppmv) are removed from the soils, the PADRE® system will be taken off-line. Because the concentration of volatiles will continue to decrease in the extracted soil gas, the quantity of soil "biofilter" required to degrade these hydrocarbons will also decrease over time. A flux chamber will be used to monitor the soil surface to insure that significant volatiles emissions are not occurring over the top of recirculation trenches. Additional details on air monitoring are found in Section 2.3.

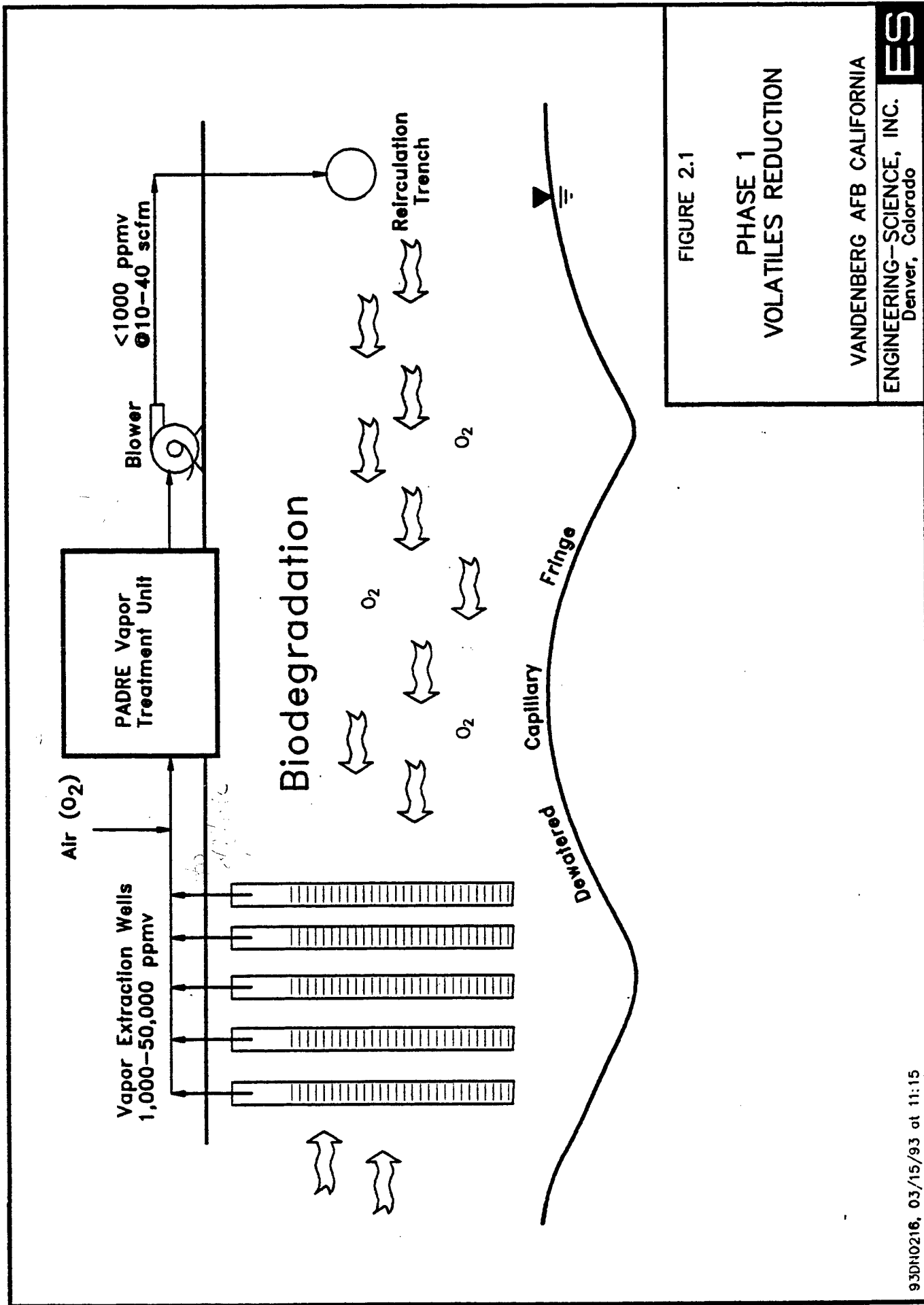

FIGURE 2.1

PHASE 1
VOLATILES REDUCTION

VANDENBERG AFB CALIFORNIA

ENGINEERING-SCIENCE, INC.
Denver, Colorado



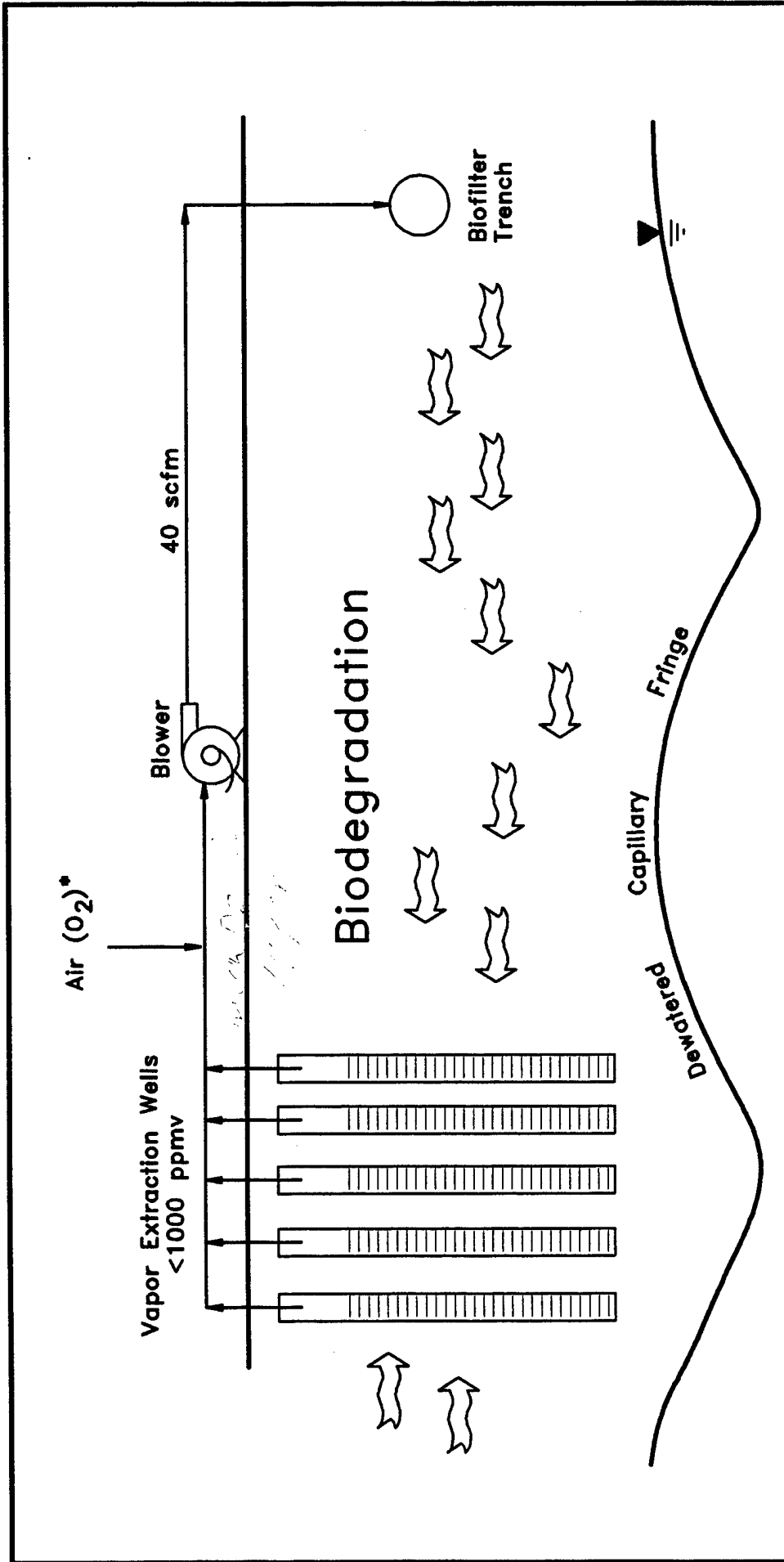

FIGURE 2.2

**PHASE 2
EXTENDED BIOVENTING**

VANDENBERG AFB CALIFORNIA
ENGINEERING-SCIENCE, INC.
Denver, Colorado



* IN ORDER TO INSURE AEROBIC CONDITIONS FOR FUEL BIODEGRADATION, A SMALL QUANTITY OF AIR (O_2) WILL BE ADDED TO THE RECYCLED SOIL VAPOR.

2.2 Overview of System Design

This section is intended to provide an overview of the key components of the bioventing system design. Additional details on the construction of this system are included in Appendix A.

2.2.1 Dewatering/Vapor Extraction Wells

This bioventing system has been integrated with a dewatering system designed by the Bureau of Reclamation. Figure 2.3 illustrates the layout of the dual purpose dewatering and vacuum extraction wells proposed for this site. Approximately 15 to 16 of these 4-inch diameter wells will be constructed. Approximately five of these wells will be used as vacuum wells at any one time. These vacuum wells will draw oxygenated air into the site from all directions stimulating aerobic biodegradation. All wells will be used for dewatering. The dewatering of this perched shallow aquifer is expected to take approximately 18 months. During the dewatering, the fuel contaminated smear zone, which extends from approximately 7 to 11 feet, will become increasingly more accessible to air flow and to bioventing. Additional details on the construction and operation of the dewatering system are found in a separate document developed by the Bureau of Reclamation. Figure 2.4 provides additional details on the design of these dual-purpose wells.

2.2.2 Soil Gas Extraction System

Because of the potential danger of uncontrolled migration of the gasoline vapor, the blower will extract rather than inject air through the contaminated soil zone. The soil gas extraction system is designed to operate at a flow rate that is sufficient to provide oxygen to the entire contaminated volume while minimizing volatile emissions at the site. Each vacuum extraction well will have a separate flow control valve and be manifolded to a common vacuum line connected to an explosion-proof blower. Based on the radius of influence measured during the initial pilot testing at this site and experience at a similar site at Eglin AFB, a blower capable of operating at 40 scfm at a vacuum of 40 inches H₂O will be installed. A 2.5 horsepower Gast Model 5110 or EG&G Rotron Model 505 explosion proof or equivalent should be adequate for this application, and provide additional capacity for recirculation of vapor-laden air. A dilution valve located on the vacuum side of the blower will be used to control flow rates and supply additional oxygen to the recirculation system.

2.2.3 PADRE® Vapor Treatment System

The PADRE® vapor treatment system is a product of the PURUS Corporation and has been designed to control VOC emissions at remediation sites and in industrial air processes. The PADRE® system purifies contaminated air by trapping the contaminant in a proprietary adsorbent filter bed and then desorbing the concentrated contaminant using a condensation process. The condensed liquid (fuel) can then be recycled or disposed of in an environmentally acceptable manner. The PADRE® Model 1.6 has been specified for this application and will be capable of removing up to 8.8 pounds per hour of volatile hydrocarbons from the extracted gas stream. Since the PADRE® system is capable of removing over 99 percent of the BTEX compounds from the extracted soil gas, it will have little difficulty

LEGEND

- EXISTING MONITORING WELL LOCATION
- △ PROPOSED DEWATERING/VENT WELLS
- Y- DEWATERING/VACUUM LINE
- AIR SUPPLY LINE
- AIR INJECTION TRENCH
- EXTENT OF SOIL CONTAMINATION

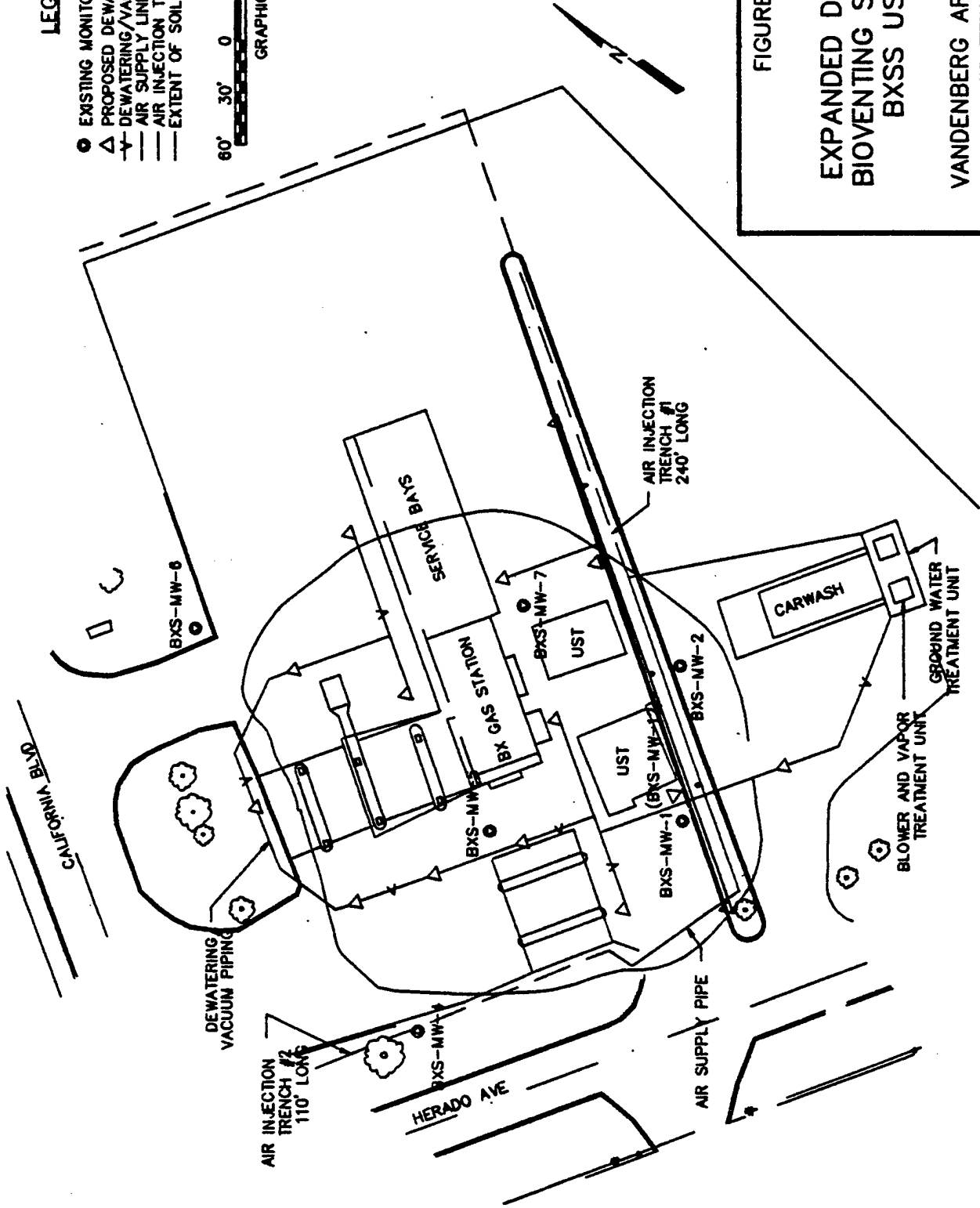

FIGURE 2.3

**EXPANDED DEWATERING/
BIOVENTING SYSTEM PLAN
BXSS UST AREA**

VANDENBERG AFB CALIFORNIA

ENGINEERING-SCIENCE, INC.
Pasadena, California



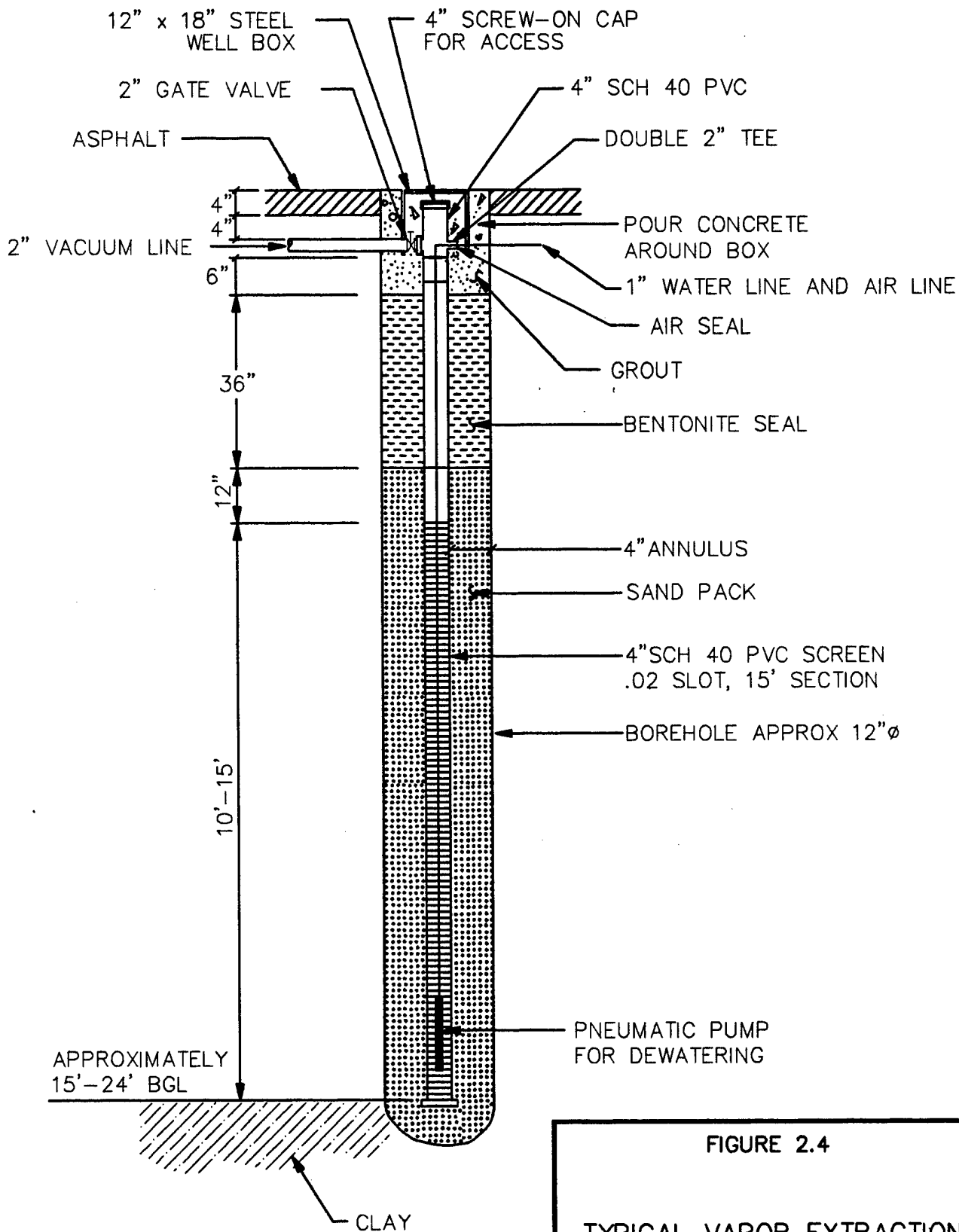

FIGURE 2.4

TYPICAL VAPOR EXTRACTION DEWATERING WELL (VEW)

VANDENBERG AFB CALIFORNIA

ENGINEERING-SCIENCE, INC.
 Denver, Colorado



insuring that recirculated soil gas does not exceed the maximum 1000 ppmv concentration for in situ biodegradation. Additional details on the design, specifications and base support of the PADRE® system are included in Appendix B.

2.2.4 Soil Gas Recirculation and Biodegradation

Previous pilot tests conducted by the US Air Force have shown that volatile fuel compounds such as BTEX can be recirculated through soils at the perimeter of a contaminated site to promote additional biodegradation of these volatiles (Miller, 1990). Soils at the perimeter of this site have already been exposed to hydrocarbon vapors and contain bacteria which are capable of biodegrading these vapors. Fuel biodegradation rates of 1.6 to 2.5 milligrams of fuel degraded per kilogram of soil per day have been measured at the Vandenberg BX Service Station site. Based on these rates of biodegradation and the approximately 52,000 cubic feet (2.7×10^6 Kg) of soil available for the reinjection biofilter at this site, a maximum hydrocarbon loading of 5.8 kilogram per day has been established. At an extraction rate of 40 scfm, this equates to a maximum concentration of approximately 3.6 mg/Liter of gas or 1000 ppmv. Figure 2.5 provides a schematic of the proposed vapor handling and treatment system including the location and typical cross-section of a recirculation trench. The recirculation trench will be divided into two branches totalling 350 feet. Based on our experience with other reinjection trenches we anticipate that injected gas will be distributed through an approximate 6 x 30 feet cross-section along the length of the trench. A layer of bentonite will be used to prevent short circuiting of injected gas to the surface and promote the desired horizontal distribution of the recirculated soil gas. The primary direction of gas flow will be toward the center of the site due to soil gas extraction gradients. A flux chamber will be used to monitor for any emissions of vapors through the ground surface. Section 2.3 provides additional details on air monitoring.

2.3 System Monitoring and Evaluation

2.3.1 Air Monitoring Plan

The goal of this bioventing research project is to minimize, and if possible, eliminate hydrocarbon emissions to the atmosphere. To achieve this goal and to document the efficiency of various components of the bioventing system, an air monitoring plan has been developed. The plan describes where, how, and when monitoring will take place and what will be monitored. During Phase One operations, soil gas entering and exiting the PADRE® unit will be analyzed for both total VOCs and for benzene. During both Phase One and Phase Two, a flux chamber will be used to monitor for surface emissions at several locations over recirculation trenches. Figure 2.6 illustrates the four primary locations where air monitoring will take place.

The flux chamber will consist of an 18-inch diameter inverted metal hemisphere which will be placed on the soil surface while air is withdrawn at a rate of one liter per minute and sampled for total VOCs(TVOCs) or benzene (BZ). TVOCs will be analyzed using a portable total hydrocarbon analyzer, GasTech Model 72-8418E. During the first week of operations, benzene will be analyzed on site using a portable gas chromatograph equipped with a flame ionization detector. Once the

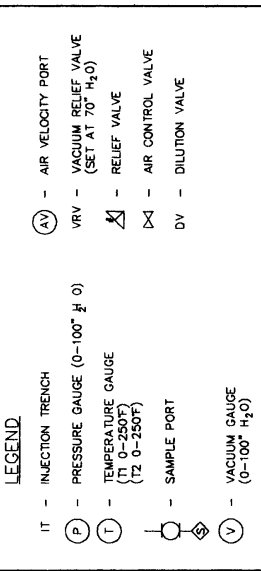

*
 BLOWER SPECS: GAST RS125-1 OR ROTRON MODEL DR505 40cfm AT 40" H₂O EXPLOSION PROOF 2.5 HP SINGLE PHASE MOTOR MAX AMPS 11.5A AT 230V
 VACUUM RELIEF VALVE SPECS: GAST AC258 1 1/2" NPT, ADJUSTABLE 30 - 170 in. H₂O, 200 cfm MAX. SILENCER FOR RELIEF VALVE, AJ121D

FLOW SCHEMATIC FOR THE BIOVENTING SYSTEM

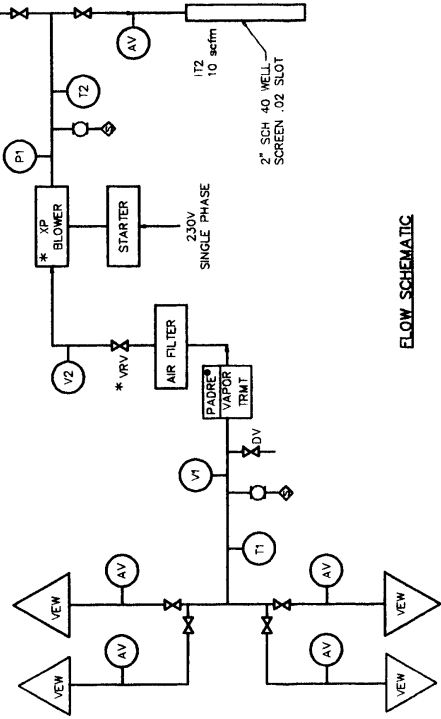

FLOW SCHEMATIC

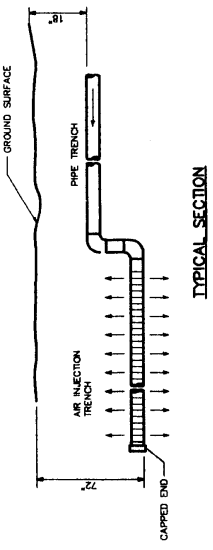

TYPICAL SECTION OF AIR INJECTION TRENCH AND PIPE TRENCH

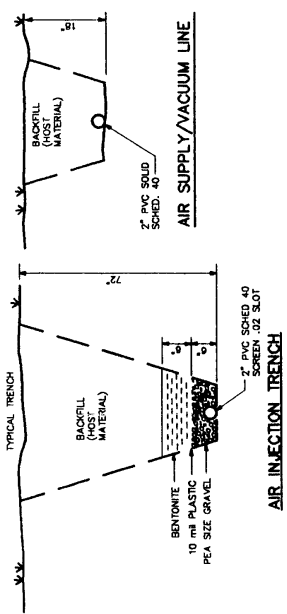

AIR INJECTION TRENCH

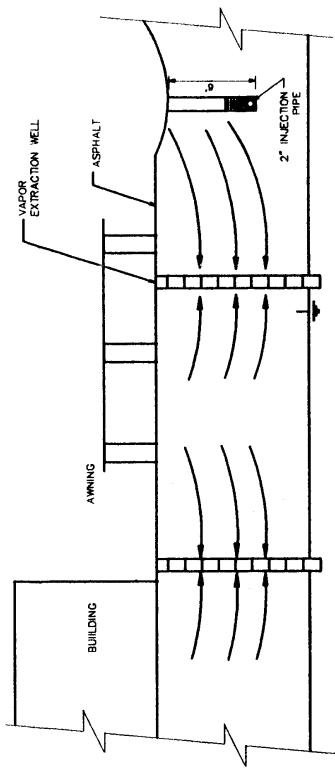

CONCEPTUAL CROSS-SECTION DESIGN FOR IN-SITU RECIRCULATION

FIGURE 2.5

**EXTENDED BIOVENTING SYSTEM
 CONCEPTUAL DETAILS**

VANDENBERG AFB CALIFORNIA
 ENGINEERING-SCIENCE, INC.
 Denver, Colorado



LEGEND

- EXISTING MONITORING WELL LOCATION
- △ PROPOSED DEWATERING/VENT WELLS
- ▽- DEWATERING/VACUUM LINE
- AIR SUPPLY LINE
- AIR INJECTION TRENCH
- EXTENT OF SOIL CONTAMINATION
- ⊙ AIR MONITORING POINT

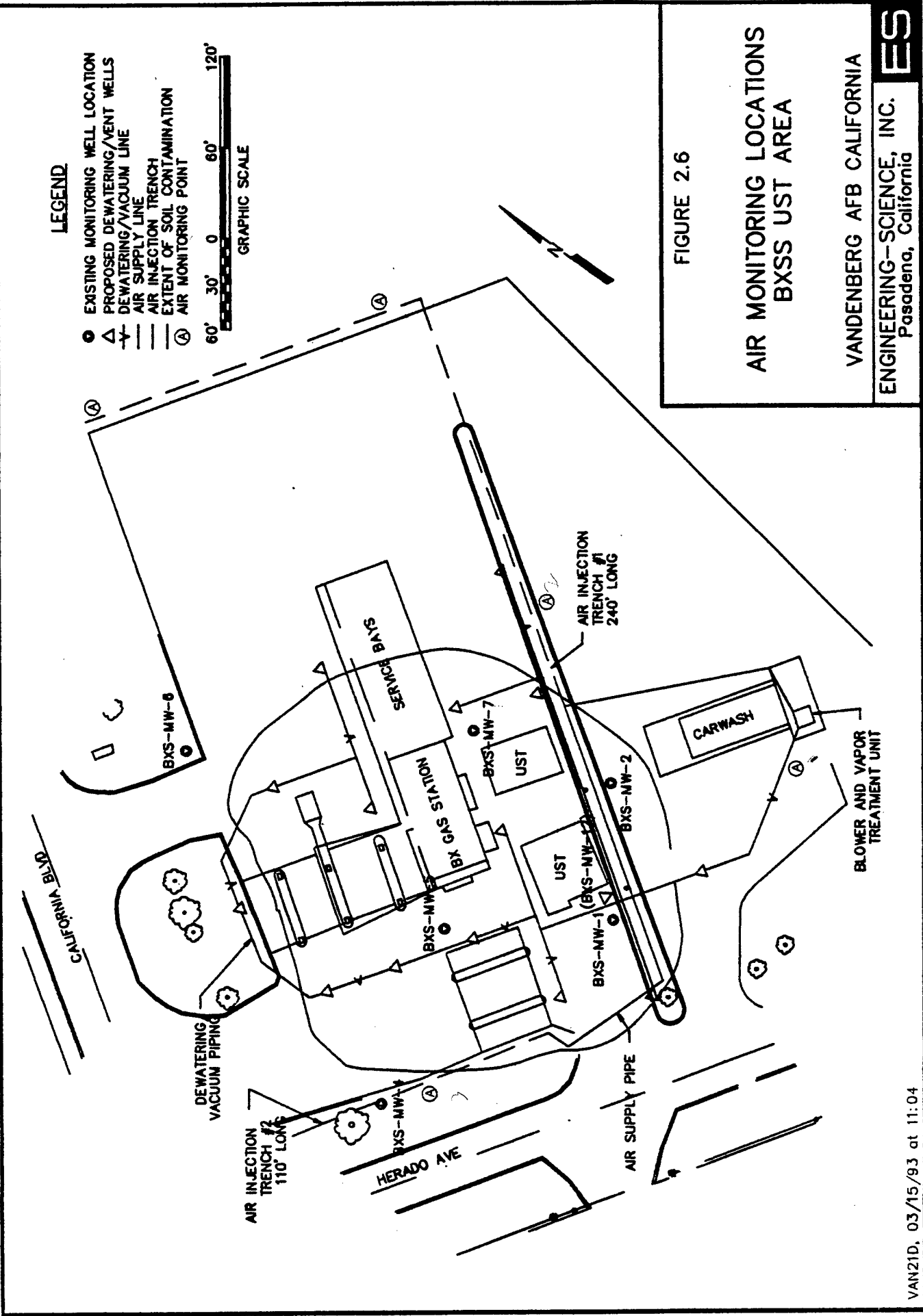

FIGURE 2.6

**AIR MONITORING LOCATIONS
BXSS UST AREA**

VANDENBERG AFB CALIFORNIA

ENGINEERING-SCIENCE, INC.
Pasadena, California



initial adjustments of the PADRE® system and bioventing system have been completed, benzene and total volatile hydrocarbons samples will be collected using SUMMA gas cannisters and shipped to Air Toxics Inc., Rancho Cordova, CA for laboratory analysis using EPA Method TO-3. Oxygen and carbon dioxide will be monitored using a Gastech Model 32520X gas analyzer.

Table 2.1 provides a summary of the frequency and type of monitoring to be conducted at each monitoring point. Air monitoring will be most intense during system startup when the highest levels of VOCs will be extracted from the soil and the performance of the PADRE® system and recirculation trenches are most critical. If atmospheric emissions of TVOCs exceed the Santa Barbara APCD standard of one pound of TVOCs per hour or if benzene is detected in flux measurements at levels exceeding the OSHA standard of 1 ppmv, the extraction rate will be reduced to improve PADRE® and biotrench efficiency.

TABLE 2.1 Sampling Frequency

Monitoring Point	Analysis	Frequency
Into PADRE® Unit	TVOCs	- Hourly 1st 12 hours - Twice Daily 1st Week - Bi-Weekly Thereafter
	Benzene	- Twice Daily 1st Week - Bi-Weekly Thereafter
	O ₂ , CO ₂	- Bi-Weekly
Out of PADRE® Unit	TVOCs	- Hourly 1st 12 hours - Twice Daily 1st Week - Bi-Weekly Thereafter
	Benzene	- Twice Daily 1st Week - Bi-Weekly Thereafter
Into Biofilter Trenches	TVOC, O ₂ , CO ₂	- Bi-Weekly (Phase One) - Monthly (Phase Two)
Flux Over Trenches	TVOCs	- Hourly 1st 12 hours - Twice Daily 1st Week - Bi-Weekly (Phase One)
	Benzene	- Twice Daily 1st Week - Once 1st Day of Phase Two Operations

2.3.2 In Situ Biodegradation Monitoring

The biodegradation of fuel residuals in the soil will be monitoring using two methods. In situ respiration tests described in Section 1.4.4 will be conducted after six months and one year of operation. This test will determine the activity of microorganisms at various points in the contaminated soil volume and how bioactivity changes as more oxygen is made available.

The second method of monitoring fuel biodegradation will measure the steady state decrease in oxygen concentrations in the soil gas passing through contaminated soil. As fresh oxygenated air passes through biologically active soil, a portion of the oxygen is consumed by fuel degrading bacteria. As this soil gas is collected by the soil vapor extraction system, and then analyzed for the average oxygen loss occurring in the soils, the oxygen deficiency can be directly related to the quantity of fuel consumed.

2.3.3 One Year Evaluation

At the end of one year of testing, three soil samples will be collected from the contaminated soil volume. Under the AFCEE pilot testing contract, ES is limited to three soil and soil gas samples which are analyzed for TRPH and BTEX. If these samples indicate that significant removal of fuel residuals has occurred, ES or the Bureau of Reclamation can take additional samples to confirm site cleanup. The number and location of these samples would be coordinated with appropriate regulatory agencies. Based on the results of the first year of bioventing, AFCEE will recommend one of two options:

1. Continue operation of the bioventing system for remediation of the site.
2. If final soil sampling indicates significant contaminant removal has occurred, AFCEE may recommend additional sampling to confirm that cleanup criteria have been achieved.

3.0 BASE SUPPORT

The following items of base support will be necessary to construct and operate the expanded bioventing pilot system. Prior to construction of the dewatering/vapor extraction wells:

- A digging permit will be required for the entire BXSS area:
- The trenching and drilling activities will have to be coordinated with the BXSS manager.
- The handling of drill cuttings and decontamination water will have to be coordinated by the Bureau of Reclamation.
- The base will be responsible for obtaining any additional regulatory permits or permissions to conduct the test.
- A work request for power support should be initiated. The basic requirement for the PADRE® unit and bioventing blower is for 230 volt, 3 phase, 150 amp service. We also request that a separate watt meter be installed on this

service so that the electrical cost of these systems can be carefully measured separate from the groundwater pumping and treatment system. A separate power pole and breaker box should be installed approximately five feet west of the car wash building. Power should be in place by 1 June 1993.

- Provide a 20-ton forklift to offload the PADRE® unit and place it on a concrete pad west of the car wash. The pad should be constructed in conjunction with the water treatment system.

During the start-up and one year operation of the bioventing system, the following base support is requested:

- During the first two to three months of operation (Phase One) the base will be responsible for collecting and recycling/disposing of the water and fuel produced by the PADRE® system. PURUS estimates that 700 gallons of fuel and water will be collected during the first two weeks of operation and 200-300 gallons per week for the next six weeks. The Bureau of Reclamation or base will provide a Baker tank for short-term storage of this condensate. The consistency of the liquid should be approximately 50 percent gasoline and 50 percent water. The base will be responsible for insuring the safe handling, transport and recycling of this recovered fuel. Water will be separated from the fuel and treated in the base industrial wastewater plant. Recovered fuel will be recycled or handled as hazardous waste in accordance with base hazardous waste storage and disposal procedures.
- Ensure that liquid nitrogen is supplied to the PADRE® unit. This will require weekly changeout of liquid nitrogen cylinders. PURUS and ES will arrange for the delivery of fresh cylinders.
- Daily system checks during Phase One operations. This will consist of approximately 30 minutes of recording pressure and flow measurements each day and transmitting this data to ES and PURUS each week.
- Weekly system checks during Phase Two Operations. This will consist of 15 minutes of pressure and flow measurements and then transmitting the data to ES once each month.

4.0 SCHEDULE

The following schedule is recommended for the extended pilot test construction and operation.

<u>Event</u>	<u>Schedule</u>
Initial Test Results Provided to AFCEE/Vandenberg AFB	11 November 1992
AFCEE/Vandenberg Review Complete	25 November 1992
Regulatory Review Meeting	18 February 1993

Final Pilot Test Design Complete	12 March 1993
Construct Pilot System	15 July - 15 Aug 1993
Begin Operations	15 August 1993
Respiration Test	February 1994
Final Respiration Test/Soil Sampling	July 1994

5.0 REFERENCES

- Site Assessment Report for Base Exchange Service Station, Site Characterization (Volume I). U.S. Bureau of Land Reclamation, March 1992.
- Field Sampling Plan for AFCEE Bioventing. Engineering-Science, Inc., 1992.
- Test Plan and Technical Protocol for a Field Treatability Test for Bioventing. Hincee, R.E., Ong, S.K., Miller, R.N., Downey, D.C., Frandt, R., January 1992.
- A Field Scale Investigation of Enhanced Petroleum Hydrocarbon Biodegradation in the Vadose Zone - Tyndall AFB, FL. Proceedings of the NWWA/API Conference on Petroleum Hydrocarbons and Organic Chemicals in Groundwater. Houston, TX. November 1990.

APPENDIX A
ADDITIONAL SPECIFICATIONS FOR BIOVENTING SYSTEM DESIGN

APPENDIX A

ADDITIONAL SPECIFICATIONS FOR BIOVENTING SYSTEM DESIGN

A.1 Dewatering/Vent Well Construction

A.1.1 Drilling

Drilling work will be conducted to install approximately fifteen dual purpose dewatering and soil vapor extraction wells. A nominal 6-inch internal diameter, continuous flight hollow stem auger will be used for drilling boreholes for vapor extraction wells. The boreholes for the vapor extraction wells will be approximately 12 inches in diameter and advanced to the top of the clay layer, a depth of 15 to 24 feet.

Soil samples will be collected for lithologic description as the borings are advanced. These samples will be collected using an 18-inch long split spoon sampler following Standard Penetration Test procedures (ASTM Method D-1586) where applicable. The samples will be collected at 2-foot intervals to depths specified for each type of borehole drilled. Soils will be classified with respect to type, grain size, mineralogy (when pertinent), color, etc. The samples will also be checked for discoloration, odor, and presence of organic vapors. The presence of organic vapors will be tested by placing a portion of the sample in a bottle, sealing the bottle, then testing for the presence of organics in the headspace of the bottle using an organic vapor detector. Information gathered from these sampling efforts will be recorded on the boring log being created for that borehole.

The soil samples collected during split-spoon sampling will be screened for contamination visually and with an organic vapor detector. A portion of the sample will be tested for the presence of organic vapors by transferring the soil to a glass bottle immediately upon retrieval, filling the bottle to 3/4 full, capping the bottle with aluminum foil, waiting for approximately 5 minutes, and then inserting the probe of the organic vapor detector through the foil into the headspace. The readings obtained will be recorded on the drilling records. The samples will be examined for obvious signs of contamination including discoloration and odor. Any indications of contamination will be noted on the boring logs. The samples will be labelled and examined visually for lithologic description.

A.1.2 Well Casing

All VEWs will be constructed of new, 4-inch ID, Schedule 40, polyvinyl-chloride (PVC) casing and screen (Figure 2.4.). A threaded 4-inch PVC bottom cap will be installed at the bottom of the well. The top of the well will be fitted with a tee and

cap which will allow a 1 inch water line and air line to pass into the well for dewatering while a 2 psi vacuum is maintained in the well. Whenever possible, air tight threaded fittings will be used. All PVC casing will be straight and plumb, and will conform to ASTM Standards F-480-88A or National Sanitation Foundation Standard 14 (Plastic Pipe Section). The PVC casing will be visually inspected by the on site geologist prior to installation. Any section of PVC pipe that does not appear straight and in good condition will be rejected.

A.1.3 Well Screen

The VEWs will each have a 10 to 15 foot section of PVC screen. Screens will be 4-inch ID and constructed of Schedule 40 PVC factory-slotted screen. Screen slot size will be 0.020-inch. Screen intervals will vary with the depth to the clay layer.

A.1.4 Filter Pack

A filter pack will be emplaced in each VEW from the bottom of the borehole to one foot above the top of the well screen. The filter pack will be tremied into the annular space using a 1.5-inch (minimum) diameter pipe. The tremie pipe will be lifted from the bottom of the hole at the same rate that the filter pack is set. The filter pack material will be clean, well rounded, inert silica sand. Filter pack shall be No. 6-9 silica sand (or equivalent).

A.1.5 Bentonite Seal

A 36-inch thick wet bentonite seal will be placed directly above the filter pack in the vent wells. The bentonite will be tremied into the annular space. A minimum of one hour will be allowed for hydration of the bentonite before installation of the grout seal. The bentonite must form a complete seal. The depths at which bentonite seals will be placed in the VEWs are also shown in Figure 2.4.

A.1.6 Grout Seal/Grouting

A 6-inch grout seal will be emplaced above the bentonite seal in the vent wells. The grout will be mixed in the following proportions:

- 94 pounds of neat Type I Portland (or API Class A) cement.
- 4 pounds of pure sodium bentonite powder.
- 6.5 gallons of potable water.

Because of the shallow depth of well completion the grout can be poured.

A.1.7 Surface Completion of Vent Wells

Each of the vent wells will be completed flush to the surface using a 12 X 18-inch metal box. This large box will be required to accommodate valves for both dewatering and vacuum lines.

A.2 Piping and Air Injection Trench Excavations

The bioventing system will also require two air injection trenches and air supply piping excavations. Locations of the proposed excavations are presented on Figure 2.3. A typical section of pipe and air injection trench is included in the conceptual

details for the bioventing systems on Figure 2.5. Installation of trenches for system piping will be in accordance with OSHA regulations.

A.2.1 Air Injection Trenches

Air injection trenches will be used to recirculate hydrocarbon vapors for treatment in the soil and to circulate additional oxygen to contaminated soils.

Trenches constructed for installation of the air injection piping will be excavated to a depth of 6 feet and 2 foot in width. The actual bottom of the trench will be determined by the on-site ES engineer based on the stability of the undisturbed material. Sections of the trenches to be constructed are shown on Figure 2.5.

A.2.2. Auxiliary Piping Trenches

Trenches constructed for installation of vacuum line piping will be excavated to a maximum of 18 inches. If foundation soil is soft, wet, unstable or does not afford solid foundation for pipe, the subcontractor will excavate 6 inches below pipe grade and backfill with approved material as specified below.

A.2.3 Utilities

Prior to any excavation activities, the excavation/drilling contractor will meet with a base civil engineering representative and determine the location of all underground utilities in the proposed trenching areas. Utilities will be identified in the field and marked by the base civil engineering personnel. All appropriate digging permits will be obtained from the base before excavation activities are initiated.

A.2.4 Photographs

Photographs of the trenching operations will be taken to document test activities. Photographs will be stored in the ES project files and will be provided to AFCEE and Vandenberg AFB.

A.2.5 Piping Construction

A.2.5.1 Air Injection Piping

The purpose of the air injection pipes will be to recirculate hydrocarbon vapors and provide oxygen to the contaminated soils at the south and east end of the site. The pipe will be laid in the bottom of the trench at an approximate depth of 6 feet. All injection pipes will be constructed of 2-inch Schedule 40 PVC screen with 0.02 slot. Screen lengths will be furnished in 10-foot flush threaded lengths. The PVC piping will be inspected by the onsite ES representative prior to installation. Any section of PVC pipe that does not appear in good condition will be rejected. All elbows, joints and fittings will be connected using standard PVC cements.

Backfill between the injection screen and the trench will consist of a gravel pack made up of pea size gravel. The gravel pack will be uniform in size and will be introduced uniformly across the screened interval. The gravel pack will extend approximately 4 inches above the top of the screen. A sheet of 10-mil PVC material will be laid on top of the gravel pack and overlain by 6 inches of wet bentonite and

natural backfill to the ground surface as shown in Figure 2.5. Backfill will be compacted to 95% of its native density.

A.2.5.2 Vacuum and Injection Line Piping

Vacuum and injection line piping will be installed at the site as shown in Figure 2.3 and 2.5. All vacuum and injection line piping will be constructed of solid 2-inch Schedule 40 PVC pipe. All elbows, joints and fittings will be threaded and air tight. Vacuum lines will slope toward the vacuum wells to allow condensate to drain into the VEW and away from the blower.

Backfill material for auxiliary pipe trenches will consist of uncontaminated natural soil or equivalent material. In areas of heavy traffic, material will be placed in 6 inch layers and compacted by tamping. Backfilling of the pipe zone will be completed by hand with particular attention to the underside of pipe and pipe fittings. Backfill will be placed to provide a firm support along the full length of the pipe.

A.3 Decontamination Procedures

A.3.1 General Decontamination Procedures

All equipment and tools that will be used at the site will be cleaned as necessary prior to each use. This effort will help prevent possible sample contamination from the variety of sampling equipment, tools and machinery that will be available for use during the execution of the field work. Decontamination will be documented in the field log book.

A.3.2 Drilling Equipment

The drilling rig will be decontaminated by steam cleaning, washing with a non-phosphate laboratory-grade detergent and rinsing with potable water before moving to perform drilling work. All other drilling equipment, including casing and well screens, will be decontaminated following the procedures mentioned below.

A.3.3 Sampling Equipment

All tools used for sampling, including split spoons, will be decontaminated before each use. Decontamination will consist of a laboratory grade detergent wash (e.g., Liquinox®), potable water rinse, pesticide-grade methanol rinse, and high pressure liquid chromatography (HPLC) grade water rinse, followed by air-drying. When dry, the equipment shall be wrapped in aluminum foil until ready for use. In general, as much decontamination as possible will be done at a designated area, preferable a base wash rack. Decontamination fluids will be discharged into the base sewer system. Decontamination fluids resulting from onsite decontamination will be collected and transported to the designated area for disposal.

Decontamination will be conducted in a manner that will guard against cross-contamination of equipment. Equipment will be placed on clean plastic sheeting or on surfaces covered with aluminum foil. Personnel will wear clean vinyl gloves during decontamination of equipment.

All decontamination procedures performed during the course of the field work will be documented in the field logbook. Any deviation from these decontamination procedures will be noted.

A.4 Asphalt/Pavement Patching

This section includes the material and construction requirements necessary to repair any asphalt or pavement changed by construction of the bioventing system. Any asphalt or pavement to be removed will be saw cut along straight lines to provide a vertical surface abutting asphalt or pavement to remain.

A.4.1 Materials

The aggregate used for the base will match existing material. The aggregate will consist of clean, hard durable fragments or particles of stone crushed to conform to that of aggregate commonly used at Vandenberg AFB in an area subject to loading by semi-tractor trailers and other heavy vehicles.

The asphalt mix used to replace the excavated surface material will match the existing material. The mix will conform to mixes commonly used in the area for surfaces designed for fully loaded semi-tractor trailers.

A.4.2 Aggregate and Asphalt Placement

Prior to placement of aggregate, the surface of the subgrade will be compacted to provide a firm surface. The aggregate will be placed in layers of not more than 2 inches (compacted) in thickness to match existing conditions. Aggregate will be placed directly on the prepared subgrade or on the preceding layer of compacted aggregate by approved methods. Immediately after material has been placed, it will be compacted with a vibratory compactor.

The asphalt mix shall be placed in layers or lifts of not more than 2 inches (compacted) in thickness to match existing conditions. Asphalt shall be placed directly on the prepared base or on the preceding layer of compacted asphalt by approved methods. Immediately after material has been placed, it shall be compacted with a vibratory compactor of adequate size and then approved by the onsite ES representative prior to any additional covering. The edges of the repaired section shall meet the existing pavement in flush, vertical joints to prevent mixing of new and old asphalt.

A.5 Extraction Equipment

The vapor extraction (VE) unit to be used for the bioventing test is depicted in a flow diagram included in the site conceptual details provided on Figure 2.3. The unit consists of a vacuum blower, starter, air filter, flow control and air bleed valves, pressure and temperature gauges, flow indicator, and air sampling points. The following section describes the equipment and processes.

Based on a similar bioventing system at Eglin AFB, a continuous extraction rate of 8-10 scfm per well should produce a single well radius of oxygen influence of approximately 40 ft beneath the asphalt surface. Radius of influence, minimum oxygen supply requirements, and the area of contaminated soil were used for the total system design.

A.5.1 Vacuum Blower

To create a vacuum in the subsurface, a vacuum blower will be used to remove air from the VEWs. A blower capable of providing 40 scfm at approximately 40 inches of water-column vacuum is required. A Gast Model R5110N or EG&G Rotron Model DR505 AR72M or equivalent has been selected as the vacuum blower to be used on site. The blower will be constructed of aluminum for explosion proof operation.

The blower is driven by an explosion-proof 2.5-horsepower electric motor. It is rated for continuous-duty service, full-voltage starting, and is suitable for outdoor locations. A 230-volt, three-phase, 150 amp, 60-cycle electrical power source will be required at the site. This source will require three breakers, one 100 amp/230-volt for the PADRE® unit, one 30 amp/230-volt for the blower one 20 amp/110-volt circuit for smaller equipment. A blower starter will be installed by ES.

A.5.2 Instrumentation

Piping connecting each vacuum well to the blower will consist of 2-inch-inside-diameter, Schedule-40 PVC pipe and fittings. As mentioned before, a 2-inch PVC header will be used to manifold the air flow from each VEW. A vacuum indicator and a temperature indicator will be located in 1.5-inch-diameter galvanized inlet pipe (V1 and T1 shown on Figure 2.5). A dilution valve will also be installed in the 1.5-inch galvanized pipe to regulate the vacuum and flow rate.

The vacuum lines are designed to be self-draining toward the wells. A water knock-out pot may be required if significant moisture condenses in the air filter unit. A knock-out pot will not be placed on the unit initially because it requires frequent maintenance. However, the blower configuration will allow the installation of a knock-out if required.

A particulate filter will be placed in-line between the PADRE® unit and the blower to protect the blower. A vacuum indicator will be installed after the filter to measure the pressure differential across the filter (V2 shown on Figure 2.5). A vacuum relief valve will also be provided between the filter and blower. If the filter becomes fouled, the vacuum relief valve will prevent damage to the piping and blower. A pressure indicator (0-100 inches H₂O) and temperature indicators will be installed between the blower outlet and the discharge piping (P3 and T2 shown on Figure 2.5). The discharge piping will consist of steel and PVC piping.

Vapor-sampling points will be placed at several locations to collect gas samples (S shown on Figure 2.5).

A.6 Vapor Treatment Unit

Details on the PADRE® vapor treatment unit are found in Appendix B.

APPENDIX B
DETAILS ON PADRE VAPOR® TREATMENT UNIT

PURUS®

Vandenberg Air Force Base Application Gasoline Vapor Treatment

THE PADRE™ SYSTEM

The PADRE™ system is a new vapor treatment process now being offered by Purus, Inc.. PADRE™ is a proprietary regenerative adsorption method applicable for volatile organic compounds (VOC). This process has demonstrated the ability to recycle the adsorption bed in excess of 2,000 times with no appreciable loss of adsorption capacity. Plus, the adsorption beds have a high tolerance to water vapor, allowing processing of air streams with relative humidities greater than 90% with little impact on adsorption efficiencies. These two capabilities now make it possible to have an economic on-site recycling treatment system for substantially lower operating and capital costs than was available previously. Purus systems are permitted in many air districts in the United States, including California's Bay Area and South Coast districts.

SYSTEM DESCRIPTION

PADRE™ treatment systems are designed to control VOC emissions at site remediation projects, industrial waste water facilities, and industrial air processes. Site remediation usually involves vacuum extraction of solvents or fuels from soils, in many cases with the need for pumping and treatment of ground water. Purus provides treatment units for soil vacuum extraction and ground water air stripping in which VOCs vapors are treated with the PADRE™ regenerative adsorption system. PADRE™ units can also treat industrial waste waters containing solvents using an emission free closed-loop air stripping process. Call Purus for more information regarding your specific application.

The PADRE™ system purifies contaminated air streams directly from a soil vapor extraction well or a water air stripper by trapping the contaminant onto a proprietary adsorbent filter bed (See Figure 1). The process involves one bed, or a series of beds, on-line treating influent air, while another bed is undergoing a desorption cycle. The beds are automatically switched back and forth between adsorption and desorption cycles with an on-board control system. The desorption cycle utilizes a combination of temperature, pressure, and a carrier gas. During the desorption cycle, all the organic contaminants trapped in the adsorbent material are removed, condensed, and transferred as a liquid to a storage tank. The recovered compounds are easily reclaimed and disposed on a periodic basis by solvent recyclers or fuel blenders in your area. The system is self contained and skid mounted.

PADRE™ Model 1.6 SPECIFICATIONS

Medium:	Adsorbents tailored to site requirements.
Applications:	Air flow from soil vacuum extraction, air stripping, and industrial air processes.
Contaminants:	Fuel hydrocarbons, chlorinated solvents, ketones, other VOCs.
VOC Reduction:	Typically greater than 99%.
Recovery:	Contaminant is recovered as liquid and transferred to a storage tank. Some water will be present depending on relative humidity.
Safety:	System has safety controls and interlocks for safe operation. System meets NEC and NFPA codes. For outdoor operation, controls built into NEMA 4 enclosure.
Control System:	PLC, and modem.
Optional Equipment:	Fully integrated systems including vacuum pump, air stripper, water knock-out tank, and recovery storage tank are available upon request.
Capacity:	Up to 150 cfm
Footprint:	8'W x 12'L x 6'H
Weight:	8,000 pounds
Power:	220V±10%, 3-phase, 100 amp (max)
Note:	Exact system specifications subject to site requirements.

Figure 1. PADRE™ Schematic

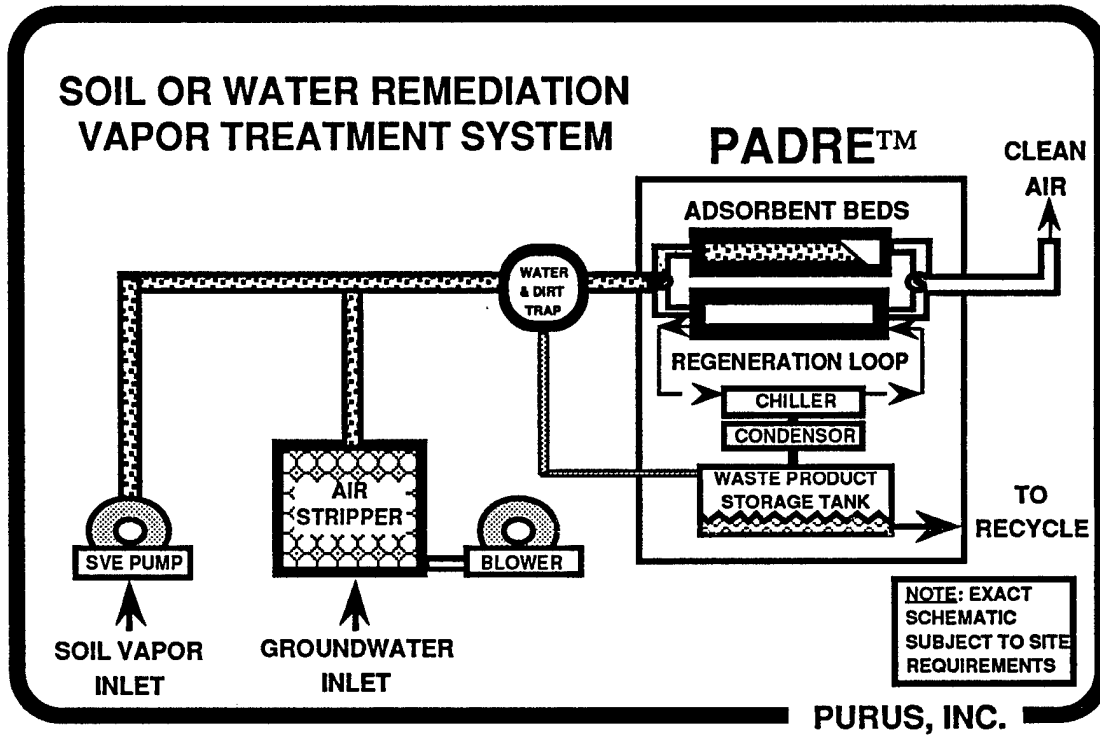
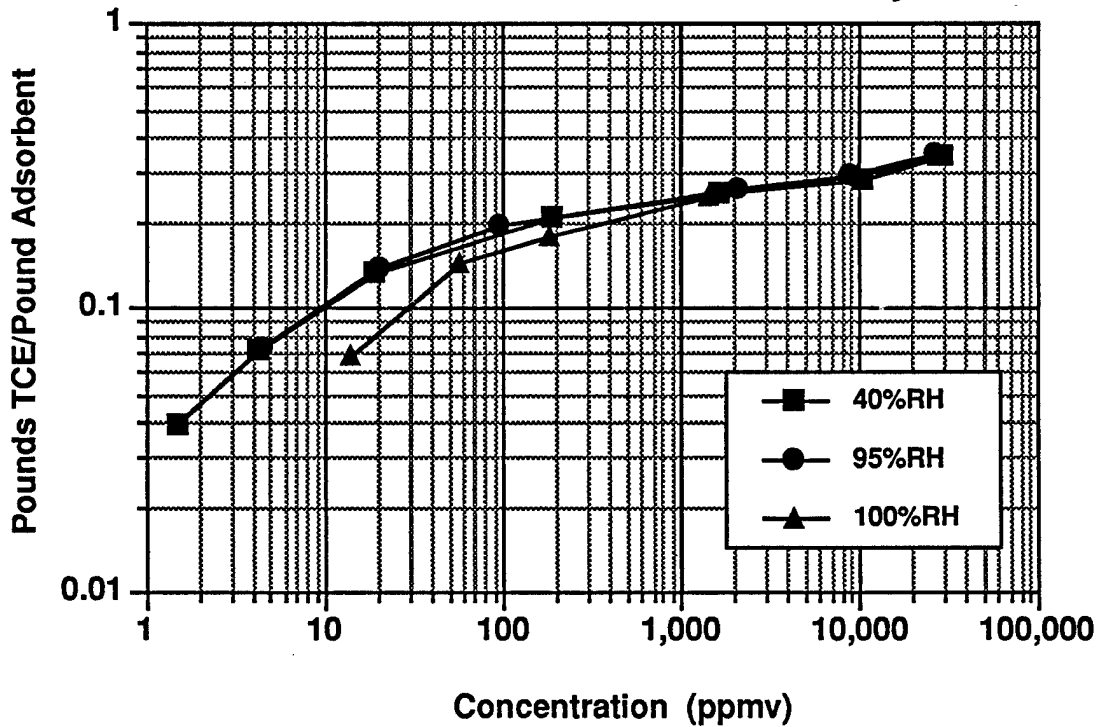
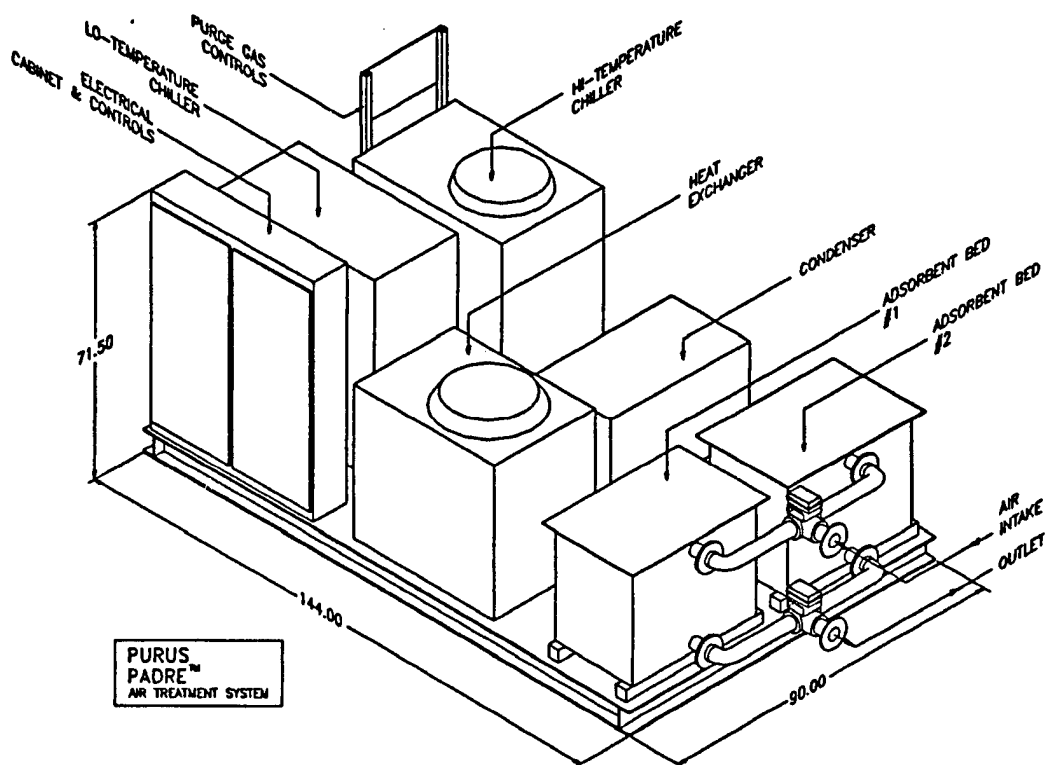

Figure 2.

**PADRE™ Adsorbent
TCE Isotherm vs. Relative Humidity**



PADRE TREATMENT SYSTEM MODEL 1.6 DIMENSIONAL DRAWING



Vandenberg Gasoline Application

According to soil gas analyses conducted at the BX station at Vandenberg, gasoline vapors in the high ppmv levels are anticipated at start up. In the Purus laboratory, gasoline vapors were passed through a small scale adsorbent bed (0.125 pounds adsorbent) to determine the working capacity of the adsorbent to be used on the full scale unit. The gasoline concentration was introduced at 6,000 ppmv total TPH, with benzene accounting for slightly less than 1% of the gasoline mix. The bed was loaded at a rate of 0.035 pounds per hour. After 45 minutes, the TPH breakthrough concentration was less than 5% of the input concentration. The benzene breakthrough concentration was non-detect. Using 45 minutes as the treatment time, the working isotherm for the adsorbent is 21% (0.026 pounds gasoline in 45 minutes / 0.125 pounds adsorbent).

Using this as a model for Vandenberg, a working capacity for the full scale PADRE™ unit can be predicted. The PADRE™ model 1.6 bed contains 126 pounds of Purus Adsorbent. Assuming a 21% isotherm, the bed will be able to treat 26 pounds of gasoline. The minimum cycle time for desorbing the bed is 2.25 hours, giving a total adsorb/desorb cycle time of 3 hours. Thus, the PADRE™ unit should be able to treat approximately 8.8 pounds of gasoline per hour. Actual site conditions may vary, depending on the actual concentration of the various gasoline components. However, the bench scale test predicts that the unit should easily treat the 5 cfm flow rate proposed by Engineering Science at start-up, with the effluent staying below the 1000 ppmv limit for reinjection into the soil trenches.

Figure 1

PurCycle™

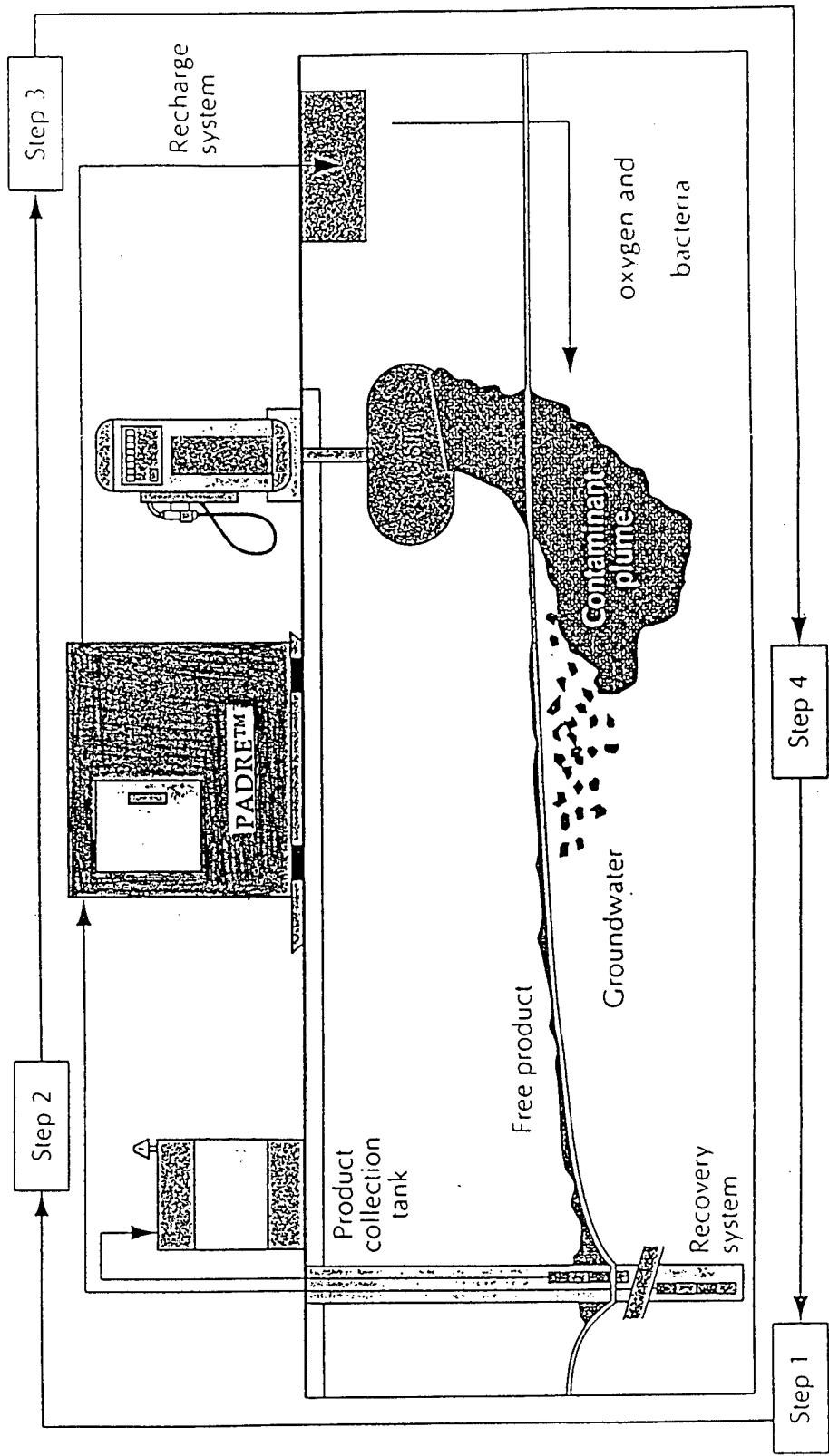

Adsorption Isotherms for Aromatic Compounds on PurSorb™ 200 30°C, 100% RH

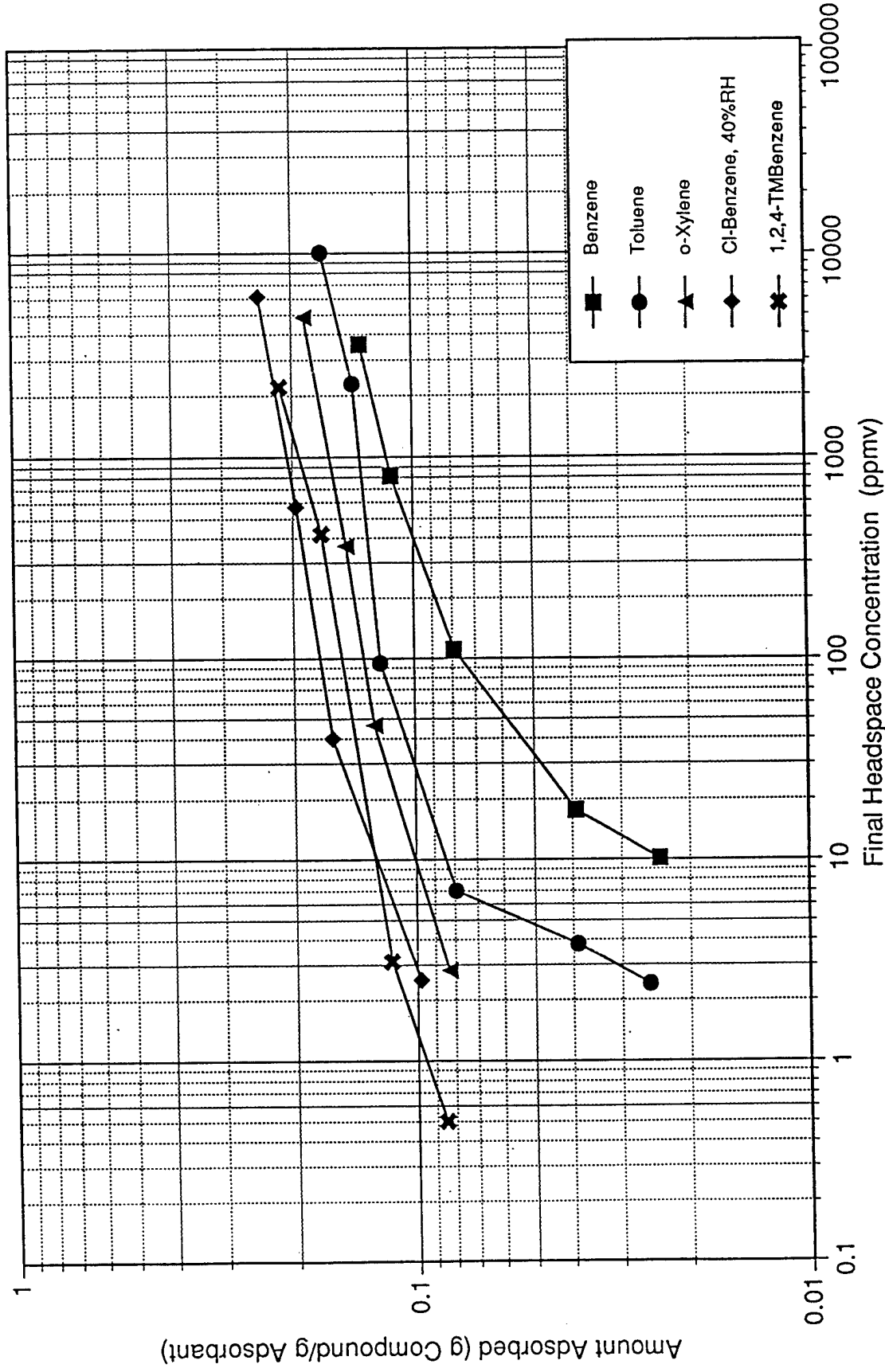

Adsorption Isotherms for Alkanes and Ethers on PurSorb™ 200
30°C, 100% RH

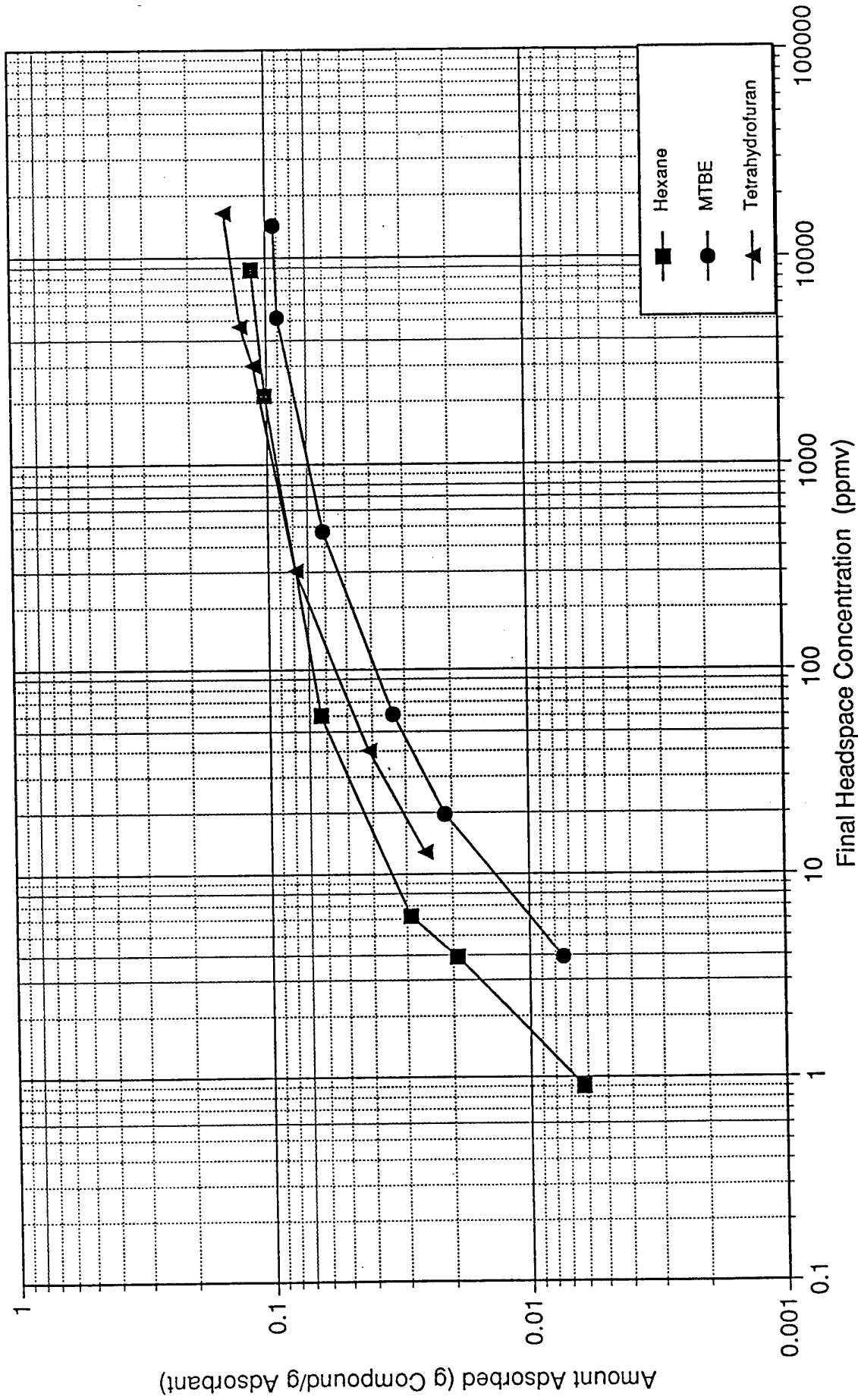

Adsorption Isotherms for Chlorinated Olefins on PurSorb™ 200
30°C, 100% RH

